

NuMicro[®] Family M480 Series Datasheet

The information described in this document is the exclusive intellectual property of Nuvoton Technology Corporation and shall not be reproduced without permission from Nuvoton.

Nuvoton is providing this document only for reference purposes of NuMicro microcontroller based system design. Nuvoton assumes no responsibility for errors or omissions.

All data and specifications are subject to change without notice.

For additional information or questions, please contact: Nuvoton Technology Corporation.

www.nuvoton.com

TABLE OF CONTENTS

1 GENERAL DESCRIPTION..... 11

2 FEATURES 12

 2.1 NuMicro[®] M480 Features..... 12

3 PARTS INFORMATION 24

 3.1 Summary 24

 3.2 Package Type 24

 3.3 NuMicro[®] M481 Base Series 25

 3.4 NuMicro[®] M482 USB FS OTG Series..... 26

 3.5 NuMicro[®] M483 CAN Series 27

 3.6 NuMicro[®] M484 USB HS OTG Series 28

 3.7 NuMicro[®] M485 Crypto Series 29

 3.8 NuMicro[®] M487 Ethernet Series 30

 3.9 NuMicro[®] M480 Naming Rule 31

4 PIN CONFIGURATION & DESCRIPTION 32

 4.1 Pin Configuration..... 32

 4.1.1 NuMicro[®] M481 Base Series QFN33 Pin Diagram 32

 4.1.2 NuMicro[®] M481 Base Series LQFP48 Pin Diagram 33

 4.1.3 NuMicro[®] M481 Base Series LQFP64 Pin Diagram 34

 4.1.4 NuMicro[®] M482 USB FS OTG Series QFN33 Pin Diagram 35

 4.1.5 NuMicro[®] M482 USB FS OTG Series LQFP48 Pin Diagram..... 36

 4.1.6 NuMicro[®] M482 USB FS OTG Series LQFP64 Pin Diagram..... 37

 4.1.7 NuMicro[®] M482 USB FS OTG Series LQFP128 Pin Diagram..... 38

 4.1.8 NuMicro[®] M483 CAN Series LQFP64 Pin Diagram 39

 4.1.9 NuMicro[®] M483 CAN Series LQFP128 Pin Diagram..... 40

 4.1.10 NuMicro[®] M484 USB HS OTG Series LQFP64 Pin Diagram 41

 4.1.11 NuMicro[®] M484 USB HS OTG Series with 2 USB LQFP64 Pin Diagram..... 42

 4.1.12 NuMicro[®] M484 USB HS OTG Series LQFP128 Pin Diagram 43

 4.1.13 NuMicro[®] M485 Crypto Series QFN33 Pin Diagram..... 44

 4.1.14 NuMicro[®] M485 Crypto Series LQFP48 Pin Diagram..... 45

 4.1.15 NuMicro[®] M485 Crypto Series LQFP64 Pin Diagram..... 46

 4.1.16 NuMicro[®] M485 Crypto Series LQFP128 Pin Diagram..... 47

 4.1.17 NuMicro[®] M487 Ethernet Series LQFP64 Pin Diagram..... 48

 4.1.18 NuMicro[®] M487 Ethernet Series LQFP128 Pin Diagram..... 49

 4.1.19 NuMicro[®] M487 Ethernet Series LQFP144 Pin Diagram..... 50

 4.2 Pin Description 51

 4.2.1 M481 Series Pin Description 51

 4.2.2 M482 Series Pin Description 68

 4.2.3 M483 Series Pin Description 97

 4.2.4 M484 Series Pin Description 125

 4.2.5 M485 Series Pin Description 152

 4.2.6 M487 Series Pin Description 180

 4.2.7 M480 Multi-function Summary Table 211

4.2.8 M480 Multi-function Summary Table Sorted by GPIO 238

5 BLOCK DIAGRAM..... 269

5.1 NuMicro[®] M480 Block Diagram 269

6 FUNCTIONAL DESCRIPTION..... 270

6.1 ARM[®] Cortex[®]-M4 Core 270

6.2 System Manager 273

6.2.1 Overview 273

6.2.2 System Reset 273

6.2.3 System Power Distribution 279

6.2.4 Power Modes and Wake-up Sources 280

6.2.5 Power Modes Transition 284

6.2.6 System Memory Map 285

6.2.7 SRAM Memory Organization 287

6.2.8 Bus Matrix 289

6.2.9 HIRC Auto Trim 289

6.2.10 System Timer (SysTick) 290

6.2.11 Nested Vectored Interrupt Controller (NVIC) 290

6.3 Clock Controller 291

6.3.1 Overview 291

6.3.2 Clock Generator 293

6.3.3 System Clock and SysTick Clock 294

6.3.4 Peripherals Clock 295

6.3.5 Power-down Mode Clock 296

6.3.6 Clock Output 296

6.3.7 USB Clock Source 297

6.4 Flash Memory Controller (FMC) 298

6.4.1 Overview 298

6.4.2 Features 298

6.5 General Purpose I/O (GPIO) 299

6.5.1 Overview 299

6.5.2 Features 299

6.6 PDMA Controller (PDMA) 300

6.6.1 Overview 300

6.6.2 Features 300

6.7 Timer Controller (TMR) 301

6.7.1 Overview 301

6.7.2 Features 301

6.8 Watchdog Timer (WDT) 303

6.8.1 Overview 303

6.8.2 Features 303

6.9 Window Watchdog Timer (WWDT) 304

6.9.1 Overview 304

6.9.2 Features 304

6.10 Real Time Clock (RTC) 305

6.10.1 Overview 305

6.10.2	Features	305
6.11	EPWM Generator and Capture Timer (EPWM).....	306
6.11.1	Overview	306
6.11.2	Features	306
6.12	Basic PWM Generator and Capture Timer (BPWM)	308
6.12.1	Overview	308
6.12.2	Features	308
6.13	Quadrature Encoder Interface (QEI)	309
6.13.1	Overview	309
6.13.2	Features	309
6.14	Enhanced Input Capture Timer (ECAP)	310
6.14.1	Overview	310
6.14.2	Features	310
6.15	UART Interface Controller (UART)	311
6.15.1	Overview	311
6.15.2	Features	311
6.16	Ethernet MAC Controller (EMAC).....	313
6.16.1	Overview	313
6.16.2	Features	313
6.17	Smart Card Host Interface (SC).....	314
6.17.1	Overview	314
6.17.2	Features	314
6.18	I ² S Controller (I ² S).....	315
6.18.1	Overview	315
6.18.2	Features	315
6.19	Serial Peripheral Interface (SPI)	316
6.19.1	Overview	316
6.19.2	Features	316
6.20	Quad Serial Peripheral Interface (QSPI)	318
6.20.1	Overview	318
6.20.2	Features	318
6.21	SPI Synchronous Serial Interface Controller (SPI Master mode).....	319
6.21.1	Overview	319
6.21.2	Features	319
6.22	I ² C Serial Interface Controller (I ² C).....	320
6.22.1	Overview	320
6.22.2	Features	320
6.23	USCI - Universal Serial Control Interface Controller (USCI)	321
6.23.1	Overview	321
6.23.2	Features	321
6.24	USCI – UART Mode	322
6.24.1	Overview	322
6.24.2	Features	322
6.25	USCI - SPI Mode	323

6.25.1	Overview	323
6.25.2	Features	323
6.26	USCI - I ² C Mode	325
6.26.1	Overview	325
6.26.2	Features	325
6.27	Controller Area Network (CAN)	326
6.27.1	Overview	326
6.27.2	Features	326
6.28	Secure Digital Host Controller (SDH)	327
6.28.1	Overview	327
6.28.2	Features	327
6.29	External Bus Interface (EBI)	328
6.29.1	Overview	328
6.29.2	Features	328
6.30	USB 1.1 Device Controller (USBD)	329
6.30.1	Overview	329
6.30.2	Features	329
6.31	High Speed USB 2.0 Device Controller (HSUSBD)	330
6.31.1	Overview	330
6.31.2	Features	330
6.32	USB 2.0 Host Controller (USBH)	331
6.32.1	Overview	331
6.32.2	Features	331
6.33	USB On-The-Go (OTG)	332
6.33.1	Overview	332
6.33.2	Features	332
6.34	High Speed USB On-The-Go (HSOTG)	333
6.34.1	Overview	333
6.34.2	Features	333
6.34.3	Basic Configuration	333
6.35	CRC Controller (CRC)	334
6.35.1	Overview	334
6.35.2	Features	334
6.36	Cryptographic Accelerator (CRYPTO)	335
6.36.1	Overview	335
6.36.2	Features	335
6.37	Enhanced 12-bit Analog-to-Digital Converter (EADC)	337
6.37.1	Overview	337
6.37.2	Features	337
6.38	Digital to Analog Converter (DAC)	339
6.38.1	Overview	339
6.38.2	Features	339
6.39	Analog Comparator Controller (ACMP)	340
6.39.1	Overview	340

6.39.2 Features 340

6.40 OP Amplifier (OPA)..... 341

6.40.1 Overview 341

6.40.2 Features 341

7 APPLICATION CIRCUIT 342

7.1 Power Supply Scheme with External Vref 342

7.2 Power Supply Scheme with Internal Vref..... 343

7.3 Power Supply Scheme with V_{REF} and External RTC with Battery Power 344

7.4 Power Supply Scheme with V_{REF} and Internal RTC with Battery Power 345

7.5 Peripheral Application Scheme 346

8 ELECTRICAL CHARACTERISTICS..... 348

8.1 Absolute Maximum Ratings 348

8.1.1 Voltage Characteristics..... 348

8.1.2 Current Characteristics..... 348

8.1.3 Thermal Characteristics..... 348

8.1.4 EMC Characteristics 349

8.2 General Operating Conditions 350

8.3 DC Electrical Characteristics 351

8.3.1 Typical Current Consumption 351

8.3.2 On-chip Peripheral Current Consumption..... 358

8.3.3 Wakeup Time 359

8.3.4 PIN DC Characteristics..... 360

8.4 AC Electrical Characteristics..... 362

8.4.1 External 4~24 MHz High Speed Crystal (HXT) characteristics 362

8.4.2 External 4~24 MHz High Speed Clock Input (OSC) Characteristics..... 363

8.4.3 External 32.768 kHz Low Speed Crystal (LXT) characteristics 364

8.4.4 External 32.768 kHz Low Speed Clock Input (OSC) Characteristics..... 365

8.4.5 12 MHz Internal High Speed RC Oscillator (HIRC) 365

8.4.6 10 kHz Internal Low Speed RC Oscillator (LIRC)..... 366

8.4.7 PLL Characteristics 366

8.4.8 PIN AC Characteristics..... 366

8.5 Analog Electrical Characteristics 368

8.5.1 LDO 368

8.5.2 Low-Voltage Reset 368

8.5.3 Brown-out Detector..... 368

8.5.4 Power-on Reset..... 369

8.5.5 Internal Voltage Reference..... 369

8.5.6 12-bit ADC..... 370

8.5.7 Temperature Sensor..... 373

8.5.8 Digital to Analog Converter (DAC)..... 373

8.5.9 Analog Comparator Controller (ACMP) 375

8.5.10 OP Amplifier (OPA) 375

8.6 Flash DC Electrical Characteristic 377

8.7 I²C Dynamic Characteristics 378

8.8	SPI Dynamic Characteristics	379
8.9	I ² S Dynamic Characteristics.....	382
8.10	USCI - I ² C Dynamic Characteristics	384
8.11	USCI - SPI Dynamic Characteristics	385
8.12	USB Characteristics.....	388
8.12.1	USB Full-Speed.....	388
8.12.2	USB Full-Speed PHY characteristics.....	388
8.12.3	USB High-Speed characteristics	388
8.13	Ethernet Characteristics	389
8.13.1	RMII Interface Timing	389
8.13.2	Ethernet PHY Management Interface Timing	389
8.14	SDIO Characteristics	391
8.14.1	Default Mode Timing	391
8.14.2	SDIO Dynamic characteristics.....	391
9	PACKAGE OUTLINE DRAWING	393
9.1	QFN 33L (5x5x0.8 mm ³ Pitch 0.5 mm)	393
9.2	LQFP 48L (7x7x1.4 mm ³ Footprint 2.0mm)	394
9.3	LQFP 64L (7x7x1.4 mm ³ footprint 2.0 mm)	395
9.4	LQFP 128L (14x14x1.4 mm ³ footprint 2.0 mm)	396
9.5	LQFP 144L (20x20x1.4 mm ³ footprint 2.0 mm)	397
10	ABBREVIATION	398
10.1	Abbreviations	398
11	REVISION HISTORY	400

LIST OF FIGURES

Figure 4.1-1 NuMicro® M481 Base Series QFN 33-pin Diagram..... 32

Figure 4.1-2 NuMicro® M481 Base Series LQFP 48-pin Diagram..... 33

Figure 4.1-3 NuMicro® M481 Base Series LQFP 64-pin Diagram..... 34

Figure 4.1-4 NuMicro® M482 USB FS OTG Series QFN 33-pin Diagram 35

Figure 4.1-5 NuMicro® M482 USB FS OTG Series LQFP 48-pin Diagram 36

Figure 4.1-6 NuMicro® M482 USB FS OTG Series LQFP 64-pin Diagram 37

Figure 4.1-7 NuMicro® M482 USB FS OTG Series LQFP 128-pin Diagram 38

Figure 4.1-8 NuMicro® M483 CAN Series LQFP 64-pin Diagram 39

Figure 4.1-9 NuMicro® M483 CAN Series LQFP 128-pin Diagram 40

Figure 4.1-10 NuMicro® M484 USB HS OTG Series LQFP 64-pin Diagram..... 41

Figure 4.1-11 NuMicro® M484 USB HS OTG Series with 2 USB LQFP 64-pin Diagram..... 42

Figure 4.1-12 NuMicro® M484 USB HS OTG Series LQFP 128-pin Diagram..... 43

Figure 4.1-13 NuMicro® M485 Crypto Series QFN 33-pin Diagram 44

Figure 4.1-14 NuMicro® M485 Crypto Series LQFP 48-pin Diagram 45

Figure 4.1-15 NuMicro® M485 Crypto Series LQFP 64-pin Diagram 46

Figure 4.1-16 NuMicro® M485 Crypto Series LQFP 128-pin Diagram 47

Figure 4.1-17 NuMicro® M487 Ethernet Series LQFP 64-pin Diagram 48

Figure 4.1-18 NuMicro® M487 Ethernet Series LQFP 128-pin Diagram 49

Figure 4.1-19 NuMicro® M487 Ethernet Series LQFP 144-pin Diagram 50

Figure 5.1-1 NuMicro® M480 Block Diagram 269

Figure 6.1-1 Cortex®-M4 Block Diagram..... 270

Figure 6.2-1 System Reset Sources 274

Figure 6.2-2 nRESET Reset Waveform 276

Figure 6.2-3 Power-on Reset (POR) Waveform 276

Figure 6.2-4 Low Voltage Reset (LVR) Waveform..... 277

Figure 6.2-5 Brown-out Detector (BOD) Waveform 278

Figure 6.2-6 NuMicro® M480 Power Distribution Diagram..... 279

Figure 6.2-7 Power Mode State Machine 281

Figure 6.2-8 NuMicro® M480 Power Distribution Diagram..... 284

Figure 6.2-9 SRAM Block Diagram 287

Figure 6.2-10 SRAM Memory Organization 288

Figure 6.2-11 NuMicro® M480 Bus Matrix Diagram..... 289

Figure 6.3-1 Clock Generator Global View Diagram..... 292

Figure 6.3-2 Clock Generator Block Diagram 293

Figure 6.3-3 System Clock Block Diagrams 294

Figure 6.3-4 HXT Stop Protect Procedure 295

Figure 6.3-5 SysTick Clock Control Block Diagram 295

Figure 6.3-6 Clock Output Block Diagram 296

Figure 6.3-7 USB Clock Source 297

Figure 6.25-1 SPI Master Mode Application Block Diagram..... 323

Figure 6.25-2 SPI Slave Mode Application Block Diagram..... 323

Figure 6.26-1 I²C Bus Timing..... 325

Figure 8.3-1 Current Consumption versus Temperature in Normal Run Mode, V_{DD} = 3.3V , All Peripherals Disabled, PLL Source from HIRC..... 352

Figure 8.3-2 Current Consumption versus Temperature in Normal Run Mode, V_{DD} = 3.3V , All Peripherals Enabled, PLL Source from HIRC..... 352

Figure 8.3-3 Current Consumption versus temperature in Normal Run Mode, V_{DD} = 3.3V , All Peripherals Disabled, PLL Source from HXT 353

Figure 8.3-4 Current Consumption versus Temperature in Normal Run Mode, V_{DD} = 3.3V , All Peripherals Enabled, PLL Source from HXT 353

Figure 8.3-5 Current Consumption versus Temperature in Idle Mode, V_{DD} = 3.3V , All Peripherals Disabled, PLL Source from HIRC 355

Figure 8.3-6 Current Consumption versus Temperature in Idle Mode, V_{DD} = 3.3V , All Peripherals Enabled, PLL Source from HIRC 355

Figure 8.3-7 Current Consumption versus Temperature in Idle Mode, V_{DD} = 3.3V , All Peripherals Disabled, PLL Source from HXT 356

Figure 8.3-8 Current Consumption versus Temperature in Idle Mode, V_{DD} = 3.3V , All Peripherals Enabled, PLL Source from HXT..... 356

Figure 8.4-1 Typical Crystal Application Circuit 363

Figure 8.4-2 Typical Crystal Application Circuit 365

Figure 8.5-1 Power-up Ramp Condition 369

Figure 8.5-2 Typical Connection with Internal Voltage Reference..... 370

Figure 8.7-1 I²C Timing Diagram 378

Figure 8.8-1 SPI Master Mode Timing Diagram 379

Figure 8.8-2 SPI Slave Mode Timing Diagram 381

Figure 8.9-1 I²S Master Mode Timing Diagram..... 382

Figure 8.9-2 I²S Slave Mode Timing Diagram..... 383

Figure 8.10-1 I²C Timing Diagram 384

Figure 8.11-1 SPI Master Mode Timing Diagram 385

Figure 8.11-2 SPI Slave Mode Timing Diagram 387

Figure 8.13-1 RMII Interface Timing Diagram..... 389

Figure 8.13-2 Ethernet PHY Management Interface Timing Diagram 390

Figure 8.14-1 SDIO Default Mode..... 391

Figure 8.14-2 SDIO High-speed Mode 392

List of Tables

Table 6.2-1 Reset Value of Registers 275

Table 6.2-2 Power Mode Table 280

Table 6.2-3 Power Mode Difference Table 281

Table 6.2-4 Power Mode Definition Table 281

Table 6.2-5 Clocks in Power Modes 282

Table 6.2-6 Re-Entering Power-down Mode Condition 284

Table 6.2-7 Address Space Assignments for On-Chip Controllers 287

Table 6.15-1 NuMicro[®] M480 Series UART Features 312

Table 8.1-1 Voltage Characteristics 348

Table 8.1-2 Current Characteristics 348

Table 8.1-3 Thermal Characteristics 349

Table 8.1-4 EMS Characteristics 349

Table 8.1-5 Electrical Characteristics 349

Table 8.3-1 Current Consumption in Normal Run Mode 351

Table 8.3-2 Current Consumption in Idle Mode 354

Table 8.3-3 Chip Current Consumption in Power-down Mode 358

Table 8.3-4 Low-power Mode Wakeup Timings 360

Table 8.3-5 PIN Input Characteristics 360

Table 8.3-6 PIN Output Characteristics 361

Table 8.3-7 nRESET PIN Characteristics 361

Table 8.4-1 External 4~24 MHz High Speed Crystal (HXT) Oscillator 363

Table 8.4-2 External 32.768 kHz Crystal 364

Table 8.4-3 I/O AC Characteristics 367

Table 10.1-1 List of Abbreviations 399

1 GENERAL DESCRIPTION

The NuMicro[®] M480 series 32-bit microcontroller powered by Arm[®] Cortex[®]-M4F with DSP extension runs up to 192 MHz with 175 μ A/MHz power consumption. Its 256/512 KB embedded Flash memory in dual-bank architecture supports Over-The-Air firmware upgrade. The 96/160 KB embedded SRAM includes 32 KB cache for speeding up code execution from the external SPI Flash. Built-in 4 KB Secure Protection ROM provides a safe space for saving confidential program or data. System supports a wide voltage range from 1.8V to 3.6V in industrial operating temperature from -40°C to 105°C.

The M480 series is equipped with a large number of high speed digital peripherals, such as a USB 2.0 high speed interface with on-chip transceiver working in device/host/OTG mode, a USB 2.0 full speed interface with on-chip transceiver working in device/host/OTG mode, up to nine UART interfaces including three ISO-7816-3 interfaces, up to four composite SPI/I²S interfaces, a Quad-SPI interface, a SPI Flash interface supporting quad mode, three I²C interfaces, a 192 kHz/32-bit I²S interface, two SDIO interfaces, two CAN 2.0B interfaces, two QEI interfaces, a 10/100 Mbps Ethernet MAC supporting RMI and two Universal Serial Control Interfaces which can be configured as UART, SPI or I²C. The M480 series also supports 16 channels peripheral DMA and up to 32 channels PWM running up to 192 MHz.

The M480 series provides high performance analog peripherals, such as a 12-bit 5MSPS SAR ADC with up to 16 channels, two 12-bit 1MSPS DAC, two analog comparators and three operational amplifiers, as well as a built-in hardware cryptography accelerator that supports ECC, AES, DES, triple DES, SHA, HMAC and a random number generator (RNG).

The NuMicro[®] M480 series includes the following sub-series:

- NuMicro[®] M481 Base series: Delivers high performance computing power with low power consumption for running complex algorithm.
- NuMicro[®] M482 USB FS OTG series: Built-in USB 2.0 full speed interface with on-chip OTG transceiver working in device/host/OTG mode.
- NuMicro[®] M483 CAN series: Built-in two sets of CAN 2.0B bus interfaces.
- NuMicro[®] M484 USB HS OTG series: Built-in USB 2.0 high speed interface with on-chip OTG transceiver working in device/host/OTG mode.
- NuMicro[®] M485 Crypto series: Built-in hardware cryptography engine and random number generator.
- NuMicro[®] M487 Ethernet series: Built-in 10/100Mbps Ethernet MAC supports industrial RMI, MDC and MDIO for communicating with an external transceiver.

2 FEATURES

2.1 NuMicro[®] M480 Features

Core and System

- | | |
|--|--|
| ARM[®] Cortex[®]-M4 | <ul style="list-style-type: none"> • ARM[®] Cortex[®]-M4 processor, running up to 192 MHz • Built-in Memory Protection Unit (MPU) • Built-in Nested Vectored Interrupt Controller (NVIC) • Hardware IEEE 754 compliant Floating-point Unit (FPU) • DSP extension with hardware divider and single-cycle 32-bit hardware multiplier • 24-bit system tick timer • Programmable and maskable interrupt • Low Power Sleep mode by WFI and WFE instructions |
|--|--|

- | | |
|---------------------------------|--|
| Brown-out Detector (BOD) | <ul style="list-style-type: none"> • Eight-level BOD with brown-out interrupt and reset option. (3.0V/2.8V/2.6V/2.4V/2.2V/2.0V/1.8V/1.6V) |
|---------------------------------|--|

- | | |
|--------------------------------|--|
| Low Voltage Reset (LVR) | <ul style="list-style-type: none"> • LVR with 1.5V threshold voltage level. |
|--------------------------------|--|

- | | |
|-----------------|---|
| Security | <ul style="list-style-type: none"> • 96-bit Unique ID (UID). • 128-bit Unique Customer ID (UCID). • One built-in temperature sensor with 1°C resolution. |
|-----------------|---|

Memories

- | | |
|--------------|---|
| Flash | <ul style="list-style-type: none"> • Dual bank 512/256 KB on-chip Application ROM (APROM) for Over-The-Air (OTA) upgrade • 192 MHz maximum frequency, with performance at zero wait cycle in continuous address read access • 4 KB on-chip Flash for user-defined loader (LDROM) • 8 KB non-readable Key Protection ROM (KPROM) for firmware programming protection • 4 KB non-readable Security Protection ROM (SPROM) for intellectual property protection • 2 KB One Time Programmable (OTP) ROM for data security • All on-chip Flash support 4 KB page erase • Fast Flash programming verification with CRC • On-chip Flash programming with In-Chip Programming (ICP), In-System Programming (ISP) and In-Application Programming (IAP) capabilities • Configurable boot up sources including boot loader, user-defined loader (LDROM) or Application ROM (APROM) • Data Flash with configurable memory size • 2-wired ICP Flash updating through SWD interface |
|--------------|---|

	<ul style="list-style-type: none"> • 32-bit/64-bit and multi-word Flash programming function
SRAM	<ul style="list-style-type: none"> • Up to 160 KB on-chip SRAM includes: <ul style="list-style-type: none"> – 32 KB SRAM located in bank 0 that supports hardware parity check and retention mode; Exception (NMI) generated upon a parity check error – 96/32 KB SRAM located in bank 1 – 32 KB SRAM located in bank 2 that can be used as cache for external SPI Flash memory • Byte-, half-word- and word-access • PDMA operation
Cyclic Redundancy Calculation (CRC)	<ul style="list-style-type: none"> • Supports CRC-CCITT, CRC-8, CRC-16 and CRC-32 polynomials • Programmable initial value and seed value • Programmable order reverse setting and one's complement setting for input data and CRC checksum • 8-bit, 16-bit, and 32-bit data width • 8-bit write mode with 1-AHB clock cycle operation • 16-bit write mode with 2-AHB clock cycle operation • 32-bit write mode with 4-AHB clock cycle operation • Uses DMA to write data with performing CRC operation
Peripheral DMA (PDMA)	<ul style="list-style-type: none"> • Sixteen independent and configurable channels for automatic data transfer between memories and peripherals • Basic and Scatter-Gather transfer modes • Each channel supports circular buffer management using Scatter-Gather Transfer mode • Stride function for rectangle image data movement • Fixed-priority and Round-robin priorities modes • Single and burst transfer types • Byte-, half-word- and word transfer unit with count up to 65536 • Incremental or fixed source and destination address
Clocks	
External Clock Source	<ul style="list-style-type: none"> • 4~24 MHz High-speed eXternal crystal oscillator (HXT) for precise timing operation • 32.7688 kHz Low-speed eXternal crystal oscillator (LXT) for RTC function and low-power system operation • Supports clock failure detection for external crystal oscillators and exception generation (NMI)
Internal Clock Source	<ul style="list-style-type: none"> • 12 MHz High-speed Internal RC oscillator (HIRC) trimmed to 2% accuracy that can optionally be used as a system clock • 10 kHz Low-speed Internal RC oscillator (LIRC) for watchdog timer and wakeup operation

- Up to 480 MHz on-chip PLL, sourced from HIRC or HXT, allows CPU operation up to the maximum CPU frequency without the need for a high-frequency crystal

Real-Time Clock (RTC)

- Real-Time Clock with a separate power domain
- The RTC clock source includes Low-speed external crystal oscillator (LXT)
- The RTC block includes 80 bytes backup registers, which can be cleared by tamper pins
- Supports 6 static and dynamic tamper pins
- Able to wake up CPU from any reduced power mode
- Supports ± 5 ppm within 5 seconds software clock accuracy compensation
- Supports Alarm registers (second, minute, hour, day, month, year)
- Supports RTC Time Tick and Alarm Match interrupt
- Automatic leap year recognition
- Supports 1 Hz clock output for calibration

Timers

32-bit Timer

TIMER

- Four sets of 32-bit timers with 24-bit up counter and one 8-bit pre-scale counter from independent clock source
- One-shot, Periodic, Toggle and Continuous Counting operation modes
- Supports event counting function to count the event from external pins
- Supports external capture pin for interval measurement and resetting 24-bit up counter
- Supports chip wake-up function, if a timer interrupt signal is generated

PWM

- Eight 16-bit PWM counters with 12-bit clock prescale
- Supports 12-bit deadband (dead time)
- Up, down or up-down PWM counter type
- Supports brake function
- Supports mask function and tri-state output for each PWM channel

Enhanced PWM (EPWM)

- Twelve 16-bit counters with 12-bit clock prescale for twelve 192 MHz PWM output channels
- Up to 12 independent input capture channels with 16-bit resolution counter
- Supports dead time with maximum divided 12-bit prescale
- Up, down or up-down PWM counter type
- Supports complementary mode for 3 complementary paired PWM output channels

	<ul style="list-style-type: none"> • Synchronous function for phase control • Counter synchronous start function • Brake function with auto recovery mechanism • Mask function and tri-state output for each PWM channel • Able to trigger EADC or DAC to start conversion
Basic PWM (BPWM)	<ul style="list-style-type: none"> • Two 16-bit counters with 12-bit clock prescale for twelve 192 MHz PWM output channels. • Up to 6 independent input capture channels with 16-bit resolution counter • Up, down or up-down PWM counter type • Counter synchronous start function • Complementary mode for 3 complementary paired PWM output channels • Mask function and tri-state output for each PWM channel • Able to trigger EADC to start conversion.
Watchdog	<ul style="list-style-type: none"> • 18-bit free running up counter for WDT time-out interval • Supports multiple clock sources from LIRC (default selection), HCLK/2048 and LXT with 8 selectable time-out period • Able to wake up system from Power-down or Idle mode • Time-out event to trigger interrupt or reset system • Supports four WDT reset delay periods, including 1026, 130, 18 or 3 WDT_CLK reset delay period • Configured to force WDT enabled on chip power-on or reset.
Window Watchdog	<ul style="list-style-type: none"> • Clock sourced from HCLK/2048 or LIRC; the window set by 6-bit counter with 11-bit prescale • Suspended in Idle/Power-down mode
Analog Interfaces	
Enhanced Analog-to-Digital Converter (EADC)	<ul style="list-style-type: none"> • One 12-bit, 19-ch 5 MSPS SAR EADC with up to 16 single-ended input channels or 8 differential input pairs; 10-bit accuracy is guaranteed. • Three internal channels for band-gap VBG input and Temperature sensor input • Supports external VREF pin or internal reference voltage VREF: 1.6V, 2.0V, 2.5V, and 3.0V. • Two power saving modes: Power-down mode and Standby mode • Supports calibration capability. • Analog-to-Digital conversion can be triggered by software enable, external pin, Timer 0~3 overflow pulse trigger or PWM trigger. • Configurable EADC sampling time. • Up to 19 sample modules.

	<ul style="list-style-type: none"> • Double data buffers for sample module 0~3. • PDMA operation.
Digital-to-Analog Converter (DAC)	<ul style="list-style-type: none"> • Two 12-bit, 1 MSPS voltage type DAC with 8-bit mode and 8μs rail-to-rail settle time. • Maximum output voltage $AV_{DD} - 0.2V$ at buffer mode • Digital-to-Analog conversion triggered by Timer0~3, EPWM0, EPWM1, external trigger pin to start DAC conversion or software. • Supports group mode for synchronized data update of two DACs. • PDMA operation
Analog Comparator (ACMP)	<ul style="list-style-type: none"> • Two rail-to-rail Analog Comparators. • Supports four multiplexed I/O pins at positive input. • Supports I/O pins, band-gap, DAC, and 16-level Voltage divider from AV_{DD} or V_{REF} at negative input • Supports four programmable propagation speeds for power saving • Supports wake up from Power-down by interrupt • Supports triggers for brake events and cycle-by-cycle control for PWM • Supports window compare mode and window latch mode. • Supports programmable hysteresis window: 0mV, 10mV, 20mV and 30mV
Operational Amplifier (OPA)	<ul style="list-style-type: none"> • Three Operational Amplifiers with 0~AV_{DD} input voltage range. • OPA schmitt trigger buffer output used as the interrupt source of comparator.

Communication Interfaces

Low-power UART	<ul style="list-style-type: none"> • Six sets of UARTs with up to 17.45 MHz baud rate. • Auto-Baud Rate measurement and baud rate compensation function. • Supports low power UART (LPUART): baud rate clock from LXT(32.768 KHz) with 9600bps in Power-down mode even system clock is stopped. • 16-byte FIFOs with programmable level trigger • Auto flow control (nCTS and nRTS) • Supports IrDA (SIR) function • Supports LIN function on UART0 and UART1 • Supports RS-485 9-bit mode and direction control • Supports nCTS, incoming data, Received Data FIFO reached threshold and RS-485 Address Match (AAD mode) wake-up function in idle mode. • Supports hardware or software enables to program nRTS pin to control RS-485 transmission direction • Supports wake-up function
-----------------------	---

	<ul style="list-style-type: none"> • 8-bit receiver FIFO time-out detection function • Supports break error, frame error, parity error and receive/transmit FIFO overflow detection function • PDMA operation.
<p>Smart Card Interface</p>	<ul style="list-style-type: none"> • Three sets of ISO-7816-3 which are compliant with ISO-7816-3 T=0, T=1 • Supports full duplex UART function. • 4-byte FIFOs with programmable level trigger • Programmable guard time selection (11 ETU ~ 266 ETU) • One 24-bit and two 8 bit time-out counters for Answer to Request (ATR) and waiting times processing • Auto inverse convention function • Stop clock level and clock stop (clock keep) function • Transmitter and receiver error retry function • Supports hardware activation, deactivation and warm reset sequence process • Supports hardware auto deactivation sequence after card removal.
<p>I²C</p>	<ul style="list-style-type: none"> • Three sets of I²C devices with Master/Slave mode. • Supports Standard mode (100 kbps), Fast mode (400 kbps) and Fast mode plus (1 Mbps) • Supports 10 bits mode • Programmable clocks allowing for versatile rate control • Supports multiple address recognition (four slave address with mask option) • Supports SMBus and PMBus • Supports multi-address power-down wake-up function • PDMA operation
<p>SPI Master (SPI Flash)</p>	<ul style="list-style-type: none"> • Maximum 32 MB external SPI Flash memory with standard (1-bit), dual (2-bit) and quad (4-bit) transfer mode. • 32 KB cache memory for enhancing program execution performance. • 64-bit key length for code protection. • DMA mode for code transfer between SPI Flash memory and SRAM. • SPI Master function with 8-, 16-, 24-, and 32-bit length of transaction and burst mode operation, which can transmit/receive data up to four successive transactions in one transfer.
<p>Quad SPI</p>	<ul style="list-style-type: none"> • One set of SPI Quad controller with Master/Slave mode, up to 96 MHz at 2.7V~3.6V system voltage. • Supports Dual and Quad I/O Transfer mode • Supports one/two data channel half-duplex transfer • Supports receive-only mode

	<ul style="list-style-type: none"> • Configurable bit length of a transfer word from 8 to 32-bit • Provides separate 8-level depth transmit and receive FIFO buffers • Supports MSB first or LSB first transfer sequence • Supports the byte reorder function • Supports Byte or Word Suspend mode • Supports 3-wired, no slave select signal, bi-direction interface • PDMA operation.
<p>SPI/I²S</p>	<ul style="list-style-type: none"> • Up to four sets of SPI/I²S controllers with Master/Slave mode. • SPI/I²S provides separate 4-level of 32-bit (or 8-level of 16-bit) transmit and receive FIFO buffers. <p>SPI</p> <ul style="list-style-type: none"> • SPI can communicate at up to 96 Mbit/s • Configurable bit length of a transfer word from 8 to 32-bit. • MSB first or LSB first transfer sequence. • Byte reorder function. • Supports Byte or Word Suspend mode. • Supports one data channel half-duplex transfer. • Supports receive-only mode. <p>I²S</p> <ul style="list-style-type: none"> • Supports mono and stereo audio data with 8-, 16-, 24- and 32-bit audio data sizes. • Supports PCM mode A, PCM mode B, I²S and MSB justified data format. • PDMA operation.
<p>I²S</p>	<ul style="list-style-type: none"> • One set of I²S interface with Master/Slave mode. • Supports mono and stereo audio data with 8-, 16-, 24- and 32-bit word sizes. • Two 16-level FIFO data buffers, one for transmitting and the other for receiving. • Supports I²S protocols: Philips standard, MSB-justified, and LSB-justified data format. • Supports PCM protocols: PCM standard, MSB-justified, and LSB-justified data format. • PCM protocol supports TDM multi-channel transmission in one audio sample; the number of data channel can be set as 2, 4, 6 or 8. • PDMA operation.
<p>Universal Serial Control Interface (USCI)</p>	<ul style="list-style-type: none"> • Two sets of USCI, configured as UART, SPI or I²C function. • Supports single byte TX and RX buffer mode <p>UART</p> <ul style="list-style-type: none"> • Supports one transmit buffer and two receive buffers for data

payload.

- Supports hardware auto flow control function and programmable flow control trigger level.
- 9-bit Data Transfer.
- Baud rate detection by built-in capture event of baud rate generator.
- Supports wake-up function.
- PDMA operation.

SPI

- Supports Master or Slave mode operation.
- Supports one transmit buffer and two receive buffer for data payload.
- Supports additional receive/transmit 16 entries FIFO for data payload.
- Configurable bit length of a transfer word from 4 to 16-bit (SPI Quad transmission only supports 8 to 16-bit of word length).
- Supports MSB first or LSB first transfer sequence.
- Supports Word Suspend function.
- Supports 3-wire, no slave select signal, bi-direction interface.
- Supports wake-up function: input slave select transition.
- PDMA operation.

I²C

- Supports master and slave device capability.
- Supports one transmit buffer and two receive buffer for data payload.
- Communication in standard mode (100 kbps), fast mode (up to 400 kbps), and Fast mode plus (1 Mbps).
- Supports 10-bit mode.
- Supports 10-bit bus time out capability.
- Supports bus monitor mode.
- Supports power-down wake-up by data toggle or address match.
- Supports multiple address recognition.
- Supports device address flag.
- Programmable setup/hold time.

Controller Area Network (CAN)

- Two sets of CAN 2.0B controllers.
- Each supports 32 Message Objects; each Message Object has its own identifier mask.
- Programmable FIFO mode (concatenation of Message Object).
- Disabled Automatic Re-transmission mode for Time Triggered CAN applications.
- Supports power-down wake-up function.

Secure Digital Host Controller (SDHC)

- Two sets of Secure Digital Host Controllers, compliant with SD Memory Card Specification Version 2.0.

	<ul style="list-style-type: none"> • Supports 50 MHz to achieve 200 Mbps at 3.3V operation. • Supports dedicated DMA master with Scatter-Gather function to accelerate the data transfer between system memory and SD/SDHC/SDIO card.
--	---

<p>External Bus Interface (EBI)</p>	<ul style="list-style-type: none"> • Supports up to three memory banks with individual adjustment of timing parameter. • Each bank supports dedicated external chip select pin with polarity control and up to 1 MB addressing space. • 8-/16-bit data width. • Supports byte write in 16-bit data width mode. • Configurable idle cycle for different access condition: Idle of Write command finish (W2X) and Idle of Read-to-Read (R2R). • Supports Address/Data multiplexed mode. • Supports address bus and data bus separate mode. • Supports LCD interface i80 mode. • PDMA operation.
--	--

<p>GPIO</p>	<ul style="list-style-type: none"> • Supports three I/O modes: Push-Pull output, Open-Drain output and Input only with high impedance mode. • Selectable TTL/Schmitt trigger input. • Configured as interrupt source with edge/level trigger setting. • Supports independent pull-up/pull-down control. • Supports high driver and high sink current I/O. • Supports software selectable slew rate control. • Supports 5V-tolerance function except analog I/O.
--------------------	--

Control Interfaces

<p>Quadrature Encoder Interface (QEI)</p>	<ul style="list-style-type: none"> • Two QEI phase inputs (QEI_A, QEI_B) and one Index input (QEI_INDEX). • Supports 2/4 times free-counting mode and 2/4 compare-counting mode. • Supports encoder pulse width measurement mode with ECAP.
--	--

	<p>Input Capture Timer/Counter</p> <ul style="list-style-type: none"> • Supports three input channels with independent capture counter hold register.
<p>Enhanced Capture (ECAP)</p>	<ul style="list-style-type: none"> • 24-bit Input Capture up-counting timer/counter supports captured events reset and/or reload capture counter. • Supports rising edge, falling edge and both edge detector options with noise filter in front of input ports. • Supports compare-match function.

Advanced Connectivity

USB 2.0 Full Speed with on-chip transceiver

USB 2.0 Full Speed OTG (On-The-Go)

- On-chip USB 2.0 full speed OTG transceiver.
- Compliant with USB OTG Supplement 2.0
- Configurable as host-only, device-only or ID-dependent

USB 2.0 Full Speed Host Controller

- Compliant with USB Revision 1.1 Specification.
- Compatible with OHCI (Open Host Controller Interface) Revision 1.0.
- Supports full-speed (12Mbps) and low-speed (1.5Mbps) USB devices.
- Supports Control, Bulk, Interrupt, Isochronous and Split transfers.
- Integrated a port routing logic to route full/low speed device to OHCI controller.
- Supports an integrated Root Hub.
- Supports port power control and port over current detection.
- Built-in DMA.

USB 2.0 Full Speed Device Controller

- Compliant with USB Revision 2.0 Specification.
- Supports suspend function when no bus activity existing for 3 ms.
- 12 configurable endpoints for configurable Isochronous, Bulk, Interrupt and Control transfer types.
- 1024 bytes configurable RAM for endpoint buffer.
- Remote wake-up capability.

USB 2.0 High Speed with on-chip transceiver

USB 2.0 High Speed OTG (On-The-Go)

- On-chip USB 2.0 high speed OTG transceiver.
- Compliant with USB OTG Supplement 2.0.
- Configurable as host-only, device-only or ID-dependent.

USB 2.0 High Speed Host Controller

- Compliant with USB Revision 2.0 Specification.
- Compatible with EHCI (Enhanced Host Controller Interface) Revision 1.0.
- Compatible with OHCI (Open Host Controller Interface) Revision 1.0.
- Supports high-speed (480Mbps), full-speed (12Mbps) and low-speed (1.5Mbps) USB devices.
- Integrated a port routing logic to route full/low speed device to OHCI controller.
- Supports an integrated Root Hub.
- Built-in DMA.

USB 2.0 High Speed Device Controller

- Compliant with USB Revision 2.0 Specification.
- Supports one dedicate control endpoint and 12 configurable

	<ul style="list-style-type: none"> endpoints; each can be Isochronous, Bulk or Interrupt and either IN or OUT direction. • 4096 bytes configurable RAM for endpoint buffer and up to 1024 bytes maximum packet size. • Three different operation modes of an in-endpoint: Auto Validation mode, Manual Validation mode and Fly mode. • Suspend, resume and remote wake-up capability. • Built-in DMA.
--	--

Ethernet MAC

	<ul style="list-style-type: none"> • IEEE Std. 802.3 CSMA/CD protocol. • Ethernet frame time stamping for IEEE Std. 1588 – 2002 protocol. • Supports both half and full duplex for 10 Mbps or 100 Mbps operation. • RMI (Reduced Media Independent Interface) and serial management interface (MDC/MDIO). • Pause and remote pause function for flow control. • Long frame (more than 1518 bytes) and short frame (less than 64 bytes) reception. • CAM function for Ethernet MAC address recognition. • Supports Magic Packet recognition to wake system up from Power-down mode. • Built-in DMA.
--	---

Cryptography Accelerator

	<ul style="list-style-type: none"> • Hardware ECC accelerator. • Supports 192-bit and 256-bit key length. • Supports both prime field GF(p) and binary field GF(2^m). • Supports NIST P-192, P-224, P-256, P-384 and P-521 curve sizes. • Supports NIST B-163, B-233, B-283, B-409 and B-571 curve sizes. • Supports NIST K-163, K-233, K-283, K-409 and K-571 curve sizes. • Supports point multiplication, addition and doubling operations in GF(p) and GF(2^m). • Supports modulus division, multiplication, addition and subtraction operations in GF(p).
--	--

Advanced Encryption Standard (AES)

	<ul style="list-style-type: none"> • Hardware AES accelerator. • Supports 128-bit, 192-bit and 256-bit key length and key expander, and is compliant with FIPS 197. • Supports ECB, CBC, CFB, OFB, CTR, CBC-CS1, CBC-CS2 and CBC-CS3 block cipher modes • Compliant with NIST SP800-38A and addendum.
--	---

Data Encryption Standard (DES)

	<ul style="list-style-type: none"> • Hardware DES accelerator. • Supports ECB, CBC, CFB, OFB, and CTR block cipher mode.
--	--

	<ul style="list-style-type: none"> Compliant with FIPS 46-3.
Triple Data Encryption Standard (3DES)	<ul style="list-style-type: none"> Hardware Triple DES accelerator. Supports two or three different keys in each round. Supports ECB, CBC, CFB, OFB, and CTR block cipher mode. Implemented based on X9.52 standard and compliant with FIPS SP 800-67.
Secure Hash Algorithm (SHA)	<ul style="list-style-type: none"> Hardware SHA accelerator. Supports SHA-160, SHA-224, SHA-256, SHA-384 and SHA-512. Compliant with FIPS 180/180-2.
keyed-Hash Message Authentication Code (HMAC)	<ul style="list-style-type: none"> Hardware HMAC accelerator. Supports HMAC-SHA-160, HMAC-SHA-224, HMAC-SHA-256, HMAC-SHA-384, and HMAC-SHA-512. Compliant with FIPS 180/180-2.

3 PARTS INFORMATION

3.1 Summary

Part No.	USB FS	USB HS	CAN	Crypto	Ethernet
M481	–	–	–	–	–
M482	√	–	–	–	–
M483	√	√	√	–	–
M484	√	√	–	–	–
M485	√	√	–	√	–
M487	√	√	√	√	√

3.2 Package Type

Part No.	QFN33	LQFP48	LQFP64	LQFP128	LQFP144
M481	M481ZGAEE M481ZIDAE	M481LGAEE M481LIDAE	M481SGAEE M481SIDAE		
M482	M482ZIDAE	M482LGAEE M482LIDAE	M482SGAEE M482SIDAE	M482KGAEE M482KIDAE	
M483			M483SGAEE M483SIDAE	M483KIDAE	
M484			M484SGAEE M484SIDAE M484SGAEE2U M484SIDAE2U	M484KIDAE	
M485	M485ZIDAE	M485LIDAE	M485SIDAE	M485KIDAE	
M487			M487SIDAE	M487KIDAE	M487JIDAE

3.3 NuMicro® M481 Base Series

PART NUMBER		M481					
		ZGAEE	ZIDAE	LGAAE	LIDAE	SGAAE	SIDAE
Flash (KB)		256	512	256	512	256	512
SRAM (KB)		96	160	96	160	96	160
ISP Loader ROM (KB)		4					
I/O		26		41		52	
32-bit Timer		4					
Tamper		-		-		1	
Connectivity	LPUART	6					
	ISO-7816	3					
	SPI Master	1					
	Quad SPI	1					
	SPI/I ² S	3		3		4	
	I ² S	1					
	I ² C	3					
	USCI	2					
	CAN	-					
	LIN	2					
	SDHC	1		2		2	
16-bit PWM		24					
QEI		1		2		2	
ECAP		-		1		1	
USB 2.0 FS OTG		-					
USB 2.0 HS OTG		-					
12-bit ADC		10		12		16	
12-bit DAC		2					
Analog Comparator		2					
Operational Amplifier		1		2		2	
Ethernet		-					
Cryptography		-					
LCD Parallel Data Bus (External Bus Interface)		-		8		16	
Package		QFN 33		LQFP 48		LQFP 64	

3.4 NuMicro® M482 USB FS OTG Series

PART NUMBER		M482						
		ZIDAE	LGAAE	LIDAE	SGAAE	SIDAE	KGAAE	KIDAE
Flash (KB)		512	256	512	256	512	256	512
SRAM (KB)		160	96	160	96	160	96	160
ISP Loader ROM (KB)		4						
I/O		26	41		52		100	
32-bit Timer		4						
Tamper		-	-		1		6	
Connectivity	LPUART	6						
	ISO-7816	3						
	SPI Master	1						
	Quad SPI	1						
	SPI/I ² S	3	3		4		4	
	I ² S	1						
	I ² C	3						
	USCI	2						
	CAN	-						
	LIN	2						
	SDHC	2						
16-bit PWM		24						
QEI		1	2		2		2	
ECAP		-	1		1		2	
USB 2.0 FS OTG		√						
USB 2.0 HS OTG		-						
12-bit ADC		10	12		16		16	
12-bit DAC		2						
Analog Comparator		2						
Operational Amplifier		1	2		2		3	
Ethernet		-						
Cryptography		-						
LCD Parallel Data Bus (External Bus Interface)		-	8		16		16	
Package		QFN33	LQFP 48		LQFP 64		LQFP 128	

3.5 NuMicro® M483 CAN Series

PART NUMBER	M483		
	SGAAE	SIDAE	KIDAE
Flash (KB)	256	512	512
SRAM (KB)	96	160	160
ISP Loader ROM (KB)	4		
I/O	44		100
32-bit Timer	4		
Tamper	1		6
Connectivity	LPUART	6	
	ISO-7816	3	
	SPI Master	1	
	Quad SPI	1	
	SPI/I ² S	4	
	I ² S	1	
	I ² C	3	
	USCI	2	
	CAN	2	
	LIN	2	
	SDHC	2	
16-bit PWM	24		
QEI	2		
ECAP	1		2
USB 2.0 FS OTG	-		√
USB 2.0 HS OTG		√	
12-bit ADC	16		
12-bit DAC	2		
Analog Comparator	2		
Operational Amplifier	2		3
Ethernet	-		
Cryptography	-		
LCD Parallel Data Bus (External Bus Interface)	8		16
Package	LQFP 64		LQFP 128

3.6 NuMicro® M484 USB HS OTG Series

PART NUMBER	M484					
	SGAAE	SIDAE	SGAAE2U	SIDAE2U	KIDAE	
Flash (KB)	256	512	256	512	512	
SRAM (KB)	96	160	96	160	160	
ISP Loader ROM (KB)	4					
I/O	44		44		100	
32-bit Timer	4					
Tamper	1		1		6	
Connectivity	LPUART	6				
	ISO-7816	3				
	SPI Master	1				
	Quad SPI	1				
	SPI/I ² S	4				
	I ² S	1				
	I ² C	3				
	USCI	2				
	CAN	-				
	LIN	2				
	SDHC	2				
16-bit PWM	24					
QEI	2					
ECAP	1	1		2		
USB 2.0 FS OTG	-	√		√		
USB 2.0 HS OTG	√					
12-bit ADC	16					
12-bit DAC	2					
Analog Comparator	2					
Operational Amplifier	2		2		3	
Ethernet	-					
Cryptography	-					
LCD Parallel Data Bus (External Bus Interface)	8		8		16	
Package	LQFP 64		LQFP 64		LQFP 128	

3.7 NuMicro® M485 Crypto Series

PART NUMBER	M485				
	ZIDAE	LIDAE	SIDAE	KIDAE	
Flash (KB)	512				
SRAM (KB)	160				
ISP Loader ROM (KB)	4				
I/O	26	41	44	100	
32-bit Timer	4				
Tamper	-	-	1	6	
Connectivity	LPUART	6			
	ISO-7816	3			
	SPI Master	1			
	Quad SPI	1			
	SPI/I ² S	3	3	4	4
	I ² S	1			
	I ² C	3			
	USCI	2			
	CAN	-			
	LIN	2			
	SDHC	1	2	2	2
16-bit PWM	24				
QEI	1	2	2	2	
ECAP	-	1	1	2	
USB 2.0 FS OTG	√	√	-	√	
USB 2.0 HS OTG	-	-	√	√	
12-bit ADC	10	12	16	16	
12-bit DAC	2				
Analog Comparator	2				
Operational Amplifier	1	2	2	3	
Ethernet	-				
Cryptography	√				
LCD Parallel Data Bus (External Bus Interface)	-	8	8	16	
Package	QFN33	LQFP 48	LQFP 64	LQFP 128	

3.8 NuMicro® M487 Ethernet Series

PART NUMBER	M487		
	SIDAE	KIDAE	JIDAE
Flash (KB)	512		
SRAM (KB)	160		
ISP Loader ROM (KB)	4		
I/O	44	100	114
32-bit Timer	4		
Tamper	1	6	6
Connectivity	LPUART	6	
	ISO-7816	3	
	SPI Master	1	
	Quad SPI	1	
	SPI/I ² S	4	
	I ² S	1	
	I ² C	3	
	USCI	2	
	CAN	2	
	LIN	2	
	SDHC	2	
16-bit PWM	24		
QEI	2		
ECAP	1	2	2
USB 2.0 FS OTG	-	√	√
USB 2.0 HS OTG	√		
12-bit ADC	16		
12-bit DAC	2		
Analog Comparator	2		
Operational Amplifier	2	3	3
Ethernet	√		
Cryptography	√		
LCD Parallel Data Bus (External Bus Interface)	8	16	16
Package	LQFP 64	LQFP 128	LQFP 144

3.9 NuMicro[®] M480 Naming Rule

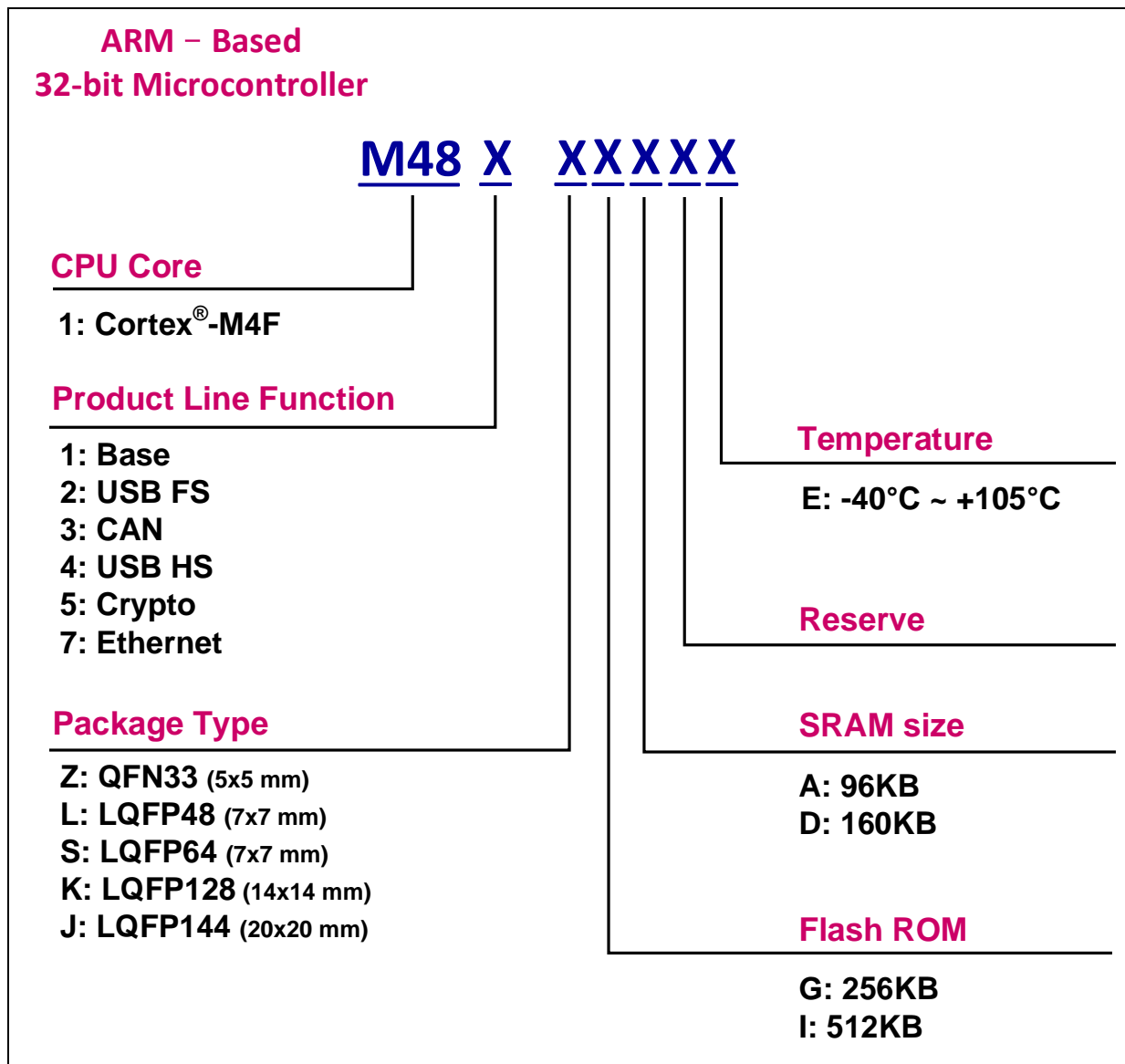

4 PIN CONFIGURATION & DESCRIPTION

4.1 Pin Configuration

4.1.1 NuMicro[®] M481 Base Series QFN33 Pin Diagram

Corresponding Part Number: M481ZGAAE, M481ZIDAE

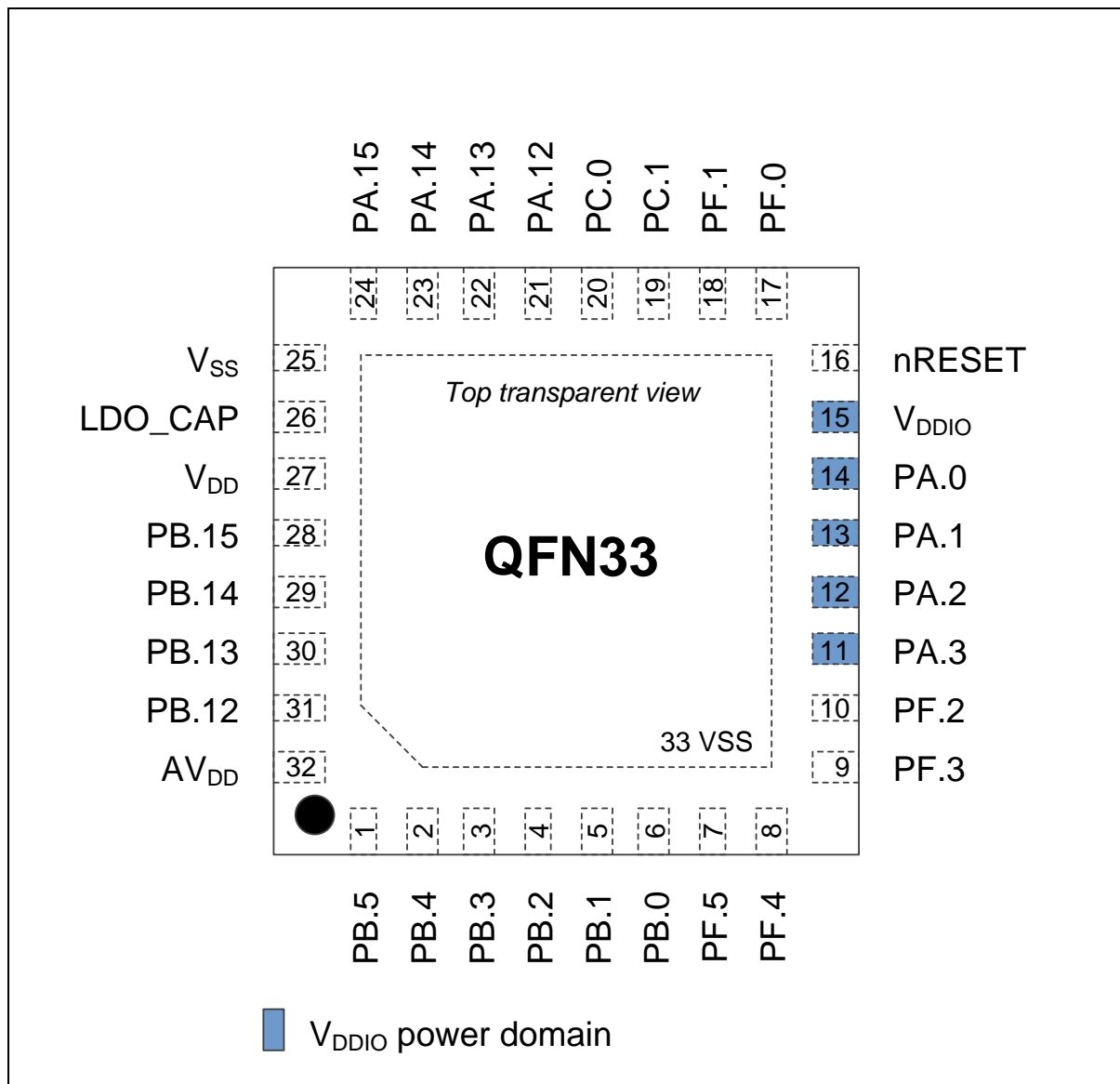

Figure 4.1-1 NuMicro[®] M481 Base Series QFN 33-pin Diagram

4.1.2 NuMicro[®] M481 Base Series LQFP48 Pin Diagram

Corresponding Part Number: M481LGAAE, M481LIDAE

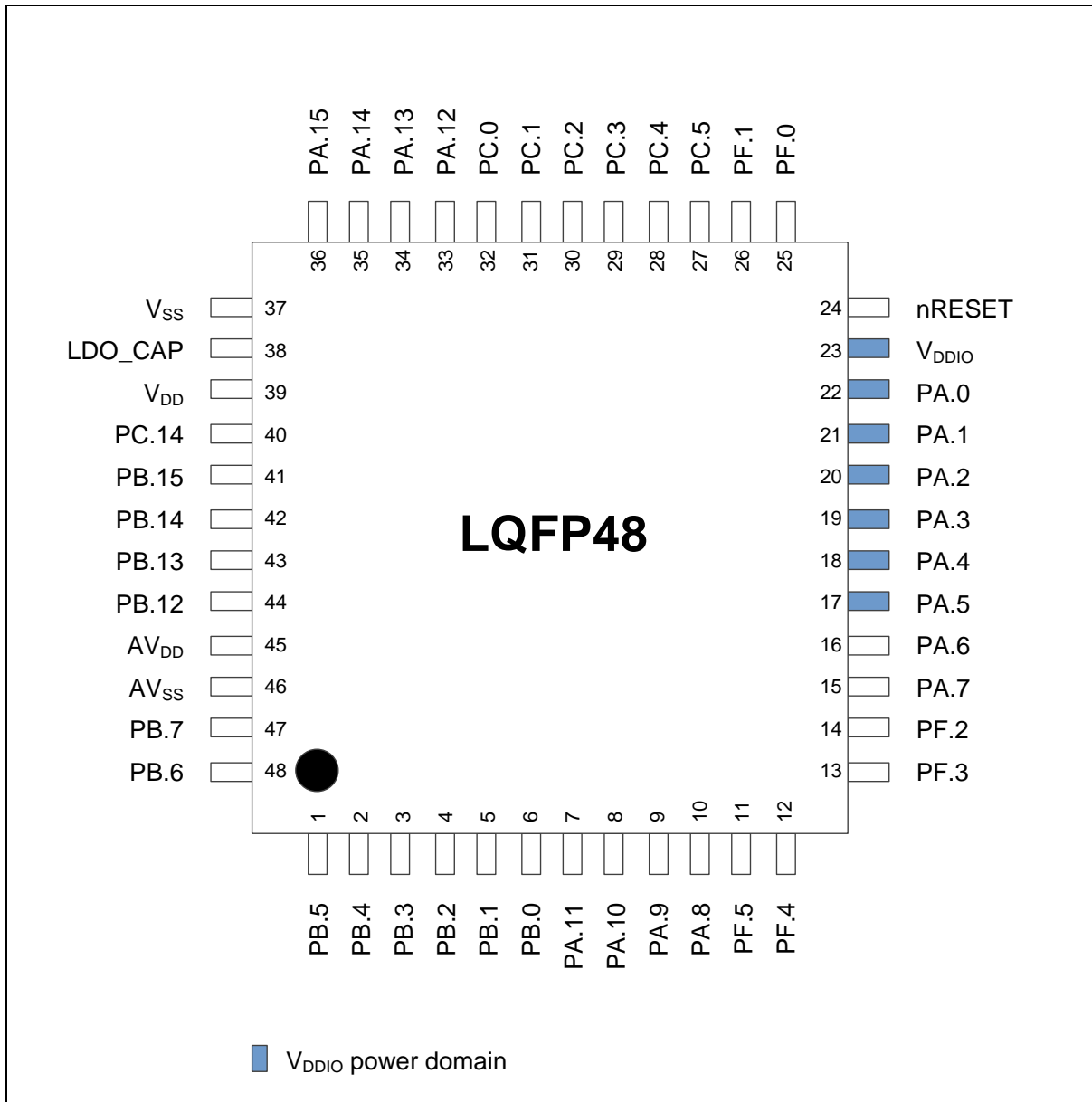

Figure 4.1-2 NuMicro[®] M481 Base Series LQFP 48-pin Diagram

4.1.3 NuMicro[®] M481 Base Series LQFP64 Pin Diagram

Corresponding Part Number: M481SGAAE, M481SIDAE

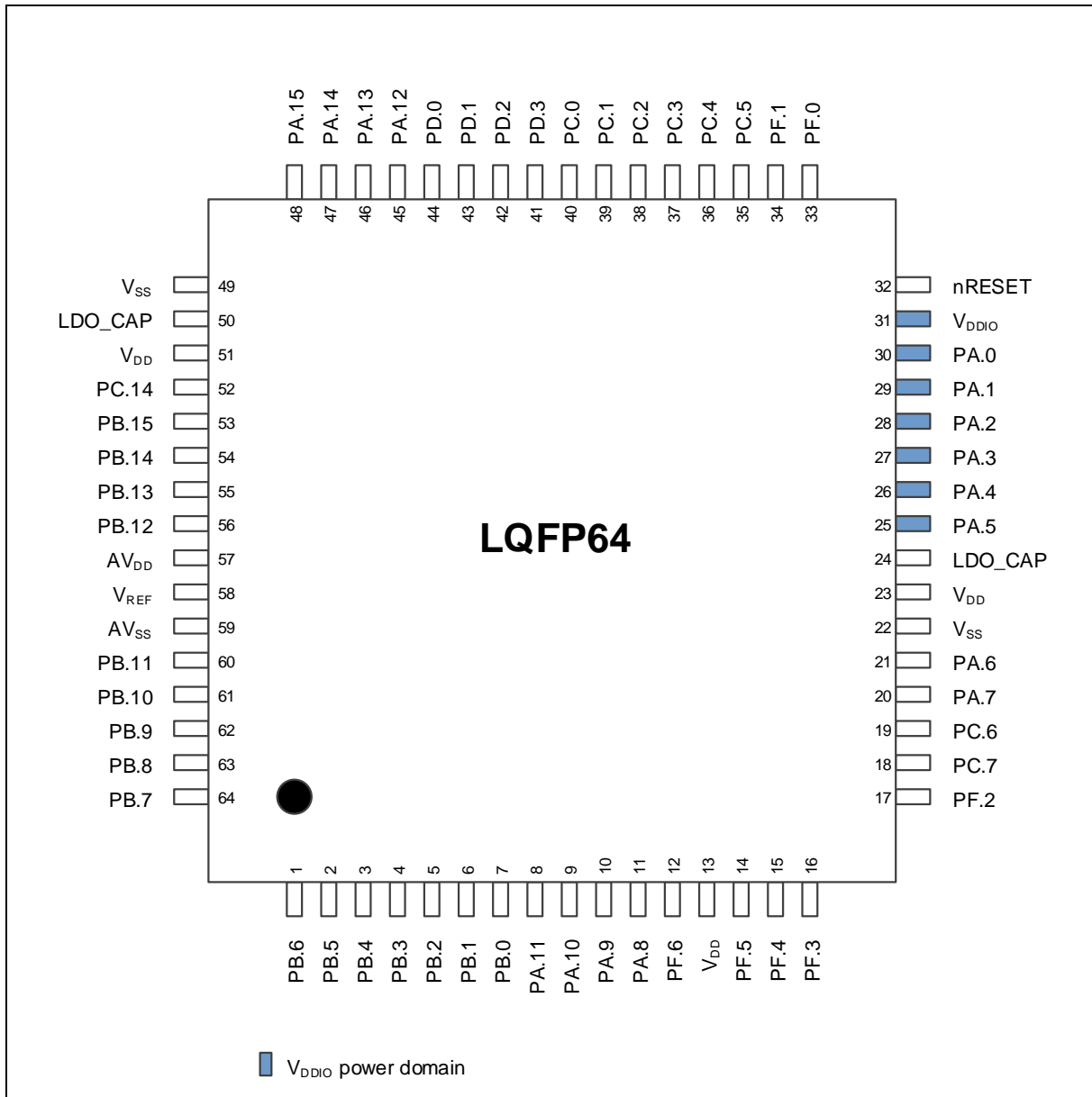

Figure 4.1-3 NuMicro[®] M481 Base Series LQFP 64-pin Diagram

4.1.4 NuMicro® M482 USB FS OTG Series QFN33 Pin Diagram

Corresponding Part Number: M482ZIDAE

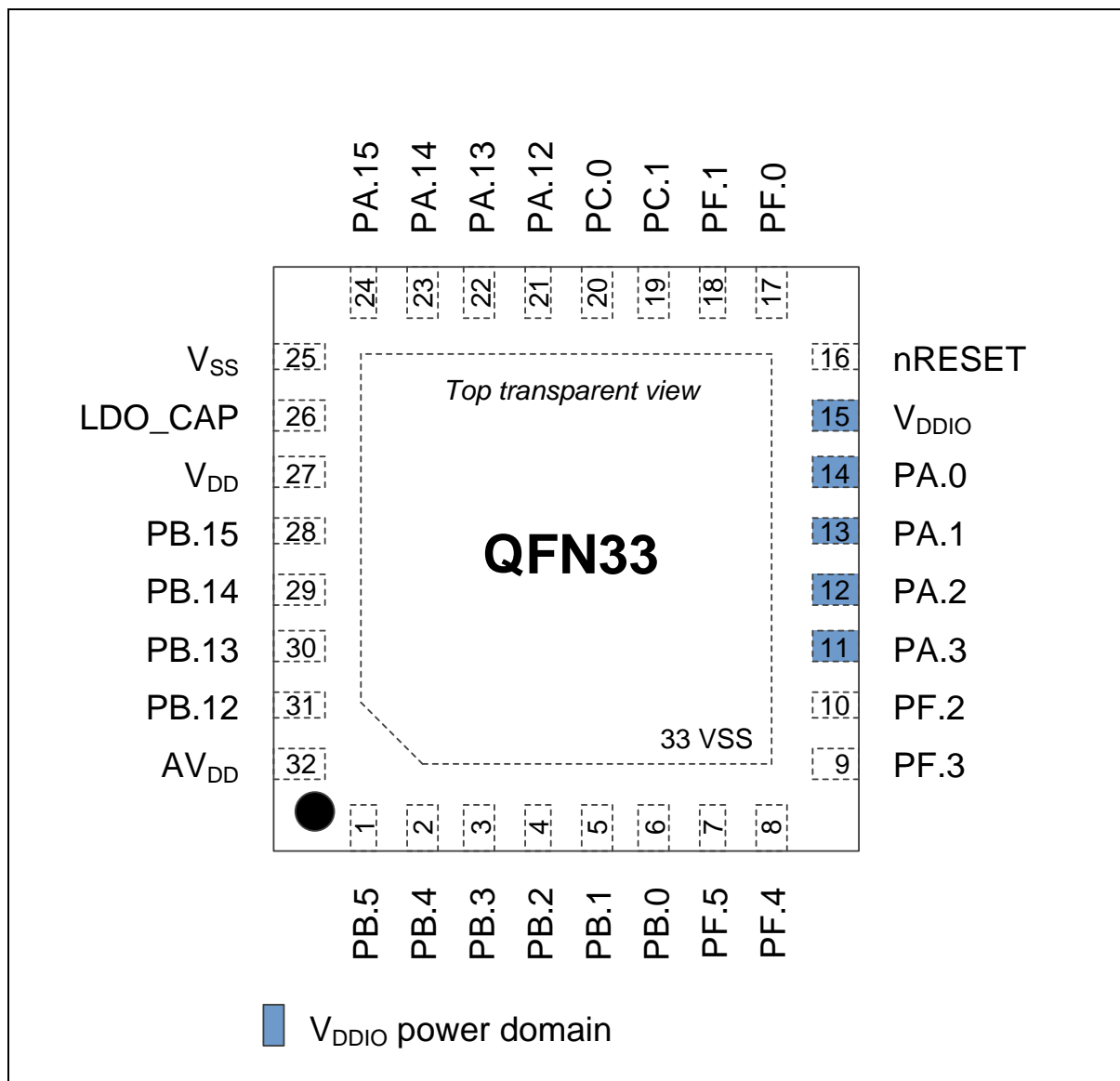

Figure 4.1-4 NuMicro® M482 USB FS OTG Series QFN 33-pin Diagram

4.1.5 NuMicro[®] M482 USB FS OTG Series LQFP48 Pin Diagram

Corresponding Part Number: M482LGAAE, M482LIDAE

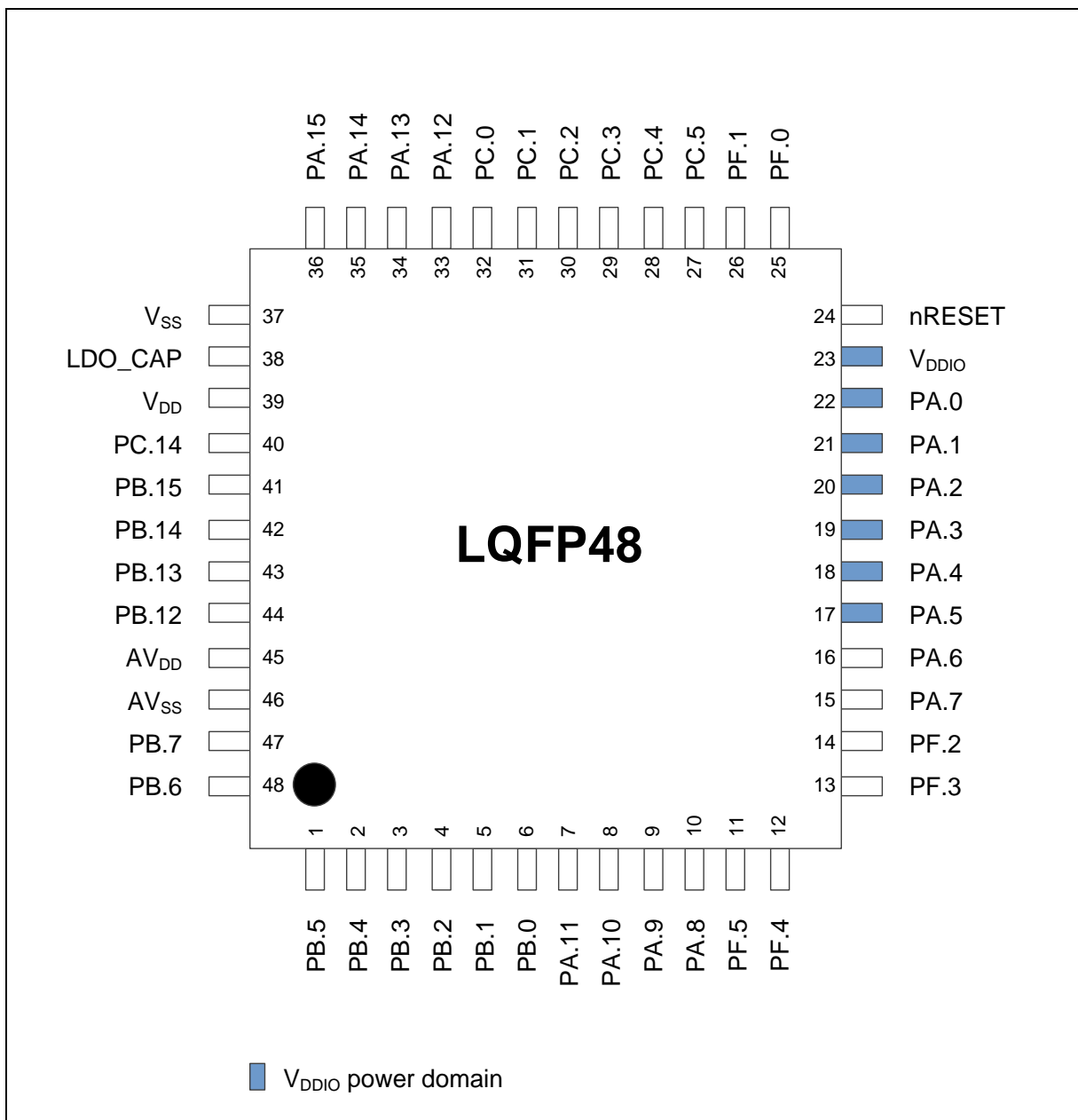

Figure 4.1-5 NuMicro[®] M482 USB FS OTG Series LQFP 48-pin Diagram

4.1.6 NuMicro[®] M482 USB FS OTG Series LQFP64 Pin Diagram

Corresponding Part Number: M482SGAAE, M482SIDAE

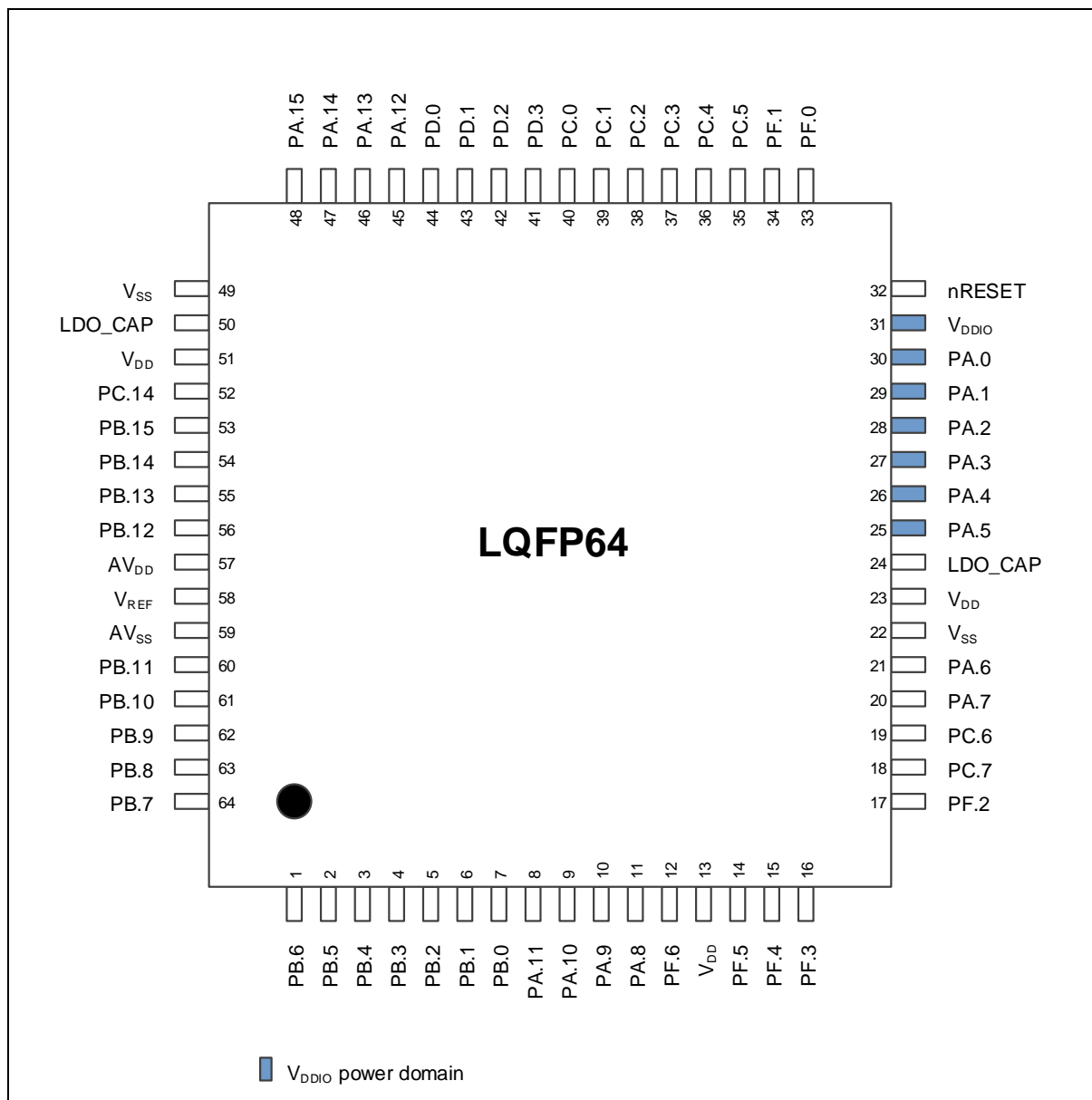

Figure 4.1-6 NuMicro[®] M482 USB FS OTG Series LQFP 64-pin Diagram

4.1.7 NuMicro[®] M482 USB FS OTG Series LQFP128 Pin Diagram

Corresponding Part Number: M482KGAAE, M482KIDAE

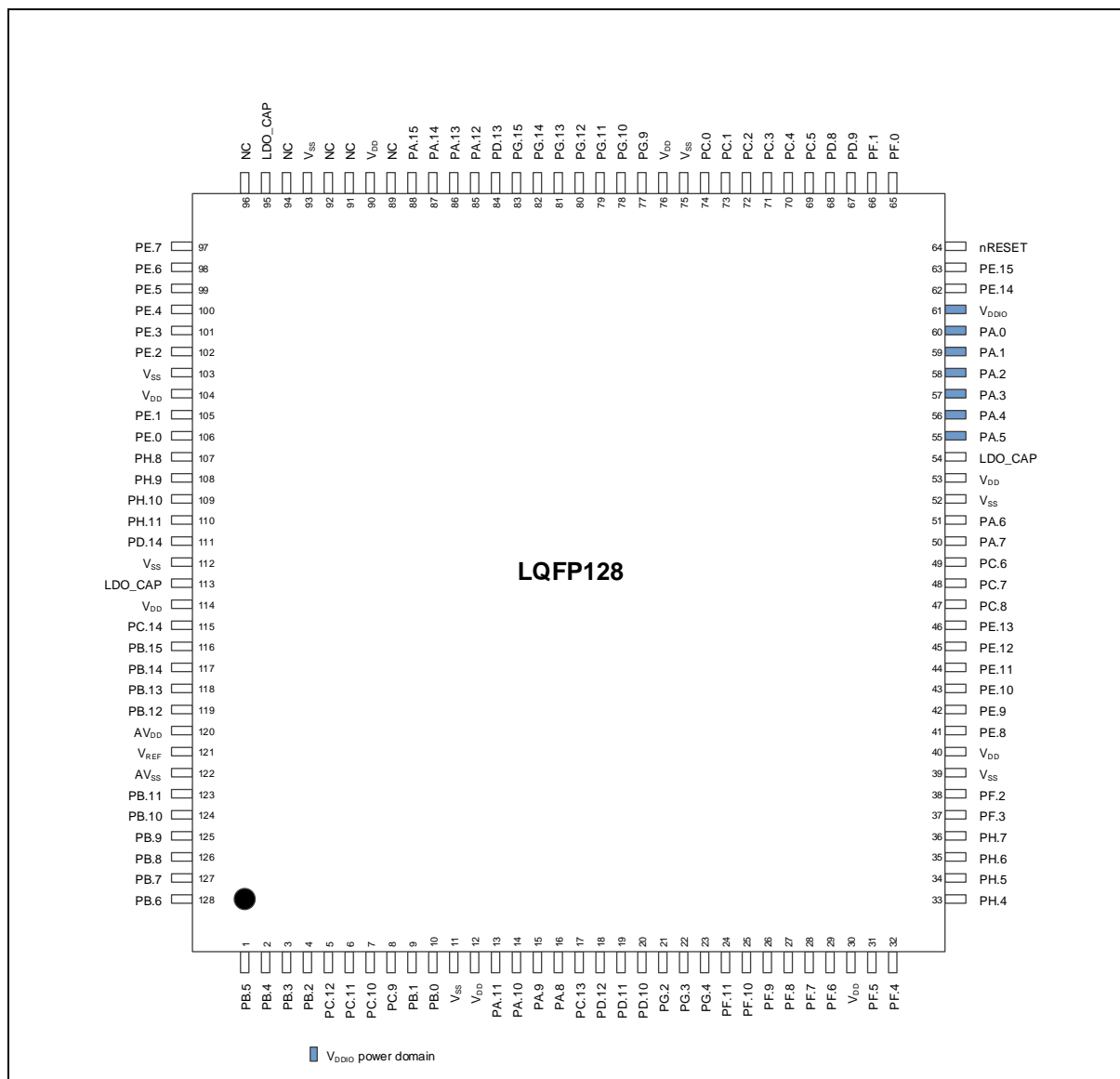

Figure 4.1-7 NuMicro[®] M482 USB FS OTG Series LQFP 128-pin Diagram

4.1.8 NuMicro[®] M483 CAN Series LQFP64 Pin Diagram

Corresponding Part Number: M483SGAAE, M483SIDAE

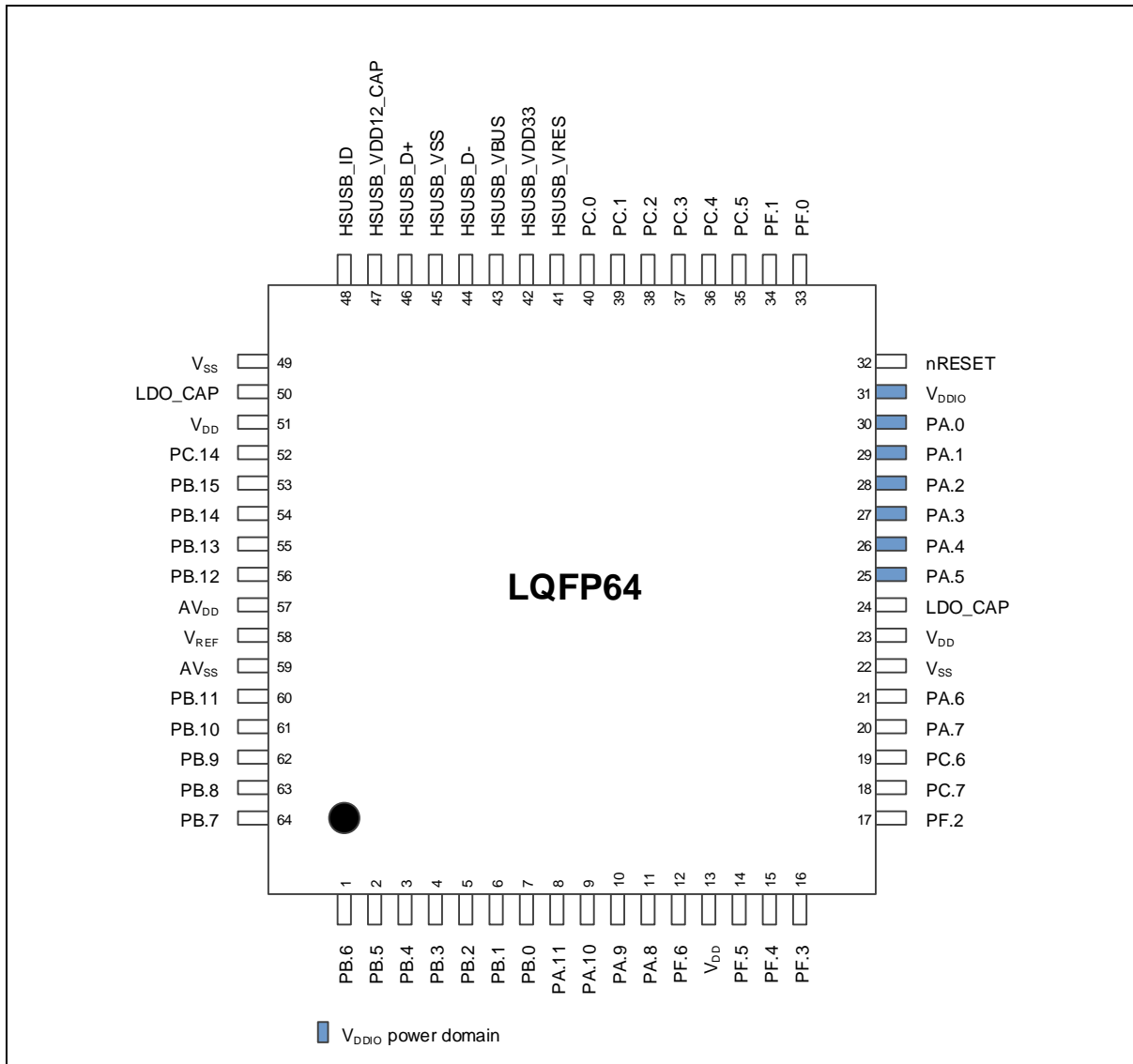

Figure 4.1-8 NuMicro[®] M483 CAN Series LQFP 64-pin Diagram

4.1.9 NuMicro[®] M483 CAN Series LQFP128 Pin Diagram

Corresponding Part Number: M483KIDAE

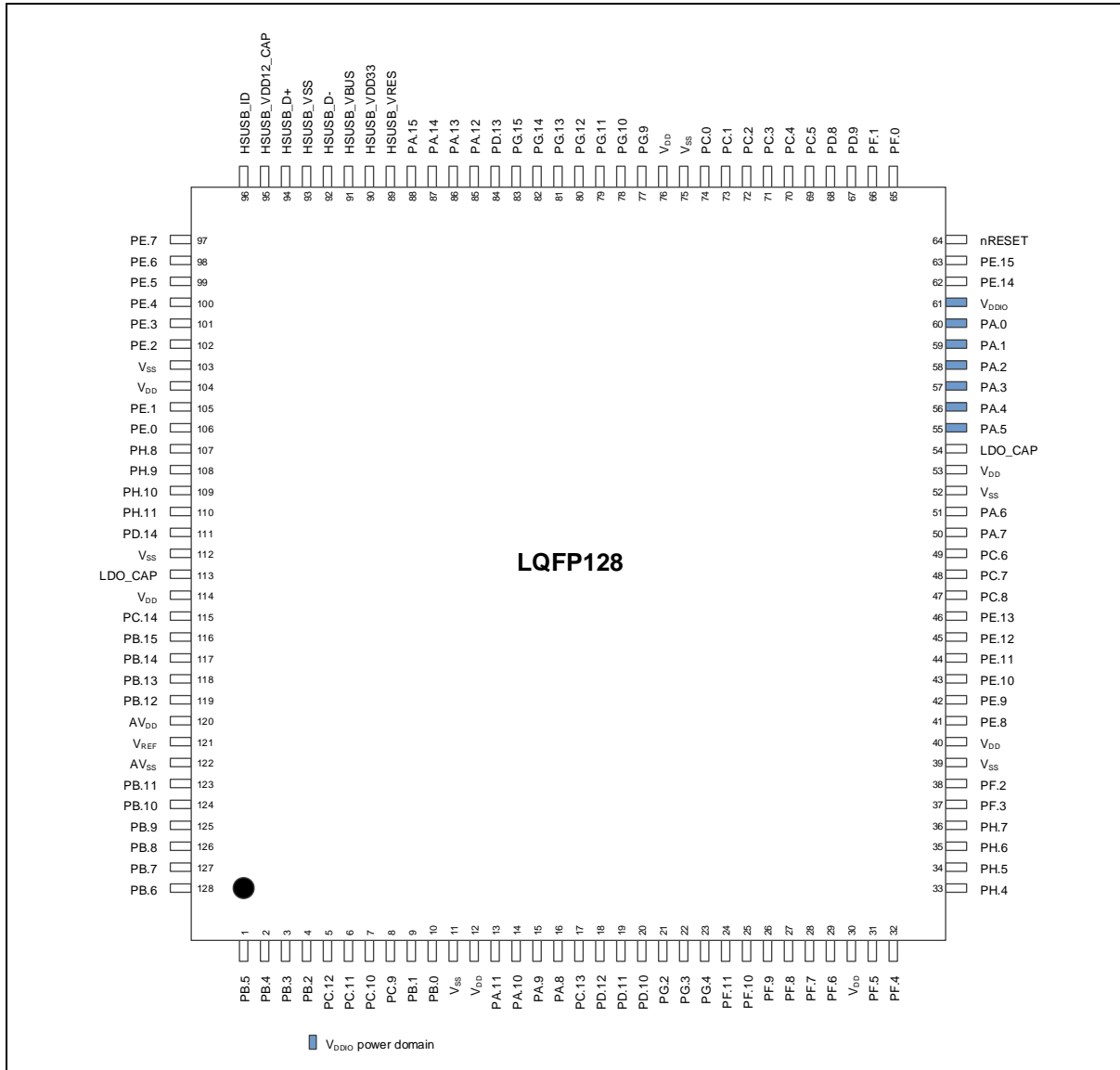

Figure 4.1-9 NuMicro[®] M483 CAN Series LQFP 128-pin Diagram

4.1.10 NuMicro[®] M484 USB HS OTG Series LQFP64 Pin Diagram

Corresponding Part Number: M484SGAAE, M484SIDAE

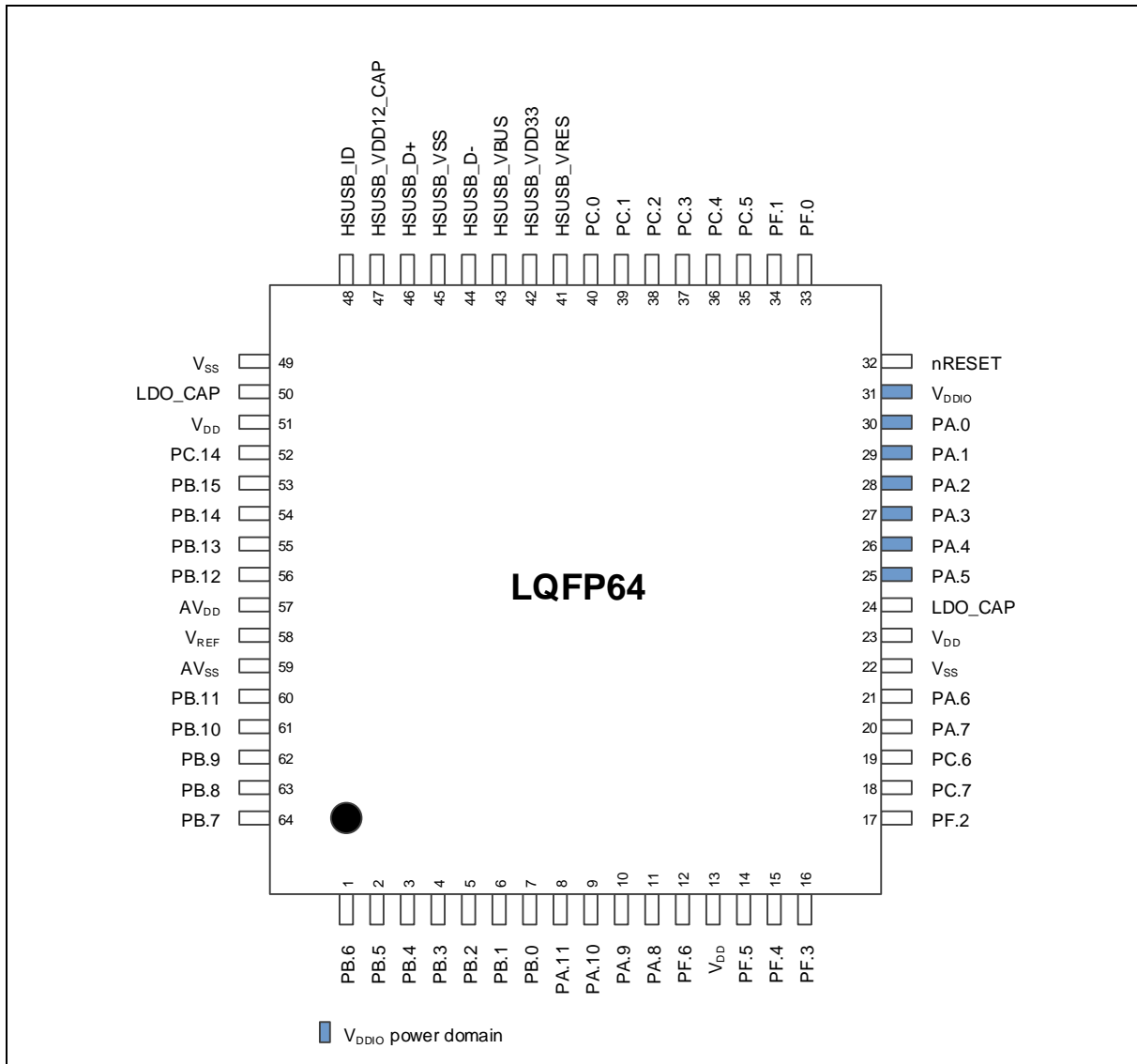

Figure 4.1-10 NuMicro[®] M484 USB HS OTG Series LQFP 64-pin Diagram

4.1.11 NuMicro[®] M484 USB HS OTG Series with 2 USB LQFP64 Pin Diagram

Corresponding Part Number: M484SGAAE2U, M484SIDAE2U

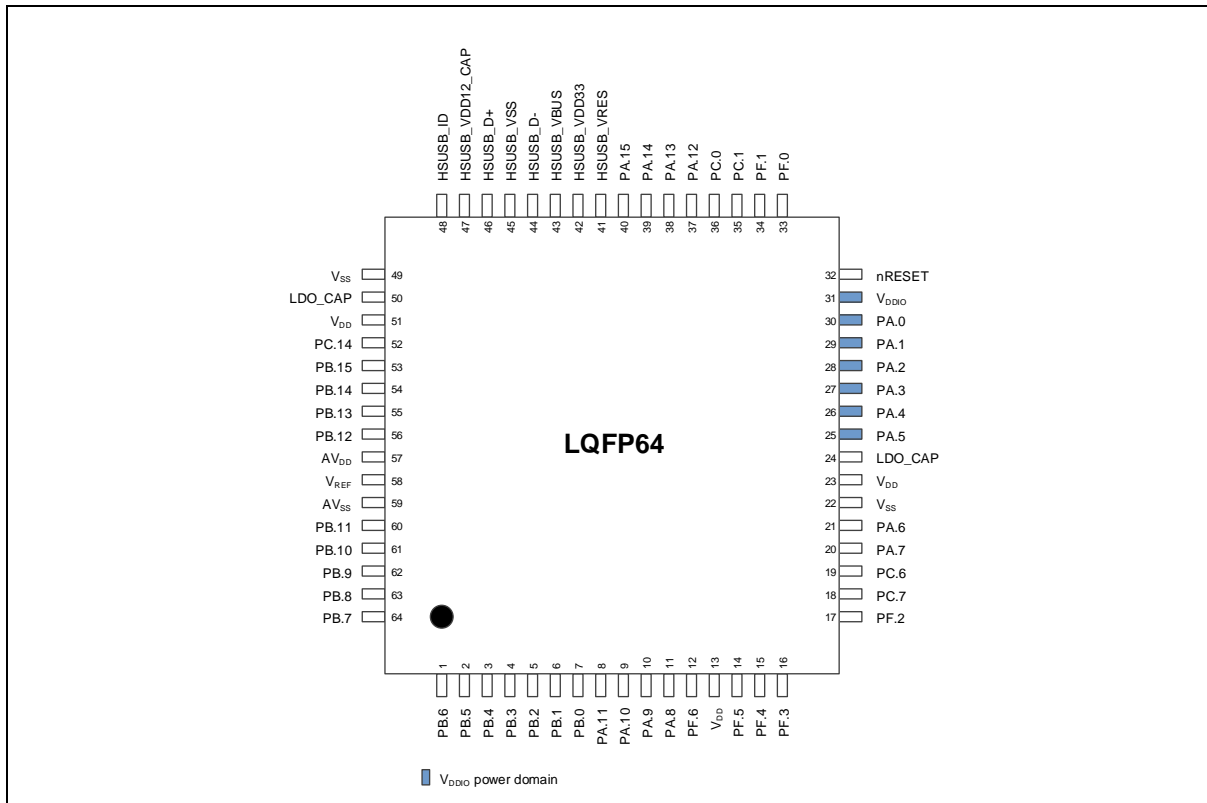

Figure 4.1-11 NuMicro[®] M484 USB HS OTG Series with 2 USB LQFP 64-pin Diagram

4.1.12 NuMicro[®] M484 USB HS OTG Series LQFP128 Pin Diagram

Corresponding Part Number: M484KIDAE

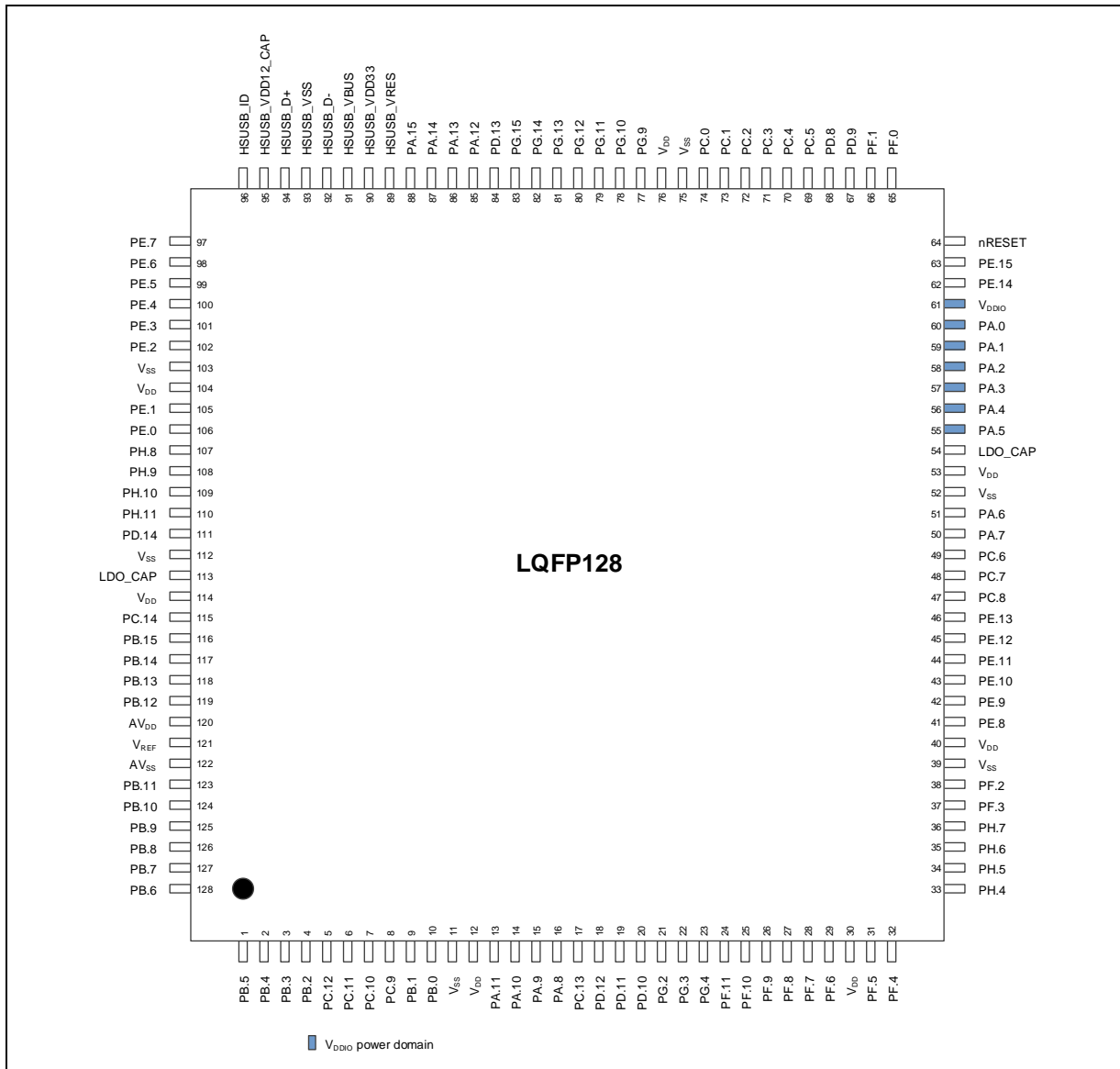

Figure 4.1-12 NuMicro[®] M484 USB HS OTG Series LQFP 128-pin Diagram

4.1.13 NuMicro® M485 Crypto Series QFN33 Pin Diagram

Corresponding Part Number: M485ZIDAE

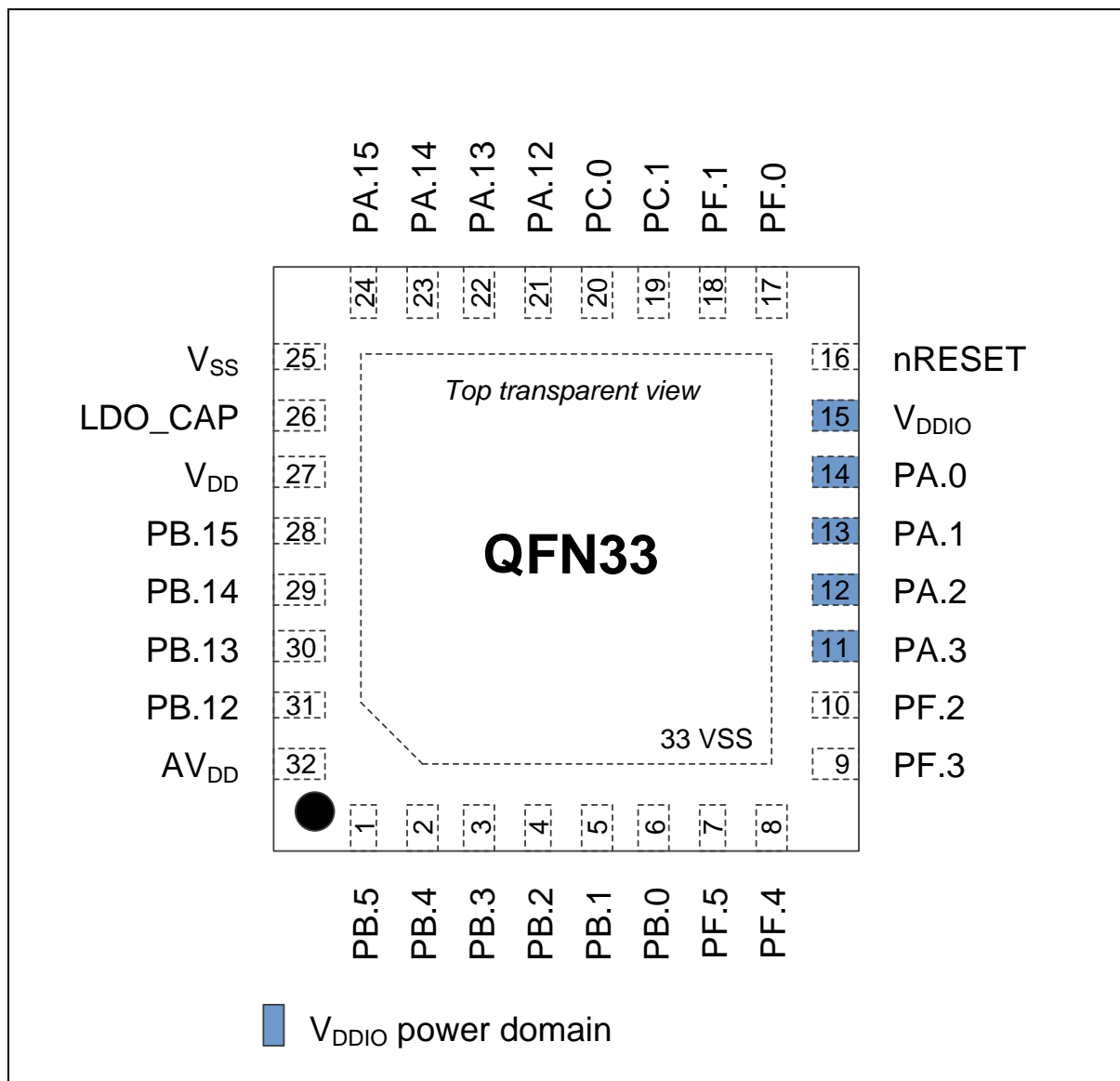

Figure 4.1-13 NuMicro® M485 Crypto Series QFN 33-pin Diagram

4.1.14 NuMicro[®] M485 Crypto Series LQFP48 Pin Diagram

Corresponding Part Number: M485LIDAE

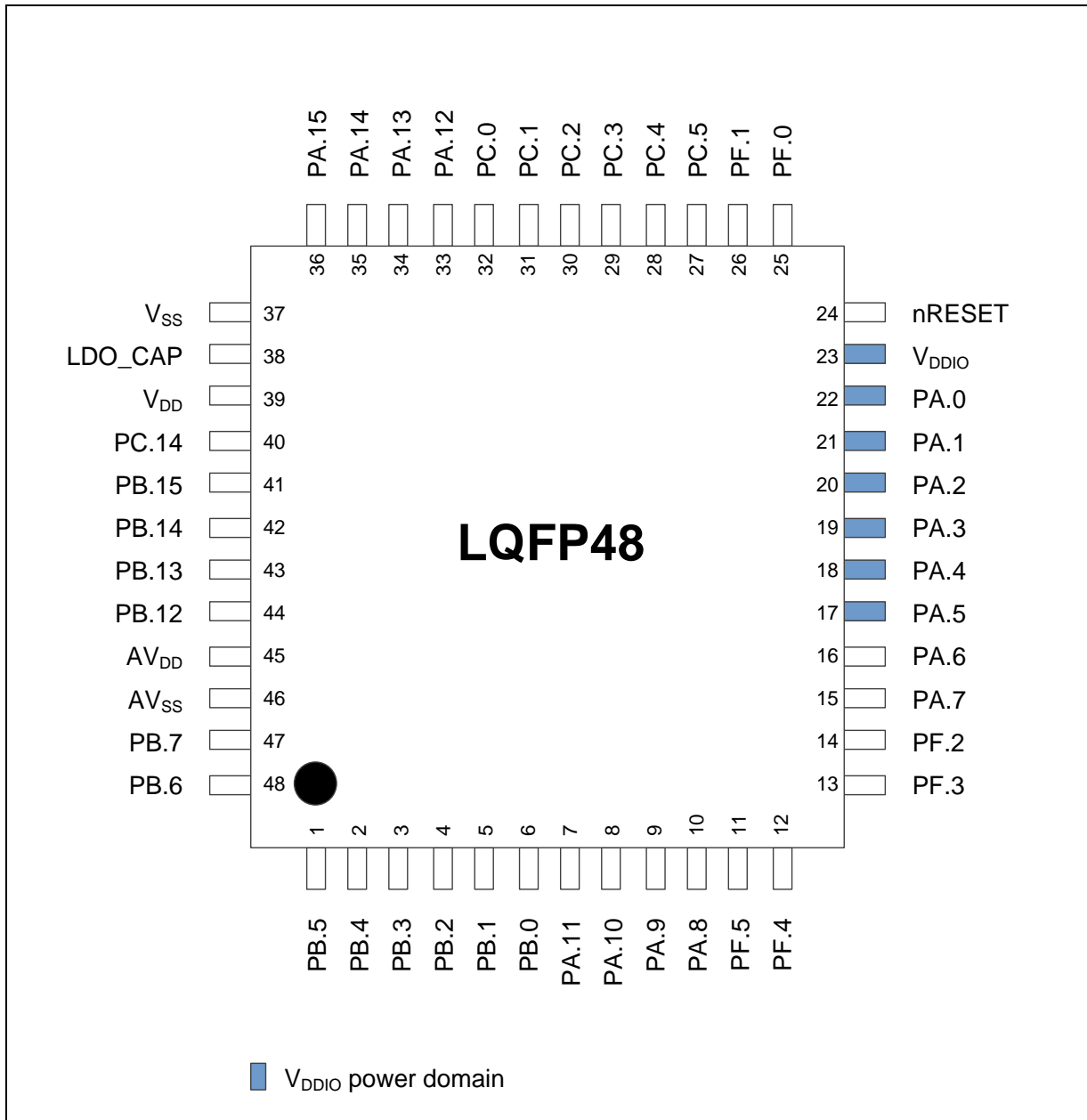

Figure 4.1-14 NuMicro[®] M485 Crypto Series LQFP 48-pin Diagram

4.1.15 NuMicro[®] M485 Crypto Series LQFP64 Pin Diagram

Corresponding Part Number: M485SIDAE

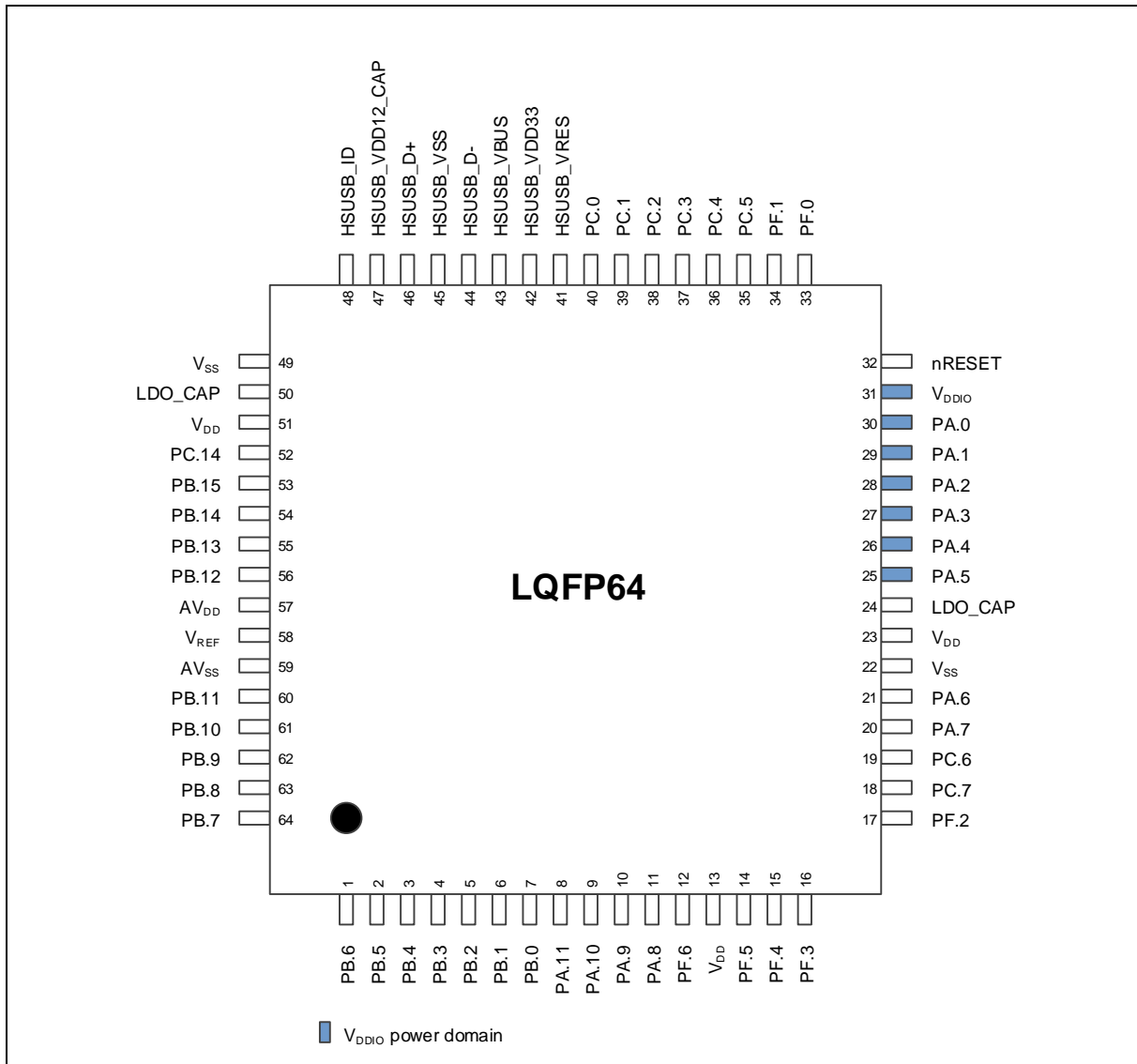

Figure 4.1-15 NuMicro[®] M485 Crypto Series LQFP 64-pin Diagram

4.1.16 NuMicro[®] M485 Crypto Series LQFP128 Pin Diagram

Corresponding Part Number: M485KIDAE

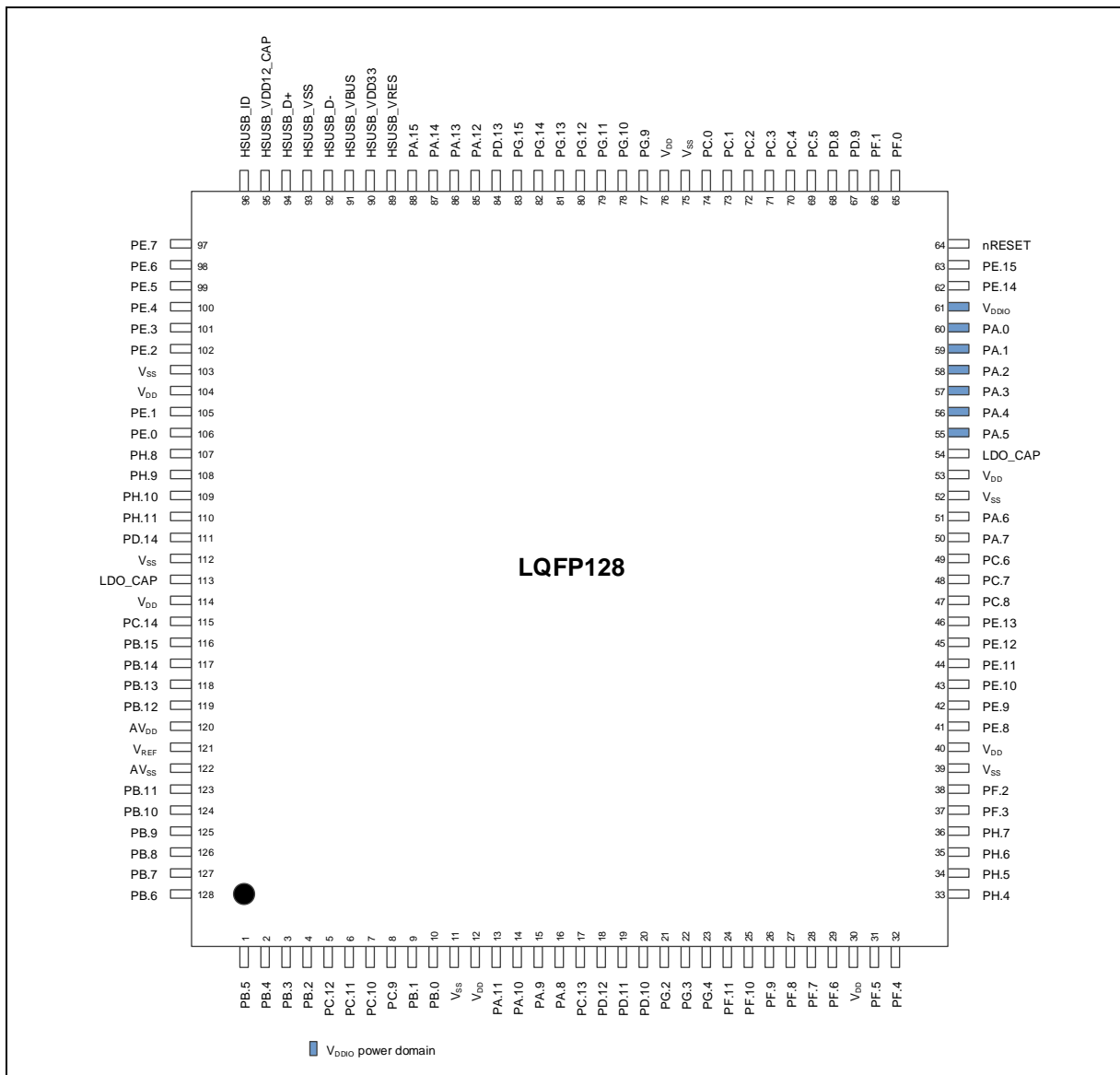

Figure 4.1-16 NuMicro[®] M485 Crypto Series LQFP 128-pin Diagram

4.1.17 NuMicro[®] M487 Ethernet Series LQFP64 Pin Diagram

Corresponding Part Number: M487SIDAE

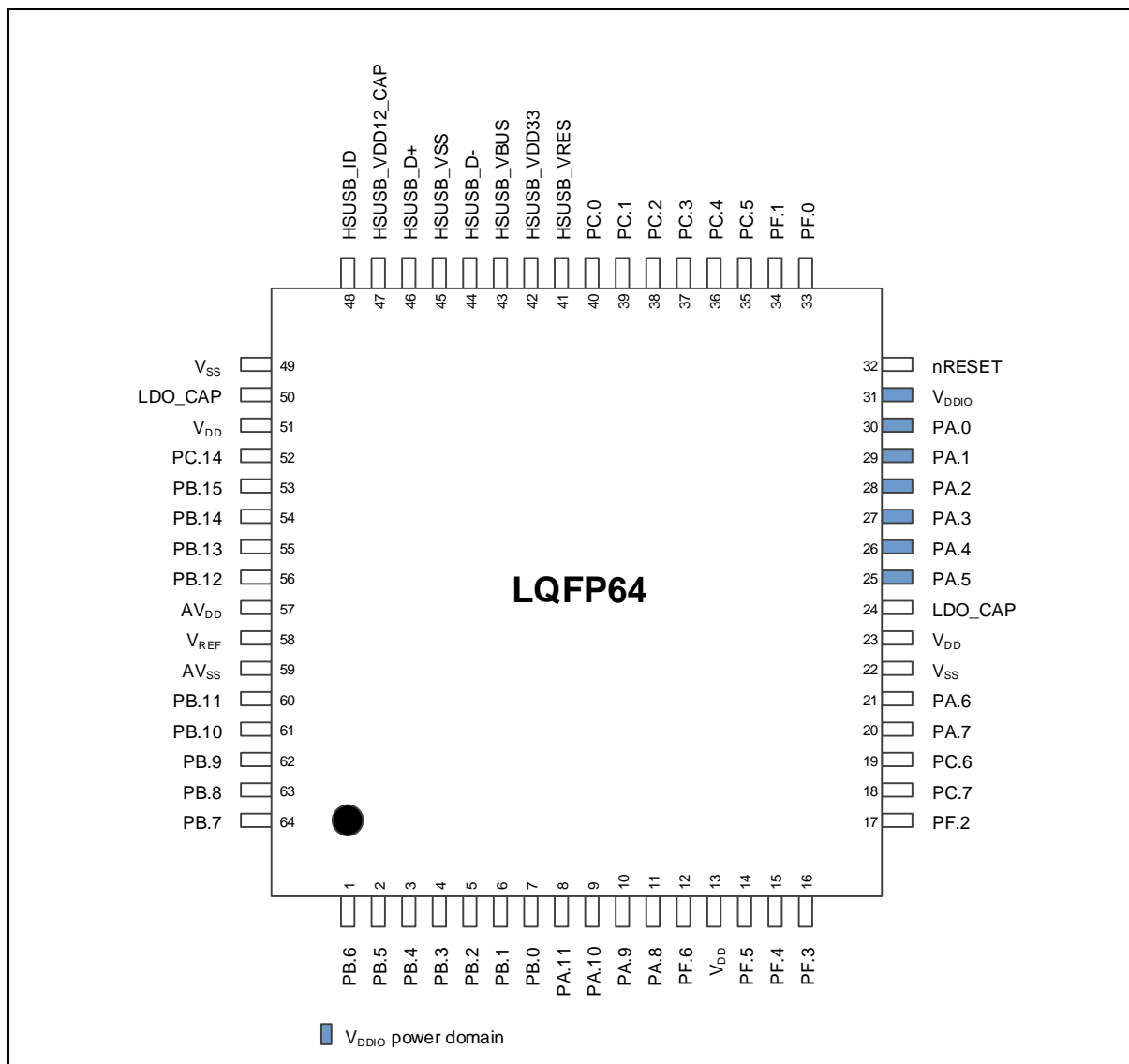

Figure 4.1-17 NuMicro[®] M487 Ethernet Series LQFP 64-pin Diagram

4.1.18 NuMicro[®] M487 Ethernet Series LQFP128 Pin Diagram

Corresponding Part Number: M487KIDAE

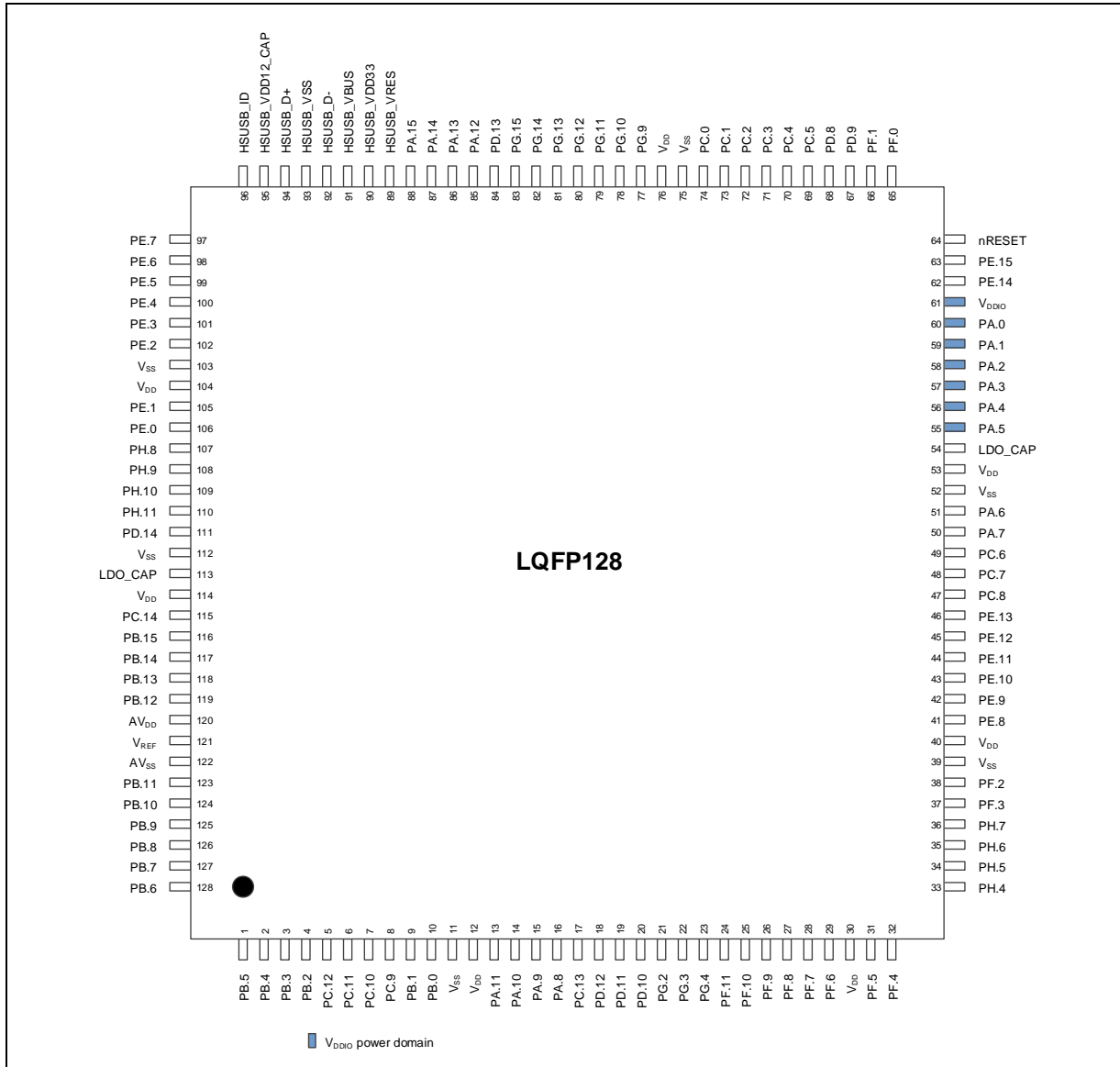

Figure 4.1-18 NuMicro[®] M487 Ethernet Series LQFP 128-pin Diagram

4.1.19 NuMicro[®] M487 Ethernet Series LQFP144 Pin Diagram

Corresponding Part Number: M487JIDAE

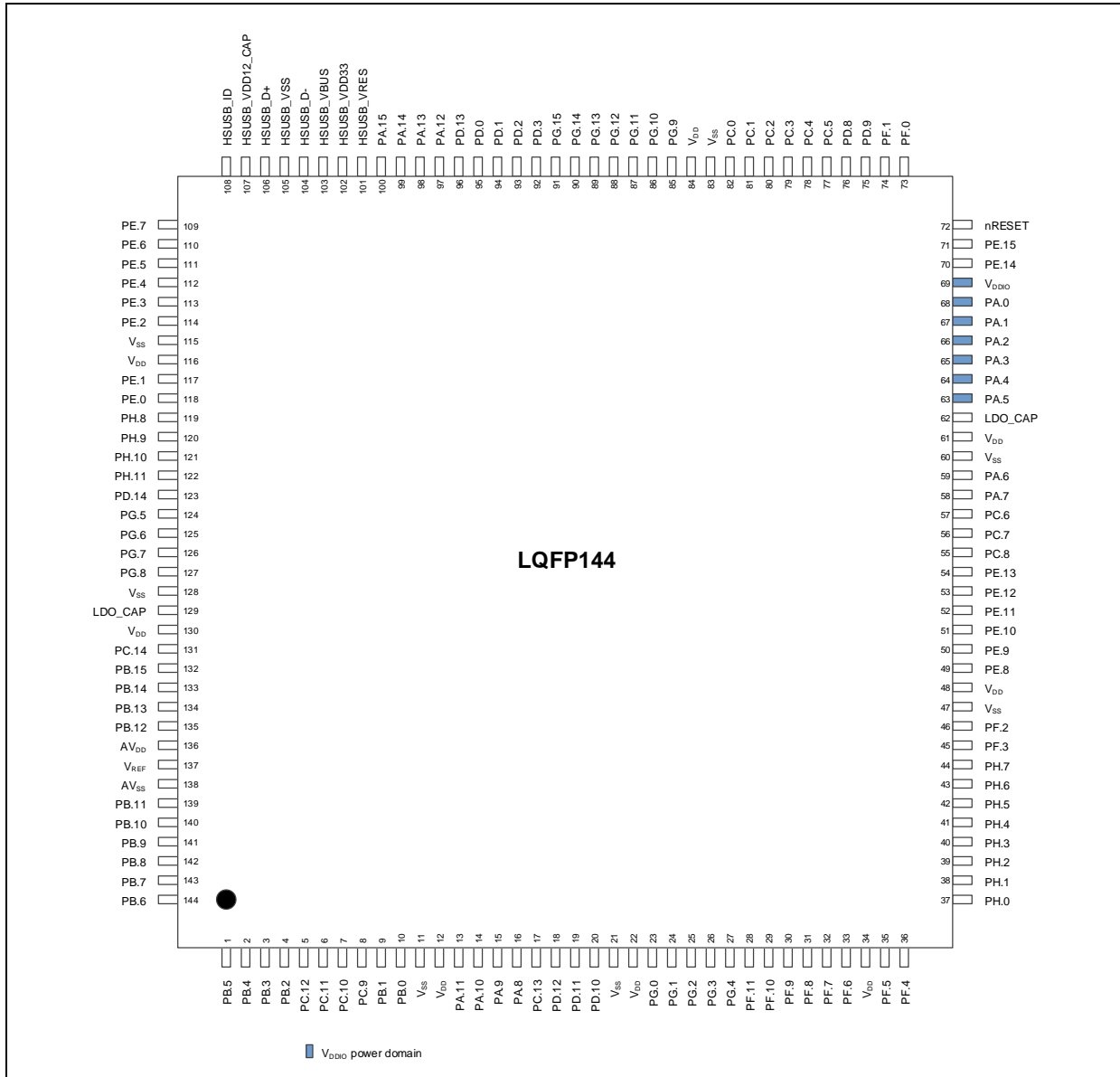

Figure 4.1-19 NuMicro[®] M487 Ethernet Series LQFP 144-pin Diagram

4.2 Pin Description

4.2.1 M481 Series Pin Description

MFP* = Multi-function pin. (Refer to section SYS_GP_x_MFPL and SYS_GP_x_MFPH)

PA.0 MFP0 means SYS_GPA_MFPL[3:0] = 0x0.

PA.9 MFP5 means SYS_GPA_MFPH[7:4] = 0x5.

32 Pin	48 Pin	64 Pin	Pin Name	Type	MFP	Description
	48	1	PB.6	I/O	MFP0	General purpose digital I/O pin.
			EADC0_CH6	A	MFP1	EADC0 channel 6 analog input.
			EBI_nWRH	O	MFP2	EBI high byte write enable output pin
			USCI1_DAT1	I/O	MFP4	USCI1 data 1 pin.
			UART1_RXD	I	MFP6	UART1 data receiver input pin.
			SD1_CLK	O	MFP7	SD/SDIO1 clock output pin
			EBI_nCS1	O	MFP8	EBI chip select 1 output pin.
			BPWM1_CH5	I/O	MFP10	BPWM1 channel 5 output/capture input.
			EPWM1_BRAKE1	I	MFP11	EPWM1 Brake 1 input pin.
			EPWM1_CH5	I/O	MFP12	EPWM1 channel 5 output/capture input.
			INT4	I	MFP13	External interrupt 4 input pin.
			ACMP1_O	O	MFP15	Analog comparator 1 output pin.
1	1	2	PB.5	I/O	MFP0	General purpose digital I/O pin.
			EADC0_CH5	A	MFP1	EADC0 channel 5 analog input.
			ACMP1_N	A	MFP1	Analog comparator 1 negative input pin.
			EBI_ADR0	O	MFP2	EBI address bus bit 0.
			SD0_DAT3	I/O	MFP3	SD/SDIO0 data line bit 3.
			SPI1_MISO	I/O	MFP5	SPI1 MISO (Master In, Slave Out) pin.
			I2C0_SCL	I/O	MFP6	I2C0 clock pin.
			UART5_TXD	O	MFP7	UART5 data transmitter output pin.
			USCI1_CTL0	I/O	MFP8	USCI1 control 0 pin.
			SC0_CLK	O	MFP9	Smart Card 0 clock pin.
			I2S0_BCLK	O	MFP10	I2S0 bit clock output pin.
			EPWM0_CH0	I/O	MFP11	EPWM0 channel 0 output/capture input.
			TM0	I/O	MFP14	Timer0 event counter input/toggle output pin.
			INT0	I	MFP15	External interrupt 0 input pin.
2	2	3	PB.4	I/O	MFP0	General purpose digital I/O pin.

32 Pin	48 Pin	64 Pin	Pin Name	Type	MFP	Description
			EADC0_CH4	A	MFP1	EADC0 channel 4 analog input.
			ACMP1_P1	A	MFP1	Analog comparator 1 positive input 1 pin.
			EBI_ADR1	O	MFP2	EBI address bus bit 1.
			SD0_DAT2	I/O	MFP3	SD/SDIO0 data line bit 2.
			SPI1_MOSI	I/O	MFP5	SPI1 MOSI (Master Out, Slave In) pin.
			I2C0_SDA	I/O	MFP6	I2C0 data input/output pin.
			UART5_RXD	I	MFP7	UART5 data receiver input pin.
			USCI1_CTL1	I/O	MFP8	USCI1 control 1 pin.
			SC0_DAT	I/O	MFP9	Smart Card 0 data pin.
			I2S0_MCLK	O	MFP10	I2S0 master clock output pin.
			EPWM0_CH1	I/O	MFP11	EPWM0 channel 1 output/capture input.
			TM1	I/O	MFP14	Timer1 event counter input/toggle output pin.
			INT1	I	MFP15	External interrupt 1 input pin.
3	3	4	PB.3	I/O	MFP0	General purpose digital I/O pin.
			EADC0_CH3	A	MFP1	EADC0 channel 3 analog input.
			ACMP0_N	A	MFP1	Analog comparator 0 negative input pin.
			EBI_ADR2	O	MFP2	EBI address bus bit 2.
			SD0_DAT1	I/O	MFP3	SD/SDIO0 data line bit 1.
			SPI1_CLK	I/O	MFP5	SPI1 serial clock pin.
			UART1_TXD	O	MFP6	UART1 data transmitter output pin.
			UART5_nRTS	O	MFP7	UART5 request to Send output pin.
			USCI1_DAT1	I/O	MFP8	USCI1 data 1 pin.
			SC0_RST	O	MFP9	Smart Card 0 reset pin.
			I2S0_DI	I	MFP10	I2S0 data input pin.
			EPWM0_CH2	I/O	MFP11	EPWM0 channel 2 output/capture input.
			TM2	I/O	MFP14	Timer2 event counter input/toggle output pin.
			INT2	I	MFP15	External interrupt 2 input pin.
4	4	5	PB.2	I/O	MFP0	General purpose digital I/O pin.
			EADC0_CH2	A	MFP1	EADC0 channel 2 analog input.
			ACMP0_P1	A	MFP1	Analog comparator 0 positive input 1 pin.
			OPA0_O	A	MFP1	Operational amplifier 0 output pin.
			EBI_ADR3	O	MFP2	EBI address bus bit 3.
			SD0_DAT0	I/O	MFP3	SD/SDIO0 data line bit 0.

32 Pin	48 Pin	64 Pin	Pin Name	Type	MFP	Description
			SPI1_SS	I/O	MFP5	SPI1 slave select pin.
			UART1_RXD	I	MFP6	UART1 data receiver input pin.
			UART5_nCTS	I	MFP7	UART5 clear to Send input pin.
			USCI1_DAT0	I/O	MFP8	USCI1 data 0 pin.
			SC0_PWR	O	MFP9	Smart Card 0 power pin.
			I2S0_DO	O	MFP10	I2S0 data output pin.
			EPWM0_CH3	I/O	MFP11	EPWM0 channel 3 output/capture input.
			TM3	I/O	MFP14	Timer3 event counter input/toggle output pin.
			INT3	I	MFP15	External interrupt 3 input pin.
5	5	6	PB.1	I/O	MFP0	General purpose digital I/O pin.
			EADC0_CH1	A	MFP1	EADC0 channel 1 analog input.
			OPA0_N	A	MFP1	Operational amplifier 0 negative input pin.
			EBI_ADR8	O	MFP2	EBI address bus bit 8.
			SD0_CLK	O	MFP3	SD/SDIO0 clock output pin
			SPI1_I2SMCLK	I/O	MFP5	SPI1 I2S master clock output pin
			SPI3_I2SMCLK	I/O	MFP6	SPI3 I2S master clock output pin
			UART2_TXD	O	MFP7	UART2 data transmitter output pin.
			USCI1_CLK	I/O	MFP8	USCI1 clock pin.
			I2C1_SCL	I/O	MFP9	I2C1 clock pin.
			I2S0_LRCK	O	MFP10	I2S0 left right channel clock output pin.
			EPWM0_CH4	I/O	MFP11	EPWM0 channel 4 output/capture input.
			EPWM1_CH4	I/O	MFP12	EPWM1 channel 4 output/capture input.
			EPWM0_BRAKE0	I	MFP13	EPWM0 Brake 0 input pin.
6	6	7	PB.0	I/O	MFP0	General purpose digital I/O pin.
			EADC0_CH0	A	MFP1	EADC0 channel 0 analog input.
			OPA0_P	A	MFP1	Operational amplifier 0 positive input pin.
			EBI_ADR9	O	MFP2	EBI address bus bit 9.
			SD0_CMD	I/O	MFP3	SD/SDIO0 command/response pin
			UART2_RXD	I	MFP7	UART2 data receiver input pin.
			SPI0_I2SMCLK	I/O	MFP8	SPI0 I2S master clock output pin
			I2C1_SDA	I/O	MFP9	I2C1 data input/output pin.
			EPWM0_CH5	I/O	MFP11	EPWM0 channel 5 output/capture input.
			EPWM1_CH5	I/O	MFP12	EPWM1 channel 5 output/capture input.

32 Pin	48 Pin	64 Pin	Pin Name	Type	MFP	Description
			EPWM0_BRAKE1	I	MFP13	EPWM0 Brake 1 input pin.
	7	8	PA.11	I/O	MFP0	General purpose digital I/O pin.
			ACMP0_P0	A	MFP1	Analog comparator 0 positive input 0 pin.
			EBI_nRD	O	MFP2	EBI read enable output pin.
			SC2_PWR	O	MFP3	Smart Card 2 power pin.
			SPI2_SS	I/O	MFP4	SPI2 slave select pin.
			SD1_DAT3	I/O	MFP5	SD/SDIO1 data line bit 3.
			USCI0_CLK	I/O	MFP6	USCI0 clock pin.
			I2C2_SCL	I/O	MFP7	I2C2 clock pin.
			BPWM0_CH0	I/O	MFP9	BPWM0 channel 0 output/capture input.
			EPWM0_SYNC_OUT	O	MFP10	EPWM0 counter synchronous trigger output pin.
			TM0_EXT	I/O	MFP13	Timer0 external capture input/toggle output pin.
			DAC1_ST	I	MFP14	DAC1 external trigger input.
	8	9	PA.10	I/O	MFP0	General purpose digital I/O pin.
			ACMP1_P0	A	MFP1	Analog comparator 1 positive input 0 pin.
			OPA1_O	A	MFP1	Operational amplifier 1 output pin.
			EBI_nWR	O	MFP2	EBI write enable output pin.
			SC2_RST	O	MFP3	Smart Card 2 reset pin.
			SPI2_CLK	I/O	MFP4	SPI2 serial clock pin.
			SD1_DAT2	I/O	MFP5	SD/SDIO1 data line bit 2.
			USCI0_DAT0	I/O	MFP6	USCI0 data 0 pin.
			I2C2_SDA	I/O	MFP7	I2C2 data input/output pin.
			BPWM0_CH1	I/O	MFP9	BPWM0 channel 1 output/capture input.
			QE11_INDEX	I	MFP10	Quadrature encoder 1 index input
			ECAP0_IC0	I	MFP11	Enhanced capture unit 0 input 0 pin.
			TM1_EXT	I/O	MFP13	Timer1 external capture input/toggle output pin.
			DAC0_ST	I	MFP14	DAC0 external trigger input.
	9	10	PA.9	I/O	MFP0	General purpose digital I/O pin.
			OPA1_N	A	MFP1	Operational amplifier 1 negative input pin.
			EBI_MCLK	O	MFP2	EBI external clock output pin.
			SC2_DAT	I/O	MFP3	Smart Card 2 data pin.
			SPI2_MISO	I/O	MFP4	SPI2 MISO (Master In, Slave Out) pin.
			SD1_DAT1	I/O	MFP5	SD/SDIO1 data line bit 1.

32 Pin	48 Pin	64 Pin	Pin Name	Type	MFP	Description
			USCI0_DAT1	I/O	MFP6	USCI0 data 1 pin.
			UART1_TXD	O	MFP7	UART1 data transmitter output pin.
			BPWM0_CH2	I/O	MFP9	BPWM0 channel 2 output/capture input.
			QE11_A	I	MFP10	Quadrature encoder 1 phase A input
			ECAP0_IC1	I	MFP11	Enhanced capture unit 0 input 1 pin.
			TM2_EXT	I/O	MFP13	Timer2 external capture input/toggle output pin.
	10	11	PA.8	I/O	MFP0	General purpose digital I/O pin.
			OPA1_P	A	MFP1	Operational amplifier 1 positive input pin.
			EBI_ALE	O	MFP2	EBI address latch enable output pin.
			SC2_CLK	O	MFP3	Smart Card 2 clock pin.
			SPI2_MOSI	I/O	MFP4	SPI2 MOSI (Master Out, Slave In) pin.
			SD1_DAT0	I/O	MFP5	SD/SDIO1 data line bit 0.
			USCI0_CTL1	I/O	MFP6	USCI0 control 1 pin.
			UART1_RXD	I	MFP7	UART1 data receiver input pin.
			BPWM0_CH3	I/O	MFP9	BPWM0 channel 3 output/capture input.
			QE11_B	I	MFP10	Quadrature encoder 1 phase B input
			ECAP0_IC2	I	MFP11	Enhanced capture unit 0 input 2 pin.
			TM3_EXT	I/O	MFP13	Timer3 external capture input/toggle output pin.
			INT4	I	MFP15	External interrupt 4 input pin.
		12	PF.6	I/O	MFP0	General purpose digital I/O pin.
			EBI_ADR19	O	MFP2	EBI address bus bit 19.
			SC0_CLK	O	MFP3	Smart Card 0 clock pin.
			I2S0_LRCK	O	MFP4	I2S0 left right channel clock output pin.
			SPI0_MOSI	I/O	MFP5	SPI0 MOSI (Master Out, Slave In) pin.
			UART4_RXD	I	MFP6	UART4 data receiver input pin.
			EBI_nCS0	O	MFP7	EBI chip select 0 output pin.
			TAMPER0	I/O	MFP10	TAMPER detector loop pin 0.
		13	V _{DD}	P	MFP0	Power supply for I/O ports and LDO source for internal PLL and digital circuit.
7	11	14	PF.5	I/O	MFP0	General purpose digital I/O pin.
			UART2_RXD	I	MFP2	UART2 data receiver input pin.
			UART2_nCTS	I	MFP4	UART2 clear to Send input pin.
			BPWM0_CH4	I/O	MFP8	BPWM0 channel 4 output/capture input.
			EPWM0_SYNC_OUT	O	MFP9	EPWM0 counter synchronous trigger output pin.

32 Pin	48 Pin	64 Pin	Pin Name	Type	MFP	Description
			X32_IN	I	MFP10	External 32.768 kHz crystal input pin.
			EADC0_ST	I	MFP11	EADC0 external trigger input.
8	12	15	PF.4	I/O	MFP0	General purpose digital I/O pin.
			UART2_TXD	O	MFP2	UART2 data transmitter output pin.
			UART2_nRTS	O	MFP4	UART2 request to Send output pin.
			BPWM0_CH5	I/O	MFP8	BPWM0 channel 5 output/capture input.
			X32_OUT	O	MFP10	External 32.768 kHz crystal output pin.
9	13	16	PF.3	I/O	MFP0	General purpose digital I/O pin.
			EBI_nCS0	O	MFP2	EBI chip select 0 output pin.
			UART0_TXD	O	MFP3	UART0 data transmitter output pin.
			I2C0_SCL	I/O	MFP4	I2C0 clock pin.
			XT1_IN	I	MFP10	External 4~24 MHz (high speed) crystal input pin.
			BPWM1_CH0	I/O	MFP11	BPWM1 channel 0 output/capture input.
10	14	17	PF.2	I/O	MFP0	General purpose digital I/O pin.
			EBI_nCS1	O	MFP2	EBI chip select 1 output pin.
			UART0_RXD	I	MFP3	UART0 data receiver input pin.
			I2C0_SDA	I/O	MFP4	I2C0 data input/output pin.
			QSPIO_CLK	I/O	MFP5	Quad SPI0 serial clock pin.
			XT1_OUT	O	MFP10	External 4~24 MHz (high speed) crystal output pin.
			BPWM1_CH1	I/O	MFP11	BPWM1 channel 1 output/capture input.
		18	PC.7	I/O	MFP0	General purpose digital I/O pin.
			EBI_AD9	I/O	MFP2	EBI address/data bus bit 9.
			SPI1_MISO	I/O	MFP4	SPI1 MISO (Master In, Slave Out) pin.
			UART4_TXD	O	MFP5	UART4 data transmitter output pin.
			SC2_PWR	O	MFP6	Smart Card 2 power pin.
			UART0_nCTS	I	MFP7	UART0 clear to Send input pin.
			I2C1_SMBAL	O	MFP8	I2C1 SMBus SMBALTER pin
			EPWM1_CH2	I/O	MFP11	EPWM1 channel 2 output/capture input.
			BPWM1_CH0	I/O	MFP12	BPWM1 channel 0 output/capture input.
			TM0	I/O	MFP14	Timer0 event counter input/toggle output pin.
			INT3	I	MFP15	External interrupt 3 input pin.
		19	PC.6	I/O	MFP0	General purpose digital I/O pin.
			EBI_AD8	I/O	MFP2	EBI address/data bus bit 8.

32 Pin	48 Pin	64 Pin	Pin Name	Type	MFP	Description
			SPI1_MOSI	I/O	MFP4	SPI1 MOSI (Master Out, Slave In) pin.
			UART4_RXD	I	MFP5	UART4 data receiver input pin.
			SC2_RST	O	MFP6	Smart Card 2 reset pin.
			UART0_nRTS	O	MFP7	UART0 request to Send output pin.
			I2C1_SMBSUS	O	MFP8	I2C1 SMBus SMBSUS pin (PMBus CONTROL pin)
			EPWM1_CH3	I/O	MFP11	EPWM1 channel 3 output/capture input.
			BPWM1_CH1	I/O	MFP12	BPWM1 channel 1 output/capture input.
			TM1	I/O	MFP14	Timer1 event counter input/toggle output pin.
			INT2	I	MFP15	External interrupt 2 input pin.
	15	20	PA.7	I/O	MFP0	General purpose digital I/O pin.
			EBI_AD7	I/O	MFP2	EBI address/data bus bit 7.
			SPI1_CLK	I/O	MFP4	SPI1 serial clock pin.
			SC2_DAT	I/O	MFP6	Smart Card 2 data pin.
			UART0_TXD	O	MFP7	UART0 data transmitter output pin.
			I2C1_SCL	I/O	MFP8	I2C1 clock pin.
			EPWM1_CH4	I/O	MFP11	EPWM1 channel 4 output/capture input.
			BPWM1_CH2	I/O	MFP12	BPWM1 channel 2 output/capture input.
			ACMP0_WLAT	I	MFP13	Analog comparator 0 window latch input pin
			TM2	I/O	MFP14	Timer2 event counter input/toggle output pin.
			INT1	I	MFP15	External interrupt 1 input pin.
	16	21	PA.6	I/O	MFP0	General purpose digital I/O pin.
			EBI_AD6	I/O	MFP2	EBI address/data bus bit 6.
			SPI1_SS	I/O	MFP4	SPI1 slave select pin.
			SD1_nCD	I	MFP5	SD/SDIO1 card detect input pin
			SC2_CLK	O	MFP6	Smart Card 2 clock pin.
			UART0_RXD	I	MFP7	UART0 data receiver input pin.
			I2C1_SDA	I/O	MFP8	I2C1 data input/output pin.
			EPWM1_CH5	I/O	MFP11	EPWM1 channel 5 output/capture input.
			BPWM1_CH3	I/O	MFP12	BPWM1 channel 3 output/capture input.
			ACMP1_WLAT	I	MFP13	Analog comparator 1 window latch input pin
			TM3	I/O	MFP14	Timer3 event counter input/toggle output pin.
			INT0	I	MFP15	External interrupt 0 input pin.
		22	VSS	P	MFP0	Ground pin for digital circuit.

32 Pin	48 Pin	64 Pin	Pin Name	Type	MFP	Description
		23	V _{DD}	P	MFP0	Power supply for I/O ports and LDO source for internal PLL and digital circuit.
		24	LDO_CAP	A	MFP0	LDO output pin.
	17	25	PA.5	I/O	MFP0	General purpose digital I/O pin.
			SPIM_D2	I/O	MFP2	SPIM data 2 pin for Quad Mode I/O.
			QSPI0_MISO1	I/O	MFP3	Quad SPI0 MISO1 (Master In, Slave Out) pin.
			SPI1_I2SMCLK	I/O	MFP4	SPI1 I2S master clock output pin
			SD1_CMD	I/O	MFP5	SD/SDIO1 command/response pin
			SC2_nCD	I	MFP6	Smart Card 2 card detect pin.
			UART0_nCTS	I	MFP7	UART0 clear to Send input pin.
			UART5_TXD	O	MFP8	UART5 data transmitter output pin.
			I2C0_SCL	I/O	MFP9	I2C0 clock pin.
			BPWM0_CH5	I/O	MFP12	BPWM0 channel 5 output/capture input.
			EPWM0_CH0	I/O	MFP13	EPWM0 channel 0 output/capture input.
			QEIO_INDEX	I	MFP14	Quadrature encoder 0 index input
	18	26	PA.4	I/O	MFP0	General purpose digital I/O pin.
			SPIM_D3	I/O	MFP2	SPIM data 3 pin for Quad Mode I/O.
			QSPI0_MOSI1	I/O	MFP3	Quad SPI0 MOSI1 (Master Out, Slave In) pin.
			SPI0_I2SMCLK	I/O	MFP4	SPI0 I2S master clock output pin
			SD1_CLK	O	MFP5	SD/SDIO1 clock output pin
			SC0_nCD	I	MFP6	Smart Card 0 card detect pin.
			UART0_nRTS	O	MFP7	UART0 request to Send output pin.
			UART5_RXD	I	MFP8	UART5 data receiver input pin.
			I2C0_SDA	I/O	MFP9	I2C0 data input/output pin.
			BPWM0_CH4	I/O	MFP12	BPWM0 channel 4 output/capture input.
			EPWM0_CH1	I/O	MFP13	EPWM0 channel 1 output/capture input.
			QEIO_A	I	MFP14	Quadrature encoder 0 phase A input
11	19	27	PA.3	I/O	MFP0	General purpose digital I/O pin.
			SPIM_SS	I/O	MFP2	SPIM slave select pin.
			QSPI0_SS	I/O	MFP3	Quad SPI0 slave select pin.
			SPI0_SS	I/O	MFP4	SPI0 slave select pin.
			SD1_DAT3	I/O	MFP5	SD/SDIO1 data line bit 3.
			SC0_PWR	O	MFP6	Smart Card 0 power pin.
			UART4_TXD	O	MFP7	UART4 data transmitter output pin.

32 Pin	48 Pin	64 Pin	Pin Name	Type	MFP	Description
			UART1_TXD	O	MFP8	UART1 data transmitter output pin.
			I2C1_SCL	I/O	MFP9	I2C1 clock pin.
			BPWM0_CH3	I/O	MFP12	BPWM0 channel 3 output/capture input.
			EPWM0_CH2	I/O	MFP13	EPWM0 channel 2 output/capture input.
			QEIO_B	I	MFP14	Quadrature encoder 0 phase B input
12	20	28	PA.2	I/O	MFP0	General purpose digital I/O pin.
			SPIM_CLK	I/O	MFP2	SPIM serial clock pin.
			QSPIO_CLK	I/O	MFP3	Quad SPI0 serial clock pin.
			SPIO_CLK	I/O	MFP4	SPIO serial clock pin.
			SD1_DAT2	I/O	MFP5	SD/SDIO1 data line bit 2.
			SC0_RST	O	MFP6	Smart Card 0 reset pin.
			UART4_RXD	I	MFP7	UART4 data receiver input pin.
			UART1_RXD	I	MFP8	UART1 data receiver input pin.
			I2C1_SDA	I/O	MFP9	I2C1 data input/output pin.
			BPWM0_CH2	I/O	MFP12	BPWM0 channel 2 output/capture input.
			EPWM0_CH3	I/O	MFP13	EPWM0 channel 3 output/capture input.
13	21	29	PA.1	I/O	MFP0	General purpose digital I/O pin.
			SPIM_MISO	I/O	MFP2	SPIM MISO (Master In, Slave Out) pin.
			QSPIO_MISO0	I/O	MFP3	Quad SPI0 MISO0 (Master In, Slave Out) pin.
			SPIO_MISO	I/O	MFP4	SPIO MISO (Master In, Slave Out) pin.
			SD1_DAT1	I/O	MFP5	SD/SDIO1 data line bit 1.
			SC0_DAT	I/O	MFP6	Smart Card 0 data pin.
			UART0_TXD	O	MFP7	UART0 data transmitter output pin.
			UART1_nCTS	I	MFP8	UART1 clear to Send input pin.
			I2C2_SCL	I/O	MFP9	I2C2 clock pin.
			BPWM0_CH1	I/O	MFP12	BPWM0 channel 1 output/capture input.
			EPWM0_CH4	I/O	MFP13	EPWM0 channel 4 output/capture input.
			DAC1_ST	I	MFP15	DAC1 external trigger input.
14	22	30	PA.0	I/O	MFP0	General purpose digital I/O pin.
			SPIM_MOSI	I/O	MFP2	SPIM MOSI (Master Out, Slave In) pin.
			QSPIO_MOSI0	I/O	MFP3	Quad SPI0 MOSI0 (Master Out, Slave In) pin.
			SPIO_MOSI	I/O	MFP4	SPIO MOSI (Master Out, Slave In) pin.
			SD1_DAT0	I/O	MFP5	SD/SDIO1 data line bit 0.

32 Pin	48 Pin	64 Pin	Pin Name	Type	MFP	Description
			SC0_CLK	O	MFP6	Smart Card 0 clock pin.
			UART0_RXD	I	MFP7	UART0 data receiver input pin.
			UART1_nRTS	O	MFP8	UART1 request to Send output pin.
			I2C2_SDA	I/O	MFP9	I2C2 data input/output pin.
			BPWM0_CH0	I/O	MFP12	BPWM0 channel 0 output/capture input.
			EPWM0_CH5	I/O	MFP13	EPWM0 channel 5 output/capture input.
			DAC0_ST	I	MFP15	DAC0 external trigger input.
15	23	31	VDDIO	P	MFP0	Power supply for PA.0~PA.5.
16	24	32	nRESET	I	MFP0	External reset input: active LOW, with an internal pull-up. Set this pin low reset to initial state.
17	25	33	PF.0	I/O	MFP0	General purpose digital I/O pin.
			UART1_TXD	O	MFP2	UART1 data transmitter output pin.
			I2C1_SCL	I/O	MFP3	I2C1 clock pin.
			BPWM1_CH0	I/O	MFP12	BPWM1 channel 0 output/capture input.
			ICE_DAT	O	MFP14	Serial wired debugger data pin.
18	26	34	PF.1	I/O	MFP0	General purpose digital I/O pin.
			UART1_RXD	I	MFP2	UART1 data receiver input pin.
			I2C1_SDA	I/O	MFP3	I2C1 data input/output pin.
			BPWM1_CH1	I/O	MFP12	BPWM1 channel 1 output/capture input.
			ICE_CLK	I	MFP14	Serial wired debugger clock pin.
	27	35	PC.5	I/O	MFP0	General purpose digital I/O pin.
			EBI_AD5	I/O	MFP2	EBI address/data bus bit 5.
			SPIM_D2	I/O	MFP3	SPIM data 2 pin for Quad Mode I/O.
			QSPI0_MISO1	I/O	MFP4	Quad SPI0 MISO1 (Master In, Slave Out) pin.
			UART2_TXD	O	MFP8	UART2 data transmitter output pin.
			I2C1_SCL	I/O	MFP9	I2C1 clock pin.
			UART4_TXD	O	MFP11	UART4 data transmitter output pin.
			EPWM1_CH0	I/O	MFP12	EPWM1 channel 0 output/capture input.
	28	36	PC.4	I/O	MFP0	General purpose digital I/O pin.
			EBI_AD4	I/O	MFP2	EBI address/data bus bit 4.
			SPIM_D3	I/O	MFP3	SPIM data 3 pin for Quad Mode I/O.
			QSPI0_MOSI1	I/O	MFP4	Quad SPI0 MOSI1 (Master Out, Slave In) pin.
			SC1_nCD	I	MFP5	Smart Card 1 card detect pin.
			I2S0_BCLK	O	MFP6	I2S0 bit clock output pin.

32 Pin	48 Pin	64 Pin	Pin Name	Type	MFP	Description
			SPI1_I2SMCLK	I/O	MFP7	SPI1 I2S master clock output pin
			UART2_RXD	I	MFP8	UART2 data receiver input pin.
			I2C1_SDA	I/O	MFP9	I2C1 data input/output pin.
			UART4_RXD	I	MFP11	UART4 data receiver input pin.
			EPWM1_CH1	I/O	MFP12	EPWM1 channel 1 output/capture input.
	29	37	PC.3	I/O	MFP0	General purpose digital I/O pin.
			EBI_AD3	I/O	MFP2	EBI address/data bus bit 3.
			SPIM_SS	I/O	MFP3	SPIM slave select pin.
			QSPI0_SS	I/O	MFP4	Quad SPI0 slave select pin.
			SC1_PWR	O	MFP5	Smart Card 1 power pin.
			I2S0_MCLK	O	MFP6	I2S0 master clock output pin.
			SPI1_MISO	I/O	MFP7	SPI1 MISO (Master In, Slave Out) pin.
			UART2_nRTS	O	MFP8	UART2 request to Send output pin.
			I2C0_SMBAL	O	MFP9	I2C0 SMBus SMBALTER pin
			UART3_TXD	O	MFP11	UART3 data transmitter output pin.
			EPWM1_CH2	I/O	MFP12	EPWM1 channel 2 output/capture input.
	30	38	PC.2	I/O	MFP0	General purpose digital I/O pin.
			EBI_AD2	I/O	MFP2	EBI address/data bus bit 2.
			SPIM_CLK	I/O	MFP3	SPIM serial clock pin.
			QSPI0_CLK	I/O	MFP4	Quad SPI0 serial clock pin.
			SC1_RST	O	MFP5	Smart Card 1 reset pin.
			I2S0_DI	I	MFP6	I2S0 data input pin.
			SPI1_MOSI	I/O	MFP7	SPI1 MOSI (Master Out, Slave In) pin.
			UART2_nCTS	I	MFP8	UART2 clear to Send input pin.
			I2C0_SMBSUS	O	MFP9	I2C0 SMBus SMBSUS pin (PMBus CONTROL pin)
			UART3_RXD	I	MFP11	UART3 data receiver input pin.
			EPWM1_CH3	I/O	MFP12	EPWM1 channel 3 output/capture input.
19	31	39	PC.1	I/O	MFP0	General purpose digital I/O pin.
			EBI_AD1	I/O	MFP2	EBI address/data bus bit 1.
			SPIM_MISO	I/O	MFP3	SPIM MISO (Master In, Slave Out) pin.
			QSPI0_MISO0	I/O	MFP4	Quad SPI0 MISO0 (Master In, Slave Out) pin.
			SC1_DAT	I/O	MFP5	Smart Card 1 data pin.
			I2S0_DO	O	MFP6	I2S0 data output pin.

32 Pin	48 Pin	64 Pin	Pin Name	Type	MFP	Description
			SPI1_CLK	I/O	MFP7	SPI1 serial clock pin.
			UART2_TXD	O	MFP8	UART2 data transmitter output pin.
			I2C0_SCL	I/O	MFP9	I2C0 clock pin.
			EPWM1_CH4	I/O	MFP12	EPWM1 channel 4 output/capture input.
			ACMP0_O	O	MFP14	Analog comparator 0 output pin.
20	32	40	PC.0	I/O	MFP0	General purpose digital I/O pin.
			EBI_AD0	I/O	MFP2	EBI address/data bus bit 0.
			SPIM_MOSI	I/O	MFP3	SPIM MOSI (Master Out, Slave In) pin.
			QSPI0_MOSI0	I/O	MFP4	Quad SPI0 MOSI0 (Master Out, Slave In) pin.
			SC1_CLK	O	MFP5	Smart Card 1 clock pin.
			I2S0_LRCK	O	MFP6	I2S0 left right channel clock output pin.
			SPI1_SS	I/O	MFP7	SPI1 slave select pin.
			UART2_RXD	I	MFP8	UART2 data receiver input pin.
			I2C0_SDA	I/O	MFP9	I2C0 data input/output pin.
			EPWM1_CH5	I/O	MFP12	EPWM1 channel 5 output/capture input.
			ACMP1_O	O	MFP14	Analog comparator 1 output pin.
		41	PD.3	I/O	MFP0	General purpose digital I/O pin.
			EBI_AD10	I/O	MFP2	EBI address/data bus bit 10.
			USCI0_CTL1	I/O	MFP3	USCI0 control 1 pin.
			SPI0_SS	I/O	MFP4	SPI0 slave select pin.
			UART3_nRTS	O	MFP5	UART3 request to Send output pin.
			USCI1_CTL0	I/O	MFP6	USCI1 control 0 pin.
			SC2_PWR	O	MFP7	Smart Card 2 power pin.
			SC1_nCD	I	MFP8	Smart Card 1 card detect pin.
			UART0_TXD	O	MFP9	UART0 data transmitter output pin.
		42	PD.2	I/O	MFP0	General purpose digital I/O pin.
			EBI_AD11	I/O	MFP2	EBI address/data bus bit 11.
			USCI0_DAT1	I/O	MFP3	USCI0 data 1 pin.
			SPI0_CLK	I/O	MFP4	SPI0 serial clock pin.
			UART3_nCTS	I	MFP5	UART3 clear to Send input pin.
			SC2_RST	O	MFP7	Smart Card 2 reset pin.
			UART0_RXD	I	MFP9	UART0 data receiver input pin.
		43	PD.1	I/O	MFP0	General purpose digital I/O pin.

32 Pin	48 Pin	64 Pin	Pin Name	Type	MFP	Description
			EBI_AD12	I/O	MFP2	EBI address/data bus bit 12.
			USCI0_DAT0	I/O	MFP3	USCI0 data 0 pin.
			SPI0_MISO	I/O	MFP4	SPI0 MISO (Master In, Slave Out) pin.
			UART3_TXD	O	MFP5	UART3 data transmitter output pin.
			I2C2_SCL	I/O	MFP6	I2C2 clock pin.
			SC2_DAT	I/O	MFP7	Smart Card 2 data pin.
		44	PD.0	I/O	MFP0	General purpose digital I/O pin.
			EBI_AD13	I/O	MFP2	EBI address/data bus bit 13.
			USCI0_CLK	I/O	MFP3	USCI0 clock pin.
			SPI0_MOSI	I/O	MFP4	SPI0 MOSI (Master Out, Slave In) pin.
			UART3_RXD	I	MFP5	UART3 data receiver input pin.
			I2C2_SDA	I/O	MFP6	I2C2 data input/output pin.
			SC2_CLK	O	MFP7	Smart Card 2 clock pin.
			TM2	I/O	MFP14	Timer2 event counter input/toggle output pin.
21	33	45	PA.12	I/O	MFP0	General purpose digital I/O pin.
			I2S0_BCLK	O	MFP2	I2S0 bit clock output pin.
			UART4_TXD	O	MFP3	UART4 data transmitter output pin.
			I2C1_SCL	I/O	MFP4	I2C1 clock pin.
			SPI2_SS	I/O	MFP5	SPI2 slave select pin.
			SC2_PWR	O	MFP7	Smart Card 2 power pin.
			BPWM1_CH2	I/O	MFP11	BPWM1 channel 2 output/capture input.
			QE11_INDEX	I	MFP12	Quadrature encoder 1 index input
22	34	46	PA.13	I/O	MFP0	General purpose digital I/O pin.
			I2S0_MCLK	O	MFP2	I2S0 master clock output pin.
			UART4_RXD	I	MFP3	UART4 data receiver input pin.
			I2C1_SDA	I/O	MFP4	I2C1 data input/output pin.
			SPI2_CLK	I/O	MFP5	SPI2 serial clock pin.
			SC2_RST	O	MFP7	Smart Card 2 reset pin.
			BPWM1_CH3	I/O	MFP11	BPWM1 channel 3 output/capture input.
			QE11_A	I	MFP12	Quadrature encoder 1 phase A input
23	35	47	PA.14	I/O	MFP0	General purpose digital I/O pin.
			I2S0_DI	I	MFP2	I2S0 data input pin.
			UART0_TXD	O	MFP3	UART0 data transmitter output pin.

32 Pin	48 Pin	64 Pin	Pin Name	Type	MFP	Description
			SPI2_MISO	I/O	MFP5	SPI2 MISO (Master In, Slave Out) pin.
			I2C2_SCL	I/O	MFP6	I2C2 clock pin.
			SC2_DAT	I/O	MFP7	Smart Card 2 data pin.
			BPWM1_CH4	I/O	MFP11	BPWM1 channel 4 output/capture input.
			QE11_B	I	MFP12	Quadrature encoder 1 phase B input
24	36	48	PA.15	I/O	MFP0	General purpose digital I/O pin.
			I2S0_DO	O	MFP2	I2S0 data output pin.
			UART0_RXD	I	MFP3	UART0 data receiver input pin.
			SPI2_MOSI	I/O	MFP5	SPI2 MOSI (Master Out, Slave In) pin.
			I2C2_SDA	I/O	MFP6	I2C2 data input/output pin.
			SC2_CLK	O	MFP7	Smart Card 2 clock pin.
			BPWM1_CH5	I/O	MFP11	BPWM1 channel 5 output/capture input.
			EPWM0_SYNC_IN	I	MFP12	EPWM0 counter synchronous trigger input pin.
25	37	49	VSS	P	MFP0	Ground pin for digital circuit.
26	38	50	LDO_CAP	A	MFP0	LDO output pin.
27	39	51	V _{DD}	P	MFP0	Power supply for I/O ports and LDO source for internal PLL and digital circuit.
	40	52	PC.14	I/O	MFP0	General purpose digital I/O pin.
			EBI_AD11	I/O	MFP2	EBI address/data bus bit 11.
			SC1_nCD	I	MFP3	Smart Card 1 card detect pin.
			SPI0_I2SMCLK	I/O	MFP4	SPI0 I2S master clock output pin
			USCI0_CTL0	I/O	MFP5	USCI0 control 0 pin.
			QSPI0_CLK	I/O	MFP6	Quad SPI0 serial clock pin.
			EPWM0_SYNC_IN	I	MFP11	EPWM0 counter synchronous trigger input pin.
			TM1	I/O	MFP13	Timer1 event counter input/toggle output pin.
28	41	53	PB.15	I/O	MFP0	General purpose digital I/O pin.
			EADC0_CH15	A	MFP1	EADC0 channel 15 analog input.
			EBI_AD12	I/O	MFP2	EBI address/data bus bit 12.
			SC1_PWR	O	MFP3	Smart Card 1 power pin.
			SPI0_SS	I/O	MFP4	SPI0 slave select pin.
			USCI0_CTL1	I/O	MFP5	USCI0 control 1 pin.
			UART0_nCTS	I	MFP6	UART0 clear to Send input pin.
			UART3_TXD	O	MFP7	UART3 data transmitter output pin.
			I2C2_SMBAL	O	MFP8	I2C2 SMBus SMBALTER pin

32 Pin	48 Pin	64 Pin	Pin Name	Type	MFP	Description
			EPWM1_CH0	I/O	MFP11	EPWM1 channel 0 output/capture input.
			TM0_EXT	I/O	MFP13	Timer0 external capture input/toggle output pin.
29	42	54	PB.14	I/O	MFP0	General purpose digital I/O pin.
			EADC0_CH14	A	MFP1	EADC0 channel 14 analog input.
			EBI_AD13	I/O	MFP2	EBI address/data bus bit 13.
			SC1_RST	O	MFP3	Smart Card 1 reset pin.
			SPI0_CLK	I/O	MFP4	SPI0 serial clock pin.
			USCI0_DAT1	I/O	MFP5	USCI0 data 1 pin.
			UART0_nRTS	O	MFP6	UART0 request to Send output pin.
			UART3_RXD	I	MFP7	UART3 data receiver input pin.
			I2C2_SMBUS	O	MFP8	I2C2 SMBus SMBUS pin (PMBus CONTROL pin)
			EPWM1_CH1	I/O	MFP11	EPWM1 channel 1 output/capture input.
			TM1_EXT	I/O	MFP13	Timer1 external capture input/toggle output pin.
			CLKO	O	MFP14	Clock Out
30	43	55	PB.13	I/O	MFP0	General purpose digital I/O pin.
			EADC0_CH13	A	MFP1	EADC0 channel 13 analog input.
			DAC1_OUT	A	MFP1	DAC1 channel analog output.
			ACMP0_P3	A	MFP1	Analog comparator 0 positive input 3 pin.
			ACMP1_P3	A	MFP1	Analog comparator 1 positive input 3 pin.
			EBI_AD14	I/O	MFP2	EBI address/data bus bit 14.
			SC1_DAT	I/O	MFP3	Smart Card 1 data pin.
			SPI0_MISO	I/O	MFP4	SPI0 MISO (Master In, Slave Out) pin.
			USCI0_DAT0	I/O	MFP5	USCI0 data 0 pin.
			UART0_TXD	O	MFP6	UART0 data transmitter output pin.
			UART3_nRTS	O	MFP7	UART3 request to Send output pin.
			I2C2_SCL	I/O	MFP8	I2C2 clock pin.
			EPWM1_CH2	I/O	MFP11	EPWM1 channel 2 output/capture input.
			TM2_EXT	I/O	MFP13	Timer2 external capture input/toggle output pin.
31	44	56	PB.12	I/O	MFP0	General purpose digital I/O pin.
			EADC0_CH12	A	MFP1	EADC0 channel 12 analog input.
			DAC0_OUT	A	MFP1	DAC0 channel analog output.
			ACMP0_P2	A	MFP1	Analog comparator 0 positive input 2 pin.
			ACMP1_P2	A	MFP1	Analog comparator 1 positive input 2 pin.

32 Pin	48 Pin	64 Pin	Pin Name	Type	MFP	Description
			EBI_AD15	I/O	MFP2	EBI address/data bus bit 15.
			SC1_CLK	O	MFP3	Smart Card 1 clock pin.
			SPI0_MOSI	I/O	MFP4	SPI0 MOSI (Master Out, Slave In) pin.
			USCI0_CLK	I/O	MFP5	USCI0 clock pin.
			UART0_RXD	I	MFP6	UART0 data receiver input pin.
			UART3_nCTS	I	MFP7	UART3 clear to Send input pin.
			I2C2_SDA	I/O	MFP8	I2C2 data input/output pin.
			SD0_nCD	I	MFP9	SD/SDIO0 card detect input pin
			EPWM1_CH3	I/O	MFP11	EPWM1 channel 3 output/capture input.
			TM3_EXT	I/O	MFP13	Timer3 external capture input/toggle output pin.
32	45	57	AV _{DD}	P	MFP0	Power supply for internal analog circuit.
		58	V _{REF}	A	MFP0	ADC reference voltage input. Note: This pin needs to be connected with a 1uF capacitor.
	46	59	AVSS	P	MFP0	Ground pin for analog circuit.
		60	PB.11	I/O	MFP0	General purpose digital I/O pin.
			EADC0_CH11	A	MFP1	EADC0 channel 11 analog input.
			EBI_ADR16	O	MFP2	EBI address bus bit 16.
			UART0_nCTS	I	MFP5	UART0 clear to Send input pin.
			UART4_TXD	O	MFP6	UART4 data transmitter output pin.
			I2C1_SCL	I/O	MFP7	I2C1 clock pin.
			SPI0_I2SMCLK	I/O	MFP9	SPI0 I2S master clock output pin
			BPWM1_CH0	I/O	MFP10	BPWM1 channel 0 output/capture input.
			SPI3_CLK	I/O	MFP11	SPI3 serial clock pin.
		61	PB.10	I/O	MFP0	General purpose digital I/O pin.
			EADC0_CH10	A	MFP1	EADC0 channel 10 analog input.
			EBI_ADR17	O	MFP2	EBI address bus bit 17.
			USCI1_CTL0	I/O	MFP4	USCI1 control 0 pin.
			UART0_nRTS	O	MFP5	UART0 request to Send output pin.
			UART4_RXD	I	MFP6	UART4 data receiver input pin.
			I2C1_SDA	I/O	MFP7	I2C1 data input/output pin.
			BPWM1_CH1	I/O	MFP10	BPWM1 channel 1 output/capture input.
			SPI3_SS	I/O	MFP11	SPI3 slave select pin.
		62	PB.9	I/O	MFP0	General purpose digital I/O pin.

32 Pin	48 Pin	64 Pin	Pin Name	Type	MFP	Description
			EADC0_CH9	A	MFP1	EADC0 channel 9 analog input.
			EBI_ADR18	O	MFP2	EBI address bus bit 18.
			USCI1_CTL1	I/O	MFP4	USCI1 control 1 pin.
			UART0_TXD	O	MFP5	UART0 data transmitter output pin.
			UART1_nCTS	I	MFP6	UART1 clear to Send input pin.
			I2C1_SMBAL	O	MFP7	I2C1 SMBus SMBALTER pin
			BPWM1_CH2	I/O	MFP10	BPWM1 channel 2 output/capture input.
			SPI3_MISO	I/O	MFP11	SPI3 MISO (Master In, Slave Out) pin.
			INT7	I	MFP13	External interrupt 7 input pin.
		63	PB.8	I/O	MFP0	General purpose digital I/O pin.
			EADC0_CH8	A	MFP1	EADC0 channel 8 analog input.
			EBI_ADR19	O	MFP2	EBI address bus bit 19.
			USCI1_CLK	I/O	MFP4	USCI1 clock pin.
			UART0_RXD	I	MFP5	UART0 data receiver input pin.
			UART1_nRTS	O	MFP6	UART1 request to Send output pin.
			I2C1_SMBSUS	O	MFP7	I2C1 SMBus SMBSUS pin (PMBus CONTROL pin)
			BPWM1_CH3	I/O	MFP10	BPWM1 channel 3 output/capture input.
			SPI3_MOSI	I/O	MFP11	SPI3 MOSI (Master Out, Slave In) pin.
			INT6	I	MFP13	External interrupt 6 input pin.
	47	64	PB.7	I/O	MFP0	General purpose digital I/O pin.
			EADC0_CH7	A	MFP1	EADC0 channel 7 analog input.
			EBI_nWRL	O	MFP2	EBI low byte write enable output pin.
			USCI1_DAT0	I/O	MFP4	USCI1 data 0 pin.
			UART1_TXD	O	MFP6	UART1 data transmitter output pin.
			SD1_CMD	I/O	MFP7	SD/SDIO1 command/response pin
			EBI_nCS0	O	MFP8	EBI chip select 0 output pin.
			BPWM1_CH4	I/O	MFP10	BPWM1 channel 4 output/capture input.
			EPWM1_BRAKE0	I	MFP11	EPWM1 Brake 0 input pin.
			EPWM1_CH4	I/O	MFP12	EPWM1 channel 4 output/capture input.
			INT5	I	MFP13	External interrupt 5 input pin.
			ACMP0_O	O	MFP15	Analog comparator 0 output pin.

4.2.2 M482 Series Pin Description

32 Pin	48 Pin	64 Pin	128 Pin	Pin Name	Type	MFP	Description
1	1	2	1	PB.5	I/O	MFP0	General purpose digital I/O pin.
				EADC0_CH5	A	MFP1	EADC0 channel 5 analog input.
				ACMP1_N	A	MFP1	Analog comparator 1 negative input pin.
				EBI_ADR0	O	MFP2	EBI address bus bit 0.
				SD0_DAT3	I/O	MFP3	SD/SDIO0 data line bit 3.
				SPI1_MISO	I/O	MFP5	SPI1 MISO (Master In, Slave Out) pin.
				I2C0_SCL	I/O	MFP6	I2C0 clock pin.
				UART5_TXD	O	MFP7	UART5 data transmitter output pin.
				USCI1_CTL0	I/O	MFP8	USCI1 control 0 pin.
				SC0_CLK	O	MFP9	Smart Card 0 clock pin.
				I2S0_BCLK	O	MFP10	I2S0 bit clock output pin.
				EPWM0_CH0	I/O	MFP11	EPWM0 channel 0 output/capture input.
				TM0	I/O	MFP14	Timer0 event counter input/toggle output pin.
INT0	I	MFP15	External interrupt 0 input pin.				
2	2	3	2	PB.4	I/O	MFP0	General purpose digital I/O pin.
				EADC0_CH4	A	MFP1	EADC0 channel 4 analog input.
				ACMP1_P1	A	MFP1	Analog comparator 1 positive input 1 pin.
				EBI_ADR1	O	MFP2	EBI address bus bit 1.
				SD0_DAT2	I/O	MFP3	SD/SDIO0 data line bit 2.
				SPI1_MOSI	I/O	MFP5	SPI1 MOSI (Master Out, Slave In) pin.
				I2C0_SDA	I/O	MFP6	I2C0 data input/output pin.
				UART5_RXD	I	MFP7	UART5 data receiver input pin.
				USCI1_CTL1	I/O	MFP8	USCI1 control 1 pin.
				SC0_DAT	I/O	MFP9	Smart Card 0 data pin.
				I2S0_MCLK	O	MFP10	I2S0 master clock output pin.
				EPWM0_CH1	I/O	MFP11	EPWM0 channel 1 output/capture input.
				TM1	I/O	MFP14	Timer1 event counter input/toggle output pin.
INT1	I	MFP15	External interrupt 1 input pin.				
3	3	4	3	PB.3	I/O	MFP0	General purpose digital I/O pin.
				EADC0_CH3	A	MFP1	EADC0 channel 3 analog input.
				ACMP0_N	A	MFP1	Analog comparator 0 negative input pin.
				EBI_ADR2	O	MFP2	EBI address bus bit 2.

32 Pin	48 Pin	64 Pin	128 Pin	Pin Name	Type	MFP	Description
				SD0_DAT1	I/O	MFP3	SD/SDIO0 data line bit 1.
				SPI1_CLK	I/O	MFP5	SPI1 serial clock pin.
				UART1_TXD	O	MFP6	UART1 data transmitter output pin.
				UART5_nRTS	O	MFP7	UART5 request to Send output pin.
				USCI1_DAT1	I/O	MFP8	USCI1 data 1 pin.
				SC0_RST	O	MFP9	Smart Card 0 reset pin.
				I2S0_DI	I	MFP10	I2S0 data input pin.
				EPWM0_CH2	I/O	MFP11	EPWM0 channel 2 output/capture input.
				TM2	I/O	MFP14	Timer2 event counter input/toggle output pin.
				INT2	I	MFP15	External interrupt 2 input pin.
4	4	5	4	PB.2	I/O	MFP0	General purpose digital I/O pin.
				EADC0_CH2	A	MFP1	EADC0 channel 2 analog input.
				ACMP0_P1	A	MFP1	Analog comparator 0 positive input 1 pin.
				OPA0_O	A	MFP1	Operational amplifier 0 output pin.
				EBI_ADR3	O	MFP2	EBI address bus bit 3.
				SD0_DAT0	I/O	MFP3	SD/SDIO0 data line bit 0.
				SPI1_SS	I/O	MFP5	SPI1 slave select pin.
				UART1_RXD	I	MFP6	UART1 data receiver input pin.
				UART5_nCTS	I	MFP7	UART5 clear to Send input pin.
				USCI1_DAT0	I/O	MFP8	USCI1 data 0 pin.
				SC0_PWR	O	MFP9	Smart Card 0 power pin.
				I2S0_DO	O	MFP10	I2S0 data output pin.
				EPWM0_CH3	I/O	MFP11	EPWM0 channel 3 output/capture input.
				TM3	I/O	MFP14	Timer3 event counter input/toggle output pin.
				INT3	I	MFP15	External interrupt 3 input pin.
			5	PC.12	I/O	MFP0	General purpose digital I/O pin.
				EBI_ADR4	O	MFP2	EBI address bus bit 4.
				UART0_TXD	O	MFP3	UART0 data transmitter output pin.
				I2C0_SCL	I/O	MFP4	I2C0 clock pin.
				SPI3_MISO	I/O	MFP6	SPI3 MISO (Master In, Slave Out) pin.
				SC0_nCD	I	MFP9	Smart Card 0 card detect pin.
				ECAP1_IC2	I	MFP11	Enhanced capture unit 1 input 2 pin.
				EPWM1_CH0	I/O	MFP12	EPWM1 channel 0 output/capture input.

32 Pin	48 Pin	64 Pin	128 Pin	Pin Name	Type	MFP	Description
				ACMP0_O	O	MFP14	Analog comparator 0 output pin.
			6	PC.11	I/O	MFP0	General purpose digital I/O pin.
				EBI_ADR5	O	MFP2	EBI address bus bit 5.
				UART0_RXD	I	MFP3	UART0 data receiver input pin.
				I2C0_SDA	I/O	MFP4	I2C0 data input/output pin.
				SPI3_MOSI	I/O	MFP6	SPI3 MOSI (Master Out, Slave In) pin.
				ECAP1_IC1	I	MFP11	Enhanced capture unit 1 input 1 pin.
				EPWM1_CH1	I/O	MFP12	EPWM1 channel 1 output/capture input.
				ACMP1_O	O	MFP14	Analog comparator 1 output pin.
			7	PC.10	I/O	MFP0	General purpose digital I/O pin.
				EBI_ADR6	O	MFP2	EBI address bus bit 6.
				SPI3_CLK	I/O	MFP6	SPI3 serial clock pin.
				UART3_TXD	O	MFP7	UART3 data transmitter output pin.
				CAN1_TXD	O	MFP9	CAN1 bus transmitter output.
				ECAP1_IC0	I	MFP11	Enhanced capture unit 1 input 0 pin.
				EPWM1_CH2	I/O	MFP12	EPWM1 channel 2 output/capture input.
			8	PC.9	I/O	MFP0	General purpose digital I/O pin.
				EBI_ADR7	O	MFP2	EBI address bus bit 7.
				SPI3_SS	I/O	MFP6	SPI3 slave select pin.
				UART3_RXD	I	MFP7	UART3 data receiver input pin.
				CAN1_RXD	I	MFP9	CAN1 bus receiver input.
				EPWM1_CH3	I/O	MFP12	EPWM1 channel 3 output/capture input.
5	5	6	9	PB.1	I/O	MFP0	General purpose digital I/O pin.
				EADC0_CH1	A	MFP1	EADC0 channel 1 analog input.
				OPA0_N	A	MFP1	Operational amplifier 0 negative input pin.
				EBI_ADR8	O	MFP2	EBI address bus bit 8.
				SD0_CLK	O	MFP3	SD/SDIO0 clock output pin
				SPI1_I2SMCLK	I/O	MFP5	SPI1 I2S master clock output pin
				SPI3_I2SMCLK	I/O	MFP6	SPI3 I2S master clock output pin
				UART2_TXD	O	MFP7	UART2 data transmitter output pin.
				USC11_CLK	I/O	MFP8	USC11 clock pin.
				I2C1_SCL	I/O	MFP9	I2C1 clock pin.
				I2S0_LRCK	O	MFP10	I2S0 left right channel clock output pin.

32 Pin	48 Pin	64 Pin	128 Pin	Pin Name	Type	MFP	Description
				EPWM0_CH4	I/O	MFP11	EPWM0 channel 4 output/capture input.
				EPWM1_CH4	I/O	MFP12	EPWM1 channel 4 output/capture input.
				EPWM0_BRAKE0	I	MFP13	EPWM0 Brake 0 input pin.
6	6	7	10	PB.0	I/O	MFP0	General purpose digital I/O pin.
				EADC0_CH0	A	MFP1	EADC0 channel 0 analog input.
				OPA0_P	A	MFP1	Operational amplifier 0 positive input pin.
				EBI_ADR9	O	MFP2	EBI address bus bit 9.
				SD0_CMD	I/O	MFP3	SD/SDIO0 command/response pin
				UART2_RXD	I	MFP7	UART2 data receiver input pin.
				SPI0_I2SMCLK	I/O	MFP8	SPI0 I2S master clock output pin
				I2C1_SDA	I/O	MFP9	I2C1 data input/output pin.
				EPWM0_CH5	I/O	MFP11	EPWM0 channel 5 output/capture input.
				EPWM1_CH5	I/O	MFP12	EPWM1 channel 5 output/capture input.
				EPWM0_BRAKE1	I	MFP13	EPWM0 Brake 1 input pin.
			11	VSS	P	MFP0	Ground pin for digital circuit.
			12	V _{DD}	P	MFP0	Power supply for I/O ports and LDO source for internal PLL and digital circuit.
	7	8	13	PA.11	I/O	MFP0	General purpose digital I/O pin.
				ACMP0_P0	A	MFP1	Analog comparator 0 positive input 0 pin.
				EBI_nRD	O	MFP2	EBI read enable output pin.
				SC2_PWR	O	MFP3	Smart Card 2 power pin.
				SPI2_SS	I/O	MFP4	SPI2 slave select pin.
				SD1_DAT3	I/O	MFP5	SD/SDIO1 data line bit 3.
				USCI0_CLK	I/O	MFP6	USCI0 clock pin.
				I2C2_SCL	I/O	MFP7	I2C2 clock pin.
				BPWM0_CH0	I/O	MFP9	BPWM0 channel 0 output/capture input.
				EPWM0_SYNC_OUT	O	MFP10	EPWM0 counter synchronous trigger output pin.
				TM0_EXT	I/O	MFP13	Timer0 external capture input/toggle output pin.
				DAC1_ST	I	MFP14	DAC1 external trigger input.
	8	9	14	PA.10	I/O	MFP0	General purpose digital I/O pin.
				ACMP1_P0	A	MFP1	Analog comparator 1 positive input 0 pin.
				OPA1_O	A	MFP1	Operational amplifier 1 output pin.
				EBI_nWR	O	MFP2	EBI write enable output pin.
				SC2_RST	O	MFP3	Smart Card 2 reset pin.

32 Pin	48 Pin	64 Pin	128 Pin	Pin Name	Type	MFP	Description
				SPI2_CLK	I/O	MFP4	SPI2 serial clock pin.
				SD1_DAT2	I/O	MFP5	SD/SDIO1 data line bit 2.
				USCIO_DAT0	I/O	MFP6	USCIO data 0 pin.
				I2C2_SDA	I/O	MFP7	I2C2 data input/output pin.
				BPWM0_CH1	I/O	MFP9	BPWM0 channel 1 output/capture input.
				QE11_INDEX	I	MFP10	Quadrature encoder 1 index input
				ECAP0_IC0	I	MFP11	Enhanced capture unit 0 input 0 pin.
				TM1_EXT	I/O	MFP13	Timer1 external capture input/toggle output pin.
				DAC0_ST	I	MFP14	DAC0 external trigger input.
	9	10	15	PA.9	I/O	MFP0	General purpose digital I/O pin.
				OPA1_N	A	MFP1	Operational amplifier 1 negative input pin.
				EBI_MCLK	O	MFP2	EBI external clock output pin.
				SC2_DAT	I/O	MFP3	Smart Card 2 data pin.
				SPI2_MISO	I/O	MFP4	SPI2 MISO (Master In, Slave Out) pin.
				SD1_DAT1	I/O	MFP5	SD/SDIO1 data line bit 1.
				USCIO_DAT1	I/O	MFP6	USCIO data 1 pin.
				UART1_TXD	O	MFP7	UART1 data transmitter output pin.
				BPWM0_CH2	I/O	MFP9	BPWM0 channel 2 output/capture input.
				QE11_A	I	MFP10	Quadrature encoder 1 phase A input
				ECAP0_IC1	I	MFP11	Enhanced capture unit 0 input 1 pin.
				TM2_EXT	I/O	MFP13	Timer2 external capture input/toggle output pin.
	10	11	16	PA.8	I/O	MFP0	General purpose digital I/O pin.
				OPA1_P	A	MFP1	Operational amplifier 1 positive input pin.
				EBI_ALE	O	MFP2	EBI address latch enable output pin.
				SC2_CLK	O	MFP3	Smart Card 2 clock pin.
				SPI2_MOSI	I/O	MFP4	SPI2 MOSI (Master Out, Slave In) pin.
				SD1_DAT0	I/O	MFP5	SD/SDIO1 data line bit 0.
				USCIO_CTL1	I/O	MFP6	USCIO control 1 pin.
				UART1_RXD	I	MFP7	UART1 data receiver input pin.
				BPWM0_CH3	I/O	MFP9	BPWM0 channel 3 output/capture input.
				QE11_B	I	MFP10	Quadrature encoder 1 phase B input
				ECAP0_IC2	I	MFP11	Enhanced capture unit 0 input 2 pin.
				TM3_EXT	I/O	MFP13	Timer3 external capture input/toggle output pin.

32 Pin	48 Pin	64 Pin	128 Pin	Pin Name	Type	MFP	Description
				INT4	I	MFP15	External interrupt 4 input pin.
			17	PC.13	I/O	MFP0	General purpose digital I/O pin.
				EBI_ADR10	O	MFP2	EBI address bus bit 10.
				SC2_nCD	I	MFP3	Smart Card 2 card detect pin.
				SPI2_I2SMCLK	I/O	MFP4	SPI2 I2S master clock output pin
				CAN1_TXD	O	MFP5	CAN1 bus transmitter output.
				USCI0_CTL0	I/O	MFP6	USCI0 control 0 pin.
				UART2_TXD	O	MFP7	UART2 data transmitter output pin.
				BPWM0_CH4	I/O	MFP9	BPWM0 channel 4 output/capture input.
				CLKO	O	MFP13	Clock Out
				EADC0_ST	I	MFP14	EADC0 external trigger input.
			18	PD.12	I/O	MFP0	General purpose digital I/O pin.
				OPA2_O	A	MFP1	Operational amplifier 2 output pin.
				EBI_nCS0	O	MFP2	EBI chip select 0 output pin.
				CAN1_RXD	I	MFP5	CAN1 bus receiver input.
				UART2_RXD	I	MFP7	UART2 data receiver input pin.
				BPWM0_CH5	I/O	MFP9	BPWM0 channel 5 output/capture input.
				QEI0_INDEX	I	MFP10	Quadrature encoder 0 index input
				CLKO	O	MFP13	Clock Out
				EADC0_ST	I	MFP14	EADC0 external trigger input.
			INT5	I	MFP15	External interrupt 5 input pin.	
			19	PD.11	I/O	MFP0	General purpose digital I/O pin.
				OPA2_N	A	MFP1	Operational amplifier 2 negative input pin.
				EBI_nCS1	O	MFP2	EBI chip select 1 output pin.
				UART1_TXD	O	MFP3	UART1 data transmitter output pin.
				CAN0_TXD	O	MFP4	CAN0 bus transmitter output.
				QEI0_A	I	MFP10	Quadrature encoder 0 phase A input
				INT6	I	MFP15	External interrupt 6 input pin.
			20	PD.10	I/O	MFP0	General purpose digital I/O pin.
				OPA2_P	A	MFP1	Operational amplifier 2 positive input pin.
				EBI_nCS2	O	MFP2	EBI chip select 2 output pin.
				UART1_RXD	I	MFP3	UART1 data receiver input pin.
				CAN0_RXD	I	MFP4	CAN0 bus receiver input.

32 Pin	48 Pin	64 Pin	128 Pin	Pin Name	Type	MFP	Description
				QEIO_B	I	MFP10	Quadrature encoder 0 phase B input
				INT7	I	MFP15	External interrupt 7 input pin.
			21	PG.2	I/O	MFP0	General purpose digital I/O pin.
				EBI_ADR11	O	MFP2	EBI address bus bit 11.
				SPI2_SS	I/O	MFP3	SPI2 slave select pin.
				I2C0_SMBAL	O	MFP4	I2C0 SMBus SMBALTER pin
				I2C1_SCL	I/O	MFP5	I2C1 clock pin.
				TM0	I/O	MFP13	Timer0 event counter input/toggle output pin.
			22	PG.3	I/O	MFP0	General purpose digital I/O pin.
				EBI_ADR12	O	MFP2	EBI address bus bit 12.
				SPI2_CLK	I/O	MFP3	SPI2 serial clock pin.
				I2C0_SMBUS	O	MFP4	I2C0 SMBus SMBUS pin (PMBus CONTROL pin)
				I2C1_SDA	I/O	MFP5	I2C1 data input/output pin.
				TM1	I/O	MFP13	Timer1 event counter input/toggle output pin.
			23	PG.4	I/O	MFP0	General purpose digital I/O pin.
				EBI_ADR13	O	MFP2	EBI address bus bit 13.
				SPI2_MISO	I/O	MFP3	SPI2 MISO (Master In, Slave Out) pin.
				TM2	I/O	MFP13	Timer2 event counter input/toggle output pin.
			24	PF.11	I/O	MFP0	General purpose digital I/O pin.
				EBI_ADR14	O	MFP2	EBI address bus bit 14.
				SPI2_MOSI	I/O	MFP3	SPI2 MOSI (Master Out, Slave In) pin.
				TAMPER5	I/O	MFP10	TAMPER detector loop pin 5.
				TM3	I/O	MFP13	Timer3 event counter input/toggle output pin.
			25	PF.10	I/O	MFP0	General purpose digital I/O pin.
				EBI_ADR15	O	MFP2	EBI address bus bit 15.
				SC0_nCD	I	MFP3	Smart Card 0 card detect pin.
				I2S0_BCLK	O	MFP4	I2S0 bit clock output pin.
				SPI0_I2SMCLK	I/O	MFP5	SPI0 I2S master clock output pin
				TAMPER4	I/O	MFP10	TAMPER detector loop pin 4.
			26	PF.9	I/O	MFP0	General purpose digital I/O pin.
				EBI_ADR16	O	MFP2	EBI address bus bit 16.
				SC0_PWR	O	MFP3	Smart Card 0 power pin.
				I2S0_MCLK	O	MFP4	I2S0 master clock output pin.

32 Pin	48 Pin	64 Pin	128 Pin	Pin Name	Type	MFP	Description
				SPI0_SS	I/O	MFP5	SPI0 slave select pin.
				TAMPER3	I/O	MFP10	TAMPER detector loop pin 3.
			27	PF.8	I/O	MFP0	General purpose digital I/O pin.
				EBI_ADR17	O	MFP2	EBI address bus bit 17.
				SC0_RST	O	MFP3	Smart Card 0 reset pin.
				I2S0_DI	I	MFP4	I2S0 data input pin.
				SPI0_CLK	I/O	MFP5	SPI0 serial clock pin.
				TAMPER2	I/O	MFP10	TAMPER detector loop pin 2.
			28	PF.7	I/O	MFP0	General purpose digital I/O pin.
				EBI_ADR18	O	MFP2	EBI address bus bit 18.
				SC0_DAT	I/O	MFP3	Smart Card 0 data pin.
				I2S0_DO	O	MFP4	I2S0 data output pin.
				SPI0_MISO	I/O	MFP5	SPI0 MISO (Master In, Slave Out) pin.
				UART4_TXD	O	MFP6	UART4 data transmitter output pin.
				TAMPER1	I/O	MFP10	TAMPER detector loop pin 1.
		12	29	PF.6	I/O	MFP0	General purpose digital I/O pin.
				EBI_ADR19	O	MFP2	EBI address bus bit 19.
				SC0_CLK	O	MFP3	Smart Card 0 clock pin.
				I2S0_LRCK	O	MFP4	I2S0 left right channel clock output pin.
				SPI0_MOSI	I/O	MFP5	SPI0 MOSI (Master Out, Slave In) pin.
				UART4_RXD	I	MFP6	UART4 data receiver input pin.
				EBI_nCS0	O	MFP7	EBI chip select 0 output pin.
				TAMPER0	I/O	MFP10	TAMPER detector loop pin 0.
		13	30	V _{DD}	P	MFP0	Power supply for I/O ports and LDO source for internal PLL and digital circuit.
7	11	14	31	PF.5	I/O	MFP0	General purpose digital I/O pin.
				UART2_RXD	I	MFP2	UART2 data receiver input pin.
				UART2_nCTS	I	MFP4	UART2 clear to Send input pin.
				BPWM0_CH4	I/O	MFP8	BPWM0 channel 4 output/capture input.
				EPWM0_SYNC_OUT	O	MFP9	EPWM0 counter synchronous trigger output pin.
				X32_IN	I	MFP10	External 32.768 kHz crystal input pin.
				EADC0_ST	I	MFP11	EADC0 external trigger input.
8	12	15	32	PF.4	I/O	MFP0	General purpose digital I/O pin.
				UART2_TXD	O	MFP2	UART2 data transmitter output pin.

32 Pin	48 Pin	64 Pin	128 Pin	Pin Name	Type	MFP	Description
				UART2_nRTS	O	MFP4	UART2 request to Send output pin.
				BPWM0_CH5	I/O	MFP8	BPWM0 channel 5 output/capture input.
				X32_OUT	O	MFP10	External 32.768 kHz crystal output pin.
			33	PH.4	I/O	MFP0	General purpose digital I/O pin.
				EBI_ADR3	O	MFP2	EBI address bus bit 3.
				SPI1_MISO	I/O	MFP3	SPI1 MISO (Master In, Slave Out) pin.
			34	PH.5	I/O	MFP0	General purpose digital I/O pin.
				EBI_ADR2	O	MFP2	EBI address bus bit 2.
				SPI1_MOSI	I/O	MFP3	SPI1 MOSI (Master Out, Slave In) pin.
			35	PH.6	I/O	MFP0	General purpose digital I/O pin.
				EBI_ADR1	O	MFP2	EBI address bus bit 1.
				SPI1_CLK	I/O	MFP3	SPI1 serial clock pin.
			36	PH.7	I/O	MFP0	General purpose digital I/O pin.
				EBI_ADR0	O	MFP2	EBI address bus bit 0.
				SPI1_SS	I/O	MFP3	SPI1 slave select pin.
9	13	16	37	PF.3	I/O	MFP0	General purpose digital I/O pin.
				EBI_nCS0	O	MFP2	EBI chip select 0 output pin.
				UART0_TXD	O	MFP3	UART0 data transmitter output pin.
				I2C0_SCL	I/O	MFP4	I2C0 clock pin.
				XT1_IN	I	MFP10	External 4~24 MHz (high speed) crystal input pin.
				BPWM1_CH0	I/O	MFP11	BPWM1 channel 0 output/capture input.
10	14	17	38	PF.2	I/O	MFP0	General purpose digital I/O pin.
				EBI_nCS1	O	MFP2	EBI chip select 1 output pin.
				UART0_RXD	I	MFP3	UART0 data receiver input pin.
				I2C0_SDA	I/O	MFP4	I2C0 data input/output pin.
				QSPI0_CLK	I/O	MFP5	Quad SPI0 serial clock pin.
				XT1_OUT	O	MFP10	External 4~24 MHz (high speed) crystal output pin.
				BPWM1_CH1	I/O	MFP11	BPWM1 channel 1 output/capture input.
			39	VSS	P	MFP0	Ground pin for digital circuit.
			40	V _{DD}	P	MFP0	Power supply for I/O ports and LDO source for internal PLL and digital circuit.
			41	PE.8	I/O	MFP0	General purpose digital I/O pin.
				EBI_ADR10	O	MFP2	EBI address bus bit 10.
				I2S0_BCLK	O	MFP4	I2S0 bit clock output pin.

32 Pin	48 Pin	64 Pin	128 Pin	Pin Name	Type	MFP	Description
				SPI2_CLK	I/O	MFP5	SPI2 serial clock pin.
				USCI1_CTL1	I/O	MFP6	USCI1 control 1 pin.
				UART2_TXD	O	MFP7	UART2 data transmitter output pin.
				EPWM0_CH0	I/O	MFP10	EPWM0 channel 0 output/capture input.
				EPWM0_BRAKE0	I	MFP11	EPWM0 Brake 0 input pin.
				ECAP0_IC0	I	MFP12	Enhanced capture unit 0 input 0 pin.
				TRACE_CLK	O	MFP14	ETM Trace Clock output pin
			42	PE.9	I/O	MFP0	General purpose digital I/O pin.
				EBI_ADR11	O	MFP2	EBI address bus bit 11.
				I2S0_MCLK	O	MFP4	I2S0 master clock output pin.
				SPI2_MISO	I/O	MFP5	SPI2 MISO (Master In, Slave Out) pin.
				USCI1_CTL0	I/O	MFP6	USCI1 control 0 pin.
				UART2_RXD	I	MFP7	UART2 data receiver input pin.
				EPWM0_CH1	I/O	MFP10	EPWM0 channel 1 output/capture input.
				EPWM0_BRAKE1	I	MFP11	EPWM0 Brake 1 input pin.
				ECAP0_IC1	I	MFP12	Enhanced capture unit 0 input 1 pin.
				TRACE_DATA0	O	MFP14	ETM Trace Data 0 output pin
			43	PE.10	I/O	MFP0	General purpose digital I/O pin.
				EBI_ADR12	O	MFP2	EBI address bus bit 12.
				I2S0_DI	I	MFP4	I2S0 data input pin.
				SPI2_MOSI	I/O	MFP5	SPI2 MOSI (Master Out, Slave In) pin.
				USCI1_DAT0	I/O	MFP6	USCI1 data 0 pin.
				UART3_TXD	O	MFP7	UART3 data transmitter output pin.
				EPWM0_CH2	I/O	MFP10	EPWM0 channel 2 output/capture input.
				EPWM1_BRAKE0	I	MFP11	EPWM1 Brake 0 input pin.
				ECAP0_IC2	I	MFP12	Enhanced capture unit 0 input 2 pin.
				TRACE_DATA1	O	MFP14	ETM Trace Data 1 output pin
			44	PE.11	I/O	MFP0	General purpose digital I/O pin.
				EBI_ADR13	O	MFP2	EBI address bus bit 13.
				I2S0_DO	O	MFP4	I2S0 data output pin.
				SPI2_SS	I/O	MFP5	SPI2 slave select pin.
				USCI1_DAT1	I/O	MFP6	USCI1 data 1 pin.
				UART3_RXD	I	MFP7	UART3 data receiver input pin.

32 Pin	48 Pin	64 Pin	128 Pin	Pin Name	Type	MFP	Description
				UART1_nCTS	I	MFP8	UART1 clear to Send input pin.
				EPWM0_CH3	I/O	MFP10	EPWM0 channel 3 output/capture input.
				EPWM1_BRAKE1	I	MFP11	EPWM1 Brake 1 input pin.
				ECAP1_IC2	I	MFP13	Enhanced capture unit 1 input 2 pin.
				TRACE_DATA2	O	MFP14	ETM Trace Data 2 output pin
			45	PE.12	I/O	MFP0	General purpose digital I/O pin.
				EBI_ADR14	O	MFP2	EBI address bus bit 14.
				I2S0_LRCK	O	MFP4	I2S0 left right channel clock output pin.
				SPI2_I2SMCLK	I/O	MFP5	SPI2 I2S master clock output pin
				USCI1_CLK	I/O	MFP6	USCI1 clock pin.
				UART1_nRTS	O	MFP8	UART1 request to Send output pin.
				EPWM0_CH4	I/O	MFP10	EPWM0 channel 4 output/capture input.
				ECAP1_IC1	I	MFP13	Enhanced capture unit 1 input 1 pin.
				TRACE_DATA3	O	MFP14	ETM Trace Data 3 output pin
			46	PE.13	I/O	MFP0	General purpose digital I/O pin.
				EBI_ADR15	O	MFP2	EBI address bus bit 15.
				I2C0_SCL	I/O	MFP4	I2C0 clock pin.
				UART4_nRTS	O	MFP5	UART4 request to Send output pin.
				UART1_TXD	O	MFP8	UART1 data transmitter output pin.
				EPWM0_CH5	I/O	MFP10	EPWM0 channel 5 output/capture input.
				EPWM1_CH0	I/O	MFP11	EPWM1 channel 0 output/capture input.
				BPWM1_CH5	I/O	MFP12	BPWM1 channel 5 output/capture input.
				ECAP1_IC0	I	MFP13	Enhanced capture unit 1 input 0 pin.
			47	PC.8	I/O	MFP0	General purpose digital I/O pin.
				EBI_ADR16	O	MFP2	EBI address bus bit 16.
				I2C0_SDA	I/O	MFP4	I2C0 data input/output pin.
				UART4_nCTS	I	MFP5	UART4 clear to Send input pin.
				UART1_RXD	I	MFP8	UART1 data receiver input pin.
				EPWM1_CH1	I/O	MFP11	EPWM1 channel 1 output/capture input.
				BPWM1_CH4	I/O	MFP12	BPWM1 channel 4 output/capture input.
		18	48	PC.7	I/O	MFP0	General purpose digital I/O pin.
				EBI_AD9	I/O	MFP2	EBI address/data bus bit 9.
				SPI1_MISO	I/O	MFP4	SPI1 MISO (Master In, Slave Out) pin.

32 Pin	48 Pin	64 Pin	128 Pin	Pin Name	Type	MFP	Description
				UART4_TXD	O	MFP5	UART4 data transmitter output pin.
				SC2_PWR	O	MFP6	Smart Card 2 power pin.
				UART0_nCTS	I	MFP7	UART0 clear to Send input pin.
				I2C1_SMBAL	O	MFP8	I2C1 SMBus SMBALTER pin
				EPWM1_CH2	I/O	MFP11	EPWM1 channel 2 output/capture input.
				BPWM1_CH0	I/O	MFP12	BPWM1 channel 0 output/capture input.
				TM0	I/O	MFP14	Timer0 event counter input/toggle output pin.
				INT3	I	MFP15	External interrupt 3 input pin.
		19	49	PC.6	I/O	MFP0	General purpose digital I/O pin.
				EBI_AD8	I/O	MFP2	EBI address/data bus bit 8.
				SPI1_MOSI	I/O	MFP4	SPI1 MOSI (Master Out, Slave In) pin.
				UART4_RXD	I	MFP5	UART4 data receiver input pin.
				SC2_RST	O	MFP6	Smart Card 2 reset pin.
				UART0_nRTS	O	MFP7	UART0 request to Send output pin.
				I2C1_SMBSUS	O	MFP8	I2C1 SMBus SMBSUS pin (PMBus CONTROL pin)
				EPWM1_CH3	I/O	MFP11	EPWM1 channel 3 output/capture input.
				BPWM1_CH1	I/O	MFP12	BPWM1 channel 1 output/capture input.
				TM1	I/O	MFP14	Timer1 event counter input/toggle output pin.
				INT2	I	MFP15	External interrupt 2 input pin.
	15	20	50	PA.7	I/O	MFP0	General purpose digital I/O pin.
				EBI_AD7	I/O	MFP2	EBI address/data bus bit 7.
				SPI1_CLK	I/O	MFP4	SPI1 serial clock pin.
				SC2_DAT	I/O	MFP6	Smart Card 2 data pin.
				UART0_TXD	O	MFP7	UART0 data transmitter output pin.
				I2C1_SCL	I/O	MFP8	I2C1 clock pin.
				EPWM1_CH4	I/O	MFP11	EPWM1 channel 4 output/capture input.
				BPWM1_CH2	I/O	MFP12	BPWM1 channel 2 output/capture input.
				ACMP0_WLAT	I	MFP13	Analog comparator 0 window latch input pin
				TM2	I/O	MFP14	Timer2 event counter input/toggle output pin.
				INT1	I	MFP15	External interrupt 1 input pin.
	16	21	51	PA.6	I/O	MFP0	General purpose digital I/O pin.
				EBI_AD6	I/O	MFP2	EBI address/data bus bit 6.
				SPI1_SS	I/O	MFP4	SPI1 slave select pin.

32 Pin	48 Pin	64 Pin	128 Pin	Pin Name	Type	MFP	Description
				SD1_nCD	I	MFP5	SD/SDIO1 card detect input pin
				SC2_CLK	O	MFP6	Smart Card 2 clock pin.
				UART0_RXD	I	MFP7	UART0 data receiver input pin.
				I2C1_SDA	I/O	MFP8	I2C1 data input/output pin.
				EPWM1_CH5	I/O	MFP11	EPWM1 channel 5 output/capture input.
				BPWM1_CH3	I/O	MFP12	BPWM1 channel 3 output/capture input.
				ACMP1_WLAT	I	MFP13	Analog comparator 1 window latch input pin
				TM3	I/O	MFP14	Timer3 event counter input/toggle output pin.
				INT0	I	MFP15	External interrupt 0 input pin.
		22	52	VSS	P	MFP0	Ground pin for digital circuit.
		23	53	V _{DD}	P	MFP0	Power supply for I/O ports and LDO source for internal PLL and digital circuit.
		24	54	LDO_CAP	A	MFP0	LDO output pin.
	17	25	55	PA.5	I/O	MFP0	General purpose digital I/O pin.
				SPIM_D2	I/O	MFP2	SPIM data 2 pin for Quad Mode I/O.
				QSPI0_MISO1	I/O	MFP3	Quad SPI0 MISO1 (Master In, Slave Out) pin.
				SPI1_I2SMCLK	I/O	MFP4	SPI1 I2S master clock output pin
				SD1_CMD	I/O	MFP5	SD/SDIO1 command/response pin
				SC2_nCD	I	MFP6	Smart Card 2 card detect pin.
				UART0_nCTS	I	MFP7	UART0 clear to Send input pin.
				UART5_TXD	O	MFP8	UART5 data transmitter output pin.
				I2C0_SCL	I/O	MFP9	I2C0 clock pin.
				CAN0_TXD	O	MFP10	CAN0 bus transmitter output.
				BPWM0_CH5	I/O	MFP12	BPWM0 channel 5 output/capture input.
				EPWM0_CH0	I/O	MFP13	EPWM0 channel 0 output/capture input.
				QEIO_INDEX	I	MFP14	Quadrature encoder 0 index input
	18	26	56	PA.4	I/O	MFP0	General purpose digital I/O pin.
				SPIM_D3	I/O	MFP2	SPIM data 3 pin for Quad Mode I/O.
				QSPI0_MOSI1	I/O	MFP3	Quad SPI0 MOSI1 (Master Out, Slave In) pin.
				SPI0_I2SMCLK	I/O	MFP4	SPI0 I2S master clock output pin
				SD1_CLK	O	MFP5	SD/SDIO1 clock output pin
				SC0_nCD	I	MFP6	Smart Card 0 card detect pin.
				UART0_nRTS	O	MFP7	UART0 request to Send output pin.
				UART5_RXD	I	MFP8	UART5 data receiver input pin.

32 Pin	48 Pin	64 Pin	128 Pin	Pin Name	Type	MFP	Description
				I2C0_SDA	I/O	MFP9	I2C0 data input/output pin.
				CAN0_RXD	I	MFP10	CAN0 bus receiver input.
				BPWM0_CH4	I/O	MFP12	BPWM0 channel 4 output/capture input.
				EPWM0_CH1	I/O	MFP13	EPWM0 channel 1 output/capture input.
				QEI0_A	I	MFP14	Quadrature encoder 0 phase A input
11	19	27	57	PA.3	I/O	MFP0	General purpose digital I/O pin.
				SPIM_SS	I/O	MFP2	SPIM slave select pin.
				QSPIO_SS	I/O	MFP3	Quad SPI0 slave select pin.
				SPIO_SS	I/O	MFP4	SPIO slave select pin.
				SD1_DAT3	I/O	MFP5	SD/SDIO1 data line bit 3.
				SC0_PWR	O	MFP6	Smart Card 0 power pin.
				UART4_TXD	O	MFP7	UART4 data transmitter output pin.
				UART1_TXD	O	MFP8	UART1 data transmitter output pin.
				I2C1_SCL	I/O	MFP9	I2C1 clock pin.
				BPWM0_CH3	I/O	MFP12	BPWM0 channel 3 output/capture input.
				EPWM0_CH2	I/O	MFP13	EPWM0 channel 2 output/capture input.
				QEI0_B	I	MFP14	Quadrature encoder 0 phase B input
12	20	28	58	PA.2	I/O	MFP0	General purpose digital I/O pin.
				SPIM_CLK	I/O	MFP2	SPIM serial clock pin.
				QSPIO_CLK	I/O	MFP3	Quad SPI0 serial clock pin.
				SPIO_CLK	I/O	MFP4	SPIO serial clock pin.
				SD1_DAT2	I/O	MFP5	SD/SDIO1 data line bit 2.
				SC0_RST	O	MFP6	Smart Card 0 reset pin.
				UART4_RXD	I	MFP7	UART4 data receiver input pin.
				UART1_RXD	I	MFP8	UART1 data receiver input pin.
				I2C1_SDA	I/O	MFP9	I2C1 data input/output pin.
				BPWM0_CH2	I/O	MFP12	BPWM0 channel 2 output/capture input.
				EPWM0_CH3	I/O	MFP13	EPWM0 channel 3 output/capture input.
13	21	29	59	PA.1	I/O	MFP0	General purpose digital I/O pin.
				SPIM_MISO	I/O	MFP2	SPIM MISO (Master In, Slave Out) pin.
				QSPIO_MISO0	I/O	MFP3	Quad SPI0 MISO0 (Master In, Slave Out) pin.
				SPIO_MISO	I/O	MFP4	SPIO MISO (Master In, Slave Out) pin.
				SD1_DAT1	I/O	MFP5	SD/SDIO1 data line bit 1.

32 Pin	48 Pin	64 Pin	128 Pin	Pin Name	Type	MFP	Description
				SC0_DAT	I/O	MFP6	Smart Card 0 data pin.
				UART0_TXD	O	MFP7	UART0 data transmitter output pin.
				UART1_nCTS	I	MFP8	UART1 clear to Send input pin.
				I2C2_SCL	I/O	MFP9	I2C2 clock pin.
				BPWM0_CH1	I/O	MFP12	BPWM0 channel 1 output/capture input.
				EPWM0_CH4	I/O	MFP13	EPWM0 channel 4 output/capture input.
				DAC1_ST	I	MFP15	DAC1 external trigger input.
14	22	30	60	PA.0	I/O	MFP0	General purpose digital I/O pin.
				SPIM_MOSI	I/O	MFP2	SPIM MOSI (Master Out, Slave In) pin.
				QSPI0_MOSI0	I/O	MFP3	Quad SPI0 MOSI0 (Master Out, Slave In) pin.
				SPI0_MOSI	I/O	MFP4	SPI0 MOSI (Master Out, Slave In) pin.
				SD1_DAT0	I/O	MFP5	SD/SDIO1 data line bit 0.
				SC0_CLK	O	MFP6	Smart Card 0 clock pin.
				UART0_RXD	I	MFP7	UART0 data receiver input pin.
				UART1_nRTS	O	MFP8	UART1 request to Send output pin.
				I2C2_SDA	I/O	MFP9	I2C2 data input/output pin.
				BPWM0_CH0	I/O	MFP12	BPWM0 channel 0 output/capture input.
				EPWM0_CH5	I/O	MFP13	EPWM0 channel 5 output/capture input.
				DAC0_ST	I	MFP15	DAC0 external trigger input.
15	23	31	61	V _{DDIO}	P	MFP0	Power supply for PA.0~PA.5.
			62	PE.14	I/O	MFP0	General purpose digital I/O pin.
				EBI_AD8	I/O	MFP2	EBI address/data bus bit 8.
				UART2_TXD	O	MFP3	UART2 data transmitter output pin.
				CAN0_TXD	O	MFP4	CAN0 bus transmitter output.
				SD1_nCD	I	MFP5	SD/SDIO1 card detect input pin
			63	PE.15	I/O	MFP0	General purpose digital I/O pin.
				EBI_AD9	I/O	MFP2	EBI address/data bus bit 9.
				UART2_RXD	I	MFP3	UART2 data receiver input pin.
				CAN0_RXD	I	MFP4	CAN0 bus receiver input.
16	24	32	64	nRESET	I	MFP0	External reset input: active LOW, with an internal pull-up. Set this pin low reset to initial state.
17	25	33	65	PF.0	I/O	MFP0	General purpose digital I/O pin.
				UART1_TXD	O	MFP2	UART1 data transmitter output pin.
				I2C1_SCL	I/O	MFP3	I2C1 clock pin.

32 Pin	48 Pin	64 Pin	128 Pin	Pin Name	Type	MFP	Description
				BPWM1_CH0	I/O	MFP12	BPWM1 channel 0 output/capture input.
				ICE_DAT	O	MFP14	Serial wired debugger data pin.
18	26	34	66	PF.1	I/O	MFP0	General purpose digital I/O pin.
				UART1_RXD	I	MFP2	UART1 data receiver input pin.
				I2C1_SDA	I/O	MFP3	I2C1 data input/output pin.
				BPWM1_CH1	I/O	MFP12	BPWM1 channel 1 output/capture input.
				ICE_CLK	I	MFP14	Serial wired debugger clock pin.
			67	PD.9	I/O	MFP0	General purpose digital I/O pin.
				EBI_AD7	I/O	MFP2	EBI address/data bus bit 7.
				I2C2_SCL	I/O	MFP3	I2C2 clock pin.
				UART2_nCTS	I	MFP4	UART2 clear to Send input pin.
			68	PD.8	I/O	MFP0	General purpose digital I/O pin.
				EBI_AD6	I/O	MFP2	EBI address/data bus bit 6.
				I2C2_SDA	I/O	MFP3	I2C2 data input/output pin.
				UART2_nRTS	O	MFP4	UART2 request to Send output pin.
	27	35	69	PC.5	I/O	MFP0	General purpose digital I/O pin.
				EBI_AD5	I/O	MFP2	EBI address/data bus bit 5.
				SPIM_D2	I/O	MFP3	SPIM data 2 pin for Quad Mode I/O.
				QSPI0_MISO1	I/O	MFP4	Quad SPI0 MISO1 (Master In, Slave Out) pin.
				UART2_TXD	O	MFP8	UART2 data transmitter output pin.
				I2C1_SCL	I/O	MFP9	I2C1 clock pin.
				CAN0_TXD	O	MFP10	CAN0 bus transmitter output.
				UART4_TXD	O	MFP11	UART4 data transmitter output pin.
				EPWM1_CH0	I/O	MFP12	EPWM1 channel 0 output/capture input.
	28	36	70	PC.4	I/O	MFP0	General purpose digital I/O pin.
				EBI_AD4	I/O	MFP2	EBI address/data bus bit 4.
				SPIM_D3	I/O	MFP3	SPIM data 3 pin for Quad Mode I/O.
				QSPI0_MOSI1	I/O	MFP4	Quad SPI0 MOSI1 (Master Out, Slave In) pin.
				SC1_nCD	I	MFP5	Smart Card 1 card detect pin.
				I2S0_BCLK	O	MFP6	I2S0 bit clock output pin.
				SPI1_I2SMCLK	I/O	MFP7	SPI1 I2S master clock output pin
				UART2_RXD	I	MFP8	UART2 data receiver input pin.
				I2C1_SDA	I/O	MFP9	I2C1 data input/output pin.

32 Pin	48 Pin	64 Pin	128 Pin	Pin Name	Type	MFP	Description
				CAN0_RXD	I	MFP10	CAN0 bus receiver input.
				UART4_RXD	I	MFP11	UART4 data receiver input pin.
				EPWM1_CH1	I/O	MFP12	EPWM1 channel 1 output/capture input.
	29	37	71	PC.3	I/O	MFP0	General purpose digital I/O pin.
				EBI_AD3	I/O	MFP2	EBI address/data bus bit 3.
				SPIM_SS	I/O	MFP3	SPIM slave select pin.
				QSPIO_SS	I/O	MFP4	Quad SPI0 slave select pin.
				SC1_PWR	O	MFP5	Smart Card 1 power pin.
				I2S0_MCLK	O	MFP6	I2S0 master clock output pin.
				SPI1_MISO	I/O	MFP7	SPI1 MISO (Master In, Slave Out) pin.
				UART2_nRTS	O	MFP8	UART2 request to Send output pin.
				I2C0_SMBAL	O	MFP9	I2C0 SMBus SMBALTER pin
				CAN1_TXD	O	MFP10	CAN1 bus transmitter output.
				UART3_TXD	O	MFP11	UART3 data transmitter output pin.
				EPWM1_CH2	I/O	MFP12	EPWM1 channel 2 output/capture input.
	30	38	72	PC.2	I/O	MFP0	General purpose digital I/O pin.
				EBI_AD2	I/O	MFP2	EBI address/data bus bit 2.
				SPIM_CLK	I/O	MFP3	SPIM serial clock pin.
				QSPIO_CLK	I/O	MFP4	Quad SPI0 serial clock pin.
				SC1_RST	O	MFP5	Smart Card 1 reset pin.
				I2S0_DI	I	MFP6	I2S0 data input pin.
				SPI1_MOSI	I/O	MFP7	SPI1 MOSI (Master Out, Slave In) pin.
				UART2_nCTS	I	MFP8	UART2 clear to Send input pin.
				I2C0_SMBUSUS	O	MFP9	I2C0 SMBus SMBUSUS pin (PMBus CONTROL pin)
				CAN1_RXD	I	MFP10	CAN1 bus receiver input.
				UART3_RXD	I	MFP11	UART3 data receiver input pin.
				EPWM1_CH3	I/O	MFP12	EPWM1 channel 3 output/capture input.
19	31	39	73	PC.1	I/O	MFP0	General purpose digital I/O pin.
				EBI_AD1	I/O	MFP2	EBI address/data bus bit 1.
				SPIM_MISO	I/O	MFP3	SPIM MISO (Master In, Slave Out) pin.
				QSPIO_MISO0	I/O	MFP4	Quad SPI0 MISO0 (Master In, Slave Out) pin.
				SC1_DAT	I/O	MFP5	Smart Card 1 data pin.
				I2S0_DO	O	MFP6	I2S0 data output pin.

32 Pin	48 Pin	64 Pin	128 Pin	Pin Name	Type	MFP	Description
				SPI1_CLK	I/O	MFP7	SPI1 serial clock pin.
				UART2_TXD	O	MFP8	UART2 data transmitter output pin.
				I2C0_SCL	I/O	MFP9	I2C0 clock pin.
				EPWM1_CH4	I/O	MFP12	EPWM1 channel 4 output/capture input.
				ACMP0_O	O	MFP14	Analog comparator 0 output pin.
20	32	40	74	PC.0	I/O	MFP0	General purpose digital I/O pin.
				EBI_AD0	I/O	MFP2	EBI address/data bus bit 0.
				SPIM_MOSI	I/O	MFP3	SPIM MOSI (Master Out, Slave In) pin.
				QSPIO_MOSI0	I/O	MFP4	Quad SPI0 MOSI0 (Master Out, Slave In) pin.
				SC1_CLK	O	MFP5	Smart Card 1 clock pin.
				I2S0_LRCK	O	MFP6	I2S0 left right channel clock output pin.
				SPI1_SS	I/O	MFP7	SPI1 slave select pin.
				UART2_RXD	I	MFP8	UART2 data receiver input pin.
				I2C0_SDA	I/O	MFP9	I2C0 data input/output pin.
				EPWM1_CH5	I/O	MFP12	EPWM1 channel 5 output/capture input.
				ACMP1_O	O	MFP14	Analog comparator 1 output pin.
			75	VSS	P	MFP0	Ground pin for digital circuit.
			76	V _{DD}	P	MFP0	Power supply for I/O ports and LDO source for internal PLL and digital circuit.
			77	PG.9	I/O	MFP0	General purpose digital I/O pin.
				EBI_AD0	I/O	MFP2	EBI address/data bus bit 0.
				SD1_DAT3	I/O	MFP3	SD/SDIO1 data line bit 3.
				SPIM_D2	I/O	MFP4	SPIM data 2 pin for Quad Mode I/O.
				BPWM0_CH5	I/O	MFP12	BPWM0 channel 5 output/capture input.
			78	PG.10	I/O	MFP0	General purpose digital I/O pin.
				EBI_AD1	I/O	MFP2	EBI address/data bus bit 1.
				SD1_DAT2	I/O	MFP3	SD/SDIO1 data line bit 2.
				SPIM_D3	I/O	MFP4	SPIM data 3 pin for Quad Mode I/O.
				BPWM0_CH4	I/O	MFP12	BPWM0 channel 4 output/capture input.
			79	PG.11	I/O	MFP0	General purpose digital I/O pin.
				EBI_AD2	I/O	MFP2	EBI address/data bus bit 2.
				SD1_DAT1	I/O	MFP3	SD/SDIO1 data line bit 1.
				SPIM_SS	I/O	MFP4	SPIM slave select pin.
				BPWM0_CH3	I/O	MFP12	BPWM0 channel 3 output/capture input.

32 Pin	48 Pin	64 Pin	128 Pin	Pin Name	Type	MFP	Description
			80	PG.12	I/O	MFP0	General purpose digital I/O pin.
				EBI_AD3	I/O	MFP2	EBI address/data bus bit 3.
				SD1_DAT0	I/O	MFP3	SD/SDIO1 data line bit 0.
				SPIM_CLK	I/O	MFP4	SPIM serial clock pin.
				BPWM0_CH2	I/O	MFP12	BPWM0 channel 2 output/capture input.
			81	PG.13	I/O	MFP0	General purpose digital I/O pin.
				EBI_AD4	I/O	MFP2	EBI address/data bus bit 4.
				SD1_CMD	I/O	MFP3	SD/SDIO1 command/response pin
				SPIM_MISO	I/O	MFP4	SPIM MISO (Master In, Slave Out) pin.
				BPWM0_CH1	I/O	MFP12	BPWM0 channel 1 output/capture input.
			82	PG.14	I/O	MFP0	General purpose digital I/O pin.
				EBI_AD5	I/O	MFP2	EBI address/data bus bit 5.
				SD1_CLK	O	MFP3	SD/SDIO1 clock output pin
				SPIM_MOSI	I/O	MFP4	SPIM MOSI (Master Out, Slave In) pin.
				BPWM0_CH0	I/O	MFP12	BPWM0 channel 0 output/capture input.
			83	PG.15	I/O	MFP0	General purpose digital I/O pin.
				SD1_nCD	I	MFP3	SD/SDIO1 card detect input pin
				CLKO	O	MFP14	Clock Out
				EADC0_ST	I	MFP15	EADC0 external trigger input.
		41		PD.3	I/O	MFP0	General purpose digital I/O pin.
				EBI_AD10	I/O	MFP2	EBI address/data bus bit 10.
				USCI0_CTL1	I/O	MFP3	USCI0 control 1 pin.
				SPI0_SS	I/O	MFP4	SPI0 slave select pin.
				UART3_nRTS	O	MFP5	UART3 request to Send output pin.
				USCI1_CTL0	I/O	MFP6	USCI1 control 0 pin.
				SC2_PWR	O	MFP7	Smart Card 2 power pin.
				SC1_nCD	I	MFP8	Smart Card 1 card detect pin.
				UART0_TXD	O	MFP9	UART0 data transmitter output pin.
		42		PD.2	I/O	MFP0	General purpose digital I/O pin.
				EBI_AD11	I/O	MFP2	EBI address/data bus bit 11.
				USCI0_DAT1	I/O	MFP3	USCI0 data 1 pin.
				SPI0_CLK	I/O	MFP4	SPI0 serial clock pin.
				UART3_nCTS	I	MFP5	UART3 clear to Send input pin.

32 Pin	48 Pin	64 Pin	128 Pin	Pin Name	Type	MFP	Description
				SC2_RST	O	MFP7	Smart Card 2 reset pin.
				UART0_RXD	I	MFP9	UART0 data receiver input pin.
		43		PD.1	I/O	MFP0	General purpose digital I/O pin.
				EBI_AD12	I/O	MFP2	EBI address/data bus bit 12.
				USCI0_DAT0	I/O	MFP3	USCI0 data 0 pin.
				SPI0_MISO	I/O	MFP4	SPI0 MISO (Master In, Slave Out) pin.
				UART3_TXD	O	MFP5	UART3 data transmitter output pin.
				I2C2_SCL	I/O	MFP6	I2C2 clock pin.
				SC2_DAT	I/O	MFP7	Smart Card 2 data pin.
		44		PD.0	I/O	MFP0	General purpose digital I/O pin.
				EBI_AD13	I/O	MFP2	EBI address/data bus bit 13.
				USCI0_CLK	I/O	MFP3	USCI0 clock pin.
				SPI0_MOSI	I/O	MFP4	SPI0 MOSI (Master Out, Slave In) pin.
				UART3_RXD	I	MFP5	UART3 data receiver input pin.
				I2C2_SDA	I/O	MFP6	I2C2 data input/output pin.
				SC2_CLK	O	MFP7	Smart Card 2 clock pin.
				TM2	I/O	MFP14	Timer2 event counter input/toggle output pin.
			84	PD.13	I/O	MFP0	General purpose digital I/O pin.
				EBI_AD10	I/O	MFP2	EBI address/data bus bit 10.
				SD0_nCD	I	MFP3	SD/SDIO0 card detect input pin
				SPI0_I2SMCLK	I/O	MFP4	SPI0 I2S master clock output pin
				SPI1_I2SMCLK	I/O	MFP5	SPI1 I2S master clock output pin
				SC2_nCD	I	MFP7	Smart Card 2 card detect pin.
21	33	45	85	PA.12	I/O	MFP0	General purpose digital I/O pin.
				I2S0_BCLK	O	MFP2	I2S0 bit clock output pin.
				UART4_TXD	O	MFP3	UART4 data transmitter output pin.
				I2C1_SCL	I/O	MFP4	I2C1 clock pin.
				SPI2_SS	I/O	MFP5	SPI2 slave select pin.
				CAN0_TXD	O	MFP6	CAN0 bus transmitter output.
				SC2_PWR	O	MFP7	Smart Card 2 power pin.
				BPWM1_CH2	I/O	MFP11	BPWM1 channel 2 output/capture input.
				QE11_INDEX	I	MFP12	Quadrature encoder 1 index input
				USB_VBUS	P	MFP14	Power supply from USB host or HUB.

32 Pin	48 Pin	64 Pin	128 Pin	Pin Name	Type	MFP	Description
22	34	46	86	PA.13	I/O	MFP0	General purpose digital I/O pin.
				I2S0_MCLK	O	MFP2	I2S0 master clock output pin.
				UART4_RXD	I	MFP3	UART4 data receiver input pin.
				I2C1_SDA	I/O	MFP4	I2C1 data input/output pin.
				SPI2_CLK	I/O	MFP5	SPI2 serial clock pin.
				CAN0_RXD	I	MFP6	CAN0 bus receiver input.
				SC2_RST	O	MFP7	Smart Card 2 reset pin.
				BPWM1_CH3	I/O	MFP11	BPWM1 channel 3 output/capture input.
				QE11_A	I	MFP12	Quadrature encoder 1 phase A input
				USB_D-	A	MFP14	USB differential signal D-.
23	35	47	87	PA.14	I/O	MFP0	General purpose digital I/O pin.
				I2S0_DI	I	MFP2	I2S0 data input pin.
				UART0_TXD	O	MFP3	UART0 data transmitter output pin.
				SPI2_MISO	I/O	MFP5	SPI2 MISO (Master In, Slave Out) pin.
				I2C2_SCL	I/O	MFP6	I2C2 clock pin.
				SC2_DAT	I/O	MFP7	Smart Card 2 data pin.
				BPWM1_CH4	I/O	MFP11	BPWM1 channel 4 output/capture input.
				QE11_B	I	MFP12	Quadrature encoder 1 phase B input
				USB_D+	A	MFP14	USB differential signal D+.
24	36	48	88	PA.15	I/O	MFP0	General purpose digital I/O pin.
				I2S0_DO	O	MFP2	I2S0 data output pin.
				UART0_RXD	I	MFP3	UART0 data receiver input pin.
				SPI2_MOSI	I/O	MFP5	SPI2 MOSI (Master Out, Slave In) pin.
				I2C2_SDA	I/O	MFP6	I2C2 data input/output pin.
				SC2_CLK	O	MFP7	Smart Card 2 clock pin.
				BPWM1_CH5	I/O	MFP11	BPWM1 channel 5 output/capture input.
				EPWM0_SYNC_IN	I	MFP12	EPWM0 counter synchronous trigger input pin.
				USB_OTG_ID	I	MFP14	USB_ identification.
			89	NC			
			90	V _{DD}	P	MFP0	Power supply for I/O ports and LDO source for internal PLL and digital circuit.
			91	NC			
			92	NC			
			93	VSS	P	MFP0	Ground pin for digital circuit.

32 Pin	48 Pin	64 Pin	128 Pin	Pin Name	Type	MFP	Description
			94	NC			
			95	LDO_CAP	A	MFP0	LDO output pin. Note: This pin needs to be connected with a 1uF capacitor.
			96	NC			
			97	PE.7	I/O	MFP0	General purpose digital I/O pin.
				SD0_CMD	I/O	MFP3	SD/SDIO0 command/response pin
				SPIM_D2	I/O	MFP4	SPIM data 2 pin for Quad Mode I/O.
				UART5_TXD	O	MFP8	UART5 data transmitter output pin.
				CAN1_TXD	O	MFP9	CAN1 bus transmitter output.
				QE11_INDEX	I	MFP11	Quadrature encoder 1 index input
				EPWM0_CH0	I/O	MFP12	EPWM0 channel 0 output/capture input.
				BPWM0_CH5	I/O	MFP13	BPWM0 channel 5 output/capture input.
			98	PE.6	I/O	MFP0	General purpose digital I/O pin.
				SD0_CLK	O	MFP3	SD/SDIO0 clock output pin
				SPIM_D3	I/O	MFP4	SPIM data 3 pin for Quad Mode I/O.
				SPI3_I2SMCLK	I/O	MFP5	SPI3 I2S master clock output pin
				SC0_nCD	I	MFP6	Smart Card 0 card detect pin.
				USCI0_CTL0	I/O	MFP7	USCI0 control 0 pin.
				UART5_RXD	I	MFP8	UART5 data receiver input pin.
				CAN1_RXD	I	MFP9	CAN1 bus receiver input.
				QE11_A	I	MFP11	Quadrature encoder 1 phase A input
				EPWM0_CH1	I/O	MFP12	EPWM0 channel 1 output/capture input.
				BPWM0_CH4	I/O	MFP13	BPWM0 channel 4 output/capture input.
			99	PE.5	I/O	MFP0	General purpose digital I/O pin.
				EBI_nRD	O	MFP2	EBI read enable output pin.
				SD0_DAT3	I/O	MFP3	SD/SDIO0 data line bit 3.
				SPIM_SS	I/O	MFP4	SPIM slave select pin.
				SPI3_SS	I/O	MFP5	SPI3 slave select pin.
				SC0_PWR	O	MFP6	Smart Card 0 power pin.
				USCI0_CTL1	I/O	MFP7	USCI0 control 1 pin.
				QE11_B	I	MFP11	Quadrature encoder 1 phase B input
				EPWM0_CH2	I/O	MFP12	EPWM0 channel 2 output/capture input.
				BPWM0_CH3	I/O	MFP13	BPWM0 channel 3 output/capture input.

32 Pin	48 Pin	64 Pin	128 Pin	Pin Name	Type	MFP	Description
			100	PE.4	I/O	MFP0	General purpose digital I/O pin.
				EBI_nWR	O	MFP2	EBI write enable output pin.
				SD0_DAT2	I/O	MFP3	SD/SDIO0 data line bit 2.
				SPIM_CLK	I/O	MFP4	SPIM serial clock pin.
				SPI3_CLK	I/O	MFP5	SPI3 serial clock pin.
				SC0_RST	O	MFP6	Smart Card 0 reset pin.
				USCI0_DAT1	I/O	MFP7	USCI0 data 1 pin.
				QEI0_INDEX	I	MFP11	Quadrature encoder 0 index input
				EPWM0_CH3	I/O	MFP12	EPWM0 channel 3 output/capture input.
				BPWM0_CH2	I/O	MFP13	BPWM0 channel 2 output/capture input.
			101	PE.3	I/O	MFP0	General purpose digital I/O pin.
				EBI_MCLK	O	MFP2	EBI external clock output pin.
				SD0_DAT1	I/O	MFP3	SD/SDIO0 data line bit 1.
				SPIM_MISO	I/O	MFP4	SPIM MISO (Master In, Slave Out) pin.
				SPI3_MISO	I/O	MFP5	SPI3 MISO (Master In, Slave Out) pin.
				SC0_DAT	I/O	MFP6	Smart Card 0 data pin.
				USCI0_DAT0	I/O	MFP7	USCI0 data 0 pin.
				QEI0_A	I	MFP11	Quadrature encoder 0 phase A input
				EPWM0_CH4	I/O	MFP12	EPWM0 channel 4 output/capture input.
				BPWM0_CH1	I/O	MFP13	BPWM0 channel 1 output/capture input.
			102	PE.2	I/O	MFP0	General purpose digital I/O pin.
				EBI_ALE	O	MFP2	EBI address latch enable output pin.
				SD0_DAT0	I/O	MFP3	SD/SDIO0 data line bit 0.
				SPIM_MOSI	I/O	MFP4	SPIM MOSI (Master Out, Slave In) pin.
				SPI3_MOSI	I/O	MFP5	SPI3 MOSI (Master Out, Slave In) pin.
				SC0_CLK	O	MFP6	Smart Card 0 clock pin.
				USCI0_CLK	I/O	MFP7	USCI0 clock pin.
				QEI0_B	I	MFP11	Quadrature encoder 0 phase B input
				EPWM0_CH5	I/O	MFP12	EPWM0 channel 5 output/capture input.
				BPWM0_CH0	I/O	MFP13	BPWM0 channel 0 output/capture input.
			103	VSS	P	MFP0	Ground pin for digital circuit.
			104	V _{DD}	P	MFP0	Power supply for I/O ports and LDO source for internal PLL and digital circuit.
			105	PE.1	I/O	MFP0	General purpose digital I/O pin.

32 Pin	48 Pin	64 Pin	128 Pin	Pin Name	Type	MFP	Description
				EBI_AD10	I/O	MFP2	EBI address/data bus bit 10.
				QSPI0_MISO0	I/O	MFP3	Quad SPI0 MISO0 (Master In, Slave Out) pin.
				SC2_DAT	I/O	MFP4	Smart Card 2 data pin.
				I2S0_BCLK	O	MFP5	I2S0 bit clock output pin.
				SPI1_MISO	I/O	MFP6	SPI1 MISO (Master In, Slave Out) pin.
				UART3_TXD	O	MFP7	UART3 data transmitter output pin.
				I2C1_SCL	I/O	MFP8	I2C1 clock pin.
				UART4_nCTS	I	MFP9	UART4 clear to Send input pin.
			106	PE.0	I/O	MFP0	General purpose digital I/O pin.
				EBI_AD11	I/O	MFP2	EBI address/data bus bit 11.
				QSPI0_MOSI0	I/O	MFP3	Quad SPI0 MOSI0 (Master Out, Slave In) pin.
				SC2_CLK	O	MFP4	Smart Card 2 clock pin.
				I2S0_MCLK	O	MFP5	I2S0 master clock output pin.
				SPI1_MOSI	I/O	MFP6	SPI1 MOSI (Master Out, Slave In) pin.
				UART3_RXD	I	MFP7	UART3 data receiver input pin.
				I2C1_SDA	I/O	MFP8	I2C1 data input/output pin.
				UART4_nRTS	O	MFP9	UART4 request to Send output pin.
			107	PH.8	I/O	MFP0	General purpose digital I/O pin.
				EBI_AD12	I/O	MFP2	EBI address/data bus bit 12.
				QSPI0_CLK	I/O	MFP3	Quad SPI0 serial clock pin.
				SC2_PWR	O	MFP4	Smart Card 2 power pin.
				I2S0_DI	I	MFP5	I2S0 data input pin.
				SPI1_CLK	I/O	MFP6	SPI1 serial clock pin.
				UART3_nRTS	O	MFP7	UART3 request to Send output pin.
				I2C1_SMBAL	O	MFP8	I2C1 SMBus SMBALTER pin
				I2C2_SCL	I/O	MFP9	I2C2 clock pin.
				UART1_TXD	O	MFP10	UART1 data transmitter output pin.
			108	PH.9	I/O	MFP0	General purpose digital I/O pin.
				EBI_AD13	I/O	MFP2	EBI address/data bus bit 13.
				QSPI0_SS	I/O	MFP3	Quad SPI0 slave select pin.
				SC2_RST	O	MFP4	Smart Card 2 reset pin.
				I2S0_DO	O	MFP5	I2S0 data output pin.
				SPI1_SS	I/O	MFP6	SPI1 slave select pin.

32 Pin	48 Pin	64 Pin	128 Pin	Pin Name	Type	MFP	Description
				UART3_nCTS	I	MFP7	UART3 clear to Send input pin.
				I2C1_SMBUS	O	MFP8	I2C1 SMBus SMBUS pin (PMBus CONTROL pin)
				I2C2_SDA	I/O	MFP9	I2C2 data input/output pin.
				UART1_RXD	I	MFP10	UART1 data receiver input pin.
			109	PH.10	I/O	MFP0	General purpose digital I/O pin.
				EBI_AD14	I/O	MFP2	EBI address/data bus bit 14.
				QSPI0_MISO1	I/O	MFP3	Quad SPI0 MISO1 (Master In, Slave Out) pin.
				SC2_nCD	I	MFP4	Smart Card 2 card detect pin.
				I2S0_LRCK	O	MFP5	I2S0 left right channel clock output pin.
				SPI1_I2SMCLK	I/O	MFP6	SPI1 I2S master clock output pin
				UART4_TXD	O	MFP7	UART4 data transmitter output pin.
				UART0_TXD	O	MFP8	UART0 data transmitter output pin.
			110	PH.11	I/O	MFP0	General purpose digital I/O pin.
				EBI_AD15	I/O	MFP2	EBI address/data bus bit 15.
				QSPI0_MOSI1	I/O	MFP3	Quad SPI0 MOSI1 (Master Out, Slave In) pin.
				UART4_RXD	I	MFP7	UART4 data receiver input pin.
				UART0_RXD	I	MFP8	UART0 data receiver input pin.
				EPWM0_CH5	I/O	MFP11	EPWM0 channel 5 output/capture input.
			111	PD.14	I/O	MFP0	General purpose digital I/O pin.
				EBI_nCS0	O	MFP2	EBI chip select 0 output pin.
				SPI3_I2SMCLK	I/O	MFP3	SPI3 I2S master clock output pin
				SC1_nCD	I	MFP4	Smart Card 1 card detect pin.
				EPWM0_CH4	I/O	MFP11	EPWM0 channel 4 output/capture input.
25	37	49	112	VSS	P	MFP0	Ground pin for digital circuit.
26	38	50	113	LDO_CAP	A	MFP0	LDO output pin.
27	39	51	114	V _{DD}	P	MFP0	Power supply for I/O ports and LDO source for internal PLL and digital circuit.
	40	52	115	PC.14	I/O	MFP0	General purpose digital I/O pin.
				EBI_AD11	I/O	MFP2	EBI address/data bus bit 11.
				SC1_nCD	I	MFP3	Smart Card 1 card detect pin.
				SPI0_I2SMCLK	I/O	MFP4	SPI0 I2S master clock output pin
				USCI0_CTL0	I/O	MFP5	USCI0 control 0 pin.
				QSPI0_CLK	I/O	MFP6	Quad SPI0 serial clock pin.
				EPWM0_SYNC_IN	I	MFP11	EPWM0 counter synchronous trigger input pin.

32 Pin	48 Pin	64 Pin	128 Pin	Pin Name	Type	MFP	Description
				TM1	I/O	MFP13	Timer1 event counter input/toggle output pin.
				USB_VBUS_ST	I	MFP14	USB external VBUS regulator status pin.
28	41	53	116	PB.15	I/O	MFP0	General purpose digital I/O pin.
				EADC0_CH15	A	MFP1	EADC0 channel 15 analog input.
				EBI_AD12	I/O	MFP2	EBI address/data bus bit 12.
				SC1_PWR	O	MFP3	Smart Card 1 power pin.
				SPI0_SS	I/O	MFP4	SPI0 slave select pin.
				USCI0_CTL1	I/O	MFP5	USCI0 control 1 pin.
				UART0_nCTS	I	MFP6	UART0 clear to Send input pin.
				UART3_TXD	O	MFP7	UART3 data transmitter output pin.
				I2C2_SMBAL	O	MFP8	I2C2 SMBus SMBALTER pin
				EPWM1_CH0	I/O	MFP11	EPWM1 channel 0 output/capture input.
				TM0_EXT	I/O	MFP13	Timer0 external capture input/toggle output pin.
				USB_VBUS_EN	O	MFP14	USB external VBUS regulator enable pin.
29	42	54	117	PB.14	I/O	MFP0	General purpose digital I/O pin.
				EADC0_CH14	A	MFP1	EADC0 channel 14 analog input.
				EBI_AD13	I/O	MFP2	EBI address/data bus bit 13.
				SC1_RST	O	MFP3	Smart Card 1 reset pin.
				SPI0_CLK	I/O	MFP4	SPI0 serial clock pin.
				USCI0_DAT1	I/O	MFP5	USCI0 data 1 pin.
				UART0_nRTS	O	MFP6	UART0 request to Send output pin.
				UART3_RXD	I	MFP7	UART3 data receiver input pin.
				I2C2_SMBUS	O	MFP8	I2C2 SMBus SMBUS pin (PMBus CONTROL pin)
				EPWM1_CH1	I/O	MFP11	EPWM1 channel 1 output/capture input.
				TM1_EXT	I/O	MFP13	Timer1 external capture input/toggle output pin.
				CLKO	O	MFP14	Clock Out
30	43	55	118	PB.13	I/O	MFP0	General purpose digital I/O pin.
				EADC0_CH13	A	MFP1	EADC0 channel 13 analog input.
				DAC1_OUT	A	MFP1	DAC1 channel analog output.
				ACMP0_P3	A	MFP1	Analog comparator 0 positive input 3 pin.
				ACMP1_P3	A	MFP1	Analog comparator 1 positive input 3 pin.
				EBI_AD14	I/O	MFP2	EBI address/data bus bit 14.
				SC1_DAT	I/O	MFP3	Smart Card 1 data pin.

32 Pin	48 Pin	64 Pin	128 Pin	Pin Name	Type	MFP	Description
				SPI0_MISO	I/O	MFP4	SPI0 MISO (Master In, Slave Out) pin.
				USCI0_DAT0	I/O	MFP5	USCI0 data 0 pin.
				UART0_TXD	O	MFP6	UART0 data transmitter output pin.
				UART3_nRTS	O	MFP7	UART3 request to Send output pin.
				I2C2_SCL	I/O	MFP8	I2C2 clock pin.
				EPWM1_CH2	I/O	MFP11	EPWM1 channel 2 output/capture input.
				TM2_EXT	I/O	MFP13	Timer2 external capture input/toggle output pin.
31	44	56	119	PB.12	I/O	MFP0	General purpose digital I/O pin.
				EADC0_CH12	A	MFP1	EADC0 channel 12 analog input.
				DAC0_OUT	A	MFP1	DAC0 channel analog output.
				ACMP0_P2	A	MFP1	Analog comparator 0 positive input 2 pin.
				ACMP1_P2	A	MFP1	Analog comparator 1 positive input 2 pin.
				EBI_AD15	I/O	MFP2	EBI address/data bus bit 15.
				SC1_CLK	O	MFP3	Smart Card 1 clock pin.
				SPI0_MOSI	I/O	MFP4	SPI0 MOSI (Master Out, Slave In) pin.
				USCI0_CLK	I/O	MFP5	USCI0 clock pin.
				UART0_RXD	I	MFP6	UART0 data receiver input pin.
				UART3_nCTS	I	MFP7	UART3 clear to Send input pin.
				I2C2_SDA	I/O	MFP8	I2C2 data input/output pin.
				SD0_nCD	I	MFP9	SD/SDIO0 card detect input pin
				EPWM1_CH3	I/O	MFP11	EPWM1 channel 3 output/capture input.
				TM3_EXT	I/O	MFP13	Timer3 external capture input/toggle output pin.
32	45	57	120	AV _{DD}	P	MFP0	Power supply for internal analog circuit.
		58	121	V _{REF}	A	MFP0	ADC reference voltage input. Note: This pin needs to be connected with a 1uF capacitor.
	46	59	122	AVSS	P	MFP0	Ground pin for analog circuit.
		60	123	PB.11	I/O	MFP0	General purpose digital I/O pin.
				EADC0_CH11	A	MFP1	EADC0 channel 11 analog input.
				EBI_ADR16	O	MFP2	EBI address bus bit 16.
				UART0_nCTS	I	MFP5	UART0 clear to Send input pin.
				UART4_TXD	O	MFP6	UART4 data transmitter output pin.
				I2C1_SCL	I/O	MFP7	I2C1 clock pin.
				CAN0_TXD	O	MFP8	CAN0 bus transmitter output.

32 Pin	48 Pin	64 Pin	128 Pin	Pin Name	Type	MFP	Description
				SPI0_I2SMCLK	I/O	MFP9	SPI0 I2S master clock output pin
				BPWM1_CH0	I/O	MFP10	BPWM1 channel 0 output/capture input.
				SPI3_CLK	I/O	MFP11	SPI3 serial clock pin.
		61	124	PB.10	I/O	MFP0	General purpose digital I/O pin.
				EADC0_CH10	A	MFP1	EADC0 channel 10 analog input.
				EBI_ADR17	O	MFP2	EBI address bus bit 17.
				USCI1_CTL0	I/O	MFP4	USCI1 control 0 pin.
				UART0_nRTS	O	MFP5	UART0 request to Send output pin.
				UART4_RXD	I	MFP6	UART4 data receiver input pin.
				I2C1_SDA	I/O	MFP7	I2C1 data input/output pin.
				CAN0_RXD	I	MFP8	CAN0 bus receiver input.
				BPWM1_CH1	I/O	MFP10	BPWM1 channel 1 output/capture input.
				SPI3_SS	I/O	MFP11	SPI3 slave select pin.
		62	125	PB.9	I/O	MFP0	General purpose digital I/O pin.
				EADC0_CH9	A	MFP1	EADC0 channel 9 analog input.
				EBI_ADR18	O	MFP2	EBI address bus bit 18.
				USCI1_CTL1	I/O	MFP4	USCI1 control 1 pin.
				UART0_TXD	O	MFP5	UART0 data transmitter output pin.
				UART1_nCTS	I	MFP6	UART1 clear to Send input pin.
				I2C1_SMBAL	O	MFP7	I2C1 SMBus SMBALTER pin
				BPWM1_CH2	I/O	MFP10	BPWM1 channel 2 output/capture input.
				SPI3_MISO	I/O	MFP11	SPI3 MISO (Master In, Slave Out) pin.
				INT7	I	MFP13	External interrupt 7 input pin.
		63	126	PB.8	I/O	MFP0	General purpose digital I/O pin.
				EADC0_CH8	A	MFP1	EADC0 channel 8 analog input.
				EBI_ADR19	O	MFP2	EBI address bus bit 19.
				USCI1_CLK	I/O	MFP4	USCI1 clock pin.
				UART0_RXD	I	MFP5	UART0 data receiver input pin.
				UART1_nRTS	O	MFP6	UART1 request to Send output pin.
				I2C1_SMBUS	O	MFP7	I2C1 SMBus SMBUS pin (PMBus CONTROL pin)
				BPWM1_CH3	I/O	MFP10	BPWM1 channel 3 output/capture input.
				SPI3_MOSI	I/O	MFP11	SPI3 MOSI (Master Out, Slave In) pin.
				INT6	I	MFP13	External interrupt 6 input pin.

32 Pin	48 Pin	64 Pin	128 Pin	Pin Name	Type	MFP	Description
	47	64	127	PB.7	I/O	MFP0	General purpose digital I/O pin.
				EADC0_CH7	A	MFP1	EADC0 channel 7 analog input.
				EBI_nWRL	O	MFP2	EBI low byte write enable output pin.
				USCI1_DAT0	I/O	MFP4	USCI1 data 0 pin.
				CAN1_TXD	O	MFP5	CAN1 bus transmitter output.
				UART1_TXD	O	MFP6	UART1 data transmitter output pin.
				SD1_CMD	I/O	MFP7	SD/SDIO1 command/response pin
				EBI_nCS0	O	MFP8	EBI chip select 0 output pin.
				BPWM1_CH4	I/O	MFP10	BPWM1 channel 4 output/capture input.
				EPWM1_BRAKE0	I	MFP11	EPWM1 Brake 0 input pin.
				EPWM1_CH4	I/O	MFP12	EPWM1 channel 4 output/capture input.
				INT5	I	MFP13	External interrupt 5 input pin.
				USB_VBUS_ST	I	MFP14	USB external VBUS regulator status pin.
				ACMP0_O	O	MFP15	Analog comparator 0 output pin.
	48	1	128	PB.6	I/O	MFP0	General purpose digital I/O pin.
				EADC0_CH6	A	MFP1	EADC0 channel 6 analog input.
				EBI_nWRH	O	MFP2	EBI high byte write enable output pin
				USCI1_DAT1	I/O	MFP4	USCI1 data 1 pin.
				CAN1_RXD	I	MFP5	CAN1 bus receiver input.
				UART1_RXD	I	MFP6	UART1 data receiver input pin.
				SD1_CLK	O	MFP7	SD/SDIO1 clock output pin
				EBI_nCS1	O	MFP8	EBI chip select 1 output pin.
				BPWM1_CH5	I/O	MFP10	BPWM1 channel 5 output/capture input.
				EPWM1_BRAKE1	I	MFP11	EPWM1 Brake 1 input pin.
				EPWM1_CH5	I/O	MFP12	EPWM1 channel 5 output/capture input.
				INT4	I	MFP13	External interrupt 4 input pin.
				USB_VBUS_EN	O	MFP14	USB external VBUS regulator enable pin.
				ACMP1_O	O	MFP15	Analog comparator 1 output pin.

4.2.3 M483 Series Pin Description

64 Pin	128 Pin	Pin Name	Type	MFP	Description
2	1	PB.5	I/O	MFP0	General purpose digital I/O pin.
		EADC0_CH5	A	MFP1	EADC0 channel 5 analog input.
		ACMP1_N	A	MFP1	Analog comparator 1 negative input pin.
		EBI_ADR0	O	MFP2	EBI address bus bit 0.
		SD0_DAT3	I/O	MFP3	SD/SDIO0 data line bit 3.
		SPI1_MISO	I/O	MFP5	SPI1 MISO (Master In, Slave Out) pin.
		I2C0_SCL	I/O	MFP6	I2C0 clock pin.
		UART5_TXD	O	MFP7	UART5 data transmitter output pin.
		USCI1_CTL0	I/O	MFP8	USCI1 control 0 pin.
		SC0_CLK	O	MFP9	Smart Card 0 clock pin.
		I2S0_BCLK	O	MFP10	I2S0 bit clock output pin.
		EPWM0_CH0	I/O	MFP11	EPWM0 channel 0 output/capture input.
		TM0	I/O	MFP14	Timer0 event counter input/toggle output pin.
		INT0	I	MFP15	External interrupt 0 input pin.
3	2	PB.4	I/O	MFP0	General purpose digital I/O pin.
		EADC0_CH4	A	MFP1	EADC0 channel 4 analog input.
		ACMP1_P1	A	MFP1	Analog comparator 1 positive input 1 pin.
		EBI_ADR1	O	MFP2	EBI address bus bit 1.
		SD0_DAT2	I/O	MFP3	SD/SDIO0 data line bit 2.
		SPI1_MOSI	I/O	MFP5	SPI1 MOSI (Master Out, Slave In) pin.
		I2C0_SDA	I/O	MFP6	I2C0 data input/output pin.
		UART5_RXD	I	MFP7	UART5 data receiver input pin.
		USCI1_CTL1	I/O	MFP8	USCI1 control 1 pin.
		SC0_DAT	I/O	MFP9	Smart Card 0 data pin.
		I2S0_MCLK	O	MFP10	I2S0 master clock output pin.
		EPWM0_CH1	I/O	MFP11	EPWM0 channel 1 output/capture input.
		TM1	I/O	MFP14	Timer1 event counter input/toggle output pin.
		INT1	I	MFP15	External interrupt 1 input pin.
4	3	PB.3	I/O	MFP0	General purpose digital I/O pin.
		EADC0_CH3	A	MFP1	EADC0 channel 3 analog input.
		ACMP0_N	A	MFP1	Analog comparator 0 negative input pin.
		EBI_ADR2	O	MFP2	EBI address bus bit 2.
		SD0_DAT1	I/O	MFP3	SD/SDIO0 data line bit 1.

64 Pin	128 Pin	Pin Name	Type	MFP	Description
		SPI1_CLK	I/O	MFP5	SPI1 serial clock pin.
		UART1_TXD	O	MFP6	UART1 data transmitter output pin.
		UART5_nRTS	O	MFP7	UART5 request to Send output pin.
		USCI1_DAT1	I/O	MFP8	USCI1 data 1 pin.
		SC0_RST	O	MFP9	Smart Card 0 reset pin.
		I2S0_DI	I	MFP10	I2S0 data input pin.
		EPWM0_CH2	I/O	MFP11	EPWM0 channel 2 output/capture input.
		TM2	I/O	MFP14	Timer2 event counter input/toggle output pin.
		INT2	I	MFP15	External interrupt 2 input pin.
5	4	PB.2	I/O	MFP0	General purpose digital I/O pin.
		EADC0_CH2	A	MFP1	EADC0 channel 2 analog input.
		ACMP0_P1	A	MFP1	Analog comparator 0 positive input 1 pin.
		OPA0_O	A	MFP1	Operational amplifier 0 output pin.
		EBI_ADR3	O	MFP2	EBI address bus bit 3.
		SD0_DAT0	I/O	MFP3	SD/SDIO0 data line bit 0.
		SPI1_SS	I/O	MFP5	SPI1 slave select pin.
		UART1_RXD	I	MFP6	UART1 data receiver input pin.
		UART5_nCTS	I	MFP7	UART5 clear to Send input pin.
		USCI1_DAT0	I/O	MFP8	USCI1 data 0 pin.
		SC0_PWR	O	MFP9	Smart Card 0 power pin.
		I2S0_DO	O	MFP10	I2S0 data output pin.
		EPWM0_CH3	I/O	MFP11	EPWM0 channel 3 output/capture input.
		TM3	I/O	MFP14	Timer3 event counter input/toggle output pin.
		INT3	I	MFP15	External interrupt 3 input pin.
	5	PC.12	I/O	MFP0	General purpose digital I/O pin.
		EBI_ADR4	O	MFP2	EBI address bus bit 4.
		UART0_TXD	O	MFP3	UART0 data transmitter output pin.
		I2C0_SCL	I/O	MFP4	I2C0 clock pin.
		SPI3_MISO	I/O	MFP6	SPI3 MISO (Master In, Slave Out) pin.
		SC0_nCD	I	MFP9	Smart Card 0 card detect pin.
		ECAP1_IC2	I	MFP11	Enhanced capture unit 1 input 2 pin.
		EPWM1_CH0	I/O	MFP12	EPWM1 channel 0 output/capture input.
		ACMP0_O	O	MFP14	Analog comparator 0 output pin.
	6	PC.11	I/O	MFP0	General purpose digital I/O pin.

64 Pin	128 Pin	Pin Name	Type	MFP	Description
		EBI_ADR5	O	MFP2	EBI address bus bit 5.
		UART0_RXD	I	MFP3	UART0 data receiver input pin.
		I2C0_SDA	I/O	MFP4	I2C0 data input/output pin.
		SPI3_MOSI	I/O	MFP6	SPI3 MOSI (Master Out, Slave In) pin.
		ECAP1_IC1	I	MFP11	Enhanced capture unit 1 input 1 pin.
		EPWM1_CH1	I/O	MFP12	EPWM1 channel 1 output/capture input.
		ACMP1_O	O	MFP14	Analog comparator 1 output pin.
	7	PC.10	I/O	MFP0	General purpose digital I/O pin.
		EBI_ADR6	O	MFP2	EBI address bus bit 6.
		SPI3_CLK	I/O	MFP6	SPI3 serial clock pin.
		UART3_TXD	O	MFP7	UART3 data transmitter output pin.
		CAN1_TXD	O	MFP9	CAN1 bus transmitter output.
		ECAP1_IC0	I	MFP11	Enhanced capture unit 1 input 0 pin.
		EPWM1_CH2	I/O	MFP12	EPWM1 channel 2 output/capture input.
	8	PC.9	I/O	MFP0	General purpose digital I/O pin.
		EBI_ADR7	O	MFP2	EBI address bus bit 7.
		SPI3_SS	I/O	MFP6	SPI3 slave select pin.
		UART3_RXD	I	MFP7	UART3 data receiver input pin.
		CAN1_RXD	I	MFP9	CAN1 bus receiver input.
		EPWM1_CH3	I/O	MFP12	EPWM1 channel 3 output/capture input.
6	9	PB.1	I/O	MFP0	General purpose digital I/O pin.
		EADC0_CH1	A	MFP1	EADC0 channel 1 analog input.
		OPA0_N	A	MFP1	Operational amplifier 0 negative input pin.
		EBI_ADR8	O	MFP2	EBI address bus bit 8.
		SD0_CLK	O	MFP3	SD/SDIO0 clock output pin
		SPI1_I2SMCLK	I/O	MFP5	SPI1 I2S master clock output pin
		SPI3_I2SMCLK	I/O	MFP6	SPI3 I2S master clock output pin
		UART2_TXD	O	MFP7	UART2 data transmitter output pin.
		USC1_CLK	I/O	MFP8	USC1 clock pin.
		I2C1_SCL	I/O	MFP9	I2C1 clock pin.
		I2S0_LRCK	O	MFP10	I2S0 left right channel clock output pin.
		EPWM0_CH4	I/O	MFP11	EPWM0 channel 4 output/capture input.
		EPWM1_CH4	I/O	MFP12	EPWM1 channel 4 output/capture input.
		EPWM0_BRAKE0	I	MFP13	EPWM0 Brake 0 input pin.

64 Pin	128 Pin	Pin Name	Type	MFP	Description
7	10	PB.0	I/O	MFP0	General purpose digital I/O pin.
		EADC0_CH0	A	MFP1	EADC0 channel 0 analog input.
		OPA0_P	A	MFP1	Operational amplifier 0 positive input pin.
		EBI_ADR9	O	MFP2	EBI address bus bit 9.
		SD0_CMD	I/O	MFP3	SD/SDIO0 command/response pin
		UART2_RXD	I	MFP7	UART2 data receiver input pin.
		SPI0_I2SMCLK	I/O	MFP8	SPI0 I2S master clock output pin
		I2C1_SDA	I/O	MFP9	I2C1 data input/output pin.
		EPWM0_CH5	I/O	MFP11	EPWM0 channel 5 output/capture input.
		EPWM1_CH5	I/O	MFP12	EPWM1 channel 5 output/capture input.
		EPWM0_BRAKE1	I	MFP13	EPWM0 Brake 1 input pin.
	11	V _{SS}	P	MFP0	Ground pin for digital circuit.
	12	V _{DD}	P	MFP0	Power supply for I/O ports and LDO source for internal PLL and digital circuit.
8	13	PA.11	I/O	MFP0	General purpose digital I/O pin.
		ACMP0_P0	A	MFP1	Analog comparator 0 positive input 0 pin.
		EBI_nRD	O	MFP2	EBI read enable output pin.
		SC2_PWR	O	MFP3	Smart Card 2 power pin.
		SPI2_SS	I/O	MFP4	SPI2 slave select pin.
		SD1_DAT3	I/O	MFP5	SD/SDIO1 data line bit 3.
		USCI0_CLK	I/O	MFP6	USCI0 clock pin.
		I2C2_SCL	I/O	MFP7	I2C2 clock pin.
		BPWM0_CH0	I/O	MFP9	BPWM0 channel 0 output/capture input.
		EPWM0_SYNC_OUT	O	MFP10	EPWM0 counter synchronous trigger output pin.
		TM0_EXT	I/O	MFP13	Timer0 external capture input/toggle output pin.
				DAC1_ST	I
9	14	PA.10	I/O	MFP0	General purpose digital I/O pin.
		ACMP1_P0	A	MFP1	Analog comparator 1 positive input 0 pin.
		OPA1_O	A	MFP1	Operational amplifier 1 output pin.
		EBI_nWR	O	MFP2	EBI write enable output pin.
		SC2_RST	O	MFP3	Smart Card 2 reset pin.
		SPI2_CLK	I/O	MFP4	SPI2 serial clock pin.
		SD1_DAT2	I/O	MFP5	SD/SDIO1 data line bit 2.
				USCI0_DAT0	I/O

64 Pin	128 Pin	Pin Name	Type	MFP	Description
		I2C2_SDA	I/O	MFP7	I2C2 data input/output pin.
		BPWM0_CH1	I/O	MFP9	BPWM0 channel 1 output/capture input.
		QE11_INDEX	I	MFP10	Quadrature encoder 1 index input
		ECAP0_IC0	I	MFP11	Enhanced capture unit 0 input 0 pin.
		TM1_EXT	I/O	MFP13	Timer1 external capture input/toggle output pin.
		DAC0_ST	I	MFP14	DAC0 external trigger input.
10	15	PA.9	I/O	MFP0	General purpose digital I/O pin.
		OPA1_N	A	MFP1	Operational amplifier 1 negative input pin.
		EBI_MCLK	O	MFP2	EBI external clock output pin.
		SC2_DAT	I/O	MFP3	Smart Card 2 data pin.
		SPI2_MISO	I/O	MFP4	SPI2 MISO (Master In, Slave Out) pin.
		SD1_DAT1	I/O	MFP5	SD/SDIO1 data line bit 1.
		USCI0_DAT1	I/O	MFP6	USCI0 data 1 pin.
		UART1_TXD	O	MFP7	UART1 data transmitter output pin.
		BPWM0_CH2	I/O	MFP9	BPWM0 channel 2 output/capture input.
		QE11_A	I	MFP10	Quadrature encoder 1 phase A input
		ECAP0_IC1	I	MFP11	Enhanced capture unit 0 input 1 pin.
		TM2_EXT	I/O	MFP13	Timer2 external capture input/toggle output pin.
11	16	PA.8	I/O	MFP0	General purpose digital I/O pin.
		OPA1_P	A	MFP1	Operational amplifier 1 positive input pin.
		EBI_ALE	O	MFP2	EBI address latch enable output pin.
		SC2_CLK	O	MFP3	Smart Card 2 clock pin.
		SPI2_MOSI	I/O	MFP4	SPI2 MOSI (Master Out, Slave In) pin.
		SD1_DAT0	I/O	MFP5	SD/SDIO1 data line bit 0.
		USCI0_CTL1	I/O	MFP6	USCI0 control 1 pin.
		UART1_RXD	I	MFP7	UART1 data receiver input pin.
		BPWM0_CH3	I/O	MFP9	BPWM0 channel 3 output/capture input.
		QE11_B	I	MFP10	Quadrature encoder 1 phase B input
		ECAP0_IC2	I	MFP11	Enhanced capture unit 0 input 2 pin.
		TM3_EXT	I/O	MFP13	Timer3 external capture input/toggle output pin.
		INT4	I	MFP15	External interrupt 4 input pin.
	17	PC.13	I/O	MFP0	General purpose digital I/O pin.
		EBI_ADR10	O	MFP2	EBI address bus bit 10.
		SC2_nCD	I	MFP3	Smart Card 2 card detect pin.

64 Pin	128 Pin	Pin Name	Type	MFP	Description
		SPI2_I2SMCLK	I/O	MFP4	SPI2 I2S master clock output pin
		CAN1_TXD	O	MFP5	CAN1 bus transmitter output.
		USCI0_CTL0	I/O	MFP6	USCI0 control 0 pin.
		UART2_TXD	O	MFP7	UART2 data transmitter output pin.
		BPWM0_CH4	I/O	MFP9	BPWM0 channel 4 output/capture input.
		CLKO	O	MFP13	Clock Out
		EADC0_ST	I	MFP14	EADC0 external trigger input.
	18	PD.12	I/O	MFP0	General purpose digital I/O pin.
		OPA2_O	A	MFP1	Operational amplifier 2 output pin.
		EBI_nCS0	O	MFP2	EBI chip select 0 output pin.
		CAN1_RXD	I	MFP5	CAN1 bus receiver input.
		UART2_RXD	I	MFP7	UART2 data receiver input pin.
		BPWM0_CH5	I/O	MFP9	BPWM0 channel 5 output/capture input.
		QEIO_INDEX	I	MFP10	Quadrature encoder 0 index input
		CLKO	O	MFP13	Clock Out
		EADC0_ST	I	MFP14	EADC0 external trigger input.
		INT5	I	MFP15	External interrupt 5 input pin.
	19	PD.11	I/O	MFP0	General purpose digital I/O pin.
		OPA2_N	A	MFP1	Operational amplifier 2 negative input pin.
		EBI_nCS1	O	MFP2	EBI chip select 1 output pin.
		UART1_TXD	O	MFP3	UART1 data transmitter output pin.
		CAN0_TXD	O	MFP4	CAN0 bus transmitter output.
		QEIO_A	I	MFP10	Quadrature encoder 0 phase A input
		INT6	I	MFP15	External interrupt 6 input pin.
	20	PD.10	I/O	MFP0	General purpose digital I/O pin.
		OPA2_P	A	MFP1	Operational amplifier 2 positive input pin.
		EBI_nCS2	O	MFP2	EBI chip select 2 output pin.
		UART1_RXD	I	MFP3	UART1 data receiver input pin.
		CAN0_RXD	I	MFP4	CAN0 bus receiver input.
		QEIO_B	I	MFP10	Quadrature encoder 0 phase B input
		INT7	I	MFP15	External interrupt 7 input pin.
	21	PG.2	I/O	MFP0	General purpose digital I/O pin.
		EBI_ADR11	O	MFP2	EBI address bus bit 11.
		SPI2_SS	I/O	MFP3	SPI2 slave select pin.

64 Pin	128 Pin	Pin Name	Type	MFP	Description
		I2C0_SMBAL	O	MFP4	I2C0 SMBus SMBALTER pin
		I2C1_SCL	I/O	MFP5	I2C1 clock pin.
		TM0	I/O	MFP13	Timer0 event counter input/toggle output pin.
	22	PG.3	I/O	MFP0	General purpose digital I/O pin.
		EBI_ADR12	O	MFP2	EBI address bus bit 12.
		SPI2_CLK	I/O	MFP3	SPI2 serial clock pin.
		I2C0_SMBUSUS	O	MFP4	I2C0 SMBus SMBSUS pin (PMBus CONTROL pin)
		I2C1_SDA	I/O	MFP5	I2C1 data input/output pin.
		TM1	I/O	MFP13	Timer1 event counter input/toggle output pin.
	23	PG.4	I/O	MFP0	General purpose digital I/O pin.
		EBI_ADR13	O	MFP2	EBI address bus bit 13.
		SPI2_MISO	I/O	MFP3	SPI2 MISO (Master In, Slave Out) pin.
		TM2	I/O	MFP13	Timer2 event counter input/toggle output pin.
	24	PF.11	I/O	MFP0	General purpose digital I/O pin.
		EBI_ADR14	O	MFP2	EBI address bus bit 14.
		SPI2_MOSI	I/O	MFP3	SPI2 MOSI (Master Out, Slave In) pin.
		TAMPER5	I/O	MFP10	TAMPER detector loop pin 5.
		TM3	I/O	MFP13	Timer3 event counter input/toggle output pin.
	25	PF.10	I/O	MFP0	General purpose digital I/O pin.
		EBI_ADR15	O	MFP2	EBI address bus bit 15.
		SC0_nCD	I	MFP3	Smart Card 0 card detect pin.
		I2S0_BCLK	O	MFP4	I2S0 bit clock output pin.
		SPI0_I2SMCLK	I/O	MFP5	SPI0 I2S master clock output pin
		TAMPER4	I/O	MFP10	TAMPER detector loop pin 4.
	26	PF.9	I/O	MFP0	General purpose digital I/O pin.
		EBI_ADR16	O	MFP2	EBI address bus bit 16.
		SC0_PWR	O	MFP3	Smart Card 0 power pin.
		I2S0_MCLK	O	MFP4	I2S0 master clock output pin.
		SPI0_SS	I/O	MFP5	SPI0 slave select pin.
		TAMPER3	I/O	MFP10	TAMPER detector loop pin 3.
	27	PF.8	I/O	MFP0	General purpose digital I/O pin.
		EBI_ADR17	O	MFP2	EBI address bus bit 17.
		SC0_RST	O	MFP3	Smart Card 0 reset pin.
		I2S0_DI	I	MFP4	I2S0 data input pin.

64 Pin	128 Pin	Pin Name	Type	MFP	Description
		SPI0_CLK	I/O	MFP5	SPI0 serial clock pin.
		TAMPER2	I/O	MFP10	TAMPER detector loop pin 2.
	28	PF.7	I/O	MFP0	General purpose digital I/O pin.
		EBI_ADR18	O	MFP2	EBI address bus bit 18.
		SC0_DAT	I/O	MFP3	Smart Card 0 data pin.
		I2S0_DO	O	MFP4	I2S0 data output pin.
		SPI0_MISO	I/O	MFP5	SPI0 MISO (Master In, Slave Out) pin.
		UART4_TXD	O	MFP6	UART4 data transmitter output pin.
		TAMPER1	I/O	MFP10	TAMPER detector loop pin 1.
12	29	PF.6	I/O	MFP0	General purpose digital I/O pin.
		EBI_ADR19	O	MFP2	EBI address bus bit 19.
		SC0_CLK	O	MFP3	Smart Card 0 clock pin.
		I2S0_LRCK	O	MFP4	I2S0 left right channel clock output pin.
		SPI0_MOSI	I/O	MFP5	SPI0 MOSI (Master Out, Slave In) pin.
		UART4_RXD	I	MFP6	UART4 data receiver input pin.
		EBI_nCS0	O	MFP7	EBI chip select 0 output pin.
		TAMPER0	I/O	MFP10	TAMPER detector loop pin 0.
13	30	V _{DD}	P	MFP0	Power supply for I/O ports and LDO source for internal PLL and digital circuit.
14	31	PF.5	I/O	MFP0	General purpose digital I/O pin.
		UART2_RXD	I	MFP2	UART2 data receiver input pin.
		UART2_nCTS	I	MFP4	UART2 clear to Send input pin.
		BPWM0_CH4	I/O	MFP8	BPWM0 channel 4 output/capture input.
		EPWM0_SYNC_OUT	O	MFP9	EPWM0 counter synchronous trigger output pin.
		X32_IN	I	MFP10	External 32.768 kHz crystal input pin.
		EADC0_ST	I	MFP11	EADC0 external trigger input.
15	32	PF.4	I/O	MFP0	General purpose digital I/O pin.
		UART2_TXD	O	MFP2	UART2 data transmitter output pin.
		UART2_nRTS	O	MFP4	UART2 request to Send output pin.
		BPWM0_CH5	I/O	MFP8	BPWM0 channel 5 output/capture input.
		X32_OUT	O	MFP10	External 32.768 kHz crystal output pin.
	33	PH.4	I/O	MFP0	General purpose digital I/O pin.
		EBI_ADR3	O	MFP2	EBI address bus bit 3.
		SPI1_MISO	I/O	MFP3	SPI1 MISO (Master In, Slave Out) pin.

64 Pin	128 Pin	Pin Name	Type	MFP	Description
	34	PH.5	I/O	MFP0	General purpose digital I/O pin.
		EBI_ADR2	O	MFP2	EBI address bus bit 2.
		SPI1_MOSI	I/O	MFP3	SPI1 MOSI (Master Out, Slave In) pin.
	35	PH.6	I/O	MFP0	General purpose digital I/O pin.
		EBI_ADR1	O	MFP2	EBI address bus bit 1.
		SPI1_CLK	I/O	MFP3	SPI1 serial clock pin.
	36	PH.7	I/O	MFP0	General purpose digital I/O pin.
		EBI_ADR0	O	MFP2	EBI address bus bit 0.
		SPI1_SS	I/O	MFP3	SPI1 slave select pin.
16	37	PF.3	I/O	MFP0	General purpose digital I/O pin.
		EBI_nCS0	O	MFP2	EBI chip select 0 output pin.
		UART0_TXD	O	MFP3	UART0 data transmitter output pin.
		I2C0_SCL	I/O	MFP4	I2C0 clock pin.
		XT1_IN	I	MFP10	External 4~24 MHz (high speed) crystal input pin.
		BPWM1_CH0	I/O	MFP11	BPWM1 channel 0 output/capture input.
17	38	PF.2	I/O	MFP0	General purpose digital I/O pin.
		EBI_nCS1	O	MFP2	EBI chip select 1 output pin.
		UART0_RXD	I	MFP3	UART0 data receiver input pin.
		I2C0_SDA	I/O	MFP4	I2C0 data input/output pin.
		QSPI0_CLK	I/O	MFP5	Quad SPI0 serial clock pin.
		XT1_OUT	O	MFP10	External 4~24 MHz (high speed) crystal output pin.
		BPWM1_CH1	I/O	MFP11	BPWM1 channel 1 output/capture input.
	39	V _{SS}	P	MFP0	Ground pin for digital circuit.
	40	V _{DD}	P	MFP0	Power supply for I/O ports and LDO source for internal PLL and digital circuit.
	41	PE.8	I/O	MFP0	General purpose digital I/O pin.
		EBI_ADR10	O	MFP2	EBI address bus bit 10.
		I2S0_BCLK	O	MFP4	I2S0 bit clock output pin.
		SPI2_CLK	I/O	MFP5	SPI2 serial clock pin.
		USC11_CTL1	I/O	MFP6	USC11 control 1 pin.
		UART2_TXD	O	MFP7	UART2 data transmitter output pin.
		EPWM0_CH0	I/O	MFP10	EPWM0 channel 0 output/capture input.
		EPWM0_BRAKE0	I	MFP11	EPWM0 Brake 0 input pin.
		ECAP0_IC0	I	MFP12	Enhanced capture unit 0 input 0 pin.

64 Pin	128 Pin	Pin Name	Type	MFP	Description
		TRACE_CLK	O	MFP14	ETM Trace Clock output pin
	42	PE.9	I/O	MFP0	General purpose digital I/O pin.
		EBI_ADR11	O	MFP2	EBI address bus bit 11.
		I2S0_MCLK	O	MFP4	I2S0 master clock output pin.
		SPI2_MISO	I/O	MFP5	SPI2 MISO (Master In, Slave Out) pin.
		USCI1_CTL0	I/O	MFP6	USCI1 control 0 pin.
		UART2_RXD	I	MFP7	UART2 data receiver input pin.
		EPWM0_CH1	I/O	MFP10	EPWM0 channel 1 output/capture input.
		EPWM0_BRAKE1	I	MFP11	EPWM0 Brake 1 input pin.
		ECAP0_IC1	I	MFP12	Enhanced capture unit 0 input 1 pin.
		TRACE_DATA0	O	MFP14	ETM Trace Data 0 output pin
	43	PE.10	I/O	MFP0	General purpose digital I/O pin.
		EBI_ADR12	O	MFP2	EBI address bus bit 12.
		I2S0_DI	I	MFP4	I2S0 data input pin.
		SPI2_MOSI	I/O	MFP5	SPI2 MOSI (Master Out, Slave In) pin.
		USCI1_DAT0	I/O	MFP6	USCI1 data 0 pin.
		UART3_TXD	O	MFP7	UART3 data transmitter output pin.
		EPWM0_CH2	I/O	MFP10	EPWM0 channel 2 output/capture input.
		EPWM1_BRAKE0	I	MFP11	EPWM1 Brake 0 input pin.
		ECAP0_IC2	I	MFP12	Enhanced capture unit 0 input 2 pin.
		TRACE_DATA1	O	MFP14	ETM Trace Data 1 output pin
	44	PE.11	I/O	MFP0	General purpose digital I/O pin.
		EBI_ADR13	O	MFP2	EBI address bus bit 13.
		I2S0_DO	O	MFP4	I2S0 data output pin.
		SPI2_SS	I/O	MFP5	SPI2 slave select pin.
		USCI1_DAT1	I/O	MFP6	USCI1 data 1 pin.
		UART3_RXD	I	MFP7	UART3 data receiver input pin.
		UART1_nCTS	I	MFP8	UART1 clear to Send input pin.
		EPWM0_CH3	I/O	MFP10	EPWM0 channel 3 output/capture input.
		EPWM1_BRAKE1	I	MFP11	EPWM1 Brake 1 input pin.
		ECAP1_IC2	I	MFP13	Enhanced capture unit 1 input 2 pin.
	TRACE_DATA2	O	MFP14	ETM Trace Data 2 output pin	
	45	PE.12	I/O	MFP0	General purpose digital I/O pin.
		EBI_ADR14	O	MFP2	EBI address bus bit 14.

64 Pin	128 Pin	Pin Name	Type	MFP	Description
		I2S0_LRCK	O	MFP4	I2S0 left right channel clock output pin.
		SPI2_I2SMCLK	I/O	MFP5	SPI2 I2S master clock output pin
		USCI1_CLK	I/O	MFP6	USCI1 clock pin.
		UART1_nRTS	O	MFP8	UART1 request to Send output pin.
		EPWM0_CH4	I/O	MFP10	EPWM0 channel 4 output/capture input.
		ECAP1_IC1	I	MFP13	Enhanced capture unit 1 input 1 pin.
		TRACE_DATA3	O	MFP14	ETM Trace Data 3 output pin
	46	PE.13	I/O	MFP0	General purpose digital I/O pin.
		EBI_ADR15	O	MFP2	EBI address bus bit 15.
		I2C0_SCL	I/O	MFP4	I2C0 clock pin.
		UART4_nRTS	O	MFP5	UART4 request to Send output pin.
		UART1_TXD	O	MFP8	UART1 data transmitter output pin.
		EPWM0_CH5	I/O	MFP10	EPWM0 channel 5 output/capture input.
		EPWM1_CH0	I/O	MFP11	EPWM1 channel 0 output/capture input.
		BPWM1_CH5	I/O	MFP12	BPWM1 channel 5 output/capture input.
		ECAP1_IC0	I	MFP13	Enhanced capture unit 1 input 0 pin.
	47	PC.8	I/O	MFP0	General purpose digital I/O pin.
		EBI_ADR16	O	MFP2	EBI address bus bit 16.
		I2C0_SDA	I/O	MFP4	I2C0 data input/output pin.
		UART4_nCTS	I	MFP5	UART4 clear to Send input pin.
		UART1_RXD	I	MFP8	UART1 data receiver input pin.
		EPWM1_CH1	I/O	MFP11	EPWM1 channel 1 output/capture input.
		BPWM1_CH4	I/O	MFP12	BPWM1 channel 4 output/capture input.
18	48	PC.7	I/O	MFP0	General purpose digital I/O pin.
		EBI_AD9	I/O	MFP2	EBI address/data bus bit 9.
		SPI1_MISO	I/O	MFP4	SPI1 MISO (Master In, Slave Out) pin.
		UART4_TXD	O	MFP5	UART4 data transmitter output pin.
		SC2_PWR	O	MFP6	Smart Card 2 power pin.
		UART0_nCTS	I	MFP7	UART0 clear to Send input pin.
		I2C1_SMBAL	O	MFP8	I2C1 SMBus SMBALTER pin
		EPWM1_CH2	I/O	MFP11	EPWM1 channel 2 output/capture input.
		BPWM1_CH0	I/O	MFP12	BPWM1 channel 0 output/capture input.
		TM0	I/O	MFP14	Timer0 event counter input/toggle output pin.
		INT3	I	MFP15	External interrupt 3 input pin.

64 Pin	128 Pin	Pin Name	Type	MFP	Description
19	49	PC.6	I/O	MFP0	General purpose digital I/O pin.
		EBI_AD8	I/O	MFP2	EBI address/data bus bit 8.
		SPI1_MOSI	I/O	MFP4	SPI1 MOSI (Master Out, Slave In) pin.
		UART4_RXD	I	MFP5	UART4 data receiver input pin.
		SC2_RST	O	MFP6	Smart Card 2 reset pin.
		UART0_nRTS	O	MFP7	UART0 request to Send output pin.
		I2C1_SMBSUS	O	MFP8	I2C1 SMBus SMBSUS pin (PMBus CONTROL pin)
		EPWM1_CH3	I/O	MFP11	EPWM1 channel 3 output/capture input.
		BPWM1_CH1	I/O	MFP12	BPWM1 channel 1 output/capture input.
		TM1	I/O	MFP14	Timer1 event counter input/toggle output pin.
		INT2	I	MFP15	External interrupt 2 input pin.
20	50	PA.7	I/O	MFP0	General purpose digital I/O pin.
		EBI_AD7	I/O	MFP2	EBI address/data bus bit 7.
		SPI1_CLK	I/O	MFP4	SPI1 serial clock pin.
		SC2_DAT	I/O	MFP6	Smart Card 2 data pin.
		UART0_TXD	O	MFP7	UART0 data transmitter output pin.
		I2C1_SCL	I/O	MFP8	I2C1 clock pin.
		EPWM1_CH4	I/O	MFP11	EPWM1 channel 4 output/capture input.
		BPWM1_CH2	I/O	MFP12	BPWM1 channel 2 output/capture input.
		ACMP0_WLAT	I	MFP13	Analog comparator 0 window latch input pin
		TM2	I/O	MFP14	Timer2 event counter input/toggle output pin.
		INT1	I	MFP15	External interrupt 1 input pin.
21	51	PA.6	I/O	MFP0	General purpose digital I/O pin.
		EBI_AD6	I/O	MFP2	EBI address/data bus bit 6.
		SPI1_SS	I/O	MFP4	SPI1 slave select pin.
		SD1_nCD	I	MFP5	SD/SDIO1 card detect input pin
		SC2_CLK	O	MFP6	Smart Card 2 clock pin.
		UART0_RXD	I	MFP7	UART0 data receiver input pin.
		I2C1_SDA	I/O	MFP8	I2C1 data input/output pin.
		EPWM1_CH5	I/O	MFP11	EPWM1 channel 5 output/capture input.
		BPWM1_CH3	I/O	MFP12	BPWM1 channel 3 output/capture input.
		ACMP1_WLAT	I	MFP13	Analog comparator 1 window latch input pin
		TM3	I/O	MFP14	Timer3 event counter input/toggle output pin.
INT0	I	MFP15	External interrupt 0 input pin.		

64 Pin	128 Pin	Pin Name	Type	MFP	Description
22	52	V _{SS}	P	MFP0	Ground pin for digital circuit.
23	53	V _{DD}	P	MFP0	Power supply for I/O ports and LDO source for internal PLL and digital circuit.
24	54	LDO_CAP	A	MFP0	LDO output pin.
25	55	PA.5	I/O	MFP0	General purpose digital I/O pin.
		SPIM_D2	I/O	MFP2	SPIM data 2 pin for Quad Mode I/O.
		QSPIO_MISO1	I/O	MFP3	Quad SPI0 MISO1 (Master In, Slave Out) pin.
		SPI1_I2SMCLK	I/O	MFP4	SPI1 I2S master clock output pin
		SD1_CMD	I/O	MFP5	SD/SDIO1 command/response pin
		SC2_nCD	I	MFP6	Smart Card 2 card detect pin.
		UART0_nCTS	I	MFP7	UART0 clear to Send input pin.
		UART5_TXD	O	MFP8	UART5 data transmitter output pin.
		I2C0_SCL	I/O	MFP9	I2C0 clock pin.
		CAN0_TXD	O	MFP10	CAN0 bus transmitter output.
		BPWM0_CH5	I/O	MFP12	BPWM0 channel 5 output/capture input.
		EPWM0_CH0	I/O	MFP13	EPWM0 channel 0 output/capture input.
QEI0_INDEX	I	MFP14	Quadrature encoder 0 index input		
26	56	PA.4	I/O	MFP0	General purpose digital I/O pin.
		SPIM_D3	I/O	MFP2	SPIM data 3 pin for Quad Mode I/O.
		QSPIO_MOSI1	I/O	MFP3	Quad SPI0 MOSI1 (Master Out, Slave In) pin.
		SPI0_I2SMCLK	I/O	MFP4	SPI0 I2S master clock output pin
		SD1_CLK	O	MFP5	SD/SDIO1 clock output pin
		SC0_nCD	I	MFP6	Smart Card 0 card detect pin.
		UART0_nRTS	O	MFP7	UART0 request to Send output pin.
		UART5_RXD	I	MFP8	UART5 data receiver input pin.
		I2C0_SDA	I/O	MFP9	I2C0 data input/output pin.
		CAN0_RXD	I	MFP10	CAN0 bus receiver input.
		BPWM0_CH4	I/O	MFP12	BPWM0 channel 4 output/capture input.
		EPWM0_CH1	I/O	MFP13	EPWM0 channel 1 output/capture input.
QEI0_A	I	MFP14	Quadrature encoder 0 phase A input		
27	57	PA.3	I/O	MFP0	General purpose digital I/O pin.
		SPIM_SS	I/O	MFP2	SPIM slave select pin.
		QSPIO_SS	I/O	MFP3	Quad SPI0 slave select pin.
		SPI0_SS	I/O	MFP4	SPI0 slave select pin.

64 Pin	128 Pin	Pin Name	Type	MFP	Description
		SD1_DAT3	I/O	MFP5	SD/SDIO1 data line bit 3.
		SC0_PWR	O	MFP6	Smart Card 0 power pin.
		UART4_TXD	O	MFP7	UART4 data transmitter output pin.
		UART1_TXD	O	MFP8	UART1 data transmitter output pin.
		I2C1_SCL	I/O	MFP9	I2C1 clock pin.
		BPWM0_CH3	I/O	MFP12	BPWM0 channel 3 output/capture input.
		EPWM0_CH2	I/O	MFP13	EPWM0 channel 2 output/capture input.
		QEI0_B	I	MFP14	Quadrature encoder 0 phase B input
28	58	PA.2	I/O	MFP0	General purpose digital I/O pin.
		SPIM_CLK	I/O	MFP2	SPIM serial clock pin.
		QSPIO_CLK	I/O	MFP3	Quad SPI0 serial clock pin.
		SPIO_CLK	I/O	MFP4	SPIO serial clock pin.
		SD1_DAT2	I/O	MFP5	SD/SDIO1 data line bit 2.
		SC0_RST	O	MFP6	Smart Card 0 reset pin.
		UART4_RXD	I	MFP7	UART4 data receiver input pin.
		UART1_RXD	I	MFP8	UART1 data receiver input pin.
		I2C1_SDA	I/O	MFP9	I2C1 data input/output pin.
		BPWM0_CH2	I/O	MFP12	BPWM0 channel 2 output/capture input.
		EPWM0_CH3	I/O	MFP13	EPWM0 channel 3 output/capture input.
29	59	PA.1	I/O	MFP0	General purpose digital I/O pin.
		SPIM_MISO	I/O	MFP2	SPIM MISO (Master In, Slave Out) pin.
		QSPIO_MISO0	I/O	MFP3	Quad SPI0 MISO0 (Master In, Slave Out) pin.
		SPIO_MISO	I/O	MFP4	SPIO MISO (Master In, Slave Out) pin.
		SD1_DAT1	I/O	MFP5	SD/SDIO1 data line bit 1.
		SC0_DAT	I/O	MFP6	Smart Card 0 data pin.
		UART0_TXD	O	MFP7	UART0 data transmitter output pin.
		UART1_nCTS	I	MFP8	UART1 clear to Send input pin.
		I2C2_SCL	I/O	MFP9	I2C2 clock pin.
		BPWM0_CH1	I/O	MFP12	BPWM0 channel 1 output/capture input.
		EPWM0_CH4	I/O	MFP13	EPWM0 channel 4 output/capture input.
		DAC1_ST	I	MFP15	DAC1 external trigger input.
30	60	PA.0	I/O	MFP0	General purpose digital I/O pin.
		SPIM_MOSI	I/O	MFP2	SPIM MOSI (Master Out, Slave In) pin.
		QSPIO_MOSI0	I/O	MFP3	Quad SPI0 MOSI0 (Master Out, Slave In) pin.

64 Pin	128 Pin	Pin Name	Type	MFP	Description
		SPI0_MOSI	I/O	MFP4	SPI0 MOSI (Master Out, Slave In) pin.
		SD1_DAT0	I/O	MFP5	SD/SDIO1 data line bit 0.
		SC0_CLK	O	MFP6	Smart Card 0 clock pin.
		UART0_RXD	I	MFP7	UART0 data receiver input pin.
		UART1_nRTS	O	MFP8	UART1 request to Send output pin.
		I2C2_SDA	I/O	MFP9	I2C2 data input/output pin.
		BPWM0_CH0	I/O	MFP12	BPWM0 channel 0 output/capture input.
		EPWM0_CH5	I/O	MFP13	EPWM0 channel 5 output/capture input.
		DAC0_ST	I	MFP15	DAC0 external trigger input.
31	61	V _{DDIO}	P	MFP0	Power supply for PA.0~PA.5.
	62	PE.14	I/O	MFP0	General purpose digital I/O pin.
		EBI_AD8	I/O	MFP2	EBI address/data bus bit 8.
		UART2_TXD	O	MFP3	UART2 data transmitter output pin.
		CAN0_TXD	O	MFP4	CAN0 bus transmitter output.
		SD1_nCD	I	MFP5	SD/SDIO1 card detect input pin
	63	PE.15	I/O	MFP0	General purpose digital I/O pin.
		EBI_AD9	I/O	MFP2	EBI address/data bus bit 9.
		UART2_RXD	I	MFP3	UART2 data receiver input pin.
		CAN0_RXD	I	MFP4	CAN0 bus receiver input.
32	64	nRESET	I	MFP0	External reset input: active LOW, with an internal pull-up. Set this pin low reset to initial state.
33	65	PF.0	I/O	MFP0	General purpose digital I/O pin.
		UART1_TXD	O	MFP2	UART1 data transmitter output pin.
		I2C1_SCL	I/O	MFP3	I2C1 clock pin.
		BPWM1_CH0	I/O	MFP12	BPWM1 channel 0 output/capture input.
		ICE_DAT	O	MFP14	Serial wired debugger data pin.
34	66	PF.1	I/O	MFP0	General purpose digital I/O pin.
		UART1_RXD	I	MFP2	UART1 data receiver input pin.
		I2C1_SDA	I/O	MFP3	I2C1 data input/output pin.
		BPWM1_CH1	I/O	MFP12	BPWM1 channel 1 output/capture input.
		ICE_CLK	I	MFP14	Serial wired debugger clock pin.
	67	PD.9	I/O	MFP0	General purpose digital I/O pin.
		EBI_AD7	I/O	MFP2	EBI address/data bus bit 7.
		I2C2_SCL	I/O	MFP3	I2C2 clock pin.

64 Pin	128 Pin	Pin Name	Type	MFP	Description
		UART2_nCTS	I	MFP4	UART2 clear to Send input pin.
	68	PD.8	I/O	MFP0	General purpose digital I/O pin.
		EBI_AD6	I/O	MFP2	EBI address/data bus bit 6.
		I2C2_SDA	I/O	MFP3	I2C2 data input/output pin.
		UART2_nRTS	O	MFP4	UART2 request to Send output pin.
35	69	PC.5	I/O	MFP0	General purpose digital I/O pin.
		EBI_AD5	I/O	MFP2	EBI address/data bus bit 5.
		SPIM_D2	I/O	MFP3	SPIM data 2 pin for Quad Mode I/O.
		QSPI0_MISO1	I/O	MFP4	Quad SPI0 MISO1 (Master In, Slave Out) pin.
		UART2_TXD	O	MFP8	UART2 data transmitter output pin.
		I2C1_SCL	I/O	MFP9	I2C1 clock pin.
		CAN0_TXD	O	MFP10	CAN0 bus transmitter output.
		UART4_TXD	O	MFP11	UART4 data transmitter output pin.
		EPWM1_CH0	I/O	MFP12	EPWM1 channel 0 output/capture input.
36	70	PC.4	I/O	MFP0	General purpose digital I/O pin.
		EBI_AD4	I/O	MFP2	EBI address/data bus bit 4.
		SPIM_D3	I/O	MFP3	SPIM data 3 pin for Quad Mode I/O.
		QSPI0_MOSI1	I/O	MFP4	Quad SPI0 MOSI1 (Master Out, Slave In) pin.
		SC1_nCD	I	MFP5	Smart Card 1 card detect pin.
		I2S0_BCLK	O	MFP6	I2S0 bit clock output pin.
		SPI1_I2SMCLK	I/O	MFP7	SPI1 I2S master clock output pin
		UART2_RXD	I	MFP8	UART2 data receiver input pin.
		I2C1_SDA	I/O	MFP9	I2C1 data input/output pin.
		CAN0_RXD	I	MFP10	CAN0 bus receiver input.
		UART4_RXD	I	MFP11	UART4 data receiver input pin.
		EPWM1_CH1	I/O	MFP12	EPWM1 channel 1 output/capture input.
		37	71	PC.3	I/O
EBI_AD3	I/O			MFP2	EBI address/data bus bit 3.
SPIM_SS	I/O			MFP3	SPIM slave select pin.
QSPI0_SS	I/O			MFP4	Quad SPI0 slave select pin.
SC1_PWR	O			MFP5	Smart Card 1 power pin.
I2S0_MCLK	O			MFP6	I2S0 master clock output pin.
SPI1_MISO	I/O			MFP7	SPI1 MISO (Master In, Slave Out) pin.
UART2_nRTS	O			MFP8	UART2 request to Send output pin.

64 Pin	128 Pin	Pin Name	Type	MFP	Description
		I2C0_SMBAL	O	MFP9	I2C0 SMBus SMBALTER pin
		CAN1_TXD	O	MFP10	CAN1 bus transmitter output.
		UART3_TXD	O	MFP11	UART3 data transmitter output pin.
		EPWM1_CH2	I/O	MFP12	EPWM1 channel 2 output/capture input.
38	72	PC.2	I/O	MFP0	General purpose digital I/O pin.
		EBI_AD2	I/O	MFP2	EBI address/data bus bit 2.
		SPIM_CLK	I/O	MFP3	SPIM serial clock pin.
		QSPI0_CLK	I/O	MFP4	Quad SPI0 serial clock pin.
		SC1_RST	O	MFP5	Smart Card 1 reset pin.
		I2S0_DI	I	MFP6	I2S0 data input pin.
		SPI1_MOSI	I/O	MFP7	SPI1 MOSI (Master Out, Slave In) pin.
		UART2_nCTS	I	MFP8	UART2 clear to Send input pin.
		I2C0_SMBUSUS	O	MFP9	I2C0 SMBus SMBSUS pin (PMBus CONTROL pin)
		CAN1_RXD	I	MFP10	CAN1 bus receiver input.
		UART3_RXD	I	MFP11	UART3 data receiver input pin.
		EPWM1_CH3	I/O	MFP12	EPWM1 channel 3 output/capture input.
39	73	PC.1	I/O	MFP0	General purpose digital I/O pin.
		EBI_AD1	I/O	MFP2	EBI address/data bus bit 1.
		SPIM_MISO	I/O	MFP3	SPIM MISO (Master In, Slave Out) pin.
		QSPI0_MISO0	I/O	MFP4	Quad SPI0 MISO0 (Master In, Slave Out) pin.
		SC1_DAT	I/O	MFP5	Smart Card 1 data pin.
		I2S0_DO	O	MFP6	I2S0 data output pin.
		SPI1_CLK	I/O	MFP7	SPI1 serial clock pin.
		UART2_TXD	O	MFP8	UART2 data transmitter output pin.
		I2C0_SCL	I/O	MFP9	I2C0 clock pin.
		EPWM1_CH4	I/O	MFP12	EPWM1 channel 4 output/capture input.
		ACMP0_O	O	MFP14	Analog comparator 0 output pin.
40	74	PC.0	I/O	MFP0	General purpose digital I/O pin.
		EBI_AD0	I/O	MFP2	EBI address/data bus bit 0.
		SPIM_MOSI	I/O	MFP3	SPIM MOSI (Master Out, Slave In) pin.
		QSPI0_MOSI0	I/O	MFP4	Quad SPI0 MOSI0 (Master Out, Slave In) pin.
		SC1_CLK	O	MFP5	Smart Card 1 clock pin.
		I2S0_LRCK	O	MFP6	I2S0 left right channel clock output pin.
		SPI1_SS	I/O	MFP7	SPI1 slave select pin.

64 Pin	128 Pin	Pin Name	Type	MFP	Description
		UART2_RXD	I	MFP8	UART2 data receiver input pin.
		I2C0_SDA	I/O	MFP9	I2C0 data input/output pin.
		EPWM1_CH5	I/O	MFP12	EPWM1 channel 5 output/capture input.
		ACMP1_O	O	MFP14	Analog comparator 1 output pin.
	75	V _{SS}	P	MFP0	Ground pin for digital circuit.
	76	V _{DD}	P	MFP0	Power supply for I/O ports and LDO source for internal PLL and digital circuit.
	77	PG.9	I/O	MFP0	General purpose digital I/O pin.
		EBI_AD0	I/O	MFP2	EBI address/data bus bit 0.
		SD1_DAT3	I/O	MFP3	SD/SDIO1 data line bit 3.
		SPIM_D2	I/O	MFP4	SPIM data 2 pin for Quad Mode I/O.
		BPWM0_CH5	I/O	MFP12	BPWM0 channel 5 output/capture input.
	78	PG.10	I/O	MFP0	General purpose digital I/O pin.
		EBI_AD1	I/O	MFP2	EBI address/data bus bit 1.
		SD1_DAT2	I/O	MFP3	SD/SDIO1 data line bit 2.
		SPIM_D3	I/O	MFP4	SPIM data 3 pin for Quad Mode I/O.
		BPWM0_CH4	I/O	MFP12	BPWM0 channel 4 output/capture input.
	79	PG.11	I/O	MFP0	General purpose digital I/O pin.
		EBI_AD2	I/O	MFP2	EBI address/data bus bit 2.
		SD1_DAT1	I/O	MFP3	SD/SDIO1 data line bit 1.
		SPIM_SS	I/O	MFP4	SPIM slave select pin.
		BPWM0_CH3	I/O	MFP12	BPWM0 channel 3 output/capture input.
	80	PG.12	I/O	MFP0	General purpose digital I/O pin.
		EBI_AD3	I/O	MFP2	EBI address/data bus bit 3.
		SD1_DAT0	I/O	MFP3	SD/SDIO1 data line bit 0.
		SPIM_CLK	I/O	MFP4	SPIM serial clock pin.
		BPWM0_CH2	I/O	MFP12	BPWM0 channel 2 output/capture input.
	81	PG.13	I/O	MFP0	General purpose digital I/O pin.
		EBI_AD4	I/O	MFP2	EBI address/data bus bit 4.
		SD1_CMD	I/O	MFP3	SD/SDIO1 command/response pin
		SPIM_MISO	I/O	MFP4	SPIM MISO (Master In, Slave Out) pin.
		BPWM0_CH1	I/O	MFP12	BPWM0 channel 1 output/capture input.
	82	PG.14	I/O	MFP0	General purpose digital I/O pin.
		EBI_AD5	I/O	MFP2	EBI address/data bus bit 5.

64 Pin	128 Pin	Pin Name	Type	MFP	Description
		SD1_CLK	O	MFP3	SD/SDIO1 clock output pin
		SPIM_MOSI	I/O	MFP4	SPIM MOSI (Master Out, Slave In) pin.
		BPWM0_CH0	I/O	MFP12	BPWM0 channel 0 output/capture input.
	83	PG.15	I/O	MFP0	General purpose digital I/O pin.
		SD1_nCD	I	MFP3	SD/SDIO1 card detect input pin
		CLKO	O	MFP14	Clock Out
		EADC0_ST	I	MFP15	EADC0 external trigger input.
	84	PD.13	I/O	MFP0	General purpose digital I/O pin.
		EBI_AD10	I/O	MFP2	EBI address/data bus bit 10.
		SD0_nCD	I	MFP3	SD/SDIO0 card detect input pin
		SPI0_I2SMCLK	I/O	MFP4	SPI0 I2S master clock output pin
		SPI1_I2SMCLK	I/O	MFP5	SPI1 I2S master clock output pin
		SC2_nCD	I	MFP7	Smart Card 2 card detect pin.
	85	PA.12	I/O	MFP0	General purpose digital I/O pin.
		I2S0_BCLK	O	MFP2	I2S0 bit clock output pin.
		UART4_TXD	O	MFP3	UART4 data transmitter output pin.
		I2C1_SCL	I/O	MFP4	I2C1 clock pin.
		SPI2_SS	I/O	MFP5	SPI2 slave select pin.
		CAN0_TXD	O	MFP6	CAN0 bus transmitter output.
		SC2_PWR	O	MFP7	Smart Card 2 power pin.
		BPWM1_CH2	I/O	MFP11	BPWM1 channel 2 output/capture input.
		QE11_INDEX	I	MFP12	Quadrature encoder 1 index input
		USB_VBUS	P	MFP14	Power supply from USB host or HUB.
	86	PA.13	I/O	MFP0	General purpose digital I/O pin.
		I2S0_MCLK	O	MFP2	I2S0 master clock output pin.
		UART4_RXD	I	MFP3	UART4 data receiver input pin.
		I2C1_SDA	I/O	MFP4	I2C1 data input/output pin.
		SPI2_CLK	I/O	MFP5	SPI2 serial clock pin.
		CAN0_RXD	I	MFP6	CAN0 bus receiver input.
		SC2_RST	O	MFP7	Smart Card 2 reset pin.
		BPWM1_CH3	I/O	MFP11	BPWM1 channel 3 output/capture input.
		QE11_A	I	MFP12	Quadrature encoder 1 phase A input
		USB_D-	A	MFP14	USB differential signal D-.
	87	PA.14	I/O	MFP0	General purpose digital I/O pin.

64 Pin	128 Pin	Pin Name	Type	MFP	Description
		I2S0_DI	I	MFP2	I2S0 data input pin.
		UART0_TXD	O	MFP3	UART0 data transmitter output pin.
		SPI2_MISO	I/O	MFP5	SPI2 MISO (Master In, Slave Out) pin.
		I2C2_SCL	I/O	MFP6	I2C2 clock pin.
		SC2_DAT	I/O	MFP7	Smart Card 2 data pin.
		BPWM1_CH4	I/O	MFP11	BPWM1 channel 4 output/capture input.
		QE11_B	I	MFP12	Quadrature encoder 1 phase B input
		USB_D+	A	MFP14	USB differential signal D+.
	88	PA.15	I/O	MFP0	General purpose digital I/O pin.
		I2S0_DO	O	MFP2	I2S0 data output pin.
		UART0_RXD	I	MFP3	UART0 data receiver input pin.
		SPI2_MOSI	I/O	MFP5	SPI2 MOSI (Master Out, Slave In) pin.
		I2C2_SDA	I/O	MFP6	I2C2 data input/output pin.
		SC2_CLK	O	MFP7	Smart Card 2 clock pin.
		BPWM1_CH5	I/O	MFP11	BPWM1 channel 5 output/capture input.
		EPWM0_SYNC_IN	I	MFP12	EPWM0 counter synchronous trigger input pin.
		USB_OTG_ID	I	MFP14	USB_ identification.
41	89	HSUSB_VRES	A	MFP0	HSUSB module reference resistor
42	90	HSUSB_VDD33	P	MFP0	Power supply for HSUSB VDD33
43	91	HSUSB_VBUS	P	MFP0	HSUSB Power supply from USB host or HUB.
44	92	HSUSB_D-	A	MFP0	HSUSB differential signal D-.
45	93	HSUSB_VSS	P	MFP0	Ground pin for HSUSB.
46	94	HSUSB_D+	A	MFP0	HSUSB differential signal D+.
47	95	HSUSB_VDD12_CAP	A	MFP0	HSUSB Internal power regulator output 1.2V decoupling pin. Note: This pin needs to be connected with a 1uF capacitor.
48	96	HSUSB_ID	I	MFP0	HSUSB identification.
	97	PE.7	I/O	MFP0	General purpose digital I/O pin.
		SD0_CMD	I/O	MFP3	SD/SDIO0 command/response pin
		SPIM_D2	I/O	MFP4	SPIM data 2 pin for Quad Mode I/O.
		UART5_TXD	O	MFP8	UART5 data transmitter output pin.
		CAN1_TXD	O	MFP9	CAN1 bus transmitter output.
		QE11_INDEX	I	MFP11	Quadrature encoder 1 index input
		EPWM0_CH0	I/O	MFP12	EPWM0 channel 0 output/capture input.
		BPWM0_CH5	I/O	MFP13	BPWM0 channel 5 output/capture input.

64 Pin	128 Pin	Pin Name	Type	MFP	Description
	98	PE.6	I/O	MFP0	General purpose digital I/O pin.
		SD0_CLK	O	MFP3	SD/SDIO0 clock output pin
		SPIM_D3	I/O	MFP4	SPIM data 3 pin for Quad Mode I/O.
		SPI3_I2SMCLK	I/O	MFP5	SPI3 I2S master clock output pin
		SC0_nCD	I	MFP6	Smart Card 0 card detect pin.
		USCI0_CTL0	I/O	MFP7	USCI0 control 0 pin.
		UART5_RXD	I	MFP8	UART5 data receiver input pin.
		CAN1_RXD	I	MFP9	CAN1 bus receiver input.
		QE11_A	I	MFP11	Quadrature encoder 1 phase A input
		EPWM0_CH1	I/O	MFP12	EPWM0 channel 1 output/capture input.
		BPWM0_CH4	I/O	MFP13	BPWM0 channel 4 output/capture input.
	99	PE.5	I/O	MFP0	General purpose digital I/O pin.
		EBI_nRD	O	MFP2	EBI read enable output pin.
		SD0_DAT3	I/O	MFP3	SD/SDIO0 data line bit 3.
		SPIM_SS	I/O	MFP4	SPIM slave select pin.
		SPI3_SS	I/O	MFP5	SPI3 slave select pin.
		SC0_PWR	O	MFP6	Smart Card 0 power pin.
		USCI0_CTL1	I/O	MFP7	USCI0 control 1 pin.
		QE11_B	I	MFP11	Quadrature encoder 1 phase B input
		EPWM0_CH2	I/O	MFP12	EPWM0 channel 2 output/capture input.
		BPWM0_CH3	I/O	MFP13	BPWM0 channel 3 output/capture input.
	100	PE.4	I/O	MFP0	General purpose digital I/O pin.
		EBI_nWR	O	MFP2	EBI write enable output pin.
		SD0_DAT2	I/O	MFP3	SD/SDIO0 data line bit 2.
		SPIM_CLK	I/O	MFP4	SPIM serial clock pin.
		SPI3_CLK	I/O	MFP5	SPI3 serial clock pin.
		SC0_RST	O	MFP6	Smart Card 0 reset pin.
		USCI0_DAT1	I/O	MFP7	USCI0 data 1 pin.
		QE10_INDEX	I	MFP11	Quadrature encoder 0 index input
		EPWM0_CH3	I/O	MFP12	EPWM0 channel 3 output/capture input.
		BPWM0_CH2	I/O	MFP13	BPWM0 channel 2 output/capture input.
	101	PE.3	I/O	MFP0	General purpose digital I/O pin.
		EBI_MCLK	O	MFP2	EBI external clock output pin.
		SD0_DAT1	I/O	MFP3	SD/SDIO0 data line bit 1.

64 Pin	128 Pin	Pin Name	Type	MFP	Description
		SPIM_MISO	I/O	MFP4	SPIM MISO (Master In, Slave Out) pin.
		SPI3_MISO	I/O	MFP5	SPI3 MISO (Master In, Slave Out) pin.
		SC0_DAT	I/O	MFP6	Smart Card 0 data pin.
		USCI0_DAT0	I/O	MFP7	USCI0 data 0 pin.
		QEI0_A	I	MFP11	Quadrature encoder 0 phase A input
		EPWM0_CH4	I/O	MFP12	EPWM0 channel 4 output/capture input.
		BPWM0_CH1	I/O	MFP13	BPWM0 channel 1 output/capture input.
	102	PE.2	I/O	MFP0	General purpose digital I/O pin.
		EBI_ALE	O	MFP2	EBI address latch enable output pin.
		SD0_DAT0	I/O	MFP3	SD/SDIO0 data line bit 0.
		SPIM_MOSI	I/O	MFP4	SPIM MOSI (Master Out, Slave In) pin.
		SPI3_MOSI	I/O	MFP5	SPI3 MOSI (Master Out, Slave In) pin.
		SC0_CLK	O	MFP6	Smart Card 0 clock pin.
		USCI0_CLK	I/O	MFP7	USCI0 clock pin.
		QEI0_B	I	MFP11	Quadrature encoder 0 phase B input
		EPWM0_CH5	I/O	MFP12	EPWM0 channel 5 output/capture input.
		BPWM0_CH0	I/O	MFP13	BPWM0 channel 0 output/capture input.
	103	V _{SS}	P	MFP0	Ground pin for digital circuit.
	104	V _{DD}	P	MFP0	Power supply for I/O ports and LDO source for internal PLL and digital circuit.
	105	PE.1	I/O	MFP0	General purpose digital I/O pin.
		EBI_AD10	I/O	MFP2	EBI address/data bus bit 10.
		QSPI0_MISO0	I/O	MFP3	Quad SPI0 MISO0 (Master In, Slave Out) pin.
		SC2_DAT	I/O	MFP4	Smart Card 2 data pin.
		I2S0_BCLK	O	MFP5	I2S0 bit clock output pin.
		SPI1_MISO	I/O	MFP6	SPI1 MISO (Master In, Slave Out) pin.
		UART3_TXD	O	MFP7	UART3 data transmitter output pin.
		I2C1_SCL	I/O	MFP8	I2C1 clock pin.
		UART4_nCTS	I	MFP9	UART4 clear to Send input pin.
	106	PE.0	I/O	MFP0	General purpose digital I/O pin.
		EBI_AD11	I/O	MFP2	EBI address/data bus bit 11.
		QSPI0_MOSI0	I/O	MFP3	Quad SPI0 MOSI0 (Master Out, Slave In) pin.
		SC2_CLK	O	MFP4	Smart Card 2 clock pin.
		I2S0_MCLK	O	MFP5	I2S0 master clock output pin.

64 Pin	128 Pin	Pin Name	Type	MFP	Description
		SPI1_MOSI	I/O	MFP6	SPI1 MOSI (Master Out, Slave In) pin.
		UART3_RXD	I	MFP7	UART3 data receiver input pin.
		I2C1_SDA	I/O	MFP8	I2C1 data input/output pin.
		UART4_nRTS	O	MFP9	UART4 request to Send output pin.
	107	PH.8	I/O	MFP0	General purpose digital I/O pin.
		EBI_AD12	I/O	MFP2	EBI address/data bus bit 12.
		QSPI0_CLK	I/O	MFP3	Quad SPI0 serial clock pin.
		SC2_PWR	O	MFP4	Smart Card 2 power pin.
		I2S0_DI	I	MFP5	I2S0 data input pin.
		SPI1_CLK	I/O	MFP6	SPI1 serial clock pin.
		UART3_nRTS	O	MFP7	UART3 request to Send output pin.
		I2C1_SMBAL	O	MFP8	I2C1 SMBus SMBALTER pin
		I2C2_SCL	I/O	MFP9	I2C2 clock pin.
		UART1_TXD	O	MFP10	UART1 data transmitter output pin.
	108	PH.9	I/O	MFP0	General purpose digital I/O pin.
		EBI_AD13	I/O	MFP2	EBI address/data bus bit 13.
		QSPI0_SS	I/O	MFP3	Quad SPI0 slave select pin.
		SC2_RST	O	MFP4	Smart Card 2 reset pin.
		I2S0_DO	O	MFP5	I2S0 data output pin.
		SPI1_SS	I/O	MFP6	SPI1 slave select pin.
		UART3_nCTS	I	MFP7	UART3 clear to Send input pin.
		I2C1_SMBUSUS	O	MFP8	I2C1 SMBus SMBUSUS pin (PMBus CONTROL pin)
		I2C2_SDA	I/O	MFP9	I2C2 data input/output pin.
		UART1_RXD	I	MFP10	UART1 data receiver input pin.
	109	PH.10	I/O	MFP0	General purpose digital I/O pin.
		EBI_AD14	I/O	MFP2	EBI address/data bus bit 14.
		QSPI0_MISO1	I/O	MFP3	Quad SPI0 MISO1 (Master In, Slave Out) pin.
		SC2_nCD	I	MFP4	Smart Card 2 card detect pin.
		I2S0_LRCK	O	MFP5	I2S0 left right channel clock output pin.
		SPI1_I2SMCLK	I/O	MFP6	SPI1 I2S master clock output pin
		UART4_TXD	O	MFP7	UART4 data transmitter output pin.
		UART0_TXD	O	MFP8	UART0 data transmitter output pin.
	110	PH.11	I/O	MFP0	General purpose digital I/O pin.
		EBI_AD15	I/O	MFP2	EBI address/data bus bit 15.

64 Pin	128 Pin	Pin Name	Type	MFP	Description
		QSPI0_MOSI1	I/O	MFP3	Quad SPI0 MOSI1 (Master Out, Slave In) pin.
		UART4_RXD	I	MFP7	UART4 data receiver input pin.
		UART0_RXD	I	MFP8	UART0 data receiver input pin.
		EPWM0_CH5	I/O	MFP11	EPWM0 channel 5 output/capture input.
	111	PD.14	I/O	MFP0	General purpose digital I/O pin.
		EBI_nCS0	O	MFP2	EBI chip select 0 output pin.
		SPI3_I2SMCLK	I/O	MFP3	SPI3 I2S master clock output pin
		SC1_nCD	I	MFP4	Smart Card 1 card detect pin.
		EPWM0_CH4	I/O	MFP11	EPWM0 channel 4 output/capture input.
49	112	V _{SS}	P	MFP0	Ground pin for digital circuit.
50	113	LDO_CAP	A	MFP0	LDO output pin.
51	114	V _{DD}	P	MFP0	Power supply for I/O ports and LDO source for internal PLL and digital circuit.
	115	PC.14	I/O	MFP0	General purpose digital I/O pin.
		EBI_AD11	I/O	MFP2	EBI address/data bus bit 11.
		SC1_nCD	I	MFP3	Smart Card 1 card detect pin.
		SPI0_I2SMCLK	I/O	MFP4	SPI0 I2S master clock output pin
		USCI0_CTL0	I/O	MFP5	USCI0 control 0 pin.
		QSPI0_CLK	I/O	MFP6	Quad SPI0 serial clock pin.
		EPWM0_SYNC_IN	I	MFP11	EPWM0 counter synchronous trigger input pin.
		TM1	I/O	MFP13	Timer1 event counter input/toggle output pin.
		USB_VBUS_ST	I	MFP14	USB external VBUS regulator status pin.
		HSUSB_VBUS_ST	I	MFP15	HSUSB external VBUS regulator status pin.
	116	PB.15	I/O	MFP0	General purpose digital I/O pin.
		EADC0_CH15	A	MFP1	EADC0 channel 15 analog input.
		EBI_AD12	I/O	MFP2	EBI address/data bus bit 12.
		SC1_PWR	O	MFP3	Smart Card 1 power pin.
		SPI0_SS	I/O	MFP4	SPI0 slave select pin.
		USCI0_CTL1	I/O	MFP5	USCI0 control 1 pin.
		UART0_nCTS	I	MFP6	UART0 clear to Send input pin.
		UART3_TXD	O	MFP7	UART3 data transmitter output pin.
		I2C2_SMBAL	O	MFP8	I2C2 SMBus SMBALTER pin
		EPWM1_CH0	I/O	MFP11	EPWM1 channel 0 output/capture input.
		TM0_EXT	I/O	MFP13	Timer0 external capture input/toggle output pin.

64 Pin	128 Pin	Pin Name	Type	MFP	Description
		USB_VBUS_EN	O	MFP14	USB external VBUS regulator enable pin.
		HSUSB_VBUS_EN	O	MFP15	HSUSB external VBUS regulator enable pin.
54	117	PB.14	I/O	MFP0	General purpose digital I/O pin.
		EADC0_CH14	A	MFP1	EADC0 channel 14 analog input.
		EBI_AD13	I/O	MFP2	EBI address/data bus bit 13.
		SC1_RST	O	MFP3	Smart Card 1 reset pin.
		SPI0_CLK	I/O	MFP4	SPI0 serial clock pin.
		USCI0_DAT1	I/O	MFP5	USCI0 data 1 pin.
		UART0_nRTS	O	MFP6	UART0 request to Send output pin.
		UART3_RXD	I	MFP7	UART3 data receiver input pin.
		I2C2_SMBUS	O	MFP8	I2C2 SMBus SMBSUS pin (PMBus CONTROL pin)
		EPWM1_CH1	I/O	MFP11	EPWM1 channel 1 output/capture input.
		TM1_EXT	I/O	MFP13	Timer1 external capture input/toggle output pin.
		CLKO	O	MFP14	Clock Out
55	118	PB.13	I/O	MFP0	General purpose digital I/O pin.
		EADC0_CH13	A	MFP1	EADC0 channel 13 analog input.
		DAC1_OUT	A	MFP1	DAC1 channel analog output.
		ACMP0_P3	A	MFP1	Analog comparator 0 positive input 3 pin.
		ACMP1_P3	A	MFP1	Analog comparator 1 positive input 3 pin.
		EBI_AD14	I/O	MFP2	EBI address/data bus bit 14.
		SC1_DAT	I/O	MFP3	Smart Card 1 data pin.
		SPI0_MISO	I/O	MFP4	SPI0 MISO (Master In, Slave Out) pin.
		USCI0_DAT0	I/O	MFP5	USCI0 data 0 pin.
		UART0_TXD	O	MFP6	UART0 data transmitter output pin.
		UART3_nRTS	O	MFP7	UART3 request to Send output pin.
		I2C2_SCL	I/O	MFP8	I2C2 clock pin.
		EPWM1_CH2	I/O	MFP11	EPWM1 channel 2 output/capture input.
		TM2_EXT	I/O	MFP13	Timer2 external capture input/toggle output pin.
56	119	PB.12	I/O	MFP0	General purpose digital I/O pin.
		EADC0_CH12	A	MFP1	EADC0 channel 12 analog input.
		DAC0_OUT	A	MFP1	DAC0 channel analog output.
		ACMP0_P2	A	MFP1	Analog comparator 0 positive input 2 pin.
		ACMP1_P2	A	MFP1	Analog comparator 1 positive input 2 pin.
		EBI_AD15	I/O	MFP2	EBI address/data bus bit 15.

64 Pin	128 Pin	Pin Name	Type	MFP	Description
		SC1_CLK	O	MFP3	Smart Card 1 clock pin.
		SPI0_MOSI	I/O	MFP4	SPI0 MOSI (Master Out, Slave In) pin.
		USCI0_CLK	I/O	MFP5	USCI0 clock pin.
		UART0_RXD	I	MFP6	UART0 data receiver input pin.
		UART3_nCTS	I	MFP7	UART3 clear to Send input pin.
		I2C2_SDA	I/O	MFP8	I2C2 data input/output pin.
		SD0_nCD	I	MFP9	SD/SDIO0 card detect input pin
		EPWM1_CH3	I/O	MFP11	EPWM1 channel 3 output/capture input.
		TM3_EXT	I/O	MFP13	Timer3 external capture input/toggle output pin.
57	120	AV _{DD}	P	MFP0	Power supply for internal analog circuit.
58	121	V _{REF}	A	MFP0	ADC reference voltage input. Note: This pin needs to be connected with a 1uF capacitor.
59	122	AV _{SS}	P	MFP0	Ground pin for analog circuit.
60	123	PB.11	I/O	MFP0	General purpose digital I/O pin.
		EADC0_CH11	A	MFP1	EADC0 channel 11 analog input.
		EBI_ADR16	O	MFP2	EBI address bus bit 16.
		UART0_nCTS	I	MFP5	UART0 clear to Send input pin.
		UART4_TXD	O	MFP6	UART4 data transmitter output pin.
		I2C1_SCL	I/O	MFP7	I2C1 clock pin.
		CAN0_TXD	O	MFP8	CAN0 bus transmitter output.
		SPI0_I2SMCLK	I/O	MFP9	SPI0 I2S master clock output pin
		BPWM1_CH0	I/O	MFP10	BPWM1 channel 0 output/capture input.
		SPI3_CLK	I/O	MFP11	SPI3 serial clock pin.
		HSUSB_VBUS_ST	I	MFP14	HSUSB external VBUS regulator status pin.
61	124	PB.10	I/O	MFP0	General purpose digital I/O pin.
		EADC0_CH10	A	MFP1	EADC0 channel 10 analog input.
		EBI_ADR17	O	MFP2	EBI address bus bit 17.
		USCI1_CTL0	I/O	MFP4	USCI1 control 0 pin.
		UART0_nRTS	O	MFP5	UART0 request to Send output pin.
		UART4_RXD	I	MFP6	UART4 data receiver input pin.
		I2C1_SDA	I/O	MFP7	I2C1 data input/output pin.
		CAN0_RXD	I	MFP8	CAN0 bus receiver input.
		BPWM1_CH1	I/O	MFP10	BPWM1 channel 1 output/capture input.
		SPI3_SS	I/O	MFP11	SPI3 slave select pin.

64 Pin	128 Pin	Pin Name	Type	MFP	Description		
		HSUSB_VBUS_EN	O	MFP14	HSUSB external VBUS regulator enable pin.		
62	125	PB.9	I/O	MFP0	General purpose digital I/O pin.		
		EADC0_CH9	A	MFP1	EADC0 channel 9 analog input.		
		EBI_ADR18	O	MFP2	EBI address bus bit 18.		
		USCI1_CTL1	I/O	MFP4	USCI1 control 1 pin.		
		UART0_TXD	O	MFP5	UART0 data transmitter output pin.		
		UART1_nCTS	I	MFP6	UART1 clear to Send input pin.		
		I2C1_SMBAL	O	MFP7	I2C1 SMBus SMBALTER pin		
		BPWM1_CH2	I/O	MFP10	BPWM1 channel 2 output/capture input.		
		SPI3_MISO	I/O	MFP11	SPI3 MISO (Master In, Slave Out) pin.		
				INT7	I	MFP13	External interrupt 7 input pin.
63	126	PB.8	I/O	MFP0	General purpose digital I/O pin.		
		EADC0_CH8	A	MFP1	EADC0 channel 8 analog input.		
		EBI_ADR19	O	MFP2	EBI address bus bit 19.		
		USCI1_CLK	I/O	MFP4	USCI1 clock pin.		
		UART0_RXD	I	MFP5	UART0 data receiver input pin.		
		UART1_nRTS	O	MFP6	UART1 request to Send output pin.		
		I2C1_SMBUSUS	O	MFP7	I2C1 SMBus SMBSUS pin (PMBus CONTROL pin)		
		BPWM1_CH3	I/O	MFP10	BPWM1 channel 3 output/capture input.		
		SPI3_MOSI	I/O	MFP11	SPI3 MOSI (Master Out, Slave In) pin.		
				INT6	I	MFP13	External interrupt 6 input pin.
64	127	PB.7	I/O	MFP0	General purpose digital I/O pin.		
		EADC0_CH7	A	MFP1	EADC0 channel 7 analog input.		
		EBI_nWRL	O	MFP2	EBI low byte write enable output pin.		
		USCI1_DAT0	I/O	MFP4	USCI1 data 0 pin.		
		CAN1_TXD	O	MFP5	CAN1 bus transmitter output.		
		UART1_TXD	O	MFP6	UART1 data transmitter output pin.		
		SD1_CMD	I/O	MFP7	SD/SDIO1 command/response pin		
		EBI_nCS0	O	MFP8	EBI chip select 0 output pin.		
		BPWM1_CH4	I/O	MFP10	BPWM1 channel 4 output/capture input.		
		EPWM1_BRAKE0	I	MFP11	EPWM1 Brake 0 input pin.		
		EPWM1_CH4	I/O	MFP12	EPWM1 channel 4 output/capture input.		
				INT5	I	MFP13	External interrupt 5 input pin.
				USB_VBUS_ST	I	MFP14	USB external VBUS regulator status pin.

64 Pin	128 Pin	Pin Name	Type	MFP	Description
		ACMP0_O	O	MFP15	Analog comparator 0 output pin.
1	128	PB.6	I/O	MFP0	General purpose digital I/O pin.
		EADC0_CH6	A	MFP1	EADC0 channel 6 analog input.
		EBI_nWRH	O	MFP2	EBI high byte write enable output pin
		USCI1_DAT1	I/O	MFP4	USCI1 data 1 pin.
		CAN1_RXD	I	MFP5	CAN1 bus receiver input.
		UART1_RXD	I	MFP6	UART1 data receiver input pin.
		SD1_CLK	O	MFP7	SD/SDIO1 clock output pin
		EBI_nCS1	O	MFP8	EBI chip select 1 output pin.
		BPWM1_CH5	I/O	MFP10	BPWM1 channel 5 output/capture input.
		EPWM1_BRAKE1	I	MFP11	EPWM1 Brake 1 input pin.
		EPWM1_CH5	I/O	MFP12	EPWM1 channel 5 output/capture input.
		INT4	I	MFP13	External interrupt 4 input pin.
		USB_VBUS_EN	O	MFP14	USB external VBUS regulator enable pin.
		ACMP1_O	O	MFP15	Analog comparator 1 output pin.

4.2.4 M484 Series Pin Description

64 Pin: M484SGAAE, M484SIDAE

64 Pin 2 USB: M484SGAAE2U, M484SIDAE2U

64 Pin	64 Pin 2 USB	128 Pin	Pin Name	Type	MFP	Description
2	2	1	PB.5	I/O	MFP0	General purpose digital I/O pin.
			EADC0_CH5	A	MFP1	EADC0 channel 5 analog input.
			ACMP1_N	A	MFP1	Analog comparator 1 negative input pin.
			EBI_ADR0	O	MFP2	EBI address bus bit 0.
			SD0_DAT3	I/O	MFP3	SD/SDIO0 data line bit 3.
			SPI1_MISO	I/O	MFP5	SPI1 MISO (Master In, Slave Out) pin.
			I2C0_SCL	I/O	MFP6	I2C0 clock pin.
			UART5_TXD	O	MFP7	UART5 data transmitter output pin.
			USCI1_CTL0	I/O	MFP8	USCI1 control 0 pin.
			SC0_CLK	O	MFP9	Smart Card 0 clock pin.
			I2S0_BCLK	O	MFP10	I2S0 bit clock output pin.
			EPWM0_CH0	I/O	MFP11	EPWM0 channel 0 output/capture input.
			TM0	I/O	MFP14	Timer0 event counter input/toggle output pin.
INT0	I	MFP15	External interrupt 0 input pin.			
3	3	2	PB.4	I/O	MFP0	General purpose digital I/O pin.
			EADC0_CH4	A	MFP1	EADC0 channel 4 analog input.
			ACMP1_P1	A	MFP1	Analog comparator 1 positive input 1 pin.
			EBI_ADR1	O	MFP2	EBI address bus bit 1.
			SD0_DAT2	I/O	MFP3	SD/SDIO0 data line bit 2.
			SPI1_MOSI	I/O	MFP5	SPI1 MOSI (Master Out, Slave In) pin.
			I2C0_SDA	I/O	MFP6	I2C0 data input/output pin.
			UART5_RXD	I	MFP7	UART5 data receiver input pin.
			USCI1_CTL1	I/O	MFP8	USCI1 control 1 pin.
			SC0_DAT	I/O	MFP9	Smart Card 0 data pin.
			I2S0_MCLK	O	MFP10	I2S0 master clock output pin.
			EPWM0_CH1	I/O	MFP11	EPWM0 channel 1 output/capture input.
			TM1	I/O	MFP14	Timer1 event counter input/toggle output pin.
INT1	I	MFP15	External interrupt 1 input pin.			
4	4	3	PB.3	I/O	MFP0	General purpose digital I/O pin.
			EADC0_CH3	A	MFP1	EADC0 channel 3 analog input.
			ACMP0_N	A	MFP1	Analog comparator 0 negative input pin.

64 Pin	64 Pin 2 USB	128 Pin	Pin Name	Type	MFP	Description
			EBI_ADR2	O	MFP2	EBI address bus bit 2.
			SD0_DAT1	I/O	MFP3	SD/SDIO0 data line bit 1.
			SPI1_CLK	I/O	MFP5	SPI1 serial clock pin.
			UART1_TXD	O	MFP6	UART1 data transmitter output pin.
			UART5_nRTS	O	MFP7	UART5 request to Send output pin.
			USCI1_DAT1	I/O	MFP8	USCI1 data 1 pin.
			SC0_RST	O	MFP9	Smart Card 0 reset pin.
			I2S0_DI	I	MFP10	I2S0 data input pin.
			EPWM0_CH2	I/O	MFP11	EPWM0 channel 2 output/capture input.
			TM2	I/O	MFP14	Timer2 event counter input/toggle output pin.
			INT2	I	MFP15	External interrupt 2 input pin.
5	5	4	PB.2	I/O	MFP0	General purpose digital I/O pin.
			EADC0_CH2	A	MFP1	EADC0 channel 2 analog input.
			ACMP0_P1	A	MFP1	Analog comparator 0 positive input 1 pin.
			OPA0_O	A	MFP1	Operational amplifier 0 output pin.
			EBI_ADR3	O	MFP2	EBI address bus bit 3.
			SD0_DAT0	I/O	MFP3	SD/SDIO0 data line bit 0.
			SPI1_SS	I/O	MFP5	SPI1 slave select pin.
			UART1_RXD	I	MFP6	UART1 data receiver input pin.
			UART5_nCTS	I	MFP7	UART5 clear to Send input pin.
			USCI1_DAT0	I/O	MFP8	USCI1 data 0 pin.
			SC0_PWR	O	MFP9	Smart Card 0 power pin.
			I2S0_DO	O	MFP10	I2S0 data output pin.
			EPWM0_CH3	I/O	MFP11	EPWM0 channel 3 output/capture input.
			TM3	I/O	MFP14	Timer3 event counter input/toggle output pin.
			INT3	I	MFP15	External interrupt 3 input pin.
		5	PC.12	I/O	MFP0	General purpose digital I/O pin.
			EBI_ADR4	O	MFP2	EBI address bus bit 4.
			UART0_TXD	O	MFP3	UART0 data transmitter output pin.
			I2C0_SCL	I/O	MFP4	I2C0 clock pin.
			SPI3_MISO	I/O	MFP6	SPI3 MISO (Master In, Slave Out) pin.
			SC0_nCD	I	MFP9	Smart Card 0 card detect pin.
			ECAP1_IC2	I	MFP11	Enhanced capture unit 1 input 2 pin.
			EPWM1_CH0	I/O	MFP12	EPWM1 channel 0 output/capture input.

64 Pin	64 Pin 2 USB	128 Pin	Pin Name	Type	MFP	Description
			ACMP0_O	O	MFP14	Analog comparator 0 output pin.
		6	PC.11	I/O	MFP0	General purpose digital I/O pin.
			EBI_ADR5	O	MFP2	EBI address bus bit 5.
			UART0_RXD	I	MFP3	UART0 data receiver input pin.
			I2C0_SDA	I/O	MFP4	I2C0 data input/output pin.
			SPI3_MOSI	I/O	MFP6	SPI3 MOSI (Master Out, Slave In) pin.
			ECAP1_IC1	I	MFP11	Enhanced capture unit 1 input 1 pin.
			EPWM1_CH1	I/O	MFP12	EPWM1 channel 1 output/capture input.
			ACMP1_O	O	MFP14	Analog comparator 1 output pin.
		7	PC.10	I/O	MFP0	General purpose digital I/O pin.
			EBI_ADR6	O	MFP2	EBI address bus bit 6.
			SPI3_CLK	I/O	MFP6	SPI3 serial clock pin.
			UART3_TXD	O	MFP7	UART3 data transmitter output pin.
			ECAP1_IC0	I	MFP11	Enhanced capture unit 1 input 0 pin.
			EPWM1_CH2	I/O	MFP12	EPWM1 channel 2 output/capture input.
		8	PC.9	I/O	MFP0	General purpose digital I/O pin.
			EBI_ADR7	O	MFP2	EBI address bus bit 7.
			SPI3_SS	I/O	MFP6	SPI3 slave select pin.
			UART3_RXD	I	MFP7	UART3 data receiver input pin.
			EPWM1_CH3	I/O	MFP12	EPWM1 channel 3 output/capture input.
6	6	9	PB.1	I/O	MFP0	General purpose digital I/O pin.
			EADC0_CH1	A	MFP1	EADC0 channel 1 analog input.
			OPA0_N	A	MFP1	Operational amplifier 0 negative input pin.
			EBI_ADR8	O	MFP2	EBI address bus bit 8.
			SD0_CLK	O	MFP3	SD/SDIO0 clock output pin
			SPI1_I2SMCLK	I/O	MFP5	SPI1 I2S master clock output pin
			SPI3_I2SMCLK	I/O	MFP6	SPI3 I2S master clock output pin
			UART2_TXD	O	MFP7	UART2 data transmitter output pin.
			USCI1_CLK	I/O	MFP8	USCI1 clock pin.
			I2C1_SCL	I/O	MFP9	I2C1 clock pin.
			I2S0_LRCK	O	MFP10	I2S0 left right channel clock output pin.
			EPWM0_CH4	I/O	MFP11	EPWM0 channel 4 output/capture input.
			EPWM1_CH4	I/O	MFP12	EPWM1 channel 4 output/capture input.
			EPWM0_BRAKE0	I	MFP13	EPWM0 Brake 0 input pin.

64 Pin	64 Pin 2 USB	128 Pin	Pin Name	Type	MFP	Description
7	7	10	PB.0	I/O	MFP0	General purpose digital I/O pin.
			EADC0_CH0	A	MFP1	EADC0 channel 0 analog input.
			OPA0_P	A	MFP1	Operational amplifier 0 positive input pin.
			EBI_ADR9	O	MFP2	EBI address bus bit 9.
			SD0_CMD	I/O	MFP3	SD/SDIO0 command/response pin
			UART2_RXD	I	MFP7	UART2 data receiver input pin.
			SPI0_I2SMCLK	I/O	MFP8	SPI0 I2S master clock output pin
			I2C1_SDA	I/O	MFP9	I2C1 data input/output pin.
			EPWM0_CH5	I/O	MFP11	EPWM0 channel 5 output/capture input.
			EPWM1_CH5	I/O	MFP12	EPWM1 channel 5 output/capture input.
			EPWM0_BRAKE1	I	MFP13	EPWM0 Brake 1 input pin.
		11	V _{SS}	P	MFP0	Ground pin for digital circuit.
		12	V _{DD}	P	MFP0	Power supply for I/O ports and LDO source for internal PLL and digital circuit.
8	8	13	PA.11	I/O	MFP0	General purpose digital I/O pin.
			ACMP0_P0	A	MFP1	Analog comparator 0 positive input 0 pin.
			EBI_nRD	O	MFP2	EBI read enable output pin.
			SC2_PWR	O	MFP3	Smart Card 2 power pin.
			SPI2_SS	I/O	MFP4	SPI2 slave select pin.
			SD1_DAT3	I/O	MFP5	SD/SDIO1 data line bit 3.
			USCI0_CLK	I/O	MFP6	USCI0 clock pin.
			I2C2_SCL	I/O	MFP7	I2C2 clock pin.
			BPWM0_CH0	I/O	MFP9	BPWM0 channel 0 output/capture input.
			EPWM0_SYNC_OUT	O	MFP10	EPWM0 counter synchronous trigger output pin.
			TM0_EXT	I/O	MFP13	Timer0 external capture input/toggle output pin.
			DAC1_ST	I	MFP14	DAC1 external trigger input.
9	9	14	PA.10	I/O	MFP0	General purpose digital I/O pin.
			ACMP1_P0	A	MFP1	Analog comparator 1 positive input 0 pin.
			OPA1_O	A	MFP1	Operational amplifier 1 output pin.
			EBI_nWR	O	MFP2	EBI write enable output pin.
			SC2_RST	O	MFP3	Smart Card 2 reset pin.
			SPI2_CLK	I/O	MFP4	SPI2 serial clock pin.
			SD1_DAT2	I/O	MFP5	SD/SDIO1 data line bit 2.
						USCI0_DAT0

64 Pin	64 Pin 2 USB	128 Pin	Pin Name	Type	MFP	Description
			I2C2_SDA	I/O	MFP7	I2C2 data input/output pin.
			BPWM0_CH1	I/O	MFP9	BPWM0 channel 1 output/capture input.
			QE1_INDEX	I	MFP10	Quadrature encoder 1 index input
			ECAP0_IC0	I	MFP11	Enhanced capture unit 0 input 0 pin.
			TM1_EXT	I/O	MFP13	Timer1 external capture input/toggle output pin.
			DAC0_ST	I	MFP14	DAC0 external trigger input.
10	10	15	PA.9	I/O	MFP0	General purpose digital I/O pin.
			OPA1_N	A	MFP1	Operational amplifier 1 negative input pin.
			EBI_MCLK	O	MFP2	EBI external clock output pin.
			SC2_DAT	I/O	MFP3	Smart Card 2 data pin.
			SPI2_MISO	I/O	MFP4	SPI2 MISO (Master In, Slave Out) pin.
			SD1_DAT1	I/O	MFP5	SD/SDIO1 data line bit 1.
			USCI0_DAT1	I/O	MFP6	USCI0 data 1 pin.
			UART1_TXD	O	MFP7	UART1 data transmitter output pin.
			BPWM0_CH2	I/O	MFP9	BPWM0 channel 2 output/capture input.
			QE1_A	I	MFP10	Quadrature encoder 1 phase A input
			ECAP0_IC1	I	MFP11	Enhanced capture unit 0 input 1 pin.
			TM2_EXT	I/O	MFP13	Timer2 external capture input/toggle output pin.
11	11	16	PA.8	I/O	MFP0	General purpose digital I/O pin.
			OPA1_P	A	MFP1	Operational amplifier 1 positive input pin.
			EBI_ALE	O	MFP2	EBI address latch enable output pin.
			SC2_CLK	O	MFP3	Smart Card 2 clock pin.
			SPI2_MOSI	I/O	MFP4	SPI2 MOSI (Master Out, Slave In) pin.
			SD1_DAT0	I/O	MFP5	SD/SDIO1 data line bit 0.
			USCI0_CTL1	I/O	MFP6	USCI0 control 1 pin.
			UART1_RXD	I	MFP7	UART1 data receiver input pin.
			BPWM0_CH3	I/O	MFP9	BPWM0 channel 3 output/capture input.
			QE1_B	I	MFP10	Quadrature encoder 1 phase B input
			ECAP0_IC2	I	MFP11	Enhanced capture unit 0 input 2 pin.
			TM3_EXT	I/O	MFP13	Timer3 external capture input/toggle output pin.
			INT4	I	MFP15	External interrupt 4 input pin.
		17	PC.13	I/O	MFP0	General purpose digital I/O pin.
			EBI_ADR10	O	MFP2	EBI address bus bit 10.
			SC2_nCD	I	MFP3	Smart Card 2 card detect pin.

64 Pin	64 Pin 2 USB	128 Pin	Pin Name	Type	MFP	Description
			SPI2_I2SMCLK	I/O	MFP4	SPI2 I2S master clock output pin
			USCI0_CTL0	I/O	MFP6	USCI0 control 0 pin.
			UART2_TXD	O	MFP7	UART2 data transmitter output pin.
			BPWM0_CH4	I/O	MFP9	BPWM0 channel 4 output/capture input.
			CLKO	O	MFP13	Clock Out
			EADC0_ST	I	MFP14	EADC0 external trigger input.
		18	PD.12	I/O	MFP0	General purpose digital I/O pin.
			OPA2_O	A	MFP1	Operational amplifier 2 output pin.
			EBI_nCS0	O	MFP2	EBI chip select 0 output pin.
			UART2_RXD	I	MFP7	UART2 data receiver input pin.
			BPWM0_CH5	I/O	MFP9	BPWM0 channel 5 output/capture input.
			QEIO_INDEX	I	MFP10	Quadrature encoder 0 index input
			CLKO	O	MFP13	Clock Out
			EADC0_ST	I	MFP14	EADC0 external trigger input.
			INT5	I	MFP15	External interrupt 5 input pin.
		19	PD.11	I/O	MFP0	General purpose digital I/O pin.
			OPA2_N	A	MFP1	Operational amplifier 2 negative input pin.
			EBI_nCS1	O	MFP2	EBI chip select 1 output pin.
			UART1_TXD	O	MFP3	UART1 data transmitter output pin.
			QEIO_A	I	MFP10	Quadrature encoder 0 phase A input
			INT6	I	MFP15	External interrupt 6 input pin.
		20	PD.10	I/O	MFP0	General purpose digital I/O pin.
			OPA2_P	A	MFP1	Operational amplifier 2 positive input pin.
			EBI_nCS2	O	MFP2	EBI chip select 2 output pin.
			UART1_RXD	I	MFP3	UART1 data receiver input pin.
			QEIO_B	I	MFP10	Quadrature encoder 0 phase B input
			INT7	I	MFP15	External interrupt 7 input pin.
		21	PG.2	I/O	MFP0	General purpose digital I/O pin.
			EBI_ADR11	O	MFP2	EBI address bus bit 11.
			SPI2_SS	I/O	MFP3	SPI2 slave select pin.
			I2C0_SMBAL	O	MFP4	I2C0 SMBus SMBALTER pin
			I2C1_SCL	I/O	MFP5	I2C1 clock pin.
			TM0	I/O	MFP13	Timer0 event counter input/toggle output pin.
		22	PG.3	I/O	MFP0	General purpose digital I/O pin.

64 Pin	64 Pin 2 USB	128 Pin	Pin Name	Type	MFP	Description
			EBI_ADR12	O	MFP2	EBI address bus bit 12.
			SPI2_CLK	I/O	MFP3	SPI2 serial clock pin.
			I2C0_SMBSUS	O	MFP4	I2C0 SMBus SMBSUS pin (PMBus CONTROL pin)
			I2C1_SDA	I/O	MFP5	I2C1 data input/output pin.
			TM1	I/O	MFP13	Timer1 event counter input/toggle output pin.
		23	PG.4	I/O	MFP0	General purpose digital I/O pin.
			EBI_ADR13	O	MFP2	EBI address bus bit 13.
			SPI2_MISO	I/O	MFP3	SPI2 MISO (Master In, Slave Out) pin.
			TM2	I/O	MFP13	Timer2 event counter input/toggle output pin.
		24	PF.11	I/O	MFP0	General purpose digital I/O pin.
			EBI_ADR14	O	MFP2	EBI address bus bit 14.
			SPI2_MOSI	I/O	MFP3	SPI2 MOSI (Master Out, Slave In) pin.
			TAMPER5	I/O	MFP10	TAMPER detector loop pin 5.
			TM3	I/O	MFP13	Timer3 event counter input/toggle output pin.
		25	PF.10	I/O	MFP0	General purpose digital I/O pin.
			EBI_ADR15	O	MFP2	EBI address bus bit 15.
			SC0_nCD	I	MFP3	Smart Card 0 card detect pin.
			I2S0_BCLK	O	MFP4	I2S0 bit clock output pin.
			SPI0_I2SMCLK	I/O	MFP5	SPI0 I2S master clock output pin
			TAMPER4	I/O	MFP10	TAMPER detector loop pin 4.
		26	PF.9	I/O	MFP0	General purpose digital I/O pin.
			EBI_ADR16	O	MFP2	EBI address bus bit 16.
			SC0_PWR	O	MFP3	Smart Card 0 power pin.
			I2S0_MCLK	O	MFP4	I2S0 master clock output pin.
			SPI0_SS	I/O	MFP5	SPI0 slave select pin.
			TAMPER3	I/O	MFP10	TAMPER detector loop pin 3.
		27	PF.8	I/O	MFP0	General purpose digital I/O pin.
			EBI_ADR17	O	MFP2	EBI address bus bit 17.
			SC0_RST	O	MFP3	Smart Card 0 reset pin.
			I2S0_DI	I	MFP4	I2S0 data input pin.
			SPI0_CLK	I/O	MFP5	SPI0 serial clock pin.
			TAMPER2	I/O	MFP10	TAMPER detector loop pin 2.
		28	PF.7	I/O	MFP0	General purpose digital I/O pin.
			EBI_ADR18	O	MFP2	EBI address bus bit 18.

64 Pin	64 Pin 2 USB	128 Pin	Pin Name	Type	MFP	Description
			SC0_DAT	I/O	MFP3	Smart Card 0 data pin.
			I2S0_DO	O	MFP4	I2S0 data output pin.
			SPI0_MISO	I/O	MFP5	SPI0 MISO (Master In, Slave Out) pin.
			UART4_TXD	O	MFP6	UART4 data transmitter output pin.
			TAMPER1	I/O	MFP10	TAMPER detector loop pin 1.
12	12	29	PF.6	I/O	MFP0	General purpose digital I/O pin.
			EBI_ADR19	O	MFP2	EBI address bus bit 19.
			SC0_CLK	O	MFP3	Smart Card 0 clock pin.
			I2S0_LRCK	O	MFP4	I2S0 left right channel clock output pin.
			SPI0_MOSI	I/O	MFP5	SPI0 MOSI (Master Out, Slave In) pin.
			UART4_RXD	I	MFP6	UART4 data receiver input pin.
			EBI_nCS0	O	MFP7	EBI chip select 0 output pin.
			TAMPER0	I/O	MFP10	TAMPER detector loop pin 0.
13	13	30	V _{DD}	P	MFP0	Power supply for I/O ports and LDO source for internal PLL and digital circuit.
14	14	31	PF.5	I/O	MFP0	General purpose digital I/O pin.
			UART2_RXD	I	MFP2	UART2 data receiver input pin.
			UART2_nCTS	I	MFP4	UART2 clear to Send input pin.
			BPWM0_CH4	I/O	MFP8	BPWM0 channel 4 output/capture input.
			EPWM0_SYNC_OUT	O	MFP9	EPWM0 counter synchronous trigger output pin.
			X32_IN	I	MFP10	External 32.768 kHz crystal input pin.
			EADC0_ST	I	MFP11	EADC0 external trigger input.
15	15	32	PF.4	I/O	MFP0	General purpose digital I/O pin.
			UART2_TXD	O	MFP2	UART2 data transmitter output pin.
			UART2_nRTS	O	MFP4	UART2 request to Send output pin.
			BPWM0_CH5	I/O	MFP8	BPWM0 channel 5 output/capture input.
			X32_OUT	O	MFP10	External 32.768 kHz crystal output pin.
		33	PH.4	I/O	MFP0	General purpose digital I/O pin.
			EBI_ADR3	O	MFP2	EBI address bus bit 3.
			SPI1_MISO	I/O	MFP3	SPI1 MISO (Master In, Slave Out) pin.
		34	PH.5	I/O	MFP0	General purpose digital I/O pin.
			EBI_ADR2	O	MFP2	EBI address bus bit 2.
			SPI1_MOSI	I/O	MFP3	SPI1 MOSI (Master Out, Slave In) pin.
		35	PH.6	I/O	MFP0	General purpose digital I/O pin.

64 Pin	64 Pin 2 USB	128 Pin	Pin Name	Type	MFP	Description
			EBI_ADR1	O	MFP2	EBI address bus bit 1.
			SPI1_CLK	I/O	MFP3	SPI1 serial clock pin.
		36	PH.7	I/O	MFP0	General purpose digital I/O pin.
			EBI_ADR0	O	MFP2	EBI address bus bit 0.
			SPI1_SS	I/O	MFP3	SPI1 slave select pin.
16	16	37	PF.3	I/O	MFP0	General purpose digital I/O pin.
			EBI_nCS0	O	MFP2	EBI chip select 0 output pin.
			UART0_TXD	O	MFP3	UART0 data transmitter output pin.
			I2C0_SCL	I/O	MFP4	I2C0 clock pin.
			XT1_IN	I	MFP10	External 4~24 MHz (high speed) crystal input pin.
			BPWM1_CH0	I/O	MFP11	BPWM1 channel 0 output/capture input.
17	17	38	PF.2	I/O	MFP0	General purpose digital I/O pin.
			EBI_nCS1	O	MFP2	EBI chip select 1 output pin.
			UART0_RXD	I	MFP3	UART0 data receiver input pin.
			I2C0_SDA	I/O	MFP4	I2C0 data input/output pin.
			QSPI0_CLK	I/O	MFP5	Quad SPI0 serial clock pin.
			XT1_OUT	O	MFP10	External 4~24 MHz (high speed) crystal output pin.
			BPWM1_CH1	I/O	MFP11	BPWM1 channel 1 output/capture input.
		39	V _{SS}	P	MFP0	Ground pin for digital circuit.
		40	V _{DD}	P	MFP0	Power supply for I/O ports and LDO source for internal PLL and digital circuit.
		41	PE.8	I/O	MFP0	General purpose digital I/O pin.
			EBI_ADR10	O	MFP2	EBI address bus bit 10.
			I2S0_BCLK	O	MFP4	I2S0 bit clock output pin.
			SPI2_CLK	I/O	MFP5	SPI2 serial clock pin.
			USCI1_CTL1	I/O	MFP6	USCI1 control 1 pin.
			UART2_TXD	O	MFP7	UART2 data transmitter output pin.
			EPWM0_CH0	I/O	MFP10	EPWM0 channel 0 output/capture input.
			EPWM0_BRAKE0	I	MFP11	EPWM0 Brake 0 input pin.
			ECAP0_IC0	I	MFP12	Enhanced capture unit 0 input 0 pin.
			TRACE_CLK	O	MFP14	ETM Trace Clock output pin
		42	PE.9	I/O	MFP0	General purpose digital I/O pin.
			EBI_ADR11	O	MFP2	EBI address bus bit 11.
			I2S0_MCLK	O	MFP4	I2S0 master clock output pin.

64 Pin	64 Pin 2 USB	128 Pin	Pin Name	Type	MFP	Description
			SPI2_MISO	I/O	MFP5	SPI2 MISO (Master In, Slave Out) pin.
			USCI1_CTL0	I/O	MFP6	USCI1 control 0 pin.
			UART2_RXD	I	MFP7	UART2 data receiver input pin.
			EPWM0_CH1	I/O	MFP10	EPWM0 channel 1 output/capture input.
			EPWM0_BRAKE1	I	MFP11	EPWM0 Brake 1 input pin.
			ECAP0_IC1	I	MFP12	Enhanced capture unit 0 input 1 pin.
			TRACE_DATA0	O	MFP14	ETM Trace Data 0 output pin
		43	PE.10	I/O	MFP0	General purpose digital I/O pin.
			EBI_ADR12	O	MFP2	EBI address bus bit 12.
			I2S0_DI	I	MFP4	I2S0 data input pin.
			SPI2_MOSI	I/O	MFP5	SPI2 MOSI (Master Out, Slave In) pin.
			USCI1_DAT0	I/O	MFP6	USCI1 data 0 pin.
			UART3_TXD	O	MFP7	UART3 data transmitter output pin.
			EPWM0_CH2	I/O	MFP10	EPWM0 channel 2 output/capture input.
			EPWM1_BRAKE0	I	MFP11	EPWM1 Brake 0 input pin.
			ECAP0_IC2	I	MFP12	Enhanced capture unit 0 input 2 pin.
			TRACE_DATA1	O	MFP14	ETM Trace Data 1 output pin
		44	PE.11	I/O	MFP0	General purpose digital I/O pin.
			EBI_ADR13	O	MFP2	EBI address bus bit 13.
			I2S0_DO	O	MFP4	I2S0 data output pin.
			SPI2_SS	I/O	MFP5	SPI2 slave select pin.
			USCI1_DAT1	I/O	MFP6	USCI1 data 1 pin.
			UART3_RXD	I	MFP7	UART3 data receiver input pin.
			UART1_nCTS	I	MFP8	UART1 clear to Send input pin.
			EPWM0_CH3	I/O	MFP10	EPWM0 channel 3 output/capture input.
			EPWM1_BRAKE1	I	MFP11	EPWM1 Brake 1 input pin.
			ECAP1_IC2	I	MFP13	Enhanced capture unit 1 input 2 pin.
			TRACE_DATA2	O	MFP14	ETM Trace Data 2 output pin
		45	PE.12	I/O	MFP0	General purpose digital I/O pin.
			EBI_ADR14	O	MFP2	EBI address bus bit 14.
			I2S0_LRCK	O	MFP4	I2S0 left right channel clock output pin.
			SPI2_I2SMCLK	I/O	MFP5	SPI2 I2S master clock output pin
			USCI1_CLK	I/O	MFP6	USCI1 clock pin.
			UART1_nRTS	O	MFP8	UART1 request to Send output pin.

64 Pin	64 Pin 2 USB	128 Pin	Pin Name	Type	MFP	Description
			EPWM0_CH4	I/O	MFP10	EPWM0 channel 4 output/capture input.
			ECAP1_IC1	I	MFP13	Enhanced capture unit 1 input 1 pin.
			TRACE_DATA3	O	MFP14	ETM Trace Data 3 output pin
		46	PE.13	I/O	MFP0	General purpose digital I/O pin.
			EBI_ADR15	O	MFP2	EBI address bus bit 15.
			I2C0_SCL	I/O	MFP4	I2C0 clock pin.
			UART4_nRTS	O	MFP5	UART4 request to Send output pin.
			UART1_TXD	O	MFP8	UART1 data transmitter output pin.
			EPWM0_CH5	I/O	MFP10	EPWM0 channel 5 output/capture input.
			EPWM1_CH0	I/O	MFP11	EPWM1 channel 0 output/capture input.
			BPWM1_CH5	I/O	MFP12	BPWM1 channel 5 output/capture input.
			ECAP1_IC0	I	MFP13	Enhanced capture unit 1 input 0 pin.
		47	PC.8	I/O	MFP0	General purpose digital I/O pin.
			EBI_ADR16	O	MFP2	EBI address bus bit 16.
			I2C0_SDA	I/O	MFP4	I2C0 data input/output pin.
			UART4_nCTS	I	MFP5	UART4 clear to Send input pin.
			UART1_RXD	I	MFP8	UART1 data receiver input pin.
			EPWM1_CH1	I/O	MFP11	EPWM1 channel 1 output/capture input.
			BPWM1_CH4	I/O	MFP12	BPWM1 channel 4 output/capture input.
18	18	48	PC.7	I/O	MFP0	General purpose digital I/O pin.
			EBI_AD9	I/O	MFP2	EBI address/data bus bit 9.
			SPI1_MISO	I/O	MFP4	SPI1 MISO (Master In, Slave Out) pin.
			UART4_TXD	O	MFP5	UART4 data transmitter output pin.
			SC2_PWR	O	MFP6	Smart Card 2 power pin.
			UART0_nCTS	I	MFP7	UART0 clear to Send input pin.
			I2C1_SMBAL	O	MFP8	I2C1 SMBus SMBALTER pin
			EPWM1_CH2	I/O	MFP11	EPWM1 channel 2 output/capture input.
			BPWM1_CH0	I/O	MFP12	BPWM1 channel 0 output/capture input.
			TM0	I/O	MFP14	Timer0 event counter input/toggle output pin.
			INT3	I	MFP15	External interrupt 3 input pin.
19	19	49	PC.6	I/O	MFP0	General purpose digital I/O pin.
			EBI_AD8	I/O	MFP2	EBI address/data bus bit 8.
			SPI1_MOSI	I/O	MFP4	SPI1 MOSI (Master Out, Slave In) pin.
			UART4_RXD	I	MFP5	UART4 data receiver input pin.

64 Pin	64 Pin 2 USB	128 Pin	Pin Name	Type	MFP	Description
			SC2_RST	O	MFP6	Smart Card 2 reset pin.
			UART0_nRTS	O	MFP7	UART0 request to Send output pin.
			I2C1_SMBSUS	O	MFP8	I2C1 SMBus SMBSUS pin (PMBus CONTROL pin)
			EPWM1_CH3	I/O	MFP11	EPWM1 channel 3 output/capture input.
			BPWM1_CH1	I/O	MFP12	BPWM1 channel 1 output/capture input.
			TM1	I/O	MFP14	Timer1 event counter input/toggle output pin.
			INT2	I	MFP15	External interrupt 2 input pin.
20	20	50	PA.7	I/O	MFP0	General purpose digital I/O pin.
			EBI_AD7	I/O	MFP2	EBI address/data bus bit 7.
			SPI1_CLK	I/O	MFP4	SPI1 serial clock pin.
			SC2_DAT	I/O	MFP6	Smart Card 2 data pin.
			UART0_TXD	O	MFP7	UART0 data transmitter output pin.
			I2C1_SCL	I/O	MFP8	I2C1 clock pin.
			EPWM1_CH4	I/O	MFP11	EPWM1 channel 4 output/capture input.
			BPWM1_CH2	I/O	MFP12	BPWM1 channel 2 output/capture input.
			ACMP0_WLAT	I	MFP13	Analog comparator 0 window latch input pin
			TM2	I/O	MFP14	Timer2 event counter input/toggle output pin.
			INT1	I	MFP15	External interrupt 1 input pin.
21	21	51	PA.6	I/O	MFP0	General purpose digital I/O pin.
			EBI_AD6	I/O	MFP2	EBI address/data bus bit 6.
			SPI1_SS	I/O	MFP4	SPI1 slave select pin.
			SD1_nCD	I	MFP5	SD/SDIO1 card detect input pin
			SC2_CLK	O	MFP6	Smart Card 2 clock pin.
			UART0_RXD	I	MFP7	UART0 data receiver input pin.
			I2C1_SDA	I/O	MFP8	I2C1 data input/output pin.
			EPWM1_CH5	I/O	MFP11	EPWM1 channel 5 output/capture input.
			BPWM1_CH3	I/O	MFP12	BPWM1 channel 3 output/capture input.
			ACMP1_WLAT	I	MFP13	Analog comparator 1 window latch input pin
			TM3	I/O	MFP14	Timer3 event counter input/toggle output pin.
			INT0	I	MFP15	External interrupt 0 input pin.
22	22	52	V _{SS}	P	MFP0	Ground pin for digital circuit.
23	23	53	V _{DD}	P	MFP0	Power supply for I/O ports and LDO source for internal PLL and digital circuit.
24	24	54	LDO_CAP	A	MFP0	LDO output pin.

64 Pin	64 Pin 2 USB	128 Pin	Pin Name	Type	MFP	Description
25	25	55	PA.5	I/O	MFP0	General purpose digital I/O pin.
			SPIM_D2	I/O	MFP2	SPIM data 2 pin for Quad Mode I/O.
			QSPI0_MISO1	I/O	MFP3	Quad SPI0 MISO1 (Master In, Slave Out) pin.
			SPI1_I2SMCLK	I/O	MFP4	SPI1 I2S master clock output pin
			SD1_CMD	I/O	MFP5	SD/SDIO1 command/response pin
			SC2_nCD	I	MFP6	Smart Card 2 card detect pin.
			UART0_nCTS	I	MFP7	UART0 clear to Send input pin.
			UART5_TXD	O	MFP8	UART5 data transmitter output pin.
			I2C0_SCL	I/O	MFP9	I2C0 clock pin.
			BPWM0_CH5	I/O	MFP12	BPWM0 channel 5 output/capture input.
			EPWM0_CH0	I/O	MFP13	EPWM0 channel 0 output/capture input.
			QEIO_INDEX	I	MFP14	Quadrature encoder 0 index input
26	26	56	PA.4	I/O	MFP0	General purpose digital I/O pin.
			SPIM_D3	I/O	MFP2	SPIM data 3 pin for Quad Mode I/O.
			QSPI0_MOSI1	I/O	MFP3	Quad SPI0 MOSI1 (Master Out, Slave In) pin.
			SPI0_I2SMCLK	I/O	MFP4	SPI0 I2S master clock output pin
			SD1_CLK	O	MFP5	SD/SDIO1 clock output pin
			SC0_nCD	I	MFP6	Smart Card 0 card detect pin.
			UART0_nRTS	O	MFP7	UART0 request to Send output pin.
			UART5_RXD	I	MFP8	UART5 data receiver input pin.
			I2C0_SDA	I/O	MFP9	I2C0 data input/output pin.
			BPWM0_CH4	I/O	MFP12	BPWM0 channel 4 output/capture input.
			EPWM0_CH1	I/O	MFP13	EPWM0 channel 1 output/capture input.
			QEIO_A	I	MFP14	Quadrature encoder 0 phase A input
27	27	57	PA.3	I/O	MFP0	General purpose digital I/O pin.
			SPIM_SS	I/O	MFP2	SPIM slave select pin.
			QSPI0_SS	I/O	MFP3	Quad SPI0 slave select pin.
			SPI0_SS	I/O	MFP4	SPI0 slave select pin.
			SD1_DAT3	I/O	MFP5	SD/SDIO1 data line bit 3.
			SC0_PWR	O	MFP6	Smart Card 0 power pin.
			UART4_TXD	O	MFP7	UART4 data transmitter output pin.
			UART1_TXD	O	MFP8	UART1 data transmitter output pin.
			I2C1_SCL	I/O	MFP9	I2C1 clock pin.
			BPWM0_CH3	I/O	MFP12	BPWM0 channel 3 output/capture input.

64 Pin	64 Pin 2 USB	128 Pin	Pin Name	Type	MFP	Description
			EPWM0_CH2	I/O	MFP13	EPWM0 channel 2 output/capture input.
			QEIO_B	I	MFP14	Quadrature encoder 0 phase B input
28	28	58	PA.2	I/O	MFP0	General purpose digital I/O pin.
			SPIM_CLK	I/O	MFP2	SPIM serial clock pin.
			QSPI0_CLK	I/O	MFP3	Quad SPI0 serial clock pin.
			SPI0_CLK	I/O	MFP4	SPI0 serial clock pin.
			SD1_DAT2	I/O	MFP5	SD/SDIO1 data line bit 2.
			SC0_RST	O	MFP6	Smart Card 0 reset pin.
			UART4_RXD	I	MFP7	UART4 data receiver input pin.
			UART1_RXD	I	MFP8	UART1 data receiver input pin.
			I2C1_SDA	I/O	MFP9	I2C1 data input/output pin.
			BPWM0_CH2	I/O	MFP12	BPWM0 channel 2 output/capture input.
			EPWM0_CH3	I/O	MFP13	EPWM0 channel 3 output/capture input.
29	29	59	PA.1	I/O	MFP0	General purpose digital I/O pin.
			SPIM_MISO	I/O	MFP2	SPIM MISO (Master In, Slave Out) pin.
			QSPI0_MISO0	I/O	MFP3	Quad SPI0 MISO0 (Master In, Slave Out) pin.
			SPI0_MISO	I/O	MFP4	SPI0 MISO (Master In, Slave Out) pin.
			SD1_DAT1	I/O	MFP5	SD/SDIO1 data line bit 1.
			SC0_DAT	I/O	MFP6	Smart Card 0 data pin.
			UART0_TXD	O	MFP7	UART0 data transmitter output pin.
			UART1_nCTS	I	MFP8	UART1 clear to Send input pin.
			I2C2_SCL	I/O	MFP9	I2C2 clock pin.
			BPWM0_CH1	I/O	MFP12	BPWM0 channel 1 output/capture input.
			EPWM0_CH4	I/O	MFP13	EPWM0 channel 4 output/capture input.
			DAC1_ST	I	MFP15	DAC1 external trigger input.
30	30	60	PA.0	I/O	MFP0	General purpose digital I/O pin.
			SPIM_MOSI	I/O	MFP2	SPIM MOSI (Master Out, Slave In) pin.
			QSPI0_MOSI0	I/O	MFP3	Quad SPI0 MOSI0 (Master Out, Slave In) pin.
			SPI0_MOSI	I/O	MFP4	SPI0 MOSI (Master Out, Slave In) pin.
			SD1_DAT0	I/O	MFP5	SD/SDIO1 data line bit 0.
			SC0_CLK	O	MFP6	Smart Card 0 clock pin.
			UART0_RXD	I	MFP7	UART0 data receiver input pin.
			UART1_nRTS	O	MFP8	UART1 request to Send output pin.
			I2C2_SDA	I/O	MFP9	I2C2 data input/output pin.

64 Pin	64 Pin 2 USB	128 Pin	Pin Name	Type	MFP	Description
			BPWM0_CH0	I/O	MFP12	BPWM0 channel 0 output/capture input.
			EPWM0_CH5	I/O	MFP13	EPWM0 channel 5 output/capture input.
			DAC0_ST	I	MFP15	DAC0 external trigger input.
31	31	61	V _{DDIO}	P	MFP0	Power supply for PA.0~PA.5.
		62	PE.14	I/O	MFP0	General purpose digital I/O pin.
			EBI_AD8	I/O	MFP2	EBI address/data bus bit 8.
			UART2_TXD	O	MFP3	UART2 data transmitter output pin.
			SD1_nCD	I	MFP5	SD/SDIO1 card detect input pin
		63	PE.15	I/O	MFP0	General purpose digital I/O pin.
			EBI_AD9	I/O	MFP2	EBI address/data bus bit 9.
			UART2_RXD	I	MFP3	UART2 data receiver input pin.
32	32	64	nRESET	I	MFP0	External reset input: active LOW, with an internal pull-up. Set this pin low reset to initial state.
33	33	65	PF.0	I/O	MFP0	General purpose digital I/O pin.
			UART1_TXD	O	MFP2	UART1 data transmitter output pin.
			I2C1_SCL	I/O	MFP3	I2C1 clock pin.
			BPWM1_CH0	I/O	MFP12	BPWM1 channel 0 output/capture input.
			ICE_DAT	O	MFP14	Serial wired debugger data pin.
34	34	66	PF.1	I/O	MFP0	General purpose digital I/O pin.
			UART1_RXD	I	MFP2	UART1 data receiver input pin.
			I2C1_SDA	I/O	MFP3	I2C1 data input/output pin.
			BPWM1_CH1	I/O	MFP12	BPWM1 channel 1 output/capture input.
			ICE_CLK	I	MFP14	Serial wired debugger clock pin.
		67	PD.9	I/O	MFP0	General purpose digital I/O pin.
			EBI_AD7	I/O	MFP2	EBI address/data bus bit 7.
			I2C2_SCL	I/O	MFP3	I2C2 clock pin.
			UART2_nCTS	I	MFP4	UART2 clear to Send input pin.
		68	PD.8	I/O	MFP0	General purpose digital I/O pin.
			EBI_AD6	I/O	MFP2	EBI address/data bus bit 6.
			I2C2_SDA	I/O	MFP3	I2C2 data input/output pin.
			UART2_nRTS	O	MFP4	UART2 request to Send output pin.
35		69	PC.5	I/O	MFP0	General purpose digital I/O pin.
			EBI_AD5	I/O	MFP2	EBI address/data bus bit 5.
			SPIM_D2	I/O	MFP3	SPIM data 2 pin for Quad Mode I/O.

64 Pin	64 Pin 2 USB	128 Pin	Pin Name	Type	MFP	Description
			QSPI0_MISO1	I/O	MFP4	Quad SPI0 MISO1 (Master In, Slave Out) pin.
			UART2_TXD	O	MFP8	UART2 data transmitter output pin.
			I2C1_SCL	I/O	MFP9	I2C1 clock pin.
			UART4_TXD	O	MFP11	UART4 data transmitter output pin.
			EPWM1_CH0	I/O	MFP12	EPWM1 channel 0 output/capture input.
36		70	PC.4	I/O	MFP0	General purpose digital I/O pin.
			EBI_AD4	I/O	MFP2	EBI address/data bus bit 4.
			SPIM_D3	I/O	MFP3	SPIM data 3 pin for Quad Mode I/O.
			QSPI0_MOSI1	I/O	MFP4	Quad SPI0 MOSI1 (Master Out, Slave In) pin.
			SC1_nCD	I	MFP5	Smart Card 1 card detect pin.
			I2S0_BCLK	O	MFP6	I2S0 bit clock output pin.
			SPI1_I2SMCLK	I/O	MFP7	SPI1 I2S master clock output pin
			UART2_RXD	I	MFP8	UART2 data receiver input pin.
			I2C1_SDA	I/O	MFP9	I2C1 data input/output pin.
			UART4_RXD	I	MFP11	UART4 data receiver input pin.
			EPWM1_CH1	I/O	MFP12	EPWM1 channel 1 output/capture input.
37		71	PC.3	I/O	MFP0	General purpose digital I/O pin.
			EBI_AD3	I/O	MFP2	EBI address/data bus bit 3.
			SPIM_SS	I/O	MFP3	SPIM slave select pin.
			QSPI0_SS	I/O	MFP4	Quad SPI0 slave select pin.
			SC1_PWR	O	MFP5	Smart Card 1 power pin.
			I2S0_MCLK	O	MFP6	I2S0 master clock output pin.
			SPI1_MISO	I/O	MFP7	SPI1 MISO (Master In, Slave Out) pin.
			UART2_nRTS	O	MFP8	UART2 request to Send output pin.
			I2C0_SMBAL	O	MFP9	I2C0 SMBus SMBALTER pin
			UART3_TXD	O	MFP11	UART3 data transmitter output pin.
			EPWM1_CH2	I/O	MFP12	EPWM1 channel 2 output/capture input.
38		72	PC.2	I/O	MFP0	General purpose digital I/O pin.
			EBI_AD2	I/O	MFP2	EBI address/data bus bit 2.
			SPIM_CLK	I/O	MFP3	SPIM serial clock pin.
			QSPI0_CLK	I/O	MFP4	Quad SPI0 serial clock pin.
			SC1_RST	O	MFP5	Smart Card 1 reset pin.
			I2S0_DI	I	MFP6	I2S0 data input pin.
			SPI1_MOSI	I/O	MFP7	SPI1 MOSI (Master Out, Slave In) pin.

64 Pin	64 Pin 2 USB	128 Pin	Pin Name	Type	MFP	Description
			UART2_nCTS	I	MFP8	UART2 clear to Send input pin.
			I2C0_SMBSUS	O	MFP9	I2C0 SMBus SMBSUS pin (PMBus CONTROL pin)
			UART3_RXD	I	MFP11	UART3 data receiver input pin.
			EPWM1_CH3	I/O	MFP12	EPWM1 channel 3 output/capture input.
39	35	73	PC.1	I/O	MFP0	General purpose digital I/O pin.
			EBI_AD1	I/O	MFP2	EBI address/data bus bit 1.
			SPIM_MISO	I/O	MFP3	SPIM MISO (Master In, Slave Out) pin.
			QSPI0_MISO0	I/O	MFP4	Quad SPI0 MISO0 (Master In, Slave Out) pin.
			SC1_DAT	I/O	MFP5	Smart Card 1 data pin.
			I2S0_DO	O	MFP6	I2S0 data output pin.
			SPI1_CLK	I/O	MFP7	SPI1 serial clock pin.
			UART2_TXD	O	MFP8	UART2 data transmitter output pin.
			I2C0_SCL	I/O	MFP9	I2C0 clock pin.
			EPWM1_CH4	I/O	MFP12	EPWM1 channel 4 output/capture input.
			ACMP0_O	O	MFP14	Analog comparator 0 output pin.
40	36	74	PC.0	I/O	MFP0	General purpose digital I/O pin.
			EBI_AD0	I/O	MFP2	EBI address/data bus bit 0.
			SPIM_MOSI	I/O	MFP3	SPIM MOSI (Master Out, Slave In) pin.
			QSPI0_MOSI0	I/O	MFP4	Quad SPI0 MOSI0 (Master Out, Slave In) pin.
			SC1_CLK	O	MFP5	Smart Card 1 clock pin.
			I2S0_LRCK	O	MFP6	I2S0 left right channel clock output pin.
			SPI1_SS	I/O	MFP7	SPI1 slave select pin.
			UART2_RXD	I	MFP8	UART2 data receiver input pin.
			I2C0_SDA	I/O	MFP9	I2C0 data input/output pin.
			EPWM1_CH5	I/O	MFP12	EPWM1 channel 5 output/capture input.
			ACMP1_O	O	MFP14	Analog comparator 1 output pin.
		75	V _{SS}	P	MFP0	Ground pin for digital circuit.
		76	V _{DD}	P	MFP0	Power supply for I/O ports and LDO source for internal PLL and digital circuit.
		77	PG.9	I/O	MFP0	General purpose digital I/O pin.
			EBI_AD0	I/O	MFP2	EBI address/data bus bit 0.
			SD1_DAT3	I/O	MFP3	SD/SDIO1 data line bit 3.
			SPIM_D2	I/O	MFP4	SPIM data 2 pin for Quad Mode I/O.
			BPWM0_CH5	I/O	MFP12	BPWM0 channel 5 output/capture input.

64 Pin	64 Pin 2 USB	128 Pin	Pin Name	Type	MFP	Description
		78	PG.10	I/O	MFP0	General purpose digital I/O pin.
			EBI_AD1	I/O	MFP2	EBI address/data bus bit 1.
			SD1_DAT2	I/O	MFP3	SD/SDIO1 data line bit 2.
			SPIM_D3	I/O	MFP4	SPIM data 3 pin for Quad Mode I/O.
			BPWM0_CH4	I/O	MFP12	BPWM0 channel 4 output/capture input.
		79	PG.11	I/O	MFP0	General purpose digital I/O pin.
			EBI_AD2	I/O	MFP2	EBI address/data bus bit 2.
			SD1_DAT1	I/O	MFP3	SD/SDIO1 data line bit 1.
			SPIM_SS	I/O	MFP4	SPIM slave select pin.
			BPWM0_CH3	I/O	MFP12	BPWM0 channel 3 output/capture input.
		80	PG.12	I/O	MFP0	General purpose digital I/O pin.
			EBI_AD3	I/O	MFP2	EBI address/data bus bit 3.
			SD1_DAT0	I/O	MFP3	SD/SDIO1 data line bit 0.
			SPIM_CLK	I/O	MFP4	SPIM serial clock pin.
			BPWM0_CH2	I/O	MFP12	BPWM0 channel 2 output/capture input.
		81	PG.13	I/O	MFP0	General purpose digital I/O pin.
			EBI_AD4	I/O	MFP2	EBI address/data bus bit 4.
			SD1_CMD	I/O	MFP3	SD/SDIO1 command/response pin
			SPIM_MISO	I/O	MFP4	SPIM MISO (Master In, Slave Out) pin.
			BPWM0_CH1	I/O	MFP12	BPWM0 channel 1 output/capture input.
		82	PG.14	I/O	MFP0	General purpose digital I/O pin.
			EBI_AD5	I/O	MFP2	EBI address/data bus bit 5.
			SD1_CLK	O	MFP3	SD/SDIO1 clock output pin
			SPIM_MOSI	I/O	MFP4	SPIM MOSI (Master Out, Slave In) pin.
			BPWM0_CH0	I/O	MFP12	BPWM0 channel 0 output/capture input.
		83	PG.15	I/O	MFP0	General purpose digital I/O pin.
			SD1_nCD	I	MFP3	SD/SDIO1 card detect input pin
			CLKO	O	MFP14	Clock Out
			EADC0_ST	I	MFP15	EADC0 external trigger input.
		84	PD.13	I/O	MFP0	General purpose digital I/O pin.
			EBI_AD10	I/O	MFP2	EBI address/data bus bit 10.
			SD0_nCD	I	MFP3	SD/SDIO0 card detect input pin
			SPI0_I2SMCLK	I/O	MFP4	SPI0 I2S master clock output pin
			SPI1_I2SMCLK	I/O	MFP5	SPI1 I2S master clock output pin

64 Pin	64 Pin 2 USB	128 Pin	Pin Name	Type	MFP	Description
			SC2_nCD	I	MFP7	Smart Card 2 card detect pin.
	37	85	PA.12	I/O	MFP0	General purpose digital I/O pin.
			I2S0_BCLK	O	MFP2	I2S0 bit clock output pin.
			UART4_TXD	O	MFP3	UART4 data transmitter output pin.
			I2C1_SCL	I/O	MFP4	I2C1 clock pin.
			SPI2_SS	I/O	MFP5	SPI2 slave select pin.
			SC2_PWR	O	MFP7	Smart Card 2 power pin.
			BPWM1_CH2	I/O	MFP11	BPWM1 channel 2 output/capture input.
			QE1_INDEX	I	MFP12	Quadrature encoder 1 index input
			USB_VBUS	P	MFP14	Power supply from USB host or HUB.
	38	86	PA.13	I/O	MFP0	General purpose digital I/O pin.
			I2S0_MCLK	O	MFP2	I2S0 master clock output pin.
			UART4_RXD	I	MFP3	UART4 data receiver input pin.
			I2C1_SDA	I/O	MFP4	I2C1 data input/output pin.
			SPI2_CLK	I/O	MFP5	SPI2 serial clock pin.
			SC2_RST	O	MFP7	Smart Card 2 reset pin.
			BPWM1_CH3	I/O	MFP11	BPWM1 channel 3 output/capture input.
			QE1_A	I	MFP12	Quadrature encoder 1 phase A input
			USB_D-	A	MFP14	USB differential signal D-.
	39	87	PA.14	I/O	MFP0	General purpose digital I/O pin.
			I2S0_DI	I	MFP2	I2S0 data input pin.
			UART0_TXD	O	MFP3	UART0 data transmitter output pin.
			SPI2_MISO	I/O	MFP5	SPI2 MISO (Master In, Slave Out) pin.
			I2C2_SCL	I/O	MFP6	I2C2 clock pin.
			SC2_DAT	I/O	MFP7	Smart Card 2 data pin.
			BPWM1_CH4	I/O	MFP11	BPWM1 channel 4 output/capture input.
			QE1_B	I	MFP12	Quadrature encoder 1 phase B input
			USB_D+	A	MFP14	USB differential signal D+.
	40	88	PA.15	I/O	MFP0	General purpose digital I/O pin.
			I2S0_DO	O	MFP2	I2S0 data output pin.
			UART0_RXD	I	MFP3	UART0 data receiver input pin.
			SPI2_MOSI	I/O	MFP5	SPI2 MOSI (Master Out, Slave In) pin.
			I2C2_SDA	I/O	MFP6	I2C2 data input/output pin.
			SC2_CLK	O	MFP7	Smart Card 2 clock pin.

64 Pin	64 Pin 2 USB	128 Pin	Pin Name	Type	MFP	Description
			BPWM1_CH5	I/O	MFP11	BPWM1 channel 5 output/capture input.
			EPWM0_SYNC_IN	I	MFP12	EPWM0 counter synchronous trigger input pin.
			USB_OTG_ID	I	MFP14	USB_ identification.
41	41	89	HSUSB_VRES	A	MFP0	HSUSB module reference resistor
42	42	90	HSUSB_VDD33	P	MFP0	Power supply for HSUSB VDD33
43	43	91	HSUSB_VBUS	P	MFP0	HSUSB Power supply from USB host or HUB.
44	44	92	HSUSB_D-	A	MFP0	HSUSB differential signal D-.
45	45	93	HSUSB_VSS	P	MFP0	Ground pin for HSUSB.
46	46	94	HSUSB_D+	A	MFP0	HSUSB differential signal D+.
47	47	95	HSUSB_VDD12_CAP	A	MFP0	HSUSB Internal power regulator output 1.2V decoupling pin. Note: This pin needs to be connected with a 1uF capacitor.
48	48	96	HSUSB_ID	I	MFP0	HSUSB identification.
		97	PE.7	I/O	MFP0	General purpose digital I/O pin.
			SD0_CMD	I/O	MFP3	SD/SDIO0 command/response pin
			SPIM_D2	I/O	MFP4	SPIM data 2 pin for Quad Mode I/O.
			UART5_TXD	O	MFP8	UART5 data transmitter output pin.
			QE1_INDEX	I	MFP11	Quadrature encoder 1 index input
			EPWM0_CH0	I/O	MFP12	EPWM0 channel 0 output/capture input.
			BPWM0_CH5	I/O	MFP13	BPWM0 channel 5 output/capture input.
		98	PE.6	I/O	MFP0	General purpose digital I/O pin.
			SD0_CLK	O	MFP3	SD/SDIO0 clock output pin
			SPIM_D3	I/O	MFP4	SPIM data 3 pin for Quad Mode I/O.
			SPI3_I2SMCLK	I/O	MFP5	SPI3 I2S master clock output pin
			SC0_nCD	I	MFP6	Smart Card 0 card detect pin.
			USCI0_CTL0	I/O	MFP7	USCI0 control 0 pin.
			UART5_RXD	I	MFP8	UART5 data receiver input pin.
			QE1_A	I	MFP11	Quadrature encoder 1 phase A input
			EPWM0_CH1	I/O	MFP12	EPWM0 channel 1 output/capture input.
			BPWM0_CH4	I/O	MFP13	BPWM0 channel 4 output/capture input.
		99	PE.5	I/O	MFP0	General purpose digital I/O pin.
			EBI_nRD	O	MFP2	EBI read enable output pin.
			SD0_DAT3	I/O	MFP3	SD/SDIO0 data line bit 3.
			SPIM_SS	I/O	MFP4	SPIM slave select pin.

64 Pin	64 Pin 2 USB	128 Pin	Pin Name	Type	MFP	Description
			SPI3_SS	I/O	MFP5	SPI3 slave select pin.
			SC0_PWR	O	MFP6	Smart Card 0 power pin.
			USCI0_CTL1	I/O	MFP7	USCI0 control 1 pin.
			QE11_B	I	MFP11	Quadrature encoder 1 phase B input
			EPWM0_CH2	I/O	MFP12	EPWM0 channel 2 output/capture input.
			BPWM0_CH3	I/O	MFP13	BPWM0 channel 3 output/capture input.
		100	PE.4	I/O	MFP0	General purpose digital I/O pin.
			EBI_nWR	O	MFP2	EBI write enable output pin.
			SD0_DAT2	I/O	MFP3	SD/SDIO0 data line bit 2.
			SPIM_CLK	I/O	MFP4	SPIM serial clock pin.
			SPI3_CLK	I/O	MFP5	SPI3 serial clock pin.
			SC0_RST	O	MFP6	Smart Card 0 reset pin.
			USCI0_DAT1	I/O	MFP7	USCI0 data 1 pin.
			QE10_INDEX	I	MFP11	Quadrature encoder 0 index input
			EPWM0_CH3	I/O	MFP12	EPWM0 channel 3 output/capture input.
			BPWM0_CH2	I/O	MFP13	BPWM0 channel 2 output/capture input.
		101	PE.3	I/O	MFP0	General purpose digital I/O pin.
			EBI_MCLK	O	MFP2	EBI external clock output pin.
			SD0_DAT1	I/O	MFP3	SD/SDIO0 data line bit 1.
			SPIM_MISO	I/O	MFP4	SPIM MISO (Master In, Slave Out) pin.
			SPI3_MISO	I/O	MFP5	SPI3 MISO (Master In, Slave Out) pin.
			SC0_DAT	I/O	MFP6	Smart Card 0 data pin.
			USCI0_DAT0	I/O	MFP7	USCI0 data 0 pin.
			QE10_A	I	MFP11	Quadrature encoder 0 phase A input
			EPWM0_CH4	I/O	MFP12	EPWM0 channel 4 output/capture input.
			BPWM0_CH1	I/O	MFP13	BPWM0 channel 1 output/capture input.
		102	PE.2	I/O	MFP0	General purpose digital I/O pin.
			EBI_ALE	O	MFP2	EBI address latch enable output pin.
			SD0_DAT0	I/O	MFP3	SD/SDIO0 data line bit 0.
			SPIM_MOSI	I/O	MFP4	SPIM MOSI (Master Out, Slave In) pin.
			SPI3_MOSI	I/O	MFP5	SPI3 MOSI (Master Out, Slave In) pin.
			SC0_CLK	O	MFP6	Smart Card 0 clock pin.
			USCI0_CLK	I/O	MFP7	USCI0 clock pin.
			QE10_B	I	MFP11	Quadrature encoder 0 phase B input

64 Pin	64 Pin 2 USB	128 Pin	Pin Name	Type	MFP	Description
			EPWM0_CH5	I/O	MFP12	EPWM0 channel 5 output/capture input.
			BPWM0_CH0	I/O	MFP13	BPWM0 channel 0 output/capture input.
		103	V _{SS}	P	MFP0	Ground pin for digital circuit.
		104	V _{DD}	P	MFP0	Power supply for I/O ports and LDO source for internal PLL and digital circuit.
		105	PE.1	I/O	MFP0	General purpose digital I/O pin.
			EBI_AD10	I/O	MFP2	EBI address/data bus bit 10.
			QSPI0_MISO0	I/O	MFP3	Quad SPI0 MISO0 (Master In, Slave Out) pin.
			SC2_DAT	I/O	MFP4	Smart Card 2 data pin.
			I2S0_BCLK	O	MFP5	I2S0 bit clock output pin.
			SPI1_MISO	I/O	MFP6	SPI1 MISO (Master In, Slave Out) pin.
			UART3_TXD	O	MFP7	UART3 data transmitter output pin.
			I2C1_SCL	I/O	MFP8	I2C1 clock pin.
			UART4_nCTS	I	MFP9	UART4 clear to Send input pin.
		106	PE.0	I/O	MFP0	General purpose digital I/O pin.
			EBI_AD11	I/O	MFP2	EBI address/data bus bit 11.
			QSPI0_MOSI0	I/O	MFP3	Quad SPI0 MOSI0 (Master Out, Slave In) pin.
			SC2_CLK	O	MFP4	Smart Card 2 clock pin.
			I2S0_MCLK	O	MFP5	I2S0 master clock output pin.
			SPI1_MOSI	I/O	MFP6	SPI1 MOSI (Master Out, Slave In) pin.
			UART3_RXD	I	MFP7	UART3 data receiver input pin.
			I2C1_SDA	I/O	MFP8	I2C1 data input/output pin.
			UART4_nRTS	O	MFP9	UART4 request to Send output pin.
		107	PH.8	I/O	MFP0	General purpose digital I/O pin.
			EBI_AD12	I/O	MFP2	EBI address/data bus bit 12.
			QSPI0_CLK	I/O	MFP3	Quad SPI0 serial clock pin.
			SC2_PWR	O	MFP4	Smart Card 2 power pin.
			I2S0_DI	I	MFP5	I2S0 data input pin.
			SPI1_CLK	I/O	MFP6	SPI1 serial clock pin.
			UART3_nRTS	O	MFP7	UART3 request to Send output pin.
			I2C1_SMBAL	O	MFP8	I2C1 SMBus SMBALTER pin
			I2C2_SCL	I/O	MFP9	I2C2 clock pin.
			UART1_TXD	O	MFP10	UART1 data transmitter output pin.
		108	PH.9	I/O	MFP0	General purpose digital I/O pin.

64 Pin	64 Pin 2 USB	128 Pin	Pin Name	Type	MFP	Description
			EBI_AD13	I/O	MFP2	EBI address/data bus bit 13.
			QSPI0_SS	I/O	MFP3	Quad SPI0 slave select pin.
			SC2_RST	O	MFP4	Smart Card 2 reset pin.
			I2S0_DO	O	MFP5	I2S0 data output pin.
			SPI1_SS	I/O	MFP6	SPI1 slave select pin.
			UART3_nCTS	I	MFP7	UART3 clear to Send input pin.
			I2C1_SMBSUS	O	MFP8	I2C1 SMBus SMBSUS pin (PMBus CONTROL pin)
			I2C2_SDA	I/O	MFP9	I2C2 data input/output pin.
			UART1_RXD	I	MFP10	UART1 data receiver input pin.
		109	PH.10	I/O	MFP0	General purpose digital I/O pin.
			EBI_AD14	I/O	MFP2	EBI address/data bus bit 14.
			QSPI0_MISO1	I/O	MFP3	Quad SPI0 MISO1 (Master In, Slave Out) pin.
			SC2_nCD	I	MFP4	Smart Card 2 card detect pin.
			I2S0_LRCK	O	MFP5	I2S0 left right channel clock output pin.
			SPI1_I2SMCLK	I/O	MFP6	SPI1 I2S master clock output pin
			UART4_TXD	O	MFP7	UART4 data transmitter output pin.
			UART0_TXD	O	MFP8	UART0 data transmitter output pin.
		110	PH.11	I/O	MFP0	General purpose digital I/O pin.
			EBI_AD15	I/O	MFP2	EBI address/data bus bit 15.
			QSPI0_MOSI1	I/O	MFP3	Quad SPI0 MOSI1 (Master Out, Slave In) pin.
			UART4_RXD	I	MFP7	UART4 data receiver input pin.
			UART0_RXD	I	MFP8	UART0 data receiver input pin.
			EPWM0_CH5	I/O	MFP11	EPWM0 channel 5 output/capture input.
		111	PD.14	I/O	MFP0	General purpose digital I/O pin.
			EBI_nCS0	O	MFP2	EBI chip select 0 output pin.
			SPI3_I2SMCLK	I/O	MFP3	SPI3 I2S master clock output pin
			SC1_nCD	I	MFP4	Smart Card 1 card detect pin.
			EPWM0_CH4	I/O	MFP11	EPWM0 channel 4 output/capture input.
49	49	112	V _{SS}	P	MFP0	Ground pin for digital circuit.
50	50	113	LDO_CAP	A	MFP0	LDO output pin.
51	51	114	V _{DD}	P	MFP0	Power supply for I/O ports and LDO source for internal PLL and digital circuit.
52	52	115	PC.14	I/O	MFP0	General purpose digital I/O pin.
			EBI_AD11	I/O	MFP2	EBI address/data bus bit 11.

64 Pin	64 Pin 2 USB	128 Pin	Pin Name	Type	MFP	Description
			SC1_nCD	I	MFP3	Smart Card 1 card detect pin.
			SPI0_I2SMCLK	I/O	MFP4	SPI0 I2S master clock output pin
			USCI0_CTL0	I/O	MFP5	USCI0 control 0 pin.
			QSPI0_CLK	I/O	MFP6	Quad SPI0 serial clock pin.
			EPWM0_SYNC_IN	I	MFP11	EPWM0 counter synchronous trigger input pin.
			TM1	I/O	MFP13	Timer1 event counter input/toggle output pin.
			USB_VBUS_ST	I	MFP14	USB external VBUS regulator status pin.
			HSUSB_VBUS_ST	I	MFP15	HSUSB external VBUS regulator status pin.
53	53	116	PB.15	I/O	MFP0	General purpose digital I/O pin.
			EADC0_CH15	A	MFP1	EADC0 channel 15 analog input.
			EBI_AD12	I/O	MFP2	EBI address/data bus bit 12.
			SC1_PWR	O	MFP3	Smart Card 1 power pin.
			SPI0_SS	I/O	MFP4	SPI0 slave select pin.
			USCI0_CTL1	I/O	MFP5	USCI0 control 1 pin.
			UART0_nCTS	I	MFP6	UART0 clear to Send input pin.
			UART3_TXD	O	MFP7	UART3 data transmitter output pin.
			I2C2_SMBAL	O	MFP8	I2C2 SMBus SMBALTER pin
			EPWM1_CH0	I/O	MFP11	EPWM1 channel 0 output/capture input.
			TM0_EXT	I/O	MFP13	Timer0 external capture input/toggle output pin.
			USB_VBUS_EN	O	MFP14	USB external VBUS regulator enable pin.
			HSUSB_VBUS_EN	O	MFP15	HSUSB external VBUS regulator enable pin.
54	54	117	PB.14	I/O	MFP0	General purpose digital I/O pin.
			EADC0_CH14	A	MFP1	EADC0 channel 14 analog input.
			EBI_AD13	I/O	MFP2	EBI address/data bus bit 13.
			SC1_RST	O	MFP3	Smart Card 1 reset pin.
			SPI0_CLK	I/O	MFP4	SPI0 serial clock pin.
			USCI0_DAT1	I/O	MFP5	USCI0 data 1 pin.
			UART0_nRTS	O	MFP6	UART0 request to Send output pin.
			UART3_RXD	I	MFP7	UART3 data receiver input pin.
			I2C2_SMBSUS	O	MFP8	I2C2 SMBus SMBSUS pin (PMBus CONTROL pin)
			EPWM1_CH1	I/O	MFP11	EPWM1 channel 1 output/capture input.
			TM1_EXT	I/O	MFP13	Timer1 external capture input/toggle output pin.
			CLKO	O	MFP14	Clock Out
55	55	118	PB.13	I/O	MFP0	General purpose digital I/O pin.

64 Pin	64 Pin 2 USB	128 Pin	Pin Name	Type	MFP	Description
			EADC0_CH13	A	MFP1	EADC0 channel 13 analog input.
			DAC1_OUT	A	MFP1	DAC1 channel analog output.
			ACMP0_P3	A	MFP1	Analog comparator 0 positive input 3 pin.
			ACMP1_P3	A	MFP1	Analog comparator 1 positive input 3 pin.
			EBI_AD14	I/O	MFP2	EBI address/data bus bit 14.
			SC1_DAT	I/O	MFP3	Smart Card 1 data pin.
			SPI0_MISO	I/O	MFP4	SPI0 MISO (Master In, Slave Out) pin.
			USC10_DAT0	I/O	MFP5	USC10 data 0 pin.
			UART0_TXD	O	MFP6	UART0 data transmitter output pin.
			UART3_nRTS	O	MFP7	UART3 request to Send output pin.
			I2C2_SCL	I/O	MFP8	I2C2 clock pin.
			EPWM1_CH2	I/O	MFP11	EPWM1 channel 2 output/capture input.
			TM2_EXT	I/O	MFP13	Timer2 external capture input/toggle output pin.
56	56	119	PB.12	I/O	MFP0	General purpose digital I/O pin.
			EADC0_CH12	A	MFP1	EADC0 channel 12 analog input.
			DAC0_OUT	A	MFP1	DAC0 channel analog output.
			ACMP0_P2	A	MFP1	Analog comparator 0 positive input 2 pin.
			ACMP1_P2	A	MFP1	Analog comparator 1 positive input 2 pin.
			EBI_AD15	I/O	MFP2	EBI address/data bus bit 15.
			SC1_CLK	O	MFP3	Smart Card 1 clock pin.
			SPI0_MOSI	I/O	MFP4	SPI0 MOSI (Master Out, Slave In) pin.
			USC10_CLK	I/O	MFP5	USC10 clock pin.
			UART0_RXD	I	MFP6	UART0 data receiver input pin.
			UART3_nCTS	I	MFP7	UART3 clear to Send input pin.
			I2C2_SDA	I/O	MFP8	I2C2 data input/output pin.
			SD0_nCD	I	MFP9	SD/SDIO0 card detect input pin
			EPWM1_CH3	I/O	MFP11	EPWM1 channel 3 output/capture input.
			TM3_EXT	I/O	MFP13	Timer3 external capture input/toggle output pin.
57	57	120	AV _{DD}	P	MFP0	Power supply for internal analog circuit.
58	58	121	V _{REF}	A	MFP0	ADC reference voltage input. Note: This pin needs to be connected with a 1uF capacitor.
59	59	122	AV _{SS}	P	MFP0	Ground pin for analog circuit.
60	60	123	PB.11	I/O	MFP0	General purpose digital I/O pin.
			EADC0_CH11	A	MFP1	EADC0 channel 11 analog input.

64 Pin	64 Pin 2 USB	128 Pin	Pin Name	Type	MFP	Description
			EBI_ADR16	O	MFP2	EBI address bus bit 16.
			UART0_nCTS	I	MFP5	UART0 clear to Send input pin.
			UART4_TXD	O	MFP6	UART4 data transmitter output pin.
			I2C1_SCL	I/O	MFP7	I2C1 clock pin.
			SPI0_I2SMCLK	I/O	MFP9	SPI0 I2S master clock output pin
			BPWM1_CH0	I/O	MFP10	BPWM1 channel 0 output/capture input.
			SPI3_CLK	I/O	MFP11	SPI3 serial clock pin.
			HSUSB_VBUS_ST	I	MFP14	HSUSB external VBUS regulator status pin.
61	61	124	PB.10	I/O	MFP0	General purpose digital I/O pin.
			EADC0_CH10	A	MFP1	EADC0 channel 10 analog input.
			EBI_ADR17	O	MFP2	EBI address bus bit 17.
			USCI1_CTL0	I/O	MFP4	USCI1 control 0 pin.
			UART0_nRTS	O	MFP5	UART0 request to Send output pin.
			UART4_RXD	I	MFP6	UART4 data receiver input pin.
			I2C1_SDA	I/O	MFP7	I2C1 data input/output pin.
			BPWM1_CH1	I/O	MFP10	BPWM1 channel 1 output/capture input.
			SPI3_SS	I/O	MFP11	SPI3 slave select pin.
			HSUSB_VBUS_EN	O	MFP14	HSUSB external VBUS regulator enable pin.
62	62	125	PB.9	I/O	MFP0	General purpose digital I/O pin.
			EADC0_CH9	A	MFP1	EADC0 channel 9 analog input.
			EBI_ADR18	O	MFP2	EBI address bus bit 18.
			USCI1_CTL1	I/O	MFP4	USCI1 control 1 pin.
			UART0_TXD	O	MFP5	UART0 data transmitter output pin.
			UART1_nCTS	I	MFP6	UART1 clear to Send input pin.
			I2C1_SMBAL	O	MFP7	I2C1 SMBus SMBALTER pin
			BPWM1_CH2	I/O	MFP10	BPWM1 channel 2 output/capture input.
			SPI3_MISO	I/O	MFP11	SPI3 MISO (Master In, Slave Out) pin.
			INT7	I	MFP13	External interrupt 7 input pin.
63	63	126	PB.8	I/O	MFP0	General purpose digital I/O pin.
			EADC0_CH8	A	MFP1	EADC0 channel 8 analog input.
			EBI_ADR19	O	MFP2	EBI address bus bit 19.
			USCI1_CLK	I/O	MFP4	USCI1 clock pin.
			UART0_RXD	I	MFP5	UART0 data receiver input pin.
			UART1_nRTS	O	MFP6	UART1 request to Send output pin.

64 Pin	64 Pin 2 USB	128 Pin	Pin Name	Type	MFP	Description
			I2C1_SMBSUS	O	MFP7	I2C1 SMBus SMBSUS pin (PMBus CONTROL pin)
			BPWM1_CH3	I/O	MFP10	BPWM1 channel 3 output/capture input.
			SPI3_MOSI	I/O	MFP11	SPI3 MOSI (Master Out, Slave In) pin.
			INT6	I	MFP13	External interrupt 6 input pin.
64	64	127	PB.7	I/O	MFP0	General purpose digital I/O pin.
			EADC0_CH7	A	MFP1	EADC0 channel 7 analog input.
			EBI_nWRL	O	MFP2	EBI low byte write enable output pin.
			USCI1_DAT0	I/O	MFP4	USCI1 data 0 pin.
			UART1_TXD	O	MFP6	UART1 data transmitter output pin.
			SD1_CMD	I/O	MFP7	SD/SDIO1 command/response pin
			EBI_nCS0	O	MFP8	EBI chip select 0 output pin.
			BPWM1_CH4	I/O	MFP10	BPWM1 channel 4 output/capture input.
			EPWM1_BRAKE0	I	MFP11	EPWM1 Brake 0 input pin.
			EPWM1_CH4	I/O	MFP12	EPWM1 channel 4 output/capture input.
			INT5	I	MFP13	External interrupt 5 input pin.
			USB_VBUS_ST	I	MFP14	USB external VBUS regulator status pin.
			ACMP0_O	O	MFP15	Analog comparator 0 output pin.
1	1	128	PB.6	I/O	MFP0	General purpose digital I/O pin.
			EADC0_CH6	A	MFP1	EADC0 channel 6 analog input.
			EBI_nWRH	O	MFP2	EBI high byte write enable output pin
			USCI1_DAT1	I/O	MFP4	USCI1 data 1 pin.
			UART1_RXD	I	MFP6	UART1 data receiver input pin.
			SD1_CLK	O	MFP7	SD/SDIO1 clock output pin
			EBI_nCS1	O	MFP8	EBI chip select 1 output pin.
			BPWM1_CH5	I/O	MFP10	BPWM1 channel 5 output/capture input.
			EPWM1_BRAKE1	I	MFP11	EPWM1 Brake 1 input pin.
			EPWM1_CH5	I/O	MFP12	EPWM1 channel 5 output/capture input.
			INT4	I	MFP13	External interrupt 4 input pin.
			USB_VBUS_EN	O	MFP14	USB external VBUS regulator enable pin.
			ACMP1_O	O	MFP15	Analog comparator 1 output pin.

4.2.5 M485 Series Pin Description

32 Pin	48 Pin	64 Pin	128 Pin	Pin Name	Type	MFP	Description
1	1	2	1	PB.5	I/O	MFP0	General purpose digital I/O pin.
				EADC0_CH5	A	MFP1	EADC0 channel 5 analog input.
				ACMP1_N	A	MFP1	Analog comparator 1 negative input pin.
				EBI_ADR0	O	MFP2	EBI address bus bit 0.
				SD0_DAT3	I/O	MFP3	SD/SDIO0 data line bit 3.
				SPI1_MISO	I/O	MFP5	SPI1 MISO (Master In, Slave Out) pin.
				I2C0_SCL	I/O	MFP6	I2C0 clock pin.
				UART5_TXD	O	MFP7	UART5 data transmitter output pin.
				USCI1_CTL0	I/O	MFP8	USCI1 control 0 pin.
				SC0_CLK	O	MFP9	Smart Card 0 clock pin.
				I2S0_BCLK	O	MFP10	I2S0 bit clock output pin.
				EPWM0_CH0	I/O	MFP11	EPWM0 channel 0 output/capture input.
				TM0	I/O	MFP14	Timer0 event counter input/toggle output pin.
INT0	I	MFP15	External interrupt 0 input pin.				
2	2	3	2	PB.4	I/O	MFP0	General purpose digital I/O pin.
				EADC0_CH4	A	MFP1	EADC0 channel 4 analog input.
				ACMP1_P1	A	MFP1	Analog comparator 1 positive input 1 pin.
				EBI_ADR1	O	MFP2	EBI address bus bit 1.
				SD0_DAT2	I/O	MFP3	SD/SDIO0 data line bit 2.
				SPI1_MOSI	I/O	MFP5	SPI1 MOSI (Master Out, Slave In) pin.
				I2C0_SDA	I/O	MFP6	I2C0 data input/output pin.
				UART5_RXD	I	MFP7	UART5 data receiver input pin.
				USCI1_CTL1	I/O	MFP8	USCI1 control 1 pin.
				SC0_DAT	I/O	MFP9	Smart Card 0 data pin.
				I2S0_MCLK	O	MFP10	I2S0 master clock output pin.
				EPWM0_CH1	I/O	MFP11	EPWM0 channel 1 output/capture input.
				TM1	I/O	MFP14	Timer1 event counter input/toggle output pin.
INT1	I	MFP15	External interrupt 1 input pin.				
3	3	4	3	PB.3	I/O	MFP0	General purpose digital I/O pin.
				EADC0_CH3	A	MFP1	EADC0 channel 3 analog input.
				ACMP0_N	A	MFP1	Analog comparator 0 negative input pin.
				EBI_ADR2	O	MFP2	EBI address bus bit 2.
				SD0_DAT1	I/O	MFP3	SD/SDIO0 data line bit 1.

32 Pin	48 Pin	64 Pin	128 Pin	Pin Name	Type	MFP	Description
				SPI1_CLK	I/O	MFP5	SPI1 serial clock pin.
				UART1_TXD	O	MFP6	UART1 data transmitter output pin.
				UART5_nRTS	O	MFP7	UART5 request to Send output pin.
				USCI1_DAT1	I/O	MFP8	USCI1 data 1 pin.
				SC0_RST	O	MFP9	Smart Card 0 reset pin.
				I2S0_DI	I	MFP10	I2S0 data input pin.
				EPWM0_CH2	I/O	MFP11	EPWM0 channel 2 output/capture input.
				TM2	I/O	MFP14	Timer2 event counter input/toggle output pin.
				INT2	I	MFP15	External interrupt 2 input pin.
4	4	5	4	PB.2	I/O	MFP0	General purpose digital I/O pin.
				EADC0_CH2	A	MFP1	EADC0 channel 2 analog input.
				ACMP0_P1	A	MFP1	Analog comparator 0 positive input 1 pin.
				OPA0_O	A	MFP1	Operational amplifier 0 output pin.
				EBI_ADR3	O	MFP2	EBI address bus bit 3.
				SD0_DAT0	I/O	MFP3	SD/SDIO0 data line bit 0.
				SPI1_SS	I/O	MFP5	SPI1 slave select pin.
				UART1_RXD	I	MFP6	UART1 data receiver input pin.
				UART5_nCTS	I	MFP7	UART5 clear to Send input pin.
				USCI1_DAT0	I/O	MFP8	USCI1 data 0 pin.
				SC0_PWR	O	MFP9	Smart Card 0 power pin.
				I2S0_DO	O	MFP10	I2S0 data output pin.
				EPWM0_CH3	I/O	MFP11	EPWM0 channel 3 output/capture input.
				TM3	I/O	MFP14	Timer3 event counter input/toggle output pin.
				INT3	I	MFP15	External interrupt 3 input pin.
			5	PC.12	I/O	MFP0	General purpose digital I/O pin.
				EBI_ADR4	O	MFP2	EBI address bus bit 4.
				UART0_TXD	O	MFP3	UART0 data transmitter output pin.
				I2C0_SCL	I/O	MFP4	I2C0 clock pin.
				SPI3_MISO	I/O	MFP6	SPI3 MISO (Master In, Slave Out) pin.
				SC0_nCD	I	MFP9	Smart Card 0 card detect pin.
				ECAP1_IC2	I	MFP11	Enhanced capture unit 1 input 2 pin.
				EPWM1_CH0	I/O	MFP12	EPWM1 channel 0 output/capture input.
				ACMP0_O	O	MFP14	Analog comparator 0 output pin.
			6	PC.11	I/O	MFP0	General purpose digital I/O pin.

32 Pin	48 Pin	64 Pin	128 Pin	Pin Name	Type	MFP	Description
				EBI_ADR5	O	MFP2	EBI address bus bit 5.
				UART0_RXD	I	MFP3	UART0 data receiver input pin.
				I2C0_SDA	I/O	MFP4	I2C0 data input/output pin.
				SPI3_MOSI	I/O	MFP6	SPI3 MOSI (Master Out, Slave In) pin.
				ECAP1_IC1	I	MFP11	Enhanced capture unit 1 input 1 pin.
				EPWM1_CH1	I/O	MFP12	EPWM1 channel 1 output/capture input.
				ACMP1_O	O	MFP14	Analog comparator 1 output pin.
			7	PC.10	I/O	MFP0	General purpose digital I/O pin.
				EBI_ADR6	O	MFP2	EBI address bus bit 6.
				SPI3_CLK	I/O	MFP6	SPI3 serial clock pin.
				UART3_TXD	O	MFP7	UART3 data transmitter output pin.
				CAN1_TXD	O	MFP9	CAN1 bus transmitter output.
				ECAP1_IC0	I	MFP11	Enhanced capture unit 1 input 0 pin.
				EPWM1_CH2	I/O	MFP12	EPWM1 channel 2 output/capture input.
			8	PC.9	I/O	MFP0	General purpose digital I/O pin.
				EBI_ADR7	O	MFP2	EBI address bus bit 7.
				SPI3_SS	I/O	MFP6	SPI3 slave select pin.
				UART3_RXD	I	MFP7	UART3 data receiver input pin.
				CAN1_RXD	I	MFP9	CAN1 bus receiver input.
				EPWM1_CH3	I/O	MFP12	EPWM1 channel 3 output/capture input.
5	5	6	9	PB.1	I/O	MFP0	General purpose digital I/O pin.
				EADC0_CH1	A	MFP1	EADC0 channel 1 analog input.
				OPA0_N	A	MFP1	Operational amplifier 0 negative input pin.
				EBI_ADR8	O	MFP2	EBI address bus bit 8.
				SD0_CLK	O	MFP3	SD/SDIO0 clock output pin
				SPI1_I2SMCLK	I/O	MFP5	SPI1 I2S master clock output pin
				SPI3_I2SMCLK	I/O	MFP6	SPI3 I2S master clock output pin
				UART2_TXD	O	MFP7	UART2 data transmitter output pin.
				USC11_CLK	I/O	MFP8	USC11 clock pin.
				I2C1_SCL	I/O	MFP9	I2C1 clock pin.
				I2S0_LRCK	O	MFP10	I2S0 left right channel clock output pin.
				EPWM0_CH4	I/O	MFP11	EPWM0 channel 4 output/capture input.
				EPWM1_CH4	I/O	MFP12	EPWM1 channel 4 output/capture input.
				EPWM0_BRAKE0	I	MFP13	EPWM0 Brake 0 input pin.

32 Pin	48 Pin	64 Pin	128 Pin	Pin Name	Type	MFP	Description
6	6	7	10	PB.0	I/O	MFP0	General purpose digital I/O pin.
				EADC0_CH0	A	MFP1	EADC0 channel 0 analog input.
				OPA0_P	A	MFP1	Operational amplifier 0 positive input pin.
				EBI_ADR9	O	MFP2	EBI address bus bit 9.
				SD0_CMD	I/O	MFP3	SD/SDIO0 command/response pin
				UART2_RXD	I	MFP7	UART2 data receiver input pin.
				SPI0_I2SMCLK	I/O	MFP8	SPI0 I2S master clock output pin
				I2C1_SDA	I/O	MFP9	I2C1 data input/output pin.
				EPWM0_CH5	I/O	MFP11	EPWM0 channel 5 output/capture input.
				EPWM1_CH5	I/O	MFP12	EPWM1 channel 5 output/capture input.
				EPWM0_BRAKE1	I	MFP13	EPWM0 Brake 1 input pin.
			11	VSS	P	MFP0	Ground pin for digital circuit.
			12	V _{DD}	P	MFP0	Power supply for I/O ports and LDO source for internal PLL and digital circuit.
7	8	8	13	PA.11	I/O	MFP0	General purpose digital I/O pin.
				ACMP0_P0	A	MFP1	Analog comparator 0 positive input 0 pin.
				EBI_nRD	O	MFP2	EBI read enable output pin.
				SC2_PWR	O	MFP3	Smart Card 2 power pin.
				SPI2_SS	I/O	MFP4	SPI2 slave select pin.
				SD1_DAT3	I/O	MFP5	SD/SDIO1 data line bit 3.
				USCI0_CLK	I/O	MFP6	USCI0 clock pin.
				I2C2_SCL	I/O	MFP7	I2C2 clock pin.
				BPWM0_CH0	I/O	MFP9	BPWM0 channel 0 output/capture input.
				EPWM0_SYNC_OUT	O	MFP10	EPWM0 counter synchronous trigger output pin.
				TM0_EXT	I/O	MFP13	Timer0 external capture input/toggle output pin.
				DAC1_ST	I	MFP14	DAC1 external trigger input.
8	9	9	14	PA.10	I/O	MFP0	General purpose digital I/O pin.
				ACMP1_P0	A	MFP1	Analog comparator 1 positive input 0 pin.
				OPA1_O	A	MFP1	Operational amplifier 1 output pin.
				EBI_nWR	O	MFP2	EBI write enable output pin.
				SC2_RST	O	MFP3	Smart Card 2 reset pin.
				SPI2_CLK	I/O	MFP4	SPI2 serial clock pin.
				SD1_DAT2	I/O	MFP5	SD/SDIO1 data line bit 2.
				USCI0_DAT0	I/O	MFP6	USCI0 data 0 pin.

32 Pin	48 Pin	64 Pin	128 Pin	Pin Name	Type	MFP	Description
				I2C2_SDA	I/O	MFP7	I2C2 data input/output pin.
				BPWM0_CH1	I/O	MFP9	BPWM0 channel 1 output/capture input.
				QE11_INDEX	I	MFP10	Quadrature encoder 1 index input
				ECAP0_IC0	I	MFP11	Enhanced capture unit 0 input 0 pin.
				TM1_EXT	I/O	MFP13	Timer1 external capture input/toggle output pin.
				DAC0_ST	I	MFP14	DAC0 external trigger input.
	9	10	15	PA.9	I/O	MFP0	General purpose digital I/O pin.
				OPA1_N	A	MFP1	Operational amplifier 1 negative input pin.
				EBI_MCLK	O	MFP2	EBI external clock output pin.
				SC2_DAT	I/O	MFP3	Smart Card 2 data pin.
				SPI2_MISO	I/O	MFP4	SPI2 MISO (Master In, Slave Out) pin.
				SD1_DAT1	I/O	MFP5	SD/SDIO1 data line bit 1.
				USCI0_DAT1	I/O	MFP6	USCI0 data 1 pin.
				UART1_TXD	O	MFP7	UART1 data transmitter output pin.
				BPWM0_CH2	I/O	MFP9	BPWM0 channel 2 output/capture input.
				QE11_A	I	MFP10	Quadrature encoder 1 phase A input
				ECAP0_IC1	I	MFP11	Enhanced capture unit 0 input 1 pin.
				TM2_EXT	I/O	MFP13	Timer2 external capture input/toggle output pin.
	10	11	16	PA.8	I/O	MFP0	General purpose digital I/O pin.
				OPA1_P	A	MFP1	Operational amplifier 1 positive input pin.
				EBI_ALE	O	MFP2	EBI address latch enable output pin.
				SC2_CLK	O	MFP3	Smart Card 2 clock pin.
				SPI2_MOSI	I/O	MFP4	SPI2 MOSI (Master Out, Slave In) pin.
				SD1_DAT0	I/O	MFP5	SD/SDIO1 data line bit 0.
				USCI0_CTL1	I/O	MFP6	USCI0 control 1 pin.
				UART1_RXD	I	MFP7	UART1 data receiver input pin.
				BPWM0_CH3	I/O	MFP9	BPWM0 channel 3 output/capture input.
				QE11_B	I	MFP10	Quadrature encoder 1 phase B input
				ECAP0_IC2	I	MFP11	Enhanced capture unit 0 input 2 pin.
				TM3_EXT	I/O	MFP13	Timer3 external capture input/toggle output pin.
				INT4	I	MFP15	External interrupt 4 input pin.
			17	PC.13	I/O	MFP0	General purpose digital I/O pin.
				EBI_ADR10	O	MFP2	EBI address bus bit 10.
				SC2_nCD	I	MFP3	Smart Card 2 card detect pin.

32 Pin	48 Pin	64 Pin	128 Pin	Pin Name	Type	MFP	Description
				SPI2_I2SMCLK	I/O	MFP4	SPI2 I2S master clock output pin
				CAN1_TXD	O	MFP5	CAN1 bus transmitter output.
				USCI0_CTL0	I/O	MFP6	USCI0 control 0 pin.
				UART2_TXD	O	MFP7	UART2 data transmitter output pin.
				BPWM0_CH4	I/O	MFP9	BPWM0 channel 4 output/capture input.
				CLKO	O	MFP13	Clock Out
				EADC0_ST	I	MFP14	EADC0 external trigger input.
			18	PD.12	I/O	MFP0	General purpose digital I/O pin.
				OPA2_O	A	MFP1	Operational amplifier 2 output pin.
				EBI_nCS0	O	MFP2	EBI chip select 0 output pin.
				CAN1_RXD	I	MFP5	CAN1 bus receiver input.
				UART2_RXD	I	MFP7	UART2 data receiver input pin.
				BPWM0_CH5	I/O	MFP9	BPWM0 channel 5 output/capture input.
				QEI0_INDEX	I	MFP10	Quadrature encoder 0 index input
				CLKO	O	MFP13	Clock Out
				EADC0_ST	I	MFP14	EADC0 external trigger input.
				INT5	I	MFP15	External interrupt 5 input pin.
			19	PD.11	I/O	MFP0	General purpose digital I/O pin.
				OPA2_N	A	MFP1	Operational amplifier 2 negative input pin.
				EBI_nCS1	O	MFP2	EBI chip select 1 output pin.
				UART1_TXD	O	MFP3	UART1 data transmitter output pin.
				CAN0_TXD	O	MFP4	CAN0 bus transmitter output.
				QEI0_A	I	MFP10	Quadrature encoder 0 phase A input
				INT6	I	MFP15	External interrupt 6 input pin.
			20	PD.10	I/O	MFP0	General purpose digital I/O pin.
				OPA2_P	A	MFP1	Operational amplifier 2 positive input pin.
				EBI_nCS2	O	MFP2	EBI chip select 2 output pin.
				UART1_RXD	I	MFP3	UART1 data receiver input pin.
				CAN0_RXD	I	MFP4	CAN0 bus receiver input.
				QEI0_B	I	MFP10	Quadrature encoder 0 phase B input
				INT7	I	MFP15	External interrupt 7 input pin.
			21	PG.2	I/O	MFP0	General purpose digital I/O pin.
				EBI_ADR11	O	MFP2	EBI address bus bit 11.
				SPI2_SS	I/O	MFP3	SPI2 slave select pin.

32 Pin	48 Pin	64 Pin	128 Pin	Pin Name	Type	MFP	Description
				I2C0_SMBAL	O	MFP4	I2C0 SMBus SMBALTER pin
				I2C1_SCL	I/O	MFP5	I2C1 clock pin.
				TM0	I/O	MFP13	Timer0 event counter input/toggle output pin.
			22	PG.3	I/O	MFP0	General purpose digital I/O pin.
				EBI_ADR12	O	MFP2	EBI address bus bit 12.
				SPI2_CLK	I/O	MFP3	SPI2 serial clock pin.
				I2C0_SMBUS	O	MFP4	I2C0 SMBus SMBUS pin (PMBus CONTROL pin)
				I2C1_SDA	I/O	MFP5	I2C1 data input/output pin.
				TM1	I/O	MFP13	Timer1 event counter input/toggle output pin.
			23	PG.4	I/O	MFP0	General purpose digital I/O pin.
				EBI_ADR13	O	MFP2	EBI address bus bit 13.
				SPI2_MISO	I/O	MFP3	SPI2 MISO (Master In, Slave Out) pin.
				TM2	I/O	MFP13	Timer2 event counter input/toggle output pin.
			24	PF.11	I/O	MFP0	General purpose digital I/O pin.
				EBI_ADR14	O	MFP2	EBI address bus bit 14.
				SPI2_MOSI	I/O	MFP3	SPI2 MOSI (Master Out, Slave In) pin.
				TAMPER5	I/O	MFP10	TAMPER detector loop pin 5.
				TM3	I/O	MFP13	Timer3 event counter input/toggle output pin.
			25	PF.10	I/O	MFP0	General purpose digital I/O pin.
				EBI_ADR15	O	MFP2	EBI address bus bit 15.
				SC0_nCD	I	MFP3	Smart Card 0 card detect pin.
				I2S0_BCLK	O	MFP4	I2S0 bit clock output pin.
				SPI0_I2SMCLK	I/O	MFP5	SPI0 I2S master clock output pin
				TAMPER4	I/O	MFP10	TAMPER detector loop pin 4.
			26	PF.9	I/O	MFP0	General purpose digital I/O pin.
				EBI_ADR16	O	MFP2	EBI address bus bit 16.
				SC0_PWR	O	MFP3	Smart Card 0 power pin.
				I2S0_MCLK	O	MFP4	I2S0 master clock output pin.
				SPI0_SS	I/O	MFP5	SPI0 slave select pin.
				TAMPER3	I/O	MFP10	TAMPER detector loop pin 3.
			27	PF.8	I/O	MFP0	General purpose digital I/O pin.
				EBI_ADR17	O	MFP2	EBI address bus bit 17.
				SC0_RST	O	MFP3	Smart Card 0 reset pin.
				I2S0_DI	I	MFP4	I2S0 data input pin.

32 Pin	48 Pin	64 Pin	128 Pin	Pin Name	Type	MFP	Description
				SPI0_CLK	I/O	MFP5	SPI0 serial clock pin.
				TAMPER2	I/O	MFP10	TAMPER detector loop pin 2.
			28	PF.7	I/O	MFP0	General purpose digital I/O pin.
				EBI_ADR18	O	MFP2	EBI address bus bit 18.
				SC0_DAT	I/O	MFP3	Smart Card 0 data pin.
				I2S0_DO	O	MFP4	I2S0 data output pin.
				SPI0_MISO	I/O	MFP5	SPI0 MISO (Master In, Slave Out) pin.
				UART4_TXD	O	MFP6	UART4 data transmitter output pin.
				TAMPER1	I/O	MFP10	TAMPER detector loop pin 1.
		12	29	PF.6	I/O	MFP0	General purpose digital I/O pin.
				EBI_ADR19	O	MFP2	EBI address bus bit 19.
				SC0_CLK	O	MFP3	Smart Card 0 clock pin.
				I2S0_LRCK	O	MFP4	I2S0 left right channel clock output pin.
				SPI0_MOSI	I/O	MFP5	SPI0 MOSI (Master Out, Slave In) pin.
				UART4_RXD	I	MFP6	UART4 data receiver input pin.
				EBI_nCS0	O	MFP7	EBI chip select 0 output pin.
				TAMPER0	I/O	MFP10	TAMPER detector loop pin 0.
		13	30	V _{DD}	P	MFP0	Power supply for I/O ports and LDO source for internal PLL and digital circuit.
7	11	14	31	PF.5	I/O	MFP0	General purpose digital I/O pin.
				UART2_RXD	I	MFP2	UART2 data receiver input pin.
				UART2_nCTS	I	MFP4	UART2 clear to Send input pin.
				BPWM0_CH4	I/O	MFP8	BPWM0 channel 4 output/capture input.
				EPWM0_SYNC_OUT	O	MFP9	EPWM0 counter synchronous trigger output pin.
				X32_IN	I	MFP10	External 32.768 kHz crystal input pin.
				EADC0_ST	I	MFP11	EADC0 external trigger input.
8	12	15	32	PF.4	I/O	MFP0	General purpose digital I/O pin.
				UART2_TXD	O	MFP2	UART2 data transmitter output pin.
				UART2_nRTS	O	MFP4	UART2 request to Send output pin.
				BPWM0_CH5	I/O	MFP8	BPWM0 channel 5 output/capture input.
				X32_OUT	O	MFP10	External 32.768 kHz crystal output pin.
			33	PH.4	I/O	MFP0	General purpose digital I/O pin.
				EBI_ADR3	O	MFP2	EBI address bus bit 3.
				SPI1_MISO	I/O	MFP3	SPI1 MISO (Master In, Slave Out) pin.

32 Pin	48 Pin	64 Pin	128 Pin	Pin Name	Type	MFP	Description
			34	PH.5	I/O	MFP0	General purpose digital I/O pin.
				EBI_ADR2	O	MFP2	EBI address bus bit 2.
				SPI1_MOSI	I/O	MFP3	SPI1 MOSI (Master Out, Slave In) pin.
			35	PH.6	I/O	MFP0	General purpose digital I/O pin.
				EBI_ADR1	O	MFP2	EBI address bus bit 1.
				SPI1_CLK	I/O	MFP3	SPI1 serial clock pin.
			36	PH.7	I/O	MFP0	General purpose digital I/O pin.
				EBI_ADR0	O	MFP2	EBI address bus bit 0.
				SPI1_SS	I/O	MFP3	SPI1 slave select pin.
9	13	16	37	PF.3	I/O	MFP0	General purpose digital I/O pin.
				EBI_nCS0	O	MFP2	EBI chip select 0 output pin.
				UART0_TXD	O	MFP3	UART0 data transmitter output pin.
				I2C0_SCL	I/O	MFP4	I2C0 clock pin.
				XT1_IN	I	MFP10	External 4~24 MHz (high speed) crystal input pin.
				BPWM1_CH0	I/O	MFP11	BPWM1 channel 0 output/capture input.
10	14	17	38	PF.2	I/O	MFP0	General purpose digital I/O pin.
				EBI_nCS1	O	MFP2	EBI chip select 1 output pin.
				UART0_RXD	I	MFP3	UART0 data receiver input pin.
				I2C0_SDA	I/O	MFP4	I2C0 data input/output pin.
				QSPI0_CLK	I/O	MFP5	Quad SPI0 serial clock pin.
				XT1_OUT	O	MFP10	External 4~24 MHz (high speed) crystal output pin.
				BPWM1_CH1	I/O	MFP11	BPWM1 channel 1 output/capture input.
			39	VSS	P	MFP0	Ground pin for digital circuit.
			40	VDD	P	MFP0	Power supply for I/O ports and LDO source for internal PLL and digital circuit.
			41	PE.8	I/O	MFP0	General purpose digital I/O pin.
				EBI_ADR10	O	MFP2	EBI address bus bit 10.
				I2S0_BCLK	O	MFP4	I2S0 bit clock output pin.
				SPI2_CLK	I/O	MFP5	SPI2 serial clock pin.
				USCI1_CTL1	I/O	MFP6	USCI1 control 1 pin.
				UART2_TXD	O	MFP7	UART2 data transmitter output pin.
				EPWM0_CH0	I/O	MFP10	EPWM0 channel 0 output/capture input.
				EPWM0_BRAKE0	I	MFP11	EPWM0 Brake 0 input pin.
				ECAP0_IC0	I	MFP12	Enhanced capture unit 0 input 0 pin.

32 Pin	48 Pin	64 Pin	128 Pin	Pin Name	Type	MFP	Description
				TRACE_CLK	O	MFP14	ETM Trace Clock output pin
			42	PE.9	I/O	MFP0	General purpose digital I/O pin.
				EBI_ADR11	O	MFP2	EBI address bus bit 11.
				I2S0_MCLK	O	MFP4	I2S0 master clock output pin.
				SPI2_MISO	I/O	MFP5	SPI2 MISO (Master In, Slave Out) pin.
				USCI1_CTL0	I/O	MFP6	USCI1 control 0 pin.
				UART2_RXD	I	MFP7	UART2 data receiver input pin.
				EPWM0_CH1	I/O	MFP10	EPWM0 channel 1 output/capture input.
				EPWM0_BRAKE1	I	MFP11	EPWM0 Brake 1 input pin.
				ECAP0_IC1	I	MFP12	Enhanced capture unit 0 input 1 pin.
			TRACE_DATA0	O	MFP14	ETM Trace Data 0 output pin	
			43	PE.10	I/O	MFP0	General purpose digital I/O pin.
				EBI_ADR12	O	MFP2	EBI address bus bit 12.
				I2S0_DI	I	MFP4	I2S0 data input pin.
				SPI2_MOSI	I/O	MFP5	SPI2 MOSI (Master Out, Slave In) pin.
				USCI1_DAT0	I/O	MFP6	USCI1 data 0 pin.
				UART3_TXD	O	MFP7	UART3 data transmitter output pin.
				EPWM0_CH2	I/O	MFP10	EPWM0 channel 2 output/capture input.
				EPWM1_BRAKE0	I	MFP11	EPWM1 Brake 0 input pin.
				ECAP0_IC2	I	MFP12	Enhanced capture unit 0 input 2 pin.
			TRACE_DATA1	O	MFP14	ETM Trace Data 1 output pin	
			44	PE.11	I/O	MFP0	General purpose digital I/O pin.
				EBI_ADR13	O	MFP2	EBI address bus bit 13.
				I2S0_DO	O	MFP4	I2S0 data output pin.
				SPI2_SS	I/O	MFP5	SPI2 slave select pin.
				USCI1_DAT1	I/O	MFP6	USCI1 data 1 pin.
				UART3_RXD	I	MFP7	UART3 data receiver input pin.
				UART1_nCTS	I	MFP8	UART1 clear to Send input pin.
				EPWM0_CH3	I/O	MFP10	EPWM0 channel 3 output/capture input.
				EPWM1_BRAKE1	I	MFP11	EPWM1 Brake 1 input pin.
			ECAP1_IC2	I	MFP13	Enhanced capture unit 1 input 2 pin.	
			TRACE_DATA2	O	MFP14	ETM Trace Data 2 output pin	
			45	PE.12	I/O	MFP0	General purpose digital I/O pin.
				EBI_ADR14	O	MFP2	EBI address bus bit 14.

32 Pin	48 Pin	64 Pin	128 Pin	Pin Name	Type	MFP	Description
				I2S0_LRCK	O	MFP4	I2S0 left right channel clock output pin.
				SPI2_I2SMCLK	I/O	MFP5	SPI2 I2S master clock output pin
				USCI1_CLK	I/O	MFP6	USCI1 clock pin.
				UART1_nRTS	O	MFP8	UART1 request to Send output pin.
				EPWM0_CH4	I/O	MFP10	EPWM0 channel 4 output/capture input.
				ECAP1_IC1	I	MFP13	Enhanced capture unit 1 input 1 pin.
				TRACE_DATA3	O	MFP14	ETM Trace Data 3 output pin
			46	PE.13	I/O	MFP0	General purpose digital I/O pin.
				EBI_ADR15	O	MFP2	EBI address bus bit 15.
				I2C0_SCL	I/O	MFP4	I2C0 clock pin.
				UART4_nRTS	O	MFP5	UART4 request to Send output pin.
				UART1_TXD	O	MFP8	UART1 data transmitter output pin.
				EPWM0_CH5	I/O	MFP10	EPWM0 channel 5 output/capture input.
				EPWM1_CH0	I/O	MFP11	EPWM1 channel 0 output/capture input.
				BPWM1_CH5	I/O	MFP12	BPWM1 channel 5 output/capture input.
				ECAP1_IC0	I	MFP13	Enhanced capture unit 1 input 0 pin.
			47	PC.8	I/O	MFP0	General purpose digital I/O pin.
				EBI_ADR16	O	MFP2	EBI address bus bit 16.
				I2C0_SDA	I/O	MFP4	I2C0 data input/output pin.
				UART4_nCTS	I	MFP5	UART4 clear to Send input pin.
				UART1_RXD	I	MFP8	UART1 data receiver input pin.
				EPWM1_CH1	I/O	MFP11	EPWM1 channel 1 output/capture input.
				BPWM1_CH4	I/O	MFP12	BPWM1 channel 4 output/capture input.
		18	48	PC.7	I/O	MFP0	General purpose digital I/O pin.
				EBI_AD9	I/O	MFP2	EBI address/data bus bit 9.
				SPI1_MISO	I/O	MFP4	SPI1 MISO (Master In, Slave Out) pin.
				UART4_TXD	O	MFP5	UART4 data transmitter output pin.
				SC2_PWR	O	MFP6	Smart Card 2 power pin.
				UART0_nCTS	I	MFP7	UART0 clear to Send input pin.
				I2C1_SMBAL	O	MFP8	I2C1 SMBus SMBALTER pin
				EPWM1_CH2	I/O	MFP11	EPWM1 channel 2 output/capture input.
				BPWM1_CH0	I/O	MFP12	BPWM1 channel 0 output/capture input.
				TM0	I/O	MFP14	Timer0 event counter input/toggle output pin.
				INT3	I	MFP15	External interrupt 3 input pin.

32 Pin	48 Pin	64 Pin	128 Pin	Pin Name	Type	MFP	Description
		19	49	PC.6	I/O	MFP0	General purpose digital I/O pin.
				EBI_AD8	I/O	MFP2	EBI address/data bus bit 8.
				SPI1_MOSI	I/O	MFP4	SPI1 MOSI (Master Out, Slave In) pin.
				UART4_RXD	I	MFP5	UART4 data receiver input pin.
				SC2_RST	O	MFP6	Smart Card 2 reset pin.
				UART0_nRTS	O	MFP7	UART0 request to Send output pin.
				I2C1_SMBSUS	O	MFP8	I2C1 SMBus SMBSUS pin (PMBus CONTROL pin)
				EPWM1_CH3	I/O	MFP11	EPWM1 channel 3 output/capture input.
				BPWM1_CH1	I/O	MFP12	BPWM1 channel 1 output/capture input.
				TM1	I/O	MFP14	Timer1 event counter input/toggle output pin.
				INT2	I	MFP15	External interrupt 2 input pin.
	15	20	50	PA.7	I/O	MFP0	General purpose digital I/O pin.
				EBI_AD7	I/O	MFP2	EBI address/data bus bit 7.
				SPI1_CLK	I/O	MFP4	SPI1 serial clock pin.
				SC2_DAT	I/O	MFP6	Smart Card 2 data pin.
				UART0_TXD	O	MFP7	UART0 data transmitter output pin.
				I2C1_SCL	I/O	MFP8	I2C1 clock pin.
				EPWM1_CH4	I/O	MFP11	EPWM1 channel 4 output/capture input.
				BPWM1_CH2	I/O	MFP12	BPWM1 channel 2 output/capture input.
				ACMP0_WLAT	I	MFP13	Analog comparator 0 window latch input pin
				TM2	I/O	MFP14	Timer2 event counter input/toggle output pin.
				INT1	I	MFP15	External interrupt 1 input pin.
	16	21	51	PA.6	I/O	MFP0	General purpose digital I/O pin.
				EBI_AD6	I/O	MFP2	EBI address/data bus bit 6.
				SPI1_SS	I/O	MFP4	SPI1 slave select pin.
				SD1_nCD	I	MFP5	SD/SDIO1 card detect input pin
				SC2_CLK	O	MFP6	Smart Card 2 clock pin.
				UART0_RXD	I	MFP7	UART0 data receiver input pin.
				I2C1_SDA	I/O	MFP8	I2C1 data input/output pin.
				EPWM1_CH5	I/O	MFP11	EPWM1 channel 5 output/capture input.
				BPWM1_CH3	I/O	MFP12	BPWM1 channel 3 output/capture input.
				ACMP1_WLAT	I	MFP13	Analog comparator 1 window latch input pin
				TM3	I/O	MFP14	Timer3 event counter input/toggle output pin.
				INT0	I	MFP15	External interrupt 0 input pin.

32 Pin	48 Pin	64 Pin	128 Pin	Pin Name	Type	MFP	Description
		22	52	VSS	P	MFP0	Ground pin for digital circuit.
		23	53	VDD	P	MFP0	Power supply for I/O ports and LDO source for internal PLL and digital circuit.
		24	54	LDO_CAP	A	MFP0	LDO output pin.
17	25	55	PA.5	I/O	MFP0	General purpose digital I/O pin.	
			SPIM_D2	I/O	MFP2	SPIM data 2 pin for Quad Mode I/O.	
			QSPIO_MISO1	I/O	MFP3	Quad SPI0 MISO1 (Master In, Slave Out) pin.	
			SPI1_I2SMCLK	I/O	MFP4	SPI1 I2S master clock output pin	
			SD1_CMD	I/O	MFP5	SD/SDIO1 command/response pin	
			SC2_nCD	I	MFP6	Smart Card 2 card detect pin.	
			UART0_nCTS	I	MFP7	UART0 clear to Send input pin.	
			UART5_TXD	O	MFP8	UART5 data transmitter output pin.	
			I2C0_SCL	I/O	MFP9	I2C0 clock pin.	
			CAN0_TXD	O	MFP10	CAN0 bus transmitter output.	
			BPWM0_CH5	I/O	MFP12	BPWM0 channel 5 output/capture input.	
			EPWM0_CH0	I/O	MFP13	EPWM0 channel 0 output/capture input.	
			QEIO_INDEX	I	MFP14	Quadrature encoder 0 index input	
18	26	56	PA.4	I/O	MFP0	General purpose digital I/O pin.	
			SPIM_D3	I/O	MFP2	SPIM data 3 pin for Quad Mode I/O.	
			QSPIO_MOSI1	I/O	MFP3	Quad SPI0 MOSI1 (Master Out, Slave In) pin.	
			SPI0_I2SMCLK	I/O	MFP4	SPI0 I2S master clock output pin	
			SD1_CLK	O	MFP5	SD/SDIO1 clock output pin	
			SC0_nCD	I	MFP6	Smart Card 0 card detect pin.	
			UART0_nRTS	O	MFP7	UART0 request to Send output pin.	
			UART5_RXD	I	MFP8	UART5 data receiver input pin.	
			I2C0_SDA	I/O	MFP9	I2C0 data input/output pin.	
			CAN0_RXD	I	MFP10	CAN0 bus receiver input.	
			BPWM0_CH4	I/O	MFP12	BPWM0 channel 4 output/capture input.	
			EPWM0_CH1	I/O	MFP13	EPWM0 channel 1 output/capture input.	
			QEIO_A	I	MFP14	Quadrature encoder 0 phase A input	
11	19	27	57	PA.3	I/O	MFP0	General purpose digital I/O pin.
				SPIM_SS	I/O	MFP2	SPIM slave select pin.
				QSPIO_SS	I/O	MFP3	Quad SPI0 slave select pin.
				SPI0_SS	I/O	MFP4	SPI0 slave select pin.

32 Pin	48 Pin	64 Pin	128 Pin	Pin Name	Type	MFP	Description
				SD1_DAT3	I/O	MFP5	SD/SDIO1 data line bit 3.
				SC0_PWR	O	MFP6	Smart Card 0 power pin.
				UART4_TXD	O	MFP7	UART4 data transmitter output pin.
				UART1_TXD	O	MFP8	UART1 data transmitter output pin.
				I2C1_SCL	I/O	MFP9	I2C1 clock pin.
				BPWM0_CH3	I/O	MFP12	BPWM0 channel 3 output/capture input.
				EPWM0_CH2	I/O	MFP13	EPWM0 channel 2 output/capture input.
				QEIO_B	I	MFP14	Quadrature encoder 0 phase B input
12	20	28	58	PA.2	I/O	MFP0	General purpose digital I/O pin.
				SPIM_CLK	I/O	MFP2	SPIM serial clock pin.
				QSPIO_CLK	I/O	MFP3	Quad SPI0 serial clock pin.
				SPIO_CLK	I/O	MFP4	SPIO serial clock pin.
				SD1_DAT2	I/O	MFP5	SD/SDIO1 data line bit 2.
				SC0_RST	O	MFP6	Smart Card 0 reset pin.
				UART4_RXD	I	MFP7	UART4 data receiver input pin.
				UART1_RXD	I	MFP8	UART1 data receiver input pin.
				I2C1_SDA	I/O	MFP9	I2C1 data input/output pin.
				BPWM0_CH2	I/O	MFP12	BPWM0 channel 2 output/capture input.
				EPWM0_CH3	I/O	MFP13	EPWM0 channel 3 output/capture input.
13	21	29	59	PA.1	I/O	MFP0	General purpose digital I/O pin.
				SPIM_MISO	I/O	MFP2	SPIM MISO (Master In, Slave Out) pin.
				QSPIO_MISO0	I/O	MFP3	Quad SPI0 MISO0 (Master In, Slave Out) pin.
				SPIO_MISO	I/O	MFP4	SPIO MISO (Master In, Slave Out) pin.
				SD1_DAT1	I/O	MFP5	SD/SDIO1 data line bit 1.
				SC0_DAT	I/O	MFP6	Smart Card 0 data pin.
				UART0_TXD	O	MFP7	UART0 data transmitter output pin.
				UART1_nCTS	I	MFP8	UART1 clear to Send input pin.
				I2C2_SCL	I/O	MFP9	I2C2 clock pin.
				BPWM0_CH1	I/O	MFP12	BPWM0 channel 1 output/capture input.
				EPWM0_CH4	I/O	MFP13	EPWM0 channel 4 output/capture input.
				DAC1_ST	I	MFP15	DAC1 external trigger input.
14	22	30	60	PA.0	I/O	MFP0	General purpose digital I/O pin.
				SPIM_MOSI	I/O	MFP2	SPIM MOSI (Master Out, Slave In) pin.
				QSPIO_MOSI0	I/O	MFP3	Quad SPI0 MOSI0 (Master Out, Slave In) pin.

32 Pin	48 Pin	64 Pin	128 Pin	Pin Name	Type	MFP	Description
				SPI0_MOSI	I/O	MFP4	SPI0 MOSI (Master Out, Slave In) pin.
				SD1_DAT0	I/O	MFP5	SD/SDIO1 data line bit 0.
				SC0_CLK	O	MFP6	Smart Card 0 clock pin.
				UART0_RXD	I	MFP7	UART0 data receiver input pin.
				UART1_nRTS	O	MFP8	UART1 request to Send output pin.
				I2C2_SDA	I/O	MFP9	I2C2 data input/output pin.
				BPWM0_CH0	I/O	MFP12	BPWM0 channel 0 output/capture input.
				EPWM0_CH5	I/O	MFP13	EPWM0 channel 5 output/capture input.
				DAC0_ST	I	MFP15	DAC0 external trigger input.
15	23	31	61	V _{DDIO}	P	MFP0	Power supply for PA.0–PA.5.
			62	PE.14	I/O	MFP0	General purpose digital I/O pin.
				EBI_AD8	I/O	MFP2	EBI address/data bus bit 8.
				UART2_TXD	O	MFP3	UART2 data transmitter output pin.
				CAN0_TXD	O	MFP4	CAN0 bus transmitter output.
				SD1_nCD	I	MFP5	SD/SDIO1 card detect input pin
			63	PE.15	I/O	MFP0	General purpose digital I/O pin.
				EBI_AD9	I/O	MFP2	EBI address/data bus bit 9.
				UART2_RXD	I	MFP3	UART2 data receiver input pin.
				CAN0_RXD	I	MFP4	CAN0 bus receiver input.
16	24	32	64	nRESET	I	MFP0	External reset input: active LOW, with an internal pull-up. Set this pin low reset to initial state.
17	25	33	65	PF.0	I/O	MFP0	General purpose digital I/O pin.
				UART1_TXD	O	MFP2	UART1 data transmitter output pin.
				I2C1_SCL	I/O	MFP3	I2C1 clock pin.
				BPWM1_CH0	I/O	MFP12	BPWM1 channel 0 output/capture input.
				ICE_DAT	O	MFP14	Serial wired debugger data pin.
18	26	34	66	PF.1	I/O	MFP0	General purpose digital I/O pin.
				UART1_RXD	I	MFP2	UART1 data receiver input pin.
				I2C1_SDA	I/O	MFP3	I2C1 data input/output pin.
				BPWM1_CH1	I/O	MFP12	BPWM1 channel 1 output/capture input.
				ICE_CLK	I	MFP14	Serial wired debugger clock pin.
			67	PD.9	I/O	MFP0	General purpose digital I/O pin.
				EBI_AD7	I/O	MFP2	EBI address/data bus bit 7.
				I2C2_SCL	I/O	MFP3	I2C2 clock pin.

32 Pin	48 Pin	64 Pin	128 Pin	Pin Name	Type	MFP	Description
				UART2_nCTS	I	MFP4	UART2 clear to Send input pin.
			68	PD.8	I/O	MFP0	General purpose digital I/O pin.
				EBI_AD6	I/O	MFP2	EBI address/data bus bit 6.
				I2C2_SDA	I/O	MFP3	I2C2 data input/output pin.
				UART2_nRTS	O	MFP4	UART2 request to Send output pin.
	27	35	69	PC.5	I/O	MFP0	General purpose digital I/O pin.
				EBI_AD5	I/O	MFP2	EBI address/data bus bit 5.
				SPIM_D2	I/O	MFP3	SPIM data 2 pin for Quad Mode I/O.
				QSPI0_MISO1	I/O	MFP4	Quad SPI0 MISO1 (Master In, Slave Out) pin.
				UART2_TXD	O	MFP8	UART2 data transmitter output pin.
				I2C1_SCL	I/O	MFP9	I2C1 clock pin.
				CAN0_TXD	O	MFP10	CAN0 bus transmitter output.
				UART4_TXD	O	MFP11	UART4 data transmitter output pin.
				EPWM1_CH0	I/O	MFP12	EPWM1 channel 0 output/capture input.
	28	36	70	PC.4	I/O	MFP0	General purpose digital I/O pin.
				EBI_AD4	I/O	MFP2	EBI address/data bus bit 4.
				SPIM_D3	I/O	MFP3	SPIM data 3 pin for Quad Mode I/O.
				QSPI0_MOSI1	I/O	MFP4	Quad SPI0 MOSI1 (Master Out, Slave In) pin.
				SC1_nCD	I	MFP5	Smart Card 1 card detect pin.
				I2S0_BCLK	O	MFP6	I2S0 bit clock output pin.
				SPI1_I2SMCLK	I/O	MFP7	SPI1 I2S master clock output pin
				UART2_RXD	I	MFP8	UART2 data receiver input pin.
				I2C1_SDA	I/O	MFP9	I2C1 data input/output pin.
				CAN0_RXD	I	MFP10	CAN0 bus receiver input.
				UART4_RXD	I	MFP11	UART4 data receiver input pin.
	EPWM1_CH1	I/O	MFP12	EPWM1 channel 1 output/capture input.			
	29	37	71	PC.3	I/O	MFP0	General purpose digital I/O pin.
				EBI_AD3	I/O	MFP2	EBI address/data bus bit 3.
				SPIM_SS	I/O	MFP3	SPIM slave select pin.
				QSPI0_SS	I/O	MFP4	Quad SPI0 slave select pin.
				SC1_PWR	O	MFP5	Smart Card 1 power pin.
				I2S0_MCLK	O	MFP6	I2S0 master clock output pin.
				SPI1_MISO	I/O	MFP7	SPI1 MISO (Master In, Slave Out) pin.
				UART2_nRTS	O	MFP8	UART2 request to Send output pin.

32 Pin	48 Pin	64 Pin	128 Pin	Pin Name	Type	MFP	Description
				I2C0_SMBAL	O	MFP9	I2C0 SMBus SMBALTER pin
				CAN1_TXD	O	MFP10	CAN1 bus transmitter output.
				UART3_TXD	O	MFP11	UART3 data transmitter output pin.
				EPWM1_CH2	I/O	MFP12	EPWM1 channel 2 output/capture input.
	30	38	72	PC.2	I/O	MFP0	General purpose digital I/O pin.
				EBI_AD2	I/O	MFP2	EBI address/data bus bit 2.
				SPIM_CLK	I/O	MFP3	SPIM serial clock pin.
				QSPI0_CLK	I/O	MFP4	Quad SPI0 serial clock pin.
				SC1_RST	O	MFP5	Smart Card 1 reset pin.
				I2S0_DI	I	MFP6	I2S0 data input pin.
				SPI1_MOSI	I/O	MFP7	SPI1 MOSI (Master Out, Slave In) pin.
				UART2_nCTS	I	MFP8	UART2 clear to Send input pin.
				I2C0_SMBUSUS	O	MFP9	I2C0 SMBus SMBUSUS pin (PMBus CONTROL pin)
				CAN1_RXD	I	MFP10	CAN1 bus receiver input.
				UART3_RXD	I	MFP11	UART3 data receiver input pin.
				EPWM1_CH3	I/O	MFP12	EPWM1 channel 3 output/capture input.
19	31	39	73	PC.1	I/O	MFP0	General purpose digital I/O pin.
				EBI_AD1	I/O	MFP2	EBI address/data bus bit 1.
				SPIM_MISO	I/O	MFP3	SPIM MISO (Master In, Slave Out) pin.
				QSPI0_MISO0	I/O	MFP4	Quad SPI0 MISO0 (Master In, Slave Out) pin.
				SC1_DAT	I/O	MFP5	Smart Card 1 data pin.
				I2S0_DO	O	MFP6	I2S0 data output pin.
				SPI1_CLK	I/O	MFP7	SPI1 serial clock pin.
				UART2_TXD	O	MFP8	UART2 data transmitter output pin.
				I2C0_SCL	I/O	MFP9	I2C0 clock pin.
				EPWM1_CH4	I/O	MFP12	EPWM1 channel 4 output/capture input.
				ACMP0_O	O	MFP14	Analog comparator 0 output pin.
20	32	40	74	PC.0	I/O	MFP0	General purpose digital I/O pin.
				EBI_AD0	I/O	MFP2	EBI address/data bus bit 0.
				SPIM_MOSI	I/O	MFP3	SPIM MOSI (Master Out, Slave In) pin.
				QSPI0_MOSI0	I/O	MFP4	Quad SPI0 MOSI0 (Master Out, Slave In) pin.
				SC1_CLK	O	MFP5	Smart Card 1 clock pin.
				I2S0_LRCK	O	MFP6	I2S0 left right channel clock output pin.
				SPI1_SS	I/O	MFP7	SPI1 slave select pin.

32 Pin	48 Pin	64 Pin	128 Pin	Pin Name	Type	MFP	Description
				UART2_RXD	I	MFP8	UART2 data receiver input pin.
				I2C0_SDA	I/O	MFP9	I2C0 data input/output pin.
				EPWM1_CH5	I/O	MFP12	EPWM1 channel 5 output/capture input.
				ACMP1_O	O	MFP14	Analog comparator 1 output pin.
			75	VSS	P	MFP0	Ground pin for digital circuit.
			76	VDD	P	MFP0	Power supply for I/O ports and LDO source for internal PLL and digital circuit.
			77	PG.9	I/O	MFP0	General purpose digital I/O pin.
				EBI_AD0	I/O	MFP2	EBI address/data bus bit 0.
				SD1_DAT3	I/O	MFP3	SD/SDIO1 data line bit 3.
				SPIM_D2	I/O	MFP4	SPIM data 2 pin for Quad Mode I/O.
				BPWM0_CH5	I/O	MFP12	BPWM0 channel 5 output/capture input.
			78	PG.10	I/O	MFP0	General purpose digital I/O pin.
				EBI_AD1	I/O	MFP2	EBI address/data bus bit 1.
				SD1_DAT2	I/O	MFP3	SD/SDIO1 data line bit 2.
				SPIM_D3	I/O	MFP4	SPIM data 3 pin for Quad Mode I/O.
				BPWM0_CH4	I/O	MFP12	BPWM0 channel 4 output/capture input.
			79	PG.11	I/O	MFP0	General purpose digital I/O pin.
				EBI_AD2	I/O	MFP2	EBI address/data bus bit 2.
				SD1_DAT1	I/O	MFP3	SD/SDIO1 data line bit 1.
				SPIM_SS	I/O	MFP4	SPIM slave select pin.
				BPWM0_CH3	I/O	MFP12	BPWM0 channel 3 output/capture input.
			80	PG.12	I/O	MFP0	General purpose digital I/O pin.
				EBI_AD3	I/O	MFP2	EBI address/data bus bit 3.
				SD1_DAT0	I/O	MFP3	SD/SDIO1 data line bit 0.
				SPIM_CLK	I/O	MFP4	SPIM serial clock pin.
				BPWM0_CH2	I/O	MFP12	BPWM0 channel 2 output/capture input.
			81	PG.13	I/O	MFP0	General purpose digital I/O pin.
				EBI_AD4	I/O	MFP2	EBI address/data bus bit 4.
				SD1_CMD	I/O	MFP3	SD/SDIO1 command/response pin
				SPIM_MISO	I/O	MFP4	SPIM MISO (Master In, Slave Out) pin.
				BPWM0_CH1	I/O	MFP12	BPWM0 channel 1 output/capture input.
			82	PG.14	I/O	MFP0	General purpose digital I/O pin.
				EBI_AD5	I/O	MFP2	EBI address/data bus bit 5.

32 Pin	48 Pin	64 Pin	128 Pin	Pin Name	Type	MFP	Description
				SD1_CLK	O	MFP3	SD/SDIO1 clock output pin
				SPIM_MOSI	I/O	MFP4	SPIM MOSI (Master Out, Slave In) pin.
				BPWM0_CH0	I/O	MFP12	BPWM0 channel 0 output/capture input.
			83	PG.15	I/O	MFP0	General purpose digital I/O pin.
				SD1_nCD	I	MFP3	SD/SDIO1 card detect input pin
				CLKO	O	MFP14	Clock Out
				EADC0_ST	I	MFP15	EADC0 external trigger input.
			84	PD.13	I/O	MFP0	General purpose digital I/O pin.
				EBI_AD10	I/O	MFP2	EBI address/data bus bit 10.
				SD0_nCD	I	MFP3	SD/SDIO0 card detect input pin
				SPI0_I2SMCLK	I/O	MFP4	SPI0 I2S master clock output pin
				SPI1_I2SMCLK	I/O	MFP5	SPI1 I2S master clock output pin
				SC2_nCD	I	MFP7	Smart Card 2 card detect pin.
21	33		85	PA.12	I/O	MFP0	General purpose digital I/O pin.
				I2S0_BCLK	O	MFP2	I2S0 bit clock output pin.
				UART4_TXD	O	MFP3	UART4 data transmitter output pin.
				I2C1_SCL	I/O	MFP4	I2C1 clock pin.
				SPI2_SS	I/O	MFP5	SPI2 slave select pin.
				CAN0_TXD	O	MFP6	CAN0 bus transmitter output.
				SC2_PWR	O	MFP7	Smart Card 2 power pin.
				BPWM1_CH2	I/O	MFP11	BPWM1 channel 2 output/capture input.
				QE11_INDEX	I	MFP12	Quadrature encoder 1 index input
				USB_VBUS	P	MFP14	Power supply from USB host or HUB.
22	34		86	PA.13	I/O	MFP0	General purpose digital I/O pin.
				I2S0_MCLK	O	MFP2	I2S0 master clock output pin.
				UART4_RXD	I	MFP3	UART4 data receiver input pin.
				I2C1_SDA	I/O	MFP4	I2C1 data input/output pin.
				SPI2_CLK	I/O	MFP5	SPI2 serial clock pin.
				CAN0_RXD	I	MFP6	CAN0 bus receiver input.
				SC2_RST	O	MFP7	Smart Card 2 reset pin.
				BPWM1_CH3	I/O	MFP11	BPWM1 channel 3 output/capture input.
				QE11_A	I	MFP12	Quadrature encoder 1 phase A input
				USB_D-	A	MFP14	USB differential signal D-.
23	35		87	PA.14	I/O	MFP0	General purpose digital I/O pin.

32 Pin	48 Pin	64 Pin	128 Pin	Pin Name	Type	MFP	Description
				I2S0_DI	I	MFP2	I2S0 data input pin.
				UART0_TXD	O	MFP3	UART0 data transmitter output pin.
				SPI2_MISO	I/O	MFP5	SPI2 MISO (Master In, Slave Out) pin.
				I2C2_SCL	I/O	MFP6	I2C2 clock pin.
				SC2_DAT	I/O	MFP7	Smart Card 2 data pin.
				BPWM1_CH4	I/O	MFP11	BPWM1 channel 4 output/capture input.
				QE11_B	I	MFP12	Quadrature encoder 1 phase B input
				USB_D+	A	MFP14	USB differential signal D+.
24	36		88	PA.15	I/O	MFP0	General purpose digital I/O pin.
				I2S0_DO	O	MFP2	I2S0 data output pin.
				UART0_RXD	I	MFP3	UART0 data receiver input pin.
				SPI2_MOSI	I/O	MFP5	SPI2 MOSI (Master Out, Slave In) pin.
				I2C2_SDA	I/O	MFP6	I2C2 data input/output pin.
				SC2_CLK	O	MFP7	Smart Card 2 clock pin.
				BPWM1_CH5	I/O	MFP11	BPWM1 channel 5 output/capture input.
				EPWM0_SYNC_IN	I	MFP12	EPWM0 counter synchronous trigger input pin.
				USB_OTG_ID	I	MFP14	USB_ identification.
		41	89	HSUSB_VRES	A	MFP0	HSUSB module reference resistor
		42	90	HSUSB_VDD33	P	MFP0	Power supply for HSUSB VDD33
		43	91	HSUSB_VBUS	P	MFP0	HSUSB Power supply from USB host or HUB.
		44	92	HSUSB_D-	A	MFP0	HSUSB differential signal D-.
		45	93	HSUSB_VSS	P	MFP0	Ground pin for HSUSB.
		46	94	HSUSB_D+	A	MFP0	HSUSB differential signal D+.
		47	95	HSUSB_VDD12_CAP	A	MFP0	HSUSB Internal power regulator output 1.2V decoupling pin. Note: This pin needs to be connected with a 1uF capacitor.
		48	96	HSUSB_ID	I	MFP0	HSUSB identification.
			97	PE.7	I/O	MFP0	General purpose digital I/O pin.
				SD0_CMD	I/O	MFP3	SD/SDIO0 command/response pin
				SPIM_D2	I/O	MFP4	SPIM data 2 pin for Quad Mode I/O.
				UART5_TXD	O	MFP8	UART5 data transmitter output pin.
				CAN1_TXD	O	MFP9	CAN1 bus transmitter output.
				QE11_INDEX	I	MFP11	Quadrature encoder 1 index input
				EPWM0_CH0	I/O	MFP12	EPWM0 channel 0 output/capture input.

32 Pin	48 Pin	64 Pin	128 Pin	Pin Name	Type	MFP	Description
				BPWM0_CH5	I/O	MFP13	BPWM0 channel 5 output/capture input.
			98	PE.6	I/O	MFP0	General purpose digital I/O pin.
				SD0_CLK	O	MFP3	SD/SDIO0 clock output pin
				SPIM_D3	I/O	MFP4	SPIM data 3 pin for Quad Mode I/O.
				SPI3_I2SMCLK	I/O	MFP5	SPI3 I2S master clock output pin
				SC0_nCD	I	MFP6	Smart Card 0 card detect pin.
				USCI0_CTL0	I/O	MFP7	USCI0 control 0 pin.
				UART5_RXD	I	MFP8	UART5 data receiver input pin.
				CAN1_RXD	I	MFP9	CAN1 bus receiver input.
				QE11_A	I	MFP11	Quadrature encoder 1 phase A input
				EPWM0_CH1	I/O	MFP12	EPWM0 channel 1 output/capture input.
				BPWM0_CH4	I/O	MFP13	BPWM0 channel 4 output/capture input.
			99	PE.5	I/O	MFP0	General purpose digital I/O pin.
				EBI_nRD	O	MFP2	EBI read enable output pin.
				SD0_DAT3	I/O	MFP3	SD/SDIO0 data line bit 3.
				SPIM_SS	I/O	MFP4	SPIM slave select pin.
				SPI3_SS	I/O	MFP5	SPI3 slave select pin.
				SC0_PWR	O	MFP6	Smart Card 0 power pin.
				USCI0_CTL1	I/O	MFP7	USCI0 control 1 pin.
				QE11_B	I	MFP11	Quadrature encoder 1 phase B input
				EPWM0_CH2	I/O	MFP12	EPWM0 channel 2 output/capture input.
				BPWM0_CH3	I/O	MFP13	BPWM0 channel 3 output/capture input.
			100	PE.4	I/O	MFP0	General purpose digital I/O pin.
				EBI_nWR	O	MFP2	EBI write enable output pin.
				SD0_DAT2	I/O	MFP3	SD/SDIO0 data line bit 2.
				SPIM_CLK	I/O	MFP4	SPIM serial clock pin.
				SPI3_CLK	I/O	MFP5	SPI3 serial clock pin.
				SC0_RST	O	MFP6	Smart Card 0 reset pin.
				USCI0_DAT1	I/O	MFP7	USCI0 data 1 pin.
				QE10_INDEX	I	MFP11	Quadrature encoder 0 index input
				EPWM0_CH3	I/O	MFP12	EPWM0 channel 3 output/capture input.
				BPWM0_CH2	I/O	MFP13	BPWM0 channel 2 output/capture input.
			101	PE.3	I/O	MFP0	General purpose digital I/O pin.
				EBI_MCLK	O	MFP2	EBI external clock output pin.

32 Pin	48 Pin	64 Pin	128 Pin	Pin Name	Type	MFP	Description
				SD0_DAT1	I/O	MFP3	SD/SDIO0 data line bit 1.
				SPIM_MISO	I/O	MFP4	SPIM MISO (Master In, Slave Out) pin.
				SPI3_MISO	I/O	MFP5	SPI3 MISO (Master In, Slave Out) pin.
				SC0_DAT	I/O	MFP6	Smart Card 0 data pin.
				USCI0_DAT0	I/O	MFP7	USCI0 data 0 pin.
				QEI0_A	I	MFP11	Quadrature encoder 0 phase A input
				EPWM0_CH4	I/O	MFP12	EPWM0 channel 4 output/capture input.
				BPWM0_CH1	I/O	MFP13	BPWM0 channel 1 output/capture input.
			102	PE.2	I/O	MFP0	General purpose digital I/O pin.
				EBI_ALE	O	MFP2	EBI address latch enable output pin.
				SD0_DAT0	I/O	MFP3	SD/SDIO0 data line bit 0.
				SPIM_MOSI	I/O	MFP4	SPIM MOSI (Master Out, Slave In) pin.
				SPI3_MOSI	I/O	MFP5	SPI3 MOSI (Master Out, Slave In) pin.
				SC0_CLK	O	MFP6	Smart Card 0 clock pin.
				USCI0_CLK	I/O	MFP7	USCI0 clock pin.
				QEI0_B	I	MFP11	Quadrature encoder 0 phase B input
				EPWM0_CH5	I/O	MFP12	EPWM0 channel 5 output/capture input.
				BPWM0_CH0	I/O	MFP13	BPWM0 channel 0 output/capture input.
			103	VSS	P	MFP0	Ground pin for digital circuit.
			104	V _{DD}	P	MFP0	Power supply for I/O ports and LDO source for internal PLL and digital circuit.
			105	PE.1	I/O	MFP0	General purpose digital I/O pin.
				EBI_AD10	I/O	MFP2	EBI address/data bus bit 10.
				QSPI0_MISO0	I/O	MFP3	Quad SPI0 MISO0 (Master In, Slave Out) pin.
				SC2_DAT	I/O	MFP4	Smart Card 2 data pin.
				I2S0_BCLK	O	MFP5	I2S0 bit clock output pin.
				SPI1_MISO	I/O	MFP6	SPI1 MISO (Master In, Slave Out) pin.
				UART3_TXD	O	MFP7	UART3 data transmitter output pin.
				I2C1_SCL	I/O	MFP8	I2C1 clock pin.
				UART4_nCTS	I	MFP9	UART4 clear to Send input pin.
			106	PE.0	I/O	MFP0	General purpose digital I/O pin.
				EBI_AD11	I/O	MFP2	EBI address/data bus bit 11.
				QSPI0_MOSI0	I/O	MFP3	Quad SPI0 MOSI0 (Master Out, Slave In) pin.
				SC2_CLK	O	MFP4	Smart Card 2 clock pin.

32 Pin	48 Pin	64 Pin	128 Pin	Pin Name	Type	MFP	Description
				I2S0_MCLK	O	MFP5	I2S0 master clock output pin.
				SPI1_MOSI	I/O	MFP6	SPI1 MOSI (Master Out, Slave In) pin.
				UART3_RXD	I	MFP7	UART3 data receiver input pin.
				I2C1_SDA	I/O	MFP8	I2C1 data input/output pin.
				UART4_nRTS	O	MFP9	UART4 request to Send output pin.
			107	PH.8	I/O	MFP0	General purpose digital I/O pin.
				EBI_AD12	I/O	MFP2	EBI address/data bus bit 12.
				QSPI0_CLK	I/O	MFP3	Quad SPI0 serial clock pin.
				SC2_PWR	O	MFP4	Smart Card 2 power pin.
				I2S0_DI	I	MFP5	I2S0 data input pin.
				SPI1_CLK	I/O	MFP6	SPI1 serial clock pin.
				UART3_nRTS	O	MFP7	UART3 request to Send output pin.
				I2C1_SMBAL	O	MFP8	I2C1 SMBus SMBALTER pin
				I2C2_SCL	I/O	MFP9	I2C2 clock pin.
				UART1_TXD	O	MFP10	UART1 data transmitter output pin.
			108	PH.9	I/O	MFP0	General purpose digital I/O pin.
				EBI_AD13	I/O	MFP2	EBI address/data bus bit 13.
				QSPI0_SS	I/O	MFP3	Quad SPI0 slave select pin.
				SC2_RST	O	MFP4	Smart Card 2 reset pin.
				I2S0_DO	O	MFP5	I2S0 data output pin.
				SPI1_SS	I/O	MFP6	SPI1 slave select pin.
				UART3_nCTS	I	MFP7	UART3 clear to Send input pin.
				I2C1_SMBUSUS	O	MFP8	I2C1 SMBus SMBUSUS pin (PMBus CONTROL pin)
				I2C2_SDA	I/O	MFP9	I2C2 data input/output pin.
				UART1_RXD	I	MFP10	UART1 data receiver input pin.
			109	PH.10	I/O	MFP0	General purpose digital I/O pin.
				EBI_AD14	I/O	MFP2	EBI address/data bus bit 14.
				QSPI0_MISO1	I/O	MFP3	Quad SPI0 MISO1 (Master In, Slave Out) pin.
				SC2_nCD	I	MFP4	Smart Card 2 card detect pin.
				I2S0_LRCK	O	MFP5	I2S0 left right channel clock output pin.
				SPI1_I2SMCLK	I/O	MFP6	SPI1 I2S master clock output pin
				UART4_TXD	O	MFP7	UART4 data transmitter output pin.
				UART0_TXD	O	MFP8	UART0 data transmitter output pin.
			110	PH.11	I/O	MFP0	General purpose digital I/O pin.

32 Pin	48 Pin	64 Pin	128 Pin	Pin Name	Type	MFP	Description
				EBI_AD15	I/O	MFP2	EBI address/data bus bit 15.
				QSPI0_MOSI1	I/O	MFP3	Quad SPI0 MOSI1 (Master Out, Slave In) pin.
				UART4_RXD	I	MFP7	UART4 data receiver input pin.
				UART0_RXD	I	MFP8	UART0 data receiver input pin.
				EPWM0_CH5	I/O	MFP11	EPWM0 channel 5 output/capture input.
			111	PD.14	I/O	MFP0	General purpose digital I/O pin.
				EBI_nCS0	O	MFP2	EBI chip select 0 output pin.
				SPI3_I2SMCLK	I/O	MFP3	SPI3 I2S master clock output pin
				SC1_nCD	I	MFP4	Smart Card 1 card detect pin.
				EPWM0_CH4	I/O	MFP11	EPWM0 channel 4 output/capture input.
25	37	49	112	VSS	P	MFP0	Ground pin for digital circuit.
26	38	50	113	LDO_CAP	A	MFP0	LDO output pin.
27	39	51	114	V _{DD}	P	MFP0	Power supply for I/O ports and LDO source for internal PLL and digital circuit.
	40	52	115	PC.14	I/O	MFP0	General purpose digital I/O pin.
				EBI_AD11	I/O	MFP2	EBI address/data bus bit 11.
				SC1_nCD	I	MFP3	Smart Card 1 card detect pin.
				SPI0_I2SMCLK	I/O	MFP4	SPI0 I2S master clock output pin
				USCI0_CTL0	I/O	MFP5	USCI0 control 0 pin.
				QSPI0_CLK	I/O	MFP6	Quad SPI0 serial clock pin.
				EPWM0_SYNC_IN	I	MFP11	EPWM0 counter synchronous trigger input pin.
				TM1	I/O	MFP13	Timer1 event counter input/toggle output pin.
				USB_VBUS_ST	I	MFP14	USB external VBUS regulator status pin.
				HSUSB_VBUS_ST	I	MFP15	HSUSB external VBUS regulator status pin.
28	41	53	116	PB.15	I/O	MFP0	General purpose digital I/O pin.
				EADC0_CH15	A	MFP1	EADC0 channel 15 analog input.
				EBI_AD12	I/O	MFP2	EBI address/data bus bit 12.
				SC1_PWR	O	MFP3	Smart Card 1 power pin.
				SPI0_SS	I/O	MFP4	SPI0 slave select pin.
				USCI0_CTL1	I/O	MFP5	USCI0 control 1 pin.
				UART0_nCTS	I	MFP6	UART0 clear to Send input pin.
				UART3_TXD	O	MFP7	UART3 data transmitter output pin.
				I2C2_SMBAL	O	MFP8	I2C2 SMBus SMBALTER pin
				EPWM1_CH0	I/O	MFP11	EPWM1 channel 0 output/capture input.

32 Pin	48 Pin	64 Pin	128 Pin	Pin Name	Type	MFP	Description
				TM0_EXT	I/O	MFP13	Timer0 external capture input/toggle output pin.
				USB_VBUS_EN	O	MFP14	USB external VBUS regulator enable pin.
				HSUSB_VBUS_EN	O	MFP15	HSUSB external VBUS regulator enable pin.
29	42	54	117	PB.14	I/O	MFP0	General purpose digital I/O pin.
				EADC0_CH14	A	MFP1	EADC0 channel 14 analog input.
				EBI_AD13	I/O	MFP2	EBI address/data bus bit 13.
				SC1_RST	O	MFP3	Smart Card 1 reset pin.
				SPI0_CLK	I/O	MFP4	SPI0 serial clock pin.
				USCI0_DAT1	I/O	MFP5	USCI0 data 1 pin.
				UART0_nRTS	O	MFP6	UART0 request to Send output pin.
				UART3_RXD	I	MFP7	UART3 data receiver input pin.
				I2C2_SMBUS	O	MFP8	I2C2 SMBus SMBUS pin (PMBus CONTROL pin)
				EPWM1_CH1	I/O	MFP11	EPWM1 channel 1 output/capture input.
				TM1_EXT	I/O	MFP13	Timer1 external capture input/toggle output pin.
				CLKO	O	MFP14	Clock Out
30	43	55	118	PB.13	I/O	MFP0	General purpose digital I/O pin.
				EADC0_CH13	A	MFP1	EADC0 channel 13 analog input.
				DAC1_OUT	A	MFP1	DAC1 channel analog output.
				ACMP0_P3	A	MFP1	Analog comparator 0 positive input 3 pin.
				ACMP1_P3	A	MFP1	Analog comparator 1 positive input 3 pin.
				EBI_AD14	I/O	MFP2	EBI address/data bus bit 14.
				SC1_DAT	I/O	MFP3	Smart Card 1 data pin.
				SPI0_MISO	I/O	MFP4	SPI0 MISO (Master In, Slave Out) pin.
				USCI0_DAT0	I/O	MFP5	USCI0 data 0 pin.
				UART0_TXD	O	MFP6	UART0 data transmitter output pin.
				UART3_nRTS	O	MFP7	UART3 request to Send output pin.
				I2C2_SCL	I/O	MFP8	I2C2 clock pin.
				EPWM1_CH2	I/O	MFP11	EPWM1 channel 2 output/capture input.
				TM2_EXT	I/O	MFP13	Timer2 external capture input/toggle output pin.
31	44	56	119	PB.12	I/O	MFP0	General purpose digital I/O pin.
				EADC0_CH12	A	MFP1	EADC0 channel 12 analog input.
				DAC0_OUT	A	MFP1	DAC0 channel analog output.
				ACMP0_P2	A	MFP1	Analog comparator 0 positive input 2 pin.
				ACMP1_P2	A	MFP1	Analog comparator 1 positive input 2 pin.

32 Pin	48 Pin	64 Pin	128 Pin	Pin Name	Type	MFP	Description
				EBI_AD15	I/O	MFP2	EBI address/data bus bit 15.
				SC1_CLK	O	MFP3	Smart Card 1 clock pin.
				SPI0_MOSI	I/O	MFP4	SPI0 MOSI (Master Out, Slave In) pin.
				USCI0_CLK	I/O	MFP5	USCI0 clock pin.
				UART0_RXD	I	MFP6	UART0 data receiver input pin.
				UART3_nCTS	I	MFP7	UART3 clear to Send input pin.
				I2C2_SDA	I/O	MFP8	I2C2 data input/output pin.
				SD0_nCD	I	MFP9	SD/SDIO0 card detect input pin
				EPWM1_CH3	I/O	MFP11	EPWM1 channel 3 output/capture input.
				TM3_EXT	I/O	MFP13	Timer3 external capture input/toggle output pin.
32	45	57	120	AV _{DD}	P	MFP0	Power supply for internal analog circuit.
		58	121	V _{REF}	A	MFP0	ADC reference voltage input. Note: This pin needs to be connected with a 1uF capacitor.
	46	59	122	AVSS	P	MFP0	Ground pin for analog circuit.
		60	123	PB.11	I/O	MFP0	General purpose digital I/O pin.
				EADC0_CH11	A	MFP1	EADC0 channel 11 analog input.
				EBI_ADR16	O	MFP2	EBI address bus bit 16.
				UART0_nCTS	I	MFP5	UART0 clear to Send input pin.
				UART4_TXD	O	MFP6	UART4 data transmitter output pin.
				I2C1_SCL	I/O	MFP7	I2C1 clock pin.
				CAN0_TXD	O	MFP8	CAN0 bus transmitter output.
				SPI0_I2SMCLK	I/O	MFP9	SPI0 I2S master clock output pin
				BPWM1_CH0	I/O	MFP10	BPWM1 channel 0 output/capture input.
				SPI3_CLK	I/O	MFP11	SPI3 serial clock pin.
				HSUSB_VBUS_ST	I	MFP14	HSUSB external VBUS regulator status pin.
		61	124	PB.10	I/O	MFP0	General purpose digital I/O pin.
				EADC0_CH10	A	MFP1	EADC0 channel 10 analog input.
				EBI_ADR17	O	MFP2	EBI address bus bit 17.
				USCI1_CTL0	I/O	MFP4	USCI1 control 0 pin.
				UART0_nRTS	O	MFP5	UART0 request to Send output pin.
				UART4_RXD	I	MFP6	UART4 data receiver input pin.
				I2C1_SDA	I/O	MFP7	I2C1 data input/output pin.
				CAN0_RXD	I	MFP8	CAN0 bus receiver input.
				BPWM1_CH1	I/O	MFP10	BPWM1 channel 1 output/capture input.

32 Pin	48 Pin	64 Pin	128 Pin	Pin Name	Type	MFP	Description
				SPI3_SS	I/O	MFP11	SPI3 slave select pin.
				HSUSB_VBUS_EN	O	MFP14	HSUSB external VBUS regulator enable pin.
		62	125	PB.9	I/O	MFP0	General purpose digital I/O pin.
				EADC0_CH9	A	MFP1	EADC0 channel 9 analog input.
				EBI_ADR18	O	MFP2	EBI address bus bit 18.
				USCI1_CTL1	I/O	MFP4	USCI1 control 1 pin.
				UART0_TXD	O	MFP5	UART0 data transmitter output pin.
				UART1_nCTS	I	MFP6	UART1 clear to Send input pin.
				I2C1_SMBAL	O	MFP7	I2C1 SMBus SMBALTER pin
				BPWM1_CH2	I/O	MFP10	BPWM1 channel 2 output/capture input.
				SPI3_MISO	I/O	MFP11	SPI3 MISO (Master In, Slave Out) pin.
				INT7	I	MFP13	External interrupt 7 input pin.
		63	126	PB.8	I/O	MFP0	General purpose digital I/O pin.
				EADC0_CH8	A	MFP1	EADC0 channel 8 analog input.
				EBI_ADR19	O	MFP2	EBI address bus bit 19.
				USCI1_CLK	I/O	MFP4	USCI1 clock pin.
				UART0_RXD	I	MFP5	UART0 data receiver input pin.
				UART1_nRTS	O	MFP6	UART1 request to Send output pin.
				I2C1_SMBUSUS	O	MFP7	I2C1 SMBus SMBUSUS pin (PMBus CONTROL pin)
				BPWM1_CH3	I/O	MFP10	BPWM1 channel 3 output/capture input.
				SPI3_MOSI	I/O	MFP11	SPI3 MOSI (Master Out, Slave In) pin.
				INT6	I	MFP13	External interrupt 6 input pin.
	47	64	127	PB.7	I/O	MFP0	General purpose digital I/O pin.
				EADC0_CH7	A	MFP1	EADC0 channel 7 analog input.
				EBI_nWRL	O	MFP2	EBI low byte write enable output pin.
				USCI1_DAT0	I/O	MFP4	USCI1 data 0 pin.
				CAN1_TXD	O	MFP5	CAN1 bus transmitter output.
				UART1_TXD	O	MFP6	UART1 data transmitter output pin.
				SD1_CMD	I/O	MFP7	SD/SDIO1 command/response pin
				EBI_nCS0	O	MFP8	EBI chip select 0 output pin.
				BPWM1_CH4	I/O	MFP10	BPWM1 channel 4 output/capture input.
				EPWM1_BRAKE0	I	MFP11	EPWM1 Brake 0 input pin.
				EPWM1_CH4	I/O	MFP12	EPWM1 channel 4 output/capture input.
				INT5	I	MFP13	External interrupt 5 input pin.

32 Pin	48 Pin	64 Pin	128 Pin	Pin Name	Type	MFP	Description
				USB_VBUS_ST	I	MFP14	USB external VBUS regulator status pin.
				ACMP0_O	O	MFP15	Analog comparator 0 output pin.
	48	1	128	PB.6	I/O	MFP0	General purpose digital I/O pin.
				EADC0_CH6	A	MFP1	EADC0 channel 6 analog input.
				EBI_nWRH	O	MFP2	EBI high byte write enable output pin
				USCI1_DAT1	I/O	MFP4	USCI1 data 1 pin.
				CAN1_RXD	I	MFP5	CAN1 bus receiver input.
				UART1_RXD	I	MFP6	UART1 data receiver input pin.
				SD1_CLK	O	MFP7	SD/SDIO1 clock output pin
				EBI_nCS1	O	MFP8	EBI chip select 1 output pin.
				BPWM1_CH5	I/O	MFP10	BPWM1 channel 5 output/capture input.
				EPWM1_BRAKE1	I	MFP11	EPWM1 Brake 1 input pin.
				EPWM1_CH5	I/O	MFP12	EPWM1 channel 5 output/capture input.
				INT4	I	MFP13	External interrupt 4 input pin.
				USB_VBUS_EN	O	MFP14	USB external VBUS regulator enable pin.
				ACMP1_O	O	MFP15	Analog comparator 1 output pin.

4.2.6 M487 Series Pin Description

64 Pin	128 Pin	144 Pin	Pin Name	Type	MFP	Description
2	1	1	PB.5	I/O	MFP0	General purpose digital I/O pin.
			EADC0_CH5	A	MFP1	EADC0 channel 5 analog input.
			ACMP1_N	A	MFP1	Analog comparator 1 negative input pin.
			EBI_ADR0	O	MFP2	EBI address bus bit 0.
			SD0_DAT3	I/O	MFP3	SD/SDIO0 data line bit 3.
			EMAC_RMII_REFCLK	I	MFP4	EMAC RMII reference clock input pin.
			SPI1_MISO	I/O	MFP5	SPI1 MISO (Master In, Slave Out) pin.
			I2C0_SCL	I/O	MFP6	I2C0 clock pin.
			UART5_TXD	O	MFP7	UART5 data transmitter output pin.
			USCI1_CTL0	I/O	MFP8	USCI1 control 0 pin.
			SC0_CLK	O	MFP9	Smart Card 0 clock pin.
			I2S0_BCLK	O	MFP10	I2S0 bit clock output pin.
			EPWM0_CH0	I/O	MFP11	EPWM0 channel 0 output/capture input.
			TM0	I/O	MFP14	Timer0 event counter input/toggle output pin.
			INT0	I	MFP15	External interrupt 0 input pin.
3	2	2	PB.4	I/O	MFP0	General purpose digital I/O pin.
			EADC0_CH4	A	MFP1	EADC0 channel 4 analog input.
			ACMP1_P1	A	MFP1	Analog comparator 1 positive input 1 pin.
			EBI_ADR1	O	MFP2	EBI address bus bit 1.
			SD0_DAT2	I/O	MFP3	SD/SDIO0 data line bit 2.
			EMAC_RMII_RXD0	I	MFP4	EMAC RMII Receive Data bus bit 0.
			SPI1_MOSI	I/O	MFP5	SPI1 MOSI (Master Out, Slave In) pin.
			I2C0_SDA	I/O	MFP6	I2C0 data input/output pin.
			UART5_RXD	I	MFP7	UART5 data receiver input pin.
			USCI1_CTL1	I/O	MFP8	USCI1 control 1 pin.
			SC0_DAT	I/O	MFP9	Smart Card 0 data pin.
			I2S0_MCLK	O	MFP10	I2S0 master clock output pin.
			EPWM0_CH1	I/O	MFP11	EPWM0 channel 1 output/capture input.
			TM1	I/O	MFP14	Timer1 event counter input/toggle output pin.
			INT1	I	MFP15	External interrupt 1 input pin.
4	3	3	PB.3	I/O	MFP0	General purpose digital I/O pin.
			EADC0_CH3	A	MFP1	EADC0 channel 3 analog input.
			ACMP0_N	A	MFP1	Analog comparator 0 negative input pin.

64 Pin	128 Pin	144 Pin	Pin Name	Type	MFP	Description
			EBI_ADR2	O	MFP2	EBI address bus bit 2.
			SD0_DAT1	I/O	MFP3	SD/SDIO0 data line bit 1.
			EMAC_RMII_RXD1	I	MFP4	EMAC RMII Receive Data bus bit 1.
			SPI1_CLK	I/O	MFP5	SPI1 serial clock pin.
			UART1_TXD	O	MFP6	UART1 data transmitter output pin.
			UART5_nRTS	O	MFP7	UART5 request to Send output pin.
			USC11_DAT1	I/O	MFP8	USC11 data 1 pin.
			SC0_RST	O	MFP9	Smart Card 0 reset pin.
			I2S0_DI	I	MFP10	I2S0 data input pin.
			EPWM0_CH2	I/O	MFP11	EPWM0 channel 2 output/capture input.
			TM2	I/O	MFP14	Timer2 event counter input/toggle output pin.
			INT2	I	MFP15	External interrupt 2 input pin.
5	4	4	PB.2	I/O	MFP0	General purpose digital I/O pin.
			EADC0_CH2	A	MFP1	EADC0 channel 2 analog input.
			ACMP0_P1	A	MFP1	Analog comparator 0 positive input 1 pin.
			OPA0_O	A	MFP1	Operational amplifier 0 output pin.
			EBI_ADR3	O	MFP2	EBI address bus bit 3.
			SD0_DAT0	I/O	MFP3	SD/SDIO0 data line bit 0.
			EMAC_RMII_CRSDV	I	MFP4	EMAC RMII Carrier Sense/Receive Data input pin.
			SPI1_SS	I/O	MFP5	SPI1 slave select pin.
			UART1_RXD	I	MFP6	UART1 data receiver input pin.
			UART5_nCTS	I	MFP7	UART5 clear to Send input pin.
			USC11_DAT0	I/O	MFP8	USC11 data 0 pin.
			SC0_PWR	O	MFP9	Smart Card 0 power pin.
			I2S0_DO	O	MFP10	I2S0 data output pin.
			EPWM0_CH3	I/O	MFP11	EPWM0 channel 3 output/capture input.
			TM3	I/O	MFP14	Timer3 event counter input/toggle output pin.
			INT3	I	MFP15	External interrupt 3 input pin.
	5	5	PC.12	I/O	MFP0	General purpose digital I/O pin.
			EBI_ADR4	O	MFP2	EBI address bus bit 4.
			UART0_TXD	O	MFP3	UART0 data transmitter output pin.
			I2C0_SCL	I/O	MFP4	I2C0 clock pin.
			SPI3_MISO	I/O	MFP6	SPI3 MISO (Master In, Slave Out) pin.
			SC0_nCD	I	MFP9	Smart Card 0 card detect pin.

64 Pin	128 Pin	144 Pin	Pin Name	Type	MFP	Description
			ECAP1_IC2	I	MFP11	Enhanced capture unit 1 input 2 pin.
			EPWM1_CH0	I/O	MFP12	EPWM1 channel 0 output/capture input.
			ACMP0_O	O	MFP14	Analog comparator 0 output pin.
	6	6	PC.11	I/O	MFP0	General purpose digital I/O pin.
			EBI_ADR5	O	MFP2	EBI address bus bit 5.
			UART0_RXD	I	MFP3	UART0 data receiver input pin.
			I2C0_SDA	I/O	MFP4	I2C0 data input/output pin.
			SPI3_MOSI	I/O	MFP6	SPI3 MOSI (Master Out, Slave In) pin.
			ECAP1_IC1	I	MFP11	Enhanced capture unit 1 input 1 pin.
			EPWM1_CH1	I/O	MFP12	EPWM1 channel 1 output/capture input.
			ACMP1_O	O	MFP14	Analog comparator 1 output pin.
	7	7	PC.10	I/O	MFP0	General purpose digital I/O pin.
			EBI_ADR6	O	MFP2	EBI address bus bit 6.
			SPI3_CLK	I/O	MFP6	SPI3 serial clock pin.
			UART3_TXD	O	MFP7	UART3 data transmitter output pin.
			CAN1_TXD	O	MFP9	CAN1 bus transmitter output.
			ECAP1_IC0	I	MFP11	Enhanced capture unit 1 input 0 pin.
			EPWM1_CH2	I/O	MFP12	EPWM1 channel 2 output/capture input.
	8	8	PC.9	I/O	MFP0	General purpose digital I/O pin.
			EBI_ADR7	O	MFP2	EBI address bus bit 7.
			SPI3_SS	I/O	MFP6	SPI3 slave select pin.
			UART3_RXD	I	MFP7	UART3 data receiver input pin.
			CAN1_RXD	I	MFP9	CAN1 bus receiver input.
			EPWM1_CH3	I/O	MFP12	EPWM1 channel 3 output/capture input.
6	9	9	PB.1	I/O	MFP0	General purpose digital I/O pin.
			EADC0_CH1	A	MFP1	EADC0 channel 1 analog input.
			OPA0_N	A	MFP1	Operational amplifier 0 negative input pin.
			EBI_ADR8	O	MFP2	EBI address bus bit 8.
			SD0_CLK	O	MFP3	SD/SDIO0 clock output pin
			EMAC_RMII_RXERR	I	MFP4	EMAC RMII Receive Data Error input pin.
			SPI1_I2SMCLK	I/O	MFP5	SPI1 I2S master clock output pin
			SPI3_I2SMCLK	I/O	MFP6	SPI3 I2S master clock output pin
			UART2_TXD	O	MFP7	UART2 data transmitter output pin.
			USCI1_CLK	I/O	MFP8	USCI1 clock pin.

64 Pin	128 Pin	144 Pin	Pin Name	Type	MFP	Description
			I2C1_SCL	I/O	MFP9	I2C1 clock pin.
			I2S0_LRCK	O	MFP10	I2S0 left right channel clock output pin.
			EPWM0_CH4	I/O	MFP11	EPWM0 channel 4 output/capture input.
			EPWM1_CH4	I/O	MFP12	EPWM1 channel 4 output/capture input.
			EPWM0_BRAKE0	I	MFP13	EPWM0 Brake 0 input pin.
7	10	10	PB.0	I/O	MFP0	General purpose digital I/O pin.
			EADC0_CH0	A	MFP1	EADC0 channel 0 analog input.
			OPA0_P	A	MFP1	Operational amplifier 0 positive input pin.
			EBI_ADR9	O	MFP2	EBI address bus bit 9.
			SD0_CMD	I/O	MFP3	SD/SDIO0 command/response pin
			UART2_RXD	I	MFP7	UART2 data receiver input pin.
			SPI0_I2SMCLK	I/O	MFP8	SPI0 I2S master clock output pin
			I2C1_SDA	I/O	MFP9	I2C1 data input/output pin.
			EPWM0_CH5	I/O	MFP11	EPWM0 channel 5 output/capture input.
			EPWM1_CH5	I/O	MFP12	EPWM1 channel 5 output/capture input.
			EPWM0_BRAKE1	I	MFP13	EPWM0 Brake 1 input pin.
	11	11	V _{SS}	P	MFP0	Ground pin for digital circuit.
	12	12	V _{DD}	P	MFP0	Power supply for I/O ports and LDO source for internal PLL and digital circuit.
8	13	13	PA.11	I/O	MFP0	General purpose digital I/O pin.
			ACMP0_P0	A	MFP1	Analog comparator 0 positive input 0 pin.
			EBI_nRD	O	MFP2	EBI read enable output pin.
			SC2_PWR	O	MFP3	Smart Card 2 power pin.
			SPI2_SS	I/O	MFP4	SPI2 slave select pin.
			SD1_DAT3	I/O	MFP5	SD/SDIO1 data line bit 3.
			USCI0_CLK	I/O	MFP6	USCI0 clock pin.
			I2C2_SCL	I/O	MFP7	I2C2 clock pin.
			BPWM0_CH0	I/O	MFP9	BPWM0 channel 0 output/capture input.
			EPWM0_SYNC_OUT	O	MFP10	EPWM0 counter synchronous trigger output pin.
			TM0_EXT	I/O	MFP13	Timer0 external capture input/toggle output pin.
			DAC1_ST	I	MFP14	DAC1 external trigger input.
9	14	14	PA.10	I/O	MFP0	General purpose digital I/O pin.
			ACMP1_P0	A	MFP1	Analog comparator 1 positive input 0 pin.
			OPA1_O	A	MFP1	Operational amplifier 1 output pin.

64 Pin	128 Pin	144 Pin	Pin Name	Type	MFP	Description
			EBI_nWR	O	MFP2	EBI write enable output pin.
			SC2_RST	O	MFP3	Smart Card 2 reset pin.
			SPI2_CLK	I/O	MFP4	SPI2 serial clock pin.
			SD1_DAT2	I/O	MFP5	SD/SDIO1 data line bit 2.
			USCI0_DAT0	I/O	MFP6	USCI0 data 0 pin.
			I2C2_SDA	I/O	MFP7	I2C2 data input/output pin.
			BPWM0_CH1	I/O	MFP9	BPWM0 channel 1 output/capture input.
			QE11_INDEX	I	MFP10	Quadrature encoder 1 index input
			ECAP0_IC0	I	MFP11	Enhanced capture unit 0 input 0 pin.
			TM1_EXT	I/O	MFP13	Timer1 external capture input/toggle output pin.
			DAC0_ST	I	MFP14	DAC0 external trigger input.
10	15	15	PA.9	I/O	MFP0	General purpose digital I/O pin.
			OPA1_N	A	MFP1	Operational amplifier 1 negative input pin.
			EBI_MCLK	O	MFP2	EBI external clock output pin.
			SC2_DAT	I/O	MFP3	Smart Card 2 data pin.
			SPI2_MISO	I/O	MFP4	SPI2 MISO (Master In, Slave Out) pin.
			SD1_DAT1	I/O	MFP5	SD/SDIO1 data line bit 1.
			USCI0_DAT1	I/O	MFP6	USCI0 data 1 pin.
			UART1_TXD	O	MFP7	UART1 data transmitter output pin.
			BPWM0_CH2	I/O	MFP9	BPWM0 channel 2 output/capture input.
			QE11_A	I	MFP10	Quadrature encoder 1 phase A input
			ECAP0_IC1	I	MFP11	Enhanced capture unit 0 input 1 pin.
			TM2_EXT	I/O	MFP13	Timer2 external capture input/toggle output pin.
11	16	16	PA.8	I/O	MFP0	General purpose digital I/O pin.
			OPA1_P	A	MFP1	Operational amplifier 1 positive input pin.
			EBI_ALE	O	MFP2	EBI address latch enable output pin.
			SC2_CLK	O	MFP3	Smart Card 2 clock pin.
			SPI2_MOSI	I/O	MFP4	SPI2 MOSI (Master Out, Slave In) pin.
			SD1_DAT0	I/O	MFP5	SD/SDIO1 data line bit 0.
			USCI0_CTL1	I/O	MFP6	USCI0 control 1 pin.
			UART1_RXD	I	MFP7	UART1 data receiver input pin.
			BPWM0_CH3	I/O	MFP9	BPWM0 channel 3 output/capture input.
			QE11_B	I	MFP10	Quadrature encoder 1 phase B input
			ECAP0_IC2	I	MFP11	Enhanced capture unit 0 input 2 pin.

64 Pin	128 Pin	144 Pin	Pin Name	Type	MFP	Description
			TM3_EXT	I/O	MFP13	Timer3 external capture input/toggle output pin.
			INT4	I	MFP15	External interrupt 4 input pin.
	17	17	PC.13	I/O	MFP0	General purpose digital I/O pin.
			EBI_ADR10	O	MFP2	EBI address bus bit 10.
			SC2_nCD	I	MFP3	Smart Card 2 card detect pin.
			SPI2_I2SMCLK	I/O	MFP4	SPI2 I2S master clock output pin
			CAN1_TXD	O	MFP5	CAN1 bus transmitter output.
			USCI0_CTL0	I/O	MFP6	USCI0 control 0 pin.
			UART2_TXD	O	MFP7	UART2 data transmitter output pin.
			BPWM0_CH4	I/O	MFP9	BPWM0 channel 4 output/capture input.
			CLKO	O	MFP13	Clock Out
			EADC0_ST	I	MFP14	EADC0 external trigger input.
	18	18	PD.12	I/O	MFP0	General purpose digital I/O pin.
			OPA2_O	A	MFP1	Operational amplifier 2 output pin.
			EBI_nCS0	O	MFP2	EBI chip select 0 output pin.
			CAN1_RXD	I	MFP5	CAN1 bus receiver input.
			UART2_RXD	I	MFP7	UART2 data receiver input pin.
			BPWM0_CH5	I/O	MFP9	BPWM0 channel 5 output/capture input.
			QEIO_INDEX	I	MFP10	Quadrature encoder 0 index input
			CLKO	O	MFP13	Clock Out
			EADC0_ST	I	MFP14	EADC0 external trigger input.
			INT5	I	MFP15	External interrupt 5 input pin.
	19	19	PD.11	I/O	MFP0	General purpose digital I/O pin.
			OPA2_N	A	MFP1	Operational amplifier 2 negative input pin.
			EBI_nCS1	O	MFP2	EBI chip select 1 output pin.
			UART1_TXD	O	MFP3	UART1 data transmitter output pin.
			CAN0_TXD	O	MFP4	CAN0 bus transmitter output.
			QEIO_A	I	MFP10	Quadrature encoder 0 phase A input
			INT6	I	MFP15	External interrupt 6 input pin.
	20	20	PD.10	I/O	MFP0	General purpose digital I/O pin.
			OPA2_P	A	MFP1	Operational amplifier 2 positive input pin.
			EBI_nCS2	O	MFP2	EBI chip select 2 output pin.
			UART1_RXD	I	MFP3	UART1 data receiver input pin.
			CAN0_RXD	I	MFP4	CAN0 bus receiver input.

64 Pin	128 Pin	144 Pin	Pin Name	Type	MFP	Description
			QEIO_B	I	MFP10	Quadrature encoder 0 phase B input
			INT7	I	MFP15	External interrupt 7 input pin.
		21	V _{SS}	P	MFP0	Ground pin for digital circuit.
		22	V _{DD}	P	MFP0	Power supply for I/O ports and LDO source for internal PLL and digital circuit.
		23	PG.0	I/O	MFP0	General purpose digital I/O pin.
			EBI_ADR8	O	MFP2	EBI address bus bit 8.
			I2C0_SCL	I/O	MFP4	I2C0 clock pin.
			I2C1_SMBAL	O	MFP5	I2C1 SMBus SMBALTER pin
			UART2_RXD	I	MFP6	UART2 data receiver input pin.
			CAN1_TXD	O	MFP7	CAN1 bus transmitter output.
			UART1_TXD	O	MFP8	UART1 data transmitter output pin.
		24	PG.1	I/O	MFP0	General purpose digital I/O pin.
			EBI_ADR9	O	MFP2	EBI address bus bit 9.
			SPI2_I2SMCLK	I/O	MFP3	SPI2 I2S master clock output pin
			I2C0_SDA	I/O	MFP4	I2C0 data input/output pin.
			I2C1_SMBUSUS	O	MFP5	I2C1 SMBus SMBUSUS pin (PMBus CONTROL pin)
			UART2_TXD	O	MFP6	UART2 data transmitter output pin.
			CAN1_RXD	I	MFP7	CAN1 bus receiver input.
		UART1_RXD	I	MFP8	UART1 data receiver input pin.	
	21	25	PG.2	I/O	MFP0	General purpose digital I/O pin.
			EBI_ADR11	O	MFP2	EBI address bus bit 11.
			SPI2_SS	I/O	MFP3	SPI2 slave select pin.
			I2C0_SMBAL	O	MFP4	I2C0 SMBus SMBALTER pin
			I2C1_SCL	I/O	MFP5	I2C1 clock pin.
			TM0	I/O	MFP13	Timer0 event counter input/toggle output pin.
	22	26	PG.3	I/O	MFP0	General purpose digital I/O pin.
			EBI_ADR12	O	MFP2	EBI address bus bit 12.
			SPI2_CLK	I/O	MFP3	SPI2 serial clock pin.
			I2C0_SMBUSUS	O	MFP4	I2C0 SMBus SMBUSUS pin (PMBus CONTROL pin)
			I2C1_SDA	I/O	MFP5	I2C1 data input/output pin.
			TM1	I/O	MFP13	Timer1 event counter input/toggle output pin.
	23	27	PG.4	I/O	MFP0	General purpose digital I/O pin.
			EBI_ADR13	O	MFP2	EBI address bus bit 13.

64 Pin	128 Pin	144 Pin	Pin Name	Type	MFP	Description
			SPI2_MISO	I/O	MFP3	SPI2 MISO (Master In, Slave Out) pin.
			TM2	I/O	MFP13	Timer2 event counter input/toggle output pin.
	24	28	PF.11	I/O	MFP0	General purpose digital I/O pin.
			EBI_ADR14	O	MFP2	EBI address bus bit 14.
			SPI2_MOSI	I/O	MFP3	SPI2 MOSI (Master Out, Slave In) pin.
			TAMPER5	I/O	MFP10	TAMPER detector loop pin 5.
			TM3	I/O	MFP13	Timer3 event counter input/toggle output pin.
	25	29	PF.10	I/O	MFP0	General purpose digital I/O pin.
			EBI_ADR15	O	MFP2	EBI address bus bit 15.
			SC0_nCD	I	MFP3	Smart Card 0 card detect pin.
			I2S0_BCLK	O	MFP4	I2S0 bit clock output pin.
			SPI0_I2SMCLK	I/O	MFP5	SPI0 I2S master clock output pin
			TAMPER4	I/O	MFP10	TAMPER detector loop pin 4.
	26	30	PF.9	I/O	MFP0	General purpose digital I/O pin.
			EBI_ADR16	O	MFP2	EBI address bus bit 16.
			SC0_PWR	O	MFP3	Smart Card 0 power pin.
			I2S0_MCLK	O	MFP4	I2S0 master clock output pin.
			SPI0_SS	I/O	MFP5	SPI0 slave select pin.
			TAMPER3	I/O	MFP10	TAMPER detector loop pin 3.
	27	31	PF.8	I/O	MFP0	General purpose digital I/O pin.
			EBI_ADR17	O	MFP2	EBI address bus bit 17.
			SC0_RST	O	MFP3	Smart Card 0 reset pin.
			I2S0_DI	I	MFP4	I2S0 data input pin.
			SPI0_CLK	I/O	MFP5	SPI0 serial clock pin.
			TAMPER2	I/O	MFP10	TAMPER detector loop pin 2.
	28	32	PF.7	I/O	MFP0	General purpose digital I/O pin.
			EBI_ADR18	O	MFP2	EBI address bus bit 18.
			SC0_DAT	I/O	MFP3	Smart Card 0 data pin.
			I2S0_DO	O	MFP4	I2S0 data output pin.
			SPI0_MISO	I/O	MFP5	SPI0 MISO (Master In, Slave Out) pin.
			UART4_TXD	O	MFP6	UART4 data transmitter output pin.
			TAMPER1	I/O	MFP10	TAMPER detector loop pin 1.
12	29	33	PF.6	I/O	MFP0	General purpose digital I/O pin.
			EBI_ADR19	O	MFP2	EBI address bus bit 19.

64 Pin	128 Pin	144 Pin	Pin Name	Type	MFP	Description
			SC0_CLK	O	MFP3	Smart Card 0 clock pin.
			I2S0_LRCK	O	MFP4	I2S0 left right channel clock output pin.
			SPI0_MOSI	I/O	MFP5	SPI0 MOSI (Master Out, Slave In) pin.
			UART4_RXD	I	MFP6	UART4 data receiver input pin.
			EBI_nCS0	O	MFP7	EBI chip select 0 output pin.
			TAMPER0	I/O	MFP10	TAMPER detector loop pin 0.
13	30	34	V _{DD}	P	MFP0	Power supply for I/O ports and LDO source for internal PLL and digital circuit.
14	31	35	PF.5	I/O	MFP0	General purpose digital I/O pin.
			UART2_RXD	I	MFP2	UART2 data receiver input pin.
			UART2_nCTS	I	MFP4	UART2 clear to Send input pin.
			BPWM0_CH4	I/O	MFP8	BPWM0 channel 4 output/capture input.
			EPWM0_SYNC_OUT	O	MFP9	EPWM0 counter synchronous trigger output pin.
			X32_IN	I	MFP10	External 32.768 kHz crystal input pin.
			EADC0_ST	I	MFP11	EADC0 external trigger input.
15	32	36	PF.4	I/O	MFP0	General purpose digital I/O pin.
			UART2_TXD	O	MFP2	UART2 data transmitter output pin.
			UART2_nRTS	O	MFP4	UART2 request to Send output pin.
			BPWM0_CH5	I/O	MFP8	BPWM0 channel 5 output/capture input.
			X32_OUT	O	MFP10	External 32.768 kHz crystal output pin.
		37	PH.0	I/O	MFP0	General purpose digital I/O pin.
			EBI_ADR7	O	MFP2	EBI address bus bit 7.
			UART5_TXD	O	MFP4	UART5 data transmitter output pin.
			TM0_EXT	I/O	MFP13	Timer0 external capture input/toggle output pin.
		38	PH.1	I/O	MFP0	General purpose digital I/O pin.
			EBI_ADR6	O	MFP2	EBI address bus bit 6.
			UART5_RXD	I	MFP4	UART5 data receiver input pin.
			TM1_EXT	I/O	MFP13	Timer1 external capture input/toggle output pin.
		39	PH.2	I/O	MFP0	General purpose digital I/O pin.
			EBI_ADR5	O	MFP2	EBI address bus bit 5.
			UART5_nRTS	O	MFP4	UART5 request to Send output pin.
			UART4_TXD	O	MFP5	UART4 data transmitter output pin.
			I2C0_SCL	I/O	MFP6	I2C0 clock pin.
			TM2_EXT	I/O	MFP13	Timer2 external capture input/toggle output pin.

64 Pin	128 Pin	144 Pin	Pin Name	Type	MFP	Description
		40	PH.3	I/O	MFP0	General purpose digital I/O pin.
			EBI_ADR4	O	MFP2	EBI address bus bit 4.
			SPI1_I2SMCLK	I/O	MFP3	SPI1 I2S master clock output pin
			UART5_nCTS	I	MFP4	UART5 clear to Send input pin.
			UART4_RXD	I	MFP5	UART4 data receiver input pin.
			I2C0_SDA	I/O	MFP6	I2C0 data input/output pin.
			TM3_EXT	I/O	MFP13	Timer3 external capture input/toggle output pin.
	33	41	PH.4	I/O	MFP0	General purpose digital I/O pin.
			EBI_ADR3	O	MFP2	EBI address bus bit 3.
			SPI1_MISO	I/O	MFP3	SPI1 MISO (Master In, Slave Out) pin.
	34	42	PH.5	I/O	MFP0	General purpose digital I/O pin.
			EBI_ADR2	O	MFP2	EBI address bus bit 2.
			SPI1_MOSI	I/O	MFP3	SPI1 MOSI (Master Out, Slave In) pin.
	35	43	PH.6	I/O	MFP0	General purpose digital I/O pin.
			EBI_ADR1	O	MFP2	EBI address bus bit 1.
			SPI1_CLK	I/O	MFP3	SPI1 serial clock pin.
	36	44	PH.7	I/O	MFP0	General purpose digital I/O pin.
			EBI_ADR0	O	MFP2	EBI address bus bit 0.
			SPI1_SS	I/O	MFP3	SPI1 slave select pin.
16	37	45	PF.3	I/O	MFP0	General purpose digital I/O pin.
			EBI_nCS0	O	MFP2	EBI chip select 0 output pin.
			UART0_TXD	O	MFP3	UART0 data transmitter output pin.
			I2C0_SCL	I/O	MFP4	I2C0 clock pin.
			XT1_IN	I	MFP10	External 4~24 MHz (high speed) crystal input pin.
			BPWM1_CH0	I/O	MFP11	BPWM1 channel 0 output/capture input.
17	38	46	PF.2	I/O	MFP0	General purpose digital I/O pin.
			EBI_nCS1	O	MFP2	EBI chip select 1 output pin.
			UART0_RXD	I	MFP3	UART0 data receiver input pin.
			I2C0_SDA	I/O	MFP4	I2C0 data input/output pin.
			QSPI0_CLK	I/O	MFP5	Quad SPI0 serial clock pin.
			XT1_OUT	O	MFP10	External 4~24 MHz (high speed) crystal output pin.
			BPWM1_CH1	I/O	MFP11	BPWM1 channel 1 output/capture input.
	39	47	V _{SS}	P	MFP0	Ground pin for digital circuit.
	40	48	V _{DD}	P	MFP0	Power supply for I/O ports and LDO source for internal PLL

64 Pin	128 Pin	144 Pin	Pin Name	Type	MFP	Description
						and digital circuit.
	41	49	PE.8	I/O	MFP0	General purpose digital I/O pin.
			EBI_ADR10	O	MFP2	EBI address bus bit 10.
			EMAC_RMII_MDC	O	MFP3	EMAC RMII PHY Management Clock output pin.
			I2S0_BCLK	O	MFP4	I2S0 bit clock output pin.
			SPI2_CLK	I/O	MFP5	SPI2 serial clock pin.
			USCI1_CTL1	I/O	MFP6	USCI1 control 1 pin.
			UART2_TXD	O	MFP7	UART2 data transmitter output pin.
			EPWM0_CH0	I/O	MFP10	EPWM0 channel 0 output/capture input.
			EPWM0_BRAKE0	I	MFP11	EPWM0 Brake 0 input pin.
			ECAP0_IC0	I	MFP12	Enhanced capture unit 0 input 0 pin.
			TRACE_CLK	O	MFP14	ETM Trace Clock output pin
	42	50	PE.9	I/O	MFP0	General purpose digital I/O pin.
			EBI_ADR11	O	MFP2	EBI address bus bit 11.
			EMAC_RMII_MDIO	I/O	MFP3	EMAC RMII PHY Management Data pin.
			I2S0_MCLK	O	MFP4	I2S0 master clock output pin.
			SPI2_MISO	I/O	MFP5	SPI2 MISO (Master In, Slave Out) pin.
			USCI1_CTL0	I/O	MFP6	USCI1 control 0 pin.
			UART2_RXD	I	MFP7	UART2 data receiver input pin.
			EPWM0_CH1	I/O	MFP10	EPWM0 channel 1 output/capture input.
			EPWM0_BRAKE1	I	MFP11	EPWM0 Brake 1 input pin.
			ECAP0_IC1	I	MFP12	Enhanced capture unit 0 input 1 pin.
			TRACE_DATA0	O	MFP14	ETM Trace Data 0 output pin
	43	51	PE.10	I/O	MFP0	General purpose digital I/O pin.
			EBI_ADR12	O	MFP2	EBI address bus bit 12.
			EMAC_RMII_TXD0	O	MFP3	EMAC RMII Transmit Data bus bit 0.
			I2S0_DI	I	MFP4	I2S0 data input pin.
			SPI2_MOSI	I/O	MFP5	SPI2 MOSI (Master Out, Slave In) pin.
			USCI1_DAT0	I/O	MFP6	USCI1 data 0 pin.
			UART3_TXD	O	MFP7	UART3 data transmitter output pin.
			EPWM0_CH2	I/O	MFP10	EPWM0 channel 2 output/capture input.
			EPWM1_BRAKE0	I	MFP11	EPWM1 Brake 0 input pin.
			ECAP0_IC2	I	MFP12	Enhanced capture unit 0 input 2 pin.
			TRACE_DATA1	O	MFP14	ETM Trace Data 1 output pin

64 Pin	128 Pin	144 Pin	Pin Name	Type	MFP	Description
	44	52	PE.11	I/O	MFP0	General purpose digital I/O pin.
			EBI_ADR13	O	MFP2	EBI address bus bit 13.
			EMAC_RMII_TXD1	O	MFP3	EMAC RMII Transmit Data bus bit 1.
			I2S0_DO	O	MFP4	I2S0 data output pin.
			SPI2_SS	I/O	MFP5	SPI2 slave select pin.
			USCI1_DAT1	I/O	MFP6	USCI1 data 1 pin.
			UART3_RXD	I	MFP7	UART3 data receiver input pin.
			UART1_nCTS	I	MFP8	UART1 clear to Send input pin.
			EPWM0_CH3	I/O	MFP10	EPWM0 channel 3 output/capture input.
			EPWM1_BRAKE1	I	MFP11	EPWM1 Brake 1 input pin.
			ECAP1_IC2	I	MFP13	Enhanced capture unit 1 input 2 pin.
			TRACE_DATA2	O	MFP14	ETM Trace Data 2 output pin
	45	53	PE.12	I/O	MFP0	General purpose digital I/O pin.
			EBI_ADR14	O	MFP2	EBI address bus bit 14.
			EMAC_RMII_TXEN	O	MFP3	EMAC RMII Transmit Enable output pin.
			I2S0_LRCK	O	MFP4	I2S0 left right channel clock output pin.
			SPI2_I2SMCLK	I/O	MFP5	SPI2 I2S master clock output pin
			USCI1_CLK	I/O	MFP6	USCI1 clock pin.
			UART1_nRTS	O	MFP8	UART1 request to Send output pin.
			EPWM0_CH4	I/O	MFP10	EPWM0 channel 4 output/capture input.
			ECAP1_IC1	I	MFP13	Enhanced capture unit 1 input 1 pin.
			TRACE_DATA3	O	MFP14	ETM Trace Data 3 output pin
	46	54	PE.13	I/O	MFP0	General purpose digital I/O pin.
			EBI_ADR15	O	MFP2	EBI address bus bit 15.
			EMAC_PPS	O	MFP3	EMAC Pulse Per Second output pin.
			I2C0_SCL	I/O	MFP4	I2C0 clock pin.
			UART4_nRTS	O	MFP5	UART4 request to Send output pin.
			UART1_TXD	O	MFP8	UART1 data transmitter output pin.
			EPWM0_CH5	I/O	MFP10	EPWM0 channel 5 output/capture input.
			EPWM1_CH0	I/O	MFP11	EPWM1 channel 0 output/capture input.
			BPWM1_CH5	I/O	MFP12	BPWM1 channel 5 output/capture input.
			ECAP1_IC0	I	MFP13	Enhanced capture unit 1 input 0 pin.
	47	55	PC.8	I/O	MFP0	General purpose digital I/O pin.
			EBI_ADR16	O	MFP2	EBI address bus bit 16.

64 Pin	128 Pin	144 Pin	Pin Name	Type	MFP	Description
			EMAC_RMII_REFCLK	I	MFP3	EMAC RMII reference clock input pin.
			I2C0_SDA	I/O	MFP4	I2C0 data input/output pin.
			UART4_nCTS	I	MFP5	UART4 clear to Send input pin.
			UART1_RXD	I	MFP8	UART1 data receiver input pin.
			EPWM1_CH1	I/O	MFP11	EPWM1 channel 1 output/capture input.
			BPWM1_CH4	I/O	MFP12	BPWM1 channel 4 output/capture input.
18	48	56	PC.7	I/O	MFP0	General purpose digital I/O pin.
			EBI_AD9	I/O	MFP2	EBI address/data bus bit 9.
			EMAC_RMII_RXD0	I	MFP3	EMAC RMII Receive Data bus bit 0.
			SPI1_MISO	I/O	MFP4	SPI1 MISO (Master In, Slave Out) pin.
			UART4_TXD	O	MFP5	UART4 data transmitter output pin.
			SC2_PWR	O	MFP6	Smart Card 2 power pin.
			UART0_nCTS	I	MFP7	UART0 clear to Send input pin.
			I2C1_SMBAL	O	MFP8	I2C1 SMBus SMBALTER pin
			EPWM1_CH2	I/O	MFP11	EPWM1 channel 2 output/capture input.
			BPWM1_CH0	I/O	MFP12	BPWM1 channel 0 output/capture input.
			TM0	I/O	MFP14	Timer0 event counter input/toggle output pin.
			INT3	I	MFP15	External interrupt 3 input pin.
19	49	57	PC.6	I/O	MFP0	General purpose digital I/O pin.
			EBI_AD8	I/O	MFP2	EBI address/data bus bit 8.
			EMAC_RMII_RXD1	I	MFP3	EMAC RMII Receive Data bus bit 1.
			SPI1_MOSI	I/O	MFP4	SPI1 MOSI (Master Out, Slave In) pin.
			UART4_RXD	I	MFP5	UART4 data receiver input pin.
			SC2_RST	O	MFP6	Smart Card 2 reset pin.
			UART0_nRTS	O	MFP7	UART0 request to Send output pin.
			I2C1_SMBSUS	O	MFP8	I2C1 SMBus SMBSUS pin (PMBus CONTROL pin)
			EPWM1_CH3	I/O	MFP11	EPWM1 channel 3 output/capture input.
			BPWM1_CH1	I/O	MFP12	BPWM1 channel 1 output/capture input.
			TM1	I/O	MFP14	Timer1 event counter input/toggle output pin.
			INT2	I	MFP15	External interrupt 2 input pin.
20	50	58	PA.7	I/O	MFP0	General purpose digital I/O pin.
			EBI_AD7	I/O	MFP2	EBI address/data bus bit 7.
			EMAC_RMII_CRSDV	I	MFP3	EMAC RMII Carrier Sense/Receive Data input pin.
			SPI1_CLK	I/O	MFP4	SPI1 serial clock pin.

64 Pin	128 Pin	144 Pin	Pin Name	Type	MFP	Description
			SC2_DAT	I/O	MFP6	Smart Card 2 data pin.
			UART0_TXD	O	MFP7	UART0 data transmitter output pin.
			I2C1_SCL	I/O	MFP8	I2C1 clock pin.
			EPWM1_CH4	I/O	MFP11	EPWM1 channel 4 output/capture input.
			BPWM1_CH2	I/O	MFP12	BPWM1 channel 2 output/capture input.
			ACMP0_WLAT	I	MFP13	Analog comparator 0 window latch input pin
			TM2	I/O	MFP14	Timer2 event counter input/toggle output pin.
			INT1	I	MFP15	External interrupt 1 input pin.
21	51	59	PA.6	I/O	MFP0	General purpose digital I/O pin.
			EBI_AD6	I/O	MFP2	EBI address/data bus bit 6.
			EMAC_RMII_RXERR	I	MFP3	EMAC RMII Receive Data Error input pin.
			SPI1_SS	I/O	MFP4	SPI1 slave select pin.
			SD1_nCD	I	MFP5	SD/SDIO1 card detect input pin
			SC2_CLK	O	MFP6	Smart Card 2 clock pin.
			UART0_RXD	I	MFP7	UART0 data receiver input pin.
			I2C1_SDA	I/O	MFP8	I2C1 data input/output pin.
			EPWM1_CH5	I/O	MFP11	EPWM1 channel 5 output/capture input.
			BPWM1_CH3	I/O	MFP12	BPWM1 channel 3 output/capture input.
			ACMP1_WLAT	I	MFP13	Analog comparator 1 window latch input pin
			TM3	I/O	MFP14	Timer3 event counter input/toggle output pin.
			INT0	I	MFP15	External interrupt 0 input pin.
22	52	60	V _{SS}	P	MFP0	Ground pin for digital circuit.
23	53	61	V _{DD}	P	MFP0	Power supply for I/O ports and LDO source for internal PLL and digital circuit.
24	54	62	LDO_CAP	A	MFP0	LDO output pin.
25	55	63	PA.5	I/O	MFP0	General purpose digital I/O pin.
			SPIM_D2	I/O	MFP2	SPIM data 2 pin for Quad Mode I/O.
			QSPIO_MISO1	I/O	MFP3	Quad SPI0 MISO1 (Master In, Slave Out) pin.
			SPI1_I2SMCLK	I/O	MFP4	SPI1 I2S master clock output pin
			SD1_CMD	I/O	MFP5	SD/SDIO1 command/response pin
			SC2_nCD	I	MFP6	Smart Card 2 card detect pin.
			UART0_nCTS	I	MFP7	UART0 clear to Send input pin.
			UART5_TXD	O	MFP8	UART5 data transmitter output pin.
			I2C0_SCL	I/O	MFP9	I2C0 clock pin.

64 Pin	128 Pin	144 Pin	Pin Name	Type	MFP	Description
			CAN0_TXD	O	MFP10	CAN0 bus transmitter output.
			BPWM0_CH5	I/O	MFP12	BPWM0 channel 5 output/capture input.
			EPWM0_CH0	I/O	MFP13	EPWM0 channel 0 output/capture input.
			QEIO_INDEX	I	MFP14	Quadrature encoder 0 index input
26	56	64	PA.4	I/O	MFP0	General purpose digital I/O pin.
			SPIM_D3	I/O	MFP2	SPIM data 3 pin for Quad Mode I/O.
			QSPI0_MOSI1	I/O	MFP3	Quad SPI0 MOSI1 (Master Out, Slave In) pin.
			SPI0_I2SMCLK	I/O	MFP4	SPI0 I2S master clock output pin
			SD1_CLK	O	MFP5	SD/SDIO1 clock output pin
			SC0_nCD	I	MFP6	Smart Card 0 card detect pin.
			UART0_nRTS	O	MFP7	UART0 request to Send output pin.
			UART5_RXD	I	MFP8	UART5 data receiver input pin.
			I2C0_SDA	I/O	MFP9	I2C0 data input/output pin.
			CAN0_RXD	I	MFP10	CAN0 bus receiver input.
			BPWM0_CH4	I/O	MFP12	BPWM0 channel 4 output/capture input.
			EPWM0_CH1	I/O	MFP13	EPWM0 channel 1 output/capture input.
			QEIO_A	I	MFP14	Quadrature encoder 0 phase A input
27	57	65	PA.3	I/O	MFP0	General purpose digital I/O pin.
			SPIM_SS	I/O	MFP2	SPIM slave select pin.
			QSPI0_SS	I/O	MFP3	Quad SPI0 slave select pin.
			SPI0_SS	I/O	MFP4	SPI0 slave select pin.
			SD1_DAT3	I/O	MFP5	SD/SDIO1 data line bit 3.
			SC0_PWR	O	MFP6	Smart Card 0 power pin.
			UART4_TXD	O	MFP7	UART4 data transmitter output pin.
			UART1_TXD	O	MFP8	UART1 data transmitter output pin.
			I2C1_SCL	I/O	MFP9	I2C1 clock pin.
			BPWM0_CH3	I/O	MFP12	BPWM0 channel 3 output/capture input.
			EPWM0_CH2	I/O	MFP13	EPWM0 channel 2 output/capture input.
			QEIO_B	I	MFP14	Quadrature encoder 0 phase B input
28	58	66	PA.2	I/O	MFP0	General purpose digital I/O pin.
			SPIM_CLK	I/O	MFP2	SPIM serial clock pin.
			QSPI0_CLK	I/O	MFP3	Quad SPI0 serial clock pin.
			SPI0_CLK	I/O	MFP4	SPI0 serial clock pin.
			SD1_DAT2	I/O	MFP5	SD/SDIO1 data line bit 2.

64 Pin	128 Pin	144 Pin	Pin Name	Type	MFP	Description
			SC0_RST	O	MFP6	Smart Card 0 reset pin.
			UART4_RXD	I	MFP7	UART4 data receiver input pin.
			UART1_RXD	I	MFP8	UART1 data receiver input pin.
			I2C1_SDA	I/O	MFP9	I2C1 data input/output pin.
			BPWM0_CH2	I/O	MFP12	BPWM0 channel 2 output/capture input.
			EPWM0_CH3	I/O	MFP13	EPWM0 channel 3 output/capture input.
29	59	67	PA.1	I/O	MFP0	General purpose digital I/O pin.
			SPIM_MISO	I/O	MFP2	SPIM MISO (Master In, Slave Out) pin.
			QSPI0_MISO0	I/O	MFP3	Quad SPI0 MISO0 (Master In, Slave Out) pin.
			SPI0_MISO	I/O	MFP4	SPI0 MISO (Master In, Slave Out) pin.
			SD1_DAT1	I/O	MFP5	SD/SDIO1 data line bit 1.
			SC0_DAT	I/O	MFP6	Smart Card 0 data pin.
			UART0_TXD	O	MFP7	UART0 data transmitter output pin.
			UART1_nCTS	I	MFP8	UART1 clear to Send input pin.
			I2C2_SCL	I/O	MFP9	I2C2 clock pin.
			BPWM0_CH1	I/O	MFP12	BPWM0 channel 1 output/capture input.
			EPWM0_CH4	I/O	MFP13	EPWM0 channel 4 output/capture input.
			DAC1_ST	I	MFP15	DAC1 external trigger input.
30	60	68	PA.0	I/O	MFP0	General purpose digital I/O pin.
			SPIM_MOSI	I/O	MFP2	SPIM MOSI (Master Out, Slave In) pin.
			QSPI0_MOSI0	I/O	MFP3	Quad SPI0 MOSI0 (Master Out, Slave In) pin.
			SPI0_MOSI	I/O	MFP4	SPI0 MOSI (Master Out, Slave In) pin.
			SD1_DAT0	I/O	MFP5	SD/SDIO1 data line bit 0.
			SC0_CLK	O	MFP6	Smart Card 0 clock pin.
			UART0_RXD	I	MFP7	UART0 data receiver input pin.
			UART1_nRTS	O	MFP8	UART1 request to Send output pin.
			I2C2_SDA	I/O	MFP9	I2C2 data input/output pin.
			BPWM0_CH0	I/O	MFP12	BPWM0 channel 0 output/capture input.
			EPWM0_CH5	I/O	MFP13	EPWM0 channel 5 output/capture input.
			DAC0_ST	I	MFP15	DAC0 external trigger input.
31	61	69	V _{DDIO}	P	MFP0	Power supply for PA.0~PA.5.
	62	70	PE.14	I/O	MFP0	General purpose digital I/O pin.
			EBI_AD8	I/O	MFP2	EBI address/data bus bit 8.
			UART2_TXD	O	MFP3	UART2 data transmitter output pin.

64 Pin	128 Pin	144 Pin	Pin Name	Type	MFP	Description
			CAN0_TXD	O	MFP4	CAN0 bus transmitter output.
			SD1_nCD	I	MFP5	SD/SDIO1 card detect input pin
	63	71	PE.15	I/O	MFP0	General purpose digital I/O pin.
			EBI_AD9	I/O	MFP2	EBI address/data bus bit 9.
			UART2_RXD	I	MFP3	UART2 data receiver input pin.
			CAN0_RXD	I	MFP4	CAN0 bus receiver input.
32	64	72	nRESET	I	MFP0	External reset input: active LOW, with an internal pull-up. Set this pin low reset to initial state.
33	65	73	PF.0	I/O	MFP0	General purpose digital I/O pin.
			UART1_TXD	O	MFP2	UART1 data transmitter output pin.
			I2C1_SCL	I/O	MFP3	I2C1 clock pin.
			BPWM1_CH0	I/O	MFP12	BPWM1 channel 0 output/capture input.
			ICE_DAT	O	MFP14	Serial wired debugger data pin.
34	66	74	PF.1	I/O	MFP0	General purpose digital I/O pin.
			UART1_RXD	I	MFP2	UART1 data receiver input pin.
			I2C1_SDA	I/O	MFP3	I2C1 data input/output pin.
			BPWM1_CH1	I/O	MFP12	BPWM1 channel 1 output/capture input.
			ICE_CLK	I	MFP14	Serial wired debugger clock pin.
	67	75	PD.9	I/O	MFP0	General purpose digital I/O pin.
			EBI_AD7	I/O	MFP2	EBI address/data bus bit 7.
			I2C2_SCL	I/O	MFP3	I2C2 clock pin.
			UART2_nCTS	I	MFP4	UART2 clear to Send input pin.
	68	76	PD.8	I/O	MFP0	General purpose digital I/O pin.
			EBI_AD6	I/O	MFP2	EBI address/data bus bit 6.
			I2C2_SDA	I/O	MFP3	I2C2 data input/output pin.
			UART2_nRTS	O	MFP4	UART2 request to Send output pin.
35	69	77	PC.5	I/O	MFP0	General purpose digital I/O pin.
			EBI_AD5	I/O	MFP2	EBI address/data bus bit 5.
			SPIM_D2	I/O	MFP3	SPIM data 2 pin for Quad Mode I/O.
			QSPI0_MISO1	I/O	MFP4	Quad SPI0 MISO1 (Master In, Slave Out) pin.
			UART2_TXD	O	MFP8	UART2 data transmitter output pin.
			I2C1_SCL	I/O	MFP9	I2C1 clock pin.
			CAN0_TXD	O	MFP10	CAN0 bus transmitter output.
			UART4_TXD	O	MFP11	UART4 data transmitter output pin.

64 Pin	128 Pin	144 Pin	Pin Name	Type	MFP	Description
			EPWM1_CH0	I/O	MFP12	EPWM1 channel 0 output/capture input.
36	70	78	PC.4	I/O	MFP0	General purpose digital I/O pin.
			EBI_AD4	I/O	MFP2	EBI address/data bus bit 4.
			SPIM_D3	I/O	MFP3	SPIM data 3 pin for Quad Mode I/O.
			QSPI0_MOSI1	I/O	MFP4	Quad SPI0 MOSI1 (Master Out, Slave In) pin.
			SC1_nCD	I	MFP5	Smart Card 1 card detect pin.
			I2S0_BCLK	O	MFP6	I2S0 bit clock output pin.
			SPI1_I2SMCLK	I/O	MFP7	SPI1 I2S master clock output pin
			UART2_RXD	I	MFP8	UART2 data receiver input pin.
			I2C1_SDA	I/O	MFP9	I2C1 data input/output pin.
			CAN0_RXD	I	MFP10	CAN0 bus receiver input.
			UART4_RXD	I	MFP11	UART4 data receiver input pin.
			EPWM1_CH1	I/O	MFP12	EPWM1 channel 1 output/capture input.
37	71	79	PC.3	I/O	MFP0	General purpose digital I/O pin.
			EBI_AD3	I/O	MFP2	EBI address/data bus bit 3.
			SPIM_SS	I/O	MFP3	SPIM slave select pin.
			QSPI0_SS	I/O	MFP4	Quad SPI0 slave select pin.
			SC1_PWR	O	MFP5	Smart Card 1 power pin.
			I2S0_MCLK	O	MFP6	I2S0 master clock output pin.
			SPI1_MISO	I/O	MFP7	SPI1 MISO (Master In, Slave Out) pin.
			UART2_nRTS	O	MFP8	UART2 request to Send output pin.
			I2C0_SMBAL	O	MFP9	I2C0 SMBus SMBALTER pin
			CAN1_TXD	O	MFP10	CAN1 bus transmitter output.
			UART3_TXD	O	MFP11	UART3 data transmitter output pin.
			EPWM1_CH2	I/O	MFP12	EPWM1 channel 2 output/capture input.
38	72	80	PC.2	I/O	MFP0	General purpose digital I/O pin.
			EBI_AD2	I/O	MFP2	EBI address/data bus bit 2.
			SPIM_CLK	I/O	MFP3	SPIM serial clock pin.
			QSPI0_CLK	I/O	MFP4	Quad SPI0 serial clock pin.
			SC1_RST	O	MFP5	Smart Card 1 reset pin.
			I2S0_DI	I	MFP6	I2S0 data input pin.
			SPI1_MOSI	I/O	MFP7	SPI1 MOSI (Master Out, Slave In) pin.
			UART2_nCTS	I	MFP8	UART2 clear to Send input pin.
			I2C0_SMBSUS	O	MFP9	I2C0 SMBus SMBSUS pin (PMBus CONTROL pin)

64 Pin	128 Pin	144 Pin	Pin Name	Type	MFP	Description
			CAN1_RXD	I	MFP10	CAN1 bus receiver input.
			UART3_RXD	I	MFP11	UART3 data receiver input pin.
			EPWM1_CH3	I/O	MFP12	EPWM1 channel 3 output/capture input.
39	73	81	PC.1	I/O	MFP0	General purpose digital I/O pin.
			EBI_AD1	I/O	MFP2	EBI address/data bus bit 1.
			SPIM_MISO	I/O	MFP3	SPIM MISO (Master In, Slave Out) pin.
			QSPI0_MISO0	I/O	MFP4	Quad SPI0 MISO0 (Master In, Slave Out) pin.
			SC1_DAT	I/O	MFP5	Smart Card 1 data pin.
			I2S0_DO	O	MFP6	I2S0 data output pin.
			SPI1_CLK	I/O	MFP7	SPI1 serial clock pin.
			UART2_TXD	O	MFP8	UART2 data transmitter output pin.
			I2C0_SCL	I/O	MFP9	I2C0 clock pin.
			EPWM1_CH4	I/O	MFP12	EPWM1 channel 4 output/capture input.
			ACMP0_O	O	MFP14	Analog comparator 0 output pin.
40	74	82	PC.0	I/O	MFP0	General purpose digital I/O pin.
			EBI_AD0	I/O	MFP2	EBI address/data bus bit 0.
			SPIM_MOSI	I/O	MFP3	SPIM MOSI (Master Out, Slave In) pin.
			QSPI0_MOSI0	I/O	MFP4	Quad SPI0 MOSI0 (Master Out, Slave In) pin.
			SC1_CLK	O	MFP5	Smart Card 1 clock pin.
			I2S0_LRCK	O	MFP6	I2S0 left right channel clock output pin.
			SPI1_SS	I/O	MFP7	SPI1 slave select pin.
			UART2_RXD	I	MFP8	UART2 data receiver input pin.
			I2C0_SDA	I/O	MFP9	I2C0 data input/output pin.
			EPWM1_CH5	I/O	MFP12	EPWM1 channel 5 output/capture input.
			ACMP1_O	O	MFP14	Analog comparator 1 output pin.
	75	83	V _{SS}	P	MFP0	Ground pin for digital circuit.
	76	84	V _{DD}	P	MFP0	Power supply for I/O ports and LDO source for internal PLL and digital circuit.
	77	85	PG.9	I/O	MFP0	General purpose digital I/O pin.
			EBI_AD0	I/O	MFP2	EBI address/data bus bit 0.
			SD1_DAT3	I/O	MFP3	SD/SDIO1 data line bit 3.
			SPIM_D2	I/O	MFP4	SPIM data 2 pin for Quad Mode I/O.
			BPWM0_CH5	I/O	MFP12	BPWM0 channel 5 output/capture input.
	78	86	PG.10	I/O	MFP0	General purpose digital I/O pin.

64 Pin	128 Pin	144 Pin	Pin Name	Type	MFP	Description
			EBI_AD1	I/O	MFP2	EBI address/data bus bit 1.
			SD1_DAT2	I/O	MFP3	SD/SDIO1 data line bit 2.
			SPIM_D3	I/O	MFP4	SPIM data 3 pin for Quad Mode I/O.
			BPWM0_CH4	I/O	MFP12	BPWM0 channel 4 output/capture input.
	79	87	PG.11	I/O	MFP0	General purpose digital I/O pin.
			EBI_AD2	I/O	MFP2	EBI address/data bus bit 2.
			SD1_DAT1	I/O	MFP3	SD/SDIO1 data line bit 1.
			SPIM_SS	I/O	MFP4	SPIM slave select pin.
			BPWM0_CH3	I/O	MFP12	BPWM0 channel 3 output/capture input.
	80	88	PG.12	I/O	MFP0	General purpose digital I/O pin.
			EBI_AD3	I/O	MFP2	EBI address/data bus bit 3.
			SD1_DAT0	I/O	MFP3	SD/SDIO1 data line bit 0.
			SPIM_CLK	I/O	MFP4	SPIM serial clock pin.
			BPWM0_CH2	I/O	MFP12	BPWM0 channel 2 output/capture input.
	81	89	PG.13	I/O	MFP0	General purpose digital I/O pin.
			EBI_AD4	I/O	MFP2	EBI address/data bus bit 4.
			SD1_CMD	I/O	MFP3	SD/SDIO1 command/response pin
			SPIM_MISO	I/O	MFP4	SPIM MISO (Master In, Slave Out) pin.
			BPWM0_CH1	I/O	MFP12	BPWM0 channel 1 output/capture input.
	82	90	PG.14	I/O	MFP0	General purpose digital I/O pin.
			EBI_AD5	I/O	MFP2	EBI address/data bus bit 5.
			SD1_CLK	O	MFP3	SD/SDIO1 clock output pin
			SPIM_MOSI	I/O	MFP4	SPIM MOSI (Master Out, Slave In) pin.
			BPWM0_CH0	I/O	MFP12	BPWM0 channel 0 output/capture input.
	83	91	PG.15	I/O	MFP0	General purpose digital I/O pin.
			SD1_nCD	I	MFP3	SD/SDIO1 card detect input pin
			CLKO	O	MFP14	Clock Out
			EADC0_ST	I	MFP15	EADC0 external trigger input.
		92	PD.3	I/O	MFP0	General purpose digital I/O pin.
			EBI_AD10	I/O	MFP2	EBI address/data bus bit 10.
			USCI0_CTL1	I/O	MFP3	USCI0 control 1 pin.
			SPI0_SS	I/O	MFP4	SPI0 slave select pin.
			UART3_nRTS	O	MFP5	UART3 request to Send output pin.
			USCI1_CTL0	I/O	MFP6	USCI1 control 0 pin.

64 Pin	128 Pin	144 Pin	Pin Name	Type	MFP	Description
			SC2_PWR	O	MFP7	Smart Card 2 power pin.
			SC1_nCD	I	MFP8	Smart Card 1 card detect pin.
			UART0_TXD	O	MFP9	UART0 data transmitter output pin.
		93	PD.2	I/O	MFP0	General purpose digital I/O pin.
			EBI_AD11	I/O	MFP2	EBI address/data bus bit 11.
			USCI0_DAT1	I/O	MFP3	USCI0 data 1 pin.
			SPI0_CLK	I/O	MFP4	SPI0 serial clock pin.
			UART3_nCTS	I	MFP5	UART3 clear to Send input pin.
			SC2_RST	O	MFP7	Smart Card 2 reset pin.
			UART0_RXD	I	MFP9	UART0 data receiver input pin.
		94	PD.1	I/O	MFP0	General purpose digital I/O pin.
			EBI_AD12	I/O	MFP2	EBI address/data bus bit 12.
			USCI0_DAT0	I/O	MFP3	USCI0 data 0 pin.
			SPI0_MISO	I/O	MFP4	SPI0 MISO (Master In, Slave Out) pin.
			UART3_TXD	O	MFP5	UART3 data transmitter output pin.
			I2C2_SCL	I/O	MFP6	I2C2 clock pin.
			SC2_DAT	I/O	MFP7	Smart Card 2 data pin.
		95	PD.0	I/O	MFP0	General purpose digital I/O pin.
			EBI_AD13	I/O	MFP2	EBI address/data bus bit 13.
			USCI0_CLK	I/O	MFP3	USCI0 clock pin.
			SPI0_MOSI	I/O	MFP4	SPI0 MOSI (Master Out, Slave In) pin.
			UART3_RXD	I	MFP5	UART3 data receiver input pin.
			I2C2_SDA	I/O	MFP6	I2C2 data input/output pin.
			SC2_CLK	O	MFP7	Smart Card 2 clock pin.
			TM2	I/O	MFP14	Timer2 event counter input/toggle output pin.
	84	96	PD.13	I/O	MFP0	General purpose digital I/O pin.
			EBI_AD10	I/O	MFP2	EBI address/data bus bit 10.
			SD0_nCD	I	MFP3	SD/SDIO0 card detect input pin
			SPI0_I2SMCLK	I/O	MFP4	SPI0 I2S master clock output pin
			SPI1_I2SMCLK	I/O	MFP5	SPI1 I2S master clock output pin
			SC2_nCD	I	MFP7	Smart Card 2 card detect pin.
	85	97	PA.12	I/O	MFP0	General purpose digital I/O pin.
			I2S0_BCLK	O	MFP2	I2S0 bit clock output pin.
			UART4_TXD	O	MFP3	UART4 data transmitter output pin.

64 Pin	128 Pin	144 Pin	Pin Name	Type	MFP	Description
			I2C1_SCL	I/O	MFP4	I2C1 clock pin.
			SPI2_SS	I/O	MFP5	SPI2 slave select pin.
			CAN0_TXD	O	MFP6	CAN0 bus transmitter output.
			SC2_PWR	O	MFP7	Smart Card 2 power pin.
			BPWM1_CH2	I/O	MFP11	BPWM1 channel 2 output/capture input.
			QE11_INDEX	I	MFP12	Quadrature encoder 1 index input
			USB_VBUS	P	MFP14	Power supply from USB host or HUB.
	86	98	PA.13	I/O	MFP0	General purpose digital I/O pin.
			I2S0_MCLK	O	MFP2	I2S0 master clock output pin.
			UART4_RXD	I	MFP3	UART4 data receiver input pin.
			I2C1_SDA	I/O	MFP4	I2C1 data input/output pin.
			SPI2_CLK	I/O	MFP5	SPI2 serial clock pin.
			CAN0_RXD	I	MFP6	CAN0 bus receiver input.
			SC2_RST	O	MFP7	Smart Card 2 reset pin.
			BPWM1_CH3	I/O	MFP11	BPWM1 channel 3 output/capture input.
			QE11_A	I	MFP12	Quadrature encoder 1 phase A input
			USB_D-	A	MFP14	USB differential signal D-.
	87	99	PA.14	I/O	MFP0	General purpose digital I/O pin.
			I2S0_DI	I	MFP2	I2S0 data input pin.
			UART0_TXD	O	MFP3	UART0 data transmitter output pin.
			SPI2_MISO	I/O	MFP5	SPI2 MISO (Master In, Slave Out) pin.
			I2C2_SCL	I/O	MFP6	I2C2 clock pin.
			SC2_DAT	I/O	MFP7	Smart Card 2 data pin.
			BPWM1_CH4	I/O	MFP11	BPWM1 channel 4 output/capture input.
			QE11_B	I	MFP12	Quadrature encoder 1 phase B input
			USB_D+	A	MFP14	USB differential signal D+.
	88	100	PA.15	I/O	MFP0	General purpose digital I/O pin.
			I2S0_DO	O	MFP2	I2S0 data output pin.
			UART0_RXD	I	MFP3	UART0 data receiver input pin.
			SPI2_MOSI	I/O	MFP5	SPI2 MOSI (Master Out, Slave In) pin.
			I2C2_SDA	I/O	MFP6	I2C2 data input/output pin.
			SC2_CLK	O	MFP7	Smart Card 2 clock pin.
			BPWM1_CH5	I/O	MFP11	BPWM1 channel 5 output/capture input.
			EPWM0_SYNC_IN	I	MFP12	EPWM0 counter synchronous trigger input pin.

64 Pin	128 Pin	144 Pin	Pin Name	Type	MFP	Description
			USB_OTG_ID	I	MFP14	USB_ identification.
41	89	101	HSUSB_VRES	A	MFP0	HSUSB module reference resistor
42	90	102	HSUSB_VDD33	P	MFP0	Power supply for HSUSB VDD33
43	91	103	HSUSB_VBUS	P	MFP0	HSUSB Power supply from USB host or HUB.
44	92	104	HSUSB_D-	A	MFP0	HSUSB differential signal D-.
45	93	105	HSUSB_VSS	P	MFP0	Ground pin for HSUSB.
46	94	106	HSUSB_D+	A	MFP0	HSUSB differential signal D+.
47	95	107	HSUSB_VDD12_CAP	A	MFP0	HSUSB Internal power regulator output 1.2V decoupling pin. Note: This pin needs to be connected with a 1uF capacitor.
48	96	108	HSUSB_ID	I	MFP0	HSUSB identification.
	97	109	PE.7	I/O	MFP0	General purpose digital I/O pin.
			SD0_CMD	I/O	MFP3	SD/SDIO0 command/response pin
			SPIM_D2	I/O	MFP4	SPIM data 2 pin for Quad Mode I/O.
			UART5_TXD	O	MFP8	UART5 data transmitter output pin.
			CAN1_TXD	O	MFP9	CAN1 bus transmitter output.
			QEI1_INDEX	I	MFP11	Quadrature encoder 1 index input
			EPWM0_CH0	I/O	MFP12	EPWM0 channel 0 output/capture input.
			BPWM0_CH5	I/O	MFP13	BPWM0 channel 5 output/capture input.
	98	110	PE.6	I/O	MFP0	General purpose digital I/O pin.
			SD0_CLK	O	MFP3	SD/SDIO0 clock output pin
			SPIM_D3	I/O	MFP4	SPIM data 3 pin for Quad Mode I/O.
			SPI3_I2SMCLK	I/O	MFP5	SPI3 I2S master clock output pin
			SC0_nCD	I	MFP6	Smart Card 0 card detect pin.
			USCI0_CTL0	I/O	MFP7	USCI0 control 0 pin.
			UART5_RXD	I	MFP8	UART5 data receiver input pin.
			CAN1_RXD	I	MFP9	CAN1 bus receiver input.
			QEI1_A	I	MFP11	Quadrature encoder 1 phase A input
			EPWM0_CH1	I/O	MFP12	EPWM0 channel 1 output/capture input.
			BPWM0_CH4	I/O	MFP13	BPWM0 channel 4 output/capture input.
	99	111	PE.5	I/O	MFP0	General purpose digital I/O pin.
			EBI_nRD	O	MFP2	EBI read enable output pin.
			SD0_DAT3	I/O	MFP3	SD/SDIO0 data line bit 3.
			SPIM_SS	I/O	MFP4	SPIM slave select pin.
			SPI3_SS	I/O	MFP5	SPI3 slave select pin.

64 Pin	128 Pin	144 Pin	Pin Name	Type	MFP	Description
			SC0_PWR	O	MFP6	Smart Card 0 power pin.
			USCI0_CTL1	I/O	MFP7	USCI0 control 1 pin.
			QE11_B	I	MFP11	Quadrature encoder 1 phase B input
			EPWM0_CH2	I/O	MFP12	EPWM0 channel 2 output/capture input.
			BPWM0_CH3	I/O	MFP13	BPWM0 channel 3 output/capture input.
	100	112	PE.4	I/O	MFP0	General purpose digital I/O pin.
			EBI_nWR	O	MFP2	EBI write enable output pin.
			SD0_DAT2	I/O	MFP3	SD/SDIO0 data line bit 2.
			SPIM_CLK	I/O	MFP4	SPIM serial clock pin.
			SPI3_CLK	I/O	MFP5	SPI3 serial clock pin.
			SC0_RST	O	MFP6	Smart Card 0 reset pin.
			USCI0_DAT1	I/O	MFP7	USCI0 data 1 pin.
			QE10_INDEX	I	MFP11	Quadrature encoder 0 index input
			EPWM0_CH3	I/O	MFP12	EPWM0 channel 3 output/capture input.
			BPWM0_CH2	I/O	MFP13	BPWM0 channel 2 output/capture input.
	101	113	PE.3	I/O	MFP0	General purpose digital I/O pin.
			EBI_MCLK	O	MFP2	EBI external clock output pin.
			SD0_DAT1	I/O	MFP3	SD/SDIO0 data line bit 1.
			SPIM_MISO	I/O	MFP4	SPIM MISO (Master In, Slave Out) pin.
			SPI3_MISO	I/O	MFP5	SPI3 MISO (Master In, Slave Out) pin.
			SC0_DAT	I/O	MFP6	Smart Card 0 data pin.
			USCI0_DAT0	I/O	MFP7	USCI0 data 0 pin.
			QE10_A	I	MFP11	Quadrature encoder 0 phase A input
			EPWM0_CH4	I/O	MFP12	EPWM0 channel 4 output/capture input.
			BPWM0_CH1	I/O	MFP13	BPWM0 channel 1 output/capture input.
	102	114	PE.2	I/O	MFP0	General purpose digital I/O pin.
			EBI_ALE	O	MFP2	EBI address latch enable output pin.
			SD0_DAT0	I/O	MFP3	SD/SDIO0 data line bit 0.
			SPIM_MOSI	I/O	MFP4	SPIM MOSI (Master Out, Slave In) pin.
			SPI3_MOSI	I/O	MFP5	SPI3 MOSI (Master Out, Slave In) pin.
			SC0_CLK	O	MFP6	Smart Card 0 clock pin.
			USCI0_CLK	I/O	MFP7	USCI0 clock pin.
			QE10_B	I	MFP11	Quadrature encoder 0 phase B input
			EPWM0_CH5	I/O	MFP12	EPWM0 channel 5 output/capture input.

64 Pin	128 Pin	144 Pin	Pin Name	Type	MFP	Description
			BPWM0_CH0	I/O	MFP13	BPWM0 channel 0 output/capture input.
	103	115	V _{SS}	P	MFP0	Ground pin for digital circuit.
	104	116	V _{DD}	P	MFP0	Power supply for I/O ports and LDO source for internal PLL and digital circuit.
	105	117	PE.1	I/O	MFP0	General purpose digital I/O pin.
			EBI_AD10	I/O	MFP2	EBI address/data bus bit 10.
			QSPI0_MISO0	I/O	MFP3	Quad SPI0 MISO0 (Master In, Slave Out) pin.
			SC2_DAT	I/O	MFP4	Smart Card 2 data pin.
			I2S0_BCLK	O	MFP5	I2S0 bit clock output pin.
			SPI1_MISO	I/O	MFP6	SPI1 MISO (Master In, Slave Out) pin.
			UART3_TXD	O	MFP7	UART3 data transmitter output pin.
			I2C1_SCL	I/O	MFP8	I2C1 clock pin.
			UART4_nCTS	I	MFP9	UART4 clear to Send input pin.
	106	118	PE.0	I/O	MFP0	General purpose digital I/O pin.
			EBI_AD11	I/O	MFP2	EBI address/data bus bit 11.
			QSPI0_MOSI0	I/O	MFP3	Quad SPI0 MOSI0 (Master Out, Slave In) pin.
			SC2_CLK	O	MFP4	Smart Card 2 clock pin.
			I2S0_MCLK	O	MFP5	I2S0 master clock output pin.
			SPI1_MOSI	I/O	MFP6	SPI1 MOSI (Master Out, Slave In) pin.
			UART3_RXD	I	MFP7	UART3 data receiver input pin.
			I2C1_SDA	I/O	MFP8	I2C1 data input/output pin.
			UART4_nRTS	O	MFP9	UART4 request to Send output pin.
	107	119	PH.8	I/O	MFP0	General purpose digital I/O pin.
			EBI_AD12	I/O	MFP2	EBI address/data bus bit 12.
			QSPI0_CLK	I/O	MFP3	Quad SPI0 serial clock pin.
			SC2_PWR	O	MFP4	Smart Card 2 power pin.
			I2S0_DI	I	MFP5	I2S0 data input pin.
			SPI1_CLK	I/O	MFP6	SPI1 serial clock pin.
			UART3_nRTS	O	MFP7	UART3 request to Send output pin.
			I2C1_SMBAL	O	MFP8	I2C1 SMBus SMBALTER pin
			I2C2_SCL	I/O	MFP9	I2C2 clock pin.
			UART1_TXD	O	MFP10	UART1 data transmitter output pin.
	108	120	PH.9	I/O	MFP0	General purpose digital I/O pin.
			EBI_AD13	I/O	MFP2	EBI address/data bus bit 13.

64 Pin	128 Pin	144 Pin	Pin Name	Type	MFP	Description
			QSPI0_SS	I/O	MFP3	Quad SPI0 slave select pin.
			SC2_RST	O	MFP4	Smart Card 2 reset pin.
			I2S0_DO	O	MFP5	I2S0 data output pin.
			SPI1_SS	I/O	MFP6	SPI1 slave select pin.
			UART3_nCTS	I	MFP7	UART3 clear to Send input pin.
			I2C1_SMBSUS	O	MFP8	I2C1 SMBus SMBSUS pin (PMBus CONTROL pin)
			I2C2_SDA	I/O	MFP9	I2C2 data input/output pin.
			UART1_RXD	I	MFP10	UART1 data receiver input pin.
	109	121	PH.10	I/O	MFP0	General purpose digital I/O pin.
			EBI_AD14	I/O	MFP2	EBI address/data bus bit 14.
			QSPI0_MISO1	I/O	MFP3	Quad SPI0 MISO1 (Master In, Slave Out) pin.
			SC2_nCD	I	MFP4	Smart Card 2 card detect pin.
			I2S0_LRCK	O	MFP5	I2S0 left right channel clock output pin.
			SPI1_I2SMCLK	I/O	MFP6	SPI1 I2S master clock output pin
			UART4_TXD	O	MFP7	UART4 data transmitter output pin.
			UART0_TXD	O	MFP8	UART0 data transmitter output pin.
	110	122	PH.11	I/O	MFP0	General purpose digital I/O pin.
			EBI_AD15	I/O	MFP2	EBI address/data bus bit 15.
			QSPI0_MOSI1	I/O	MFP3	Quad SPI0 MOSI1 (Master Out, Slave In) pin.
			UART4_RXD	I	MFP7	UART4 data receiver input pin.
			UART0_RXD	I	MFP8	UART0 data receiver input pin.
			EPWM0_CH5	I/O	MFP11	EPWM0 channel 5 output/capture input.
	111	123	PD.14	I/O	MFP0	General purpose digital I/O pin.
			EBI_nCS0	O	MFP2	EBI chip select 0 output pin.
			SPI3_I2SMCLK	I/O	MFP3	SPI3 I2S master clock output pin
			SC1_nCD	I	MFP4	Smart Card 1 card detect pin.
			EPWM0_CH4	I/O	MFP11	EPWM0 channel 4 output/capture input.
		124	PG.5	I/O	MFP0	General purpose digital I/O pin.
			EBI_nCS1	O	MFP2	EBI chip select 1 output pin.
			SPI3_SS	I/O	MFP3	SPI3 slave select pin.
			SC1_PWR	O	MFP4	Smart Card 1 power pin.
			EPWM0_CH3	I/O	MFP11	EPWM0 channel 3 output/capture input.
		125	PG.6	I/O	MFP0	General purpose digital I/O pin.
			EBI_nCS2	O	MFP2	EBI chip select 2 output pin.

64 Pin	128 Pin	144 Pin	Pin Name	Type	MFP	Description
			SPI3_CLK	I/O	MFP3	SPI3 serial clock pin.
			SC1_RST	O	MFP4	Smart Card 1 reset pin.
			EPWM0_CH2	I/O	MFP11	EPWM0 channel 2 output/capture input.
		126	PG.7	I/O	MFP0	General purpose digital I/O pin.
			EBI_nWRL	O	MFP2	EBI low byte write enable output pin.
			SPI3_MISO	I/O	MFP3	SPI3 MISO (Master In, Slave Out) pin.
			SC1_DAT	I/O	MFP4	Smart Card 1 data pin.
			EPWM0_CH1	I/O	MFP11	EPWM0 channel 1 output/capture input.
		127	PG.8	I/O	MFP0	General purpose digital I/O pin.
			EBI_nWRH	O	MFP2	EBI high byte write enable output pin
			SPI3_MOSI	I/O	MFP3	SPI3 MOSI (Master Out, Slave In) pin.
			SC1_CLK	O	MFP4	Smart Card 1 clock pin.
			EPWM0_CH0	I/O	MFP11	EPWM0 channel 0 output/capture input.
49	112	128	V _{SS}	P	MFP0	Ground pin for digital circuit.
50	113	129	LDO_CAP	A	MFP0	LDO output pin.
51	114	130	V _{DD}	P	MFP0	Power supply for I/O ports and LDO source for internal PLL and digital circuit.
52	115	131	PC.14	I/O	MFP0	General purpose digital I/O pin.
			EBI_AD11	I/O	MFP2	EBI address/data bus bit 11.
			SC1_nCD	I	MFP3	Smart Card 1 card detect pin.
			SPI0_I2SMCLK	I/O	MFP4	SPI0 I2S master clock output pin
			USCI0_CTL0	I/O	MFP5	USCI0 control 0 pin.
			QSPI0_CLK	I/O	MFP6	Quad SPI0 serial clock pin.
			EPWM0_SYNC_IN	I	MFP11	EPWM0 counter synchronous trigger input pin.
			TM1	I/O	MFP13	Timer1 event counter input/toggle output pin.
			USB_VBUS_ST	I	MFP14	USB external VBUS regulator status pin.
			HSUSB_VBUS_ST	I	MFP15	HSUSB external VBUS regulator status pin.
53	116	132	PB.15	I/O	MFP0	General purpose digital I/O pin.
			EADC0_CH15	A	MFP1	EADC0 channel 15 analog input.
			EBI_AD12	I/O	MFP2	EBI address/data bus bit 12.
			SC1_PWR	O	MFP3	Smart Card 1 power pin.
			SPI0_SS	I/O	MFP4	SPI0 slave select pin.
			USCI0_CTL1	I/O	MFP5	USCI0 control 1 pin.
			UART0_nCTS	I	MFP6	UART0 clear to Send input pin.

64 Pin	128 Pin	144 Pin	Pin Name	Type	MFP	Description
			UART3_TXD	O	MFP7	UART3 data transmitter output pin.
			I2C2_SMBAL	O	MFP8	I2C2 SMBus SMBALTER pin
			EPWM1_CH0	I/O	MFP11	EPWM1 channel 0 output/capture input.
			TM0_EXT	I/O	MFP13	Timer0 external capture input/toggle output pin.
			USB_VBUS_EN	O	MFP14	USB external VBUS regulator enable pin.
			HSUSB_VBUS_EN	O	MFP15	HSUSB external VBUS regulator enable pin.
54	117	133	PB.14	I/O	MFP0	General purpose digital I/O pin.
			EADC0_CH14	A	MFP1	EADC0 channel 14 analog input.
			EBI_AD13	I/O	MFP2	EBI address/data bus bit 13.
			SC1_RST	O	MFP3	Smart Card 1 reset pin.
			SPI0_CLK	I/O	MFP4	SPI0 serial clock pin.
			USCI0_DAT1	I/O	MFP5	USCI0 data 1 pin.
			UART0_nRTS	O	MFP6	UART0 request to Send output pin.
			UART3_RXD	I	MFP7	UART3 data receiver input pin.
			I2C2_SMBSUS	O	MFP8	I2C2 SMBus SMBSUS pin (PMBus CONTROL pin)
			EPWM1_CH1	I/O	MFP11	EPWM1 channel 1 output/capture input.
			TM1_EXT	I/O	MFP13	Timer1 external capture input/toggle output pin.
			CLKO	O	MFP14	Clock Out
55	118	134	PB.13	I/O	MFP0	General purpose digital I/O pin.
			EADC0_CH13	A	MFP1	EADC0 channel 13 analog input.
			DAC1_OUT	A	MFP1	DAC1 channel analog output.
			ACMP0_P3	A	MFP1	Analog comparator 0 positive input 3 pin.
			ACMP1_P3	A	MFP1	Analog comparator 1 positive input 3 pin.
			EBI_AD14	I/O	MFP2	EBI address/data bus bit 14.
			SC1_DAT	I/O	MFP3	Smart Card 1 data pin.
			SPI0_MISO	I/O	MFP4	SPI0 MISO (Master In, Slave Out) pin.
			USCI0_DAT0	I/O	MFP5	USCI0 data 0 pin.
			UART0_TXD	O	MFP6	UART0 data transmitter output pin.
			UART3_nRTS	O	MFP7	UART3 request to Send output pin.
			I2C2_SCL	I/O	MFP8	I2C2 clock pin.
			EPWM1_CH2	I/O	MFP11	EPWM1 channel 2 output/capture input.
			TM2_EXT	I/O	MFP13	Timer2 external capture input/toggle output pin.
56	119	135	PB.12	I/O	MFP0	General purpose digital I/O pin.
			EADC0_CH12	A	MFP1	EADC0 channel 12 analog input.

64 Pin	128 Pin	144 Pin	Pin Name	Type	MFP	Description
			DAC0_OUT	A	MFP1	DAC0 channel analog output.
			ACMP0_P2	A	MFP1	Analog comparator 0 positive input 2 pin.
			ACMP1_P2	A	MFP1	Analog comparator 1 positive input 2 pin.
			EBI_AD15	I/O	MFP2	EBI address/data bus bit 15.
			SC1_CLK	O	MFP3	Smart Card 1 clock pin.
			SPI0_MOSI	I/O	MFP4	SPI0 MOSI (Master Out, Slave In) pin.
			USCI0_CLK	I/O	MFP5	USCI0 clock pin.
			UART0_RXD	I	MFP6	UART0 data receiver input pin.
			UART3_nCTS	I	MFP7	UART3 clear to Send input pin.
			I2C2_SDA	I/O	MFP8	I2C2 data input/output pin.
			SD0_nCD	I	MFP9	SD/SDIO0 card detect input pin
			EPWM1_CH3	I/O	MFP11	EPWM1 channel 3 output/capture input.
			TM3_EXT	I/O	MFP13	Timer3 external capture input/toggle output pin.
57	120	136	AV _{DD}	P	MFP0	Power supply for internal analog circuit.
58	121	137	V _{REF}	A	MFP0	ADC reference voltage input. Note: This pin needs to be connected with a 1uF capacitor.
59	122	138	AV _{SS}	P	MFP0	Ground pin for analog circuit.
60	123	139	PB.11	I/O	MFP0	General purpose digital I/O pin.
			EADC0_CH11	A	MFP1	EADC0 channel 11 analog input.
			EBI_ADR16	O	MFP2	EBI address bus bit 16.
			EMAC_RMII_MDC	O	MFP3	EMAC RMII PHY Management Clock output pin.
			UART0_nCTS	I	MFP5	UART0 clear to Send input pin.
			UART4_TXD	O	MFP6	UART4 data transmitter output pin.
			I2C1_SCL	I/O	MFP7	I2C1 clock pin.
			CAN0_TXD	O	MFP8	CAN0 bus transmitter output.
			SPI0_I2SMCLK	I/O	MFP9	SPI0 I2S master clock output pin
			BPWM1_CH0	I/O	MFP10	BPWM1 channel 0 output/capture input.
			SPI3_CLK	I/O	MFP11	SPI3 serial clock pin.
			HSUSB_VBUS_ST	I	MFP14	HSUSB external VBUS regulator status pin.
61	124	140	PB.10	I/O	MFP0	General purpose digital I/O pin.
			EADC0_CH10	A	MFP1	EADC0 channel 10 analog input.
			EBI_ADR17	O	MFP2	EBI address bus bit 17.
			EMAC_RMII_MDIO	I/O	MFP3	EMAC RMII PHY Management Data pin.
			USCI1_CTL0	I/O	MFP4	USCI1 control 0 pin.

64 Pin	128 Pin	144 Pin	Pin Name	Type	MFP	Description
			UART0_nRTS	O	MFP5	UART0 request to Send output pin.
			UART4_RXD	I	MFP6	UART4 data receiver input pin.
			I2C1_SDA	I/O	MFP7	I2C1 data input/output pin.
			CAN0_RXD	I	MFP8	CAN0 bus receiver input.
			BPWM1_CH1	I/O	MFP10	BPWM1 channel 1 output/capture input.
			SPI3_SS	I/O	MFP11	SPI3 slave select pin.
			HSUSB_VBUS_EN	O	MFP14	HSUSB external VBUS regulator enable pin.
62	125	141	PB.9	I/O	MFP0	General purpose digital I/O pin.
			EADC0_CH9	A	MFP1	EADC0 channel 9 analog input.
			EBI_ADR18	O	MFP2	EBI address bus bit 18.
			EMAC_RMII_TXD0	O	MFP3	EMAC RMII Transmit Data bus bit 0.
			USC11_CTL1	I/O	MFP4	USC11 control 1 pin.
			UART0_TXD	O	MFP5	UART0 data transmitter output pin.
			UART1_nCTS	I	MFP6	UART1 clear to Send input pin.
			I2C1_SMBAL	O	MFP7	I2C1 SMBus SMBALTER pin
			BPWM1_CH2	I/O	MFP10	BPWM1 channel 2 output/capture input.
			SPI3_MISO	I/O	MFP11	SPI3 MISO (Master In, Slave Out) pin.
			INT7	I	MFP13	External interrupt 7 input pin.
63	126	142	PB.8	I/O	MFP0	General purpose digital I/O pin.
			EADC0_CH8	A	MFP1	EADC0 channel 8 analog input.
			EBI_ADR19	O	MFP2	EBI address bus bit 19.
			EMAC_RMII_TXD1	O	MFP3	EMAC RMII Transmit Data bus bit 1.
			USC11_CLK	I/O	MFP4	USC11 clock pin.
			UART0_RXD	I	MFP5	UART0 data receiver input pin.
			UART1_nRTS	O	MFP6	UART1 request to Send output pin.
			I2C1_SMBSUS	O	MFP7	I2C1 SMBus SMBSUS pin (PMBus CONTROL pin)
			BPWM1_CH3	I/O	MFP10	BPWM1 channel 3 output/capture input.
			SPI3_MOSI	I/O	MFP11	SPI3 MOSI (Master Out, Slave In) pin.
			INT6	I	MFP13	External interrupt 6 input pin.
64	127	143	PB.7	I/O	MFP0	General purpose digital I/O pin.
			EADC0_CH7	A	MFP1	EADC0 channel 7 analog input.
			EBI_nWRL	O	MFP2	EBI low byte write enable output pin.
			EMAC_RMII_TXEN	O	MFP3	EMAC RMII Transmit Enable output pin.
			USC11_DAT0	I/O	MFP4	USC11 data 0 pin.

64 Pin	128 Pin	144 Pin	Pin Name	Type	MFP	Description
			CAN1_TXD	O	MFP5	CAN1 bus transmitter output.
			UART1_TXD	O	MFP6	UART1 data transmitter output pin.
			SD1_CMD	I/O	MFP7	SD/SDIO1 command/response pin
			EBI_nCS0	O	MFP8	EBI chip select 0 output pin.
			BPWM1_CH4	I/O	MFP10	BPWM1 channel 4 output/capture input.
			EPWM1_BRAKE0	I	MFP11	EPWM1 Brake 0 input pin.
			EPWM1_CH4	I/O	MFP12	EPWM1 channel 4 output/capture input.
			INT5	I	MFP13	External interrupt 5 input pin.
			USB_VBUS_ST	I	MFP14	USB external VBUS regulator status pin.
			ACMP0_O	O	MFP15	Analog comparator 0 output pin.
1	128	144	PB.6	I/O	MFP0	General purpose digital I/O pin.
			EADC0_CH6	A	MFP1	EADC0 channel 6 analog input.
			EBI_nWRH	O	MFP2	EBI high byte write enable output pin
			EMAC_PPS	O	MFP3	EMAC Pulse Per Second output pin.
			USCI1_DAT1	I/O	MFP4	USCI1 data 1 pin.
			CAN1_RXD	I	MFP5	CAN1 bus receiver input.
			UART1_RXD	I	MFP6	UART1 data receiver input pin.
			SD1_CLK	O	MFP7	SD/SDIO1 clock output pin
			EBI_nCS1	O	MFP8	EBI chip select 1 output pin.
			BPWM1_CH5	I/O	MFP10	BPWM1 channel 5 output/capture input.
			EPWM1_BRAKE1	I	MFP11	EPWM1 Brake 1 input pin.
			EPWM1_CH5	I/O	MFP12	EPWM1 channel 5 output/capture input.
			INT4	I	MFP13	External interrupt 4 input pin.
			USB_VBUS_EN	O	MFP14	USB external VBUS regulator enable pin.
			ACMP1_O	O	MFP15	Analog comparator 1 output pin.

4.2.7 M480 Multi-function Summary Table

Group	Pin Name	GPIO	MFP	Type	Description
ACMP0	ACMP0_N	PB.3	MFP1	A	Analog comparator 0 negative input pin.
	ACMP0_O	PC.12	MFP14	O	Analog comparator 0 output pin.
		PC.1	MFP14	O	
		PB.7	MFP15	O	
	ACMP0_P0	PA.11	MFP1	A	Analog comparator 0 positive input 0 pin.
	ACMP0_P1	PB.2	MFP1	A	Analog comparator 0 positive input 1 pin.
	ACMP0_P2	PB.12	MFP1	A	Analog comparator 0 positive input 2 pin.
	ACMP0_P3	PB.13	MFP1	A	Analog comparator 0 positive input 3 pin.
ACMP0_WLAT	PA.7	MFP13	I	Analog comparator 0 window latch input pin	
ACMP1	ACMP1_N	PB.5	MFP1	A	Analog comparator 1 negative input pin.
	ACMP1_O	PC.11	MFP14	O	Analog comparator 1 output pin.
		PC.0	MFP14	O	
		PB.6	MFP15	O	
	ACMP1_P0	PA.10	MFP1	A	Analog comparator 1 positive input 0 pin.
	ACMP1_P1	PB.4	MFP1	A	Analog comparator 1 positive input 1 pin.
	ACMP1_P2	PB.12	MFP1	A	Analog comparator 1 positive input 2 pin.
	ACMP1_P3	PB.13	MFP1	A	Analog comparator 1 positive input 3 pin.
ACMP1_WLAT	PA.6	MFP13	I	Analog comparator 1 window latch input pin	
BPWM0	BPWM0_CH0	PA.11	MFP9	I/O	BPWM0 channel 0 output/capture input.
		PA.0	MFP12	I/O	
		PG.14	MFP12	I/O	
		PE.2	MFP13	I/O	
	BPWM0_CH1	PA.10	MFP9	I/O	BPWM0 channel 1 output/capture input.
		PA.1	MFP12	I/O	
		PG.13	MFP12	I/O	
		PE.3	MFP13	I/O	
	BPWM0_CH2	PA.9	MFP9	I/O	BPWM0 channel 2 output/capture input.
		PA.2	MFP12	I/O	
		PG.12	MFP12	I/O	
		PE.4	MFP13	I/O	
	BPWM0_CH3	PA.8	MFP9	I/O	BPWM0 channel 3 output/capture input.
		PA.3	MFP12	I/O	
		PG.11	MFP12	I/O	

Group	Pin Name	GPIO	MFP	Type	Description
BPWM0	BPWM0_CH4	PE.5	MFP13	I/O	BPWM0 channel 4 output/capture input.
		PC.13	MFP9	I/O	
		PF.5	MFP8	I/O	
		PA.4	MFP12	I/O	
		PG.10	MFP12	I/O	
	PE.6	MFP13	I/O		
	BPWM0_CH5	PD.12	MFP9	I/O	BPWM0 channel 5 output/capture input.
		PF.4	MFP8	I/O	
		PA.5	MFP12	I/O	
		PG.9	MFP12	I/O	
PE.7		MFP13	I/O		
BPWM1	BPWM1_CH0	PF.3	MFP11	I/O	BPWM1 channel 0 output/capture input.
		PC.7	MFP12	I/O	
		PF.0	MFP12	I/O	
		PB.11	MFP10	I/O	
	BPWM1_CH1	PF.2	MFP11	I/O	BPWM1 channel 1 output/capture input.
		PC.6	MFP12	I/O	
		PF.1	MFP12	I/O	
		PB.10	MFP10	I/O	
	BPWM1_CH2	PA.7	MFP12	I/O	BPWM1 channel 2 output/capture input.
		PA.12	MFP11	I/O	
		PB.9	MFP10	I/O	
	BPWM1_CH3	PA.6	MFP12	I/O	BPWM1 channel 3 output/capture input.
		PA.13	MFP11	I/O	
		PB.8	MFP10	I/O	
	BPWM1_CH4	PC.8	MFP12	I/O	BPWM1 channel 4 output/capture input.
		PA.14	MFP11	I/O	
		PB.7	MFP10	I/O	
	BPWM1_CH5	PE.13	MFP12	I/O	BPWM1 channel 5 output/capture input.
		PA.15	MFP11	I/O	
		PB.6	MFP10	I/O	
CAN0	CAN0_RXD	PD.10	MFP4	I	CAN0 bus receiver input.
		PA.4	MFP10	I	
		PE.15	MFP4	I	

Group	Pin Name	GPIO	MFP	Type	Description		
CAN0		PC.4	MFP10	I	CAN0 bus transmitter output.		
		PA.13	MFP6	I			
		PB.10	MFP8	I			
	CAN0_TXD	PD.11	MFP4	O			
		PA.5	MFP10	O			
		PE.14	MFP4	O			
		PC.5	MFP10	O			
		PA.12	MFP6	O			
		PB.11	MFP8	O			
	CAN1	CAN1_RXD	PC.9	MFP9		I	CAN1 bus receiver input.
			PD.12	MFP5		I	
			PG.1	MFP7		I	
PC.2			MFP10	I			
PE.6			MFP9	I			
PB.6			MFP5	I			
CAN1_TXD		PC.10	MFP9	O	CAN1 bus transmitter output.		
		PC.13	MFP5	O			
		PG.0	MFP7	O			
		PC.3	MFP10	O			
		PE.7	MFP9	O			
		PB.7	MFP5	O			
CLKO	CLKO	PC.13	MFP13	O	Clock Out		
		PD.12	MFP13	O			
		PG.15	MFP14	O			
		PB.14	MFP14	O			
DAC0	DAC0_OUT	PB.12	MFP1	A	DAC0 channel analog output.		
	DAC0_ST	PA.10	MFP14	I	DAC0 external trigger input.		
		PA.0	MFP15	I			
DAC1	DAC1_OUT	PB.13	MFP1	A	DAC1 channel analog output.		
	DAC1_ST	PA.11	MFP14	I	DAC1 external trigger input.		
		PA.1	MFP15	I			
EADC0	EADC0_CH0	PB.0	MFP1	A	EADC0 channel 0 analog input.		
	EADC0_CH1	PB.1	MFP1	A	EADC0 channel 1 analog input.		
	EADC0_CH2	PB.2	MFP1	A	EADC0 channel 2 analog input.		

Group	Pin Name	GPIO	MFP	Type	Description
	EADC0_CH3	PB.3	MFP1	A	EADC0 channel 3 analog input.
	EADC0_CH4	PB.4	MFP1	A	EADC0 channel 4 analog input.
	EADC0_CH5	PB.5	MFP1	A	EADC0 channel 5 analog input.
	EADC0_CH6	PB.6	MFP1	A	EADC0 channel 6 analog input.
	EADC0_CH7	PB.7	MFP1	A	EADC0 channel 7 analog input.
	EADC0_CH8	PB.8	MFP1	A	EADC0 channel 8 analog input.
	EADC0_CH9	PB.9	MFP1	A	EADC0 channel 9 analog input.
	EADC0_CH10	PB.10	MFP1	A	EADC0 channel 10 analog input.
	EADC0_CH11	PB.11	MFP1	A	EADC0 channel 11 analog input.
	EADC0_CH12	PB.12	MFP1	A	EADC0 channel 12 analog input.
	EADC0_CH13	PB.13	MFP1	A	EADC0 channel 13 analog input.
	EADC0_CH14	PB.14	MFP1	A	EADC0 channel 14 analog input.
	EADC0_CH15	PB.15	MFP1	A	EADC0 channel 15 analog input.
	EADC0_ST	PC.13	MFP14	I	EADC0 external trigger input.
		PD.12	MFP14	I	
PF.5		MFP11	I		
PG.15		MFP15	I		
EBI	EBI_AD0	PC.0	MFP2	I/O	EBI address/data bus bit 0.
		PG.9	MFP2	I/O	
	EBI_AD1	PC.1	MFP2	I/O	EBI address/data bus bit 1.
		PG.10	MFP2	I/O	
	EBI_AD2	PC.2	MFP2	I/O	EBI address/data bus bit 2.
		PG.11	MFP2	I/O	
	EBI_AD3	PC.3	MFP2	I/O	EBI address/data bus bit 3.
		PG.12	MFP2	I/O	
	EBI_AD4	PC.4	MFP2	I/O	EBI address/data bus bit 4.
		PG.13	MFP2	I/O	
	EBI_AD5	PC.5	MFP2	I/O	EBI address/data bus bit 5.
		PG.14	MFP2	I/O	
	EBI_AD6	PA.6	MFP2	I/O	EBI address/data bus bit 6.
		PD.8	MFP2	I/O	
	EBI_AD7	PA.7	MFP2	I/O	EBI address/data bus bit 7.
		PD.9	MFP2	I/O	
EBI_AD8	PC.6	MFP2	I/O	EBI address/data bus bit 8.	

Group	Pin Name	GPIO	MFP	Type	Description
		PE.14	MFP2	I/O	
	EBI_AD9	PC.7	MFP2	I/O	EBI address/data bus bit 9.
		PE.15	MFP2	I/O	
	EBI_AD10	PD.3	MFP2	I/O	EBI address/data bus bit 10.
		PD.13	MFP2	I/O	
		PE.1	MFP2	I/O	
	EBI_AD11	PD.2	MFP2	I/O	EBI address/data bus bit 11.
		PE.0	MFP2	I/O	
		PC.14	MFP2	I/O	
	EBI_AD12	PD.1	MFP2	I/O	EBI address/data bus bit 12.
		PH.8	MFP2	I/O	
		PB.15	MFP2	I/O	
	EBI_AD13	PD.0	MFP2	I/O	EBI address/data bus bit 13.
		PH.9	MFP2	I/O	
		PB.14	MFP2	I/O	
	EBI_AD14	PH.10	MFP2	I/O	EBI address/data bus bit 14.
		PB.13	MFP2	I/O	
	EBI_AD15	PH.11	MFP2	I/O	EBI address/data bus bit 15.
		PB.12	MFP2	I/O	
	EBI_ADR0	PB.5	MFP2	O	EBI address bus bit 0.
		PH.7	MFP2	O	
	EBI_ADR1	PB.4	MFP2	O	EBI address bus bit 1.
		PH.6	MFP2	O	
	EBI_ADR2	PB.3	MFP2	O	EBI address bus bit 2.
		PH.5	MFP2	O	
	EBI_ADR3	PB.2	MFP2	O	EBI address bus bit 3.
		PH.4	MFP2	O	
	EBI_ADR4	PC.12	MFP2	O	EBI address bus bit 4.
		PH.3	MFP2	O	
	EBI_ADR5	PC.11	MFP2	O	EBI address bus bit 5.
		PH.2	MFP2	O	
	EBI_ADR6	PC.10	MFP2	O	EBI address bus bit 6.
		PH.1	MFP2	O	
	EBI_ADR7	PC.9	MFP2	O	EBI address bus bit 7.

Group	Pin Name	GPIO	MFP	Type	Description
		PH.0	MFP2	O	
	EBI_ADR8	PB.1	MFP2	O	EBI address bus bit 8.
		PG.0	MFP2	O	
	EBI_ADR9	PB.0	MFP2	O	EBI address bus bit 9.
		PG.1	MFP2	O	
	EBI_ADR10	PC.13	MFP2	O	EBI address bus bit 10.
		PE.8	MFP2	O	
	EBI_ADR11	PG.2	MFP2	O	EBI address bus bit 11.
		PE.9	MFP2	O	
	EBI_ADR12	PG.3	MFP2	O	EBI address bus bit 12.
		PE.10	MFP2	O	
	EBI_ADR13	PG.4	MFP2	O	EBI address bus bit 13.
		PE.11	MFP2	O	
	EBI_ADR14	PF.11	MFP2	O	EBI address bus bit 14.
		PE.12	MFP2	O	
	EBI_ADR15	PF.10	MFP2	O	EBI address bus bit 15.
		PE.13	MFP2	O	
	EBI_ADR16	PF.9	MFP2	O	EBI address bus bit 16.
		PC.8	MFP2	O	
		PB.11	MFP2	O	
	EBI_ADR17	PF.8	MFP2	O	EBI address bus bit 17.
		PB.10	MFP2	O	
	EBI_ADR18	PF.7	MFP2	O	EBI address bus bit 18.
		PB.9	MFP2	O	
	EBI_ADR19	PF.6	MFP2	O	EBI address bus bit 19.
		PB.8	MFP2	O	
	EBI_ALE	PA.8	MFP2	O	EBI address latch enable output pin.
		PE.2	MFP2	O	
	EBI_MCLK	PA.9	MFP2	O	EBI external clock output pin.
		PE.3	MFP2	O	
	EBI_nCS0	PD.12	MFP2	O	EBI chip select 0 output pin.
		PF.6	MFP7	O	
		PF.3	MFP2	O	
		PD.14	MFP2	O	

Group	Pin Name	GPIO	MFP	Type	Description	
	EBI_nCS1	PB.7	MFP8	O	EBI chip select 1 output pin.	
		PD.11	MFP2	O		
			PF.2	MFP2		O
			PG.5	MFP2		O
			PB.6	MFP8		O
	EBI_nCS2	PD.10	MFP2	O	EBI chip select 2 output pin.	
		PG.6	MFP2	O		
	EBI_nRD	PA.11	MFP2	O	EBI read enable output pin.	
		PE.5	MFP2	O		
	EBI_nWR	PA.10	MFP2	O	EBI write enable output pin.	
		PE.4	MFP2	O		
	EBI_nWRH	PG.8	MFP2	O	EBI high byte write enable output pin	
		PB.6	MFP2	O		
	EBI_nWRL	PG.7	MFP2	O	EBI low byte write enable output pin.	
PB.7		MFP2	O			
ECAP0	ECAP0_IC0	PA.10	MFP11	I	Enhanced capture unit 0 input 0 pin.	
		PE.8	MFP12	I		
	ECAP0_IC1	PA.9	MFP11	I	Enhanced capture unit 0 input 1 pin.	
		PE.9	MFP12	I		
	ECAP0_IC2	PA.8	MFP11	I	Enhanced capture unit 0 input 2 pin.	
		PE.10	MFP12	I		
ECAP1	ECAP1_IC0	PC.10	MFP11	I	Enhanced capture unit 1 input 0 pin.	
		PE.13	MFP13	I		
	ECAP1_IC1	PC.11	MFP11	I	Enhanced capture unit 1 input 1 pin.	
		PE.12	MFP13	I		
	ECAP1_IC2	PC.12	MFP11	I	Enhanced capture unit 1 input 2 pin.	
		PE.11	MFP13	I		
EMAC	EMAC_RMII_MDC	PE.8	MFP3	O	EMAC RMII PHY Management Clock output pin.	
		PB.11	MFP3	O		
	EMAC_RMII_MDIO	PE.9	MFP3	I/O	EMAC RMII PHY Management Data pin.	
		PB.10	MFP3	I/O		
	EMAC_RMII_RXD0	PB.4	MFP4	I	EMAC RMII Receive Data bus bit 0.	
		PC.7	MFP3	I		
	EMAC_RMII_RXD1	PB.3	MFP4	I	EMAC RMII Receive Data bus bit 1.	

Group	Pin Name	GPIO	MFP	Type	Description
		PC.6	MFP3	I	
	EMAC_RMII_CRSDV	PB.2	MFP4	I	EMAC RMII Carrier Sense/Receive Data input pin.
		PA.7	MFP3	I	
	EMAC_RMII_RXERR	PB.1	MFP4	I	EMAC RMII Receive Data Error input pin.
		PA.6	MFP3	I	
	EMAC_RMII_TXD0	PE.10	MFP3	O	EMAC RMII Transmit Data bus bit 0.
		PB.9	MFP3	O	
	EMAC_RMII_TXD1	PE.11	MFP3	O	EMAC RMII Transmit Data bus bit 1.
		PB.8	MFP3	O	
	EMAC_RMII_TXEN	PE.12	MFP3	O	EMAC RMII Transmit Enable output pin.
		PB.7	MFP3	O	
	EMAC_PPS	PE.13	MFP3	O	EMAC Pulse Per Second output pin.
		PB.6	MFP3	O	
	EMAC_RMII_REFCLK	PB.5	MFP4	I	EMAC RMII reference clock input pin.
PC.8		MFP3	I		
EPWM0	EPWM0_BRAKE0	PB.1	MFP13	I	EPWM0 Brake 0 input pin.
		PE.8	MFP11	I	
	EPWM0_BRAKE1	PB.0	MFP13	I	EPWM0 Brake 1 input pin.
		PE.9	MFP11	I	
	EPWM0_CH0	PB.5	MFP11	I/O	EPWM0 channel 0 output/capture input.
		PE.8	MFP10	I/O	
		PA.5	MFP13	I/O	
		PE.7	MFP12	I/O	
		PG.8	MFP11	I/O	
	EPWM0_CH1	PB.4	MFP11	I/O	EPWM0 channel 1 output/capture input.
		PE.9	MFP10	I/O	
		PA.4	MFP13	I/O	
		PE.6	MFP12	I/O	
		PG.7	MFP11	I/O	
	EPWM0_CH2	PB.3	MFP11	I/O	EPWM0 channel 2 output/capture input.
PE.10		MFP10	I/O		
PA.3		MFP13	I/O		
PE.5		MFP12	I/O		
PG.6		MFP11	I/O		

Group	Pin Name	GPIO	MFP	Type	Description
	EPWM0_CH3	PB.2	MFP11	I/O	EPWM0 channel 3 output/capture input.
		PE.11	MFP10	I/O	
		PA.2	MFP13	I/O	
		PE.4	MFP12	I/O	
		PG.5	MFP11	I/O	
	EPWM0_CH4	PB.1	MFP11	I/O	EPWM0 channel 4 output/capture input.
		PE.12	MFP10	I/O	
		PA.1	MFP13	I/O	
		PE.3	MFP12	I/O	
		PD.14	MFP11	I/O	
	EPWM0_CH5	PB.0	MFP11	I/O	EPWM0 channel 5 output/capture input.
		PE.13	MFP10	I/O	
		PA.0	MFP13	I/O	
		PE.2	MFP12	I/O	
		PH.11	MFP11	I/O	
	EPWM0_SYNC_IN	PA.15	MFP12	I	EPWM0 counter synchronous trigger input pin.
		PC.14	MFP11	I	
EPWM0_SYNC_OUT	PA.11	MFP10	O	EPWM0 counter synchronous trigger output pin.	
	PF.5	MFP9	O		
EPWM1	EPWM1_BRAKE0	PE.10	MFP11	I	EPWM1 Brake 0 input pin.
		PB.7	MFP11	I	
	EPWM1_BRAKE1	PE.11	MFP11	I	EPWM1 Brake 1 input pin.
		PB.6	MFP11	I	
	EPWM1_CH0	PC.12	MFP12	I/O	EPWM1 channel 0 output/capture input.
		PE.13	MFP11	I/O	
		PC.5	MFP12	I/O	
		PB.15	MFP11	I/O	
	EPWM1_CH1	PC.11	MFP12	I/O	EPWM1 channel 1 output/capture input.
		PC.8	MFP11	I/O	
		PC.4	MFP12	I/O	
		PB.14	MFP11	I/O	
	EPWM1_CH2	PC.10	MFP12	I/O	EPWM1 channel 2 output/capture input.
		PC.7	MFP11	I/O	
PC.3		MFP12	I/O		

Group	Pin Name	GPIO	MFP	Type	Description	
	EPWM1_CH3	PB.13	MFP11	I/O	EPWM1 channel 3 output/capture input.	
		PC.9	MFP12	I/O		
		PC.6	MFP11	I/O		
		PC.2	MFP12	I/O		
		PB.12	MFP11	I/O		
	EPWM1_CH4	PB.1	MFP12	I/O	EPWM1 channel 4 output/capture input.	
		PA.7	MFP11	I/O		
		PC.1	MFP12	I/O		
		PB.7	MFP12	I/O		
	EPWM1_CH5	PB.0	MFP12	I/O	EPWM1 channel 5 output/capture input.	
		PA.6	MFP11	I/O		
		PC.0	MFP12	I/O		
		PB.6	MFP12	I/O		
	HSUSB	HSUSB_VBUS_EN	PB.15	MFP15	O	HSUSB external VBUS regulator enable pin.
			PB.10	MFP14	O	
HSUSB_VBUS_ST		PC.14	MFP15	I	HSUSB external VBUS regulator status pin.	
		PB.11	MFP14	I		
I2C0	I2C0_SCL	PB.5	MFP6	I/O	I2C0 clock pin.	
		PC.12	MFP4	I/O		
		PG.0	MFP4	I/O		
		PH.2	MFP6	I/O		
		PF.3	MFP4	I/O		
		PE.13	MFP4	I/O		
		PA.5	MFP9	I/O		
		PC.1	MFP9	I/O		
	PD.7	MFP4	I/O			
	I2C0_SDA	PB.4	MFP6	I/O	I2C0 data input/output pin.	
		PC.11	MFP4	I/O		
		PG.1	MFP4	I/O		
		PH.3	MFP6	I/O		
		PF.2	MFP4	I/O		
		PC.8	MFP4	I/O		
PA.4		MFP9	I/O			
PC.0		MFP9	I/O			

Group	Pin Name	GPIO	MFP	Type	Description	
	I2C0_SMBAL	PD.6	MFP4	I/O	I2C0 SMBus SMBALTER pin	
		PG.2	MFP4	O		
		PC.3	MFP9	O		
	I2C0_SMBSUS	PG.3	MFP4	O	I2C0 SMBus SMBSUS pin (PMBus CONTROL pin)	
		PC.2	MFP9	O		
	I2C1	I2C1_SCL	PB.1	MFP9	I/O	I2C1 clock pin.
PG.2			MFP5	I/O		
PA.7			MFP8	I/O		
PA.3			MFP9	I/O		
PF.0			MFP3	I/O		
PC.5			MFP9	I/O		
PD.5			MFP4	I/O		
PA.12			MFP4	I/O		
PE.1			MFP8	I/O		
PB.11			MFP7	I/O		
I2C1_SDA		PB.0	MFP9	I/O	I2C1 data input/output pin.	
		PG.3	MFP5	I/O		
		PA.6	MFP8	I/O		
		PA.2	MFP9	I/O		
		PF.1	MFP3	I/O		
		PC.4	MFP9	I/O		
		PD.4	MFP4	I/O		
		PA.13	MFP4	I/O		
		PE.0	MFP8	I/O		
		PB.10	MFP7	I/O		
I2C1_SMBAL		PG.0	MFP5	O	I2C1 SMBus SMBALTER pin	
		PC.7	MFP8	O		
		PH.8	MFP8	O		
		PB.9	MFP7	O		
I2C1_SMBSUS		PG.1	MFP5	O	I2C1 SMBus SMBSUS pin (PMBus CONTROL pin)	
		PC.6	MFP8	O		
		PH.9	MFP8	O		
		PB.8	MFP7	O		
I2C2		I2C2_SCL	PA.11	MFP7	I/O	I2C2 clock pin.

Group	Pin Name	GPIO	MFP	Type	Description
		PA.1	MFP9	I/O	
		PD.9	MFP3	I/O	
		PD.1	MFP6	I/O	
		PA.14	MFP6	I/O	
		PH.8	MFP9	I/O	
		PB.13	MFP8	I/O	
	I2C2_SDA	PA.10	MFP7	I/O	I2C2 data input/output pin.
		PA.0	MFP9	I/O	
		PD.8	MFP3	I/O	
		PD.0	MFP6	I/O	
		PA.15	MFP6	I/O	
		PH.9	MFP9	I/O	
		PB.12	MFP8	I/O	
	I2C2_SMBAL	PB.15	MFP8	O	I2C2 SMBus SMBALTER pin
I2C2_SMBSUS	PB.14	MFP8	O	I2C2 SMBus SMBSUS pin (PMBus CONTROL pin)	
I2S0	I2S0_BCLK	PB.5	MFP10	O	I2S0 bit clock output pin.
		PF.10	MFP4	O	
		PE.8	MFP4	O	
		PC.4	MFP6	O	
		PA.12	MFP2	O	
		PE.1	MFP5	O	
	I2S0_DI	PB.3	MFP10	I	I2S0 data input pin.
		PF.8	MFP4	I	
		PE.10	MFP4	I	
		PC.2	MFP6	I	
		PA.14	MFP2	I	
		PH.8	MFP5	I	
	I2S0_DO	PB.2	MFP10	O	I2S0 data output pin.
		PF.7	MFP4	O	
		PE.11	MFP4	O	
		PC.1	MFP6	O	
		PA.15	MFP2	O	
		PH.9	MFP5	O	
	I2S0_LRCK	PB.1	MFP10	O	I2S0 left right channel clock output pin.

Group	Pin Name	GPIO	MFP	Type	Description		
		PF.6	MFP4	O			
		PE.12	MFP4	O			
		PC.0	MFP6	O			
		PH.10	MFP5	O			
	I2S0_MCLK		PB.4	MFP10		O	I2S0 master clock output pin.
			PF.9	MFP4		O	
			PE.9	MFP4		O	
			PC.3	MFP6		O	
			PA.13	MFP2		O	
			PE.0	MFP5		O	
ICE	ICE_CLK	PF.1	MFP14	I	Serial wired debugger clock pin.		
	ICE_DAT	PF.0	MFP14	O	Serial wired debugger data pin.		
INT0	INT0	PB.5	MFP15	I	External interrupt 0 input pin.		
		PA.6	MFP15	I			
INT1	INT1	PB.4	MFP15	I	External interrupt 1 input pin.		
		PA.7	MFP15	I			
INT2	INT2	PB.3	MFP15	I	External interrupt 2 input pin.		
		PC.6	MFP15	I			
INT3	INT3	PB.2	MFP15	I	External interrupt 3 input pin.		
		PC.7	MFP15	I			
INT4	INT4	PA.8	MFP15	I	External interrupt 4 input pin.		
		PB.6	MFP13	I			
INT5	INT5	PD.12	MFP15	I	External interrupt 5 input pin.		
		PB.7	MFP13	I			
INT6	INT6	PD.11	MFP15	I	External interrupt 6 input pin.		
		PB.8	MFP13	I			
INT7	INT7	PD.10	MFP15	I	External interrupt 7 input pin.		
		PB.9	MFP13	I			
OPA0	OPA0_N	PB.1	MFP1	A	Operational amplifier 0 negative input pin.		
	OPA0_O	PB.2	MFP1	A	Operational amplifier 0 output pin.		
	OPA0_P	PB.0	MFP1	A	Operational amplifier 0 positive input pin.		
OPA1	OPA1_N	PA.9	MFP1	A	Operational amplifier 1 negative input pin.		
	OPA1_O	PA.10	MFP1	A	Operational amplifier 1 output pin.		
	OPA1_P	PA.8	MFP1	A	Operational amplifier 1 positive input pin.		

Group	Pin Name	GPIO	MFP	Type	Description
OPA2	OPA2_N	PD.11	MFP1	A	Operational amplifier 2 negative input pin.
	OPA2_O	PD.12	MFP1	A	Operational amplifier 2 output pin.
	OPA2_P	PD.10	MFP1	A	Operational amplifier 2 positive input pin.
QEI0	QEI0_A	PD.11	MFP10	I	Quadrature encoder 0 phase A input
		PA.4	MFP14	I	
		PE.3	MFP11	I	
	QEI0_B	PD.10	MFP10	I	Quadrature encoder 0 phase B input
		PA.3	MFP14	I	
		PE.2	MFP11	I	
	QEI0_INDEX	PD.12	MFP10	I	Quadrature encoder 0 index input
		PA.5	MFP14	I	
		PE.4	MFP11	I	
QEI1	QEI1_A	PA.9	MFP10	I	Quadrature encoder 1 phase A input
		PA.13	MFP12	I	
		PE.6	MFP11	I	
	QEI1_B	PA.8	MFP10	I	Quadrature encoder 1 phase B input
		PA.14	MFP12	I	
		PE.5	MFP11	I	
	QEI1_INDEX	PA.10	MFP10	I	Quadrature encoder 1 index input
		PA.12	MFP12	I	
		PE.7	MFP11	I	
QSPI0	QSPI0_CLK	PF.2	MFP5	I/O	Quad SPI0 serial clock pin.
		PA.2	MFP3	I/O	
		PC.2	MFP4	I/O	
		PH.8	MFP3	I/O	
		PC.14	MFP6	I/O	
	QSPI0_MISO0	PA.1	MFP3	I/O	Quad SPI0 MISO0 (Master In, Slave Out) pin.
		PC.1	MFP4	I/O	
		PE.1	MFP3	I/O	
	QSPI0_MISO1	PA.5	MFP3	I/O	Quad SPI0 MISO1 (Master In, Slave Out) pin.
		PC.5	MFP4	I/O	
		PH.10	MFP3	I/O	
	QSPI0_MOSI0	PA.0	MFP3	I/O	Quad SPI0 MOSI0 (Master Out, Slave In) pin.
		PC.0	MFP4	I/O	

Group	Pin Name	GPIO	MFP	Type	Description	
SC0	QSPI0_MOSI1	PE.0	MFP3	I/O	Quad SPI0 MOSI1 (Master Out, Slave In) pin.	
		PA.4	MFP3	I/O		
		PC.4	MFP4	I/O		
	QSPI0_SS	PH.11	MFP3	I/O	Quad SPI0 slave select pin.	
		PA.3	MFP3	I/O		
		PC.3	MFP4	I/O		
	SC0	SC0_CLK	PH.9	MFP3	I/O	Smart Card 0 clock pin.
			PA.3	MFP3	I/O	
			PC.3	MFP4	I/O	
PH.9			MFP3	I/O		
SC0_DAT		PB.5	MFP9	O	Smart Card 0 data pin.	
		PF.6	MFP3	O		
		PA.0	MFP6	O		
		PE.2	MFP6	O		
SC0_PWR		PB.4	MFP9	I/O	Smart Card 0 power pin.	
		PF.7	MFP3	I/O		
		PA.1	MFP6	I/O		
		PE.3	MFP6	I/O		
SC0_RST		PB.2	MFP9	O	Smart Card 0 reset pin.	
		PF.9	MFP3	O		
		PA.3	MFP6	O		
		PE.5	MFP6	O		
SC0_nCD	PB.3	MFP9	O	Smart Card 0 card detect pin.		
	PF.8	MFP3	O			
	PA.2	MFP6	O			
	PE.4	MFP6	O			
SC1	SC1_CLK	PC.12	MFP9	I	Smart Card 0 card detect pin.	
		PF.10	MFP3	I		
		PA.4	MFP6	I		
		PE.6	MFP6	I		
	SC1_DAT	PC.0	MFP5	O	Smart Card 1 clock pin.	
		PD.4	MFP8	O		
		PG.8	MFP4	O		
		PB.12	MFP3	O		
		PC.1	MFP5	I/O		Smart Card 1 data pin.
		PD.5	MFP8	I/O		
PG.7	MFP4	I/O				

Group	Pin Name	GPIO	MFP	Type	Description
SC1	SC1_PWR	PB.13	MFP3	I/O	Smart Card 1 power pin.
		PC.3	MFP5	O	
		PD.7	MFP8	O	
		PG.5	MFP4	O	
		PB.15	MFP3	O	
	SC1_RST	PC.2	MFP5	O	Smart Card 1 reset pin.
		PD.6	MFP8	O	
		PG.6	MFP4	O	
		PB.14	MFP3	O	
	SC1_nCD	PC.4	MFP5	I	Smart Card 1 card detect pin.
		PD.3	MFP8	I	
		PD.14	MFP4	I	
		PC.14	MFP3	I	
SC2	SC2_CLK	PA.8	MFP3	O	Smart Card 2 clock pin.
		PA.6	MFP6	O	
		PD.0	MFP7	O	
		PA.15	MFP7	O	
		PE.0	MFP4	O	
	SC2_DAT	PA.9	MFP3	I/O	Smart Card 2 data pin.
		PA.7	MFP6	I/O	
		PD.1	MFP7	I/O	
		PA.14	MFP7	I/O	
		PE.1	MFP4	I/O	
	SC2_PWR	PA.11	MFP3	O	Smart Card 2 power pin.
		PC.7	MFP6	O	
		PD.3	MFP7	O	
		PA.12	MFP7	O	
		PH.8	MFP4	O	
	SC2_RST	PA.10	MFP3	O	Smart Card 2 reset pin.
		PC.6	MFP6	O	
		PD.2	MFP7	O	
		PA.13	MFP7	O	
		PH.9	MFP4	O	
SC2_nCD	PC.13	MFP3	I	Smart Card 2 card detect pin.	

Group	Pin Name	GPIO	MFP	Type	Description	
SD0		PA.5	MFP6	I		
		PD.13	MFP7	I		
		PH.10	MFP4	I		
	SD0_CLK		PB.1	MFP3	O	SD/SDIO0 clock output pin
			PE.6	MFP3	O	
	SD0_CMD		PB.0	MFP3	I/O	SD/SDIO0 command/response pin
			PE.7	MFP3	I/O	
	SD0_DAT0		PB.2	MFP3	I/O	SD/SDIO0 data line bit 0.
			PE.2	MFP3	I/O	
	SD0_DAT1		PB.3	MFP3	I/O	SD/SDIO0 data line bit 1.
			PE.3	MFP3	I/O	
	SD0_DAT2		PB.4	MFP3	I/O	SD/SDIO0 data line bit 2.
PE.4			MFP3	I/O		
SD0_DAT3		PB.5	MFP3	I/O	SD/SDIO0 data line bit 3.	
		PE.5	MFP3	I/O		
SD0_nCD		PD.13	MFP3	I	SD/SDIO0 card detect input pin	
		PB.12	MFP9	I		
SD1	SD1_CLK	PA.4	MFP5	O	SD/SDIO1 clock output pin	
		PG.14	MFP3	O		
		PB.6	MFP7	O		
	SD1_CMD		PA.5	MFP5	I/O	SD/SDIO1 command/response pin
			PG.13	MFP3	I/O	
			PB.7	MFP7	I/O	
	SD1_DAT0		PA.8	MFP5	I/O	SD/SDIO1 data line bit 0.
			PA.0	MFP5	I/O	
			PG.12	MFP3	I/O	
	SD1_DAT1		PA.9	MFP5	I/O	SD/SDIO1 data line bit 1.
			PA.1	MFP5	I/O	
			PG.11	MFP3	I/O	
	SD1_DAT2		PA.10	MFP5	I/O	SD/SDIO1 data line bit 2.
			PA.2	MFP5	I/O	
			PG.10	MFP3	I/O	
	SD1_DAT3		PA.11	MFP5	I/O	SD/SDIO1 data line bit 3.
			PA.3	MFP5	I/O	

Group	Pin Name	GPIO	MFP	Type	Description
	SD1_nCD	PG.9	MFP3	I/O	SD/SDIO1 card detect input pin
		PA.6	MFP5	I	
		PE.14	MFP5	I	
		PG.15	MFP3	I	
SPI0	SPI0_CLK	PF.8	MFP5	I/O	SPI0 serial clock pin.
		PA.2	MFP4	I/O	
		PD.2	MFP4	I/O	
		PB.14	MFP4	I/O	
	SPI0_I2SMCLK	PB.0	MFP8	I/O	SPI0 I2S master clock output pin
		PF.10	MFP5	I/O	
		PA.4	MFP4	I/O	
		PD.13	MFP4	I/O	
		PC.14	MFP4	I/O	
		PB.11	MFP9	I/O	
	SPI0_MISO	PF.7	MFP5	I/O	SPI0 MISO (Master In, Slave Out) pin.
		PA.1	MFP4	I/O	
		PD.1	MFP4	I/O	
		PB.13	MFP4	I/O	
	SPI0_MOSI	PF.6	MFP5	I/O	SPI0 MOSI (Master Out, Slave In) pin.
		PA.0	MFP4	I/O	
		PD.0	MFP4	I/O	
		PB.12	MFP4	I/O	
	SPI0_SS	PF.9	MFP5	I/O	SPI0 slave select pin.
		PA.3	MFP4	I/O	
PD.3		MFP4	I/O		
PB.15		MFP4	I/O		
SPI1	SPI1_CLK	PB.3	MFP5	I/O	SPI1 serial clock pin.
		PH.6	MFP3	I/O	
		PA.7	MFP4	I/O	
		PC.1	MFP7	I/O	
		PD.5	MFP5	I/O	
		PH.8	MFP6	I/O	
	SPI1_I2SMCLK	PB.1	MFP5	I/O	SPI1 I2S master clock output pin
		PH.3	MFP3	I/O	

Group	Pin Name	GPIO	MFP	Type	Description	
SPI1		PA.5	MFP4	I/O		
		PC.4	MFP7	I/O		
		PD.13	MFP5	I/O		
		PH.10	MFP6	I/O		
	SPI1_MISO		PB.5	MFP5	I/O	SPI1 MISO (Master In, Slave Out) pin.
			PH.4	MFP3	I/O	
			PC.7	MFP4	I/O	
			PC.3	MFP7	I/O	
			PD.7	MFP5	I/O	
			PE.1	MFP6	I/O	
	SPI1_MOSI		PB.4	MFP5	I/O	SPI1 MOSI (Master Out, Slave In) pin.
			PH.5	MFP3	I/O	
			PC.6	MFP4	I/O	
			PC.2	MFP7	I/O	
			PD.6	MFP5	I/O	
			PE.0	MFP6	I/O	
	SPI1_SS		PB.2	MFP5	I/O	SPI1 slave select pin.
			PH.7	MFP3	I/O	
			PA.6	MFP4	I/O	
PC.0			MFP7	I/O		
PD.4			MFP5	I/O		
PH.9			MFP6	I/O		
SPI2	SPI2_CLK	PA.10	MFP4	I/O	SPI2 serial clock pin.	
		PG.3	MFP3	I/O		
		PE.8	MFP5	I/O		
		PA.13	MFP5	I/O		
	SPI2_I2SMCLK		PC.13	MFP4	I/O	SPI2 I2S master clock output pin
			PG.1	MFP3	I/O	
			PE.12	MFP5	I/O	
	SPI2_MISO		PA.9	MFP4	I/O	SPI2 MISO (Master In, Slave Out) pin.
			PG.4	MFP3	I/O	
			PE.9	MFP5	I/O	
			PA.14	MFP5	I/O	
	SPI2_MOSI		PA.8	MFP4	I/O	SPI2 MOSI (Master Out, Slave In) pin.

Group	Pin Name	GPIO	MFP	Type	Description	
		PF.11	MFP3	I/O		
		PE.10	MFP5	I/O		
		PA.15	MFP5	I/O		
	SPI2_SS	PA.11	MFP4	I/O		SPI2 slave select pin.
		PG.2	MFP3	I/O		
		PE.11	MFP5	I/O		
		PA.12	MFP5	I/O		
SPI3	SPI3_CLK	PC.10	MFP6	I/O	SPI3 serial clock pin.	
		PE.4	MFP5	I/O		
		PG.6	MFP3	I/O		
		PB.11	MFP11	I/O		
	SPI3_I2SMCLK	PB.1	MFP6	I/O	SPI3 I2S master clock output pin	
		PE.6	MFP5	I/O		
		PD.14	MFP3	I/O		
	SPI3_MISO	PC.12	MFP6	I/O	SPI3 MISO (Master In, Slave Out) pin.	
		PE.3	MFP5	I/O		
		PG.7	MFP3	I/O		
		PB.9	MFP11	I/O		
	SPI3_MOSI	PC.11	MFP6	I/O	SPI3 MOSI (Master Out, Slave In) pin.	
		PE.2	MFP5	I/O		
		PG.8	MFP3	I/O		
		PB.8	MFP11	I/O		
	SPI3_SS	PC.9	MFP6	I/O	SPI3 slave select pin.	
PE.5		MFP5	I/O			
PG.5		MFP3	I/O			
PB.10		MFP11	I/O			
SPIM	SPIM_CLK	PA.2	MFP2	I/O	SPIM serial clock pin.	
		PC.2	MFP3	I/O		
		PG.12	MFP4	I/O		
		PE.4	MFP4	I/O		
	SPIM_D2	PA.5	MFP2	I/O	SPIM data 2 pin for Quad Mode I/O.	
		PC.5	MFP3	I/O		
		PG.9	MFP4	I/O		
		PE.7	MFP4	I/O		

Group	Pin Name	GPIO	MFP	Type	Description
	SPIM_D3	PA.4	MFP2	I/O	SPIM data 3 pin for Quad Mode I/O.
		PC.4	MFP3	I/O	
		PG.10	MFP4	I/O	
		PE.6	MFP4	I/O	
	SPIM_MISO	PA.1	MFP2	I/O	SPIM MISO (Master In, Slave Out) pin.
		PC.1	MFP3	I/O	
		PG.13	MFP4	I/O	
		PE.3	MFP4	I/O	
	SPIM_MOSI	PA.0	MFP2	I/O	SPIM MOSI (Master Out, Slave In) pin.
		PC.0	MFP3	I/O	
		PG.14	MFP4	I/O	
		PE.2	MFP4	I/O	
	SPIM_SS	PA.3	MFP2	I/O	SPIM slave select pin.
		PC.3	MFP3	I/O	
		PG.11	MFP4	I/O	
		PE.5	MFP4	I/O	
TAMPER0	TAMPER0	PF.6	MFP10	I/O	TAMPER detector loop pin 0.
TAMPER1	TAMPER1	PF.7	MFP10	I/O	TAMPER detector loop pin 1.
TAMPER2	TAMPER2	PF.8	MFP10	I/O	TAMPER detector loop pin 2.
TAMPER3	TAMPER3	PF.9	MFP10	I/O	TAMPER detector loop pin 3.
TAMPER4	TAMPER4	PF.10	MFP10	I/O	TAMPER detector loop pin 4.
TAMPER5	TAMPER5	PF.11	MFP10	I/O	TAMPER detector loop pin 5.
TM0	TM0	PB.5	MFP14	I/O	Timer0 event counter input/toggle output pin.
		PG.2	MFP13	I/O	
		PC.7	MFP14	I/O	
	TM0_EXT	PA.11	MFP13	I/O	Timer0 external capture input/toggle output pin.
		PH.0	MFP13	I/O	
		PB.15	MFP13	I/O	
TM1	TM1	PB.4	MFP14	I/O	Timer1 event counter input/toggle output pin.
		PG.3	MFP13	I/O	
		PC.6	MFP14	I/O	
		PC.14	MFP13	I/O	
	TM1_EXT	PA.10	MFP13	I/O	Timer1 external capture input/toggle output pin.
		PH.1	MFP13	I/O	

Group	Pin Name	GPIO	MFP	Type	Description
		PB.14	MFP13	I/O	
TM2	TM2	PB.3	MFP14	I/O	Timer2 event counter input/toggle output pin.
		PG.4	MFP13	I/O	
		PA.7	MFP14	I/O	
		PD.0	MFP14	I/O	
	TM2_EXT	PA.9	MFP13	I/O	Timer2 external capture input/toggle output pin.
		PH.2	MFP13	I/O	
PB.13		MFP13	I/O		
TM3	TM3	PB.2	MFP14	I/O	Timer3 event counter input/toggle output pin.
		PF.11	MFP13	I/O	
		PA.6	MFP14	I/O	
	TM3_EXT	PA.8	MFP13	I/O	Timer3 external capture input/toggle output pin.
		PH.3	MFP13	I/O	
		PB.12	MFP13	I/O	
TRACE	TRACE_CLK	PE.8	MFP14	O	ETM Trace Clock output pin
	TRACE_DATA0	PE.9	MFP14	O	ETM Trace Data 0 output pin
	TRACE_DATA1	PE.10	MFP14	O	ETM Trace Data 1 output pin
	TRACE_DATA2	PE.11	MFP14	O	ETM Trace Data 2 output pin
	TRACE_DATA3	PE.12	MFP14	O	ETM Trace Data 3 output pin
UART0	UART0_RXD	PC.11	MFP3	I	UART0 data receiver input pin.
		PF.2	MFP3	I	
		PA.6	MFP7	I	
		PA.0	MFP7	I	
		PD.2	MFP9	I	
		PA.15	MFP3	I	
		PH.11	MFP8	I	
		PB.12	MFP6	I	
	PB.8	MFP5	I		
	UART0_TXD	PC.12	MFP3	O	UART0 data transmitter output pin.
		PF.3	MFP3	O	
		PA.7	MFP7	O	
		PA.1	MFP7	O	
		PD.3	MFP9	O	
PA.14		MFP3	O		

Group	Pin Name	GPIO	MFP	Type	Description	
		PH.10	MFP8	O		
		PB.13	MFP6	O		
		PB.9	MFP5	O		
	UART0_nCTS	PC.7	MFP7	I		UART0 clear to Send input pin.
		PA.5	MFP7	I		
		PB.15	MFP6	I		
		PB.11	MFP5	I		
	UART0_nRTS	PC.6	MFP7	O		UART0 request to Send output pin.
		PA.4	MFP7	O		
		PB.14	MFP6	O		
		PB.10	MFP5	O		
	UART1	UART1_RXD	PB.2	MFP6		I
PA.8			MFP7	I		
PD.10			MFP3	I		
PG.1			MFP8	I		
PC.8			MFP8	I		
PA.2			MFP8	I		
PF.1			MFP2	I		
PD.6			MFP3	I		
PH.9			MFP10	I		
PB.6			MFP6	I		
UART1_TXD		PB.3	MFP6	O	UART1 data transmitter output pin.	
		PA.9	MFP7	O		
		PD.11	MFP3	O		
		PG.0	MFP8	O		
		PE.13	MFP8	O		
		PA.3	MFP8	O		
		PF.0	MFP2	O		
		PD.7	MFP3	O		
		PH.8	MFP10	O		
PB.7		MFP6	O			
UART1_nCTS	PE.11	MFP8	I	UART1 clear to Send input pin.		
	PA.1	MFP8	I			
	PB.9	MFP6	I			

Group	Pin Name	GPIO	MFP	Type	Description	
	UART1_nRTS	PE.12	MFP8	O	UART1 request to Send output pin.	
		PA.0	MFP8	O		
		PB.8	MFP6	O		
UART2	UART2_RXD	PB.0	MFP7	I	UART2 data receiver input pin.	
		PD.12	MFP7	I		
		PG.0	MFP6	I		
		PF.5	MFP2	I		
		PE.9	MFP7	I		
		PE.15	MFP3	I		
		PC.4	MFP8	I		
		PC.0	MFP8	I		
	UART2_TXD	PB.1	MFP7	O	UART2 data transmitter output pin.	
		PC.13	MFP7	O		
		PG.1	MFP6	O		
		PF.4	MFP2	O		
		PE.8	MFP7	O		
		PE.14	MFP3	O		
		PC.5	MFP8	O		
		PC.1	MFP8	O		
	UART2_nCTS	PF.5	MFP4	I	UART2 clear to Send input pin.	
		PD.9	MFP4	I		
		PC.2	MFP8	I		
	UART2_nRTS	PF.4	MFP4	O	UART2 request to Send output pin.	
		PD.8	MFP4	O		
		PC.3	MFP8	O		
	UART3	UART3_RXD	PC.9	MFP7	I	UART3 data receiver input pin.
			PE.11	MFP7	I	
			PC.2	MFP11	I	
			PD.0	MFP5	I	
			PE.0	MFP7	I	
			PB.14	MFP7	I	
UART3_TXD		PC.10	MFP7	O	UART3 data transmitter output pin.	
		PE.10	MFP7	O		
		PC.3	MFP11	O		

Group	Pin Name	GPIO	MFP	Type	Description	
		PD.1	MFP5	O		
		PE.1	MFP7	O		
		PB.15	MFP7	O		
	UART3_nCTS	PD.2	MFP5	I		UART3 clear to Send input pin.
		PH.9	MFP7	I		
		PB.12	MFP7	I		
	UART3_nRTS	PD.3	MFP5	O		UART3 request to Send output pin.
		PH.8	MFP7	O		
		PB.13	MFP7	O		
UART4	UART4_RXD	PF.6	MFP6	I	UART4 data receiver input pin.	
		PH.3	MFP5	I		
		PC.6	MFP5	I		
		PA.2	MFP7	I		
		PC.4	MFP11	I		
		PA.13	MFP3	I		
		PH.11	MFP7	I		
		PB.10	MFP6	I		
	UART4_TXD	PF.7	MFP6	O	UART4 data transmitter output pin.	
		PH.2	MFP5	O		
		PC.7	MFP5	O		
		PA.3	MFP7	O		
		PC.5	MFP11	O		
		PA.12	MFP3	O		
		PH.10	MFP7	O		
		PB.11	MFP6	O		
	UART4_nCTS	PC.8	MFP5	I	UART4 clear to Send input pin.	
		PE.1	MFP9	I		
	UART4_nRTS	PE.13	MFP5	O	UART4 request to Send output pin.	
		PE.0	MFP9	O		
	UART5	UART5_RXD	PB.4	MFP7	I	UART5 data receiver input pin.
			PH.1	MFP4	I	
			PA.4	MFP8	I	
			PE.6	MFP8	I	
		UART5_TXD	PB.5	MFP7	O	UART5 data transmitter output pin.

Group	Pin Name	GPIO	MFP	Type	Description
		PH.0	MFP4	O	
		PA.5	MFP8	O	
		PE.7	MFP8	O	
	UART5_nCTS	PB.2	MFP7	I	UART5 clear to Send input pin.
		PH.3	MFP4	I	
	UART5_nRTS	PB.3	MFP7	O	UART5 request to Send output pin.
PH.2		MFP4	O		
USB	USB_D+	PA.14	MFP14	A	USB differential signal D+.
	USB_D-	PA.13	MFP14	A	USB differential signal D-.
	USB_OTG_ID	PA.15	MFP14	I	USB_ identification.
	USB_VBUS	PA.12	MFP14	P	Power supply from USB host or HUB.
	USB_VBUS_EN	PB.15	MFP14	O	USB external VBUS regulator enable pin.
		PB.6	MFP14	O	
	USB_VBUS_ST	PD.4	MFP14	I	USB external VBUS regulator status pin.
		PC.14	MFP14	I	
		PB.7	MFP14	I	
USCI0	USCI0_CLK	PA.11	MFP6	I/O	USCI0 clock pin.
		PD.0	MFP3	I/O	
		PE.2	MFP7	I/O	
		PB.12	MFP5	I/O	
	USCI0_CTL0	PC.13	MFP6	I/O	USCI0 control 0 pin.
		PD.4	MFP3	I/O	
		PE.6	MFP7	I/O	
		PC.14	MFP5	I/O	
	USCI0_CTL1	PA.8	MFP6	I/O	USCI0 control 1 pin.
		PD.3	MFP3	I/O	
		PE.5	MFP7	I/O	
		PB.15	MFP5	I/O	
	USCI0_DAT0	PA.10	MFP6	I/O	USCI0 data 0 pin.
		PD.1	MFP3	I/O	
		PE.3	MFP7	I/O	
		PB.13	MFP5	I/O	
	USCI0_DAT1	PA.9	MFP6	I/O	USCI0 data 1 pin.
		PD.2	MFP3	I/O	

Group	Pin Name	GPIO	MFP	Type	Description	
		PE.4	MFP7	I/O		
		PB.14	MFP5	I/O		
USCI1	USCI1_CLK	PB.1	MFP8	I/O	USCI1 clock pin.	
		PE.12	MFP6	I/O		
		PD.7	MFP6	I/O		
		PB.8	MFP4	I/O		
	USCI1_CTL0	USCI1_CTL0	PB.5	MFP8	I/O	USCI1 control 0 pin.
			PE.9	MFP6	I/O	
			PD.3	MFP6	I/O	
			PB.10	MFP4	I/O	
	USCI1_CTL1	USCI1_CTL1	PB.4	MFP8	I/O	USCI1 control 1 pin.
			PE.8	MFP6	I/O	
			PD.4	MFP6	I/O	
			PB.9	MFP4	I/O	
	USCI1_DAT0	USCI1_DAT0	PB.2	MFP8	I/O	USCI1 data 0 pin.
			PE.10	MFP6	I/O	
			PD.5	MFP6	I/O	
			PB.7	MFP4	I/O	
USCI1_DAT1	USCI1_DAT1	PB.3	MFP8	I/O	USCI1 data 1 pin.	
		PE.11	MFP6	I/O		
		PD.6	MFP6	I/O		
		PB.6	MFP4	I/O		
X32	X32_IN	PF.5	MFP10	I	External 32.768 kHz crystal input pin.	
	X32_OUT	PF.4	MFP10	O	External 32.768 kHz crystal output pin.	
XT1	XT1_IN	PF.3	MFP10	I	External 4–24 MHz (high speed) crystal input pin.	
	XT1_OUT	PF.2	MFP10	O	External 4–24 MHz (high speed) crystal output pin.	

4.2.8 M480 Multi-function Summary Table Sorted by GPIO

	Pin Name	Type	MFP	Description
PA.0	PA.0	I/O	MFP0	General purpose digital I/O pin.
	SPIM_MOSI	I/O	MFP2	SPIM MOSI (Master Out, Slave In) pin.
	QSPI0_MOSI0	I/O	MFP3	Quad SPI0 MOSI0 (Master Out, Slave In) pin.
	SPI0_MOSI	I/O	MFP4	SPI0 MOSI (Master Out, Slave In) pin.
	SD1_DAT0	I/O	MFP5	SD/SDIO1 data line bit 0.
	SC0_CLK	O	MFP6	Smart Card 0 clock pin.
	UART0_RXD	I	MFP7	UART0 data receiver input pin.
	UART1_nRTS	O	MFP8	UART1 request to Send output pin.
	I2C2_SDA	I/O	MFP9	I ² C2 data input/output pin.
	BPWM0_CH0	I/O	MFP12	BPWM0 channel 0 output/capture input.
	EPWM0_CH5	I/O	MFP13	EPWM0 channel 5 output/capture input.
	DAC0_ST	I	MFP15	DAC0 external trigger input.
PA.1	PA.1	I/O	MFP0	General purpose digital I/O pin.
	SPIM_MISO	I/O	MFP2	SPIM MISO (Master In, Slave Out) pin.
	QSPI0_MISO0	I/O	MFP3	Quad SPI0 MISO0 (Master In, Slave Out) pin.
	SPI0_MISO	I/O	MFP4	SPI0 MISO (Master In, Slave Out) pin.
	SD1_DAT1	I/O	MFP5	SD/SDIO1 data line bit 1.
	SC0_DAT	I/O	MFP6	Smart Card 0 data pin.
	UART0_TXD	O	MFP7	UART0 data transmitter output pin.
	UART1_nCTS	I	MFP8	UART1 clear to Send input pin.
	I2C2_SCL	I/O	MFP9	I ² C2 clock pin.
	BPWM0_CH1	I/O	MFP12	BPWM0 channel 1 output/capture input.
	EPWM0_CH4	I/O	MFP13	EPWM0 channel 4 output/capture input.
	DAC1_ST	I	MFP15	DAC1 external trigger input.
PA.2	PA.2	I/O	MFP0	General purpose digital I/O pin.
	SPIM_CLK	I/O	MFP2	SPIM serial clock pin.
	QSPI0_CLK	I/O	MFP3	Quad SPI0 serial clock pin.
	SPI0_CLK	I/O	MFP4	SPI0 serial clock pin.
	SD1_DAT2	I/O	MFP5	SD/SDIO1 data line bit 2.
	SC0_RST	O	MFP6	Smart Card 0 reset pin.
	UART4_RXD	I	MFP7	UART4 data receiver input pin.
	UART1_RXD	I	MFP8	UART1 data receiver input pin.
	I2C1_SDA	I/O	MFP9	I ² C1 data input/output pin.

	Pin Name	Type	MFP	Description
	BPWM0_CH2	I/O	MFP12	BPWM0 channel 2 output/capture input.
	EPWM0_CH3	I/O	MFP13	EPWM0 channel 3 output/capture input.
PA.3	PA.3	I/O	MFP0	General purpose digital I/O pin.
	SPIM_SS	I/O	MFP2	SPIM slave select pin.
	QSPI0_SS	I/O	MFP3	Quad SPI0 slave select pin.
	SPI0_SS	I/O	MFP4	SPI0 slave select pin.
	SD1_DAT3	I/O	MFP5	SD/SDIO1 data line bit 3.
	SC0_PWR	O	MFP6	Smart Card 0 power pin.
	UART4_TXD	O	MFP7	UART4 data transmitter output pin.
	UART1_TXD	O	MFP8	UART1 data transmitter output pin.
	I2C1_SCL	I/O	MFP9	I ² C1 clock pin.
	BPWM0_CH3	I/O	MFP12	BPWM0 channel 3 output/capture input.
	EPWM0_CH2	I/O	MFP13	EPWM0 channel 2 output/capture input.
	QEIO_B	I	MFP14	Quadrature encoder 0 phase B input
PA.4	PA.4	I/O	MFP0	General purpose digital I/O pin.
	SPIM_D3	I/O	MFP2	SPIM data 3 pin for Quad Mode I/O.
	QSPI0_MOSI1	I/O	MFP3	Quad SPI0 MOSI1 (Master Out, Slave In) pin.
	SPI0_I2SMCLK	I/O	MFP4	SPI0 I ² S master clock output pin
	SD1_CLK	O	MFP5	SD/SDIO1 clock output pin
	SC0_nCD	I	MFP6	Smart Card 0 card detect pin.
	UART0_nRTS	O	MFP7	UART0 request to Send output pin.
	UART5_RXD	I	MFP8	UART5 data receiver input pin.
	I2C0_SDA	I/O	MFP9	I ² C0 data input/output pin.
	CAN0_RXD	I	MFP10	CAN0 bus receiver input.
	BPWM0_CH4	I/O	MFP12	BPWM0 channel 4 output/capture input.
	EPWM0_CH1	I/O	MFP13	EPWM0 channel 1 output/capture input.
QEIO_A	I	MFP14	Quadrature encoder 0 phase A input	
PA.5	PA.5	I/O	MFP0	General purpose digital I/O pin.
	SPIM_D2	I/O	MFP2	SPIM data 2 pin for Quad Mode I/O.
	QSPI0_MISO1	I/O	MFP3	Quad SPI0 MISO1 (Master In, Slave Out) pin.
	SPI1_I2SMCLK	I/O	MFP4	SPI1 I ² S master clock output pin
	SD1_CMD	I/O	MFP5	SD/SDIO1 command/response pin
	SC2_nCD	I	MFP6	Smart Card 2 card detect pin.
	UART0_nCTS	I	MFP7	UART0 clear to Send input pin.

	Pin Name	Type	MFP	Description
	UART5_TXD	O	MFP8	UART5 data transmitter output pin.
	I2C0_SCL	I/O	MFP9	I ² C0 clock pin.
	CAN0_TXD	O	MFP10	CAN0 bus transmitter output.
	BPWM0_CH5	I/O	MFP12	BPWM0 channel 5 output/capture input.
	EPWM0_CH0	I/O	MFP13	EPWM0 channel 0 output/capture input.
	QEIO_INDEX	I	MFP14	Quadrature encoder 0 index input
PA.6	PA.6	I/O	MFP0	General purpose digital I/O pin.
	EBI_AD6	I/O	MFP2	EBI address/data bus bit 6.
	EMAC_RMII_RXERR	I	MFP3	EMAC RMII Receive Data Error input pin.
	SPI1_SS	I/O	MFP4	SPI1 slave select pin.
	SD1_nCD	I	MFP5	SD/SDIO1 card detect input pin
	SC2_CLK	O	MFP6	Smart Card 2 clock pin.
	UART0_RXD	I	MFP7	UART0 data receiver input pin.
	I2C1_SDA	I/O	MFP8	I ² C1 data input/output pin.
	EPWM1_CH5	I/O	MFP11	EPWM1 channel 5 output/capture input.
	BPWM1_CH3	I/O	MFP12	BPWM1 channel 3 output/capture input.
	ACMP1_WLAT	I	MFP13	Analog comparator 1 window latch input pin
	TM3	I/O	MFP14	Timer3 event counter input/toggle output pin.
	INT0	I	MFP15	External interrupt 0 input pin.
PA.7	PA.7	I/O	MFP0	General purpose digital I/O pin.
	EBI_AD7	I/O	MFP2	EBI address/data bus bit 7.
	EMAC_RMII_CRSDV	I	MFP3	EMAC RMII Carrier Sense/Receive Data input pin.
	SPI1_CLK	I/O	MFP4	SPI1 serial clock pin.
	SC2_DAT	I/O	MFP6	Smart Card 2 data pin.
	UART0_TXD	O	MFP7	UART0 data transmitter output pin.
	I2C1_SCL	I/O	MFP8	I ² C1 clock pin.
	EPWM1_CH4	I/O	MFP11	EPWM1 channel 4 output/capture input.
	BPWM1_CH2	I/O	MFP12	BPWM1 channel 2 output/capture input.
	ACMP0_WLAT	I	MFP13	Analog comparator 0 window latch input pin
	TM2	I/O	MFP14	Timer2 event counter input/toggle output pin.
	INT1	I	MFP15	External interrupt 1 input pin.
PA.8	PA.8	I/O	MFP0	General purpose digital I/O pin.
	OPA1_P	A	MFP1	Operational amplifier 1 positive input pin.
	EBI_ALE	O	MFP2	EBI address latch enable output pin.

	Pin Name	Type	MFP	Description
	SC2_CLK	O	MFP3	Smart Card 2 clock pin.
	SPI2_MOSI	I/O	MFP4	SPI2 MOSI (Master Out, Slave In) pin.
	SD1_DAT0	I/O	MFP5	SD/SDIO1 data line bit 0.
	USCI0_CTL1	I/O	MFP6	USCI0 control 1 pin.
	UART1_RXD	I	MFP7	UART1 data receiver input pin.
	BPWM0_CH3	I/O	MFP9	BPWM0 channel 3 output/capture input.
	QE1_B	I	MFP10	Quadrature encoder 1 phase B input
	ECAP0_IC2	I	MFP11	Enhanced capture unit 0 input 2 pin.
	TM3_EXT	I/O	MFP13	Timer3 external capture input/toggle output pin.
	INT4	I	MFP15	External interrupt 4 input pin.
PA.9	PA.9	I/O	MFP0	General purpose digital I/O pin.
	OPA1_N	A	MFP1	Operational amplifier 1 negative input pin.
	EBI_MCLK	O	MFP2	EBI external clock output pin.
	SC2_DAT	I/O	MFP3	Smart Card 2 data pin.
	SPI2_MISO	I/O	MFP4	SPI2 MISO (Master In, Slave Out) pin.
	SD1_DAT1	I/O	MFP5	SD/SDIO1 data line bit 1.
	USCI0_DAT1	I/O	MFP6	USCI0 data 1 pin.
	UART1_TXD	O	MFP7	UART1 data transmitter output pin.
	BPWM0_CH2	I/O	MFP9	BPWM0 channel 2 output/capture input.
	QE1_A	I	MFP10	Quadrature encoder 1 phase A input
	ECAP0_IC1	I	MFP11	Enhanced capture unit 0 input 1 pin.
	TM2_EXT	I/O	MFP13	Timer2 external capture input/toggle output pin.
PA.10	PA.10	I/O	MFP0	General purpose digital I/O pin.
	ACMP1_P0	A	MFP1	Analog comparator 1 positive input 0 pin.
	OPA1_O	A	MFP1	Operational amplifier 1 output pin.
	EBI_nWR	O	MFP2	EBI write enable output pin.
	SC2_RST	O	MFP3	Smart Card 2 reset pin.
	SPI2_CLK	I/O	MFP4	SPI2 serial clock pin.
	SD1_DAT2	I/O	MFP5	SD/SDIO1 data line bit 2.
	USCI0_DAT0	I/O	MFP6	USCI0 data 0 pin.
	I2C2_SDA	I/O	MFP7	I ² C2 data input/output pin.
	BPWM0_CH1	I/O	MFP9	BPWM0 channel 1 output/capture input.
	QE1_INDEX	I	MFP10	Quadrature encoder 1 index input
	ECAP0_IC0	I	MFP11	Enhanced capture unit 0 input 0 pin.

	Pin Name	Type	MFP	Description
	TM1_EXT	I/O	MFP13	Timer1 external capture input/toggle output pin.
	DAC0_ST	I	MFP14	DAC0 external trigger input.
PA.11	PA.11	I/O	MFP0	General purpose digital I/O pin.
	ACMP0_P0	A	MFP1	Analog comparator 0 positive input 0 pin.
	EBI_nRD	O	MFP2	EBI read enable output pin.
	SC2_PWR	O	MFP3	Smart Card 2 power pin.
	SPI2_SS	I/O	MFP4	SPI2 slave select pin.
	SD1_DAT3	I/O	MFP5	SD/SDIO1 data line bit 3.
	USCI0_CLK	I/O	MFP6	USCI0 clock pin.
	I2C2_SCL	I/O	MFP7	I ² C2 clock pin.
	BPWM0_CH0	I/O	MFP9	BPWM0 channel 0 output/capture input.
	EPWM0_SYNC_OUT	O	MFP10	EPWM0 counter synchronous trigger output pin.
	TM0_EXT	I/O	MFP13	Timer0 external capture input/toggle output pin.
	DAC1_ST	I	MFP14	DAC1 external trigger input.
PA.12	PA.12	I/O	MFP0	General purpose digital I/O pin.
	I2S0_BCLK	O	MFP2	I ² S0 bit clock output pin.
	UART4_TXD	O	MFP3	UART4 data transmitter output pin.
	I2C1_SCL	I/O	MFP4	I ² C1 clock pin.
	SPI2_SS	I/O	MFP5	SPI2 slave select pin.
	CAN0_TXD	O	MFP6	CAN0 bus transmitter output.
	SC2_PWR	O	MFP7	Smart Card 2 power pin.
	BPWM1_CH2	I/O	MFP11	BPWM1 channel 2 output/capture input.
	QE1_INDEX	I	MFP12	Quadrature encoder 1 index input
USB_VBUS	P	MFP14	Power supply from USB host or HUB.	
PA.13	PA.13	I/O	MFP0	General purpose digital I/O pin.
	I2S0_MCLK	O	MFP2	I ² S0 master clock output pin.
	UART4_RXD	I	MFP3	UART4 data receiver input pin.
	I2C1_SDA	I/O	MFP4	I ² C1 data input/output pin.
	SPI2_CLK	I/O	MFP5	SPI2 serial clock pin.
	CAN0_RXD	I	MFP6	CAN0 bus receiver input.
	SC2_RST	O	MFP7	Smart Card 2 reset pin.
	BPWM1_CH3	I/O	MFP11	BPWM1 channel 3 output/capture input.
	QE1_A	I	MFP12	Quadrature encoder 1 phase A input
	USB_D-	A	MFP14	USB differential signal D-.

	Pin Name	Type	MFP	Description
PA.14	PA.14	I/O	MFP0	General purpose digital I/O pin.
	I2S0_DI	I	MFP2	I ² S0 data input pin.
	UART0_TXD	O	MFP3	UART0 data transmitter output pin.
	SPI2_MISO	I/O	MFP5	SPI2 MISO (Master In, Slave Out) pin.
	I2C2_SCL	I/O	MFP6	I ² C2 clock pin.
	SC2_DAT	I/O	MFP7	Smart Card 2 data pin.
	BPWM1_CH4	I/O	MFP11	BPWM1 channel 4 output/capture input.
	QE11_B	I	MFP12	Quadrature encoder 1 phase B input
	USB_D+	A	MFP14	USB differential signal D+.
PA.15	PA.15	I/O	MFP0	General purpose digital I/O pin.
	I2S0_DO	O	MFP2	I ² S0 data output pin.
	UART0_RXD	I	MFP3	UART0 data receiver input pin.
	SPI2_MOSI	I/O	MFP5	SPI2 MOSI (Master Out, Slave In) pin.
	I2C2_SDA	I/O	MFP6	I ² C2 data input/output pin.
	SC2_CLK	O	MFP7	Smart Card 2 clock pin.
	BPWM1_CH5	I/O	MFP11	BPWM1 channel 5 output/capture input.
	EPWM0_SYNC_IN	I	MFP12	EPWM0 counter synchronous trigger input pin.
	USB_OTG_ID	I	MFP14	USB_ identification.
PB.0	PB.0	I/O	MFP0	General purpose digital I/O pin.
	EADC0_CH0	A	MFP1	EADC0 channel 0 analog input.
	OPA0_P	A	MFP1	Operational amplifier 0 positive input pin.
	EBI_ADR9	O	MFP2	EBI address bus bit 9.
	SD0_CMD	I/O	MFP3	SD/SDIO0 command/response pin
	UART2_RXD	I	MFP7	UART2 data receiver input pin.
	SPI0_I2SMCLK	I/O	MFP8	SPI0 I ² S master clock output pin
	I2C1_SDA	I/O	MFP9	I ² C1 data input/output pin.
	EPWM0_CH5	I/O	MFP11	EPWM0 channel 5 output/capture input.
	EPWM1_CH5	I/O	MFP12	EPWM1 channel 5 output/capture input.
	EPWM0_BRAKE1	I	MFP13	EPWM0 Brake 1 input pin.
PB.1	PB.1	I/O	MFP0	General purpose digital I/O pin.
	EADC0_CH1	A	MFP1	EADC0 channel 1 analog input.
	OPA0_N	A	MFP1	Operational amplifier 0 negative input pin.
	EBI_ADR8	O	MFP2	EBI address bus bit 8.
	SD0_CLK	O	MFP3	SD/SDIO0 clock output pin

	Pin Name	Type	MFP	Description
	EMAC_RMII_RXERR	I	MFP4	EMAC RMII Receive Data Error input pin.
	SPI1_I2SMCLK	I/O	MFP5	SPI1 I ² S master clock output pin
	SPI3_I2SMCLK	I/O	MFP6	SPI3 I ² S master clock output pin
	UART2_TXD	O	MFP7	UART2 data transmitter output pin.
	USC11_CLK	I/O	MFP8	USC11 clock pin.
	I2C1_SCL	I/O	MFP9	I ² C1 clock pin.
	I2S0_LRCK	O	MFP10	I ² S0 left right channel clock output pin.
	EPWM0_CH4	I/O	MFP11	EPWM0 channel 4 output/capture input.
	EPWM1_CH4	I/O	MFP12	EPWM1 channel 4 output/capture input.
	EPWM0_BRAKE0	I	MFP13	EPWM0 Brake 0 input pin.
PB.2	PB.2	I/O	MFP0	General purpose digital I/O pin.
	EADC0_CH2	A	MFP1	EADC0 channel 2 analog input.
	ACMP0_P1	A	MFP1	Analog comparator 0 positive input 1 pin.
	OPA0_O	A	MFP1	Operational amplifier 0 output pin.
	EBI_ADR3	O	MFP2	EBI address bus bit 3.
	SD0_DAT0	I/O	MFP3	SD/SDIO0 data line bit 0.
	EMAC_RMII_CRSDV	I	MFP4	EMAC RMII Carrier Sense/Receive Data input pin.
	SPI1_SS	I/O	MFP5	SPI1 slave select pin.
	UART1_RXD	I	MFP6	UART1 data receiver input pin.
	UART5_nCTS	I	MFP7	UART5 clear to Send input pin.
	USC11_DAT0	I/O	MFP8	USC11 data 0 pin.
	SC0_PWR	O	MFP9	Smart Card 0 power pin.
	I2S0_DO	O	MFP10	I ² S0 data output pin.
	EPWM0_CH3	I/O	MFP11	EPWM0 channel 3 output/capture input.
	TM3	I/O	MFP14	Timer3 event counter input/toggle output pin.
INT3	I	MFP15	External interrupt 3 input pin.	
PB.3	PB.3	I/O	MFP0	General purpose digital I/O pin.
	EADC0_CH3	A	MFP1	EADC0 channel 3 analog input.
	ACMP0_N	A	MFP1	Analog comparator 0 negative input pin.
	EBI_ADR2	O	MFP2	EBI address bus bit 2.
	SD0_DAT1	I/O	MFP3	SD/SDIO0 data line bit 1.
	EMAC_RMII_RXD1	I	MFP4	EMAC RMII Receive Data bus bit 1.
	SPI1_CLK	I/O	MFP5	SPI1 serial clock pin.
	UART1_TXD	O	MFP6	UART1 data transmitter output pin.

	Pin Name	Type	MFP	Description
	UART5_nRTS	O	MFP7	UART5 request to Send output pin.
	USCI1_DAT1	I/O	MFP8	USCI1 data 1 pin.
	SC0_RST	O	MFP9	Smart Card 0 reset pin.
	I2S0_DI	I	MFP10	I ² S0 data input pin.
	EPWM0_CH2	I/O	MFP11	EPWM0 channel 2 output/capture input.
	TM2	I/O	MFP14	Timer2 event counter input/toggle output pin.
	INT2	I	MFP15	External interrupt 2 input pin.
PB.4	PB.4	I/O	MFP0	General purpose digital I/O pin.
	EADC0_CH4	A	MFP1	EADC0 channel 4 analog input.
	ACMP1_P1	A	MFP1	Analog comparator 1 positive input 1 pin.
	EBI_ADR1	O	MFP2	EBI address bus bit 1.
	SD0_DAT2	I/O	MFP3	SD/SDIO0 data line bit 2.
	EMAC_RMII_RXD0	I	MFP4	EMAC RMII Receive Data bus bit 0.
	SPI1_MOSI	I/O	MFP5	SPI1 MOSI (Master Out, Slave In) pin.
	I2C0_SDA	I/O	MFP6	I ² C0 data input/output pin.
	UART5_RXD	I	MFP7	UART5 data receiver input pin.
	USCI1_CTL1	I/O	MFP8	USCI1 control 1 pin.
	SC0_DAT	I/O	MFP9	Smart Card 0 data pin.
	I2S0_MCLK	O	MFP10	I ² S0 master clock output pin.
	EPWM0_CH1	I/O	MFP11	EPWM0 channel 1 output/capture input.
	TM1	I/O	MFP14	Timer1 event counter input/toggle output pin.
INT1	I	MFP15	External interrupt 1 input pin.	
PB.5	PB.5	I/O	MFP0	General purpose digital I/O pin.
	EADC0_CH5	A	MFP1	EADC0 channel 5 analog input.
	ACMP1_N	A	MFP1	Analog comparator 1 negative input pin.
	EBI_ADR0	O	MFP2	EBI address bus bit 0.
	SD0_DAT3	I/O	MFP3	SD/SDIO0 data line bit 3.
	EMAC_RMII_REFCLK	I	MFP4	EMAC RMII reference clock input pin.
	SPI1_MISO	I/O	MFP5	SPI1 MISO (Master In, Slave Out) pin.
	I2C0_SCL	I/O	MFP6	I ² C0 clock pin.
	UART5_TXD	O	MFP7	UART5 data transmitter output pin.
	USCI1_CTL0	I/O	MFP8	USCI1 control 0 pin.
	SC0_CLK	O	MFP9	Smart Card 0 clock pin.
	I2S0_BCLK	O	MFP10	I ² S0 bit clock output pin.

	Pin Name	Type	MFP	Description
	EPWM0_CH0	I/O	MFP11	EPWM0 channel 0 output/capture input.
	TM0	I/O	MFP14	Timer0 event counter input/toggle output pin.
	INT0	I	MFP15	External interrupt 0 input pin.
PB.6	PB.6	I/O	MFP0	General purpose digital I/O pin.
	EADC0_CH6	A	MFP1	EADC0 channel 6 analog input.
	EBI_nWRH	O	MFP2	EBI high byte write enable output pin
	EMAC_PPS	O	MFP3	EMAC Pulse Per Second output pin.
	USCI1_DAT1	I/O	MFP4	USCI1 data 1 pin.
	CAN1_RXD	I	MFP5	CAN1 bus receiver input.
	UART1_RXD	I	MFP6	UART1 data receiver input pin.
	SD1_CLK	O	MFP7	SD/SDIO1 clock output pin
	EBI_nCS1	O	MFP8	EBI chip select 1 output pin.
	BPWM1_CH5	I/O	MFP10	BPWM1 channel 5 output/capture input.
	EPWM1_BRAKE1	I	MFP11	EPWM1 Brake 1 input pin.
	EPWM1_CH5	I/O	MFP12	EPWM1 channel 5 output/capture input.
	INT4	I	MFP13	External interrupt 4 input pin.
	USB_VBUS_EN	O	MFP14	USB external VBUS regulator enable pin.
	ACMP1_O	O	MFP15	Analog comparator 1 output pin.
PB.7	PB.7	I/O	MFP0	General purpose digital I/O pin.
	EADC0_CH7	A	MFP1	EADC0 channel 7 analog input.
	EBI_nWRL	O	MFP2	EBI low byte write enable output pin.
	EMAC_RMII_TXEN	O	MFP3	EMAC RMII Transmit Enable output pin.
	USCI1_DAT0	I/O	MFP4	USCI1 data 0 pin.
	CAN1_TXD	O	MFP5	CAN1 bus transmitter output.
	UART1_TXD	O	MFP6	UART1 data transmitter output pin.
	SD1_CMD	I/O	MFP7	SD/SDIO1 command/response pin
	EBI_nCS0	O	MFP8	EBI chip select 0 output pin.
	BPWM1_CH4	I/O	MFP10	BPWM1 channel 4 output/capture input.
	EPWM1_BRAKE0	I	MFP11	EPWM1 Brake 0 input pin.
	EPWM1_CH4	I/O	MFP12	EPWM1 channel 4 output/capture input.
	INT5	I	MFP13	External interrupt 5 input pin.
	USB_VBUS_ST	I	MFP14	USB external VBUS regulator status pin.
ACMP0_O	O	MFP15	Analog comparator 0 output pin.	
PB.8	PB.8	I/O	MFP0	General purpose digital I/O pin.

	Pin Name	Type	MFP	Description
	EADC0_CH8	A	MFP1	EADC0 channel 8 analog input.
	EBI_ADR19	O	MFP2	EBI address bus bit 19.
	EMAC_RMII_TXD1	O	MFP3	EMAC RMII Transmit Data bus bit 1.
	USCI1_CLK	I/O	MFP4	USCI1 clock pin.
	UART0_RXD	I	MFP5	UART0 data receiver input pin.
	UART1_nRTS	O	MFP6	UART1 request to Send output pin.
	I2C1_SMBSUS	O	MFP7	I ² C1 SMBus SMBSUS pin (PMBus CONTROL pin)
	BPWM1_CH3	I/O	MFP10	BPWM1 channel 3 output/capture input.
	SPI3_MOSI	I/O	MFP11	SPI3 MOSI (Master Out, Slave In) pin.
	INT6	I	MFP13	External interrupt 6 input pin.
PB.9	PB.9	I/O	MFP0	General purpose digital I/O pin.
	EADC0_CH9	A	MFP1	EADC0 channel 9 analog input.
	EBI_ADR18	O	MFP2	EBI address bus bit 18.
	EMAC_RMII_TXD0	O	MFP3	EMAC RMII Transmit Data bus bit 0.
	USCI1_CTL1	I/O	MFP4	USCI1 control 1 pin.
	UART0_TXD	O	MFP5	UART0 data transmitter output pin.
	UART1_nCTS	I	MFP6	UART1 clear to Send input pin.
	I2C1_SMBAL	O	MFP7	I ² C1 SMBus SMBALTER pin
	BPWM1_CH2	I/O	MFP10	BPWM1 channel 2 output/capture input.
	SPI3_MISO	I/O	MFP11	SPI3 MISO (Master In, Slave Out) pin.
	INT7	I	MFP13	External interrupt 7 input pin.
PB.10	PB.10	I/O	MFP0	General purpose digital I/O pin.
	EADC0_CH10	A	MFP1	EADC0 channel 10 analog input.
	EBI_ADR17	O	MFP2	EBI address bus bit 17.
	EMAC_RMII_MDIO	I/O	MFP3	EMAC RMII PHY Management Data pin.
	USCI1_CTL0	I/O	MFP4	USCI1 control 0 pin.
	UART0_nRTS	O	MFP5	UART0 request to Send output pin.
	UART4_RXD	I	MFP6	UART4 data receiver input pin.
	I2C1_SDA	I/O	MFP7	I ² C1 data input/output pin.
	CAN0_RXD	I	MFP8	CAN0 bus receiver input.
	BPWM1_CH1	I/O	MFP10	BPWM1 channel 1 output/capture input.
	SPI3_SS	I/O	MFP11	SPI3 slave select pin.
	HSUSB_VBUS_EN	O	MFP14	HSUSB external VBUS regulator enable pin.
PB.11	PB.11	I/O	MFP0	General purpose digital I/O pin.

	Pin Name	Type	MFP	Description
	EADC0_CH11	A	MFP1	EADC0 channel 11 analog input.
	EBI_ADR16	O	MFP2	EBI address bus bit 16.
	EMAC_RMII_MDC	O	MFP3	EMAC RMII PHY Management Clock output pin.
	UART0_nCTS	I	MFP5	UART0 clear to Send input pin.
	UART4_TXD	O	MFP6	UART4 data transmitter output pin.
	I2C1_SCL	I/O	MFP7	I ² C1 clock pin.
	CAN0_TXD	O	MFP8	CAN0 bus transmitter output.
	SPI0_I2SMCLK	I/O	MFP9	SPI0 I ² S master clock output pin
	BPWM1_CH0	I/O	MFP10	BPWM1 channel 0 output/capture input.
	SPI3_CLK	I/O	MFP11	SPI3 serial clock pin.
	HSUSB_VBUS_ST	I	MFP14	HSUSB external VBUS regulator status pin.
PB.12	PB.12	I/O	MFP0	General purpose digital I/O pin.
	EADC0_CH12	A	MFP1	EADC0 channel 12 analog input.
	DAC0_OUT	A	MFP1	DAC0 channel analog output.
	ACMP0_P2	A	MFP1	Analog comparator 0 positive input 2 pin.
	ACMP1_P2	A	MFP1	Analog comparator 1 positive input 2 pin.
	EBI_AD15	I/O	MFP2	EBI address/data bus bit 15.
	SC1_CLK	O	MFP3	Smart Card 1 clock pin.
	SPI0_MOSI	I/O	MFP4	SPI0 MOSI (Master Out, Slave In) pin.
	USCI0_CLK	I/O	MFP5	USCI0 clock pin.
	UART0_RXD	I	MFP6	UART0 data receiver input pin.
	UART3_nCTS	I	MFP7	UART3 clear to Send input pin.
	I2C2_SDA	I/O	MFP8	I ² C2 data input/output pin.
	SD0_nCD	I	MFP9	SD/SDIO0 card detect input pin
	EPWM1_CH3	I/O	MFP11	EPWM1 channel 3 output/capture input.
TM3_EXT	I/O	MFP13	Timer3 external capture input/toggle output pin.	
PB.13	PB.13	I/O	MFP0	General purpose digital I/O pin.
	EADC0_CH13	A	MFP1	EADC0 channel 13 analog input.
	DAC1_OUT	A	MFP1	DAC1 channel analog output.
	ACMP0_P3	A	MFP1	Analog comparator 0 positive input 3 pin.
	ACMP1_P3	A	MFP1	Analog comparator 1 positive input 3 pin.
	EBI_AD14	I/O	MFP2	EBI address/data bus bit 14.
	SC1_DAT	I/O	MFP3	Smart Card 1 data pin.
	SPI0_MISO	I/O	MFP4	SPI0 MISO (Master In, Slave Out) pin.

	Pin Name	Type	MFP	Description
	USCI0_DAT0	I/O	MFP5	USCI0 data 0 pin.
	UART0_TXD	O	MFP6	UART0 data transmitter output pin.
	UART3_nRTS	O	MFP7	UART3 request to Send output pin.
	I2C2_SCL	I/O	MFP8	I ² C2 clock pin.
	EPWM1_CH2	I/O	MFP11	EPWM1 channel 2 output/capture input.
	TM2_EXT	I/O	MFP13	Timer2 external capture input/toggle output pin.
PB.14	PB.14	I/O	MFP0	General purpose digital I/O pin.
	EADC0_CH14	A	MFP1	EADC0 channel 14 analog input.
	EBI_AD13	I/O	MFP2	EBI address/data bus bit 13.
	SC1_RST	O	MFP3	Smart Card 1 reset pin.
	SPI0_CLK	I/O	MFP4	SPI0 serial clock pin.
	USCI0_DAT1	I/O	MFP5	USCI0 data 1 pin.
	UART0_nRTS	O	MFP6	UART0 request to Send output pin.
	UART3_RXD	I	MFP7	UART3 data receiver input pin.
	I2C2_SMBSUS	O	MFP8	I ² C2 SMBus SMBSUS pin (PMBus CONTROL pin)
	EPWM1_CH1	I/O	MFP11	EPWM1 channel 1 output/capture input.
	TM1_EXT	I/O	MFP13	Timer1 external capture input/toggle output pin.
	CLKO	O	MFP14	Clock Out
PB.15	PB.15	I/O	MFP0	General purpose digital I/O pin.
	EADC0_CH15	A	MFP1	EADC0 channel 15 analog input.
	EBI_AD12	I/O	MFP2	EBI address/data bus bit 12.
	SC1_PWR	O	MFP3	Smart Card 1 power pin.
	SPI0_SS	I/O	MFP4	SPI0 slave select pin.
	USCI0_CTL1	I/O	MFP5	USCI0 control 1 pin.
	UART0_nCTS	I	MFP6	UART0 clear to Send input pin.
	UART3_TXD	O	MFP7	UART3 data transmitter output pin.
	I2C2_SMBAL	O	MFP8	I ² C2 SMBus SMBALTER pin
	EPWM1_CH0	I/O	MFP11	EPWM1 channel 0 output/capture input.
	TM0_EXT	I/O	MFP13	Timer0 external capture input/toggle output pin.
	USB_VBUS_EN	O	MFP14	USB external VBUS regulator enable pin.
	HSUSB_VBUS_EN	O	MFP15	HSUSB external VBUS regulator enable pin.
	PC.0	PC.0	I/O	MFP0
EBI_AD0		I/O	MFP2	EBI address/data bus bit 0.
SPIM_MOSI		I/O	MFP3	SPIM MOSI (Master Out, Slave In) pin.

	Pin Name	Type	MFP	Description
	QSPI0_MOSI0	I/O	MFP4	Quad SPI0 MOSI0 (Master Out, Slave In) pin.
	SC1_CLK	O	MFP5	Smart Card 1 clock pin.
	I2S0_LRCK	O	MFP6	I ² S0 left right channel clock output pin.
	SPI1_SS	I/O	MFP7	SPI1 slave select pin.
	UART2_RXD	I	MFP8	UART2 data receiver input pin.
	I2C0_SDA	I/O	MFP9	I ² C0 data input/output pin.
	EPWM1_CH5	I/O	MFP12	EPWM1 channel 5 output/capture input.
	ACMP1_O	O	MFP14	Analog comparator 1 output pin.
PC.1	PC.1	I/O	MFP0	General purpose digital I/O pin.
	EBI_AD1	I/O	MFP2	EBI address/data bus bit 1.
	SPIM_MISO	I/O	MFP3	SPIM MISO (Master In, Slave Out) pin.
	QSPI0_MISO0	I/O	MFP4	Quad SPI0 MISO0 (Master In, Slave Out) pin.
	SC1_DAT	I/O	MFP5	Smart Card 1 data pin.
	I2S0_DO	O	MFP6	I ² S0 data output pin.
	SPI1_CLK	I/O	MFP7	SPI1 serial clock pin.
	UART2_TXD	O	MFP8	UART2 data transmitter output pin.
	I2C0_SCL	I/O	MFP9	I ² C0 clock pin.
	EPWM1_CH4	I/O	MFP12	EPWM1 channel 4 output/capture input.
	ACMP0_O	O	MFP14	Analog comparator 0 output pin.
PC.2	PC.2	I/O	MFP0	General purpose digital I/O pin.
	EBI_AD2	I/O	MFP2	EBI address/data bus bit 2.
	SPIM_CLK	I/O	MFP3	SPIM serial clock pin.
	QSPI0_CLK	I/O	MFP4	Quad SPI0 serial clock pin.
	SC1_RST	O	MFP5	Smart Card 1 reset pin.
	I2S0_DI	I	MFP6	I ² S0 data input pin.
	SPI1_MOSI	I/O	MFP7	SPI1 MOSI (Master Out, Slave In) pin.
	UART2_nCTS	I	MFP8	UART2 clear to Send input pin.
	I2C0_SMBSUS	O	MFP9	I ² C0 SMBus SMBSUS pin (PMBus CONTROL pin)
	CAN1_RXD	I	MFP10	CAN1 bus receiver input.
	UART3_RXD	I	MFP11	UART3 data receiver input pin.
EPWM1_CH3	I/O	MFP12	EPWM1 channel 3 output/capture input.	
PC.3	PC.3	I/O	MFP0	General purpose digital I/O pin.
	EBI_AD3	I/O	MFP2	EBI address/data bus bit 3.
	SPIM_SS	I/O	MFP3	SPIM slave select pin.

	Pin Name	Type	MFP	Description
	QSPI0_SS	I/O	MFP4	Quad SPI0 slave select pin.
	SC1_PWR	O	MFP5	Smart Card 1 power pin.
	I2S0_MCLK	O	MFP6	I ² S0 master clock output pin.
	SPI1_MISO	I/O	MFP7	SPI1 MISO (Master In, Slave Out) pin.
	UART2_nRTS	O	MFP8	UART2 request to Send output pin.
	I2C0_SMBAL	O	MFP9	I ² C0 SMBus SMBALTER pin
	CAN1_TXD	O	MFP10	CAN1 bus transmitter output.
	UART3_TXD	O	MFP11	UART3 data transmitter output pin.
	EPWM1_CH2	I/O	MFP12	EPWM1 channel 2 output/capture input.
PC.4	PC.4	I/O	MFP0	General purpose digital I/O pin.
	EBI_AD4	I/O	MFP2	EBI address/data bus bit 4.
	SPIM_D3	I/O	MFP3	SPIM data 3 pin for Quad Mode I/O.
	QSPI0_MOSI1	I/O	MFP4	Quad SPI0 MOSI1 (Master Out, Slave In) pin.
	SC1_nCD	I	MFP5	Smart Card 1 card detect pin.
	I2S0_BCLK	O	MFP6	I ² S0 bit clock output pin.
	SPI1_I2SMCLK	I/O	MFP7	SPI1 I ² S master clock output pin
	UART2_RXD	I	MFP8	UART2 data receiver input pin.
	I2C1_SDA	I/O	MFP9	I ² C1 data input/output pin.
	CAN0_RXD	I	MFP10	CAN0 bus receiver input.
	UART4_RXD	I	MFP11	UART4 data receiver input pin.
	EPWM1_CH1	I/O	MFP12	EPWM1 channel 1 output/capture input.
PC.5	PC.5	I/O	MFP0	General purpose digital I/O pin.
	EBI_AD5	I/O	MFP2	EBI address/data bus bit 5.
	SPIM_D2	I/O	MFP3	SPIM data 2 pin for Quad Mode I/O.
	QSPI0_MISO1	I/O	MFP4	Quad SPI0 MISO1 (Master In, Slave Out) pin.
	UART2_TXD	O	MFP8	UART2 data transmitter output pin.
	I2C1_SCL	I/O	MFP9	I ² C1 clock pin.
	CAN0_TXD	O	MFP10	CAN0 bus transmitter output.
	UART4_TXD	O	MFP11	UART4 data transmitter output pin.
	EPWM1_CH0	I/O	MFP12	EPWM1 channel 0 output/capture input.
PC.6	PC.6	I/O	MFP0	General purpose digital I/O pin.
	EBI_AD8	I/O	MFP2	EBI address/data bus bit 8.
	EMAC_RMII_RXD1	I	MFP3	EMAC RMII Receive Data bus bit 1.
	SPI1_MOSI	I/O	MFP4	SPI1 MOSI (Master Out, Slave In) pin.

	Pin Name	Type	MFP	Description
	UART4_RXD	I	MFP5	UART4 data receiver input pin.
	SC2_RST	O	MFP6	Smart Card 2 reset pin.
	UART0_nRTS	O	MFP7	UART0 request to Send output pin.
	I2C1_SMBSUS	O	MFP8	I ² C1 SMBus SMBSUS pin (PMBus CONTROL pin)
	EPWM1_CH3	I/O	MFP11	EPWM1 channel 3 output/capture input.
	BPWM1_CH1	I/O	MFP12	BPWM1 channel 1 output/capture input.
	TM1	I/O	MFP14	Timer1 event counter input/toggle output pin.
	INT2	I	MFP15	External interrupt 2 input pin.
PC.7	PC.7	I/O	MFP0	General purpose digital I/O pin.
	EBI_AD9	I/O	MFP2	EBI address/data bus bit 9.
	EMAC_RMII_RXD0	I	MFP3	EMAC RMII Receive Data bus bit 0.
	SPI1_MISO	I/O	MFP4	SPI1 MISO (Master In, Slave Out) pin.
	UART4_TXD	O	MFP5	UART4 data transmitter output pin.
	SC2_PWR	O	MFP6	Smart Card 2 power pin.
	UART0_nCTS	I	MFP7	UART0 clear to Send input pin.
	I2C1_SMBAL	O	MFP8	I ² C1 SMBus SMBALTER pin
	EPWM1_CH2	I/O	MFP11	EPWM1 channel 2 output/capture input.
	BPWM1_CH0	I/O	MFP12	BPWM1 channel 0 output/capture input.
	TM0	I/O	MFP14	Timer0 event counter input/toggle output pin.
	INT3	I	MFP15	External interrupt 3 input pin.
PC.8	PC.8	I/O	MFP0	General purpose digital I/O pin.
	EBI_ADR16	O	MFP2	EBI address bus bit 16.
	EMAC_RMII_REFCLK	I	MFP3	EMAC RMII reference clock input pin.
	I2C0_SDA	I/O	MFP4	I ² C0 data input/output pin.
	UART4_nCTS	I	MFP5	UART4 clear to Send input pin.
	UART1_RXD	I	MFP8	UART1 data receiver input pin.
	EPWM1_CH1	I/O	MFP11	EPWM1 channel 1 output/capture input.
	BPWM1_CH4	I/O	MFP12	BPWM1 channel 4 output/capture input.
PC.9	PC.9	I/O	MFP0	General purpose digital I/O pin.
	EBI_ADR7	O	MFP2	EBI address bus bit 7.
	SPI3_SS	I/O	MFP6	SPI3 slave select pin.
	UART3_RXD	I	MFP7	UART3 data receiver input pin.
	CAN1_RXD	I	MFP9	CAN1 bus receiver input.
	EPWM1_CH3	I/O	MFP12	EPWM1 channel 3 output/capture input.

	Pin Name	Type	MFP	Description
PC.10	PC.10	I/O	MFP0	General purpose digital I/O pin.
	EBI_ADR6	O	MFP2	EBI address bus bit 6.
	SPI3_CLK	I/O	MFP6	SPI3 serial clock pin.
	UART3_TXD	O	MFP7	UART3 data transmitter output pin.
	CAN1_TXD	O	MFP9	CAN1 bus transmitter output.
	ECAP1_IC0	I	MFP11	Enhanced capture unit 1 input 0 pin.
	EPWM1_CH2	I/O	MFP12	EPWM1 channel 2 output/capture input.
PC.11	PC.11	I/O	MFP0	General purpose digital I/O pin.
	EBI_ADR5	O	MFP2	EBI address bus bit 5.
	UART0_RXD	I	MFP3	UART0 data receiver input pin.
	I2C0_SDA	I/O	MFP4	I ² C0 data input/output pin.
	SPI3_MOSI	I/O	MFP6	SPI3 MOSI (Master Out, Slave In) pin.
	ECAP1_IC1	I	MFP11	Enhanced capture unit 1 input 1 pin.
	EPWM1_CH1	I/O	MFP12	EPWM1 channel 1 output/capture input.
	ACMP1_O	O	MFP14	Analog comparator 1 output pin.
PC.12	PC.12	I/O	MFP0	General purpose digital I/O pin.
	EBI_ADR4	O	MFP2	EBI address bus bit 4.
	UART0_TXD	O	MFP3	UART0 data transmitter output pin.
	I2C0_SCL	I/O	MFP4	I ² C0 clock pin.
	SPI3_MISO	I/O	MFP6	SPI3 MISO (Master In, Slave Out) pin.
	SC0_nCD	I	MFP9	Smart Card 0 card detect pin.
	ECAP1_IC2	I	MFP11	Enhanced capture unit 1 input 2 pin.
	EPWM1_CH0	I/O	MFP12	EPWM1 channel 0 output/capture input.
	ACMP0_O	O	MFP14	Analog comparator 0 output pin.
PC.13	PC.13	I/O	MFP0	General purpose digital I/O pin.
	EBI_ADR10	O	MFP2	EBI address bus bit 10.
	SC2_nCD	I	MFP3	Smart Card 2 card detect pin.
	SPI2_I2SMCLK	I/O	MFP4	SPI2 I ² S master clock output pin
	CAN1_TXD	O	MFP5	CAN1 bus transmitter output.
	USCI0_CTL0	I/O	MFP6	USCI0 control 0 pin.
	UART2_TXD	O	MFP7	UART2 data transmitter output pin.
	BPWM0_CH4	I/O	MFP9	BPWM0 channel 4 output/capture input.
	CLKO	O	MFP13	Clock Out
	EADC0_ST	I	MFP14	EADC0 external trigger input.

	Pin Name	Type	MFP	Description
PC.14	PC.14	I/O	MFP0	General purpose digital I/O pin.
	EBI_AD11	I/O	MFP2	EBI address/data bus bit 11.
	SC1_nCD	I	MFP3	Smart Card 1 card detect pin.
	SPI0_I2SMCLK	I/O	MFP4	SPI0 I ² S master clock output pin
	USCI0_CTL0	I/O	MFP5	USCI0 control 0 pin.
	QSPI0_CLK	I/O	MFP6	Quad SPI0 serial clock pin.
	EPWM0_SYNC_IN	I	MFP11	EPWM0 counter synchronous trigger input pin.
	TM1	I/O	MFP13	Timer1 event counter input/toggle output pin.
	USB_VBUS_ST	I	MFP14	USB external VBUS regulator status pin.
	HSUSB_VBUS_ST	I	MFP15	HSUSB external VBUS regulator status pin.
PD.0	PD.0	I/O	MFP0	General purpose digital I/O pin.
	EBI_AD13	I/O	MFP2	EBI address/data bus bit 13.
	USCI0_CLK	I/O	MFP3	USCI0 clock pin.
	SPI0_MOSI	I/O	MFP4	SPI0 MOSI (Master Out, Slave In) pin.
	UART3_RXD	I	MFP5	UART3 data receiver input pin.
	I2C2_SDA	I/O	MFP6	I ² C2 data input/output pin.
	SC2_CLK	O	MFP7	Smart Card 2 clock pin.
	TM2	I/O	MFP14	Timer2 event counter input/toggle output pin.
PD.1	PD.1	I/O	MFP0	General purpose digital I/O pin.
	EBI_AD12	I/O	MFP2	EBI address/data bus bit 12.
	USCI0_DAT0	I/O	MFP3	USCI0 data 0 pin.
	SPI0_MISO	I/O	MFP4	SPI0 MISO (Master In, Slave Out) pin.
	UART3_TXD	O	MFP5	UART3 data transmitter output pin.
	I2C2_SCL	I/O	MFP6	I ² C2 clock pin.
	SC2_DAT	I/O	MFP7	Smart Card 2 data pin.
PD.2	PD.2	I/O	MFP0	General purpose digital I/O pin.
	EBI_AD11	I/O	MFP2	EBI address/data bus bit 11.
	USCI0_DAT1	I/O	MFP3	USCI0 data 1 pin.
	SPI0_CLK	I/O	MFP4	SPI0 serial clock pin.
	UART3_nCTS	I	MFP5	UART3 clear to Send input pin.
	SC2_RST	O	MFP7	Smart Card 2 reset pin.
	UART0_RXD	I	MFP9	UART0 data receiver input pin.
PD.3	PD.3	I/O	MFP0	General purpose digital I/O pin.
	EBI_AD10	I/O	MFP2	EBI address/data bus bit 10.

	Pin Name	Type	MFP	Description
	USCI0_CTL1	I/O	MFP3	USCI0 control 1 pin.
	SPI0_SS	I/O	MFP4	SPI0 slave select pin.
	UART3_nRTS	O	MFP5	UART3 request to Send output pin.
	USCI1_CTL0	I/O	MFP6	USCI1 control 0 pin.
	SC2_PWR	O	MFP7	Smart Card 2 power pin.
	SC1_nCD	I	MFP8	Smart Card 1 card detect pin.
	UART0_TXD	O	MFP9	UART0 data transmitter output pin.
PD.4	PD.4	I/O	MFP0	General purpose digital I/O pin.
	USCI0_CTL0	I/O	MFP3	USCI0 control 0 pin.
	I2C1_SDA	I/O	MFP4	I ² C1 data input/output pin.
	SPI1_SS	I/O	MFP5	SPI1 slave select pin.
	USCI1_CTL1	I/O	MFP6	USCI1 control 1 pin.
	SC1_CLK	O	MFP8	Smart Card 1 clock pin.
	USB_VBUS_ST	I	MFP14	USB external VBUS regulator status pin.
PD.5	PD.5	I/O	MFP0	General purpose digital I/O pin.
	I2C1_SCL	I/O	MFP4	I ² C1 clock pin.
	SPI1_CLK	I/O	MFP5	SPI1 serial clock pin.
	USCI1_DAT0	I/O	MFP6	USCI1 data 0 pin.
	SC1_DAT	I/O	MFP8	Smart Card 1 data pin.
PD.6	PD.6	I/O	MFP0	General purpose digital I/O pin.
	UART1_RXD	I	MFP3	UART1 data receiver input pin.
	I2C0_SDA	I/O	MFP4	I ² C0 data input/output pin.
	SPI1_MOSI	I/O	MFP5	SPI1 MOSI (Master Out, Slave In) pin.
	USCI1_DAT1	I/O	MFP6	USCI1 data 1 pin.
	SC1_RST	O	MFP8	Smart Card 1 reset pin.
PD.7	PD.7	I/O	MFP0	General purpose digital I/O pin.
	UART1_TXD	O	MFP3	UART1 data transmitter output pin.
	I2C0_SCL	I/O	MFP4	I ² C0 clock pin.
	SPI1_MISO	I/O	MFP5	SPI1 MISO (Master In, Slave Out) pin.
	USCI1_CLK	I/O	MFP6	USCI1 clock pin.
	SC1_PWR	O	MFP8	Smart Card 1 power pin.
PD.8	PD.8	I/O	MFP0	General purpose digital I/O pin.
	EBI_AD6	I/O	MFP2	EBI address/data bus bit 6.
	I2C2_SDA	I/O	MFP3	I ² C2 data input/output pin.

	Pin Name	Type	MFP	Description
	UART2_nRTS	O	MFP4	UART2 request to Send output pin.
PD.9	PD.9	I/O	MFP0	General purpose digital I/O pin.
	EBI_AD7	I/O	MFP2	EBI address/data bus bit 7.
	I2C2_SCL	I/O	MFP3	I ² C2 clock pin.
	UART2_nCTS	I	MFP4	UART2 clear to Send input pin.
PD.10	PD.10	I/O	MFP0	General purpose digital I/O pin.
	OPA2_P	A	MFP1	Operational amplifier 2 positive input pin.
	EBI_nCS2	O	MFP2	EBI chip select 2 output pin.
	UART1_RXD	I	MFP3	UART1 data receiver input pin.
	CAN0_RXD	I	MFP4	CAN0 bus receiver input.
	QEIO_B	I	MFP10	Quadrature encoder 0 phase B input
	INT7	I	MFP15	External interrupt 7 input pin.
PD.11	PD.11	I/O	MFP0	General purpose digital I/O pin.
	OPA2_N	A	MFP1	Operational amplifier 2 negative input pin.
	EBI_nCS1	O	MFP2	EBI chip select 1 output pin.
	UART1_TXD	O	MFP3	UART1 data transmitter output pin.
	CAN0_TXD	O	MFP4	CAN0 bus transmitter output.
	QEIO_A	I	MFP10	Quadrature encoder 0 phase A input
	INT6	I	MFP15	External interrupt 6 input pin.
PD.12	PD.12	I/O	MFP0	General purpose digital I/O pin.
	OPA2_O	A	MFP1	Operational amplifier 2 output pin.
	EBI_nCS0	O	MFP2	EBI chip select 0 output pin.
	CAN1_RXD	I	MFP5	CAN1 bus receiver input.
	UART2_RXD	I	MFP7	UART2 data receiver input pin.
	BPWM0_CH5	I/O	MFP9	BPWM0 channel 5 output/capture input.
	QEIO_INDEX	I	MFP10	Quadrature encoder 0 index input
	CLKO	O	MFP13	Clock Out
	EADC0_ST	I	MFP14	EADC0 external trigger input.
	INT5	I	MFP15	External interrupt 5 input pin.
PD.13	PD.13	I/O	MFP0	General purpose digital I/O pin.
	EBI_AD10	I/O	MFP2	EBI address/data bus bit 10.
	SD0_nCD	I	MFP3	SD/SDIO0 card detect input pin
	SPI0_I2SMCLK	I/O	MFP4	SPI0 I ² S master clock output pin
	SPI1_I2SMCLK	I/O	MFP5	SPI1 I ² S master clock output pin

	Pin Name	Type	MFP	Description
	SC2_nCD	I	MFP7	Smart Card 2 card detect pin.
PD.14	PD.14	I/O	MFP0	General purpose digital I/O pin.
	EBI_nCS0	O	MFP2	EBI chip select 0 output pin.
	SPI3_I2SMCLK	I/O	MFP3	SPI3 I ² S master clock output pin
	SC1_nCD	I	MFP4	Smart Card 1 card detect pin.
	EPWM0_CH4	I/O	MFP11	EPWM0 channel 4 output/capture input.
PE.0	PE.0	I/O	MFP0	General purpose digital I/O pin.
	EBI_AD11	I/O	MFP2	EBI address/data bus bit 11.
	QSPI0_MOSI0	I/O	MFP3	Quad SPI0 MOSI0 (Master Out, Slave In) pin.
	SC2_CLK	O	MFP4	Smart Card 2 clock pin.
	I2S0_MCLK	O	MFP5	I ² S0 master clock output pin.
	SPI1_MOSI	I/O	MFP6	SPI1 MOSI (Master Out, Slave In) pin.
	UART3_RXD	I	MFP7	UART3 data receiver input pin.
	I2C1_SDA	I/O	MFP8	I ² C1 data input/output pin.
	UART4_nRTS	O	MFP9	UART4 request to Send output pin.
PE.1	PE.1	I/O	MFP0	General purpose digital I/O pin.
	EBI_AD10	I/O	MFP2	EBI address/data bus bit 10.
	QSPI0_MISO0	I/O	MFP3	Quad SPI0 MISO0 (Master In, Slave Out) pin.
	SC2_DAT	I/O	MFP4	Smart Card 2 data pin.
	I2S0_BCLK	O	MFP5	I ² S0 bit clock output pin.
	SPI1_MISO	I/O	MFP6	SPI1 MISO (Master In, Slave Out) pin.
	UART3_TXD	O	MFP7	UART3 data transmitter output pin.
	I2C1_SCL	I/O	MFP8	I ² C1 clock pin.
	UART4_nCTS	I	MFP9	UART4 clear to Send input pin.
PE.2	PE.2	I/O	MFP0	General purpose digital I/O pin.
	EBI_ALE	O	MFP2	EBI address latch enable output pin.
	SD0_DAT0	I/O	MFP3	SD/SDIO0 data line bit 0.
	SPIM_MOSI	I/O	MFP4	SPIM MOSI (Master Out, Slave In) pin.
	SPI3_MOSI	I/O	MFP5	SPI3 MOSI (Master Out, Slave In) pin.
	SC0_CLK	O	MFP6	Smart Card 0 clock pin.
	USCI0_CLK	I/O	MFP7	USCI0 clock pin.
	QEI0_B	I	MFP11	Quadrature encoder 0 phase B input
	EPWM0_CH5	I/O	MFP12	EPWM0 channel 5 output/capture input.
	BPWM0_CH0	I/O	MFP13	BPWM0 channel 0 output/capture input.

	Pin Name	Type	MFP	Description
PE.3	PE.3	I/O	MFP0	General purpose digital I/O pin.
	EBI_MCLK	O	MFP2	EBI external clock output pin.
	SD0_DAT1	I/O	MFP3	SD/SDIO0 data line bit 1.
	SPIM_MISO	I/O	MFP4	SPIM MISO (Master In, Slave Out) pin.
	SPI3_MISO	I/O	MFP5	SPI3 MISO (Master In, Slave Out) pin.
	SC0_DAT	I/O	MFP6	Smart Card 0 data pin.
	USCI0_DAT0	I/O	MFP7	USCI0 data 0 pin.
	QEIO_A	I	MFP11	Quadrature encoder 0 phase A input
	EPWM0_CH4	I/O	MFP12	EPWM0 channel 4 output/capture input.
	BPWM0_CH1	I/O	MFP13	BPWM0 channel 1 output/capture input.
PE.4	PE.4	I/O	MFP0	General purpose digital I/O pin.
	EBI_nWR	O	MFP2	EBI write enable output pin.
	SD0_DAT2	I/O	MFP3	SD/SDIO0 data line bit 2.
	SPIM_CLK	I/O	MFP4	SPIM serial clock pin.
	SPI3_CLK	I/O	MFP5	SPI3 serial clock pin.
	SC0_RST	O	MFP6	Smart Card 0 reset pin.
	USCI0_DAT1	I/O	MFP7	USCI0 data 1 pin.
	QEIO_INDEX	I	MFP11	Quadrature encoder 0 index input
	EPWM0_CH3	I/O	MFP12	EPWM0 channel 3 output/capture input.
	BPWM0_CH2	I/O	MFP13	BPWM0 channel 2 output/capture input.
PE.5	PE.5	I/O	MFP0	General purpose digital I/O pin.
	EBI_nRD	O	MFP2	EBI read enable output pin.
	SD0_DAT3	I/O	MFP3	SD/SDIO0 data line bit 3.
	SPIM_SS	I/O	MFP4	SPIM slave select pin.
	SPI3_SS	I/O	MFP5	SPI3 slave select pin.
	SC0_PWR	O	MFP6	Smart Card 0 power pin.
	USCI0_CTL1	I/O	MFP7	USCI0 control 1 pin.
	QEIO_B	I	MFP11	Quadrature encoder 1 phase B input
	EPWM0_CH2	I/O	MFP12	EPWM0 channel 2 output/capture input.
	BPWM0_CH3	I/O	MFP13	BPWM0 channel 3 output/capture input.
PE.6	PE.6	I/O	MFP0	General purpose digital I/O pin.
	SD0_CLK	O	MFP3	SD/SDIO0 clock output pin
	SPIM_D3	I/O	MFP4	SPIM data 3 pin for Quad Mode I/O.
	SPI3_I2SMCLK	I/O	MFP5	SPI3 I ² S master clock output pin

	Pin Name	Type	MFP	Description
	SC0_nCD	I	MFP6	Smart Card 0 card detect pin.
	USCI0_CTL0	I/O	MFP7	USCI0 control 0 pin.
	UART5_RXD	I	MFP8	UART5 data receiver input pin.
	CAN1_RXD	I	MFP9	CAN1 bus receiver input.
	QE11_A	I	MFP11	Quadrature encoder 1 phase A input
	EPWM0_CH1	I/O	MFP12	EPWM0 channel 1 output/capture input.
	BPWM0_CH4	I/O	MFP13	BPWM0 channel 4 output/capture input.
PE.7	PE.7	I/O	MFP0	General purpose digital I/O pin.
	SD0_CMD	I/O	MFP3	SD/SDIO0 command/response pin
	SPIM_D2	I/O	MFP4	SPIM data 2 pin for Quad Mode I/O.
	UART5_TXD	O	MFP8	UART5 data transmitter output pin.
	CAN1_TXD	O	MFP9	CAN1 bus transmitter output.
	QE11_INDEX	I	MFP11	Quadrature encoder 1 index input
	EPWM0_CH0	I/O	MFP12	EPWM0 channel 0 output/capture input.
BPWM0_CH5	I/O	MFP13	BPWM0 channel 5 output/capture input.	
PE.8	PE.8	I/O	MFP0	General purpose digital I/O pin.
	EBI_ADR10	O	MFP2	EBI address bus bit 10.
	EMAC_RMII_MDC	O	MFP3	EMAC RMII PHY Management Clock output pin.
	I2S0_BCLK	O	MFP4	I ² S0 bit clock output pin.
	SPI2_CLK	I/O	MFP5	SPI2 serial clock pin.
	USCI1_CTL1	I/O	MFP6	USCI1 control 1 pin.
	UART2_TXD	O	MFP7	UART2 data transmitter output pin.
	EPWM0_CH0	I/O	MFP10	EPWM0 channel 0 output/capture input.
	EPWM0_BRAKE0	I	MFP11	EPWM0 Brake 0 input pin.
	ECAP0_IC0	I	MFP12	Enhanced capture unit 0 input 0 pin.
TRACE_CLK	O	MFP14	ETM Trace Clock output pin	
PE.9	PE.9	I/O	MFP0	General purpose digital I/O pin.
	EBI_ADR11	O	MFP2	EBI address bus bit 11.
	EMAC_RMII_MDIO	I/O	MFP3	EMAC RMII PHY Management Data pin.
	I2S0_MCLK	O	MFP4	I ² S0 master clock output pin.
	SPI2_MISO	I/O	MFP5	SPI2 MISO (Master In, Slave Out) pin.
	USCI1_CTL0	I/O	MFP6	USCI1 control 0 pin.
	UART2_RXD	I	MFP7	UART2 data receiver input pin.
	EPWM0_CH1	I/O	MFP10	EPWM0 channel 1 output/capture input.

	Pin Name	Type	MFP	Description
	EPWM0_BRAKE1	I	MFP11	EPWM0 Brake 1 input pin.
	ECAP0_IC1	I	MFP12	Enhanced capture unit 0 input 1 pin.
	TRACE_DATA0	O	MFP14	ETM Trace Data 0 output pin
PE.10	PE.10	I/O	MFP0	General purpose digital I/O pin.
	EBI_ADR12	O	MFP2	EBI address bus bit 12.
	EMAC_RMII_TXD0	O	MFP3	EMAC RMII Transmit Data bus bit 0.
	I2S0_DI	I	MFP4	I ² S0 data input pin.
	SPI2_MOSI	I/O	MFP5	SPI2 MOSI (Master Out, Slave In) pin.
	USCI1_DAT0	I/O	MFP6	USCI1 data 0 pin.
	UART3_TXD	O	MFP7	UART3 data transmitter output pin.
	EPWM0_CH2	I/O	MFP10	EPWM0 channel 2 output/capture input.
	EPWM1_BRAKE0	I	MFP11	EPWM1 Brake 0 input pin.
	ECAP0_IC2	I	MFP12	Enhanced capture unit 0 input 2 pin.
TRACE_DATA1	O	MFP14	ETM Trace Data 1 output pin	
PE.11	PE.11	I/O	MFP0	General purpose digital I/O pin.
	EBI_ADR13	O	MFP2	EBI address bus bit 13.
	EMAC_RMII_TXD1	O	MFP3	EMAC RMII Transmit Data bus bit 1.
	I2S0_DO	O	MFP4	I ² S0 data output pin.
	SPI2_SS	I/O	MFP5	SPI2 slave select pin.
	USCI1_DAT1	I/O	MFP6	USCI1 data 1 pin.
	UART3_RXD	I	MFP7	UART3 data receiver input pin.
	UART1_nCTS	I	MFP8	UART1 clear to Send input pin.
	EPWM0_CH3	I/O	MFP10	EPWM0 channel 3 output/capture input.
	EPWM1_BRAKE1	I	MFP11	EPWM1 Brake 1 input pin.
	ECAP1_IC2	I	MFP13	Enhanced capture unit 1 input 2 pin.
TRACE_DATA2	O	MFP14	ETM Trace Data 2 output pin	
PE.12	PE.12	I/O	MFP0	General purpose digital I/O pin.
	EBI_ADR14	O	MFP2	EBI address bus bit 14.
	EMAC_RMII_TXEN	O	MFP3	EMAC RMII Transmit Enable output pin.
	I2S0_LRCK	O	MFP4	I ² S0 left right channel clock output pin.
	SPI2_I2SMCLK	I/O	MFP5	SPI2 I ² S master clock output pin
	USCI1_CLK	I/O	MFP6	USCI1 clock pin.
	UART1_nRTS	O	MFP8	UART1 request to Send output pin.
	EPWM0_CH4	I/O	MFP10	EPWM0 channel 4 output/capture input.

	Pin Name	Type	MFP	Description
	ECAP1_IC1	I	MFP13	Enhanced capture unit 1 input 1 pin.
	TRACE_DATA3	O	MFP14	ETM Trace Data 3 output pin
PE.13	PE.13	I/O	MFP0	General purpose digital I/O pin.
	EBI_ADR15	O	MFP2	EBI address bus bit 15.
	EMAC_PPS	O	MFP3	EMAC Pulse Per Second output pin.
	I2C0_SCL	I/O	MFP4	I ² C0 clock pin.
	UART4_nRTS	O	MFP5	UART4 request to Send output pin.
	UART1_TXD	O	MFP8	UART1 data transmitter output pin.
	EPWM0_CH5	I/O	MFP10	EPWM0 channel 5 output/capture input.
	EPWM1_CH0	I/O	MFP11	EPWM1 channel 0 output/capture input.
	BPWM1_CH5	I/O	MFP12	BPWM1 channel 5 output/capture input.
	ECAP1_IC0	I	MFP13	Enhanced capture unit 1 input 0 pin.
PE.14	PE.14	I/O	MFP0	General purpose digital I/O pin.
	EBI_AD8	I/O	MFP2	EBI address/data bus bit 8.
	UART2_TXD	O	MFP3	UART2 data transmitter output pin.
	CAN0_TXD	O	MFP4	CAN0 bus transmitter output.
	SD1_nCD	I	MFP5	SD/SDIO1 card detect input pin
PE.15	PE.15	I/O	MFP0	General purpose digital I/O pin.
	EBI_AD9	I/O	MFP2	EBI address/data bus bit 9.
	UART2_RXD	I	MFP3	UART2 data receiver input pin.
	CAN0_RXD	I	MFP4	CAN0 bus receiver input.
PF.0	PF.0	I/O	MFP0	General purpose digital I/O pin.
	UART1_TXD	O	MFP2	UART1 data transmitter output pin.
	I2C1_SCL	I/O	MFP3	I ² C1 clock pin.
	BPWM1_CH0	I/O	MFP12	BPWM1 channel 0 output/capture input.
	ICE_DAT	O	MFP14	Serial wired debugger data pin.
PF.1	PF.1	I/O	MFP0	General purpose digital I/O pin.
	UART1_RXD	I	MFP2	UART1 data receiver input pin.
	I2C1_SDA	I/O	MFP3	I ² C1 data input/output pin.
	BPWM1_CH1	I/O	MFP12	BPWM1 channel 1 output/capture input.
	ICE_CLK	I	MFP14	Serial wired debugger clock pin.
PF.2	PF.2	I/O	MFP0	General purpose digital I/O pin.
	EBI_nCS1	O	MFP2	EBI chip select 1 output pin.
	UART0_RXD	I	MFP3	UART0 data receiver input pin.

	Pin Name	Type	MFP	Description
	I2C0_SDA	I/O	MFP4	I ² C0 data input/output pin.
	QSPI0_CLK	I/O	MFP5	Quad SPI0 serial clock pin.
	XT1_OUT	O	MFP10	External 4~24 MHz (high speed) crystal output pin.
	BPWM1_CH1	I/O	MFP11	BPWM1 channel 1 output/capture input.
PF.3	PF.3	I/O	MFP0	General purpose digital I/O pin.
	EBI_nCS0	O	MFP2	EBI chip select 0 output pin.
	UART0_TXD	O	MFP3	UART0 data transmitter output pin.
	I2C0_SCL	I/O	MFP4	I ² C0 clock pin.
	XT1_IN	I	MFP10	External 4~24 MHz (high speed) crystal input pin.
	BPWM1_CH0	I/O	MFP11	BPWM1 channel 0 output/capture input.
PF.4	PF.4	I/O	MFP0	General purpose digital I/O pin.
	UART2_TXD	O	MFP2	UART2 data transmitter output pin.
	UART2_nRTS	O	MFP4	UART2 request to Send output pin.
	BPWM0_CH5	I/O	MFP8	BPWM0 channel 5 output/capture input.
	X32_OUT	O	MFP10	External 32.768 kHz crystal output pin.
PF.5	PF.5	I/O	MFP0	General purpose digital I/O pin.
	UART2_RXD	I	MFP2	UART2 data receiver input pin.
	UART2_nCTS	I	MFP4	UART2 clear to Send input pin.
	BPWM0_CH4	I/O	MFP8	BPWM0 channel 4 output/capture input.
	EPWM0_SYNC_OUT	O	MFP9	EPWM0 counter synchronous trigger output pin.
	X32_IN	I	MFP10	External 32.768 kHz crystal input pin.
	EADC0_ST	I	MFP11	EADC0 external trigger input.
PF.6	PF.6	I/O	MFP0	General purpose digital I/O pin.
	EBI_ADR19	O	MFP2	EBI address bus bit 19.
	SC0_CLK	O	MFP3	Smart Card 0 clock pin.
	I2S0_LRCK	O	MFP4	I ² S0 left right channel clock output pin.
	SPI0_MOSI	I/O	MFP5	SPI0 MOSI (Master Out, Slave In) pin.
	UART4_RXD	I	MFP6	UART4 data receiver input pin.
	EBI_nCS0	O	MFP7	EBI chip select 0 output pin.
	TAMPER0	I/O	MFP10	TAMPER detector loop pin 0.
PF.7	PF.7	I/O	MFP0	General purpose digital I/O pin.
	EBI_ADR18	O	MFP2	EBI address bus bit 18.
	SC0_DAT	I/O	MFP3	Smart Card 0 data pin.
	I2S0_DO	O	MFP4	I ² S0 data output pin.

	Pin Name	Type	MFP	Description
	SPI0_MISO	I/O	MFP5	SPI0 MISO (Master In, Slave Out) pin.
	UART4_TXD	O	MFP6	UART4 data transmitter output pin.
	TAMPER1	I/O	MFP10	TAMPER detector loop pin 1.
PF.8	PF.8	I/O	MFP0	General purpose digital I/O pin.
	EBI_ADR17	O	MFP2	EBI address bus bit 17.
	SC0_RST	O	MFP3	Smart Card 0 reset pin.
	I2S0_DI	I	MFP4	I ² S0 data input pin.
	SPI0_CLK	I/O	MFP5	SPI0 serial clock pin.
	TAMPER2	I/O	MFP10	TAMPER detector loop pin 2.
PF.9	PF.9	I/O	MFP0	General purpose digital I/O pin.
	EBI_ADR16	O	MFP2	EBI address bus bit 16.
	SC0_PWR	O	MFP3	Smart Card 0 power pin.
	I2S0_MCLK	O	MFP4	I ² S0 master clock output pin.
	SPI0_SS	I/O	MFP5	SPI0 slave select pin.
	TAMPER3	I/O	MFP10	TAMPER detector loop pin 3.
PF.10	PF.10	I/O	MFP0	General purpose digital I/O pin.
	EBI_ADR15	O	MFP2	EBI address bus bit 15.
	SC0_nCD	I	MFP3	Smart Card 0 card detect pin.
	I2S0_BCLK	O	MFP4	I ² S0 bit clock output pin.
	SPI0_I2SMCLK	I/O	MFP5	SPI0 I ² S master clock output pin
	TAMPER4	I/O	MFP10	TAMPER detector loop pin 4.
PF.11	PF.11	I/O	MFP0	General purpose digital I/O pin.
	EBI_ADR14	O	MFP2	EBI address bus bit 14.
	SPI2_MOSI	I/O	MFP3	SPI2 MOSI (Master Out, Slave In) pin.
	TAMPER5	I/O	MFP10	TAMPER detector loop pin 5.
	TM3	I/O	MFP13	Timer3 event counter input/toggle output pin.
PG.0	PG.0	I/O	MFP0	General purpose digital I/O pin.
	EBI_ADR8	O	MFP2	EBI address bus bit 8.
	I2C0_SCL	I/O	MFP4	I ² C0 clock pin.
	I2C1_SMBAL	O	MFP5	I ² C1 SMBus SMBALTER pin
	UART2_RXD	I	MFP6	UART2 data receiver input pin.
	CAN1_TXD	O	MFP7	CAN1 bus transmitter output.
	UART1_TXD	O	MFP8	UART1 data transmitter output pin.
PG.1	PG.1	I/O	MFP0	General purpose digital I/O pin.

	Pin Name	Type	MFP	Description
	EBI_ADR9	O	MFP2	EBI address bus bit 9.
	SPI2_I2SMCLK	I/O	MFP3	SPI2 I ² S master clock output pin
	I2C0_SDA	I/O	MFP4	I ² C0 data input/output pin.
	I2C1_SMBSUS	O	MFP5	I ² C1 SMBus SMBSUS pin (PMBus CONTROL pin)
	UART2_TXD	O	MFP6	UART2 data transmitter output pin.
	CAN1_RXD	I	MFP7	CAN1 bus receiver input.
	UART1_RXD	I	MFP8	UART1 data receiver input pin.
PG.2	PG.2	I/O	MFP0	General purpose digital I/O pin.
	EBI_ADR11	O	MFP2	EBI address bus bit 11.
	SPI2_SS	I/O	MFP3	SPI2 slave select pin.
	I2C0_SMBAL	O	MFP4	I ² C0 SMBus SMBALTER pin
	I2C1_SCL	I/O	MFP5	I ² C1 clock pin.
	TM0	I/O	MFP13	Timer0 event counter input/toggle output pin.
PG.3	PG.3	I/O	MFP0	General purpose digital I/O pin.
	EBI_ADR12	O	MFP2	EBI address bus bit 12.
	SPI2_CLK	I/O	MFP3	SPI2 serial clock pin.
	I2C0_SMBSUS	O	MFP4	I ² C0 SMBus SMBSUS pin (PMBus CONTROL pin)
	I2C1_SDA	I/O	MFP5	I ² C1 data input/output pin.
	TM1	I/O	MFP13	Timer1 event counter input/toggle output pin.
PG.4	PG.4	I/O	MFP0	General purpose digital I/O pin.
	EBI_ADR13	O	MFP2	EBI address bus bit 13.
	SPI2_MISO	I/O	MFP3	SPI2 MISO (Master In, Slave Out) pin.
	TM2	I/O	MFP13	Timer2 event counter input/toggle output pin.
PG.5	PG.5	I/O	MFP0	General purpose digital I/O pin.
	EBI_nCS1	O	MFP2	EBI chip select 1 output pin.
	SPI3_SS	I/O	MFP3	SPI3 slave select pin.
	SC1_PWR	O	MFP4	Smart Card 1 power pin.
	EPWM0_CH3	I/O	MFP11	EPWM0 channel 3 output/capture input.
PG.6	PG.6	I/O	MFP0	General purpose digital I/O pin.
	EBI_nCS2	O	MFP2	EBI chip select 2 output pin.
	SPI3_CLK	I/O	MFP3	SPI3 serial clock pin.
	SC1_RST	O	MFP4	Smart Card 1 reset pin.
	EPWM0_CH2	I/O	MFP11	EPWM0 channel 2 output/capture input.
PG.7	PG.7	I/O	MFP0	General purpose digital I/O pin.

	Pin Name	Type	MFP	Description
	EBI_nWRL	O	MFP2	EBI low byte write enable output pin.
	SPI3_MISO	I/O	MFP3	SPI3 MISO (Master In, Slave Out) pin.
	SC1_DAT	I/O	MFP4	Smart Card 1 data pin.
	EPWM0_CH1	I/O	MFP11	EPWM0 channel 1 output/capture input.
PG.8	PG.8	I/O	MFP0	General purpose digital I/O pin.
	EBI_nWRH	O	MFP2	EBI high byte write enable output pin
	SPI3_MOSI	I/O	MFP3	SPI3 MOSI (Master Out, Slave In) pin.
	SC1_CLK	O	MFP4	Smart Card 1 clock pin.
	EPWM0_CH0	I/O	MFP11	EPWM0 channel 0 output/capture input.
PG.9	PG.9	I/O	MFP0	General purpose digital I/O pin.
	EBI_AD0	I/O	MFP2	EBI address/data bus bit 0.
	SD1_DAT3	I/O	MFP3	SD/SDIO1 data line bit 3.
	SPIM_D2	I/O	MFP4	SPIM data 2 pin for Quad Mode I/O.
	BPWM0_CH5	I/O	MFP12	BPWM0 channel 5 output/capture input.
PG.10	PG.10	I/O	MFP0	General purpose digital I/O pin.
	EBI_AD1	I/O	MFP2	EBI address/data bus bit 1.
	SD1_DAT2	I/O	MFP3	SD/SDIO1 data line bit 2.
	SPIM_D3	I/O	MFP4	SPIM data 3 pin for Quad Mode I/O.
	BPWM0_CH4	I/O	MFP12	BPWM0 channel 4 output/capture input.
PG.11	PG.11	I/O	MFP0	General purpose digital I/O pin.
	EBI_AD2	I/O	MFP2	EBI address/data bus bit 2.
	SD1_DAT1	I/O	MFP3	SD/SDIO1 data line bit 1.
	SPIM_SS	I/O	MFP4	SPIM slave select pin.
	BPWM0_CH3	I/O	MFP12	BPWM0 channel 3 output/capture input.
PG.12	PG.12	I/O	MFP0	General purpose digital I/O pin.
	EBI_AD3	I/O	MFP2	EBI address/data bus bit 3.
	SD1_DAT0	I/O	MFP3	SD/SDIO1 data line bit 0.
	SPIM_CLK	I/O	MFP4	SPIM serial clock pin.
	BPWM0_CH2	I/O	MFP12	BPWM0 channel 2 output/capture input.
PG.13	PG.13	I/O	MFP0	General purpose digital I/O pin.
	EBI_AD4	I/O	MFP2	EBI address/data bus bit 4.
	SD1_CMD	I/O	MFP3	SD/SDIO1 command/response pin
	SPIM_MISO	I/O	MFP4	SPIM MISO (Master In, Slave Out) pin.
	BPWM0_CH1	I/O	MFP12	BPWM0 channel 1 output/capture input.

	Pin Name	Type	MFP	Description
PG.14	PG.14	I/O	MFP0	General purpose digital I/O pin.
	EBI_AD5	I/O	MFP2	EBI address/data bus bit 5.
	SD1_CLK	O	MFP3	SD/SDIO1 clock output pin
	SPIM_MOSI	I/O	MFP4	SPIM MOSI (Master Out, Slave In) pin.
	BPWM0_CH0	I/O	MFP12	BPWM0 channel 0 output/capture input.
PG.15	PG.15	I/O	MFP0	General purpose digital I/O pin.
	SD1_nCD	I	MFP3	SD/SDIO1 card detect input pin
	CLKO	O	MFP14	Clock Out
	EADC0_ST	I	MFP15	EADC0 external trigger input.
PH.0	PH.0	I/O	MFP0	General purpose digital I/O pin.
	EBI_ADR7	O	MFP2	EBI address bus bit 7.
	UART5_TXD	O	MFP4	UART5 data transmitter output pin.
	TM0_EXT	I/O	MFP13	Timer0 external capture input/toggle output pin.
PH.1	PH.1	I/O	MFP0	General purpose digital I/O pin.
	EBI_ADR6	O	MFP2	EBI address bus bit 6.
	UART5_RXD	I	MFP4	UART5 data receiver input pin.
	TM1_EXT	I/O	MFP13	Timer1 external capture input/toggle output pin.
PH.2	PH.2	I/O	MFP0	General purpose digital I/O pin.
	EBI_ADR5	O	MFP2	EBI address bus bit 5.
	UART5_nRTS	O	MFP4	UART5 request to Send output pin.
	UART4_TXD	O	MFP5	UART4 data transmitter output pin.
	I2C0_SCL	I/O	MFP6	I ² C0 clock pin.
	TM2_EXT	I/O	MFP13	Timer2 external capture input/toggle output pin.
PH.3	PH.3	I/O	MFP0	General purpose digital I/O pin.
	EBI_ADR4	O	MFP2	EBI address bus bit 4.
	SPI1_I2SMCLK	I/O	MFP3	SPI1 I ² S master clock output pin
	UART5_nCTS	I	MFP4	UART5 clear to Send input pin.
	UART4_RXD	I	MFP5	UART4 data receiver input pin.
	I2C0_SDA	I/O	MFP6	I ² C0 data input/output pin.
	TM3_EXT	I/O	MFP13	Timer3 external capture input/toggle output pin.
PH.4	PH.4	I/O	MFP0	General purpose digital I/O pin.
	EBI_ADR3	O	MFP2	EBI address bus bit 3.
	SPI1_MISO	I/O	MFP3	SPI1 MISO (Master In, Slave Out) pin.
PH.5	PH.5	I/O	MFP0	General purpose digital I/O pin.

	Pin Name	Type	MFP	Description
	EBI_ADR2	O	MFP2	EBI address bus bit 2.
	SPI1_MOSI	I/O	MFP3	SPI1 MOSI (Master Out, Slave In) pin.
PH.6	PH.6	I/O	MFP0	General purpose digital I/O pin.
	EBI_ADR1	O	MFP2	EBI address bus bit 1.
	SPI1_CLK	I/O	MFP3	SPI1 serial clock pin.
PH.7	PH.7	I/O	MFP0	General purpose digital I/O pin.
	EBI_ADR0	O	MFP2	EBI address bus bit 0.
	SPI1_SS	I/O	MFP3	SPI1 slave select pin.
PH.8	PH.8	I/O	MFP0	General purpose digital I/O pin.
	EBI_AD12	I/O	MFP2	EBI address/data bus bit 12.
	QSPI0_CLK	I/O	MFP3	Quad SPI0 serial clock pin.
	SC2_PWR	O	MFP4	Smart Card 2 power pin.
	I2S0_DI	I	MFP5	I ² S0 data input pin.
	SPI1_CLK	I/O	MFP6	SPI1 serial clock pin.
	UART3_nRTS	O	MFP7	UART3 request to Send output pin.
	I2C1_SMBAL	O	MFP8	I ² C1 SMBus SMBALTER pin
	I2C2_SCL	I/O	MFP9	I ² C2 clock pin.
	UART1_TXD	O	MFP10	UART1 data transmitter output pin.
PH.9	PH.9	I/O	MFP0	General purpose digital I/O pin.
	EBI_AD13	I/O	MFP2	EBI address/data bus bit 13.
	QSPI0_SS	I/O	MFP3	Quad SPI0 slave select pin.
	SC2_RST	O	MFP4	Smart Card 2 reset pin.
	I2S0_DO	O	MFP5	I ² S0 data output pin.
	SPI1_SS	I/O	MFP6	SPI1 slave select pin.
	UART3_nCTS	I	MFP7	UART3 clear to Send input pin.
	I2C1_SMBSUS	O	MFP8	I ² C1 SMBus SMBSUS pin (PMBus CONTROL pin)
	I2C2_SDA	I/O	MFP9	I ² C2 data input/output pin.
	UART1_RXD	I	MFP10	UART1 data receiver input pin.
PH.10	PH.10	I/O	MFP0	General purpose digital I/O pin.
	EBI_AD14	I/O	MFP2	EBI address/data bus bit 14.
	QSPI0_MISO1	I/O	MFP3	Quad SPI0 MISO1 (Master In, Slave Out) pin.
	SC2_nCD	I	MFP4	Smart Card 2 card detect pin.
	I2S0_LRCK	O	MFP5	I ² S0 left right channel clock output pin.
	SPI1_I2SMCLK	I/O	MFP6	SPI1 I ² S master clock output pin

	Pin Name	Type	MFP	Description
	UART4_TXD	O	MFP7	UART4 data transmitter output pin.
	UART0_TXD	O	MFP8	UART0 data transmitter output pin.
PH.11	PH.11	I/O	MFP0	General purpose digital I/O pin.
	EBI_AD15	I/O	MFP2	EBI address/data bus bit 15.
	QSPI0_MOSI1	I/O	MFP3	Quad SPI0 MOSI1 (Master Out, Slave In) pin.
	UART4_RXD	I	MFP7	UART4 data receiver input pin.
	UART0_RXD	I	MFP8	UART0 data receiver input pin.
	EPWM0_CH5	I/O	MFP11	EPWM0 channel 5 output/capture input.

5 BLOCK DIAGRAM

5.1 NuMicro[®] M480 Block Diagram

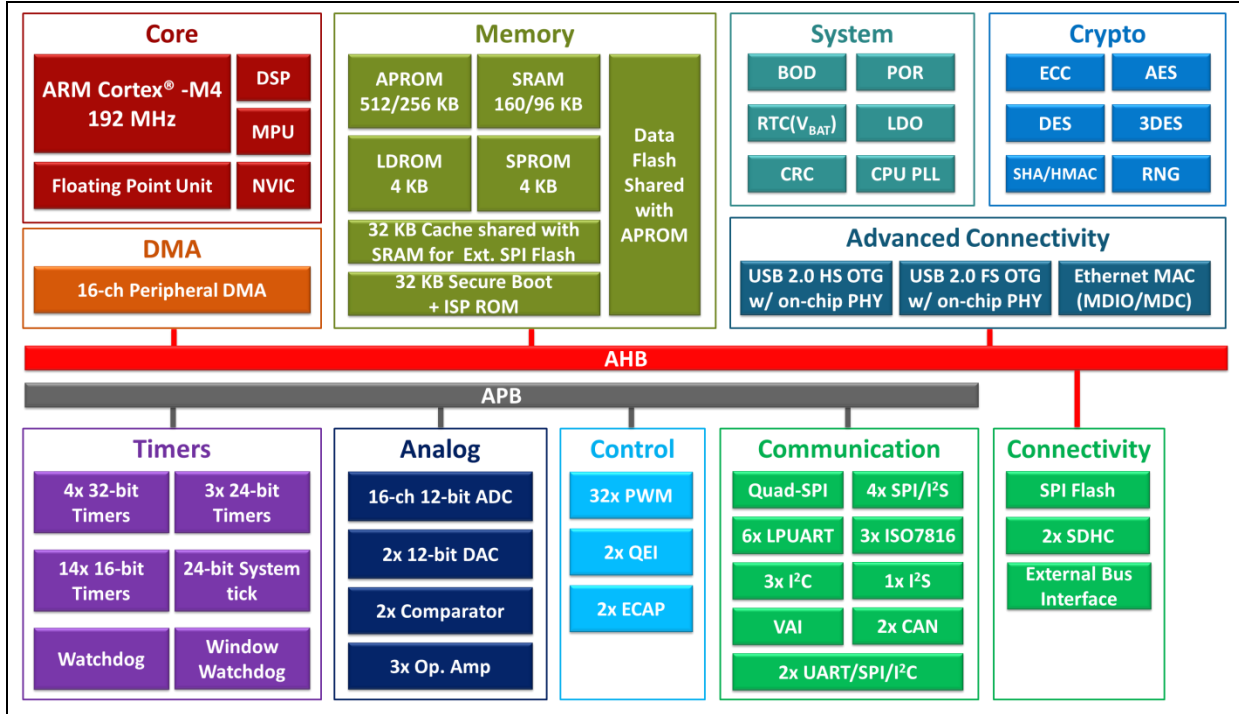

Figure 5.1-1 NuMicro[®] M480 Block Diagram

6 FUNCTIONAL DESCRIPTION

6.1 ARM[®] Cortex[®]-M4 Core

The Cortex[®]-M4 processor, a configurable, multistage, 32-bit RISC processor, has three AMBA AHB-Lite interfaces for best parallel performance and includes an NVIC component. The processor with optional hardware debug functionality can execute Thumb code and is compatible with other Cortex-M profile processors. The profile supports two modes -Thread mode and Handler mode. Handler mode is entered as a result of an exception. An exception return can only be issued in Handler mode. Thread mode is entered on Reset, and can be entered as a result of an exception return. The Cortex[®]-M4F is a processor with the same capability as the Cortex[®]-M4 processor and includes floating point arithmetic functionality. The NuMicro[®] M480 series is embedded with Cortex[®]-M4F processor. Throughout this document, the name Cortex[®]-M4 refers to both Cortex[®]-M4 and Cortex[®]-M4F processors. Figure 6.1-1 shows the functional controller of the processor.

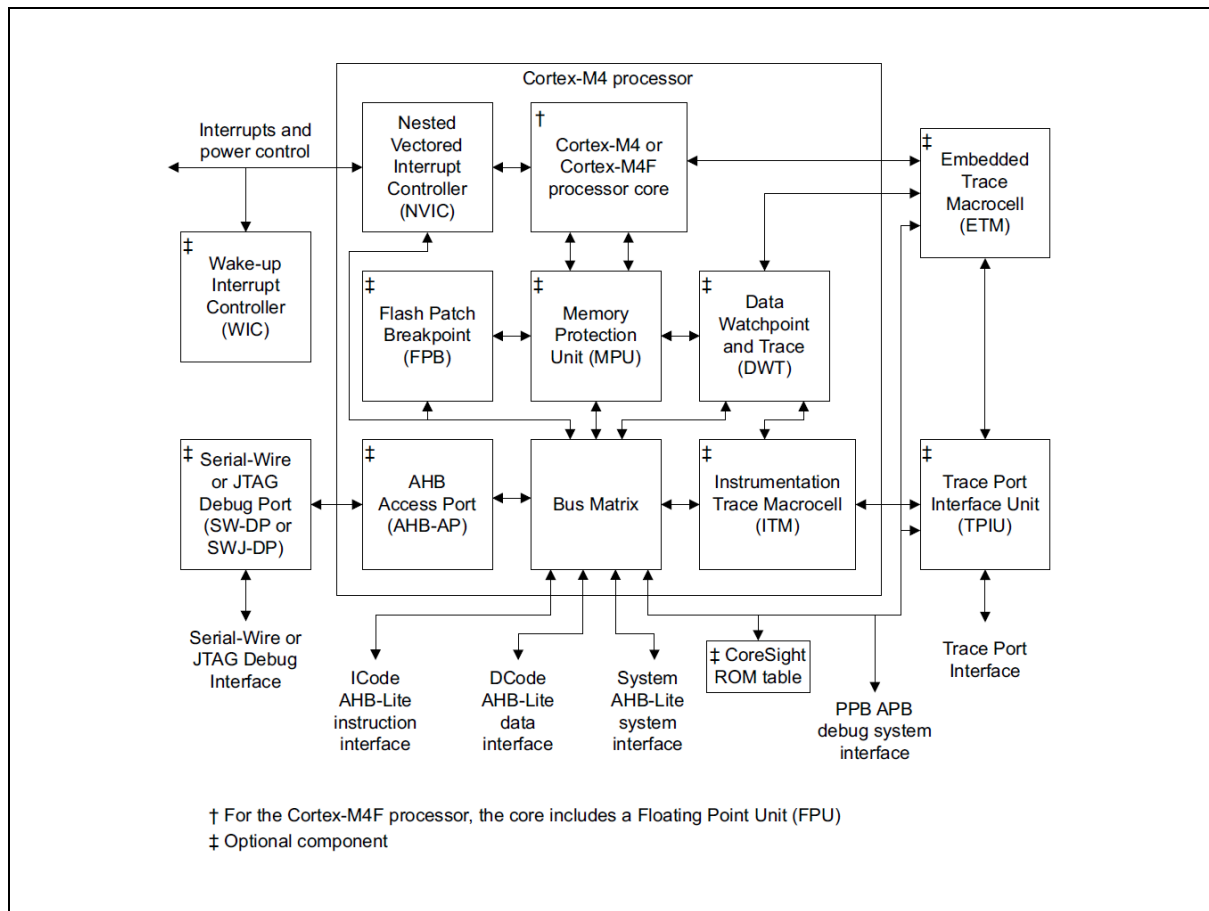

Figure 6.1-1 Cortex[®]-M4 Block Diagram

Cortex[®]-M4 processor features:

- A low gate count processor core, with low latency interrupt processing that has:
 - A subset of the Thumb instruction set, defined in the *ARMv7-M Architecture Reference Manual*
 - Banked Stack Pointer (SP)
 - Hardware integer divide instructions, SDIV and UDIV
 - Handler and Thread modes

- Thumb and Debug states
- Support for interruptible-continued instructions LDM, STM, PUSH, and POP for low interrupt latency
- Automatic processor state saving and restoration for low latency *Interrupt Service Routine (ISR)* entry and exit
- Support for ARMv6 big-endian byte-invariant or little-endian accesses
- Support for ARMv6 unaligned accesses
- Floating Point Unit (FPU) in the Cortex[®]-M4F processor providing:
 - 32-bit instructions for single-precision (C float) data-processing operations
 - Combined Multiply and Accumulate instructions for increased precision (Fused MAC)
 - Hardware support for conversion, addition, subtraction, multiplication with optional accumulate, division, and square-root
 - Hardware support for denormals and all IEEE rounding modes
 - 32 dedicated 32-bit single precision registers, also addressable as 16 double-word registers
 - Decoupled three stage pipeline
- Nested Vectored Interrupt Controller (NVIC) closely integrated with the processor core to achieve low latency interrupt processing. Features include:
 - External interrupts. Configurable from 1 to 240 (the NuMicro[®] M480 series configured with 64 interrupts)
 - Bits of priority, configurable from 3 to 8
 - Dynamic reprioritization of interrupts
 - Priority grouping which enables selection of preempting interrupt levels and nonpreempting interrupt levels
 - Support for trill-chaining and late arrival of interrupts, which enables back-to-back interrupt processing without the overhead of state saving and restoration between interrupts.
 - Processor state automatically saved on interrupt entry, and restored on interrupt exit with on instruction overhead
 - Support for Wake-up Interrupt Controller (WIC) with Ultra-low Power Sleep mode
- Memory Protection Unit (MPU). An optional MPU for memory protection, including:
 - Eight memory regions
 - Sub Region Disable (SRD), enabling efficient use of memory regions
 - The ability to enable a background region that implements the default memory map attributes
- Low-cost debug solution that features:
 - Debug access to all memory and registers in the system, including access to memory mapped devices, access to internal core registers when the core is halted, and access to debug control registers even while SYSRESETn is asserted.
 - Serial Wire Debug Port(SW-DP) or Serial Wire JTAG Debug Port (SWJ-DP) debug access
 - Optional Flash Patch and Breakpoint (FPB) unit for implementing breakpoints and

code patches

- Optional Data Watchpoint and Trace (DWT) unit for implementing watchpoints, data tracing, and system profiling
 - Optional Instrumentation Trace Macrocell (ITM) for support of printf() style debugging
 - Optional Trace Port Interface Unit (TPIU) for bridging to a Trace Port Analyzer (TPA), including Single Wire Output (SWO) mode
 - Optional Embedded Trace Macrocell (ETM) for instruction trace.
- Bus interfaces:
 - Three Advanced High-performance Bus-Lite (AHB-Lite) interfaces: ICode, Dcode, and System bus interfaces
 - Private Peripheral Bus (PPB) based on Advanced Peripheral Bus (APB) interface
 - Bit-band support that includes atomic bit-band write and read operations.
 - Memory access alignment
 - Write buffer for buffering of write data
 - Exclusive access transfers for multiprocessor systems

6.2 System Manager

6.2.1 Overview

System management includes the following sections:

- System Reset
- System Power Distribution
- SRAM Memory Organization
- System Timer (SysTick)
- Nested Vectored Interrupt Controller (NVIC)
- System Control register

6.2.2 System Reset

The system reset can be issued by one of the events listed below. These reset event flags can be read from SYS_RSTSTS register to determine the reset source. Hardware reset sources are from peripheral signals. Software reset can trigger reset through setting control registers.

- Hardware Reset Sources
 - Power-on Reset
 - Low level on the nRESET pin
 - Watchdog Time-out Reset and Window Watchdog Reset (WDT/WWDT Reset)
 - Low Voltage Reset (LVR)
 - Brown-out Detector Reset (BOD Reset)
 - CPU Lockup Reset
- Software Reset Sources
 - CHIP Reset will reset whole chip by writing 1 to CHIPRST (SYS_IPRST0[0])
 - MCU Reset to reboot but keeping the booting setting from APROM or LDROM by writing 1 to SYSRESETREQ (AIRCRCR[2])
 - CPU Reset for Cortex[®]-M4 core only by writing 1 to CPURST (SYS_IPRST0[1])

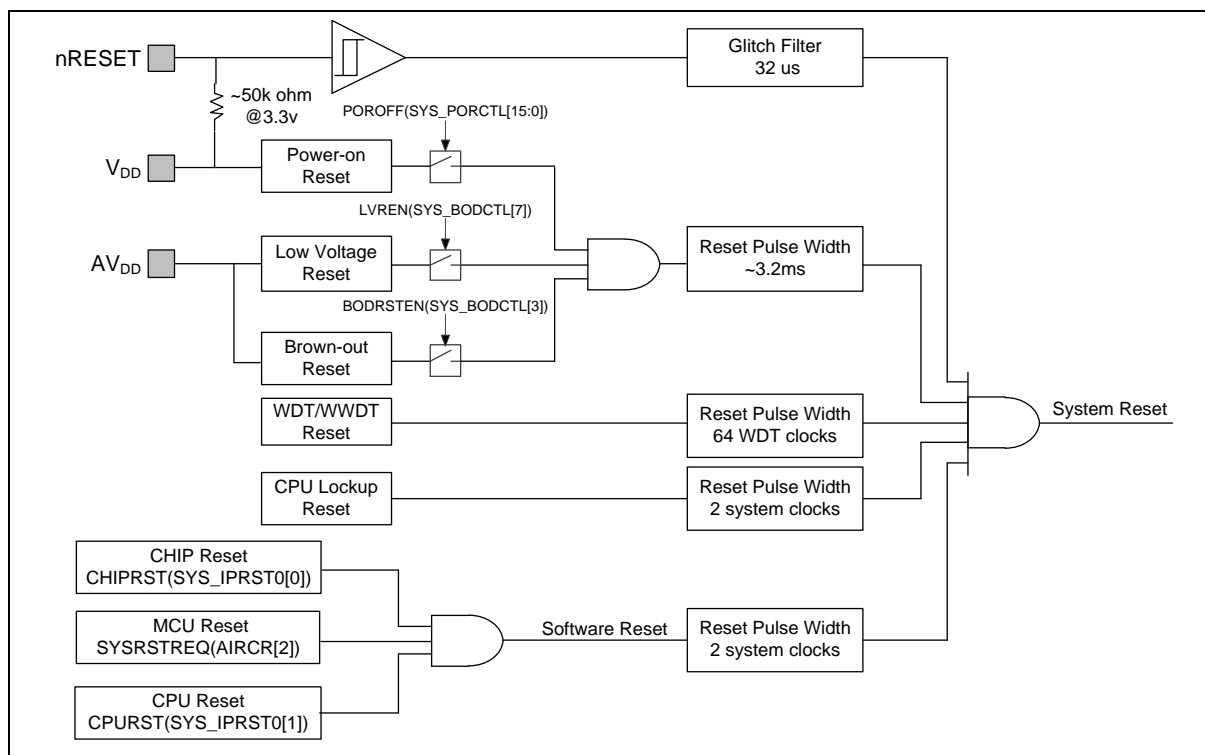

Figure 6.2-1 System Reset Sources

There are a total of 9 reset sources in the NuMicro[®] family. In general, CPU reset is used to reset Cortex[®]-M4 only; the other reset sources will reset Cortex[®]-M4 and all peripherals. However, there are small differences between each reset source and they are listed in Table 6.2-1

Reset Sources Register	POR	NRESET	WDT	LVR	BOD	Lockup	CHIP	MCU	CPU
SYS_RSTSTS	Bit 0 = 1	Bit 1 = 1	Bit 2 = 1	Bit 3 = 1	Bit 4 = 1	Bit 8 = 1	Bit 0 = 1	Bit 5 = 1	Bit 7 = 1
CHIPRST (SYS_IPRST0[0])	0x0	-	-	-	-	-	-	-	-
BODEN (SYS_BODCTL[0])									
BODVL (SYS_BODCTL[2:1])	Reload from CONFIG0	Reload from CONFIG0	Reload from CONFIG0	Reload from CONFIG0	-	Reload from CONFIG0	Reload from CONFIG0	Reload from CONFIG0	-
BODRSTEN (SYS_BODCTL[3])									
HXTEN (CLK_PWRCTL[0])	Reload from CONFIG0	Reload from CONFIG0	Reload from CONFIG0	Reload from CONFIG0	Reload from CONFIG0	Reload from CONFIG0	Reload from CONFIG0	Reload from CONFIG0	
LXTEN (CLK_PWRCTL[1])	0x0	-	-	-	-	-	-	-	-
WDTCKEN (CLK_APBCLK0[0])	0x1	-	0x1	-	-	-	0x1	-	-
HCLKSEL	Reload from	Reload from	Reload from	Reload from	Reload from	Reload from	Reload from	Reload from	-

(CLK_CLKSEL0[2:0])	CONFIG0	CONFIG0	CONFIG0	CONFIG0	CONFIG0	CONFIG0	CONFIG0	CONFIG0	
WDTSEL (CLK_CLKSEL1[1:0])	0x3	0x3	-	-	-	-	-	-	-
HXTSTB (CLK_STATUS[0])	0x0	-	-	-	-	-	-	-	-
LXTSTB (CLK_STATUS[1])	0x0	-	-	-	-	-	-	-	-
PLLSTB (CLK_STATUS[2])	0x0	-	-	-	-	-	-	-	-
HIRCSTB (CLK_STATUS[4])	0x0	-	-	-	-	-	-	-	-
CLKSFAIL (CLK_STATUS[7])	0x0	0x0	-	-	-	-	-	-	-
RSTEN (WDT_CTL[1])	Reload from CONFIG0	Reload from CONFIG0	Reload from CONFIG0	Reload from CONFIG0	Reload from CONFIG0	-	Reload from CONFIG0	-	-
WDTEN (WDT_CTL[7])									
WDT_CTL except bit 1 and bit 7.	0x0700	0x0700	0x0700	0x0700	0x0700	-	0x0700	-	-
WDT_ALTCTL	0x0000	0x0000	0x0000	0x0000	0x0000	-	0x0000	-	-
WWDT_RLDCNT	0x0000	0x0000	0x0000	0x0000	0x0000	-	0x0000	-	-
WWDT_CTL	0x3F0800	0x3F0800	0x3F0800	0x3F0800	0x3F0800	-	0x3F0800	-	-
WWDT_STATUS	0x0000	0x0000	0x0000	0x0000	0x0000	-	0x0000	-	-
WWDT_CNT	0x3F	0x3F	0x3F	0x3F	0x3F	-	0x3F	-	-
BS (FMC_ISPCTL[1])	Reload from CONFIG0	Reload from CONFIG0	Reload from CONFIG0	Reload from CONFIG0	Reload from CONFIG0	-	Reload from CONFIG0	-	-
BL (FMC_ISPCTL[16])									
FMC_DFBA	Reload from CONFIG1	Reload from CONFIG1	Reload from CONFIG1	Reload from CONFIG1	Reload from CONFIG1	-	Reload from CONFIG1	-	-
CBS (FMC_ISPSTS[2:1])	Reload from CONFIG0	Reload from CONFIG0	Reload from CONFIG0	Reload from CONFIG0	Reload from CONFIG0	-	Reload from CONFIG0	-	-
VECMAP (FMC_ISPSTS[23:9])	Reload base on CONFIG0	Reload base on CONFIG0	Reload base on CONFIG0	Reload base on CONFIG0	Reload base on CONFIG0	-	Reload base on CONFIG0	-	-
Other Peripheral Registers	Reset Value								
FMC Registers	Reset Value								

Note: '-' means that the value of register keeps original setting.

Table 6.2-1 Reset Value of Registers

6.2.2.1 nRESET Reset

The nRESET reset means to generate a reset signal by pulling low nRESET pin, which is an asynchronous reset input pin and can be used to reset system at any time. When the nRESET voltage is lower than $0.2 V_{DD}$ and the state keeps longer than 66 us (glitch filter), chip will be reset. The nRESET reset will control the chip in reset state until the nRESET voltage rises above $0.7 V_{DD}$ and the state keeps longer than 66 us (glitch filter). The PINRF(SYS_RSTSTS[1]) will be set to 1 if the previous reset source is nRESET reset. Figure 6.2-2 shows the nRESET reset waveform.

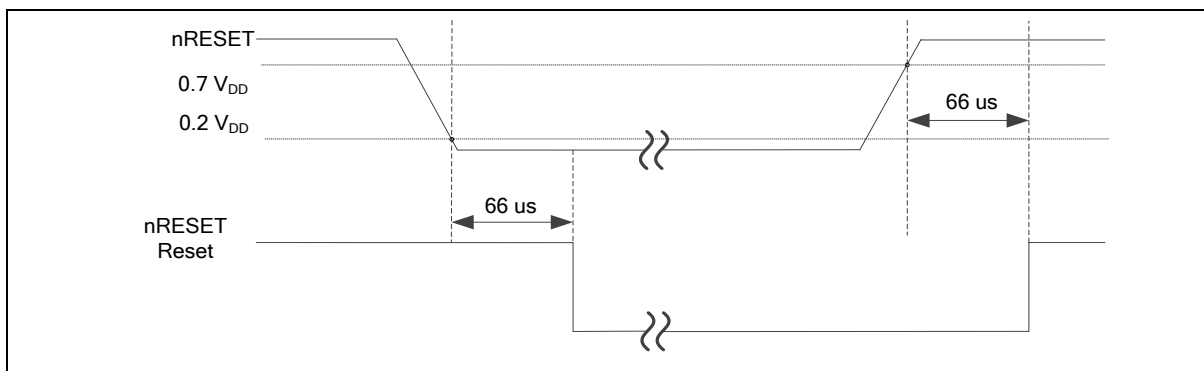

Figure 6.2-2 nRESET Reset Waveform

6.2.2.2 Power-on Reset (POR)

The Power-on reset (POR) is used to generate a stable system reset signal and force the system to be reset when power-on to avoid unexpected behavior of MCU. When applying the power to MCU, the POR module will detect the rising voltage and generate reset signal to system until the voltage is ready for MCU operation. At POR reset, the PORF(SYS_RSTSTS[0]) will be set to 1 to indicate there is a POR reset event. The PORF(SYS_RSTSTS[0]) bit can be cleared by writing 1 to it. Figure 6.2-3 shows the power-on reset waveform.

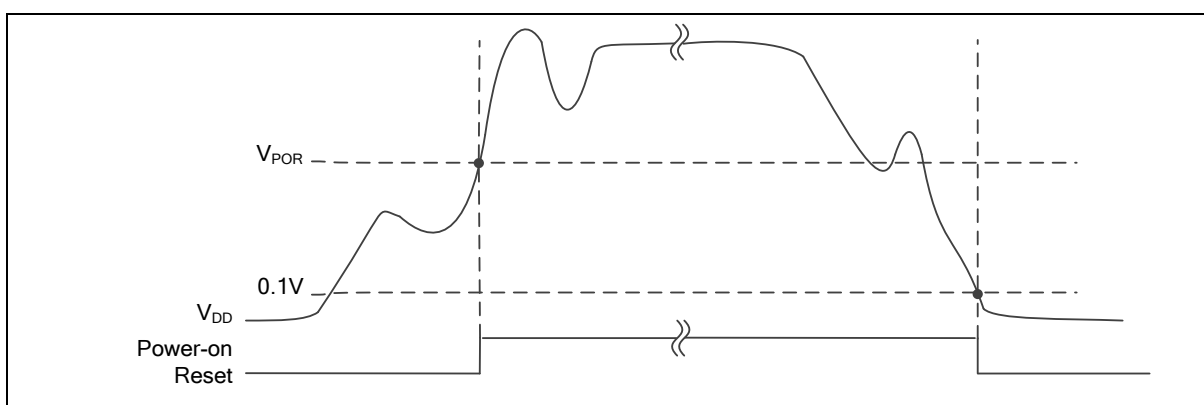

Figure 6.2-3 Power-on Reset (POR) Waveform

6.2.2.3 Low Voltage Reset (LVR)

If the Low Voltage Reset function is enabled by setting the Low Voltage Reset Enable Bit LVREN (SYS_BODCTL[7]) to 1, after 200us delay, LVR detection circuit will be stable and the LVR function will be active. Then LVR function will detect AV_{DD} during system operation. When the AV_{DD} voltage is lower than V_{LVR} and the state keeps longer than De-glitch time set by LVRDGSEL (SYS_BODCTL[14:12]), chip will be reset. The LVR reset will control the chip in reset state until the

AV_{DD} voltage rises above V_{LVR} and the state keeps longer than De-glitch time set by LVRDGSEL (SYS_BODCTL[14:12]). The default setting of Low Voltage Reset is enabled without De-glitch function. Figure 6.2-4 shows the Low Voltage Reset waveform.

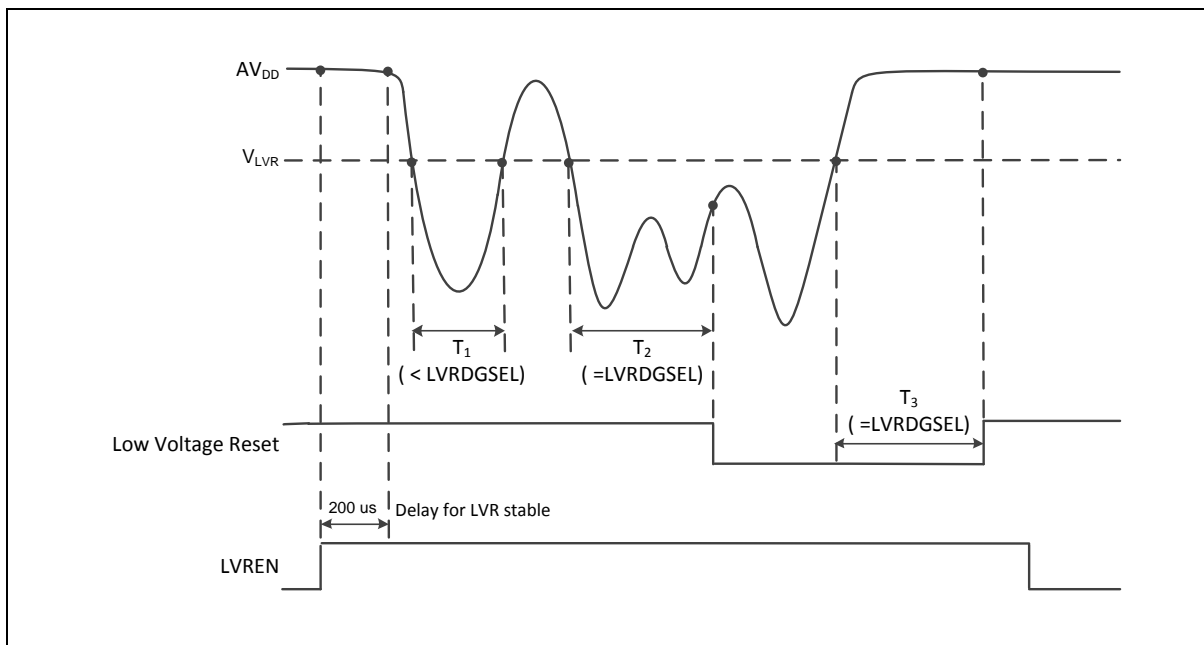

Figure 6.2-4 Low Voltage Reset (LVR) Waveform

6.2.2.4 Brown-out Detector Reset (BOD Reset)

If the Brown-out Detector (BOD) function is enabled by setting the Brown-out Detector Enable Bit BODEN (SYS_BODCTL[0]), Brown-out Detector function will detect AV_{DD} during system operation. When the AV_{DD} voltage is lower than V_{BOD} which is decided by BODEN and BODVL (SYS_BODCTL[18:16]) and the state keeps longer than De-glitch time set by BODDGSEL (SYS_BODCTL[10:8]), chip will be reset. The BOD reset will control the chip in reset state until the AV_{DD} voltage rises above V_{BOD} and the state keeps longer than De-glitch time set by BODDGSEL. The default value of BODEN, BODVL and BODRSTEN (SYS_BODCTL[3]) is set by Flash controller user configuration register CBODEN (CONFIG0 [19]), CBOV (CONFIG0 [23:21]) and CBORST(CONFIG0[20]) respectively. User can determine the initial BOD setting by setting the CONFIG0 register. Figure 6.2-5 shows the Brown-out Detector waveform.

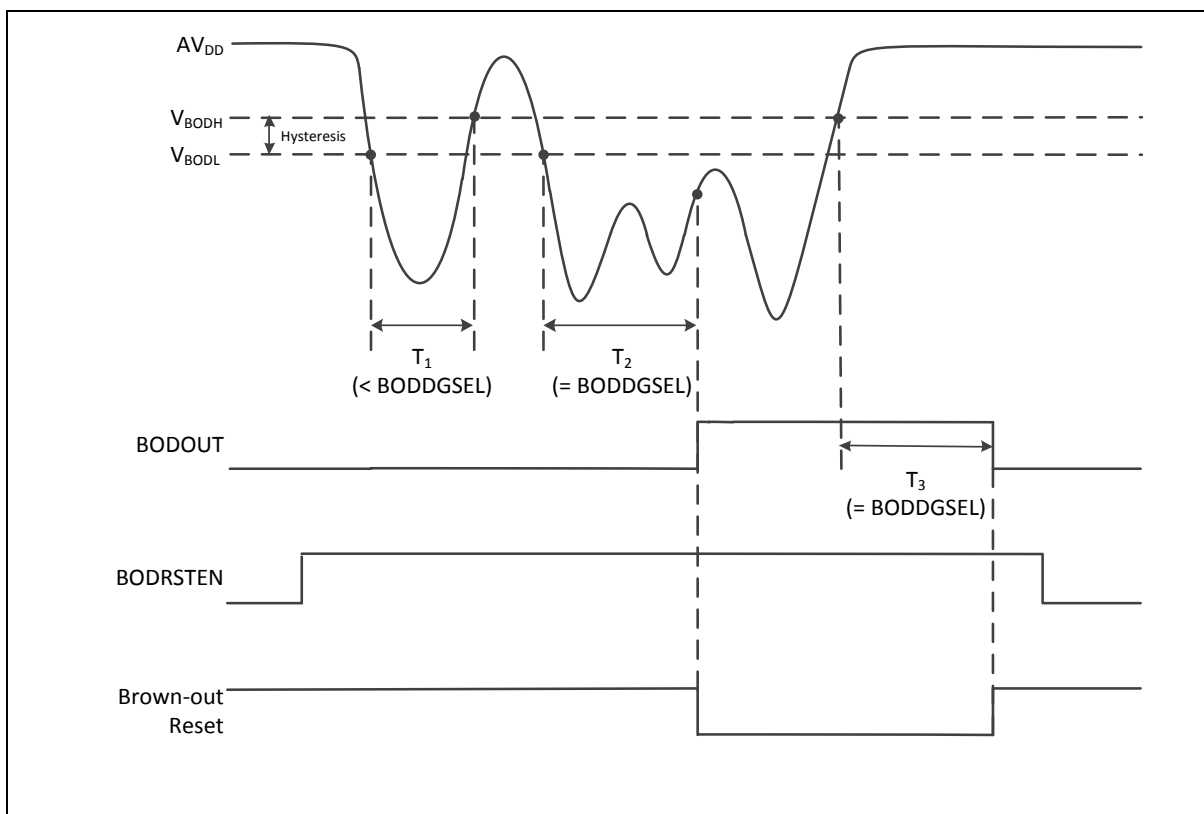

Figure 6.2-5 Brown-out Detector (BOD) Waveform

6.2.2.5 Watchdog Timer Reset (WDT)

In most industrial applications, system reliability is very important. To automatically recover the MCU from failure status is one way to improve system reliability. The watchdog timer(WDT) is widely used to check if the system works fine. If the MCU is crashed or out of control, it may cause the watchdog time-out. User may decide to enable system reset during watchdog time-out to recover the system and take action for the system crash/out-of-control after reset.

Software can check if the reset is caused by watchdog time-out to indicate the previous reset is a watchdog reset and handle the failure of MCU after watchdog time-out reset by checking WDTRF(SYS_RSTSTS[2]).

6.2.2.6 CPU Lockup Reset

CPU enters lockup status after CPU produces hardfault at hardfault handler and chip gives immediate indication of seriously errant kernel software. This is the result of the CPU being locked because of an unrecoverable exception following the activation of the processor's built-in system state protection hardware. When chip enters debug mode, the CPU lockup reset will be ignored.

6.2.2.7 CPU Reset, CHIP Reset and MCU Reset

The CPU Reset means only Cortex[®]-M4 core is reset and all other peripherals remain the same status after CPU reset. User can set the CPURST(SYS_IPRST0[1]) to 1 to assert the CPU Reset signal.

The CHIP Reset is the same with Power-on Reset. The CPU and all peripherals are reset and BS(FMC_ISPCTL[1]) bit is automatically reloaded from CONFIG0 setting. User can set the CHIPRST(SYS_IPRST0[1]) to 1 to assert the CHIP Reset signal.

The MCU Reset is similar with CHIP Reset. The difference is that BS(FMC_ISPCTL[1]) will not be reloaded from CONFIG0 setting and keep its original software setting for booting from APROM or LDROM. User can set the SYSRESETREQ(AIRC[R2]) to 1 to assert the MCU Reset.

6.2.3 System Power Distribution

In this chip, power distribution is divided into four segments:

- Analog power from AV_{DD} and AV_{SS} provides the power for analog components operation.
- Digital power from V_{DD} and V_{SS} supplies the power to the internal regulator which provides a fixed 1.8 V power for digital operation and I/O pins.
- USB transceiver power from V_{BUS} offers the power for operating the USB transceiver.
- RTC power from V_{DD} provides the power for RTC and 80 bytes backup registers.

The outputs of internal voltage regulators, LDO and VDD33, require an external capacitor which should be located close to the corresponding pin. Analog power (AV_{DD}) should be the same voltage level of the digital power (V_{DD}). Figure 6.2-6 shows the NuMicro[®] M480 power distribution.

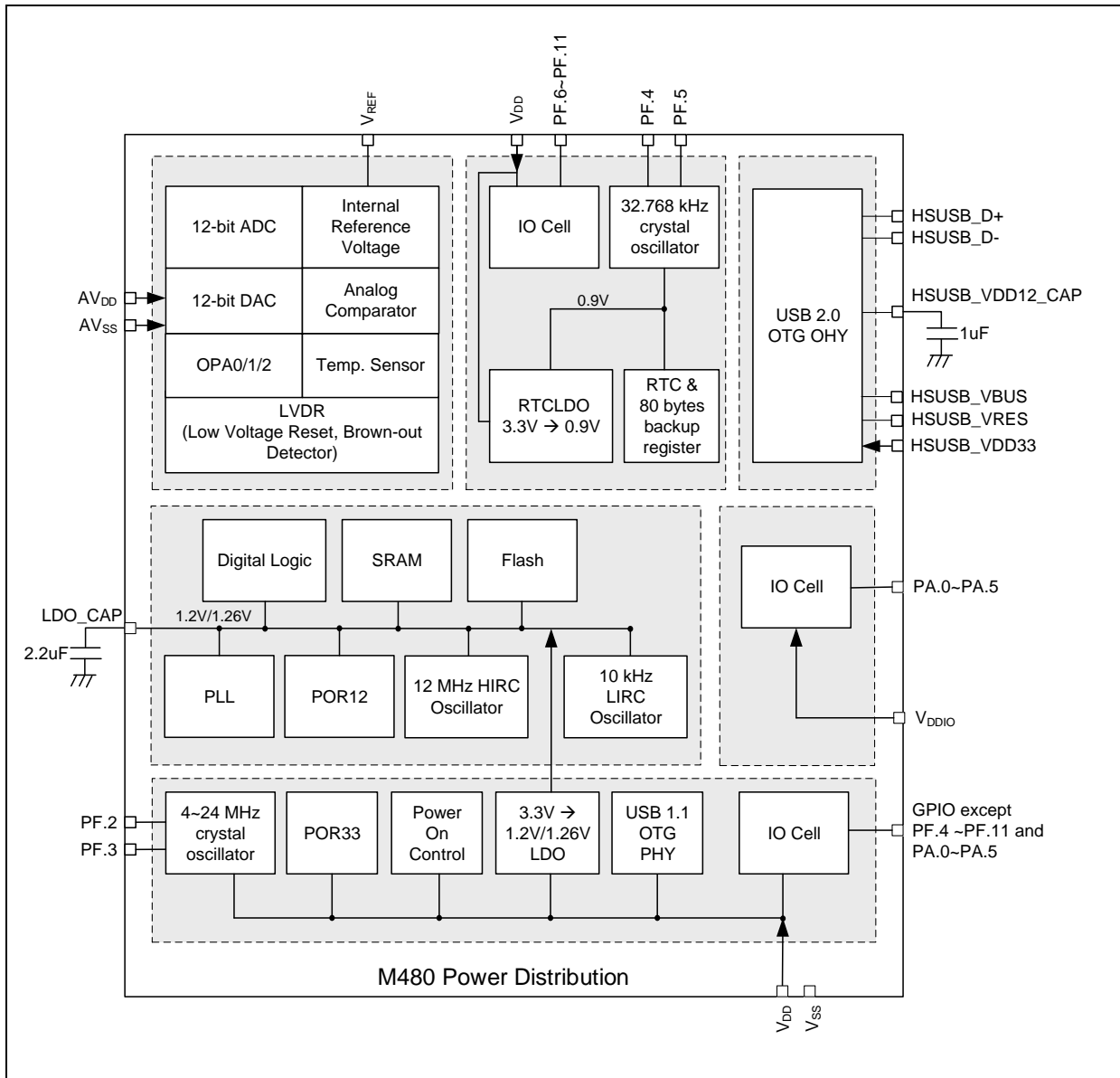

Figure 6.2-6 NuMicro[®] M480 Power Distribution Diagram

6.2.4 Power Modes and Wake-up Sources

The NuMicro[®] M480 series has power manager unit to support several operating modes for saving power. Table 6.2-2 lists all power modes in the NuMicro[®] M480 series.

Mode	CPU Operating Maximum Speed (MHz)	LDO_CAP (V)	Clock Disable
Normal mode	160	1.20	All clocks are disabled by control register.
Turbo mode	192	1.26	All clocks are disabled by control register.
Idle mode	CPU enter Sleep mode	1.20/1.26	Only CPU clock is disabled.
Fast Wakeup Power-down mode (FWPD)	CPU enters Deep Sleep mode	1.20/1.26	Most clocks are disabled except LIRC/LXT, and only RTC/WDT/Timer/UART peripheral clocks still enable if their clock sources are selected as LIRC/LXT.
Normal Power-down mode (NPD)	CPU enters Deep Sleep mode	1.20/1.26	Most clocks are disabled except LIRC/LXT, and only RTC/WDT/Timer/UART peripheral clocks still enable if their clock sources are selected as LIRC/LXT.
Low leakage Power-down mode (LLPD)	CPU enters Deep Sleep mode	0.9	Most clocks are disabled except LIRC/LXT, and only RTC/WDT/Timer/UART peripheral clocks still enable if their clock sources are selected as LIRC/LXT.
Standby Power-down mode 0 (SPD0)	Power off	Floating	Only LIRC/LXT still enable for RTC function and wake-up timer usage
Standby Power-down mode 1 (SPD1)	Power off	Floating	Only LIRC/LXT still enable for RTC function and wake-up timer usage
Deep Power-down mode (DPD)	Power off	Floating	Only LIRC/LXT still enable for RTC function and wake-up timer usage

Table 6.2-2 Power Mode Table

Note:User must turn on LIRC before entering SPD0/1 mode.

There are different power mode entry settings. Each power mode has different entry setting and leaving condition. Table 6.2 3 shows the entry setting for each power mode. When chip power-on, chip is running as normal mode. User can enter each mode by setting SLEEPDEEP (SCR[2]), PDEN (CLK_PWRCTL:[7]) and PDMSEL (CLK_PMUCTL[2:0]) and execute WFI instruction..

Register/Instruction Mode	SLEEPDEEP (SCR[2])	PDEN (CLK_PWRCTL[7])	PDMSEL (CLK_PMUCTL[2:0])
Fast Wakeup Power-down mode	1	1	2
Normal Power-down mode	1	1	0
Low leakage Power-down mode	1	1	1

Standby Power-down mode 0 ^[1]	1	1	4
Standby Power-down mode 1 ^[1]	1	1	5
Deep Power-down mode	1	1	6

Table 6.2-3 Power Mode Difference Table

There are several wake-up sources in Idle mode and Power-down mode. Table 6.2-4 lists the available clocks for each power mode.

Power Mode	Normal Mode	Idle Mode	Power-Down Mode
Definition	CPU is in active state	CPU is in sleep state	CPU is in sleep state and all clocks stop except LXT and LIRC. SRAM content retained.
Entry Condition	Chip is in normal mode after system reset released	CPU executes WFI instruction.	CPU sets sleep mode enable and power down enable and executes WFI instruction.
Wake-up Sources	N/A	All interrupts	RTC, WDT, I ² C, Timer, UART, BOD, GPIO, EINT, USCI, USB, ACMP and BOD.
Available Clocks	All	All except CPU clock	LXT and LIRC
After Wake-up	N/A	CPU back to normal mode	CPU back to normal mode

Table 6.2-4 Power Mode Definition Table

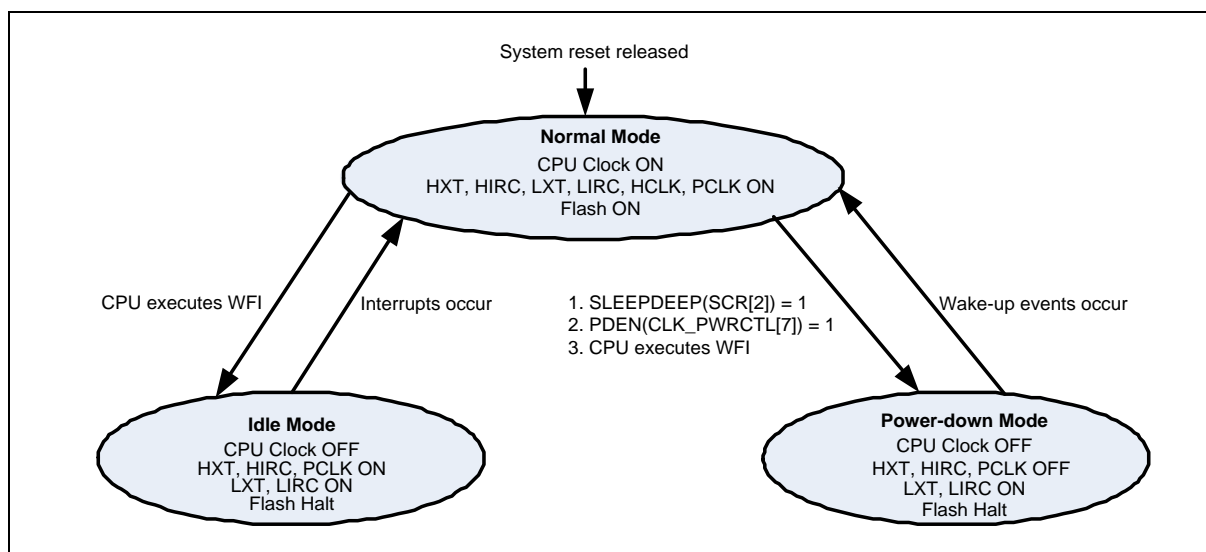

Figure 6.2-7 Power Mode State Machine

	Idle Mode	NPD, LLPD, FWPD	SPD0, SPD1,	DPD
HXT	ON	Halt	Halt	Halt
HIRC	ON	Halt	Halt	Halt
LXT	ON	ON/OFF ^[1]	ON/OFF ^[1]	ON/OFF ^[1]

LIRC	ON	ON/OFF ^[2]	ON/OFF ^[2]	ON/OFF ^[2]
PLL	ON	Halt	Halt	Halt
HCLK/PCLK	ON	Halt	Halt	Halt
CPU	Halt	Halt	Halt	Halt
SRAM Retention	ON	ON	Halt	Halt
FLASH	ON	Halt	Halt	Halt
TIMER	ON	ON/OFF ^[3]	ON/OFF ^[3]	Halt
WDT	ON	ON/OFF ^[4]	ON/OFF ^[4]	Halt
RTC	ON	ON/OFF ^[5]	ON/OFF ^[5]	Halt
UART	ON	ON/OFF ^[6]	ON/OFF ^[6]	Halt
Others	ON	Halt	Halt	Halt

Table 6.2-5 Clocks in Power Modes

Note:

1. LXT ON or OFF depends on SW setting in normal mode.
2. LIRC ON or OFF depends on S/W setting in normal mode.
3. If TIMER clock source is selected as LIRC/LXT and LIRC/LXT is on.
4. If WDT clock source is selected as LIRC and LIRC is on.
5. If RTC clock source is selected as LXT and LXT is on.
6. If UART clock source is selected as LXT and LXT is on.

Wake-up sources in Normal Power-down mode (NPD):

RTC, WDT, I²C, Timer, UART, USCI, BOD, EBOD, GPIO, USB, and ACMP.

After chip enters power down, the following wake-up sources can wake chip up to normal mode. Table 6.2-6 lists the condition about how to enter Power-down mode again for each peripheral.

User needs to wait this condition before setting PDEN(CLK_PWRCTL[7]) and executing WFI to enter Power-down mode.

Wake-Up Source	Wake-Up Condition	Power-Down Mode			Re-Entering Power-Down Mode Condition
		NPD/ FWPD/ LLPD	SPD0/1	DPD	
BOD	Brown-Out Detector Reset / Interrupt	V	-	-	After software writes 1 to clear BODIF (SYS_BODCTL[4]).
	Brown-Out Detector Reset	-	V	-	After software writes 1 to clear BODWK (CLK_PMUSTS[13]) when SPD mode is entered.
LVR	LVR Reset	V	-	-	After software writes 1 to clear LVRF (SYS_RSTSTS[3]).
		-	V	-	After software writes 1 to clear LVRWK (CLK_PMUSTS[12]) when SPD mode is entered.
POR	POR Reset	V	V	-	After software writes 1 to clear PORF (SYS_RSTSTS[0]).

INT	External Interrupt	V	-	-	After software write 1 to clear the Px_INTSRC[n] bit.
GPIO	GPIO Interrupt	V	-	-	After software write 1 to clear the Px_INTSRC[n] bit.
GPIO(PA~PD) Wake-up pin	rising or falling edge event, 64-pin	-	V	-	After software writes 1 to clear GPxWK (CLK_PMUSTS[11:8]) when SPD mode is entered.
GPIO(PC.0) Wake-up pin	rising or falling edge event, 1-pin	-	-	V	After software writes 1 to clear PINWK (CLK_PMUSTS[1]) when DPD mode is entered.
TIMER	Timer Interrupt	V	-	-	After software writes 1 to clear TWKF (TIMERx_INTSTS[1]) and TIF (TIMERx_INTSTS[0]).
Wakeup timer	Wakeup by wake-up timer time-out	-	V	V	After software writes 1 to clear TMRWK (CLK_PMUSTS[1]) when SPD or DPD mode is entered.
WDT	WDT Interrupt	V	-	-	After software writes 1 to clear WKF (WDT_CTL[5]) (Write Protect).
RTC	Alarm Interrupt	V	-	-	After software writes 1 to clear ALMIF (RTC_INTSTS[0]).
	Time Tick Interrupt	V	-	-	After software writes 1 to clear TICKIF (RTC_INTSTS[1]).
	Wakeup by RTC alarm	-	V	V	After software writes 1 to clear RTCWK (CLK_PMUSTS[2]) when DPD or SPD mode is entered.
	Wakeup by RTC tick time	-	V	V	After software writes 1 to clear RTCWK (CLK_PMUSTS[2]) when DPD or SPD mode is entered.
UART	nCTS wake-up	V	-	-	After software writes 1 to clear CTSWKF (UARTx_WKSTS[0]).
	RX Data wake-up	V	-	-	After software writes 1 to clear DATWKF (UARTx_WKSTS[1]).
	Received FIFO Threshold Wake-up	V	-	-	After software writes 1 to clear RFRTWKF (UARTx_WKSTS[2]).
	RS-485 AAD Mode Wake-up	V	-	-	After software writes 1 to clear RS485WKF (UARTx_WKSTS[3]).
	Received FIFO Threshold Time-out Wake-up	V	-	-	After software writes 1 to clear TOUTWKF (UARTx_WKSTS[4]).
USCI UART	CTS Toggle	V	-	-	After software writes 1 to clear WKF (UART_WKSTS[0]).
	Data Toggle	V	-	-	After software writes 1 to clear WKF (UART_WKSTS[0]).
USCI I ² C	Data toggle	V	-	-	After software writes 1 to clear WKF (UI2C_WKSTS[0]).
	Address match	V	-	-	After software writes 1 to clear WKAKDONE (UI2C_PROTSTS[16], then writes 1 to clear WKF (UI2C_WKSTS[0]).
USCI SPI	SS Toggle	V	-	-	After software writes 1 to clear WKF (USPI_WKSTS[0]).

I ² C	Address match wake-up	V	-	-	After software writes 1 to clear WKAKDONE (I2C_WKSTS[1]). Then software writes 1 to clear WKIF (I2C_WKSTS[0]).
USBD	Remote Wake-up	V	-	-	After software writes 1 to clear BUSIF (USBD_INTSTS[0]).
ACMP	Comparator Power-Down Wake-Up Interrupt	V	-	-	After software writes 1 to clear WKIF0 (ACMP_STATUS[8]) and WKIF1 (ACMP_STATUS[9]).
ACMP	ACMPO status change	-	V	-	After software writes 1 to clear ACMPOWK (CLK_PMUSTS[14]) when SPD mode is entered.

Table 6.2-6 Re-Entering Power-down Mode Condition

6.2.5 Power Modes Transition

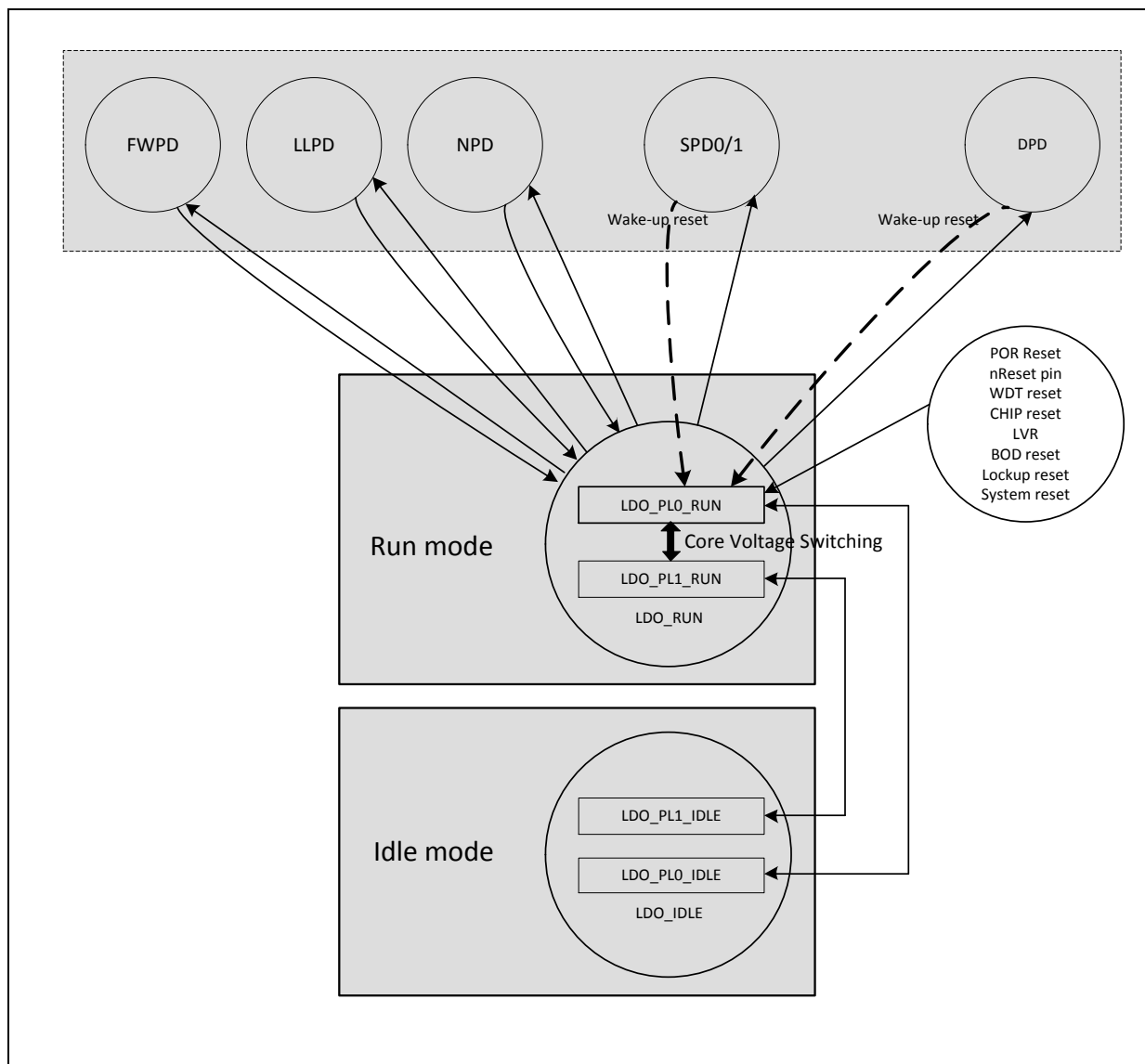

Figure 6.2-8 NuMicro[®] M480 Power Distribution Diagram

6.2.6 System Memory Map

The NuMicro[®] M480 series provides 4G-byte addressing space. The memory locations assigned to each on-chip controllers are shown in Table 6.2-7. The detailed register definition, memory space, and programming will be described in the following sections for each on-chip peripheral. The NuMicro[®] M480 series only supports little-endian data format.

Address Space	Token	Controllers
Flash and SRAM Memory Space		
0x0000_0000 – 0x0003_FFFF	FLASH_BA	FLASH Memory Space (256KB)
0x0000_0000 – 0x0007_FFFF	FLASH_BA	FLASH Memory Space (512KB)
0x0800_0000 – 0x09FF_FFFF	SPIM_BA	SPIM Memory Space (32MB)
0x2000_0000 – 0x2000_7FFF	SRAM0_BA	SRAM Memory Space (32KB)
0x2000_8000 – 0x2001_FFFF	SRAM1_BA	SRAM Memory Space (96KB)
0x2002_0000 – 0x2002_7FFF	SRAM2_BA	SRAM Memory Space (32KB) for CPU only and share with SPIM cache
0x6000_0000 – 0x6FFF_FFFF	EXTMEM_BA	External Memory Space (256MB)
Peripheral Controllers Space (0x4000_0000 – 0x400F_FFFF)		
0x4000_0000 – 0x4000_01FF	SYS_BA	System Control Registers
0x4000_0200 – 0x4000_02FF	CLK_BA	Clock Control Registers
0x4000_0300 – 0x4000_03FF	NMI_BA	NMI Control Registers
0x4000_4000 – 0x4000_4FFF	GPIO_BA	GPIO Control Registers
0x4000_7000 – 0x4000_7FFF	SPIM_BA	SPIM Control Registers
0x4000_8000 – 0x4000_8FFF	PDMA_BA	Peripheral DMA Control Registers
0x4000_9000 – 0x4000_9FFF	USBH_BA	USB Host Control Registers
0x4000_B000 – 0x4000_BFFF	EMAC_BA	Ethernet MAC Control Registers
0x4000_C000 – 0x4000_CFFF	FMC_BA	Flash Memory Control Registers
0x4000_D000 – 0x4000_DFFF	SDH0_BA	SDHOST0 Control Registers
0x4000_E000 – 0x4000_EFFF	SDH1_BA	SDHOST1 Control Registers
0x4001_0000 – 0x4001_0FFF	EBI_BA	External Bus Interface Control Registers
0x4001_9000 – 0x4001_9FFF	HSUSBD_BA	HSUSBD Control Registers
0x4001_A000 – 0x4001_AFFF	HSUSBH_BA	HSUSBH Host Control Registers
0x4003_1000 – 0x4003_1FFF	CRC_BA	CRC Generator Registers
0x4003_E000 – 0x4003_EFFF	SWDC_BA	SWD Control Registers
0x4003_F000 – 0x4003_FFFF	ETMC_BA	ETM Control Registers
0x5008_0000 – 0x5008_0FFF	CRYP_BA	Cryptographic Accelerator Registers
APB Controllers Space (0x4000_0000 ~ 0x400F_FFFF)		
0x4004_0000 – 0x4004_0FFF	WDT_BA	Watchdog Timer Control Registers
0x4004_1000 – 0x4004_1FFF	RTC_BA	Real Time Clock (RTC) Control Register

0x4004_3000 – 0x4004_3FFF	EADC_BA	Enhanced Analog-Digital-Converter (EADC) Control Registers
0x4004_5000 – 0x4004_5FFF	ACMP01_BA	Analog Comparator 0/ 1 Control Registers
0x4004_6000 – 0x4004_6FFF	OPA_BA	OP Amplifier Control Registers
0x4004_7000 – 0x4004_7FFF	DAC_BA	DAC Control Registers
0x4004_8000 – 0x4004_8FFF	I2S0_BA	I ² S0 Interface Control Registers
0x4004_D000 – 0x4004_DFFF	OTG_BA	OTG Control Registers
0x4004_F000 – 0x4004_FFFF	HSOTG_BA	HSOTG Control Registers
0x4005_0000 – 0x4005_0FFF	TMR01_BA	Timer0/Timer1 Control Registers
0x4005_1000 – 0x4005_1FFF	TMR23_BA	Timer2/Timer3 Control Registers
0x4005_8000 – 0x4005_8FFF	EPWM0_BA	PWM0 Control Registers
0x4005_9000 – 0x4005_9FFF	EPWM1_BA	PWM1 Control Registers
0x4005_A000 – 0x4005_AFFF	BPWM0_BA	BPWM0 Control Registers
0x4005_B000 – 0x4005_BFFF	BPWM1_BA	BPWM1 Control Registers
0x4006_0000 – 0x4006_0FFF	QSPI0_BA	Quad SPI0 Control Registers
0x4006_1000 – 0x4006_1FFF	SPI0_BA	SPI0 Control Registers
0x4006_2000 – 0x4006_2FFF	SPI1_BA	SPI1 Control Registers
0x4006_3000 – 0x4006_3FFF	SPI2_BA	SPI2 Control Registers
0x4006_4000 – 0x4006_4FFF	SPI3_BA	SPI3 Control Registers
0x4007_0000 – 0x4007_0FFF	UART0_BA	UART0 Control Registers
0x4007_1000 – 0x4007_1FFF	UART1_BA	UART1 Control Registers
0x4007_2000 – 0x4007_2FFF	UART2_BA	UART2 Control Registers
0x4007_3000 – 0x4007_3FFF	UART3_BA	UART3 Control Registers
0x4007_4000 – 0x4007_4FFF	UART4_BA	UART4 Control Registers
0x4007_5000 – 0x4007_5FFF	UART5_BA	UART5 Control Registers
0x4008_0000 – 0x4008_0FFF	I2C0_BA	I ² C0 Control Registers
0x4008_1000 – 0x4008_1FFF	I2C1_BA	I ² C1 Control Registers
0x4008_2000 – 0x4008_2FFF	I2C2_BA	I ² C2 Control Registers
0x4009_0000 – 0x4009_0FFF	SC0_BA	Smartcard Host 0 Control Registers
0x4009_1000 – 0x4009_1FFF	SC1_BA	Smartcard Host 1 Control Registers
0x4009_2000 – 0x4009_2FFF	SC2_BA	Smartcard Host 2 Control Registers
0x4009_3000 – 0x4009_3FFF	SC3_BA	Smartcard Host 3 Control Registers
0x400A_0000 – 0x400A_0FFF	CAN0_BA	CAN0 Bus Control Registers
0x400A_1000 – 0x400A_1FFF	CAN1_BA	CAN1 Bus Control Registers
0x400B_0000 – 0x400B_0FFF	QEI0_BA	QEI0 Control Registers
0x400B_1000 – 0x400B_1FFF	QEI1_BA	QEI1 Control Registers

0x400B_4000 – 0x400B_4FFF	ECAP0_BA	ECAP0 Control Registers
0x400B_5000 – 0x400B_5FFF	ECAP1_BA	ECAP1 Control Registers
0x400C_0000 – 0x400C_0FFF	USBD_BA	USB Device Control Register
0x400D_0000 – 0x400D_0FFF	USCI0_BA	USCI0 Control Registers
0x400D_1000 – 0x400D_1FFF	USCI1_BA	USCI1 Control Registers
System Controllers Space (0xE000_E000 ~ 0xE000_EFFF)		
0xE000_E010 – 0xE000_E0FF	SCS_BA	System Timer Control Registers
0xE000_E100 – 0xE000_ECFF	SCS_BA	External Interrupt Controller Control Registers
0xE000_ED00 – 0xE000_ED8F	SCS_BA	System Control Registers

Table 6.2-7 Address Space Assignments for On-Chip Controllers

6.2.7 SRAM Memory Organization

The M480 series supports embedded SRAM with total 160 Kbytes and the SRAM organization is separated to two banks: SRAM bank0 and SRAM bank1 and SRAM bank2. The first bank has 32 Kbytes address space, the second bank has 96 Kbyte address space and the third bank has 32Kbyte. These three banks address space can be accessed simultaneously. The SRAM bank0 supports parity error check to make sure chip operating more stable. The SRAM bank2 is shared with SPIM cache, it can switch to external SPI Flash cache memory.

- Supports total 160 Kbytes SRAM
- Supports byte / half word / word write
- Supports fixed 32 Kbytes SRAM bank0 for independent access
- Supports parity error check function for SRAM bank0
- Supports oversize response error
- Supports remap address to 0x1000_0000

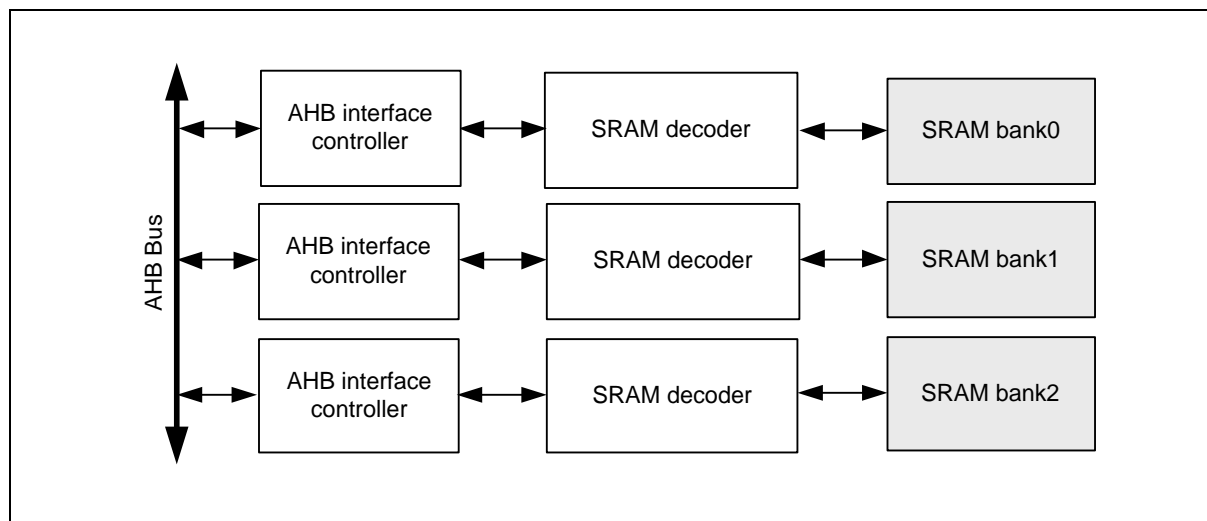

Figure 6.2-9 SRAM Block Diagram

Figure 6.2-9 shows the SRAM organization of M480. There are three SRAM banks in M480. The

bank0 is addressed to 32 Kbytes, the bank1 is addressed to 96 Kbytes and the bank2 is addressed to 32 Kbyte. The bank0 address space is from 0x2000_0000 to 0x2000_7FFF. The bank1 address space is from 0x2000_8000 to 0x2001_FFFF. The bank2 address space is from 0x2002_0000 to 0x2002_7FFF. The address between 0x2002_8000 to 0x3FFF_FFFF is illegal memory space and chip will enter hardfault if CPU accesses these illegal memory addresses.

The address of each bank is remapping from 0x2000_0000 to 0x1000_0000. CPU can access SRAM bank0 through 0x2000_0000 to 0x2000_7FFF or 0x1000_0000 to 0x1000_7FFF, and access SRAM bank1 through 0x2000_8000 to 0x2001_FFFF or 0x1000_8000 to 0x1001_FFFF, and access SRAM bank2 through 0x2002_0000 to 0x2002_7FFF or 0x1002_0000 to 0x1002_7FFF.

When setting the control register CCMEN(SPIM_CTL1[2]) to 0, SRAM bank2 is switched to external SPI Flash cache memory. In this case, the SRAM bank2 can't be accessed as gernal SRAM. If user access SRAM bank2 by AHB bus master, the SPI Flash controller will send error response via HRESP AHB bus signal to bus master.

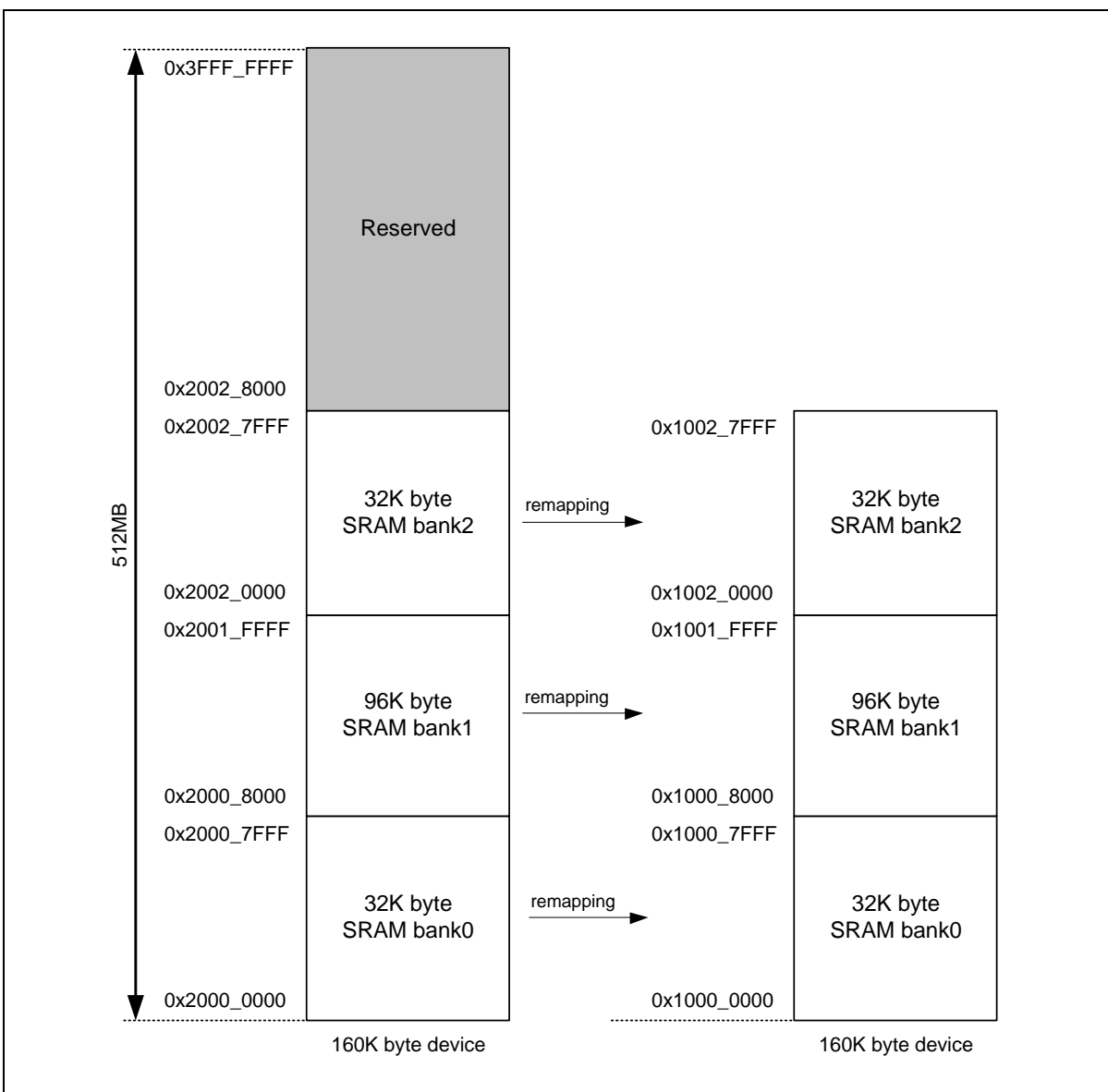

Figure 6.2-10 SRAM Memory Organization

SRAM bank0 has byte parity error check function. When CPU is accessing SRAM bank0, the parity

error checking mechanism is dynamic operating. As parity error occurred, the PERRIF (SYS_SRAM_STATUS[0]) will be asserted to 1 and the SYS_SRAM_ERRADDR register will recode the address with parity error. Chip will enter interrupt when SRAM parity error occurred if PERRIEN (SYS_SRAM_INTCTL[0]) is set to 1. When SRAM parity error occurred, chip will stop detecting SRAM parity error until user writes 1 to clear the PERRIF(SYS_SRAM_STATUS[0]) bit.

6.2.8 Bus Matrix

The M480 series supports Bus Matrix to manage the access arbitration between masters. The access arbitration can be selected by INTACTEN (SYS_AHBMCTL[0]) to use round-robin algorithm or set Cortex[®]-M4 CPU as the highest bus priority.

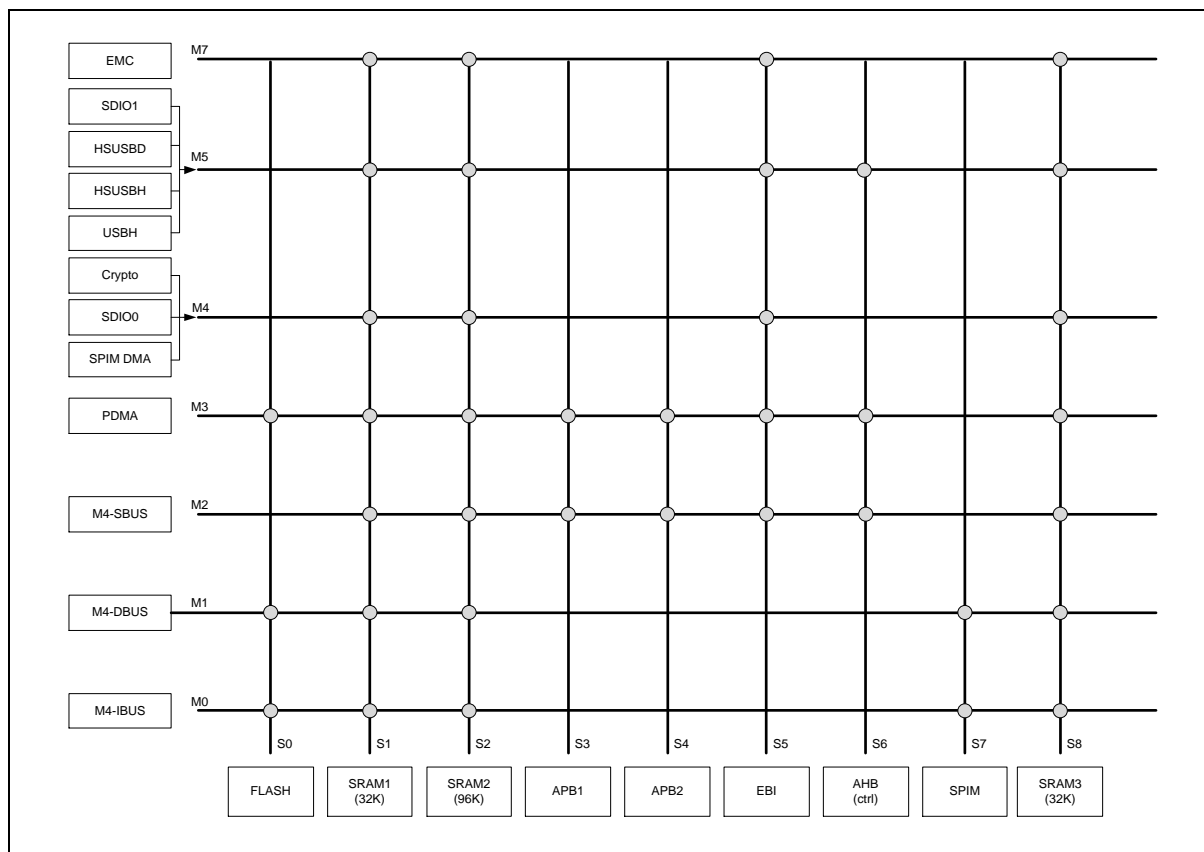

Figure 6.2-11 NuMicro[®] M480 Bus Matrix Diagram

6.2.9 HIRC Auto Trim

This chip supports auto-trim function: the HIRC trim (12 MHz RC oscillator), according to the accurate LXT (32.768 kHz crystal oscillator) or USB SOF (Start-Of-Frame), automatically gets accurate HIRC output frequency, 0.25 % deviation within all temperature ranges.

For instance, the system needs an accurate 12 MHz clock. In such case, if neither using use PLL as the system clock source nor soldering 32.768 kHz crystal in system, user has to set REFCKSEL (SYS_IRCTCTL[10] reference clock selection) to “1”, set FREQSEL (SYS_IRCTCTL[1:0] trim frequency selection) to “10”, and the auto-trim function will be enabled. Interrupt status bit FREQLOCK (SYS_IRCTISTS[8] HIRC frequency lock status) “1” indicates the HIRC output frequency is accurate within 0.25% deviation.

6.2.10 System Timer (SysTick)

The Cortex[®]-M4 includes an integrated system timer, SysTick, which provides a simple, 24-bit clear-on-write, decrementing, wrap-on-zero counter with a flexible control mechanism. The counter can be used as a Real Time Operating System (RTOS) tick timer or as a simple counter.

When system timer is enabled, it will count down from the value in the SysTick Current Value Register (SYST_VAL) to 0, and reload (wrap) to the value in the SysTick Reload Value Register (SYST_LOAD) on the next clock cycle, and then decrement on subsequent clocks. When the counter transitions to 0, the COUNTFLAG status bit is set. The COUNTFLAG bit clears on reads.

The SYST_VAL value is UNKNOWN on reset. Software should write to the register to clear it to 0 before enabling the feature. This ensures the timer will count from the SYST_LOAD value rather than an arbitrary value when it is enabled.

If the SYST_LOAD is 0, the timer will be maintained with a current value of 0 after it is reloaded with this value. This mechanism can be used to disable the feature independently from the timer enable bit.

For more detailed information, please refer to the “ARM[®] Cortex[®]-M4 Technical Reference Manual” and “ARM[®] v6-M Architecture Reference Manual”.

6.2.11 Nested Vectored Interrupt Controller (NVIC)

The NVIC and the processor core interface are closely coupled to enable low latency interrupt processing and efficient processing of late arriving interrupts. The NVIC maintains knowledge of the stacked, or nested, interrupts to enable tail-chaining of interrupts. You can only fully access the NVIC from privileged mode, but you can cause interrupts to enter a pending state in user mode if you enable the Configuration and Control Register. Any other user mode access causes a bus fault. You can access all NVIC registers using byte, halfword, and word accesses unless otherwise stated. NVIC registers are located within the SCS (System Control Space). All NVIC registers and system debug registers are little-endian regardless of the endianness state of the processor.

The NVIC supports:

- An implementation-defined number of interrupts, in the range 1-240 interrupts.
- A programmable priority level of 0-16 for each interrupt; a higher level corresponds to a lower priority, so level 0 is the highest interrupt priority.
- Level and pulse detection of interrupt signals.
- Dynamic reprioritization of interrupts.
- Grouping of priority values into group priority and subpriority fields.
- Interrupt tail-chaining.
- An external Non Maskable Interrupt (NMI)
- WIC with Ultra-low Power Sleep mode support

The processor automatically stacks its state on exception entry and unstacks this state on exception exit, with no instruction overhead. This provides low latency exception handling.

6.3 Clock Controller

6.3.1 Overview

The clock controller generates clocks for the whole chip, including system clocks and all peripheral clocks. The clock controller also implements the power control function with the individually clock ON/OFF control, clock source selection and a clock divider. The chip will not enter Power-down mode until CPU sets the Power-down enable bit PDEN(CLK_PWRCTL[7]) and Cortex[®]-M4 core executes the WFI instruction. After that, chip enters Power-down mode and wait for wake-up interrupt source triggered to leave Power-down mode. In Power-down mode, the clock controller turns off the 4~24 MHz external high speed crystal (HXT) and 12 MHz internal high speed RC oscillator (HIRC) to reduce the overall system power consumption. Figure 6.3-1 shows the clock generator and the overview of the clock source control.

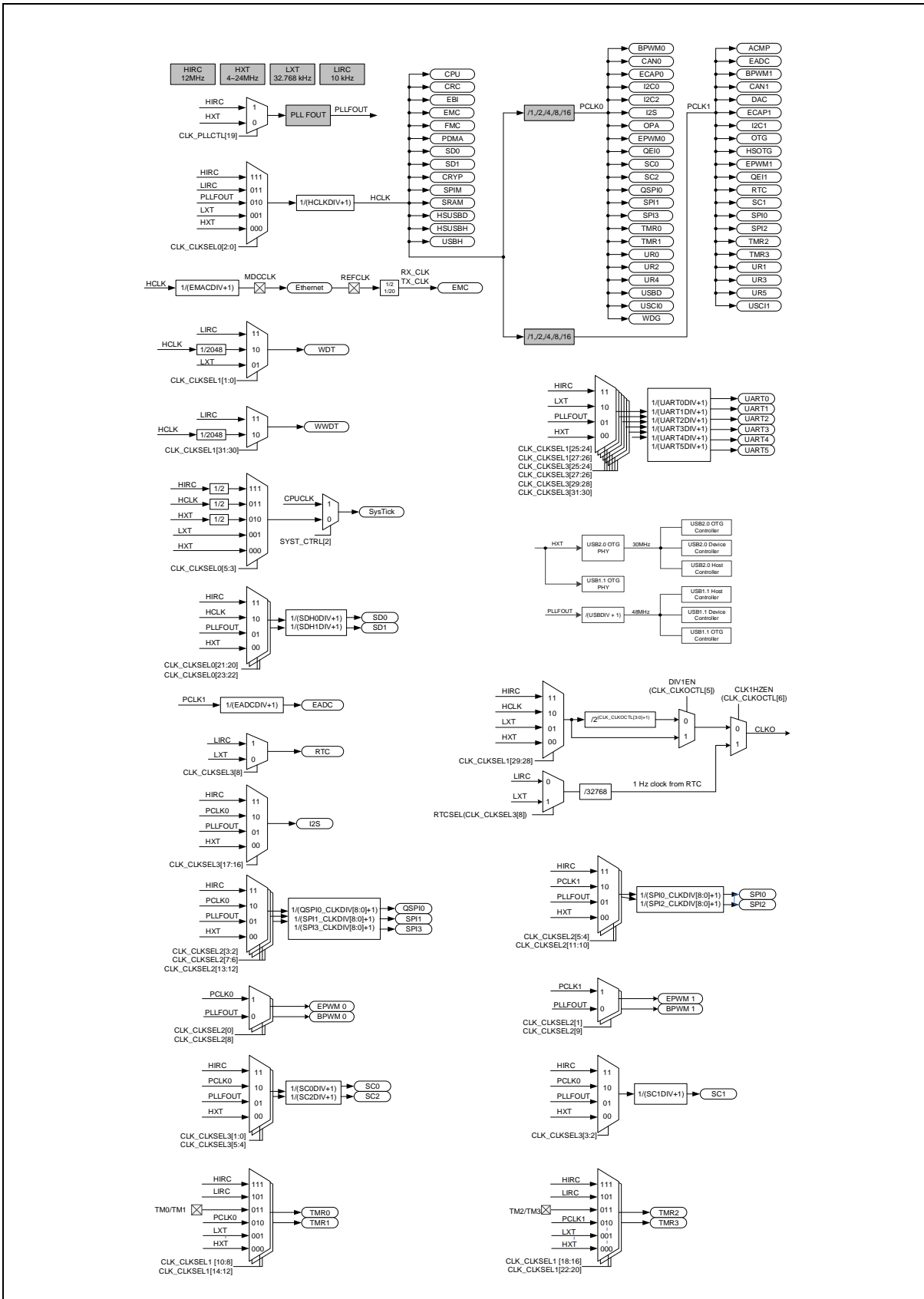

Figure 6.3-1 Clock Generator Global View Diagram

6.3.2 Clock Generator

The clock generator consists of 5 clock sources, which are listed below:

- 32.768 kHz external low speed crystal oscillator (LXT)
- 4~24 MHz external high speed crystal oscillator (HXT)
- Programmable PLL output clock frequency (PLLFOUT), PLL source can be selected from external 4~24 MHz external high speed crystal (HXT) or 12 MHz internal high speed oscillator (HIRC)
- 12 MHz internal high speed RC oscillator (HIRC)
- 10 kHz internal low speed RC oscillator (LIRC)

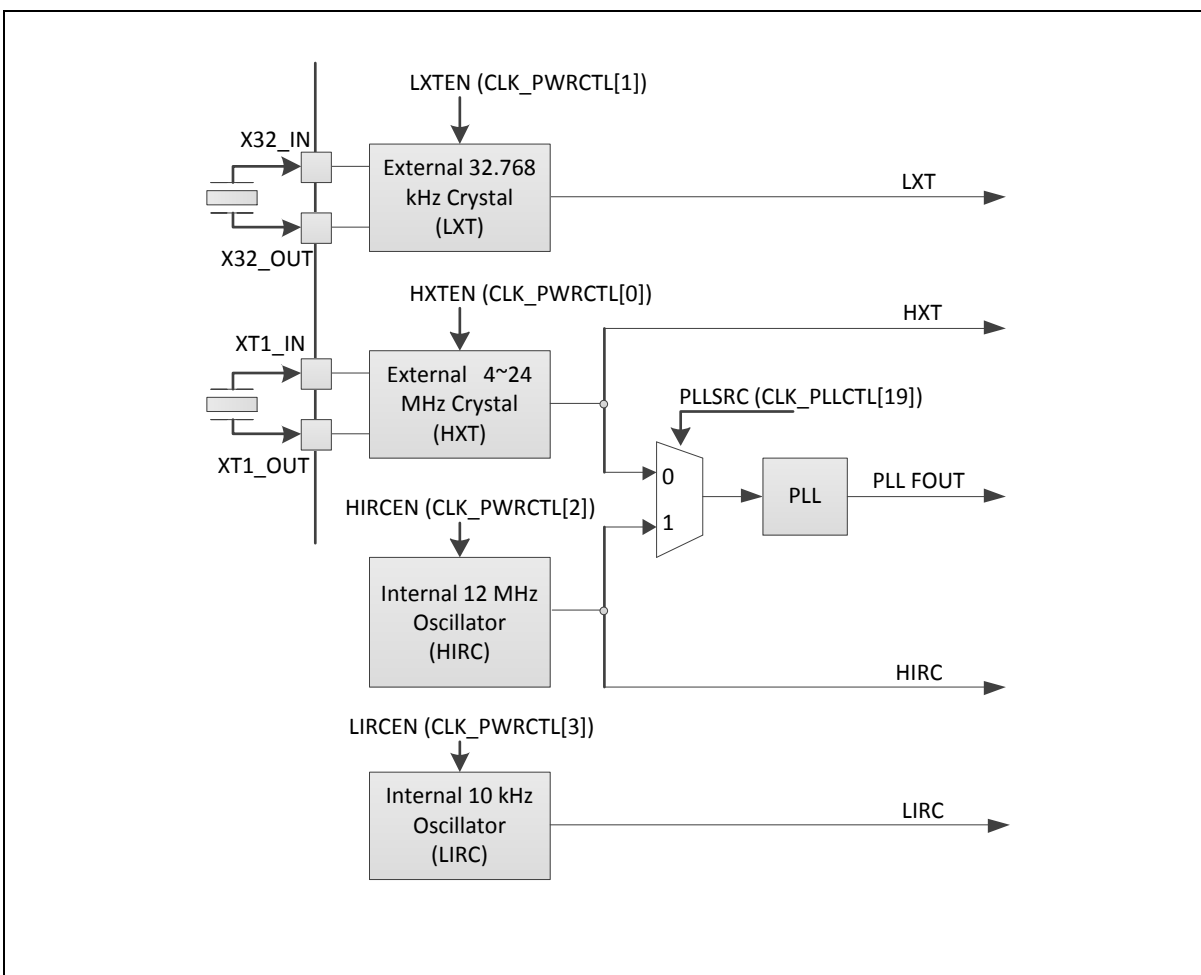

Figure 6.3-2 Clock Generator Block Diagram

6.3.3 System Clock and SysTick Clock

The system clock has 5 clock sources, which were generated from clock generator block. The clock source switch depends on the register HCLKSEL (CLK_CLKSEL0[2:0]). The block diagram is shown in Figure 6.3-3.

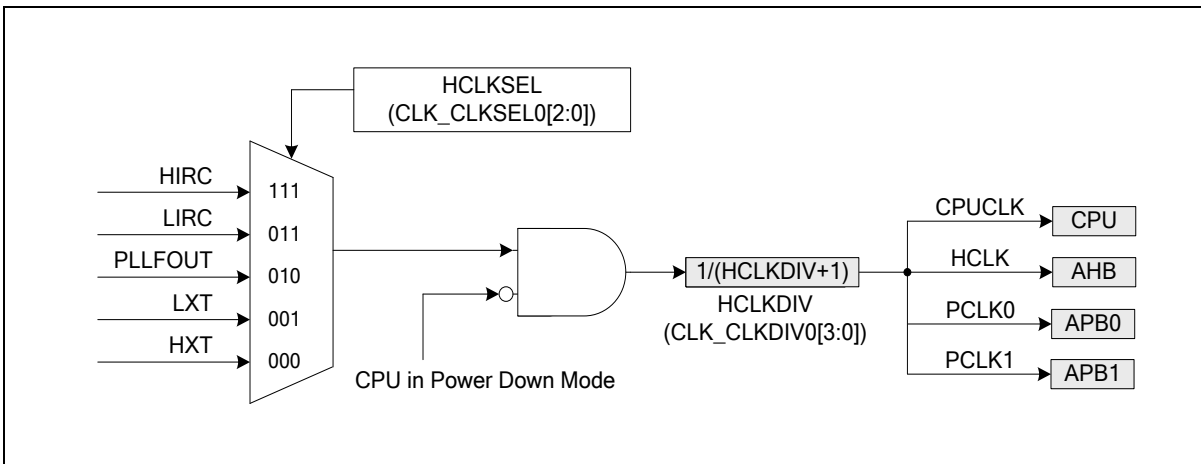

Figure 6.3-3 System Clock Block Diagrams

There are two clock fail detectors to observe HXT and LXT clock source and they have individual enable and interrupt control. When HXT detector is enabled, the HIRC clock is enabled automatically. When LXT detector is enabled, the LIRC clock is enabled automatically.

When HXT clock detector is enabled, the system clock will auto switch to HIRC if HXT clock stop being detected on the following condition: system clock source comes from HXT or system clock source comes from PLL with HXT as the input of PLL. If HXT clock stop condition is detected, the HXTFIF (CLK_CLKDSTS[0]) is set to 1 and chip will enter interrupt if HXTFIE (CLK_CLKDCTL[5]) is set to 1. User can try to recover HXT by disable HXT and enable HXT again to check if the clock stable bit is set to 1 or not. If HXT clock stable bit is set to 1, it means HXT is recover to oscillate after re-enable action and user can switch system clock to HXT again.

Figure 6.3-4 shows the HXT clock stops detection and system clock switches to HIRC procedure.

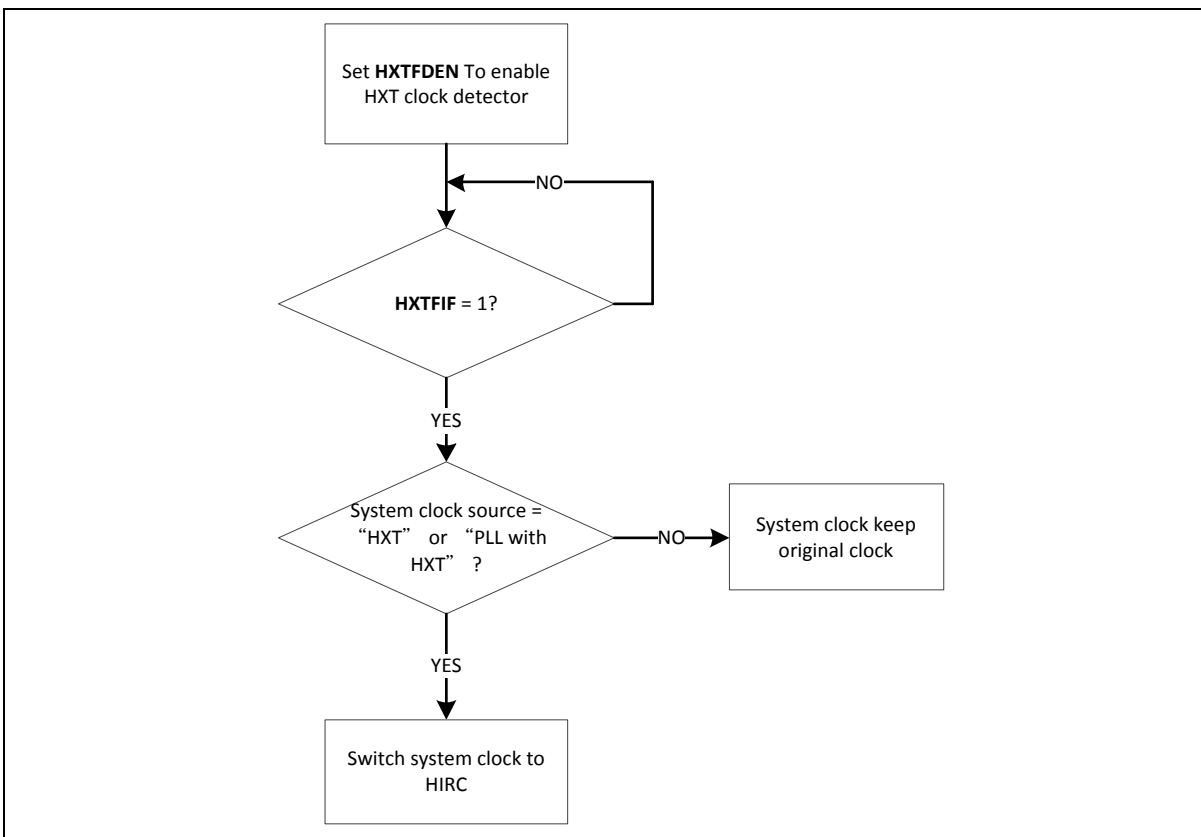

Figure 6.3-4 HXT Stop Protect Procedure

The clock source of SysTick in Cortex[®]-M4 core can use CPU clock or external clock (SYST_CTRL[2]). If using external clock, the SysTick clock (STCLK) has 5 clock sources. The clock source switch depends on the setting of the register STCLKSEL (CLK_CLKSEL0[5:3]). The block diagram is shown in Figure 6.3-5.

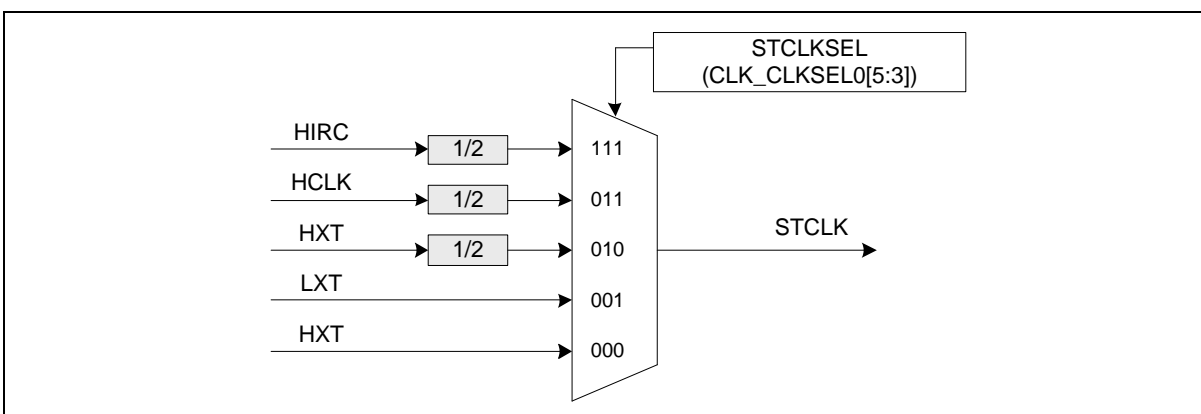

Figure 6.3-5 SysTick Clock Control Block Diagram

6.3.4 Peripherals Clock

Each peripheral clock has its own clock source selection. Refer to the CLK_CLKSEL1, CLK_CLKSEL2 and CLK_CLKSEL3 register.

6.3.5 Power-down Mode Clock

When entering Power-down mode, system clocks, some clock sources and some peripheral clocks are disabled. Some clock sources and peripherals clock are still active in Power-down mode.

For these clocks, which still keep active, are listed below:

- Clock Generator
 - 10 kHz internal low speed RC oscillator (LIRC) clock
 - 32.768 kHz external low speed crystal oscillator (LXT) clock
- Peripherals Clock (When the modules adopt LXT or LIRC as clock source)

6.3.6 Clock Output

This device is equipped with a power-of-2 frequency divider which is composed of 16 chained divide-by-2 shift registers. One of the 16 shift register outputs selected by a sixteen to one multiplexer is reflected to CLKO function pin. Therefore there are 16 options of power-of-2 divided clocks with the frequency from $F_{in}/2^1$ to $F_{in}/2^{16}$ where F_{in} is input clock frequency to the clock divider.

The output formula is $F_{out} = F_{in}/2^{(N+1)}$, where F_{in} is the input clock frequency, F_{out} is the clock divider output frequency and N is the 4-bit value in FREQSEL (CLK_CLKOCTL[3:0]).

When writing 1 to CLKOEN (CLK_CLKOCTL[4]), the chained counter starts to count. When writing 0 to CLKOEN (CLK_CLKOCTL[4]), the chained counter continuously runs till divided clock reaches low state and stays in low state.

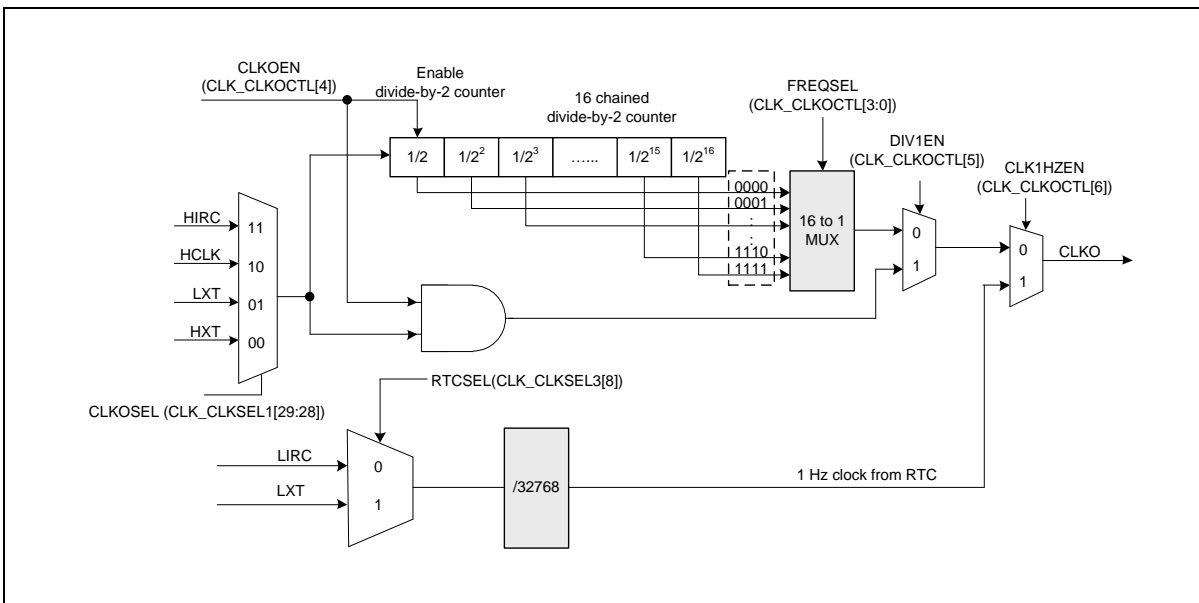

Figure 6.3-6 Clock Output Block Diagram

6.3.7 USB Clock Source

The clock sources of USB 1.0 and 2.0 systems are generated from USB2.0 PHY clock or programmable PLL output. The generated clocks are shown in Figure 6.3-7.

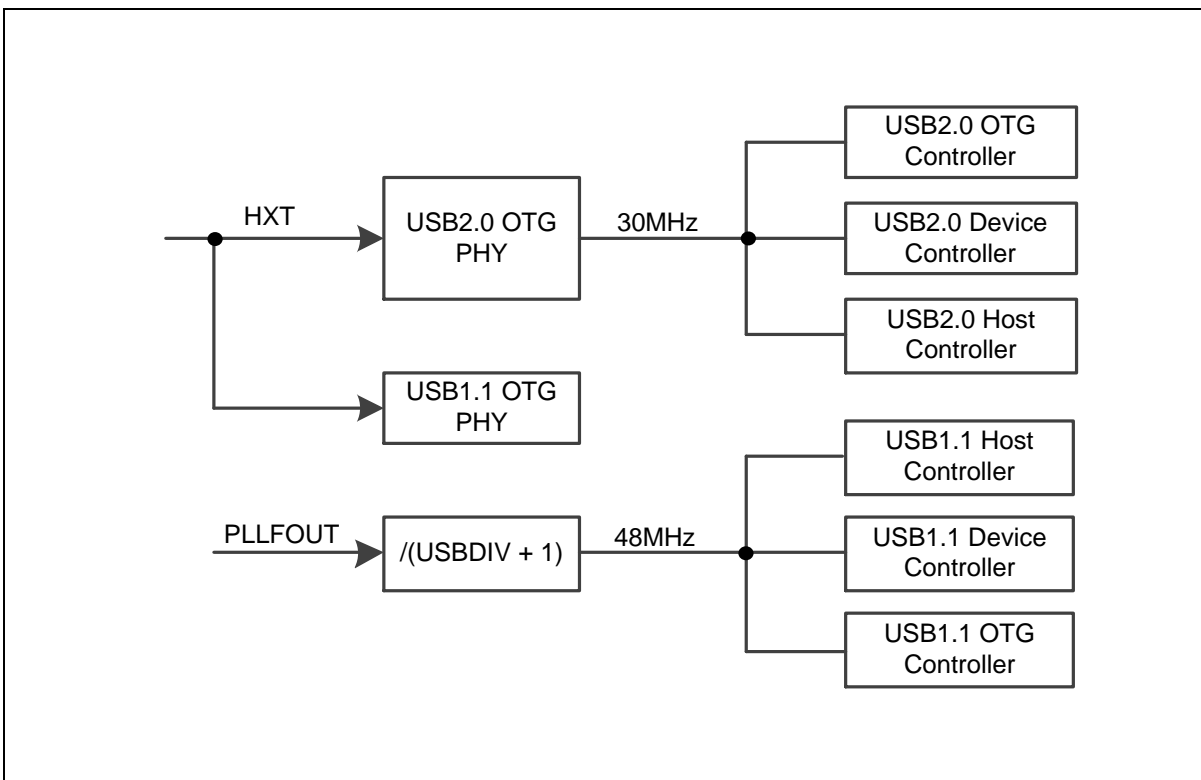

Figure 6.3-7 USB Clock Source

6.4 Flash Memory Controller (FMC)

6.4.1 Overview

The FMC is equipped with dual-bank on-chip embedded Flash (BANK0 and BANK1) for application and configurable Data Flash to store some application dependent data. Both BANK0 and BANK1 have 64/128/256 Kbytes space. Thus, the total size of application rom (APROM) is 128K/256K/512K. A User Configuration block provides for system initiation in BANK0. A 4 Kbytes loader ROM (LDROM) is used for In-System-Programming (ISP) function in BANK0. A 4 Kbytes security protection ROM (SPROM) can conceal user program. A 2 Kbytes one-time-program ROM (OTP) is used for recording one-time-program data in BANK1. A 32K Boot Loader consists of native ISP functions. A 4KB cache with zero wait cycle is used to improve Flash access performance. This chip also supports In-Application-Programming (IAP) function. User switches the code executing without chip reset after the embedded Flash is updated.

6.4.2 Features

- Supports dual-bank Flash macro for safe firmware upgrade
- Supports 128/256/512 Kbytes application ROM (APROM)
- Supports 4 Kbytes loader ROM (LDROM)
- Supports 4 Kbytes security protection ROM (SPROM) to conceal user program
- Supports Data Flash with configurable memory size
- Supports 16 bytes User Configuration block to control system initiation
- Supports 2 Kbytes one-time-program ROM (OTP)
- Supports 4 Kbytes page erase for all embedded Flash
- Supports Boot Loader with native In-System-Programming (ISP) functions
- Supports Security Key protection function for APROM, LDROM, SPROM, User Configuration block and KPROM protection
- Supports 32-bit/64-bit and multi-word Flash programming function
- Supports fast Flash programming verification function
- Supports CRC32 checksum calculation function
- Supports Flash all one verification function
- Supports In-System-Programming (ISP) / In-Application-Programming (IAP) to update embedded Flash memory
- Supports cache memory to improve Flash access performance and reduce power consumption
- Supports auto-tuning Flash access cycle function to optimize the Flash access performance

6.5 General Purpose I/O (GPIO)

6.5.1 Overview

This chip has up to 118 General Purpose I/O pins to be shared with other function pins depending on the chip configuration. These 118 pins are arranged in 8 ports named as PA, PB, PC, PD, PE, PF, PG and PH. PA, PB, PE and PG has 16 pins on port. PC, PD has 15 pins on port. PF, PH has 12 pins on port. Each of the 118 pins is independent and has the corresponding register bits to control the pin mode function and data.

The I/O type of each of I/O pins can be configured by software individually as Input, Push-pull output, Open-drain output or Quasi-bidirectional mode. After the chip is reset, the I/O mode of all pins are depending on CIOINI (CONFIG0[10]).

6.5.2 Features

- Four I/O modes:
 - Quasi-bidirectional mode
 - Push-Pull Output mode
 - Open-Drain Output mode
 - Input only with high impedance mode
- TTL/Schmitt trigger input selectable
- I/O pin can be configured as interrupt source with edge/level setting
- Supports High Drive and High Slew Rate I/O mode
- Configurable default I/O mode of all pins after reset by CIOINI (CONFIG0[10]) setting
 - CIOINI = 0, all GPIO pins in Quasi-bidirectional mode after chip reset
 - CIOINI = 1, all GPIO pins in input mode after chip reset
- I/O pin internal pull-up resistor enabled only in Quasi-bidirectional I/O mode
- Enabling the pin interrupt function will also enable the wake-up function

6.6 PDMA Controller (PDMA)

6.6.1 Overview

The peripheral direct memory access (PDMA) controller is used to provide high-speed data transfer. The PDMA controller can transfer data from one address to another without CPU intervention. This has the benefit of reducing the workload of CPU and keeps CPU resources free for other applications. The PDMA controller has a total of 16 channels and each channel can perform transfer between memory and peripherals or between memory and memory.

6.6.2 Features

- Supports 16 independently configurable channels
- Selectable 2 level of priority (fixed priority or round-robin priority)
- Supports transfer data width of 8, 16, and 32 bits
- Supports source and destination address increment size can be byte, half-word, word or no increment
- Supports software and SPI, UART, DAC, ADC and PWM request
- Supports Scatter-Gather mode to perform sophisticated transfer through the use of the descriptor link list table
- Supports single and burst transfer type
- Supports time-out function on channel 0 and channel1
- Supports stride function from channel 0 to channel 5

6.7 Timer Controller (TMR)

6.7.1 Overview

The timer controller includes four 32-bit timers, Timer0 ~ Timer3, allowing user to easily implement a timer control for applications. The timer can perform functions, such as frequency measurement, delay timing, clock generation, and event counting by external input pins, and interval measurement by external capture pins.

The timer controller also provides four PWM generators. Each PWM generator supports two PWM output channels in independent mode and complementary mode. The output state of PWM output pin can be control by pin mask, polarity and break control, and dead-time generator.

6.7.2 Features

6.7.2.1 Timer Function Features

- Four sets of 32-bit timers, each timer having one 24-bit up counter and one 8-bit prescale counter
- Independent clock source for each timer
- Provides one-shot, periodic, toggle-output and continuous counting operation modes
- 24-bit up counter value is readable through CNT (TIMERx_CNT[23:0])
- Supports event counting function
- 24-bit capture value is readable through CAPDAT (TIMERx_CAP[23:0])
- Supports external capture pin event for interval measurement
- Supports external capture pin event to reset 24-bit up counter
- Supports chip wake-up from Idle/Power-down mode if a timer interrupt signal is generated
- Support Timer0 ~ Timer3 time-out interrupt signal or capture interrupt signal to trigger EPWM, EADC, DAC and PDMA function
- Supports internal capture triggered while internal ACMP output signal transition
- Supports Inter-Timer trigger mode
- Supports event counting source from internal USB SOF signal

6.7.2.2 PWM Function Features

- Supports maximum clock frequency up to maximum PCLK
- Supports independent mode for PWM generator with two output channels
- Supports complementary mode for PWM generator with paired PWM output channel
 - 12-bit dead-time insertion with 12-bit prescale
- Supports 12-bit prescale from 1 to 4096
- Supports 16-bit PWM counter
 - Up, down and up-down count operation type
 - One-shot or auto-reload counter operation mode
- Supports mask function and tri-state enable for each PWM output pin
- Supports brake function
 - Brake source from pin, analog comparator and system safety events (clock failed,

- Brown-out detection, SRAM parity error and CPU lockup)
- Brake pin noise filter control for brake source
- Edge detect brake source to control brake state until brake status cleared
- Level detect brake source to auto recover function after brake condition removed
- Supports interrupt on the following events:
 - PWM zero point, period point, up-count compared or down-count compared point events
 - Brake condition happened
- Supports trigger EADC on the following events:
 - PWM zero point, period, zero or period point, up-count compared or down-count compared point events

6.8 Watchdog Timer (WDT)

6.8.1 Overview

The Watchdog Timer (WDT) is used to perform a system reset when system runs into an unknown state. This prevents system from hanging for an infinite period of time. Besides, this Watchdog Timer supports the function to wake up system from Idle/Power-down mode.

6.8.2 Features

- 18-bit free running up counter for WDT time-out interval
- Selectable time-out interval (24 ~ 218) and the time-out interval is 1.6 ms ~ 26.214 s if WDT_CLK = 10 kHz.
- System kept in reset state for a period of $(1 / \text{WDT_CLK}) * 63$
- Supports selectable WDT reset delay period, including 1026、130、18 or 3 WDT_CLK reset delay period
- Supports to force WDT enabled after chip powered on or reset by setting CWDTEN[2:0] in Config0 register
- Supports WDT time-out wake-up function only if WDT clock source is selected as 10 kHz or LXT.

6.9 Window Watchdog Timer (WWDT)

6.9.1 Overview

The Window Watchdog Timer (WWDT) is used to perform a system reset within a specified window period to prevent software run to uncontrollable status by any unpredictable condition.

6.9.2 Features

- 6-bit down counter value (CNTDAT, WWDT_CNT[5:0]) and 6-bit compare value (CMPDAT, WWDT_CTL[21:16]) to make the WWDT time-out window period flexible
- Supports 4-bit value (PSCSEL, WWDT_CTL[11:8]) to programmable maximum 11-bit prescale counter period of WWDT counter
- WWDT counter suspends in Idle/Power-down mode

6.10 Real Time Clock (RTC)

6.10.1 Overview

The Real Time Clock (RTC) controller provides the real time and calendar message. The RTC offers programmable time tick and alarm match interrupts. The data format of time and calendar messages are expressed in BCD format. A digital frequency compensation feature is available to compensate external crystal oscillator frequency accuracy.

6.10.2 Features

- Supports real time counter in RTC_TIME (hour, minute, second) and calendar counter in RTC_CAL (year, month, day) for RTC time and calendar check.
- Supports alarm time (hour, minute, second) and calendar (year, month, day) settings in RTC_TALM and RTC_CALM.
- Supports alarm time (hour, minute, second) and calendar (year, month, day) mask enable in RTC_TAMSK and RTC_CAMSK.
- Selectable 12-hour or 24-hour time scale in RTC_CLKFMT register.
- Supports Leap Year indication in RTC_LEAPYEAR register.
- Supports Day of the Week counter in RTC_WEEKDAY register.
- Frequency of RTC clock source compensate by RTC_FREQADJ register.
- All time and calendar message expressed in BCD format.
- Supports periodic RTC Time Tick interrupt with 8 period interval options 1/128, 1/64, 1/32, 1/16, 1/8, 1/4, 1/2 and 1 second.
- Supports RTC Time Tick and Alarm Match interrupt.
- Supports 1 Hz clock output.
- Supports chip wake-up from Idle or Power-down mode while a RTC interrupt signal is generated.
- Supports Daylight Saving Time software control in RTC_DSTCTL.
- Supports up to 3 pairs dynamic loop tamper pin or 6 individual tamper pin.
- Supports 80 bytes spare registers and tamper pins detection to clear the content of these spare registers.

6.11 EPWM Generator and Capture Timer (EPWM)

6.11.1 Overview

The chip provides two EPWM generators — EPWM0 and EPWM1. Each EPWM supports 6 channels of EPWM output or input capture. There is a 12-bit prescaler to support flexible clock to the 16-bit EPWM counter with 16-bit comparator. The EPWM counter supports up, down and up-down counter types. EPWM uses comparator compared with counter to generate events. These events use to generate EPWM pulse, interrupt and trigger signal for EADC/DAC to start conversion.

The EPWM generator supports two standard EPWM output modes: Independent mode and Complementary mode, they have difference architecture. There are two output functions based on standard output modes: Group function and Synchronous function. Group function can be enabled under Independent mode or complementary mode. Synchronous function only enabled under complementary mode. Complementary mode has two comparators to generate various EPWM pulse with 12-bit dead-time generator and another free trigger comparator to generate trigger signal for EADC. For EPWM output control unit, it supports polarity output, independent pin mask and brake functions.

The EPWM generator also supports input capture function. It supports latch EPWM counter value to corresponding register when input channel has a rising transition, falling transition or both transition is happened. Capture function also support PDMA to transfer captured data to memory.

6.11.2 Features

6.11.2.1 EPWM Function Features

- Supports maximum clock frequency up to maximum PLL frequency
- Supports up to two EPWM modules, each module provides 6 output channels
- Supports independent mode for EPWM output/Capture input channel
- Supports complementary mode for 3 complementary paired EPWM output channel
 - Dead-time insertion with 12-bit resolution
 - Synchronous function for phase control
 - Two compared values during one period
- Supports 12-bit prescaler from 1 to 4096
- Supports 16-bit resolution EPWM counter

Up, down and up/down counter operation type

- Supports one-shot or auto-reload counter operation mode
- Supports group function
- Supports synchronous function
- Supports mask function and tri-state enable for each EPWM pin
- Supports brake function
 - Brake source from pin, analog comparator and system safety events (clock failed, SRAM parity error, Brown-out detection and CPU lockup).
 - Noise filter for brake source from pin
 - Leading edge blanking (LEB) function for brake source from analog comparator
 - Edge detect brake source to control brake state until brake interrupt cleared
 - Level detect brake source to auto recover function after brake condition removed

- Supports interrupt on the following events:
 - EPWM counter matches 0, period value or compared value
 - Brake condition happened
- Supports trigger EADC/DAC on the following events:
 - EPWM counter matches 0, period value or compared value
 - EPWM counter match free trigger comparator compared value (only for EADC)

6.11.2.2 Capture Function Features

- Supports up to 12 capture input channels with 16-bit resolution
- Supports rising or falling capture condition
- Supports input rising/falling capture interrupt
- Supports rising/falling capture with counter reload option
- Supports PDMA transfer function for EPWM all channels

6.12 Basic PWM Generator and Capture Timer (BPWM)

6.12.1 Overview

The chip provides two BPWM generators — BPWM0 and BPWM1. Each BPWM supports 6 channels of BPWM output or input capture. There is a 12-bit prescaler to support flexible clock to the 16-bit BPWM counter with 16-bit comparator. The BPWM counter supports up, down and up-down counter types, all 6 channels share one counter. BPWM uses the comparator compared with counter to generate events. These events are used to generate BPWM pulse, interrupt and trigger signal for EADC to start conversion. For BPWM output control unit, it supports polarity output, independent pin mask and tri-state output enable.

The BPWM generator also supports input capture function to latch BPWM counter value to corresponding register when input channel has a rising transition, falling transition or both transition is happened.

6.12.2 Features

6.12.2.1 BPWM Function Features

- Supports maximum clock frequency up to maximum PLL frequency.
- Supports up to two BPWM modules; each module provides 6 output channels
- Supports independent mode for BPWM output/Capture input channel
- Supports 12-bit prescaler from 1 to 4096
- Supports 16-bit resolution BPWM counter; each module provides 1 BPWM counter
 - Up, down and up/down counter operation type
- Supports mask function and tri-state enable for each BPWM pin
- Supports interrupt in the following events:
 - BPWM counter matches 0, period value or compared value
- Supports trigger EADC in the following events:
 - BPWM counter matches 0, period value or compared value

6.12.2.2 Capture Function Features

- Supports up to 12 capture input channels with 16-bit resolution
- Supports rising or falling capture condition
- Supports input rising/falling capture interrupt
- Supports rising/falling capture with counter reload option

6.13 Quadrature Encoder Interface (QEI)

6.13.1 Overview

There are two QEI controllers in this device. The Quadrature Encoder Interface (QEI) decodes speed of rotation and motion sensor information. It can be used in any application that uses a quadrature encoder for feedback.

6.13.2 Features

6.13.2.1 Quadrature Encoder Interface (QEI) Features

- Up to two QEI controllers, QEI0 and QEI1.
- Two QEI phase inputs, QEA and QEB; One Index input.
- A 32-bit up/down Quadrature Encoder Pulse Counter (QEI_CNT)
- A 32-bit software-latch Quadrature Encoder Pulse Counter Hold Register (QEI_CNTHOLD)
- A 32-bit Quadrature Encoder Pulse Counter Index Latch Register (QEI_CNTRLATCH)
- A 32-bit Quadrature Encoder Pulse Counter Compare Register (QEI_CNTCMP) with a Pre-set Maximum Count Register (QEI_CNTMAX)
- One QEI control register (QEI_CTL) and one QEI Status Register (QEI_STATUS)
- Four Quadrature encoder pulse counter operation modes
 - Support x4 free-counting mode
 - Support x2 free-counting mode
 - Support x4 compare-counting mode
 - Support x2 compare-counting mode
- Encoder Pulse Width measurement mode
- Input frequency of QEA/QEB/IDX without noise filter must lower than PCLK/4
- Input frequency of QEA/QEB/IDX with noise filter must lower than Noise Filter Clk/8

6.14 Enhanced Input Capture Timer (ECAP)

6.14.1 Overview

This device provides up to two units of Input Capture Timer/Counter whose capture function can detect the digital edge-changed signal at channel inputs. Each unit has three input capture channels. The timer/counter is equipped with up counting, reload and compare-match capabilities.

6.14.2 Features

- Up to two Input Capture Timer/Counter units, CAP0 and CAP1.
- Each unit has 3 input channels.
- Each unit has its own interrupt vector.
- Each input channel has its own capture counter hold register.
- 24-bit Input Capture up-counting timer/counter.
- With noise filter in front end of input ports.
- Edge detector with three options:
 - Rising edge detection
 - Falling edge detection
 - Both edge detection
- Captured events reset and/or reload capture counter.
- Supports compare-match function.

6.15 UART Interface Controller (UART)

6.15.1 Overview

The chip provides six channels of Universal Asynchronous Receiver/Transmitters (UART). The UART controller performs Normal Speed UART and supports flow control function. The UART controller performs a serial-to-parallel conversion on data received from the peripheral and a parallel-to-serial conversion on data transmitted from the CPU. Each UART controller channel supports ten types of interrupts. The UART controller also supports IrDA SIR, LIN and RS-485 function modes and auto-baud rate measuring function.

6.15.2 Features

- Full-duplex asynchronous communications
- Separates receive and transmit 16/16 bytes entry FIFO for data payloads
- Supports hardware auto-flow control
- Programmable receiver buffer trigger level
- Supports programmable baud rate generator for each channel individually
- Supports nCTS, incoming data, Received Data FIFO reached threshold and RS-485 Address Match (AAD mode) wake-up function
- Supports 8-bit receiver buffer time-out detection function
- Programmable transmitting data delay time between the last stop and the next start bit by setting DLY (UART_TOUT [15:8])
- Supports Auto-Baud Rate measurement and baud rate compensation function
 - Support 9600 bps for UART_CLK is selected LXT.
- Supports break error, frame error, parity error and receive/transmit buffer overflow detection function
- Fully programmable serial-interface characteristics
 - Programmable number of data bit, 5-, 6-, 7-, 8- bit character
 - Programmable parity bit, even, odd, no parity or stick parity bit generation and detection
 - Programmable stop bit, 1, 1.5, or 2 stop bit generation
- Supports IrDA SIR function mode
 - Supports for 3/16 bit duration for normal mode
- Supports LIN function mode (Only UART0 /UART1 with LIN function)
 - Supports LIN master/slave mode
 - Supports programmable break generation function for transmitter
 - Supports break detection function for receiver
- Supports RS-485 function mode
 - Supports RS-485 9-bit mode
 - Supports hardware or software enables to program nRTS pin to control RS-485 transmission direction
- Supports PDMA transfer function

UART Feature	UART0/ UART1	UART2/ UART4/ UART5	UART3/ SC_UART	USCI-UART
FIFO	16 Bytes	16 Bytes	4 Bytes	TX: 1byte RX: 2byte
Auto Flow Control (CTS/RTS)	√	√	-	√
IrDA	√	√	-	-
LIN	√	-	-	-
RS-485 Function Mode	√	√	-	√
nCTS Wake-up	√	√	-	√
Imcoming Data Wake-up	√	√	-	√
Received Data FIFO reached threshold Wake-up	√	√	-	-
RS-485 Address Match (AAD mode) Wake-up	√	√	-	-
Auto-Baud Rate Measurement	√	√	-	√
STOP Bit Length	1, 1.5, 2 bit	1, 1.5, 2 bit	1, 2 bit	1, 2 bit
Word Length	5, 6, 7, 8 bits	5, 6, 7, 8 bits	5, 6, 7, 8 bits	6~13 bits
Even / Odd Parity	√	√	√	√
Stick Bit	√	√	-	-
Note: √= Supported				

Table 6.15-1 NuMicro[®] M480 Series UART Features

6.16 Ethernet MAC Controller (EMAC)

6.16.1 Overview

This chip provides an Ethernet MAC Controller (EMAC) for Network application. The Ethernet MAC controller consists of IEEE 802.3/Ethernet protocol engine with internal CAM function for recognizing Ethernet MAC addresses, Transmit-FIFO, Receive-FIFO, TX/RX state machine controller, time stamping engine for IEEE 1588, Magic Packet parsing engine and status controller. The EMAC supports both the MII and RMII (Reduced MII) interface to connect with external Ethernet PHY.

6.16.2 Features

- Supports IEEE Std. 802.3 CSMA/CD protocol
- Supports Ethernet frame time stamping for IEEE Std. 1588 – 2002 protocol
- Supports both half and full duplex for 10 Mbps or 100 Mbps operation
- Supports both MII and RMII interface
- Supports MII Management function to control external Ethernet PHY
- Supports pause and remote pause function for flow control
- Supports long frame (more than 1518 bytes) and short frame (less than 64 bytes) reception
- Supports 16 entries CAM function for Ethernet MAC address recognition
- Supports Magic Packet recognition to wake system up from Power-down mode
- Supports 256 bytes transmit FIFO and 256 bytes receive FIFO
- Supports DMA function

6.17 Smart Card Host Interface (SC)

6.17.1 Overview

The Smart Card Interface controller (SC controller) is based on ISO/IEC 7816-3 standard and fully compliant with PC/SC Specifications. It also provides status of card insertion/removal.

6.17.2 Features

- ISO 7816-3 T = 0, T = 1 compliant
- EMV2000 compliant
- Three ISO 7816-3 ports
- Separates receive/transmit 4 byte entry FIFO for data payloads
- Programmable transmission clock frequency
- Programmable receiver buffer trigger level
- Programmable guard time selection (11 ETU ~ 267 ETU)
- One 24-bit timer and two 8-bit timers for Answer to Request (ATR) and waiting times processing
- Supports auto direct / inverse convention function
- Supports transmitter and receiver error retry and error number limiting function
- Supports hardware activation sequence process, and the time between PWR on and CLK start is configurable
- Supports hardware warm reset sequence process
- Supports hardware deactivation sequence process
- Supports hardware auto deactivation sequence when detected the card removal
- Supports UART mode
 - Full duplex, asynchronous communications
 - Separates receiving / transmitting 4 bytes entry FIFO for data payloads
 - Supports programmable baud rate generator
 - Supports programmable receiver buffer trigger level
 - Programmable transmitting data delay time between the last stop bit leaving the TX-FIFO and the de-assertion by setting EGT (SCn_EGT[7:0])
 - Programmable even, odd or no parity bit generation and detection
 - Programmable stop bit, 1- or 2- stop bit generation

6.18 I²S Controller (I²S)

6.18.1 Overview

The I²S controller consists of I²S protocol to interface with external audio CODEC. Two 16-level depth FIFO for reading path and writing path respectively are capable of handling 8/16/24/32 bits audio data sizes. A PDMA controller handles the data movement between FIFO and memory.

6.18.2 Features

- Supports Master mode and Slave mode
- Capable of handling 8, 16, 24 and 32 bits data sizes in each audio channel
- Supports monaural and stereo audio data
- Supports I²S protocols: Philips standard, MSB-justified, and LSB-justified data format
- Supports PCM protocols: PCM standard, MSB-justified, and LSB-justified data format
- PCM protocol supports TDM multi-channel transmission in one audio sample, and the number of data channel can be set as 2, 4, 6, or 8
- Provides two 16-level FIFO data buffers, one for transmitting and the other for receiving
- Generates interrupt requests when buffer levels cross a programmable boundary
- Supports two PDMA requests, one for transmitting and the other for receiving

6.19 Serial Peripheral Interface (SPI)

6.19.1 Overview

The Serial Peripheral Interface (SPI) applies to synchronous serial data communication and allows full duplex transfer. Devices communicate in Master/Slave mode with the 4-wire bi-direction interface. The M480 series contains up to four sets of SPI controllers performing a serial-to-parallel conversion on data received from a peripheral device, and a parallel-to-serial conversion on data transmitted to a peripheral device. Each SPI controller can be configured as a master or a slave device and supports the PDMA function to access the data buffer. Each SPI controller also supports I²S mode to connect external audio CODEC.

6.19.2 Features

- SPI Mode
 - Up to four sets of SPI controllers
 - Supports Master or Slave mode operation
 - Master mode up to 100 MHz and Slave mode up to 100 MHz (when chip works at V_{DD} = 2.7~3.6V)
 - Configurable bit length of a transaction word from 8 to 32-bit
 - Provides separate 4-level depth transmit and receive FIFO buffers
 - Supports MSB first or LSB first transfer sequence
 - Supports Byte Reorder function
 - Supports Byte or Word Suspend mode
 - Supports PDMA transfer
 - Supports one data channel half-duplex transfer
 - Supports receive-only mode
- I²S Mode
 - Supports Master or Slave
 - Capable of handling 8-, 16-, 24- and 32-bit word sizes
 - Each provides two 4-level FIFO data buffers, one for transmitting and the other for receiving
 - Supports monaural and stereo audio data
 - Supports PCM mode A, PCM mode B, I²S and MSB justified data format
 - Supports two PDMA requests, one for transmitting and the other for receiving

	QSPIx	SPIx
Dual/Quad I/O Mode	V	X
Two-bit Transfer Mode	V	X
FIFO Depth	8-level	SPI mode 8~16 bits data length: 8-level Otherwise: 4-level
Slave Time-out Function	V	X
Slave 3-Wired Mode	V	X

I ² S Mode	X	V
-----------------------	---	---

6.20 Quad Serial Peripheral Interface (QSPI)

6.20.1 Overview

The Quad Serial Peripheral Interface (QSPI) applies to synchronous serial data communication and allows full duplex transfer. Devices communicate in Master/Slave mode with the 4-wire bi-direction interface. The M480 series contains one QSPI controller performing a serial-to-parallel conversion on data received from a peripheral device, and a parallel-to-serial conversion on data transmitted to a peripheral device.

The QSPI controller supports 2-bit Transfer mode to perform full-duplex 2-bit data transfer and also supports Dual and Quad I/O Transfer mode and the controller supports the PDMA function to access the data buffer.

6.20.2 Features

- Supports Master or Slave mode operation
- Master mode up to 100 MHz and Slave mode up to 100 MHz (when chip works at $V_{DD} = 2.7\sim 3.6V$)
- Supports 2-bit Transfer mode
- Supports Dual and Quad I/O Transfer mode
- Configurable bit length of a transaction word from 8 to 32-bit
- Provides separate 8-level depth transmit and receive FIFO buffers
- Supports MSB first or LSB first transfer sequence
- Supports Byte Reorder function
- Supports Byte or Word Suspend mode
- Supports PDMA transfer
- Supports 3-Wire, no slave selection signal, bi-direction interface
- Supports one data channel half-duplex transfer
- Supports receive-only mode

6.21 SPI Synchronous Serial Interface Controller (SPI Master mode)

6.21.1 Overview

The SPI Synchronous serial Interface Controller for SPI master mode performs a serial-to-parallel conversion on data received from the peripheral, and a parallel-to-serial conversion on data received from MCU. This SPI controller can drive one external peripheral (External SPI Flash) and it is seen as the SPI master mode. It can generate an interrupt signal when data transfer is finished and can be cleared by writing 1 to the interrupt flag. The active level of device/slave select signal can be chosen to low active or high active, which depends on the peripheral. Writing a divisor into the SPIM_CTL1 register can program the frequency of serial clock output to the peripheral.

In SPI Flash controller, normal I/O mode contains four 32-bit transmit/receive buffers, and can provide 1 to 4 burst mode operation. The number of bits in each transaction can be 8, 16, 24, or 32; data can be transmitted/received up to four successive transactions in one transfer.

By DMA write mode, user can move data from SRAM to external SPI Flash component. In DMA read mode, user can move data from external SPI Flash component to SRAM. In direct memory mapping mode (DMM mode), this SPI Flash controller will translate the AHB bus commands into SPI Flash operations without MCU setting related SPI Flash command. Therefore users can access external SPI Flash as a ROM module.

In direct memory mapping mode with cache off mode, it will pre-fetch 4-word Flash data after a direct memory mapping access. when using direct memory mapping mode with cache on mode, it will use 32 Kbytes cache memory to reduce the number of accessing external SPI Flash component and the performance of SPI Flash access can be improved. To improve the read operation of SPI Flash without increasing the serial clock frequency, this SPI Flash controller supports DTR/DDR (Double Transfer Rate/Double Data Rate) read command codes that support Standard/Dual/Quad SPI modes. The one byte command code is still latched into the device on the rising edge of the serial clock similar to all other SPI commands. Once a DTR/DDR instruction code is accepted by the device, the address input and data output will be latched on both rising and falling edges of the serial clock.

In core coupled memory mode (CCM mode), the cache function is disabled by hardware automatically, and MCU can access this 32 Kbytes cache memory as general SRAM. For data protection, this SPI Flash controller supports cipher encryption and decryption circuits to protect data which user places into external SPI Flash when DMA read/write mode and direct memory mapping mode are used.

6.21.2 Features

- Supports maximum 32M bytes SPI Flash size
- Supports SPI master mode
- Supports Direct Memory Mapping Mode and Normal I/O Mode
- Supports 8/16/24/32 bits transaction for Normal I/O mode
- Provides burst mode operation in Normal I/O mode, which can transmit/receive data up to four successive transactions in one transfer
- Supports DMA mode read/write
- Supports standard (1-bit), dual (2-bit), and quad (4-bit) I/O transfer mode
- Supports Double Transfer Rate (DTR) / Double Data Rate (DDR) transfer mode
- Supports 32 Kbytes cache memory
- Supports 32 Kbytes Core Coupled Memory (CCM) when cache function disable
- Supports Cipher encryption/decryption
- One slave/device select line for external SPI Flash component

6.22 I²C Serial Interface Controller (I²C)

6.22.1 Overview

I²C is a two-wire, bi-directional serial bus that provides a simple and efficient method of data exchange between devices. The I²C standard is a true multi-master bus including collision detection and arbitration that prevents data corruption if two or more masters attempt to control the bus simultaneously.

There are two sets of I²C controllers which support Power-down wake-up function.

6.22.2 Features

The I²C bus uses two wires (SDA and SCL) to transfer information between devices connected to the bus. The main features of the I²C bus include:

- Supports up to three I²C ports
- Master/Slave mode
- Bidirectional data transfer between masters and slaves
- Multi-master bus (no central master)
- Supports Standard mode (100 kbps), Fast mode (400 kbps) and Fast mode plus (1 Mbps)
- Arbitration between simultaneously transmitting masters without corruption of serial data on the bus
- Serial clock synchronization allow devices with different bit rates to communicate via one serial bus
- Serial clock synchronization used as a handshake mechanism to suspend and resume serial transfer
- Built-in 14-bit time-out counter requesting the I²C interrupt if the I²C bus hangs up and timer-out counter overflows
- Programmable clocks allow for versatile rate control
- Supports 7-bit addressing and 10-bit addressing mode
- Supports multiple address recognition (four slave address with mask option)
- Supports Power-down wake-up function
- Supports PDMA with one buffer capability
- Supports setup/hold time programmable
- Supports Bus Management (SM/PM compatible) function

6.23 USCI - Universal Serial Control Interface Controller (USCI)

6.23.1 Overview

The Universal Serial Control Interface (USCI) is a flexible interface module covering several serial communication protocols. The user can configure this controller as UART, SPI, or I²C functional protocol.

6.23.2 Features

The controller can be individually configured to match the application needs. The following protocols are supported:

- UART
- SPI
- I²C

6.24 USCI – UART Mode

6.24.1 Overview

The asynchronous serial channel UART covers the reception and the transmission of asynchronous data frames. It performs a serial-to-parallel conversion on data received from the peripheral, and a parallel-to-serial conversion on data transmitted from the controller. The receiver and transmitter being independent, frames can start at different points in time for transmission and reception.

The UART controller also provides auto flow control. There are two conditions to wake-up the system.

6.24.2 Features

- Supports one transmit buffer and two receive buffer for data payload
- Supports hardware auto flow control function
- Supports programmable baud-rate generator
- Support 9-bit Data Transfer (Support 9-bit RS-485)
- Baud rate detection possible by built-in capture event of baud rate generator
- Supports PDMA capability
- Supports Wake-up function (Data and nCTS Wakeup Only)

6.25 USCI - SPI Mode

6.25.1 Overview

The SPI protocol of USCI controller applies to synchronous serial data communication and allows full duplex transfer. It supports both master and Slave operation mode with the 4-wire bi-direction interface. SPI mode of USCI controller performs a serial-to-parallel conversion on data received from a peripheral device, and a parallel-to-serial conversion on data transmitted to a peripheral device. The SPI mode is selected by FUNMODE (USCI_CTL[2:0]) = 0x1

This SPI protocol can operate as master or Slave mode by setting the SLAVE (USCI_PROTCTL[0]) to communicate with the off-chip SPI Slave or master device. The application block diagrams in master and Slave mode are shown below.

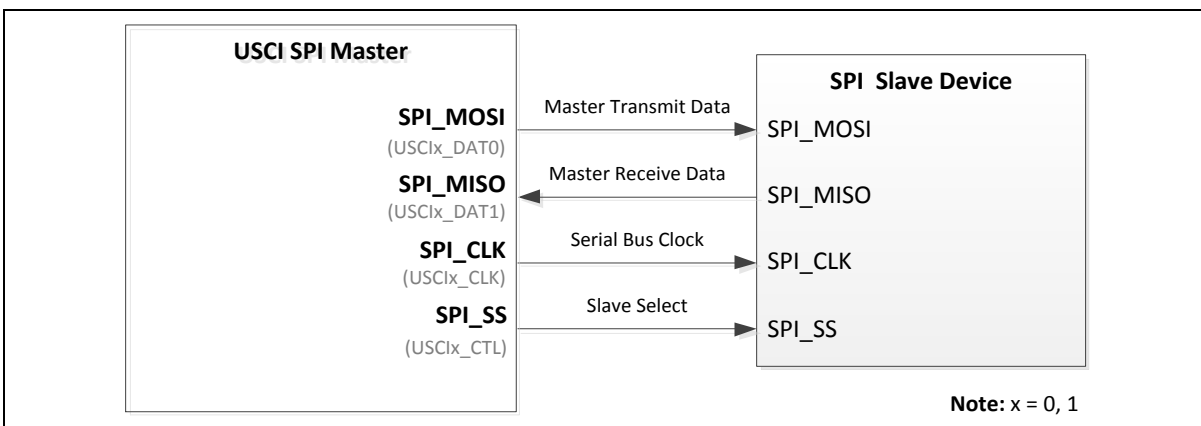

Figure 6.25-1 SPI Master Mode Application Block Diagram

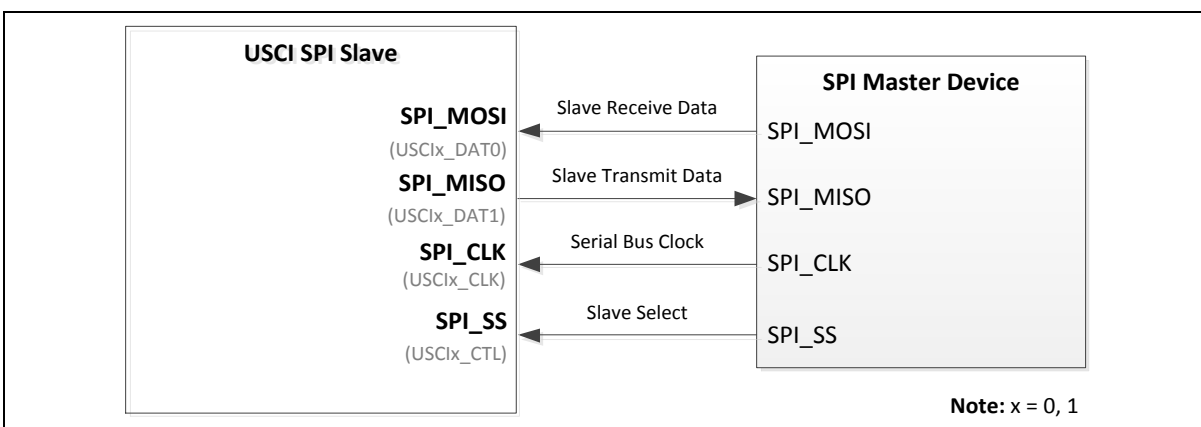

Figure 6.25-2 SPI Slave Mode Application Block Diagram

6.25.2 Features

- Supports Master or Slave mode operation (the maximum frequency -- Master = fPCLK / 2, Slave < fPCLK / 5)
- Configurable bit length of a transfer word from 4 to 16-bit
- Supports one transmit buffer and two receive buffers for data payload
- Supports MSB first or LSB first transfer sequence

- Supports Word Suspend function
- Supports PDMA transfer
- Supports 3-wire, no slave select signal, bi-direction interface
- Supports wake-up function by slave select signal in Slave mode
- Supports one data channel half-duplex transfer

6.26 USCI - I²C Mode

6.26.1 Overview

On I²C bus, data is transferred between a Master and a Slave. Data bits transfer on the SCL and SDA lines are synchronously on a byte-by-byte basis. Each data byte is 8-bit. There is one SCL clock pulse for each data bit with the MSB being transmitted first, and an acknowledge bit follows each transferred byte. Each bit is sampled during the high period of SCL; therefore, the SDA line may be changed only during the low period of SCL and must be held stable during the high period of SCL. A transition on the SDA line while SCL is high is interpreted as a command (START or STOP). Please refer to Figure 6.26-1 for more detailed I²C BUS Timing.

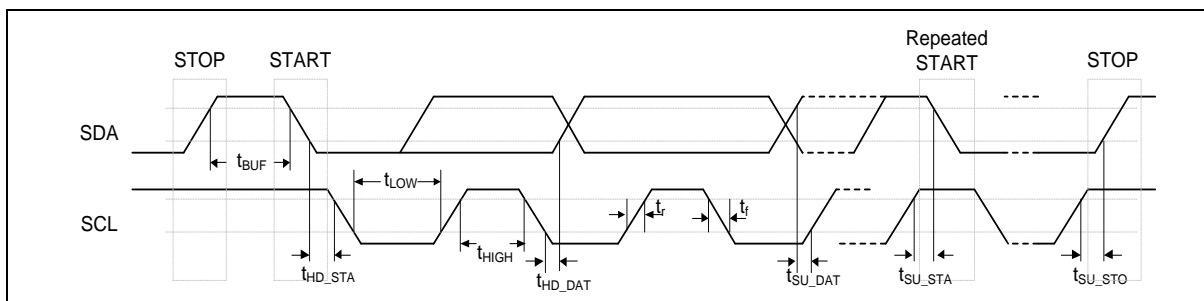

Figure 6.26-1 I²C Bus Timing

The device's on-chip I²C provides the serial interface that meets the I²C bus standard mode specification. The I²C port handles byte transfers autonomously. The I²C mode is selected by FUNMODE (USCI_CTL [2:0]) = 100B. When enable this port, the USCI interfaces to the I²C bus via two pins: SDA and SCL. When I/O pins are used as I²C ports, user must set the pins function to I2C in advance.

Note: Pull-up resistor is needed for I²C operation because the SDA and SCL are set to open-drain pins when USCI is selected to I²C operation mode .

6.26.2 Features

- Full master and slave device capability
- Supports of 7-bit addressing, as well as 10-bit addressing
- Communication in standard mode (100 kBit/s) or in fast mode (up to 400 kBit/s)
- Supports multi-master bus
- Supports one transmit buffer and two receive buffer for data payload
- Supports 10-bit bus time-out capability
- Supports bus monitor mode.
- Supports Power down wake-up by data toggle or address match
- Supports setup/hold time programmable
- Supports multiple address recognition (two slave address with mask option)

6.27 Controller Area Network (CAN)

6.27.1 Overview

The C_CAN consists of the CAN Core, Message RAM, Message Handler, Control Registers and Module Interface. The CAN Core performs communication according to the CAN protocol version 2.0 part A and B. The bit rate can be programmed to values up to 1MBit/s. For the connection to the physical layer, additional transceiver hardware is required.

For communication on a CAN network, individual Message Objects are configured. The Message Objects and Identifier Masks for acceptance filtering of received messages are stored in the Message RAM. All functions concerning the handling of messages are implemented in the Message Handler. These functions include acceptance filtering, the transfer of messages between the CAN Core and the Message RAM, and the handling of transmission requests as well as the generation of the module interrupt.

The register set of the C_CAN can be accessed directly by the software through the module interface. These registers are used to control/configure the CAN Core and the Message Handler and to access the Message RAM.

6.27.2 Features

- Supports CAN protocol version 2.0 part A and B
- Bit rates up to 1 MBit/s
- 32 Message Objects
- Each Message Object has its own identifier mask
- Programmable FIFO mode (concatenation of Message Objects)
- Maskable interrupt
- Disabled Automatic Re-transmission mode for Time Triggered CAN applications
- Programmable loop-back mode for self-test operation
- 16-bit module interfaces to the AMBA APB bus
- Supports wake-up function

6.28 Secure Digital Host Controller (SDH)

6.28.1 Overview

The Secure Digital Host Controller (SD Host) has DMAC unit and SD unit. The DMAC unit provides a DMA (Direct Memory Access) function for SD to exchange data between system memory and shared buffer (128 bytes), and the SD unit controls the interface of SD/SDHC. The SDHOST controller can support SD/SDHC and cooperated with DMAC to provide a fast data transfer between system memory and cards.

6.28.2 Features

- AMBA AHB master/slave interface compatible, for data transfer and register read/write.
- Supports single DMA channel.
- Supports hardware Scatter-Gather function.
- Using single 128 Bytes shared buffer for data exchange between system memory and cards.
- Synchronous design for DMA with single clock domain, AHB bus clock (HCLK).
- Interface with DMAC for register read/write and data transfer.
- Supports SD/SDHC card.
- Completely asynchronous design for Secure Digital with two clock domains, HCLK and Engine clock, note that frequency of HCLK should be higher than the frequency of peripheral clock.

6.29 External Bus Interface (EBI)

6.29.1 Overview

This chip is equipped with an external bus interface (EBI) for external device use. To save the connections between an external device and a chip, EBI is operating at address bus and data bus multiplex mode. The EBI supports three chip selects that can connect three external devices with different timing setting requirements.

6.29.2 Features

- Supports up to three memory banks
- Supports dedicated external chip select pin with polarity control for each bank
- Supports accessible space up to 1 Mbytes for each bank, actually external addressable space is dependent on package pin out
- Supports 8-/16-bit data width
- Supports byte write in 16-bit data width mode
- Supports Address/Data multiplexed Mode
- Supports Timing parameters individual adjustment for each memory block
- Supports LCD interface i80 mode
- Supports PDMA mode
- Supports variable external bus base clock (MCLK) which based on HCLK
- Supports configurable idle cycle for different access condition: Idle of Write command finish (W2X) and Idle of Read-to-Read (R2R)
- Supports address bus and data bus separate mode

6.30 USB 1.1 Device Controller (USBD)

6.30.1 Overview

There is one set of USB 2.0 full-speed device controller and transceiver in this device. It is compliant with USB 2.0 full-speed device specification and supports control/bulk/interrupt/ isochronous transfer types.

In this device controller, there are two main interfaces: the APB bus and USB bus which comes from the USB PHY transceiver. For the APB bus, the CPU can program control registers through it. There are 1KBytes internal SRAM as data buffer in this controller. For IN or OUT transfer, it is necessary to write data to SRAM or read data from SRAM through the APB interface or SIE. User needs to set the effective starting address of SRAM for each endpoint buffer through buffer segmentation register (USBD_BUFSEGx).

There are 12 endpoints in this controller. Each of the endpoint can be configured as IN or OUT endpoint. All the operations including Control, Bulk, Interrupt and Isochronous transfer are implemented in this block. The block of "Endpoint Control" is also used to manage the data sequential synchronization, endpoint states, current start address, transaction status, and data buffer status for each endpoint.

There are four different interrupt events in this controller. They are the no-event-wake-up, device plug-in or plug-out event, USB events, like IN ACK, OUT ACK etc, and BUS events, like suspend and resume, etc. Any event will cause an interrupt, and users just need to check the related event flags in interrupt event status register (USBD_INTSTS) to acknowledge what kind of interrupt occurring, and then check the related USB Endpoint Status Register (USBD_EPSTS0 and USBD_EPSTS1) to acknowledge what kind of event occurring in this endpoint.

A software-disconnect function is also supported for this USB controller. It is used to simulate the disconnection of this device from the host. If user enables SE0 bit (USBD_SE0), the USB controller will force the output of USB_D+ and USB_D- to level low and its function is disabled. After disable the SE0 bit, host will enumerate the USB device again.

For more information on the Universal Serial Bus, please refer to *Universal Serial Bus Specification Revision 1.1*.

6.30.2 Features

- Compliant with USB 2.0 Full-Speed specification
- Provides 1 interrupt vector with 4 different interrupt events (NEVWK, VBUSDET, USB and BUS)
- Supports Control/Bulk/Interrupt/Isochronous transfer type
- Supports suspend function when no bus activity existing for 3 ms
- Supports 12 endpoints for configurable Control/Bulk/Interrupt/Isochronous transfer types and maximum 1 Kbyte buffer size
- Provides remote wake-up capability

6.31 High Speed USB 2.0 Device Controller (HSUSBD)

6.31.1 Overview

The USB device controller interfaces the AHB bus and the UTMI bus. The USB controller contains both the AHB master interface and AHB slave interface. CPU programs the USB controller registers through the AHB slave interface. For IN or OUT transfer, the USB device controller needs to write data to memory or read data from memory through the AHB master interface. The USB device controller is compliant with USB 2.0 specification and it contains 12 configurable endpoints in addition to control endpoint. These endpoints could be configured to BULK, INTERRUPT or ISO. The USB device controller has a built-in DMA to relieve the load of CPU.

6.31.2 Features

- USB Specification reversion 2.0 compliant
- Supports 12 configurable endpoints in addition to Control Endpoint
- Each of the endpoints can be Isochronous, Bulk or Interrupt and either IN or OUT direction
- Three different operation modes of an in-endpoint – Auto Validation mode, Manual Validation mode, Fly mode
- Supports DMA operation
- 4092 Bytes Configurable RAM used as endpoint buffer
- Supports Endpoint Maximum Packet Size up to 1024 bytes

6.32 USB 2.0 Host Controller (USBH)

6.32.1 Overview

This chip is equipped with a USB 2.0 HS/FS Host Controller (USBH) that supports Enhanced Host Controller Interface (EHCI) and Open Host Controller Interface (OpenHCI, OHCI) Specification, a register-level description of a host controller, to manage the devices and data transfer of Universal Serial Bus (USB).

The USBH supports an integrated Root Hub with a USB port, a DMA for real-time data transfer between system memory and USB bus, port power control and port over current detection.

The USBH is responsible for detecting the connect and disconnect of USB devices, managing data transfer, collecting status and activity of USB bus, providing power control and detecting over current of attached USB devices.

6.32.2 Features

- Compliant with Universal Serial Bus (USB) Specification Revision 2.0.
- Supports Enhanced Host Controller Interface (EHCI) Specification Revision 1.0
- Supports Open Host Controller Interface (OpenHCI) Specification Revision 1.0.
- Supports high-speed (480Mbps), full-speed (12Mbps) and low-speed (1.5Mbps) USB devices.
- Supports Control, Bulk, Interrupt, Isochronous and Split transfers.
- Supports an integrated Root Hub.
- Supports a port routing logic to route full/low speed device to OHCI controller.
- Supports two USB host port shared with USB device (OTG function).
- Supports port power control and port over current detection.
- Supports DMA for real-time data transfer.

6.33 USB On-The-Go (OTG)

6.33.1 Overview

The OTG controller interfaces to USB PHY and USB controllers which consist of a USB 1.1 host controller and a USB 2.0 FS device controller. The OTG controller supports HNP and SRP protocols defined in the “On-The-Go and Embedded Host Supplement to the USB 2.0 Revision 2.0 Specification”.

USB frame, including USB host, USB device, and OTG controller, can be configured as Host-only, Device-only, ID-dependent or OTG Device mode defined in USBROLE (SYS_USBPHY[1:0]). In Host-only mode, USB frame acts as USB host. USB frame can support both full-speed and low-speed transfer. In Device-only mode, USB frame acts as USB device. USB frame only supports full-speed transfer. In ID-dependent mode, USB frame can be USB Host or USB device depending on USB_ID pin state. In OTG device mode, the role of USB frame depends on the definition of OTG specification. USB frame only supports full-speed transfer when OTG device acts as a peripheral.

6.33.2 Features

- Built-in USB PHY
- Configurable to operate as:
 - Host-only
 - Device-only
 - ID-dependent: The role of USB frame is only dependent on USB_ID pin value--as USB Host (USB_ID pin is low) or USB Device (USB_ID pin is high). Not support HNP or SRP protocol.
 - OTG device: dependent on USB_ID pin status to be A-device (USB_ID pin is low) or B-device (USB_ID pin is high). Support HNP and SRP protocols.

6.34 High Speed USB On-The-Go (HSOTG)

6.34.1 Overview

The HSOTG controller interfaces to USB PHY and USB controllers which consist of a USB 2.0 host controller and a USB 2.0 HS device controller. The OTG controller supports HNP and SRP protocols defined in the “On-The-Go and Embedded Host Supplement to the USB 2.0 Revision 1.3 Specification”.

USB frame, including USB host, USB device, and OTG controller, can be configured as Host-only, Device-only, ID-dependent or OTG Device mode defined in HSUSBROLE (SYS_USBPHY[17:16]). In Host-only mode, USB frame acts as USB host. USB frame can support high-speed, full-speed and low-speed transfer. In Device-only mode, USB frame acts as USB device. USB frame supports high-speed and full-speed transfer. In ID-dependent mode, USB frame can be USB Host or USB device depends on USB_ID pin state. In OTG device mode, the role of USB frame depends on the definition of OTG specification. USB frame supports high-speed and full-speed transfer when OTG device acts as a peripheral.

6.34.2 Features

- Built in USB PHY
- Configurable to operate as:
 - Host-only
 - Device-only
 - ID-dependent: The role of USB frame is only dependent on USB_ID pin value--as USB Host (USB_ID pin is low) or USB Device (USB_ID pin is high). Not support HNP or SRP protocol.
 - OTG device: dependent on USB_ID pin status to be A-device (USB_ID pin is low) or B-device (USB_ID pin is high). Support HNP and SRP protocols.

6.34.3 Basic Configuration

The OTG peripheral clock can be enabled by HSOTGCKEN (CLK_APBCLK0[30]). The role of USB frame is determined by HSUSBROLE (SYS_USBPHY[17:16]). These two configurations are write-protection bits. Before writing to these bits, user must disable the register protection function. Refer to the description of SYS_REGLCTL register for details. USB_VBUS_EN and USB_VBUS_ST pin functions are configured in SYS_GPA_MFPL or SYS_GPC_MFPL registers.

6.35 CRC Controller (CRC)

6.35.1 Overview

The Cyclic Redundancy Check (CRC) generator can perform CRC calculation with four common polynomials CRC-CCITT, CRC-8, CRC-16, and CRC-32 settings.

6.35.2 Features

- Supports four common polynomials CRC-CCITT, CRC-8, CRC-16, and CRC-32
 - CRC-CCITT: $X^{16} + X^{12} + X^5 + 1$
 - CRC-8: $X^8 + X^2 + X + 1$
 - CRC-16: $X^{16} + X^{15} + X^2 + 1$
 - CRC-32: $X^{32} + X^{26} + X^{23} + X^{22} + X^{16} + X^{12} + X^{11} + X^{10} + X^8 + X^7 + X^5 + X^4 + X^2 + X + 1$
- Programmable seed value
- Supports programmable order reverse setting for input data and CRC checksum
- Supports programmable 1's complement setting for input data and CRC checksum
- Supports 8/16/32-bit of data width
 - 8-bit write mode: 1-AHB clock cycle operation
 - 16-bit write mode: 2-AHB clock cycle operation
 - 32-bit write mode: 4-AHB clock cycle operation
- Supports using PDMA to write data to perform CRC operation

6.36 Cryptographic Accelerator (CRYPTO)

6.36.1 Overview

The Crypto (Cryptographic Accelerator) includes a secure pseudo random number generator (PRNG) core and supports AES, DES/TDES, SHA and HMAC algorithms.

The PRNG core supports 64 bits, 128 bits, 192 bits, and 256 bits random number generation.

The AES accelerator is an implementation fully compliant with the AES (Advance Encryption Standard) encryption and decryption algorithm. The AES accelerator supports ECB, CBC, CFB, OFB, CTR, CBC-CS1, CBC-CS2, and CBC-CS3 mode.

The DES/TDES accelerator is an implementation fully compliant with the DES and Triple DES encryption/decryption algorithm. The DES/TDES accelerator supports ECB, CBC, CFB, OFB, and CTR mode.

The SHA accelerator is an implementation fully compliant with the SHA-160, SHA-224, SHA-256, SHA-384, and SHA-512 and corresponding HMAC algorithms.

The ECC accelerator is an implementation fully compliant with elliptic curve cryptography by using polynomial basis in binary field and prime field.

6.36.2 Features

- PRNG
 - Supports 64 bits, 128 bits, 192 bits, and 256 bits random number generation
- AES
 - Supports FIPS NIST 197
 - Supports SP800-38A and addendum
 - Supports 128, 192, and 256 bits key
 - Supports both encryption and decryption
 - Supports ECB, CBC, CFB, OFB, CTR, CBC-CS1, CBC-CS2, and CBC-CS3 mode
 - Supports key expander
- DES
 - Supports FIPS 46-3
 - Supports both encryption and decryption
 - Supports ECB, CBC, CFB, OFB, and CTR mode
- TDES
 - Supports FIPS NIST 800-67
 - Implemented according to the X9.52 standard
 - Supports two keys or three keys mode
 - Supports both encryption and decryption
 - Supports ECB, CBC, CFB, OFB, and CTR mode
- SHA
 - Supports FIPS NIST 180, 180-2
 - Supports SHA-160, SHA-224, SHA-256, SHA-384, and SHA-512
- HMAC

- Supports FIPS NIST 180, 180-2
- Supports HMAC-SHA-160, HMAC-SHA-224, HMAC-SHA-256, HMAC-SHA-384, and HMAC-SHA-512
- ECC
 - Supports both prime field GF(p) and binary field GF(2^m)
 - Supports NIST P-192, P-224, P-256, P-384, and P-521
 - Supports NIST B-163, B-233, B-283, B-409, and B-571
 - Supports NIST K-163, K-233, K-283, K-409, and K-571
 - Supports point multiplication, addition and doubling operations in GF(p) and GF(2^m)
 - Supports modulus division, multiplication, addition and subtraction operations in GF(p)

6.37 Enhanced 12-bit Analog-to-Digital Converter (EADC)

6.37.1 Overview

The chip contains one 12-bit successive approximation analog-to-digital converter (SAR ADC converter) with 16 external input channels and 3 internal channels. The ADC converter can be started by software trigger, EPWM0/1 triggers, BPWM0/1 triggers, timer0~3 overflow pulse triggers, ADINT0, ADINT1 interrupt EOC (End of conversion) pulse trigger and external pin (EADC0_ST) input signal.

6.37.2 Features

- Analog input voltage range: 0~ VREF (Max to 3.6V)
- Reference voltage from VREF pin or AV_{DD}
- 12-bit resolution and 10-bit accuracy is guaranteed
- Up to 16 single-end analog external input channels or 8 pair differential analog input channels
- Up to 3 internal channels, they are band-gap voltage (VBG), temperature sensor (VTEMP), and V_{DD} power.
- Four ADC interrupts (ADINT0~3) with individual interrupt vector addresses
- Maximum ADC clock frequency is 72 MHz
- Up to 5.14 MSPS conversion rate
- Configurable ADC internal sampling time.
- 12-bit, 10-bit, 8-bit, 6-bit configurable resolution.
- Supports calibration and load calibration words capability.
- Supports internal reference voltage VREF: 1.6V, 2.0V, 2.5V, and 3.0V.
- Supports three power saving modes:
 - Deep Power-down mode
 - Power-down mode
 - Standby mode
- Up to 19 sample modules
 - Each of sample modules which is configurable for ADC converter channel EADC_CH0~15 and trigger source
 - Sample module 16~18 is fixed for ADC channel 16, 17, 18 input sources as band-gap voltage, temperature sensor, and V_{DD} power.
 - Double buffer for sample control logic module 0~3
 - Configurable sampling time for each sample module
 - Conversion results are held in 19 data registers with valid and overrun indicators
- An ADC conversion can be started by:
 - Write 1 to SWTRGn (EADC_SWTRG[n], n = 0~18)
 - External pin EADC0_ST
 - Timer0~3 overflow pulse triggers
 - ADINT0 and ADINT1 interrupt EOC (End of conversion) pulse triggers
 - EPWM/BPWM triggers

- Supports PDMA transfer
- Conversion Result Monitor by Compare Mode

6.38 Digital to Analog Converter (DAC)

6.38.1 Overview

The DAC module is a 12-bit, voltage output digital-to-analog converter. It can be configured to 12- or 8-bit output mode and can be used in conjunction with the PDMA controller. The DAC integrates a voltage output buffer that can be used to reduce output impedance and drive external loads directly without having to add an external operational amplifier.

6.38.2 Features

- Analog output voltage range: 0~AV_{DD}.
- Supports 12- or 8-bit output mode.
- Rail to rail settle time 8us.
- Supports up to two 12-bit 1 MSPS voltage type DAC.
- Reference voltage from internal reference voltage (INT_VREF), VREF pin or AV_{DD}.
- DAC maximum conversion updating rate 1 MSPS.
- Supports voltage output buffer mode and bypass voltage output buffer mode.
- Supports software and hardware trigger, including Timer0~3, EPWM0, EPWM1, and external trigger pin to start DAC conversion.
- Supports PDMA mode.
- Supports group mode of synchronized update capability for two DACs.

6.39 Analog Comparator Controller (ACMP)

6.39.1 Overview

The chip provides two comparators. The comparator output is logic 1 when positive input is greater than negative input; otherwise, the output is 0. Each comparator can be configured to generate an interrupt when the comparator output value changes.

6.39.2 Features

- Analog input voltage range: 0 ~ VDDA (voltage of AV_{DD} pin)
- Up to two rail-to-rail analog comparators
- Supports hysteresis function
 - Supports programmable hysteresis window: 0mV, 10mV, 20mV and 30mV
- Supports wake-up function
- Supports programmable propagation speed and low power consumption
- Selectable input sources of positive input and negative input
- ACMP0 supports:
 - 4 multiplexed I/O pins at positive sources:
 - ◆ ACMP0_P0, ACMP0_P1, ACMP0_P2, or ACMP0_P3
 - 4 negative sources:
 - ◆ ACMP0_N
 - ◆ Comparator Reference Voltage (CRV)
 - ◆ Internal band-gap voltage (VBG)
 - ◆ DAC0 output (DAC0_OUT)
- ACMP1 supports
 - 4 multiplexed I/O pins at positive sources:
 - ◆ ACMP1_P0, ACMP1_P1, ACMP1_P2, or ACMP1_P3
 - 4 negative sources:
 - ◆ ACMP1_N
 - ◆ Comparator Reference Voltage (CRV)
 - ◆ Internal band-gap voltage (VBG)
 - ◆ DAC0 output (DAC0_OUT)
- Shares one ACMP interrupt vector for all comparators
- Interrupts generated when compare results change (Interrupt event condition is programmable)
- Supports triggers for break events and cycle-by-cycle control for EPWM
- Supports window compare mode and window latch mode

6.40 OP Amplifier (OPA)

6.40.1 Overview

This device is equipped with three operational amplifiers. Users can enable each of them individually, by their application purpose. One of these OP amplifier outputs is connected to ADC channel for measurement requirement. The OP amplifier circuit also can be used in the application of Programmable Gain Amplifier (PGA).

6.40.2 Features

- Analog input voltage range: 0~VDD.
- Supports up to 3 operator amplifiers.
- Supports to use Schmitt trigger buffer output for simple comparator function.
- Supports to Schmitt trigger buffer output interrupts.

7 APPLICATION CIRCUIT

7.1 Power Supply Scheme with External Vref

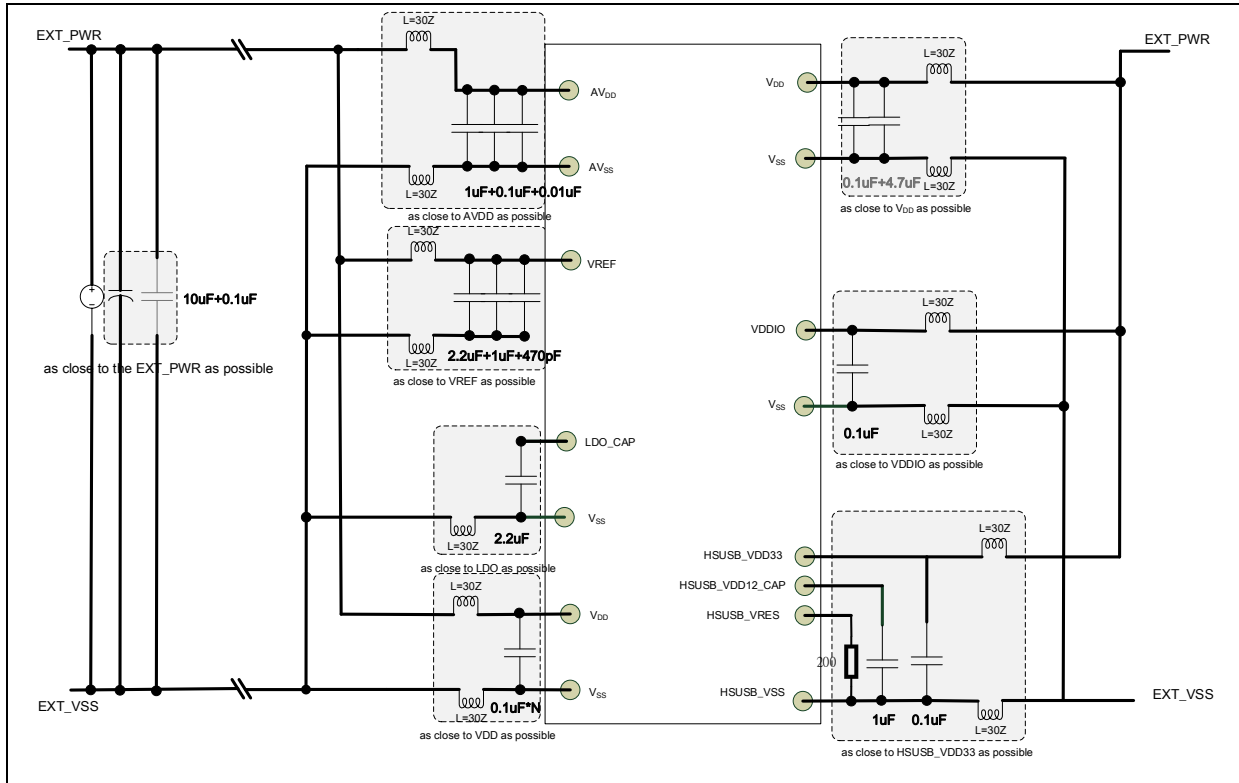

Note: Total capacitance of LDO_CAP pin is 2.2uF.

7.2 Power Supply Scheme with Internal Vref

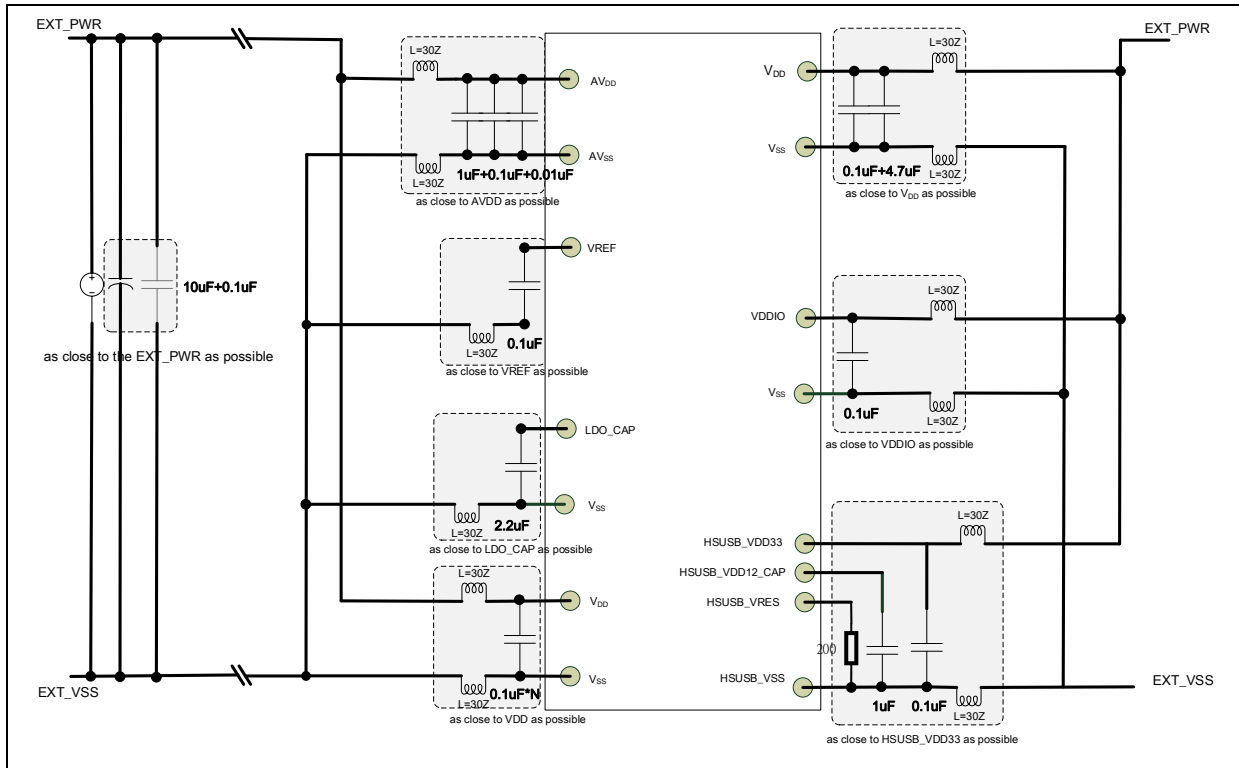

Note: Total capacitance of LDO_CAP pin is 2.2uF.

7.3 Power Supply Scheme with V_{REF} and External RTC with Battery Power

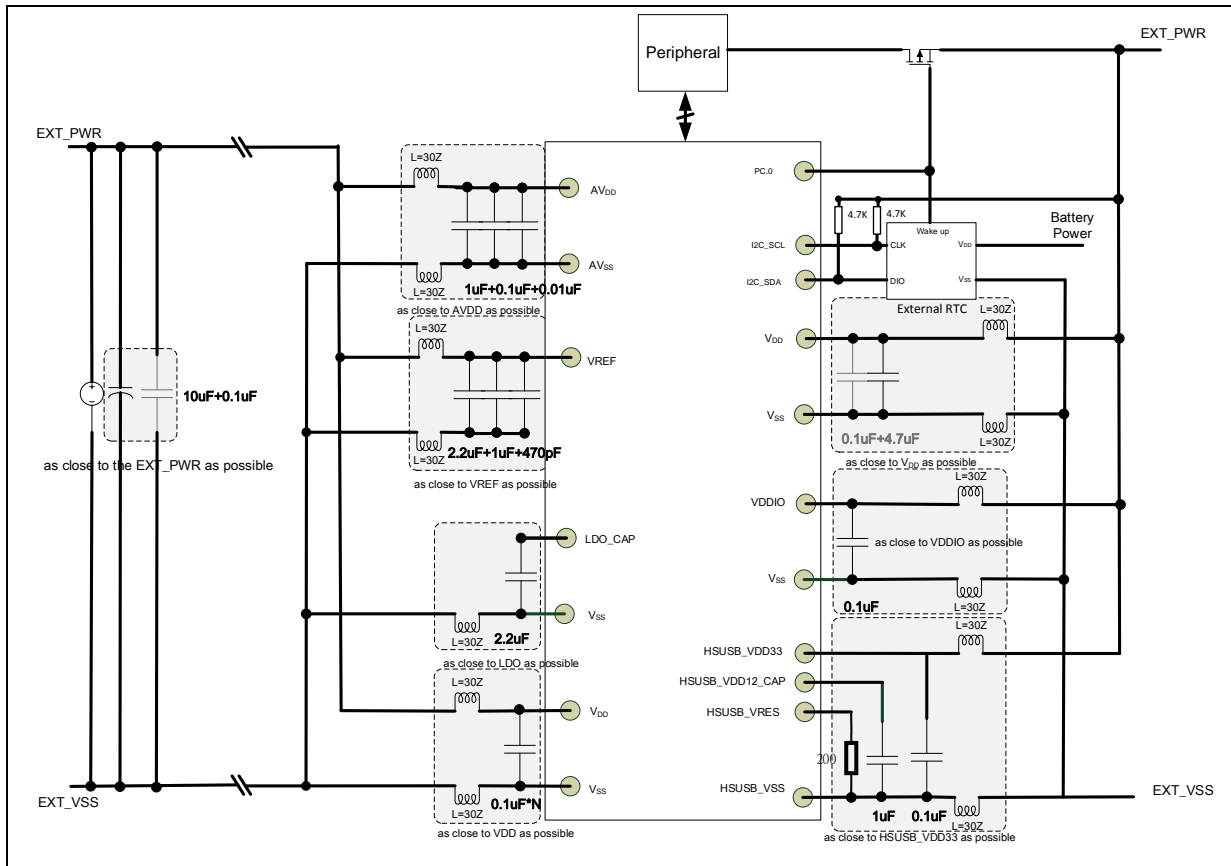

Note: Total capacitance of LDO_CAP pin is 2.2µF.

7.4 Power Supply Scheme with V_{REF} and Internal RTC with Battery Power

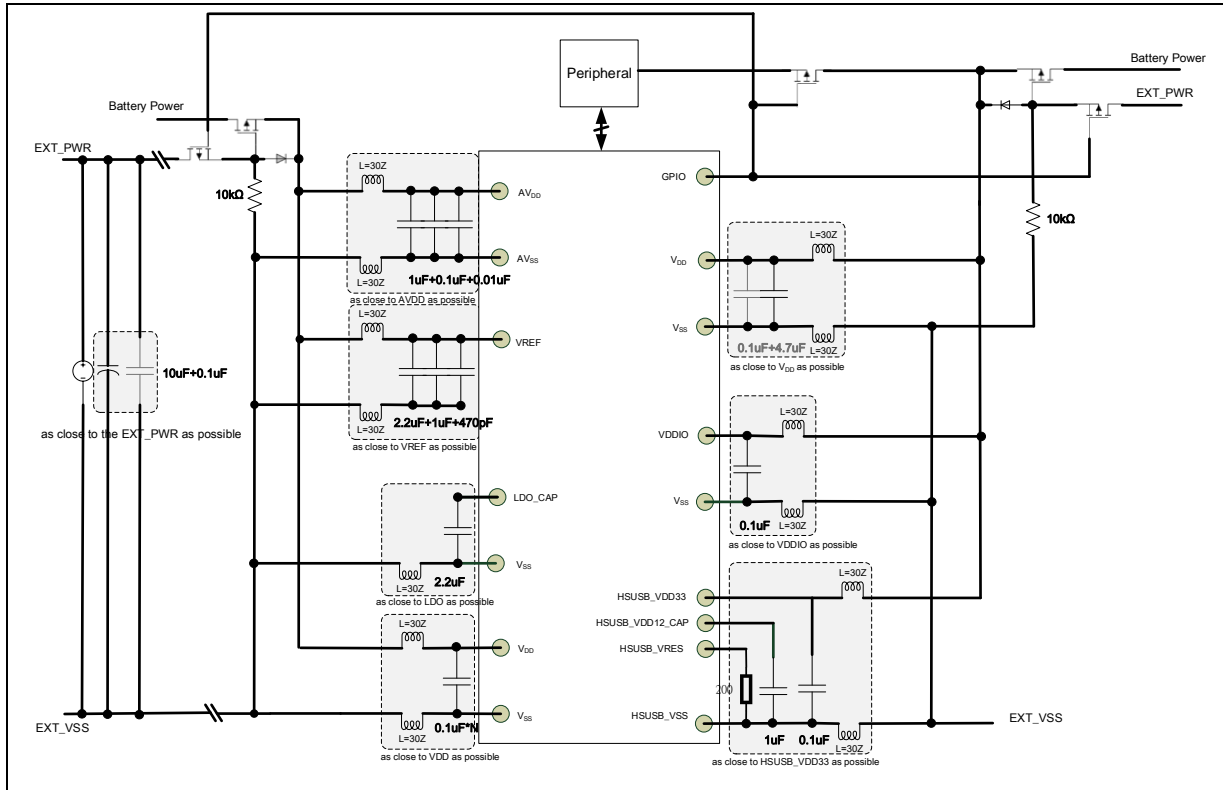

Note: Total capacitance of LDO_CAP pin is 2.2uF.

7.5 Peripheral Application Scheme

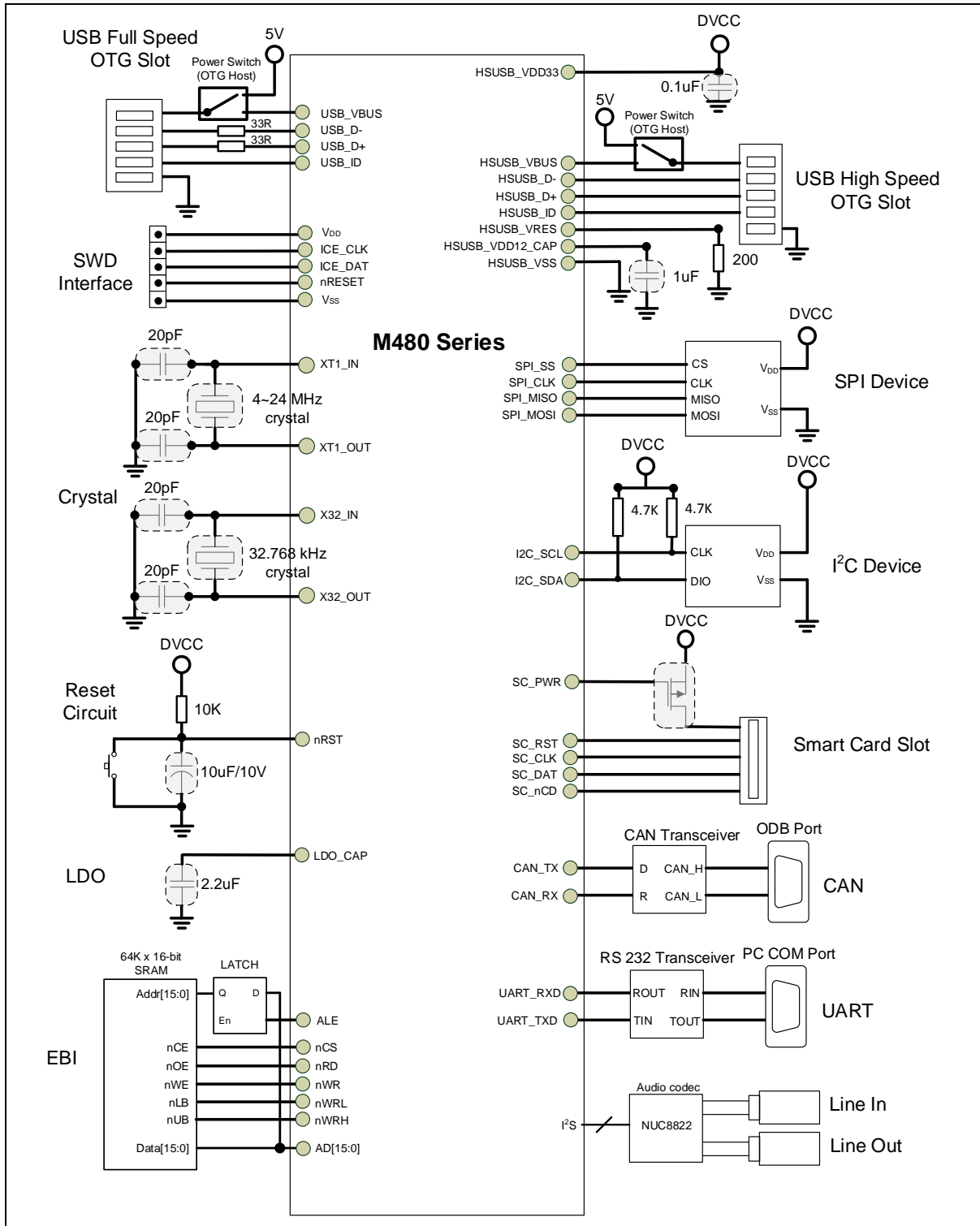

Note:

1. USB_ID, HSUSB_ID could be floating using USB or USB HS without OTG.
2. Total capacitance of LDO_CAP pin is 2.2uF.

8 ELECTRICAL CHARACTERISTICS

8.1 Absolute Maximum Ratings

8.1.1 Voltage Characteristics

PARAMETER	SYMBOL	MIN	MAX	UNIT
$V_{DD}-V_{SS}[*1]$	DC Power Supply	-0.3	4	V
$V_{DDIO}-V_{SS}$	V_{DDIO} Power Supply	-0.3	4	V
$ V_{DDX} - V_{DD} $	Variations between different power pins		50	mV
$ V_{DD} - AV_{DD} $	Allowed voltage difference for V_{DD} and AV_{DD}		50	mV
$ V_{SSX} - V_{SS} $	Variations between different ground pins		50	mV
$ V_{SS} - AV_{SS} $	Allowed voltage difference for V_{SS} and AV_{SS}		50	mV
V_{IN}	Input Voltage on 5V-tolerance GPIO		5.5	V
	Input Voltage on RTC domain (PF.6 ~ PF.11)		V_{DD}	V
	Input Voltage on any other pin[*2]		V_{DD}	V

Table 8.1-1 Voltage Characteristics

Note:

- All main power (V_{DD} , AV_{DD}) and ground (V_{SS} , AV_{SS}) pins must always be connected to the external power supply, in the permitted range.
- Non 5V-tolerance PIN: PA.8 ~ 15; PB.0 ~ 15; PD.10, 11, 12; PF.2, 3, 4, 5; All USB High Speed PIN and nRESET PIN.

8.1.2 Current Characteristics

SYMBOL	PARAMETER	MIN	MAX	UNIT
I_{DD}	Maximum Current into V_{DD}		200	mA
I_{DDIO}	Maximum Current into V_{DDIO}		100	
I_{SS}	Maximum Current out of V_{SS}		100	
I_{IO}	Maximum Current sunk by a I/O Pin		20	
	Maximum Current Sourced by a I/O Pin		20	
	Maximum Current Sunk by Total I/O Pins		100	
	Maximum Current Sourced by Total I/O Pins		100	

Table 8.1-2 Current Characteristics

8.1.3 Thermal Characteristics

SYMBOL	PARAMETER	MIN	MAX	UNIT
T_A	Operating Temperature	-40	105	°C
T_J	Junction temperature	-40	125	
T_{ST}	Storage Temperature	-65	150	

Table 8.1-3 Thermal Characteristics

8.1.4 EMC Characteristics

Symbol	Parameter	Conditions	Maximum value	Unit
V _{EFTB}	<ol style="list-style-type: none"> Fast transient voltage burst limits to be applied through 100 pF + 47uF on V_{DD} and V_{SS} pins to induce a functional disturbance to be applied through 2.2uF on LDO_Pin and V_{SS} pins 	V _{DD} = 3.3 V, LQFP144, T _A = +25 °C, f _{HCLK} = 160 MHz	4.4	kV

Table 8.1-4 EMS Characteristics

Symbol	Parameter	Conditions	Value	Unit
LU	Static latch-up class	T _A = +25 °C	400mA	mA

Table 8.1-5 Electrical Characteristics

Note: Guaranteed by characterization results, not tested in production.

8.2 General Operating Conditions

(V_{DD}-V_{SS} = 1.8 ~ 3.6V, T_A = 25°C, HCLK = 192 MHz unless otherwise specified.)

SYMBOL	PARAMETER	Conditions	MIN	TYP	MAX	UNIT
f _{HCLK}	Internal AHB clock frequency				192	MHz
V _{DD}	Operation Voltage		1.8		3.6	V
AV _{DD}	Analog Operation Voltage		V _{DD}			
V _{DDIO}	Power supply for PA.0 ~ 5		1.8		3.6	
V _{LDO}	LDO Output Voltage		1.08	1.2	1.32	
V _{BG}	Band-gap Voltage	V _{DD} = 1.8 V ~ 3.6 V	1.18		1.21	
C _{LDO}	LDO Output capacitance on each pin			2.2		uF
t _{VDD}	V _{DD} rise time rate		10	-		μs/V
	V _{DD} fall time rate	BOD Disabled, LVR Enabled[*1]	400	-		
		BOD Disabled, LVR Enabled[*2]	500			
		BOD 1.6V Enabled	80			
	BOD 3.0V Enabled	80				

Note:

1. LVR in active mode
2. LVR in low power mode

8.3 DC Electrical Characteristics

8.3.1 Typical Current Consumption

- ALL GPIO pins are in push pull mode, output high.
- LDO = 1.26V
- The maximum values are obtained for $V_{DD} = 3.6\text{ V}$ and maximum ambient temperature (T_A), and the typical values for $T_A = 25\text{ °C}$ and $V_{DD} = 3.3\text{ V}$ unless otherwise specified.
- $V_{DD} = AV_{DD} = V_{DDIO}$
- When the peripherals are enabled HCLK is the system clock, $f_{PCLK0,1} = f_{HCLK}/2$.
- Program run while(1){} from flash.

Symbol	Conditions	fHCLK	HXT/LXT	HIRC/LIRC	PLL	Typ	Unit
						T _A = 25 °C	
I _{DD}	Normal Run, executed from flash, V _{DD} = 3.3V, all peripherals disable	192 MHz	12MHz	-	V	34.00	mA
		160 MHz	12MHz	-	V	28.76	
		144 MHz	12MHz	-	V	26.00	
		120 MHz	12MHz	-	V	22.21	
		12 MHz	12MHz	-	-	3.49	
		192 MHz	-	12MHz	V	33.29	
		160 MHz	-	12MHz	V	28.11	
		144 MHz	-	12MHz	V	25.51	
		120 MHz	-	12MHz	V	21.59	
		12 MHz	-	12MHz	-	2.98	
	32.768 KHz	32.768 kHz	-	-	0.57		
	10 KHz	-	10KHz	-	0.57		
	Normal run, External clock, executed from flash, V _{DD} = 3.3V, all peripherals enabled	192 MHz	-	12MHz	V	70.05	
		160 MHz	-	12MHz	V	58.99	
		144 MHz	-	12MHz	V	53.43	
		120 MHz	-	12MHz	V	45.04	
		12 MHz	-	12MHz	-	5.60	
		192 MHz	12MHz	-	V	70.70	
		160 MHz	12MHz	-	V	60.41	
		144 MHz	12MHz	-	V	53.75	
120 MHz		12MHz	-	V	46.04		
12 MHz		12MHz	-	-	5.85		
32.768 KHz	32.768 kHz	-	-	0.58			
10 KHz	-	10KHz	-	0.57			

Table 8.3-1 Current Consumption in Normal Run Mode

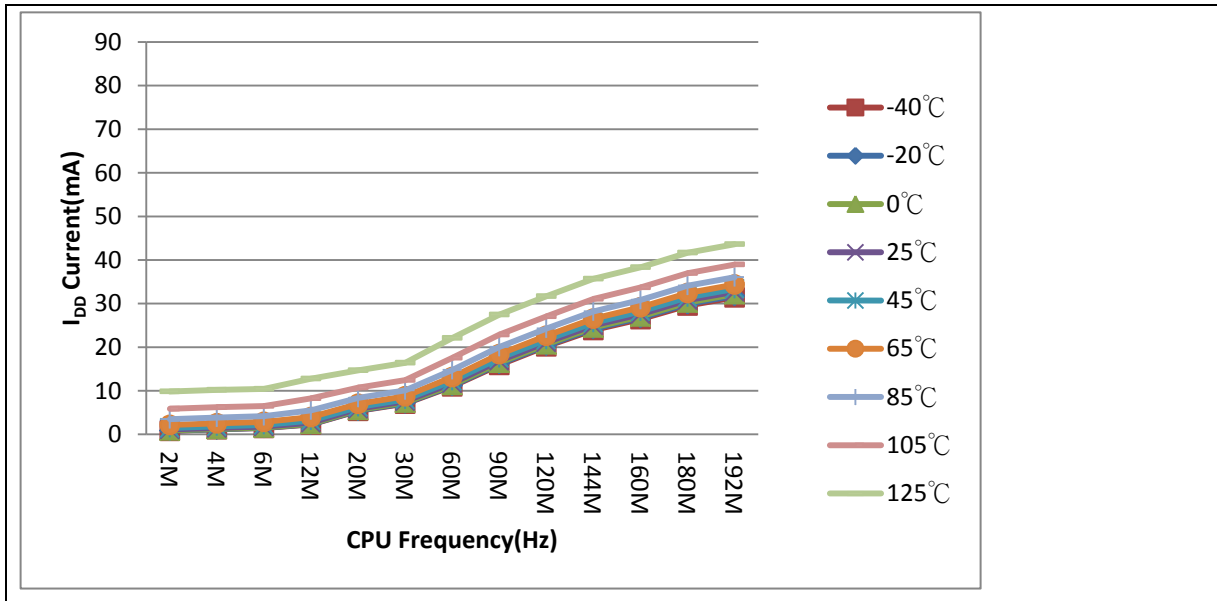

Figure 8.3-1 Current Consumption versus Temperature in Normal Run Mode, $V_{DD} = 3.3V$, All Peripherals Disabled, PLL Source from HIRC

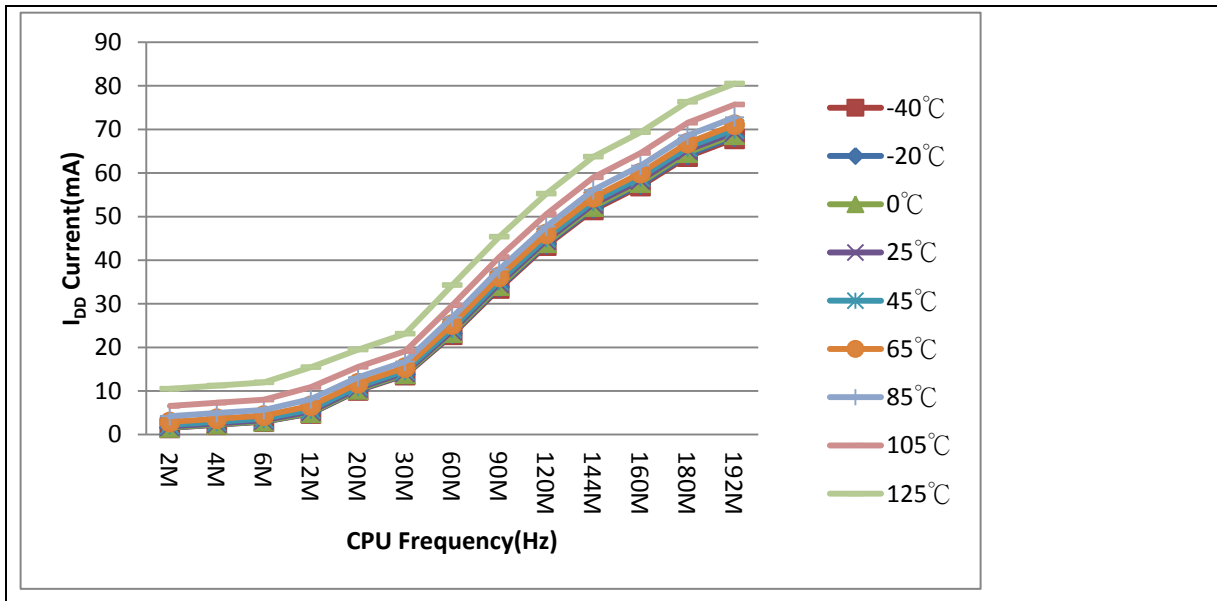

Figure 8.3-2 Current Consumption versus Temperature in Normal Run Mode, $V_{DD} = 3.3V$, All Peripherals Enabled, PLL Source from HIRC

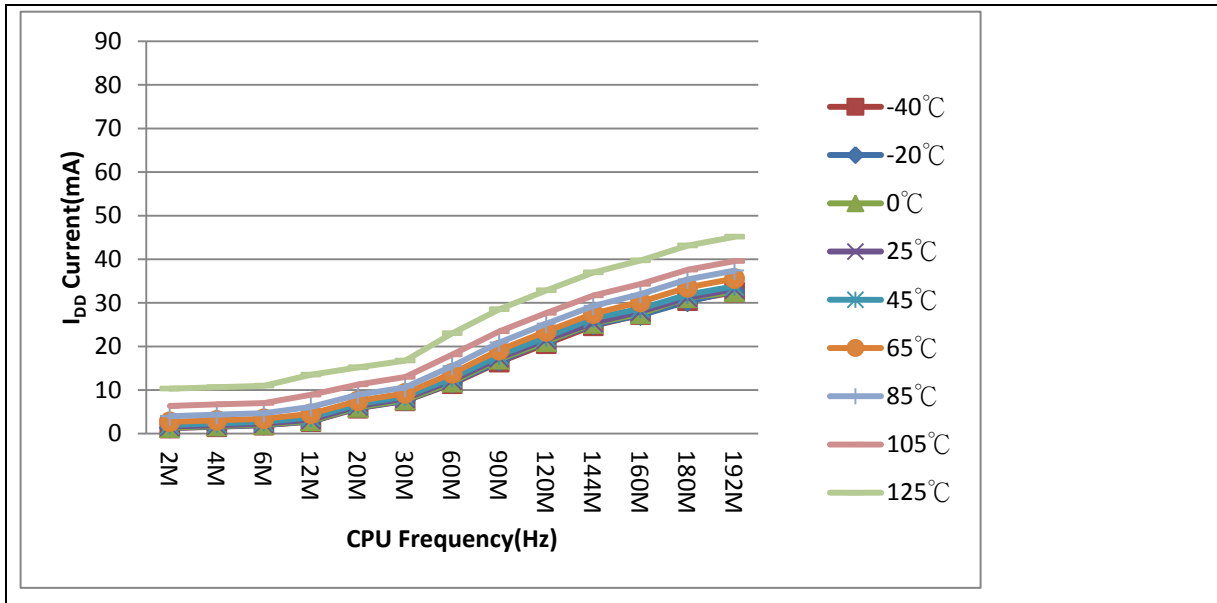

Figure 8.3-3 Current Consumption versus temperature in Normal Run Mode, $V_{DD} = 3.3V$, All Peripherals Disabled, PLL Source from HXT

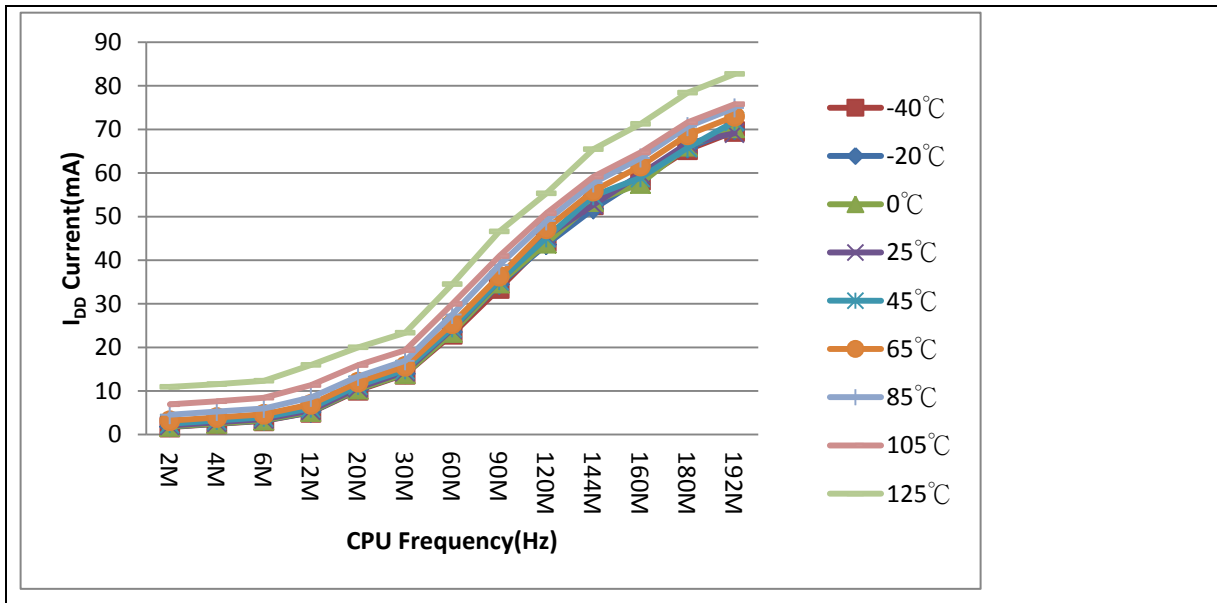

Figure 8.3-4 Current Consumption versus Temperature in Normal Run Mode, $V_{DD} = 3.3V$, All Peripherals Enabled, PLL Source from HXT

Symbol	Conditions	f _{HCLK}	HXT/LXT	HIRC/LIRC	PLL	Typ	Unit
						T _A = 25 °C	

I _{DD}	Idle mode, executed from flash, V _{DD} = 3.3V, all peripherals disable	192 MHz	12MHz	-	V	10.32	mA
		160 MHz	12MHz	-	V	8.95	
		144 MHz	12MHz	-	V	8.23	
		120 MHz	12MHz	-	V	7.23	
		12 MHz	12MHz	-	-	1.98	
		192 MHz	-	12MHz	V	9.76	
		160 MHz	-	12MHz	V	8.40	
		144 MHz	-	12MHz	V	7.72	
		120 MHz	-	12MHz	V	6.70	
		12 MHz	-	12MHz	-	1.47	
		32.768 KHz	32.768 kHz	-	-	0.57	
	10 KHz	-	10KHz	-	0.57		
	Idle mode, External clock, executed from flash, V _{DD} = 3.3V, all peripherals enabled	192 MHz	-	12MHz	V	49.64	
		160 MHz	-	12MHz	V	41.82	
		144 MHz	-	12MHz	V	37.89	
		120 MHz	-	12MHz	V	31.96	
		12 MHz	-	12MHz	-	4.03	
		192 MHz	12MHz	-	V	50.36	
		160 MHz	12MHz	-	V	42.75	
		144 MHz	12MHz	-	V	38.29	
		120 MHz	12MHz	-	V	32.70	
		12 MHz	12MHz	-	-	4.52	
32.768 KHz		32.768 kHz	-	-	0.58		
10 KHz	-	10KHz	-	0.57			

Table 8.3-2 Current Consumption in Idle Mode

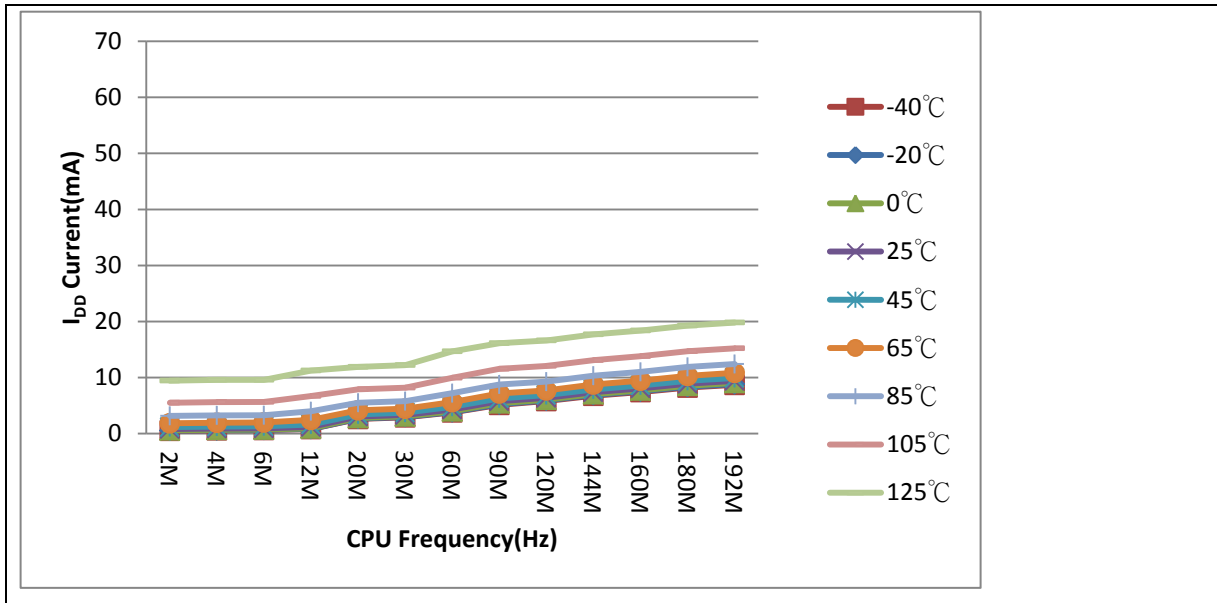

Figure 8.3-5 Current Consumption versus Temperature in Idle Mode, $V_{DD} = 3.3V$, All Peripherals Disabled, PLL Source from HIRC

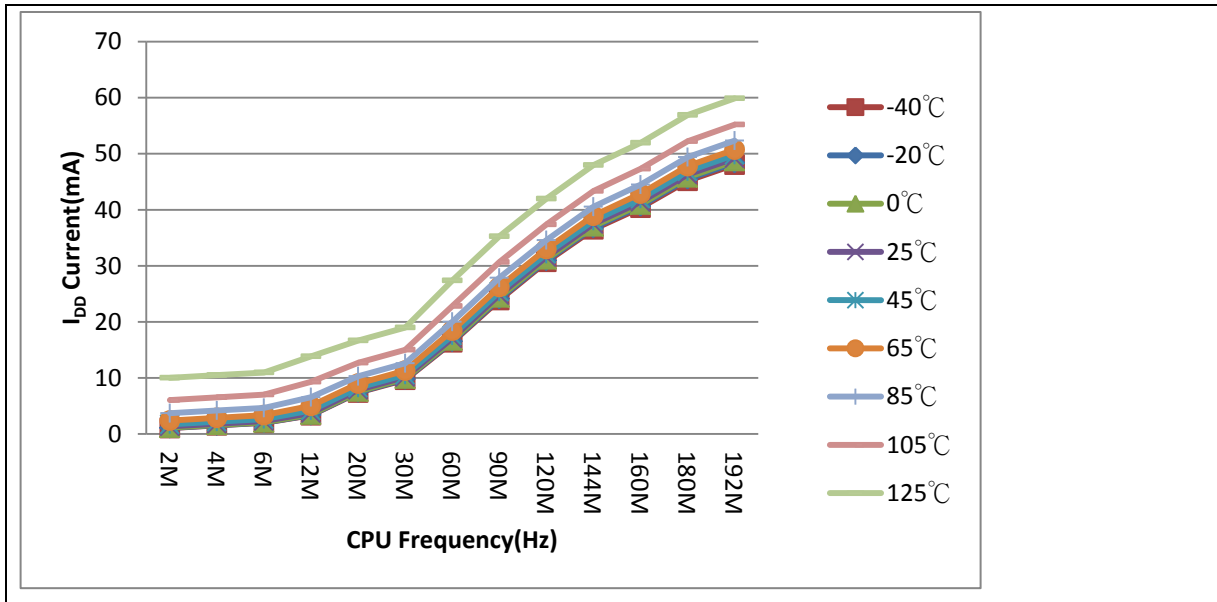

Figure 8.3-6 Current Consumption versus Temperature in Idle Mode, $V_{DD} = 3.3V$, All Peripherals Enabled, PLL Source from HIRC

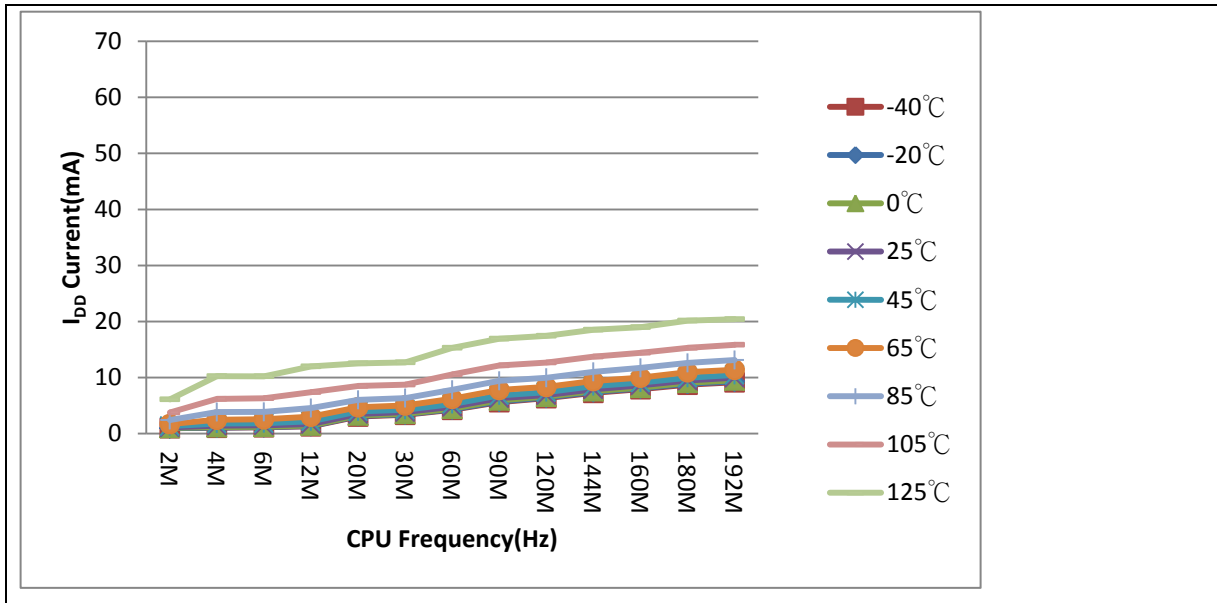

Figure 8.3-7 Current Consumption versus Temperature in Idle Mode, V_{DD} = 3.3V , All Peripherals Disabled, PLL Source from HXT

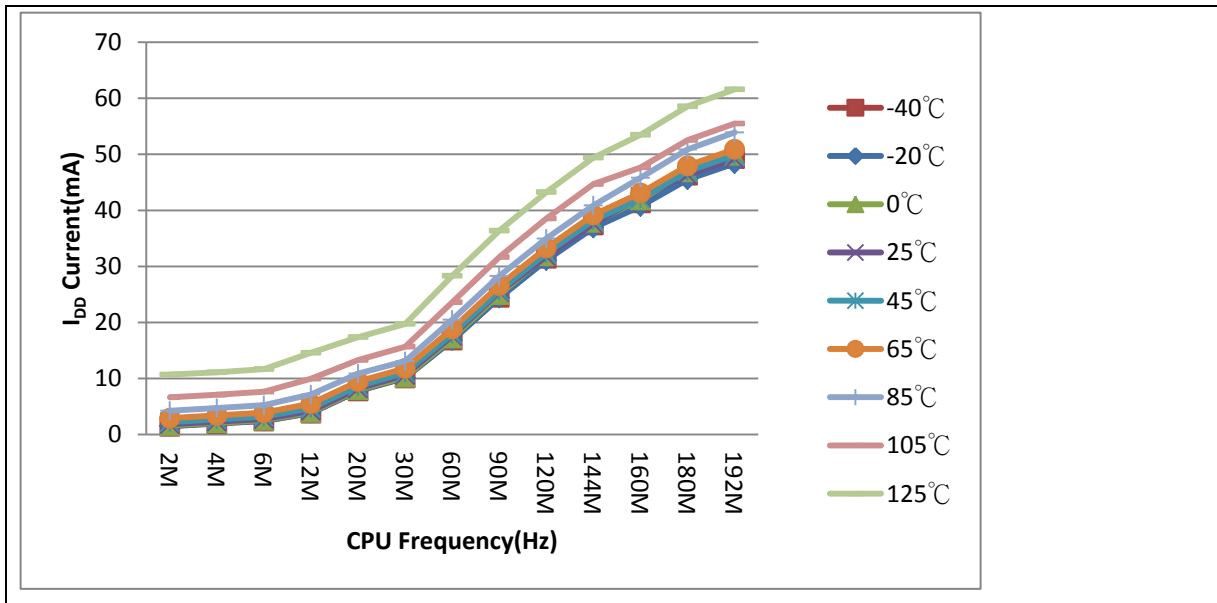

Figure 8.3-8 Current Consumption versus Temperature in Idle Mode, V_{DD} = 3.3V , All Peripherals Enabled, PLL Source from HXT

Symbol	Conditions	LXT	LIRC	PLL	Typ	Unit
					T _A = 25 °C	

I _{DD_FWPD}	Fast wake-up Power-down mode, V _{DD} = 3.3V, all peripherals disabled	-	-	-	0.49	mA
	Fast wake-up Power-down mode, V _{DD} = 3.3V, RTC/WDT/Timer/UART enable	V	-	-	0.49	
	Fast wake-up Power-down mode, V _{DD} = 3.3V, RTC/WDT/Timer enable	-	V	-	0.49	
	Fast wake-up Power-down mode, V _{DD} = 3.3V, WDT/Timer use LIRC, RTC/UART use LXT	V	V	-	0.49	
I _{DD_PD}	Power-down mode, V _{DD} = 3.3V, all peripherals disabled	-	-	-	0.37	mA
	Power-down mode, V _{DD} = 3.3V, RTC/WDT/Timer/UART enable	V	-	-	0.37	
	Power-down mode, V _{DD} = 3.3V, RTC/WDT/Timer use LIRCT	-	V	-	0.37	
	Power-down mode, V _{DD} = 3.3V, WDT/Timer use LIRC, RTC/UART use LX	V	V	-	0.37	
I _{DD_LLDPD}	Low leakage Power-down mode, V _{DD} = 3.3V, all peripherals disabled	-	-	-	0.14	mA
	Low leakage Power-down mode, V _{DD} = 3.3V, RTC/WDT/Timer/UART enable	V	-	-	0.37	
	Low leakage Power-down mode, V _{DD} = 3.3V, RTC/WDT/Timer enable	-	V	-	0.37	
	Low leakage Power-down mode, V _{DD} = 3.3V, WDT/Timer use LIRC, RTC/UART use LX	V	V	-	0.37	
I _{DD_SPD0}	Standby Power-down mode (SPD0), V _{DD} = 3.3V, all peripherals disabled	-	-	-	0.04	mA
	Standby Power-down mode (SPD0), V _{DD} = 3.3V, RTC enable	V	-	-	0.04	
	Standby Power-down mode (SPD0), V _{DD} = 3.3V, RTC enable	-	V	-	0.04	
I _{DD_SPD1}	Standby Power-down mode (SPD1), V _{DD} = 3.3V, all peripherals disabled	-	-	-	0.03	mA
	Standby Power-down mode (SPD1), V _{DD} = 3.3V, RTC enable	V	-	-	0.03	
	Standby Power-down mode (SPD1), V _{DD} = 3.3V, RTC enable	-	V	-	0.03	

I _{DD_DPD}	Deep Power-down mode(DPD), V _{DD} = 3.3V, all peripherals disabled	-	-	-	0.95	uA
---------------------	---	---	---	---	------	----

Table 8.3-3 Chip Current Consumption in Power-down Mode

Note: V_{DD} = AV_{DD} = V_{DDIO} = 3.3V

8.3.2 On-chip Peripheral Current Consumption

- ALL GPIO pins are in push pull mode, output high.
- LDO = 1.26V
- The typical values for T_A= 25 °C and V_{DD} = AV_{DD} = 3.3 V unless otherwise specified.
- When the peripherals are enabled HCLK is the system clock, f_{HCLK} = 192 MHz, f_{PCLK0, 1} = f_{HCLK}/2.

Peripheral	I _{DD}	Unit
DAC	58.4	uA
ADC	338.6	
ACMP01	85.2	
OPA	123.3	
QEIO	74.2	
QEI1	81.9	
ECAP0	74.3	
ECAP1	69.8	
EPWM0	907	
EPWM1	896.5	
BPWM0	263.8	
BPWM1	245.2	
WDT	49.6	
SD0	1416.1	
SD1	1263.6	
SC0	66.6	
SC1	76.6	
SC2	73.6	
I2S0	102.1	
SPIM	14681.1	
QSPI0	291.1	
SPI0	315.5	
SPI1	261.2	

SPI2	137.2
SPI3	138.7
UART0	150.6
UART1	209.1
UART2	220.0
UART3	160.5
UART4	186.5
UART5	177.5
I2C0	34.4
I2C1	26.6
I2C2	32.7
CAN0	280.5
CAN1	257.6
USCI0	211.9
USCI1	205.4
EBI	209.6
TMR0	140.5
TMR1	130.1
TMR2	127.1
TMR3	121.2
USB HS OTG	248.7
USB FS OTG	503.1
Crypto	1550.4
EMAC	1768.1

Note: Guaranteed by characterization results, not tested in production.

8.3.3 Wakeup Time

- The wakeup times given in Table 8.3-4 is measured on a wakeup phase with a 16 MHz HIRC oscillator. The clock source used to wake up the device depends from the current operating mode:
 - Fast-wakeup, power down, low leakage Power-down mode: the clock source is the RC oscillator
 - Standby and Deep Power-down mode: the clock source is the clock that was set before entering Sleep mode.
- The wakeup times are measured from the wakeup event to the point in which the application code reads the first instruction.
- The clock source is the RC oscillator from HIRC

Symbol	Parameter	Typ	Unit
t _{WU_IDLE}	Wakeup from IDLE mode	5 Cycles	μs
t _{WU_FWPD}	Wakeup from Fast-wakeup power down mode	6	
t _{WU_NPD}	Wakeup from normal power down mode	12	
t _{WU_LLPD}	Wakeup from low leakage power down mode	54	
t _{WU_SPD0}	Wakeup from Standby Power-down mode 0 (SPD0)	527	
t _{WU_SPD1}	Wakeup from Standby Power-down mode 1 (SPD1)	527	
t _{WU_DPD}	Deep Power-down mode (DPD)	489	

Table 8.3-4 Low-power Mode Wakeup Timings

8.3.4 PIN DC Characteristics

Symbol	Parameter	Min.	Typ.	Max.	unit	Test Conditions
V _{IL1}	Input Low Voltage (TTL input)			0.8	V	V _{DD} = V _{DDIO} = 3.6 V
				0.56	V	V _{DD} = V _{DDIO} = 1.8 V
V _{IH1}	Input High Voltage (TTL input)	2			V	V _{DD} = V _{DDIO} = 3.6V
		1.04			V	V _{DD} = V _{DDIO} = 1.8V
V _{IL2}	Input Low Voltage (Schmitt input)			0.3*V _{DD}	V	V _{DD} = V _{DDIO} = 3.6V
				0.3*V _{DD}		V _{DD} = V _{DDIO} = 1.8V
V _{IH2}	Input High Voltage (Schmitt input)	0.7*V _{DD}			V	V _{DD} = V _{DDIO} = 3.6V
		0.7*V _{DD}				V _{DD} = V _{DDIO} = 1.8V
V _{HY}	Hysteresis voltage of (Schmitt input)		0.2V _{DD}		V	
I _{LK}	Input Leakage Current	-1		1	μA	V _{DD} = V _{DDIO} = 3.6V, 0 < V _{IN} < V _{DD} , Open-drain or input only mode
R _{PU}	Input Pull Up Resistor		50		KΩ	V _{DD} = V _{DDIO} = 3.3V
			52		KΩ	V _{DD} = V _{DDIO} = 1.8V
R _{PD}	Input Pull down Resistor		50		KΩ	V _{DD} = V _{DDIO} = 3.3V
			52		KΩ	V _{DD} = V _{DDIO} = 1.8V

Table 8.3-5 PIN Input Characteristics

Symbol	Parameter	Min.	Typ.	Max.	unit	Test Conditions
I _{SR4}	Source Current (Push-pull Mode, Set GPIO to output HIGH, Apply GPIO pin VIN=(V _{DD} -0.4)V for V _{DD} and measure the source current)		-18		mA	V _{DD} = V _{DDIO} = 3.3V
I _{SR5}			-10		mA	V _{DD} = V _{DDIO} = 1.8V
I _{SR6}			-8		mA	V _{DD} = V _{DDIO} = 1.8V
I _{SK1}	Sink Current (Push-pull Mode, Set GPIO to output LOW, Apply GPIO pin VIN=(V _{SS} +0.4)V for V _{SS} and measure		17		mA	V _{DD} = V _{DDIO} = 3.3V
I _{SK2}			10		mA	V _{DD} = V _{DDIO} = 1.8V

I _{SK3}	the source current)		8		mA	V _{DD} = V _{DDIO} = 1.8V
C _{IO}	I/O pin capacitance		5		pF	

Table 8.3-6 PIN Output Characteristics

Symbol	Parameter	Min.	Typ.	Max.	unit	Test Conditions
V _{ILR}	Negative going threshold (Schmitt input), nRESET			0.3*V _{DD}	V	V _{DD} = 3.3V
V _{IHR}	Positive going threshold (Schmitt Input), nRESET	0.7*V _{DD}			V	V _{DD} = 3.3V
R _{RST}	Internal nRESET pin pull up resistor		50		KΩ	
t _{FR1}	nRESET input filtered time		32		uS	
t _{FR2}	nRESET input filtered time under SPD and DPD mode		300		nS	V _{DD} = 3.3V,

Table 8.3-7 nRESET PIN Characteristics

8.4 AC Electrical Characteristics

8.4.1 External 4~24 MHz High Speed Crystal (HXT) characteristics

- T_A = 25 °C and V_{DD} = 3.3 V unless otherwise specified.

SYM.	PARAMETER	SPECIFICATIONS				TEST CONDITION
		MIN.	TYP.	MAX.	UNIT	
V _{DD}	Operating Voltage	1.8		3.6	V	
R _f	Feedback resister		1000		kΩ	
f _{HXT}	Oscillator frequency	4		24	MHz	V _{DD} = 1.8 ~ 3.6V
T _{HXT}	Temperature Range	-40		105	°C	
I _{HXT_INV}	Current Consumption (INV-type Crystal)		650		μA	4MHz
			1600			12MHz
			2000			16MHz
			4000			24MHz
I _{HXT_GM}	Current Consumption (GM-type Crystal)		160		μA	4MHz
			280			12MHz
			400			16MHz
			600			24MHz
T _{S_GM}	Stable time (GM-type)	1545		1752	μs	4MHz, -40 °C
		1630		1757		4MHz, 25 °C
		1054		1988		4MHz, 105 °C
		484		512		12MHz, -40 °C
		484		544		12MHz, 25 °C
		386		606		12MHz, 105 °C
		349		375		16MHz, -40 °C
		337		399		16MHz, 25 °C
		281		444		16MHz, 105 °C
		259		303		24MHz, -40 °C
		248		330		24MHz, 25 °C
		210		403		24MHz, 105 °C
T _{S_INV}	Stable time (INV-type)	1490		23432	μs	4MHz, -40 °C
		1479		2352		4MHz, 25 °C
		1052		2105		4MHz, 105 °C
		464		558		12MHz, -40 °C

SYM.	PARAMETER	SPECIFICATIONS				TEST CONDITION
		MIN.	TYP.	MAX.	UNIT	
		481		554		12MHz, 25 °C
		417		663		12MHz, 105 °C
		317		420		16MHz, -40 °C
		326		407		16MHz, 25 °C
		290		472		16MHz, 105 °C
		226		382		24MHz, -40 °C
		228		388		24MHz, 25 °C
		210		441		24MHz, 105 °C
	Clock Duty	45	50	55	%	

Table 8.4-1 External 4~24 MHz High Speed Crystal (HXT) Oscillator

8.4.1.1 Typical Crystal Application Circuits

CRYSTAL	C1	C2	R
4MHz ~ 24 MHz	20pF	20pF	without

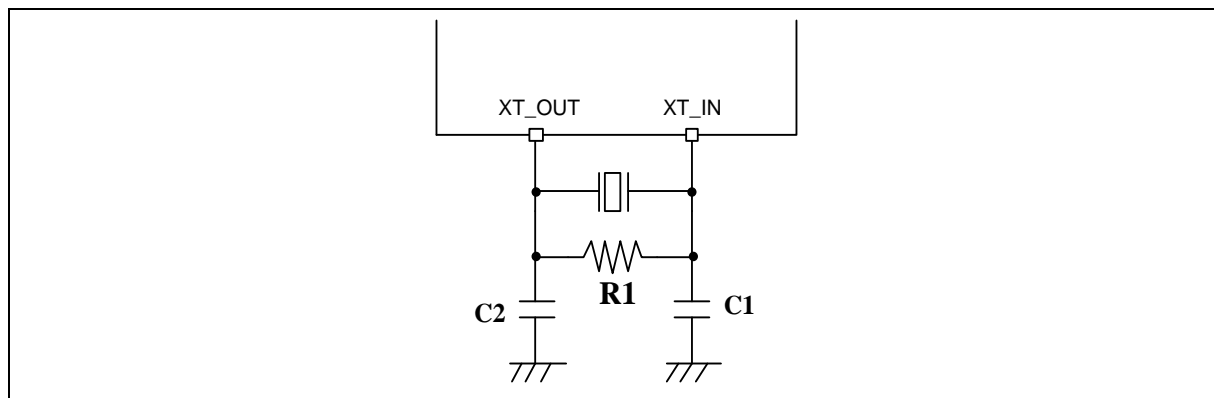

Figure 8.4-1 Typical Crystal Application Circuit

8.4.2 External 4~24 MHz High Speed Clock Input (OSC) Characteristics

SYM.	PARAMETER	SPECIFICATIONS				TEST CONDITION
		MIN.	TYP.	MAX.	UNIT	
t _{CHCX}	Clock High Time	18			nS	
t _{CLCX}	Clock Low Time	18			nS	

SYM.	PARAMETER	SPECIFICATIONS				TEST CONDITION
		MIN.	TYP.	MAX.	UNIT	
t _{CLCH}	Clock Rise Time			10	nS	
t _{CHCL}	Clock Fall Time			10	nS	
V _{IH}	Input High Voltage			0.7*V _{DD}	V	
V _{IL}	Input Low Voltage	0.3*V _{DD}			V	

Note: Duty cycle is 50%.

Notes: Guaranteed by design, not tested in production

8.4.3 External 32.768 kHz Low Speed Crystal (LXT) characteristics

SYM.	PARAMETER	SPECIFICATIONS				TEST CONDITION
		MIN.	TYP.	MAX.	UNIT	
V _{DD}	Operation Voltage	1.8		3.6	V	
f _{LXT}	Oscillator frequency		32.768		kHz	V _{DD} = 1.8 ~ 3.6 V
T _{LXT}	Temperature	-40		105	°C	
I _{LXT}	Operating current			0.5	μA	V _{DD} = 3.3V
	Duty cycle	45		55	%	
T _S	Stable Time			500	ms	

Table 8.4-2 External 32.768 kHz Crystal

8.4.3.1 Typical Crystal Application Circuits

CRYSTAL	C1	C2	R1
32.768 kHz	20pF	20pF	without

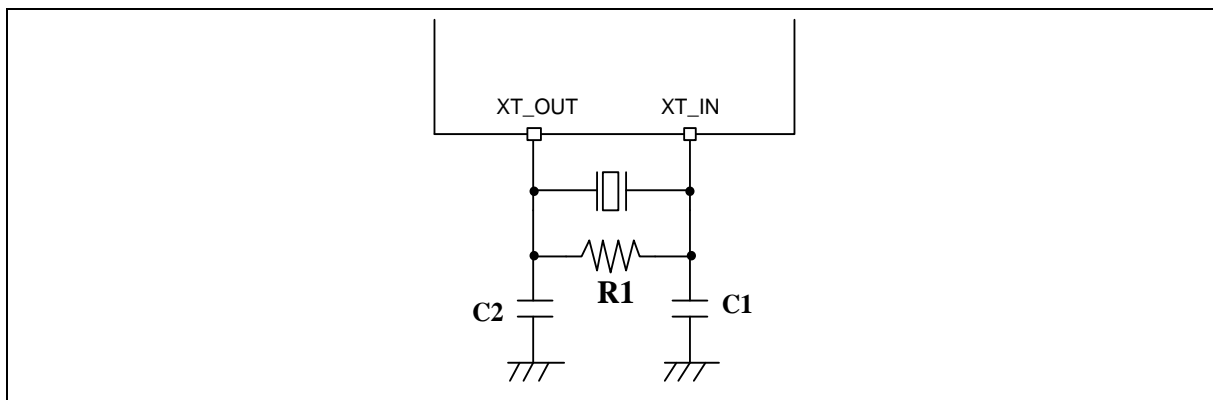
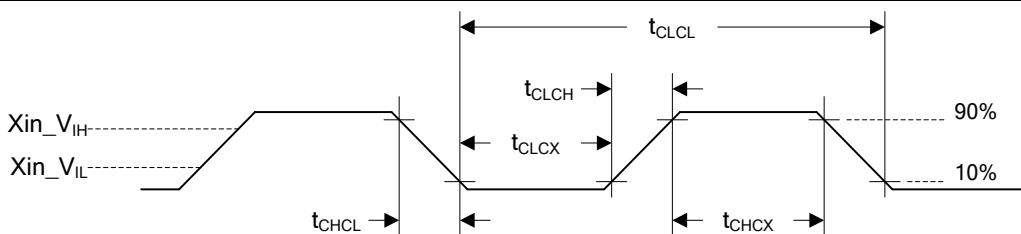

Figure 8.4-2 Typical Crystal Application Circuit

8.4.4 External 32.768 kHz Low Speed Clock Input (OSC) Characteristics

PARAMETER	SYM.	SPECIFICATIONS				TEST CONDITION
		MIN.	TYP.	MAX.	UNIT	
Clock High Time	t_{CHCX}	450	-	-	nS	
Clock Low Time	t_{CLCX}	450	-	-	nS	
Clock Rise Time	t_{CLCH}		-	50	nS	
Clock Fall Time	t_{CHCL}		-	50	nS	
LXT Input Pin Input High Voltage	Xin_VIH			$0.7 \cdot V_{DD}$	V	
LXT Input Pin Input Low Voltage	Xin_VIL	$0.3 \cdot V_{DD}$			V	



Note: Duty cycle is 50%.

Note: Duty cycle is 50%.

Notes: Guaranteed by design, not tested in production

8.4.5 12 MHz Internal High Speed RC Oscillator (HIRC)

SYM.	PARAMETER	SPECIFICATIONS				TEST CONDITION
		MIN.	TYP.	MAX.	UNIT	
V_{HRC}	Supply voltage	1.8		3.6	V	
f_{HRC}	Center Frequency		12		MHz	

SYM.	PARAMETER	SPECIFICATIONS				TEST CONDITION
		MIN.	TYP.	MAX.	UNIT	
	Internal Oscillator Frequency[*1]	-1		1	%	T _A = 25 °C, V _{DD} = 3.3V
		-2		2	%	-40°C ~ +105 °C, V _{DD} = 1.8 ~ 3.6V
I _{HRC}	Operating current		155		μA	
T _S	Stable time			4	us	

Note: Guaranteed by characterization, not tested in production

8.4.6 10 kHz Internal Low Speed RC Oscillator (LIRC)

SYM.	PARAMETER	SPECIFICATIONS				TEST CONDITION
		MIN.	TYP.	MAX.	UNIT	
V _{LRC}	Supply voltage	1.8		3.6	V	
F _{LRC}	Oscillator Frequency[*1]	5		20	kHz	V _{DD} =1.8V~3.6V, T _A =-40~105°C
I _{LRC}	Operating current			0.5	μA	V _{DD} = 3.3V
T _S	Stable time		200		μs	

Note: Guaranteed by characterization, not tested in production

8.4.7 PLL Characteristics

Symbol	Parameter	Conditions	Min	Typ	Max	Unit
f _{PLL_IN}	PLL input clock		4		24	MHz
f _{PLL_OUT}	PLL multiplier output clock		50		500	MHz
T _S	PLL stable time[*1]		100		200	μs
Jitter	Cycle-to-cycle Jitter[*2]	Peak to peak @ 480M		250		ps
I _{DD}	Power consumption	V _{DD} =3.3V@500MHz			3	mA

Note:

1. Guaranteed by characterization, not tested in production
2. Guaranteed by design, not tested in production

8.4.8 PIN AC Characteristics

- C_L = 51 pF

Px_SLEWCTL	Symbol	Parameter	Conditions	Typ	Unit

00	t _f (IO) _{out}	Output high to low level fall time (90~10%)	V _{DD} = 3.6 V	4.384	ns
			V _{DD} = 1.8 V	8.532	
	t _r (IO) _{out}	output low to high level rise time (10~90%)	V _{DD} = 3.6 V	4.086	
			V _{DD} = 1.8 V	8.225	
01	t _f (IO) _{out}	Output high to low level fall time (90~10%)	V _{DD} = 3.6 V	3.005	
			V _{DD} = 1.8 V	6.153	
	t _r (IO) _{out}	output low to high level rise time (10~90%)	V _{DD} = 3.6 V	3.404	
			V _{DD} = 1.8 V	6.29	
10	t _f (IO) _{out}	Output high to low level fall time (90~10%)	V _{DD} = 3.6 V	3.054	
			V _{DD} = 1.8 V	6.152	
	t _r (IO) _{out}	output low to high level rise time (10~90%)	V _{DD} = 3.6 V	3.389	
			V _{DD} = 1.8 V	6.269	

Table 8.4-3 I/O AC Characteristics

8.5 Analog Electrical Characteristics

8.5.1 LDO

Symbol	Parameter	Min	Typ	Max	Unit	Test Condition
V _{DD}	DC Power Supply	1.8		3.6	V	
V _{LDO}	Output Voltage	1.08	1.26	1.32	V	
T _A	Temperature	-40		105	°C	

Note:

1. It is recommended a 0.1µF bypass capacitor is connected between V_{DD} and the closest V_{SS} pin of the device.
2. For ensuring power stability, a 2.2µF capacitor must be connected between LDO_CAP pin and the closest V_{SS} pin of the device.

8.5.2 Low-Voltage Reset

Symbol	Parameter	Min	Typ	Max	Unit	Test Condition
AV _{DD}	Supply Voltage	0		3.6	V	
T _A	Temperature	-40		105	°C	-
I _{LVR}	Operating Current		0.5		µA	AV _{DD} = 3.6V
V _{LVR}	Threshold Voltage	1.40	1.48	1.56	V	T _A = 105 °C
		1.40	1.48	1.56	V	T _A = 25 °C
		1.40	1.48	1.56	V	T _A = -40 °C

8.5.3 Brown-out Detector

Symbol	Parameter	Min	Typ	Max	Unit	Test Condition
AV _{DD}	Supply Voltage	0		3.6	V	-
T _A	Temperature	-40		105	°C	-
I _{BOD}	Operating Current		66		µA	AV _{DD} = 3.6V
V _{BOD_F}	Brown-out Voltage (Falling edge)	2.9	3.0	3.1	V	BODVL [2:0] = 111
		2.7	2.8	2.9	V	BODVL [2:0] = 110
		2.5	2.6	2.7	V	BODVL [2:0] = 101
		2.3	2.4	2.5	V	BODVL [2:0] = 100
		2.1	2.2	2.3	V	BODVL [2:0] = 011
		1.9	2.0	2.1	V	BODVL [2:0] = 010
		1.7	1.8	1.9	V	BODVL [2:0] = 001
		1.5	1.6	1.7	V	BODVL [2:0] = 000
V _{BOD_R}	Brown-out Voltage (Rising edge)	3.0	3.1	3.2	V	BODVL [2:0] = 111
		2.8	2.9	3.0	V	BODVL [2:0] = 110
		2.6	2.7	2.8	V	BODVL [2:0] = 101

		2.4	2.5	2.6	V	BODVL [2:0] = 100
		2.2	2.3	2.4	V	BODVL [2:0] = 011
		2.0	2.1	2.2	V	BODVL [2:0] = 010
		1.8	1.9	2.0	V	BODVL [2:0] = 001
		1.6	1.7	1.8	V	BODVL [2:0] = 000
T _{BOD_RE}	Respond Time		1		ms	Respond Time

8.5.4 Power-on Reset

Symbol	Parameter	Min	Typ	Max	Unit	Test Condition
T _A	Temperature	-40	-	+105	°C	-
V _{POR}	Reset Voltage		1.47		V	-
RR _{VDD}	V _{DD} Raising Rate to Ensure Power-on Reset[*1]	10			us/V	
FR _{VDD}	V _{DD} Falling Rate to Ensure Power-on Reset[*1]	320			us/V	

Note: Guaranteed by characterization, not tested in production

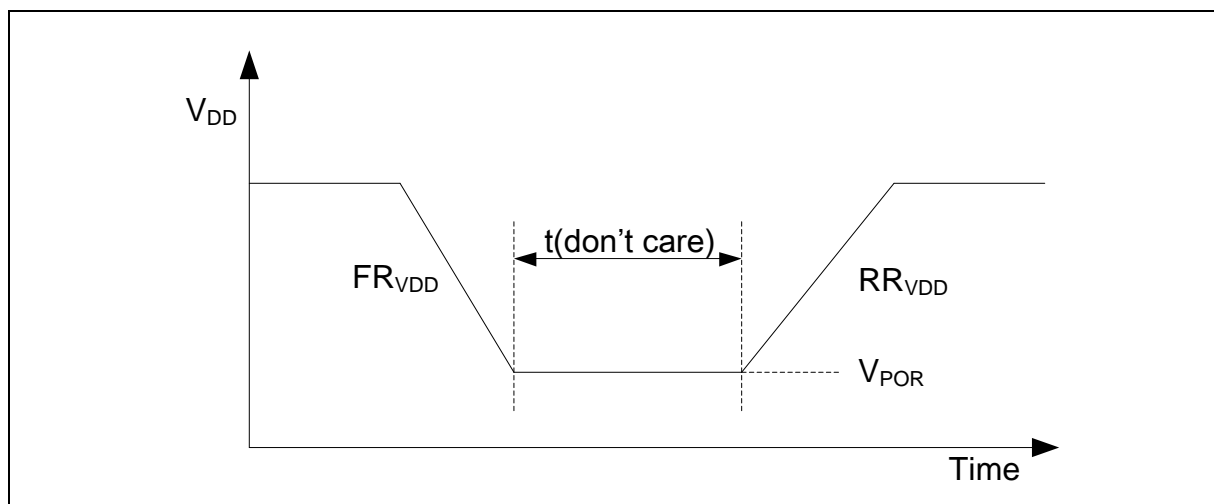

Figure 8.5-1 Power-up Ramp Condition

8.5.5 Internal Voltage Reference

- The maximum values are obtained for V_{DD} = 3.6 V and maximum ambient temperature (T_A), and the typical values for T_A = 25 °C and V_{DD} = 3.3 V unless otherwise specified.

Symbol	Parameter	Min	Typ	Max	Unit	Comments
V _{REF_INT}	Internal reference voltage		1.6		V	
			2.0			
			2.5			
			3.0			

AV _{DD_min}	AV _{DD} minimum voltage	2			V	V _{REF_OUT} = 1.6 V
		2.2				V _{REF_OUT} = 2.0 V
		2.7				V _{REF_OUT} = 2.5 V
		3.2				V _{REF_OUT} = 3.0 V
T _s	Stable time		0.7	2	ms	C _L = 4.7 uF, V _{REF} initial=0
			35	48	us	C _L = 0.1 uF, V _{REF} initial=0

Note: Guaranteed by characterization, not tested in production

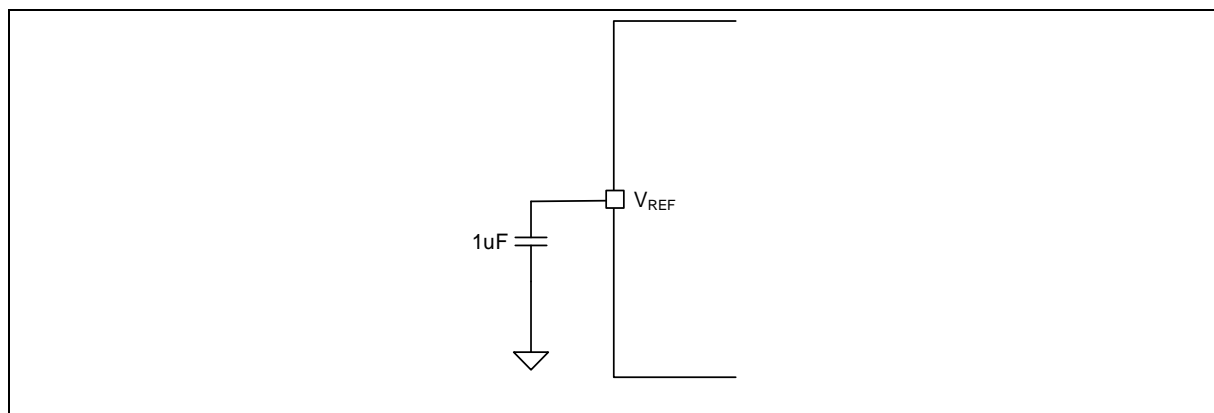

Figure 8.5-2 Typical Connection with Internal Voltage Reference

8.5.6 12-bit ADC

Fast Speed Channel

SYM.	PARAMETER	SPECIFICATIONS				TEST CONDITION
		MIN.	TYP.	MAX.	UNIT	
AV _{DD}	Operating voltage	1.8		3.6	V	AV _{DD} = V _{DD}
V _{REF}	Reference voltage	1.6		AV _{DD}	V	
T _A	Temperature	-40		105	°C	
I _{ADC}	Operating current (AV _{DD} current) (Enable ADC and disable all other analog modules)	478		523	uA	AV _{DD} = V _{DD} = V _{REF} = 3.3V ADC Clock Rate = 70 MHz High speed channel
	Resolution			12	Bit	
V _{IN}	ADC channel input voltage	0		V _{REF}	V	
F _{ADC}	ADC Clock frequency	0.14		70	MHz	High speed channel
T _{SMP}	Sampling Time		2		1/F _{ADC}	
T _{CONV}	Conversion time		14		1/F _{ADC}	T _{CONV} = T _{SMP} + 12
F _{SPS}	Sampling Rate (F _{ADC} /T _{CONV})			5	MSPS	High speed channel

SYM.	PARAMETER	SPECIFICATIONS				TEST CONDITION
		MIN.	TYP.	MAX.	UNIT	
T _{PU}	Power-up time	20			μs	
INL	Integral Non-Linearity Error	-4.29		-3.71	LSB	V _{REF} = AV _{DD}
DNL	Differential Non-Linearity Error	3.25		3.28	LSB	V _{REF} = AV _{DD}
E _G	Gain error	2.25		2.31	LSB	V _{REF} = AV _{DD}
E _{OFFSET}	Offset error	1.56		2.87	LSB	V _{REF} = AV _{DD}
E _A	Absolute Error	4.5		4.94	LSB	V _{REF} = AV _{DD}
C _{IN}	Internal Capacitance[*1]		5		pF	
-	Monotonic	Guaranteed			-	

Low Speed Channel

SYM.	PARAMETER	SPECIFICATIONS				TEST CONDITION
		MIN.	TYP.	MAX.	UNIT	
AV _{DD}	Operating voltage	1.8		3.6	V	AV _{DD} = V _{DD}
V _{REF}	Reference voltage		AV _{DD}		V	
T _A	Temperature	-40		105	°C	
I _{ADC1}	Operating current (AV _{DD} current) (Enable ADC and disable all other analog modules)	210		231	uA	AV _{DD} = V _{DD} = V _{REF} = 3.3V ADC Clock Rate = 28 MHz low speed channel
		131		142		AV _{DD} = V _{DD} = V _{REF} = 1.8V ADC Clock Rate = 28 MHz low speed channel
I _{ADC2}		111		123	uA	AV _{DD} = V _{DD} = V _{REF} = 3.3V ADC Clock Rate = 14 MHz low speed channel
		70		78		AV _{DD} = V _{DD} = V _{REF} = 1.8V ADC Clock Rate = 14 MHz low speed channel
	Resolution			12	Bit	
V _{IN}	ADC channel input voltage	0		V _{REF}	V	
F _{ADC}	ADC Clock frequency	0.14		28	MHz	Low speed channel
T _{SMP}	Sampling Time		2		1/F _{ADC}	
T _{CONV}	Conversion time		14		1/F _{ADC}	T _{CONV} = T _{SMP} + 12
F _{SPS}	Sampling Rate (F _{ADC} /T _{CONV})			2	MSPS	Low speed channel
T _{PU}	Power-up time	20			μs	
INL	Integral Non-Linearity Error	-2.94		-1.32	LSB	V _{REF} = AV _{DD}
DNL	Differential Non-Linearity Error	1.25		2	LSB	V _{REF} = AV _{DD}
E _G	Gain error	2.5		3.12	LSB	V _{REF} = AV _{DD}
E _{OFFSET}	Offset error	2.44		3.69	LSB	V _{REF} = AV _{DD}

SYM.	PARAMETER	SPECIFICATIONS				TEST CONDITION
		MIN.	TYP.	MAX.	UNIT	
E _A	Absolute Error	4.69		6.75	LSB	V _{REF} = AV _{DD}
C _{IN}	Internal Capacitance[*1]		5		pF	
-	Monotonic	Guaranteed			-	

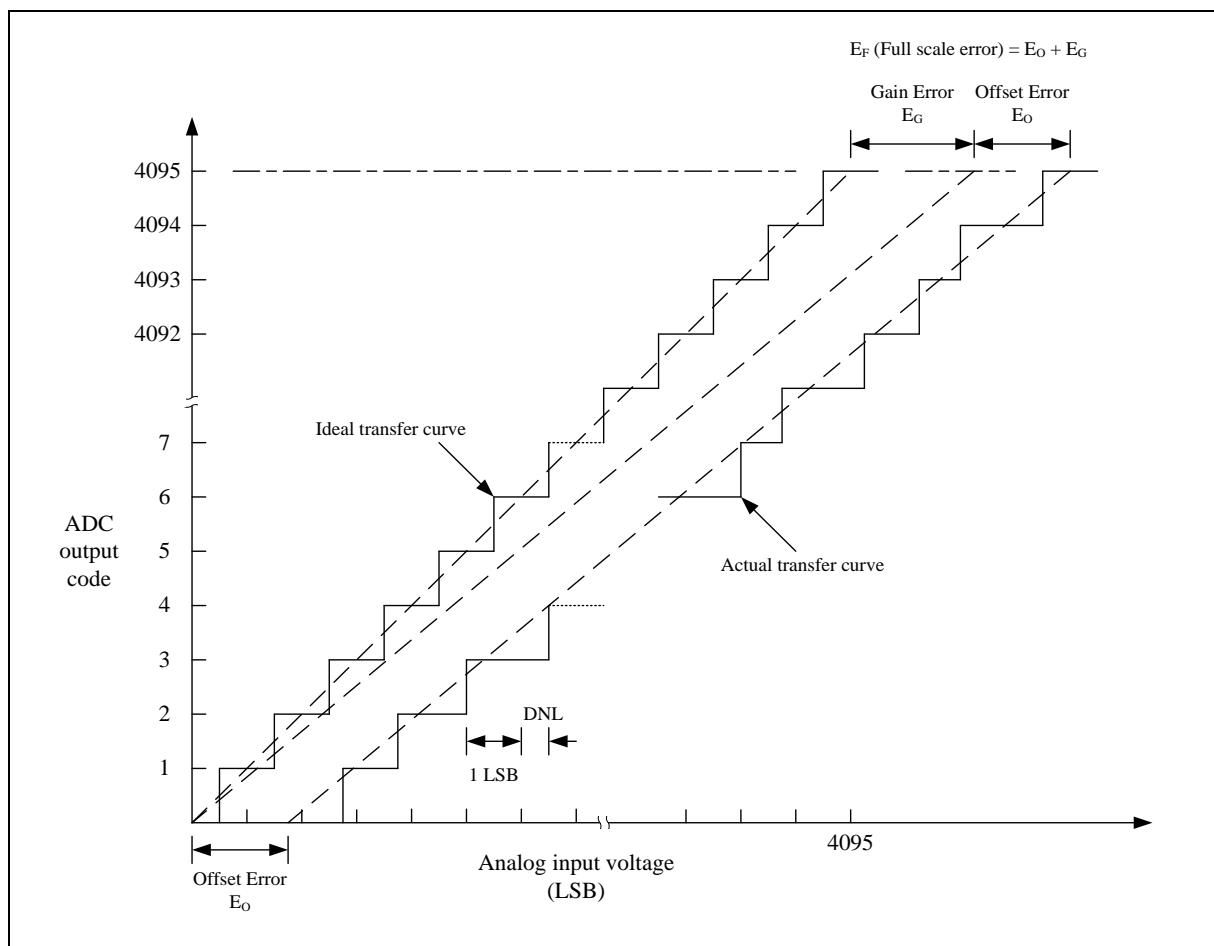

Note: The INL is the peak difference between the transition point of the steps of the calibrated transfer curve and the ideal transfer curve. A calibrated transfer curve means it has calibrated the offset and gain error from the actual transfer curve.

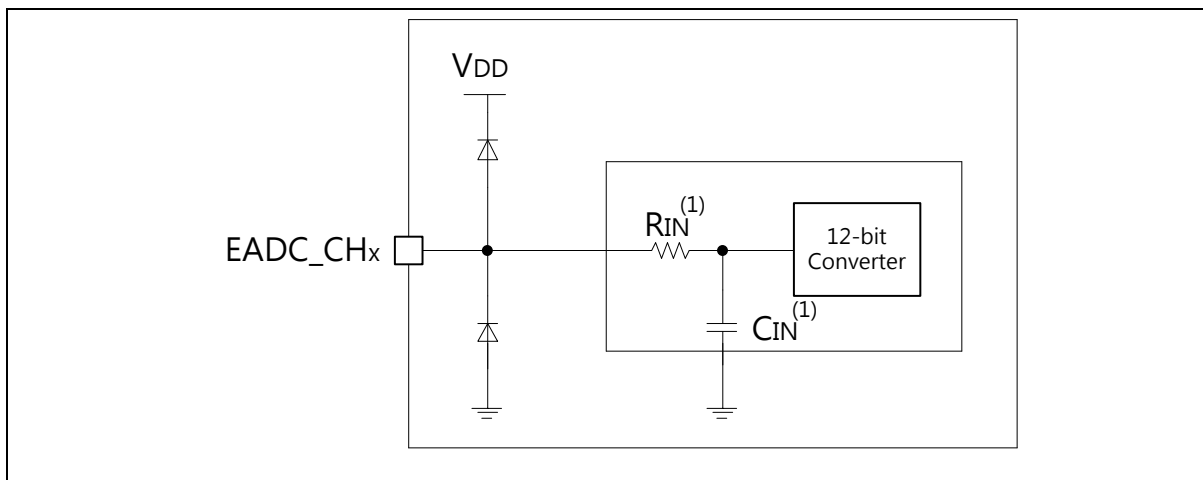

Note: GND < EADC_CHx < V_{REF}

(1) Refer to ADC spec for the values of R_{IN}, C_{IN}

8.5.7 Temperature Sensor

Symbol	Parameter	Min	Typ	Max	Unit
V _{DD}	Operating Voltage	1.8		3.6	V
T _A	Temperature Range	-40		105	°C
I _{TEMP}	Current Consumption [*3]		16		μA
T _c	Temperature Coefficient [*3]	-1.77	-1.82	-1.84	mV/°C
V _{os}	Offset Voltage when T _A = 0°C [*3]	710.2		716.8	mV
t _S	Stable time[*2]		1		μs
T _{S_temp}	ADC sampling time when reading the temperature (5pF cap load) [*1]		3		μs

Note:

1. V_{TEMP} (mV) = T_c (mV/°C) x Temperature (°C) + V_{os} (mV)
2. Guaranteed by design, not tested in production
3. Guaranteed by characteristic, not tested in production

8.5.8 Digital to Analog Converter (DAC)

Symbol	Parameter	Min	Typ	Max	Unit	Test Condition
AV _{DD}	Analog supply voltage	1.8	-	3.6	V	-
N _R	Resolution	12			bit	-
V _{REF}	Reference supply voltage	1.5	-	AV _{DD}	V	V _{REF} ≤ AV _{DD}
DNL	Differential non-linearity error[*4]	-	-	±2	LSB	12-bit mode
		-	-	±0.5	LSB	10-bit mode
INL	Integral non-linearity error[*4]	-	-	±4	LSB	12-bit mode
		-	-	±1	LSB	10-bit mode

OE	Offset Error[*4]	-	-	±6	LSB	12-bit mode DACOUT buffer ON
		-	-	±4	LSB	12-bit mode DACOUT buffer OFF
		-	-	±2	LSB	10-bit mode
GE	Gain Error[*4]	-	-	±5	LSB	12-bit mode DACOUT buffer ON
		-	-	±4	LSB	12-bit mode DACOUT buffer OFF
		-	-	±2	LSB	10-bit mode
AE	Absolute Error[*4]	-	-	±8	LSB	12-bit mode DACOUT buffer ON
		-	-	±4	LSB	12-bit mode DACOUT buffer OFF
		-	-	±2	LSB	10-bit mode
-	Monotonic	10-bit guaranteed			-	-
V _O	Output Voltage	0.2		AV _{DD} - 0.2	V	DACOUT buffer ON
R _{LOAD}	Resistive load[*2]	7.5	-	-	kΩ	DACOUT buffer ON
R _o	Output impedance[*4]		10	12	kΩ	DACOUT buffer OFF
C _{LOAD}	Capacitive load[*3]	-	-	50	pF	-
I _{AVDD}	Current consumption on AV _{DD} supply[*4]	-	-	180	μA	AV _{DD} = 3.6V, no load, lowest code (0x000)
		-	-	420		AV _{DD} = 3.6V, no load, middle code (0x800)
I _{REF}	Current consumption on V _{REF} supply[*4]	-	150	240	μA	V _{REF} = 3.6V, no load, middle code (0x800)
T _s	Settling Time	-	5	6	μs	Full scale: for a 12-bit input code transition between the lowest and the highest input codes when DAC_OUT reaches final value +/-1 LSB, C _{LOAD} ≤ 50pF, R _{LOAD} ≥ 7.5kΩ
F _s	Update Rate	-	-	1	MSPS	Max. frequency for a correct DAC_OUT change from core i to i+1LSB, C _{LOAD} ≤ 50pF, R _{LOAD} ≥ 7.5kΩ
T _{WAKEUP}	Wake-up Time	-	9	15	μs	Wakeup time from OFF state. Input code between lowest and highest possible codes. DAC clock source = 1MHz
PSRR	Power Supply Rejection Ratio[*1]	-	-60	-40	dB	No R _{LOAD} , C _{LOAD} = 50pF

Note:

1. Guaranteed by design, not tested in production.
2. Resistive load between DACOUT and AV_{SS}.
3. Capacitive load at DACOUT pin.
4. Guaranteed based on test during characterization.

8.5.9 Analog Comparator Controller (ACMP)

- The maximum values are obtained for $V_{DD} = 3.6\text{ V}$ and maximum ambient temperature (T_A), and the typical values for $T_A = 25\text{ °C}$ and $V_{DD} = 3.3\text{ V}$ unless otherwise specified.

Symbol	Parameter	Min	Typ	Max	Unit	Comments
AV_{DD}	Analog supply voltage	1.8		3.6	V	
T_A	Temperature	-40		105	°C	
I_{DD}	Operating current		1.2		μA	MODESEL[1:0] = 00
			3			MODESEL[1:0] = 01
			10			MODESEL[1:0] = 10
			75			MODESEL[1:0] = 11
V_{CM}	Input common mode voltage range [*2]	0.1	1/2 AV_{DD}	$AV_{DD} - 0.1$		
V_{DI}	Differential input voltage sensitivity [*2]	10	20		mV	Hysteresis disable
V_{offset}	Input offset voltage		5	10	mV	Hysteresis disable,
V_{hys}	Hysteresis window		0		mV	HYSSEL[1:0] = 00
			10			HYSSEL[1:0] = 01
			20			HYSSEL[1:0] = 10
			30			HYSSEL[1:0] = 11
A_v	DC voltage Gain[*1]		70		dB	
T_d	Propagation delay[*2]			0.2	μs	Hysteresis disable MODESEL[1:0] = 00
				0.6		Hysteresis disable MODESEL[1:0] = 01
				2		Hysteresis disable MODESEL[1:0] = 10
				4.5		Hysteresis disable MODESEL[1:0] = 11
T_{Setup}	Setup time[*2]			0.45	μs	Hysteresis disable MODESEL[1:0] = 00
				0.85		Hysteresis disable MODESEL[1:0] = 01
				2.25		Hysteresis disable MODESEL[1:0] = 10
				4.75		Hysteresis disable MODESEL[1:0] = 11

Note:

- Guaranteed by design, not tested in production
- Guaranteed by characteristic, not tested in production

8.5.10 OP Amplifier (OPA)

- The maximum values are obtained for $V_{DD} = 3.6\text{ V}$ and maximum ambient temperature (T_A), and the typical values for $T_A = 25\text{ °C}$ and $V_{DD} = 3.3\text{ V}$ unless otherwise specified.

Symbol	Parameter	Min	Typ	Max	Unit	Comments
AVDD	Analog supply voltage	2.4		3.6	V	
T _A	Temperature	-40		105	°C	
I _{DD}	Consumption current		690		μA	A _{VDD} =3.3V, Temperature=25 °C
CMIR	Common mode input range	0		A _{VDD}	V	
V _{OFFSET0}	Input offset voltage(maximum calibration range) [*2]			4	mV	T _j = 25°C, No Load V _{CM} = A _{VDD} -10mV ~ A _{VDD} -0.8V, All Temp.
				6		CALRVS =0: Other V _{CM}
V _{OFFSET1}	Input offset voltage(After offset calibration) [*2]			3.2		CALRVS=0: V _{CM} = A _{VDD} -10mV ~ A _{VDD} -0.8V
				6.5		CALRVS =1: Other V _{CM}
V _{OFFSET2}	Input offset voltage(After offset calibration) [*2]			3		CALRVS =1: V _{CM} = A _{VDD} -10mV ~ A _{VDD} -0.8V
				5.2		
CMRR	Common Mode Rejection Ratio [*1]		90		dB	
PSRR	Power Supply Rejection Ratio [*1]	73	117		dB	
GBW	Bandwidth [*2]		8.2		MHz	
SR	Slew rate [*2]		4.7		V/μs	
V _{OHSAT}	High saturation voltage [*2]	A _{VDD} -0.1			V	R _{load} =min. INPUT at A _{VDD}
		A _{VDD} -0.02				R _{load} =20K, INPUT at A _{VDD}
V _{OLSAT}	Low saturation voltage [*2]			100	mV	R _{load} =min. INPUT at 0
				20		R _{load} =20K, INPUT at 0
PM	Phase Margin [*1]		62		degree	
T _{WAKEUP}	Wake up time from OFF state [*2]		2.8	5	μs	
R _{LOAD}	Resistive load	4			kΩ	
C _{LOAD}	Capacitive load			50	pF	

Note:

1. Guaranteed by design, not tested in production
2. Guaranteed by characteristic, not tested in production

8.6 Flash DC Electrical Characteristic

Symbol	Parameter	Min	Typ	Max	Unit	Test Condition
V _{FLA} ^[1]	Supply Voltage	1.08		1.32	V	T _A = 25°C
N _{ENDUR}	Endurance	10000	-	-	cycles ^[2]	
T _{RET}	Data Retention	10	-	-	year	
T _{ERASE}	Page Erase Time	92	-	160	mS	
T _{MER}	Mass Erase Time	201	-	320	mS	
T _{PROG}	Program Time	42	-	50	uS	
I _{DD1}	Read Current	-	-	4.12	mA	
I _{DD2}	Program Current	-	-	5	mA	
I _{DD3}	Erase Current	-	-	5	uA	

Note:

1. V_{FLA} is source from chip LDO output voltage.
2. Number of program/erase cycles.
3. This table is guaranteed by design, not test in production.

8.7 I²C Dynamic Characteristics

Symbol	Parameter	Standard Mode ^{[1][2]}		Fast Mode ^{[1][2]}		Unit
		Min.	Max.	Min.	Max.	
t _{LOW}	SCL low period	4.7	-	1.2	-	uS
t _{HIGH}	SCL high period	4	-	0.6	-	uS
t _{SU, STA}	Repeated START condition setup time	4.7	-	1.2	-	uS
t _{HD, STA}	START condition hold time	4	-	0.6	-	uS
t _{SU, STO}	STOP condition setup time	4	-	0.6	-	uS
t _{BUF}	Bus free time	4.7 ^[3]	-	1.2 ^[3]	-	uS
t _{SU, DAT}	Data setup time	250	-	100	-	nS
t _{HD, DAT}	Data hold time	0 ^[4]	3.45 ^[5]	0 ^[4]	0.8 ^[5]	uS
t _r	SCL/SDA rise time	-	1000	20+0.1C _b	300	nS
t _f	SCL/SDA fall time	-	300	-	300	nS
C _b	Capacitive load for each bus line	-	400	-	400	pF

Note:

1. Guaranteed by characteristic, not tested in production
2. HCLK must be higher than 2 MHz to achieve the maximum standard mode I²C frequency. It must be higher than 8 MHz to achieve the maximum fast mode I²C frequency.
3. I²C controller must be retriggered immediately at slave mode after receiving STOP condition.
4. The device must internally provide a hold time of at least 300 ns for the SDA signal in order to bridge the undefined region of the falling edge of SCL.
5. The maximum hold time of the Start condition has only to be met if the interface does not stretch the low period of SCL signal.

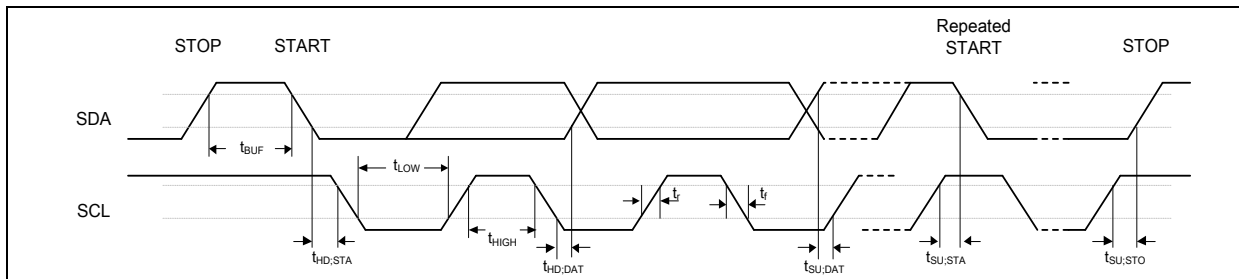

Figure 8.7-1 I²C Timing Diagram

8.8 SPI Dynamic Characteristics

SYMBOL	PARAMETER	MIN.	TYP.	MAX.	UNIT
SPI MASTER MODE (V_{DD} = 3.0~3.6 V, 30 PF LOADING CAPACITOR)					
t _{CLKH}	Clock output High time [*1]			T _{SPICLK} / 2	ns
t _{CLKL}	Clock output Low time [*1]			T _{SPICLK} / 2	ns
t _{DS}	Data setup time	0	-	-	ns
t _{DH}	Data hold time	2	-	-	ns
t _v	Data output valid time	-	0	1	ns
SPI MASTER MODE (V_{DD} = 1.8~2.0 V, 30 PF LOADING CAPACITOR)					
t _{CLKH}	Clock output High time [*1]			T _{SPICLK} / 2	ns
t _{CLKL}	Clock output Low time [*1]			T _{SPICLK} / 2	ns
t _{DS}	Data setup time	0	-	-	ns
t _{DH}	Data hold time	2	-	-	ns
t _v	Data output valid time	-	-	1	ns

Note: The minimum clock period for SPICLK is 10.4 ns (96 MHz).

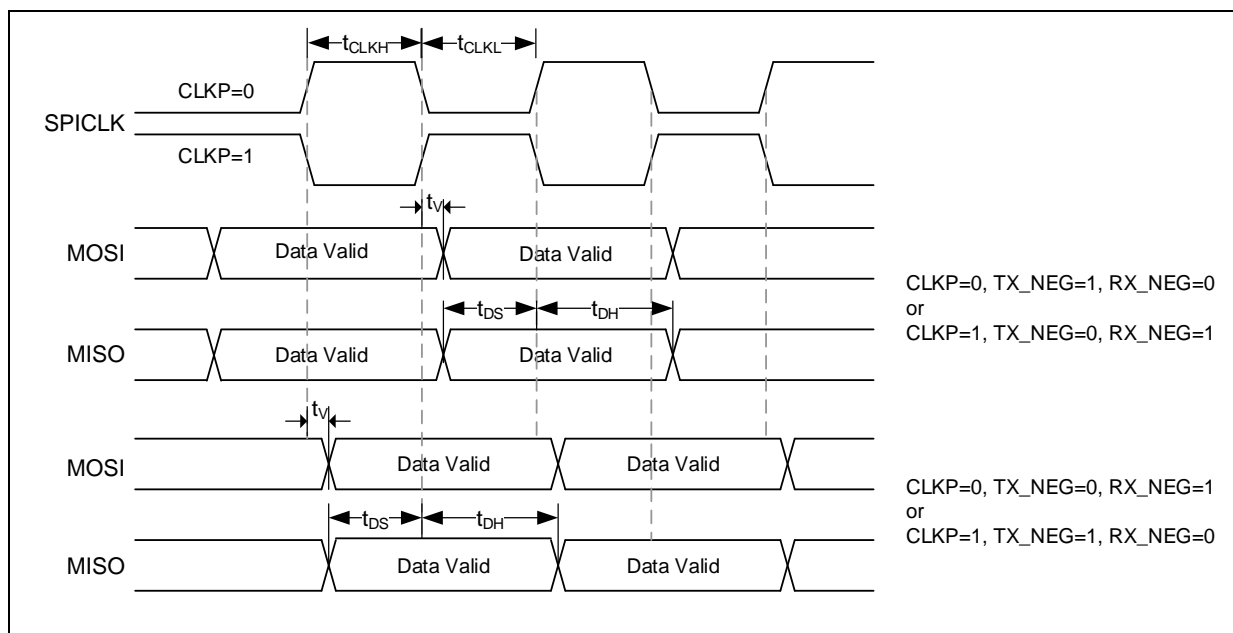

Figure 8.8-1 SPI Master Mode Timing Diagram

SYMBOL	PARAMETER	MIN.	YP.	MAX.	UNIT
--------	-----------	------	-----	------	------

SPI SLAVE MODE (V _{DD} = 3.0~3.6V, 30 PF LOADING CAPACITOR)					
t _{CLKH}	Clock output High time [*1]	-	-	T _{SPICLK} / 2	ns
t _{CLKL}	Clock output Low time [*1]	-	-	T _{SPICLK} / 2	ns
t _{SS}	Slave select setup time	1 T _{SPICLK} + 2ns	-	-	ns
t _{SH}	Slave select hold time	1 T _{SPICLK}	-	-	ns
t _{DS}	Data input setup time	0	-	-	ns
t _{DH}	Data input hold time	2	-	-	ns
t _v	Data output valid time	-	-	8	ns
t _{CLKH}	Clock output High time [*1]	-	-	T _{SPICLK} / 2	ns
SPI SLAVE MODE (V _{DD} = 1.8 V ~ 2.0 V, 30 PF LOADING CAPACITOR)					
t _{CLKH}	Clock output High time [*1]	-	-	T _{SPICLK} / 2	ns
t _{CLKL}	Clock output Low time [*1]	-	-	T _{SPICLK} / 2	ns
t _{SS}	Slave select setup time	1 T _{SPICLK} + 3ns	-	-	ns
t _{SH}	Slave select hold time	1 T _{SPICLK}	-	-	ns
t _{DS}	Data input setup time	0	-	-	ns
t _{DH}	Data input hold time	2	-	-	ns
t _v	Data output valid time	-	-	10	ns

Note: The minimum clock period for SPICLK is 10.4 ns (96 MHz).

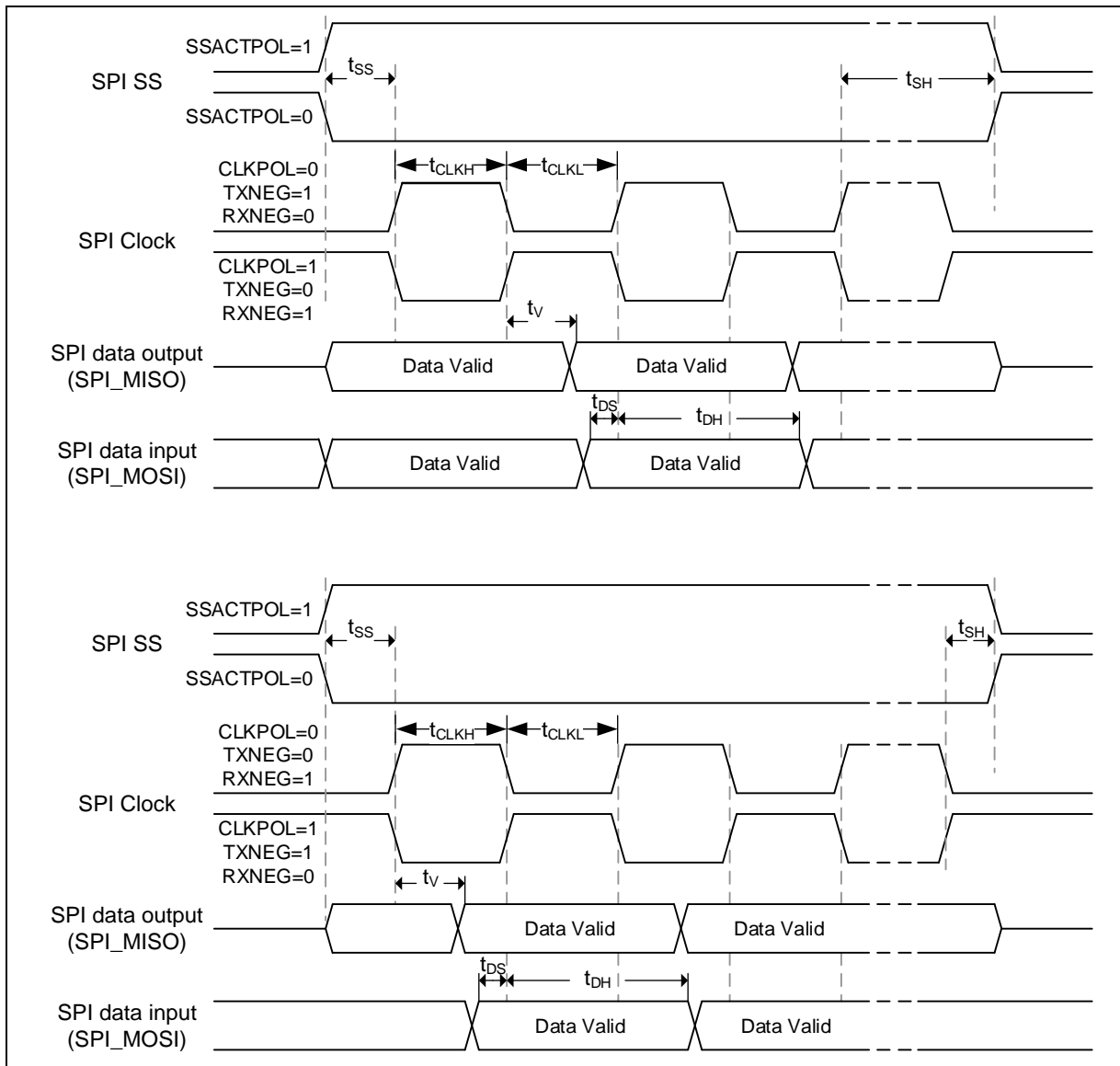

Figure 8.8-2 SPI Slave Mode Timing Diagram

8.9 I²S Dynamic Characteristics

Symbol	Parameter	Min	Max	Unit	Test Conditions
$t_w(\text{CKH})$	I ² S clock high time	40	-	ns	Master $f_{\text{PCLK}} = \text{MHz}$, data: 24 bits, audio frequency = 256 kHz
$t_w(\text{CKL})$	I ² S clock low time	40	-		
$t_v(\text{WS})$	WS valid time	4	16		
$t_h(\text{WS})$	WS hold time	1	-		
$t_{\text{su}}(\text{WS})$	WS setup time	24	-		
$t_h(\text{WS})$	WS hold time	0	-		
$\text{DuCy}(\text{sck})$	I ² S slave input clock duty cycle	30	70	%	Slave mode
$t_{\text{su}}(\text{SD_MR})$	Data input setup time	10	-	ns	Master receiver
$t_{\text{su}}(\text{SD_SR})$		7	-		Slave receiver
$t_h(\text{SD_MR})$	Data input hold time	7	-		Master receiver
$t_h(\text{SD_SR})$		4	-		Slave receiver
$t_v(\text{SD_ST})$	Data output valid time	-	10		Slave transmitter (after enable edge)
$t_h(\text{SD_ST})$	Data output hold time	4	-		Slave transmitter (after enable edge)
$t_v(\text{SD_MT})$	Data output valid time	-	4		Master transmitter (after enable edge)
$t_h(\text{SD_MT})$	Data output hold time	0	-		Master transmitter (after enable edge)

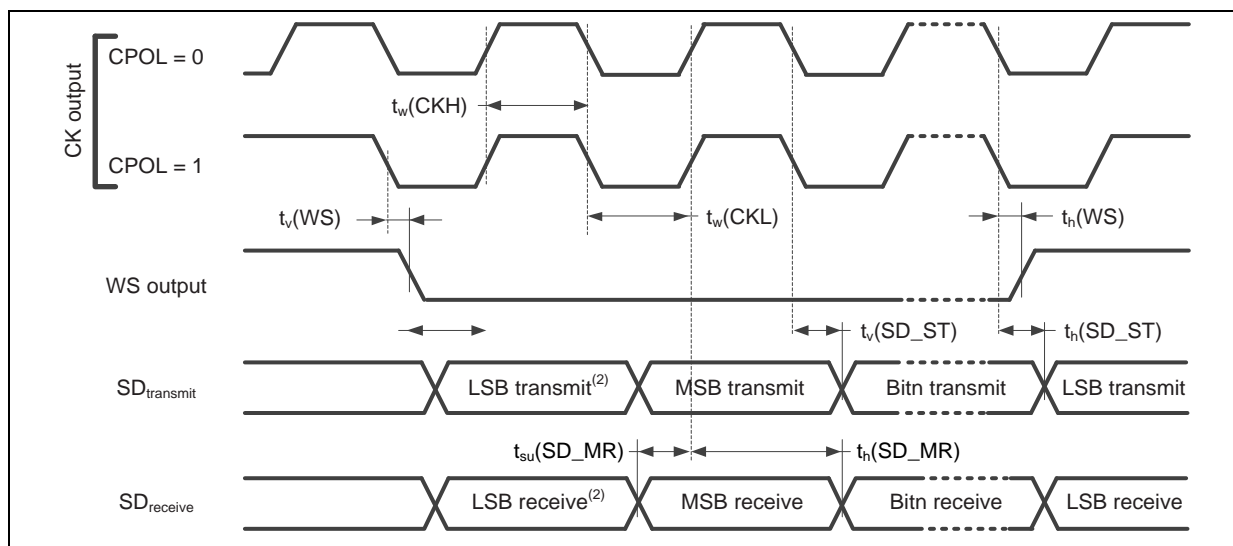

Figure 8.9-1 I²S Master Mode Timing Diagram

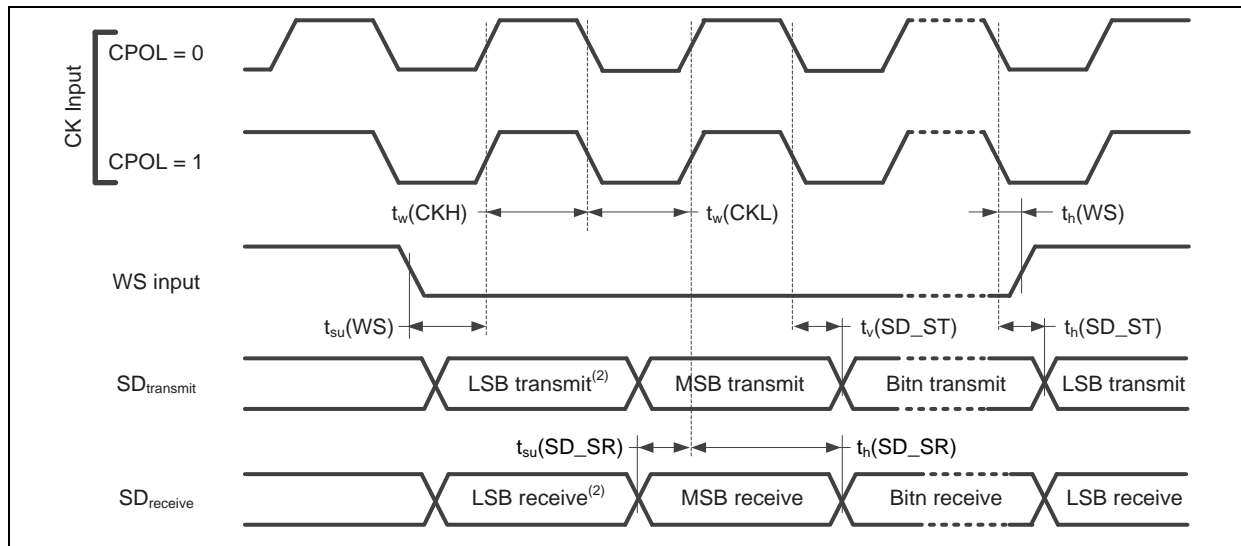

Figure 8.9-2 I²S Slave Mode Timing Diagram

8.10 USCI - I²C Dynamic Characteristics

Symbol	Parameter	Standard Mode ^{[1][2]}		Fast Mode ^{[1][2]}		Unit
		Min.	Max.	Min.	Max.	
t _{LOW}	SCL low period	4.7	-	1.2	-	uS
t _{HIGH}	SCL high period	4	-	0.6	-	uS
t _{SU, STA}	Repeated START condition setup time	4.7	-	1.2	-	uS
t _{HD, STA}	START condition hold time	4	-	0.6	-	uS
t _{SU, STO}	STOP condition setup time	4	-	0.6	-	uS
t _{BUF}	Bus free time	4.7 ^[3]	-	1.2 ^[3]	-	uS
t _{SU, DAT}	Data setup time	250	-	100	-	nS
t _{HD, DAT}	Data hold time	0 ^[4]	3.45 ^[5]	0 ^[4]	0.8 ^[5]	uS
t _r	SCL/SDA rise time	-	1000	20+0.1C _b	300	nS
t _f	SCL/SDA fall time	-	300	-	300	nS
C _b	Capacitive load for each bus line	-	400	-	400	pF

Note:

1. Guaranteed by characteristic, not tested in production
2. HCLK must be higher than 2 MHz to achieve the maximum standard mode I²C frequency. It must be higher than 8 MHz to achieve the maximum fast mode I²C frequency.
3. I²C controller must be retriggered immediately at slave mode after receiving STOP condition.
4. The device must internally provide a hold time of at least 300 ns for the SDA signal in order to bridge the undefined region of the falling edge of SCL.
5. The maximum hold time of the Start condition has only to be met if the interface does not stretch the low period of SCL signal.

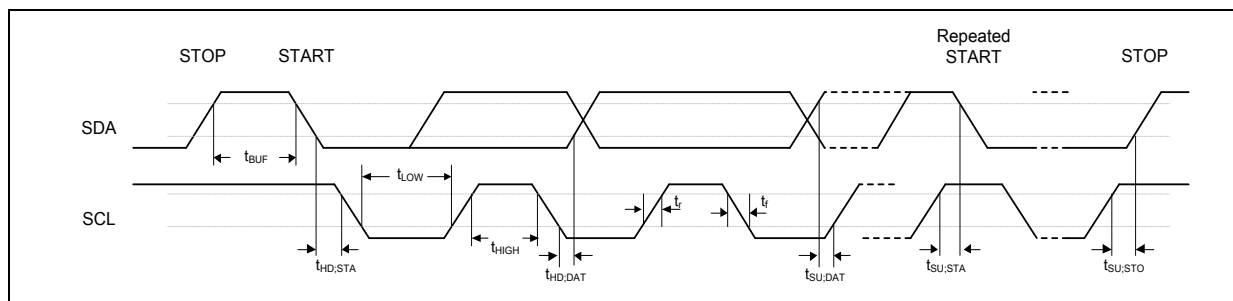

Figure 8.10-1 I²C Timing Diagram

8.11 USCI - SPI Dynamic Characteristics

SYMBOL	PARAMETER	MIN.	TYP.	MAX.	UNIT
SPI MASTER MODE (V_{DD} = 3.0~3.6 V, 30 PF LOADING CAPACITOR)					
t _{CLKH}	Clock output High time [*1]			T _{SPICLK} / 2	ns
t _{CLKL}	Clock output Low time [*1]			T _{SPICLK} / 2	ns
t _{DS}	Data setup time	0	-	-	ns
t _{DH}	Data hold time	2	-	-	ns
t _v	Data output valid time	-	0	1	ns
SPI MASTER MODE (V_{DD} = 1.8~2.0 V, 30 PF LOADING CAPACITOR)					
t _{CLKH}	Clock output High time [*1]			T _{SPICLK} / 2	ns
t _{CLKL}	Clock output Low time [*1]			T _{SPICLK} / 2	ns
t _{DS}	Data setup time	0	-	-	ns
t _{DH}	Data hold time	2	-	-	ns
t _v	Data output valid time	-	-	1	ns

Note: The minimum clock period for SPICLK is 10.4 ns (96 MHz).

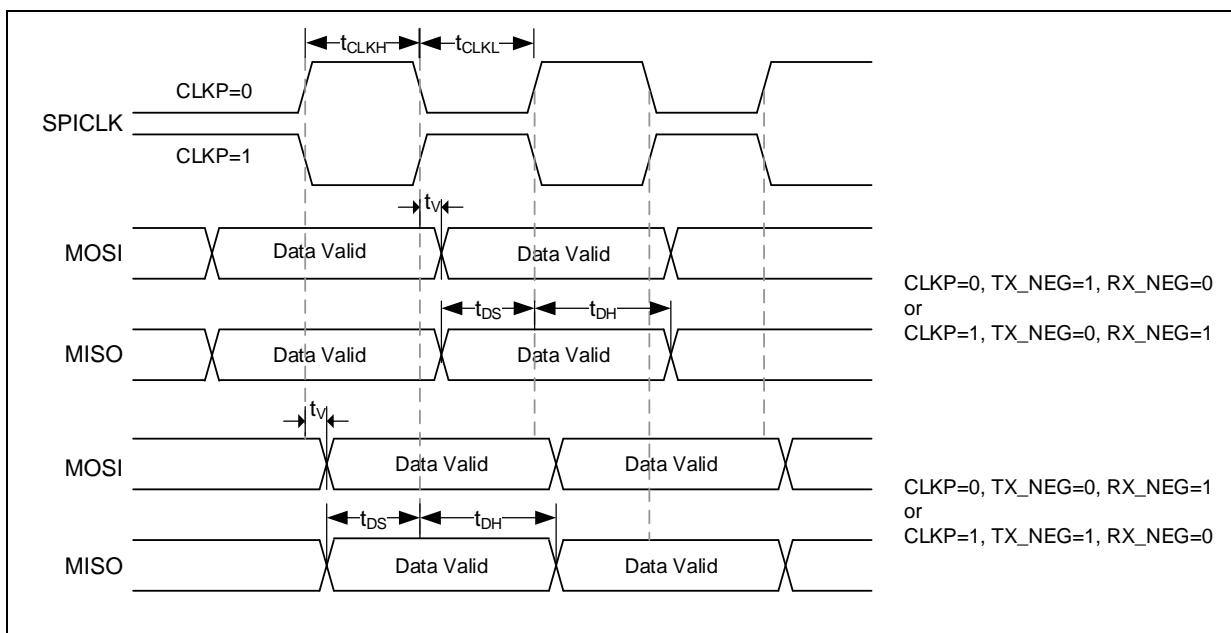

Figure 8.11-1 SPI Master Mode Timing Diagram

SYMBOL	PARAMETER	MIN.	TYP.	MAX.	UNIT
SPI SLAVE MODE (V_{DD} = 3.0~3.6V, 30 PF LOADING CAPACITOR)					

t _{CLKH}	Clock output High time [*1]	-	-	T _{SPICLK} / 2	ns
t _{CLKL}	Clock output Low time [*1]	-	-	T _{SPICLK} / 2	ns
t _{SS}	Slave select setup time	1 T _{SPICLK} + 2ns	-	-	ns
t _{SH}	Slave select hold time	1 T _{SPICLK}	-	-	ns
t _{DS}	Data input setup time	0	-	-	ns
t _{DH}	Data input hold time	2	-	-	ns
t _V	Data output valid time	-	-	8	ns
t _{CLKH}	Clock output High time [*1]	-	-	T _{SPICLK} / 2	ns
SPI SLAVE MODE (V_{DD} = 1.8 V ~ 2.0 V, 30 PF LOADING CAPACITOR)					
t _{CLKH}	Clock output High time [*1]	-	-	T _{SPICLK} / 2	ns
t _{CLKL}	Clock output Low time [*1]	-	-	T _{SPICLK} / 2	ns
t _{SS}	Slave select setup time	1 T _{SPICLK} + 3ns	-	-	ns
t _{SH}	Slave select hold time	1 T _{SPICLK}	-	-	ns
t _{DS}	Data input setup time	0	-	-	ns
t _{DH}	Data input hold time	2	-	-	ns
t _V	Data output valid time	-	-	10	ns

Note: The minimum clock period for SPICLK is 10.4 ns (96 MHz).

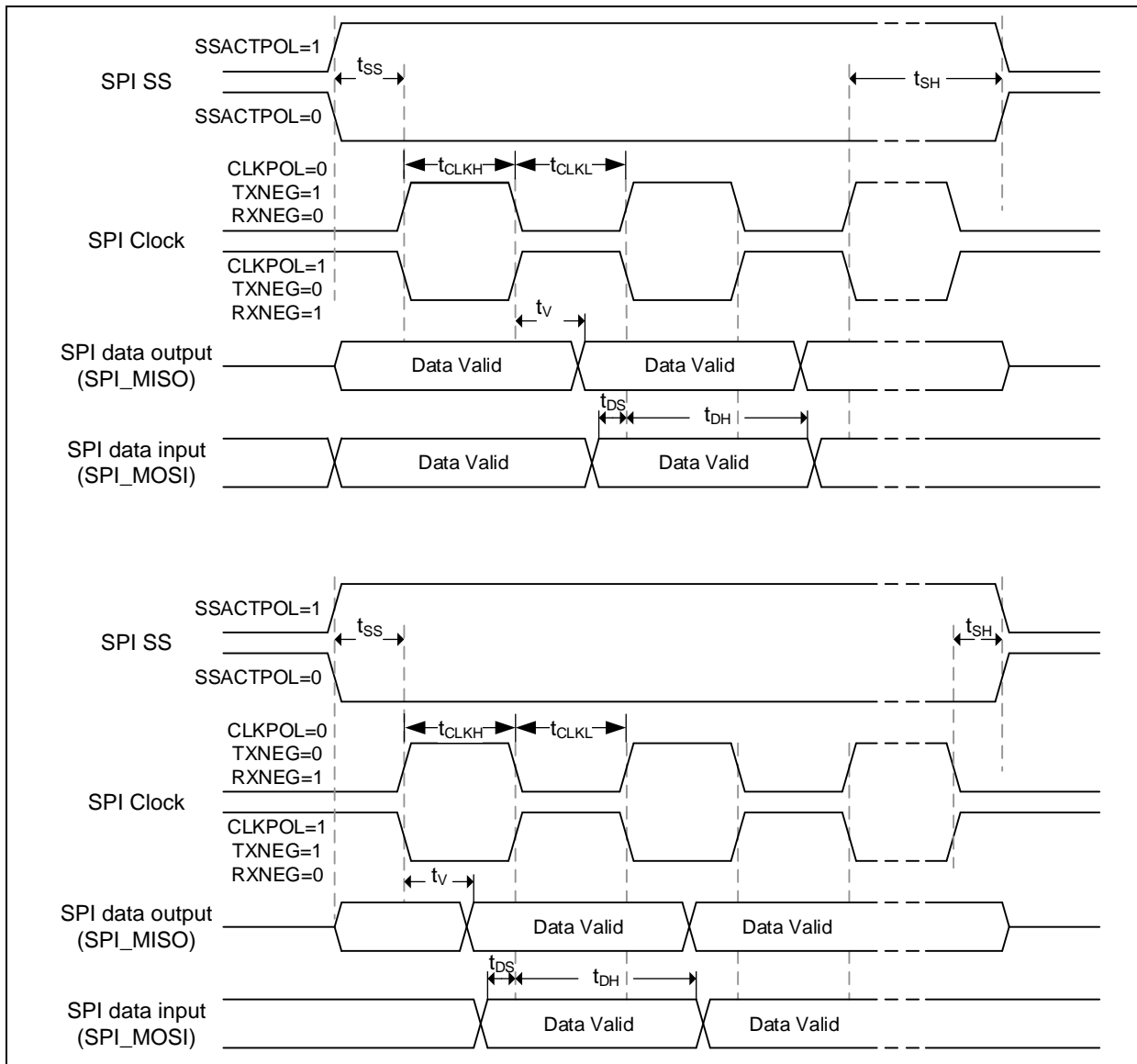

Figure 8.11-2 SPI Slave Mode Timing Diagram

8.12 USB Characteristics

8.12.1 USB Full-Speed

Symbol	Parameter	Min.	Typ.	Max.	Unit	Test Conditions
V _{IH}	Input High (driven)	2.0	-	-	V	-
V _{IL}	Input Low	-	-	0.8	V	-
V _{DI}	Differential Input Sensitivity	0.2	-	-	V	PADP-PADM
V _{CM}	Differential Common-mode Range	0.8	-	2.5	V	Includes V _{DI} range
V _{SE}	Single-ended Receiver Threshold	0.8	-	2.0	V	-
	Receiver Hysteresis	-	200	-	mV	-
V _{OL}	Output Low (driven)	0	-	0.3	V	-
V _{OH}	Output High (driven)	2.8	-	3.6	V	-
V _{CRS}	Output Signal Cross Voltage	1.3	-	2.0	V	-
R _{PU}	Pull-up Resistor	1.425	-	1.575	kΩ	-
R _{PD}	Pull-down Resistor	14.25	-	15.75	kΩ	-
V _{TRM}	TERMINATION Voltage for Upstream port pull up (RPU)	3.0	-	3.6	V	-
Z _{DRV}	Driver Output Resistance	-	13	-	Ω	Steady state drive*
C _{IN}	Transceiver Capacitance	-	-	20	pF	Pin to GND

8.12.2 USB Full-Speed PHY characteristics

Symbol	Parameter	Min.	Typ.	Max.	Unit	Test Conditions
T _{FR}	Rise Time	4	-	20	ns	C _L =50p
T _{FF}	Fall Time	4	-	20	ns	C _L =50p
T _{FRFF}	Rise and Fall Time Matching	90	-	111.11	%	T _{FRFF} =T _{FR} /T _{FF}

8.12.3 USB High-Speed characteristics

Symbol	Parameter	Min	Typ	Max	Unit	Test Condition
T _{FR}	High Speed Driver Rise Time	500	-		ps	CL=5pF
T _{FF}	High Speed Driver Fall Time	500	-		ps	CL=5pF
T _{FRFF}	Rise and Fall Time Matching	90		111.11	%	T _{FRFF} =T _{FR} /T _{FF}

8.13 Ethernet Characteristics

8.13.1 RMII Interface Timing

Symbol	Parameter	Min	Typ	Max	Unit	Test Condition
$T_{P_RMII_REFCLK}$	RMII_REFCLK Period	-	20.0 +/- 50 ppm	-	ns	-
$T_{H_RMII_REFCLK}$	RMII_REFCLK High Time	8.0	10.0	12.0	ns	-
$T_{L_RMII_REFCLK}$	RMII_REFCLK Low Time	8.0	10.0	12.0	ns	-
$T_{DLY_RMII_TX}$	RMII_REFCLK Rising to Valid RMII_TXEN, RMII_TXDATA0 and RMII_TXDATA1 Delay	-	-	10	ns	-
$T_{SU_RMII_RX}$	RMII_CRSDV, RMII_RXDATA0 and RMII_RXDATA1 Setup Time to RMII_REFCLK Rising	5	-	-	ns	-
$T_{HD_RMII_RX}$	RMII_CRSDV, RMII_RXDATA0 and RMII_RXDATA1 Hold Time from RMII_REFCLK Rising	2	-	-	ns	-

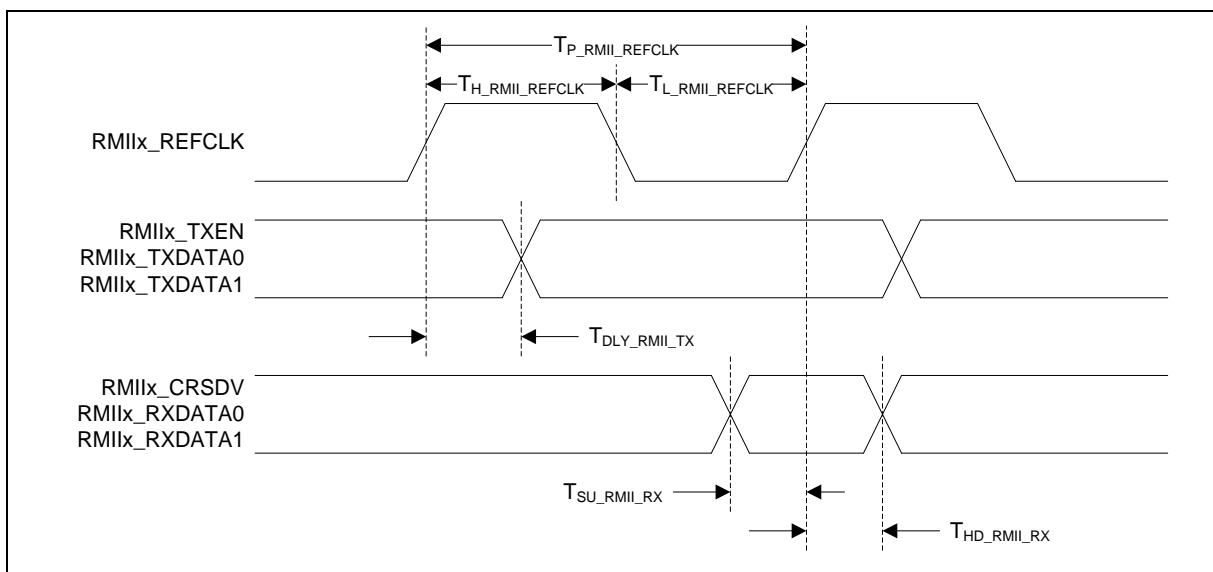

Figure 8.13-1 RMII Interface Timing Diagram

8.13.2 Ethernet PHY Management Interface Timing

Symbol	Parameter	Min	Typ	Max	Unit	Test Condition
$T_{P_RMII_MDC}$	RMII_MDC Period	400	-	-	ns	-
$T_{H_RMII_MDC}$	RMII_MDC High Time	200	-	-	ns	-
$T_{L_RMII_MDC}$	RMII_MDC Low Time	200	-	-	ns	-
$T_{DLY_RMII_MDIOWR}$	RMII_MDC Falling to Valid RMII_MDIO Delay	-	-	10	ns	-

$T_{SU_RMII_MDIORD}$	RMII_MDIO Setup Time to RMII_MDC Rising	10	-	-	ns	-
$T_{HD_RMII_MDIORD}$	RMII_MDIO Hold Time from RMII_MDC Rising	10	-	-	ns	-

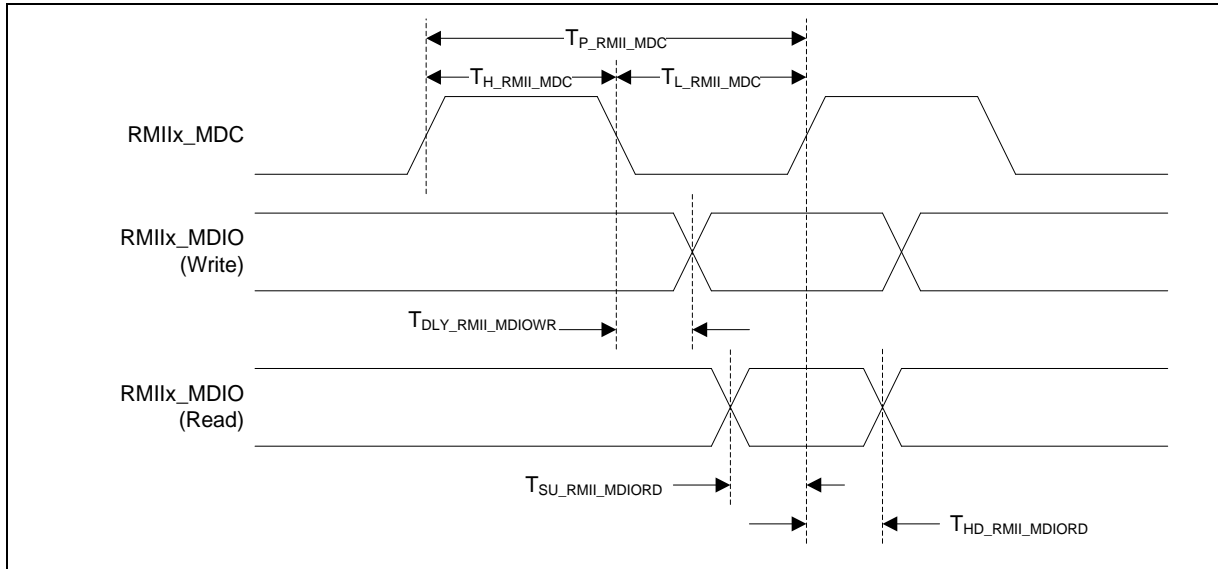

Figure 8.13-2 Ethernet PHY Management Interface Timing Diagram

8.14 SDIO Characteristics

8.14.1 Default Mode Timing

在嗎	Parameter	Min	Typ	Max	Unit	Test Condition
$T_{P_SD_CLK}$	SD_CLK Period (Data Transfer Mode)	40	-	-	ns	-
$T_{P_SD_CLK_ID}$	SD_CLK Period (Identification Mode)	2,500	-	-	ns	-
$T_{H_SD_CLK}$	SD_CLK High Time	-	20	-	ns	-
$T_{L_SD_CLK}$	SD_CLK Low Time	-	20	-	ns	-
$T_{SU_SD_IN}$	SD_DATA Setup Time to SD_CLK Rising	5	-	-	ns	-
$T_{HD_SD_IN}$	SD_DATA Hold Time from SD_CLK Rising	5	-	-	ns	-
$T_{DLY_SD_OUT}$	SD_CLK Falling to Valid SD_DATA Delay	-	-	14	ns	-

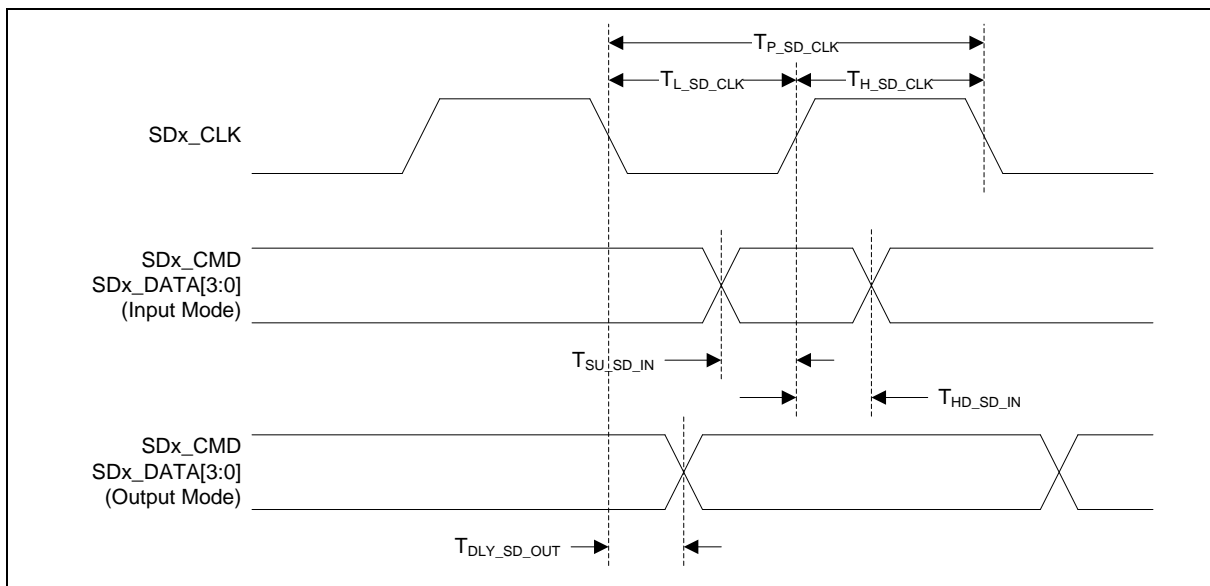

Figure 8.14-1 SDIO Default Mode

8.14.2 SDIO Dynamic characteristics

Symbol	Parameter	Min	Typ	Max	Unit	Test Condition
$T_{P_SD_CLK}$	SD_CLK Period	20	-	-	ns	-
$T_{H_SD_CLK}$	SD_CLK High Time	7	-	-	ns	-
$T_{L_SD_CLK}$	SD_CLK Low Time	7	-	-	ns	-

$T_{SU_SD_IN}$	SD_DATA Setup Time to SD_CLK Rising	6	-	-	ns	-
$T_{HD_SD_IN}$	SD_DATA Hold Time from SD_CLK Rising	2	-	-	ns	-
$T_{DLY_SD_OUT}$	SD_CLK Falling to Valid SD_DATA Delay	-	-	14	ns	-
$T_{HD_SD_OUT}$	SD_DATA Hold Time from SD_CLK Rising	2.5	-	-	ns	-

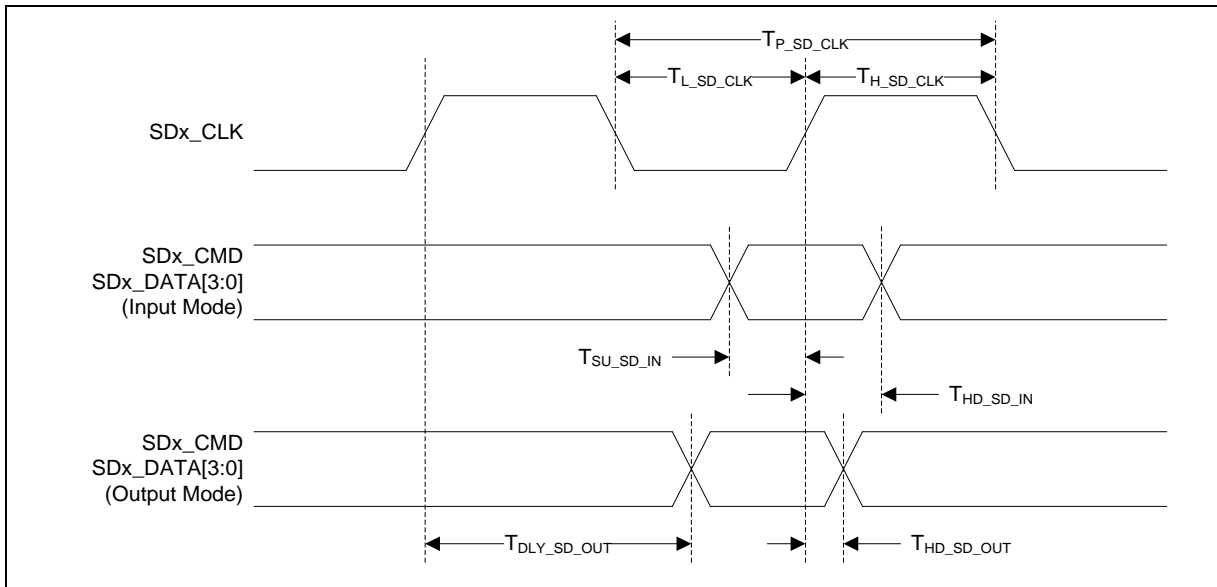
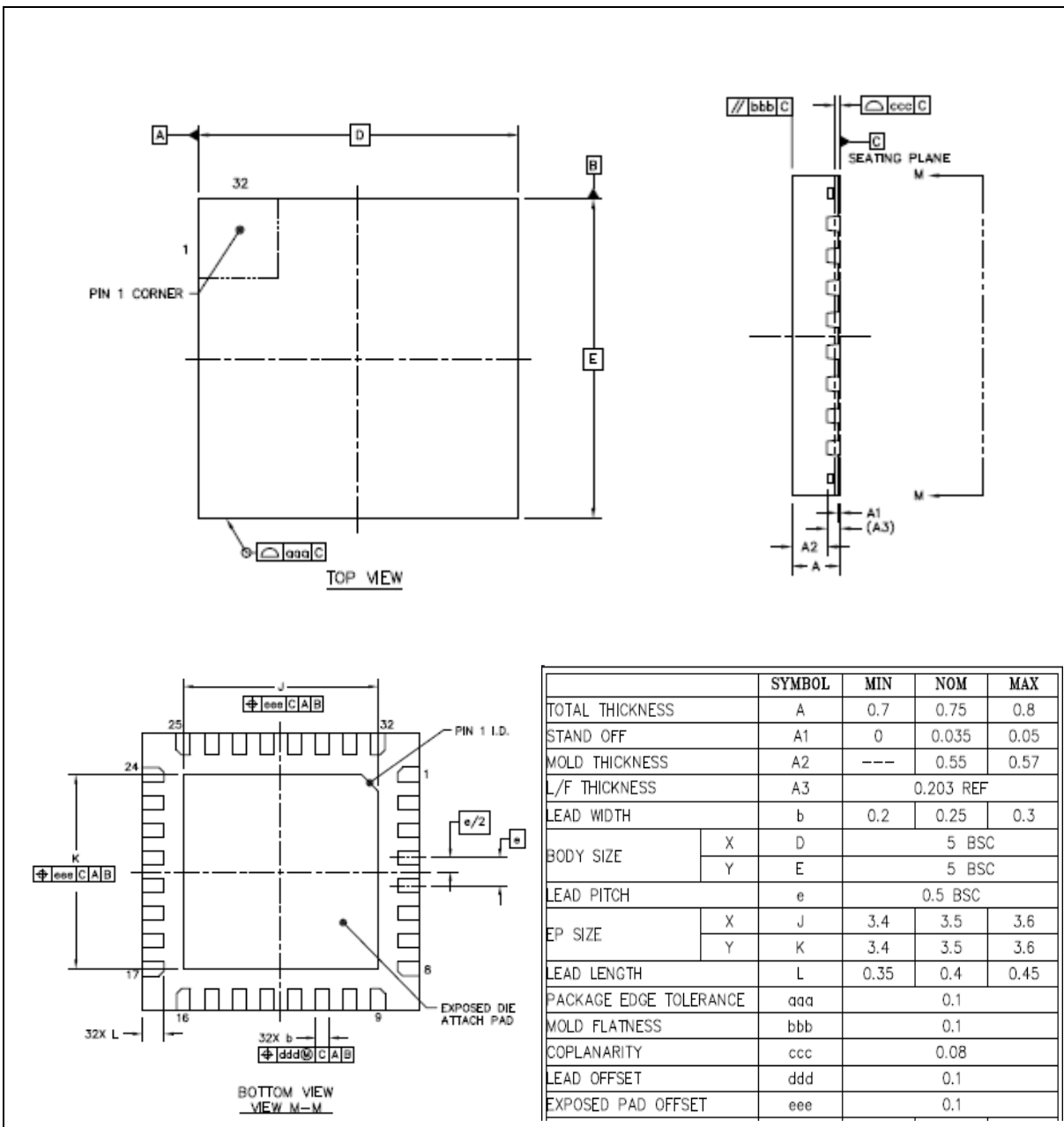

Figure 8.14-2 SDIO High-speed Mode

9 PACKAGE OUTLINE DRAWING

9.1 QFN 33L (5x5x0.8 mm³ Pitch 0.5 mm)



9.2 LQFP 48L (7x7x1.4 mm³ Footprint 2.0mm)

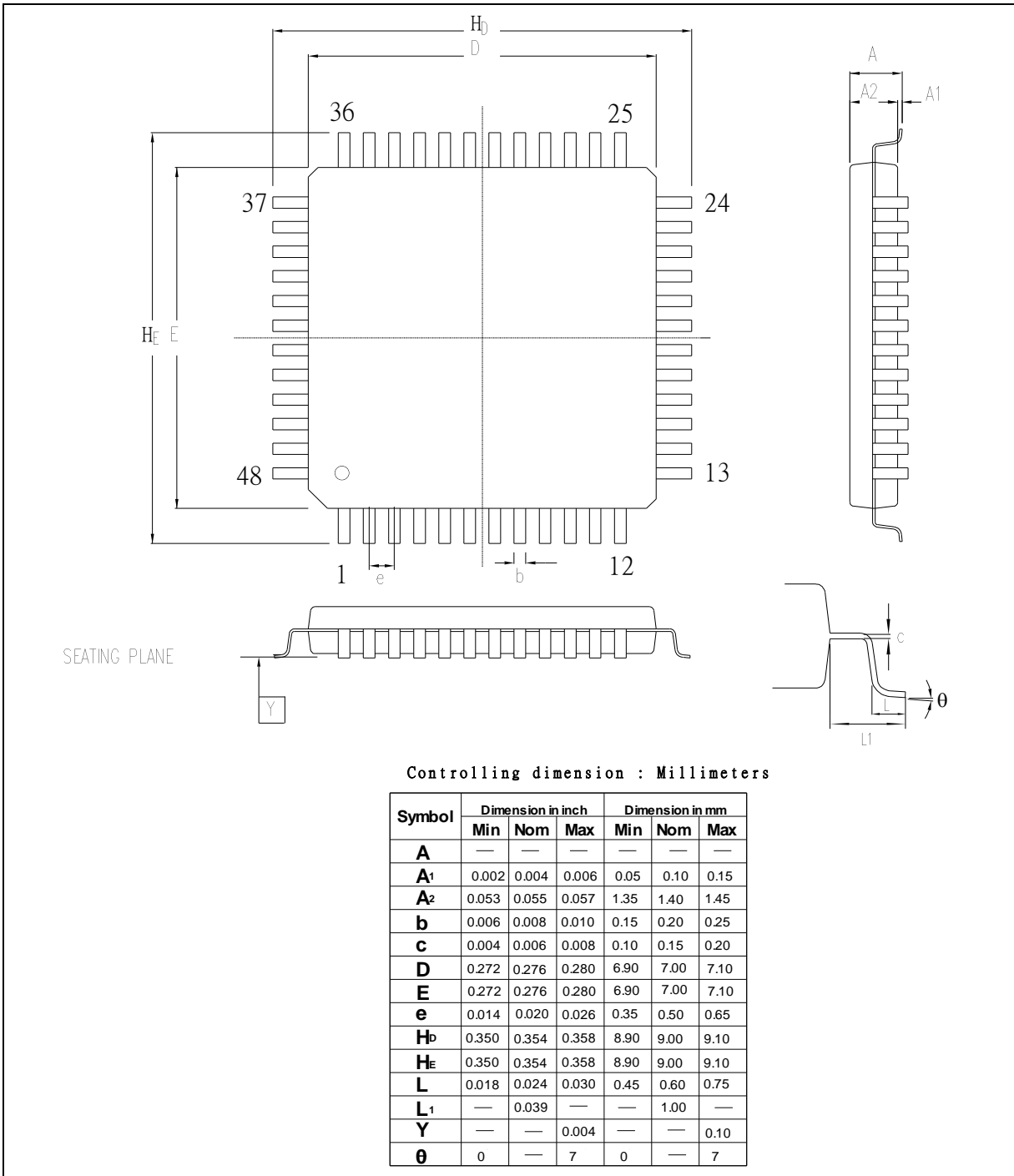

9.3 LQFP 64L (7x7x1.4 mm³ footprint 2.0 mm)

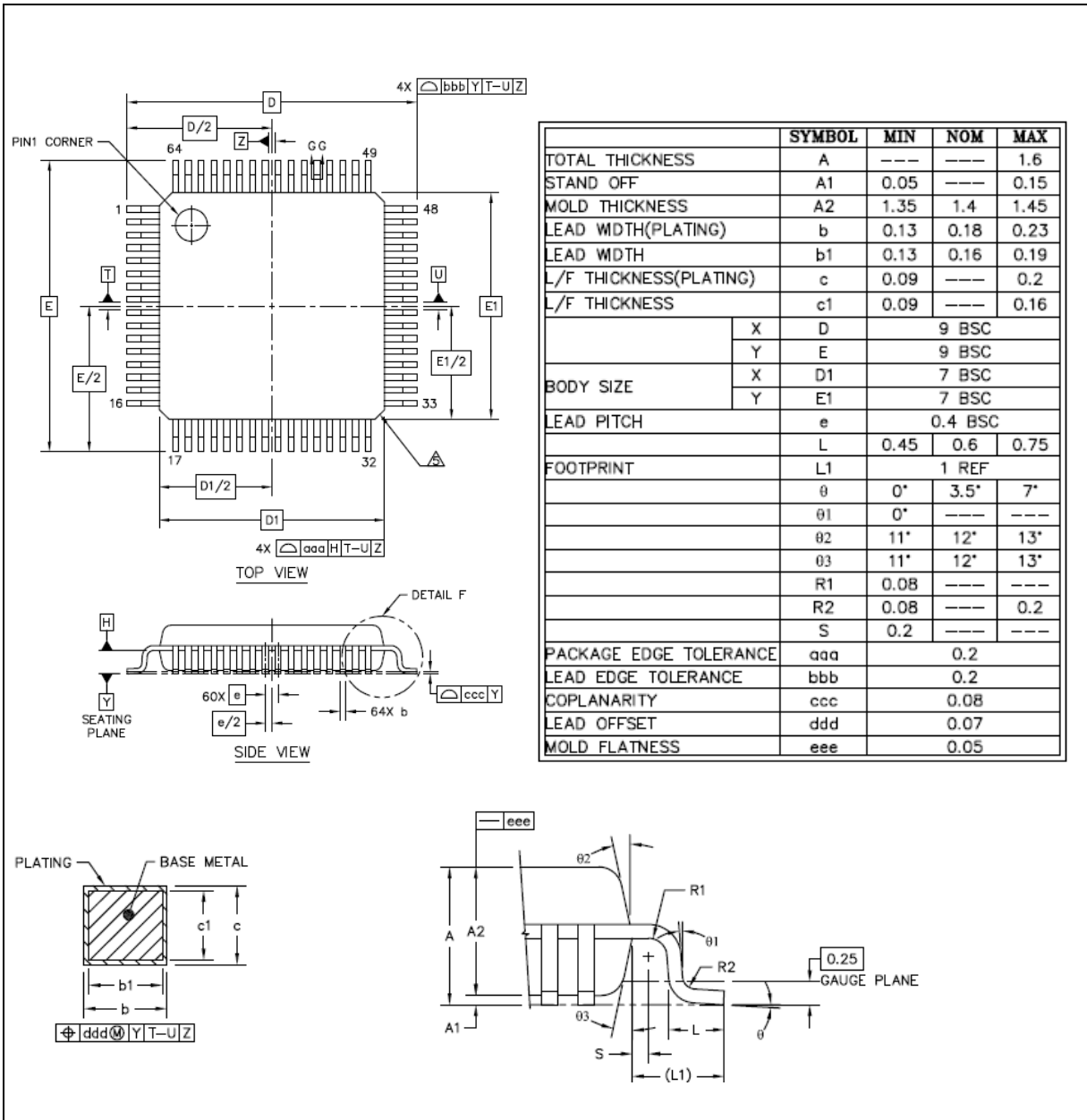

9.4 LQFP 128L (14x14x1.4 mm³ footprint 2.0 mm)

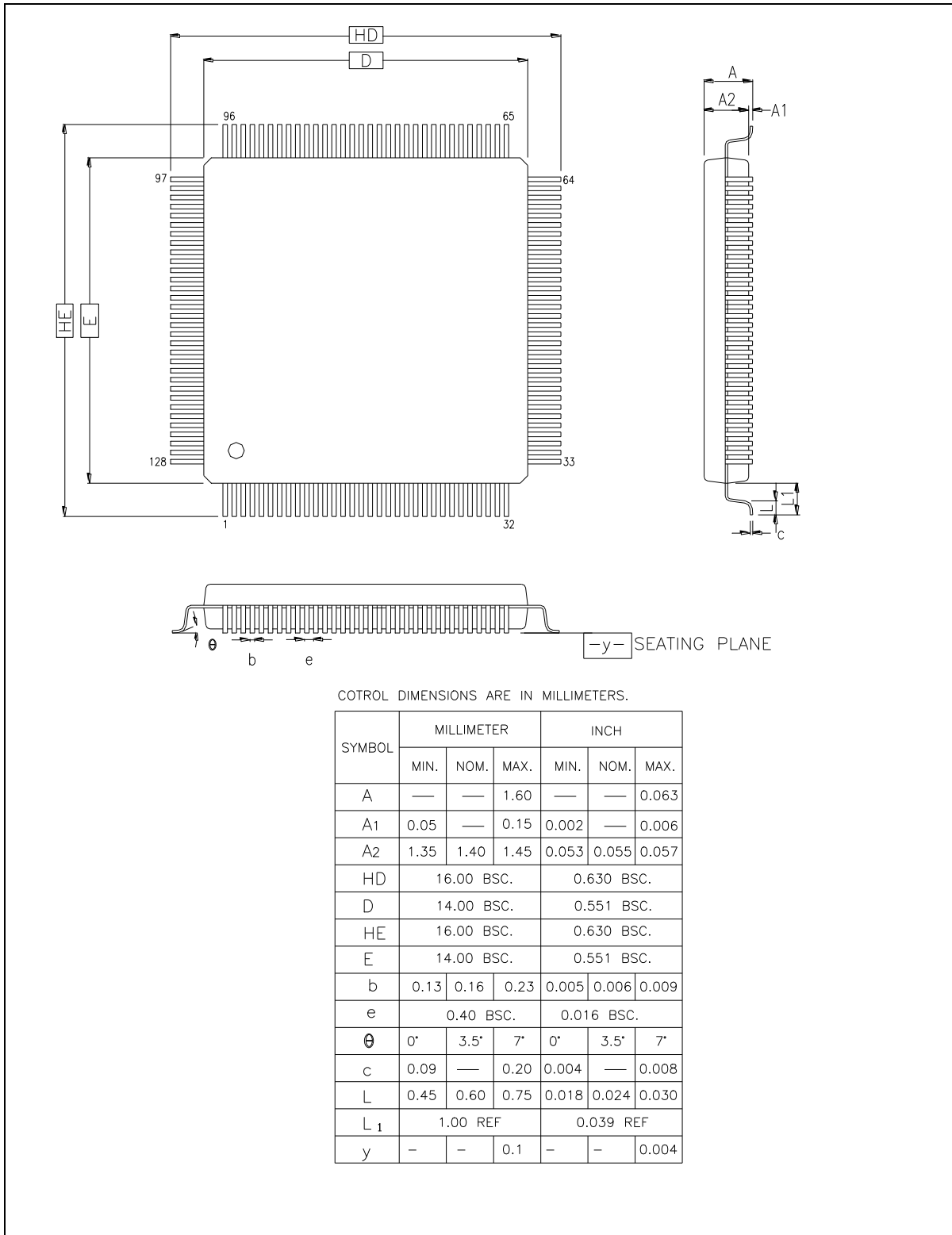

9.5 LQFP 144L (20x20x1.4 mm³ footprint 2.0 mm)

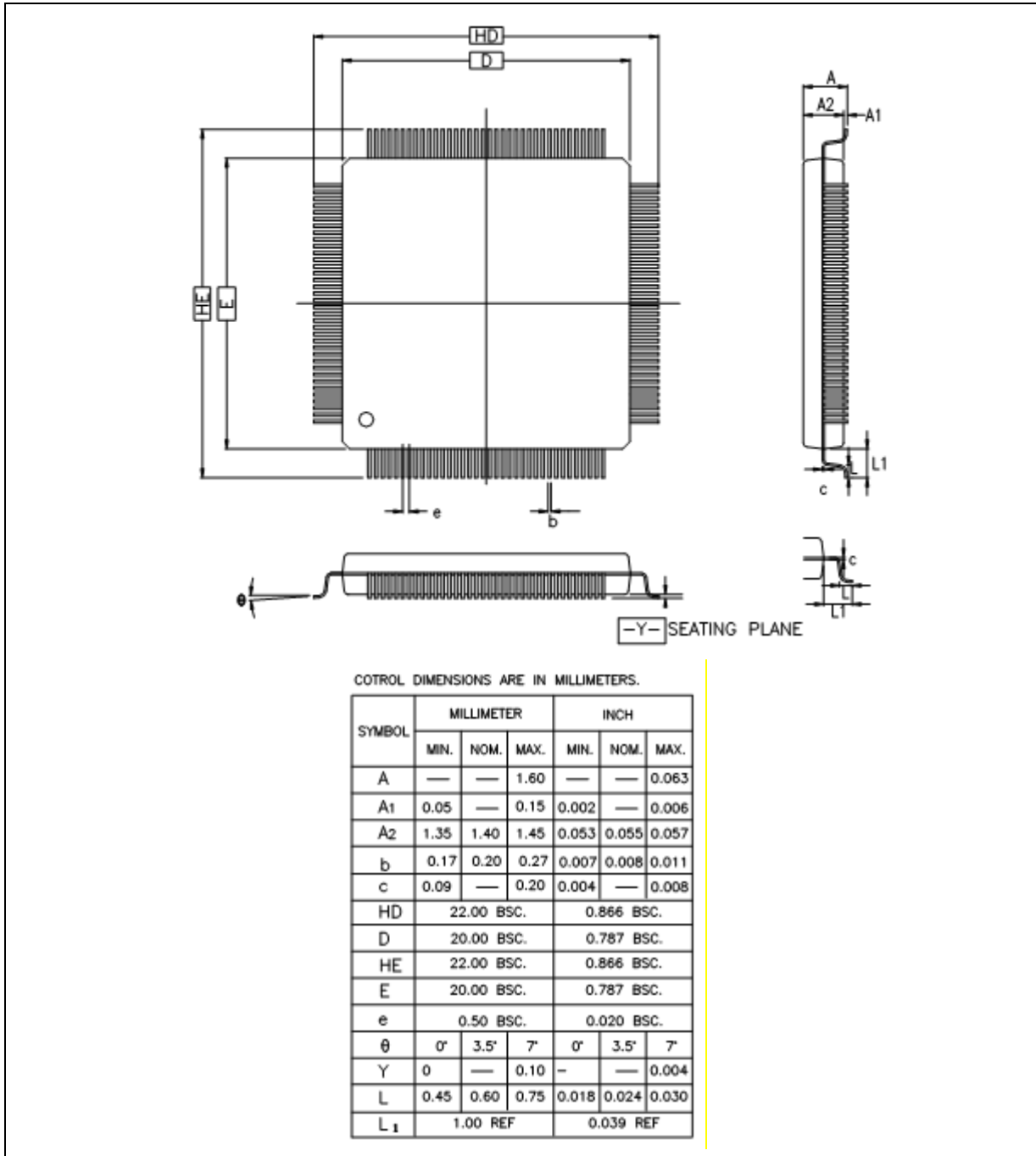

10 ABBREVIATION

10.1 Abbreviations

Acronym	Description
ACMP	Analog Comparator Controller
ADC	Analog-to-Digital Converter
AES	Advanced Encryption Standard
APB	Advanced Peripheral Bus
AHB	Advanced High-Performance Bus
BOD	Brown-out Detection
CAN	Controller Area Network
DAP	Debug Access Port
DES	Data Encryption Standard
EADC	Enhanced Analog-to-Digital Converter
EBI	External Bus Interface
EMAC	Ethernet MAC Controller
EPWM	Enhanced Pulse Width Modulation
FIFO	First In, First Out
FMC	Flash Memory Controller
FPU	Floating-point Unit
GPIO	General-Purpose Input/Output
HCLK	The Clock of Advanced High-Performance Bus
HIRC	12 MHz Internal High Speed RC Oscillator
HXT	4~24 MHz External High Speed Crystal Oscillator
IAP	In Application Programming
ICP	In Circuit Programming
ISP	In System Programming
LDO	Low Dropout Regulator
LIN	Local Interconnect Network
LIRC	10 kHz internal low speed RC oscillator (LIRC)
MPU	Memory Protection Unit
NVIC	Nested Vectored Interrupt Controller
PCLK	The Clock of Advanced Peripheral Bus
PDMA	Peripheral Direct Memory Access
PLL	Phase-Locked Loop
PWM	Pulse Width Modulation

QEI	Quadrature Encoder Interface
SD	Secure Digital
SPI	Serial Peripheral Interface
SPS	Samples per Second
TDES	Triple Data Encryption Standard
TK	Touch Key
TMR	Timer Controller
UART	Universal Asynchronous Receiver/Transmitter
UCID	Unique Customer ID
USB	Universal Serial Bus
WDT	Watchdog Timer
WWDT	Window Watchdog Timer

Table 10.1-1 List of Abbreviations

11 REVISION HISTORY

Date	Revision	Description
2018.03.30	1.00	Initial version.

Important Notice

Nuvoton Products are neither intended nor warranted for usage in systems or equipment, any malfunction or failure of which may cause loss of human life, bodily injury or severe property damage. Such applications are deemed, "Insecure Usage".

Insecure usage includes, but is not limited to: equipment for surgical implementation, atomic energy control instruments, airplane or spaceship instruments, the control or operation of dynamic, brake or safety systems designed for vehicular use, traffic signal instruments, all types of safety devices, and other applications intended to support or sustain life.

All Insecure Usage shall be made at customer's risk, and in the event that third parties lay claims to Nuvoton as a result of customer's Insecure Usage, customer shall indemnify the damages and liabilities thus incurred by Nuvoton.

*Please note that all data and specifications are subject to change without notice.
All the trademarks of products and companies mentioned in this datasheet belong to their respective owners.*

X-ON Electronics

Largest Supplier of Electrical and Electronic Components

Click to view similar products for [32-bit Microcontrollers - MCU category](#):

Click to view products by [Nuvoton manufacturer](#):

Other Similar products are found below :

[MCF51AC256AVFUE](#) [MCF51AC256BCFUE](#) [MCF51AC256BVFUE](#) [MB91F464AAPMC-GSE2](#) [R5S726B0D216FP#V0](#) [MB91F248PFV-GE1](#) [MB91243PFV-GS-136E1](#) [SAK-TC1782F-320F180HR BA](#) [TC364DP64F300WAAKXUMA1](#) [R5F566NNDDFP#30](#)
[R5F566NNDDFC#30](#) [R5F566NNDDBD#20](#) [MC96F8216ADBN](#) [A96G181HDN](#) [A96G140KNN](#) [A96G174FDN](#) [A31G213CL2N](#)
[A96G148KNN](#) [A96G174AEN](#) [AC33M3064TLBN-01](#) [V3s](#) [T3](#) [A40i-H](#) [V526](#) [A83T](#) [R11](#) [V851s](#) [A133](#) [V833](#) [F1C100S](#) [T3L](#) [T507](#) [A33](#)
[A63](#) [T113-i](#) [H616](#) [V853](#) [V533](#) [R16-J](#) [V536-H](#) [A64-H](#) [V831](#) [V3LP](#) [T113-S3](#) [F1C200S](#) [F133-A](#) [R128-S2](#) [D1-H](#) [ADUCM360BCPZ128-TR](#)
[APT32S003F8PT](#)