



GPS/GLONASS/GALILEO/SBAS RECEIVERS

NV08C-CSM v.3.x, v.4.x

Datasheet

Version 2.6



NVS Technologies AG

Letzastrasse 2, 9462 Montlingen Switzerland

Tel +41 71 760 07 36 Fax +41 71 760 07 38

www.nvs-gnss.com

Revision History

Revision ID	Date	Description
1.0	November 1, 2010	First version for distribution
1.1	December 27, 2010	General editing
2.3	January 17, 2012	General editing
2.4	March 12, 2012	General editing
2.5	January 22, 2014	General editing for HW release 4.1
2.6	February 18, 2014	Chapter Packaging information added

Contents

Revision History.....	2
Contents	3
1. Overview	4
1.1. Introduction.....	4
1.2. Navigation Features.....	5
1.3. RF Functionalities	6
1.4. Environmental Data.....	6
1.5. Data Interfaces	6
1.6. Electrical Parameters.....	7
2. Hardware Reference	8
2.1. Package.....	8
2.2. Signals Specification	8
2.3. Electrical Specification.....	10
2.3.1. Absolute Maximum Ratings.....	10
2.3.2. Recommended Operating Conditions	10
2.3.3. Power Consumption	12
2.4. Hardware Integration Guide.....	13
2.4.1. Power Supply	13
2.4.2. Reset	16
2.4.3. 1PPS Output.....	16
2.4.4. Active Antenna connection	16
2.4.5. Digital IO Interfaces	18
2.4.6. Backup Power Supply VBAT.....	19
3. Software and Protocols Reference.....	20
3.1. Data Protocol and Configuration.....	20
3.2. Low Power Battery Mode.....	20
3.3. Sleep Mode.....	20
3.4. Assisted GNSS	21
3.5. FW update	21
3.6. Dead Reckoning Option.....	22
Appendix 1. NV08C-CSM Outline drawing and Footprint	23
Appendix 2. NV08C-CSM Recommended Solder Reflow Profile	26
Appendix 3. Packaging Information	27

1. Overview

1.1. Introduction

The NV08C-CSM is a fully integrated multi-constellation satellite navigation receiver. The NV08C-CSM's key feature is its full compatibility with GPS, GLONASS and future global navigation satellite systems (GNSS) GALILEO, as well as Satellite Based Augmentation Systems (SBAS), EGNOS, WAAS and MSAS. The NV08C-CSM device is specifically designed for use in LBS and M2M applications, demanding low cost, low power consumption, small form factor and uncompromised performance.

Applications:

- Fleet management/Telematics and anti-theft systems
- In-car and personal navigation devices
- Asset and personal tracking
- Surveillance and security systems
- LTE, WiMAX, Wi-Fi & cellular base station time synchronization

The NV08C-CSM offers high sensitivity and high performance acquisition and tracking, low power consumption and assisted GPS/GLONASS/GALILEO (A-GNSS) functionality. Tracking satellites from multiple GNSS constellations ensures much higher availability of navigation signals when compared to single constellation alternatives, providing increased performance, accuracy and reliability to devices used in urban and industrial environments. It features two RF channels (GPS and GLONASS) and 3-stage filtration for better noise immunity. As well, a variety of interfaces, flexible power supply options, and a supply voltage for an active antenna are provided. This very compact and fully featured GNSS receiver can be integrated on a low cost 2 or 4 layer PCB with minimum additional passive components.

Evaluations Tools:

An evaluation/development kit (NV08C-EVK-CSM) is available to help developers quickly familiarise themselves with the NV08C-CSM's features and functionalities. It is a flexible tool that allows users to evaluate the NV08C-CSM's various modes of operation, as well as to override default configurations/settings and interfaces.

The NV08C-EVK-CSM can be used with navigation systems to obtain current position (latitude, longitude and elevation), velocity and time, utilising all available Global Navigation Satellite Systems (GNSS), including GPS, GLONASS, GALILEO and SBAS signals, at any location on earth and at any time.

Please visit <http://nvs-gnss.com/products/evk/item/4-evk-csm.html> for additional information.

Block diagram in **Fig. 1.** describes main internal blocks and interfaces of NV08C-CSM module.

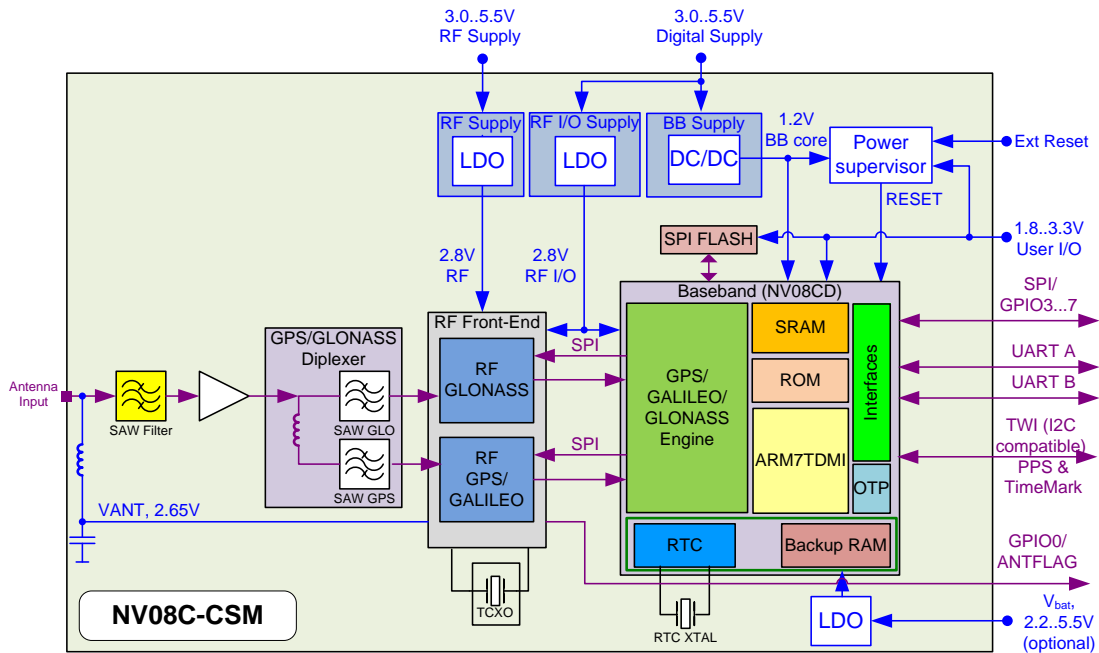

Fig. 1. NV08C-CSM Block Diagram

1.2. Navigation Features

Parameter	Description
Supported GNSS signals	L1 GPS/SBAS C/A L1 GLONASS CT L1 GALILEO OS Data+Pilot
Number of channels	32 channels each capable to receive any supported signal
Time to first fix	Cold star: 25 s (average) Warm start: 25 s (average) Hot start: 3 s (average)
Sensitivity	Cold star: -143 dBm With A-GNSS: -160 dBm Tracking mode: -160 dBm
Accuracy ¹	Autonomous mode: <1.5 m Differential mode SBAS: <1 m Differential mode DGNSS: <1 m Height: <2 m Velocity: 0.05 m/s
Assisted GNSS	Supported
1PPS time accuracy	15 ns accuracy (rms), 38.5ns granularity (1/26 MHz)
Update rate	Up to 10Hz
Limitations	Velocity: less than 500 m/s Acceleration: less than 5 g Height: less than 50,000 m

¹ RMS, 24hr static, SV @ -135 dBm

1.3. RF Functionalities

The NV08C-CSM requires an active antenna to be connected to the RF input. The 2.65V active antenna supply voltage is available at the RF input as soon as an active antenna is connected and a current flow is present (if $I_{ANTBIAS} > 1.1\text{mA}$). If the antenna current draw exceeds 57 mA, short circuit protection will automatically block the supply voltage to the RF input pin.

Note – An external voltage source can be used to power the active antenna, however the short-circuit protection will not operate.

The NV08C-CSM features a two-stage RF-filter circuit that provides high out-of-band interference immunity. A front-end wideband GPS+GLONASS RF filter ensures more than 40dB suppression of far-field interference, from sources such as GSM, WiFi, WiMAX, LTE and Bluetooth signal transmitters. The second filter stage is located at the output of the GPS/GLONASS Diplexer on two separate RF channels, ensuring high channel separation and additional out-of-band interference attenuation.

The parameters of the NV08C-CSM's RF inputs are as shown in **Table 1**.

Table 1. RF Input Parameters

Active Antenna	
1dB Compression Point	+30 dBm
Input Return Loss	-15 dB
Total Noise Figure of the analogue path at the RF input	6 dB

Note – **Table 1** shows estimated values. The actual values may differ as a result of device qualification.

The GPS/GLONASS Diplexer's output signals are further processed by two independent analogue ICs on two separate receiver channels:

- GPS/GALILEO/SBAS L1 (1575.42 MHz @ 4 MHz)
- GLONASS L1 (1601.5 MHz @ 8 MHz)

On both channels the satellite signals are first down-converted to the IF band (at approximately 4 to 5 MHz), then filtered by Polyphase Filters. The GPS channel filter has a bandwidth of 4 MHz, and the GLONASS channel has a bandwidth of 8 MHz. The signals then pass through a Variable Gain Amplifier with Automatic Gain Control. The analogue ICs include 2-bit ADCs that convert the signals from analogue to digital to be processed by the digital baseband IC.

Typically both input channels are enabled to simultaneously receive all available navigation signals. However to save power, one of two channels may be disabled via software ("GPS Only" mode).

In order to facilitate fast acquisition of low level signals in poor reception areas, the NV08C-CSM contains a 26 MHz frequency generator (TCXO) with high temperature stability (± 0.5 ppm).

1.4. Environmental Data

Operating temperature: -40°C to +85°C

Maximum relative humidity: 98% at +40°C

1.5. Data Interfaces

Host data interface:

- Two UART (4,800 to 230,400 bit/s)
- 1PPS output/external synchronization pulse (input)
- 8 GPIO
- One SPI*
- One TWI (I²C compatible)*

* requires a non-standard firmware load

Supported protocols:

- IEC61162-1 (NMEA 0183)
- BINR (proprietary)
- RTCM v.2.x (messages #1, #31)

Data update/output rate: 1, 2, 5, 10 Hz

1.6. Electrical Parameters

The NV08C-CSM device requires the following power supply voltages:

Digital I/O supply	1.8 to 3.3 V
Digital and RF supply	3.0 to 5.5 V
Backup memory and RTC clock	2.2 to 5.5 V

The maximum power consumption is as follows:

Continuous tracking mode:

- GPS only 120 mW*
- GNSS 180 mW*

Sleep mode:

- 100 μ A* (All power supplies must be provided)

Backup mode:

- 4 μ A @ 2.2 to 5.5 V (only RTC and Backup RAM supply)

* average value.

The Sleep Mode allows minimizing power consumption of NV08C device without turning off of all power supplies. NV08C devices are sleeping in thin mode (no signal tracking and navigation supported). Refer to chapter **3.3. Sleep Mode** for additional details.

The Backup Mode is supported by an on-chip real-time clock and static RAM, in order to safe-keep true time and other parameters, while the main power is turned off. This feature allows the receiver's start-up time (prior to receiving first valid navigation data) to be much shorter. To use the Backup Mode backup voltage must be provided to the VBAT pin (see chapters below).

2. Hardware Reference

2.1. Package

NV08C-CSM features a LGA like package. SMD components are mounted on the one side (top side) of its PCB and shielded by a metal cover to protect against mechanical damage and electromagnetic interference. The other side (bottom side) of the NV08C-CSM is equipped with 35 pads for SMT assembly on customer's PCB (plus test pads used exclusively in NV08C-CSM production).

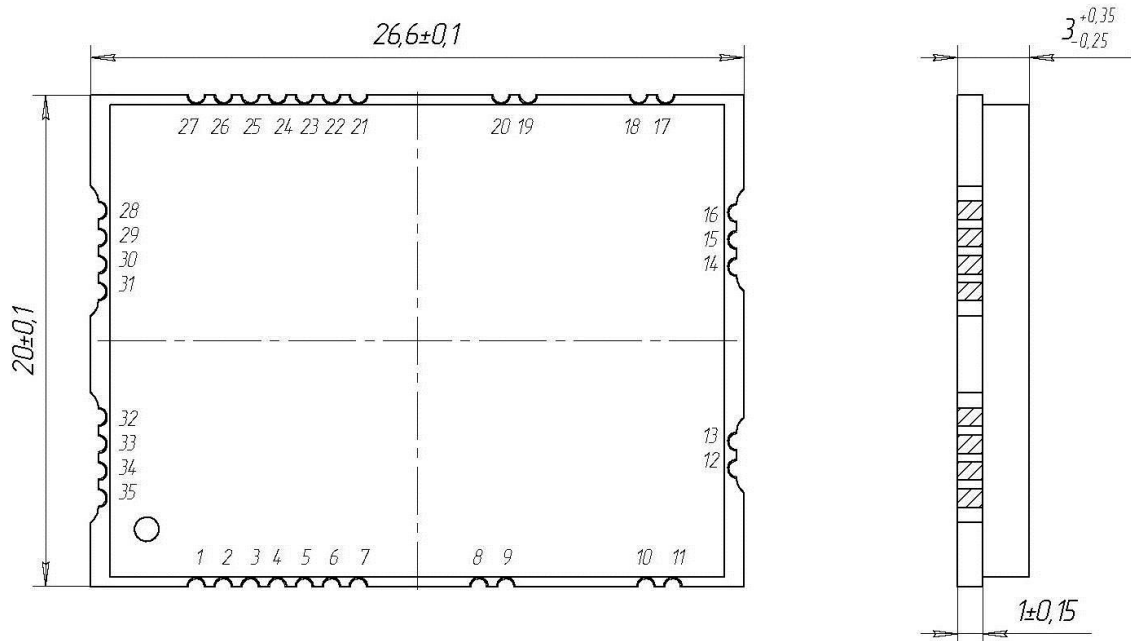

Fig. 2. Drawing and dimensions of the NV08C-CSM module (mm). Top view.

Detailed package drawing is shown in **Appendix 1**. NV08C-CSM Outline drawing and Footprint

Note – Test pads located on the bottom side of the module must remain unconnected on user's PCB.

2.2. Signals Specification

Table 2 provides NV08C-CSM's pin signal type abbreviations and definitions. **Table 3** provides NV08C-CSM's list of pins, along with their signal name, pin number, pin type and description.

Table 2. Signal Type Definitions

Pin Type	Definition
I	Input Only
O	Output Only
I/O	Input or Output
AN	Analogue
PWR	Power
GND	Ground

Table 3. List of Pins

Pin Number	Pin Name	Pin Type	Description
Programmable I/O signals			
1	GPIO2	I/O	RESERVED, [TimeMark* (external sync pulse), GPIO*, TWI clock*]
2	GPIO1	I/O	1PPS output [TWI data*, GPIO*]
4	GPIO5	I/O	Configuration pin [SPI A data MOSI* output (master)/ input (slave), GPIO*]
5	GPIO7	I/O	Configuration pin [SPI A Clock*, GPIO*]
6	GPIO3	I/O	Configuration pin [SPI A CS1*, GPIO*]
7	GPIO4	I/O	Configuration pin [SPI A data MISO* output (slave)/ input (master), GPIO*]
20	GPIO0	O	ANT FLAG, external active antenna flag (output): 1 – active antenna current draw detected 0 – no current Operates only if active antenna is powered by the External active antenna pin (pin 15)
35	GPIO6	I/O	Configuration pin [GPIO*]
Interface pins			
30	RX2	I	Input UART B
31	TX2	O	Output UART B
32	TX1	O	Output UART A
33	RX1	I	Input UART A
Power Supply and GND pins			
8	VIN_A	PWR I	Power supply for RF chain (LDO A)
21	SLEEP_FLAG	O	Low power consumption mode flag. 1 – normal device operation 0 – sleep mode (low power consumption mode)
23	VBAT	PWR I	BB battery supply
26	VIN_D	PWR I	Power supply for digital chain (LDO D)
28	VCCIO	PWR I	Power supply for IO's
Reset signal			
25	#RES	I	Reset input/active level is low
RF input signals			
15	RF	AN I	External active antenna pin. 2.65 to 2.8V power supply
GND pins			
3, 9, 10, 11, 12, 13, 14, 16, 17, 18, 19, 22, 24, 27, 29, 34	GND	GND	Ground

* These GPIO pin settings can be re-allocated by FW Patch (see 3.5. FW update).

2.3. Electrical Specification

2.3.1. Absolute Maximum Ratings

Table 4 provides NV08C-CSM's absolute maximum (stress) ratings. Operation at or beyond these maximum ratings might cause permanent damage to the device.

Table 4. Absolute Maximum Ratings

Symbol	Parameter	Minimum	Maximum	Unit
T _s	Storage Ambient Temperature	-55	125	°C
VIN_A	Supply Voltage for RF chain (LDO A)	-0.3	6	V
VIN_D	Supply Voltage for digital chain (LDO D)	-0.3	6	V
VCCIO	Baseband IO Supply Voltage	-0.5	4.6	V
VBAT	Baseband Battery Supply Voltage	-0.3	6	V
PRF	RF_IN Signal Power		10	dBm
VIO	GPIO7 – GPIO0, #RES (RESET) Voltage	-0.5	VCCIO +0.5 (<4.6)	V

2.3.2. Recommended Operating Conditions

Recommended operating conditions guarantee correct device operation.

As long as the device is used within these ranges, electrical DC and AC characteristics are guaranteed.

2.3.2.1. Ambient Temperature

Table 5. Operating Ambient Temperature

Symbol	Parameter	Minimum	Maximum	Unit
T _A	Operating Ambient Temperature	-40	+85	°C

2.3.2.2. Power Supply Voltage

Table 6. Power Supply Voltage

Symbol	Parameter	Minimum	Typical	Maximum	Unit
VIN_A	Supply Voltage for RF chain (LDO A)	3.0	3.3	5.5	V
VIN_D	Supply Voltage for digital chain (LDO D)	3.0	3.3	5.5	V
VCCIO	Baseband IO Supply Voltage	1.65	1.8/2.5/3.3	3.6	V
VBAT	Baseband Battery Supply Voltage	2.2	3.3	5.5	V

Table 7. Antenna Power Supply

Symbol	Parameter	Minimum	Typical	Maximum	Unit
V_ANT	Voltage active antenna	2.5	2.65	2.8	V
I_ANT	Current consumption of active antenna	1.1 ¹		57 ²	mA

¹ Minimum current for the built-in active antenna detector

² Maximum active antenna current

2.3.2.3. Input Voltage

Table 8. Input Voltage for GPIO7 – GPIO0

Symbol	Parameter	IO Power Supply Voltage VCC_BBIO	Minimum	Maximum	Unit
V _{IH}	High Level Input Voltage	3.3V	2.0	VCCIO + 0.3	V
		2.5V	1.7	VCCIO + 0.3	V
		1.8V	0.65 x VCC_BBIO	VCCIO + 0.3	V
V _{IL}	Low Level Input Voltage	3.3V	-0.3	0.8	V
		2.5V	-0.3	0.7	V
		1.8V	-0.3	0.35 x VCCIO	V

Table 9. Input Voltage for #RES (RESET)

Symbol	Parameter	IO Power Supply Voltage VCC_BBIO	Minimum	Maximum	Unit
V _{IH}	High Level Input Voltage	3.3V	2.1	VCCIO + 0.3	V
		2.5V	1.7	VCCIO + 0.3	
		1.8V	0.7 x VCCIO	VCCIO + 0.3	
		1.2V	0.7 x VCCIO	VCCIO + 0.3	
V _{IL}	Low Level Input Voltage	3.3V	-0.3	0.7	V
		2.5V	-0.3	0.7	
		1.8V	-0.3	0.3 x VCCIO	
		1.2V	-0.3	0.3 x VCCIO	

The NV08C-CSM's inputs and outputs are either pulled-up or pulled-down (internally) as described in **Table 10**. Refer to **Table 11** for resistor values (BB I/O cells).

Table 10. I/O State after RESET

I/O	Pull UP/ Pull Down after RESET
GPIO7	PU
GPIO6	PU
GPIO5	PD
GPIO4	PD
GPIO3	PD
GPIO2	PU
GPIO1	PU
GPIO0	PU
UARTA TX	PU
UARTA RX	PD
UARTB TX	PU
UARTB RX	PD

Table 11. Pull-up and Pull-down Resistors

I/O cell resistor	Supply voltage	Min	Nominal	Max
Pull-Up resistor, kOhm	VCCIO = 3.3V	28	43	86
	VCCIO = 2.5V	37	58	99
	VCCIO = 1.8V	53	97	175
Pull-Down resistor, kOhm	VCCIO = 3.3V	25	41	95
	VCCIO = 2.5V	33	59	113
	VCCIO = 1.8V	52	107	212

2.3.2.4. DC Characteristics

Table 12. DC Characteristics

Symbol	Parameter	IO Power Supply Voltage VCC_BBIO	Conditions	Minimum	Maximum	Unit
V _{OH}	High Level Output Voltage	3.3V	IOH = -100uA	VCCIO -0.2	-	V
			IOH = -4mA	VCCIO -0.4	-	
		2.5V	IOH = -100uA	VCCIO -0.2	-	
			IOH = -4mA	VCCIO -0.45	-	
		1.8V	IOH = -100uA	VCCIO -0.2	-	
			IOH = -3mA	VCCIO -0.45	-	
V _{OL}	Low Level Output Voltage	3.3V	IOL = 100uA	-	0.2	V
			IOL = 4mA	-	0.35	
		2.5V	IOL = 100uA	-	0.2	
			IOL = 4mA	-	0.4	
		1.8V	IOL = 100uA	-	0.2	
			IOL = 3mA	-	0.45	
I _L	Input Leak		-	-	±4	uA

2.3.3. Power Consumption

Table 13. Current Consumptions

Symbol	Parameter	Minimum	Typical	Maximum	Unit
IVIN_A	Total supply current through pin VIN_A ¹		20	30	mA
IVIN_D	BB Core Supply Current VIN_D		25	40	mA
IVBAT	BB Battery Supply Current ²			0.1	mA
IVBAT_STBY	BB Battery Supply Standby Current		4		uA
IV_IO	BB IO Supply Current ³			40	mA
IV_IO_STBY	BB IO Supply Standby Current ⁴		20		uA

Notes:

1. Without active antenna current
2. BRAM access rate less than 1M/s
3. Load dependent, maximum current 4mA per digital IO
4. RF portion switched off, module in power saving mode

2.4. Hardware Integration Guide

2.4.1. Power Supply

2.4.1.1. Wiring NV08C-CSM to an External Power Supply

Fig. 3 Provides the NV08C-CSM's power connection diagram

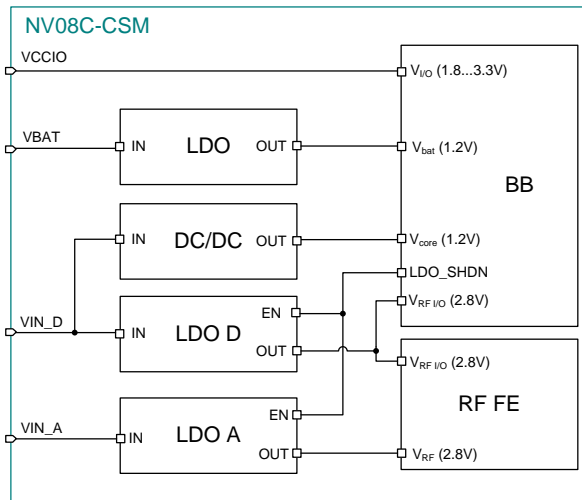

Fig. 3. NV08C-CSM Power Connection Diagram

Four supply inputs for maximum system integration flexibility:

- | | | |
|--|---------------|--------------|
| 1. RF-core power supply (LDO A) | VIN_A, | 3.0 to 5.5 V |
| 2. Digital core power supply (LDO D) | VIN_D, | 3.0 to 5.5 V |
| 3. Backup power supply | VBAT, | 2.2 to 5.5 V |
| 4. I/O power supply | VCCIO, | 1.8 to 3.3 V |

Note – Supply voltages shown above are nominal values. Please refer to Table 6 for maximum upper and lower limits.

The RF front-end is powered by the integrated LDO A and LDO D low-dropout linear regulators. The LDO A provides a clean analogue voltage supply to the RF section, and the LDO D provides a regulated voltage supply to the digital circuitry. The input power supply for the LDO A and LDO D (VIN_A and VIN_D) has a voltage range of 3.0 to 5.5V. The digital baseband (BB) uses three types of voltages: 1.2V as the core voltage (supplied by integrated DC/DC converter), IO voltage (VCCIO, 1.8...3.3V) and a backup supply 1.2V for a Real-Time Clock and backup RAM (supplied by integrated LDO). The Backup power option (VBAT, 2.2...5.5V) must be powered for “hot start” and “warm start” functions. If not required VBAT must be connected to VIN_D.

In User systems power may be provided to the NV08C-CSM in a number of different ways depending on specific design requirements and voltage supply availability. Some of the most common cases are described in the following sections.

2.4.1.2. Single voltage power supply

The external power supply V_IN must be connected to the VIN_A, VIN_D, VCCIO and VBAT pins as follows.

Table 14. External Power Supply Voltage Range

Power Supply	Voltage (V)	
	Min	Max
V_IN	3.0	3.6

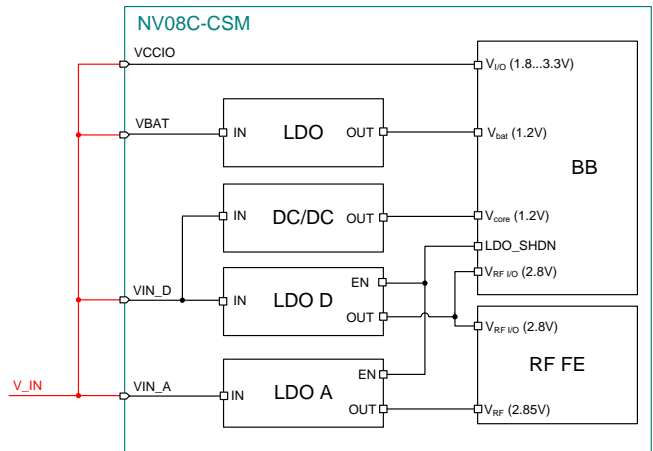

Fig. 4. Power connection to a single voltage power supply

2.4.1.3. External power supply for digital I/Os

Often in User systems, the digital IO signal voltage range differs from the NV08C-CSM's V_IN. To allow for uniform digital IO voltage levels in the NV08C-CSM as in the rest of the User's system, the User system's IO voltage supply must be connected to VCCIO instead of V_IN.

Table 15. External Power Supply Voltage Range

Power Supply	Voltage (V)	
	Min	Max
V_IN	3.0	5.5
V_IO	1.65	3.6

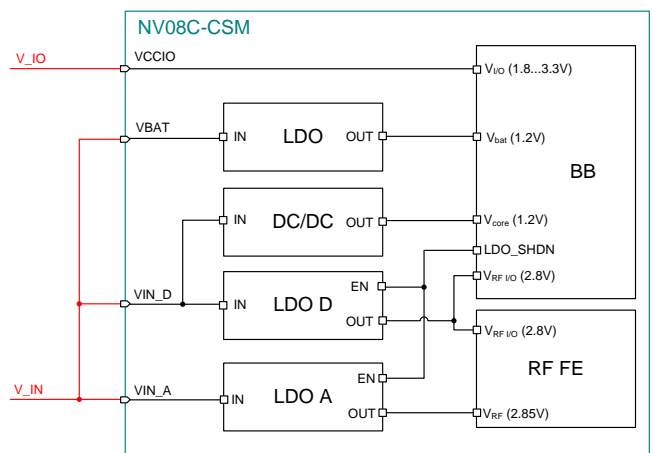

Fig. 5. Power connection to digital I/Os with an external power supply

2.4.1.4. Backup Power Supply

The baseband contains a backup Power Island, which is powered via the pin VBAT. The Power Island contains a Real-Time Clock and backup RAM. If a backup power supply is implemented in the User's system, the VBAT must be powered by the backup supply, so that if the main power supply goes off, the RTC and backup RAM remain powered, hence providing necessary data for faster receiver starts on power-on (warm and hot starts).

Fig. 6 describes the power connections for when the baseband core, backup and IOs supply voltages are provided by the User's system.

Table 16. Voltages of External Power Supply

Power Supply	Voltage (V)	
	Min	Max
V_IN ¹	3.0	3.6
V_IN ²	3.0	5.5
V_IO ²	1.65	3.6
V_BU	2.2	5.5

Notes:

¹ For when VCCIO connected to V_IN.

² For when VCCIO connected to V_IO.

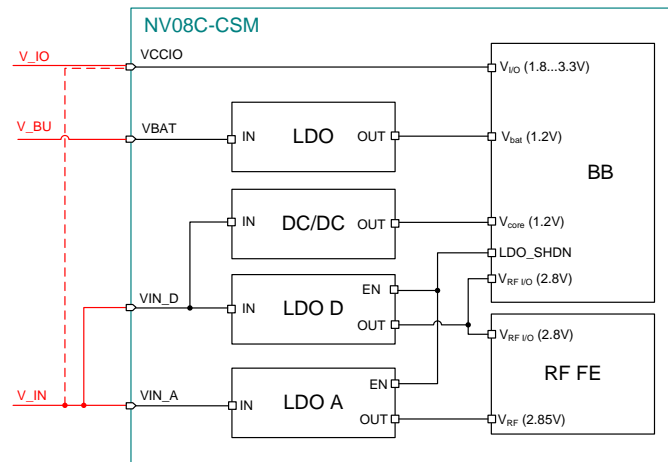

Fig. 6. Power connections to external power supplies for baseband core, IOs and backup

2.4.1.5. Decoupling Capacitors

All necessary decoupling capacitors are integrated in the NV08C-CSM. Nevertheless, in order to minimize the effect of power supply noise on reception of signals it is recommended to;

- Separate power supplies VIN_A and VIN_D either by means of separate power sources or by using inductive isolation.
- Provide an additional capacitor 22pF (0201, NPO or X7R) as close to pin VIN_A as possible.

As an option power supply inputs may be equipped with capacitors as shown in the **Table 17**.

Table 17. Power Supply Capacitors (optional)

Pin	Recommended Capacitors	Note
VIN_A	1 uF ceramic	Optional
VIN_D	1 uF ceramic	Optional
VCCIO	1 uF ceramic	Optional
VBAT	1 uF ceramic	Optional

2.4.1.6. Typical Power Consumption

Table 18 shows average power consumption of the NV08C-CSM in continuous tracking. Power consumption via VCCIO is typically lower than the consumption of the RF, front end and baseband core.

Table 18. Average Power Consumption of the NV08C-CSM in Time-to-Time-Fix Mode

Mode	Power supply options
Tracking & navigation, GPS only	< 120 mW
Tracking & navigation, GNSS	< 180 mW

2.4.2. Reset

NV08C-CSM's Input signal #RES (RESET, pin # 25) can be driven by the User's system to force the reset of the digital portion of the device. To reset the device the User's system should provide a pulse to the #Res input pad as specified below:

- Voltage level – less than 0.3xVCCIO
- The pulse length – no less than 1 ms

After the signal is applied (#RES signal level goes from low to high) the integrated power supervisor holds the device in reset mode for at least 140 ms. Please refer **Table 9** for Reset signal level requirements.

2.4.3. 1PPS Output

1PPS output is present at the GPIO1 pin. By default 1PPS signal is generated permanently and independently of a valid position fix whether available or not. If a valid position fix is not available, the 1PPS signal will be generated each second as per the internal hardware's defined time scale. If a valid position fix is available, the 1PPS signal refers to a user defined time standard (UTC by default). If required the 1PPS output can be set to operate only when a valid position fix is available.

1PPS signal parameters:

- Voltage level 1.8...3.3V (depends of VCCIO; CMOS)
- Output frequency 1 Hz
- True time Refer to the pulse rising (default) or the falling edge
- Pulse duration 38.5 ns to 2.5 ms (1 ms by default)
- Refers to UTC (default), GPS, GLONASS or UTC SU time standard
- 1PPS accuracy ± 15 ns (antenna cable delay to be compensated)
- 1PPS granularity 38.5 ns (26 MHz TCXO referenced)

The rising (or falling) edge shift is relative to the defined time-standard, and is available in the NMEA \$POUTC and BINR 72h message (generated within 20 ms after the 1PPS pulse).

2.4.4. Active Antenna connection

The NV08C-CSM requires an external active antenna. A 2.65V voltage supply is provided at the RF input to power the active antenna. If the antenna current draw exceeds 57 mA, the RF input supply voltage is automatically blocked by short-circuit protection.

It is very important to choose a proper antenna. An active antenna with too much LNA gain and wide passband may reduce the quality of signal reception due to possible in-band and out-of-band interference. As well an active antenna with too little gain or with high cable attenuation may decrease the receiver's sensitivity.

Recommended active antenna parameters are as follows:

- GPS/GLONASS L1, bandwidth 35 MHz @ $f_c = 1590$ MHz
- Gain including cable attenuation 20-30 dB
- Antenna noise figure <2 dB
- Out-of-band signal attenuation: at least 35dB @ $f_c \pm 70$ MHz.

If the active antenna requires a supply voltage other than 2.65 V, an external antenna power supply can be applied as shown in **Fig. 7**.

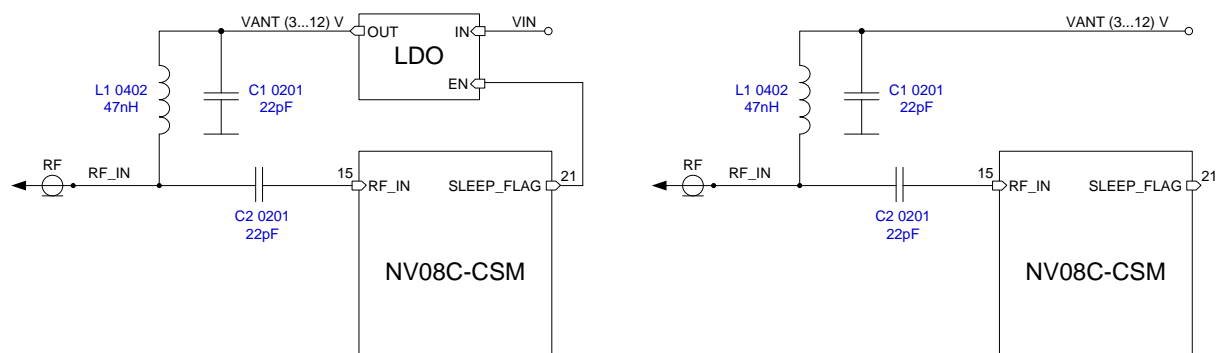

Fig. 7. Connection Options for an external active antenna with an external power source

Note – If an external power source is used, the built-in current detector and short circuit protection will not operate.

2.4.5. Digital IO Interfaces

The NV08C-CSM provides two UART interfaces, one SPI interface* (for FLASH/EEPROM connection), one two-wire interface (I²C compatible)* and GPIO interfaces.

* - these options are not available by default and are available only with a specific FW Patch (see chapter 3.5. FW update).

IO interfaces in NV08C-CSM are connected to external devices via 8 pins (GPIO7 – GPIO0).

Table 19. Default Configuration of pins P7 – P0

Pin	Status after RESET	Description
GPIO7	GPIO7	Configuration pads (See Table 20)
GPIO6	GPIO6	
GPIO5	GPIO5	
GPIO4	GPIO4	
GPIO3	GPIO3	
GPIO2	TimeMark	Currently reserved. The PIO can be re-allocated as External time synchronization input by FW Patch.
GPIO1	PPS	1 PPS output
GPIO0	ANTFLAG	Active antenna current trigger: "1" - Active antenna connected (current > 1.1mA) "0" - no load.

Note: The pads that are not used by the User's system as UART, 1PPS or TimeMark can be programmed as GPIO.

Table 20. Configuration Settings

GPIO (I/O number)	Function	PIO value	Description
GPIO7 (5)	Settings saving in BRAM	GPIO7 = 1 (default)	Save all settings
		GPIO7 = 0	Do not save settings
GPIO6 (35)	Allows FW Patch download via SPI A	GPIO6 = 1 (default)	GPIO7, GPIO5, GPIO4, GPIO3 used only for configuration purpose
		GPIO6 = 0	GPIO7, GPIO5, GPIO4, GPIO3 are configured as SPI and will be used for FW Patch download from external SPI-FLASH
GPIO5 (4) GPIO4 (7) GPIO3 (6)	UART port configuration	GPIO5 = 0 (default) GPIO4 = 0 (default) GPIO3 = 0 (default)	UART A – 115200 NMEA (GGA/1, RMC/1, GSV/1, GSA/1, RZD/1, GBS/10*) UART B – 115200 BINR
		GPIO5 = 0 GPIO4 = 0 GPIO3 = 1	UART A – 4800 NMEA (GGA/1, RMC/1, GSV/1, GSA/1, RZD/1, GBS/10*) UART B – 19200 BINR
		GPIO5 = 0 GPIO4 = 1 GPIO3 = 0	UART A – 9600 NMEA (GGA/1, RMC/1, GSV/1, GSA/1, RZD/1, GBS/10*) UART B – 19200 BINR

GPIO (I/O number)	Function	PIO value	Description
		GPIO5 = 0 GPIO4 = 1 GPIO3 = 1	UART A – 19200 NMEA (GGA/1, RMC/1, GSV/1, GSA/1, RZD/1, GBS/10*) UART B – 57600 BINR
		GPIO5 = 1 GPIO4 = 0 GPIO3 = 0	UART A – 38400 NMEA (GGA/1, RMC/1, GSV/1, GSA/1, RZD/1, GBS/10*) UART B – 38400 BINR
		GPIO5 = 1 GPIO4 = 0 GPIO3 = 1	UART A – 38400 NMEA (GNS/1, RMC/1, GSA/1, GBS/10, GSV/10, DTM/30*) UART B – 4800 RTCM
		GPIO5 = 1 GPIO4 = 1 GPIO3 = 0	UART A – 4800 NMEA (GNS/1, RMC/1, GSA/1, GBS/10, GSV/10, DTM/30*) UART B – 4800 RTCM
		GPIO5 = 1 GPIO4 = 1 GPIO3 = 1	UART A – 57600 NMEA (GGA/1, RMC/1, GSV/1, GSA/1, RZD/1, GBS/10*) UART B – 57600 BINR

* - default NMEA messages and time interval

Note – By default the NMEA output is enabled (GNS/1s, RMC/1s, GSA/1s, GBS/10s, GSV/10s, DTM/30s messages) and the BINR output is disabled. To enable the BINR output a query message must be sent (see Protocol Specification).

2.4.6. Backup Power Supply VBAT

If an independent VBAT voltage is applied, the NV08C-CSM module can store (in its BRAM) navigation parameters (almanac, ephemeris, last calculated coordinates etc.), as well as user defined settings (ports and receiver configuration settings).

When navigation parameters are stored, the module is able to provide warm or hot starts (depending on its switch-off time and available navigation data).

The user defined settings mode is defined by the GPIO7's signal level ("1" – saved, "0" – not saved). By default the GPIO7 is pulled-up ("1").

If no VBAT voltage is applied to the module, all data saved in the BRAM will be erased when the module is powered off.

3. Software and Protocols Reference

3.1. Data Protocol and Configuration

The NV08C-CSM can interface to an external host-processor using the following protocols:

- BINR (proprietary binary protocol)
- NMEA 0183
- RTCM v2.x (messages #1, #31)

Note – See description of communication messages in the Protocol Specification document.

By default, the module's interfaces are configured as follows:

- UART A: Protocol NMEA, 115,200 bps
- UART B: Protocol BINR, 115,200 bps

Note – Both ports can be configured to receive differential correctional data in RTCM format. Even in this configuration, it is still possible to control the module by adding NMEA-commands to the RTCM stream, since the NV08C-CSM's SW is able to sort out data types. In order to use this option the port must first be activated by a \$PORZA message to accept the RTCM data, then the NMEA message output stream can be defined by a \$PORZB message. (Refer to the Protocol Specification document for \$PORZA and \$PORZB messages description.)

Other NV08C-CSM default settings:

- navigation mode: GPS and GLONASS
- SBAS data: accounted automatically
- RAIM: automatic
- Assisted data: accounted automatically
- navigation data update rate: 1 Hz
- NMEA messages: GSA, RMC, GGA, GSV, GBS

Standard settings can be changed by using the following means:

- pre-set configuration codes to assign certain specific GPIO inputs (refer to Table 20 GPIO7 – GPIO3 settings)
- NMEA/BINR protocol commands via UART A/B ports

3.2. Low Power Battery Mode

The NV08C-CSM has a sophisticated system to reduce its power consumption. The supported power conservation methods are as follows:

- automatic clock gating of unused subsystems (such as the fast search function, unused correlation channels, and interface blocks)
- option to completely turn-off the power to one of the two analogue channels

3.3. Sleep Mode

If navigation function is not required power consumption can be minimized by switching the NV08C-CSM device to Sleep mode. A Host system can activate the Sleep mode by sending the

\$POPW,1111*66<CR><LF> NMEA command. When NV08C-CSM enters the Sleep Mode SLEEP_FLAG pin goes to LOW state, Both RF-chains and TCXO are turned off and BB ASIC consumes minimal power.

Note: The time interval required for NV08C-CSM device to enter Sleep mode depends on the communication baud rate since NMEA commands should be received and decoded. After commands decoding a minimum of 10 ms is required for the device to safely enter Sleep mode.

The NV08C-CSM device wakes up when the Host System sends any command via UART port.

Note: The NV08C-CSM device is sensitive to the falling edge of UART RX signals. A minimum of 10 ms after detecting a falling edge is required to switch the device from IDLE to normal operation mode, otherwise the first sent command cannot be properly decoded. Therefore a timeout is required prior to sending of the next control command by the Host System.

3.4. Assisted GNSS

The NV08C-CSM supports the use of external assisted data functions for applications that require quick-navigation on power-up. Assisted data is provided by the User's system via wireless means such as GSM or CDMA, or by the Internet, and loaded onto the module via the BINR protocol. Assisted data comes in a compact format (binary data file) and is ready for download on supported sites.

3.5. FW update

To download Patch Code (FW) via a UART interface (**Fig. 8**) the following command must be sent to the NV08C-CSM:

- for NMEA protocol: \$POPRL,R*2F\r\n
- for BINR protocol: 0x10 0x01 0x52 0x45 0x4C 0x4F 0x41 0x44 0x5F 0x52 0x10 0x03

By receiving the command the NV08C-CSM shifts into programming mode and starts the output of character 0x43 (in ASCII – character "C") to UART TX. In response the User's system must download Patch Code in the form of sequence of bytes (provided as a binary file) by means of X-modem-CRC protocol. As soon as the binary file is completely downloaded the module stores the Patch Code in its non-volatile memory and restarts.

NVS Technologies can support application specific requirements. Contact NVS' Technical Support for customisation of standard functionalities.

The PatchWriter (Firmware downloading tool) and the latest revision of the Firmware Patch (FW) are available at www.nvs-gnss.com.

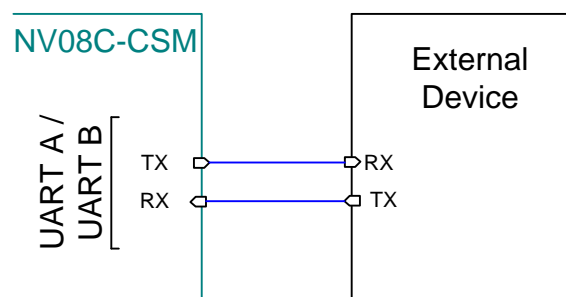

Fig. 8. Connecting the NV08C-CSM to an external device to download Patch Code (FW)

FW updating via Patch downloads can be performed for an unlimited number of times (within the FLASH memory specification – typically up to 100K writing cycles). First the old FW Patch is erased from memory then the new FW Patch is stored to memory. Any FW Patch version corresponding to the MaskROM version can be downloaded to the NV08C-CSM. (For example - the newer version of the Patch can be downgraded by downloading an older version.) However if a Patch version being downloaded doesn't correspond to the module MaskROM version, the Patch will not be stored in the FLASH memory.

FW versions **02.xx** and **01.xx** are only compatible with NV08C-CSM v.3.x Hardware. FW 02.xx is used for official FW releases (recommended for all users). FW 01.xx supposes a customization of official FW version for specific user demands.

IMPORTANT NOTE: *Don't load FW 04.xx or 03.xx into NV08C-CSM v.3.x. Not following this prescription might lead to unrecoverable device malfunction.*

FW version 04.xx and 03.xx are only compatible with NV08C-CSM v.4.x Hardware. FW 04.xx is used for official FW releases (recommended for all users). FW 03.xx supposes a customization of official FW version for specific user demands.

IMPORTANT NOTE: *don't load FW 02.xx or 01.xx into NV08C-CSM v.4.x. Not following this prescription might lead to unrecoverable device malfunction.*

Caution – Storing of the Patch to the FLASH memory will only begin when transmission of the Patch to the module is fully completed (this will require a few seconds). During this process the NV08C-CSM must not be powered-off and RESET must not be applied. Turning off or resetting while doing a Patch download might lead to a malfunction of the NV08C-CSM and recovery can only be done by the factory.

3.6. Dead Reckoning Option

The NV08C-CSM features a Dead Reckoning function which provides seamless navigation even when satellite signals are partially blocked or completely unavailable (example: tree canopy, urban canyons, covered parking, tunnels, mountains etc.). The NV08C-CSM's Dead Reckoning algorithm is intended for automotive applications that provide two wheel-pulse signals from a single-axle.

Note – *the User's system must match the signal levels to the NV08C-CSM's GPIO inputs.*

Please contact NVS' Technical Support to obtain Dead Reckoning FW option support.

Recommended Land Pattern

(5:1)

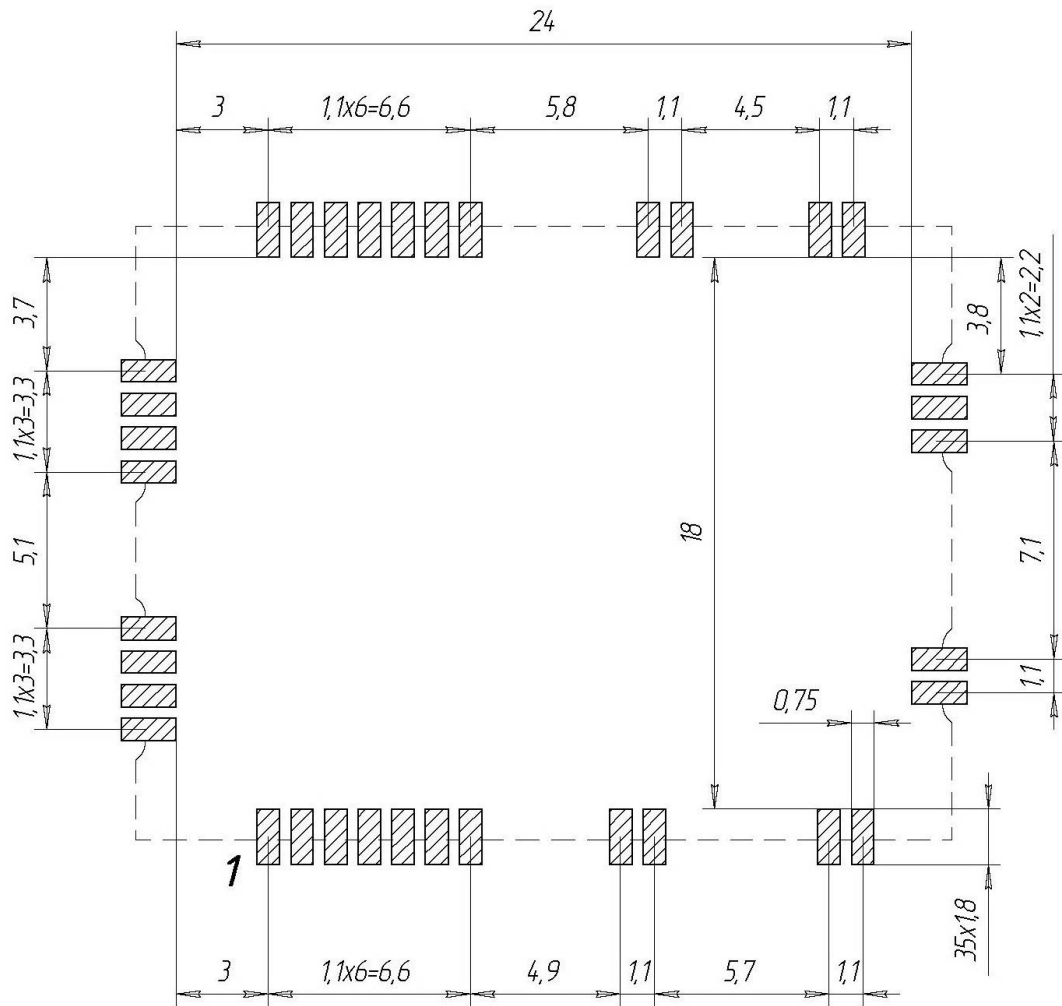

Appendix 2. NV08C-CSM Recommended Solder Reflow Profile

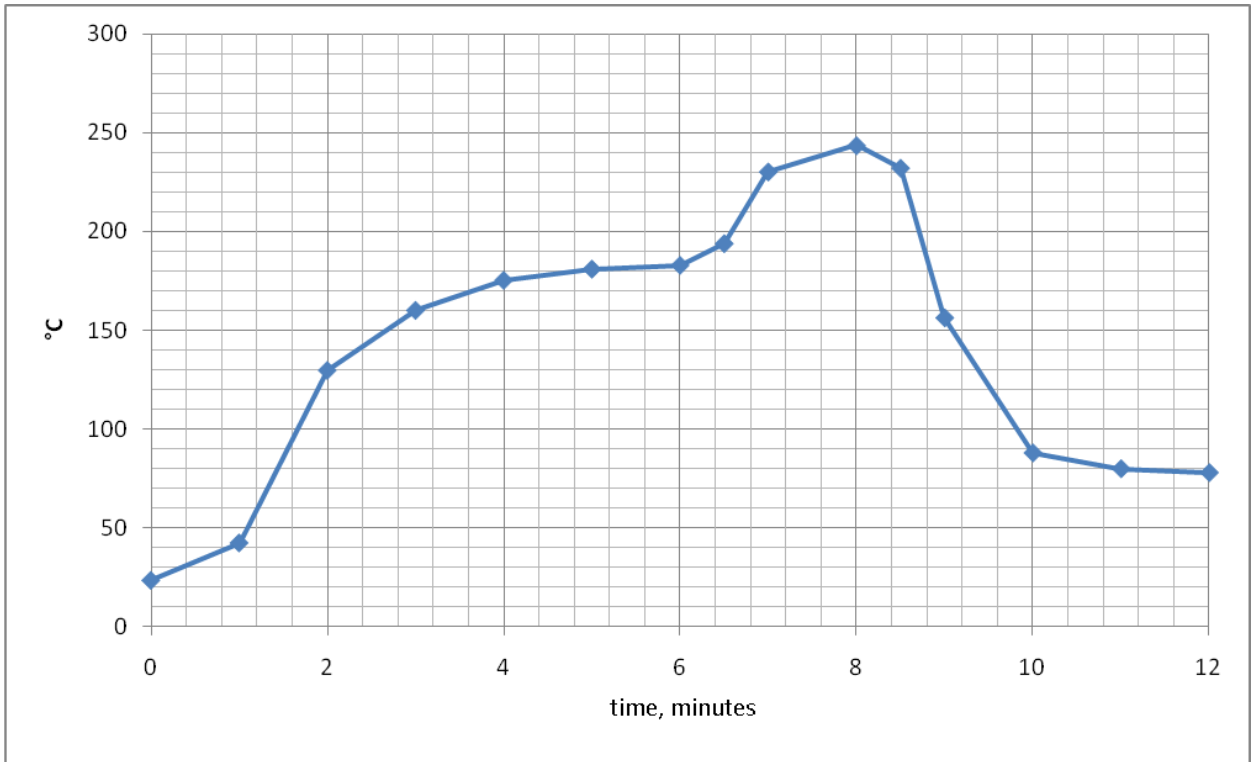

Appendix 3. Packaging Information

Device quantity is 50 pieces per JEDEC tray (10 JEDEC trays maximum per box).

Top view of the tray is shown in the picture below.

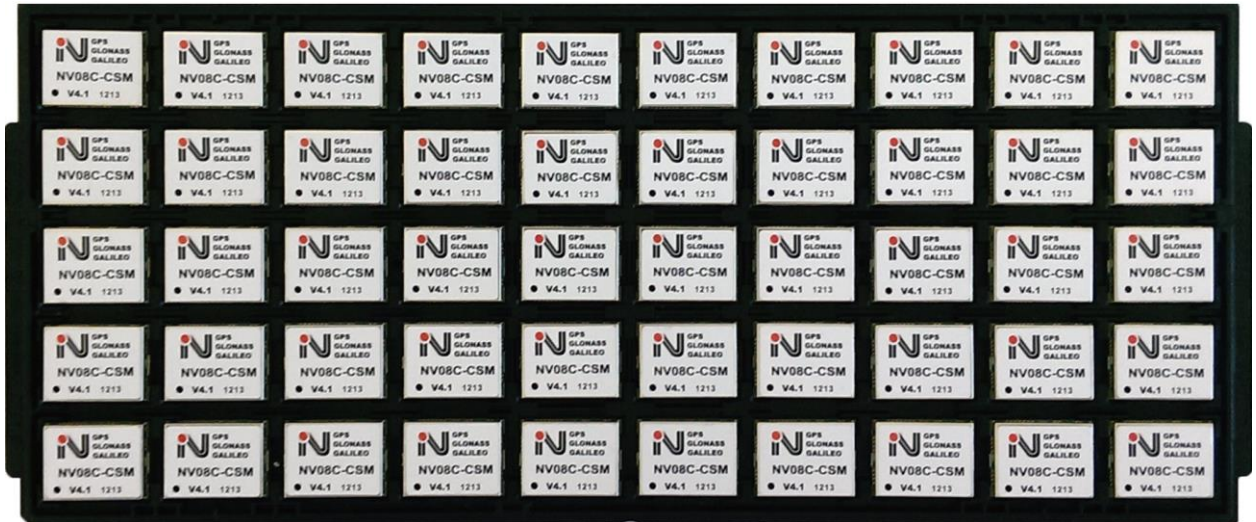

X-ON Electronics

Largest Supplier of Electrical and Electronic Components

Click to view similar products for [nvs technologies](#) manufacturer:

Other Similar products are found below :

[NV08C-CSM](#)