

DATA SHEET

74ALVT16543

**2.5 V/3.3 V ALVT 16-bit registered
transceiver (3-State)**

Product data sheet
Supersedes data of 1998 Feb 13

2004 Sep 14

2.5 V/3.3 V 16-bit registered transceiver (3-State)

74ALVT16543

FEATURES

- 16-bit universal bus interface
- 5 V I/O Compatible
- 3-State buffers
- Output capability: +64 mA/-32 mA
- TTL input and output switching levels
- Input and output interface capability to systems at 5 V supply
- Bus-hold data inputs eliminate the need for external pull-up resistors to hold unused inputs
- Live insertion/extraction permitted
- Power-up 3-State
- Power-up reset
- No bus current loading when output is tied to 5 V bus
- Latch-up protection exceeds 500mA per JEDEC Std 17
- ESD protection exceeds 2000 V per MIL STD 883 Method 3015 and 200 V per Machine Model

DESCRIPTION

The 74ALVT16543 is a high-performance BiCMOS product designed for V_{CC} operation at 2.5 V or 3.3 V with I/O compatibility up to 5 V. The device can be used as two 8-bit transceivers or one 16-bit transceiver.

The 74ALVT16543 contains two sets of eight D-type latches, with separate control pins for each set. Using data flow from A to B as an example, when the A-to-B Enable ($n\overline{EAB}$) input and the A-to-B Latch Enable ($n\overline{LEAB}$) input are LOW, the A-to-B path is transparent.

A subsequent LOW-to-HIGH transition of the $n\overline{LEAB}$ signal puts the A data into the latches where it is stored and the B outputs no longer change with the A inputs. With $n\overline{EAB}$ and $n\overline{OEAB}$ both LOW, the 3-State B output buffers are active and display the data present at the outputs of the A latches.

Control of data flow from B to A is similar, but using the $n\overline{EBA}$, $n\overline{LEBA}$, and $n\overline{OEBA}$ inputs.

Active bus-hold circuitry is provided to hold unused or floating data inputs at a valid logic level.

QUICK REFERENCE DATA

SYMBOL	PARAMETER	CONDITIONS $T_{amb} = 25\text{ }^\circ\text{C}; \text{GND} = 0\text{ V}$	TYPICAL		UNIT
			2.5 V	3.3 V	
t_{PLH} t_{PHL}	Propagation delay nAx to nBx or nBx to nAx	$C_L = 50\text{ pF}$	1.8 2.7	1.6 1.8	ns
C_{IN}	Input capacitance DIR, \overline{OE}	$V_I = 0\text{ V or }V_{CC}$	3	3	pF
$C_{I/O}$	I/O pin capacitance	Outputs disabled; $V_{I/O} = 0\text{ V or }V_{CC}$	9	9	pF
I_{CCZ}	Total supply current	Outputs disabled	40	70	μA

ORDERING INFORMATION

PACKAGES	TEMPERATURE RANGE	TYPE NUMBER	DWG NUMBER
56-Pin Plastic SSOP Type III	-40 °C to +85 °C	74ALVT16543DL	SOT371-1
56-Pin Plastic TSSOP Type II	-40 °C to +85 °C	74ALVT16543DGG	SOT364-1

LOGIC SYMBOL (IEEE/IEC)

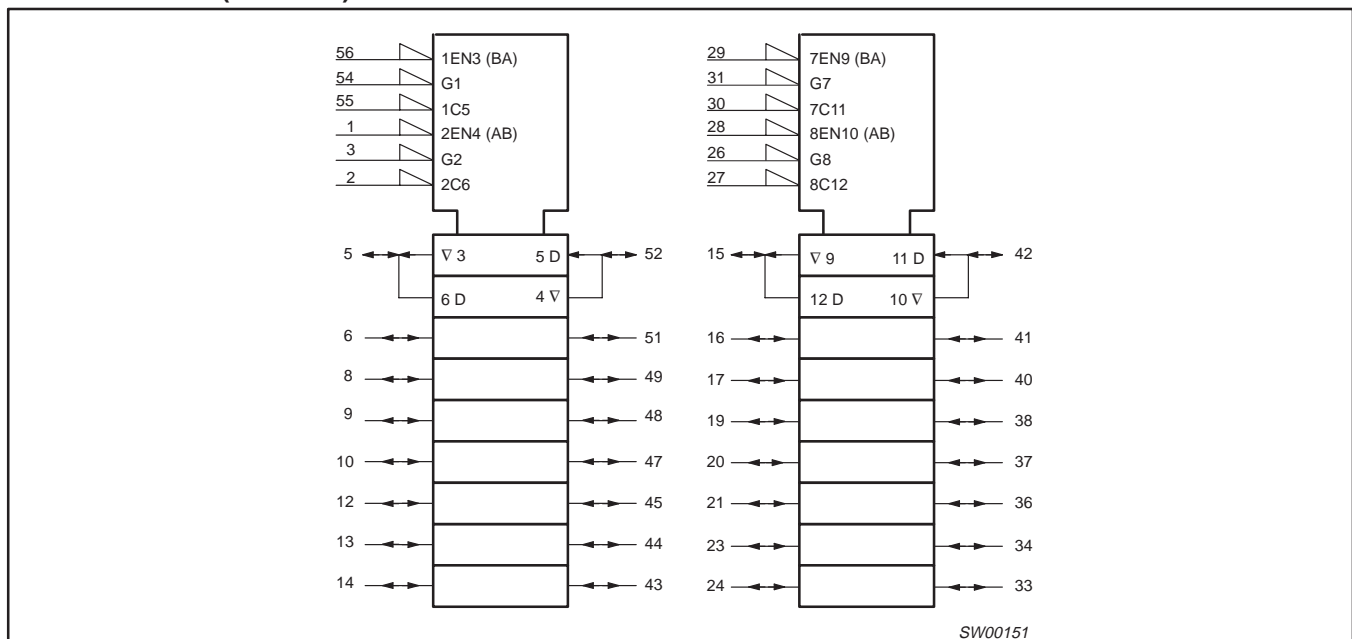

2.5 V/3.3 V 16-bit registered transceiver (3-State)

74ALVT16543

PIN CONFIGURATION

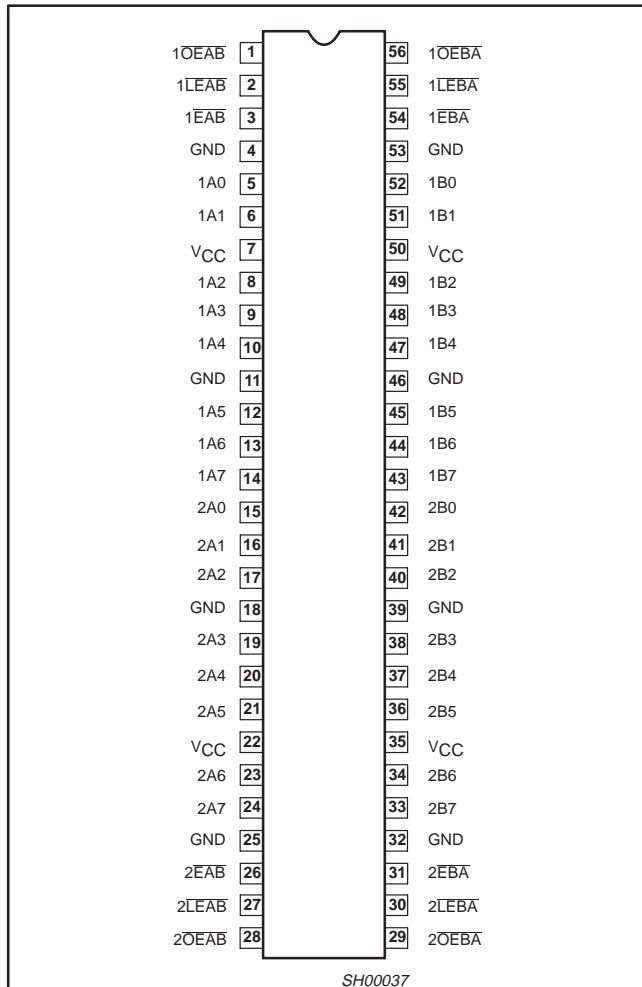

LOGIC SYMBOL

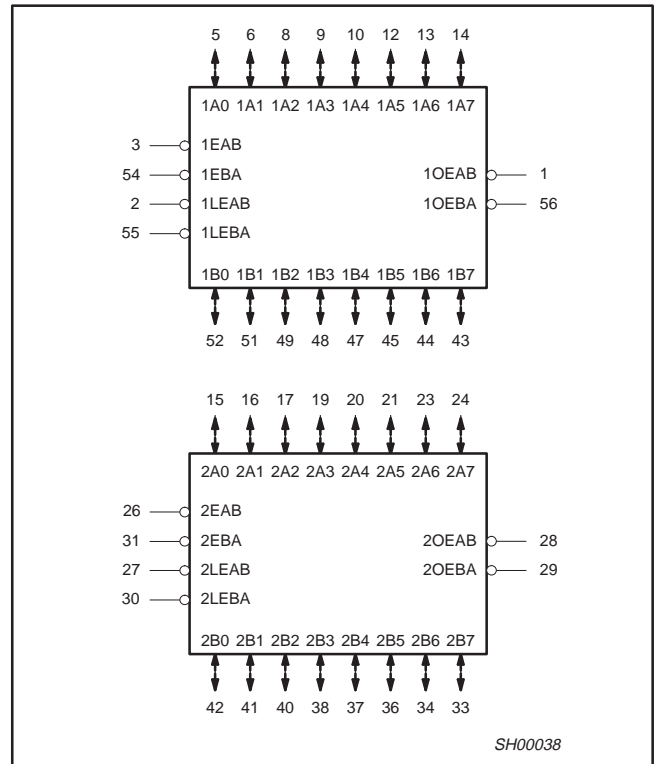

PIN DESCRIPTION

PIN NUMBER	SYMBOL	NAME AND FUNCTION
5, 6, 8, 9, 10, 12, 13, 14 15, 16, 17, 19, 20, 21, 23, 24	1A0 – 1A7, 2A0 – 2A7	A Data inputs/outputs
52, 51, 49, 48, 47, 45, 44, 43 42, 41, 40, 38, 37, 36, 34, 33	1B0 – 1B7, 2B0 – 2B7	B Data inputs/outputs
1, 56 28, 29	1OEAB, 1OEBA, 2OEAB, 2OEBA	A to B / B to A Output Enable inputs (active-LOW)
3, 54 26, 31	1EAB, 1EBA, 2EAB, 2EBA	A to B / B to A Enable inputs (active-LOW)
2, 55 27, 30	1LEAB, 1LEBA, 2LEAB, 2LEBA	A to B / B to A Latch Enable inputs (active-LOW)
4, 11, 18, 25, 32, 39, 46, 53	GND	Ground (0 V)
7, 22, 35, 50	V _{CC}	Positive supply voltage

2.5 V/3.3 V 16-bit registered transceiver (3-State)

74ALVT16543

LOGIC DIAGRAM

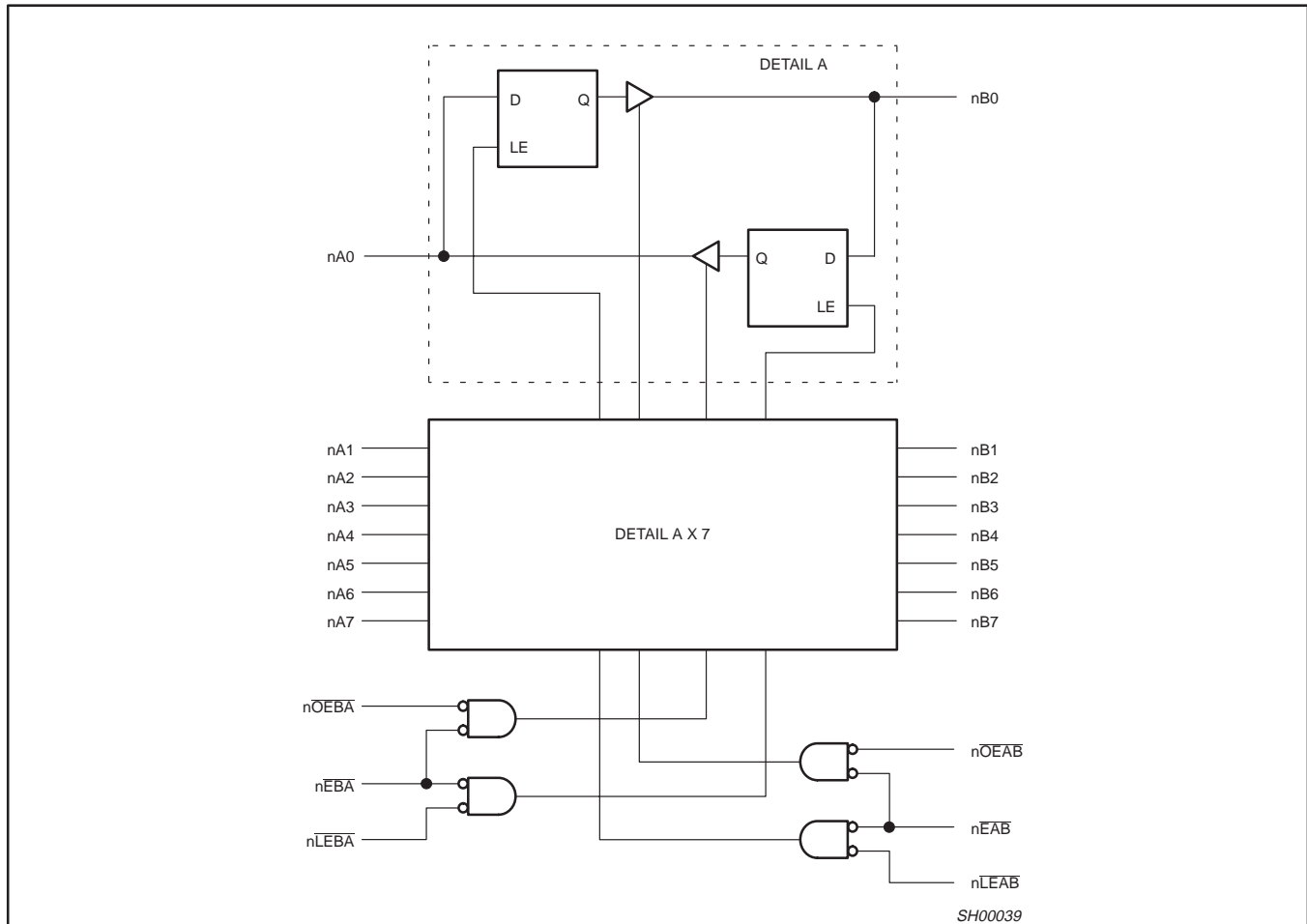

FUNCTION TABLE

INPUTS				OUTPUTS	STATUS
nOE _{XX}	nEX _{XX}	nLE _{XX}	nA _x or nB _x	nB _x or nA _x	
H	X	X	X	Z	Disabled
X	H	X	X	Z	Disabled
L	↑	L	h	Z	Disabled + Latch
L	↑	L	l	Z	
L	L	↑	h	H	Latch + Display
L	L	↑	l	L	
L	L	L	H	H	Transparent
L	L	L	L	L	
L	L	H	X	NC	Hold

H = HIGH voltage level
 h = HIGH voltage level one setup time prior to the LOW-to-HIGH transition of nLE_{XX} or nEX_{XX} (XX = AB or BA)
 L = LOW voltage level
 l = LOW voltage level one setup time prior to the LOW-to-HIGH transition of nLE_{XX} or nEX_{XX} (XX = AB or BA)
 X = Don't care
 ↑ = LOW-to-HIGH transition of nLE_{XX} or nEX_{XX} (XX = AB or BA)
 NC = No change
 Z = High-impedance or "off" state

2.5 V/3.3 V 16-bit registered transceiver (3-State)

74ALVT16543

ABSOLUTE MAXIMUM RATINGS^{1, 2}

SYMBOL	PARAMETER	CONDITIONS	RATING	UNIT
V _{CC}	DC supply voltage		-0.5 to +4.6	V
I _{IK}	DC input diode current	V _I < 0 V	-50	mA
V _I	DC input voltage ³		-0.5 to +7.0	V
I _{OK}	DC output diode current	V _O < 0 V	-50	mA
V _{OUT}	DC output voltage ³	Output in Off or HIGH state	-0.5 to +7.0	V
I _{OUT}	DC output current	Output in LOW state	128	mA
		Output in HIGH state	-64	
T _{stg}	Storage temperature range		-65 to +150	°C

NOTES:

- Stresses beyond those listed may cause permanent damage to the device. These are stress ratings only and functional operation of the device at these or any other conditions beyond those indicated under "recommended operating conditions" is not implied. Exposure to absolute-maximum-rated conditions for extended periods may affect device reliability.
- The performance capability of a high-performance integrated circuit in conjunction with its thermal environment can create junction temperatures which are detrimental to reliability. The maximum junction temperature of this integrated circuit should not exceed 150 °C.
- The input and output negative voltage ratings may be exceeded if the input and output clamp current ratings are observed.

RECOMMENDED OPERATING CONDITIONS

SYMBOL	PARAMETER	2.5 V RANGE LIMITS		3.3 V RANGE LIMITS		UNIT
		MIN	MAX	MIN	MAX	
V _{CC}	DC supply voltage	2.3	2.7	3.0	3.6	V
V _I	Input voltage	0	5.5	0	5.5	V
V _{IH}	HIGH-level input voltage	1.7		2.0		V
V _{IL}	Input voltage		0.7		0.8	V
I _{OH}	HIGH-level output current		-8		-32	mA
I _{OL}	LOW-level output current		8		32	mA
	LOW-level output current; current duty cycle ≤ 50 %; f ≥ 1 kHz		24		64	
Δt/Δv	Input transition rise or fall rate; Outputs enabled		10		10	ns/V
T _{amb}	Operating free-air temperature range	-40	+85	-40	+85	°C

2.5 V/3.3 V 16-bit registered transceiver (3-State)

74ALVT16543

DC ELECTRICAL CHARACTERISTICS (3.3 V \pm 0.3 V RANGE)

SYMBOL	PARAMETER	TEST CONDITIONS	LIMITS			UNIT	
			Temp = -40 °C to +85 °C				
			MIN	TYP ¹	MAX		
V _{IK}	Input clamp voltage	V _{CC} = 3.0 V; I _{IK} = -18 mA	-	-0.85	-1.2	V	
V _{OH}	HIGH-level output voltage	V _{CC} = 3.0 V to 3.6 V; I _{OH} = -100 μ A	V _{CC} - 0.2	V _{CC}	-	V	
		V _{CC} = 3.0 V; I _{OH} = -32 mA	2.0	2.3	-		
V _{OL}	LOW-level output voltage	V _{CC} = 3.0 V; I _{OL} = 100 μ A	-	0.07	0.2	V	
		V _{CC} = 3.0 V; I _{OL} = 16 mA	-	0.25	0.4		
		V _{CC} = 3.0 V; I _{OL} = 32 mA	-	0.3	0.5		
		V _{CC} = 3.0 V; I _{OL} = 64 mA	-	0.4	0.55		
V _{RST}	Power-up output low voltage ⁶	V _{CC} = 3.6 V; I _O = 1 mA; V _I = V _{CC} or GND	-	-	0.55	V	
I _I	Input leakage current	V _{CC} = 3.6 V; V _I = V _{CC} or GND	Control pins	-	0.1	\pm 1	μ A
		V _{CC} = 0 V or 3.6 V; V _I = 5.5 V		-	0.1	10	
		V _{CC} = 3.6 V; V _I = V _{CC}	Data pins ⁴	-	0.5	1	
		V _{CC} = 3.6 V; V _I = 0 V		-	0.1	-5	
		V _{CC} = 3.6 V; V _I = 5.5 V		-	0.1	20	
I _{OFF}	Off current	V _{CC} = 0 V; V _I or V _O = 0 V to 4.5 V	-	0.1	\pm 100	μ A	
I _{HOLD}	Bus Hold current Data inputs ⁷	V _{CC} = 3 V; V _I = 0.8 V	75	130	-	μ A	
		V _{CC} = 3 V; V _I = 2.0 V	-75	-140	-		
		V _{CC} = 0 V to 3.6 V; V _{CC} = 3.6 V	\pm 500	-	-		
I _{EX}	Current into an output in the High state when V _O > V _{CC}	V _O = 5.5 V; V _{CC} = 3.0 V	-	50	125	μ A	
I _{PU/PD}	Power-up/down 3-State output current ³	V _{CC} \leq 1.2 V; V _O = 0.5 V to V _{CC} ; V _I = GND or V _{CC} ; OE/OE = Don't care	-	40	\pm 100	μ A	
I _{CCH}	Quiescent supply current	V _{CC} = 3.6 V; Outputs HIGH; V _I = GND or V _{CC} ; I _O = 0 mA	-	0.07	0.1	mA	
I _{CCL}		V _{CC} = 3.6 V; Outputs LOW; V _I = GND or V _{CC} ; I _O = 0 mA	-	3.6	5		
I _{CCZ}		V _{CC} = 3.6 V; Outputs disabled; V _I = GND or V _{CC} ; I _O = 0 mA ⁵	-	0.07	0.1		
Δ I _{CC}	Additional supply current per input pin ²	V _{CC} = 3 V to 3.6 V; One input at V _{CC} - 0.6 V; Other inputs at V _{CC} or GND	-	0.04	0.4	mA	

NOTES:

- All typical values are at V_{CC} = 3.3 V and T_{amb} = 25 °C.
- This is the increase in supply current for each input at the specified voltage level other than V_{CC} or GND.
- This parameter is valid for any V_{CC} between 0 V and 1.2 V with a transition time of up to 10 msec. From V_{CC} = 1.2 V to V_{CC} = 3.3 V \pm 0.3 V a transition time of 100 μ sec is permitted. This parameter is valid for T_{amb} = 25 °C only.
- Unused pins at V_{CC} or GND.
- I_{CCZ} is measured with outputs pulled up to V_{CC} or pulled down to ground.
- For valid test results, data must not be loaded into the flip-flops (or latches) after applying power.
- This is the bus hold overdrive current required to force the input to the opposite logic state.

2.5 V/3.3 V 16-bit registered transceiver (3-State)

74ALVT16543

DC ELECTRICAL CHARACTERISTICS (2.5 V \pm 0.2 V RANGE)

SYMBOL	PARAMETER	TEST CONDITIONS	LIMITS			UNIT	
			Temp = -40 °C to +85 °C				
			MIN	TYP ¹	MAX		
V _{IK}	Input clamp voltage	V _{CC} = 2.3 V; I _{IK} = -18 mA	-	-0.85	-1.2	V	
V _{OH}	HIGH-level output voltage	V _{CC} = 2.3 V to 3.6 V; I _{OH} = -100 μ A	V _{CC} - 0.2	V _{CC}	-	V	
		V _{CC} = 2.3 V; I _{OH} = -8 mA	1.8	2.1	-		
V _{OL}	LOW-level output voltage	V _{CC} = 2.3 V; I _{OL} = 100 μ A	-	0.07	0.2	V	
		V _{CC} = 2.3 V; I _{OL} = 24 mA	-	0.3	0.5		
		V _{CC} = 2.3 V; I _{OL} = 8 mA	-	-	0.4		
V _{RST}	Power-up output low voltage ⁷	V _{CC} = 2.7 V; I _O = 1 mA; V _I = V _{CC} or GND	-	-	0.55	V	
I _I	Input leakage current	V _{CC} = 2.7 V; V _I = V _{CC} or GND	Control pins	-	0.1	\pm 1	μ A
		V _{CC} = 0 V or 2.7 V; V _I = 5.5 V		-	0.1	10	
		V _{CC} = 2.7 V; V _I = 5.5 V	Data pins ⁴	-	0.1	20	
		V _{CC} = 2.7 V; V _I = V _{CC}		-	0.1	10	
		V _{CC} = 2.7 V; V _I = 0 V		-	0.1	-5	
I _{OFF}	Off current	V _{CC} = 0 V; V _I or V _O = 0 V to 4.5 V	-	0.1	\pm 100	μ A	
I _{HOLD}	Bus Hold current	V _{CC} = 2.3 V; V _I = 0.7 V	-	120	-	μ A	
	Data inputs ⁶	V _{CC} = 2.3 V; V _I = 1.7 V	-	-6	-		
I _{EX}	Current into an output in the HIGH state when V _O > V _{CC}	V _O = 5.5 V; V _{CC} = 2.3 V	-	50	125	μ A	
I _{PU/PD}	Power-up/down 3-State output current ³	V _{CC} \leq 1.2 V; V _O = 0.5 V to V _{CC} ; V _I = GND or V _{CC} ; OE/OE = Don't care	-	40	100	μ A	
I _{CCH}	Quiescent supply current	V _{CC} = 2.7 V; Outputs HIGH, V _I = GND or V _{CC} ; I _O = 0 mA	-	0.04	0.1	mA	
I _{CCL}		V _{CC} = 2.7 V; Outputs LOW, V _I = GND or V _{CC} ; I _O = 0 mA	-	2.6	4.5		
I _{CCZ}		V _{CC} = 2.7 V; Outputs disabled; V _I = GND or V _{CC} ; I _O = 0 mA ⁵	-	0.04	0.1		
Δ I _{CC}	Additional supply current per input pin ²	V _{CC} = 2.3 V to 2.7 V; One input at V _{CC} - 0.6 V; Other inputs at V _{CC} or GND	-	0.01	0.4	mA	

NOTES:

- All typical values are at V_{CC} = 2.5 V and T_{amb} = 25 °C.
- This is the increase in supply current for each input at the specified voltage level other than V_{CC} or GND.
- This parameter is valid for any V_{CC} between 0 V and 1.2 V with a transition time of up to 10 msec. From V_{CC} = 1.2 V to V_{CC} = 2.5 V \pm 0.2 V a transition time of 100 μ sec is permitted. This parameter is valid for T_{amb} = 25 °C only.
- Unused pins at V_{CC} or GND.
- I_{CCZ} is measured with outputs pulled up to V_{CC} or pulled down to ground.
- Not guaranteed.
- For valid test results, data must not be loaded into the flip-flops (or latches) after applying power.

2.5 V/3.3 V 16-bit registered transceiver (3-State)

74ALVT16543

AC CHARACTERISTICS (3.3 V ± 0.3 V RANGE)GND = 0 V; $t_R = t_F = 2.5$ ns; $C_L = 50$ pF; $R_L = 500$ Ω ; $T_{amb} = -40$ °C to +85 °C.

SYMBOL	PARAMETER	WAVEFORM	LIMITS			UNIT
			$V_{CC} = 3.3$ V \pm 0.3 V			
			MIN	TYP ¹	MAX	
t_{PLH} t_{PHL}	Propagation delay nAx to nBx or nBx to nAx	2	0.5 0.5	1.6 1.8	2.6 3.0	ns
t_{PLH} t_{PHL}	Propagation delay nLEBA to nAx, nLEAB to nBx	1 2	1.0 1.0	2.4 2.4	4.0 4.0	ns
t_{PZH} t_{PZL}	Output enable time nOEBA to nAx, nOEAB to nBx	4 5	1.0 1.0	2.3 1.8	4.0 3.1	ns
t_{PHZ} t_{PLZ}	Output disable time nOEBA to nAx, nOEAB to nBx	4 5	1.0 1.0	3.1 2.7	4.8 4.2	ns
t_{PZH} t_{PZL}	Output enable time nEBA to nAx, nEAB to nBx	4 5	1.0 1.0	2.5 1.9	4.2 3.1	ns
t_{PHZ} t_{PLZ}	Output disable time nEBA to nAx, nEAB to nBx	4 5	1.0 1.0	2.9 2.4	4.9 4.2	ns

NOTE:1. All typical values are at $V_{CC} = 3.3$ V and $T_{amb} = 25$ °C.**AC SETUP REQUIREMENTS (3.3 V ± 0.3 V RANGE)**GND = 0 V; $t_R = t_F = 2.5$ ns; $C_L = 50$ pF; $R_L = 500$ Ω ; $T_{amb} = -40$ °C to +85 °C.

SYMBOL	PARAMETER	WAVEFORM	LIMITS		UNIT
			$V_{CC} = 3.3$ V \pm 0.3 V		
			MIN	TYP	
$t_s(H)$ $t_s(L)$	Setup time nAx to nLEAB, nBx to nLEBA	3	0.5 0.7	0 -0.4	ns
$t_h(H)$ $t_h(L)$	Hold time nAx to nLEAB, nBx to nLEBA	3	1.5 1.5	0.2 -0.3	ns
$t_s(H)$ $t_s(L)$	Setup time nAx to nEAB, nBx to nEBA	3	0.5 1.1	-0.3 -0.6	ns
$t_h(H)$ $t_h(L)$	Hold time nAx to nEAB, nBx to nEBA	3	1.2 2.0	0.6 0.1	ns
$t_W(L)$	Latch enable pulse width, LOW	3	1.5	-	ns

2.5 V/3.3 V 16-bit registered transceiver (3-State)

74ALVT16543

AC CHARACTERISTICS (2.5 V ± 0.2 V RANGE)GND = 0 V; $t_R = t_F = 2.5$ ns; $C_L = 50$ pF; $R_L = 500$ Ω ; $T_{amb} = -40$ °C to +85 °C.

SYMBOL	PARAMETER	WAVEFORM	LIMITS			UNIT
			$V_{CC} = 2.5 \text{ V} \pm 0.2 \text{ V}$			
			MIN	TYP ¹	MAX	
t_{PLH} t_{PHL}	Propagation delay nAx to nBx or nBx to nAx	2	1.0 1.0	1.8 2.7	5.1 4.5	ns
t_{PLH} t_{PHL}	Propagation delay nLEBA to nAx, nLEAB to nBx	1 2	1.5 1.5	3.9 3.6	6.4 5.9	ns
t_{PZH} t_{PZL}	Output enable time nOEBA to nAx, nOEAB to nBx	4 5	1.5 1.5	4.0 2.7	6.5 4.6	ns
t_{PHZ} t_{PLZ}	Output disable time nOEBA to nAx, nOEAB to nBx	4 5	1.5 1.5	3.7 2.6	5.6 4.0	ns
t_{PZH} t_{PZL}	Output enable time nEBA to nAx, nEAB to nBx	4 5	1.5 1.5	4.2 2.8	7.0 5.0	ns
t_{PHZ} t_{PLZ}	Output disable time nEBA to nAx, nEAB to nBx	4 5	1.5 1.5	3.6 2.4	5.6 3.9	ns

NOTE:1. All typical values are at $V_{CC} = 2.5$ V and $T_{amb} = 25$ °C.**AC SETUP REQUIREMENTS (2.5 V ± 0.2 V RANGE)**GND = 0 V; $t_R = t_F = 2.5$ ns; $C_L = 50$ pF; $R_L = 500$ Ω ; $T_{amb} = -40$ °C to +85 °C.

SYMBOL	PARAMETER	WAVEFORM	LIMITS		UNIT
			$V_{CC} = 2.5 \text{ V} \pm 0.2 \text{ V}$		
			MIN	TYP	
$t_s(H)$ $t_s(L)$	Setup time nAx to nLEAB, nBx to nLEBA	3	0.5 1.0	-0.2 -0.5	ns
$t_h(H)$ $t_h(L)$	Hold time nAx to nLEAB, nBx to nLEBA	3	1.0 1.0	0.2 -0.2	ns
$t_s(H)$ $t_s(L)$	Setup time nAx to nEAB, nBx to nEBA	3	0.5 1.5	-0.3 -0.6	ns
$t_h(H)$ $t_h(L)$	Hold time nAx to nEAB, nBx to nEBA	3	1.2 1.5	0 0.2	ns
$t_W(L)$	Latch enable pulse width, LOW	3	1.5	-	ns

2.5 V/3.3 V 16-bit registered transceiver (3-State)

74ALVT16543

AC WAVEFORMS

For all waveforms $V_M = 1.5\text{ V}$ or $V_{CC}/2$, whichever is less.

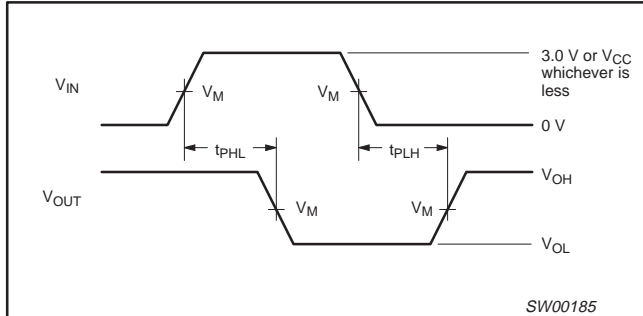

Waveform 1. Propagation Delay For Inverting Output

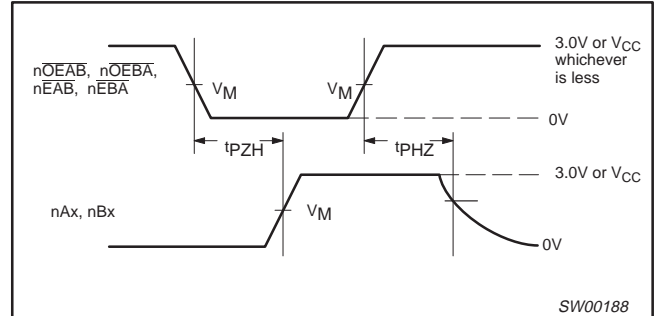

Waveform 4. 3-State Output Enable Time to High Level and Output Disable Time from High Level

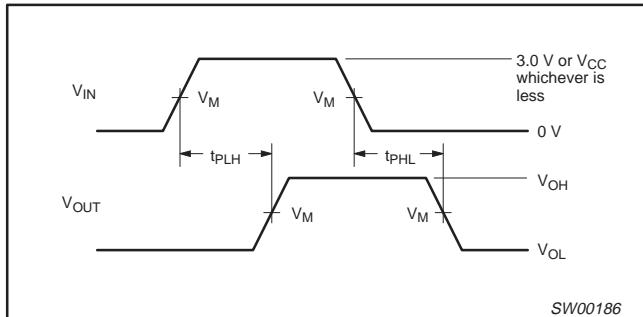

Waveform 2. Propagation Delay For Non-Inverting Output

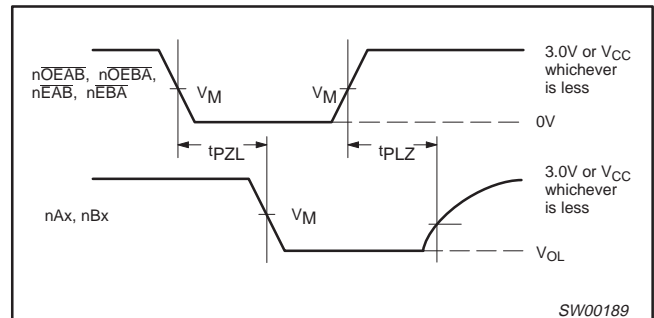

Waveform 5. 3-State Output Enable Time to Low Level and Output Disable Time from Low Level

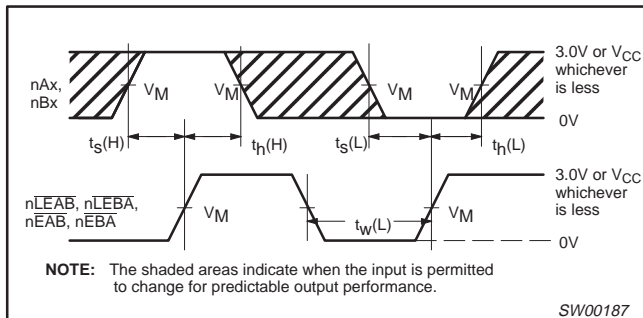

Waveform 3. Data Setup and Hold Times and Latch Enable Pulse Width

NOTE: The shaded areas indicate when the input is permitted to change for predictable output performance.

2.5 V/3.3 V 16-bit registered transceiver (3-State)

74ALVT16543

TEST CIRCUIT AND WAVEFORMS

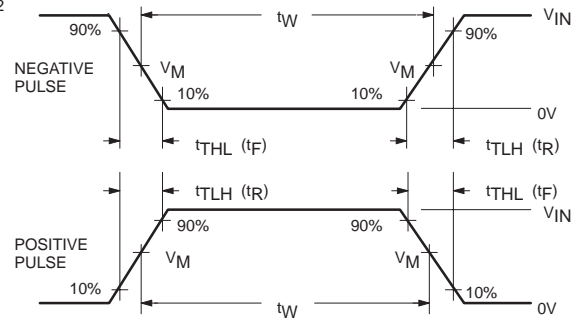
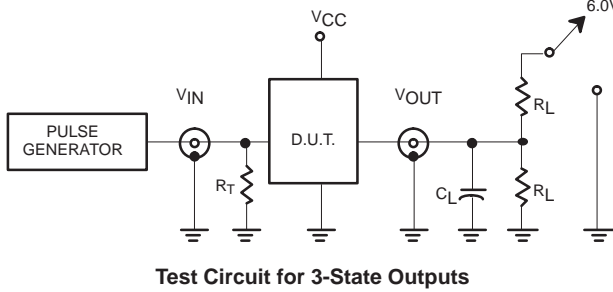

SWITCH POSITION

TEST	SWITCH
t_{PLZ}/t_{PZL}	6V or $V_{CC} \times 2$
t_{PLH}/t_{PHL}	Open
t_{PHZ}/t_{PZH}	GND

DEFINITIONS

- R_L = Load resistor; see AC CHARACTERISTICS for value.
- C_L = Load capacitance includes jig and probe capacitance: See AC CHARACTERISTICS for value.
- R_T = Termination resistance should be equal to Z_{OUT} of pulse generators.

FAMILY	INPUT PULSE REQUIREMENTS				
	Amplitude	Rep. Rate	t_W	t_R	t_F
74ALVT16	3.0V or V_{CC} whichever is less	$\leq 10\text{MHz}$	500ns	$\leq 2.5\text{ns}$	$\leq 2.5\text{ns}$

SW00025

2.5 V/3.3 V 16-bit registered transceiver (3-State)

74ALVT16543

SSOP56: plastic shrink small outline package; 56 leads; body width 7.5 mm

SOT371-1

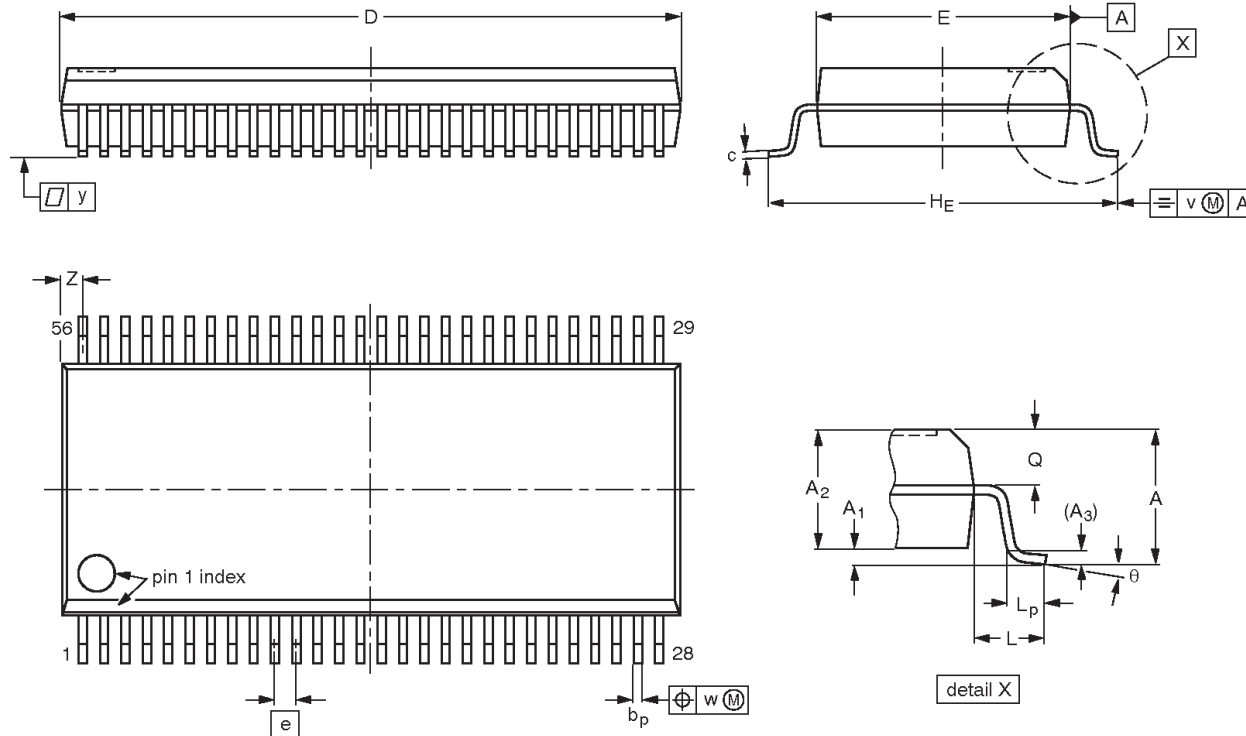

DIMENSIONS (mm are the original dimensions)

UNIT	A max.	A ₁	A ₂	A ₃	b _p	c	D ⁽¹⁾	E ⁽¹⁾	e	H _E	L	L _p	Q	v	w	y	Z ⁽¹⁾	θ
mm	2.8	0.4 0.2	2.35 2.20	0.25	0.3 0.2	0.22 0.13	18.55 18.30	7.6 7.4	0.635	10.4 10.1	1.4	1.0 0.6	1.2 1.0	0.25	0.18	0.1	0.85 0.40	8° 0°

Note

1. Plastic or metal protrusions of 0.25 mm maximum per side are not included.

OUTLINE VERSION	REFERENCES				EUROPEAN PROJECTION	ISSUE DATE
	IEC	JEDEC	JEITA			
SOT371-1		MO-118				99-12-27 03-02-18

2.5 V/3.3 V 16-bit registered transceiver (3-State)

74ALVT16543

TSSOP56: plastic thin shrink small outline package; 56 leads; body width 6.1 mm

SOT364-1

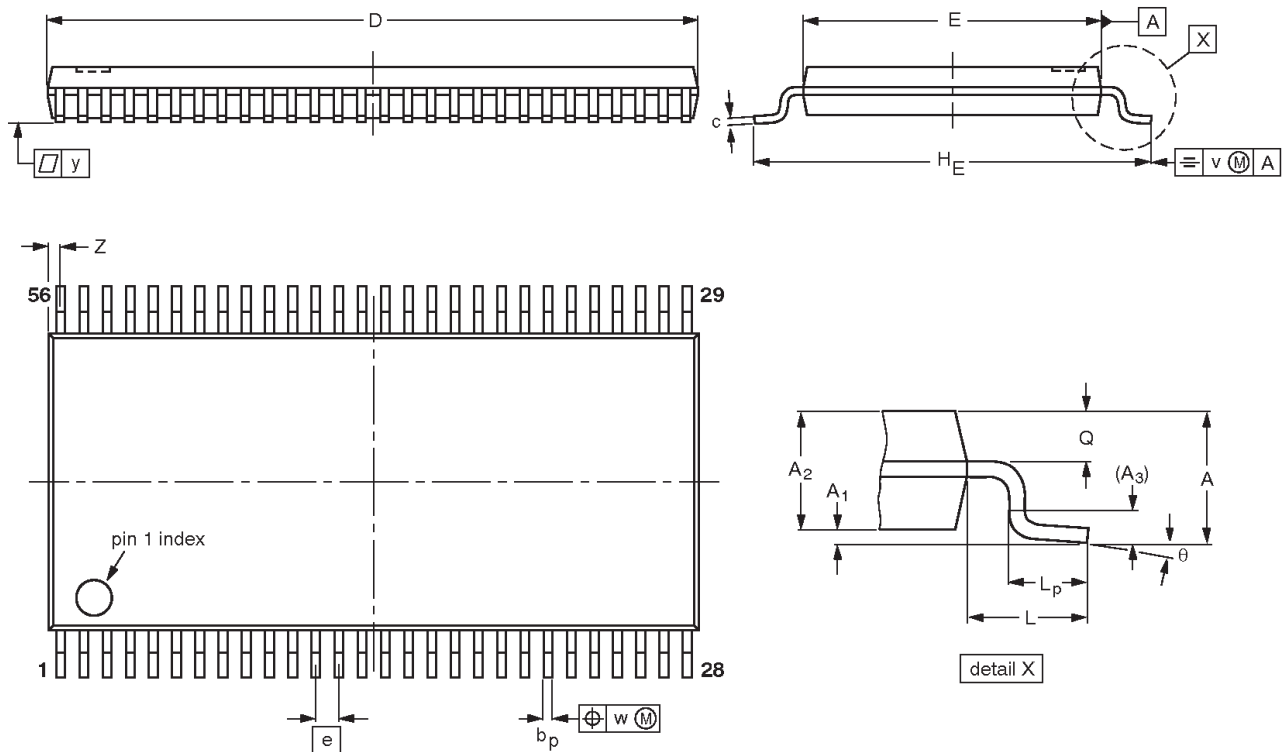

DIMENSIONS (mm are the original dimensions).

UNIT	A max.	A ₁	A ₂	A ₃	b _p	c	D ⁽¹⁾	E ⁽²⁾	e	H _E	L	L _p	Q	v	w	y	Z	θ
mm	1.2	0.15 0.05	1.05 0.85	0.25	0.28 0.17	0.2 0.1	14.1 13.9	6.2 6.0	0.5	8.3 7.9	1	0.8 0.4	0.50 0.35	0.25	0.08	0.1	0.5 0.1	8° 0°

Notes

1. Plastic or metal protrusions of 0.15 mm maximum per side are not included.
2. Plastic interlead protrusions of 0.25 mm maximum per side are not included.

OUTLINE VERSION	REFERENCES				EUROPEAN PROJECTION	ISSUE DATE
	IEC	JEDEC	JEITA			
SOT364-1		MO-153				-99-12-27 03-02-19

2.5 V/3.3 V 16-bit registered transceiver (3-State)

74ALVT16543

REVISION HISTORY

Rev	Date	Description
_3	20040914	<p>Product data sheet (9397 750 14059). Supersedes data of 1998 Feb 13 (9397 750 03568).</p> <p>Modifications:</p> <ul style="list-style-type: none"> ● Ordering information table on page 2: <ul style="list-style-type: none"> – remove “North America” column; rename third column from “Outside North America” to “Type Number”. ● DC Electrical Characteristics (3.3 V ± 0.3 V range) table on page 6: <ul style="list-style-type: none"> – I_I on Data pins: add condition ‘V_{CC} = 3.6 V; V_I = 5.5 V’ and values 0.1 μA (typ) and 20 μA (max). ● AC Characteristics (3.3 V ± 0.3 V range) table on page 8: <ul style="list-style-type: none"> – change propagation delay nAx to nBx t_{PLH} Max. time from 2.5 ns to 2.6 ns – change output disable time nOEBA to nAx, nOEAB to nBx t_{PHZ} (Max.) time from 4.7 ns to 4.8 ns – change output disable time nOEB̄A to nAx, nOEB̄AB to nBx t_{PLZ} (Max.) time from 4.0 ns to 4.2 ns – change output disable time nEB̄A to nAx, nEB̄AB to nBx t_{PHZ} (Max.) time from 4.5 ns to 4.9 ns – change output disable time nEB̄BA to nAx, nEB̄BAB to nBx t_{PLZ} (Max.) time from 3.8 ns to 4.2 ns ● AC Setup Requirements (3.3 V ± 0.3 V range) table on page 8: <ul style="list-style-type: none"> – change setup time nAx to nLEAB, nBx to nLEBA t_s(H) (Min.) from 0.0 ns to 0.5 ns; (Typ.) from –0.8 ns to 0 ns – change setup time nAx to nLEAB, nBx to nLEBA t_s(L) (Typ.) from –0.3 ns to –0.4 ns – change hold time nAx to nLEAB, nBx to nLEBA t_h(H) (Typ.) from 0.4 ns to 0.2 ns – change hold time nAx to nLEAB, nBx to nLEBA t_h(L) (Typ.) from 0.8 ns to –0.3 ns – change setup time nAx to nEAB, nBx to nEBA t_s(H) (Typ.) from –0.8 ns to –0.3 ns – change setup time nAx to nEAB, nBx to nEBA t_s(L) (Typ.) from –0.2 ns to –0.6 ns – change hold time nAx to nEAB, nBx to nEBA t_h(H) (Typ.) from 0.3 ns to 0.6 ns – change hold time nAx to nEAB, nBx to nEBA t_h(L) (Typ.) from 1.1 ns to 0.1 ns ● AC Setup Requirements (2.5 V ± 0.2 V range) table on page 9: <ul style="list-style-type: none"> – change setup time nAx to nLEAB, nBx to nLEBA t_s(H) (Min.) from 0 ns to 0.5 ns; (Typ.) from –0.9 ns to –0.2 ns – change setup time nAx to nLEAB, nBx to nLEBA t_s(L) (Typ.) from 0.2 ns to –0.5 ns – change hold time nAx to nLEAB, nBx to nLEBA t_h(H) (Min.) from 0.8 ns to 1.0 ns; (Typ.) from –0.2 ns to 0.2 ns – change hold time nAx to nLEAB, nBx to nLEBA t_h(L) (Min.) from 1.7 ns to 1.0 ns; (Typ.) from 1.0 ns to –0.2 ns – change setup time nAx to nEAB, nBx to nEBA t_s(H) (Min.) from 0 ns to 0.5 ns; (Typ.) from –1.0 ns to –0.3 ns – change setup time nAx to nEAB, nBx to nEBA t_s(L) (Typ.) from 0.4 ns to –0.6 ns – change hold time nAx to nEAB, nBx to nEBA t_h(H) (Min.) from 0.5 ns to 1.2 ns; (Typ.) from 0.2 ns to 0 ns – change hold time nAx to nEAB, nBx to nEBA t_h(L) (Min.) from 2.0 ns to 1.5 ns; (Typ.) from 1.3 ns to 0.2 ns
_2	19980213	<p>Product specification (9397 750 03568). ECN 853-1823 18958 of 13 February 1998.</p> <p>Supersedes data of 1995 Dec 21.</p>
_1	19951221	

2.5 V/3.3 V 16-bit registered transceiver (3-State)

74ALVT16543

Data sheet status

Level	Data sheet status ^[1]	Product status ^{[2] [3]}	Definitions
I	Objective data sheet	Development	This data sheet contains data from the objective specification for product development. Philips Semiconductors reserves the right to change the specification in any manner without notice.
II	Preliminary data sheet	Qualification	This data sheet contains data from the preliminary specification. Supplementary data will be published at a later date. Philips Semiconductors reserves the right to change the specification without notice, in order to improve the design and supply the best possible product.
III	Product data sheet	Production	This data sheet contains data from the product specification. Philips Semiconductors reserves the right to make changes at any time in order to improve the design, manufacturing and supply. Relevant changes will be communicated via a Customer Product/Process Change Notification (CPCN).

[1] Please consult the most recently issued data sheet before initiating or completing a design.

[2] The product status of the device(s) described in this data sheet may have changed since this data sheet was published. The latest information is available on the Internet at URL <http://www.semiconductors.philips.com>.

[3] For data sheets describing multiple type numbers, the highest-level product status determines the data sheet status.

Definitions

Short-form specification — The data in a short-form specification is extracted from a full data sheet with the same type number and title. For detailed information see the relevant data sheet or data handbook.

Limiting values definition — Limiting values given are in accordance with the Absolute Maximum Rating System (IEC 60134). Stress above one or more of the limiting values may cause permanent damage to the device. These are stress ratings only and operation of the device at these or at any other conditions above those given in the Characteristics sections of the specification is not implied. Exposure to limiting values for extended periods may affect device reliability.

Application information — Applications that are described herein for any of these products are for illustrative purposes only. Philips Semiconductors make no representation or warranty that such applications will be suitable for the specified use without further testing or modification.

Disclaimers

Life support — These products are not designed for use in life support appliances, devices, or systems where malfunction of these products can reasonably be expected to result in personal injury. Philips Semiconductors customers using or selling these products for use in such applications do so at their own risk and agree to fully indemnify Philips Semiconductors for any damages resulting from such application.

Right to make changes — Philips Semiconductors reserves the right to make changes in the products—including circuits, standard cells, and/or software—described or contained herein in order to improve design and/or performance. When the product is in full production (status 'Production'), relevant changes will be communicated via a Customer Product/Process Change Notification (CPCN). Philips Semiconductors assumes no responsibility or liability for the use of any of these products, conveys no license or title under any patent, copyright, or mask work right to these products, and makes no representations or warranties that these products are free from patent, copyright, or mask work right infringement, unless otherwise specified.

Contact information

For additional information please visit
<http://www.semiconductors.philips.com>. Fax: +31 40 27 24825

© Koninklijke Philips Electronics N.V. 2004
 All rights reserved. Published in the U.S.A.

Date of release: 09-04

For sales offices addresses send e-mail to:
sales.addresses@www.semiconductors.philips.com

Document number:

9397 750 14059

Let's make things better.

X-ON Electronics

Largest Supplier of Electrical and Electronic Components

Click to view similar products for [Translation - Voltage Levels](#) category:

Click to view products by [NXP](#) manufacturer:

Other Similar products are found below :

[NLJVHC1GT08DFT2G](#) [NLSX4373DMR2G](#) [NLSX5012MUTAG](#) [HV583GA-G](#) [MC10H641FNR2G](#) [NLSX0102FCT1G](#) [NLSX0102FCT2G](#)
[NLSX4302EBMUTCG](#) [NLVSX4373DR2G](#) [PCA9306FMUTAG](#) [SY10H351JZ](#) [MC100EPT622MNG](#) [MAX9376EUB+T](#) [MAX9374AEKA+T](#)
[MAX3378EETD+](#) [MAX34405BEZT+](#) [NLSX3014MUTAG](#) [NVT4556BUKZ](#) [NLSV4T244EMUTAG](#) [NLSX5011MUTCG](#) [NLV9306USG](#)
[NLVSX4014MUTAG](#) [MAX34405BEZT+T](#) [NLSV4T3144MUTAG](#) [NSV12200LT1G](#) [NLVSX4373MUTAG](#) [NB3U23CMNTAG](#)
[MAX3371ELT+T](#) [MAX3008EUP+T](#) [NLVPCA9306AMUTCG](#) [NLSX3013BFCT1G](#) [MAX9378EUA+T](#) [NLV7WBD3125USG](#)
[NLV14504BDTG](#) [NLSX3012DMR2G](#) [NLSX5012DR2G](#) [MAX3391EEUD+T](#) [MAX3379EETD+](#) [PI4ULS3V4857GEAEX](#)
[MAX3391EEBC+T](#) [MAX14842ATE+T](#) [74AVCH1T45FZ4-7](#) [CLVC16T245MDGGREP](#) [HEF4104BT](#) [TC74LCX16245\(EL,F\)](#)
[MC10H124FNG](#) [CAVCB164245MDGGREP](#) [7WBD383USG](#) [NVT2001GM,115](#) [CLVC8T245MRHLTEP](#)