

DATA SHEET

For a complete data sheet, please also download:

- The IC06 74HC/HCT/HCU/HCMOS Logic Family Specifications
- The IC06 74HC/HCT/HCU/HCMOS Logic Package Information
- The IC06 74HC/HCT/HCU/HCMOS Logic Package Outlines

74HC/HCT4514

**4-to-16 line decoder/demultiplexer
with input latches**

Product specification
File under Integrated Circuits, IC06

September 1993

4-to-16 line decoder/demultiplexer with input latches

74HC/HCT4514

FEATURES

- Non-inverting outputs
- Output capability: standard
- I_{CC} category: MSI

GENERAL DESCRIPTION

The 74HC/HCT4514 are high-speed Si-gate CMOS devices and are pin compatible with "4514" of the "4000B" series. They are specified in compliance with JEDEC standard no. 7A.

The 74HC/HCT4514 are 4-to-16 line decoders/demultiplexers having four binary weighted address inputs (A₀ to A₃), with latches, a latch enable input (LE), and an active LOW enable input (\bar{E}). The 16 outputs (Q₀ to Q₁₅) are mutually exclusive active HIGH. When LE is HIGH, the selected output is determined by the data on A_n. When LE goes LOW, the last data present at A_n are stored in the latches and the outputs remain stable. When \bar{E} is LOW, the selected output, determined by the contents of the latch, is HIGH. At \bar{E} HIGH, all outputs are LOW. The enable input (\bar{E}) does not affect the state of the latch.

When the "4514" is used as a demultiplexer, \bar{E} is the data input and A₀ to A₃ are the address inputs.

QUICK REFERENCE DATA

GND = 0 V; T_{amb} = 25 °C; t_r = t_f = 6 ns

SYMBOL	PARAMETER	CONDITIONS	TYPICAL		UNIT
			HC	HCT	
t _{PHL} / t _{PLH}	propagation delay A _n to Q _n	C _L = 15 pF; V _{CC} = 5 V	23	26	ns
C _I	input capacitance		3.5	3.5	pF
C _{PD}	power dissipation capacitance per package	notes 1 and 2	44	45	pF

Notes

1. C_{PD} is used to determine the dynamic power dissipation (P_D in μW):

$$P_D = C_{PD} \times V_{CC}^2 \times f_i + \sum (C_L \times V_{CC}^2 \times f_o) \text{ where:}$$

f_i = input frequency in MHz

f_o = output frequency in MHz

∑ (C_L × V_{CC}² × f_o) = sum of outputs

C_L = output load capacitance in pF

V_{CC} = supply voltage in V

2. For HC the condition is V_I = GND to V_{CC}
For HCT the condition is V_I = GND to V_{CC} – 1.5 V

ORDERING INFORMATION

See "74HC/HCT/HCU/HCMOS Logic Package Information".

4-to-16 line decoder/demultiplexer with input latches

74HC/HCT4514

PIN DESCRIPTION

PIN NO.	SYMBOL	NAME AND FUNCTION
1	LE	latch enable input (active HIGH)
2, 3, 21, 22	A ₀ to A ₃	address inputs
11, 9, 10, 8, 7, 6, 5, 4, 18, 17, 20, 19, 14, 13, 16, 15	Q ₀ to Q ₁₅	multiplexer outputs (active HIGH)
12	GND	ground (0 V)
23	\bar{E}	enable input (active LOW)
24	V _{CC}	positive supply voltage

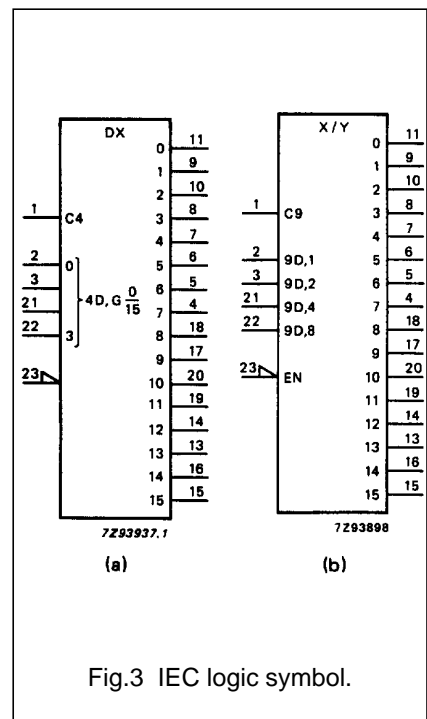
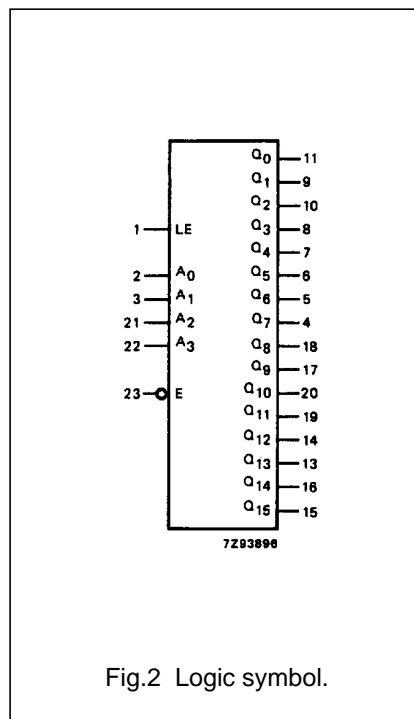
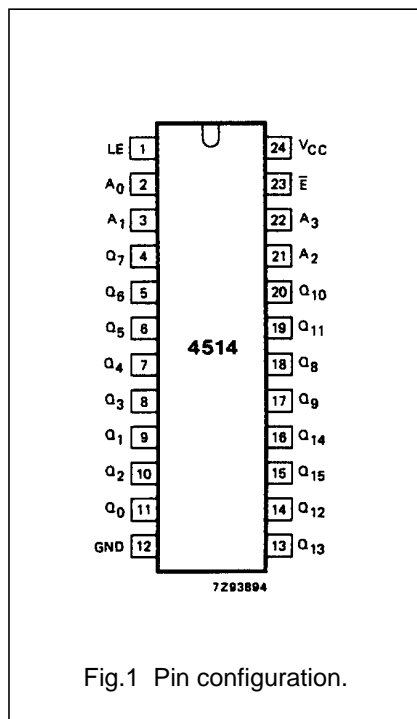

4-to-16 line decoder/demultiplexer with input latches

74HC/HCT4514

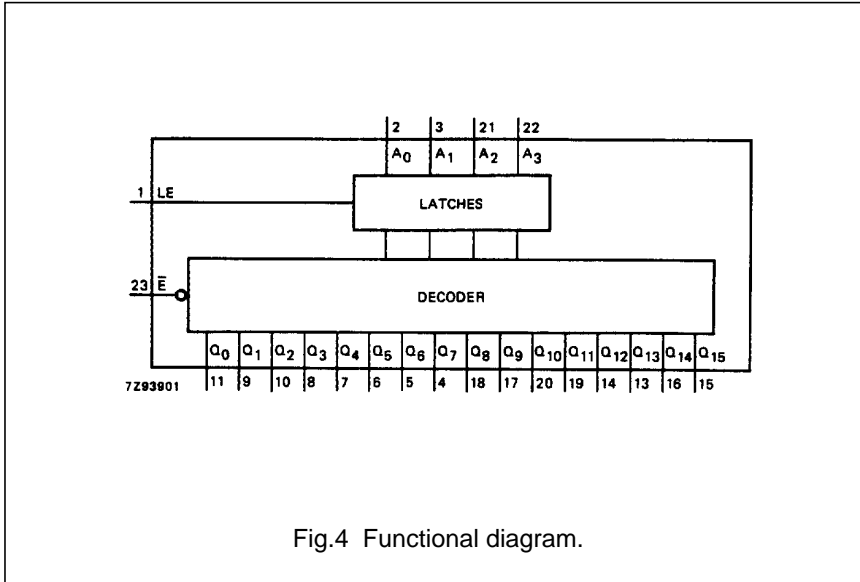

APPLICATIONS

- Digital multiplexing
- Address decoding
- Hexadecimal/BCD decoding

Fig.4 Functional diagram.

FUNCTION TABLE

INPUTS					OUTPUTS																
\bar{E}	A ₀	A ₁	A ₂	A ₃	Q ₀	Q ₁	Q ₂	Q ₃	Q ₄	Q ₅	Q ₆	Q ₇	Q ₈	Q ₉	Q ₁₀	Q ₁₁	Q ₁₂	Q ₁₃	Q ₁₄	Q ₁₅	
H	X	X	X	X	L	L	L	L	L	L	L	L	L	L	L	L	L	L	L	L	L
L	L	L	L	L	H	L	L	L	L	L	L	L	L	L	L	L	L	L	L	L	L
L	L	L	L	L	L	H	L	L	L	L	L	L	L	L	L	L	L	L	L	L	L
L	L	L	L	L	L	L	H	L	L	L	L	L	L	L	L	L	L	L	L	L	L
L	L	L	L	L	L	L	L	H	L	L	L	L	L	L	L	L	L	L	L	L	L
L	L	L	L	L	L	L	L	L	H	L	L	L	L	L	L	L	L	L	L	L	L
L	L	L	L	L	L	L	L	L	L	H	L	L	L	L	L	L	L	L	L	L	L
L	L	L	L	L	L	L	L	L	L	L	H	L	L	L	L	L	L	L	L	L	L
L	L	L	L	L	L	L	L	L	L	L	L	H	L	L	L	L	L	L	L	L	L
L	L	L	L	L	L	L	L	L	L	L	L	L	H	L	L	L	L	L	L	L	L
L	L	L	L	L	L	L	L	L	L	L	L	L	L	H	L	L	L	L	L	L	L
L	L	L	L	L	L	L	L	L	L	L	L	L	L	L	H	L	L	L	L	L	L
L	L	L	L	L	L	L	L	L	L	L	L	L	L	L	L	H	L	L	L	L	L
L	L	L	L	L	L	L	L	L	L	L	L	L	L	L	L	L	H	L	L	L	L
L	L	L	L	L	L	L	L	L	L	L	L	L	L	L	L	L	L	H	L	L	L
L	L	L	L	L	L	L	L	L	L	L	L	L	L	L	L	L	L	L	H	L	L
L	L	L	L	L	L	L	L	L	L	L	L	L	L	L	L	L	L	L	L	H	L

Notes

1. LE = HIGH
 H = HIGH voltage level
 L = LOW voltage level
 X = don't care

4-to-16 line decoder/demultiplexer with input latches

74HC/HCT4514

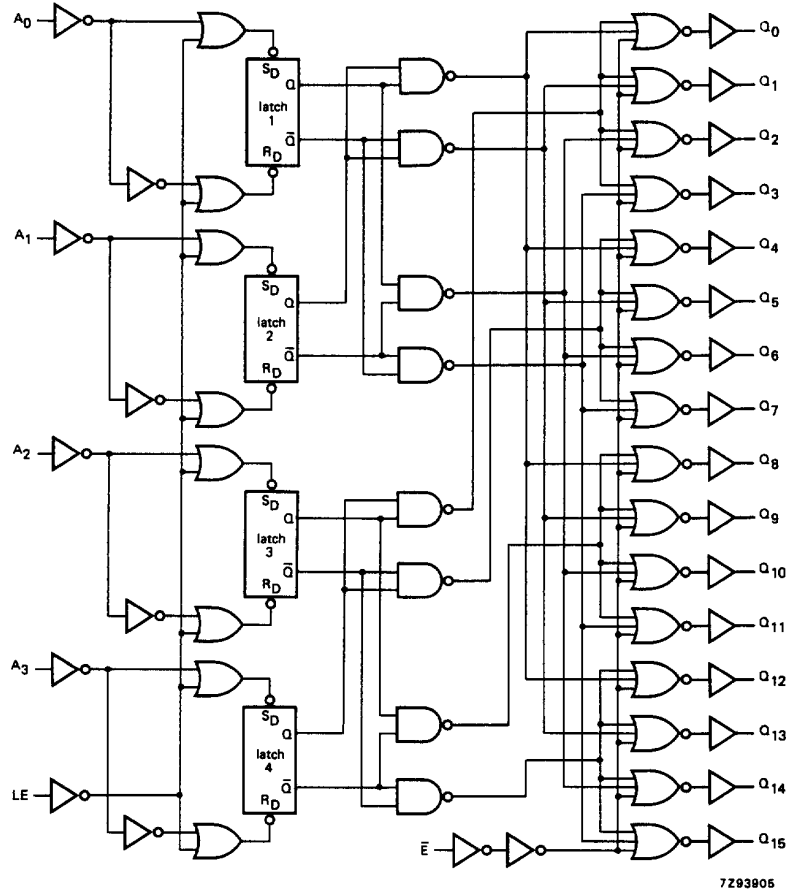

Fig.5 Logic diagram.

4-to-16 line decoder/demultiplexer with input latches

74HC/HCT4514

DC CHARACTERISTICS FOR 74HC

For the DC characteristics see *"74HC/HCT/HCU/HCMOS Logic Family Specifications"*.

Output capability: standard

I_{CC} category: MSI

AC CHARACTERISTICS FOR 74HC

GND = 0 V; t_r = t_f = 6 ns; C_L = 50 pF

SYMBOL	PARAMETER	T _{amb} (°C)						UNIT	TEST CONDITIONS		
		74HC							V _{CC} (V)	WAVEFORMS	
		+25			-40 to +85		-40 to +125				
		min.	typ.	max.	min.	max.	min.				max.
t _{PHL} / t _{PLH}	propagation delay A _n to Q _n		74 27 22	230 46 39		290 58 49		345 69 59	ns	2.0 4.5 6.0	Fig.6
t _{PHL} / t _{PLH}	propagation delay LE to Q _n		74 27 22	230 46 39		290 58 49		345 69 59	ns	2.0 4.5 6.0	Fig.6
t _{PHL} / t _{PLH}	propagation delay \bar{E} to Q _n		41 15 12	175 35 30		220 44 37		265 53 45	ns	2.0 4.5 6.0	Fig.6
t _{THL} / t _{TLH}	output transition time		19 7 6	75 15 13		95 19 16		110 22 19	ns	2.0 4.5 6.0	Fig.6
t _W	latch enable pulse width HIGH	80 16 14	14 5 4		100 20 17		120 24 20		ns	2.0 4.5 6.0	Fig.7
t _{SU}	set-up time A _n to LE	90 18 15	25 9 7		115 23 20		135 27 23		ns	2.0 4.5 6.0	Fig.7
t _H	hold time A _n to LE	1 1 1	-11 -4 -3		1 1 1		1 1 1		ns	2.0 4.5 6.0	Fig.7

4-to-16 line decoder/demultiplexer with input latches

74HC/HCT4514

DC CHARACTERISTICS FOR 74HCT

For the DC characteristics see *"74HC/HCT/HCU/HCMOS Logic Family Specifications"*.

Output capability: standard

I_{CC} category: MSI

Note to HCT types

The value of additional quiescent supply current (ΔI_{CC}) for a unit load of 1 is given in the family specifications.

To determine ΔI_{CC} per input, multiply this value by the unit load coefficient shown in the table below.

INPUT	UNIT LOAD COEFFICIENT
A _n	0.65
LE	1.40
\bar{E}	1.00

AC CHARACTERISTICS FOR 74HCT

GND = 0 V; t_r = t_f = 6 ns; C_L = 50 pF

SYMBOL	PARAMETER	T _{amb} (°C)							UNIT	TEST CONDITIONS	
		74HCT								V _{CC} (V)	WAVEFORMS
		+25			-40 to +85		-40 to +125				
		min.	typ.	max.	min.	max.	min.	max.			
t _{PHL} / t _{PLH}	propagation delay A _n to Q _n		30	55		69		83	ns	4.5	Fig.6
t _{PHL} / t _{PLH}	propagation delay LE to Q _n		29	50		63		75	ns	4.5	Fig.6
t _{PHL} / t _{PLH}	propagation delay \bar{E} to Q _n		17	40		50		60	ns	4.5	Fig.6
t _{THL} / t _{TLH}	output transition time		7	15		19		22	ns	4.5	Fig.6
t _w	latch enable pulse width HIGH	16	4		20		24		ns	4.5	Fig.7
t _{su}	set-up time A _n to LE	18	9		23		27		ns	4.5	Fig.7
t _h	hold time A _n to LE	3	-3		3		3		ns	4.5	Fig.7

4-to-16 line decoder/demultiplexer with input latches

74HC/HCT4514

AC WAVEFORMS

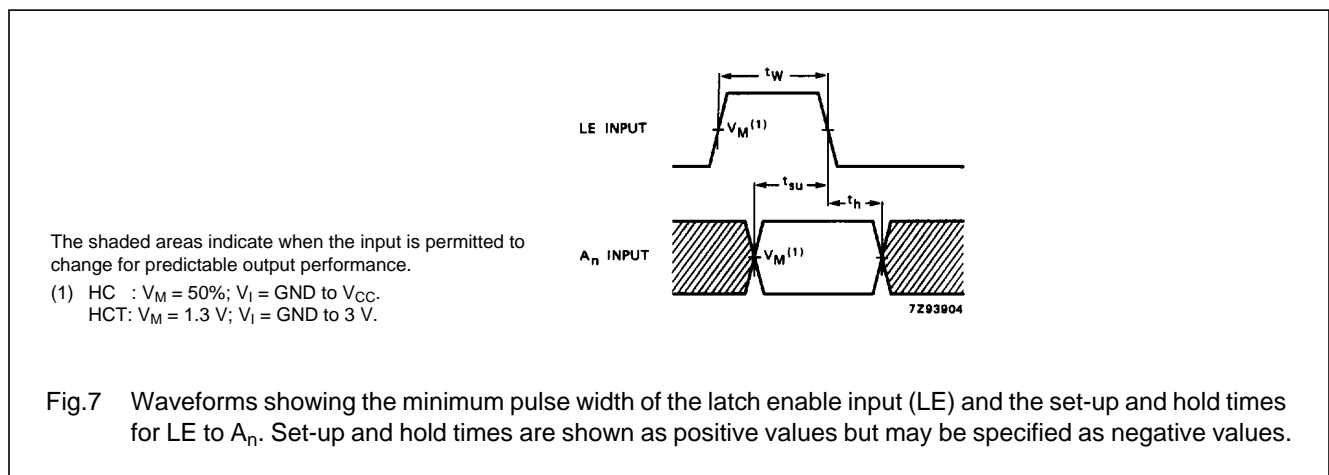
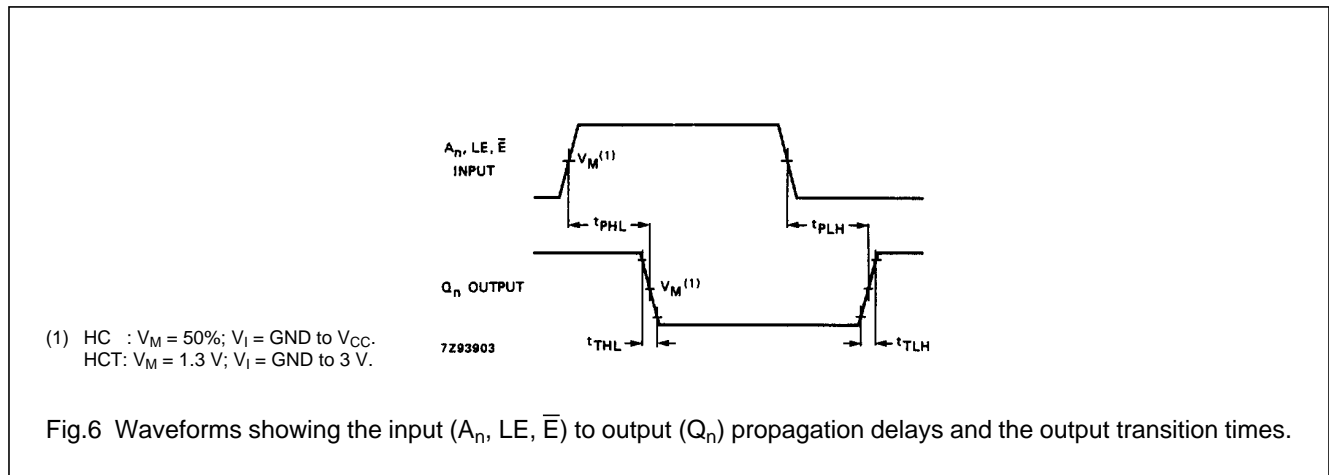

4-to-16 line decoder/demultiplexer with input latches

74HC/HCT4514

APPLICATION INFORMATION

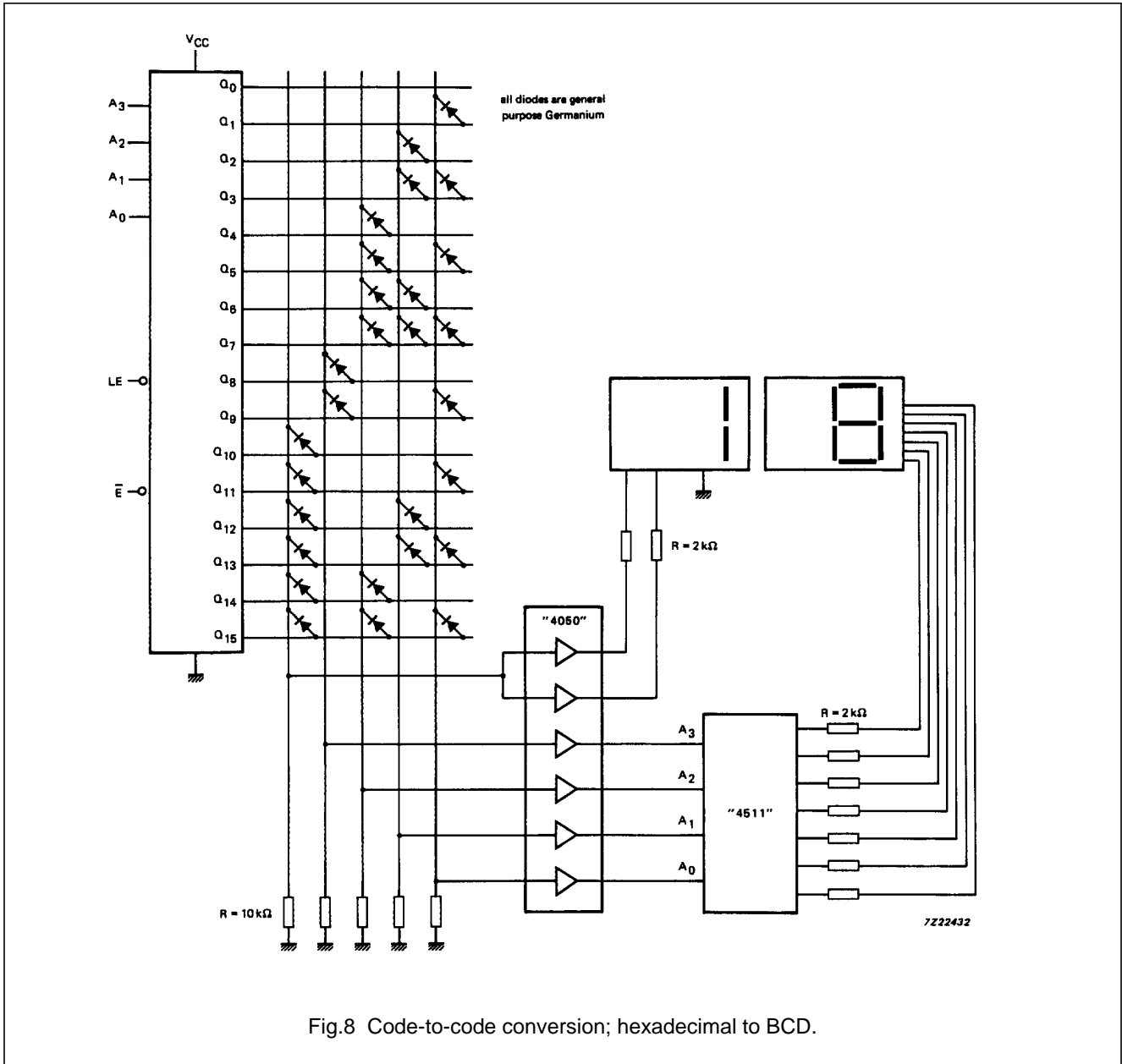

Fig.8 Code-to-code conversion; hexadecimal to BCD.

PACKAGE OUTLINES

See "74HC/HCT/HCU/HCMOS Logic Package Outlines".

X-ON Electronics

Largest Supplier of Electrical and Electronic Components

Click to view similar products for [Encoders, Decoders, Multiplexers & Demultiplexers](#) category:

Click to view products by [NXP](#) manufacturer:

Other Similar products are found below :

[M38510/01406BEA](#) [MC74HC163ADTG](#) [74HC253N](#) [NLV74VHC1G01DFT1G](#) [NLVHC4851ADTR2G](#) [NLVHCT4851ADTR2G](#)
[PI3B33X257BE](#) [M74HCT4052ADTR2G](#) [TC74AC138P\(F\)](#) [MC74LVX4051MNTWG](#) [NLV14051BDR2G](#) [NLV74HC238ADTR2G](#) [715428X](#)
[COMX-CAR-210](#) [5962-8607001EA](#) [MAX3783UCM+D](#) [PI5C3253QEX](#) [8CA3052APGGI8](#) [TC74HC4051AF\(EL,F\)](#) [TC74VHC138F\(EL,K,F\)](#)
[PI3B3251LE](#) [PI5C3251QEX](#) [PI3B3251QE](#) [74VHC4052AFT\(BJ\)](#) [PI3PCIE3415AZHEX](#) [NLV74HC4851AMNTWG](#) [MC74LVX257DG](#)
[M74HC151YRM13TR](#) [M74HC151YTTR](#) [PI5USB31213XEAEX](#) [M74HCT4851ADWR2G](#) [XD74LS154](#) [AP4373AW5-7-01](#)
[MC74HC151ADTG](#) [QS3VH251QG8](#) [QS4A201QG](#) [HCS500-I/SM](#) [TC4066BP\(N,F\)](#) [74ACT11139PWR](#) [74VHC238FT\(BJ\)](#)
[74VHC4066AFT\(BJ\)](#) [74VHCT138AFT\(BJ\)](#) [74HC158D.652](#) [74HC4052D\(BJ\)](#) [74VHC138MTC](#) [COMX-CAR-P1](#) [JM38510/36001BEA](#)
[JM38510/30702BEA](#) [PI3USB302-AZBEX](#) [PI5C3257LE](#)