

# DATA SHEET

For a complete data sheet, please also download:

- The IC06 74HC/HCT/HCU/HCMOS Logic Family Specifications
- The IC06 74HC/HCT/HCU/HCMOS Logic Package Information
- The IC06 74HC/HCT/HCU/HCMOS Logic Package Outlines

## **74HC/HCT221**

**Dual non-retriggerable monostable  
multivibrator with reset**

Product specification  
Supersedes data of April 1988  
File under Integrated Circuits, IC06

December 1990

## Dual non-retriggerable monostable multivibrator with reset

74HC/HCT221

### FEATURES

- Pulse width variance is typically less than  $\pm 5\%$
- Pin-out identical to "123"
- Overriding reset terminates output pulse
- nB inputs have hysteresis for improved noise immunity
- Output capability: standard (except for nR<sub>EXT</sub>/C<sub>EXT</sub>)
- I<sub>CC</sub> category: MSI

### GENERAL DESCRIPTION

The 74HC/HCT221 are high-speed Si-gate CMOS devices and are pin compatible with low power Schottky TTL (LSTTL). They are specified in compliance with JEDEC standard no. 7A.

The 74HC/HCT221 are dual non-retriggerable monostable multivibrators. Each multivibrator features an active LOW-going edge input (n $\bar{A}$ ) and an active HIGH-going edge input (nB), either of which can be used as an enable input.

Pulse triggering occurs at a particular voltage level and is not directly related to the transition time of the input pulse. Schmitt-trigger input circuitry for the nB inputs allow

jitter-free triggering from inputs with slow transition rates, providing the circuit with excellent noise immunity.

Once triggered, the outputs (nQ, n $\bar{Q}$ ) are independent of further transitions of n $\bar{A}$  and nB inputs and are a function of the timing components. The output pulses can be terminated by the overriding active LOW reset inputs (n $\bar{R}_D$ ). Input pulses may be of any duration relative to the output pulse.

Pulse width stability is achieved through internal compensation and is virtually independent of V<sub>CC</sub> and temperature. In most applications pulse stability will only be limited by the accuracy of the external timing components.

The output pulse width is defined by the following relationship:

$$t_W = C_{EXT}R_{EXT} \ln 2$$

$$t_W = 0.7C_{EXT}R_{EXT}$$

Pin assignments for the "221" are identical to those of the "123" so that the "221" can be substituted for those products in systems not using the retrigger by merely changing the value of R<sub>EXT</sub> and/or C<sub>EXT</sub>.

### QUICK REFERENCE DATA

GND = 0 V; T<sub>amb</sub> = 25 °C; t<sub>r</sub> = t<sub>f</sub> = 6 ns

SYMBOL	PARAMETER	CONDITIONS	TYPICAL		UNIT
			HC	HCT	
t <sub>PHL</sub>	propagation delay n $\bar{A}$ , nB, n $\bar{R}_D$ to nQ, n $\bar{Q}$	C <sub>L</sub> = 15 pF; V <sub>CC</sub> = 5 V; R <sub>EXT</sub> = 5 k $\Omega$ ; C <sub>EXT</sub> = 0 pF	29	32	ns
t <sub>PLH</sub>	n $\bar{A}$ , nB, n $\bar{R}_D$ to nQ, n $\bar{Q}$		35	36	ns
C <sub>I</sub>	input capacitance		3.5	3.5	pF
C <sub>PD</sub>	power dissipation capacitance per package	notes 1 and 2	90	96	pF

### Notes

1. C<sub>PD</sub> is used to determine the dynamic power dissipation (P<sub>D</sub> in  $\mu$ W):

$$P_D = C_{PD} \times V_{CC}^2 \times f_i + \sum (C_L \times V_{CC}^2 \times f_o) + 0.33 \times C_{EXT} \times V_{CC}^2 \times f_o + D \times 28 \times V_{CC} \quad \text{where:}$$

f<sub>i</sub> = input frequency in MHz; f<sub>o</sub> = output frequency in MHz

$\sum (C_L \times V_{CC}^2 \times f_o)$  = sum of outputs

C<sub>EXT</sub> = timing capacitance in pF; C<sub>L</sub> = output load capacitance in pF

V<sub>CC</sub> = supply voltage in V; D = duty factor in %

2. For HC the condition is V<sub>I</sub> = GND to V<sub>CC</sub>  
For HCT the condition is V<sub>I</sub> = GND to V<sub>CC</sub> - 1.5 V

# Dual non-retriggerable monostable multivibrator with reset

74HC/HCT221

## ORDERING INFORMATION

See "74HC/HCT/HCU/HCMOS Logic Package Information".

## PIN DESCRIPTION

PIN NO.	SYMBOL	NAME AND FUNCTION
1, 9	$1\bar{A}, 2\bar{A}$	trigger inputs (negative-edge triggered)
2, 10	1B, 2B	trigger inputs (positive-edge triggered)
3, 11	$1\bar{R}_D, 2\bar{R}_D$	direct reset inputs (active LOW)
4, 12	$1\bar{Q}, 2\bar{Q}$	outputs (active LOW)
7	$2R_{EXT}/C_{EXT}$	external resistor/capacitor connection
8	GND	ground (0 V)
13, 5	1Q, 2Q	outputs (active HIGH)
14, 6	$1C_{EXT}, 2C_{EXT}$	external capacitor connection
15	$1R_{EXT}/C_{EXT}$	external resistor/capacitor connection
16	VCC	positive supply voltage

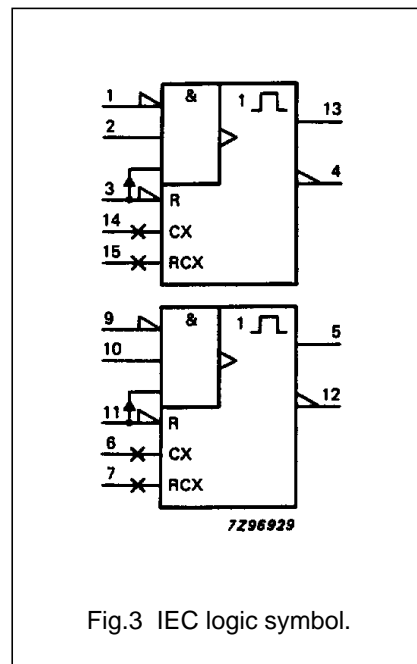
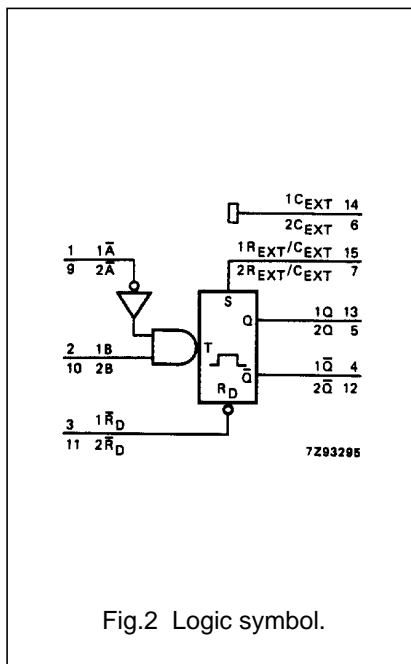
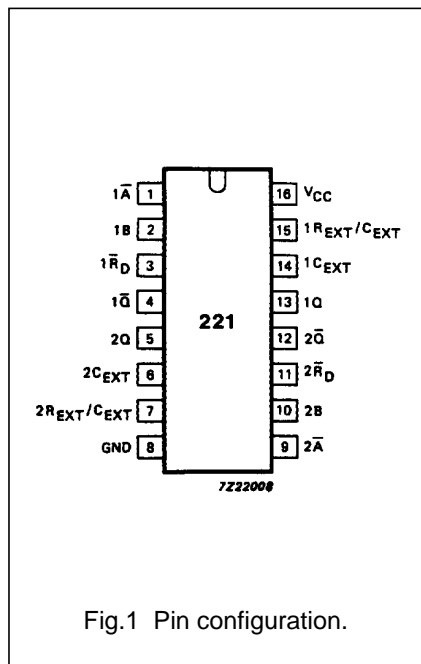

# Dual non-retriggerable monostable multivibrator with reset

74HC/HCT221

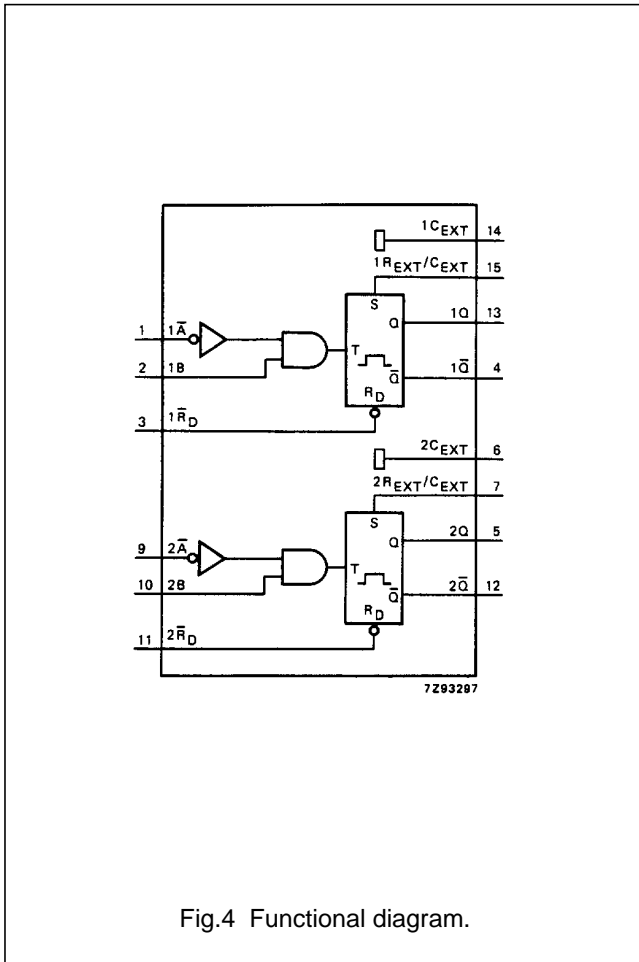

Fig.4 Functional diagram.

### FUNCTION TABLE

INPUTS			OUTPUTS	
$n\bar{R}_D$	$n\bar{A}$	$nB$	$nQ$	$n\bar{Q}$
L	X	X	L	H
X	H	X	L (2)	H (2)
X	X	L	L (2)	H (2)
H	L	↑		
H	↓	H		
↑	L	H		

### Notes

- H = HIGH voltage level  
L = LOW voltage level  
X = don't care  
↑ = LOW-to-HIGH level  
↓ = HIGH-to-LOW level  
 = one HIGH-level output pulse  
 = one LOW-level output pulse
- If the monostable was triggered before this condition was established the pulse will continue as programmed.
- For this combination the reset input must be LOW and the following sequence must be used:  
pin 1 (or 9) must be set HIGH or pin 2 (or 10) set LOW;  
then pin 1 (or 9) must be LOW and pin 2 (or 10) set HIGH. Now the reset input goes from LOW-to-HIGH and the device will be triggered.

# Dual non-retriggerable monostable multivibrator with reset

## 74HC/HCT221

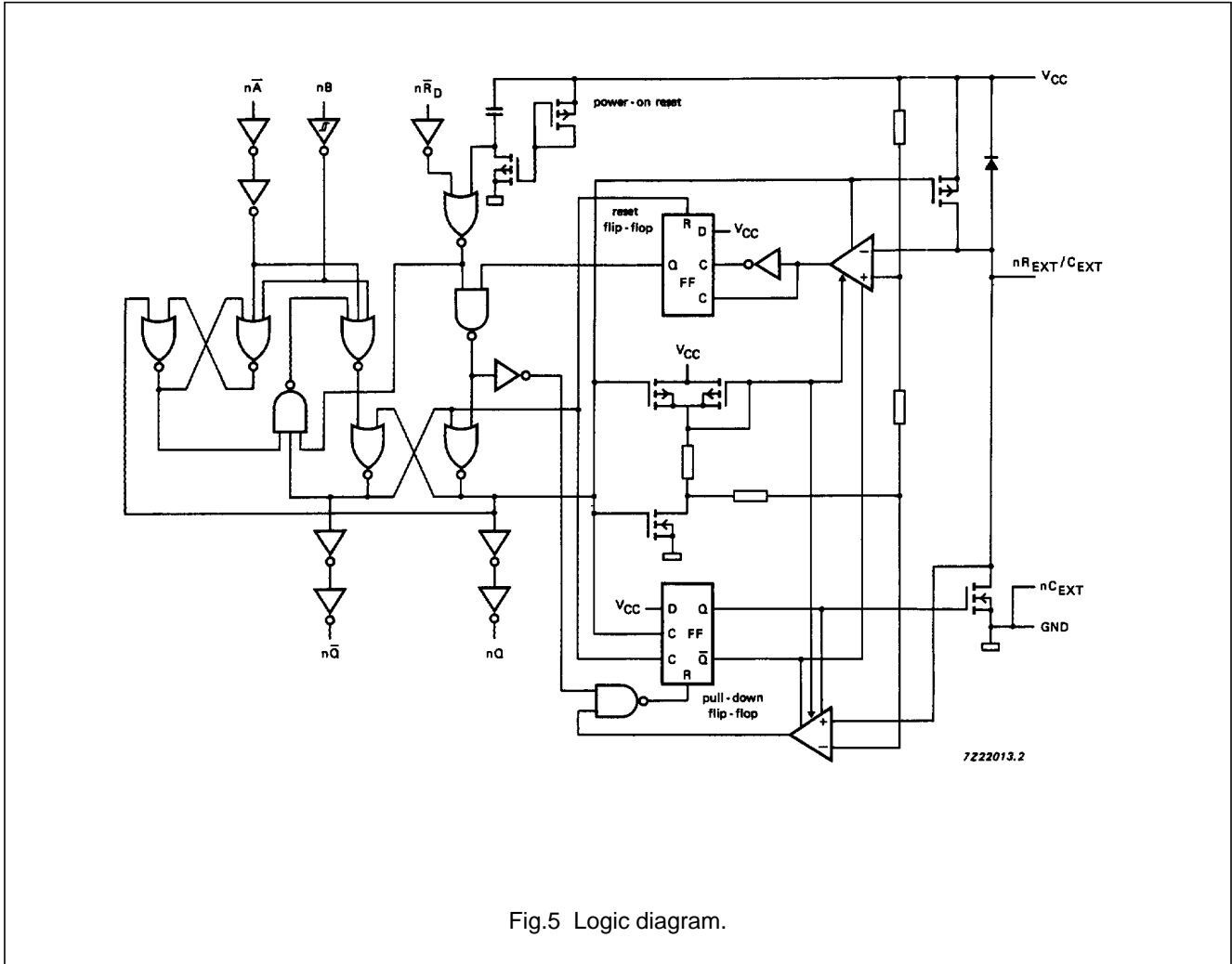

**Note**

It is recommended to ground pins 6 (2C<sub>EXT</sub>) and 14 (1C<sub>EXT</sub>) externally to pin 8 (GND).

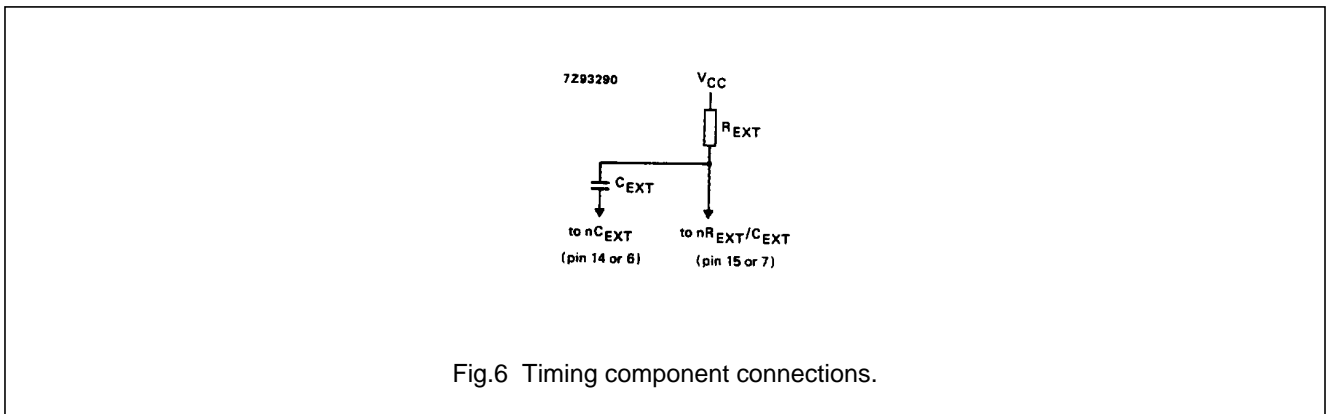

# Dual non-retriggerable monostable multivibrator with reset

74HC/HCT221

## DC CHARACTERISTICS FOR 74HC

For the DC characteristics see *"74HC/HCT/HCU/HCMOS Logic Family Specifications"*.

Output capability: standard (except for nR<sub>EXT</sub>/C<sub>EXT</sub>)

I<sub>CC</sub> category: MSI

## AC CHARACTERISTICS FOR 74HC

GND = 0 V; t<sub>r</sub> = t<sub>f</sub> = 6 ns; C<sub>L</sub> = 50 pF

SYMBOL	PARAMETER	T <sub>amb</sub> (°C)							UNIT	TEST CONDITIONS	
		74HC								V <sub>CC</sub> (V)	WAVEFORMS
		+25			-40 to +85		-40 to +125				
		min	typ	max.	min	max.	min.	max.			
t <sub>PLH</sub>	propagation delay (trigger) nA, nB to nQ	72	220		275		330	ns	2.0 4.5 6.0	C <sub>EXT</sub> = 0 pF; R <sub>EXT</sub> = 5 kΩ; Fig.10	
t <sub>PLH</sub>	propagation delay (trigger) nR <sub>D</sub> to nQ	80	245		305		370	ns	2.0 4.5 6.0	C <sub>EXT</sub> = 0 pF; R <sub>EXT</sub> = 5 kΩ; Fig.10	
t <sub>PHL</sub>	propagation delay (trigger) nA, nB to nQ̄	58	180		225		270	ns	2.0 4.5 6.0	C <sub>EXT</sub> = 0 pF; R <sub>EXT</sub> = 5 kΩ; Fig.10	
t <sub>PHL</sub>	propagation delay (trigger) nR <sub>D</sub> to nQ̄	63	195		245		295	ns	2.0 4.5 6.0	C <sub>EXT</sub> = 0 pF; R <sub>EXT</sub> = 5 kΩ; Fig.10	
t <sub>PLH</sub>	propagation delay (reset) nR <sub>D</sub> to nQ	66	200		250		300	ns	2.0 4.5 6.0	C <sub>EXT</sub> = 0 pF; R <sub>EXT</sub> = 5 kΩ; Fig.11	
t <sub>PLH</sub>	propagation delay (reset) nR <sub>D</sub> to nQ	58	180		225		270	ns	2.0 4.5 6.0	C <sub>EXT</sub> = 0 pF; R <sub>EXT</sub> = 5 kΩ; Fig.11	
t <sub>THL</sub> / t <sub>TLH</sub>	output transition time	19	75		95		110	ns	2.0 4.5 6.0	Fig.10	
t <sub>w</sub>	trigger pulse width nA = LOW	75 15 13	25 9 7		95 19 16		110 22 19	ns	2.0 4.5 6.0	Fig.7	
t <sub>w</sub>	trigger pulse width nB = HIGH	90 18 15	30 11 9		115 23 20		135 27 23	ns	2.0 4.5 6.0	Fig.7	
t <sub>w</sub>	trigger pulse width nR <sub>D</sub> = LOW	75 15 13	25 9 7		95 19 16		110 22 19	ns	2.0 4.5 6.0	Fig.8	
t <sub>w</sub>	output pulse width nQ̄ = LOW nQ = HIGH	630	700	770	602	798	595	805	μs	5.0	C <sub>EXT</sub> = 100 nF; R <sub>EXT</sub> = 10 kΩ; Fig.10

Dual non-retriggerable monostable  
multivibrator with reset

74HC/HCT221

SYMBOL	PARAMETER	T <sub>amb</sub> (°C)							UNIT	TEST CONDITIONS	
		74HC								V <sub>CC</sub> (V)	WAVEFORMS
		+25			-40 to +85		-40 to +125				
		min	typ	max.	min	max.	min.	max.			
t <sub>w</sub>	output pulse width nQ or nQ̄		140		–		–		ns	2.0 4.5 6.0	C <sub>EXT</sub> = 28 nF; R <sub>EXT</sub> = 2 kΩ; Fig.10
t <sub>w</sub>	output pulse width nQ or nQ̄		1.5		–		–		μs	2.0 4.5 6.0	C <sub>EXT</sub> = 1 nF; R <sub>EXT</sub> = 2 kΩ; Fig.10
t <sub>w</sub>	output pulse width nQ or nQ̄		7		–		–		μs	2.0 4.5 6.0	C <sub>EXT</sub> = 1 nF; R <sub>EXT</sub> = 10 kΩ; Fig.10
t <sub>w</sub>	pulse width match between circuits in the package		± 2		–		–		%	4.5 to 5.5	C <sub>EXT</sub> = 1000 pF; R <sub>EXT</sub> = 10 kΩ
t <sub>rem</sub>	removal time nR <sub>D</sub> to nĀ or nB	100 20 17	30 11 9		125 25 21		150 30 26		ns	2.0 4.5 6.0	Fig.9
R <sub>EXT</sub>	external timing resistor	10 2		1000 1000	– –		– –		kΩ	2.0 5.0	Fig.12 Fig.13
C <sub>EXT</sub>	external timing capacitor	no limits							pF	2.0 5.0	Fig.12 Fig.13

---

**Dual non-retriggerable monostable  
multivibrator with reset**

---

**74HC/HCT221****DC CHARACTERISTICS FOR 74HCT**

For the DC characteristics see *"74HC/HCT/HCU/HCMOS Logic Family Specifications"*.

Output capability: standard (except for nR<sub>EXT</sub>/C<sub>EXT</sub>)

I<sub>CC</sub> category: MSI

**Note to HCT types**

The value of additional quiescent supply current ( $\Delta I_{CC}$ ) for a unit load of 1 is given in the family specifications. To determine  $\Delta I_{CC}$  per input, multiply this value by the unit load coefficient shown in the table below.

INPUT	UNIT LOAD COEFFICIENT
nB	0.30
n $\bar{A}$	0.50
n $\bar{R}_D$	0.50



Dual non-retriggerable monostable  
multivibrator with reset

74HC/HCT221

## AC CHARACTERISTICS FOR 74HCT

GND = 0 V;  $t_r = t_f = 6$  ns;  $C_L = 50$  pF

SYMBOL	PARAMETER	$T_{amb}$ (°C)						UNIT	TEST CONDITIONS		
		74HCT							$V_{CC}$ (V)	WAVEFORMS	
		+25			-40 to +85		-40 to +125				
		min	typ	max	min	max.	min.				max.
$t_{PLH}$	propagation delay (trigger) $n\bar{A}$ , $n\bar{R}_D$ to $nQ$		30	50		63		75	ns	4.5	$C_{EXT} = 0$ pF; $R_{EXT} = 5$ k $\Omega$ ; Fig.10
$t_{PLH}$	propagation delay (trigger) $nB$ to $nQ$		24	42		53		63	ns	4.5	$C_{EXT} = 0$ pF; $R_{EXT} = 5$ k $\Omega$ ; Fig.10
$t_{PHL}$	propagation delay (trigger) $nA$ to $n\bar{Q}$		26	44		55		66	ns	4.5	$C_{EXT} = 0$ pF; $R_{EXT} = 5$ k $\Omega$ ; Fig.10
$t_{PHL}$	propagation delay (trigger) $nB$ to $n\bar{Q}$		21	35		44		53	ns	4.5	$C_{EXT} = 0$ pF; $R_{EXT} = 5$ k $\Omega$ ; Fig.10
$t_{PHL}$	propagation delay (trigger) $n\bar{R}_D$ to $n\bar{Q}$		26	43		54		65	ns	4.5	$C_{EXT} = 0$ pF; $R_{EXT} = 5$ k $\Omega$ ; Fig.10
$t_{PHL}$	propagation delay (reset) $n\bar{R}_D$ to $nQ$		26	43		54		65	ns	4.5	$C_{EXT} = 0$ pF; $R_{EXT} = 5$ k $\Omega$ ; Fig.11
$t_{PLH}$	propagation delay (reset) $n\bar{R}_D$ to $n\bar{Q}$		31	51		64		77	ns	4.5	$C_{EXT} = 0$ pF; $R_{EXT} = 5$ k $\Omega$ ; Fig.11
$t_{THL}/t_{TLH}$	output transition time		7	15		19		22	ns	4.5	Fig.10
$t_W$	trigger pulse width $nA = LOW$	20	13		25		30		ns	4.5	Fig.10
$t_W$	trigger pulse width $nB = HIGH$	20	13		25		30		ns	4.5	Fig.10
$t_W$	pulse width $n\bar{R}_D = LOW$	22	13		28		33		ns	4.5	Fig.8
$t_W$	output pulse width $n\bar{Q} = LOW$ $nQ = HIGH$	630	700	770	602	798	595	805	$\mu s$	5.0	$C_{EXT} = 100$ nF; $R_{EXT} = 10$ k $\Omega$ ; Fig.10
$t_W$	trigger pulse width $nQ$ or $n\bar{Q}$		140		–		–		ns	4.5	$C_{EXT} = 28$ pF; $R_{EXT} = 2$ k $\Omega$ ; Fig.10
$t_W$	trigger pulse width $nQ$ or $n\bar{Q}$		1.5		–		–		$\mu s$	4.5	$C_{EXT} = 1$ nF; $R_{EXT} = 2$ k $\Omega$ ; Fig.10

Dual non-retriggerable monostable  
multivibrator with reset

74HC/HCT221

SYMBOL	PARAMETER	T <sub>amb</sub> (°C)						UNIT	TEST CONDITIONS		
		74HCT							V <sub>CC</sub> (V)	WAVEFORMS	
		+25			-40 to +85		-40 to +125				
		min	typ	max	min	max.	min.				max.
t <sub>w</sub>	trigger pulse width nQ or nQ̄		7		–		–		μs	4.5	C <sub>EXT</sub> = 1 nF; R <sub>EXT</sub> = 10 kΩ; Fig.10
t <sub>rem</sub>	removal time nR <sub>D</sub> to nĀ or nB	20	12		25		30		ns	4.5	Fig.9
R <sub>EXT</sub>	external timing resistor	2		1000	–		–		kΩ	5.0	Fig.13
C <sub>EXT</sub>	external timing capacitor	no limits							pF	5.0	Fig.13

# Dual non-retriggerable monostable multivibrator with reset

74HC/HCT221

## AC WAVEFORMS

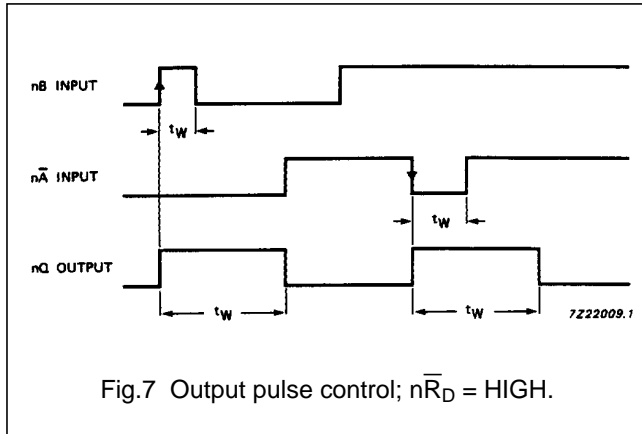

Fig.7 Output pulse control;  $\overline{nR}_D = \text{HIGH}$ .

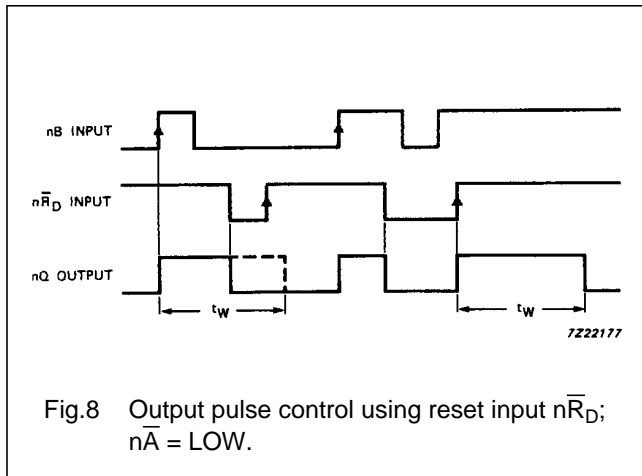
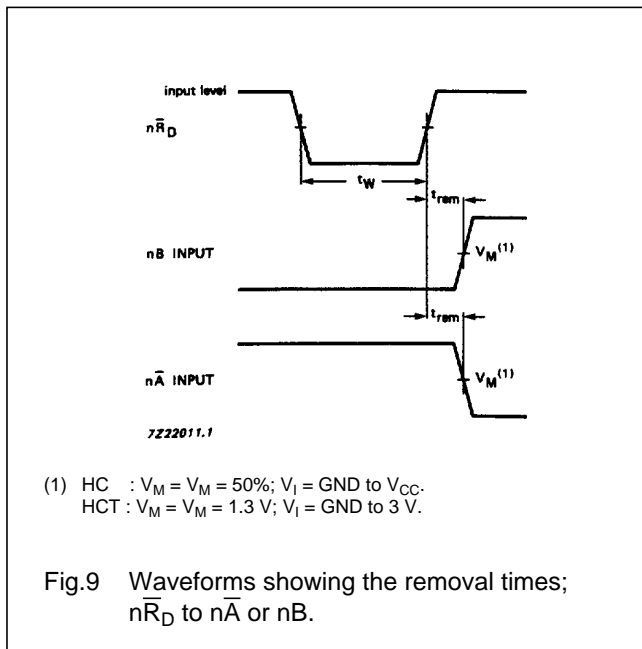
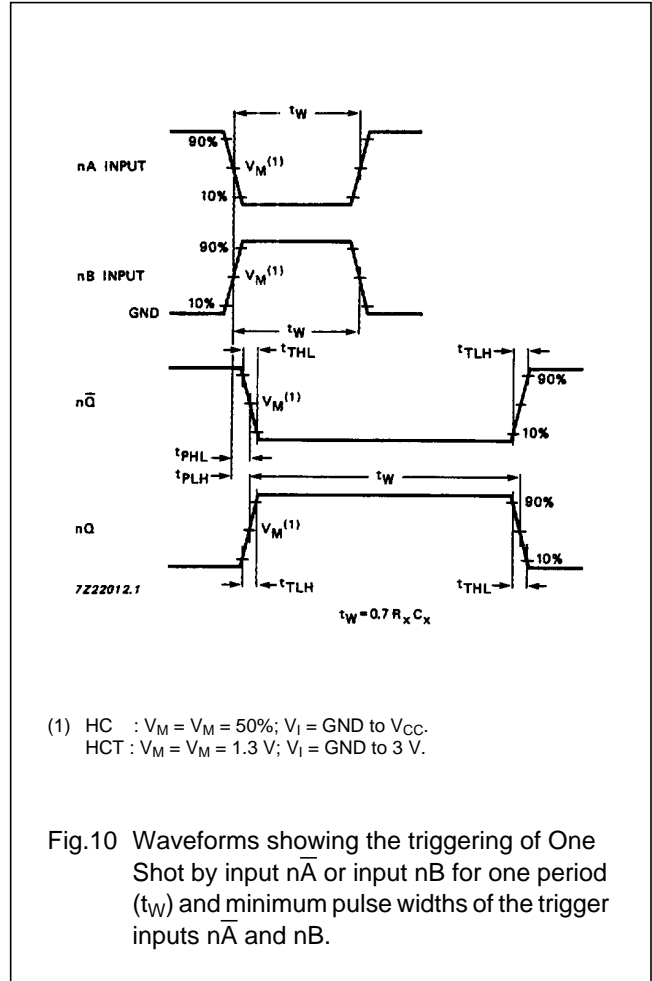

Fig.8 Output pulse control using reset input  $\overline{nR}_D$ ;  $nA = \text{LOW}$ .



(1) HC :  $V_M = V_M = 50\%$ ;  $V_I = \text{GND to } V_{CC}$ .  
HCT :  $V_M = V_M = 1.3 \text{ V}$ ;  $V_I = \text{GND to } 3 \text{ V}$ .

Fig.9 Waveforms showing the removal times;  $\overline{nR}_D$  to  $nA$  or  $nB$ .



(1) HC :  $V_M = V_M = 50\%$ ;  $V_I = \text{GND to } V_{CC}$ .  
HCT :  $V_M = V_M = 1.3 \text{ V}$ ;  $V_I = \text{GND to } 3 \text{ V}$ .

Fig.10 Waveforms showing the triggering of One Shot by input  $nA$  or input  $nB$  for one period ( $t_W$ ) and minimum pulse widths of the trigger inputs  $nA$  and  $nB$ .

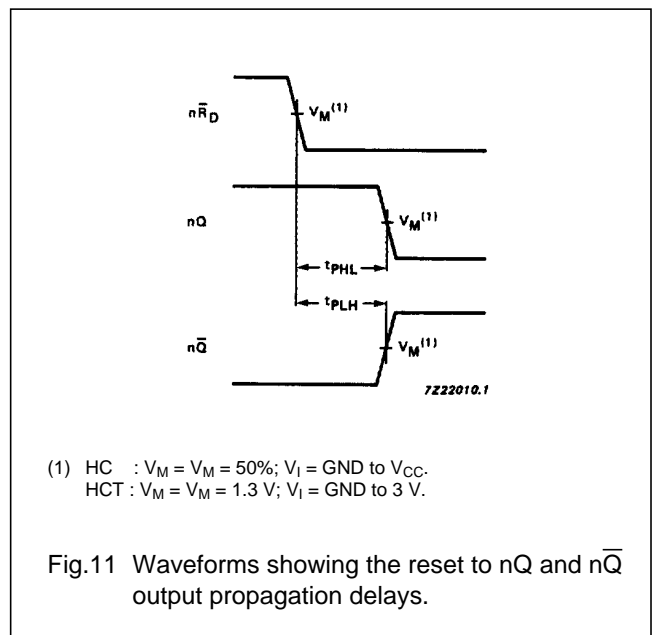

(1) HC :  $V_M = V_M = 50\%$ ;  $V_I = \text{GND to } V_{CC}$ .  
HCT :  $V_M = V_M = 1.3 \text{ V}$ ;  $V_I = \text{GND to } 3 \text{ V}$ .

Fig.11 Waveforms showing the reset to  $nQ$  and  $nQ\text{-bar}$  output propagation delays.

# Dual non-retriggerable monostable multivibrator with reset

74HC/HCT221

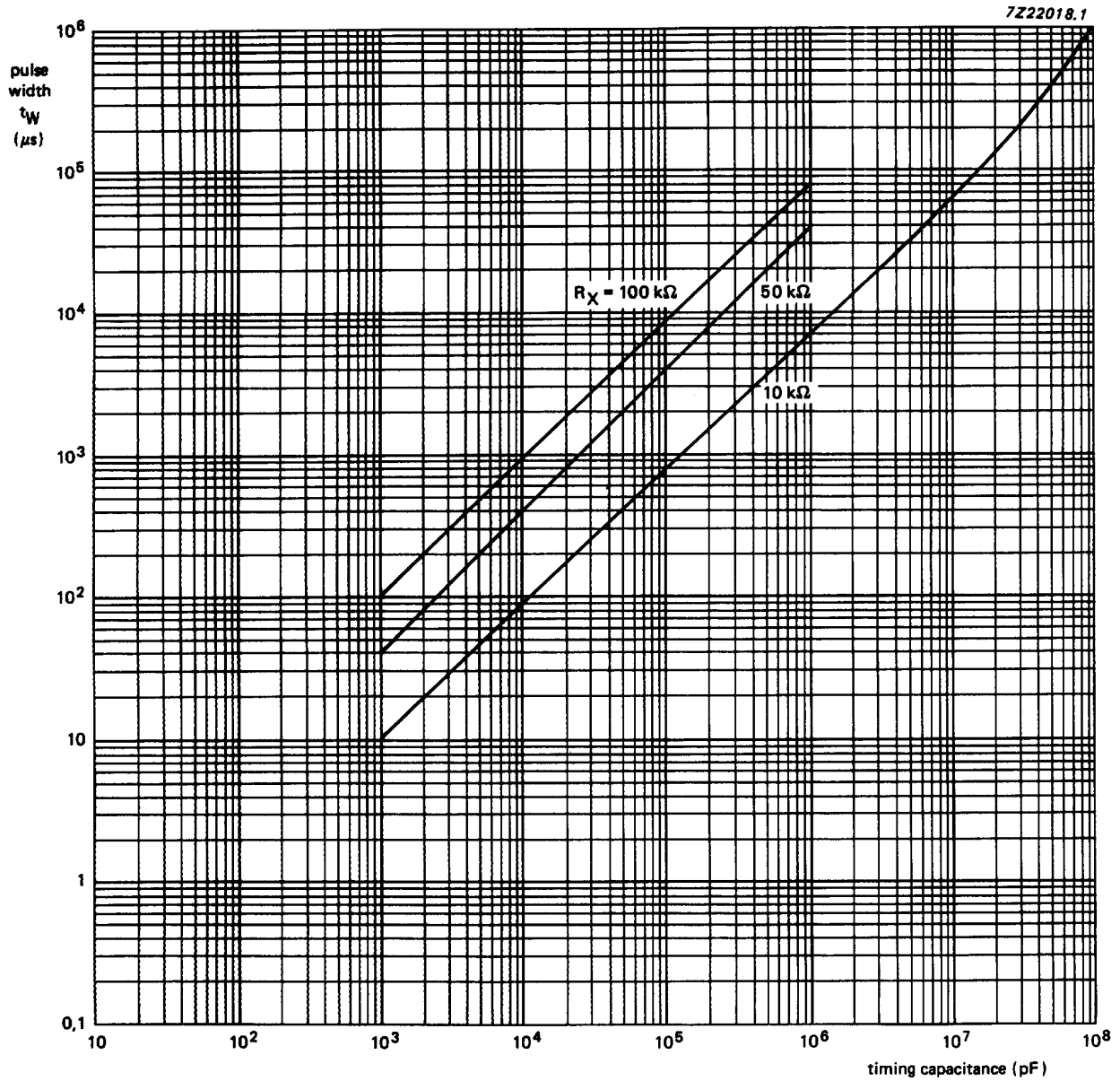

Fig.12 HC typical output pulse width as a function of timing capacitance ( $V_{CC} = 2\text{ V}$ ).

# Dual non-retriggerable monostable multivibrator with reset

## 74HC/HCT221

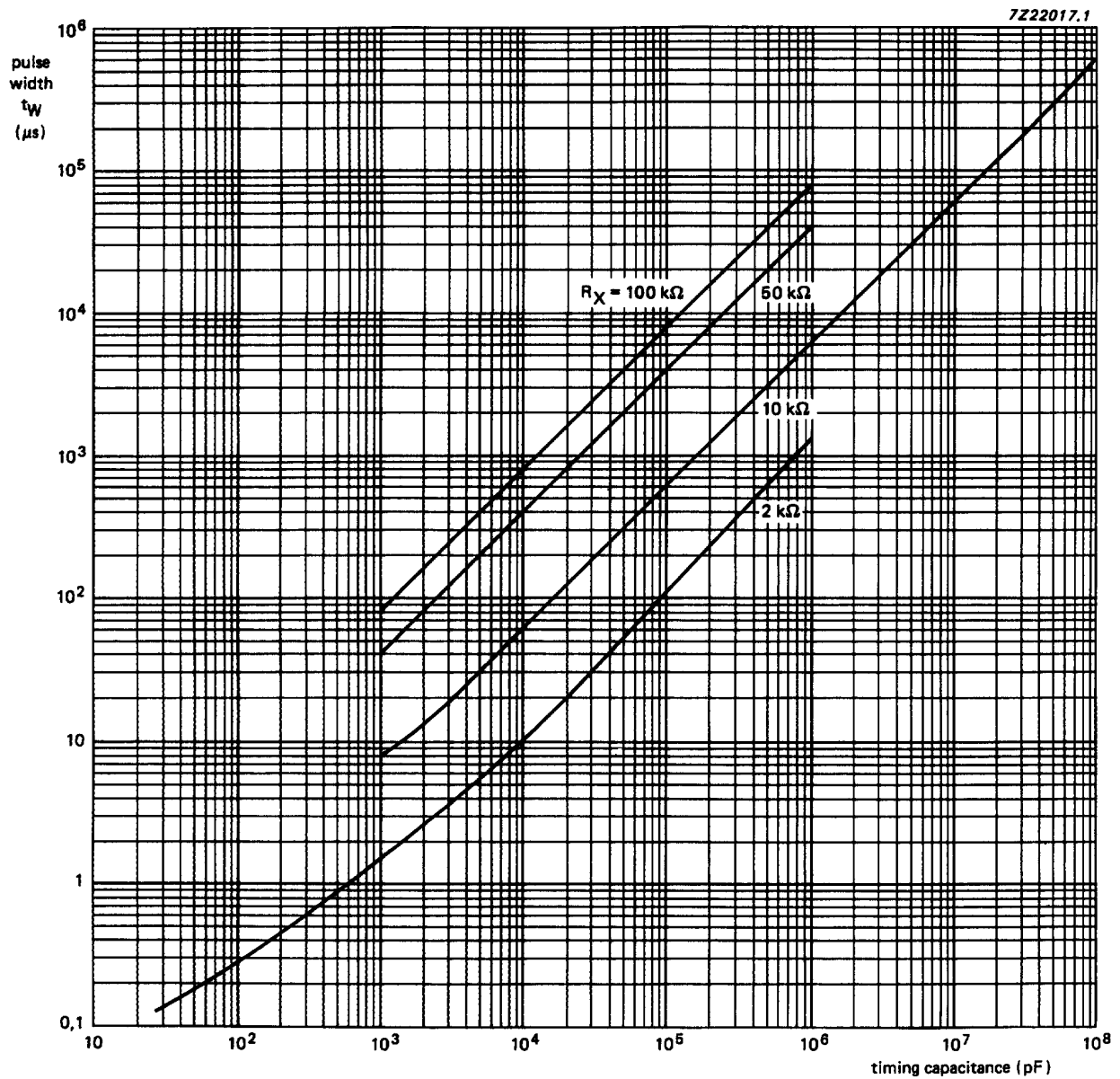

Fig.13 HC/HCT typical output pulse width as a function of timing capacitance ( $V_{CC} = 4.5\text{ V}$ ).

# Dual non-retriggerable monostable multivibrator with reset

74HC/HCT221

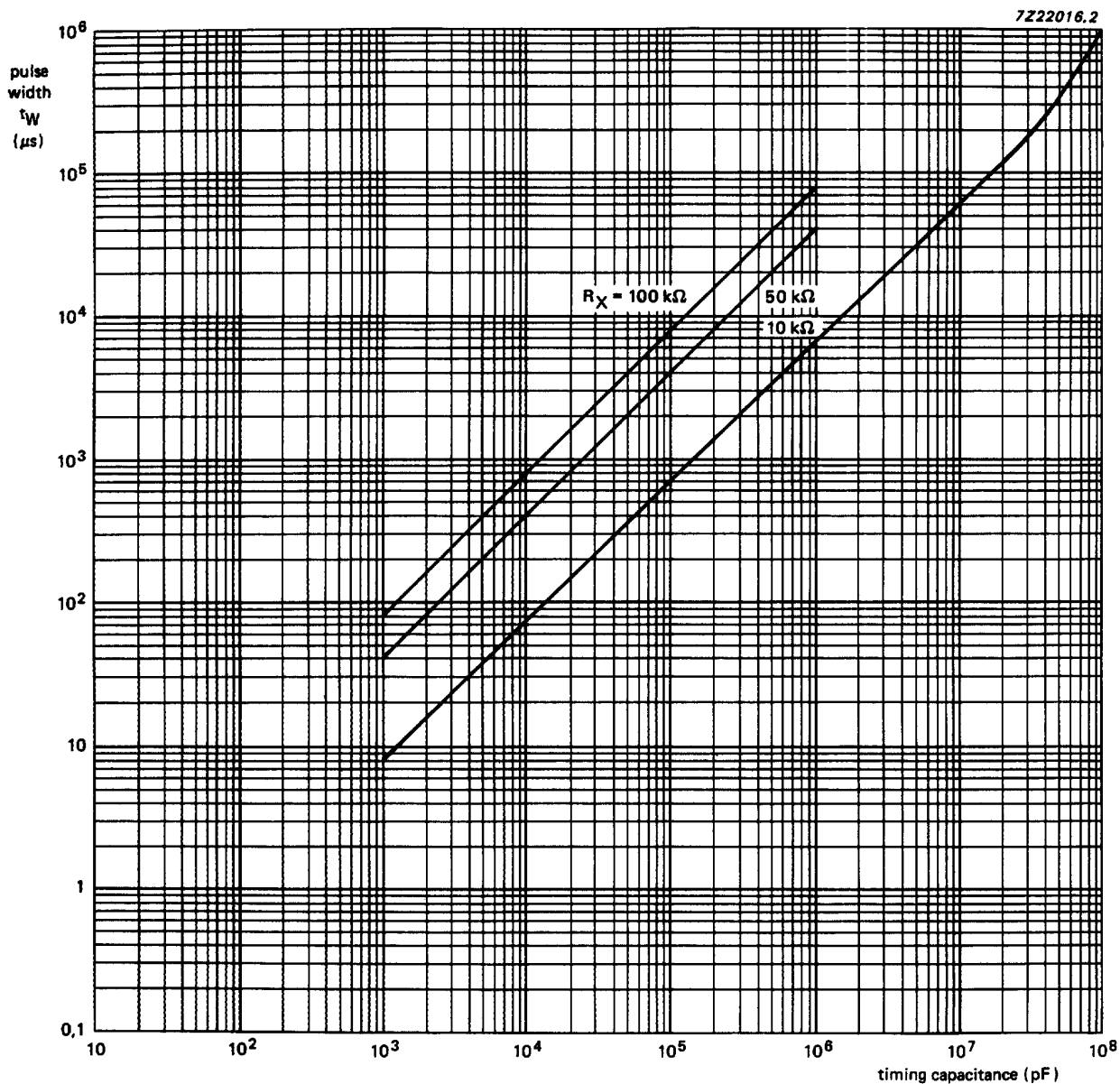

Fig.14 HC typical output pulse width as a function of timing capacitance ( $V_{CC} = 6\text{ V}$ ).

# Dual non-retriggerable monostable multivibrator with reset

74HC/HCT221

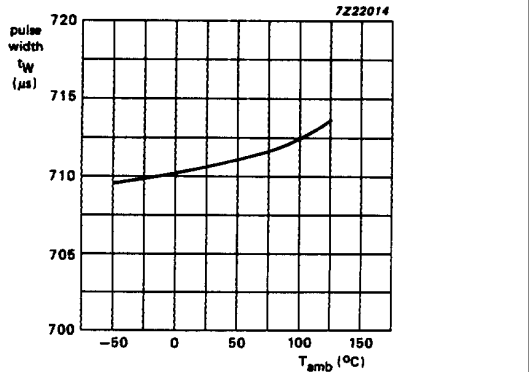

Fig.15 Typical output pulse width as a function of temperature;  $C_X = 0.1 \mu F$ ;  $R_X = 10 K\Omega$ ;  $V_{CC} = 5 V$ .

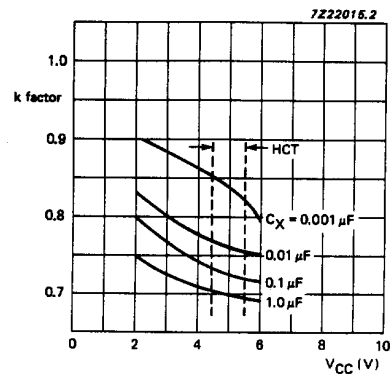

Fig.16 k factor as a function of supply voltage;  $R_X = 10 K\Omega$ ;  $T_{amb} = 25 \text{ }^\circ C$ .

### Power-down consideration

A large capacitor ( $C_X$ ) may cause problems when powering-down the monostable due to the energy stored in this capacitor. When a system containing this device is powered-down or a rapid decrease of  $V_{CC}$  to zero occurs, the monostable may sustain damage, due to the capacitor discharging through the input protection diodes. To avoid this possibility, use a damping diode ( $D_X$ ) preferably a germanium or Schottky type diode able to withstand large current surges and connect as shown in Fig.17.

### PACKAGE OUTLINES

See "74HC/HCT/HCU/HCMOS Logic Package Outlines".

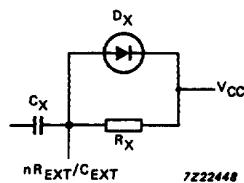

Fig.17 Power-down protection circuit.

## X-ON Electronics

Largest Supplier of Electrical and Electronic Components

*Click to view similar products for [Buffers & Line Drivers](#) category:*

*Click to view products by [NXP](#) manufacturer:*

Other Similar products are found below :

[5962-9217601MSA](#) [634810D](#) [875140G](#) [HEF4022BP](#) [HEF4043BP](#) [NL17SG125DFT2G](#) [NL17SZ126P5T5G](#) [NLU1GT126CMUTCG](#)  
[NLU3G16AMX1TCG](#) [NLV27WZ125USG](#) [MC74HCT365ADTR2G](#) [BCM6306KMLG](#) [54FCT240CTDB](#) [Le87401NQC](#) [Le87402MQC](#)  
[028192B](#) [042140C](#) [051117G](#) [070519XB](#) [065312DB](#) [091056E](#) [098456D](#) [NL17SG07DFT2G](#) [NL17SG17DFT2G](#) [NL17SG34DFT2G](#)  
[NL17SZ07P5T5G](#) [NL17SZ125P5T5G](#) [NLU1GT126AMUTCG](#) [NLV27WZ16DFT2G](#) [5962-8982101PA](#) [5962-9052201PA](#) [74LVC07ADR2G](#)  
[MC74VHC1G125DFT1G](#) [NL17SH17P5T5G](#) [NL17SZ125CMUTCG](#) [NLV17SZ07DFT2G](#) [NLV37WZ17USG](#) [NLVHCT244ADTR2G](#)  
[NC7WZ17FHX](#) [74HCT126T14-13](#) [NL17SH125P5T5G](#) [NLV14049UBDTR2G](#) [NLV37WZ07USG](#) [74VHC541FT\(BE\)](#) [RHFAC244K1](#)  
[74LVC1G17FW4-7](#) [74LVC1G126FZ4-7](#) [BCM6302KMLG](#) [74LVC1G07FZ4-7](#) [74LVC1G125FW4-7](#)