

# DATA SHEET

## **FAMILY SPECIFICATIONS** HCMOS family characteristics

March 1988

File under Integrated Circuits, IC06

# DATA SHEET

Package outline drawings

January 1996

File under Integrated Circuits, IC06

## Package outline drawings

### INDEX

PACKAGE VERSIONS	DESCRIPTION	PAGE
<b>DIP</b>		
SOT27-1	plastic dual in-line package; 14 leads (300 mil)	3
SOT38-4	plastic dual in-line package; 16 leads (300 mil)	4
SOT146-1	plastic dual in-line package; 20 leads (300 mil)	5
SOT101-1	plastic dual in-line package; 24 leads (600 mil)	6
SOT222-1	plastic dual in-line package; 24 leads (300 mil)	7
SOT117-1	plastic dual in-line package; 28 leads (600 mil)	8
<b>SO</b>		
SOT96-1	plastic small outline package; 8 leads; body width 3.9 mm	9
SOT108-1	plastic small outline package; 14 leads; body width 3.9 mm	10
SOT109-1	plastic small outline package; 16 leads; body width 3.9 mm	11
SOT162-1	plastic small outline package; 16 leads; body width 7.5 mm	12
SOT163-1	plastic small outline package; 20 leads; body width 7.5 mm	13
SOT137-1	plastic small outline package; 24 leads; body width 7.5 mm	14
SOT136-1	plastic small outline package; 28 leads; body width 7.5 mm	15
<b>SSOP</b>		
SOT337-1	plastic shrink small outline package; 14 leads; body width 5.3 mm	16
SOT338-1	plastic shrink small outline package; 16 leads; body width 5.3 mm	17
SOT339-1	plastic shrink small outline package; 20 leads; body width 5.3 mm	18
SOT340-1	plastic shrink small outline package; 24 leads; body width 5.3 mm	19
<b>TSSOP</b>		
SOT402-1	plastic thin shrink small outline package; 14 leads; body width 4.4 mm	20
SOT403-1	plastic thin shrink small outline package; 16 leads; body width 4.4 mm	21
SOT360-1	plastic thin shrink small outline package; 20 leads; body width 4.4 mm	22
SOT355-1	plastic thin shrink small outline package; 24 leads; body width 4.4 mm	23

# Package outline drawings

## DIP

DIP14: plastic dual in-line package; 14 leads (300 mil)

SOT27-1

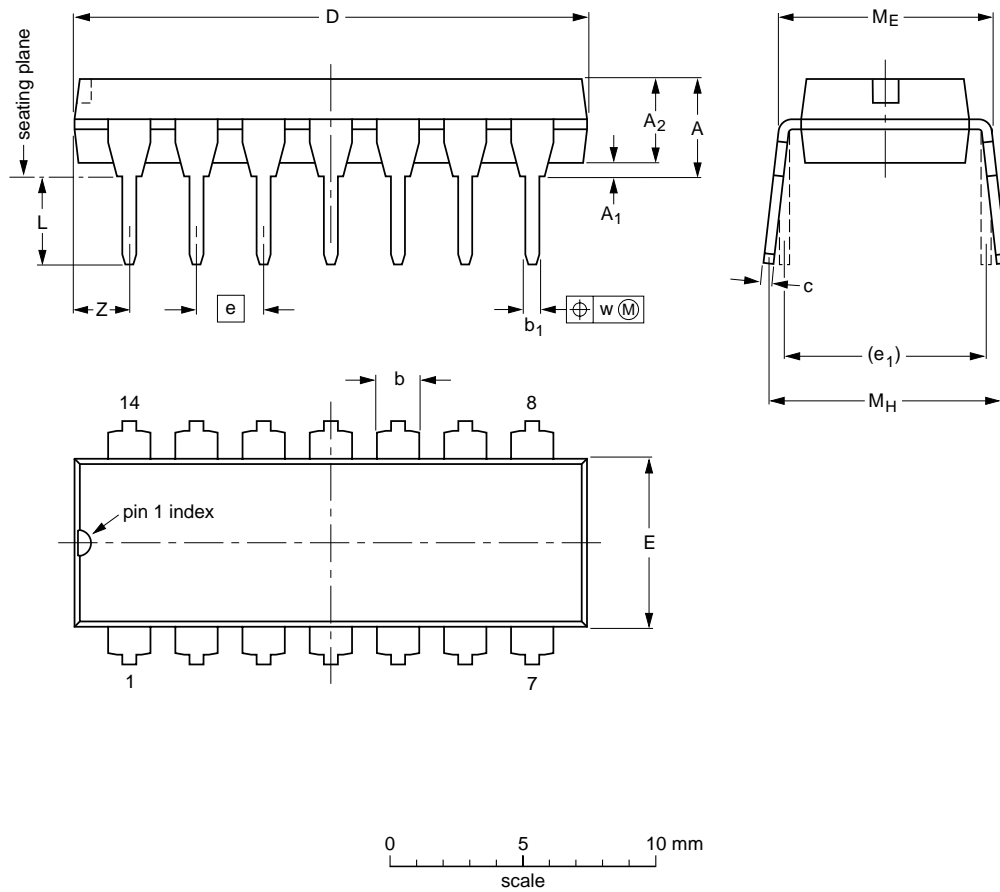

**DIMENSIONS** (inch dimensions are derived from the original mm dimensions)

UNIT	A max.	A <sub>1</sub> min.	A <sub>2</sub> max.	b	b <sub>1</sub>	c	D <sup>(1)</sup>	E <sup>(1)</sup>	e	e <sub>1</sub>	L	M <sub>E</sub>	M <sub>H</sub>	w	Z <sup>(1)</sup> max.
mm	4.2	0.51	3.2	1.73 1.13	0.53 0.38	0.36 0.23	19.50 18.55	6.48 6.20	2.54	7.62	3.60 3.05	8.25 7.80	10.0 8.3	0.254	2.2
inches	0.17	0.020	0.13	0.068 0.044	0.021 0.015	0.014 0.009	0.77 0.73	0.26 0.24	0.10	0.30	0.14 0.12	0.32 0.31	0.39 0.33	0.01	0.087

**Note**

1. Plastic or metal protrusions of 0.25 mm maximum per side are not included.

OUTLINE VERSION	REFERENCES				EUROPEAN PROJECTION	ISSUE DATE
	IEC	JEDEC	EIAJ			
SOT27-1	050G04	MO-001AA				92-11-17 95-03-11

# Package outline drawings

DIP16: plastic dual in-line package; 16 leads (300 mil)

SOT38-4

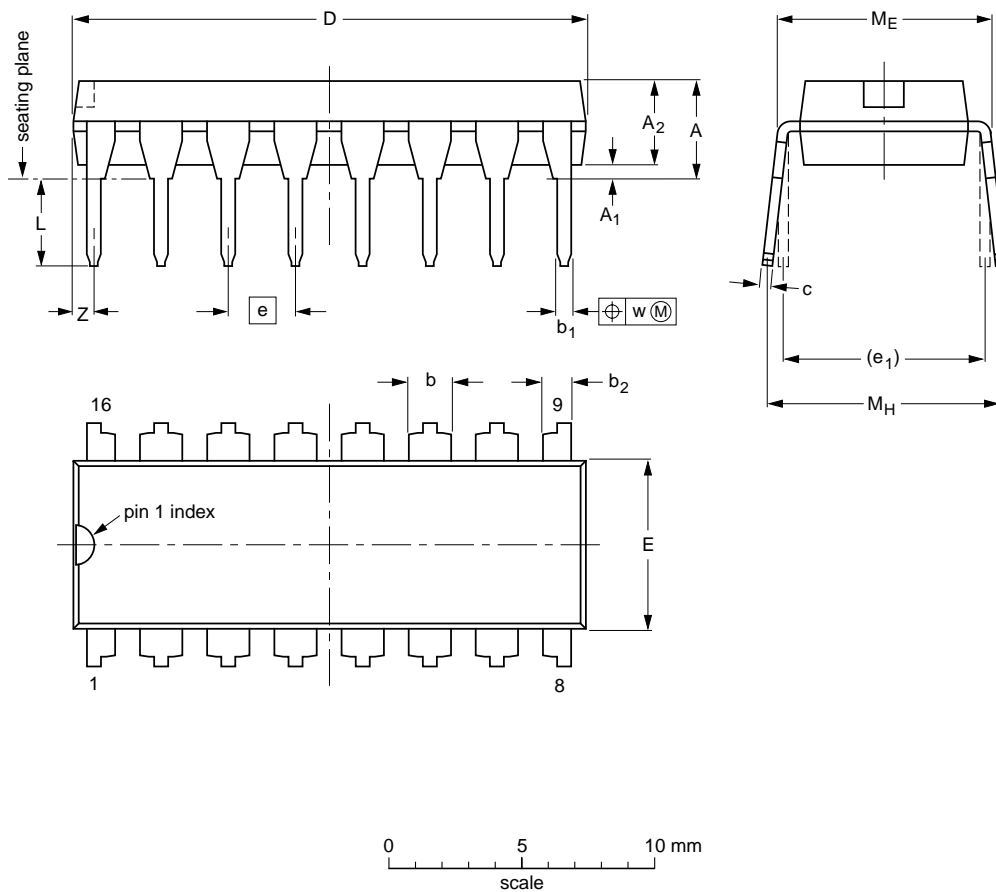

**DIMENSIONS (inch dimensions are derived from the original mm dimensions)**

UNIT	A max.	A <sub>1</sub> min.	A <sub>2</sub> max.	b	b <sub>1</sub>	b <sub>2</sub>	c	D <sup>(1)</sup>	E <sup>(1)</sup>	e	e <sub>1</sub>	L	M <sub>E</sub>	M <sub>H</sub>	w	Z <sup>(1)</sup> max.
mm	4.2	0.51	3.2	1.73 1.30	0.53 0.38	1.25 0.85	0.36 0.23	19.50 18.55	6.48 6.20	2.54	7.62	3.60 3.05	8.25 7.80	10.0 8.3	0.254	0.76
inches	0.17	0.020	0.13	0.068 0.051	0.021 0.015	0.049 0.033	0.014 0.009	0.77 0.73	0.26 0.24	0.10	0.30	0.14 0.12	0.32 0.31	0.39 0.33	0.01	0.030

**Note**

1. Plastic or metal protrusions of 0.25 mm maximum per side are not included.

OUTLINE VERSION	REFERENCES				EUROPEAN PROJECTION	ISSUE DATE
	IEC	JEDEC	EIAJ			
SOT38-4						92-11-17 95-01-14

# Package outline drawings

DIP20: plastic dual in-line package; 20 leads (300 mil)

SOT146-1

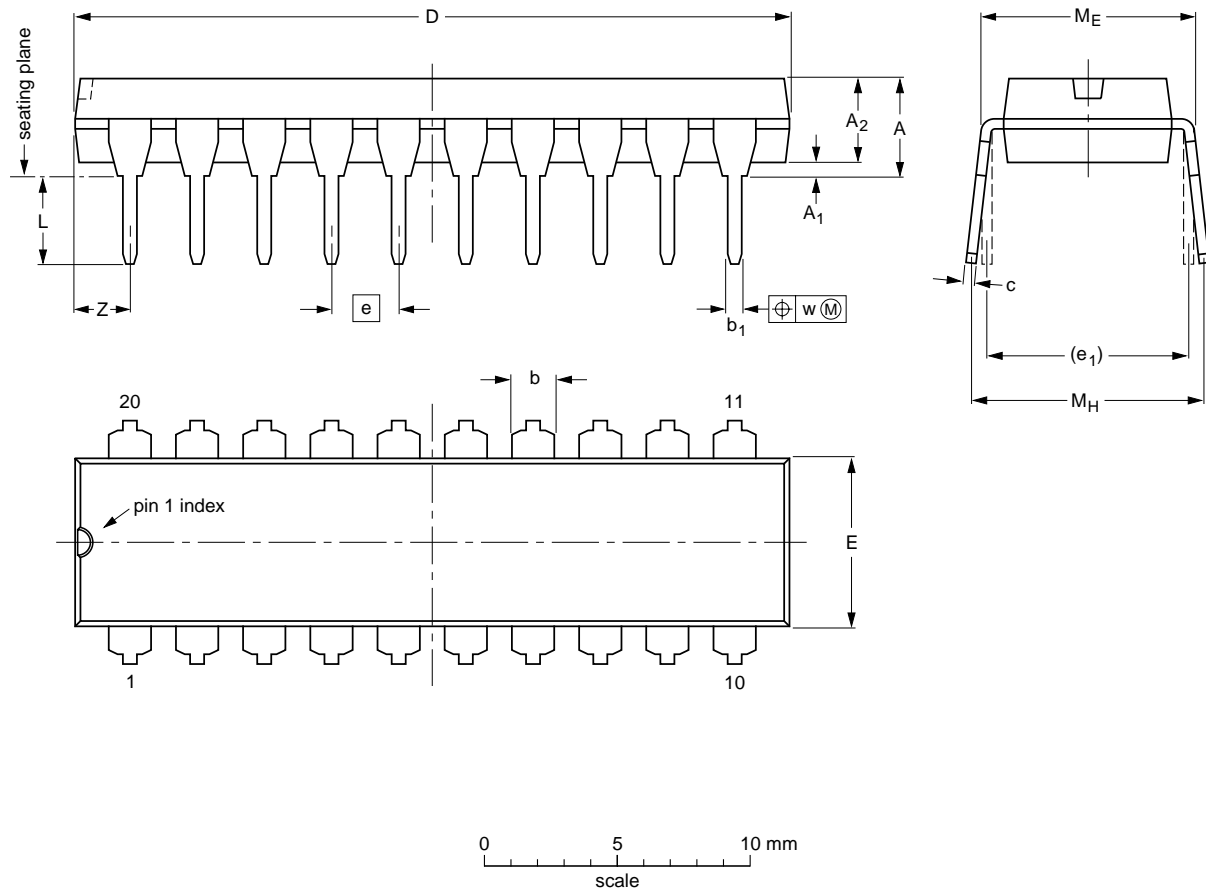

**DIMENSIONS (inch dimensions are derived from the original mm dimensions)**

UNIT	A max.	A <sub>1</sub> min.	A <sub>2</sub> max.	b	b <sub>1</sub>	c	D <sup>(1)</sup>	E <sup>(1)</sup>	e	e <sub>1</sub>	L	M <sub>E</sub>	M <sub>H</sub>	w	Z <sup>(1)</sup> max.
mm	4.2	0.51	3.2	1.73 1.30	0.53 0.38	0.36 0.23	26.92 26.54	6.40 6.22	2.54	7.62	3.60 3.05	8.25 7.80	10.0 8.3	0.254	2.0
inches	0.17	0.020	0.13	0.068 0.051	0.021 0.015	0.014 0.009	1.060 1.045	0.25 0.24	0.10	0.30	0.14 0.12	0.32 0.31	0.39 0.33	0.01	0.078

**Note**

1. Plastic or metal protrusions of 0.25 mm maximum per side are not included.

OUTLINE VERSION	REFERENCES				EUROPEAN PROJECTION	ISSUE DATE
	IEC	JEDEC	EIAJ			
SOT146-1			SC603			92-11-17 95-05-24

# Package outline drawings

DIP24: plastic dual in-line package; 24 leads (600 mil)

SOT101-1

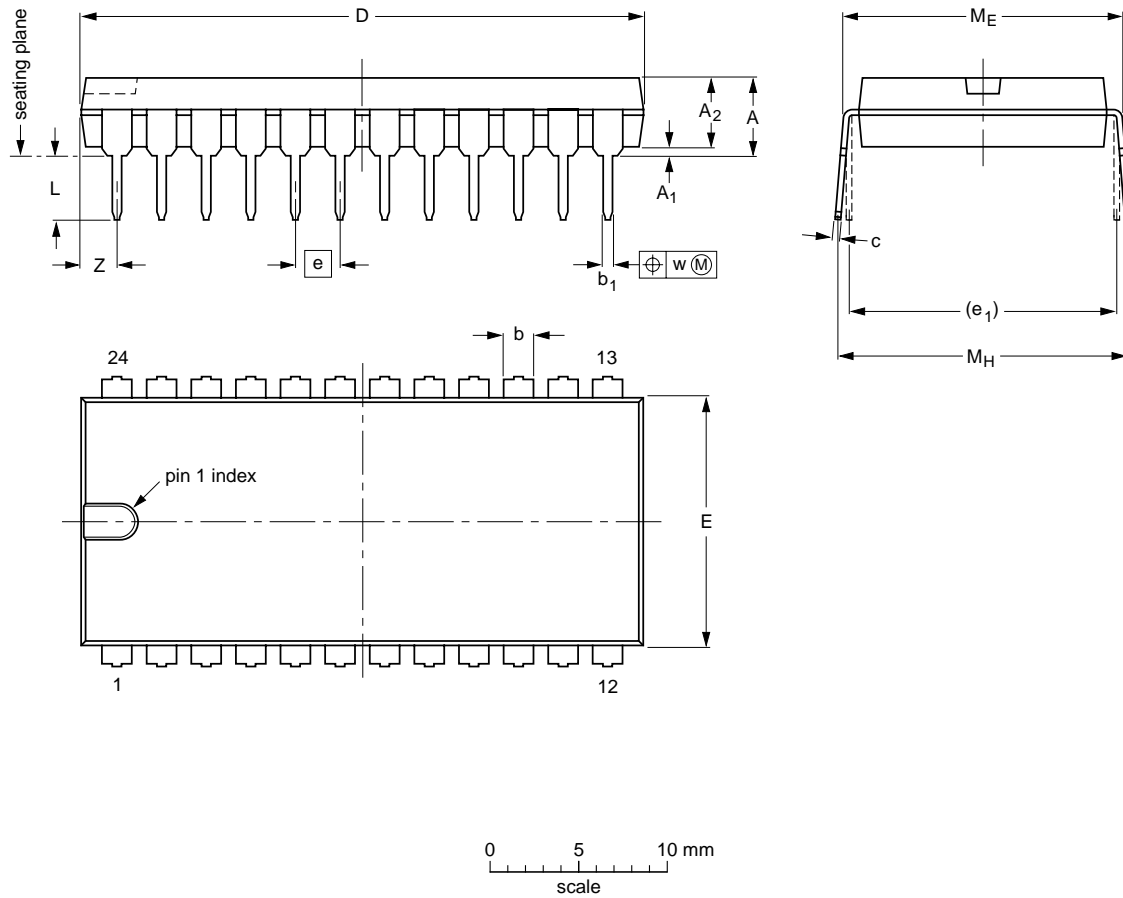

**DIMENSIONS (inch dimensions are derived from the original mm dimensions)**

UNIT	A max.	A <sub>1</sub> min.	A <sub>2</sub> max.	b	b <sub>1</sub>	c	D <sup>(1)</sup>	E <sup>(1)</sup>	e	e <sub>1</sub>	L	M <sub>E</sub>	M <sub>H</sub>	w	Z <sup>(1)</sup> max.
mm	5.1	0.51	4.0	1.7 1.3	0.53 0.38	0.32 0.23	32.0 31.4	14.1 13.7	2.54	15.24	3.9 3.4	15.80 15.24	17.15 15.90	0.25	2.2
inches	0.20	0.020	0.16	0.066 0.051	0.021 0.015	0.013 0.009	1.26 1.24	0.56 0.54	0.10	0.60	0.15 0.13	0.62 0.60	0.68 0.63	0.01	0.087

**Note**

1. Plastic or metal protrusions of 0.25 mm maximum per side are not included.

OUTLINE VERSION	REFERENCES				EUROPEAN PROJECTION	ISSUE DATE
	IEC	JEDEC	EIAJ			
SOT101-1	051G02	MO-015AD				92-11-17 95-01-23

# Package outline drawings

DIP24: plastic dual in-line package; 24 leads (300 mil)

SOT222-1

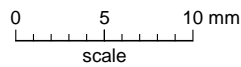
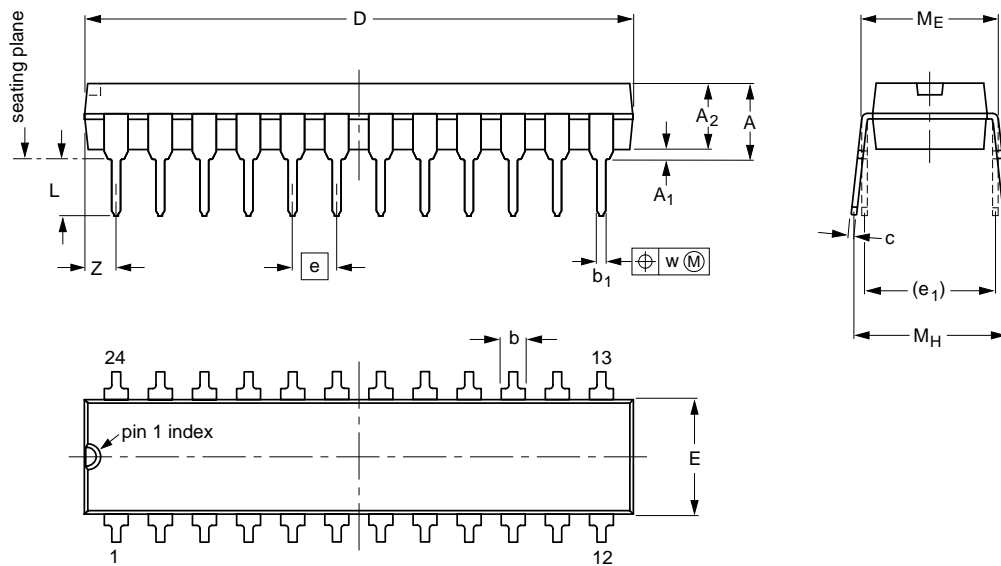

**DIMENSIONS** (millimetre dimensions are derived from the original inch dimensions)

UNIT	A max.	A <sub>1</sub> min.	A <sub>2</sub> max.	b	b <sub>1</sub>	c	D <sup>(1)</sup>	E <sup>(1)</sup>	e	e <sub>1</sub>	L	M <sub>E</sub>	M <sub>H</sub>	w	Z <sup>(1)</sup> max.
mm	4.70	0.38	3.94	1.63 1.14	0.56 0.43	0.36 0.25	31.9 31.5	6.73 6.48	2.54	7.62	3.51 3.05	8.13 7.62	10.03 7.62	0.25	2.05
inches	0.185	0.015	0.155	0.064 0.045	0.022 0.017	0.014 0.010	1.256 1.240	0.265 0.255	0.100	0.300	0.138 0.120	0.32 0.30	0.395 0.300	0.01	0.081

**Note**

1. Plastic or metal protrusions of 0.01 inches maximum per side are not included.

OUTLINE VERSION	REFERENCES				EUROPEAN PROJECTION	ISSUE DATE
	IEC	JEDEC	EIAJ			
SOT222-1		MS-001AF				95-03-11



# Package outline drawings

DIP28: plastic dual in-line package; 28 leads (600 mil)

SOT117-1

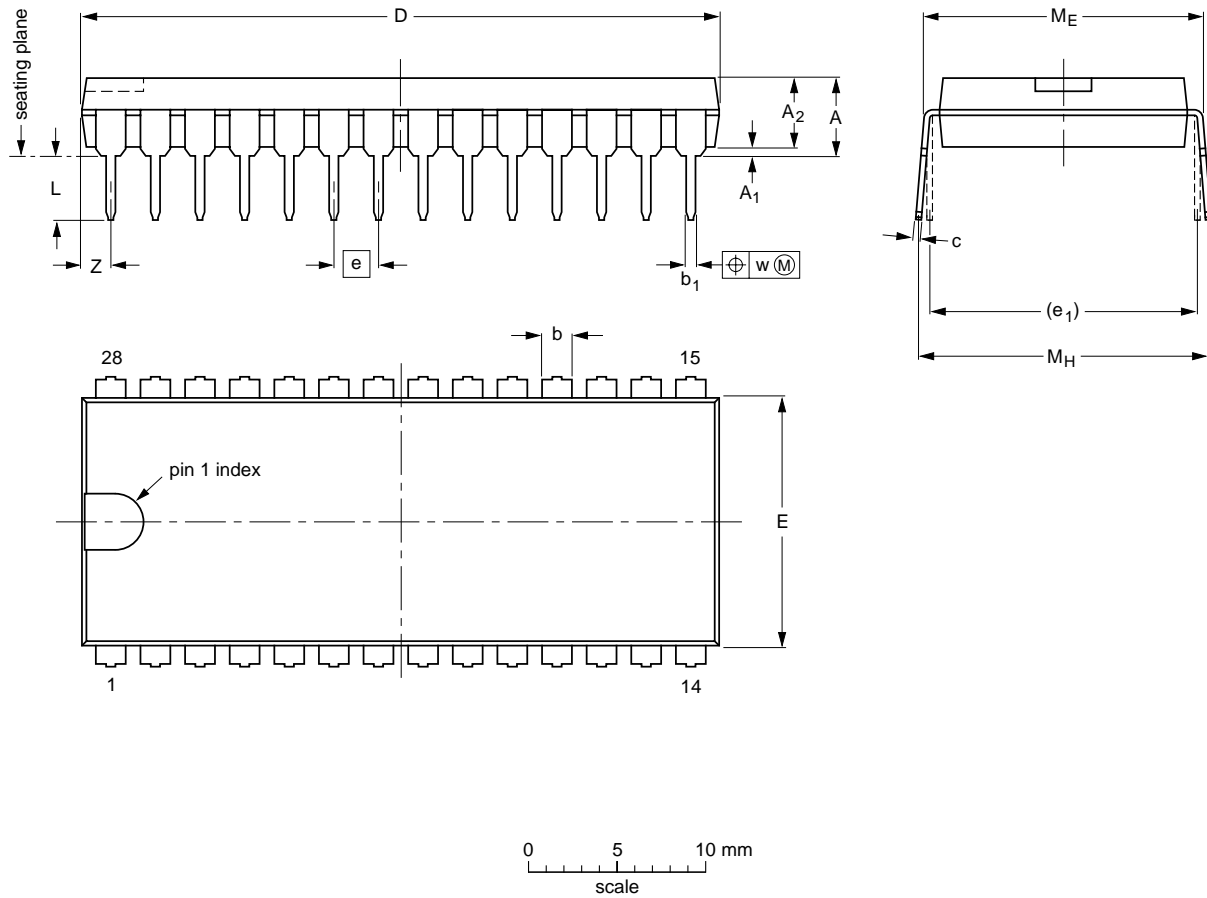

**DIMENSIONS (inch dimensions are derived from the original mm dimensions)**

UNIT	A max.	A <sub>1</sub> min.	A <sub>2</sub> max.	b	b <sub>1</sub>	c	D <sup>(1)</sup>	E <sup>(1)</sup>	e	e <sub>1</sub>	L	M <sub>E</sub>	M <sub>H</sub>	w	Z <sup>(1)</sup> max.
mm	5.1	0.51	4.0	1.7 1.3	0.53 0.38	0.32 0.23	36.0 35.0	14.1 13.7	2.54	15.24	3.9 3.4	15.80 15.24	17.15 15.90	0.25	1.7
inches	0.20	0.020	0.16	0.066 0.051	0.020 0.014	0.013 0.009	1.41 1.34	0.56 0.54	0.10	0.60	0.15 0.13	0.62 0.60	0.68 0.63	0.01	0.067

**Note**

1. Plastic or metal protrusions of 0.25 mm maximum per side are not included.

OUTLINE VERSION	REFERENCES				EUROPEAN PROJECTION	ISSUE DATE
	IEC	JEDEC	EIAJ			
SOT117-1	051G05	MO-015AH				92-11-17 95-01-14

# Package outline drawings

SO

SO8: plastic small outline package; 8 leads; body width 3.9 mm

SOT96-1

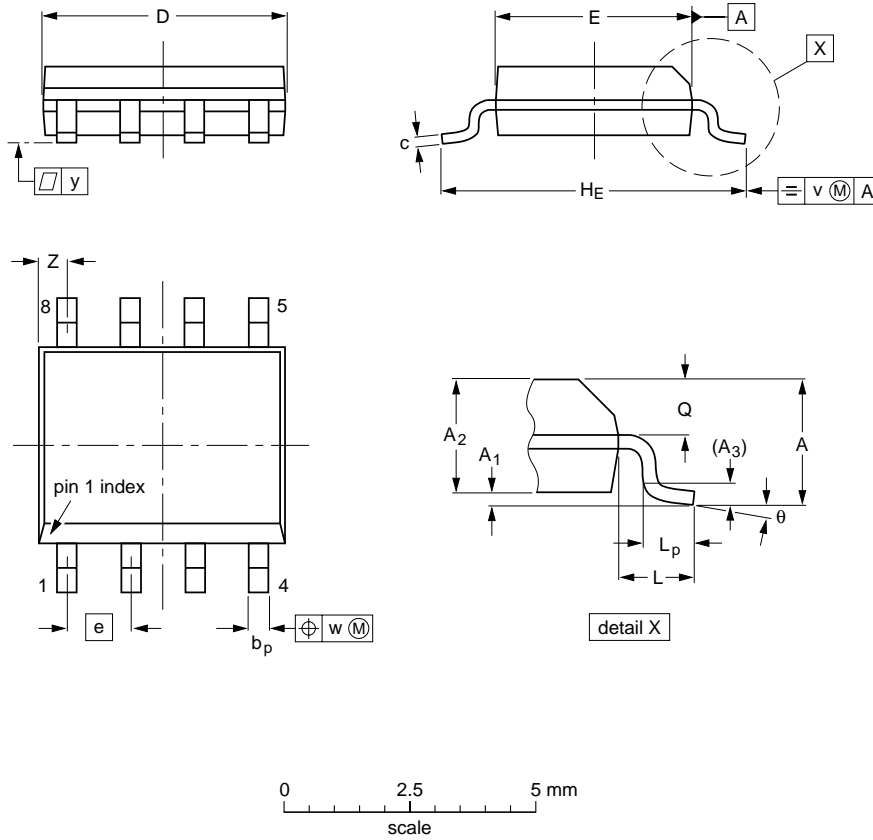

**DIMENSIONS (inch dimensions are derived from the original mm dimensions)**

UNIT	A max.	A <sub>1</sub>	A <sub>2</sub>	A <sub>3</sub>	b <sub>p</sub>	c	D <sup>(1)</sup>	E <sup>(2)</sup>	e	H <sub>E</sub>	L	L <sub>p</sub>	Q	v	w	y	Z <sup>(1)</sup>	θ
mm	1.75	0.25 0.10	1.45 1.25	0.25	0.49 0.36	0.25 0.19	5.0 4.8	4.0 3.8	1.27	6.2 5.8	1.05	1.0 0.4	0.7 0.6	0.25	0.25	0.1	0.7 0.3	8° 0°
inches	0.069	0.010 0.004	0.057 0.049	0.01	0.019 0.014	0.0100 0.0075	0.20 0.19	0.16 0.15	0.050	0.244 0.228	0.041	0.039 0.016	0.028 0.024	0.01	0.01	0.004	0.028 0.012	

**Notes**

1. Plastic or metal protrusions of 0.15 mm maximum per side are not included.
2. Plastic or metal protrusions of 0.25 mm maximum per side are not included.

OUTLINE VERSION	REFERENCES				EUROPEAN PROJECTION	ISSUE DATE
	IEC	JEDEC	EIAJ			
SOT96-1	076E03S	MS-012AA				95-02-04 97-05-22

# Package outline drawings

**SO14: plastic small outline package; 14 leads; body width 3.9 mm**

**SOT108-1**

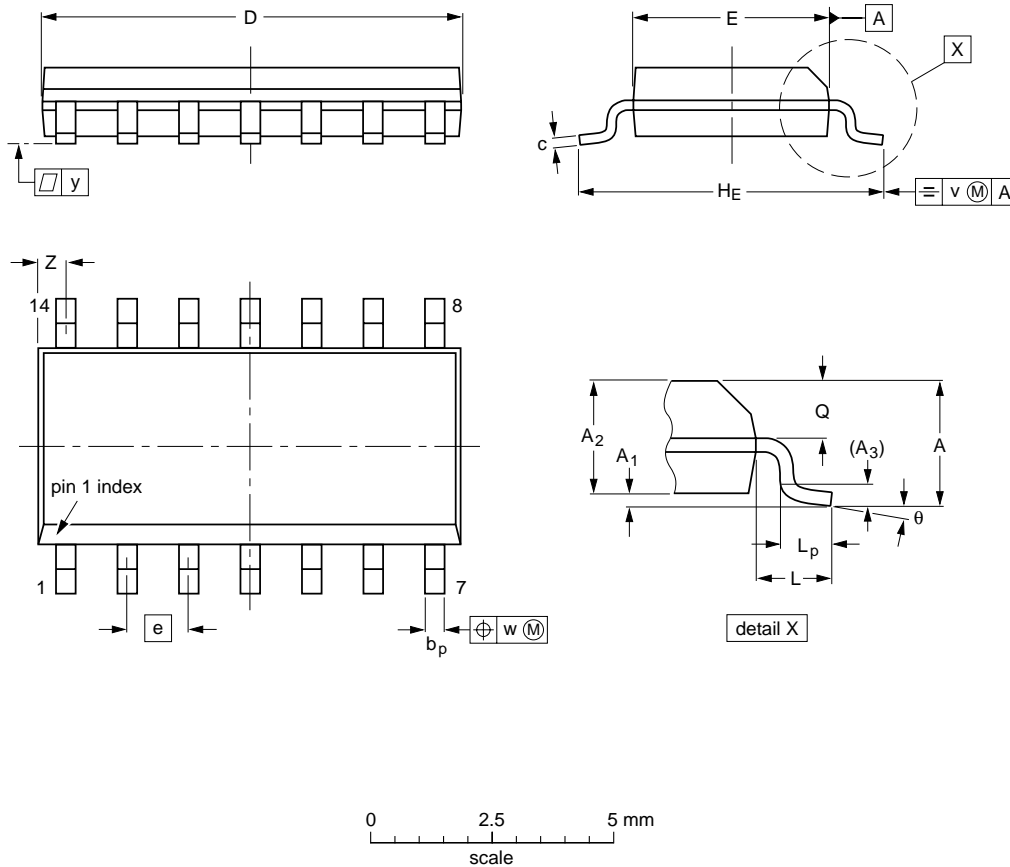

**DIMENSIONS** (inch dimensions are derived from the original mm dimensions)

UNIT	A max.	A <sub>1</sub>	A <sub>2</sub>	A <sub>3</sub>	b <sub>p</sub>	c	D <sup>(1)</sup>	E <sup>(1)</sup>	e	H <sub>E</sub>	L	L <sub>p</sub>	Q	v	w	y	Z <sup>(1)</sup>	θ
mm	1.75	0.25 0.10	1.45 1.25	0.25	0.49 0.36	0.25 0.19	8.75 8.55	4.0 3.8	1.27	6.2 5.8	1.05	1.0 0.4	0.7 0.6	0.25	0.25	0.1	0.7 0.3	8° 0°
inches	0.069	0.010 0.004	0.057 0.049	0.01	0.019 0.014	0.0100 0.0075	0.35 0.34	0.16 0.15	0.050	0.244 0.228	0.041	0.039 0.016	0.028 0.024	0.01	0.01	0.004	0.028 0.012	

**Note**

1. Plastic or metal protrusions of 0.15 mm maximum per side are not included.

OUTLINE VERSION	REFERENCES				EUROPEAN PROJECTION	ISSUE DATE
	IEC	JEDEC	EIAJ			
SOT108-1	076E06S	MS-012AB				95-01-23 97-05-22

# Package outline drawings

**SO16: plastic small outline package; 16 leads; body width 3.9 mm**

**SOT109-1**

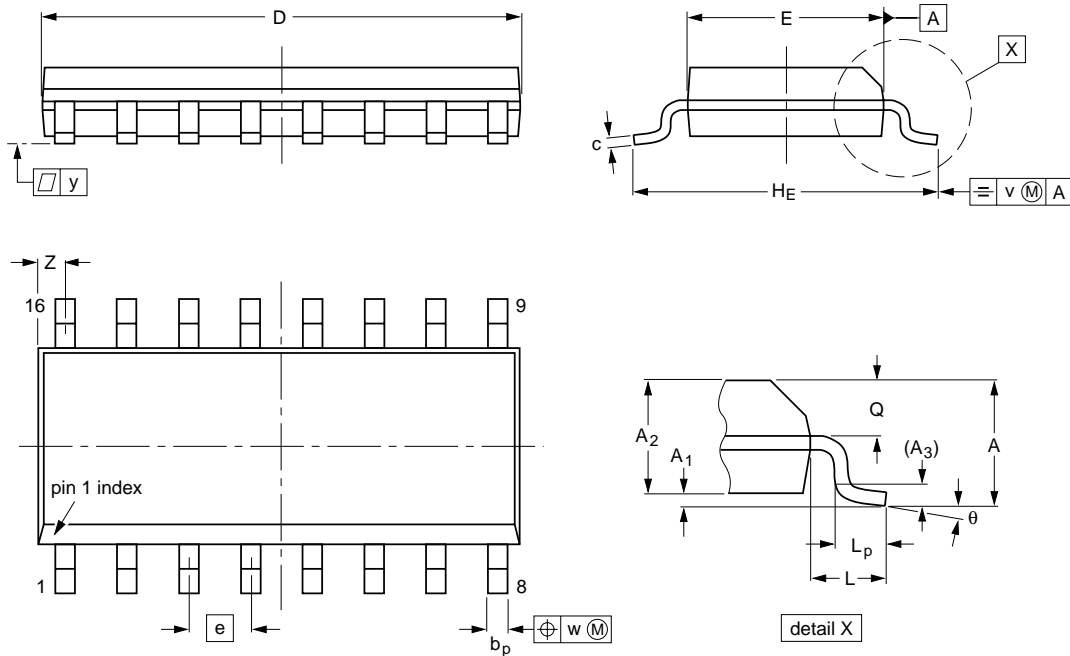

**DIMENSIONS (inch dimensions are derived from the original mm dimensions)**

UNIT	A max.	A <sub>1</sub>	A <sub>2</sub>	A <sub>3</sub>	b <sub>p</sub>	c	D <sup>(1)</sup>	E <sup>(1)</sup>	e	H <sub>E</sub>	L	L <sub>p</sub>	Q	v	w	y	Z <sup>(1)</sup>	θ
mm	1.75	0.25 0.10	1.45 1.25	0.25	0.49 0.36	0.25 0.19	10.0 9.8	4.0 3.8	1.27	6.2 5.8	1.05	1.0 0.4	0.7 0.6	0.25	0.25	0.1	0.7 0.3	8° 0°
inches	0.069	0.010 0.004	0.057 0.049	0.01	0.019 0.014	0.0100 0.0075	0.39 0.38	0.16 0.15	0.050	0.244 0.228	0.041	0.039 0.016	0.028 0.020	0.01	0.01	0.004	0.028 0.012	

**Note**

1. Plastic or metal protrusions of 0.15 mm maximum per side are not included.

OUTLINE VERSION	REFERENCES				EUROPEAN PROJECTION	ISSUE DATE
	IEC	JEDEC	EIAJ			
SOT109-1	076E07S	MS-012AC				95-01-23 97-05-22

# Package outline drawings

**SOT162-1: plastic small outline package; 16 leads; body width 7.5 mm**

**SOT162-1**

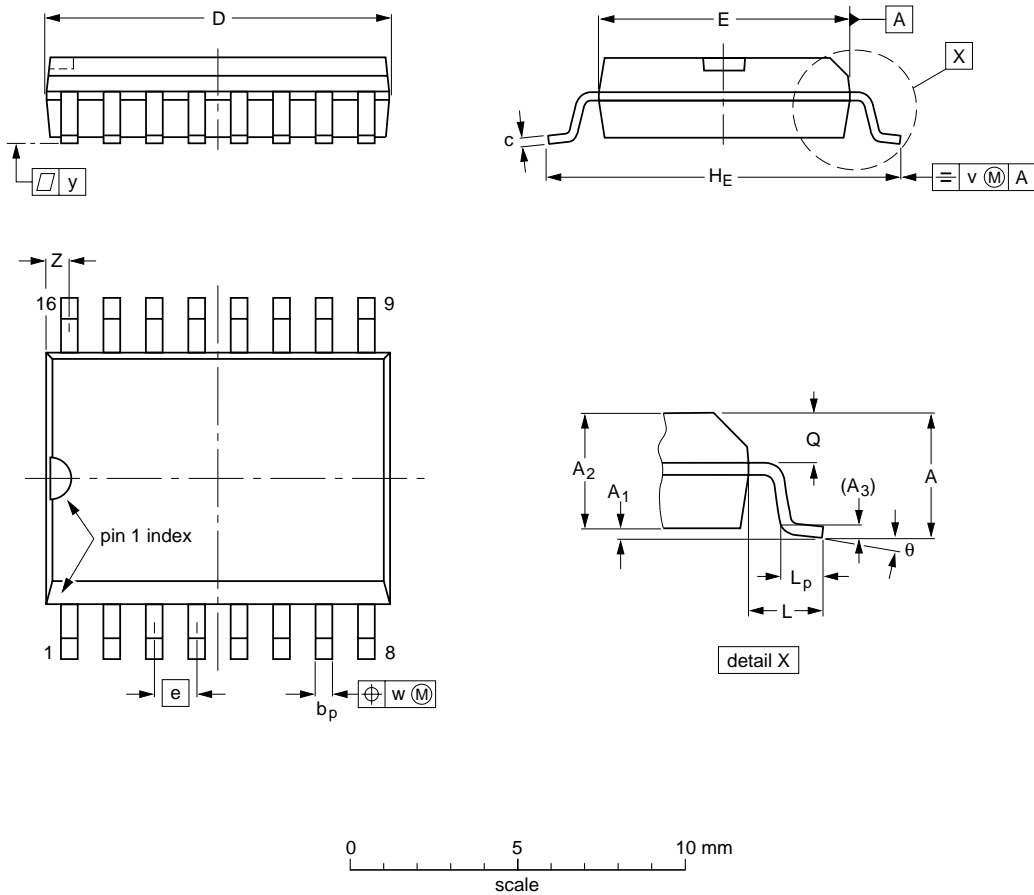

**DIMENSIONS (inch dimensions are derived from the original mm dimensions)**

UNIT	A max.	A <sub>1</sub>	A <sub>2</sub>	A <sub>3</sub>	b <sub>p</sub>	c	D <sup>(1)</sup>	E <sup>(1)</sup>	e	H <sub>E</sub>	L	L <sub>p</sub>	Q	v	w	y	Z <sup>(1)</sup>	θ
mm	2.65	0.30 0.10	2.45 2.25	0.25	0.49 0.36	0.32 0.23	10.5 10.1	7.6 7.4	1.27	10.65 10.00	1.4	1.1 0.4	1.1 1.0	0.25	0.25	0.1	0.9 0.4	8° 0°
inches	0.10	0.012 0.004	0.096 0.089	0.01	0.019 0.014	0.013 0.009	0.41 0.40	0.30 0.29	0.050	0.419 0.394	0.055	0.043 0.016	0.043 0.039	0.01	0.01	0.004	0.035 0.016	

**Note**

1. Plastic or metal protrusions of 0.15 mm maximum per side are not included.

OUTLINE VERSION	REFERENCES				EUROPEAN PROJECTION	ISSUE DATE
	IEC	JEDEC	EIAJ			
SOT162-1	075E03	MS-013AA				95-01-24 97-05-22

# Package outline drawings

**SO20: plastic small outline package; 20 leads; body width 7.5 mm**

**SOT163-1**

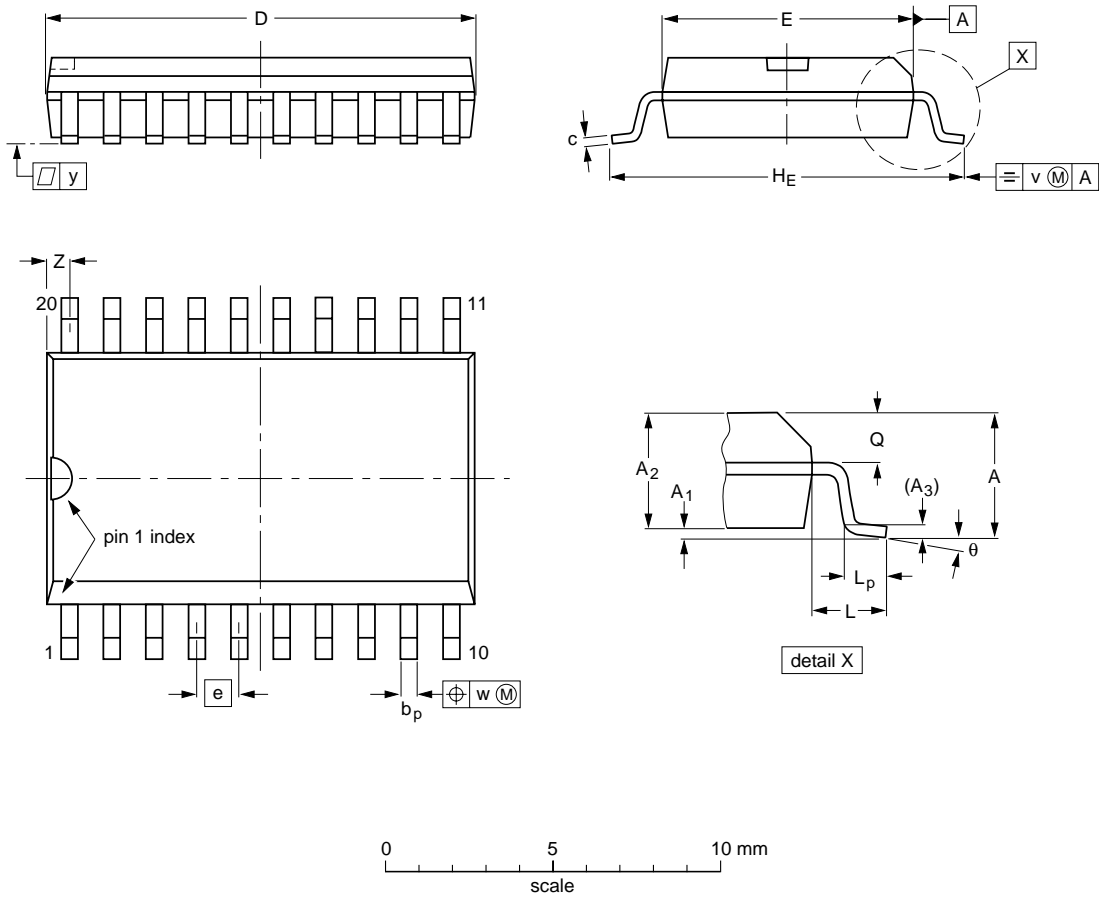

**DIMENSIONS (inch dimensions are derived from the original mm dimensions)**

UNIT	A max.	A <sub>1</sub>	A <sub>2</sub>	A <sub>3</sub>	b <sub>p</sub>	c	D <sup>(1)</sup>	E <sup>(1)</sup>	e	H <sub>E</sub>	L	L <sub>p</sub>	Q	v	w	y	Z <sup>(1)</sup>	θ
mm	2.65	0.30 0.10	2.45 2.25	0.25	0.49 0.36	0.32 0.23	13.0 12.6	7.6 7.4	1.27	10.65 10.00	1.4	1.1 0.4	1.1 1.0	0.25	0.25	0.1	0.9 0.4	8° 0°
inches	0.10	0.012 0.004	0.096 0.089	0.01	0.019 0.014	0.013 0.009	0.51 0.49	0.30 0.29	0.050	0.419 0.394	0.055	0.043 0.016	0.043 0.039	0.01	0.01	0.004	0.035 0.016	

**Note**

1. Plastic or metal protrusions of 0.15 mm maximum per side are not included.

OUTLINE VERSION	REFERENCES				EUROPEAN PROJECTION	ISSUE DATE
	IEC	JEDEC	EIAJ			
SOT163-1	075E04	MS-013AC				-95-01-24 97-05-22

# Package outline drawings

**SO24: plastic small outline package; 24 leads; body width 7.5 mm**

**SOT137-1**

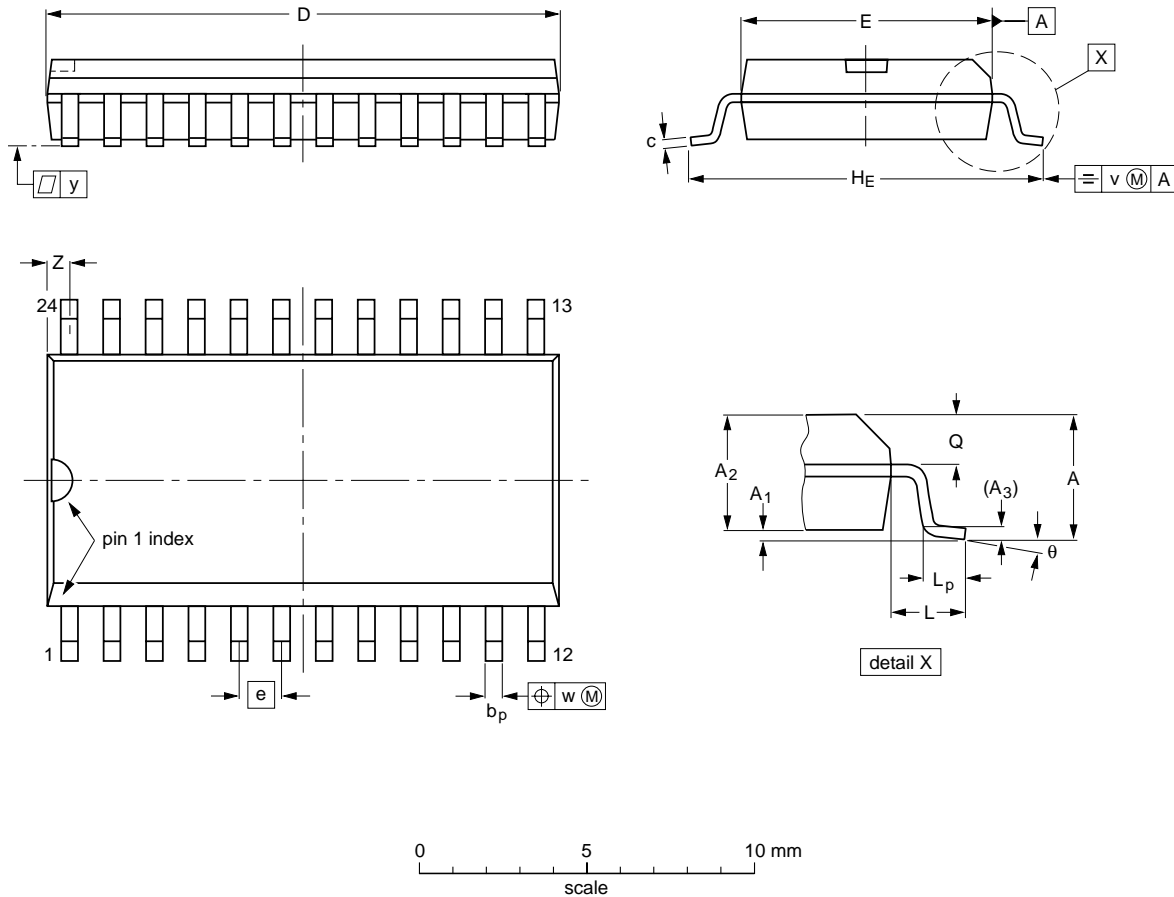

**DIMENSIONS (inch dimensions are derived from the original mm dimensions)**

UNIT	A max.	A <sub>1</sub>	A <sub>2</sub>	A <sub>3</sub>	b <sub>p</sub>	c	D <sup>(1)</sup>	E <sup>(1)</sup>	e	H <sub>E</sub>	L	L <sub>p</sub>	Q	v	w	y	Z <sup>(1)</sup>	$\theta$
mm	2.65	0.30 0.10	2.45 2.25	0.25	0.49 0.36	0.32 0.23	15.6 15.2	7.6 7.4	1.27	10.65 10.00	1.4	1.1 0.4	1.1 1.0	0.25	0.25	0.1	0.9 0.4	8° 0°
inches	0.10	0.012 0.004	0.096 0.089	0.01	0.019 0.014	0.013 0.009	0.61 0.60	0.30 0.29	0.050	0.419 0.394	0.055	0.043 0.016	0.043 0.039	0.01	0.01	0.004	0.035 0.016	

**Note**

1. Plastic or metal protrusions of 0.15 mm maximum per side are not included.

OUTLINE VERSION	REFERENCES				EUROPEAN PROJECTION	ISSUE DATE
	IEC	JEDEC	EIAJ			
SOT137-1	075E05	MS-013AD				95-01-24 97-05-22

# Package outline drawings

SO28: plastic small outline package; 28 leads; body width 7.5 mm

SOT136-1

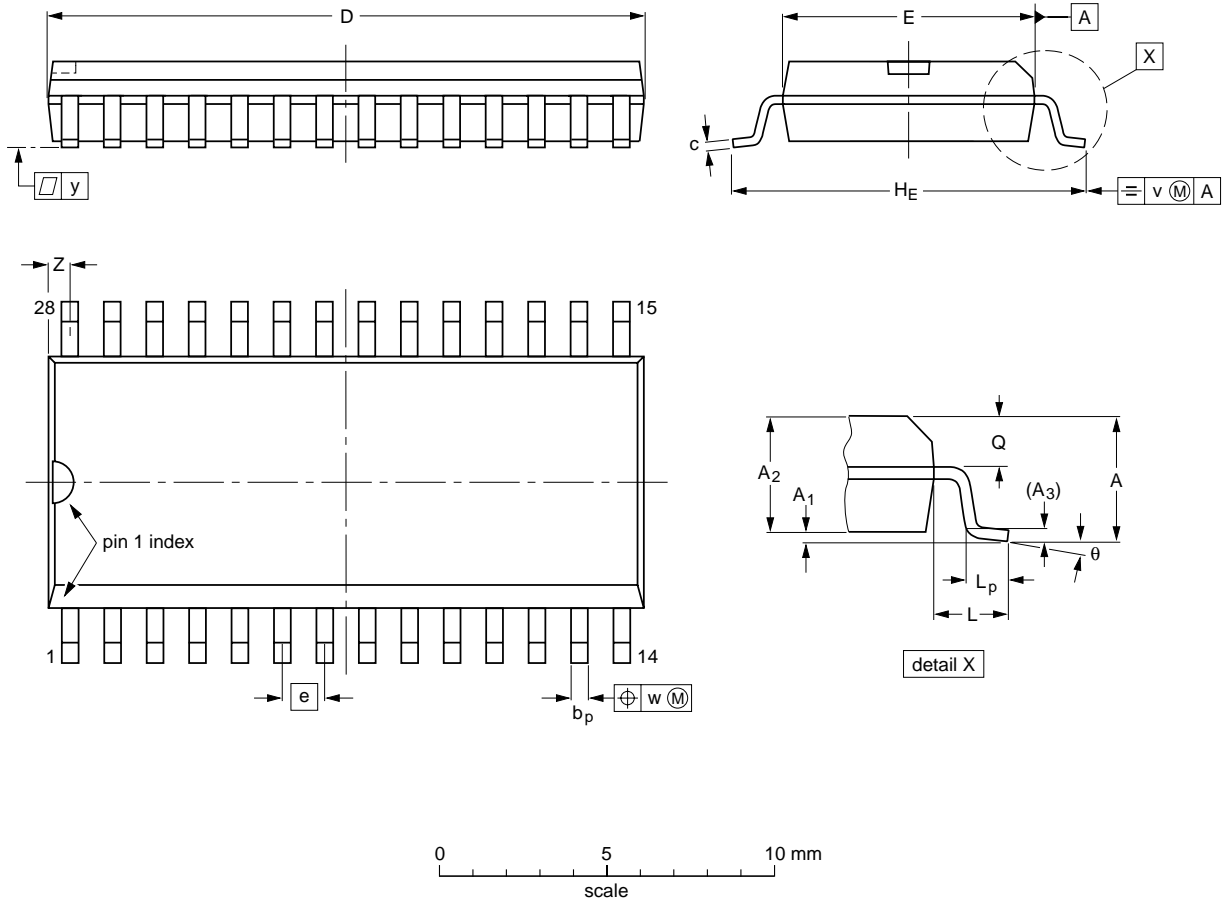

DIMENSIONS (inch dimensions are derived from the original mm dimensions)

UNIT	A max.	A <sub>1</sub>	A <sub>2</sub>	A <sub>3</sub>	b <sub>p</sub>	c	D <sup>(1)</sup>	E <sup>(1)</sup>	e	H <sub>E</sub>	L	L <sub>p</sub>	Q	v	w	y	Z <sup>(1)</sup>	θ
mm	2.65	0.30 0.10	2.45 2.25	0.25	0.49 0.36	0.32 0.23	18.1 17.7	7.6 7.4	1.27	10.65 10.00	1.4	1.1 0.4	1.1 1.0	0.25	0.25	0.1	0.9 0.4	8° 0°
inches	0.10	0.012 0.004	0.096 0.089	0.01	0.019 0.014	0.013 0.009	0.71 0.69	0.30 0.29	0.050	0.419 0.394	0.055	0.043 0.016	0.043 0.039	0.01	0.01	0.004	0.035 0.016	

**Note**

1. Plastic or metal protrusions of 0.15 mm maximum per side are not included.

OUTLINE VERSION	REFERENCES				EUROPEAN PROJECTION	ISSUE DATE
	IEC	JEDEC	EIAJ			
SOT136-1	075E06	MS-013AE				-95-01-24 97-05-22



# Package outline drawings

## SSOP

SSOP14: plastic shrink small outline package; 14 leads; body width 5.3 mm

SOT337-1

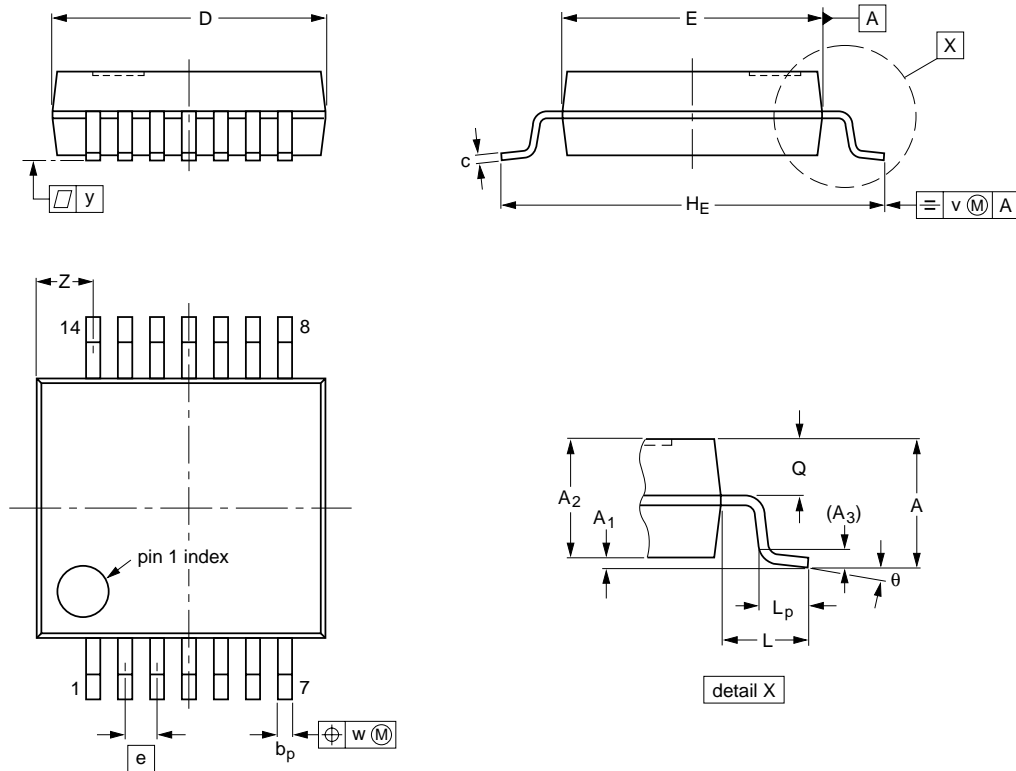

**DIMENSIONS (mm are the original dimensions)**

UNIT	A <sub>max.</sub>	A <sub>1</sub>	A <sub>2</sub>	A <sub>3</sub>	b <sub>p</sub>	c	D <sup>(1)</sup>	E <sup>(1)</sup>	e	H <sub>E</sub>	L	L <sub>p</sub>	Q	v	w	y	Z <sup>(1)</sup>	θ
mm	2.0	0.21 0.05	1.80 1.65	0.25	0.38 0.25	0.20 0.09	6.4 6.0	5.4 5.2	0.65	7.9 7.6	1.25	1.03 0.63	0.9 0.7	0.2	0.13	0.1	1.4 0.9	8° 0°

**Note**

1. Plastic or metal protrusions of 0.25 mm maximum per side are not included.

OUTLINE VERSION	REFERENCES				EUROPEAN PROJECTION	ISSUE DATE
	IEC	JEDEC	EIAJ			
SOT337-1		MO-150AB				95-02-04 96-01-18

# Package outline drawings

SSOP16: plastic shrink small outline package; 16 leads; body width 5.3 mm

SOT338-1

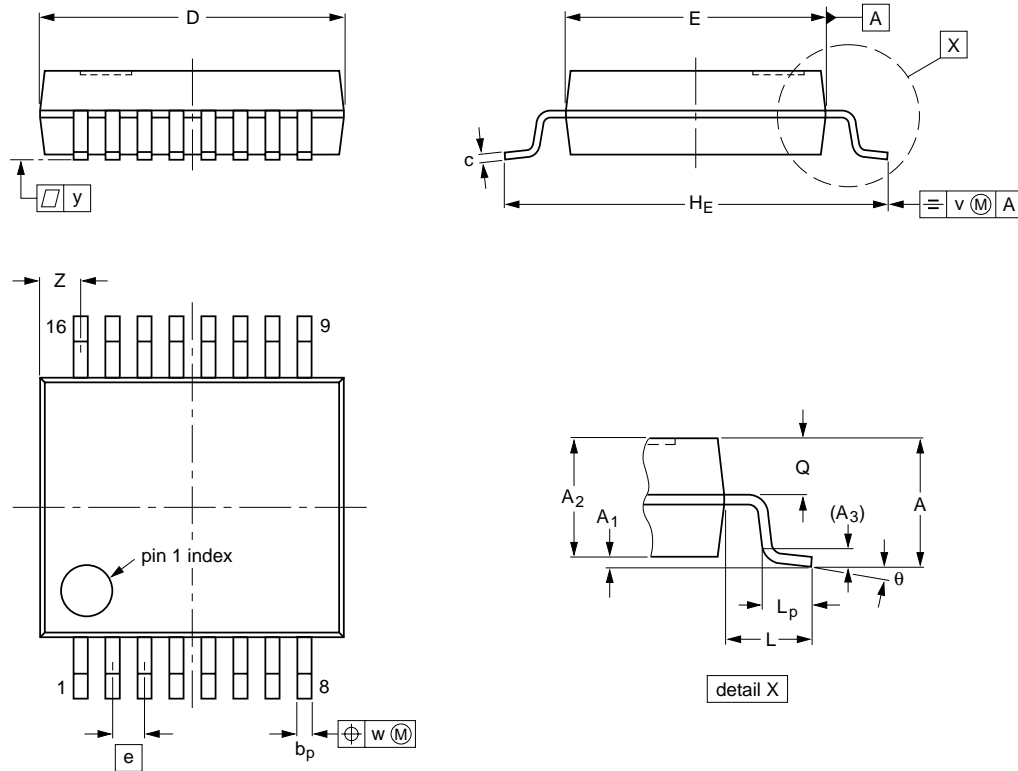

**DIMENSIONS (mm are the original dimensions)**

UNIT	A <sub>max.</sub>	A <sub>1</sub>	A <sub>2</sub>	A <sub>3</sub>	b <sub>p</sub>	c	D <sup>(1)</sup>	E <sup>(1)</sup>	e	H <sub>E</sub>	L	L <sub>p</sub>	Q	v	w	y	Z <sup>(1)</sup>	θ
mm	2.0	0.21 0.05	1.80 1.65	0.25	0.38 0.25	0.20 0.09	6.4 6.0	5.4 5.2	0.65	7.9 7.6	1.25	1.03 0.63	0.9 0.7	0.2	0.13	0.1	1.00 0.55	8° 0°

**Note**

1. Plastic or metal protrusions of 0.25 mm maximum per side are not included.

OUTLINE VERSION	REFERENCES				EUROPEAN PROJECTION	ISSUE DATE
	IEC	JEDEC	EIAJ			
SOT338-1		MO-150AC				94-01-14 95-02-04

# Package outline drawings

**SSOP20: plastic shrink small outline package; 20 leads; body width 5.3 mm**

**SOT339-1**

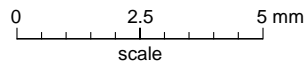
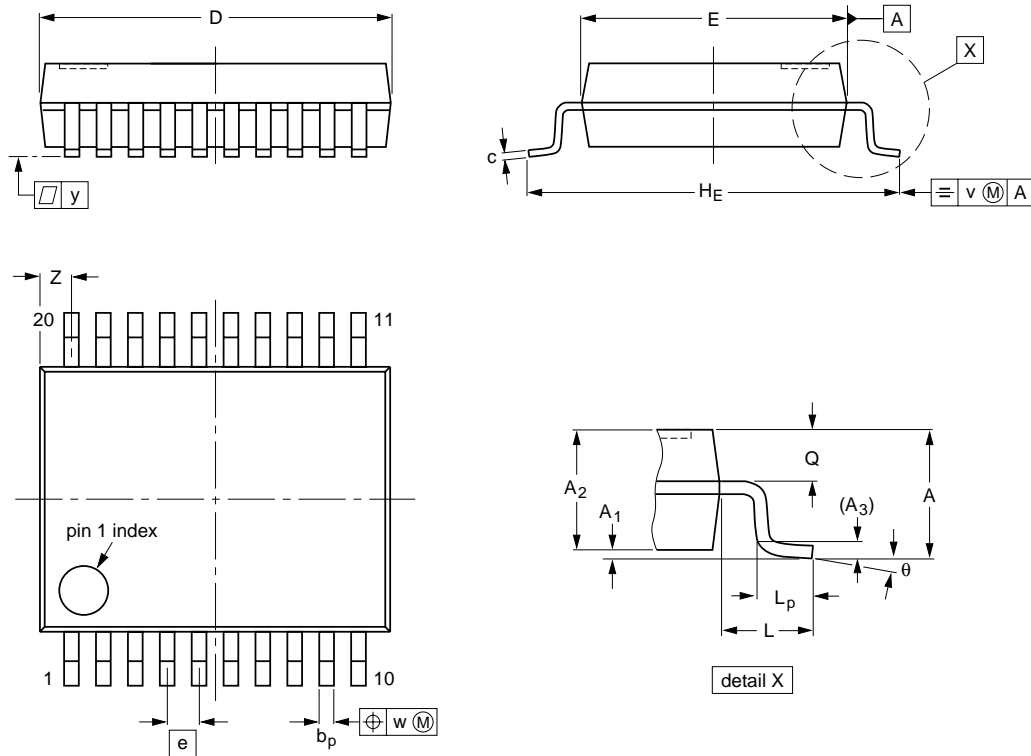

**DIMENSIONS (mm are the original dimensions)**

UNIT	A max.	A <sub>1</sub>	A <sub>2</sub>	A <sub>3</sub>	b <sub>p</sub>	c	D <sup>(1)</sup>	E <sup>(1)</sup>	e	H <sub>E</sub>	L	L <sub>p</sub>	Q	v	w	y	Z <sup>(1)</sup>	θ
mm	2.0	0.21 0.05	1.80 1.65	0.25	0.38 0.25	0.20 0.09	7.4 7.0	5.4 5.2	0.65	7.9 7.6	1.25	1.03 0.63	0.9 0.7	0.2	0.13	0.1	0.9 0.5	8° 0°

**Note**

1. Plastic or metal protrusions of 0.20 mm maximum per side are not included.

OUTLINE VERSION	REFERENCES				EUROPEAN PROJECTION	ISSUE DATE
	IEC	JEDEC	EIAJ			
SOT339-1		MO-150AE				93-09-08- 95-02-04

# Package outline drawings

SSOP24: plastic shrink small outline package; 24 leads; body width 5.3 mm

SOT340-1

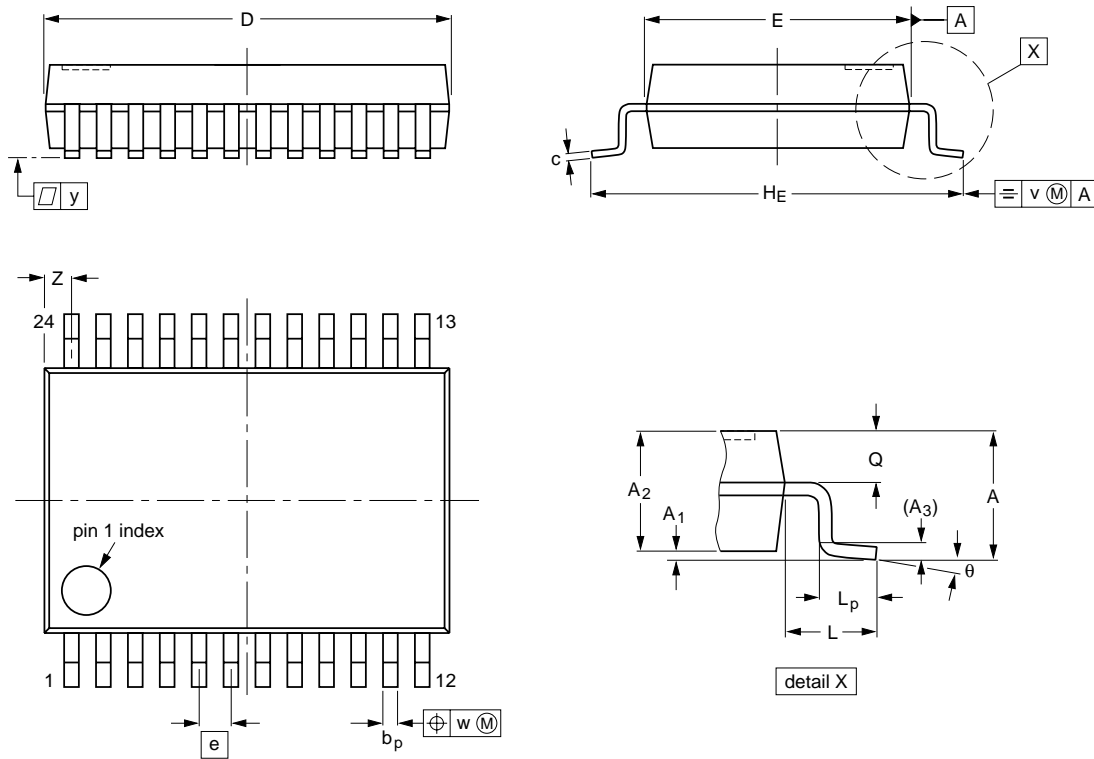

**DIMENSIONS (mm are the original dimensions)**

UNIT	A max.	A <sub>1</sub>	A <sub>2</sub>	A <sub>3</sub>	b <sub>p</sub>	c	D <sup>(1)</sup>	E <sup>(1)</sup>	e	H <sub>E</sub>	L	L <sub>p</sub>	Q	v	w	y	Z <sup>(1)</sup>	θ
mm	2.0	0.21 0.05	1.80 1.65	0.25	0.38 0.25	0.20 0.09	8.4 8.0	5.4 5.2	0.65	7.9 7.6	1.25	1.03 0.63	0.9 0.7	0.2	0.13	0.1	0.8 0.4	8° 0°

**Note**

1. Plastic or metal protrusions of 0.20 mm maximum per side are not included.

OUTLINE VERSION	REFERENCES				EUROPEAN PROJECTION	ISSUE DATE
	IEC	JEDEC	EIAJ			
SOT340-1		MO-150AG				93-09-08 95-02-04

# Package outline drawings

## TSSOP

TSSOP14: plastic thin shrink small outline package; 14 leads; body width 4.4 mm

SOT402-1

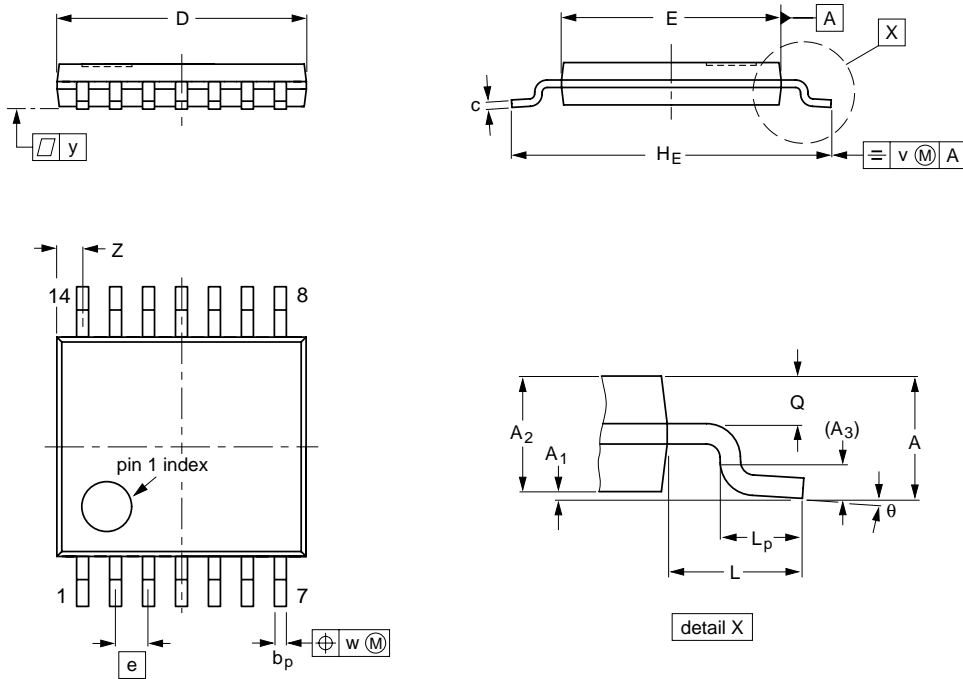

**DIMENSIONS (mm are the original dimensions)**

UNIT	A <sub>max.</sub>	A <sub>1</sub>	A <sub>2</sub>	A <sub>3</sub>	b <sub>p</sub>	c	D <sup>(1)</sup>	E <sup>(2)</sup>	e	H <sub>E</sub>	L	L <sub>p</sub>	Q	v	w	y	z <sup>(1)</sup>	θ
mm	1.10	0.15 0.05	0.95 0.80	0.25	0.30 0.19	0.2 0.1	5.1 4.9	4.5 4.3	0.65	6.6 6.2	1.0	0.75 0.50	0.4 0.3	0.2	0.13	0.1	0.72 0.38	8° 0°

**Notes**

1. Plastic or metal protrusions of 0.15 mm maximum per side are not included.
2. Plastic interlead protrusions of 0.25 mm maximum per side are not included.

OUTLINE VERSION	REFERENCES				EUROPEAN PROJECTION	ISSUE DATE
	IEC	JEDEC	EIAJ			
SOT402-1		MO-153				94-07-12 95-04-04

# Package outline drawings

TSSOP16: plastic thin shrink small outline package; 16 leads; body width 4.4 mm

SOT403-1

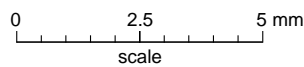
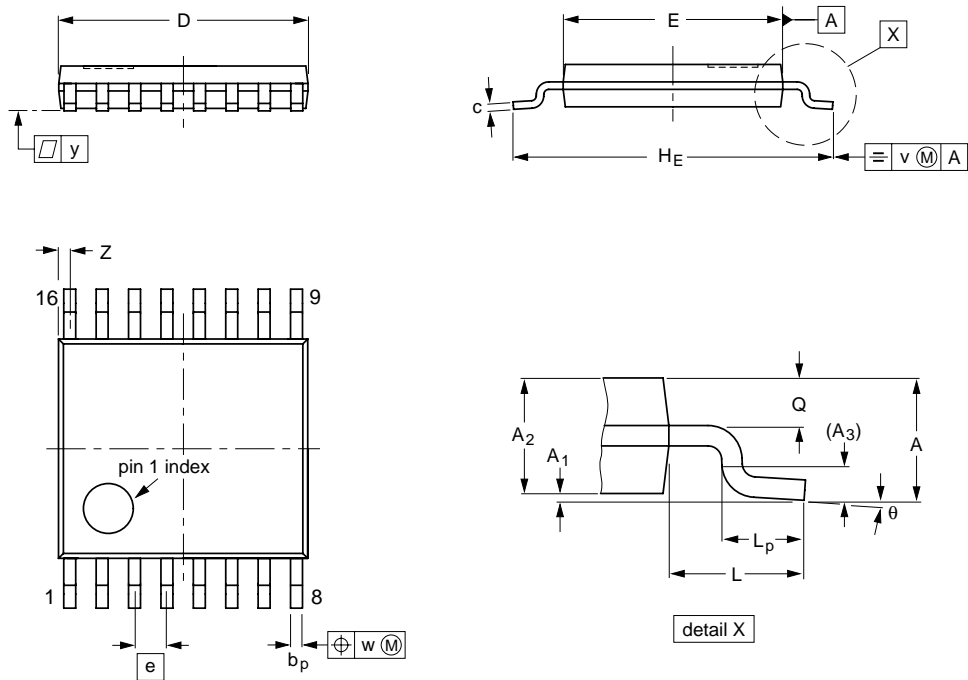

**DIMENSIONS (mm are the original dimensions)**

UNIT	A max.	A <sub>1</sub>	A <sub>2</sub>	A <sub>3</sub>	b <sub>p</sub>	c	D <sup>(1)</sup>	E <sup>(2)</sup>	e	H <sub>E</sub>	L	L <sub>p</sub>	Q	v	w	y	Z <sup>(1)</sup>	θ
mm	1.10	0.15 0.05	0.95 0.80	0.25	0.30 0.19	0.2 0.1	5.1 4.9	4.5 4.3	0.65	6.6 6.2	1.0	0.75 0.50	0.4 0.3	0.2	0.13	0.1	0.40 0.06	8° 0°

**Notes**

1. Plastic or metal protrusions of 0.15 mm maximum per side are not included.
2. Plastic interlead protrusions of 0.25 mm maximum per side are not included.

OUTLINE VERSION	REFERENCES				EUROPEAN PROJECTION	ISSUE DATE
	IEC	JEDEC	EIAJ			
SOT403-1		MO-153				-94-07-12- 95-04-04

# Package outline drawings

TSSOP20: plastic thin shrink small outline package; 20 leads; body width 4.4 mm

SOT360-1

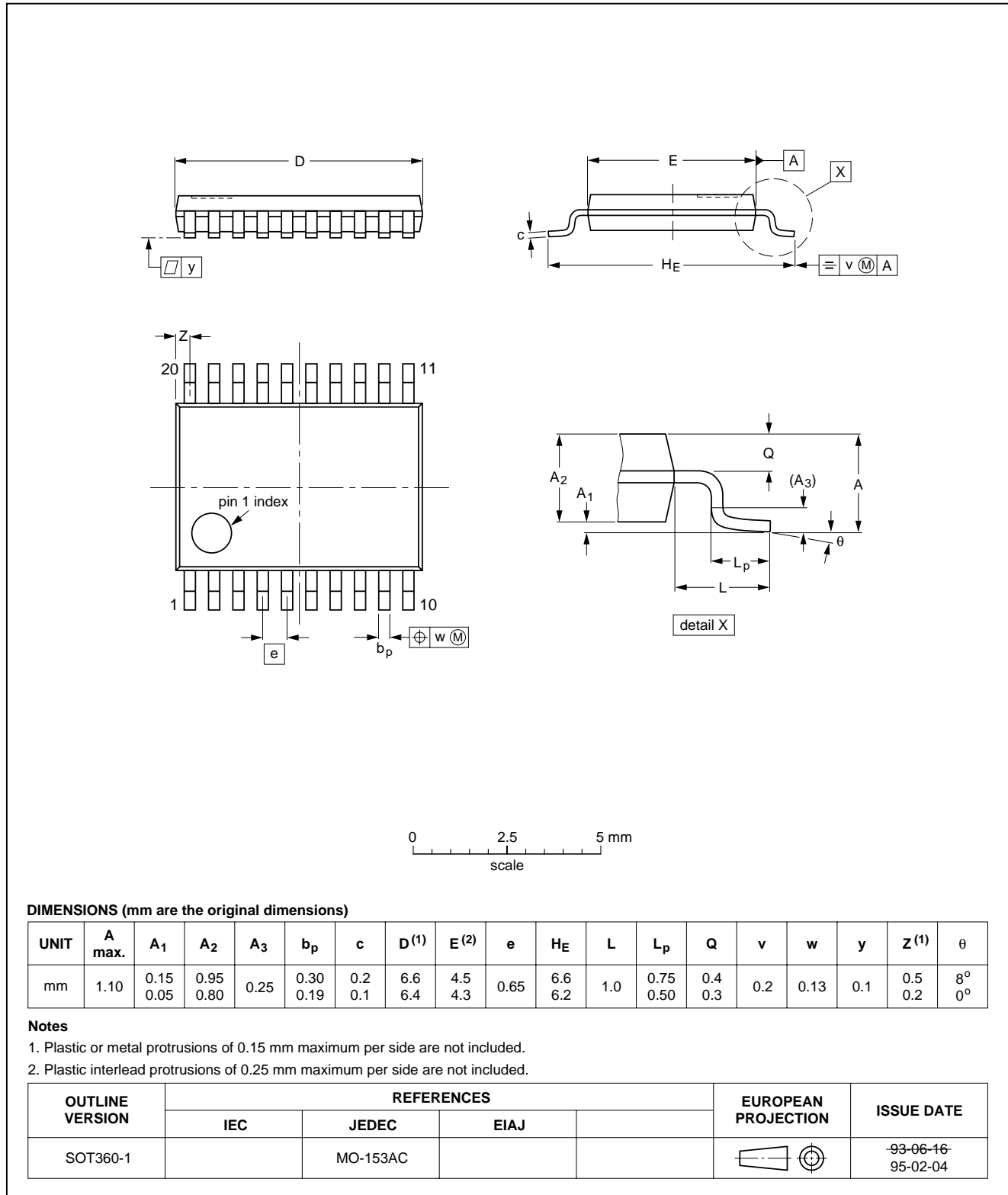

# Package outline drawings

TSSOP24: plastic thin shrink small outline package; 24 leads; body width 4.4 mm

SOT355-1

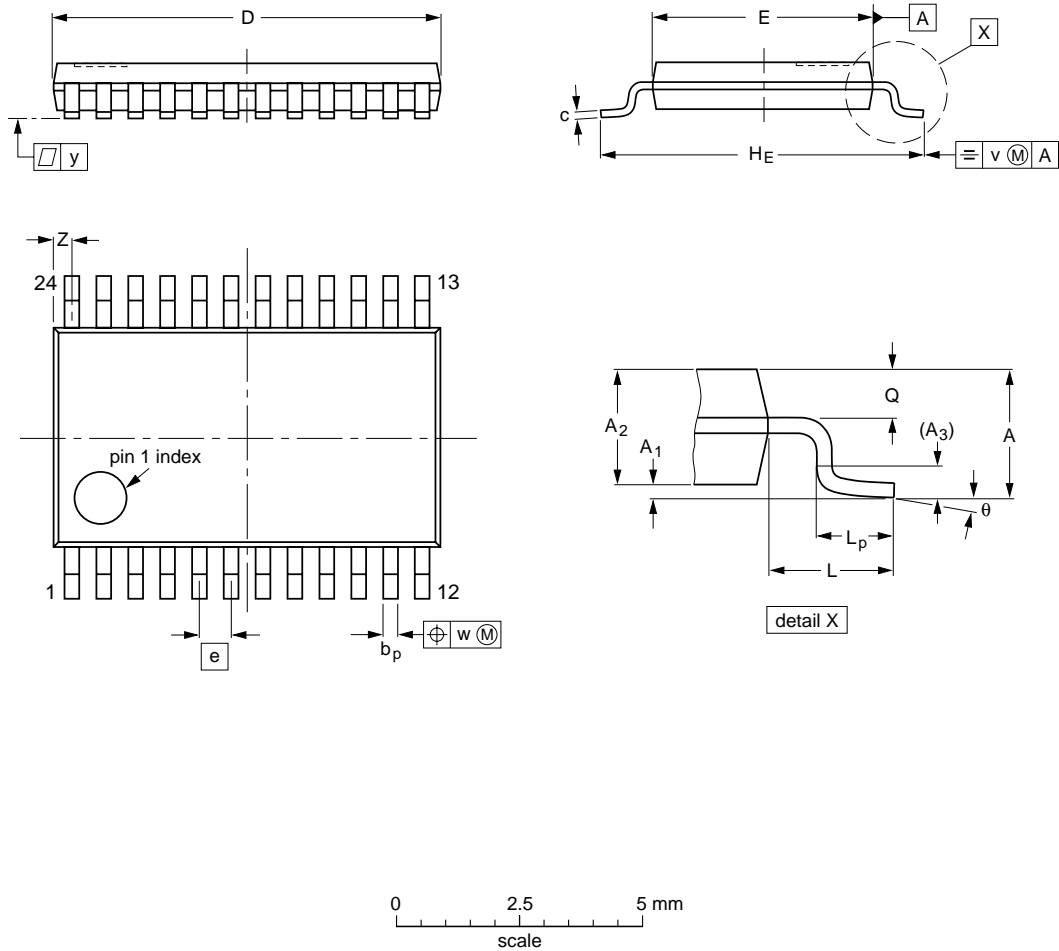

**DIMENSIONS (mm are the original dimensions)**

UNIT	A max.	A <sub>1</sub>	A <sub>2</sub>	A <sub>3</sub>	b <sub>p</sub>	c	D <sup>(1)</sup>	E <sup>(2)</sup>	e	H <sub>E</sub>	L	L <sub>p</sub>	Q	v	w	y	Z <sup>(1)</sup>	θ
mm	1.10	0.15 0.05	0.95 0.80	0.25	0.30 0.19	0.2 0.1	7.9 7.7	4.5 4.3	0.65	6.6 6.2	1.0	0.75 0.50	0.4 0.3	0.2	0.13	0.1	0.5 0.2	8° 0°

**Notes**

1. Plastic or metal protrusions of 0.15 mm maximum per side are not included.
2. Plastic interlead protrusions of 0.25 mm maximum per side are not included.

OUTLINE VERSION	REFERENCES				EUROPEAN PROJECTION	ISSUE DATE
	IEC	JEDEC	EIAJ			
SOT355-1		MO-153AD				93-06-16 95-02-04



# Package information

Supersedes data of 2001 Nov 02  
File under Integrated Circuits, IC06

2002 Aug 08

## Package information

### PACKAGE INFORMATION

<i>PART NUMBER</i>	<i>DIL (N)</i>	<i>SO (D)</i>	<i>SSOP (DB)</i>	<i>TSSOP (PW)</i>	<i>PIN COUNT</i>
74HCU04	27-1	108-1	337-1	402-1	14
74HCTU04	27-1	108-1			14
74HC00	27-1	108-1	337-1	402-1	14
74HCT00	27-1	108-1	337-1	402-1	14
74HC02	27-1	108-1	337-1	402-1	14
74HCT02	27-1	108-1	337-1	402-1	14
74HC03	27-1	108-1	337-1	402-1	14
74HCT03	27-1	108-1	337-1	402-1	14
74HC04	27-1	108-1	337-1	402-1	14
74HCT04	27-1	108-1	337-1	402-1	14
74HC08	27-1	108-1	337-1	402-1	14
74HCT08	27-1	108-1	337-1	402-1	14
74HC10	27-1	108-1	337-1	402-1	14
74HCT10	27-1	108-1	337-1	402-1	14
74HC42	38-4	109-1			16
74HCT42	38-4	109-1			16
74HC107	27-1	108-1	337-1	402-1	14
74HCT107	27-1	108-1	337-1	402-1	14
74HC109	38-4	109-1			16
74HCT109	38-4	109-1	338-1		16
74HC11	27-1	108-1	337-1	402-1	14
74HCT11	27-1	108-1	337-1	402-1	14
74HC112	38-4	109-1	338-1	403-1	16
74HCT112	38-4	109-1	338-1	403-1	16
74HC123	38-4	109-1	338-1	403-1	16
74HCT123	38-4	109-1	338-1	403-1	16
74HC125	27-1	108-1	337-1	402-1	14
74HCT125	27-1	108-1	337-1	402-1	14
74HC126	27-1	108-1	337-1	402-1	14
74HCT126	27-1	108-1	337-1	402-1	14
74HC132	27-1	108-1	337-1	402-1	14
74HCT132	27-1	108-1	337-1	402-1	14
74HC133	27-1	108-1			16
74HCT133	27-1	108-1			16
74HC137	38-4	109-1	338-1		16
74HCT137	38-4	109-1			16
74HC138	38-4	109-1	338-1	403-1	16
74HCT138	38-4	109-1	338-1	403-1	16
74HC139	38-4	109-1	338-1	403-1	16

## Package information

<b>PART NUMBER</b>	<b>DIL (N)</b>	<b>SO (D)</b>	<b>SSOP (DB)</b>	<b>TSSOP (PW)</b>	<b>PIN COUNT</b>
74HCT139	38-4	109-1	338-1	403-1	16
74HC14	27-1	108-1	337-1	402-1	14
74HCT14	27-1	108-1	337-1	402-1	14
74HC147	38-4	109-1	338-1		16
74HCT147	38-4	109-1	338-1		16
74HC151	38-4	109-1	338-1	403-1	16
74HCT151	38-4	109-1	338-1	403-1	16
74HC153	38-4	109-1	338-1	403-1	16
74HCT153	38-4	109-1	338-1	403-1	16
74HC154	101-1	137-1	340-1	355-1	24
74HCT154	101-1	137-1	340-1	355-1	24
74HC157	38-4	109-1	338-1	403-1	16
74HCT157	38-4	109-1	338-1	403-1	16
74HC158	38-4	109-1			16
74HCT158	38-4	109-1			16
74HC160	38-4	109-1	338-1		16
74HCT160	38-4	109-1			16
74HC161	38-4	109-1	338-1	403-1	16
74HCT161	38-4	109-1	338-1	403-1	16
74HC162	38-4	109-1			16
74HCT162	38-4	109-1			16
74HC163	38-4	109-1	338-1	403-1	16
74HCT163	38-4	109-1	338-1	403-1	16
74HC164	27-1	108-1	337-1	402-1	14
74HCT164	27-1	108-1	337-1	402-1	14
74HC165	38-4	109-1	338-1	403-1	16
74HCT163	38-4	109-1	338-1	403-1	16
74HC164	27-1	108-1	337-1	402-1	16
74HCT164	27-1	108-1	337-1	402-1	16
74HC165	38-4	109-1	338-1	403-1	16
74HCT165	38-4	109-1	338-1	403-1	16
74HC166	38-4	109-1	338-1	403-1	16
74HCT166	38-4	109-1	338-1		16
74HC173	38-4	109-1	338-1	403-1	16
74HCT173	38-4	109-1	338-1		16
74HC174	38-4	109-1	338-1	403-1	16
74HCT174	38-4	109-1	338-1	403-1	16
74HC175	38-4	109-1	338-1	403-1	16
74HCT175	38-4	109-1	338-1	403-1	16

## Package information

<i>PART NUMBER</i>	<i>DIL (N)</i>	<i>SO (D)</i>	<i>SSOP (DB)</i>	<i>TSSOP (PW)</i>	<i>PIN COUNT</i>
74HC181	101-1	137-1			24
74HCT181	101-1	137-1			24
74HC182	38-4	109-1			16
74HCT182	38-4	109-1			16
74HC190	38-4	109-1			16
74HCT190	38-4	109-1			16
74HC191	38-4	109-1	338-1	403-1	16
74HCT191	38-4	109-1			16
74HC192	38-4	109-1	338-1		16
74HCT192	38-4	109-1			16
74HC193	38-4	109-1	338-1	403-1	16
74HCT193	38-4	109-1	338-1		16
74HC194	38-4	109-1	338-1		16
74HCT194	38-4	109-1	338-1		16
74HC195	38-4	109-1	338-1		16
74HCT195	38-4	109-1	338-1		16
74HC20	27-1	108-1	337-1	402-1	14
74HCT20	27-1	108-1	337-1		14
74HC21	27-1	108-1	337-1		14
74HCT21	27-1	108-1	337-1		14
74HC221	38-4	109-1	338-1		16
74HCT221	38-4	109-1	338-1		16
74HC237	38-4	109-1	338-1		16
74HCT237	38-4	109-1	338-1		16
74HC238	38-4	109-1	338-1	403-1	16
74HCT238	38-4	109-1	338-1	403-1	16
74HC240	146-1	163-1	339-1	360-1	20
74HCT240	146-1	163-1	339-1	360-1	20
74HC241	146-1	163-1	339-1	360-1	20
74HCT241	146-1	163-1	339-1	360-1	20
74HC242	27-1	108-1	337-1		14
74HCT242	27-1	108-1			14
74HC243	27-1	108-1	337-1		14
74HCT243	27-1	108-1	337-1		14
74HC244	146-1	163-1	339-1	360-1	20
74HCT244	146-1	163-1	339-1	360-1	20
74HC245	146-1	163-1	339-1	360-1	20
74HCT245	146-1	163-1	339-1	360-1	20

## Package information

<i>PART NUMBER</i>	<i>DIL (N)</i>	<i>SO (D)</i>	<i>SSOP (DB)</i>	<i>TSSOP (PW)</i>	<i>PIN COUNT</i>
74HC251	38-4	109-1	338-1	403-1	16
74HCT251	38-4	109-1	338-1	403-1	16
74HC253	38-4	109-1	338-1		16
74HCT253	38-4	109-1	338-1		16
74HC257	38-4	109-1	338-1	403-1	16
74HCT257	38-4	109-1	338-1	403-1	16
74HC258	38-4	109-1	338-1		16
74HCT258	38-4	109-1			16
74HC259	38-4	109-1	338-1	403-1	16
74HCT259	38-4	109-1	338-1	403-1	16
74HC27	38-4	109-1	338-1	403-1	16
74HCT27	38-4	109-1	338-1	403-1	16
74HC273	146-1	163-1	339-1	360-1	20
74HCT273	146-1	163-1	339-1	360-1	20
74HC280	27-1	108-1	337-1	402-1	14
74HCT280	27-1	108-1		402-1	14
74HC283	38-4	109-1	338-1	403-1	16
74HCT283	38-4	109-1	338-1	403-1	16
74HC297	38-4	109-1			16
74HCT297	38-4	109-1			16
74HC299	146-1	163-1	339-1		20
74HCT299	146-1	163-1	339-1		20
74HC30	27-1	108-1	337-1	402-1	14
74HCT30	27-1	108-1	337-1	402-1	14
74HC32	27-1	108-1	337-1	402-1	14
74HCT32	27-1	108-1	337-1	402-1	14
74HC354	146-1	163-1			20
74HCT354	146-1	163-1			20
74HC356	146-1	163-1			20
74HCT356	146-1	163-1			20
74HC365	38-4	109-1	338-1	403-1	16
74HCT365	38-4	109-1	338-1		16
74HC366	38-4	109-1			16
74HCT366	38-4	109-1	338-1		16
74HC367	38-4	109-1	338-1	403-1	16
74HCT367	38-4	109-1	338-1	403-1	16
74HC368	38-4	109-1	338-1		16
74HCT368	38-4	109-1	338-1	403-1	16

## Package information

<b>PART NUMBER</b>	<b>DIL (N)</b>	<b>SO (D)</b>	<b>SSOP (DB)</b>	<b>TSSOP (PW)</b>	<b>PIN COUNT</b>
74HC373	146-1	163-1	339-1	360-1	20
74HCT373	146-1	163-1	339-1	360-1	20
74HCT374	146-1	163-1	339-1	360-1	20
74HC374	146-1	163-1	339-1	360-1	20
74HCT377	146-1	163-1	339-1	360-1	20
74HC377	146-1	163-1	339-1	360-1	20
74HC390	38-4	109-1	338-1	403-1	16
74HCT390	38-4	109-1	338-1		16
74HC393	27-1	108-1	337-1	402-1	14
74HCT393	27-1	108-1	337-1	402-1	14
74HC4002	27-1	108-1	337-1	402-1	14
74HCT4002	27-1	108-1	337-1		14
74HC4015	38-4	109-1			16
74HCT4015	38-4	109-1			16
74HC4016	38-4	109-1			16
74HCT4016	38-4	109-1			16
74HC4017	38-4	109-1			16
74HCT4017	38-4	109-1			16
74HC40102	38-4	109-1			16
74HCT40102	38-4	109-1			16
74HC40103	38-4	109-1	338-1	403-1	16
74HCT40103	38-4	109-1	338-1		16
74HC40104	38-4	109-1			16
74HCT40104	38-4	109-1			16
74HC40105	38-4	109-1	338-1	403-1	16
74HCT40105	38-4	109-1	338-1		16
74HC4020	38-4	109-1	338-1	403-1	16
74HCT4020	38-4	109-1	338-1	403-1	16
74HC4024	27-1	108-1	337-1		14
74HCT4024	27-1	108-1			14
74HC4040	38-4	109-1	338-1	403-1	16
74HCT4024	27-1	108-1			16
74HC4046A	38-4	109-1	338-1	403-1	16
74HCT4046A	38-4	109-1	338-1		16
74HC4049	38-4	109-1			16
74HCT4049	38-4	109-1			16
74HC4059	101-1	137-1			24
74HCT4059	101-1	137-1			24

## Package information

<i>PART NUMBER</i>	<i>DIL (N)</i>	<i>SO (D)</i>	<i>SSOP (DB)</i>	<i>TSSOP (PW)</i>	<i>PIN COUNT</i>
74HC4050	38-4	109-1	338-1	403-1	16
74HCT4050	38-4	109-1			16
74HC4051	38-4	109-1	338-1	403-1	16
74HCT4051	38-4	109-1	338-1		16
74HC4052	38-4	109-1	338-1	403-1	16
74HCT4052	38-4	109-1	338-1		16
74HC4053	38-4	109-1	338-1	403-1	16
74HCT4053	38-4	109-1	338-1	403-1	16
74HC4060	38-4	109-1	338-1	403-1	16
74HCT4060	38-4	109-1	338-1		16
74HCT4066	101-1	137-1	340-1	355-1	24
74HC4066	101-1	137-1	340-1	355-1	24
74HC4067	101-1	137-1	340-1	355-1	24
74HCT4067	101-1	137-1	340-1	355-1	24
74HC4075	27-1	108-1	337-1		14
74HCT4075	27-1	108-1	337-1	402-1	14
74HC4094	38-4	109-1	338-1		16
74HCT4094	38-4	109-1	338-1		16
74HC423	38-4	109-1			16
74HCT423	38-4	109-1			16
74HC4316	38-4	109-1	338-1	403-1	16
74HCT4316	38-4	109-1	338-1	403-1	16
74HC4351	146-1	163-1	339-1		20
74HCT4351	146-1	163-1	339-1		20
74HC4352	146-1	163-1			20
74HCT4352	146-1	163-1			20
74HC4510	38-4	109-1			16
74HCT4510	38-4	109-1			16
74HC4511	38-4	109-1			16
74HCT4511	38-4	109-1			16
74HC4515	101-1	137-1			24
74HCT4515	101-1	137-1			24
74HC4516	38-4	109-1			16
74HCT4516	38-4	109-1			16
74HC4514	101-1	137-1	340-1		24

## Package information

<i>PART NUMBER</i>	<i>DIL (N)</i>	<i>SO (D)</i>	<i>SSOP (DB)</i>	<i>TSSOP (PW)</i>	<i>PIN COUNT</i>
74HCT4514	101-1	137-1	340-1		24
74HC4518	38-4	109-1			16
74HCT4518	38-4	109-1			16
74HC4520	38-4	109-1	338-1	403-1	16
74HCT4520	38-4	109-1	338-1		16
74HC4538	38-4	109-1	338-1	403-1	16
74HCT4538	38-4	109-1	338-1	403-1	16
74HC4543	38-4	109-1			16
74HCT4543	38-4	109-1			16
74HC533	146-1	163-1			20
74HCT533	146-1	163-1			20
74HC534	146-1	163-1			20
74HCT534	146-1	163-1			20
74HC540	146-1	163-1	339-1		20
74HCT540	146-1	163-1	339-1		20
74HC541	146-1	163-1	339-1	360-1	20
74HCT541	146-1	163-1	339-1	360-1	20
74HC5555	38-4	109-1			16
74HCT5555	38-4	109-1			16
74HC563	146-1	163-1			20
74HCT563	146-1	163-1	339-1		20
74HC564	146-1	163-1			20
74HCT564	146-1	163-1			20
74HC573	146-1	163-1	339-1	360-1	20
74HCT573	146-1	163-1	339-1	360-1	20
74HC574	146-1	163-1	339-1	360-1	20
74HCT574	146-1	163-1	339-1	360-1	20
74HC58	27-1	108-1	337-1		14
74HC583	38-4	109-1			16
74HCT583	38-4	109-1			16
74HC594	38-4	109-1	338-1		16
74HCT594	38-4	109-1			16
74HC595	38-4	109-1	338-1	403-1	16
74HCT595	38-4	109-1	338-1	403-1	16
74HC597	38-4	109-1	338-1	403-1	16
74HCT597	38-4	109-1	338-1		16
74HC6323A		96-1			8
74HCT6323A		96-1			8



## Package information

<i>PART NUMBER</i>	<i>DIL (N)</i>	<i>SO (D)</i>	<i>SSOP (DB)</i>	<i>TSSOP (PW)</i>	<i>PIN COUNT</i>
74HC640	146-1	163-1	339-1		20
74HCT640	146-1	163-1	339-1		20
74HC643	146-1	163-1			20
74HCT643	146-1	163-1			20
74HC646	101-1	137-1	340-1		24
74HCT646	101-1	137-1	340-1		24
74HC648	101-1	137-1			24
74HCT648	101-1	137-1			24
74HC652	101-1	137-1			24
74HCT652	101-1	137-1			24
74HC670	38-4	109-1	338-1		16
74HCT670	38-4	109-1	338-1		16
74HC688	146-1	163-1	339-1	360-1	20
74HCT688	146-1	163-1	339-1	360-1	20
74HC7014	27-1	108-1			14
74HCT7014	27-1	108-1			14
74HC7030	117-1	136-1			28
74HCT7030	117-1	136-1			28
74HC7046A	38-4	109-1	338-1		16
74HCT7046A	38-4	109-1			16
74HC7080	146-1	163-1			20
74HCT7080	146-1	163-1			20
74HC7132	27-1	108-1			14
74HCT7132	27-1	108-1			14
74HC7245	146-1	163-1			20
74HCT7245	146-1	163-1			20
74HC7266	27-1	108-1	337-1		14
74HCT7266	27-1	108-1			14
74HC73	27-1	108-1			14
74HCT73	27-1	108-1	337-1		14
74HC74	27-1	108-1			14
74HCT74	27-1	108-1	337-1	402-1	14
74HC7403	38-4	109-1			16
74HCT7403	38-4	109-1			16
74HC7404	102-1	163-1			18 / 20
74HCT7404	102-1	163-1			18 / 20
74HC75	38-4	109-1	338-1	403-1	16
74HCT75	38-4	109-1	338-1		16

## Package information

<b>PART NUMBER</b>	<b>DIL (N)</b>	<b>SO (D)</b>	<b>SSOP (DB)</b>	<b>TSSOP (PW)</b>	<b>PIN COUNT</b>
74HC7540	146-1	163-1	339-1		20
74HCT7540	146-1	163-1			20
74HC7541	146-1	163-1	339-1		20
74HCT7541	146-1	163-1			20
74HC7597	38-4	109-1			16
74HC7597	38-4	109-1			16
74HC7731	38-4	109-1			16
74HCT7731	38-4	109-1			16
74HC85	38-4	109-1	338-1	403-1	16
74HCT85	38-4	109-1	338-1		16
74HC86	27-1	108-1	337-1	402-1	14
74HC86	27-1	108-1	337-1	402-1	14
74HC9014	146-1	163-1			20
74HCT9014	146-1	163-1			20
74HC9015	146-1	163-1		360-1	20
74HCT9015	146-1	163-1			20
74HC9046A	38-4	109-1			16
74HCT9046A	38-4	109-1		403-1	16
74HC9114	146-1	163-1			20
74HCT9114	146-1	163-1			20
74HC9115	146-1	163-1			20
74HCT9115	146-1	163-1			20
74HC93	27-1	108-1	337-1		14
74HCT93	27-1	108-1			14
74HC9323A		96-1			8
74HCT9323A		96-1			8
74HCT1284	146-1	163-1	339-1	360-1	20

*Let's make things better.*

## HCMOS family characteristics

## FAMILY SPECIFICATIONS

### GENERAL

These family specifications cover the common electrical ratings and characteristics of the entire HCMOS 74HC/HCT/HCU family, unless otherwise specified in the individual device data sheet.

### INTRODUCTION

The 74HC/HCT/HCU high-speed Si-gate CMOS logic family combines the low power advantages of the HE4000B family with the high speed and drive capability of the low power Schottky TTL (LSTTL).

The family will have the same pin-out as the 74 series and provide the same circuit functions.

In these families are included several HE4000B family circuits which do not have TTL counterparts, and some special circuits.

The basic family of buffered devices, designated as XX74HCXXXXX, will operate at CMOS input logic levels for high noise immunity, negligible typical quiescent supply and input current. It is operated from a power supply of 2 to 6 V.

A subset of the family, designated as XX74HCTXXXXX, with the same features and functions as the "HC-types", will operate at standard TTL power supply voltage ( $5\text{ V} \pm 10\%$ ) and logic input levels (0.8 to 2.0 V) for use as pin-to-pin compatible CMOS replacements to reduce power consumption without loss of speed. These types are also suitable for converted switching from TTL to CMOS.

Another subset, the XX74HCUXXXXX, consists of single-stage unbuffered CMOS compatible devices for application in RC or crystal controlled oscillators and other types of feedback circuits which operate in the linear mode.

### HANDLING MOS DEVICES

Inputs and outputs are protected against electrostatic effects in a wide variety of device-handling situations. However, to be totally safe, it is desirable to take handling precautions into account (see also "HANDLING PRECAUTIONS").

### RECOMMENDED OPERATING CONDITIONS FOR 74HC/HCT

SYMBOL	PARAMETER	74HC			74HCT			UNIT	CONDITIONS
		min.	typ.	max.	min.	typ.	max.		
$V_{CC}$	DC supply voltage	2.0	5.0	6.0	4.5	5.0	5.5	V	
$V_I$	DC input voltage range	0		$V_{CC}$	0		$V_{CC}$	V	
$V_O$	DC output voltage range	0		$V_{CC}$	0		$V_{CC}$	V	
$T_{amb}$	operating ambient temperature range	-40		+85	-40		+85	°C	see DC and AC CHAR. per device
$T_{amb}$	operating ambient temperature range	-40		+125	-40		+125	°C	
$t_r, t_f$	input rise and fall times except for Schmitt-trigger inputs		6.0	1000 500 400		6.0	500	ns	$V_{CC} = 2.0\text{ V}$ $V_{CC} = 4.5\text{ V}$ $V_{CC} = 6.0\text{ V}$

### Note

- For analog switches, e.g. "4016", "4051 series", "4351 series", "4066" and "4067", the specified maximum operating supply voltage is 10 V.

## HCMOS family characteristics

## FAMILY SPECIFICATIONS

## RECOMMENDED OPERATING CONDITIONS FOR 74HCU

SYMBOL	PARAMETER	74HCU			UNIT	CONDITIONS
		min.	typ.	max.		
$V_{CC}$	DC supply voltage	2.0	5.0	6.0	V	
$V_I$	DC input voltage range	0		$V_{CC}$	V	
$V_O$	DC output voltage range	0		$V_{CC}$	V	
$T_{amb}$	operating ambient temperature range	-40		+85	°C	see DC and AC CHAR. per device
$T_{amb}$	operating ambient temperature range	-40		+125	°C	

## RATINGS

Limiting values in accordance with the Absolute Maximum System (IEC 134)

Voltages are referenced to GND (ground = 0 V)

SYMBOL	PARAMETER	MIN.	MAX.	UNIT	CONDITIONS
$V_{CC}$	DC supply voltage	-0.5	+7	V	
$\pm I_{IK}$	DC input diode current		20	mA	for $V_I < -0.5$ or $V_I > V_{CC} + 0.5$ V
$\pm I_{OK}$	DC output diode current		20	mA	for $V_O < -0.5$ or $V_O > V_{CC} + 0.5$ V
$\pm I_O$	DC output source or sink current				for $-0.5$ V $< V_O < V_{CC} + 0.5$ V
	standard outputs		25	mA	
	bus driver outputs		35	mA	
$\pm I_{CC};$ $\pm I_{GND}$	DC $V_{CC}$ or GND current for types with:				
	standard outputs		50	mA	
	bus driver outputs		70	mA	
$T_{stg}$	storage temperature range	-65	+150	°C	
$P_{tot}$	power dissipation per package				for temperature range: -40 to +125 °C 74HC/HCT/HCU
	plastic DIL		750	mW	above +70 °C: derate linearly with 12 mW/K
	plastic mini-pack (SO)		500	mW	above +70 °C: derate linearly with 8 mW/K

## Note

- For analog switches, e.g. "4016", "4051 series", "4351 series", "4066" and "4067", the specified maximum operating supply voltage is 11 V.

## HCMOS family characteristics

## FAMILY SPECIFICATIONS

## DC CHARACTERISTICS FOR 74HC

Voltages are referenced to GND (ground = 0 V)

SYMBOL	PARAMETER	$T_{amb}$ (°C)							UNIT	TEST CONDITIONS		
		74HC								$V_{CC}$ (V)	$V_I$	OTHER
		+25			-40 to +85		-40 to +125					
		min.	typ.	max.	min.	max.	min.	max.				
$V_{IH}$	HIGH level input voltage	1.5 3.15 4.2	1.2 2.4 3.2		1.5 3.15 4.2		1.5 3.15 4.2		V	2.0 4.5 6.0		
$V_{IL}$	LOW level input voltage		0.8 2.1 2.8	0.5 1.35 1.8		0.5 1.35 1.8		0.5 1.35 1.8	V	2.0 4.5 6.0		
$V_{OH}$	HIGH level output voltage all outputs	1.9 4.4 5.9	2.0 4.5 6.0		1.9 4.4 5.9		1.9 4.4 5.9		V	2.0 4.5 6.0	$V_{IH}$ or $V_{IL}$	$-I_O = 20 \mu A$ $-I_O = 20 \mu A$ $-I_O = 20 \mu A$
$V_{OH}$	HIGH level output voltage standard outputs	3.98 5.48	4.32 5.81		3.84 5.34		3.7 5.2		V	4.5 6.0	$V_{IH}$ or $V_{IL}$	$-I_O = 4.0 \text{ mA}$ $-I_O = 5.2 \text{ mA}$
$V_{OH}$	HIGH level output voltage bus driver outputs	3.98 5.48	4.32 5.81		3.84 5.34		3.7 5.2		V	4.5 6.0	$V_{IH}$ or $V_{IL}$	$-I_O = 6.0 \text{ mA}$ $-I_O = 7.8 \text{ mA}$
$V_{OL}$	LOW level output voltage all outputs		0 0 0	0.1 0.1 0.1		0.1 0.1 0.1		0.1 0.1 0.1	V	2.0 4.5 6.0	$V_{IH}$ or $V_{IL}$	$I_O = 20 \mu A$ $I_O = 20 \mu A$ $I_O = 20 \mu A$
$V_{OL}$	LOW level output voltage standard outputs		0.15 0.16	0.26 0.26		0.33 0.33		0.4 0.4	V	4.5 6.0	$V_{IH}$ or $V_{IL}$	$I_O = 4.0 \text{ mA}$ $I_O = 5.2 \text{ mA}$
$V_{OL}$	LOW level output voltage bus driver outputs		0.15 0.16	0.26 0.26		0.33 0.33		0.4 0.4	V	4.5 6.0	$V_{IH}$ or $V_{IL}$	$I_O = 6.0 \text{ mA}$ $I_O = 7.8 \text{ mA}$
$\pm I_I$	input leakage current			0.1		1.0		1.0	$\mu A$	6.0	$V_{CC}$ or GND	
$\pm I_{OZ}$	3-state OFF-state current			0.5		5.0		10.0	$\mu A$	6.0	$V_{IH}$ or $V_{IL}$	$V_O = V_{CC}$ or GND
$I_{CC}$	quiescent supply current											
	SSI			2.0		20.0		40.0	$\mu A$	6.0	$V_{CC}$	$I_O = 0$
	flip-flops			4.0		40.0		80.0		6.0	or GND	$I_O = 0$
	MSI			8.0		80.0		160.0		6.0		$I_O = 0$
	LSI			50.0		500		1000		6.0		$I_O = 0$

## HCMOS family characteristics

## FAMILY SPECIFICATIONS

## DC CHARACTERISTICS FOR 74HCT

Voltages are referenced to GND (ground = 0 V)

SYMBOL	PARAMETER	T <sub>amb</sub> (°C)							UNIT	TEST CONDITIONS		
		74HCT								V <sub>CC</sub> (V)	V <sub>I</sub>	OTHER
		+25			-40 to +85		-40 to +125					
		min.	typ.	max.	min.	max.	min.	max.				
V <sub>IH</sub>	HIGH level input voltage	2.0	1.6		2.0		2.0		V	4.5 to 5.5		
V <sub>IL</sub>	LOW level input voltage		1.2	0.8		0.8		0.8	V	4.5 to 5.5		
V <sub>OH</sub>	HIGH level output voltage all outputs	4.4	4.5		4.4		4.4		V	4.5	V <sub>IH</sub> or V <sub>IL</sub>	-I <sub>O</sub> = 20 μA
V <sub>OH</sub>	HIGH level output voltage standard outputs	3.98	4.32		3.84		3.7		V	4.5	V <sub>IH</sub> or V <sub>IL</sub>	-I <sub>O</sub> = 4.0 mA
V <sub>OH</sub>	HIGH level output voltage bus driver outputs	3.98	4.32		3.84		3.7		V	4.5	V <sub>IH</sub> or V <sub>IL</sub>	-I <sub>O</sub> = 6.0 mA
V <sub>OL</sub>	LOW level output voltage all outputs		0	0.1		0.1		0.1	V	4.5	V <sub>IH</sub> or V <sub>IL</sub>	I <sub>O</sub> = 20 μA
V <sub>OL</sub>	LOW level output voltage standard outputs		0.15	0.26		0.33		0.4	V	4.5	V <sub>IH</sub> or V <sub>IL</sub>	I <sub>O</sub> = 4.0 mA
V <sub>OL</sub>	LOW level output voltage bus driver outputs		0.16	0.26		0.33		0.4	V	4.5	V <sub>IH</sub> or V <sub>IL</sub>	I <sub>O</sub> = 6.0 mA
±I <sub>I</sub>	input leakage current			0.1		1.0		1.0	μA	5.5	V <sub>CC</sub> or GND	
±I <sub>OZ</sub>	3-state OFF-state current			0.5		5.0		10.0	μA	5.5	V <sub>IH</sub> or V <sub>IL</sub>	V <sub>O</sub> = V <sub>CC</sub> or GND per input pin; other inputs at V <sub>CC</sub> or GND; I <sub>O</sub> = 0
I <sub>CC</sub>	quiescent supply current											
	SSI			2.0		20.0		40.0	μA	5.5	V <sub>CC</sub> or GND	I <sub>O</sub> = 0
	flip-flops			4.0		40.0		80.0		5.5		I <sub>O</sub> = 0
	MSI			8.0		80.0		160.0		5.5		I <sub>O</sub> = 0
	LSI			50.0		500		1000		5.5		I <sub>O</sub> = 0

## HCMOS family characteristics

## FAMILY SPECIFICATIONS

SYMBOL	PARAMETER	T <sub>amb</sub> (°C)							UNIT	TEST CONDITIONS		
		74HCT								V <sub>CC</sub> (V)	V <sub>I</sub>	OTHER
		+25			-40 to +85		-40 to +125					
		min.	typ.	max.	min.	max.	min.	max.				
$\Delta I_{CC}$	additional quiescent supply current per input pin for unit load coefficient is 1 (note 1)		100	360		450		490	$\mu\text{A}$	4.5 to 5.5	V <sub>CC</sub> -2.1 V	other inputs at V <sub>CC</sub> or GND; I <sub>O</sub> = 0

**Note**

1. The additional quiescent supply current per input is determined by the  $\Delta I_{CC}$  unit load, which has to be multiplied by the unit load coefficient as given in the individual data sheets. For dual supply systems the theoretical worst-case (V<sub>I</sub> = 2.4 V; V<sub>CC</sub> = 5.5 V) specification is:  $\Delta I_{CC}$  = 0.65 mA (typical) and 1.8 mA (maximum) across temperature.

## HCMOS family characteristics

## FAMILY SPECIFICATIONS

**DC CHARACTERISTICS FOR 74HCU**

Voltages are referenced to GND (ground = 0 V)

SYMBOL	PARAMETER	T <sub>amb</sub> (°C)							UNIT	TEST CONDITIONS		
		74HCU								V <sub>CC</sub> (V)	V <sub>I</sub>	OTHER
		+25			-40 to +85		-40 to +125					
		min.	typ.	max.	min.	max.	min.	max.				
V <sub>IH</sub>	HIGH level input voltage	1.7	1.4		1.7		1.7		V	2.0		
		3.6	2.6		3.6		3.6			4.5		
		4.8	3.4		4.8		4.8			6.0		
V <sub>IL</sub>	LOW level input voltage		0.6	0.3		0.3		0.3	V	2.0		
			1.9	0.9		0.9		0.9		4.5		
			2.6	1.2		1.2		1.2		6.0		
V <sub>OH</sub>	HIGH level output voltage	1.8	2.0		1.8		1.8		V	2.0	V <sub>IH</sub> or V <sub>IL</sub>	-I <sub>O</sub> = 20 μA
		4.0	4.5		4.0		4.0			4.5		-I <sub>O</sub> = 20 μA
		5.5	6.0		5.5		5.5			6.0		-I <sub>O</sub> = 20 μA
V <sub>OH</sub>	HIGH level output voltage	3.98	4.32		3.84		3.7		V	4.5	V <sub>CC</sub> or GND	-I <sub>O</sub> = 4.0 mA
		5.48	5.81		5.34		5.2			6.0		-I <sub>O</sub> = 5.2 mA
V <sub>OL</sub>	LOW level output voltage		0	0.2		0.2		0.2	V	2.0	V <sub>IH</sub> or V <sub>IL</sub>	I <sub>O</sub> = 20 μA
			0	0.5		0.5		0.5		4.5		I <sub>O</sub> = 20 μA
			0	0.5		0.5		0.5		6.0		I <sub>O</sub> = 20 μA
V <sub>OL</sub>	LOW level output voltage		0.15	0.26		0.33		0.4	V	4.5	V <sub>CC</sub> or GND	I <sub>O</sub> = 4.0 mA
			0.16	0.26		0.33		0.4		6.0		I <sub>O</sub> = 5.2 mA
±I <sub>I</sub>	input leakage current			0.1		1.0		1.0	μA	6.0	V <sub>CC</sub> or GND	
I <sub>CC</sub>	quiescent supply current SSI			2.0		20.0		40.0	μA	6.0	V <sub>CC</sub> or GND	I <sub>O</sub> = 0



## HCMOS family characteristics

## FAMILY SPECIFICATIONS

**AC CHARACTERISTICS FOR 74HC**GND = 0 V;  $t_r = t_f = 6$  ns;  $C_L = 50$  pF

SYMBOL	PARAMETER	$T_{amb}$ (°C)						UNIT	TEST CONDITIONS		
		74HC							$V_{CC}$ (V)	WAVEFORMS	
		+25			-40 to +85		-40 to +125				
		min.	typ.	max.	min.	max.	min.				max.
$t_{THL} / t_{TLH}$	output transition time standard outputs		19	75		95		110	ns	2.0 4.5 6.0	Figs 3 and 4
			7	15		19		22			
			6	13		16		19			
$t_{THL} / t_{TLH}$	output transition time bus driver outputs		14	60		75		90	ns	2.0 4.5 6.0	Figs 3 and 4
			5	12		15		18			
			4	10		13		15			

**AC CHARACTERISTICS FOR 74HCU**GND = 0 V;  $t_r = t_f = 6$  ns;  $C_L = 50$  pF

SYMBOL	PARAMETER	$T_{amb}$ (°C)						UNIT	TEST CONDITIONS		
		74HCU							$V_{CC}$ (V)	WAVEFORMS	
		+25			-40 to +85		-40 to +125				
		min.	typ.	max.	min.	max.	min.				max.
$t_{THL} / t_{TLH}$	output transition time		19	75		95		110	ns	2.0 4.5 6.0	Fig.1
			7	15		19		22			
			6	13		16		19			

**AC CHARACTERISTICS FOR 74HCT**GND = 0 V;  $t_r = t_f = 6$  ns;  $C_L = 50$  pF

SYMBOL	PARAMETER	$T_{amb}$ (°C)						UNIT	TEST CONDITIONS		
		74HCT							$V_{CC}$ (V)	WAVEFORMS	
		+25			-40 to +85		-40 to +125				
		min.	typ.	max.	min.	max.	min.				max.
$t_{THL} / t_{TLH}$	output transition time standard outputs		7	15		19		22	ns	4.5	Figs 8 and 9
$t_{THL} / t_{TLH}$	output transition time bus driver outputs		5	12		15		18	ns	4.5	Figs 8 and 9

**HCU TYPES**

**AC waveforms 74HCU**

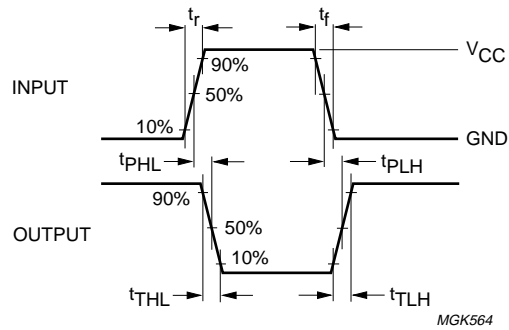
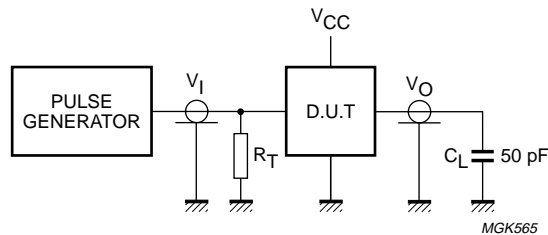

Fig.1 Input rise and fall times, transition times and propagation delays for combinatorial logic ICs.

**Test circuit for 74HCU**



- $C_L$  = load capacitance including jig and probe capacitance (see AC CHARACTERISTICS for values).
- $R_T$  = termination resistance should be equal to the output impedance  $Z_o$  of the pulse generator.

Fig.2 Test circuit.

HC TYPES

AC waveforms 74HC

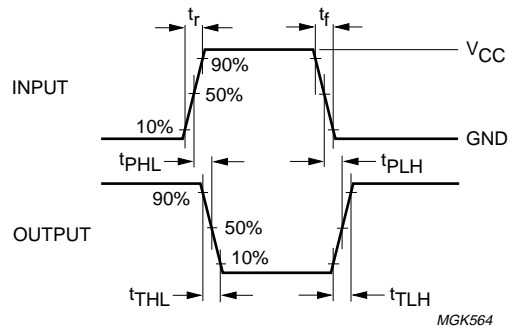
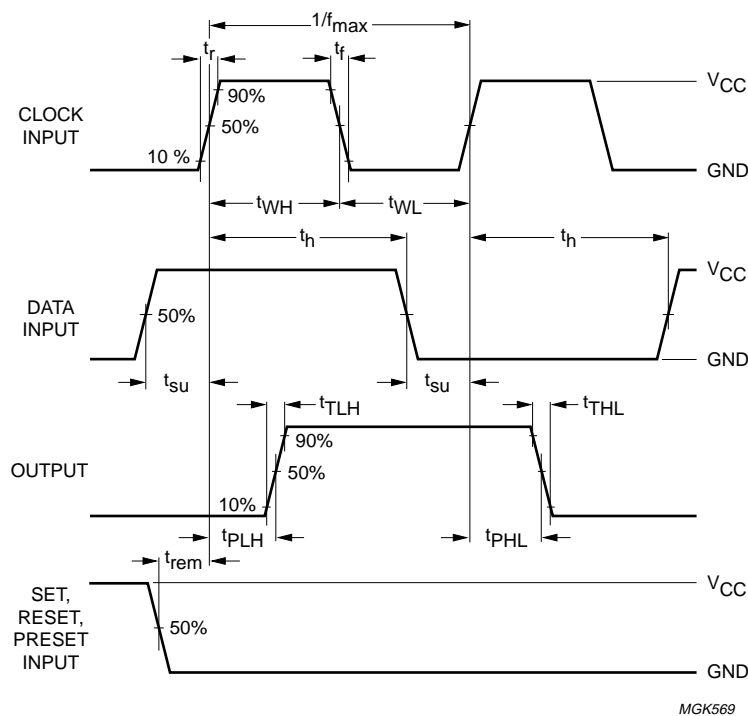

Fig.3 Input rise and fall times, transition times and propagation delays for combinatorial logic ICs.

AC waveforms 74HC



- (1) In Fig.4 the active transition of the clock is going from LOW-to-HIGH and the active level of the forcing signals (SET, RESET and PRESET) is HIGH. The actual direction of the transition of the clock input and the actual active levels of the forcing signals are specified in the individual device data sheet.
- (2) For AC measurements:  $t_r = t_f = 6$  ns; when measuring  $f_{max}$ , there is no constraint on  $t_r$ ,  $t_f$  with 50% duty factor.

Fig.4 Set-up times, hold times, removal times, propagation delays and the maximum clock pulse frequency for sequential logic ICs.

Test circuit for 74HC

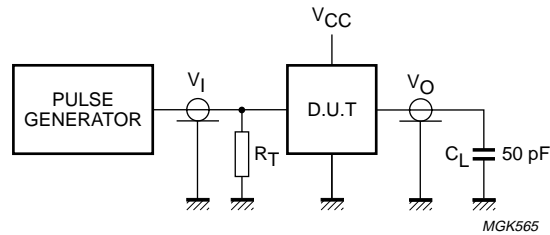

- $C_L$  = load capacitance including jig and probe capacitance (see AC CHARACTERISTICS for values).
- $R_T$  = termination resistance should be equal to the output impedance  $Z_o$  of the pulse generator.

Fig.5 Test circuit.

AC waveforms 74HC (continued)

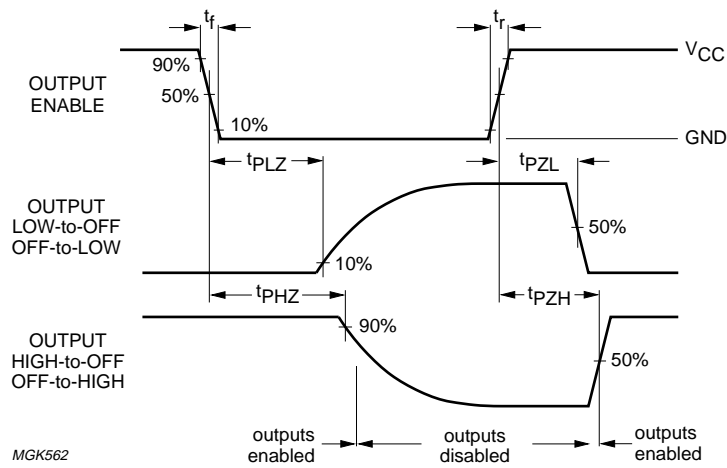
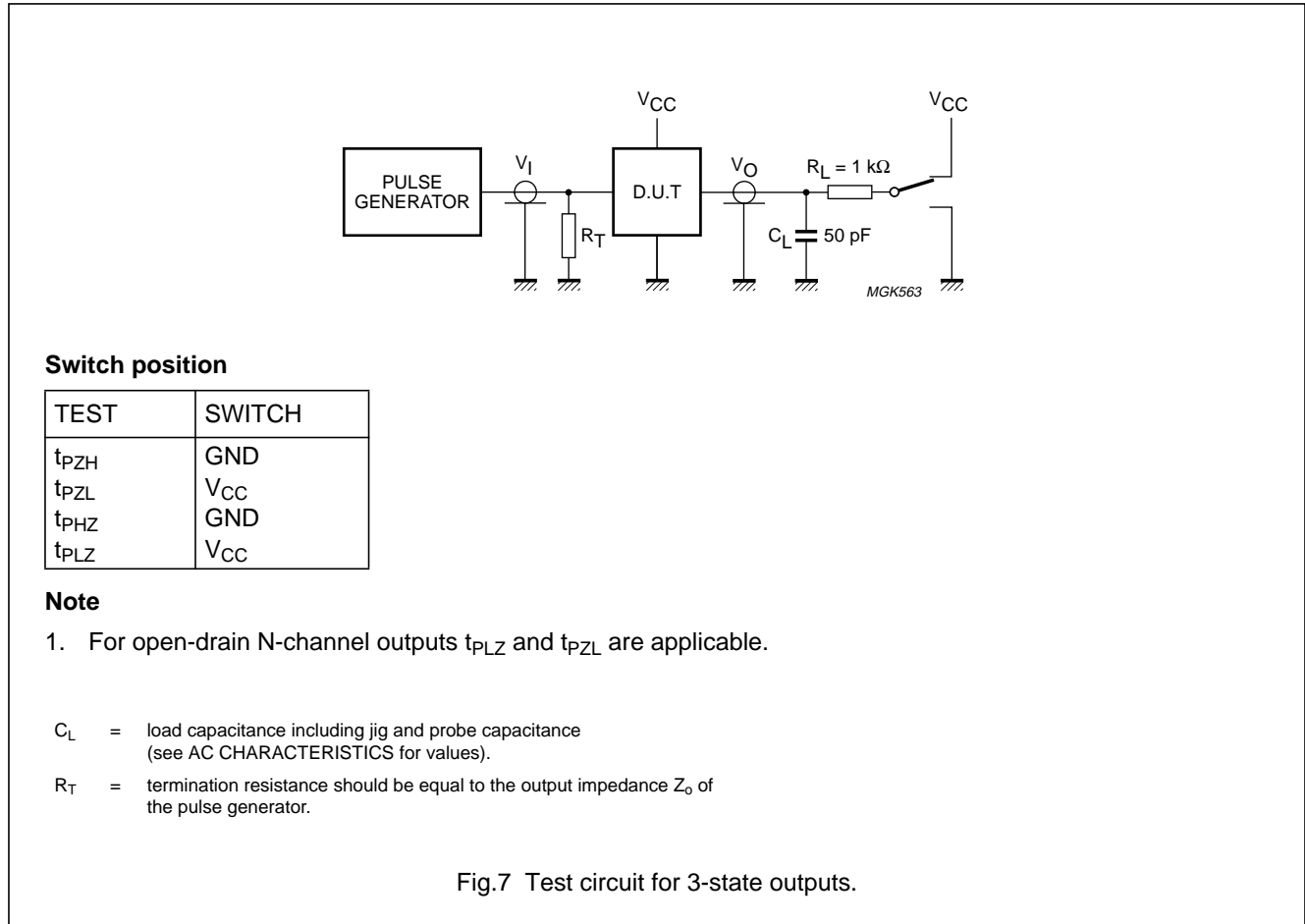

Fig.6 Propagation delays of 3-state outputs.

Test circuit for 74HC



HCT TYPES

AC waveforms 74HCT

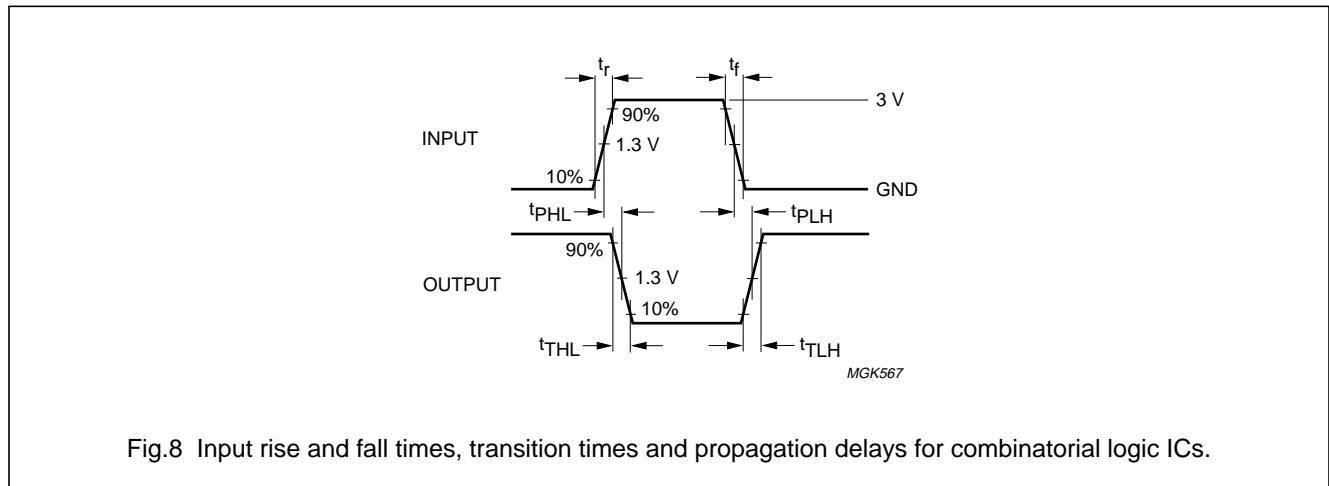

AC waveforms 74HCT

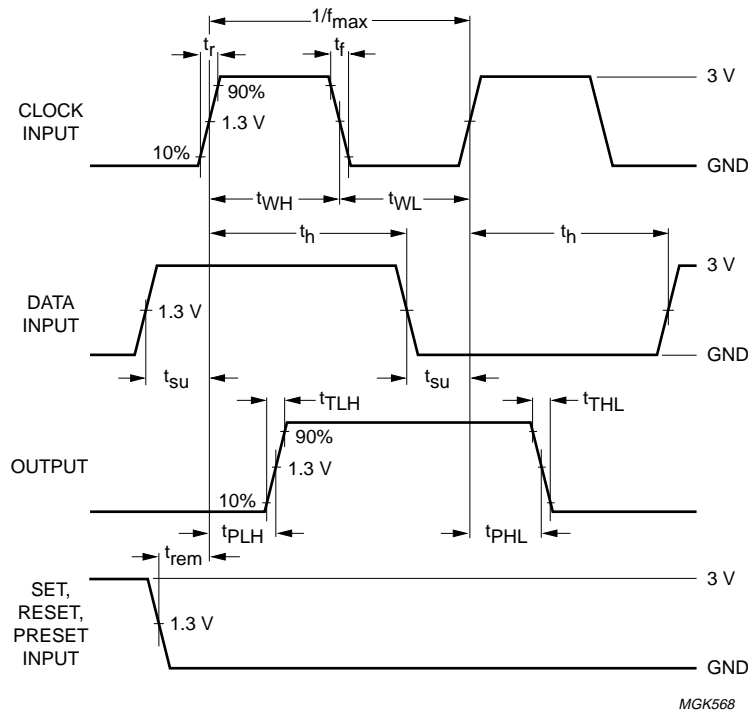

MGK568

- (1) In Fig.9 the active transition of the clock is going from LOW-to-HIGH and the active level of the forcing signals (SET, RESET and PRESET) is HIGH. The actual direction of the transition of the clock input and the actual active levels of the forcing signals are specified in the individual device data sheet.
- (2) For AC measurements:  $t_r = t_f = 6$  ns; when measuring  $f_{max}$ , there is no constraint on  $t_r, t_f$  with 50% duty factor.

Fig.9 Set-up times, hold times, removal times, propagation delays and the maximum clock pulse frequency for sequential logic ICs.

Test circuit for 74HCT

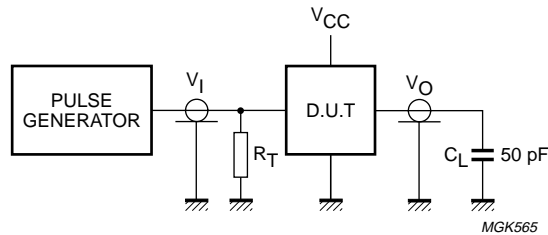

MGK565

- $C_L$  = load capacitance including jig and probe capacitance (see AC CHARACTERISTICS for values).
- $R_T$  = termination resistance should be equal to the output impedance  $Z_o$  of the pulse generator.

Fig.10 Test circuit.

AC waveforms 74HCT (continued)

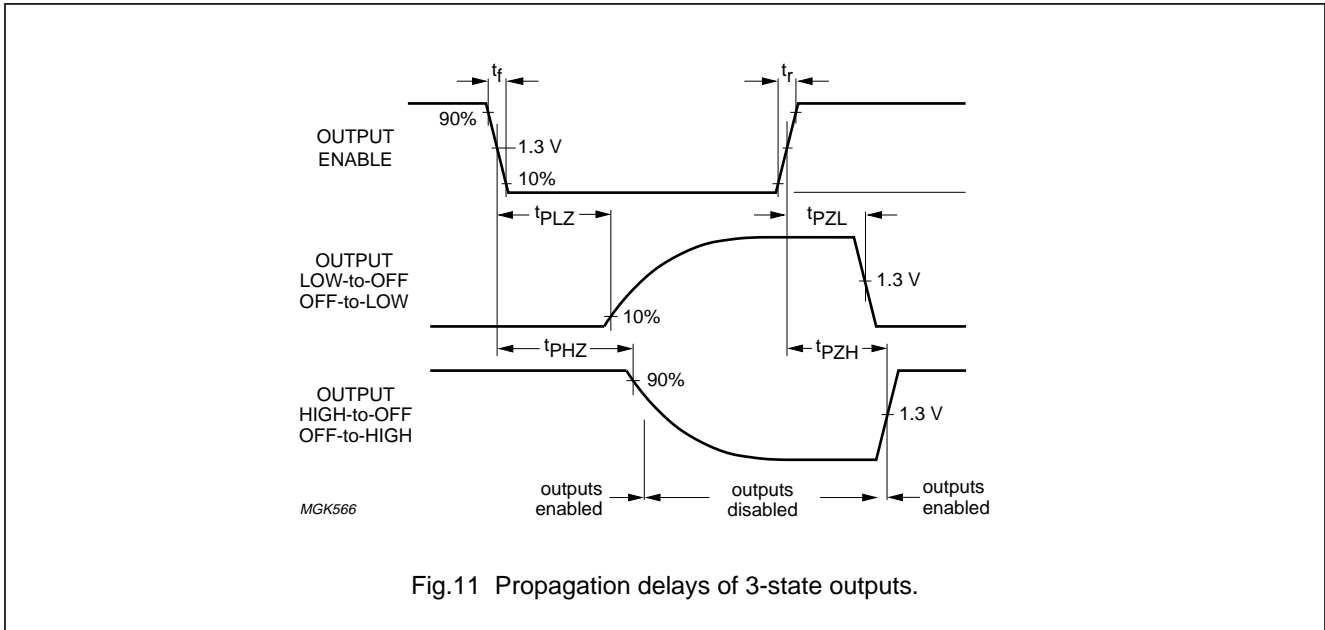

Test circuit for 74HCT

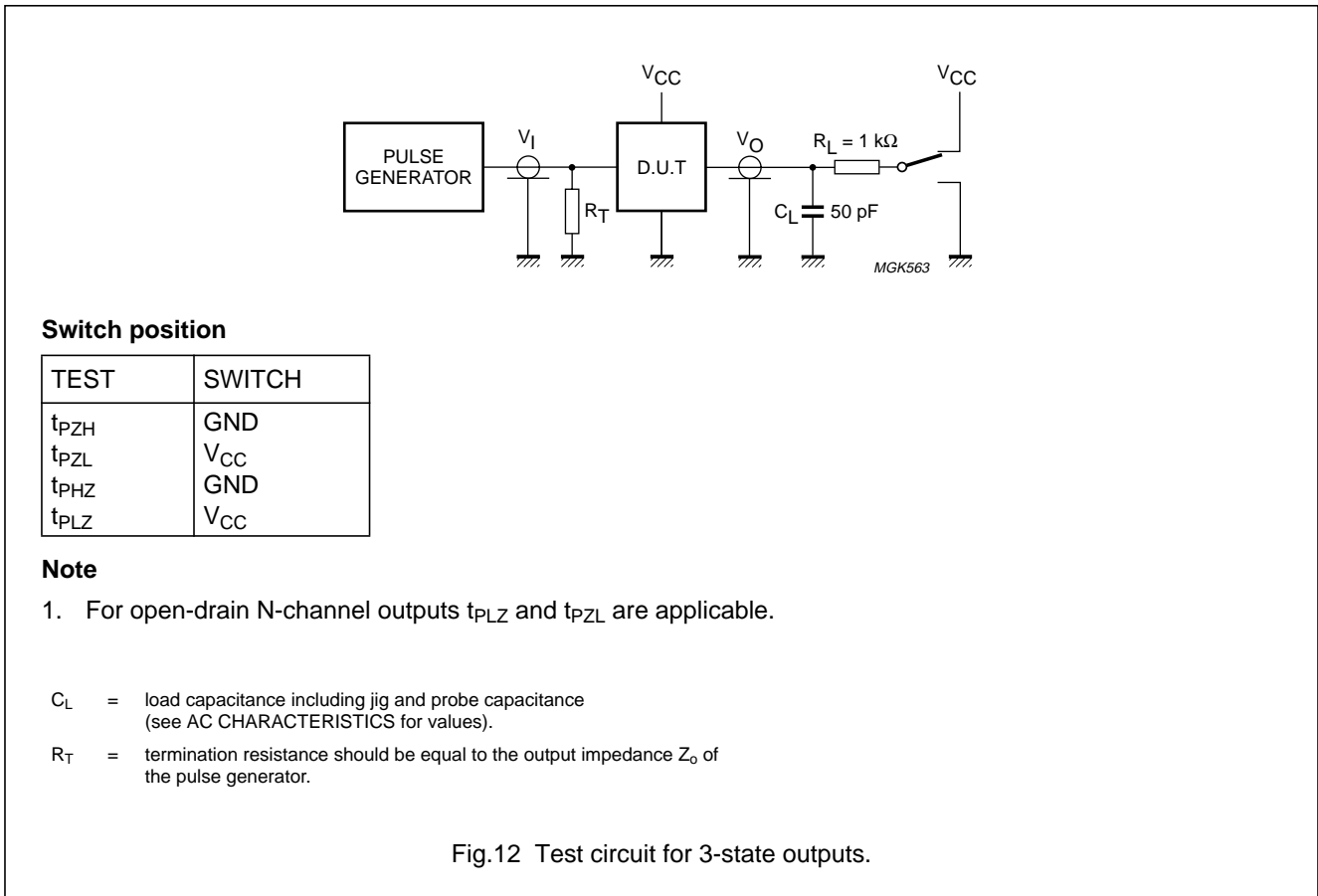

## HCMOS family characteristics

## FAMILY SPECIFICATIONS

### DATA SHEET SPECIFICATION GUIDE

#### INTRODUCTION

The 74HCMOS data sheets have been designed for ease-of-use. A minimum of cross-referencing for more information is needed.

#### TYPICAL PROPAGATION DELAY AND FREQUENCY

The typical propagation delays listed at the top of the data sheets are the average of  $t_{PLH}$  and  $t_{PHL}$  for the longest data path through the device with a 15 pF load.

For clocked devices, the maximum frequency of operation is also given. The typical operating frequency is the maximum device operating frequency with a 50% duty factor and no constraints on  $t_r$  and  $t_f$ .

#### LOGIC SYMBOLS

Two logic symbols are given for each device - the conventional one (Logic Symbol) which explicitly shows the internal logic (except for complex logic) and the IEC Logic Symbol as developed by the IEC (International Electrotechnical Commission).

The IEC has been developing a very powerful symbolic language that can show the relationship of each input of a digital logic current to each output without explicitly showing the internal logic.

Internationally, Working Group 2 of IEC Technical Committee TC-3 has prepared a new document (Publication 617-12) which supersedes Publication 117-15, published in 1972.

#### RATINGS

The "RATINGS" table (Limiting values in accordance with the Absolute Maximum System - IEC134) lists the maximum limits to which the device can be subjected without damage. This doesn't imply that the device will function at these extreme conditions, only that, when these conditions are removed and the device operated within the Recommended Operating Conditions, it will still be functional and its useful life won't have been shortened.

The maximum rated supply voltage of 7 V is well below the typical breakdown voltage of 18 V.

#### RECOMMENDED OPERATING CONDITIONS

The "RECOMMENDED OPERATING CONDITIONS" table lists the operating ambient temperature and the

conditions under which the limits in the "DC CHARACTERISTICS" and "AC CHARACTERISTICS" tables will be met. The table should not be seen as a set of limits guaranteed by the manufacturer, but as the conditions used to test the devices and guarantee that they will then meet the limits in the DC and AC CHARACTERISTICS tables.

#### DC CHARACTERISTICS

The "DC CHARACTERISTICS" table reflects the DC limits used during testing. The values published are guaranteed.

The threshold values of  $V_{IH}$  and  $V_{IL}$  can be tested by the user. If  $V_{IH}$  and  $V_{IL}$  are applied to the inputs, the output voltages will be those published in the "DC CHARACTERISTICS" table. There is a tendency, by some, to use the published  $V_{IH}$  and  $V_{IL}$  thresholds to test a device for functionality in a "function-table exercizer" mode. This frequently causes problems because of the noise present at the test head of automated test equipment with cables up to 1 metre. Parametric tests, such as those used for the output levels under the  $V_{IH}$  and  $V_{IL}$  conditions are done fairly slowly, in the order of milliseconds, so that there is no noise at the inputs when the outputs are measured. But in functionality testing, the outputs are measured much faster, so there can be noise on the inputs, before the device has assumed its final and correct output state. Thus, never use  $V_{IH}$  and  $V_{IL}$  to test the functionality of any HCMOS device type; instead, use input voltages of  $V_{CC}$  (for the HIGH state) and 0 V (for the LOW state). In no way does this imply that the devices are noise-sensitive in the final system.

In the data sheets, it may appear strange that the typical  $V_{IL}$  is higher than the maximum  $V_{IL}$ . However, this is because  $V_{ILmax}$  is the maximum  $V_{IL}$  (guaranteed) for all devices that will be recognized as a logic LOW. However, typically a **higher**  $V_{IL}$  will also be recognized as a logic LOW. Conversely, the typical  $V_{IH}$  is lower than its minimum guaranteed level.

For 74HCMOS, unlike TTL, no output HIGH short-circuit current is specified. The use of this current, for example, to calculate propagation delays with capacitive loads, is covered by the HCMOS graphs showing the output drive capability and those showing the dependence of propagation delay on load capacitance.

The quiescent supply current  $I_{CC}$  is the leakage current of all the reversed-biased diodes and the OFF-state MOS transistors. It is measured with the inputs at  $V_{CC}$  or GND and is typically a few nA.



---

## HCMOS family characteristics

## FAMILY SPECIFICATIONS

---

### AC CHARACTERISTICS

The "AC CHARACTERISTICS" table lists the guaranteed limits when a device is tested under the conditions given in the AC Test Circuits and Waveforms section.

### TEST CIRCUITS

Good high-frequency wiring practices should be used in test circuits. Capacitor leads should be as short as possible to minimize ripples on the output waveform transitions and undershoot. Generous ground metal (preferably a ground-plane) should be used for the same reasons. A  $V_{CC}$  decoupling capacitor should be provided at the test socket, also with short leads. Input signals should have rise and fall times of 6 ns, a signal swing of 0 V to  $V_{CC}$  for 74HC and 0 V to 3 V for 74HCT; a 1.0 MHz square wave is recommended for most propagation delay tests. The repetition rate must be increased for testing  $f_{max}$ . Two pulse generators are usually required for testing such parameters as set-up time, hold time and removal time.  $f_{max}$  is also tested with 6 ns input rise and fall times, with a 50% duty factor, but for typical  $f_{max}$  as high as 60 MHz, there are no constraints on rise and fall times.

## HCMOS family characteristics

## FAMILY SPECIFICATIONS

## DEFINITIONS OF SYMBOLS AND TERMS USED IN HCMOS DATA SHEETS

## Currents

Positive current is defined as conventional current flow into a device.

Negative current is defined as conventional current flow out of a device.

$I_{CC}$	Quiescent power supply current; the current flowing into the $V_{CC}$ supply terminal.
$\Delta I_{CC}$	Additional quiescent supply current per input pin at a specified input voltage and $V_{CC}$ .
$I_{GND}$	Quiescent power supply current; the current flowing into the GND terminal.
$I_I$	Input leakage current; the current flowing into a device at a specified input voltage and $V_{CC}$ .
$I_{IK}$	Input diode current; the current flowing into a device at a specified input voltage.
$I_O$	Output source or sink current: the current flowing into a device at a specified output voltage.
$I_{OK}$	Output diode current; the current flowing into a device at a specified output voltage.
$I_{OZ}$	OFF-state output current; the leakage current flowing into the output of a 3-state device in the OFF-state, when the output is connected to $V_{CC}$ or GND.
$I_S$	Analog switch leakage current; the current flowing into an analog switch at a specified voltage across the switch and $V_{CC}$ .

## Voltages

All voltages are referenced to GND (ground), which is typically 0 V.

GND	Supply voltage; for a device with a single negative power supply, the most negative power supply, used as the reference level for other voltages; typically ground.
$V_{CC}$	Supply voltage; the most positive potential on the device.
$V_{EE}$	Supply voltage; one of two (GND and $V_{EE}$ ) negative power supplies.
$V_H$	Hysteresis voltage; difference between the trigger levels, when applying a positive and a negative-going input signal.
$V_{IH}$	HIGH level input voltage; the range of input voltages that represents a logic HIGH level in the system.

$V_{IL}$	LOW level input voltage; the range of input voltages that represents a logic LOW level in the system.
$V_{OH}$	HIGH level output voltage; the range of voltages at an output terminal with a specified output loading and supply voltage. Device inputs are conditioned to establish a HIGH level at the output.
$V_{OL}$	LOW level output voltage; the range of voltages at an output terminal with a specified output loading and supply voltage. Device inputs are conditioned to establish a LOW level at the output.
$V_{T+}$	Trigger threshold voltage; positive-going signal.
$V_{T-}$	Trigger threshold voltage; negative-going signal.

## Analog terms

$R_{ON}$	ON-resistance; the effective ON-state resistance of an analog switch, at a specified voltage across the switch and output load.
$\Delta R_{ON}$	$\Delta$ ON-resistance; the difference in ON-resistance between any two switches of an analog device at a specified voltage across the switch and output load.

## Capacitances

$C_I$	Input capacitance; the capacitance measured at a terminal connected to an input of a device.
$C_{I/O}$	Input/Output capacitance; the capacitance measured at a terminal connected to an I/O-pin (e.g. a transceiver).
$C_L$	Output load capacitance; the capacitance connected to an output terminal including jig and probe capacitance.
$C_{PD}$	Power dissipation capacitance; the capacitance used to determine the dynamic power dissipation per logic function, when no extra load is provided to the device.
$C_S$	Switch capacitance; the capacitance of a terminal to a switch of an analog device.

## HCMOS family characteristics

## FAMILY SPECIFICATIONS

## AC switching parameters

$f_i$	Input frequency; for combinatorial logic devices the maximum number of inputs and outputs switching in accordance with the device function table. For sequential logic devices the clock frequency using alternate HIGH and LOW for data input or using the toggle mode, whichever is applicable.	$t_{PLZ}$	3-state output disable time; the time between the specified reference points, normally the 50% points for the 74HC devices and the 1.3 V points for the 74HCT devices on the output enable input voltage waveform and a point representing 10% of the output swing on the output voltage waveform of a 3-state device, with the output changing from a LOW level ( $V_{OL}$ ) to a high impedance OFF-state (Z).
$f_o$	Output frequency; each output.	$t_{PZH}$	3-state output enable time; the time between the specified reference points, normally the 50% points for the 74HC devices and 1.3 V points for the 74HCT devices on the output enable input voltage waveform and the 50% point on the output voltage waveform of a 3-state device, with the output changing from a high impedance OFF-state (Z) to a HIGH level ( $V_{OH}$ ).
$f_{max}$	Maximum clock frequency; clock input waveforms should have a 50% duty factor and be such as to cause the outputs to be switching from 10% $V_{CC}$ to 90% $V_{CC}$ in accordance with the device function table.	$t_{PZL}$	3-state output enable time; the time between the specified reference points, normally the 50% points for the 74HC devices and the 1.3 V points for the 74HCT devices on the output enable input voltage waveform and the 50% point on the output voltage waveform of a 3-state device, with the output changing from a high impedance OFF-state (Z) to a LOW level ( $V_{OL}$ ).
$t_h$	Hold time; the interval immediately following the active transition of the timing pulse (usually the clock pulse) or following the transition of the control input to its latching level, during which interval the data to be recognized must be maintained at the input to ensure their continued recognition. A negative hold time indicates that the correct logic level may be released prior to the timing pulse and still be recognized.	$t_{rem}$	Removal time; the time between the end of an overriding asynchronous input, typically a clear or reset input, and the earliest permissible beginning of a synchronous control input, typically a clock input, normally measured at the 50% points for 74HC devices and the 1.3 V points for the 74HCT devices on both input voltage waveforms.
$t_r$ , $t_f$	Clock input rise and fall times; 10% and 90% values.	$t_{su}$	Set-up time; the interval immediately preceding the active transition of the timing pulse (usually the clock pulse) or preceding the transition of the control input to its latching level, during which interval the data to be recognized must be maintained at the input to ensure their recognition. A negative set-up time indicates that the correct logic level may be initiated sometime after the active transition of the timing pulse and still be recognized.
$t_{PHL}$	Propagation delay; the time between the specified reference points, normally the 50% points for 74HC and 74HCU devices on the input and output waveforms and the 1.3 V points for the 74HCT devices, with the output changing from the defined HIGH level to the defined LOW level.		
$t_{PLH}$	Propagation delay; the time between the specified reference points, normally the 50% points for 74HC and 74HCU devices on the input and output waveforms and the 1.3 V point for the 74HCT devices, with the output changing from the defined LOW level to the defined HIGH level.		
$t_{PHZ}$	3-state output disable time; the time between the specified reference points, normally the 50% points for the 74HC and 74HCU devices and the 1.3 V points for the 74HCT devices on the output enable input voltage waveform and a point representing 10% of the output swing on the output voltage waveform of a 3-state device, with the output changing from a HIGH level ( $V_{OH}$ ) to a high impedance OFF-state (Z).		

## HCMOS family characteristics

## FAMILY SPECIFICATIONS

---

- $t_{THL}$  Output transition time; the time between two specified reference points on a waveform, normally 90% and 10% points, that is changing from HIGH-to-LOW.
- $t_{TLH}$  Output transition time; the time between two specified reference points on a waveform, normally 10% and 90% points, that is changing from LOW-to-HIGH.
- $t_W$  Pulse width; the time between the 50% amplitude points on the leading and trailing edges of a pulse for 74HC and 74HCU devices and at the 1.3 V points for 74HCT devices.

## X-ON Electronics

Largest Supplier of Electrical and Electronic Components

*Click to view similar products for [nxp manufacturer](#):*

Other Similar products are found below :

[MC13211R2](#) [PCA9518PW,112](#) [LFSTBEB865X](#) [MC33399PEFR2](#) [PCA9551PW,112](#) [MC34825EPR2](#) [PCF8583P](#) [MC68340AB16E](#)  
[MC8640DTVJ1250HE](#) [EVBCRTOUCH](#) [MC9S08PT16AVLC](#) [MC9S08PT8AVTG](#) [MC9S08SH32CTL](#) [MCF54415CMJ250](#) [MCIMX6Q-SDB](#)  
[MCIMX6SX-SDB](#) [74ALVC125BQ,115](#) [74HC4050N](#) [74HC4514N](#) [MK21FN1M0AVLQ12](#) [MKV30F128VFM10](#) [FRDM-K66F](#) [FRDM-](#)  
[KW40Z](#) [FRDM-MC-LVBLDC](#) [PESD18VF1BSFYL](#) [PMF63UNEX](#) [PSMN4R0-60YS,115](#) [HEF4028BPN](#) [RAPPID-567XFSW](#)  
[MPC565MVR56](#) [MPC574XG-176DS](#) [MPC860PCVR66D4](#) [BT137-600E](#) [BT139X-600.127](#) [BUK7628-100A118](#) [BUK765R0-100E.118](#)  
[BZT52H-B9V1.115](#) [BZV85-C3V9.113](#) [BZX79-C47.113](#) [P5020NSE7VNB](#) [S12ZVML12EVBLIN](#) [SCC2692AC1N40](#) [LPC1785FBD208K](#)  
[LPC2124FBD64/01](#) [LS1020ASN7KQB](#) [LS1020AXN7HNB](#) [LS1020AXN7KQB](#) [LS1043ASE7PQA](#) [T1023RDB-PC](#) [FRDM-KW24D512](#)