

AN10713

18 W CFL lamp design using UBA2024 application development tool and application examples

Rev. 4 — 11 February 2011

Application note

Document information

Info	Content
Keywords	UBA2024, CFL, CCFL, integrated half-bridge driver and integrated switches, lighting
Abstract	Application note for the NXP UBA2024 and UBA2024A CFL driver



Revision history

Rev	Date	Description
04	20110211	fourth issue
03	20100406	third issue
02	20091010	second issue
01	20090722	first issue

Contact information

For more information, please visit: <http://www.nxp.com>

For sales office addresses, please send an email to: salesaddresses@nxp.com

1. Introduction

WARNING

Lethal voltage and fire ignition hazard



The non-insulated high voltages that are present when operating this product, constitute a risk of electric shock, personal injury, death and/or ignition of fire.

This product is intended for evaluation purposes only. It shall be operated in a designated test area by personnel qualified according to local requirements and labor laws to work with non-insulated mains voltages and high-voltage circuits. This product shall never be operated unattended.

The UBA2024 is an integrated half-bridge power IC, designed for use in an integrated/sealed Compact Fluorescent Lamps (CFL) at lamp output powers up to 22 W. Typical input voltages are from 100 V (AC) to 127 V (AC) and from 220 V (AC) to 240 V (AC). This application note describes typical integrated CFL applications in the 3 W to 18 W range, depending on lamp and input voltage. The term lamp is used when the burner and electronic ballast are meant.

The UBA2024 includes half-bridge power transistors with a level-shifter and drivers, bootstrap circuitry, an internal power supply, a precision oscillator and a start-up frequency sweep function for soft start and/or quasi-preheating. There are two versions of the UBA2024, the UBA2024, specified for (total) lamp powers of up to 15 W and the UBA2024A is intended for lamp powers that are above 15 W. The maximum lamp power depends on the lamp design and the dissipation of the IC. In this application note a non-dimmable 18 W application is described.

The UBA2024/UBA2024A is available as a DIP8 package (extension letter P after type code) and an SO14 package (extension letter T after type code). This document mainly describes the DIP package, but the same can be applied to the UBA2024 in SO14 package.

Due to the high level of integration, only a few external components are needed in a lamp ballast with the UBA2024.

1.1 Features

- Integrated half-bridge power IC for CFL applications (both power and controller)
- Accurate oscillator with adjustable frequency
- Soft-start by frequency sweep down from start frequency
- Quasi-preheat option (programmable sweep down timing)

1.2 System benefits

- Allows very compact integrated lamp ballasts which fit a small shell
- Low cost CFL applications due to low component count
- Higher reliability due to low component count
- Longer lamp life due to quasi-preheat
- Easy to apply
- Based on EZ-HV Silicon On Insulator (SOI) technology

- Can withstand a maximum voltage of 550 V

2. Circuit diagram

Figure 1 shows the typical circuit diagram of the UBA2024. Figure 2 shows a version with a voltage doubler for use in 120 V (AC) applications. The voltage doubler is needed for medium and high powers in regions that have lower mains voltages.

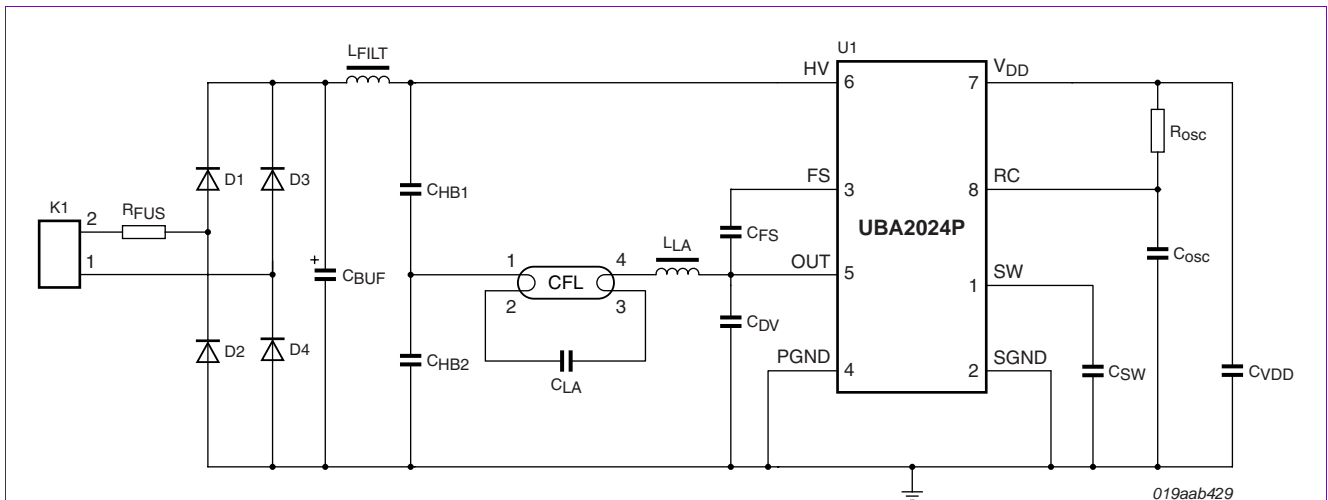

Fig 1. Typical application diagram

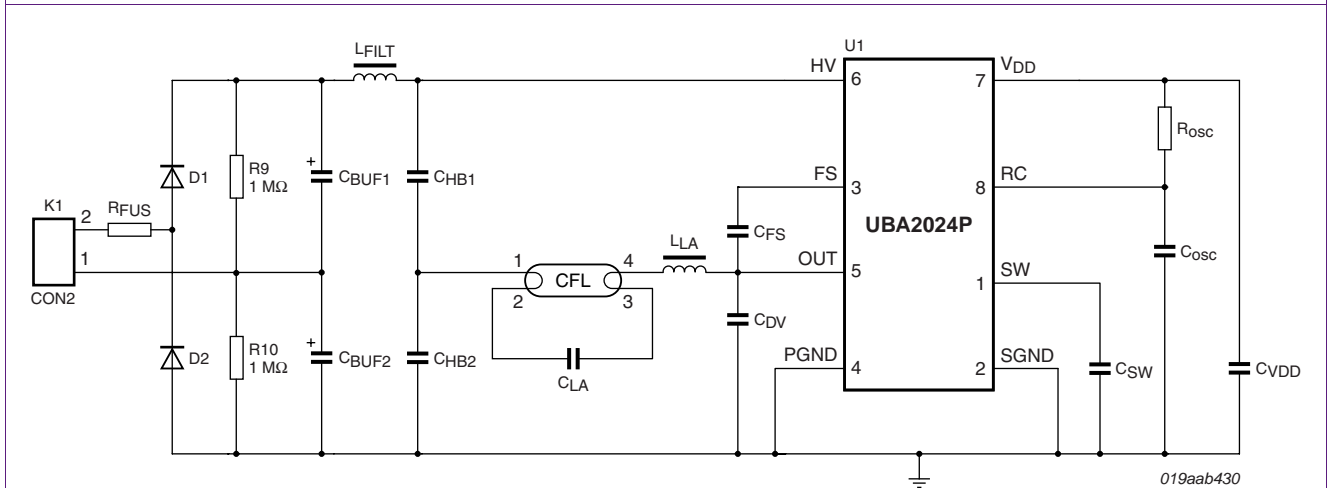

Fig 2. Typical application diagram with voltage doubler

See the *UBA2024 data sheet* for a functional description.

3. Design of an 18 W non-dimmable CFL

An application development tool is available to simplify the lamp design and calculation of the resonance circuit. This section explains the selection criteria for the component values. It also clarifies how to feed the application development tool with the appropriate values for components. With the tool and with the help of some practical guidelines it should be easy to set-up designs for different lamp powers. Throughout this document the light source itself is called the burner.

3.1 Selecting input configuration, buffer capacitor and fused resistor

Table 1 shows the values for the input section of the standard 230 V (AC) version and the 120 V (AC) version with and without a voltage doubler.

Table 1. Advised input configuration

Input voltage	Driver IC	Lamp power ^[1]	Input configuration	C _{BUF1}	C _{BUF1} , C _{BUF2}	fused resistor ^[2]
100 V (AC) to 127 V (AC)	UBA2024P	4 W	Standard	10 μF/200 V	n.a.	18 Ω/(0.25 W/23 W)
	UBA2024T	5 W to 6 W		15 μF/200 V	n.a.	12 Ω/(0.5 W/35 W)
		7 W to 8 W	Voltage doubler	n.a.	10 μF/200 V	10 Ω/(0.5 W/47 W)
		9 W to 11 W		n.a.	15 μF/200 V	8.2 Ω/(0.75 W/70 W)
		12 W to 14 W		n.a.	22 μF/200 V	6.8 Ω/(1 W/103 W)
		15 W to 18 W		n.a.	22 μF/200 V	6.8 Ω/(1 W/103 W)
	UBA2024AP UBA2024AT					
220 V (AC) to 240 V (AC)	UBA2024P	5 W	Standard	2.2 μF/400 V	n.a.	47 Ω/(0.25 W/23 W)
	UBA2024T	6 W to 8 W		3.3 μF/400 V	n.a.	39 Ω/(0.25 W/23 W)
		9 W to 11 W	Voltage doubler	4.7 μF/400 V	n.a.	33 Ω/(0.5 W/32 W)
		12 W to 15 W		6.8 μF/400 V	n.a.	27 Ω/(0.5 W/47 W)
		15 W to 18 W		6.8 μF/400 V	n.a.	15 Ω/(1 W/103 W)
		UBA2024AP UBA2024AT				

[1] Overall lamp power including driver circuit

[2] Minimum continuous power rating/minimum peak power rating (20 ms).

3.2 Choosing frequency, lamp inductor and capacitor

3.2.1 Input values

The application development tool calculates the component values based on the following input parameters:

- Selection of the driver IC type (UBA2024A type for lamp power > 15 W)
- Burner power
- Burner ignition voltage
- Burner operating voltage
- Mains input voltage and frequency (typical operating voltage)
- Combined value of the DC blocking capacitors

[Figure 3](#) shows the part of the application development tool where the base values can be entered. The example shows the design of an 18 W lamp. This is the total lamp power which means 16.8 W burner power and approximately a 1.5 W loss in the electronic ballast. The burner used in this example is a replaceable burner. It is based on a G24q-2 fitting with the following parameters.

- Burner power = 16.8 W
- Burner voltage = 80 V
- Ignition voltage = 600 V

The following actions need to be taken:

1. Enter the burner parameters
2. Select the mains voltage to be used for the 18 W lamp (230 V (AC))
3. Select the IC (in this case the UBA2024AP, 8-pin DIL version)

The UBA2024P cannot be used because the R_{DSon} of its switches is too high.

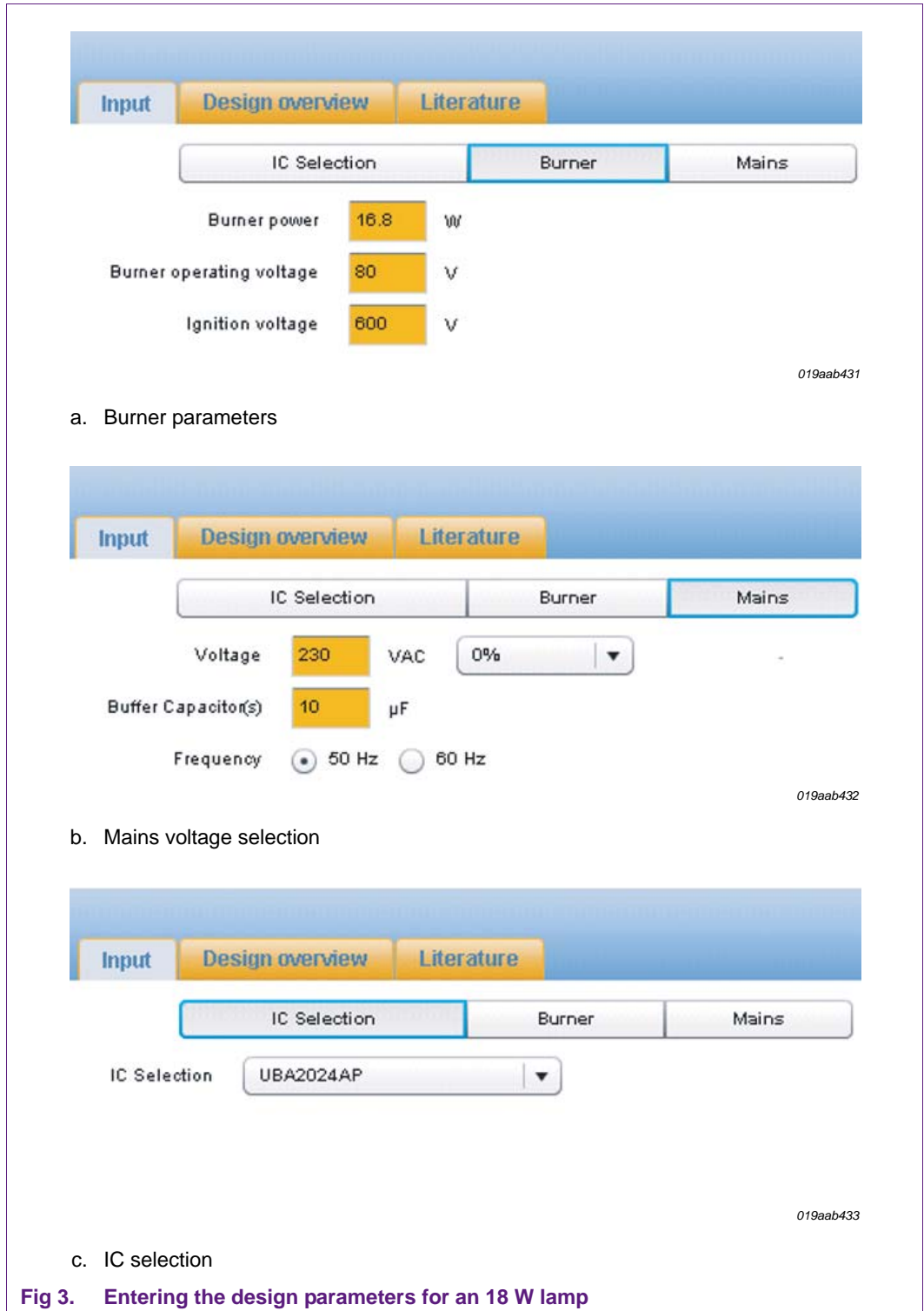
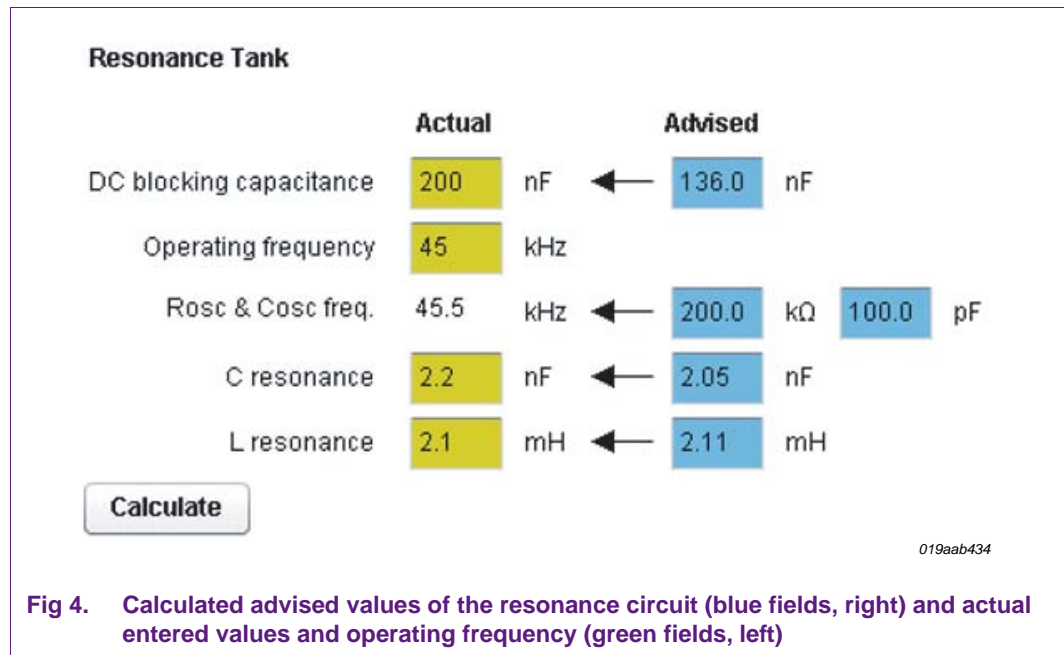

Fig 3. Entering the design parameters for an 18 W lamp

Using the lamp power given in [Figure 3](#), the minimum value of the parallel DC blocking capacitors, CHB1 and CHB2 as a combined value, is advised in [Figure 4](#). Using 16.8 W burner power, the advised minimum value is 2×68 nF, but 2×100 nF was chosen instead.

Based on the burner parameters mains voltage and frequency, the buffer capacitor listed in [Table 1](#), and selected DC blocking capacitors, a first calculation of the LC resonance tank can be executed by pressing the Calculate button. The application development tool then calculates advisory values for the resonance inductor and capacitor. The default oscillator frequency is set to 42 kHz. After the Calculate button has been pressed for the first time, the actual values in [Figure 4](#) have to be matched with the values in the advised fields on the right.

This is done in the left column (Actual) by entering values for the resonance capacitor and inductor shown in [Figure 4](#). In this design the frequency is adjusted a little higher (45 kHz) to obtain an inductance of 2.1 mH and a capacitance value of 2.2 nF.



When choosing the values for the L resonance (L_{LA}) and C resonance (C_{LA}) it is recommended to match the overall lamp power of the entered L and C resonance values with the calculated lamp power of the recommended resonance values. See [Figure 5](#) (middle column).

Round off the C resonance to the nearest higher value available in the E range and later check in the lamp prototype if the chosen L and C resonances give a clean lamp turn-on as shown in [Figure 12](#). If in the prototype the lamp turns on before ignition (the lamp current is flowing before ignition of the lamp and the voltage has dropped to a lower level), increase the value of C resonance to lower the ignition frequency (f_{ign}) and the lamp voltage during the quasi-preheat period. Ideally, f_{ign} should be close to 1.7 times the operating frequency, f_{out} (see [Section 3.4](#)). Alternatively, a larger C_{SW} capacitor providing a longer quasi-preheat time can be a solution.

L resonance is, in most cases, a custom design and not a standard component allowing its value to be made to match closely with the advised value. Since the L mainly determines the lamp current and therefore the lamp power, it is best practice to round off L resonance to a higher value rather than to a lower value than advised. This can

compensate for a higher line voltage tolerance on the oscillator frequency to preserve lamp life. The effect of line voltage tolerance can be added in the calculation by selecting a different percentage behind the mains voltage in [Figure 3](#).

[Figure 5](#) shows the range of power in the lamp for the specified conditions. The values **do not** indicate the minimum and maximum rectified AC mains voltage but the minimum and maximum voltages measured with an oscilloscope on pin V_{HV} under load conditions (see [Figure 12](#), channel 2). The values in [Figure 5](#) are based on the entered values shown in [Figure 3](#) and [Figure 4](#).

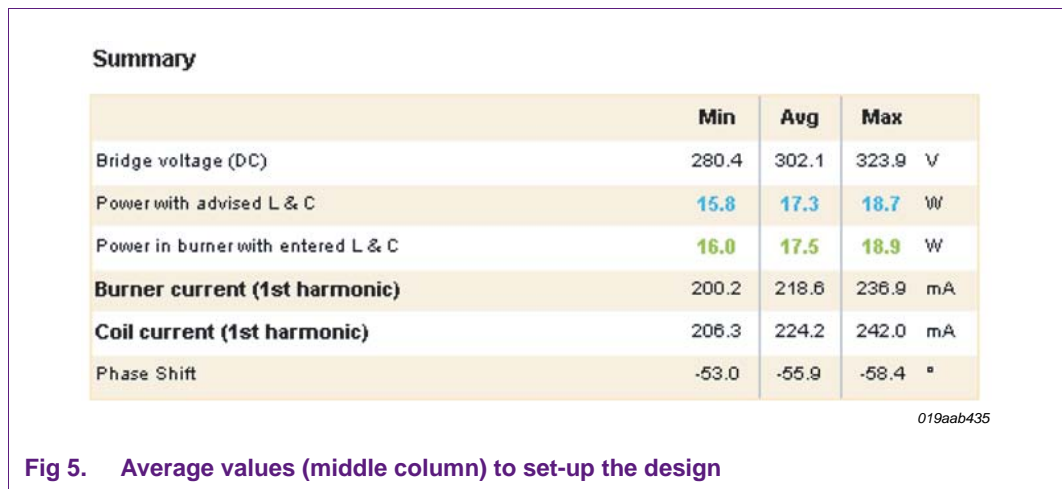

3.2.2 Calculation plots

[Figure 6](#), [Figure 7](#) and [Figure 8](#) are based on the values entered in [Figure 3](#) and [Figure 4](#). [Figure 6](#) shows the most important graph. This graph shows the lamp power based on the advised calculation (blue) and the lamp power based on the actual values (green) as function of the DC bridge voltage. If the values for L_{LA} and C_{LA} are correct the two lines should coincide.

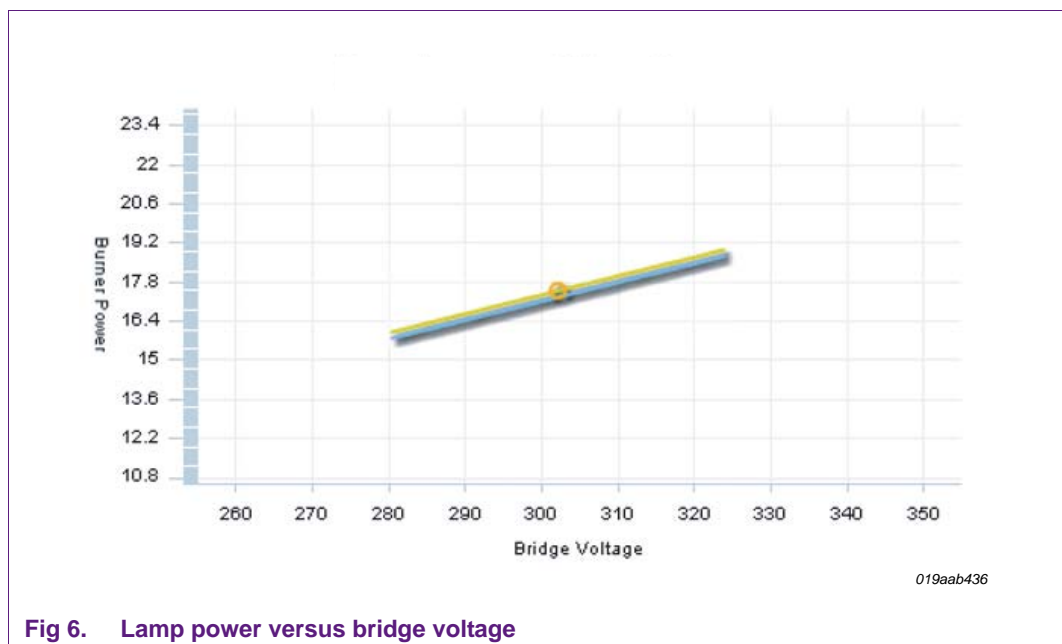

[Figure 7](#) shows the voltage to current phase shift between the voltage on and the current through the OUT pin of the IC caused by the L and C resonances, C_{DV} and the lamp.

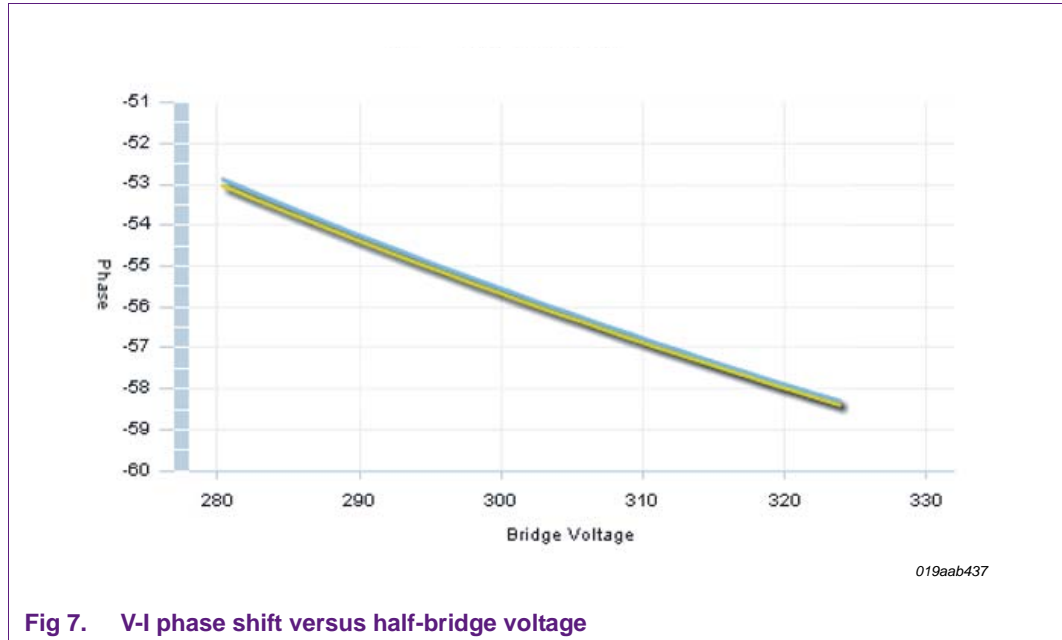

Fig 7. V-I phase shift versus half-bridge voltage

To guarantee safe operation, care must be taken that the phase shift between the output voltage and the output current is large enough to avoid capacitive mode. To be safe a phase shift lower than -20° is advised.

The preferred safe operating range is a phase shift between -40° and -60° . Lower phase shifts, lower than -60° , will cause extra losses in the power FETs as the reactive current does add to the losses in the UBA2024.

[Figure 8](#) shows the continuous current through the UBA2024 FETs during normal operation. The RMS current should not exceed 270 mA for the UBA2024A.



Fig 8. FET currents as function of bridge voltage

Figure 9 also shows the calculated ignition frequency. The ignition frequency depends on the burner and on the resonance circuit (L_{LA} , C_{LA} , DC-blocking capacitor and the voltage on V_{bridge}). The ideal ignition frequency for the UBA2024 is at 1.7 times the operating frequency.

Care must be taken that the ignition frequency is not lower than 1.6 times the operating frequency and not higher than 2.2 times the operating frequency. As the frequency sweep starts at 2.5 times the operating frequency, an ignition frequency that is too high will not give enough time for the quasi-preheat of the burner filaments. A warning is given in the application development tool if the resonance frequency is outside this range.

The application development tool has various built-in checks. It generates a warning or an error message in the status field when the chosen design values go beyond specification limits of the IC. The status information on the design becomes available when pressing the Status button.

When no suitable values for L or C resonances can be found, the operating frequency can be adjusted, so that a new set of values for L and C resonances can be calculated. Real values of available components should be entered in the “Application actual values” section. This can be repeated until a satisfactory solution has been found. See Section 3.3 for more information on the operating frequency.

3.2.3 Coil

In the section “Coil designs parameters” (example in Figure 9), the most important requirements for the inductor are shown. These together with the inductance entered in Figure 4 and the operating temperature of the inductor should be enough information to design a coil. Due to losses in the inductor, the operating temperature of the inductor is higher than the lamp ambient temperature. When the coil is properly designed, the inductor temperature rise will be around 40 °C above the ambient temperature. In case a warm lamp is switched off and on again, the inductor should not saturate at this inductor temperature.

Coil (L resonance)	
Ignition peak current	715.8 mA
E Peak Ignition	1075.9 mJ
Ignition frequency	86.3 kHz

019aab439

Fig 9. Requirements for coil design

3.2.4 Thermal properties

In this section the estimated dissipated power and the estimated junction temperature in the IC is calculated. See [Figure 10](#) for an example. When the maximum ambient temperature at which the lamp needs to operate is entered, the expected junction temperature is calculated. The junction temperature must not exceed 150 °C. If the junction temperature does exceed the 150 °C the expected operating life time of the IC is reduced significantly.

The maximum stress allowed during the ignition phase is 900 mA (peak) on the UBA2024 and 1.35 A (peak) on the UBA2024A at a case temperature of 25 °C (repetition rate is less than once per hour). The maximum stress period must not be longer than 1 s.

Thermal	
Ambient Temp	70 °C
Average powerloss in FET	0.56 W
Total power loss	0.74 W
Case temperature	128.6 °C
Junction temperature	140.5 °C

019aab440

Fig 10. Dissipated power and expected junction temperature in the IC

3.2.5 Literature reference

The formulas behind the calculations in the Excel spreadsheet are based upon [Ref. 1](#) and [Ref. 2](#).

3.3 Operating frequency

An operating frequency, f_{out} , of up to 60 kHz (the maximum nominal output frequency for the UBA2024, corresponding with a start-up frequency of 150 kHz. See the *UBA2024 data sheet* for start-up sequence description) can be selected. However, an f_{out} between 25 kHz and 30 kHz or between 40 kHz and 50 kHz is usually selected. This is because below 25 kHz there may be audible noise. Operation within the 30 kHz to 40 kHz band may result in interference with infrared remote controls. At higher than 50 kHz the third

harmonic is in the range where conducted emission requirements for most countries have to be met. Since inductors and capacitors decrease in size and cost with increase in frequency, the 40 kHz to 50 kHz range is preferred.

f_{out} is set by R_{OSC} and C_{OSC} according to [Equation 1](#):

$$f_{out} = \frac{I}{k_{OSC} \times R_{OSC} \times C_{OSC}} \tag{1}$$

Practical values for R_{OSC} range from 50 kΩ to 400 kΩ. Note that the lower the value of R_{OSC} , the higher the V_{DD} output current is going to be, thus increasing the total package dissipation. Practical values for C_{OSC} range from 100 pF to 1 nF. The advised value for C_{OSC} is 180 pF for 40 kHz to 50 kHz and 270 pF for 25 kHz to 30 kHz. [Figure 11](#) shows the oscillator constant k_{OSC} .

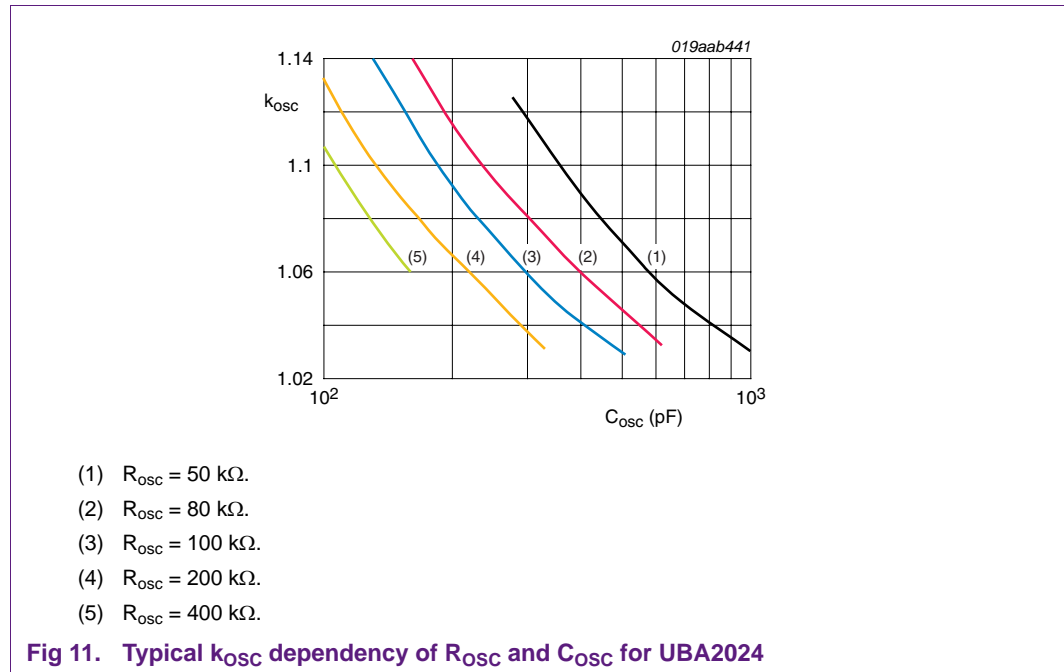

3.4 Ignition frequency and quasi-preheating

The IC output starting frequency is about 2.5 times the nominal output frequency and gradually decreases, depending on lamp type and temperature, until the nominal output frequency is reached. The lamp inductor (L_{LA}) and the lamp capacitor (C_{LA}) boost the lamp voltage gradually higher as the output frequency gets closer to their resonance frequency, until it is sufficient to ignite the lamp. In the meantime, the current in the resonance circuit flows through the filaments providing quasi-preheating.

The UBA2024 circuitry stops the frequency sweep at the resonance frequency, f_{rsn} , if the lamp has not ignited yet (see the UBA2024 data sheet for details). This ensures a maximum effort to ignite the lamp. The resonance frequency depends on L_{LA} and C_{LA} :

$$f_{rsn} = \frac{I}{2\pi \sqrt{L_{LA} \times C_{LA}}} \tag{2}$$

As the ignition frequency, f_{ign} , is higher than or equal to the resonance frequency the resonance frequency should be chosen so that the preferred ignition frequency is $1.6 \times f_{\text{out}} \leq f_{\text{ign}} \leq 1.8 \times f_{\text{out}}$.

The time needed to sweep down (set by C_{SW}) from the start frequency to the resonance frequency can be used as an approximation for the ignition time. The sweep time is typically C_{SW} (nF) \times 10.3 ms. The ignition time is shorter for large values because the lamp ignites before the resonance frequency is reached. The typical ignition time is 1 s when $C_{\text{SW}} = 330$ nF. A larger C_{SW} makes the sweep time longer and the preheating of the electrodes better. However, the rise of the preignition lamp ignition voltage is also slower. Both a quasi-preheat that is too short and a voltage rise that is too slow increase the glow time of the lamp. This reduces the lifetime of the lamp. During the glow phase, the lamp is ignited but the filaments and the gas inside the lamp are not at their final operating temperature.

The UBA2024 has a mechanism to push extra energy into the lamp during this glow phase. This makes the lamp go to its final light output quicker which gives a longer lifetime for the lamp. Typical values for C_{SW} are between 33 nF and 330 nF.

3.5 Choosing the other components

A bridge cell or separate diodes like the 1N5062 can be used for the rectifier bridge. The 1N4007 can also be used but these diodes are more sensitive to voltage spikes.

With a lamp current ≥ 150 mA with $C_{\text{DV}} = 220$ pF and for a current ≥ 150 mA with $C_{\text{DV}} = 100$ pF the value of C_{VDD} and C_{FS} is 10 nF.

The recommended half-bridge capacitors (C_{HB1} and C_{HB2}) are greater than 47 nF when $f_{\text{out}} = 40$ kHz to 50 kHz and greater than 68 nF when $f_{\text{out}} = 25$ kHz to 30 kHz.

The resonance frequency of the input pi filter, consisting of L_{FILT} and C_{HB} (C_{HB} being the effective capacitor as seen on the HV pin of the IC, i.e. the series capacitance of C_{HB1} and C_{HB2}), has to be at least two times lower than the nominal output frequency.

Remark: Performance and lifetime cannot be guaranteed by using the values given in this section. The lamp and the UBA2024 performance strongly interact with each other and need to be qualified together as a combination.

3.6 About component tolerances

Typical tolerances can be used (20 % for electrolytic capacitors, 10 % for other capacitors (foil or ceramic) and 5 % for resistors and inductors) for all components.

Since R_{OSC} , C_{OSC} and L_{LA} determine the lamp current, their tolerance also determines the spread in the lamp current. Therefore, the required lamp current accuracy may require closer tolerance for R_{OSC} , C_{OSC} and L_{LA} .

- **Example 1:** If $R_{\text{OSC}} = \pm 5\%$, $C_{\text{OSC}} = \pm 10\%$, $L_{\text{LA}} = \pm 5\%$, $C_{\text{LA}} = \pm 10\%$ and the internal frequency of the IC $= \pm 3\%$, the effective lamp current tolerance is 12.6 %.
- **Example 2:** If $R_{\text{OSC}} = \pm 1\%$, $C_{\text{OSC}} = \pm 5\%$, $L_{\text{LA}} = \pm 5\%$, $C_{\text{LA}} = \pm 5\%$ and the internal frequency of the IC $= \pm 3\%$, the effective lamp current tolerance is 7.1 %.

4. Quick measurements

Table 2 compares the calculated values from the application development tool with measured values.

Table 2. Measured values compared with the calculated values

Lamp power (W)	Power factor (pF)	Input voltage/frequency (V/Hz)	Input configuration	f _{out} set (kHz)	f _{out} measured (kHz)	L _{lamp} calculated (mA)	L _{lamp} measured (mA)	P burner (W)	P burner measured (W)
18.3	0.59	120/60	doubler	45.5	43.0	208	211	16.5	17.1
18.0	0.54	230/50	standard	45.5	45.6	218	204	16.5	16.6

5. Start-up and stop waveforms

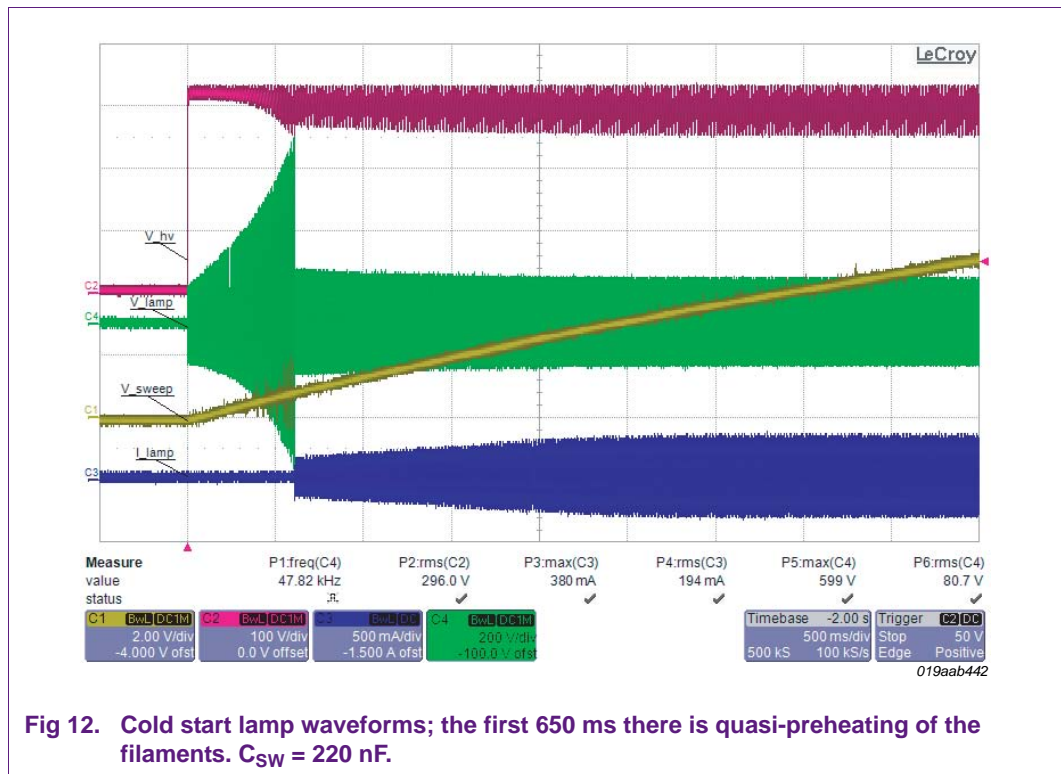

6. Layout considerations

The UBA2024 PCB layout, has a considerable influence on the performance of the IC. Issues to be taken into account are:

- Coils with open magnetic circuits should not be placed opposite the IC (on the other side of the PCB). If an axial filter inductor is used for L_{FILT} it should be placed in the same direction as the IC to minimize magnetic field pick-up.
- The oscillator pin (pin 7, RC) and the sweep pin (pin 8, SW) should be shielded from output/lamp by a ground track.
- Components on pins 7 and 8 should be placed as close to the IC as possible.
- Capacitors C_{VDD} and C_{FS} should be placed close to the IC.
- Mains input wires must not run parallel or near the half-bridge signal (pin 5, OUT) or near the output of the lamp inductor, bypassing the input filter.
- If the UBA2024(A)T is used, all SGND pins need to be soldered to a copper plane for effective heat transfer. This copper plane is underneath the IC and extends as much as possible on both sides of the IC. Fixing the IC to the board using thermal conductive glue also helps cooling the IC.

7. Application examples

7.1 Reference board

7.1.1 External lamp detection circuit

The NXP Semiconductors evaluation board has an additional lamp detection circuit which is not required in mass production applications like CFLi (see [Figure 13](#)). In this section the functioning of this detection circuit is described.

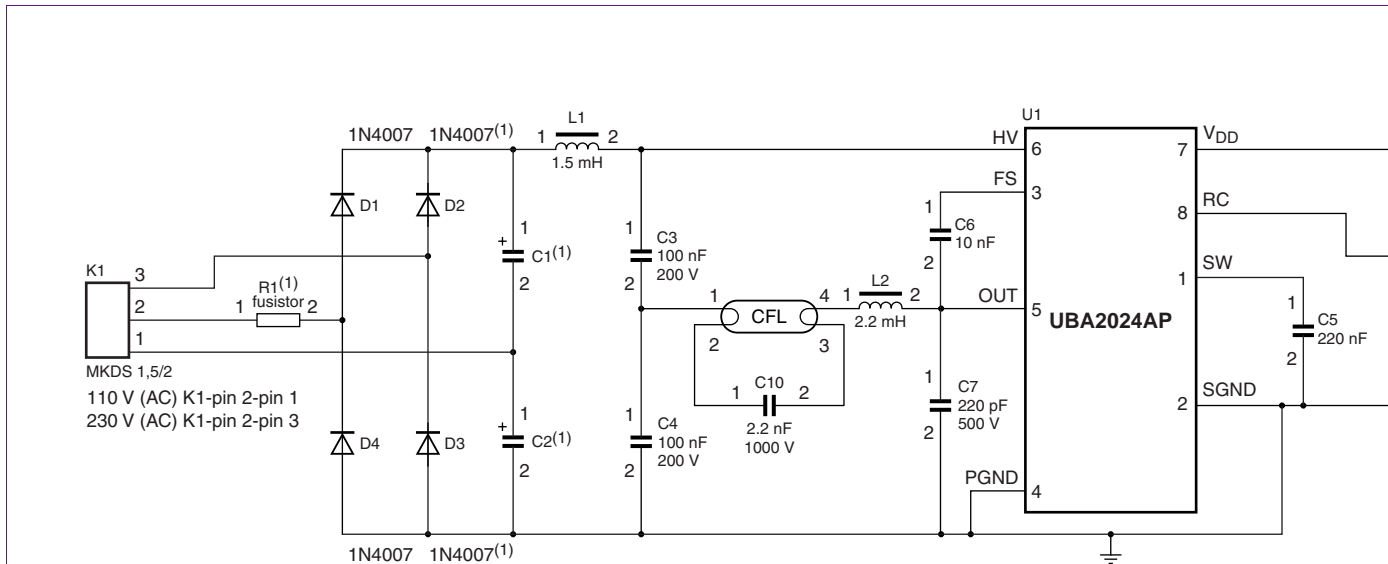

(1)NOTE! design combines 110V (AC) and 230V (AC)

120 V (AC):

R1 = 6.8 Ω/1 W

C1, C2 = 22 μF/200 V

D2 and D3 NOT mounted

K1 mounted on position 1, 2

230 V (AC):

R1 = 10 Ω/1 W

C1 = 10 μF/400 V

C2 = wire bridge

D1 to D4 are all mounted 1N4007

K1 mounted on position 2, 3

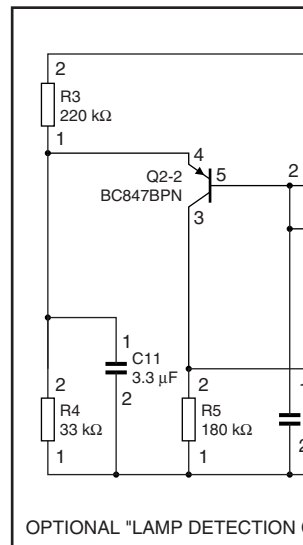

Fig 13. Circuit diagram demo board with optional lamp detection circuit

During start-up, in the quasi-preheat and the ignition phase, the voltage at the SW pin (pin 1) increases from 0 V to 3 V. At the same time, the amplitude of the signal on the RC pin (pin 7) increases by the same amount. However, if the lamp is not ignited because it is broken or missing, the sweep voltage stays below the 3 V level or even drop to 0 V. The IC will not operate in Zero Voltage Switching mode (ZVS). Large currents run through the half-bridge causing the dissipation in the IC to exceed the maximum value. The half-bridge can only withstand the high dissipation until the junction temperature reaches 150 °C.

At start-up, the RC oscillator starts with an amplitude of 2 V on pin RC (pin 7). The half-bridge frequency is now running at 2.5 times the nominal operating frequency. When the burner is connected to the circuit the half-bridge operates in ZVS and the C_{SW} capacitor charges. R6, R7 and C12 create an average DC voltage of the oscillator voltage on pin RC which is basically half the amplitude. That voltage is then fed to the base of Q2-2 which functions as a comparator.

At the same time that C_{SW} is charging, C11 is charged by R3 from V_{DD} . This takes place with a time constant of $(R3/R4) \times C11$. Charging stops when the voltage on C11 reaches 1.6 V. The voltage on C11 is fed to the emitter of Q2-2 to compare it with its base voltage.

Under normal conditions during start-up, when the lamp is connected, the average DC voltage from RC rises above 1.6 V at the end of the charging period for C11. The base emitter voltage of Q2-2 stays reverse biased and will not turn on. If, however, non-ZVS is detected in the switches of the half-bridge driver, because of an unconnected or broken lamp, charging of C_{SW} stops and the voltage on C_{SW} drops to 0 V. The average DC voltage on the RC pin lowers to less than 1 V and Q2-2 starts to conduct.

Q2-2 drives the latching transistor Q1-1 and the fault condition is latched by the left diode of the double diode, D5. At the same time the right diode of D5 stops the UBA2024 half-bridge oscillator. The latch can be reset by power cycling the mains voltage with less than 1 s delay (for the test circuit this depends on the discharge time of C11 and R4). The latch circuit is designed in such a way that it is not noise sensitive. However, it is better to keep it away from the large signal tracks.

Typically, the circuit triggers within 0.5 s from start-up when no lamp is connected. It also triggers when a lamp is removed while operating. When the protection is tripped, the dissipated power in the IC is approximately 0.6 W. The IC can dissipate this power continuously.

Ensure that there is some reaction time margin (at room temperature) when choosing C11. Also, consider voltage de-rating of MLCC capacitors when low voltage types are used. It is advisable to choose an X7R type or an X5R type of at least 10 V.

The protection circuit puts some additional capacitive loading (about 5 pF) on pin RC. This can become significant for small values of C_{OSC} . In this case the value of C_{OSC} is compensated for this effect by lowering R_{OSC} from 200 k Ω to 191 k Ω (E96 series), giving an operating frequency of 45.9 kHz instead of 43.3 kHz. When the circuit is used it is advisable to add the extra 5 pF to C_{OSC} in [Equation 1](#).

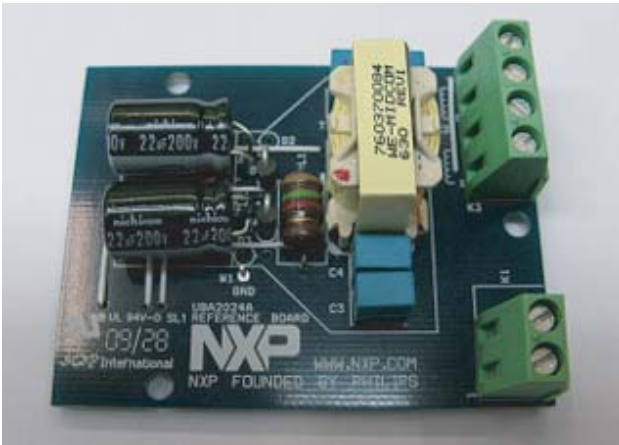

019aab444

Fig 14. Photo reference board UBA2024T/AT (120 V (AC) version)

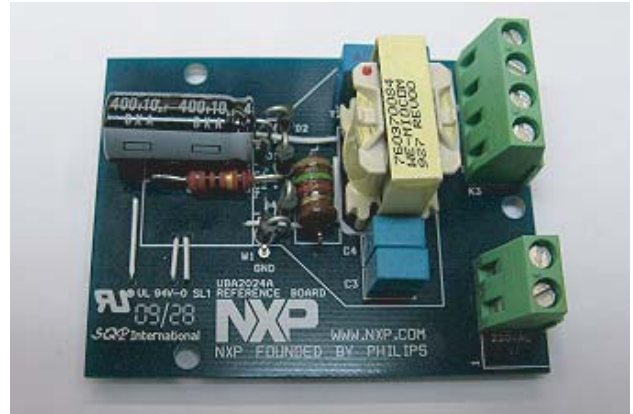

019aab445

Fig 15. Photo reference board UBA2024T/AT (230 V (AC) version)



019aab446

Fig 16. Photo reference board UBA2024P/AP (120 V (AC) version)



019aab447

Fig 17. Photo reference board UBA2024P/AP (230 V (AC) version)

Table 3. Component values used for testing with 18 W PLC burner

Reference	Description	Remarks	Value/type 230 V (AC)	Value/type 120 V (AC)
R _{FUS}	fusible inrush current limiter resistor	-	10 Ω/1 W	6.8 Ω/1 W
D1, D4	mains rectifier diodes	-	1N4007	1N4007
D2, D3	mains rectifier diodes	-	1N4007	not mounted
C _{BUF1}	buffer capacitor	-	10 μF/400 V	22 μF/200 V
C _{BUF2}	buffer capacitor	high temperature electrolytic type	not mounted, place wire	22 μF/200 V
L _{FILT}	filter inductor	axial type	1.8 mH	1.8 mH
C _{HB1} , C _{HB2}	half-bridge capacitors	-	100 nF/250 V (DC)	100 nF/250 V (DC)
C _{LA}	lamp capacitor	film type, capable of withstanding peak voltages of twice its DC-rating	2.2 nF/700 V (DC)	2.2 nF/700 V (DC)
L _{LA}	lamp inductor	E20-core	2.2 mH	2.2 mH
C _{DV}	dV/dt limiting capacitor	-	220 pF/500 V (DC)	220 pF/500 V (DC)
C _{FS}	floating supply buffer capacitor	-	10 nF/50 V	10 nF/50 V
C _{VDD}	low voltage supply buffer capacitor	-	10 nF/50 V	10 nF/50 V
C _{OSC}	oscillator capacitor	2 %	100 pF/50 V	100 pF/50 V
R _{OSC}	oscillator resistor	1 %	191 kΩ/0.125 W	191 kΩ/0.125 W
C _{SW}	sweep time capacitor	-	220 nF/25 V	220 nF/25 V

Table 4. Components values for the optional lamp detection circuit

Reference	Description	Remarks	Value/type
R3	-	-	220 kΩ/0.125 W
R4	-	-	33 kΩ/0.125 W
R5	-	-	180 kΩ/0.125 W
R6, R7	-	-	1 MΩ/0.125 W
C11	ignition time-out capacitor	MLCC X7R type or an X5R type with a voltage rating ≥ 10 V	3.3 μF/10 V
C12	-	ceramic or MLCC C0G type	220 pF/16 V
D5	double diode common cathode	-	BAV70W
Q1-1, Q2-2	PNP/NPN transistor in one package or use separate transistors (see below).	h _{FE} > 100 at 10 μA	BC847BNP
	Q1-1	h _{FE} > 100 at 10 μA	BC847B
	Q2-2	h _{FE} > 100 at 10 μA	BC857B

7.2 UBA2024 with additional feed-forward circuit

7.2.1 Introduction

With a typical half-bridge topology, the output power and current depends on the bus voltage. When the mains voltage increases the dissipated power increases. This could cause lamp failure or the IC junction temperature to exceed the maximum allowed temperature (150 °C). This can be prevented by implementing a feed-forward circuit. With feed-forward, a higher bus voltage causes a higher operating frequency and a lower half-bridge current which in turn compensates for the bus voltage increase.

Typically, a feed-forward circuit is only needed if the mains voltage increases by up to 30 % for a long period of time (which only occurs in a few countries in the world). The application development tool calculation shows how much power is put in the lamp and what the resulting current will be. This limit differs from application to application.

7.2.2 Implementation

Feed-forward can easily be applied via the additional circuit R1, R2 and Q1 as shown in [Figure 18](#). The system should be designed so that the feed-forward circuit does not inject current in C_{OSC} at the typical operating point of the lamp. In a 230 V (AC) mains system, the circuit should not operate at a voltage below $\sqrt{2} \times 230 \text{ V (AC)} = 325 \text{ V}$. This circuit starts to inject current in the oscillator capacitor when V_{HV} equals:

$$V_{HV} = (V_{VDD(min)} + 0.7) \left(1 + \frac{RI}{R2} \right) \quad (3)$$

In the example of [Figure 18](#) this yields:

$$V_{HV} = (11.7 + 0.7) \left(1 + \frac{2.0M}{78.7k} \right) = 328V \quad (4)$$

Above 328 V the injected current into the oscillator pin equals:

$$\Delta I_{CF} = \frac{\Delta V_{bus}}{RI} = \frac{\Delta V_{bus}}{2.0M} \quad (5)$$

Results:

An 18 W CFL circuit has been applied with and without feed-forward as described above. The results can be seen in [Figure 19](#).

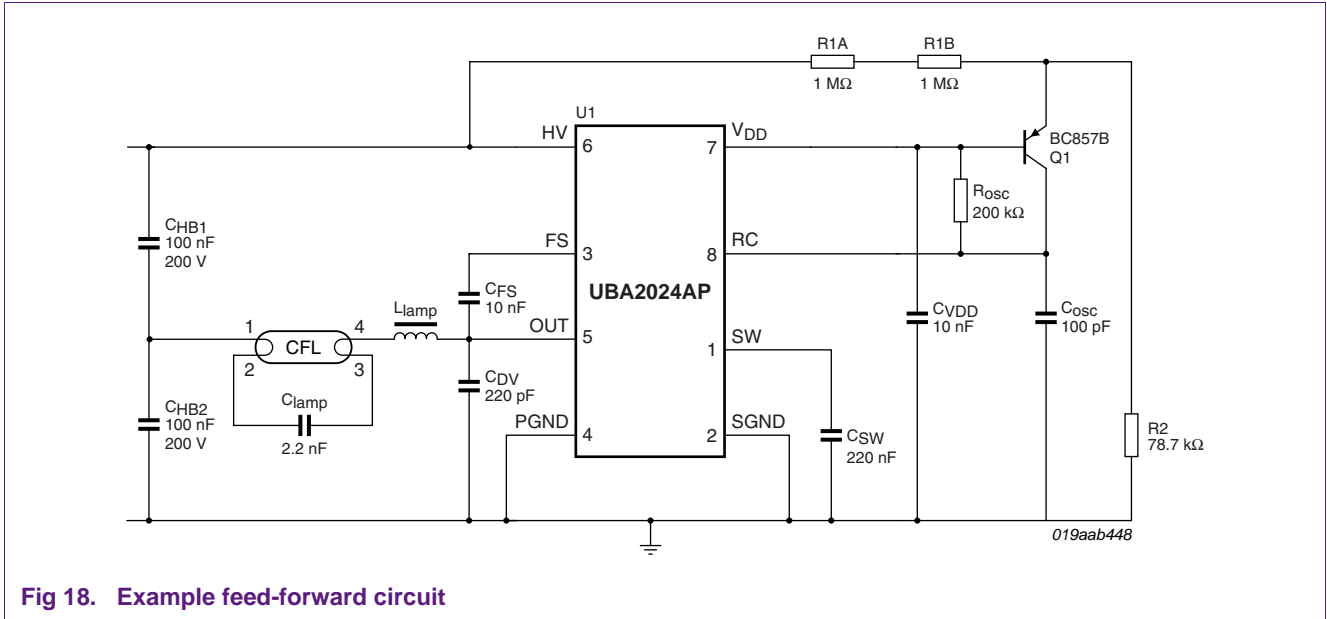

Fig 18. Example feed-forward circuit

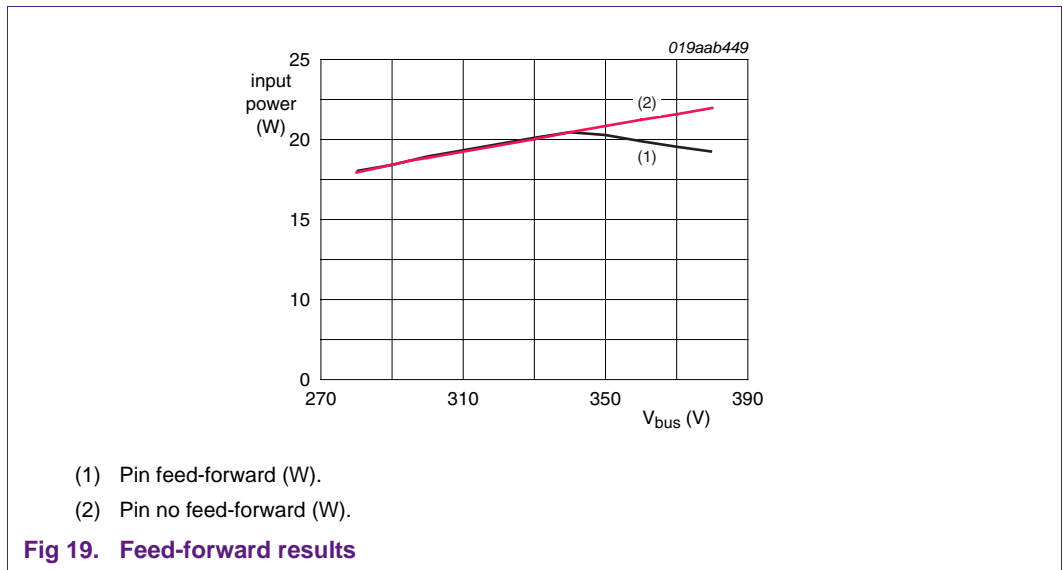

Fig 19. Feed-forward results

7.3 Driving a CCFL lamp with the UBA2024

Using a transformer instead of a coil, the UBA2024P can be used to drive Cold Cathode Fluorescent Lamps (CCFL). [Figure 20](#) shows the circuit diagram for a CCFL application. Due to EMI, a high voltage (2 kV) capacitor of 2.2 nF may need to be connected to pin 1 of the primary winding (grounded side) and to pin 3 of the secondary winding.

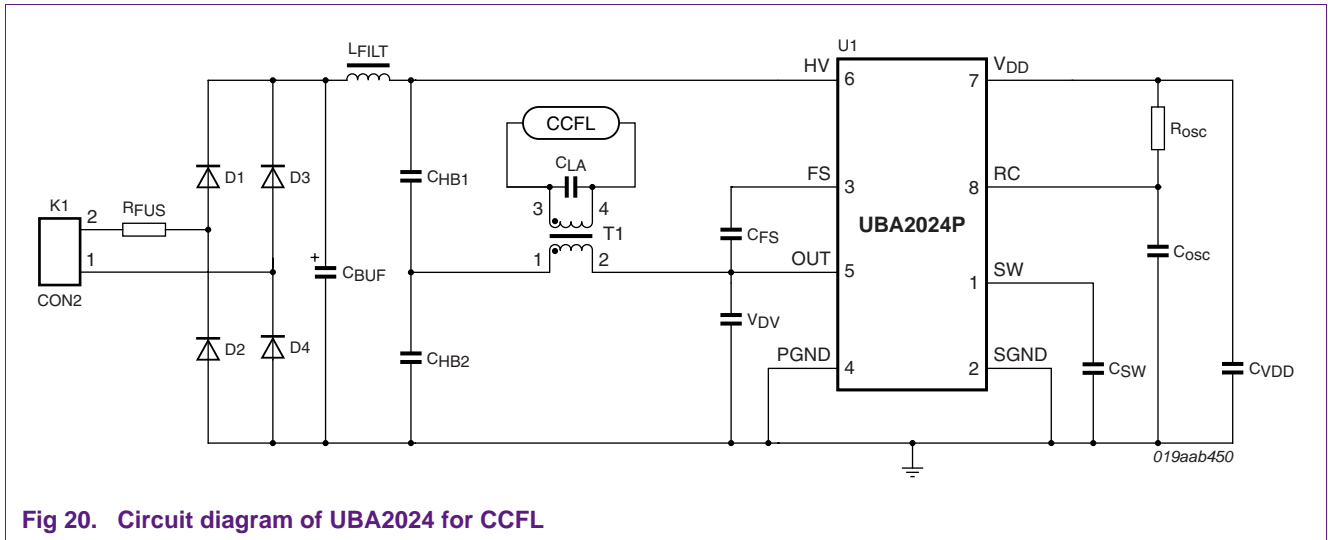

Fig 20. Circuit diagram of UBA2024 for CCFL

7.4 UBA2024 in a replaceable lamp configuration (matchbox ballast)

The UBA2024 in [Figure 21](#) is not powered unless a lamp is in place. Therefore, when a lamp is replaced it automatically starts when the new lamp is inserted. This is particularly useful when the UBA2024 is used in so-called 'matchbox' ballasts driving 4-pin, PL-C, Dulux D/E Dulux T/E, DBX or TBX type of burners.

Since the IC is intended for use in low cost integrated CFL applications, it lacks an open or no-load protection circuit. Therefore, the protection circuit, as described in [Section 7.1.1](#) and shown in [Figure 13](#), is a requirement for this application. Using only three resistors and a single transistor, an optional feed-forward circuit can be added, limiting the lamp power if the mains voltage becomes too high. This extends the lamp lifetime. The UBA2024AP is a recommended component to drive the higher power burners of up to 18 W.

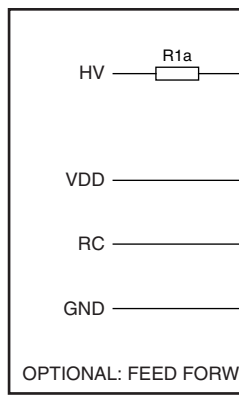
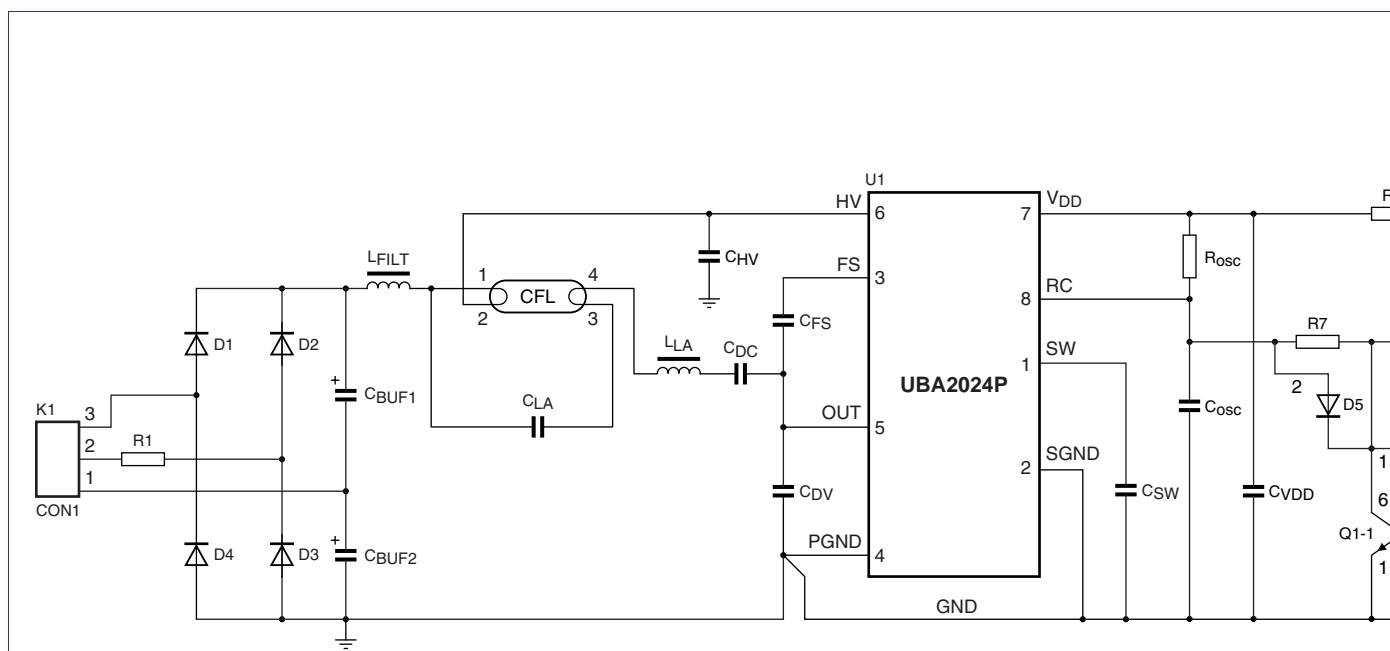

Fig 21. Circuit diagram for replaceable lamp with required protection and optional feed-forward

AN10713

All information provided in this document is subject to legal disclaimers.

© NXP B.V. 2011. All rights reserved.

Table 5. Component values used for replaceable 18 W burner (80 V /210 mA)

Reference	Description	Remarks	Value/type 230 C (AC)	Value/type 120 V (AC)
R _{FUS}	fusible inrush current limiter resistor	-	10 Ω/1 W	6.8 Ω/1 W
D1, D4	mains rectifier diodes	-	1N4007	Not mounted
D2, D3	mains rectifier diodes	-	1N4007	1N4007
C _{BUF1}	buffer capacitor	-	10 μF/400 V	22 μF/200 V
C _{BUF2}	buffer capacitor	high temperature electrolytic type	not mounted, place wire	22 μF/200 V
L _{FILT}	filter inductor	axial type	1.8 mH	1.8 mH
C _{dc}	half-bridge capacitor	-	150 nF/400 V (DC)	150 nF/400 V (DC)
C _{LA}	lamp capacitor	film type, capable of withstanding peak voltages of twice its DC-rating	2.2 nF/700 V (DC)	2.2 nF/700 V (DC)
L _{LA}	lamp inductor	E20-core	2.1 mH	2.1 mH
C _{DV}	dV/dt limiting capacitor	-	220 pF/500 V (DC)	220 pF/500 V (DC)
C _{FS}	floating supply buffer capacitor	-	10 nF/50 V	10 nF/50 V
C _{VDD}	low voltage supply buffer capacitor	-	10 nF/50 V	10 nF/50 V
C _{OSC}	oscillator capacitor	2 %	100 pF/50 V	100 pF/50 V
R _{OSC}	oscillator resistor	1 %	191 kΩ/0.125 W	191 kΩ/0.125 W
C _{SW}	sweep time capacitor	-	220 nF/25 V	220 nF/25 V

Table 6. Components values for the lamp detection circuit and optional feed forward

Reference	Description	Remarks	Value/type
R1A, R1B	optional; feed forward	-	1 MΩ/0.125 W
R2	optional; feed forward	-	78.7 kΩ/0.125 W
R3	-	-	220 kΩ/0.125 W
R4	-	-	33 kΩ/0.125 W
R5	-	-	180 kΩ/0.125 W
R6, R7	-	-	1 MΩ/0.125 W
C11	ignition time-out capacitor	MLCC X7R type or X5R type	3.3 μF/10 V
C12	-	ceramic or MLCC C0G type	220 pF/16 V
D5	double diode common cathode	-	BAV70W
Q1-1, Q1-2	PNP/NPN transistor in one package or use separate transistors (see below).	$h_{FE} > 100$ at 10 mA	BC857B/BC847 or BC847BNP
	Q1-1	$h_{FE} > 100$ at 10 mA	BC847B
	Q2-2	$h_{FE} > 100$ at 10 mA	BC857B
Q2	optional; feed forward	-	BC857B

8. Improved preheat

In this section an improved preheat methodology is explained, in which the starting frequency is set and consequently the time needed to reach ignition frequency. The circuitry connected to pin SW has therefore changed compared to the application as shown in the data sheet of the UBA2024. The new preheat circuit is shown in [Figure 22](#).

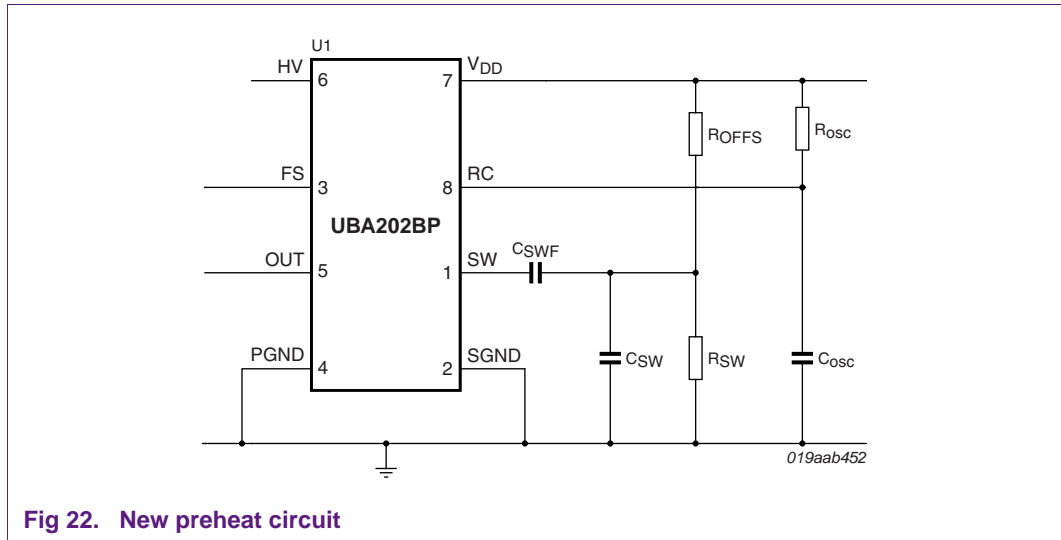

Fig 22. New preheat circuit

A controlled preheat current where the current would appear as shown in [Figure 23](#) is not possible. There is no free pin available and a sense resistor would lead to additional power losses.

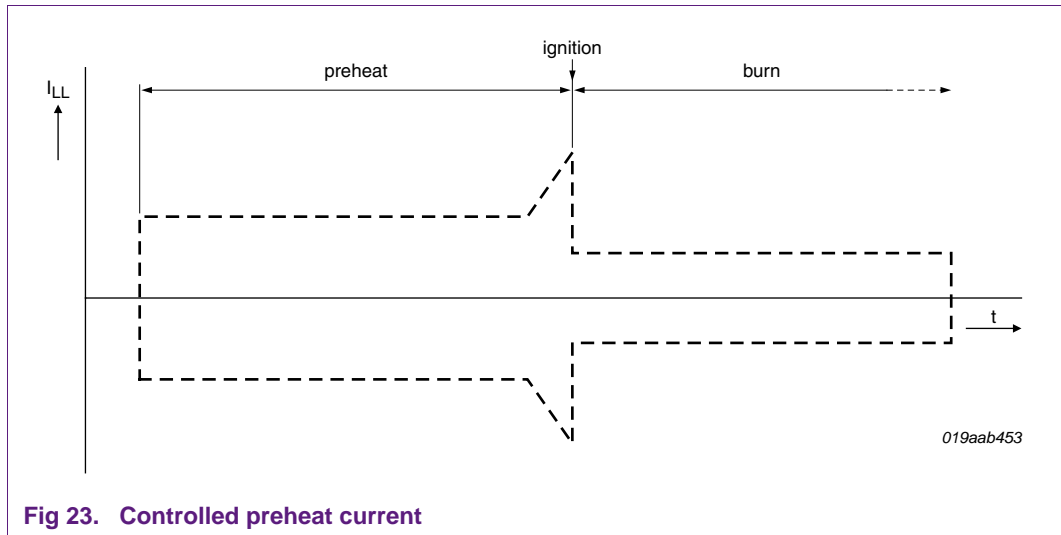

Fig 23. Controlled preheat current

The following sections of this chapter describe how a controlled preheat can be approximated for the typical application shown in this application note (see [Figure 1](#) and [Figure 2](#)). Proof of concept is shown in [Section 9](#) that this approximation of a controlled preheat is an adequate solution for preventing lamp glow.

If the filament specifications are unknown, a guideline is that the optimal ratio between the filament resistance at ignition and cold filament resistance is approximately 5 : 1. Using a preheat time of 500 ms to 600 ms this ratio can be reached. With a cold start not only is the ignition voltage higher but also the starting voltage. Both ignition and starting cause more damage during a cold start.

8.1 Start-up of an application with the new preheat circuit

The time needed to sweep down (set by C_{SW} only as R_{SW} is not present when the IC is used in the typical application shown in the *UBA2024 data sheet*) from the start frequency to the resonance frequency can be used as an approximation for the ignition time.

The sweep time is typically $C_{SW} \text{ nF} \times 10.3 \text{ ms}$. The ignition time is shorter for large values because the lamp ignites before the resonance frequency is reached. The typical ignition time is 1 s when $C_{SW} = 330 \text{ nF}$. A larger C_{SW} increases the sweep time and improves the preheating of the electrodes. However, the rise of the pre-ignition lamp ignition voltage is also slower. Both a quasi-preheat that is too short and a voltage rise that is too slow increase the glow time of the lamp. This reduces the lifetime of the lamp. During the glow phase the lamp is ignited but the filaments and the gas inside the lamp are not at their final operating temperature. The UBA2024 has a mechanism to push extra energy into the lamp during this glow phase which is described in the *UBA2024 data sheet*. This makes the lamp reach its final light output faster giving a longer lamp lifetime. Typical values for C_{SW} are between 33 nF and 330 nF when the IC is used in a typical application.

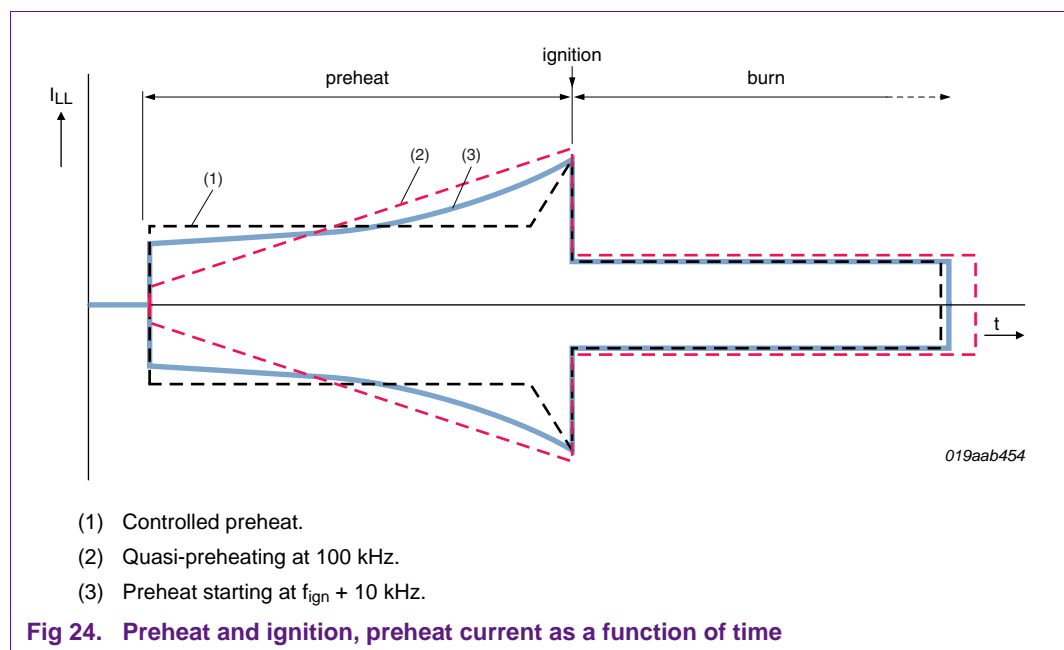

In [Figure 22](#), a schematic diagram of the SW circuitry is shown which also provides a starting frequency of approximately 10 kHz above the ignition frequency.

In this operation, the operating frequency is still determined by R_{OSC} and C_{OSC} according to [Equation 1](#). The starting frequency is determined by the offset voltage that is determined by the voltage divider R_{OFFS} and R_{SW} .

Capacitor C_{SW} now works as a filter for this offset voltage. After start up C_{SWF} is charged further until the IC has reached the operating frequency. This preheating method is similar to curve (3) shown in [Figure 24](#).

The component values used in a 230 V/18 W UBA2024AP application using the new preheat circuit are $C_{SWF} = 470 \text{ nF}$, $C_{SW} = 10 \text{ nF}$, $R_{SW} = 10 \text{ k}\Omega$, $C_{OSC} = 220 \text{ pF}$, $R_{OSC} = 100 \text{ k}\Omega$ and $R_{OFFS} = 430 \text{ k}\Omega$.

9. Lamp glow

Lamp glow is mainly caused by incorrect preheating of the filaments. Either a quasi-preheat that is too short or a voltage rise that is too slow increase the glow time of the lamp. This reduces the lifetime of the lamp. During the glow phase the lamp is ignited but the filaments and the gas inside the lamp are not at their final operating temperature.

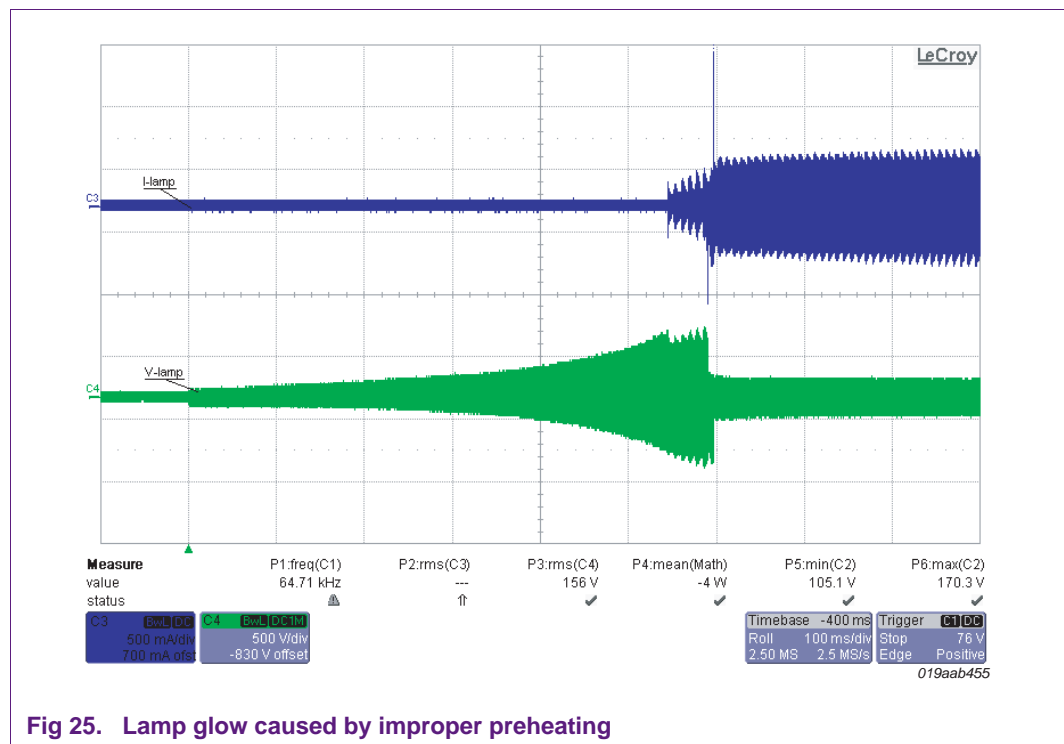

Fig 25. Lamp glow caused by improper preheating

In [Figure 25](#), it is clear that there is still a high voltage present at the lamp while at the same time lamp current is flowing. When the filaments and gas inside the lamp have reached their normal operating temperature, the voltage at the lamp will drop to its normal operating value.

This is the preheating method shown in [Figure 24](#) referred to as Quasi-preheat and starts at 100 kHz.

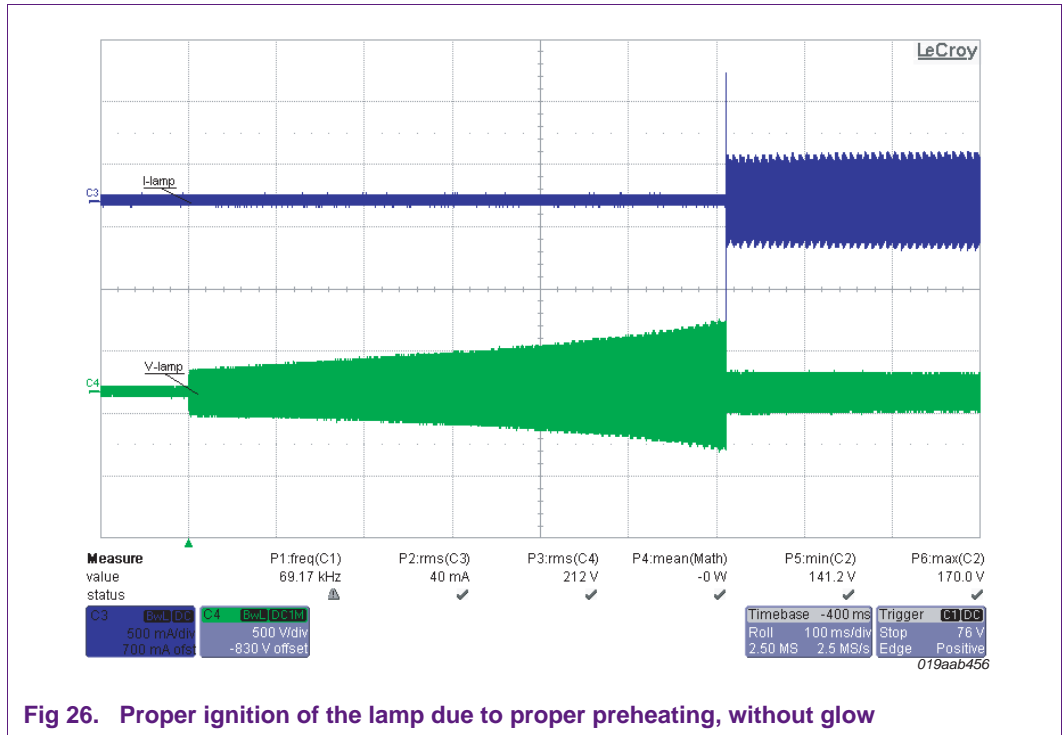

Fig 26. Proper ignition of the lamp due to proper preheating, without glow

Figure 26 shows the ignition of a lamp that is preheated as shown in Figure 24 according to the blue line, where preheating starts at the ignition frequency plus an additional 10 kHz. There is no lamp glow present due to the filaments having enough time to reach the correct operating temperature. This method of preheating increases lamp lifetime and ensures it passes any on/off test of 10,000 repetitions minimum.

10. Coil saturation

Figure 27 illustrates what happens when the coil goes into saturation during ignition.

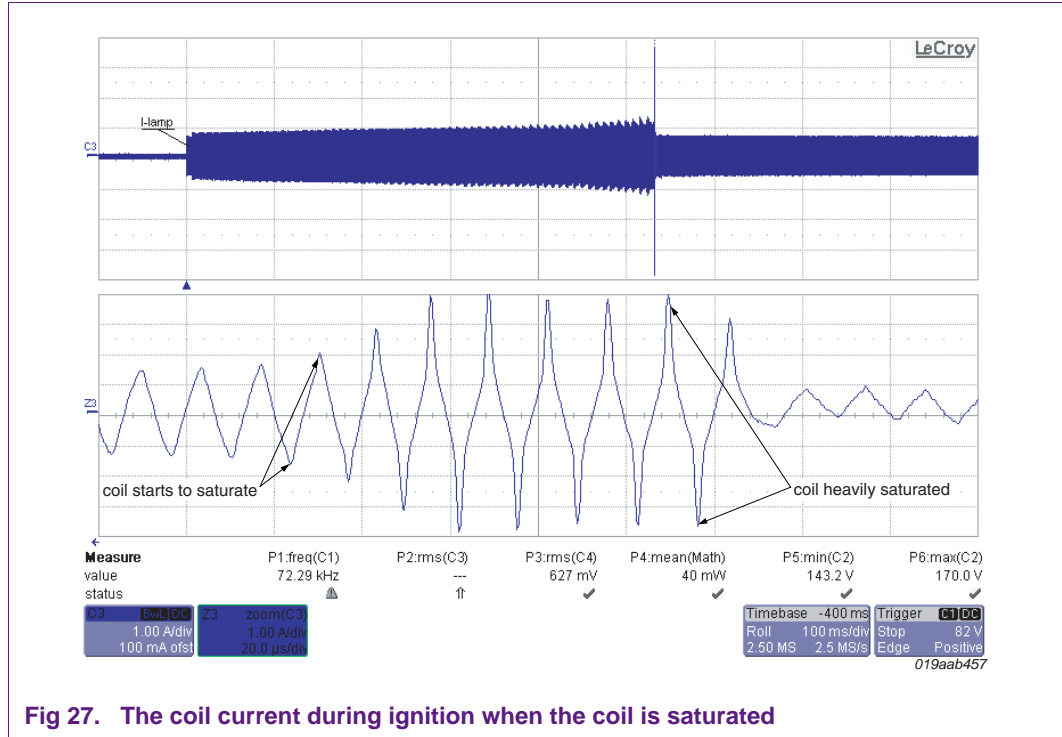

Fig 27. The coil current during ignition when the coil is saturated

In this case, the coil current shows excessive peaks which results in the integrated half-bridge switches going into saturation and consequently damaging the IC.

The test circuit shown in Figure 28 provides a simple method to determine the saturation current of an inductor.

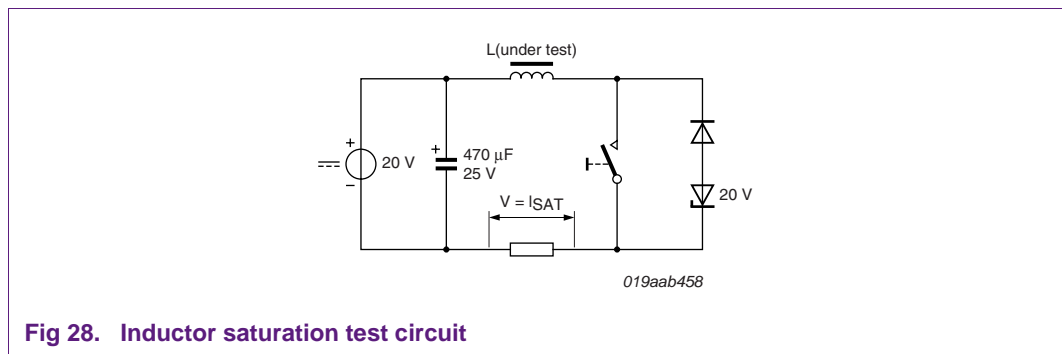

Fig 28. Inductor saturation test circuit

The electrolytic buffer capacitor is charged by the 20 V power supply and is discharged through the inductor when the push-button switch is pushed. The inductor current can be measured as the voltage over the 1 Ω resistor. The diode circuit clamps the voltage peak over the push-button switch when it is released. An example of the inductor current is shown in Figure 29.

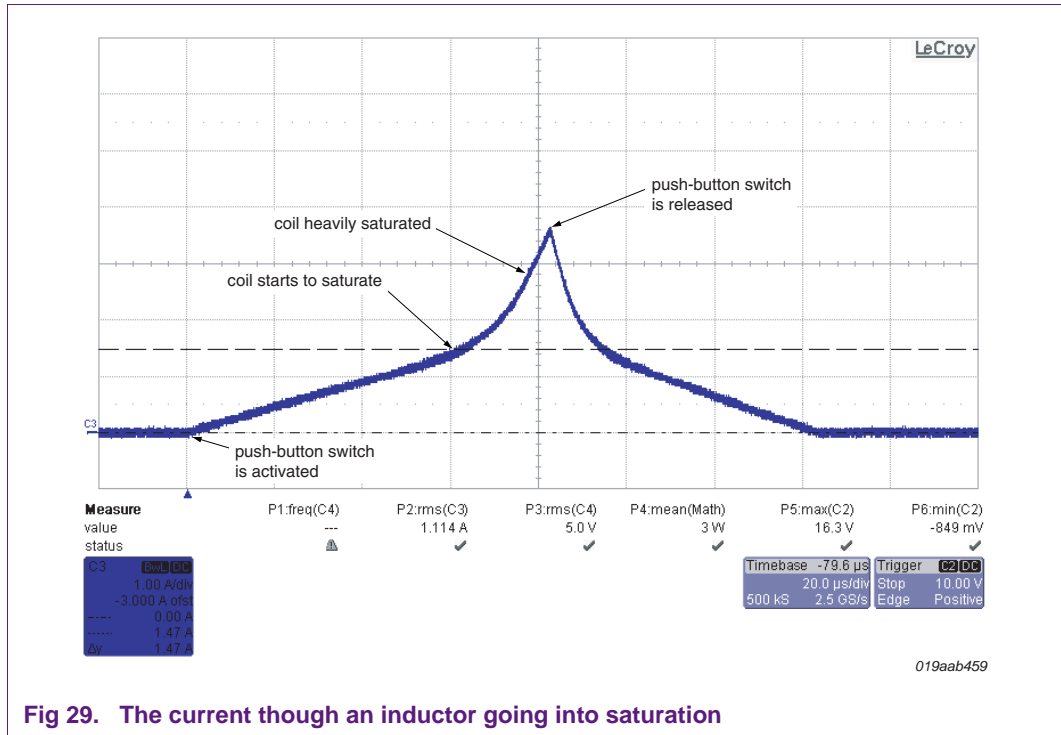

Fig 29. The current through an inductor going into saturation

As long as the inductor is not saturated, the current through the windings builds up linearly until the moment that the coil saturates. At that moment a rapid current increase can be observed, as indicated in [Figure 29](#).

When an application is used under extreme conditions such as a combination of maximum possible mains voltage and high temperature a well designed inductor can still go into saturation during ignition. To correct for such boundary conditions, a protection circuit is presented to keep the application from breaking down when coil saturation occurs.

The best method to prevent coil saturation is to use a properly designed inductor with good coil material and that the presented method is no excuse to use a poor dimensioned inductor coil.

The basic principle is that when the coil current increases to an excessive value (as is the case at coil saturation) extra charge is fed into the sweep capacitor C_{SWF} . As a result the frequency very quickly drops towards its minimum value and during this fast frequency decrease the lamp ignites earlier.

This drastically reduces the time that excessive current is flowing through the half-bridge FETs.

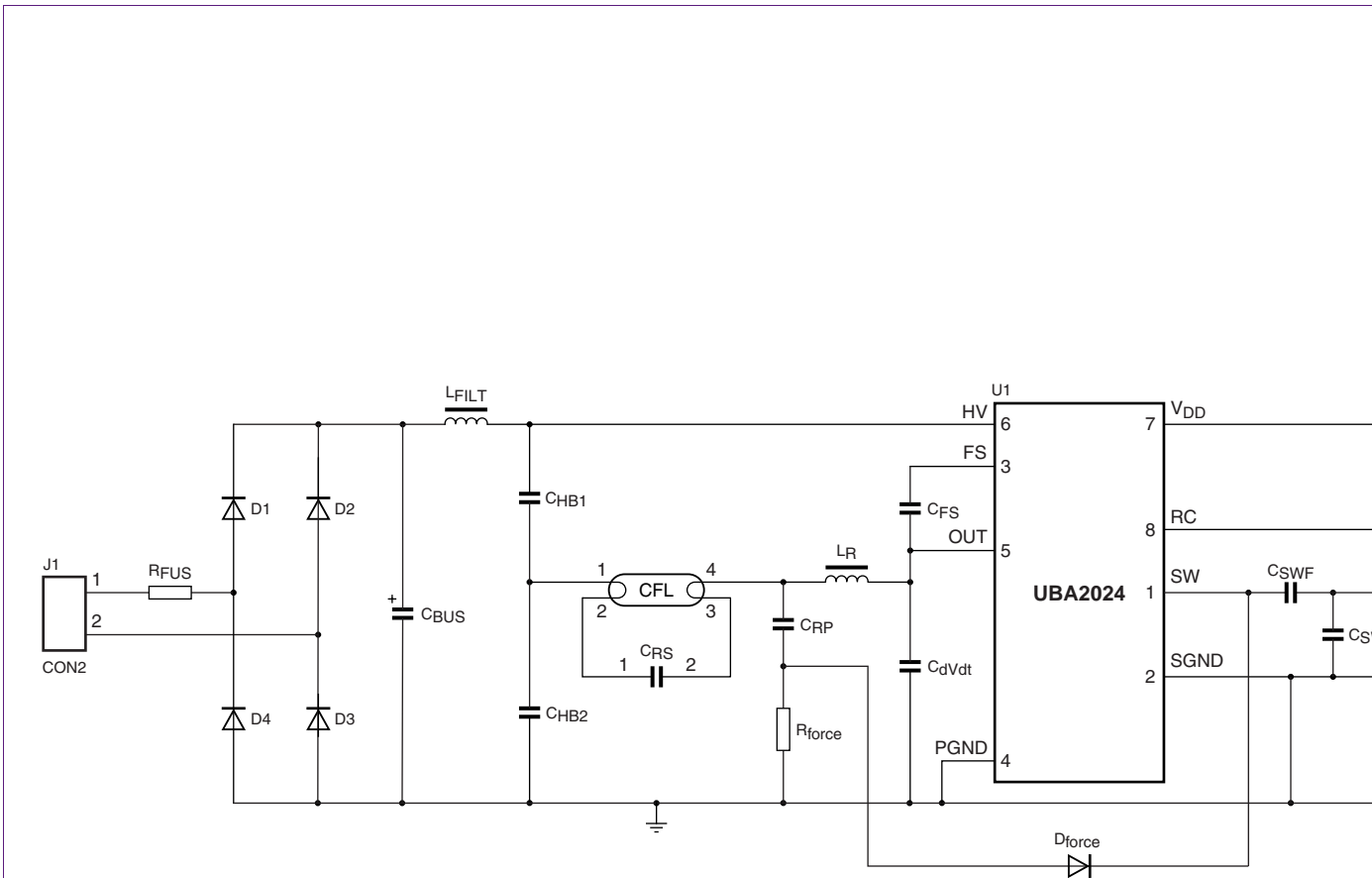
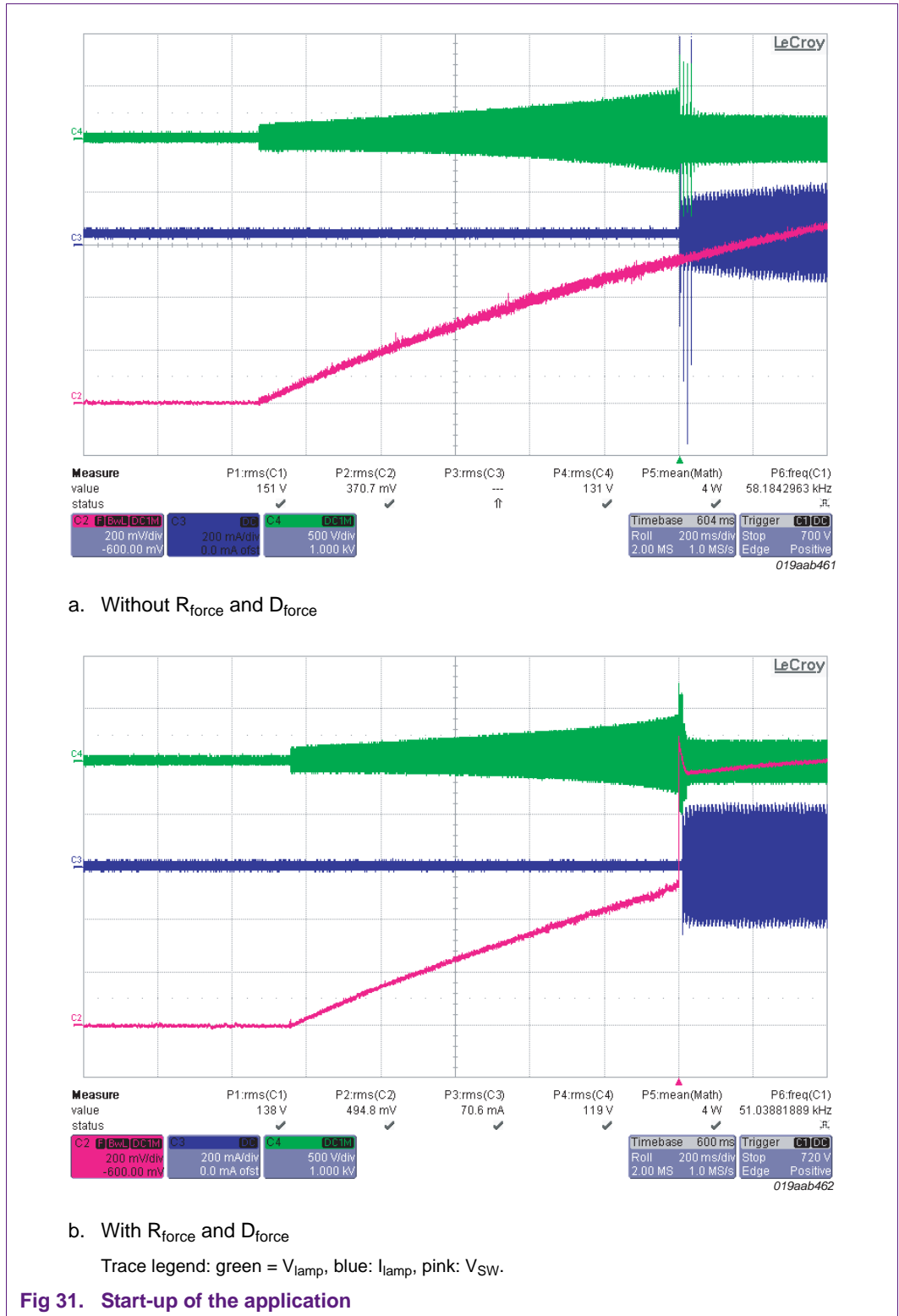
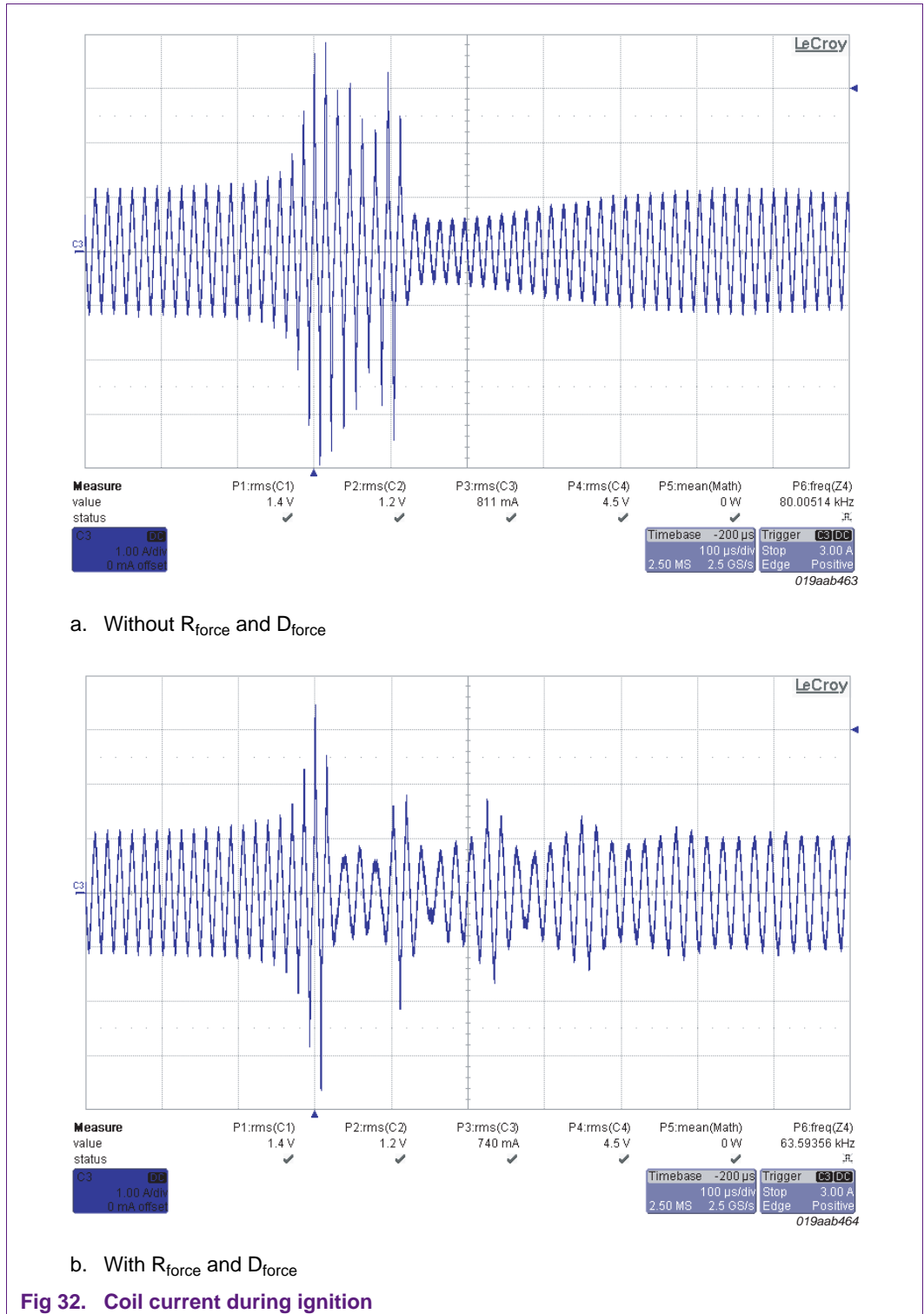

Fig 30. UBA2024 application with improved preheat and saturation protection

The resonant capacitor is split up in C_{RS} and C_{RP} , so the total resonance capacitance equals $C_{RS} + C_{RP}$. A part of the coil current also flows through C_{RP} and this current is sensed by R_{force} . C_{RP} and R_{force} are chosen such that when the coil goes in to saturation, the voltage over R_{force} exceeds the sum of the normal operating voltage on the SW pin and the forward voltage of D_{force} . If that is the case extra charge is fed into C_{SW} and the IC will be immediately forced towards ignition. D_{force} must be a low leakage diode.



The waveforms during start-up are shown in [Figure 31](#). The next figures will show the inductor current during coil saturation in more detail.



It is clear that when the coil goes into saturation, several bursts of saturation current peaks can be observed, see [Figure 31\(a\)](#). The current peaks as shown in [Figure 32\(a\)](#) can reach very high values during several periods which can destroy the IC. [Figure 32\(b\)](#) shows the coil current for the same application with R_{force} and D_{force} installed.

The number of saturation current peaks has decreased significantly and the current's peaks are lower. In this way, the application can survive an extreme condition as described at the beginning of this section.

11. Thermal behavior

This section describes some measurements and results of thermal behavior of UBA2024AP and UBA2024AT reference PCB's in their actual 18 W CFL applications. The case temperature and ambient temperature were measured with thermocouples directly on the center of the IC package and 1 cm above the IC, respectively.

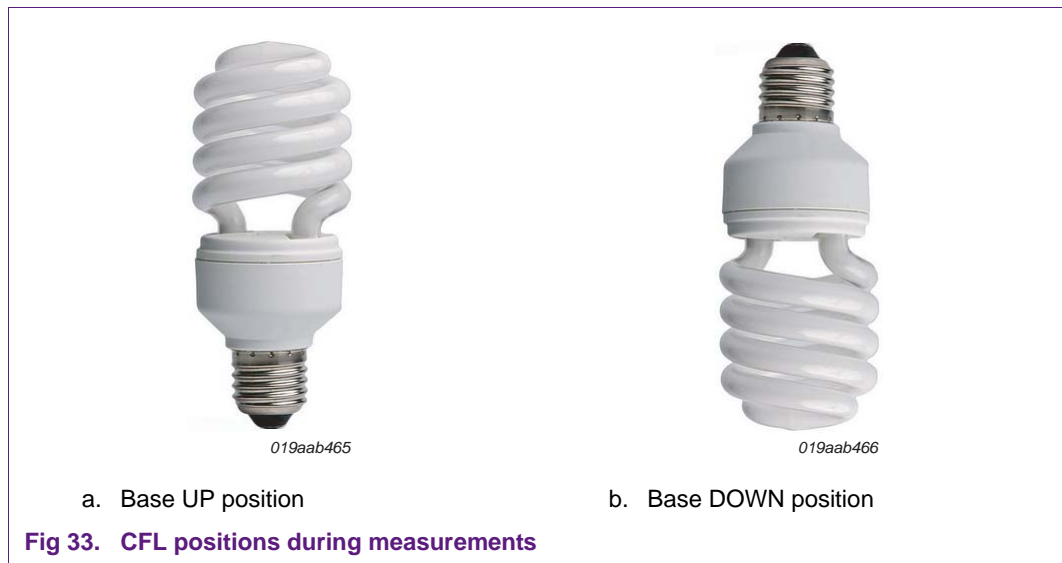

The first measurements are performed to get a reliable measurement of the junction temperature in the application. The tests are carried out in base up and base down positions (see [Figure 33](#)).

Table 7. Temperatures in an application

IC and application	Base orientation	P _{MAINS} (W)	IC	
			T _{amb} (°C)	T _{case} (°C)
UBA2024AP 230 V/18 W	up	17.6	89	110
	down	15.9	68	86
UBA2024AT 230 V/18 W	up	17.8	86	103
	down	17.4	66	80

In the next measurement, the IC temperature is measured as a function of the half-bridge FET current. The current through the FET's is regulated by varying the mains voltage using a variac. The application was placed in a high hat in a base up position.

Table 8. UBA2024 IC case temperature as function of FET current

V _{MAINS} (V)	I _{FET} (mA)		P _{MAINS} (W)		T _{case} (°C)	
	AP	AT	AP	AT	AP	AT
150	113	113	10.4	10.8	74	69
175	142	139	13.2	13.8	85	78
200	169	168	15.2	16.4	95	95
230	202	196	17.5	19.2	113	112
260	232	225	19.6	21.6	128	124
285	260	247	21.5	23.6	153	146

The case temperature given in [Table 8](#) is shown in a graphical representation in [Figure 34](#).

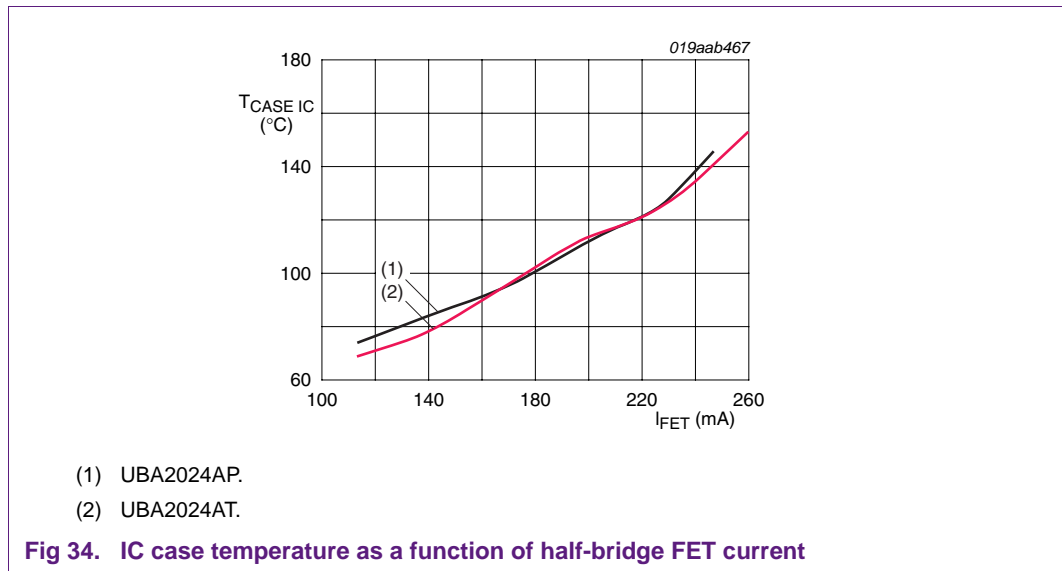

11.1 Junction temperature measurements

With MOSFETs, there is a good correlation between junction temperature and the on-state resistance of the switching device, the R_{DSon}. The resistance R_{DSon} increases linearly over temperature and is representative of the junction temperature. The multiplication factor of this increase depends on the process of the MOSFET and can be measured. The resistance increase per °C equals:

$$\frac{\Delta R}{\Delta T} = \frac{R_{DSon@150^{\circ}C} - R_{DSon@25^{\circ}C}}{150 - 25} [m\Omega/^{\circ}C] \tag{6}$$

The correlation factor between temperature and the on-state resistance R_{DSon} of the MOSFETs is identical for all EZ-HV MOSFETs and amounts 1.7 which means that:

$$R_{DSon@150^{\circ}C} = 1.7 \cdot R_{DSon@25^{\circ}C} \tag{7}$$

This correlation factor will be used for the calculations. The junction temperature will be calculated using [Equation 8](#):

$$T_j = T_{amb} + \frac{(R_{D_{Son,operating}} - R_{D_{Son,ambient}})}{\Delta R / \Delta T} \tag{8}$$

11.2 R_{DSon} measurements in the CFL application

This section describes a method to measure the R_{DSon} in a working application. The output voltage of the half-bridge V_{OUT} has been measured during the time that the low-side MOSFET is on. At that moment V_{OUT} = V_{DS} (Low Side). V_{OUT} has a voltage range of approximately 325 V, so a voltage clamp is needed for an accurate measurement, see [Figure 35](#).

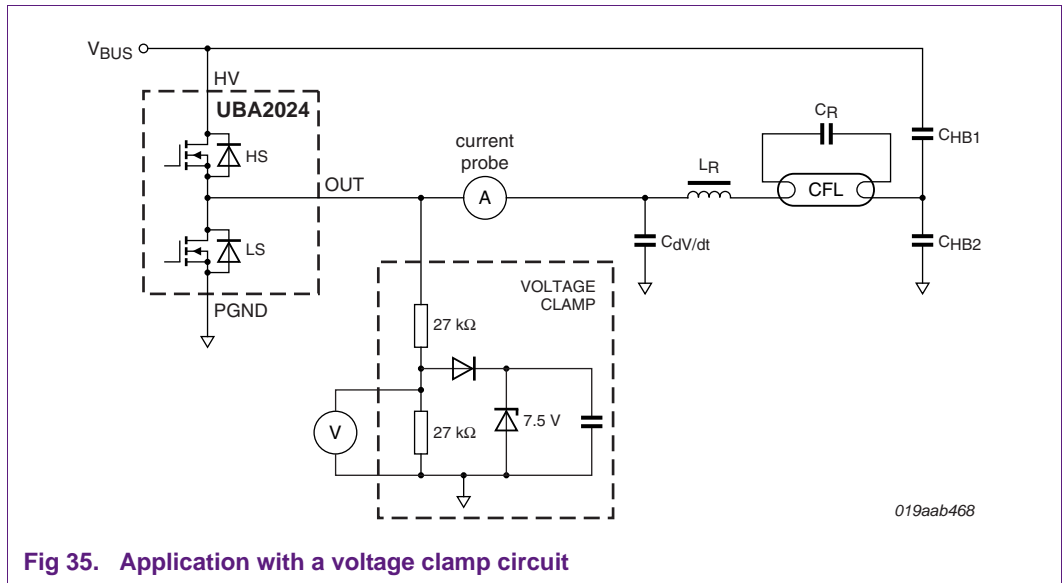

Fig 35. Application with a voltage clamp circuit

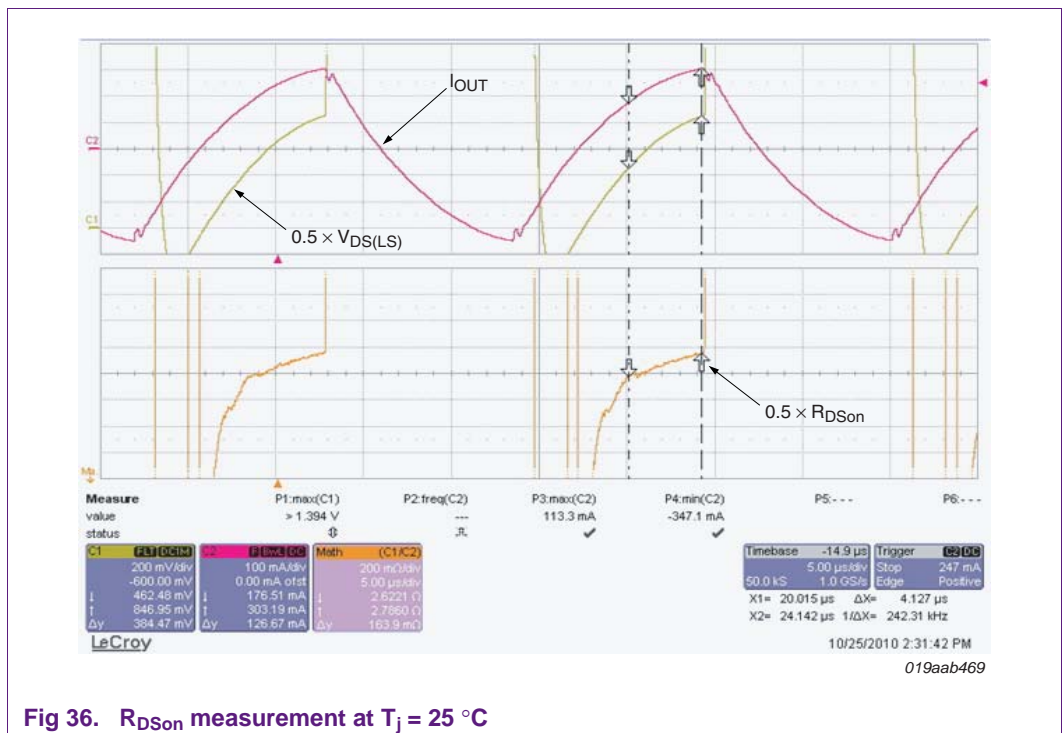

Fig 36. R_{DSon} measurement at T_j = 25 °C

The first measurement is performed immediately after the lamp has ignited where the package temperature is still equal to the ambient temperature of 25 °C. The junction temperature is supposed to be the same.

V_{DS} of the low-side MOSFET is measured by means of a voltage clamp as shown in [Figure 35](#). Actually $V_{DS}/2$ is measured, due to the 27 kΩ voltage divider in the clamp circuit. The current is measured through the OUT pin of the UBA2024. The actual R_{DSon} is determined by the ratio of V_{DS} and I_{OUT} . See [Figure 36](#) and [Figure 37](#).

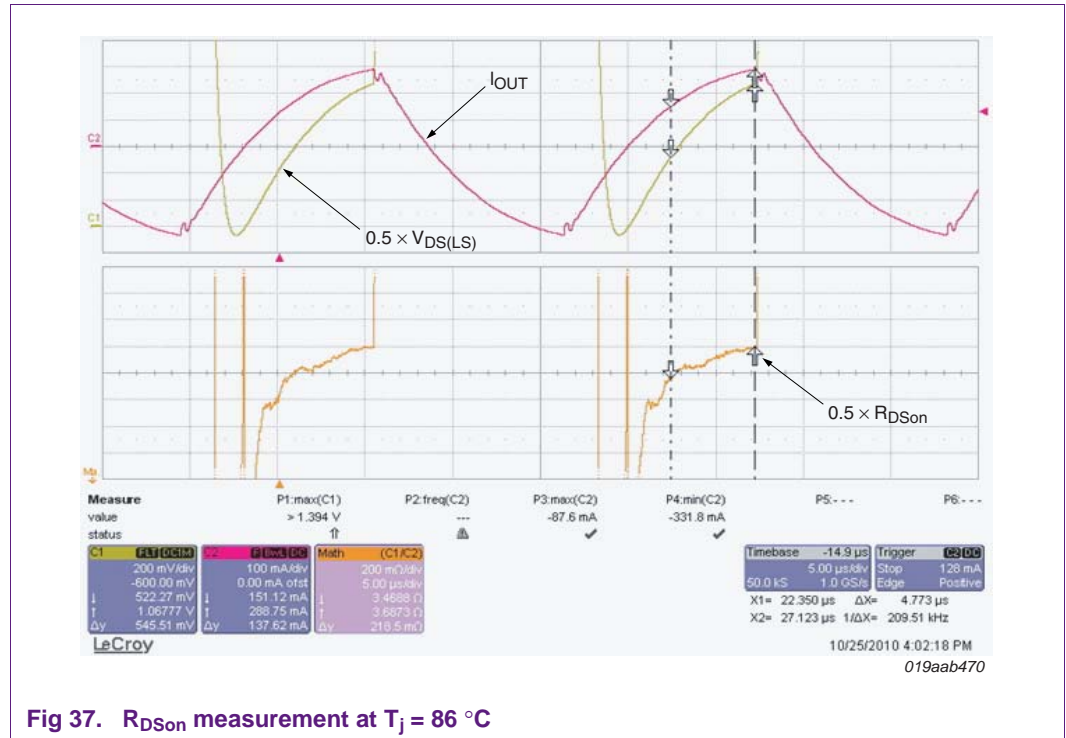

Fig 37. R_{DSon} measurement at $T_j = 86\text{ °C}$

The measurement results shown in [Figure 36](#) and [Figure 37](#) are for a UBA2024AP (DIP8) 18 W, 230 V application in a base down position. The measured values and corresponding calculations can be found in the Appendix in section 5.

12. Measurement results R_{DSon} and T_j calculations

In this section, the results and calculations are given for the R_{DSon} measurements and T_j calculations for an 18 W 230 V application with the UBA2024AP (DIP8) and UBA2024AT (SO14).

12.1 Measurement on a UBA2024AP (DIP8) 18 W 230 V application

The measured R_{DSon} at 25 °C equals 5.57 Ω , so at 150 °C the calculated maximum R_{DSon} is $1.7 \times 5.57 \Omega = 9.47 \Omega$ according to [Equation 7](#). The increase of resistance per °C equals $(9.47 - 5.57) / (150 - 25) = 31.22 \text{ m}\Omega/\text{°C}$, according to [Equation 6](#).

12.1.1 Operation in base down position

After an hour in operation in a base down position, the following data is measured: $T_{CASE} = 86 \text{ °C}$, $R_{DSon,operating} = 7.37 \Omega$, well below $R_{DSon,maximum}$. Now the junction temperature can be calculated, using [Equation 8](#).

$$T_j = 25 + \frac{7.37 - 5.57}{31.22 \cdot 10^{-3}} = 83 \text{ °C} \quad (9)$$

12.1.2 Operation in base up position

After an hour in operation in a base up position, the following data is measured: $T_{CASE} = 110 \text{ °C}$, $R_{DSon,operating} = 7.92 \Omega$, well below $R_{DSon,maximum}$. Now the junction temperature can be calculated, using [Equation 8](#).

$$T_j = 25 + \frac{7.92 - 5.57}{31.22 \cdot 10^{-3}} = 101 \text{ °C} \quad (10)$$

12.2 Measurement on a UBA2024AT (SO14) 18 W 230 V application

The measured R_{DSon} at 25 °C equals 6.34 Ω , so at 150 °C the calculated maximum R_{DSon} is $1.7 \times 6.34 \Omega = 10.77 \Omega$ according to [Equation 7](#). The increase of resistance per °C equals $(10.77 - 6.34) / (150 - 25) = 34.22 \text{ m}\Omega/\text{°C}$, according to [Equation 6](#).

12.2.1 Operation in base down position

After an hour in operation in a base down position, the following data is measured: $T_{CASE} = 89 \text{ °C}$, $R_{DSon,operating} = 9.04 \Omega$, well below $R_{DSon,maximum}$. Now the junction temperature can be calculated, using [Equation 8](#).

$$T_j = 25 + \frac{9.04 - 6.34}{35.45 \cdot 10^{-3}} = 101 \text{ °C} \quad (11)$$

12.2.2 Operation in base up position

After an hour in operation in a base up position, the following data is measured: $T_{CASE} = 111 \text{ °C}$, $R_{DSon,operating} = 9.24 \Omega$, well below $R_{DSon,maximum}$. Now the junction temperature can be calculated, using [Equation 8](#).

$$T_j = 25 + \frac{9.24 - 6.34}{35.45 \cdot 10^{-3}} = 107 \text{ °C} \quad (12)$$

13. References

- [1] **IEEE publication** — An Improved Design Procedure for LCC Resonant Filter of Dimmable Electronic.
- [2] **Ballasts for Fluorescent Lamps, Based on Lamp Model** — Fabio Toshiaki Wakabayashi Carlos Alberto Canesin 2003.

14. Legal information

14.1 Definitions

Draft — The document is a draft version only. The content is still under internal review and subject to formal approval, which may result in modifications or additions. NXP Semiconductors does not give any representations or warranties as to the accuracy or completeness of information included herein and shall have no liability for the consequences of use of such information.

14.2 Disclaimers

Limited warranty and liability — Information in this document is believed to be accurate and reliable. However, NXP Semiconductors does not give any representations or warranties, expressed or implied, as to the accuracy or completeness of such information and shall have no liability for the consequences of use of such information.

In no event shall NXP Semiconductors be liable for any indirect, incidental, punitive, special or consequential damages (including - without limitation - lost profits, lost savings, business interruption, costs related to the removal or replacement of any products or rework charges) whether or not such damages are based on tort (including negligence), warranty, breach of contract or any other legal theory.

Notwithstanding any damages that customer might incur for any reason whatsoever, NXP Semiconductors' aggregate and cumulative liability towards customer for the products described herein shall be limited in accordance with the *Terms and conditions of commercial sale* of NXP Semiconductors.

Right to make changes — NXP Semiconductors reserves the right to make changes to information published in this document, including without limitation specifications and product descriptions, at any time and without notice. This document supersedes and replaces all information supplied prior to the publication hereof.

Suitability for use — NXP Semiconductors products are not designed, authorized or warranted to be suitable for use in life support, life-critical or safety-critical systems or equipment, nor in applications where failure or malfunction of an NXP Semiconductors product can reasonably be expected to result in personal injury, death or severe property or environmental damage. NXP Semiconductors accepts no liability for inclusion and/or use of NXP Semiconductors products in such equipment or applications and therefore such inclusion and/or use is at the customer's own risk.

Applications — Applications that are described herein for any of these products are for illustrative purposes only. NXP Semiconductors makes no representation or warranty that such applications will be suitable for the specified use without further testing or modification.

Customers are responsible for the design and operation of their applications and products using NXP Semiconductors products, and NXP Semiconductors accepts no liability for any assistance with applications or customer product design. It is customer's sole responsibility to determine whether the NXP Semiconductors product is suitable and fit for the customer's applications and products planned, as well as for the planned application and use of customer's third party customer(s). Customers should provide appropriate design and operating safeguards to minimize the risks associated with their applications and products.

NXP Semiconductors does not accept any liability related to any default, damage, costs or problem which is based on any weakness or default in the customer's applications or products, or the application or use by customer's third party customer(s). Customer is responsible for doing all necessary testing for the customer's applications and products using NXP Semiconductors products in order to avoid a default of the applications and the products or of the application or use by customer's third party customer(s). NXP does not accept any liability in this respect.

Evaluation products — This product is provided on an "as is" and "with all faults" basis for evaluation purposes only. NXP Semiconductors, its affiliates and their suppliers expressly disclaim all warranties, whether express, implied or statutory, including but not limited to the implied warranties of non-infringement, merchantability and fitness for a particular purpose. The entire risk as to the quality, or arising out of the use or performance, of this product remains with customer.

In no event shall NXP Semiconductors, its affiliates or their suppliers be liable to customer for any special, indirect, consequential, punitive or incidental damages (including without limitation damages for loss of business, business interruption, loss of use, loss of data or information, and the like) arising out of the use of or inability to use the product, whether or not based on tort (including negligence), strict liability, breach of contract, breach of warranty or any other theory, even if advised of the possibility of such damages.

Notwithstanding any damages that customer might incur for any reason whatsoever (including without limitation, all damages referenced above and all direct or general damages), the entire liability of NXP Semiconductors, its affiliates and their suppliers and customer's exclusive remedy for all of the foregoing shall be limited to actual damages incurred by customer based on reasonable reliance up to the greater of the amount actually paid by customer for the product or five dollars (US\$5.00). The foregoing limitations, exclusions and disclaimers shall apply to the maximum extent permitted by applicable law, even if any remedy fails of its essential purpose.

Export control — This document as well as the item(s) described herein may be subject to export control regulations. Export might require a prior authorization from national authorities.

Safety of high-voltage evaluation products — The non-insulated high voltages that are present when operating this product, constitute a risk of electric shock, personal injury, death and/or ignition of fire. This product is intended for evaluation purposes only. It shall be operated in a designated test area by personnel that is qualified according to local requirements and labor laws to work with non-insulated mains voltages and high-voltage circuits.

The product does not comply with IEC 60950 based national or regional safety standards. NXP Semiconductors does not accept any liability for damages incurred due to inappropriate use of this product or related to non-insulated high voltages. Any use of this product is at customer's own risk and liability. The customer shall fully indemnify and hold harmless NXP Semiconductors from any liability, damages and claims resulting from the use of the product.

14.3 Trademarks

Notice: All referenced brands, product names, service names and trademarks are the property of their respective owners.

15. Contents

1	Introduction	3	12.2	Measurement on a UBA2024AT (SO14) 18 W 230 V application	40
1.1	Features	3	12.2.1	Operation in base down position	40
1.2	System benefits	3	12.2.2	Operation in base up position	40
2	Circuit diagram	4	13	References	41
3	Design of an 18 W non-dimmable CFL	5	14	Legal information	42
3.1	Selecting input configuration, buffer capacitor and fused resistor	5	14.1	Definitions	42
3.2	Choosing frequency, lamp inductor and capacitor	5	14.2	Disclaimers	42
3.2.1	Input values	5	14.3	Trademarks	42
3.2.2	Calculation plots	9	15	Contents	43
3.2.3	Coil	11			
3.2.4	Thermal properties	12			
3.2.5	Literature reference	12			
3.3	Operating frequency	12			
3.4	Ignition frequency and quasi-preheating	13			
3.5	Choosing the other components	14			
3.6	About component tolerances	14			
4	Quick measurements	15			
5	Start-up and stop waveforms	15			
6	Layout considerations	16			
7	Application examples	16			
7.1	Reference board	16			
7.1.1	External lamp detection circuit	16			
7.2	UBA2024 with additional feed-forward circuit	21			
7.2.1	Introduction	21			
7.2.2	Implementation	21			
7.3	Driving a CCFL lamp with the UBA2024	22			
7.4	UBA2024 in a replaceable lamp configuration (matchbox ballast)	23			
8	Improved preheat	26			
8.1	Start-up of an application with the new preheat circuit	27			
9	Lamp glow	28			
10	Coil saturation	30			
11	Thermal behavior	36			
11.1	Junction temperature measurements	37			
11.2	R_{DSon} measurements in the CFL application	38			
12	Measurement results R_{DSon} and T_j calculations	40			
12.1	Measurement on a UBA2024AP (DIP8) 18 W 230 V application	40			
12.1.1	Operation in base down position	40			
12.1.2	Operation in base up position	40			

Please be aware that important notices concerning this document and the product(s) described herein, have been included in section 'Legal information'.

© NXP B.V. 2011.

All rights reserved.

For more information, please visit: <http://www.nxp.com>

For sales office addresses, please send an email to: salesaddresses@nxp.com

Date of release: 11 February 2011

Document identifier: AN10713

X-ON Electronics

Largest Supplier of Electrical and Electronic Components

Click to view similar products for [nxp](#) manufacturer:

Other Similar products are found below :

[MC13211R2](#) [PCA9518PW,112](#) [LFSTBEB865X](#) [MC33399PEFR2](#) [PCA9551PW,112](#) [MC34825EPR2](#) [PCF8583P](#) [MC68340AB16E](#)
[MC8640DTVJ1250HE](#) [EVBCRTOUCH](#) [MC9S08PT16AVLC](#) [MC9S08PT8AVTG](#) [MC9S08SH32CTL](#) [MCF54415CMJ250](#) [MCIMX6Q-SDB](#)
[MCIMX6SX-SDB](#) [74ALVC125BQ,115](#) [74HC4050N](#) [74HC4514N](#) [MK21FN1M0AVLQ12](#) [MKV30F128VFM10](#) [FRDM-K66F](#) [FRDM-](#)
[KW40Z](#) [FRDM-MC-LVBLDC](#) [PESD18VF1BSFYL](#) [PMF63UNEX](#) [PSMN4R0-60YS,115](#) [HEF4028BPN](#) [RAPPID-567XFSW](#)
[MPC565MVR56](#) [MPC574XG-176DS](#) [MPC860PCVR66D4](#) [BT137-600E](#) [BT139X-600.127](#) [BUK7628-100A118](#) [BUK765R0-100E.118](#)
[BZT52H-B9V1.115](#) [BZV85-C3V9.113](#) [BZX79-C47.113](#) [P5020NSE7VNB](#) [S12ZVML12EVBLIN](#) [SCC2692AC1N40](#) [LPC1785FBD208K](#)
[LPC2124FBD64/01](#) [LS1020ASN7KQB](#) [LS1020AXN7HNB](#) [LS1020AXN7KQB](#) [LS1043ASE7PQA](#) [T1023RDB-PC](#) [FRDM-KW24D512](#)