

# CBTL04GP043

## Dual 2 x 2 differential channel crossbar switch

Rev. 1.1 — 27 July 2015

Product data sheet

## 1. General description

The CBTL04GP043 is a high-performance 4-channel bidirectional crossbar switch supporting both high speed and large swing signals. The high-speed differential signals include PCIe-Gen3, USB3 and DisplayPort. The large swing signals include UART, USB 2.0 and HDMI 1.4 signals.

This chip can be configured as pair straight through or cross to the output ports through the CROSS signal. It can be placed under Low-power mode using the XSDN pin.

This crossbar switch supports wide common-mode voltage range from 0 V to  $V_{DD}$  on all input and output ports.

CBTL04GP043 is available in 2.00 mm × 4.00 mm × 0.5 mm XFBGA28 package with 0.5 mm pitch.

## 2. Features and benefits

- 4-channel, bidirectional crossbar switch
- The input of the CROSS pin
  - ◆ CROSS is LOW for connecting input and output ports straight through
  - ◆ CROSS is HIGH for crossbar connection between input and output ports
- When XSDN is LOW, the switch is in low-power sleep mode
- Low ON-state resistance: 11  $\Omega$  (typical)
- Bandwidth: 8.5 GHz (typical) for  $V_{IC} = 2.2$  V
- Low insertion loss: -1.5 dB at 2.5 GHz; -1 dB at 100 MHz
- Low return loss: -20 dB at 2.5 GHz
- Low off-state isolation: -16 dB at 2.5 GHz; -40 dB at 100 MHz
- Low DDNEXT crosstalk: -20 dB at 2.5 GHz
- $V_{IC}$  common-mode input voltage  $V_{IC}$ : 0 V to  $V_{DD}$
- Differential input voltage  $V_{ID}$ : 1.4 V (maximum)
- Intra-pair skew: 5 ps (typical)
- Supports power supply voltage range from 2.7 V to 3.5 V
- Back current protection on all I/O pins of these switches
- All channels support rail-to-rail input voltage
- XFBGA28 2 mm × 4 mm × 0.5 mm package with 0.5 mm pitch
- ESD: 2000 V HBM; 750 V CDM
- Operating temperature range: -20 °C to +85 °C



### 3. Ordering information

Table 1. Ordering information

Type number	Topside marking	Package		Version
		Name	Description	
CBTL04GP043EX	GP43* <a href="#">[1]</a>	XFBGA28	plastic, extremely thin fine-pitch ball grid array package; 28 balls; body 2.00 × 4.00 × 0.5 mm; 0.5 mm pitch	SOT1356-1

[1] \*\* changes based on date code.

#### 3.1 Ordering options

Table 2. Ordering options

Type number	Orderable part number	Package	Packing method	Minimum order quantity	Temperature
CBTL04GP043EX	CBTL04GP043EXJ	XFBGA28	Reel 13" Q1/T1 *standard mark SMD	7000	T <sub>amb</sub> = -20 °C to +85 °C

### 4. Block diagram

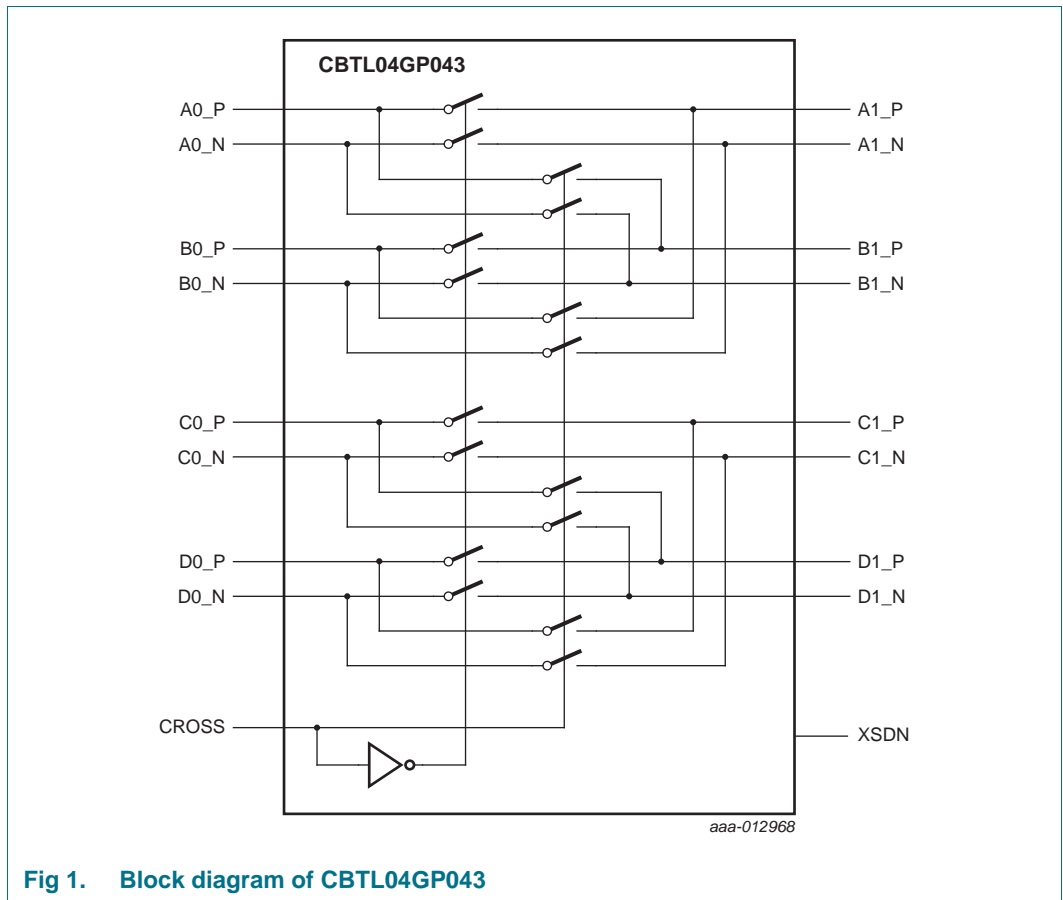
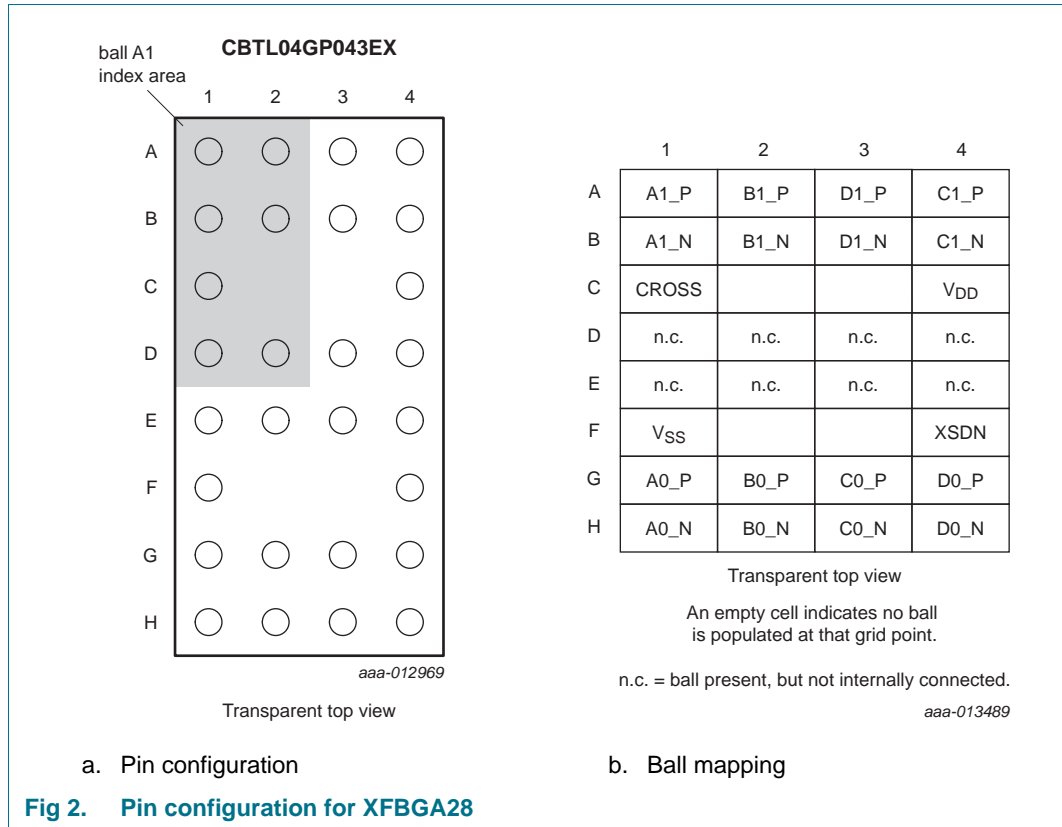

Fig 1. Block diagram of CBTL04GP043

## 5. Pinning information

### 5.1 Pinning



## 5.2 Pin description

Table 3. Pin description

Symbol	Pin	Type	Description
<b>Data path signals</b>			
A1_P	A1	I/O	Port A1
A1_N	B1	I/O	
B1_P	A2	I/O	Port B1
B1_N	B2	I/O	
C1_P	A4	I/O	Port C1
C1_N	B4	I/O	
D1_P	A3	I/O	Port D1
D1_N	B3	I/O	
A0_P	G1	I/O	Port A0
A0_N	H1	I/O	
B0_P	G2	I/O	Port B0
B0_N	H2	I/O	
C0_P	G3	I/O	Port C0
C0_N	H3	I/O	
D0_P	G4	I/O	Port D0
D0_N	H4	I/O	
<b>Control signals</b>			
CROSS	C1	CMOS input	When CROSS = HIGH, selects cross function. When CROSS = LOW, selects pass-through function. CROSS input must be LOW for more than 500 $\mu$ s during start up time.
XSDN	F4	CMOS input	When XSDN = HIGH, enables XBAR switches. When XSDN = LOW, all switches are 3-stated.
<b>Power supply</b>			
V <sub>DD</sub>	C4	power	Power supply range from 3.0 V to 3.5 V.
<b>Ground connection</b>			
V <sub>SS</sub>	F1	ground	Supply ground (0 V).
n.c.	D1, D2, D3, D4, E1, E2, E3, E4	-	Not connected. These balls should be connected to solid ground plane on PCB to improve signal integrity.

## 6. Functional description

Refer to [Figure 1 “Block diagram of CBTL04GP043”](#).

When CROSS input is LOW, Port 0 pins are connected to their respective Port 1 pins.  
 When CROSS input is HIGH, Port 0 A and B are crossed to Port 1 B and A,  
 Port 0 C and D are crossed to Port 1 D and C.

When XSDN input is HIGH, the crossbar switch is in normal operation mode. When XSDN input is LOW, the crossbar switch is placed under high-impedance state.

**Table 4. Function table**

Port 1 connected to Port 0	XSDN = 0	XSDN = 1, CROSS = 0	XSDN = 1, CROSS = 1
A1_P	high-Z	A0_P	B0_P
A1_N	high-Z	A0_N	B0_N
B1_P	high-Z	B0_P	A0_P
B1_N	high-Z	B0_N	A0_N
C1_P	high-Z	C0_P	D0_P
C1_N	high-Z	C0_N	D0_N
D1_P	high-Z	D0_P	C0_P
D1_N	high-Z	D0_N	C0_N

## 7. Power-up sequence

The CROSS pin must be LOW before start-up time has elapsed. After both V<sub>DD</sub> and XSDN go HIGH for 500 μs (t<sub>startup</sub> time), CROSS input can be toggled to HIGH.

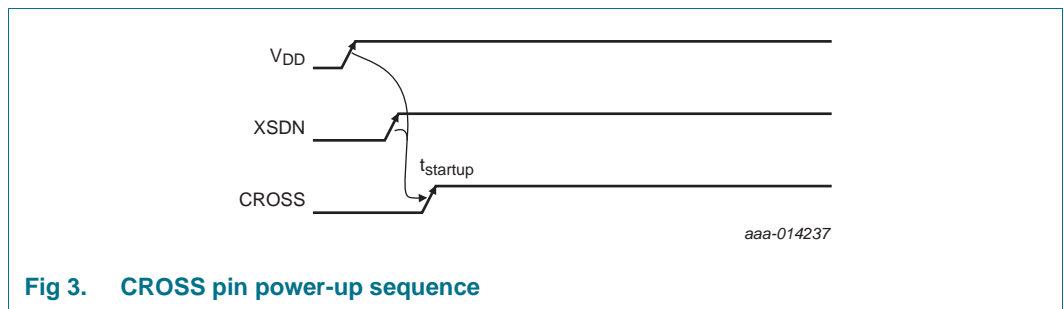

## 8. Limiting values

**Table 5. Limiting values**

In accordance with the Absolute Maximum Rating System (IEC 60134).

Symbol	Parameter	Conditions	Min	Max	Unit	
V <sub>DD</sub>	supply voltage	[1]	-0.3	+4.6	V	
V <sub>I</sub>	input voltage	control pins	[1]	-0.3	+5.5	V
		I/O pins of switches	[1]	-0.3	+4.6	V
T <sub>stg</sub>	storage temperature		-65	+150	°C	
V <sub>ESD</sub>	electrostatic discharge voltage	HBM	[2]	-	2000	V
		CDM	[3]	-	750	V

[1] All voltage values, except differential voltages, are with respect to network ground terminal.

[2] Human Body Model: ANSI/ESDA/JEDEC JDS-001-2012 (Revision of ANSI/ESDA/JEDEC JS-001-2011), ESDA/JEDEC Joint standard for ESD sensitivity testing, Human Body Model - Component level; Electrostatic Discharge Association, Rome, NY, USA; JEDEC Solid State Technology Association, Arlington, VA, USA.

[3] Charged Device Model; JESD22-C101E December 2009 (Revision of JESD22-C101D, October 2008), standard for ESD sensitivity testing, Charged Device Model - Component level; JEDEC Solid State Technology Association, Arlington, VA, USA.

## 9. Recommended operating conditions

**Table 6. Operating conditions**

Over operating free-air temperature range (unless otherwise noted).

Symbol	Parameter	Conditions	Min	Typ	Max	Unit
V <sub>DD</sub>	supply voltage	3.3 V supply option	2.7	-	3.5	V
V <sub>I</sub>	input voltage	CMOS inputs	-0.3	-	+5.5	V
		MUX I/O pins	-0.3	-	+3.5	V
T <sub>amb</sub>	ambient temperature	operating in free air	-20	-	+85	°C
R <sub>th(j-a)</sub>	thermal resistance from junction to ambient	JEDEC still air test environment	-	149	-	°C/W
R <sub>th(j-c)</sub>	thermal resistance from junction to case	to case top; top cold plate at ambient temperature of 85 °C	-	69	-	°C/W

## 10. Characteristics

### 10.1 Device general characteristics

Table 7. General characteristics

Symbol	Parameter	Conditions	Min	Typ	Max	Unit
$P_{\text{cons}}$	power consumption	$V_{\text{DD}} = 3.5 \text{ V}$	-	-	1.75	mW
$P_{\text{cons(sleep)}}$	sleep mode power consumption	XSDN = 0	-	-	42	$\mu\text{W}$
$I_{\text{DD}}$	supply current	$V_{\text{DD}} = 3.5 \text{ V}$	-	-	0.5	mA
$t_{\text{startup}}$	start-up time	supply voltage valid and XSDN goes HIGH to channel-specified operating characteristics	-	-	500	$\mu\text{s}$
$t_{\text{rcfg}}$	reconfiguration time	CROSS pin	-	300	1000	$\mu\text{s}$

### 10.2 Switch channel characteristics

Table 8. Dynamic and static characteristics

Symbol	Parameter	Conditions	Min	Typ	Max	Unit
DDRL	differential return loss	$f = 2.5 \text{ GHz}$	-	-20	-	dB
DDIL	differential insertion loss	channel is OFF				
		$f = 2.5 \text{ GHz}$	-	-16	-	dB
		$f = 100 \text{ MHz}$	-	-40	-	dB
		channel is ON				
		$f = 2.5 \text{ GHz}$	-	-1.5	-	dB
		$f = 100 \text{ MHz}$	-	-1	-	dB
DDNEXT	differential near-end crosstalk	channels among Port 0 or channels among Port 1				
		$f = 2.5 \text{ GHz}$	-	-20	-	dB
		$f = 240 \text{ MHz}$	-	-44	-	dB
DDFEXT	differential far-end crosstalk	between channels of Port 0 and Port 1				
		$f = 2.5 \text{ GHz}$	-	-23	-	dB
		$f = 240 \text{ MHz}$	-	-53	-	dB
$R_{\text{on}}$	ON-state resistance	$V_{\text{DD}} = 2.7 \text{ V}; V_{\text{I}} = 2.2 \text{ V}; I_{\text{I}} = 10 \text{ mA}$	-	11	15	$\Omega$
$C_{\text{in}}$	input capacitance	single-ended; $V_{\text{DD}} = 2.8 \text{ V}; V_{\text{I}} = 2.2 \text{ V}$	-	3	-	pF
$B_{-3\text{dB}}$	-3 dB bandwidth	$V_{\text{IC}} = 0 \text{ V}$	-	7	-	GHz
		$V_{\text{IC}} = 2.2 \text{ V}$	-	8.5	-	GHz
$t_{\text{PD}}$	propagation delay	from input to output pairs	-	70	-	ps
$t_{\text{sk(dif)}}$	differential skew time	intra-pair	-	5	-	ps
$V_{\text{I}}$	input voltage	for all switch ports	0	-	3.5	V
$V_{\text{IC}}$	common-mode input voltage	for all switch ports	0	-	$V_{\text{DD}}$	V
$V_{\text{I(dif)(p-p)}}$	peak-to-peak differential input voltage	for all switch ports	0	-	1.4	V
$I_{\text{LIH}}$	HIGH-level input leakage current	$V_{\text{DD}} = \text{max.}; V_{\text{I}} = V_{\text{DD}}$	-	-	$\pm 1$	$\mu\text{A}$
$I_{\text{LIL}}$	LOW-level input leakage current	$V_{\text{DD}} = \text{max.}; V_{\text{I}} = V_{\text{SS}}$	-	-	$\pm 1$	$\mu\text{A}$

### 10.3 Control signals characteristics

**Table 9. CROSS input buffer characteristics**

Symbol	Parameter	Conditions	Min	Typ	Max	Unit
$V_{IH}$	HIGH-level input voltage	CMOS input	2.15	-	-	V
$V_{IL}$	LOW-level input voltage	CMOS input	-	-	0.5	V
$I_{LI}$	input leakage current	measured with input at $V_{IH} = V_{DD}$ and $V_{IL} = 0$ V	[1]	-	0.2	$\mu$ A

[1] This  $I_{LI}$  value is guaranteed by design and bench test.

**Table 10. XSDN input buffer characteristics**

Symbol	Parameter	Conditions	Min	Typ	Max	Unit
$V_{IH}$	HIGH-level input voltage	CMOS inputs	2.15	-	-	V
$V_{IL}$	LOW-level input voltage	CMOS inputs	-	-	0.5	V
$I_{LI}$	input leakage current	measured with input at $V_{IH} = V_{DD}$ and $V_{IL} = 0$ V	-	-	1	$\mu$ A



11. Package outline

XFBGA28: plastic, extremely thin fine-pitch ball grid array package; 28 balls

SOT1356-1

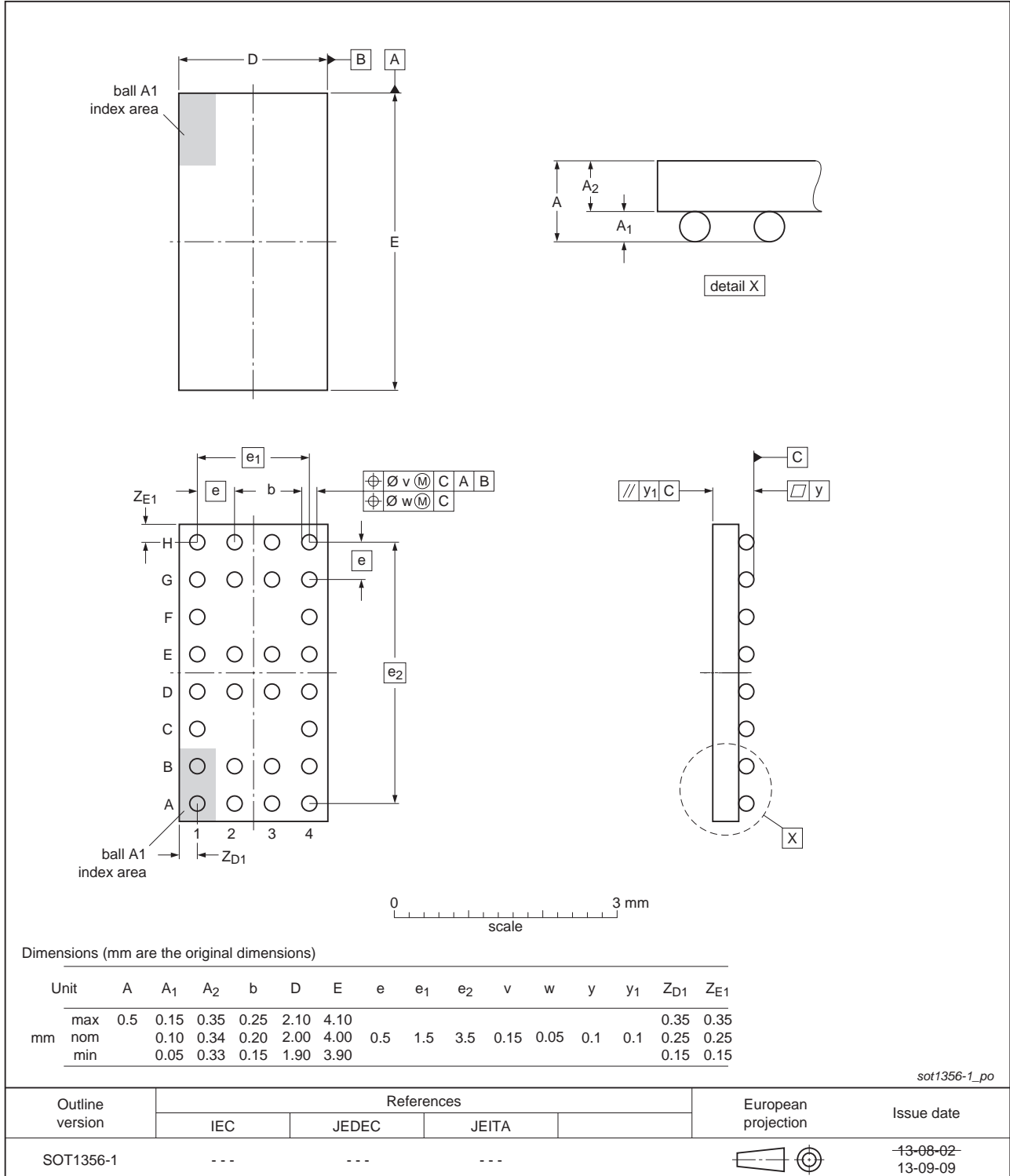

Fig 4. Package outline SOT1356-1 (XFBGA28)

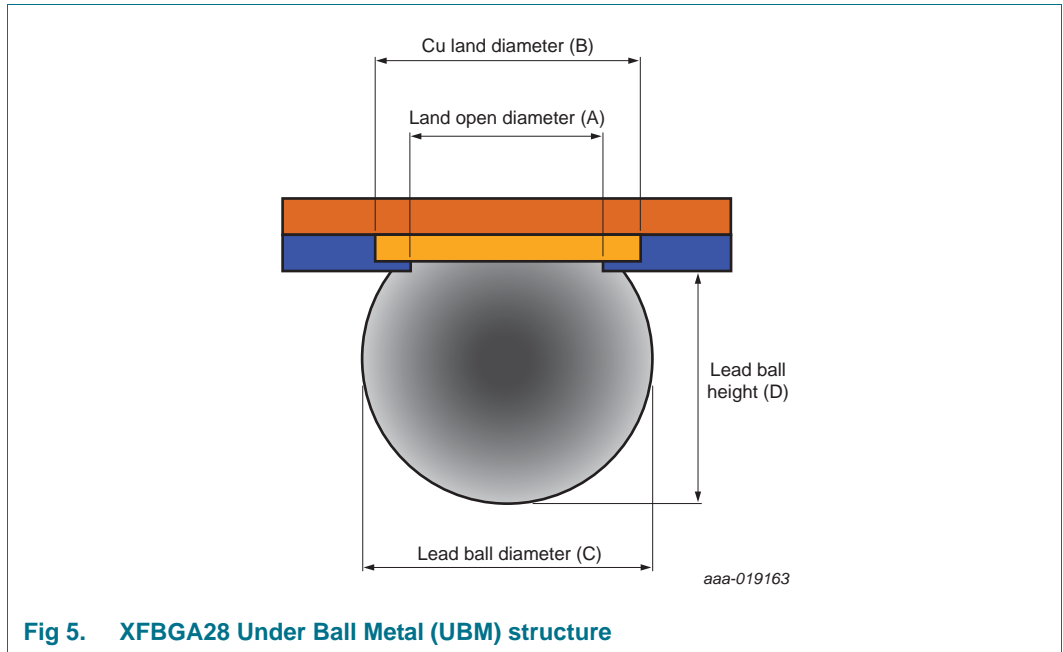
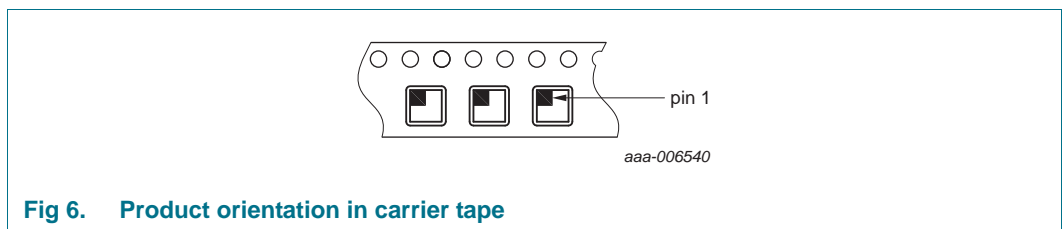

Table 11. For 2 x 4 mm HLA AEX device

Ball pitch (mm)	Land open diameter (A) (mm)	Cu land diameter (B) (mm)	Lead ball diameter (C) (mm)	Lead ball height (D) (mm)
0.5	0.18 ± 0.013	0.25 ± 0.05	0.2 ± 0.05	0.1 ± 0.05

## 12. Packing information



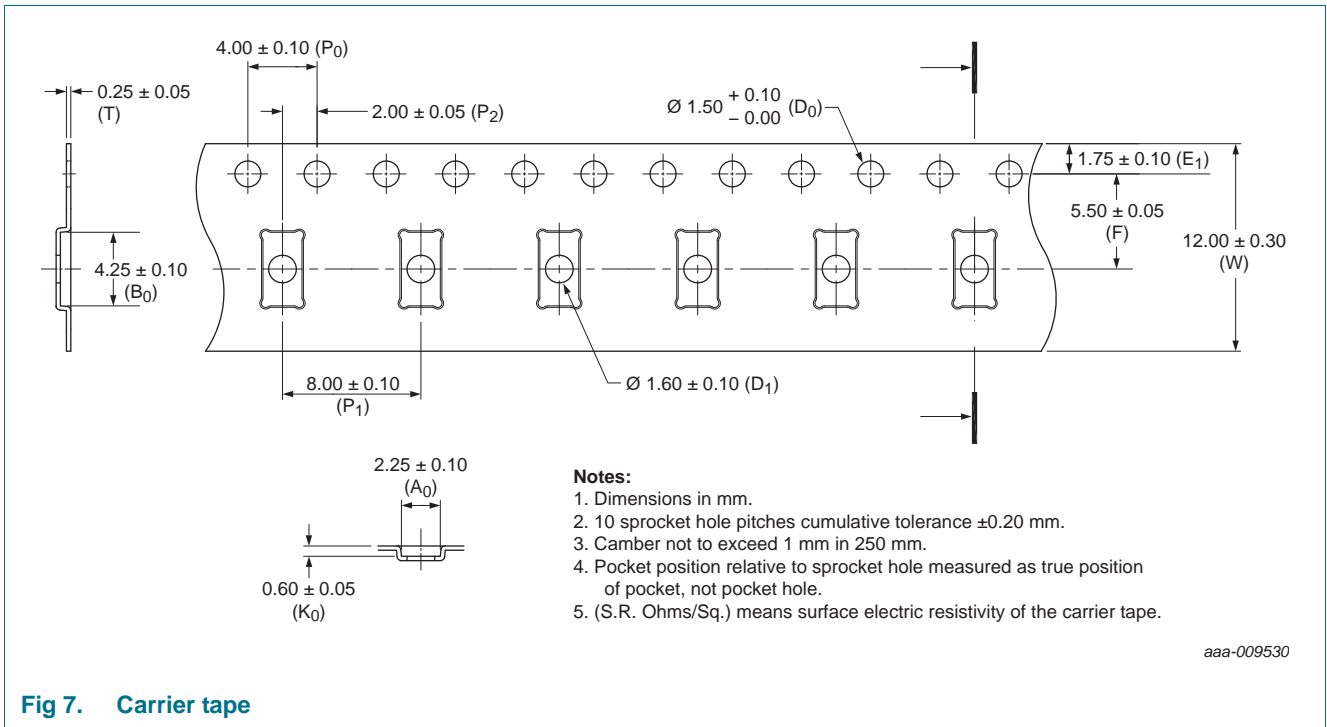

Fig 7. Carrier tape

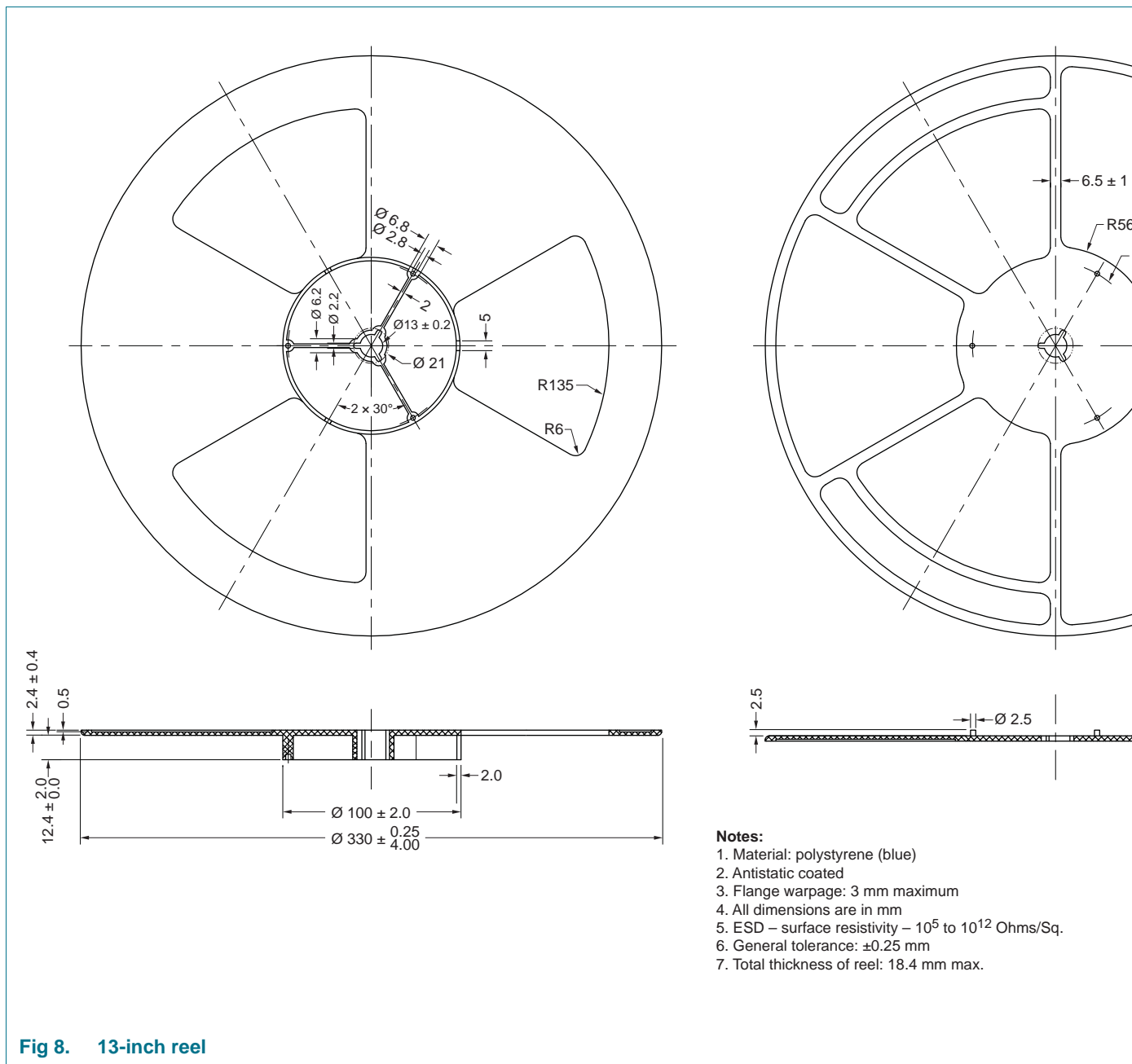
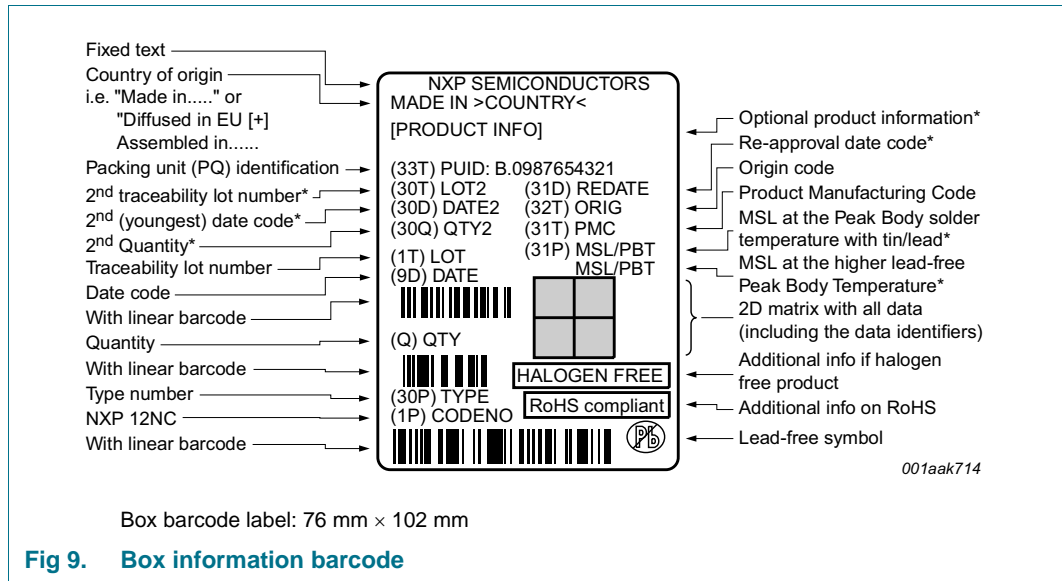

Fig 8. 13-inch reel



### 13. Soldering of SMD packages

This text provides a very brief insight into a complex technology. A more in-depth account of soldering ICs can be found in Application Note AN10365 "Surface mount reflow soldering description".

#### 13.1 Introduction to soldering

Soldering is one of the most common methods through which packages are attached to Printed Circuit Boards (PCBs), to form electrical circuits. The soldered joint provides both the mechanical and the electrical connection. There is no single soldering method that is ideal for all IC packages. Wave soldering is often preferred when through-hole and Surface Mount Devices (SMDs) are mixed on one printed wiring board; however, it is not suitable for fine pitch SMDs. Reflow soldering is ideal for the small pitches and high densities that come with increased miniaturization.

#### 13.2 Wave and reflow soldering

Wave soldering is a joining technology in which the joints are made by solder coming from a standing wave of liquid solder. The wave soldering process is suitable for the following:

- Through-hole components
- Leaded or leadless SMDs, which are glued to the surface of the printed circuit board

Not all SMDs can be wave soldered. Packages with solder balls, and some leadless packages which have solder lands underneath the body, cannot be wave soldered. Also, leaded SMDs with leads having a pitch smaller than ~0.6 mm cannot be wave soldered, due to an increased probability of bridging.

The reflow soldering process involves applying solder paste to a board, followed by component placement and exposure to a temperature profile. Leaded packages, packages with solder balls, and leadless packages are all reflow solderable.

Key characteristics in both wave and reflow soldering are:

- Board specifications, including the board finish, solder masks and vias
- Package footprints, including solder thieves and orientation
- The moisture sensitivity level of the packages
- Package placement
- Inspection and repair
- Lead-free soldering versus SnPb soldering

### 13.3 Wave soldering

Key characteristics in wave soldering are:

- Process issues, such as application of adhesive and flux, clinching of leads, board transport, the solder wave parameters, and the time during which components are exposed to the wave
- Solder bath specifications, including temperature and impurities

### 13.4 Reflow soldering

Key characteristics in reflow soldering are:

- Lead-free versus SnPb soldering; note that a lead-free reflow process usually leads to higher minimum peak temperatures (see [Figure 10](#)) than a SnPb process, thus reducing the process window
- Solder paste printing issues including smearing, release, and adjusting the process window for a mix of large and small components on one board
- Reflow temperature profile; this profile includes preheat, reflow (in which the board is heated to the peak temperature) and cooling down. It is imperative that the peak temperature is high enough for the solder to make reliable solder joints (a solder paste characteristic). In addition, the peak temperature must be low enough that the packages and/or boards are not damaged. The peak temperature of the package depends on package thickness and volume and is classified in accordance with [Table 12](#) and [13](#)

**Table 12. SnPb eutectic process (from J-STD-020D)**

Package thickness (mm)	Package reflow temperature (°C)	
	Volume (mm <sup>3</sup> )	
	< 350	≥ 350
< 2.5	235	220
≥ 2.5	220	220

**Table 13. Lead-free process (from J-STD-020D)**

Package thickness (mm)	Package reflow temperature (°C)		
	Volume (mm <sup>3</sup> )		
	< 350	350 to 2000	> 2000
< 1.6	260	260	260
1.6 to 2.5	260	250	245
> 2.5	250	245	245

Moisture sensitivity precautions, as indicated on the packing, must be respected at all times.

Studies have shown that small packages reach higher temperatures during reflow soldering, see [Figure 10](#).

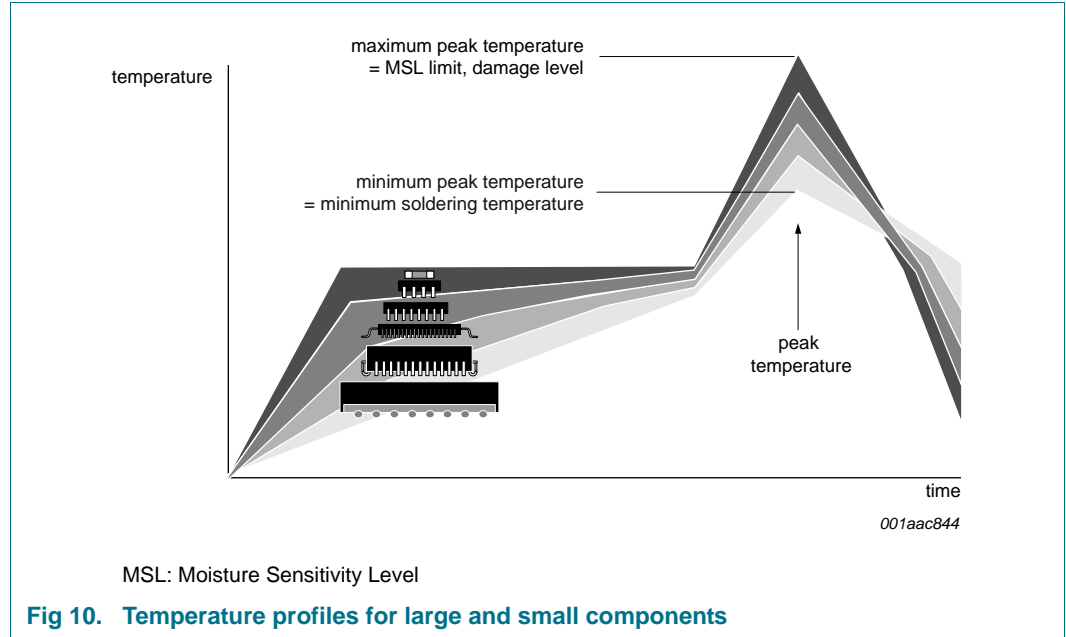

For further information on temperature profiles, refer to Application Note *AN10365* “Surface mount reflow soldering description”.

## 14. Abbreviations

**Table 14. Abbreviations**

Acronym	Description
CDM	Charged-Device Model
CMOS	Complementary Metal-Oxide Semiconductor
ESD	ElectroStatic Discharge
HBM	Human Body Model
MUX	Multiplexer
POR	Power-On Reset
UART	Universal Asynchronous Receiver/Transmitter
USB	Universal Serial Bus

## 15. Revision history

Table 15. Revision history

Document ID	Release date	Data sheet status	Change notice	Supersedes
CBTL04043A1 v.1.1	20150727	Product data sheet	-	CBTL04043A1 v.1
Modifications:	<ul style="list-style-type: none"><li>Added <a href="#">Figure 5 “XFBGA28 Under Ball Metal (UBM) structure”</a> and <a href="#">Table 11 “For 2 x 4 mm HLA AEX device”</a>.</li></ul>			
CBTL04GP043 v.1	20141024	Product data sheet	-	-



## 16. Legal information

### 16.1 Data sheet status

Document status <sup>[1][2]</sup>	Product status <sup>[3]</sup>	Definition
Objective [short] data sheet	Development	This document contains data from the objective specification for product development.
Preliminary [short] data sheet	Qualification	This document contains data from the preliminary specification.
Product [short] data sheet	Production	This document contains the product specification.

[1] Please consult the most recently issued document before initiating or completing a design.

[2] The term 'short data sheet' is explained in section "Definitions".

[3] The product status of device(s) described in this document may have changed since this document was published and may differ in case of multiple devices. The latest product status information is available on the Internet at URL <http://www.nxp.com>.

### 16.2 Definitions

**Draft** — The document is a draft version only. The content is still under internal review and subject to formal approval, which may result in modifications or additions. NXP Semiconductors does not give any representations or warranties as to the accuracy or completeness of information included herein and shall have no liability for the consequences of use of such information.

**Short data sheet** — A short data sheet is an extract from a full data sheet with the same product type number(s) and title. A short data sheet is intended for quick reference only and should not be relied upon to contain detailed and full information. For detailed and full information see the relevant full data sheet, which is available on request via the local NXP Semiconductors sales office. In case of any inconsistency or conflict with the short data sheet, the full data sheet shall prevail.

**Product specification** — The information and data provided in a Product data sheet shall define the specification of the product as agreed between NXP Semiconductors and its customer, unless NXP Semiconductors and customer have explicitly agreed otherwise in writing. In no event however, shall an agreement be valid in which the NXP Semiconductors product is deemed to offer functions and qualities beyond those described in the Product data sheet.

### 16.3 Disclaimers

**Limited warranty and liability** — Information in this document is believed to be accurate and reliable. However, NXP Semiconductors does not give any representations or warranties, expressed or implied, as to the accuracy or completeness of such information and shall have no liability for the consequences of use of such information. NXP Semiconductors takes no responsibility for the content in this document if provided by an information source outside of NXP Semiconductors.

In no event shall NXP Semiconductors be liable for any indirect, incidental, punitive, special or consequential damages (including - without limitation - lost profits, lost savings, business interruption, costs related to the removal or replacement of any products or rework charges) whether or not such damages are based on tort (including negligence), warranty, breach of contract or any other legal theory.

Notwithstanding any damages that customer might incur for any reason whatsoever, NXP Semiconductors' aggregate and cumulative liability towards customer for the products described herein shall be limited in accordance with the *Terms and conditions of commercial sale* of NXP Semiconductors.

**Right to make changes** — NXP Semiconductors reserves the right to make changes to information published in this document, including without limitation specifications and product descriptions, at any time and without notice. This document supersedes and replaces all information supplied prior to the publication hereof.

**Suitability for use** — NXP Semiconductors products are not designed, authorized or warranted to be suitable for use in life support, life-critical or safety-critical systems or equipment, nor in applications where failure or malfunction of an NXP Semiconductors product can reasonably be expected to result in personal injury, death or severe property or environmental damage. NXP Semiconductors and its suppliers accept no liability for inclusion and/or use of NXP Semiconductors products in such equipment or applications and therefore such inclusion and/or use is at the customer's own risk.

**Applications** — Applications that are described herein for any of these products are for illustrative purposes only. NXP Semiconductors makes no representation or warranty that such applications will be suitable for the specified use without further testing or modification.

Customers are responsible for the design and operation of their applications and products using NXP Semiconductors products, and NXP Semiconductors accepts no liability for any assistance with applications or customer product design. It is customer's sole responsibility to determine whether the NXP Semiconductors product is suitable and fit for the customer's applications and products planned, as well as for the planned application and use of customer's third party customer(s). Customers should provide appropriate design and operating safeguards to minimize the risks associated with their applications and products.

NXP Semiconductors does not accept any liability related to any default, damage, costs or problem which is based on any weakness or default in the customer's applications or products, or the application or use by customer's third party customer(s). Customer is responsible for doing all necessary testing for the customer's applications and products using NXP Semiconductors products in order to avoid a default of the applications and the products or of the application or use by customer's third party customer(s). NXP does not accept any liability in this respect.

**Limiting values** — Stress above one or more limiting values (as defined in the Absolute Maximum Ratings System of IEC 60134) will cause permanent damage to the device. Limiting values are stress ratings only and (proper) operation of the device at these or any other conditions above those given in the Recommended operating conditions section (if present) or the Characteristics sections of this document is not warranted. Constant or repeated exposure to limiting values will permanently and irreversibly affect the quality and reliability of the device.

**Terms and conditions of commercial sale** — NXP Semiconductors products are sold subject to the general terms and conditions of commercial sale, as published at <http://www.nxp.com/profile/terms>, unless otherwise agreed in a valid written individual agreement. In case an individual agreement is concluded only the terms and conditions of the respective agreement shall apply. NXP Semiconductors hereby expressly objects to applying the customer's general terms and conditions with regard to the purchase of NXP Semiconductors products by customer.

**No offer to sell or license** — Nothing in this document may be interpreted or construed as an offer to sell products that is open for acceptance or the grant, conveyance or implication of any license under any copyrights, patents or other industrial or intellectual property rights.

**Export control** — This document as well as the item(s) described herein may be subject to export control regulations. Export might require a prior authorization from competent authorities.

**Non-automotive qualified products** — Unless this data sheet expressly states that this specific NXP Semiconductors product is automotive qualified, the product is not suitable for automotive use. It is neither qualified nor tested in accordance with automotive testing or application requirements. NXP Semiconductors accepts no liability for inclusion and/or use of non-automotive qualified products in automotive equipment or applications.

In the event that customer uses the product for design-in and use in automotive applications to automotive specifications and standards, customer (a) shall use the product without NXP Semiconductors' warranty of the product for such automotive applications, use and specifications, and (b) whenever customer uses the product for automotive applications beyond NXP Semiconductors' specifications such use shall be solely at customer's own risk, and (c) customer fully indemnifies NXP Semiconductors for any liability, damages or failed product claims resulting from customer design and use of the product for automotive applications beyond NXP Semiconductors' standard warranty and NXP Semiconductors' product specifications.

**Translations** — A non-English (translated) version of a document is for reference only. The English version shall prevail in case of any discrepancy between the translated and English versions.

## 16.4 Licenses

### Purchase of NXP ICs with HDMI technology

Use of an NXP IC with HDMI technology in equipment that complies with the HDMI standard requires a license from HDMI Licensing LLC, 1060 E. Arques Avenue Suite 100, Sunnyvale CA 94085, USA, e-mail: [admin@hdmi.org](mailto:admin@hdmi.org).

## 16.5 Trademarks

Notice: All referenced brands, product names, service names and trademarks are the property of their respective owners.

## 17. Contact information

For more information, please visit: <http://www.nxp.com>

For sales office addresses, please send an email to: [salesaddresses@nxp.com](mailto:salesaddresses@nxp.com)

**18. Contents**

**1 General description . . . . . 1**

**2 Features and benefits . . . . . 1**

**3 Ordering information . . . . . 2**

3.1 Ordering options . . . . . 2

**4 Block diagram . . . . . 2**

**5 Pinning information . . . . . 3**

5.1 Pinning . . . . . 3

5.2 Pin description . . . . . 4

**6 Functional description . . . . . 5**

**7 Power-up sequence . . . . . 5**

**8 Limiting values . . . . . 6**

**9 Recommended operating conditions . . . . . 6**

**10 Characteristics . . . . . 7**

10.1 Device general characteristics . . . . . 7

10.2 Switch channel characteristics . . . . . 7

10.3 Control signals characteristics . . . . . 8

**11 Package outline . . . . . 9**

**12 Packing information . . . . . 10**

**13 Soldering of SMD packages . . . . . 13**

13.1 Introduction to soldering . . . . . 13

13.2 Wave and reflow soldering . . . . . 13

13.3 Wave soldering . . . . . 14

13.4 Reflow soldering . . . . . 14

**14 Abbreviations . . . . . 15**

**15 Revision history . . . . . 16**

**16 Legal information . . . . . 17**

16.1 Data sheet status . . . . . 17

16.2 Definitions . . . . . 17

16.3 Disclaimers . . . . . 17

16.4 Licenses . . . . . 18

16.5 Trademarks . . . . . 18

**17 Contact information . . . . . 18**

**18 Contents . . . . . 19**

Please be aware that important notices concerning this document and the product(s) described herein, have been included in section 'Legal information'.

© NXP Semiconductors N.V. 2015. **All rights reserved.**

For more information, please visit: <http://www.nxp.com>  
 For sales office addresses, please send an email to: [salesaddresses@nxp.com](mailto:salesaddresses@nxp.com)

Date of release: 27 July 2015  
 Document identifier: CBTL04GP043

## X-ON Electronics

Largest Supplier of Electrical and Electronic Components

*Click to view similar products for [Analogue & Digital Crosspoint ICs](#) category:*

*Click to view products by [NXP](#) manufacturer:*

Other Similar products are found below :

[MT093AE1](#) [MT8808AE1](#) [ADV3203ASWZ](#) [AD8177ABPZ](#) [ISPGDX240VA-4B388](#) [VSC3308YKU](#) [LX64EV-3F100C](#) [ISPGDX240VA-4BN388](#) [LX256EV-5FN484C](#) [GX4002-INE3](#) [AD8112JSTZ](#) [AD8115ASTZ](#) [SN65LVCP22D](#) [ADV3205JSTZ](#) [SY89540UMY](#) [AD75019JPZ](#) [AD75019JPZ-REEL](#) [AD8106ASTZ](#) [AD8107ASTZ](#) [AD8108ASTZ](#) [AD8110ASTZ](#) [AD8111ASTZ](#) [AD8116JSTZ](#) [AD8152JBPZ](#) [AD8153ACPZ](#) [AD8155ACPZ](#) [AD8158ACPZ](#) [AD8159ASVZ](#) [ADN4604ASVZ](#) [AD8153ACPZ-RL7](#) [ADN4600ACPZ](#) [ADV3201ASWZ](#) [ADV3226ACPZ](#) [ADV3227ACPZ](#) [ADV3228ACPZ](#) [ADV3229ACPZ](#) [HMC858LC4B](#) [MAX4550CAI+](#) [EL4544IGZ](#) [HA4314BCPZ](#) [MAX9152EUE+T](#) [MAX9152ESE+](#) [MAX4359EWG+](#) [MAX3840ETJ+](#) [MAX4360EAX+](#) [MAX4360EAX+T](#) [MAX4549EAX+](#) [MAX4570CWI+](#) [MAX4549EAX+T](#) [MAX4570CAI+](#)