

Freedom Board for Kinetis K82F Hardware (FRDM-K82F)

User's guide

1. Introduction

The Freescale Freedom development platform is a set of software and hardware tools for evaluation and development. It is ideal for rapid prototyping of microcontroller-based applications. The Freescale Freedom K82 hardware, FRDM-K82F, is a simple yet sophisticated design featuring a Kinetis K series microcontroller built on the ARM® Cortex®-M4 core which features a floating point unit (FPU).

Contents

1. Introduction	1
2. FRDM-K82F overview.....	2
2.1. Hardware.....	2
3. FRDM-K82F Hardware Description	4
3.1. Power supply.....	4
3.2. Serial and Debug Adapter version 2 (OpenSDAv2.1).....	6
4. Microcontroller	8
5. Clocking	9
6. Universal Serial Bus (USB).....	10
7. VBAT.....	11
8. Accelerometer and Magnetometer.....	11
9. RGB LED.....	12
10. Serial Port.....	12
11. QuadSPI Memory.....	12
12. FlexIO Header.....	13
13. Reset.....	13
14. Push Button Switches	14
14.1. Touch interface.....	15
15. Debug.....	16
16. Add-On Modules.....	16
16.1. RF module.....	16
16.2. Bluetooth module	17
17. I/O Connectors	17
18. Arduino Compatibility.....	18
19. Jumper Table	18
20. Revision history	20

2. FRDM-K82F overview

FRDM-K82F can be used to evaluate the K80, K81, and K82 Kinetis K series devices. The FRDM-K82F board features the MK82FN256VLL15 MCU, which boasts a maximum operation frequency of 150 MHz, 256 KB of flash, a 256 KB RAM, a full-speed USB controller with available crystal-less operation, and analog and digital peripherals. The FRDM-K82F hardware is form-factor compatible with the Arduino™ R3 pin layout, providing a broad range of expansion board options. The onboard interface includes a six-axis digital accelerometer and magnetometer, an RGB LED, FlexIO header, and sufficient footprint to add an optional Bluetooth module (for use over UART) and RF module (for use over SPI).

The FRDM-K82F platform features OpenSDAv2.1, the Freescale open-source hardware embedded serial and debug adapter running an open-source bootloader. This circuit offers several options for serial communication, flash programming, and run-control debugging. OpenSDAv2.1 is an mbed™ HDK-compatible debug interface preloaded with the open-source CMSIS-DAP Interface firmware (mbed interface) for rapid prototyping and product development, with a focus on connected Internet of Things devices.

2.1. Hardware

The features of the FRDM-K82F hardware are as follows:

- MK82FN256VLL15 MCU—150 MHz, 256 KB flash memory, 256 KB RAM, low-power, QuadSPI controller, ROM Bootloader, and crystal-less USB in 100 LQFP package
- Dual role USB interface with USB connector
- RGB LED
- FXOS8700CQ—accelerometer and magnetometer
- Two user push buttons
- Two TSI touch pads
- Flexible power supply option: OpenSDAv2 USB, K82F USB, or external source
- Easy access to MCU input/output through Arduino R3 compatible I/O connectors
- Two 32 Mbit (4 MB) Dual On-board QuadSPI memory @ 1.8 V
- Dual Independent Voltage Domains: VDD and VDDIO_E
- Programmable OpenSDAv2 debug circuit supporting the CMSIS-DAP interface software that provides:
 - Mass storage device (MSD) flash programming interface
 - CMSIS-DAP debug interface over a USB HID connection providing run-control debugging and compatibility with IDE tools
 - Virtual serial port interface
- FlexIO Header compatible with OV7670 Camera
- Optional header for add-on RF module: nRF24L01+ Nordic 2.4 GHz radio

- Optional header for add-on Bluetooth module: JY-MCU BT board V1.05 BT

FRDM-K82F block diagram shows the block diagram of the FRDM-K82F design. The primary components and their placement on the hardware assembly are explained in FRDM-K82F primary component placement.

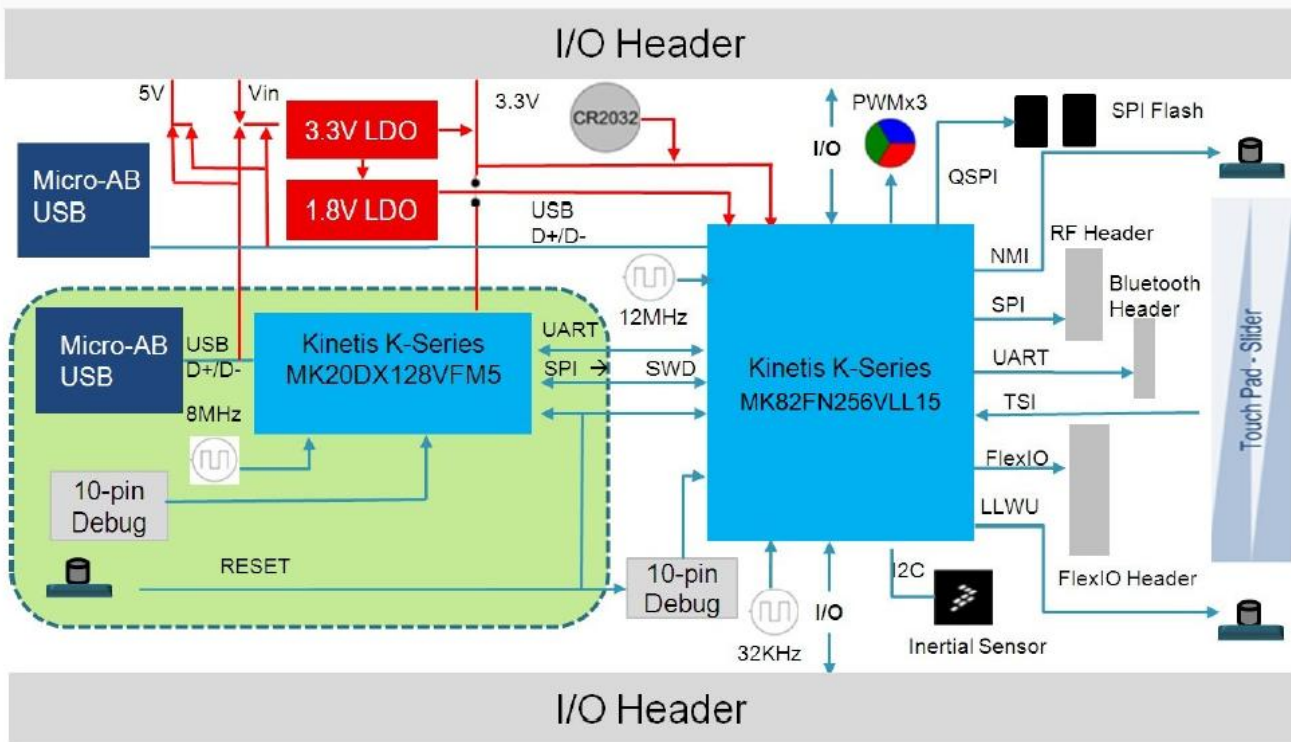

Figure 1. FRDM-K82F block diagram

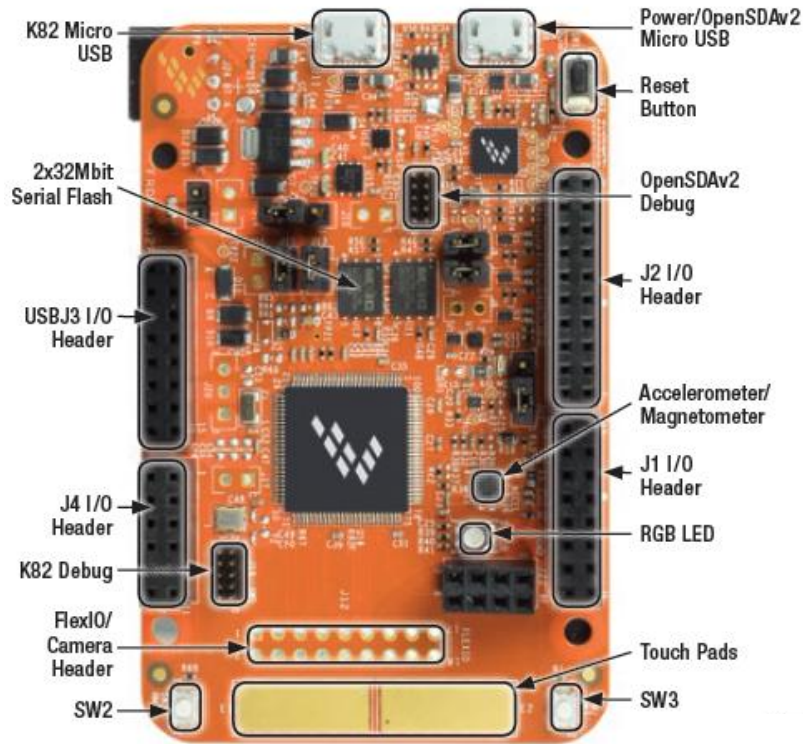

Figure 2. FRDM-K82F primary component placement

3. FRDM-K82F Hardware Description

3.1. Power supply

There are multiple power supply options on the FRDM-K82F board. It can be powered from either of the USB connectors, the VIN pin on the I/O header, DC jack (optional; not populated), or an off board 1.71–3.6 V supply from the 3.3 V pin on the I/O header. The USB, DC jack, and VIN supplies are regulated onboard using a 3.3 V linear regulator to produce the main power supply and a 1.8 V linear regulator to produce the VDDIO_E power supply. A direct voltage supply to the K82F MCU is also available via J15 and J13. The following table provides the operational details and requirements for the power supplies.

Table 1. FRDM-K82F power requirements

Supply Source	Valid Range	OpenSDAv2 Operational?	Regulated Onboard?
OpenSDAvs USB	5 V	Yes	Yes
K82F USB	5 V	No	Yes
P5-9V_VIN pin	5 V–9 V	No	Yes

Table 1. FRDM-K82F power requirements (continued)

Supply Source	Valid Range	OpenSDAv2 Operational?	Regulated Onboard?
3.3 V header (J15)	1.71 V–3.6 V	No	No
DC jack (not populated)	5 V–9 V	No	Yes

NOTE

The OpenSDAv2 circuit is only operational when a USB cable is connected and supplies power to the OpenSDAv2 USB. However, protection circuitry is in place to enable multiple sources to be powered at once.

ATTENTION

When 3.3 V power is supplied directly through the Freedom platform compatibility header J3, please enable protection diode D7 by opening J18 shorting header.

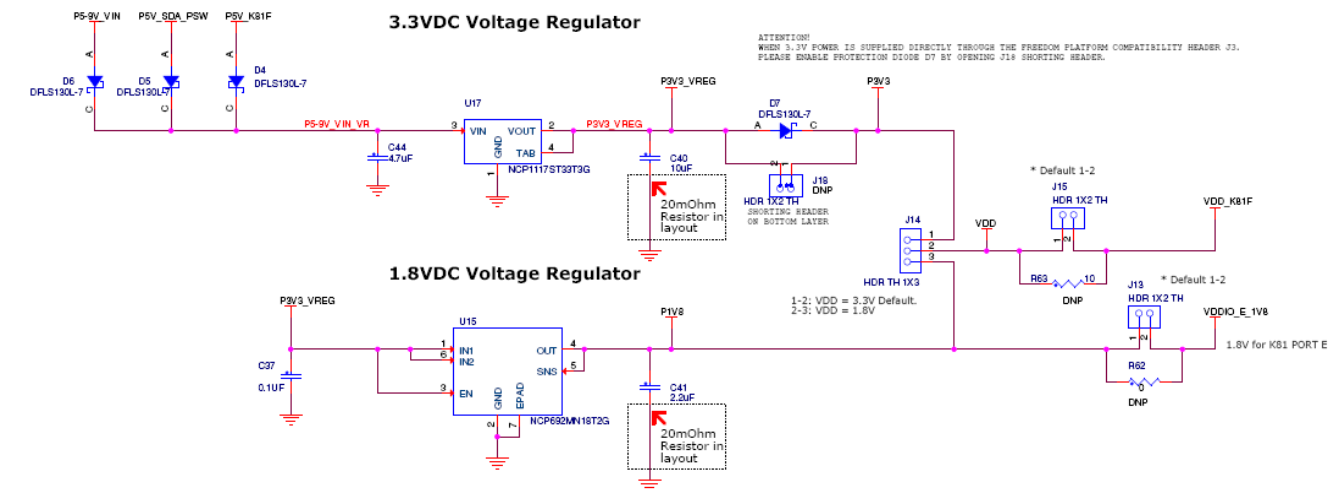

Figure 3. Power supply schematic

Table 2. FRDM-K82F power supplies

Power Supply Name	Description
P5-9V_VIN	Power supply from the VIN pin of the I/O headers (J3 pin 16). A Schottky diode provides back-drive protection.
DC_JACK	Power supplied from the DC Jack (J20; not populated). A Schottky diode provides back-drive protection.
P3V3_VREG	Regulated 3.3 V supply. Sources power to the P3V3 supply rail through a back-drive protection Schottky diode ¹ .
VDD_K81F	K82F MCU voltage supply. Header J15 provides a convenient means for energy consumption measurements.
VDDIO_E_1V8	K82F VDDIO_E MCU voltage supply. Header J13 provides a convenient means for energy consumption measurements.
P3V3_SDA	OpenSDAv2 circuit voltage supply.
P5V_USB	Nominal 5 V supplied to the I/O headers (J3 pin10).

3.2. Serial and Debug Adapter version 2 (OpenSDAv2.1)

OpenSDAv2 is a serial and debug adapter circuit which includes an open-source hardware design, an open-source bootloader, and debug interface software. It bridges serial and debug communications between a USB host and an embedded target processor as shown in [OpenSDA high-level](#) block diagram.

The hardware circuit is based on a Freescale Kinetis K20 family microcontroller (MCU) with 128 KB of embedded flash and an integrated USB controller. OpenSDAv2 comes preloaded with the CMSIS-DAP bootloader—an open-source mass storage device (MSD) bootloader, and the CMSIS-DAP interface firmware (also known as the mbed interface), which provides an MSD flash programming interface, a virtual serial port interface, and a CMSIS-DAP debug protocol interface. For more information on the OpenSDAv2 software, see mbed.org and <https://github.com/mbedmicro/CMSIS-DAP>.

¹By default, the linear regulator (U17) is a 3.3 V output regulator. This is a common footprint that enables the user to modify the assembly to use an alternative device, such as a 1.8 V output regulator. The K82F microcontroller has an operating range of 1.71 V to 3.6 V.

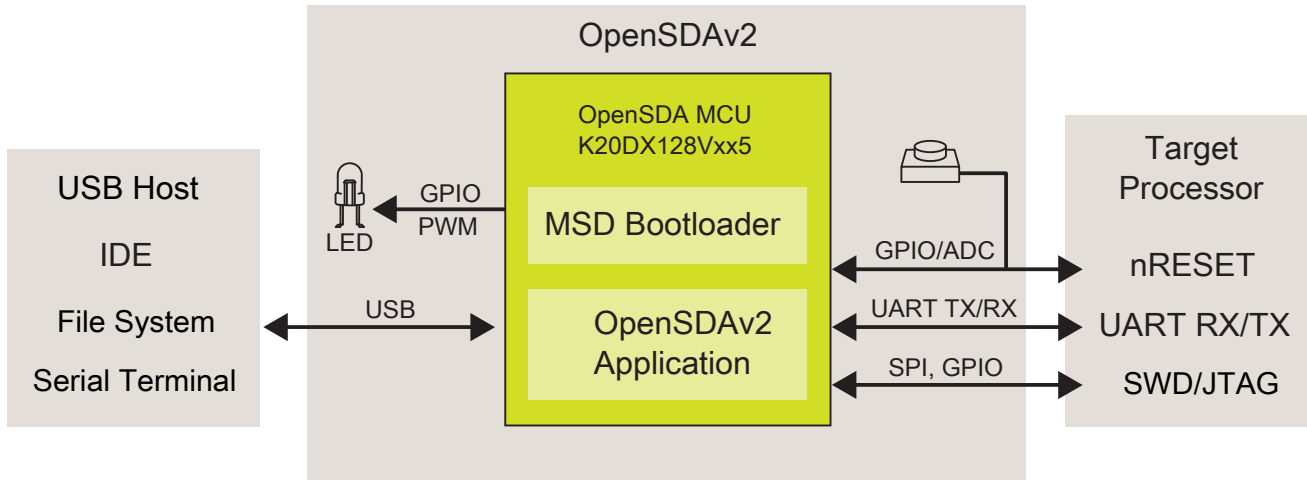

Figure 4. OpenSDA high-level block diagram

OpenSDAv2 is managed by a Kinetis K20 MCU built on the ARM Cortex-M4 core. The OpenSDAv2 circuit includes a status LED (D1) and a push button (SW1). The push button asserts the Reset signal to the K82F target MCU. It can also be used to place the OpenSDAv2 circuit into bootloader mode. SPI and GPIO signals provide an interface to either the SWD debug port or the K20. Additionally, signal connections are available to implement a UART serial channel. The OpenSDAv2 circuit receives power when the USB connector J5 is plugged into a USB host.

3.2.1. Debug interface

Signals with SPI and GPIO capability are used to connect directly to the SWD of the K82F. These signals are also sent to a standard 10-pin (0.05 inch) Cortex debug connector (J19). It is possible to isolate the K82F MCU from the OpenSDAv2 circuit and use J19 to connect to an off-board MCU. To do this, cut the trace on the bottom side of the PCB that connects J17 pin 2 to J19 pin 4. This will disconnect the SWD_CLK pin to the K82F so that it will not interfere with communication to an off-board MCU connected to J17.

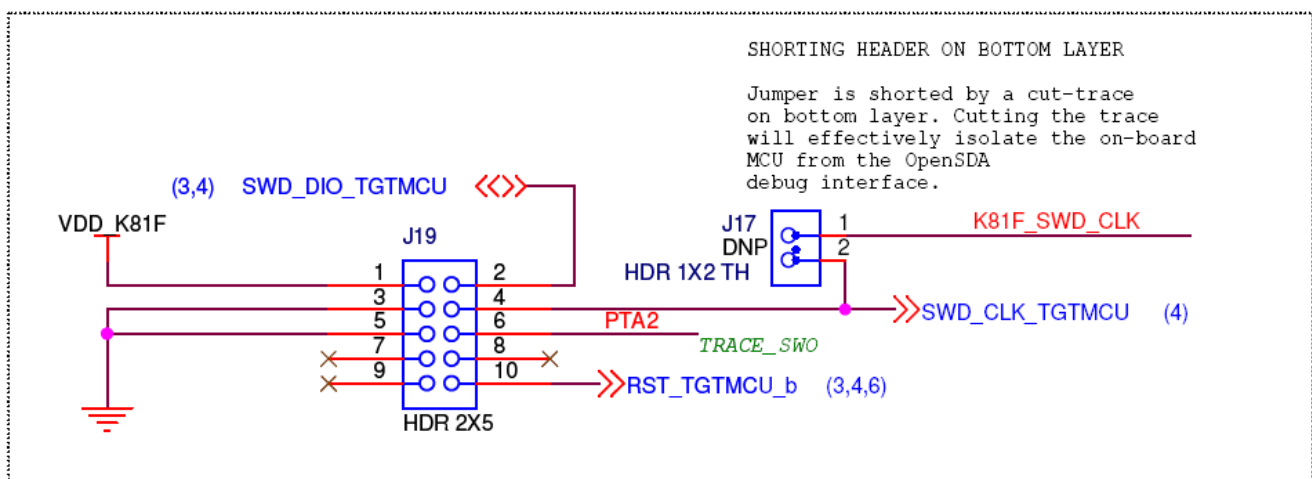

Figure 5. SWD debug connector

The J19 header is populated by default. A mating cable, such as a Samtec FFSD IDC cable, can then be used to connect from the OpenSDAv2 of the FRDM-K82F to an off-board SWD connector.

3.2.2. Virtual serial port

A serial port connection is available between the OpenSDAv2 MCU and pins PTC14 and PTC15 of the K82.

4. Microcontroller

The FRDM-K82F features the MK82FN256VLL15 MCU. This 150 MHz microcontroller is part of the Kinetis K2x family and is implemented in a 100 LQFP package. The FRDM-K82F board also supports the K80 and K81 MCUs. The following table describes some of the features of the MK82FN256VLL15 MCU that is populated on this board.

Table 3. MK82FN256VLL15 MCU features

Feature	Description
Performance	<ul style="list-style-type: none"> Up to 150 MHz ARM Cortex-M4 based core with DSP instructions and Single Precision Floating Point unit
Memory and memory expansion	<ul style="list-style-type: none"> 256 KB program flash memory and 256 KB RAM Dual QuadSPI with XIP FlexBus external bus interface and SDRAM controller
Analog modules	<ul style="list-style-type: none"> One 16-bit SAR ADCs, two 6-bit DAC and one 12-bit DAC Two analog comparators (CMP) containing a 6-bit DAC and programmable reference input Voltage reference 1.2 V
Communication interfaces	<ul style="list-style-type: none"> USB full-,low-speed On-the-Go controller Secure Digital Host Controller (SDHC) FlexIO One I2S module, three SPI, four I2C modules and five LPUART modules EMVSIM module with ISO7816 smart card support
Security	<ul style="list-style-type: none"> Hardware random-number generator Supports DES, AES, SHA accelerator (CAU) Multiple levels of embedded flash security
Timers	<ul style="list-style-type: none"> One 4 channel-Periodic interrupt timer Two 16-bit low-power timer PWM modules Two 8-channel motor control/general purpose/PWM timers Two 2-channel quadrature decoder/general purpose timers Real-time clock with independent 3.3 V power domain Programmable delay block
Human machine interface	<ul style="list-style-type: none"> Low-power hardware touch sensor interface (TSI) General-purpose I/O
Operating Characteristics	<ul style="list-style-type: none"> Main VDD Voltage and Flash write voltage range:1.71 V–3.6 V Temperature range (ambient): -40 to 105 °C Independent VDDIO for PORTE (QuadSPI): 1.71 V–3.6 V

5. Clocking

The Kinetis K82F MCU starts up from an internal digitally-controlled oscillator (DCO). Software can enable the main external oscillator (EXTAL0/XTAL0) if desired. The external oscillator/resonator can range from 32.768 kHz up to 32 MHz. The default external source for the MCG oscillator inputs (EXTAL) is a 12 MHz crystal.

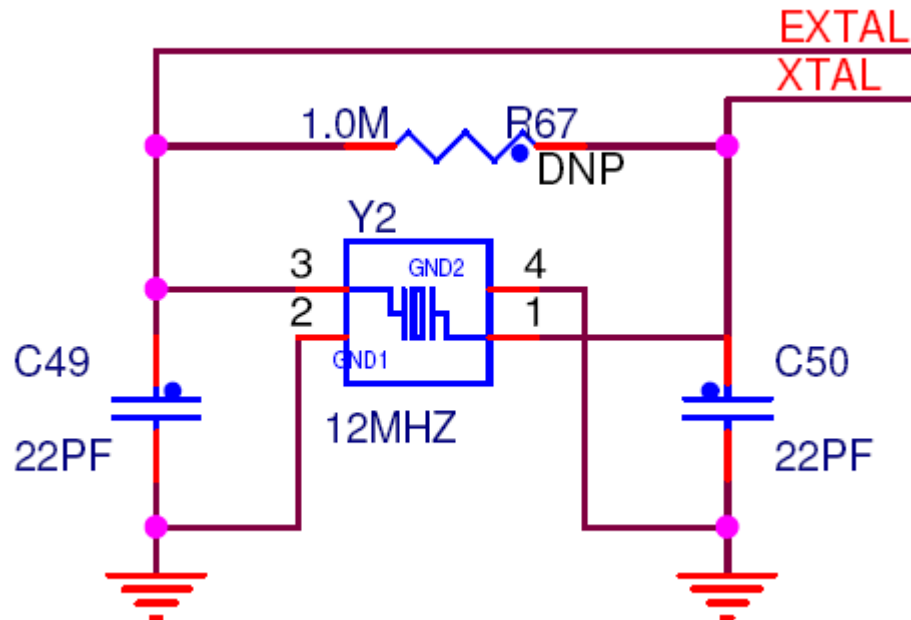

Figure 6. 8 MHz crystal clock source for MCU

By default, the 32.768 kHz crystal is connected to the K82F MCU's RTC oscillator inputs.

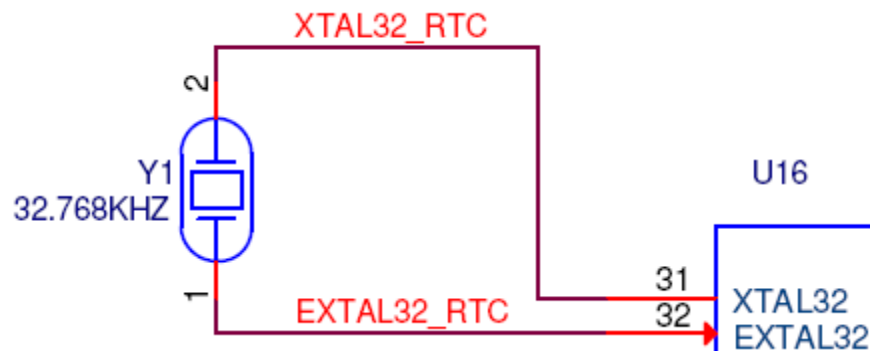

Figure 7. 32.768 kHz crystal for RTC

6. Universal Serial Bus (USB)

The MK82FN256VLL15 MCU features a full-speed/low-speed USB module with on-the-go/host/device capability and built-in transceiver. The FRDM-K82F board routes the USB D+ and D signals from the MK82FN256VLL15 MCU directly to the onboard micro USB connector (J11).

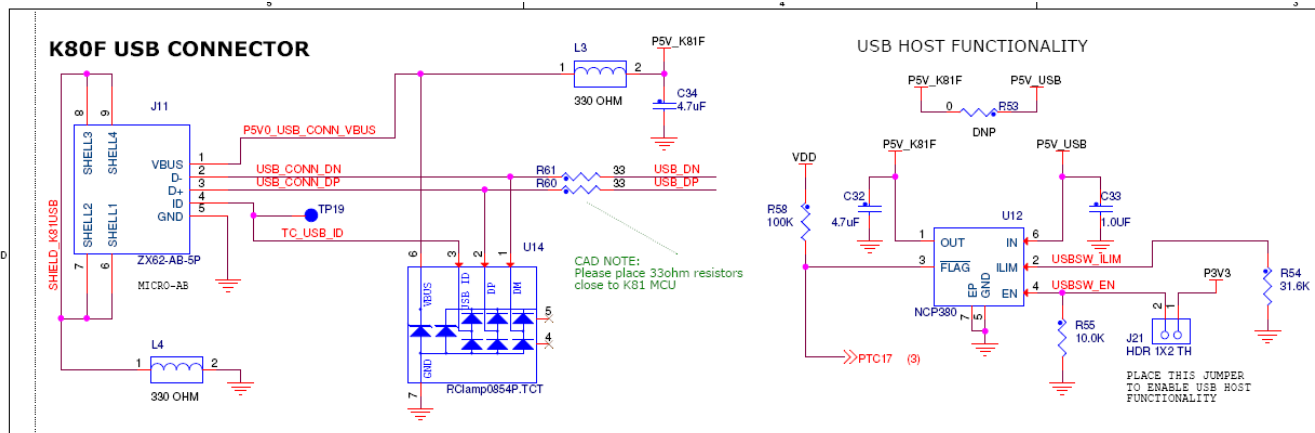

Figure 8. K82F USB port

When the FRDM-K82F board is operating in USB host mode, J21 must be shunted to supply 5 V power to VBUS (J11 pin 1). The source of 5 V power can be the OpenSDAv2 USB port (J5), pin 10 of the J3 I/O header, or P5-9V_VIN DC-DC converter of J20.

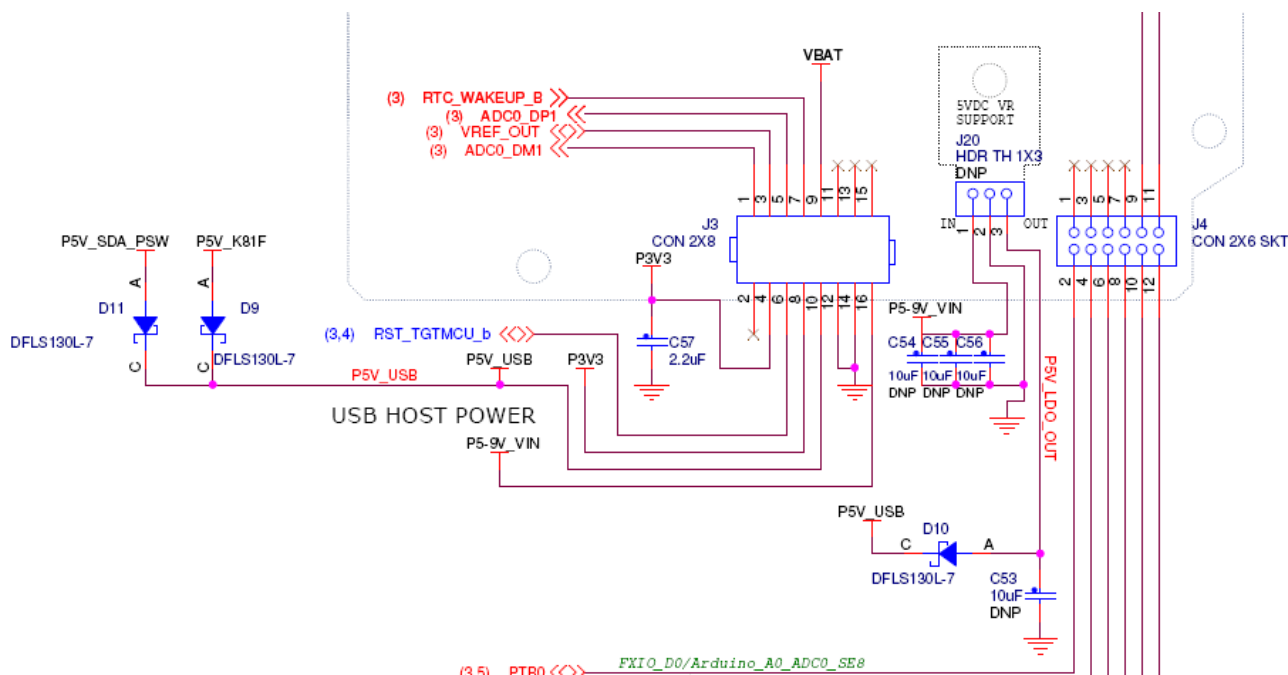

Figure 9. K82F USB port power inputs for host mode

7. VBAT

The Real Time Clock (RTC) module is powered on its own domain. The FRDM-K82F provides a battery holder for a coin cell battery that can be used as the VBAT supply. The holder can accept common 20mm diameter 3V lithium coin cell batteries (e.g. 2032, 2025).

If a coin cell battery is to be used, add a small amount of solder to the coin cell ground pad before adding the battery holder. Also, it is recommended to populate D12 as a protection diode when using a coin cell battery.

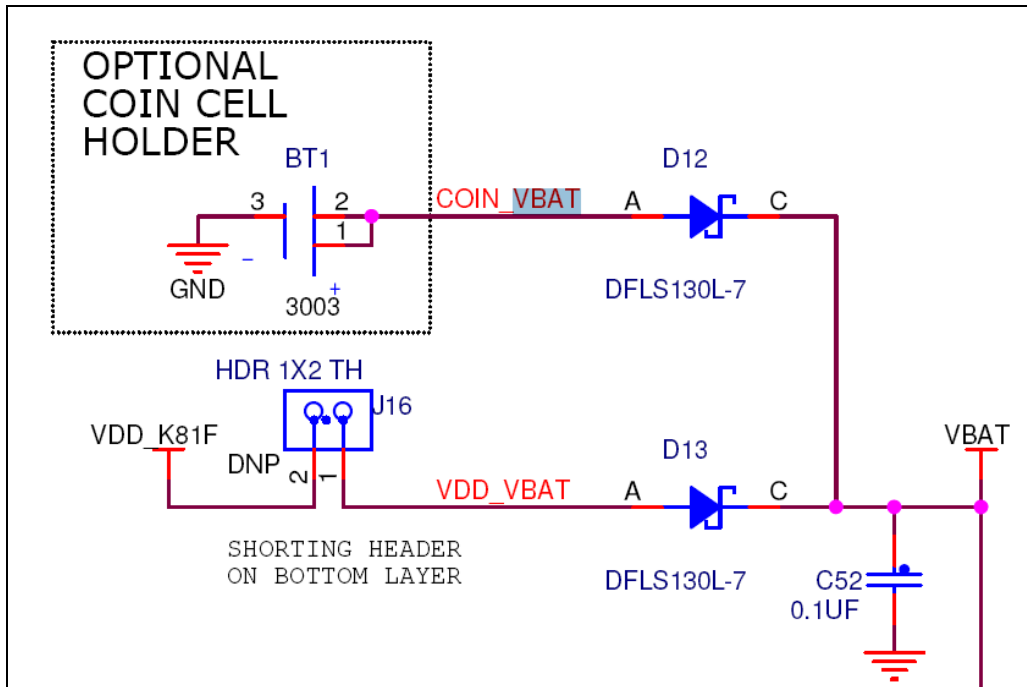

Figure 10. Coin cell

8. Accelerometer and Magnetometer

A Freescale FXOS8700CQ low-power, six-axis Xtrinsic sensor is interfaced through an I²C bus and two GPIO signals, as shown in the following table. By default, the I²C address is 0x1C (pull-up on SA1 and pull-down on SA0).

Table 4. Accelerometer and magnetometer signals connection

FXOS8700Q	K82F Connection
SCL	PTA2/ I2C3_SCL
SDA	PTA1/ I2C3_SDA
INT1	PTC13

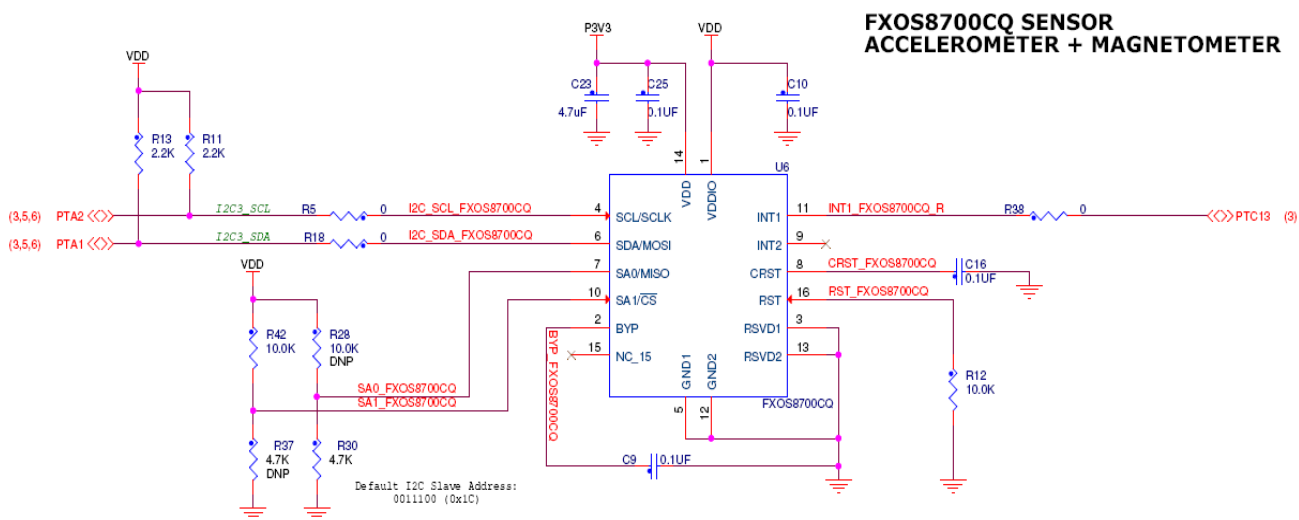

Figure 11. Accelerometer and magnetometer

9. RGB LED

An RGB LED is connected through GPIO pins. Signal connections are shown in the following table:

Table 5. LED signal connection

RGB LED	K82F Connection
Red	PTC8
Green	PTC9
Blue	PTC10

10. Serial Port

The primary serial port interface signals are PTC14 UART4_RX and PTC15 UART4_TX. These signals are connected to the OpenSDAv2 circuit.

11. QuadSPI Memory

The FRDM-K82F also includes dual QuadSPI memory with execute in place (XiP) and On The Fly AES Decryption (OTFAD) capability. The on-board QuadSPI used is Macronix MX25U3235FZNI, which are each 32 Mb (4MB) in size. The QuadSPI interface offers up to 100 MHz performance for Single Data Rate (SDR). The QuadSPI is also supported by the internal Kinetis BootROM.

12. FlexIO Header

There is an 18 pin header with 11 FlexIO signals connected. It is compatible with the OV7670 camera when placed on the bottom of the board.

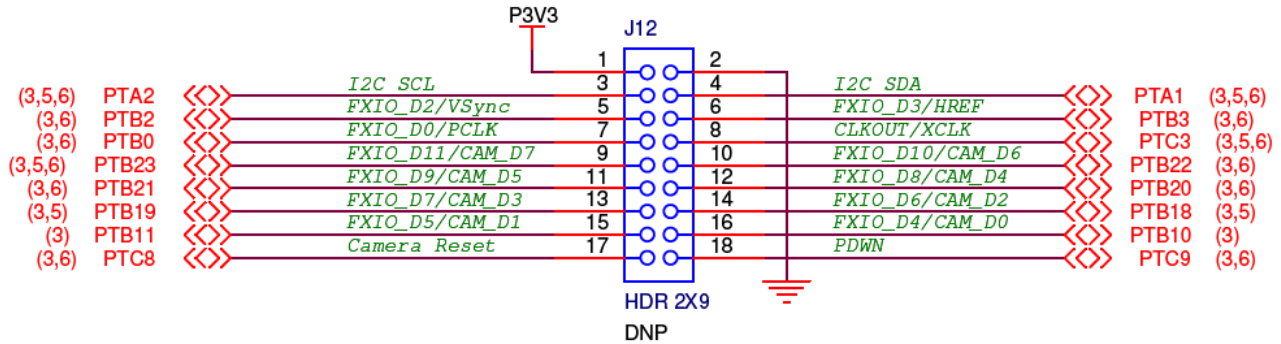

Figure 12. FlexIO/camera header

13. Reset

The Reset signal on the K20 is connected externally to a push button, SW1, and also to the OpenSDAv2 circuit. The reset button can be used to force an external reset event on the target MCU. The reset button can also be used to force the OpenSDAv2 circuit into boot loader mode. For more details, see the following figure:

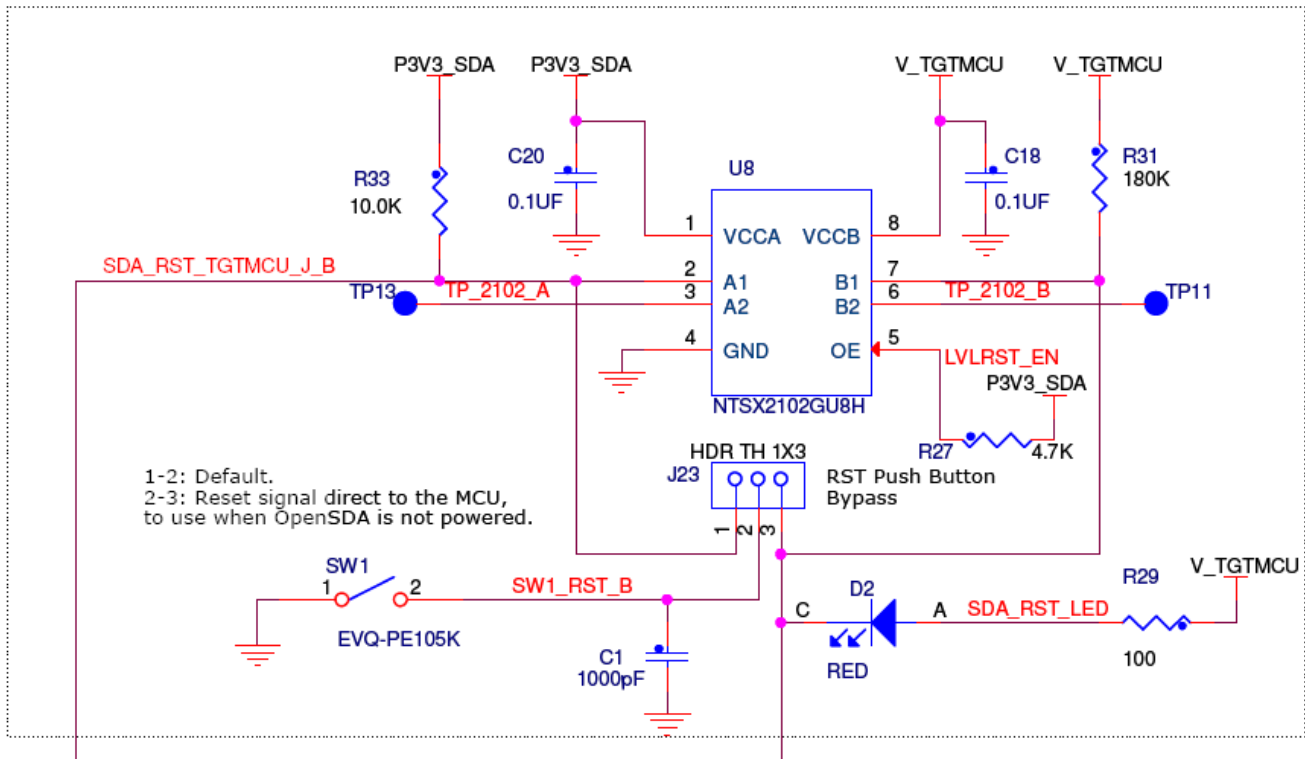

Figure 13. Reset circuit

14. Push Button Switches

Two push buttons, SW2 and SW3, are available on the FRDM-K82F board. SW2 is connected to PTA4 and SW3 is connected to PTC6. Besides the general purpose input/output functions, SW2 can be also be used as a low-leakage wakeup (LLWU) source.

Table 6. Push button switch connections

Switch	K82F Connection
SW2	PTA4/NMI_B
SW3	PTC6/LLWU_P10

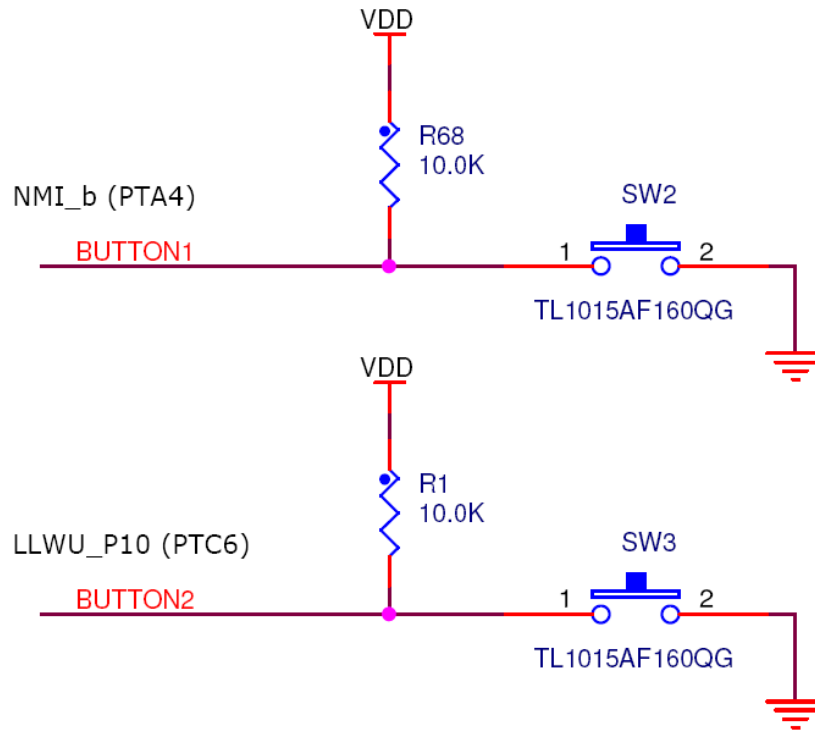

Figure 14. Push button switches

14.1. Touch interface

The touch-sensing input (TSI) module of the Kinetis microcontrollers provides capacitive touch-sensing detection with high sensitivity and enhanced robustness. Each TSI pin implements the capacitive measurement of an electrode. There are two individual electrodes on-board the FRDM-K82F that simulates pushbuttons. TSI0_CH11 (PTB18) and TSI0_CH12 (PTB19) are connected to the capacitive pads.

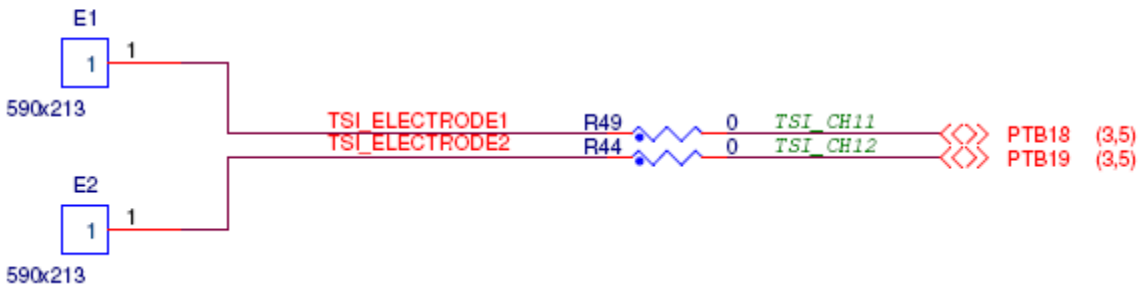

Figure 15. TSI touch pad

15. Debug

The debug interface on the MK82FN512VDC12 MCU is a serial wire debug (SWD) port with trace output capability. There are two debug interfaces on the FRDM-K82F: an onboard OpenSDAv2 circuit (J5) and a K82F direct SWD connection via a 10-pin header (J19). To use an external debugger, such as J-Link on J19, you may need to disconnect the OpenSDAv2 SWD circuit from the K82F by removing jumpers J6 and J7.

16. Add-On Modules

16.1. RF module

An optional header (J22) on the FRDM-K82F supports communication with a 2.4 GHz nRF24L01+ Nordic radio module over SPI. Alternatively, any SPI-based device or module can be used with this header.

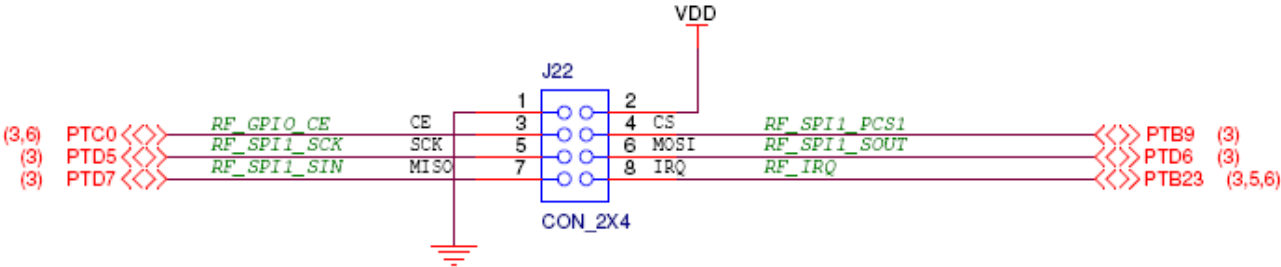

Figure 16. Optional add-on 2.4 GHz RF module

16.2. Bluetooth module

An optional header (J24) on the FRDM-K82F supports communication with an add-on Bluetooth interface, such as the JY-MCU BT V1.05 BT wireless Bluetooth module, over a UART.

Alternatively, any serial (SCI) module can be used with this connector. Note that the serial signals are 3 V levels and do not conform to RS-232 logic levels, so a level shifter (like a Maxim DS3232) should be used with RS-232 devices.

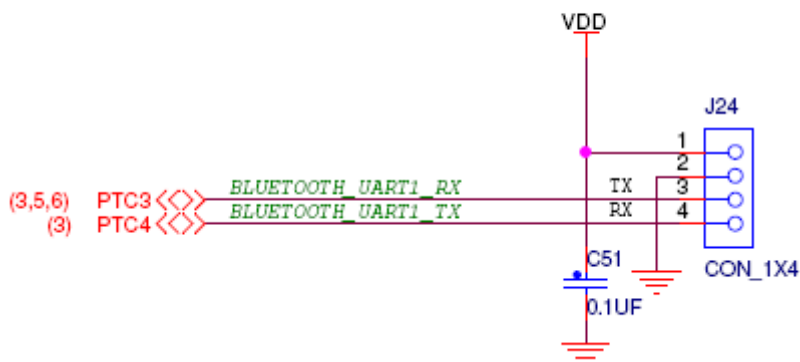

Figure 17. Optional add-on Bluetooth module

17. I/O Connectors

The MK82FN256VLL15 microcontroller is packaged in a 100-pin LQFP. Some pins are used in onboard circuitry, but some are directly connected to one of the four I/O headers (J1, J2, J3, and J4).

The pins on the K82F microcontroller are named for their general purpose input/output (GPIO) port pin function. For example, the first pin on Port A is referred as PTA1. The name assigned to the I/O connector pin corresponds to the GPIO pin of the K82F.

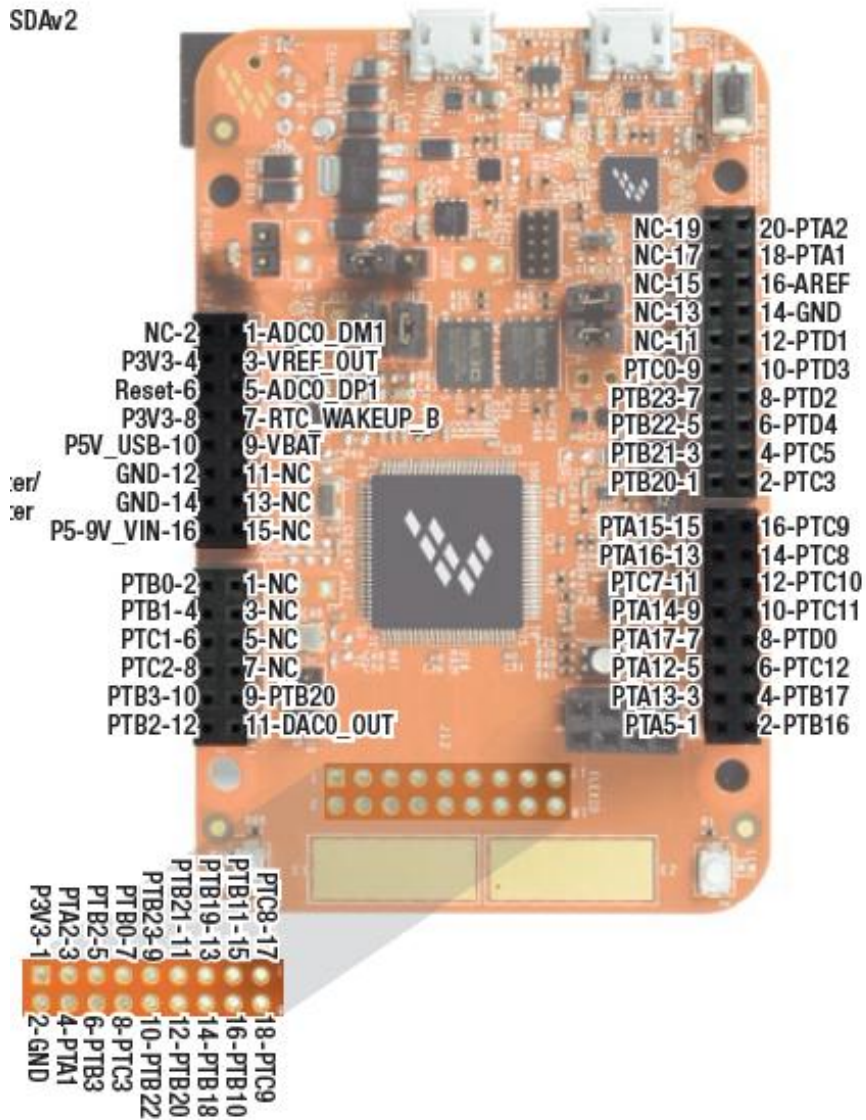

Figure 17. FRDM-K82F I/O header pinout

18. Arduino Compatibility

The I/O headers on the FRDM-K82F board are arranged to enable compatibility with peripheral boards (known as shields) that connect to Arduino and Arduino-compatible microcontroller boards. The outer rows of pins (even numbered pins) on the headers share the same mechanical spacing and placement with the I/O headers on the Arduino Revision 3 (R3) standard.

19. Jumper Table

The following table shows the available jumper options on the FRDM-K82F board. The default jumper settings are shown in **bold**.

Table 7. FRDM-K82F Jumper Table

Jumper	Option	Setting	Description
J6	SWD_CLK	1-2	OpenSDA SWD_CLK isolation jumper
J7	SWD_DIO	1-2	OpenSDA SWD_DIO isolation jumper
J8	OpenSDA Reset	1-2*	OpenSDA reset isolation jumper (*shorted on board)
J10	OpenSDA Power	1-2*	Isolate power to OpenSDA circuit (*shorted on board)
J13	VDDIO_E Supply	1-2	Measurement point for K82 VDDIO_E power domain
J14	VDD Selection	1-2 2-3	VDD Domain is 3.3 V VDD Domain is 1.8 V
J15	VDD Supply	1-2	Measurement point for K82 VDD power domain
J17	SWD_CLK	1-2*	Isolate SWD_CLK from SWD header (*shorted on board)
J18	3.3 V Domain	1-2*	Power 3.3 V domain (*shorted on board)
J20	5 V DC Support	DNP	Optional 5 V connection
J21	USB Host	1-2	Host Enable
J23	Reset Push Button Bypass	1-2	Reset button connected to OpenSDA

17 References

The following references are available on www.freescale.com/FRDM-K82F:

- *FRDM-K82F Quick Start Guide*
- *FRDM-K82F Schematic*
- *FRDM-K82F Design Package*

The following reference is available on www.freescale.com/kboot:

- Kinetis Flashloader

20. Revision history

Table 8. Sample revision history

Revision number	Date	Substantive changes
0	11/2015	Initial release

How to Reach Us:

Home Page:
freescale.com

Web Support:
freescale.com/support

Information in this document is provided solely to enable system and software implementers to use Freescale products. There are no express or implied copyright licenses granted hereunder to design or fabricate any integrated circuits based on the information in this document.

Freescale reserves the right to make changes without further notice to any products herein. Freescale makes no warranty, representation, or guarantee regarding the suitability of its products for any particular purpose, nor does Freescale assume any liability arising out of the application or use of any product or circuit, and specifically disclaims any and all liability, including without limitation consequential or incidental damages. “Typical” parameters that may be provided in Freescale data sheets and/or specifications can and do vary in different applications, and actual performance may vary over time. All operating parameters, including “typicals,” must be validated for each customer application by customer’s technical experts. Freescale does not convey any license under its patent rights nor the rights of others. Freescale sells products pursuant to standard terms and conditions of sale, which can be found at the following address: freescale.com/SalesTermsandConditions.

Freescale and the Freescale logo are trademarks of Freescale Semiconductor, Inc., Reg. U.S. Pat. & Tm. Off.

ARM, the ARM powered logo, Cortex, and mbed are registered trademarks of ARM Limited (or its subsidiaries) in the EU and/or elsewhere.

© 2015 Freescale Semiconductor, Inc. All rights reserved.

Document Number: FRDMK82FUG
Rev. 0
11/2015



X-ON Electronics

Largest Supplier of Electrical and Electronic Components

Click to view similar products for [Development Boards & Kits - ARM category](#):

Click to view products by [NXP manufacturer](#):

Other Similar products are found below :

[SAFETI-HSK-RM48](#) [PICOHOBBITFL](#) [CC-ACC-MMK-2443](#) [TWR-MC-FRDMKE02Z](#) [EVALSPEAR320CPU](#) [EVB-SCMIMX6SX](#)
[MAX32600-KIT#](#) [TMDX570LS04HDK](#) [TXSD-SV70](#) [OM13080UL](#) [EVAL-ADUC7120QSPZ](#) [OM13082UL](#) [TXSD-SV71](#)
[YGRPEACHNORMAL](#) [OM13076UL](#) [PICODWARFFL](#) [YR8A77450HA02BG](#) [3580](#) [32F3348DISCOVERY](#) [ATTINY1607](#) [CURIOSITY](#)
[NANO](#) [PIC16F15376](#) [CURIOSITY NANO BOARD](#) [PIC18F47Q10](#) [CURIOSITY NANO](#) [VISIONSTK-6ULL V.2.0](#) [80-001428](#) [DEV-17717](#)
[EAK00360](#) [YR0K77210B000BE](#) [RTK7EKA2L1S00001BE](#) [MAX32651-EVKIT#](#) [SLN-VIZN-IOT](#) [LV18F V6 DEVELOPMENT SYSTEM](#)
[READY FOR AVR BOARD](#) [READY FOR PIC BOARD](#) [READY FOR PIC \(DIP28\)](#) [EVB-VF522R3](#) [AVRPLC16 V6 PLC SYSTEM](#)
[MIKROLAB FOR AVR XL](#) [MIKROLAB FOR PIC L](#) [MINI-AT BOARD - 5V](#) [MINI-M4 FOR STELLARIS](#) [MOD-09.Z](#) [BUGGY +](#)
[CLICKER 2 FOR PIC32MX + BLUETOOT](#) [1410](#) [LETS MAKE PROJECT PROGRAM. RELAY PIC](#) [LETS MAKE - VOICE](#)
[CONTROLLED LIGHTS](#) [LPC-H2294](#) [DSPIC-READY2 BOARD](#) [DSPIC-READY3 BOARD](#) [MIKROBOARD FOR ARM 64-PIN](#)
[MIKROLAB FOR AVR](#)