



Development tool for Kinetis V series MCUs and digital signal controllers

# High-Voltage Development Platform

Our high-voltage development platform is an evaluation and development solution for Kinetis V series MCUs and digital signal controllers (DSCs).

### TARGET APPLICATIONS

- ▶ PMSM, BLDC and ACIM motor control algorithms
- ▶ Industrial drives
- ▶ Compressors
- ▶ Washing machines
- ▶ Dishwashers
- ▶ Refrigerators
- ▶ Pumps, fans
- ▶ Air conditioning units

The platform enables development of 3-phase PMSM, BLDC and ACIM motor control and power factor correction (PFC) solutions in a safe high-voltage environment. The High-Voltage Development Platform is an isolated solution that provides the development base for the controller cards supporting MCUs. The platform comes complete with a Kinetis KV46F150M controller card.

Control of the motor control stage and PFC stage is carried out via a single MCU. Input voltage is 85–240 V AC, with output power of the motor stage up to 1 KW, with the ability to drive a 1.2 Hp motor, and 800 watts when using the PFC stage with the motor stage.

The High-Voltage Development Platform is fully supported by a comprehensive enablement environment, alongside the many reference solutions that will be continuously developed to support this platform built on our embedded motor control and power conversion libraries.

### DEVELOPMENT TOOLS

#### Embedded motor control and power conversion libraries

- ▶ Extensive suite of complimentary software libraries for motor and power control applications
- ▶ A group of algorithms, ranging from basic mathematics operations to advanced transformations and observers, which can easily be incorporated into complex real-time control applications

#### Proprietary MQX™ RTOS

- ▶ Our proprietary MQX RTOS is a full-featured complimentary real-time operating system including the MQX kernel, TCP/IP stack, embedded MS-DOS file system, and more.



- ▶ The mQX multitasking kernel provides pre-emptive scheduling, fast interrupt response, extensive inter-process communication and synchronization facilities.

### Kinetis Software Development Kit (SDK)

- ▶ Extensive suite of robust peripheral drivers, stacks, middleware and example applications designed to simplify and accelerate application development on any Kinetis MCU
- ▶ The Kinetis SDK is complimentary and includes full source code under a permissive open-source license for all hardware abstraction and peripheral driver software.

### Processor Expert Software

- ▶ Building on the Kinetis SDK drivers, the processor expert software configuration tool is a development system to create, configure, optimize, migrate, and deliver software components that generate source code for our silicon.

### Integrated Development Environments (IDE)

- ▶ Kinetis Design Studio IDE
  - No-cost integrated development environment (IDE) for Kinetis MCUs
  - Eclipse and GCC-based IDE for C/C++ editing, compiling and debugging
- ▶ IAR Embedded Workbench®
- ▶ ARM Keil® Microcontroller Development Kit
- ▶ CodeWarrior development studio for Microcontrollers 10.6
- ▶ Atollic® TrueSTUDIO®
- ▶ Green Hills Software MULTI
- ▶ Broad ARM ecosystem support through the Connect Partner Program

## HIGH-VOLTAGE MOTOR CONTROL DEVELOPMENT KIT BLOCK DIAGRAM

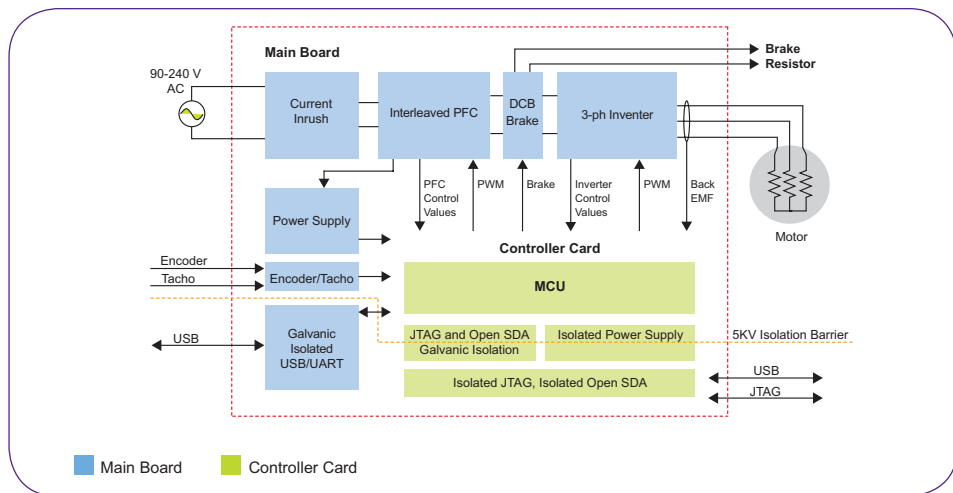

## HIGH-VOLTAGE DEVELOPMENT PLATFORM FEATURES AND BENEFITS

Features	Benefits
1 KW Motor driver stage	Drive BLDC, PMSM or ACIM motors up to 1.2 Hp
800 W Interleaved PFC stage	Develop motor systems that also incorporate PFC or standalone PFC systems
Detailed analog sensing	Includes all sense interfacing needed to develop a complete motor control with PFC solution regardless of whether it is a BLDC, PMSM or ACIM solution with or without sensor
Motor speed/position sensors interface: Encoder, Hall, Tacho generator	Allows the development of sensed solutions across all algorithms using all the main sensor types
Over voltage comparator with DC-brake resistor interface	Suitable for high dynamics drives, and safe PFC algorithm tuning
Current Inrush circuit	Safely cuts off at 14 amps during startup
Hardware over-current fault protection	Integrated protection hardware ensures no damage to your motor should an over-current occur
Support for multiple MCUs via low cost plug in controller cards	A single high-voltage environment that can be used to develop any Kinetis V series MCU or one of our proprietary DSC solutions
Isolated interfaces	All interfaces to the platform, USB/UART/JTAG are all galvanically isolated from the high voltage ensuring maximum safety up to 5 KV
Robust aluminum enclosure	Physical isolation from high voltage

## HIGH-VOLTAGE DEVELOPMENT PLATFORM PACKAGE OPTIONS

Part Number	Description	Price (USD)
HVP-MC3PH	HVP-MC3PH High-Voltage Development Platform with HVP-KV46F150M Controller Card	\$600
HVP-KV46F150M	KV64 150 MHz ARM® Cortex®-M4 MCU Controller Card	\$50
HVP-KV31F120M	KV31 120 MHz ARM Cortex-M4 MCU Controller Card	\$50
HVP-KV10Z32	KV10 75 MHz ARM Cortex-M0+ MCU Controller Card	\$50
HVP-56F82748	MC56F82748 Digital Signal Controller (DSC) Controller Card	\$50
HVP-KV11Z75M	KV11 75 MHz ARM-Cortex-M0+ MCU Controller Card	\$50

[www.nxp.com/HVP](http://www.nxp.com/HVP); [www.nxp.com/Kinetis](http://www.nxp.com/Kinetis); [www.nxp.com/Kinetis/VSeries](http://www.nxp.com/Kinetis/VSeries) or [www.nxp.com/DSC](http://www.nxp.com/DSC)

© 2015 Freescale Semiconductor, Inc.

CodeWarrior, Kinetis, Processor Expert and Tower are trademarks of Freescale Semiconductor, Inc., Reg. U.S. Pat. & Tm. Off. All other product or service names are the property of their respective owners. ARM, Cortex and Keil are registered trademarks of ARM Limited (or its subsidiaries) in the EU and/or elsewhere. All rights reserved.

Document Number:  
HVPPS REV 2

## X-ON Electronics

Largest Supplier of Electrical and Electronic Components

*Click to view similar products for [Development Boards & Kits - ARM category](#):*

*Click to view products by [NXP manufacturer](#):*

Other Similar products are found below :

[SAFETI-HSK-RM48](#) [PICOHOBBITFL](#) [CC-ACC-MMK-2443](#) [TWR-MC-FRDMKE02Z](#) [EVALSPEAR320CPU](#) [EVB-SCMIMX6SX](#)  
[MAX32600-KIT#](#) [TMDX570LS04HDK](#) [TXSD-SV70](#) [OM13080UL](#) [EVAL-ADUC7120QSPZ](#) [OM13082UL](#) [TXSD-SV71](#)  
[YGRPEACHNORMAL](#) [OM13076UL](#) [PICODWARFFL](#) [YR8A77450HA02BG](#) [3580](#) [32F3348DISCOVERY](#) [ATTINY1607](#) [CURIOSITY](#)  
[NANO](#) [PIC16F15376](#) [CURIOSITY NANO BOARD](#) [PIC18F47Q10](#) [CURIOSITY NANO](#) [VISIONSTK-6ULL V.2.0](#) [80-001428](#) [DEV-17717](#)  
[EAK00360](#) [YR0K77210B000BE](#) [RTK7EKA2L1S00001BE](#) [MAX32651-EVKIT#](#) [SLN-VIZN-IOT](#) [LV18F V6 DEVELOPMENT SYSTEM](#)  
[READY FOR AVR BOARD](#) [READY FOR PIC BOARD](#) [READY FOR PIC \(DIP28\)](#) [EVB-VF522R3](#) [AVRPLC16 V6 PLC SYSTEM](#)  
[MIKROLAB FOR AVR XL](#) [MIKROLAB FOR PIC L](#) [MINI-AT BOARD - 5V](#) [MINI-M4 FOR STELLARIS](#) [MOD-09.Z](#) [BUGGY +](#)  
[CLICKER 2 FOR PIC32MX + BLUETOOT](#) [1410](#) [LETS MAKE PROJECT PROGRAM. RELAY PIC](#) [LETS MAKE - VOICE](#)  
[CONTROLLED LIGHTS](#) [LPC-H2294](#) [DSPIC-READY2 BOARD](#) [DSPIC-READY3 BOARD](#) [MIKROBOARD FOR ARM 64-PIN](#)  
[MIKROLAB FOR AVR](#)