



# JN5179-001-M1x

ZigBee 3.0, ZigBee PRO, Thread and IEEE802.15.4 modules

Rev. 2.0 — 26 October 2016

Product data sheet

## 1. General description

---

The JN5179-001-M1x (with x = 0, 3 or 6) module family provides designers with a ready-made component that provides a fully integrated solution for applications, using the IEEE802.15.4 standard in the 2.4 GHz - 2.5 GHz ISM frequency band, including ZigBee Smart Energy and Home Automation and can be quickly and easily included in product designs. The modules integrate all of the RF components required, removing the need to perform expensive RF design and test. Products can be designed by simply connecting sensors and switches to the module IO pins. The modules use NXP's single chip IEEE802.15.4 wireless microcontroller, allowing designers to make use of the extensive chip development support material. Hence, this range of modules allows designers to bring wireless applications to market in the minimum time with significantly reduced development effort and cost.

3 variants are available: JN5179-001-M10, JN5179-001-M13 and JN5179-001-M16. All modules have FCC modular approval. The JN5179-001-M10 and JN5179-001-M13 are also CE-compliant and subject to a Notified Body Opinion.

The variants available are described in the [Table 1](#).

### 1.1 Regulatory Approvals

The JN5179-001-M10 and JN5179-001-M13 have been tested against the requirements of the following European standards.

- Radio EN 300 328 v 1.9.1
- EMC, EN 301 489-17 v 2.2.1, EN 62479 2010, EN 301 489-1 v 1.9.2
- Basic Safety Assessment (BSA) EN 60950-1:2006

A Notified Body statement of opinion for this standard is available on request.

The High-power module with M16 suffix is not approved for use in Europe.

Additionally, both module types have received FCC "Modular Approval", in compliance with CFR 47 FCC part 15 regulations and in accordance to FCC public notice DA00-1407. The modular approvals notice and test reports are available on request.

The JN5179-001-M16 module is subject to user proximity restrictions under FCC regulations; more specific information is available in [Section 13.1.2](#).



## 2. Features and benefits

### 2.1 Benefits

- Microminiature module solutions
- Ready to use in products
- Minimizes product development time
- No RF test required for systems
- Compliant with:
  - ◆ FCC 47CFR Part 15C
  - ◆ ETSI EN 300 328 V1.9
  - ◆ EN 301-489-17 V2.2.1
  - ◆ EN60950-1-2006
  - ◆ Temperature range: -40 °C to +85 °C
  - ◆ Lead-free and RoHS compliant

### 2.2 Features: modules

- 2.4 GHz IEEE 802.15.4, ZigBee Smart Energy and Home Automation compatible
- JN5179-001-M10
  - ◆ Dimensions: 14.5 mm × 20.5 mm
  - ◆ Integrated printed antenna
  - ◆ TX power 8.5 dBm/10 dBm
  - ◆ Receiver sensitivity -96 dBm
  - ◆ TX current 24 mA at 10 dBm
  - ◆ TX current 21.2 mA at 8.5 dBm
  - ◆ RX current 14.3 mA at maximum input level -2 dBm
  - ◆ 2.0 V/3.6 V operation
- JN5179-001-M13
  - ◆ Dimensions: 14.5 mm × 20.5 mm
  - ◆  $\mu$ FI connector
  - ◆ TX power 8.5 dBm/10 dBm
  - ◆ Receiver sensitivity -96 dBm
  - ◆ TX current 24 mA at 10 dBm
  - ◆ TX current 21.2 mA at 8.5 dBm
  - ◆ RX current 14.3 mA at maximum input level -2 dBm
  - ◆ 2.0 V/3.6 V operation
- JN5179-001-M16
  - ◆ Dimensions: 14.5 mm × 20.5 mm
  - ◆ Integrated printed antenna and  $\mu$ FI connector
  - ◆ Antenna diversity
  - ◆ TX power 21 dBm
  - ◆ Receiver sensitivity -100 dBm
  - ◆ TX current 114 mA at 21 dBm
  - ◆ RX current 19 mA at maximum input level -11 dBm

- ◆ 2.0 V/3.6 V operation

### 2.3 Features: microcontroller

- ARM Cortex-M3 CPU with debug support
- 512 kB/32 kB/4 kB (Flash/RAM/EEPROM)
- OTA firmware upgrade capability
- 32 MHz clock selectable down to 1 MHz for low-power operation
- Dual PAN ID support
- Fail-safe I<sup>2</sup>C-bus interface. operates as either master or slave
- 8 × Timers (6 × PWM and 2 timer/counter)
- 2 low-power sleep counters
- 2 × UART, one with flow control
- SPI-bus master and slave port, 2 simultaneous selects
- Variable instruction width for high coding efficiency
- Multi-stage instruction pipeline
- Data EEPROM with guaranteed 100 k write operations
- ZigBee PRO stack with Smart Home, Smart Lighting and Smart Energy profiles
- Supply voltage monitor with 8 programmable thresholds
- Battery voltage and temperature sensors
- 6-input 10-bit ADC
- Analog comparator
- Digital monitor for ADC
- Watchdog timer and POR
- Standby power controller
- Up to 18 Digital IO (DIO) and 2 digital outputs pins

## 3. Applications

- Robust and secure low-power wireless applications
- ZigBee Home Automation networks
- Toys and gaming peripherals
- Energy harvesting - for example, self-powered light switch

## 4. Overview

The JN5179-001-M1x family is a range of ultra-low power, high performance surface mount modules targeted at IEEE 802.15.4, ZigBee Home Automation networking applications, enabling users to realize products with minimum time to market and at the lowest cost. They remove the need for expensive and lengthy development of custom RF board designs and test suites. The modules use NXP's JN5179 wireless microcontroller to provide a comprehensive solution with large memory, high CPU and radio performance and all RF components included. All that is required to develop and manufacture wireless control or sensing products is to connect a power supply and peripherals such as switches, actuators and sensors, considerably simplifying product development.

3 module variants are available: JN5179-001-M10 with an integrated printed antenna, JN5179-001-M13 with a  $\mu$ FL antenna connector and JN5179-001-M16 with a power amplifier, LNA for extended range and antenna diversity, thanks to the integrated antenna and  $\mu$ FL antenna connector.

The dimensions of the 3 module variants are: 14.5 x 20.5 mm.

## 5. Ordering information

**Table 1. Ordering information**

Type number	Description	FCCID
JN5179-001-M10	standard power, integrated printed antenna	XXMJN5179M1X
JN5179-001-M13	standard power, $\mu$ FL antenna connector	XXMJN5179M1X
JN5179-001-M16	high power, LNA, antenna diversity (integrated printed antenna and $\mu$ FL antenna connector)	XXMJN5179M16

## 6. Marking

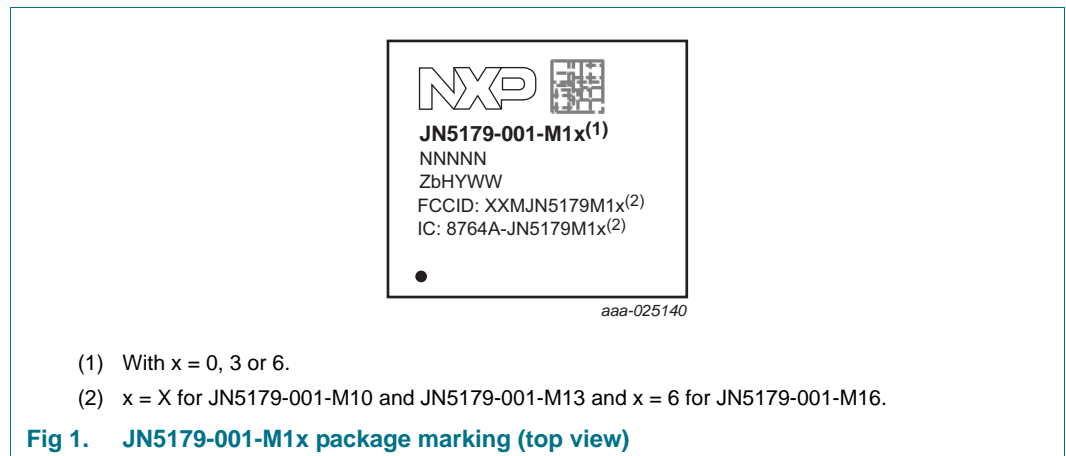

**Table 2. Marking code**

Line number	Marking code
Line 1	NXP Logo: B&W outline logo - 2D barcode (internal NXP usage)
Line 2	part ID: JN5179-001-M1x, with x the module type 0, 3 or 6
Line 3	serial number: NNNNN
Line 4	<ul style="list-style-type: none"> <li>• Z: SSMC</li> <li>• b: SPIL</li> <li>• H: halogen free</li> <li>• Y: year</li> <li>• WW: week code</li> </ul>
Line 5	FFC ID = FCCID: XXMJN5179M1x, with x the module type 0, 3 or 6
Line 6	IC ID = IC: 8764A-JN5179M1x, with x = X for JN5179-001-M10 and JN5179-001-M13 and x = 6 for JN5179-001-M16

JN5179-001-M1x modules meet the requirements of Directive 2002/95/EC of the European Parliament and of the Council on the Restriction of Hazardous Substance (RoHS) and of the Chinese RoHS requirements SJ/T11363-2006 which came into force on 1 March 2007.

## 7. Block diagram

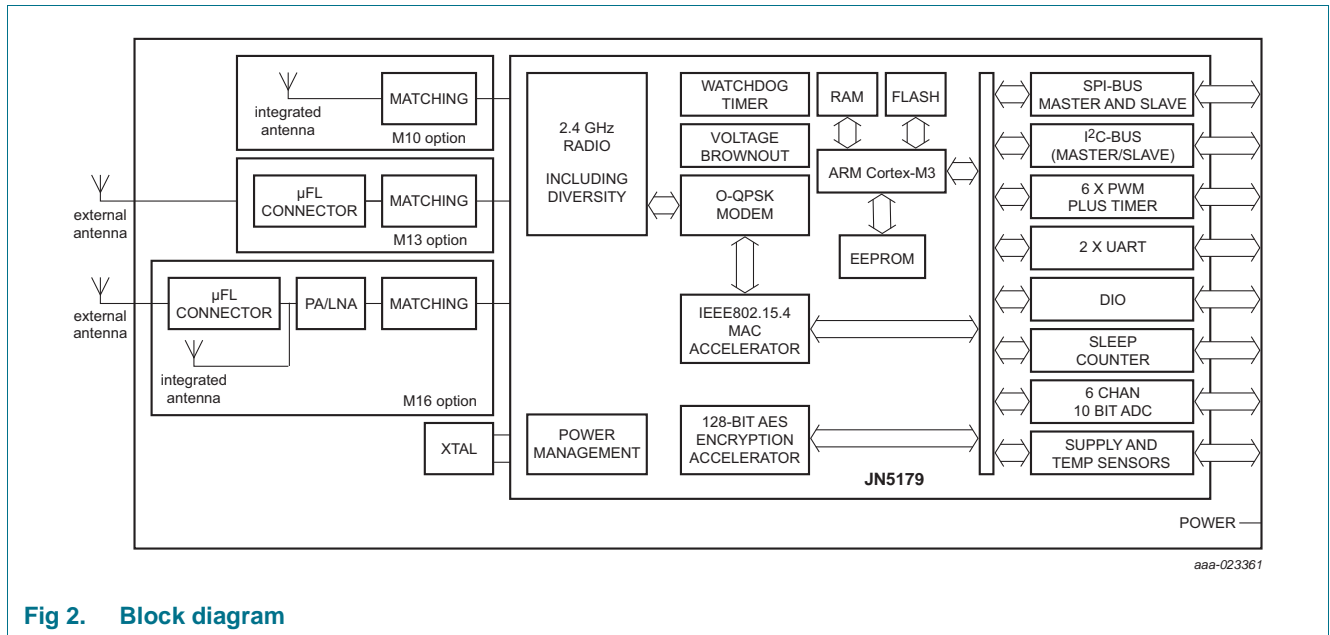
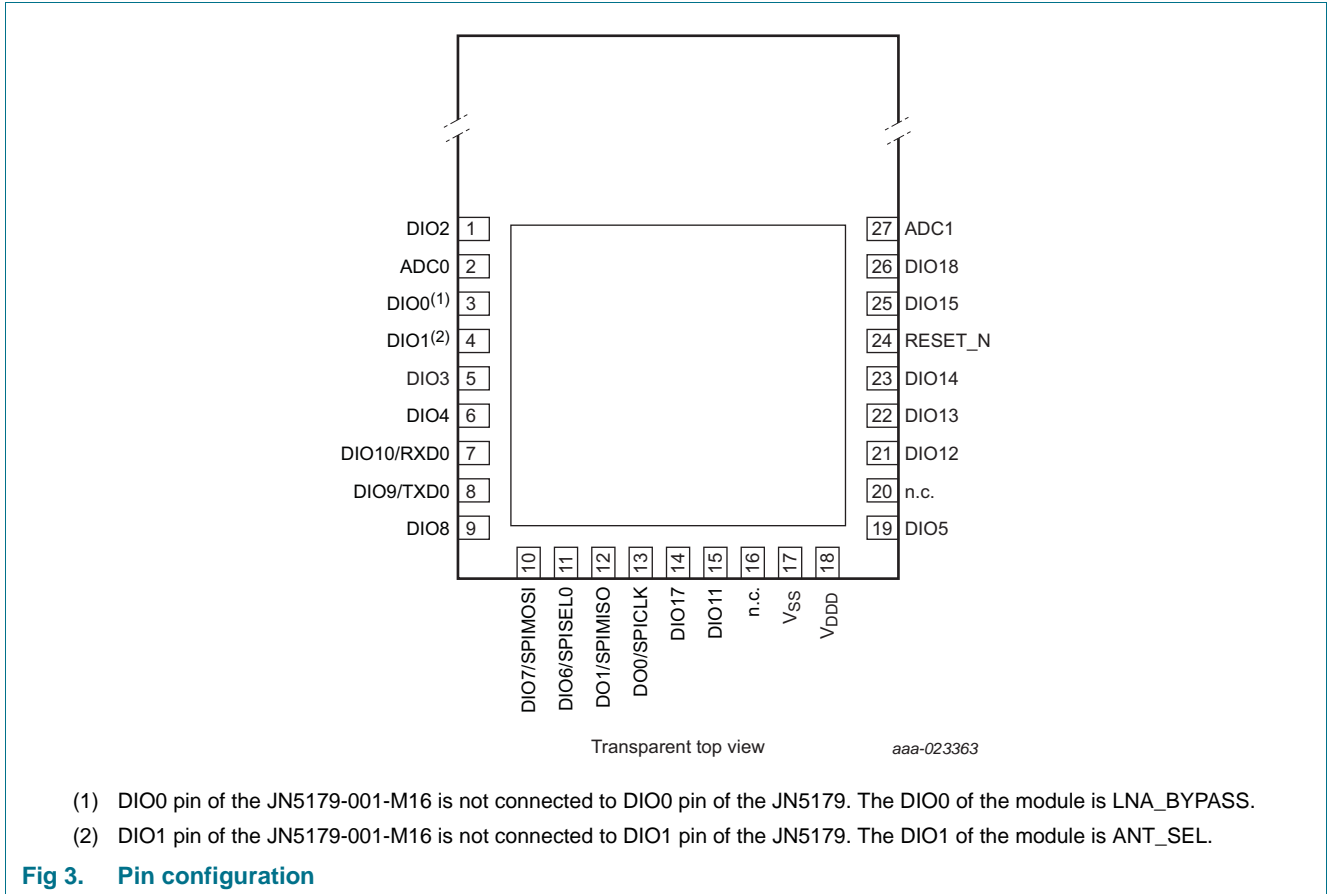

Fig 2. Block diagram

## 8. Pinning information

### 8.1 Pinning



### 8.2 Pin description

Table 3. Pin description

Symbol	Pin	Type <sup>[1]</sup>	Description
DIO2	1	IO	DIO2 — digital input/output 2 ADC5 — ADC input 5 SDA — I <sup>2</sup> C-bus master/slave SDA input/output (push-pull output) RXD1 — UART 1 receive data input TIM0CAP — Timer0 capture input RFRX — radios receiver control output
ADC0	2	I	ADC0 — ADC input 0

Table 3. Pin description ...continued

Symbol	Pin	Type <sup>[1]</sup>	Description
DIO0 <sup>[2]</sup>	3	IO	DIO0 — digital input/output 0
			ADC4 — ADC input 4
			SPISEL0 — SPI-bus master select output 0
			RFRX — radio receiver control output
			FLICK_CTRL — flicker control output
			ADO — antenna diversity odd output
			LNA-BYPASS — LNA bypass on JN5179-001-M16
DIO1 <sup>[2]</sup>	4	IO	DIO1 — digital input/output 1
			ADC3 — ADC input 3
			RFTX — radio transmitter control input
			PC0 — pulse counter 0 input
			ADE — antenna diversity even output
			ANT_SELECT — antenna select on JN5179-001-M16
DIO3	5	IO	DIO3 — digital input/output 3
			ADC2 — ADC input 2
			PWM4 — PWM4 output
			SCL — I <sup>2</sup> C-bus master/slave SCL input/output (push-pull output)
			TXD1 — UART 1 transmit data output
			TIM0OUT — Timer0 output
			RFTX — radio transmit control input
FLICK_CTRL — flicker control output			
DIO4 <sup>[5]</sup>	6	IO	DIO4 — digital input/output 4
			SCL — I <sup>2</sup> C-bus master/slave SCL input/output (open-drain)
			RXD0 — UART 0 receive data input
			TIM0CK_GT — Timer0 clock/gate input
			ADO — antenna diversity odd output
DIO10/RXD0	7	IO	DIO10 — digital input/output 10
			JTAG_TDI — JTAG TDI data input
			RXD0 — UART 0 receive data input
DIO9/TXD0	8	IO	DIO9 — digital input/output 9
			JTAG_TDO — JTAG TDO data output
			TXD0 — UART 0 transmit data output
			TRACESWV — ARM trace serial wire viewer output
DIO8	9	IO	DIO8 — digital input/output 8
			PWM5 — PWM5 output
			TIM0OUT — Timer0 output
			TRACECLK — trace clock output
			32KXTALIN — 32 kHz clock input

Table 3. Pin description ...continued

Symbol	Pin	Type <sup>[1]</sup>	Description
DIO7/SPI MOSI	10	IO	DIO7 — digital input/output 7
			SPI MOSI — SPI-bus master data output
			JTAG_TDI — JTAG TDI data input
			SPI SEL2 — SPI-bus master select output 2
			SPI SSEL — SPI-bus slave select input
			CMP_OUT — comparator output
			32KIN — 32 kHz External clock input
			32KXTALOUT — 32 kHz clock output
DIO6/SPI SEL0	11	IO	DIO6 — digital input/output 6
			SPI SEL0 — SPI-bus master select output 0
			CTS0 — UART 0 clear to send input
			RXD1 — UART 1 receive data input
			JTAG_TCK — JTAG TCK input
			SWCK — Serial Wire Debugger Clock input
			SPI SCLK — SPI-bus slave clock input
			TIM1CAP — Timer1 capture input
DO1/SPI MISO <sup>[3]</sup>	12	IO	DO1 — digital output 1
			SPI MISO — SPI-bus master data input
			SPI SMISO — SPI-bus slave data output
			ADO — antenna diversity odd output
DO0/SPI CLK <sup>[4]</sup>	13	O	DO0 — digital output 0
			SPI CLK — SPI-bus master clock output
			ADE — antenna diversity even output
DIO17	14	IO	DIO17 — digital input/output 17
			JTAG_TCK — JTAG TCK input
			SWCK — Serial Wire Debugger Clock input
			SPI SEL0 — SPI-bus master select output 0
			TIM1CAP — Timer1 capture input
			COMP1P — comparator plus input
			SPI SMISO — SPI-bus slave data output
DIO11	15	IO	DIO11 — digital input/output 11
			JTAG_TMS — JTAG TMS input
			SWD — serial wire debugger input
			RTS0 — UART 0 request to send output
			TXD1 — UART 1 transmit data output
			SPI CLK — SPI-bus master clock output
			SPI SMOSI — SPI-bus slave data input
			TIM1OUT — Timer1 output
			TRACED0 — ARM trace data0 output
n.c.	16	-	not connected; keep floating or ground
V <sub>SS</sub>	17	G	V <sub>SS</sub> — ground



Table 3. Pin description ...continued

Symbol	Pin	Type <sup>[1]</sup>	Description
V <sub>DD</sub>	18	P	V <sub>DD</sub> — digital and analog supply voltage
DIO5 <sup>[5]</sup>	19	IO	DIO5 — digital input/output 5 SDA — I <sup>2</sup> C-bus master/slave SDA input/output (open-drain) TXD0 — UART 0 transmit data output PC1 — pulse counter 1 input TIM0CAP — Timer0 capture input ADE — antenna diversity even output
n.c.	20	-	not connected; keep floating or ground
DIO12	21	IO	DIO12 — digital input/output 12 PWM1 — PWM1 output TXD0 — UART 0 transmit data output TRACED3 — ARM trace data3 output
DIO13	22	IO	DIO13 — digital input/output 13 PWM2 — PWM2 output RXD0 — UART 0 receive data input PC0 — pulse counter 0 input TRACED2 — ARM trace data2 output
DIO14	23	IO	DIO14 — digital input/output 14 PWM3 — PWM3 output PC1 — pulse counter 1 input CMP_OUT — comparator output TRACED1 — ARM trace data1 output SPISMOSI — SPI-bus slave data input
RESET_N	24	I	RESET_N — reset input
DIO15	25	IO	DIO15 — digital input/output 15 PWM6 — PWM6 output JTAG_TDO — JTAG TDO data output SPIMOSI — SPI-bus master data output SPISEL1 — SPI-bus master select output 1 TIM0CK_GT — Timer0 - clock gate input TRACESWV — ARM trace Serial Wire Viewer output SPISSEL — SPI-bus slave select input

**Table 3. Pin description ...continued**

Symbol	Pin	Type <sup>[1]</sup>	Description
DIO18	26	IO	<b>DIO18</b> — digital input/output 18
			<b>JTAG_TMS</b> — JTAG TMS input
			<b>SWD</b> — Serial Wire Debugger input
			<b>SPIMISO</b> — SPI-bus master data input
			<b>TIM1OUT</b> — Timer1 output
			<b>COMP1M</b> — comparator minus input
			<b>SPISCLK</b> — SPI-bus slave clock input
ADC1	27	I	<b>VREF</b> — analog peripheral reference voltage
			<b>ADC1</b> — ADC input 1

- [1] P = power supply; G = ground; I = input, O = output; IO = input/output.
- [2] Not available on the JN5179-001-M16 since they are used to control the front-end module. DIO0 of the module is LNA\_BYPASS and the DIO1 of the module is ANT\_SEL.
- [3] UART programming mode: leave pin floating high during reset to avoid entering UART programming mode or hold it low to program.
- [4] JTAG programming mode: must be left floating high during reset to avoid entering JTAG programming mode.
- [5] Open-drain.

## 9. Functional description

### 9.1 JN5179 single chip wireless microcontroller

The JN5179-001-M1x series is constructed around the JN5179-001 single chip wireless microcontroller, which includes the radio system, an ARM Cortex-M3 CPU, Flash, RAM and EEPROM memory and a range of analog and digital peripherals.

The chip is described fully in JN5179 Wireless Microcontroller Datasheet (see [Ref. 2](#)).

### 9.2 Peripherals

**Table 4. Peripherals description**

Peripherals	JN5179-001-M10	JN5179-001-M13	JN5179-001-M16	Notes
Master SPI-bus port	3 selects	3 selects	3 selects	125 kHz - 16 MHz
Slave SPI-bus port	1	1	1	125 kHz - 4 MHz
UART	2	2	2	16550 compatible
Two-wire serial I/F (compatible with SMBus and I <sup>2</sup> C-bus)	1	1	1	Up to 400 kHz
PWM				16 MHz clock
timer	6	6	6	
timer/counter	2	2	2	
Programmable Sleep Timers	2	2	2	32 kHz clock
Digital IO lines (multiplexed with UARTs, timers and SPI-bus selects)	20	20	18	DIO2 and DIO3 are not available on JN5179-001-M16 modules

Table 4. Peripherals description ...continued

Peripherals	JN5179-001-M10	JN5179-001-M13	JN5179-001-M16	Notes
Analog-to-Digital converter	6	6	6	10 bit, up to 100 ks/s
Programmable analog comparator	1	1	1	ultra low-power mode for sleep
Internal temperature sensor	1	1	1	
Internal battery sensor	1	1	1	

The performance of all peripherals is defined in the JN5179 Wireless Microcontroller Datasheet (see [Ref. 2](#)).

NXP supplies all the development tools and networking stacks needed to enable end-product development to occur quickly and efficiently. These are all freely available from the NXP Wireless Connectivity TechZone (see [Ref. 3](#)). A range of evaluation/developer kits is also available, allowing products to be quickly bread boarded. Efficient development of software applications is enabled by the provision of a complete, unlimited, software developer kit. Together with the available libraries for the IEEE802.15.4 MAC and ZigBee PRO network stacks, this package provides everything required to develop application code and to trial it with hardware representative of the final module.

The modules can be user programmed both in development and in production using software supplied by NXP. Access to the on-chip peripherals, MAC and network stack software is provided through specific APIs. This information is available on the NXP support website, together with many example applications, user guides, reference manuals and application notes.

### 9.3 JN5179-001-M16 Antenna diversity

ANT\_SEL is used to select between the two antennas on the M16 module. Leaving ANT\_SEL unconnected or connecting to V<sub>CC</sub> selects the printed antenna. Tying ANT\_SEL to ground selects the  $\mu$ FL connector. The module can also be used in antenna diversity solutions where the module will automatically swap between the two antennas in order to achieve the best radio performance. This can be done connecting ANT\_SEL to DIO4, DIO5, DO0 or DO1 depend upon your application. The antenna diversity functionality can be enabled by calling vAHI\_AntennaDiversityEnable. The DIO can be selected using vAHI\_SetDIOpinMultiplexValue. Please see JN-UG-3118-JN517x-Integrated-Peripherals-API for more details.

The LNA bypass signal can be used to switch off the LNA in the frontend. This can be useful when in the presence of strong Wifi signals that can overload the frontend. If the pin is left unconnected or tied to V<sub>CC</sub> then the LNA is enabled. If the signal is tied to ground then the LNA will be bypassed during RX. The signal can be connected to a DIO to give software control over the LNA if required.

## 10. Limiting values

**Table 5. Limiting values**

In accordance with the Absolute Maximum Rating System (IEC 60134).

Symbol	Parameter	Conditions	Min	Max	Unit
$V_{DD}$	supply voltage		-0.3	+3.6	V
$V_{ADC0}$	voltage on pin ADC0		-0.3	$V_{DD} + 0.3$ V	V
$V_{ADC1}$	voltage on pin ADC1		-0.3	$V_{DD} + 0.3$ V	V
$V_{IO(dig)}$	digital input/output voltage		-0.3	$V_{DD} + 0.3$ V	V

## 11. Recommended operating conditions

**Table 6. Operating conditions**

Symbol	Parameter	Conditions	Min	Max	Unit
$V_{DD}$	supply voltage	[1]	2	3.6	V
$T_{amb}$	ambient temperature	standard range	-40	+85	°C

[1] To reach the maximum TX power, 2.8 V is the minimum.

## 12. Characteristics

### 12.1 DC current

**Table 7. Active processing**

$V_{DD} = 2$  V to 3.6 V;  $T_{amb} = -40$  °C to +85 °C; CPU running at 16 MHz; unless otherwise specified.

Symbol	Parameter	Conditions	Min	Typ	Max	Unit
$I_{DD}$	supply current	M10				
		radio in receive mode; maximum input level at 10 dBm	-	16.4	-	mA
		radio in receive mode; maximum input level at -2 dBm	-	14.3	-	mA
		radio in transmit mode 10 dBm	[1]	24	-	mA
		radio in transmit mode 8.5 dBm	[1]	21.2	-	mA
		M13				
		radio in receive mode; maximum input level at 10 dBm	-	16.4	-	mA
		radio in receive mode; maximum input level at -2 dBm	-	14.3	-	mA
		radio in transmit mode 10 dBm	[1]	24	-	mA
		radio in transmit mode 8.5 dBm	[1]	21.2	-	mA
		M16				
		radio in receive mode for $\mu$ FI and PCB antenna	-	19	-	mA
		radio in transmit mode for $\mu$ FI	[1]	114	-	mA
		radio in transmit mode for PCB antenna	[1]	78	-	mA

[1] To reach the maximum TX power, 2.8 V is the minimum.

**Table 8. Sleep mode**

$V_{DD} = 2\text{ V to }3.6\text{ V}$ ;  $T_{amb} = -40\text{ °C to }+85\text{ °C}$ ; unless otherwise specified.

Symbol	Parameter	Conditions	Min	Typ	Max	Unit
$I_{DD(IO)}$	input/output supply current	M10 and M13				
		with I/O and RC oscillator timer wake-up; typical values measured at $T_{amb} = 25\text{ °C}$	-	0.61	-	$\mu\text{A}$
		M16				
		with I/O and RC oscillator timer wake-up; typical values measured at $T_{amb} = 25\text{ °C}$	-	0.64	-	$\mu\text{A}$

**Table 9. Deep sleep mode**

$V_{DD} = 2\text{ V to }3.6\text{ V}$ ;  $T_{amb} = -40\text{ °C to }+85\text{ °C}$ ; unless otherwise specified.

Symbol	Parameter	Conditions	Min	Typ	Max	Unit
$I_{DD}$	supply current	typical values measured at $T_{amb} = 25\text{ °C}$ [1] and $V_{DD} = 3.3\text{ V}$	-	100	-	nA

[1] Waiting on chip RESET or I/O event.

## 12.2 AC characteristics

### 12.2.1 Radio transceiver

These modules meet all the requirements of the IEEE802.15.4 standard over 2.0 V to 3.6 V and offers the improved RF characteristics shown in [Table 10](#). All RF characteristics are measured single ended.

**Table 10. RF port characteristics**

Single-ended; Impedance =  $50\ \Omega$  [1];  $V_{DD} = 2\text{ V to }3.6\text{ V}$ ;  $T_{amb} = -40\text{ °C to }+85\text{ °C}$ ; unless otherwise specified.

Symbol	Parameter	Conditions	Min	Typ	Max	Unit
$f_{range}$	frequency range		2.4	-	2.485	GHz

[1] With external matching inductors and assuming PCB layout.

**Table 11. Radio transceiver characteristics: +25 °C**

$V_{DD} = 2\text{ V to }3.6\text{ V}$ ; unless otherwise specified.

Symbol	Parameter	Conditions	Min	Typ	Max	Unit
<b>Receiver</b>						
<b>M10</b>						
$S_{RX}$	receiver sensitivity	nominal for 1 % PER, as per 802.15.4	-	-96	-93.5	dBm
$P_{i(RX)(max)}$	maximum receiver input power	1 % PER, measured as sensitivity; supply current at 14.3 mA	-	-2	-	dBm
$\Delta\alpha_{RSSI}$	RSSI variation	-95 dBm to -10 dBm; available through JN5179-001-M1x Integrated Peripherals API	-4	-	+4	dB
<b>M13</b>						
$S_{RX}$	receiver sensitivity	nominal for 1 % PER, as per 802.15.4	-	-96	-93.5	dBm
$P_{i(RX)(max)}$	maximum receiver input power	1 % PER, measured as sensitivity; supply current at 14.3 mA	-	-2	-	dBm
$\Delta\alpha_{RSSI}$	RSSI variation	-95 dBm to -10 dBm; available through JN5179-001-M1x Integrated Peripherals API	-4	-	+4	dB

**Table 11. Radio transceiver characteristics: +25 °C ...continued**  
*V<sub>DD</sub> = 2 V to 3.6 V; unless otherwise specified.*

Symbol	Parameter	Conditions	Min	Typ	Max	Unit	
<b>M16</b>							
S <sub>RX</sub>	receiver sensitivity	nominal for 1 % PER, as per 802.15.4	-	-100	-98.5	dBm	
P <sub>I(RX)(max)</sub>	maximum receiver input power	1 % PER, measured as sensitivity	-	-11	-	dBm	
Δα <sub>RSSI</sub>	RSSI variation	-100 dBm to -25 dBm; available through JN5179-001-M1x Integrated Peripherals API	-4	-	+4	dB	
<b>Transmitter</b>							
<b>M10</b>							
P <sub>o</sub>	output power	I <sub>DD</sub> = 24 mA	[1]	-	10	-	dBm
		I <sub>DD</sub> = 21.2 mA	[1]	-	8.5	-	dBm
P <sub>o(cr)</sub>	control range output power	in 6 major steps and then 4 fine steps	[2]	-	-42	-	dB
<b>M13</b>							
P <sub>o</sub>	output power	I <sub>DD</sub> = 24 mA	[1]	-	10	-	dBm
		I <sub>DD</sub> = 21.2 mA	[1]	-	8.5	-	dBm
P <sub>o(cr)</sub>	control range output power	in 6 major steps and then 4 fine steps	[2]	-	-42	-	dB
<b>M16</b>							
P <sub>o</sub>	output power	I <sub>DD</sub> = 114 mA	[1]	-	21	-	dBm

[1] To reach the maximum TX power, 2.8 V is the minimum on V<sub>DD</sub>.

[2] Up to an extra 2.5 dB of attenuation is available if required.

## 13. Application information

### 13.1 Federal Communication Commission Interference Statement

This equipment has been tested and found to comply with the limits for a Class B digital device, according to Part 15 of the FCC Rules, see [Ref. 4](#). These limits are designed to provide reasonable protection against harmful interference in a residential installation. This equipment generates, uses, and can radiate radio frequency energy and, if not installed and used in accordance with the instructions, may cause harmful interference to radio communications. However, there is no guarantee that interference will not occur in a particular installation. If this equipment does cause harmful interference to radio or television reception, which can be determined by turning the equipment off and on, the user is encouraged to try to correct the interference by one of the following measures:

- Reorient or relocate the receiving antenna
- Increase the separation between the equipment and receiver
- Connect the equipment into an outlet on a circuit different from that to which the receiver is connected
- Consult the dealer or an experienced radio/TV technician for help

This device complies with Part 15 of the FCC Rules, see [Ref. 4](#). Operation is subject to the following two conditions:

1. This device may not cause harmful interference
2. this device must accept any interference received, including interference that may cause undesired operation

FCC Caution: Any changes or modifications not expressly approved by the party responsible for compliance could void the user's authority to operate this equipment.

**Remark:** FCC Radiation Exposure Statement:

This portable equipment with its antenna complies with FCC's RF radiation exposure limits set forth for an uncontrolled environment. To maintain compliance, follow the instructions below;

1. This transmitter must not be co-located or operating in conjunction with any other antenna or transmitter.
2. Avoid direct contact to the antenna, or keep it to a minimum while using this equipment.

This transmitter module is authorized to be used in other devices only by OEM integrators under the following condition:

The transmitter module must not be co-located with any other antenna or transmitter.

As long as the above condition is met, further transmitter testing will not be required. However, the OEM integrator is still responsible for testing their end product for any additional compliance requirements required with this module installed (for example, digital device emissions, PC peripheral requirements, etc.).

This applies to the JN5179-001-M10 and JN5179-001-M13 devices, the JN5179-001-M16 is a mobile device (see [Section 13.1.2](#)).

### 13.1.1 Antennas approved by FCC for use with JN5179-M01-M0x-2

**Table 12. Antennas description (FCC)**

	Brand	Model Number	Description	Gain (dBi)	Connector type
1	Aveslink Technology, Inc	E-0005-AC	vertical- flying lead	2	RP-SMA
2	Aveslink Technology, Inc	E-2411-GC	vertical - swivel	2	RP-SMA
3	Aveslink Technology, Inc	E-2410-CA	vertical - bulkhead- flying lead	2	μFL
4	Aveslink Technology, Inc	E-2410-HA	vertical- flying lead	2	μFL
5	Aveslink Technology, Inc	E-2410-GC	vertical - swivel	2	RP-SMA
6	Aveslink Technology, Inc	E-2820-CA	vertical - bulkhead- flying lead	2	μFL
7	Aveslink Technology, Inc	E-2820-GC	vertical - swivel	2	RP-SMA
8	Embedded Antenna Design	FBKR35068-RS-KR	vertical - knuckle antenna	2	RP-SMA
9	Nearson	S131CL-L-PX-2450S	vertical - knuckle-flying lead	2	μFL
10	Laird Technologies	WRR2400-IP04	vertical - knuckle-flying lead	1.5	μFL
11	Laird Technologies	WRR2400-RPSMA	vertical - knuckle-flying lead	1.3	RP-SMA
12	Aveslink Technology, Inc	E-6170-DA	Vertical - right angle	1	μFL
13	Laird Technologies	WCR2400-SMRP	Vertical - knuckle antenna	1	RP-SMA

This device has been designed to operate with the antennas listed above, and having a maximum gain of 2 dBi. Alternative vertical antennas may be used provided that the gain does not exceed 2 dBi. Antennas having a gain greater than 2 dBi are strictly prohibited for use with this device.

The required antenna impedance is 50 Ω.

**13.1.2 High-power module usage limitation**

The high-power module variants are classified as ‘mobile’ device pursuant with FCC 2.1091 and must not be used at a distance of < 20 cm (8”) from any people. This applies to the JN5179-001-M16 module type (XXMJN5179M16).

**Remark:** In the event that these conditions cannot be met (for certain configurations or co-location with another transmitter), then the FCC authorization is no longer considered valid and the FCC ID cannot be used on the final product. In these circumstances, the OEM integrator will be responsible for re-evaluating the end product (including the transmitter) and obtaining a separate FCC authorization.

The OEM integrator has to be aware not to provide information to the end user regarding how to install or remove this RF module in the user manual of the end product.

The user manual for the end product must include the following information in a prominent location;

To comply with FCC’s RF radiation exposure requirements, the antenna(s) used for this transmitter must not be co-located or operating in conjunction with any other antenna or transmitter.

**13.1.3 FCC end product labeling**

The final ‘end product’ should be labeled in a visible area with the following:

Contains TX FCC ID: XXMJN5179M1X for the modules JN5179-001-M10 and JN5179-001-M13, XXMJN5179M16 for the module JN5179-001-M16.

**13.2 European R&TTE Directive 1999/5/EC statement**

JN5179-001-M10 and JN5179-001-M13 are compliant with ETSI EN 300 328 V1.9, EMC, EN 301 489-17 v2.1.1 (2009-02) and the Basic Safety Assessment (BSA) EN 60950-1:2006 (2006-06) and are subject to a Notified Body Opinion.

These modules are approved for use with the antennas listed in the following table. The JN5179-001-M16 module is not approved for use in Europe.

Alternative vertical antennas may be used provided that the gain does not exceed 2 dBi.

**Table 13. Antennas description (R&TTE)**

	Brand	Model Number	Description	Gain (dBi)	Connector type
1	Aveslink Technology, Inc	E-0005-AC	vertical- flying lead	2	RP-SMA
2	Aveslink Technology, Inc	E-2411-GC	vertical - swivel	2	RP-SMA
3	Aveslink Technology, Inc	E-2410-CA	vertical - bulkhead- flying lead	2	μFL
4	Aveslink Technology, Inc	E-2410-HA	vertical- flying lead	2	μFL
5	Aveslink Technology, Inc	E-2410-GC	vertical - swivel	2	RP-SMA

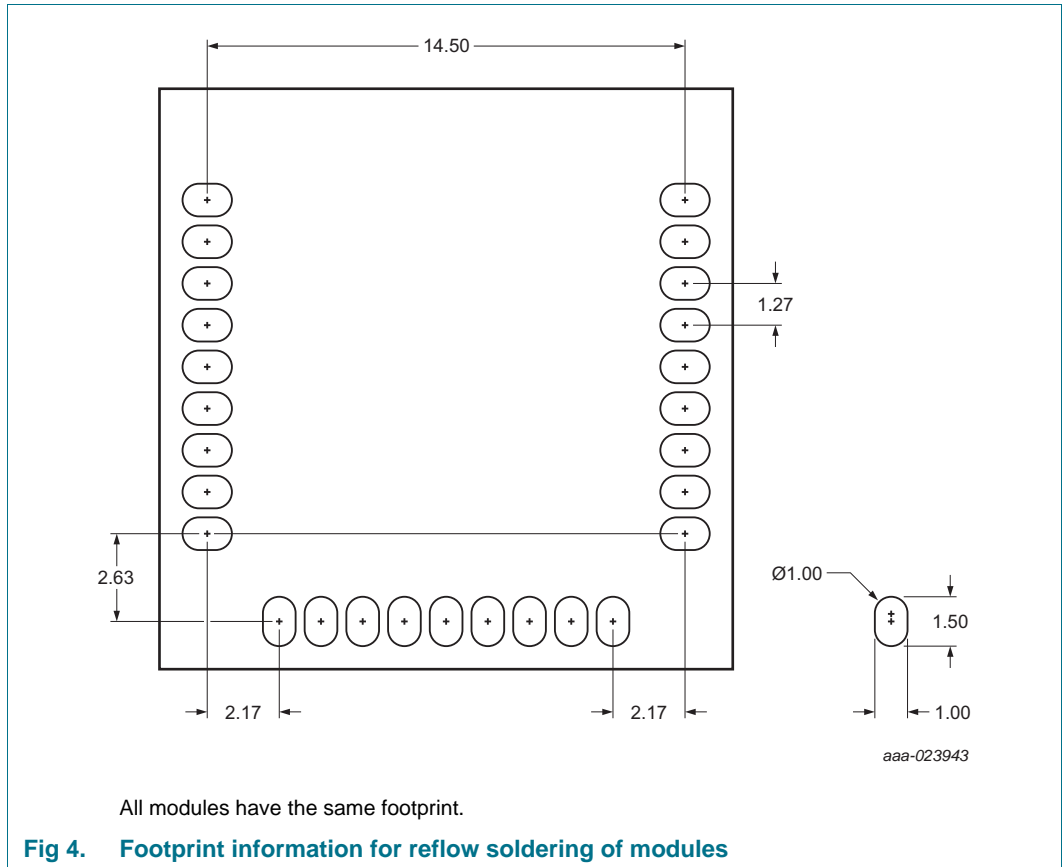

Table 13. Antennas description (R&amp;TTE) ...continued

	Brand	Model Number	Description	Gain (dBi)	Connector type
6	Aveslink Technology, Inc	E-2820-CA	vertical - bulkhead- flying lead	2	μFL
7	Aveslink Technology, Inc	E-2820-GC	vertical - swivel	2	RP-SMA
8	Embedded Antenna Design	FBKR35068-RS-KR	vertical - knuckle antenna	2	RP-SMA
9	Nearson	S131CL-L-PX-2450S	vertical - knuckle-flying lead	2	μFL
10	Laird Technologies	WRR2400-IP04	vertical - knuckle-flying lead	1.5	μFL
11	Laird Technologies	WRR2400-RPSMA	vertical - knuckle-flying lead	1.3	RP-SMA
12	Aveslink Technology, Inc	E-6170-DA	Vertical - right angle	1	μFL
13	Laird Technologies	WCR2400-SMRP	Vertical - knuckle antenna	1	RP-SMA

## 14. Footprint and PCB placement

### 14.1 Footprint information for reflow soldering



### 14.2 Optimal PCB placement of JN5179-001-M10 and JN5179-001-M16 modules

The JN5179-001-M10 and JN5179-001-M16 modules feature an optimised, low-cost, integrated, inverted F, printed PCB antenna. For size reduction no ground plane has been added between the antenna and the JN5179 chip. So an additional ground plane must be added on the main PCB beneath the module in order to ensure a good antenna efficiency. This ground plane can be a rectangle or a square with respect to 2 conditions: it must be as wide as the module (14.5 mm) and the area must be equal or greater than 610 mm<sup>2</sup>. See [Figure 5](#) below for correct placement of the module.

The antenna has a vertically polarised near omnidirectional radiation pattern and up to 1.8 dBi of peak gain. On the antenna side the ground plane of the module must be vertically aligned with the ground plane of the main PCB. The area around the antenna must be kept clear of conductors or other metal objects by a minimum distance of 20 mm except the mandatory ground plane as indicated above. This is true for all layers of the PCB and not just the top layer. Any conductive objects close to the antenna could severely disrupt the antenna pattern resulting in deep nulls and high directivity in some directions.

The [Figure 9](#) show various possible scenarios. The top 3 scenarios are correct - the ground plane must be placed beneath the JN5179-001-M10 or M16 module but it does not protrude beyond the edge of the top layer ground plane on the module PCB.

The bottom four scenarios are incorrect – in the left-hand side there is ground plane underneath the antenna, in the middle-left example the ground planes of the main PCB and the module are not vertically aligned, in the middle-right there is insufficient clearance around the antenna, and in the right-hand example a battery's metal casing is in the recommended 'keep out' area.

These recommendations do not apply to the JN5179-001-M13 module neither to the JN5179-001-M16 applications that use a single external antenna connected to the  $\mu$ FI connector.

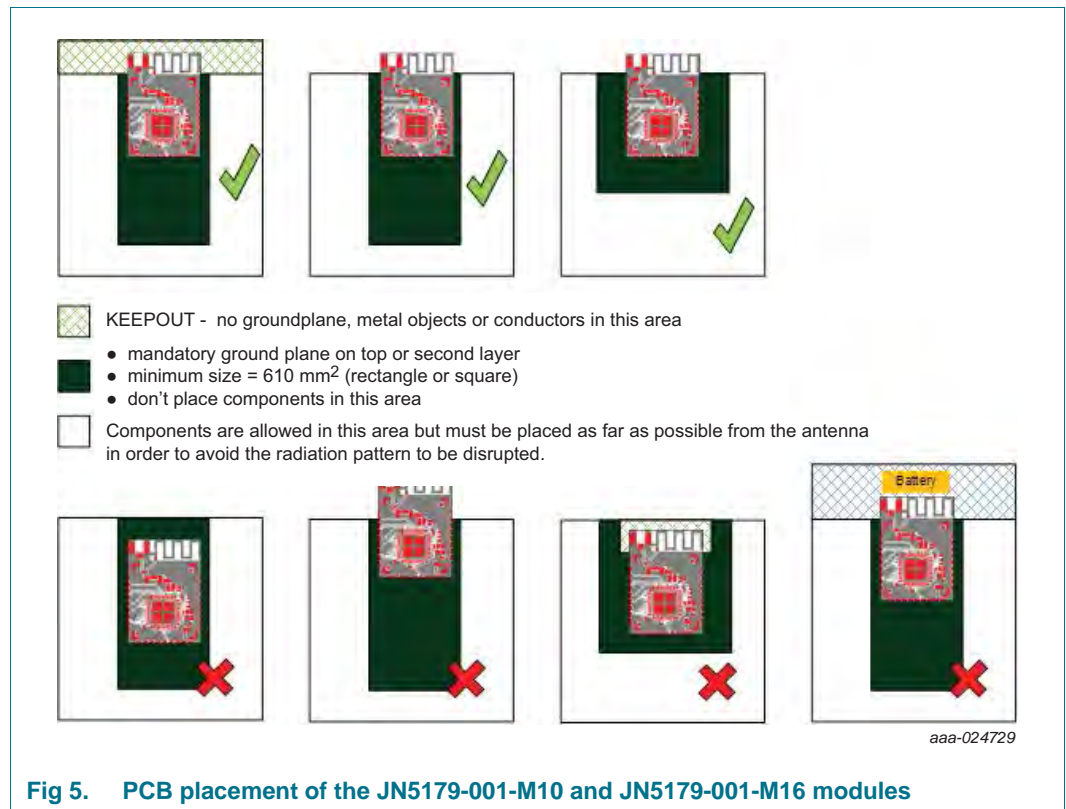

Fig 5. PCB placement of the JN5179-001-M10 and JN5179-001-M16 modules

### 14.3 Reflow Profile

For reflow soldering, it is recommended to follow the reflow profile in [Figure 6](#) as a guide, as well as the paste manufacturer's guidelines on peak flow temperature, soak times, time above liquid and ramp rates.

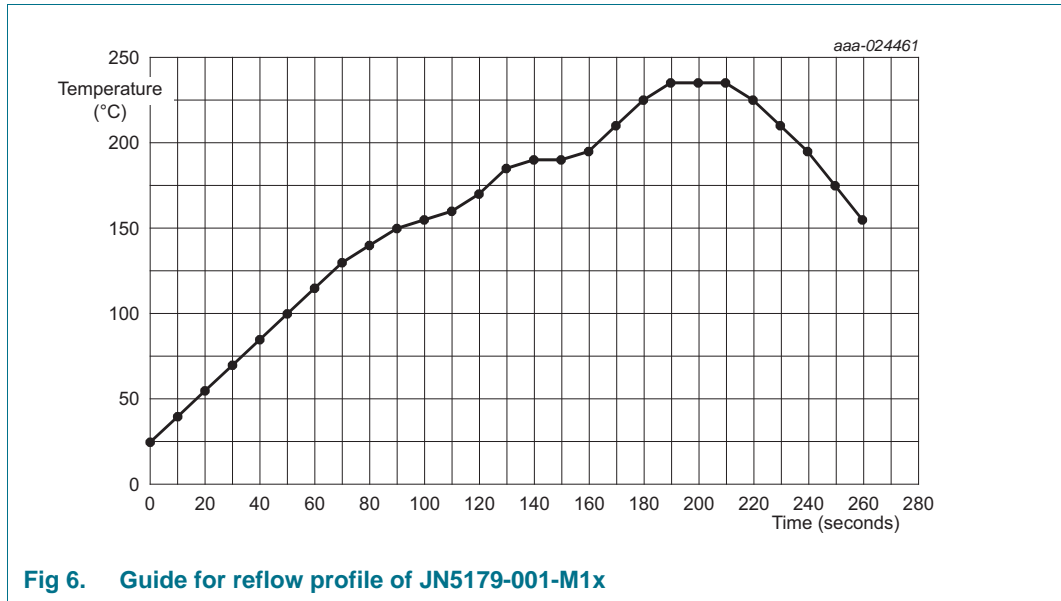

Fig 6. Guide for reflow profile of JN5179-001-M1x

Table 14. Recommended solder reflow profile

Temperature range (°C)	Target time range (s)
from 25 to ~160	between 90 and ~130
from 160 to ~220	between 30 and ~60
from 220 to ~230	between 20 and ~50
from 230 to ~peak	between 10 and ~20
from 25 to ~peak	between 150 and ~260

### 14.4 Soldering paste and cleaning

NXP does not recommend use of a solder paste that requires the module and PCB assembly to be cleaned (rinsed in water) for the following reasons:

- Solder flux residues and water can be trapped by the PCB, can or components and result in short circuits

NXP recommends use of a 'no clean' solder paste for all its module products.

**15. Package outline**

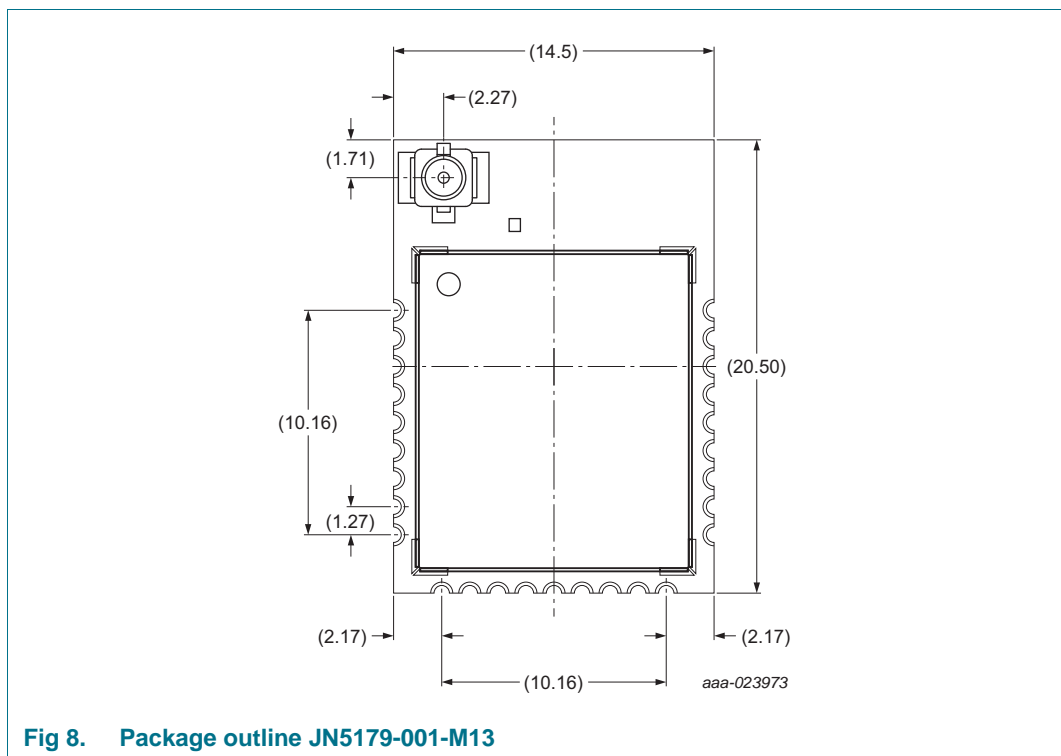
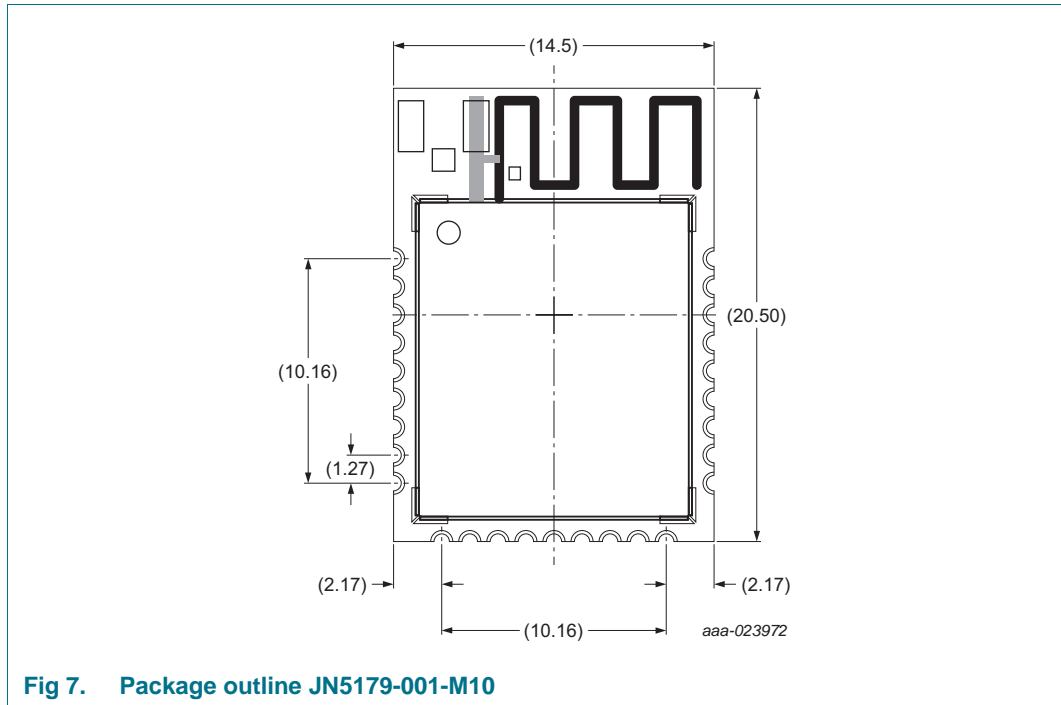

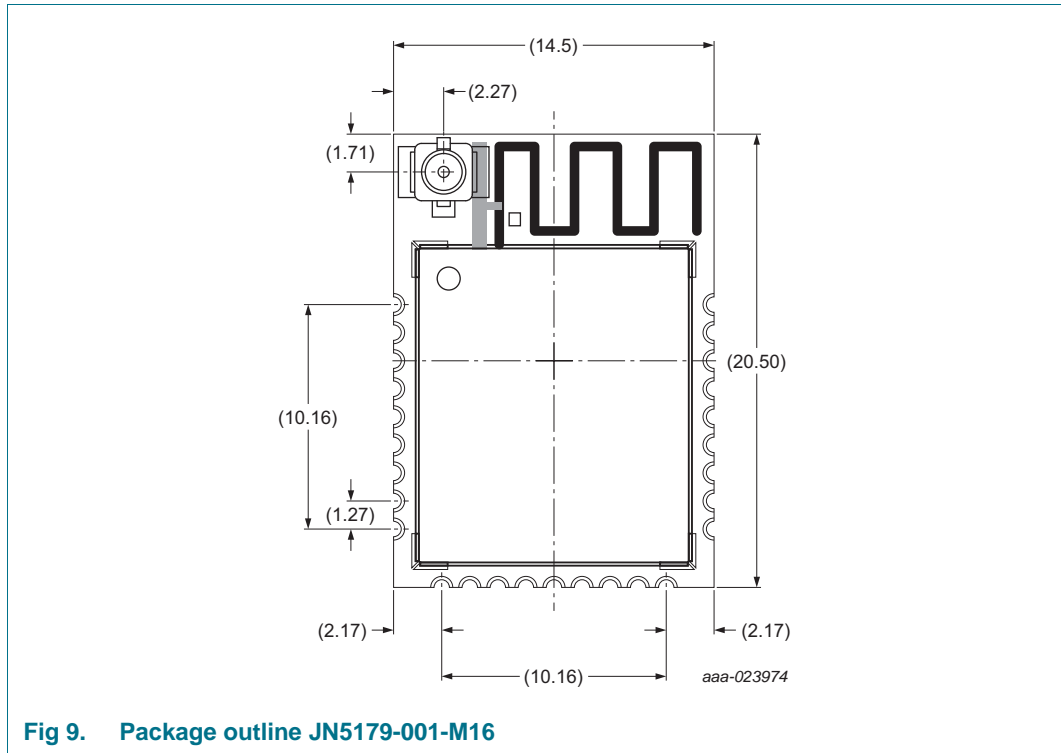

## 16. Abbreviations

**Table 15. Abbreviations**

Acronym	Description
AC	Alternating Current
ADC	Analog-to-Digital Converter
API	Application Program Interface
CE	Conformity European
CPU	Central Processing Unit
DC	Direct Current
DIO	Digital Input Output
EEPROM	Electrically-Erasable Programmable Read-Only Memory
FCC	Federal Communication Commission
ID	IDentification
IO	Input Output
ISM	Industrial, Scientific and Medical radio bands
JTAG	Joint Test Action Group
LNA	Low Noise Amplifier
MAC	Media Access Control
OEM	Original Equipment Manufacturer
PC	Pulse Counter
PCB	Printed-Circuit Board
PER	Packet Error Rate

Table 15. Abbreviations ...continued

Acronym	Description
PRO	PROtocol
PWM	Pulse-Width Modulation
TX	Transmit
R&TTE	Radio And Terminal Telecommunication Equipment
RAM	Random Access Memory
RC	Resistance-Capacitance
RF	Radio Frequency
RISC	Reduced Instruction Set Computing
RoHS	Restriction of Hazardous Substance
RSSI	Received Signal Strength Indicator
RX	Receive
UART	Universal Asynchronous Receiver Transmitter

## 17. References

- [1] **IEEE Std 802.15.4-2011 IEEE Standard for Information Technology Part 15.4** — Wireless Medium Access Control (MAC) and Physical Layer (PHY) Specifications for Low-Rate Wireless Personal Area Networks (LR-WPANs).
- [2] **JN517x** — JN517x wireless microcontroller data sheet.
- [3] **Wireless Connectivity** — <http://www.nxp.com/products/interface-and-connectivity/wireless-connectivity:WIRELESS-CONNECTIVITY>
- [4] **Part 15 of the FCC Rules** — <http://www.ecfr.gov/cgi-bin/text-idx?SID=d01e00935bfc0d53b914e7c8e63f383&node=47:1.0.1.1.16&rgn=div5>

## 18. Revision history

Table 16. Revision history

Document ID	Release date	Data sheet status	Change notice	Supersedes
JN5179-001-M1x v2.0	20161026	Product data sheet	-	JN5179-001-M1x v1.1
Modifications:	<ul style="list-style-type: none"> <li>• Alternative title: updated.</li> <li>• <a href="#">Section 2.1</a>: updated.</li> <li>• <a href="#">Section 2.2</a>: updated.</li> <li>• <a href="#">Section 2.3</a>: updated.</li> <li>• <a href="#">Table 2</a>: updated.</li> <li>• <a href="#">Figure 3</a>: updated.</li> <li>• <a href="#">Table 3</a>: updated.</li> <li>• <a href="#">Table 4</a>: updated.</li> <li>• <a href="#">Section 14.2</a>: added.</li> <li>• <a href="#">Table 7</a>: updated.</li> <li>• <a href="#">Table 8</a>: updated.</li> <li>• <a href="#">Table 9</a>: updated.</li> <li>• <a href="#">Table 11</a>: updated.</li> </ul>			
JN5179-001-M1x v1.1	20160707	Objective data sheet	-	JN5179-001-M1x v1.0
JN5179-001-M1x v1.0	20160707	Objective data sheet	-	-
Modifications:	<ul style="list-style-type: none"> <li>• initial version.</li> </ul>			



## 19. Legal information

### 19.1 Data sheet status

Document status <sup>[1][2]</sup>	Product status <sup>[3]</sup>	Definition
Objective [short] data sheet	Development	This document contains data from the objective specification for product development.
Preliminary [short] data sheet	Qualification	This document contains data from the preliminary specification.
Product [short] data sheet	Production	This document contains the product specification.

[1] Please consult the most recently issued document before initiating or completing a design.

[2] The term 'short data sheet' is explained in section "Definitions".

[3] The product status of device(s) described in this document may have changed since this document was published and may differ in case of multiple devices. The latest product status information is available on the Internet at URL <http://www.nxp.com>.

### 19.2 Definitions

**Draft** — The document is a draft version only. The content is still under internal review and subject to formal approval, which may result in modifications or additions. NXP Semiconductors does not give any representations or warranties as to the accuracy or completeness of information included herein and shall have no liability for the consequences of use of such information.

**Short data sheet** — A short data sheet is an extract from a full data sheet with the same product type number(s) and title. A short data sheet is intended for quick reference only and should not be relied upon to contain detailed and full information. For detailed and full information see the relevant full data sheet, which is available on request via the local NXP Semiconductors sales office. In case of any inconsistency or conflict with the short data sheet, the full data sheet shall prevail.

**Product specification** — The information and data provided in a Product data sheet shall define the specification of the product as agreed between NXP Semiconductors and its customer, unless NXP Semiconductors and customer have explicitly agreed otherwise in writing. In no event however, shall an agreement be valid in which the NXP Semiconductors product is deemed to offer functions and qualities beyond those described in the Product data sheet.

### 19.3 Disclaimers

**Limited warranty and liability** — Information in this document is believed to be accurate and reliable. However, NXP Semiconductors does not give any representations or warranties, expressed or implied, as to the accuracy or completeness of such information and shall have no liability for the consequences of use of such information. NXP Semiconductors takes no responsibility for the content in this document if provided by an information source outside of NXP Semiconductors.

In no event shall NXP Semiconductors be liable for any indirect, incidental, punitive, special or consequential damages (including - without limitation - lost profits, lost savings, business interruption, costs related to the removal or replacement of any products or rework charges) whether or not such damages are based on tort (including negligence), warranty, breach of contract or any other legal theory.

Notwithstanding any damages that customer might incur for any reason whatsoever, NXP Semiconductors' aggregate and cumulative liability towards customer for the products described herein shall be limited in accordance with the *Terms and conditions of commercial sale* of NXP Semiconductors.

**Right to make changes** — NXP Semiconductors reserves the right to make changes to information published in this document, including without limitation specifications and product descriptions, at any time and without notice. This document supersedes and replaces all information supplied prior to the publication hereof.

**Suitability for use** — NXP Semiconductors products are not designed, authorized or warranted to be suitable for use in life support, life-critical or safety-critical systems or equipment, nor in applications where failure or malfunction of an NXP Semiconductors product can reasonably be expected to result in personal injury, death or severe property or environmental damage. NXP Semiconductors and its suppliers accept no liability for inclusion and/or use of NXP Semiconductors products in such equipment or applications and therefore such inclusion and/or use is at the customer's own risk.

**Applications** — Applications that are described herein for any of these products are for illustrative purposes only. NXP Semiconductors makes no representation or warranty that such applications will be suitable for the specified use without further testing or modification.

Customers are responsible for the design and operation of their applications and products using NXP Semiconductors products, and NXP Semiconductors accepts no liability for any assistance with applications or customer product design. It is customer's sole responsibility to determine whether the NXP Semiconductors product is suitable and fit for the customer's applications and products planned, as well as for the planned application and use of customer's third party customer(s). Customers should provide appropriate design and operating safeguards to minimize the risks associated with their applications and products.

NXP Semiconductors does not accept any liability related to any default, damage, costs or problem which is based on any weakness or default in the customer's applications or products, or the application or use by customer's third party customer(s). Customer is responsible for doing all necessary testing for the customer's applications and products using NXP Semiconductors products in order to avoid a default of the applications and the products or of the application or use by customer's third party customer(s). NXP does not accept any liability in this respect.

**Limiting values** — Stress above one or more limiting values (as defined in the Absolute Maximum Ratings System of IEC 60134) will cause permanent damage to the device. Limiting values are stress ratings only and (proper) operation of the device at these or any other conditions above those given in the Recommended operating conditions section (if present) or the Characteristics sections of this document is not warranted. Constant or repeated exposure to limiting values will permanently and irreversibly affect the quality and reliability of the device.

**Terms and conditions of commercial sale** — NXP Semiconductors products are sold subject to the general terms and conditions of commercial sale, as published at <http://www.nxp.com/profile/terms>, unless otherwise agreed in a valid written individual agreement. In case an individual agreement is concluded only the terms and conditions of the respective agreement shall apply. NXP Semiconductors hereby expressly objects to applying the customer's general terms and conditions with regard to the purchase of NXP Semiconductors products by customer.

**No offer to sell or license** — Nothing in this document may be interpreted or construed as an offer to sell products that is open for acceptance or the grant, conveyance or implication of any license under any copyrights, patents or other industrial or intellectual property rights.

**Export control** — This document as well as the item(s) described herein may be subject to export control regulations. Export might require a prior authorization from competent authorities.

**Non-automotive qualified products** — Unless this data sheet expressly states that this specific NXP Semiconductors product is automotive qualified, the product is not suitable for automotive use. It is neither qualified nor tested in accordance with automotive testing or application requirements. NXP Semiconductors accepts no liability for inclusion and/or use of non-automotive qualified products in automotive equipment or applications.

In the event that customer uses the product for design-in and use in automotive applications to automotive specifications and standards, customer (a) shall use the product without NXP Semiconductors' warranty of the product for such automotive applications, use and specifications, and (b) whenever customer uses the product for automotive applications beyond NXP Semiconductors' specifications such use shall be solely at customer's

own risk, and (c) customer fully indemnifies NXP Semiconductors for any liability, damages or failed product claims resulting from customer design and use of the product for automotive applications beyond NXP Semiconductors' standard warranty and NXP Semiconductors' product specifications.

**Translations** — A non-English (translated) version of a document is for reference only. The English version shall prevail in case of any discrepancy between the translated and English versions.

## 19.4 Trademarks

Notice: All referenced brands, product names, service names and trademarks are the property of their respective owners.

**I<sup>2</sup>C-bus** — logo is a trademark of NXP B.V.

## 20. Contact information

---

For more information, please visit: <http://www.nxp.com>

For sales office addresses, please send an email to: [salesaddresses@nxp.com](mailto:salesaddresses@nxp.com)

## 21. Tables

Table 1. Ordering information	4	Table 9. Deep sleep mode	13
Table 2. Marking code	4	Table 10. RF port characteristics	13
Table 3. Pin description	6	Table 11. Radio transceiver characteristics: +25 °C	13
Table 4. Peripherals description	10	Table 12. Antennas description (FCC)	15
Table 5. Limiting values	12	Table 13. Antennas description (R&TTE)	16
Table 6. Operating conditions	12	Table 14. Recommended solder reflow profile	20
Table 7. Active processing	12	Table 15. Abbreviations	22
Table 8. Sleep mode	13	Table 16. Revision history	24

## 22. Figures

Fig 1. JN5179-001-M1x package marking (top view)	4
Fig 2. Block diagram	5
Fig 3. Pin configuration	6
Fig 4. Footprint information for reflow soldering of modules	18
Fig 5. PCB placement of the JN5179-001-M10 and JN5179-001-M16 modules	19
Fig 6. Guide for reflow profile of JN5179-001-M1x	20
Fig 7. Package outline JN5179-001-M10	21
Fig 8. Package outline JN5179-001-M13	21
Fig 9. Package outline JN5179-001-M16	22

## 23. Contents

<b>1</b>	<b>General description</b> . . . . .	<b>1</b>	19.1	Data sheet status . . . . .	25
1.1	Regulatory Approvals . . . . .	1	19.2	Definitions . . . . .	25
<b>2</b>	<b>Features and benefits</b> . . . . .	<b>2</b>	19.3	Disclaimers . . . . .	25
2.1	Benefits . . . . .	2	19.4	Trademarks . . . . .	26
2.2	Features: modules . . . . .	2	<b>20</b>	<b>Contact information</b> . . . . .	<b>26</b>
2.3	Features: microcontroller . . . . .	3	<b>21</b>	<b>Tables</b> . . . . .	<b>27</b>
<b>3</b>	<b>Applications</b> . . . . .	<b>3</b>	<b>22</b>	<b>Figures</b> . . . . .	<b>27</b>
<b>4</b>	<b>Overview</b> . . . . .	<b>3</b>	<b>23</b>	<b>Contents</b> . . . . .	<b>28</b>
<b>5</b>	<b>Ordering information</b> . . . . .	<b>4</b>			
<b>6</b>	<b>Marking</b> . . . . .	<b>4</b>			
<b>7</b>	<b>Block diagram</b> . . . . .	<b>5</b>			
<b>8</b>	<b>Pinning information</b> . . . . .	<b>6</b>			
8.1	Pinning . . . . .	6			
8.2	Pin description . . . . .	6			
<b>9</b>	<b>Functional description</b> . . . . .	<b>10</b>			
9.1	JN5179 single chip wireless microcontroller . . . . .	10			
9.2	Peripherals . . . . .	10			
9.3	JN5179-001-M16 Antenna diversity . . . . .	11			
<b>10</b>	<b>Limiting values</b> . . . . .	<b>12</b>			
<b>11</b>	<b>Recommended operating conditions</b> . . . . .	<b>12</b>			
<b>12</b>	<b>Characteristics</b> . . . . .	<b>12</b>			
12.1	DC current . . . . .	12			
12.2	AC characteristics . . . . .	13			
12.2.1	Radio transceiver . . . . .	13			
<b>13</b>	<b>Application information</b> . . . . .	<b>14</b>			
13.1	Federal Communication Commission Interference Statement . . . . .	14			
13.1.1	Antennas approved by FCC for use with JN5179-M01-M0x-2 . . . . .	15			
13.1.2	High-power module usage limitation . . . . .	16			
13.1.3	FCC end product labeling . . . . .	16			
13.2	European R&TTE Directive 1999/5/EC statement . . . . .	16			
<b>14</b>	<b>Footprint and PCB placement</b> . . . . .	<b>18</b>			
14.1	Footprint information for reflow soldering . . . . .	18			
14.2	Optimal PCB placement of JN5179-001-M10 and JN5179-001-M16 modules . . . . .	18			
14.3	Reflow Profile . . . . .	19			
14.4	Soldering paste and cleaning . . . . .	20			
<b>15</b>	<b>Package outline</b> . . . . .	<b>21</b>			
<b>16</b>	<b>Abbreviations</b> . . . . .	<b>22</b>			
<b>17</b>	<b>References</b> . . . . .	<b>23</b>			
<b>18</b>	<b>Revision history</b> . . . . .	<b>24</b>			
<b>19</b>	<b>Legal information</b> . . . . .	<b>25</b>			

Please be aware that important notices concerning this document and the product(s) described herein, have been included in section 'Legal information'.

© NXP Semiconductors N.V. 2016.

All rights reserved.

For more information, please visit: <http://www.nxp.com>

For sales office addresses, please send an email to: [salesaddresses@nxp.com](mailto:salesaddresses@nxp.com)

Date of release: 26 October 2016

Document identifier: JN5179-001-M1x

## X-ON Electronics

Largest Supplier of Electrical and Electronic Components

*Click to view similar products for [RF Microcontrollers - MCU category](#):*

*Click to view products by [NXP manufacturer](#):*

Other Similar products are found below :

[BCM20704UA1KFFB1G](#) [BCM20733A3KFB1G](#) [BCM20705B0KWFBG](#) [BCM20706UA1KFFB1G](#) [BCM20706UA1KFFB4G](#)  
[BCM20734UA1KFFB3G](#) [BCM20736A1KML2G](#) [CYBL11172-56LQXI](#) [RY7011A0000DZ00#002](#) [CYW20732I](#) [CYW20748A0KFBGT](#)  
[CYW20738A2KML3G](#) [CYW20732E](#) [CYW20702B0KWFBG](#) [BCM20730A1KMLG](#) [JN5164/001,515](#) [CC1310F32RGZR](#) [CC1310F32RSMR](#)  
[PCF7952ATT/M1CC15](#), [ATMEGA64RFR2-ZF](#) [CYW20707UA1KFFB4G](#) [BCM20735PKML1G](#) [JN5168/001,515](#) [STA2058](#)  
[CC1310F128RHBR](#) [ADUCRF101BCPZ128R7](#) [ADUCRF101BCPZ128](#) [ATMEGA1284RFR2-ZU](#) [ATMEGA128RFA1-ZU](#)  
[ATMEGA64RZAV-10MU](#) [CY8C4127LQI-BL483](#) [MAX32666GWP+](#) [CYW20730A2KML2G](#) [ATSAMR21E16A-MU](#) [ATMEGA64RFR2-](#)  
[ZUR](#) [ATMEGA128RFA1-ZUR](#) [RFPIC12F675H-I/SS](#) [JN5169001Z](#) [CYBL11171-56LQXI](#) [CYBL11573-56LQXI](#) [CYBL10161-56LQXI](#)  
[EZR32LG230F64R63G-C0](#) [MKW30Z160VHM4](#) [SI4010-C2-GSR](#) [EZR32LG230F128R55G-B0](#) [EZR32WG330F256R69G-B0](#)  
[EZR32LG330F256R55G-B0](#) [EZR32WG230F128R55G-B0](#) [EZR32WG230F256R55G-B0](#) [EZR32WG330F64R55G-B0](#)