



# K32W041A/K32W041AM

IEEE 802.15.4 and Bluetooth LE 5.0 wireless microcontroller

Rev. 1.1 — June 2021

Objective data sheet

## 1. General description

The K32W041A/K32W041AM are ultra-low power, high performance Arm® Cortex®-M4 based wireless microcontrollers supporting Zigbee 3.0, Thread and Bluetooth Low Energy 5.0 networking stacks to facilitate home and building automation, smart lighting, smart locks and sensor network applications.

The K32W041A/K32W041AM includes a 2.4 GHz Bluetooth Low Energy 5 (supporting eight simultaneous connections) compliant transceiver, a 2.4 GHz IEEE 802.15.4 compliant transceiver and a comprehensive mix of analog and digital peripherals. Ultra-low current consumption in both radio receive and transmit modes and also in the power down modes allow use of coin cell batteries.

The product has 640 KB embedded Flash, 152 KB RAM memory and extend the radio output power to +15dBm. The K32W041AM has an additional 1 MB Data Flash. The embedded flash can support Over The Air (OTA) code download to applications. The devices include a 10-channel PWM, two timers, one RTC/alarm timer, a Windowed Watchdog Timer (WWDT), two USARTs, two SPI interfaces, two I<sup>2</sup>C interfaces, a DMIC subsystem including a dual-channel PDM microphone interface with voice activity detector, one 12-bit ADC, temperature sensor and a comparator.

The Arm Cortex-M4 is a 32-bit core that offers system enhancements such as low power consumption, enhanced debug features, and a high level support of the block integration. The Arm Cortex-M4 CPU, operates at up to 48 MHz.

## 2. Features and benefits

### 2.1 Benefits

- Very low current solution for long battery life
- Single chip device to run stack and application
- System BOM is low in component count and cost
- Flexible sensor interfacing
- Package
  - ◆ 6 × 6 mm HVQFN40, 0.5 mm pitch
  - ◆ Lead-free and RoHS compliant
- Ambient temperature range: -40 °C to +85 °C

### 2.2 Radio features

- 2.4 GHz IEEE 802.15.4 2011 compliant
- 2.4 GHz Bluetooth Low Energy 5.0 compliant

- Receiver current: 7.0 mA
- IEEE 802.15.4 Receiver sensitivity -100 dBm
- Bluetooth Low Energy 5.0 2 Mb/s high data rate
- Bluetooth Low Energy Receiver sensitivity -97 dBm for 1 MB/s
- Improved co-existence with WiFi
- Configurable transmit power up to
  - ◆ +15 dBm, with 46 dB range
- Transmit power / current
  - ◆ +15 dBm / 51 mA
  - ◆ +10 dBm / 26 mA
  - ◆ +3 dBm / 13 mA
  - ◆ +0 dBm / 10.2 mA
- Supply voltage
  - ◆ 2.4 V to 3.6 V
- Antenna Diversity control
- 32 MHz XTAL cell with internal capacitors, able with suitable external XTAL to meet the required accuracy for radio operation over the operating conditions
- Integrated RF balun
- Integrated ultra Low-power sleep oscillator
- Deep Power-down current (with wake-up on IO)
  - ◆ 350 nA (K32W041A)
  - ◆ 360 nA (K32W041AM)
- 128-bit, 192-bit or 256-bit AES security processor
- MAC accelerator with packet formatting, CRCs, address check, auto-acks, timers

## 2.3 Microcontroller features

- Application CPU, Arm Cortex-M4 CPU:
  - ◆ Arm Cortex-M4 processor, running at a frequency of up to 48 MHz.
  - ◆ Arm built-in Nested Vectored Interrupt Controller (NVIC)
  - ◆ Memory Protection Unit (MPU)
  - ◆ Non-maskable Interrupt (NMI) with a selection of sources
  - ◆ Serial Wire Debug (SWD) with 8 breakpoints and 4 watchpoints
  - ◆ System tick timer
  - ◆ Includes Serial Wire Output for enhanced debug capabilities.
- On-Chip memory
  - ◆ 640 KB flash, K32W041AM has an additional 1 MB data flash
  - ◆ 152 KB SRAM
- 12 MHz to 48 MHz system clock speed for low-power
- 2 x I2C-bus interface, operate as either master or slave
- 10 x PWM on K32W041A and 9 x PWM on K32W041AM
- 2 x Low-power timers
- 2 x USART, one with flow control
- 2 x SPI-bus, master or slave

- 1 x PDM digital audio interface with a hardware based voice activity detector to reduce power consumption in voice applications. Support for dual-channel microphone interface, flexible decimators, 16 entry FIFOs and optional DC blocking.
- 19-channel DMA engine for efficient data transfer between peripherals and SRAM, or SRAM to SRAM. DMA can operate with fixed or incrementing addresses. Operations can be chained together to provide complex functionality with low CPU overhead.
- Up to four GPIOs can be selected as pin interrupts (PINT), triggered by rising, falling or both input edges.
- Two GPIO grouped interrupts (GINT) enable an interrupt based on a logical (AND/OR) combination of input states.
- 32-bit Real Time clock (RTC) with 1 s resolution. A timer in the RTC can be used to wake from Sleep, Deep-sleep and Power-down, with 1 ms resolution
- Voltage Brown Out with 8 programmable thresholds
- 8-input (K32W041A) or 5-input (K32W041AM), 12-bit ADC, 190 ksamples/s (Max.). HW support for continuous operation or single conversions, single or multiple inputs can be sampled within a sequence. DMA operation can be linked to achieve low overhead operation.
- 1 x analog comparator, for K32W041AM, only one external input can be used to be compared with the internal reference
- Battery and temperature sensors
- Watchdog timer and POR
- Standby power controller
- Up to 22 (K32W041A) or 18 (K32W041AM) Digital IOs (DIO)
- 1 x Quad SPIFI for accessing:
  - ◆ an external series flash device (K32W041A)
  - ◆ an internal flash device (K32W041AM)
- Random Number Generator engine
- AES engine AES-128 to 256
- Hash hardware accelerator supporting SHA-1 and SHA-256
- EFuse:
  - ◆ 128-bit random AES key
  - ◆ Configuration modes
  - ◆ Trimming
- ISO7816 smart card digital interface which with a suitable external analogue device can operate as a smart card reader

## 2.4 Low power features

- Sleep mode supported, the CPU in low power state waiting for interrupt
- Deep-sleep mode supported, the CPU in low power state waiting for interrupt, but extra functionality disabled or in low power state compared to sleep mode
- Power Down mode, main functionality powered down, wakeup possible from IOs, wakeup possible from some peripherals (I<sup>2</sup>C, USART, SPI) in a limited function mode and low power timers
- Deep -power down, very low power state with option of wake-up triggered by IOs, 350 nA for K32W041A device, or 360 nA for K32W041AM device.

- 41-bit and 28-bit Low power timers can run in power down mode, clocked by 32 kHz FRO or 32 kHz XTAL. Timers can run for over one year or 2 days
- Dedicated low power timer, clocked by 32 kHz XTAL, closely integrated with the Bluetooth Low Energy link layer to maintain the timing reference through power down cycles

### 3. Applications

- Zigbee 3.0, Thread networks
- Bluetooth Low Energy 5.0 networks
- Robust and secure low-power wireless applications
- Smart lighting, door locks, thermostats and home automation
- Wireless sensor networks

### 4. Ordering information

Table 1. Ordering information

Part Number	Package	Flash Size	SRAM Size	1 MB Data Flash	Transmit Power	MPQ
K32W041AZ	40 HVQFN; 6 × 6 × 0.85 mm	640 KB	152 KB	No	+15 dBm	1000 pcs/reel
K32W041AY						4000 pcs/reel
K32W041AK						2450 pcs/5 trays
K32W041AMZ				Yes		1000 pcs/reel
K32W041AMY						4000 pcs/reel
K32W041AMK						2450 pcs/5 trays

### 5. Marking

Table 2. Marking codes

Type number	Marking code
K32W041AZ	32W41A
K32W041AY	
K32W041AK	
K32W041AMZ	32W41AM
K32W041AMY	
K32W041AMK	

## 6. Block diagram

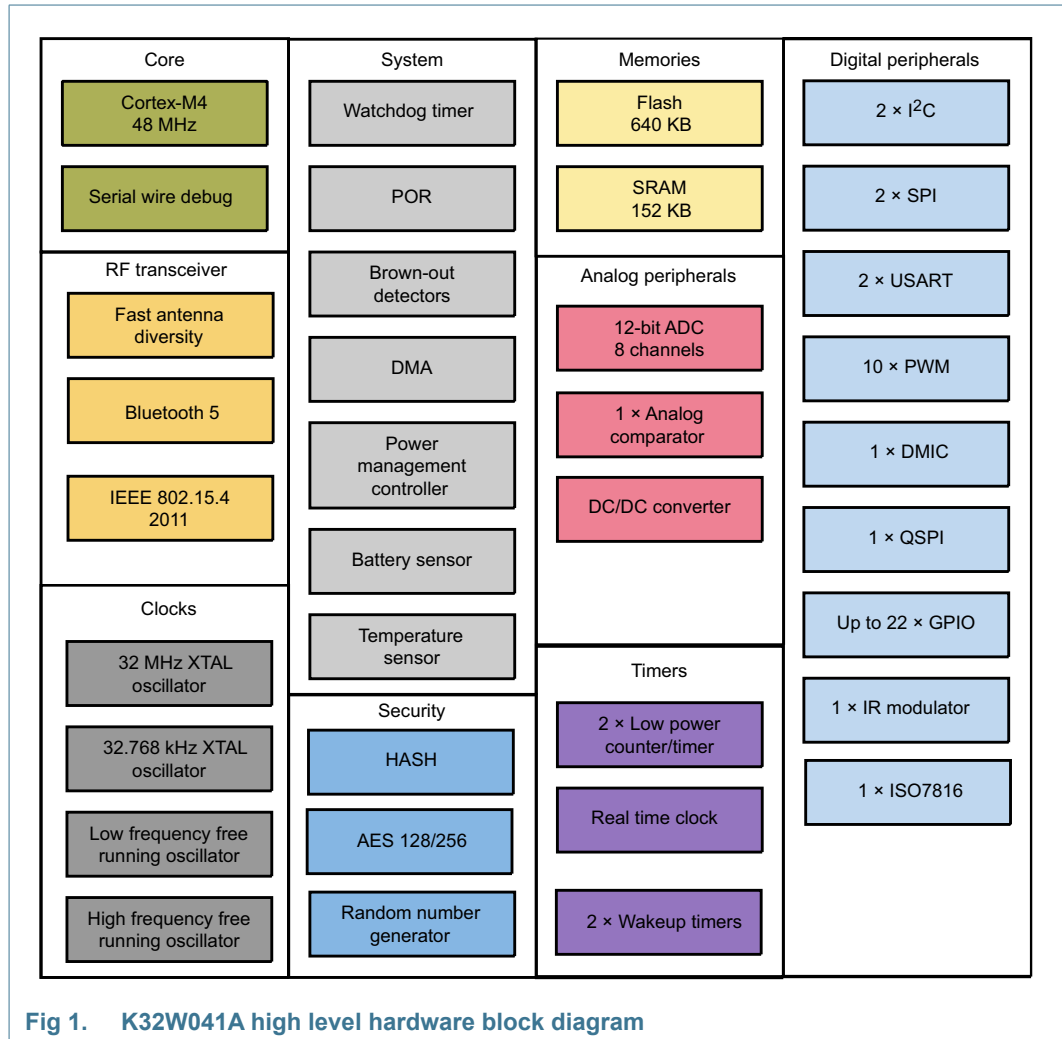

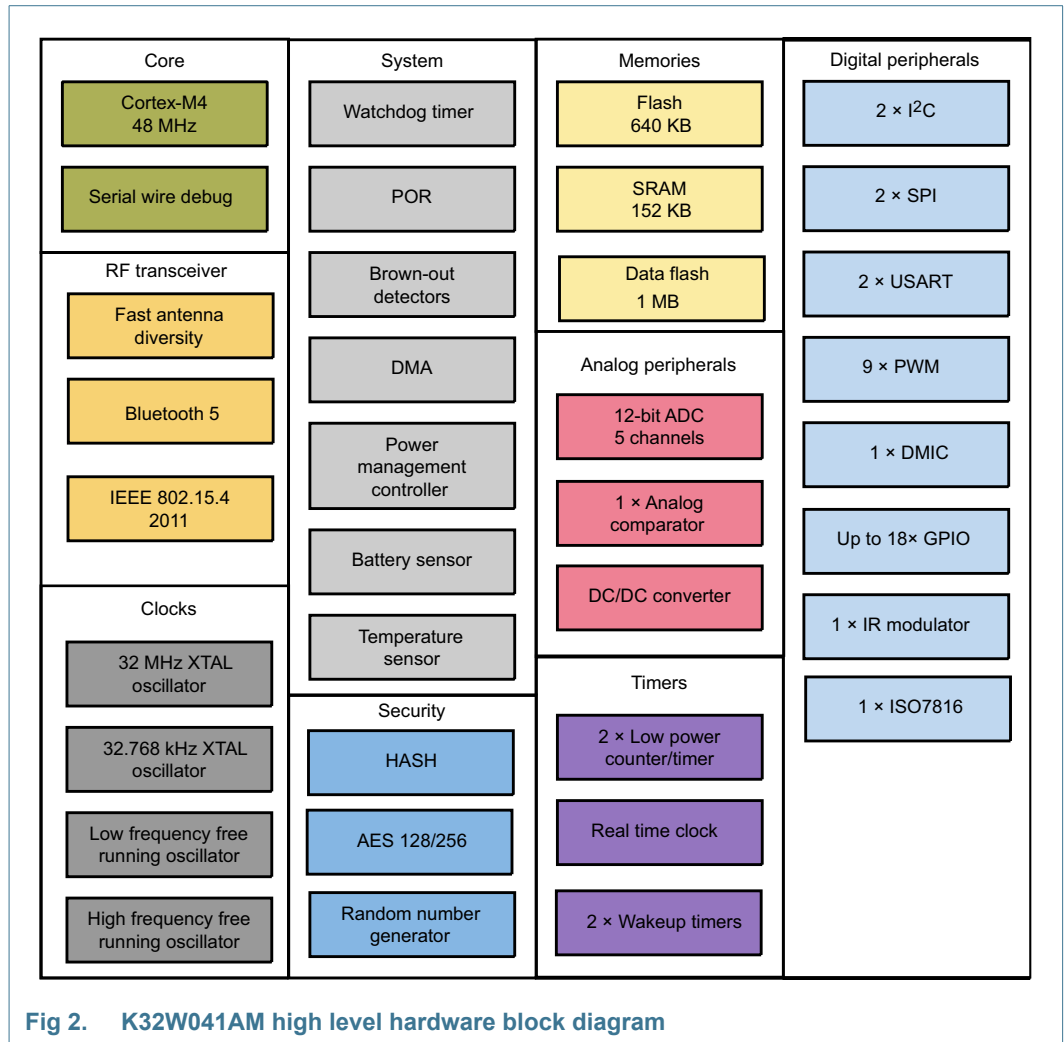
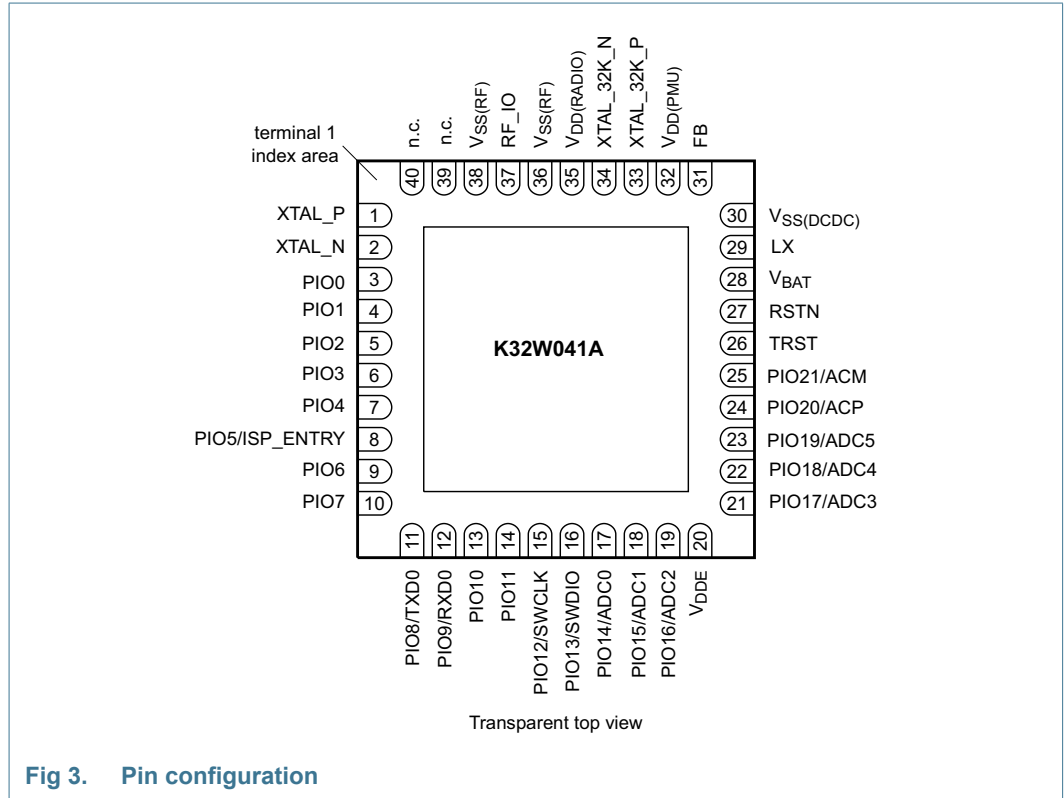

Fig 2. K32W041AM high level hardware block diagram

## 7. Pinning information

### 7.1 K32W041A

#### 7.1.1 Pinning



#### 7.1.2 Pin description

Table 3. Pin descriptions

Symbol	Pin	Type	Default at reset	Description
XTAL_P	1			System crystal oscillator 32 MHz
XTAL_N	2			System crystal oscillator 32 MHz
PIO0	3	IO	GPIO0 <sup>[1]</sup>	<b>GPIO0</b> — General Purpose digital Input/Output 0
				<b>USART0_SCK</b> — Universal Synchronous/Asynchronous Receiver/Transmitter 0 - synchronous clock
				<b>USART1_TXD</b> — Universal Synchronous/Asynchronous Receiver/Transmitter 1 - transmit data output
				<b>PWM0</b> — Pulse Width Modulator output 0
				<b>SPI1_SCK</b> — Serial Peripheral Interface-bus 1 clock input/output
				<b>PDM0_DATA</b> — Pulse Density Modulation Data input from digital microphone (channel 0)

Table 3. Pin descriptions

Symbol	Pin	Type	Default at reset	Description
PIO1	4	IO	GPIO1 <sup>[1]</sup>	<b>GPIO1</b> — General Purpose digital Input/Output 1
				<b>USART1_RXD</b> — Universal Synchronous/Asynchronous Receiver/Transmitter 1 - receive data input
				<b>PWM1</b> — Pulse Width Modulator output 1
				<b>SPI1_MISO</b> — Serial Peripheral Interface-bus 1 master data input
				<b>PDM0_CLK</b> — Pulse Density Modulation Clock output to digital microphone (channel 0)
PIO2	5	IO	GPIO2 <sup>[1]</sup>	<b>GPIO2</b> — General Purpose digital Input/Output 2
				<b>SPI0_SCK</b> — Serial Peripheral Interface-bus 0 clock input/output
				<b>PWM2</b> — Pulse Width Modulator output 2
				<b>SPI1_MOSI</b> — Serial Peripheral Interface-bus 1 master output slave input
				<b>USART0_RXD</b> — Universal Synchronous/Asynchronous Receiver/Transmitter 0 - receive data input
				<b>ISO7816_RST</b> — RST signal, output, for ISO7816 interface
				<b>MCLK</b> — External clock, can be provided to DMIC IP
PIO3	6	IO	GPIO3 <sup>[1]</sup>	<b>GPIO3</b> — General Purpose digital Input/Output 3
				<b>SPI0_MISO</b> — Serial Peripheral Interface-bus 0 master input
				<b>PWM3</b> — Pulse Width Modulator output 3
				<b>SPI1_SSELN0</b> — Serial Peripheral Interface-bus 1 slave select not 0
				<b>USART0_TXD</b> — Universal Synchronous/Asynchronous Receiver/Transmitter 0 - transmit data output
				<b>ISO7816_CLK</b> — Clock output for ISO7816 interface
PIO4	7	IO	GPIO4 <sup>[1][2]</sup>	<b>GPIO4</b> — General Purpose digital Input/Output 4
				<b>SPI0_MOSI</b> — Serial Peripheral Interface-bus 0 master output slave input
				<b>PWM4</b> — Pulse Width Modulator output 4
				<b>SPI1_SSELN1</b> — Serial Peripheral Interface-bus 1 slave select not 1
				<b>USART0_CTS</b> — Universal Synchronous/Asynchronous Receiver/Transmitter 0 - Clear To Send input
				<b>ISO7816_IO</b> — IO of ISO7816 interface
				<b>RFTX</b> — Radio Transmit Control Output
				<b>ISP_SEL</b> — In-System Programming Mode Selection
PIO5/ISP_ENTRY	8	IO	GPIO5/ISP_ENTRY <sup>[1][3]</sup>	<b>GPIO5/ISP_ENTRY</b> — General Purpose digital Input/Output 5; In-System Programming Entry
				<b>SPI0_SSELN</b> — Serial Peripheral Interface-bus 0 slave select not
				<b>SPI1_MISO</b> — Serial Peripheral Interface-bus 1 master data input
				<b>SPI1_SSELN2</b> — Serial Peripheral Interface-bus 1 slave select not 2
				<b>USART0_RTS</b> — Universal Synchronous/Asynchronous Receiver/Transmitter 0 - Request To Send output
				<b>RFRX</b> — Radio Receiver Control Output



Table 3. Pin descriptions

Symbol	Pin	Type	Default at reset	Description
PIO6	9	IO	GPIO6 <sup>[1]</sup>	<b>GPIO6</b> — General Purpose digital Input/Output 6
				<b>USART0_RTS</b> — Universal Synchronous/Asynchronous Receiver/Transmitter 0 - Request to Send output
				<b>CT32B1_MAT0</b> — 32-bit CT32B1 match output 0
				<b>PWM6</b> — Pulse Width Modulator output 6
				<b>I2C1_SCL</b> — I <sup>2</sup> C-bus 1 master/slave SCL input/output
				<b>USART1_TXD</b> — Universal Synchronous/Asynchronous Receiver/Transmitter 1 - transmit data output
				<b>ADE</b> — Antenna Diversity Even output
				<b>SPI0_SCK</b> — Serial Peripheral Interface 0- synchronous clock
PIO7	10	IO	GPIO7 <sup>[1]</sup>	<b>GPIO7</b> — General Purpose digital Input/Output 7
				<b>USART0_CTS</b> — Universal Synchronous/Asynchronous Receiver/Transmitter 0 - Clear to Send input
				<b>CT32B1_MAT1</b> — 32-bit CT32B1 match output 1
				<b>PWM7</b> — Pulse Width Modulator output 7
				<b>I2C1_SDA</b> — I <sup>2</sup> C-bus 1 master/slave SDA input/output
				<b>USART1_RXD</b> — Universal Synchronous/Asynchronous Receiver/Transmitter 1 - receive data input
				<b>ADO</b> — Antenna Diversity Odd Output
				<b>SPI0_MISO</b> — Serial Peripheral Interface-bus 0 master input
PIO8/TXD0	11	IO	GPIO8 <sup>[1][4]</sup>	<b>GPIO8</b> — General Purpose digital Input/Output 8
				<b>USART0_TXD</b> — Universal Synchronous/Asynchronous Receiver/Transmitter 0 - transmit data output
				<b>CT32B0_MAT0</b> — 32-bit CT32B0 match output 0
				<b>PWM8</b> — Pulse Width Modulator output 8
				<b>ANA_COMP_OUT</b> — Analog Comparator digital output
				<b>PDM1_DATA</b> — Pulse Density Modulation Data input from digital microphone (channel 1)
				<b>SPI0_MOSI</b> — Serial Peripheral Interface-bus 0 master output slave input
				<b>RFTX</b> — Radio Transmit Control Output
PIO9/RXD0	12	IO	GPIO9 <sup>[1][5]</sup>	<b>GPIO9</b> — General Purpose digital Input/Output 9
				<b>USART0_RXD</b> — Universal Synchronous/Asynchronous Receiver/Transmitter 0 - receive data input
				<b>CT32B1_CAP1</b> — 32-bit CT32B1 capture input 1
				<b>PWM9</b> — Pulse Width Modulator output 9
				<b>USART1_SCK</b> — Universal Synchronous/Asynchronous Receiver/Transmitter 1 - synchronous clock
				<b>PDM1_CLK</b> — Pulse Density Modulation Clock output to digital microphone (channel 1)
				<b>SPI0_SSELN</b> — Serial Peripheral Interface-bus 0 slave select not
				<b>ADO</b> — Antenna Diversity Odd Output

Table 3. Pin descriptions

Symbol	Pin	Type	Default at reset	Description
PIO10	13	IO	GPIO10 <sup>[1]</sup>	<b>GPIO10</b> — General Purpose digital Input/Output 10
				<b>CT32B0_CAP0</b> — 32-bit CT32B0 capture input 0
				<b>USART1_TXD</b> — Universal Synchronous/Asynchronous Receiver/Transmitter 1 - transmit data output
				<b>RFTX</b> — Radio Transmit Control Output
				<b>I2C0_SCL</b> — I <sup>2</sup> C-bus 0 master/slave SCL input/output (open drain)
				<b>SPI0_SCK</b> — Serial Peripheral Interface-bus 0 clock input/output
				<b>PDM0_DATA</b> — Pulse Density Modulation Data input from digital microphone (channel 0)
PIO11	14	IO	GPIO11 <sup>[1]</sup>	<b>GPIO11</b> — General Purpose digital Input/Output 11
				<b>CT32B1_CAP0</b> — 32-bit CT32B1 capture input 0
				<b>USART1_RXD</b> — Universal Synchronous/Asynchronous Receiver/Transmitter 1 - receive data input
				<b>RFRX</b> — Radio Receiver Control Output
				<b>I2C0_SDA</b> — I <sup>2</sup> C-bus 0 master/slave SDA input/output (open drain)
				<b>SPI0_MISO</b> — Serial Peripheral Interface-bus 0 master input slave output
				<b>PDM0_CLK</b> — Pulse Density Modulation Clock output to digital microphone (channel 0)
PIO12/SWCLK	15	IO	SWCLK	<b>GPIO12</b> — General Purpose digital Input/Output 12
				<b>SWCLK</b> — Serial Wire Debug Clock
				<b>PWM0</b> — Pulse Width Modulator output 0
				<b>I2C1_SCL</b> — I <sup>2</sup> C-bus 1 master/slave SCL input/output (open drain)
				<b>SPI0_MOSI</b> — Serial Peripheral Interface-bus 0 master output slave input
				<b>ANA_COMP_OUT</b> — Analog Comparator digital output
				<b>IR_BLASTER</b> — Infra-Red Modulator output
PIO13/SWDIO	16	IO	SWDIO	<b>GPIO13</b> — General Purpose digital Input/Output 13
				<b>SPI1_SSELN2</b> — Serial Peripheral Interface-bus 1, slave select not 2
				<b>SWDIO</b> — Serial Wire Debug Input/Output
				<b>PWM2</b> — Pulse Width Modulator output 2
				<b>I2C1_SDA</b> — I <sup>2</sup> C-bus 1 master/slave SDA input/output (open drain)
				<b>SPI0_SSELN</b> — Serial Peripheral Interface-bus 0, slave select not

Table 3. Pin descriptions

Symbol	Pin	Type	Default at reset	Description
PIO14/ADC0	17	IO	GPIO14 <sup>[1]</sup>	<b>ADC0</b> — ADC input 0
				<b>GPIO14</b> — General Purpose digital Input/Output 14
				<b>SPI1_SSELN1</b> — Serial Peripheral Interface-bus 1, slave select not 1
				<b>CT32B0_CAP1</b> — 32-bit CT32B0 capture input 1
				<b>PWM1</b> — Pulse Width Modulator output 1
				<b>SWO</b> — Serial Wire Output
				<b>USART0_SCK</b> — Universal Synchronous/Asynchronous Receiver/Transmitter 0 - synchronous clock
				<b>MCLK</b> — External clock, can be provided to DMIC IP
				<b>RFTX</b> — Radio Transmit Control Output
PIO15/ADC1	18	IO	GPIO15 <sup>[1]</sup>	<b>ADC1</b> — ADC input 1
				<b>GPIO15</b> — General Purpose digital Input/Output 15
				<b>SPI1_SCK</b> — Serial Peripheral Interface-bus 1, clock input/output
				<b>ANA_COMP_OUT</b> — Analog Comparator digital output
				<b>PWM3</b> — Pulse Width Modulator output 3
				<b>PDM1_DATA</b> — Pulse Density Modulation Data input from digital microphone (channel 1)
				<b>I2C0_SCL</b> — I2C-bus 0 master/slave SCL input/output (open drain)
				<b>RFRX</b> — Radio Receiver Control Output
PIO16/ADC2	19	IO	GPIO16 <sup>[1]</sup>	<b>ADC2</b> — ADC input 2
				<b>GPIO16</b> — General Purpose digital Input/Output 16
				<b>SPI1_SSELN0</b> — Serial Peripheral Interface-bus 1, slave select not 0
				<b>PWM5</b> — Pulse Width Modulator output 5
				<b>PDM1_CLK</b> — Pulse Density Modulation Clock output to digital microphone (channel 1)
				<b>SPIFI_CSN</b> — Quad-SPI Chip Select Not, output
				<b>ISO7816_RST</b> — RST signal, output, for ISO7816 interface
				<b>I2C0_SDA</b> — I2C-bus 0 master/slave SDA input/output (open drain)
V <sub>DDE</sub>	20	P		<b>V<sub>DDE</sub></b> — Supply voltage for IO
PIO17/ADC3	21	IO	GPIO17 <sup>[1]</sup>	<b>ADC3</b> — ADC input 3
				<b>GPIO17</b> — General Purpose digital Input/Output 17
				<b>SPI1_MOSI</b> — Serial Peripheral Interface-bus 1, master output slave input
				<b>SWO</b> — Serial Wire Output
				<b>PWM6</b> — Pulse Width Modulator output 6
				<b>SPIFI_IO3</b> — Quad-SPI Input/Output 3
				<b>ISO7816_CLK</b> — Clock output for ISO7816 interface
<b>CLK_OUT</b> — Clock out				

Table 3. Pin descriptions

Symbol	Pin	Type	Default at reset	Description
PIO18/ADC4	22	IO	GPIO18 <sup>[1]</sup>	<b>ADC4</b> — ADC input 4
				<b>GPIO18</b> — General Purpose digital Input/Output 18
				<b>SPI1_MISO</b> — Serial Peripheral Interface-bus 1, master data input
				<b>CT32B0_MAT1</b> — 32-bit CT32B0 match output 1
				<b>PWM7</b> — Pulse Width Modulator output 7
				<b>SPIFI_CLK</b> — Quad-SPI Clock output
				<b>ISO7816_IO</b> — IO of ISO7816 interface
				<b>USART0_TXD</b> — Universal Synchronous/Asynchronous Receiver/Transmitter 0 - transmit data output
PIO19/ADC5	23	IO	GPIO19 <sup>[1]</sup>	<b>ADC5</b> — ADC input 5
				<b>GPIO19</b> — General Purpose digital Input/Output 19
				<b>ADO</b> — Antenna Diversity Odd Output
				<b>PWM4</b> — Pulse Width Modulator output 4
				<b>SPIFI_IO0</b> — Quad-SPI Input/Output 0
				<b>USART1_RXD</b> — Universal Synchronous/Asynchronous Receiver/Transmitter 1 - receive data input
				<b>CLK_IN</b> — External clock
				<b>USART0_RXD</b> — Universal Synchronous/Asynchronous Receiver/Transmitter 0 - receive data input
PIO20/ACP	24	IO	GPIO20 <sup>[1]</sup>	<b>ACP</b> — Analog Comparator Positive input
				<b>GPIO20</b> — General Purpose digital Input/Output 20
				<b>IR_BLASTER</b> — Infra-Red Modulator output
				<b>PWM8</b> — Pulse Width Modulator output 8
				<b>RFTX</b> — Radio Transmit Control Output
				<b>SPIFI_IO2</b> — Quad-SPI Input/Output 2
				<b>USART1_TXD</b> — Universal Synchronous/Asynchronous Receiver/Transmitter 1 - transmit data output
PIO21/ACM	25	IO	GPIO21 <sup>[1]</sup>	<b>ACM</b> — Analog Comparator Negative input
				<b>GPIO21</b> — General Purpose digital Input/Output 21
				<b>IR_BLASTER</b> — Infra-Red Modulator output
				<b>PWM9</b> — Pulse Width Modulator output 9
				<b>RFRX</b> — Radio Receiver Control Output
				<b>SWO</b> — Serial Wire Output
				<b>SPIFI_IO1</b> — Quad-SPI Input/Output 1
				<b>USART1_SCK</b> — Universal Synchronous/Asynchronous Receiver/Transmitter 1 - synchronous clock
TRST	26	G		<b>TRST</b> — must be connected to GND
RSTN	27	I		<b>RSTN</b> — Reset Not input
V <sub>BAT</sub>	28	P		<b>V<sub>BAT</sub></b> — Supply voltage DCDC input
LX	29			<b>LX</b> — DCDC filter
V <sub>SS(DCDC)</sub>	30	G		<b>V<sub>SS(DCDC)</sub></b> — ground for DCDC section
FB	31			<b>FB</b> — DCDC Feedback input

Table 3. Pin descriptions

Symbol	Pin	Type	Default at reset	Description
V <sub>DD(PMU)</sub>	32	P		<b>V<sub>DD(PMU)</sub></b> — supply voltage for PMU section
XTAL_32K_P	33			crystal oscillator 32.768 kHz
XTAL_32K_N	34			crystal oscillator 32.768 kHz
V <sub>DD(RADIO)</sub>	35	P		<b>V<sub>DD(RADIO)</sub></b> — supply voltage for radio section
V <sub>SS(RF)</sub>	36	G		<b>V<sub>SS(RF)</sub></b> — RF ground
RF_IO	37	IO		<b>RF_IO</b> — RF antenna, RF pin which can be considered as RF Input/output. The radio transceiver is connected here.
V <sub>SS(RF)</sub>	38	G		<b>V<sub>SS(RF)</sub></b> — RF ground
n.c.	39			not connected
n.c.	40			not connected
exposed die pad		G		must be connected to RF ground plane

- [1] I: input at reset.
- [2] For standard operation (normal boot or ISP programming mode), this pin should be high during the release of reset. If there is no external driver to this pin, then the internal pull-up will keep this pin high.
- [3] ISP programming mode: leave pin floating high during reset to avoid entering UART programming mode or hold it low to program.
- [4] In ISP mode, it is configured to USART0\_TXD.
- [5] In ISP mode, it is configured to USART0\_RXD.

## 7.2 K32W041AM

### 7.2.1 Pinning

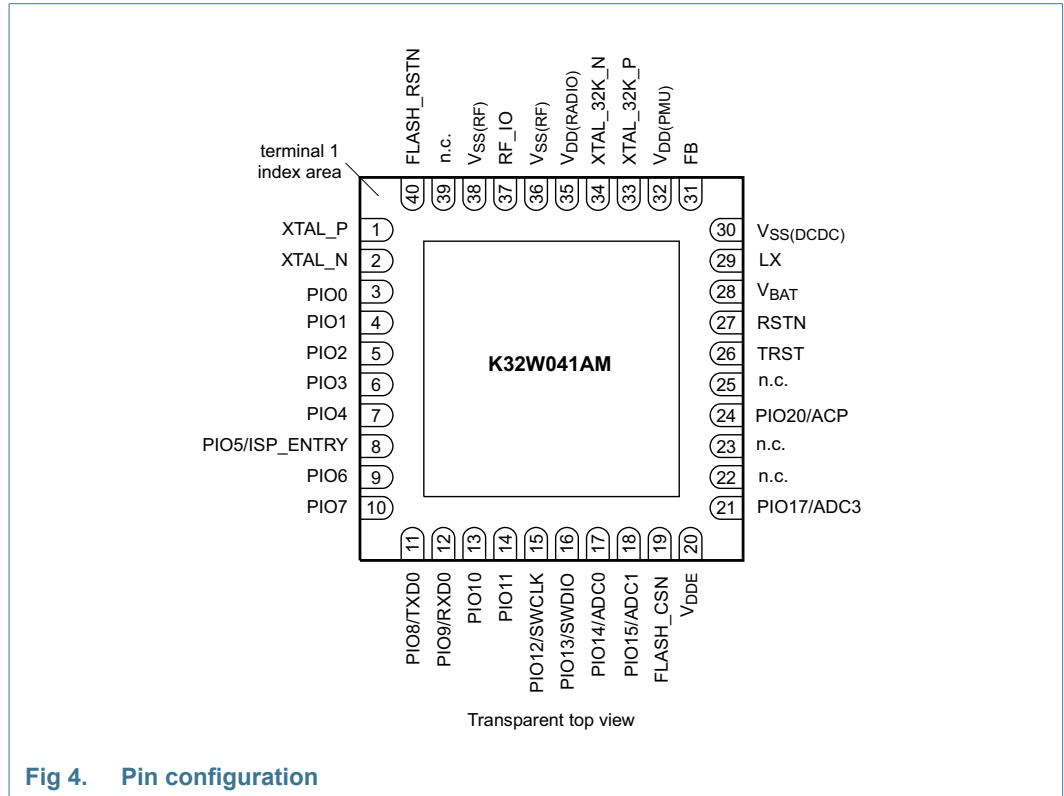

### 7.2.2 Pin description

Table 4. Pin descriptions

Symbol	Pin	Type	Default at reset	Description
XTAL_P	1			System crystal oscillator 32 MHz
XTAL_N	2			System crystal oscillator 32 MHz
PIO0	3	IO	GPIO0 <sup>[1]</sup>	<p><b>GPIO0</b> — General Purpose digital Input/Output 0</p> <p><b>USART0_SCK</b> — Universal Synchronous/Asynchronous Receiver/Transmitter 0 - synchronous clock</p> <p><b>USART1_TXD</b> — Universal Synchronous/Asynchronous Receiver/Transmitter 1 - transmit data output</p> <p><b>PWM0</b> — Pulse Width Modulator output 0</p> <p><b>SPI1_SCK</b> — Serial Peripheral Interface-bus 1 clock input/output</p> <p><b>PDM0_DATA</b> — Pulse Density Modulation Data input from digital microphone (channel 0)</p>

Table 4. Pin descriptions

Symbol	Pin	Type	Default at reset	Description
PIO1	4	IO	GPIO1 <sup>[1]</sup>	<b>GPIO1</b> — General Purpose digital Input/Output 1
				<b>USART1_RXD</b> — Universal Synchronous/Asynchronous Receiver/Transmitter 1 - receive data input
				<b>PWM1</b> — Pulse Width Modulator output 1
				<b>SPI1_MISO</b> — Serial Peripheral Interface-bus 1 master data input
				<b>PDM0_CLK</b> — Pulse Density Modulation Clock output to digital microphone (channel 0)
PIO2	5	IO	GPIO2 <sup>[1]</sup>	<b>GPIO2</b> — General Purpose digital Input/Output 2
				<b>SPI0_SCK</b> — Serial Peripheral Interface-bus 0 clock input/output
				<b>PWM2</b> — Pulse Width Modulator output 2
				<b>SPI1_MOSI</b> — Serial Peripheral Interface-bus 1 master output slave input
				<b>USART0_RXD</b> — Universal Synchronous/Asynchronous Receiver/Transmitter 0 - receive data input
				<b>ISO7816_RST</b> — RST signal, output, for ISO7816 interface
				<b>MCLK</b> — External clock, can be provided to DMIC IP
PIO3	6	IO	GPIO3 <sup>[1]</sup>	<b>GPIO3</b> — General Purpose digital Input/Output 3
				<b>SPI0_MISO</b> — Serial Peripheral Interface-bus 0 master input
				<b>PWM3</b> — Pulse Width Modulator output 3
				<b>SPI1_SSELN0</b> — Serial Peripheral Interface-bus 1 slave select not 0
				<b>USART0_TXD</b> — Universal Synchronous/Asynchronous Receiver/Transmitter 0 - transmit data output
				<b>ISO7816_CLK</b> — Clock output for ISO7816 interface
PIO4	7	IO	GPIO4 <sup>[1][2]</sup>	<b>GPIO4</b> — General Purpose digital Input/Output 4
				<b>SPI0_MOSI</b> — Serial Peripheral Interface-bus 0 master output slave input
				<b>PWM4</b> — Pulse Width Modulator output 4
				<b>SPI1_SSELN1</b> — Serial Peripheral Interface-bus 1 slave select not 1
				<b>USART0_CTS</b> — Universal Synchronous/Asynchronous Receiver/Transmitter 0 - Clear To Send input
				<b>ISO7816_IO</b> — IO of ISO7816 interface
				<b>RFTX</b> — Radio Transmit Control Output
				<b>ISP_SEL</b> — In-System Programming Mode Selection
PIO5/ISP_ENTRY	8	IO	GPIO5/ISP_ENTRY <sup>[1][3]</sup>	<b>GPIO5/ISP_ENTRY</b> — General Purpose digital Input/Output 5; In-System Programming Entry
				<b>SPI0_SSELN</b> — Serial Peripheral Interface-bus 0 slave select not
				<b>SPI1_MISO</b> — Serial Peripheral Interface-bus 1 master data input
				<b>SPI1_SSELN2</b> — Serial Peripheral Interface-bus 1 slave select not 2
				<b>USART0_RTS</b> — Universal Synchronous/Asynchronous Receiver/Transmitter 0 - Request To Send output
				<b>RFRX</b> — Radio Receiver Control Output

Table 4. Pin descriptions

Symbol	Pin	Type	Default at reset	Description
PIO6	9	IO	GPIO6 <sup>[1]</sup>	<b>GPIO6</b> — General Purpose digital Input/Output 6
				<b>USART0_RTS</b> — Universal Synchronous/Asynchronous Receiver/Transmitter 0 - Request to Send output
				<b>CT32B1_MAT0</b> — 32-bit CT32B1 match output 0
				<b>PWM6</b> — Pulse Width Modulator output 6
				<b>I2C1_SCL</b> — I <sup>2</sup> C-bus 1 master/slave SCL input/output
				<b>USART1_TXD</b> — Universal Synchronous/Asynchronous Receiver/Transmitter 1 - transmit data output
				<b>ADE</b> — Antenna Diversity Even output
				<b>SPI0_SCK</b> — Serial Peripheral Interface 0- synchronous clock
PIO7	10	IO	GPIO7 <sup>[1]</sup>	<b>GPIO7</b> — General Purpose digital Input/Output 7
				<b>USART0_CTS</b> — Universal Synchronous/Asynchronous Receiver/Transmitter 0 - Clear to Send input
				<b>CT32B1_MAT1</b> — 32-bit CT32B1 match output 1
				<b>PWM7</b> — Pulse Width Modulator output 7
				<b>I2C1_SDA</b> — I <sup>2</sup> C-bus 1 master/slave SDA input/output
				<b>USART1_RXD</b> — Universal Synchronous/Asynchronous Receiver/Transmitter 1 - receive data input
				<b>ADO</b> — Antenna Diversity Odd Output
				<b>SPI0_MISO</b> — Serial Peripheral Interface-bus 0 master input
PIO8/TXD0	11	IO	GPIO8 <sup>[1][4]</sup>	<b>GPIO8</b> — General Purpose digital Input/Output 8
				<b>USART0_TXD</b> — Universal Synchronous/Asynchronous Receiver/Transmitter 0 - transmit data output
				<b>CT32B0_MAT0</b> — 32-bit CT32B0 match output 0
				<b>PWM8</b> — Pulse Width Modulator output 8
				<b>ANA_COMP_OUT</b> — Analog Comparator digital output
				<b>PDM1_DATA</b> — Pulse Density Modulation Data input from digital microphone (channel 1)
				<b>SPI0_MOSI</b> — Serial Peripheral Interface-bus 0 master output slave input
				<b>RFTX</b> — Radio Transmit Control Output
PIO9/RXD0	12	IO	GPIO9 <sup>[1][5]</sup>	<b>GPIO9</b> — General Purpose digital Input/Output 9
				<b>USART0_RXD</b> — Universal Synchronous/Asynchronous Receiver/Transmitter 0 - receive data input
				<b>CT32B1_CAP1</b> — 32-bit CT32B1 capture input 1
				<b>PWM9</b> — Pulse Width Modulator output 9
				<b>USART1_SCK</b> — Universal Synchronous/Asynchronous Receiver/Transmitter 1 - synchronous clock
				<b>PDM1_CLK</b> — Pulse Density Modulation Clock output to digital microphone (channel 1)
				<b>SPI0_SSELN</b> — Serial Peripheral Interface-bus 0 slave select not
				<b>ADO</b> — Antenna Diversity Odd Output



Table 4. Pin descriptions

Symbol	Pin	Type	Default at reset	Description
PIO10	13	IO	GPIO10 <sup>[1]</sup>	<b>GPIO10</b> — General Purpose digital Input/Output 10
				<b>CT32B0_CAP0</b> — 32-bit CT32B0 capture input 0
				<b>USART1_TXD</b> — Universal Synchronous/Asynchronous Receiver/Transmitter 1 - transmit data output
				<b>RFTX</b> — Radio Transmit Control Output
				<b>I2C0_SCL</b> — I <sup>2</sup> C-bus 0 master/slave SCL input/output (open drain)
				<b>SPI0_SCK</b> — Serial Peripheral Interface-bus 0 clock input/output
				<b>PDM0_DATA</b> — Pulse Density Modulation Data input from digital microphone (channel 0)
PIO11	14	IO	GPIO11 <sup>[1]</sup>	<b>GPIO11</b> — General Purpose digital Input/Output 11
				<b>CT32B1_CAP0</b> — 32-bit CT32B1 capture input 0
				<b>USART1_RXD</b> — Universal Synchronous/Asynchronous Receiver/Transmitter 1 - receive data input
				<b>RFRX</b> — Radio Receiver Control Output
				<b>I2C0_SDA</b> — I <sup>2</sup> C-bus 0 master/slave SDA input/output (open drain)
				<b>SPI0_MISO</b> — Serial Peripheral Interface-bus 0 master input slave output
				<b>PDM0_CLK</b> — Pulse Density Modulation Clock output to digital microphone (channel 0)
PIO12/SWCLK	15	IO	SWCLK	<b>GPIO12</b> — General Purpose digital Input/Output 12
				<b>SWCLK</b> — Serial Wire Debug Clock
				<b>PWM0</b> — Pulse Width Modulator output 0
				<b>I2C1_SCL</b> — I <sup>2</sup> C-bus 1 master/slave SCL input/output (open drain)
				<b>SPI0_MOSI</b> — Serial Peripheral Interface-bus 0 master output slave input
				<b>ANA_COMP_OUT</b> — Analog Comparator digital output
				<b>IR_BLASTER</b> — Infra-Red Modulator output
PIO13/SWDIO	16	IO	SWDIO	<b>GPIO13</b> — General Purpose digital Input/Output 13
				<b>SPI1_SSELN2</b> — Serial Peripheral Interface-bus 1, slave select not 2
				<b>SWDIO</b> — Serial Wire Debug Input/Output
				<b>PWM2</b> — Pulse Width Modulator output 2
				<b>I2C1_SDA</b> — I <sup>2</sup> C-bus 1 master/slave SDA input/output (open drain)
				<b>SPI0_SSELN</b> — Serial Peripheral Interface-bus 0, slave select not

Table 4. Pin descriptions

Symbol	Pin	Type	Default at reset	Description
PIO14/ADC0	17	IO	GPIO14 <sup>[1]</sup>	<b>ADC0</b> — ADC input 0
				<b>GPIO14</b> — General Purpose digital Input/Output 14
				<b>SPI1_SSELN1</b> — Serial Peripheral Interface-bus 1, slave select not 1
				<b>CT32B0_CAP1</b> — 32-bit CT32B0 capture input 1
				<b>PWM1</b> — Pulse Width Modulator output 1
				<b>SWO</b> — Serial Wire Output
				<b>USART0_SCK</b> — Universal Synchronous/Asynchronous Receiver/Transmitter 0 - synchronous clock
				<b>MCLK</b> — External clock, can be provided to DMIC IP
				<b>RFTX</b> — Radio Transmit Control Output
PIO15/ADC1	18	IO	GPIO15 <sup>[1]</sup>	<b>ADC1</b> — ADC input 1
				<b>GPIO15</b> — General Purpose digital Input/Output 15
				<b>SPI1_SCK</b> — Serial Peripheral Interface-bus 1, clock input/output
				<b>ANA_COMP_OUT</b> — Analog Comparator digital output
				<b>PWM3</b> — Pulse Width Modulator output 3
				<b>PDM1_DATA</b> — Pulse Density Modulation Data input from digital microphone (channel 1)
				<b>I2C0_SCL</b> — I2C-bus 0 master/slave SCL input/output (open drain)
				<b>RFRX</b> — Radio Receiver Control Output
FLASH_CSN	19		IO	<b>FLASH_CSN</b> — Chip select of internal serial flash, active low. Requires external pull-up (a 100 kΩ pull-up resistor is recommended).
V <sub>DDE</sub>	20	P		<b>V<sub>DDE</sub></b> — Supply voltage for IO
PIO17/ADC3	21	IO	GPIO17 <sup>[1]</sup>	<b>ADC3</b> — ADC input 3
				<b>GPIO17</b> — General Purpose digital Input/Output 17
				<b>SPI1_MOSI</b> — Serial Peripheral Interface-bus 1, master output slave input
				<b>SWO</b> — Serial Wire Output
				<b>PWM6</b> — Pulse Width Modulator output 6
				<b>SPIFI_IO3</b> — Quad-SPI Input/Output 3
				<b>ISO7816_CLK</b> — Clock output for ISO7816 interface
				<b>CLK_OUT</b> — Clock out
n.c.	22			not connected
n.c.	23			not connected
PIO20/ACP	24	IO	GPIO20 <sup>[1]</sup>	<b>ACP</b> — Analog Comparator Positive input
				<b>GPIO20</b> — General Purpose digital Input/Output 20
				<b>IR_BLAZER</b> — Infra-Red Modulator output
				<b>PWM8</b> — Pulse Width Modulator output 8
				<b>RFTX</b> — Radio Transmit Control Output
				<b>SPIFI_IO2</b> — Quad-SPI Input/Output 2
				<b>USART1_TXD</b> — Universal Synchronous/Asynchronous Receiver/Transmitter 1 - transmit data output

Table 4. Pin descriptions

Symbol	Pin	Type	Default at reset	Description
n.c.	25			not connected
TRST	26	G		<b>TRST</b> — must be connected to GND
RSTN	27	I		<b>RSTN</b> — Reset Not input
V <sub>BAT</sub>	28	P		<b>V<sub>BAT</sub></b> — Supply voltage DCDC input
LX	29			<b>LX</b> — DCDC filter
V <sub>SS(DCDC)</sub>	30	G		<b>V<sub>SS(DCDC)</sub></b> — ground for DCDC section
FB	31			<b>FB</b> — DCDC Feedback input
V <sub>DD(PMU)</sub>	32	P		<b>V<sub>DD(PMU)</sub></b> — supply voltage for PMU section
XTAL_32K_P	33			crystal oscillator 32.768 kHz
XTAL_32K_N	34			crystal oscillator 32.768 kHz
V <sub>DD(RADIO)</sub>	35	P		<b>V<sub>DD(RADIO)</sub></b> — supply voltage for radio section
V <sub>SS(RF)</sub>	36	G		<b>V<sub>SS(RF)</sub></b> — RF ground
RF_IO	37	IO		<b>RF_IO</b> — RF antenna, RF pin which can be considered as RF Input/output. The radio transceiver is connected here.
V <sub>SS(RF)</sub>	38	G		<b>V<sub>SS(RF)</sub></b> — RF ground
n.c.	39			not connected
FLASH_RSTN	40	IO		<b>FLASH_RSTN</b> — Reset signal for the internal flash device, active low. Requires external pull-up (a 100 kΩ pull-up resistor is recommended).
exposed die pad		G		must be connected to RF ground plane

- [1] I: input at reset.
- [2] For standard operation (normal boot or ISP programming mode), this pin should be high during the release of reset. If there is no external driver to this pin, then the internal pull-up will keep this pin high.
- [3] ISP programming mode: leave pin floating high during reset to avoid entering UART programming mode or hold it low to program.
- [4] In ISP mode, it is configured to USART0\_TXD.
- [5] In ISP mode, it is configured to USART0\_RXD.

### 7.3 Pin properties

Table 5. Pin properties

Pin No.	Pin Name	Default status after POR	Pullup/ Pulldown enable after POR	Pullup/ pulldown selection after POR	Slew rate after POR	Passive pin filter after POR	Open drain enable at reset	Open drain enable control	Pin interrupt	Fast capability
1	XTAL_P	—	—	—	—	—	—	—	—	—
2	XTAL_N	—	—	—	—	—	—	—	—	—
3	PIO0	H	Y	PU	SS	N	N	N	Y	N
4	PIO1	L	Y	PD	SS	N	N	N	Y	N
5	PIO2	L	Y	PD	SS	N	N	N	Y	N
6	PIO3	H	Y	PU	SS	N	N	N	Y	N
7	PIO4	H	Y	PU	SS	N	N	N	Y	N
8	PIO5/ISP_ENTRY	H	Y	PU	SS	N	N	N	Y	N
9	PIO6	L	Y	PD	SS	N	N	N	Y	N
10	PIO7	L	Y	PD	SS	N	N	N	Y	N
11	PIO8/TXD0	H	Y	PU	SS	N	N	N	Y	N
12	PIO9/RXD0	H	Y	PU	SS	N	N	N	Y	N
13	PIO10	Hi-Z	N <sup>[1]</sup>	EPU <sup>[1]</sup>	SS	N	N	Y	Y	N
14	PIO11	Hi-Z	N <sup>[1]</sup>	EPU <sup>[1]</sup>	SS	N	N	Y	Y	N
15	PIO12/SWCLK	H	Y	PU	SS	N	N	N	Y	N
16	PIO13/SWDIO	H	Y	PU	SS	N	N	N	Y	N
17	PIO14/ADC0	H	Y	PU	SS	N	N	N	Y	N
18	PIO15/ADC1	H	Y	PU	SS	N	N	N	Y	N
19	PIO16/ADC2 <sup>[2]</sup>	H	Y	PU	SS	N	N	N	Y	N
20	V <sub>DDE</sub>	—	—	—	—	—	—	—	—	—
21	PIO17/ADC3	L	Y	PD	SS	N	N	N	Y	Y
22	PIO18/ADC4 <sup>[4]</sup>	L	Y	PD	SS	N	N	N	Y	Y
23	PIO19/ADC5 <sup>[4]</sup>	L	Y	PD	SS	N	N	N	Y	Y
24	PIO20/ACP	L	Y	PD	SS	N	N	N	Y	Y
25	PIO21/ACM <sup>[4]</sup>	H	Y	PU	SS	N	N	N	Y	Y
26	TRST <sup>[3]</sup>	Hi-Z	N	—	—	—	—	—	N	—
27	RSTN	H	Y	PU	—	—	—	—	N	—
28	V <sub>BAT</sub>	—	—	—	—	—	—	—	—	—
29	LX	—	—	—	—	—	—	—	—	—

Table 5. Pin properties

Pin No.	Pin Name	Default status after POR	Pullup/ Pulldown enable after POR	Pullup/ pulldown selection after POR	Slew rate after POR	Passive pin filter after POR	Open drain enable at reset	Open drain enable control	Pin interrupt	Fast capability
30	V <sub>SS(DCDC)</sub>	—	—	—	—	—	—	—	—	—
31	FB	—	—	—	—	—	—	—	—	—
32	V <sub>DD(PMU)</sub>	—	—	—	—	—	—	—	—	—
33	XTAL_32K_P	—	—	—	—	—	—	—	—	—
34	XTAL_32K_N	—	—	—	—	—	—	—	—	—
35	V <sub>DD(RADIO)</sub>	—	—	—	—	—	—	—	—	—
36	V <sub>SS_RF</sub>	—	—	—	—	—	—	—	—	—
37	RFIN	—	—	—	—	—	—	—	—	—
38	V <sub>SS_RF</sub>	—	—	—	—	—	—	—	—	—
39	n.c.	—	—	—	—	—	—	—	—	—
40	FLASH_RSTN <sup>[5]</sup>	—	—	—	—	—	—	—	—	—

[1] External Pullup required

[2] On K32W041AM device, this requires external pull-up.

[3] Tie to ground for functional mode

[4] K32W041A device only. Otherwise n.c.

[5] K32W041AM device only. Otherwise n.c.

Table 6: Abbreviation used in the Table 6

Properties	Abbreviation	Descriptions
Default status after POR	Hi-Z	High impedance
	H	High level
	L	Low level
Pullup/ pulldown Enable after POR	Y	Enabled
	N	Disabled
Pullup/ pulldown selection after POR	PU	Pullup
	PD	Pulldown
Slew rate after POR	FS	Fast slew rate
	SS	Slow slew rate
Passive Pin Filter after POR	N	Disabled
	Y	Enabled

Table 6: Abbreviation used in the Table 6

Properties	Abbreviation	Descriptions
Open drain enable after reset	N	Disabled
	Y	Enabled
Open drain enable control	N	Disabled <sup>[1]</sup>
	Y	Enabled
Pin interrupt	N	Yes
	Y	No
Fast capability	N	Not support fast capability
	Y	Support fast capability

[1] All PIO except 10/11 can do pseudo-open drain

## 8. Functional description

### 8.1 Application CPU

The Arm Cortex-M4 includes three AHB-Lite buses, one system bus and the I-code and D-code buses. One bus is dedicated for instruction fetch (I-code), and one bus is dedicated for data access (D-code). The use of two core buses allows for simultaneous operations if concurrent operations target different devices.

A multi-layer AHB matrix connects the CPU buses and other bus masters to peripherals in a flexible manner that optimizes performance by allowing peripherals on different slave ports of the matrix to be accessed simultaneously by different bus masters. Note that while the AHB bus itself supports word, halfword, and byte accesses, not all AHB peripherals need or provide that support.

APB peripherals are connected to the AHB matrix via two APB buses using separate slave ports from the multilayer AHB matrix. This allows for better performance by reducing collisions between the CPU and the DMA controller, and also for peripherals on the asynchronous bridge to have a fixed clock that does not track the system clock. Note that APB, by definition, does not directly support byte or halfword accesses.

The CPU, AHB and DMA sub-systems are all synchronous and can operate at 48 MHz (FRO), 32 MHz (FRO), 32 MHz (XTAL), 24 MHz (FRO), 16 MHz (XTAL), 12 MHz (FRO).

#### 8.1.1 Arm Cortex-M4 processor

The Arm Cortex-M4 is a general purpose, 32-bit microprocessor, which offers high performance and very low-power consumption. The Arm Cortex-M4 offers many features, including a Thumb-2 instruction set, low interrupt latency, hardware divide, interruptible/continuable multiple load and store instructions, automatic state save and restore for interrupts, tightly integrated interrupt controller with wake-up interrupt controller, and multiple core buses capable of simultaneous accesses.

A 3-stage pipeline is employed so that all parts of the processing and memory systems can operate continuously. Typically, while one instruction is being executed, its successor is being decoded, and a third instruction is being fetched from memory.

### 8.1.2 Memory Protection Unit

The Cortex-M4 includes a Memory Protection Unit (MPU) which can be used to improve the reliability of an embedded system by protecting critical data within the user application.

The MPU allows separating processing tasks by disallowing access to each other's data. Access to memory regions can be disabled and also be defined as read-only. It detects unexpected memory accesses that could potentially break the system.

The MPU separates the memory into distinct regions and implements protection by preventing disallowed accesses. The MPU supports up to eight regions, each of which is divided into eight sub-regions. Accesses to memory locations that are not defined in the MPU regions, or not permitted by the region setting, will trigger memory management fault exception.

### 8.1.3 System Tick Timer (SysTick)

The Arm Cortex-M4 core includes a System Tick timer (SysTick) that generates a dedicated SYSTICK exception. The clock source for the SysTick can be the system clock, or a divided version of this.

### 8.1.4 Nested Vector Interrupt controller (NVIC)

The NVIC is an integral part of the Cortex-M4 that efficiently supports many interrupt sources with configurable priority levels.

#### 8.1.4.1 Features

- Nested Vectored Interrupt Controller that is an integral part of the CPU
- Tightly coupled interrupt controller provides low interrupt latency
- Controls system exceptions and peripheral interrupts
- 56 vectored interrupts
- 8 programmable interrupt priority levels with hardware priority level masking
- Relocatable vector table using Vector Table Offset Register VTOR
- Software interrupt generation
- Support for Non-Maskable Interrupt (NMI) from any interrupt

#### 8.1.4.2 General description

The tight coupling of the NVIC to the CPU allows for low interrupt latency and efficient processing of late arriving interrupts.

## 8.2 Memory

The K32W041A/K32W041AM incorporates several distinct memory regions.

The registers incorporated into the CPU, such as NVIC, SysTick, and sleep mode control, are located on the private peripheral bus.

The system memory map is shown in the following figure.

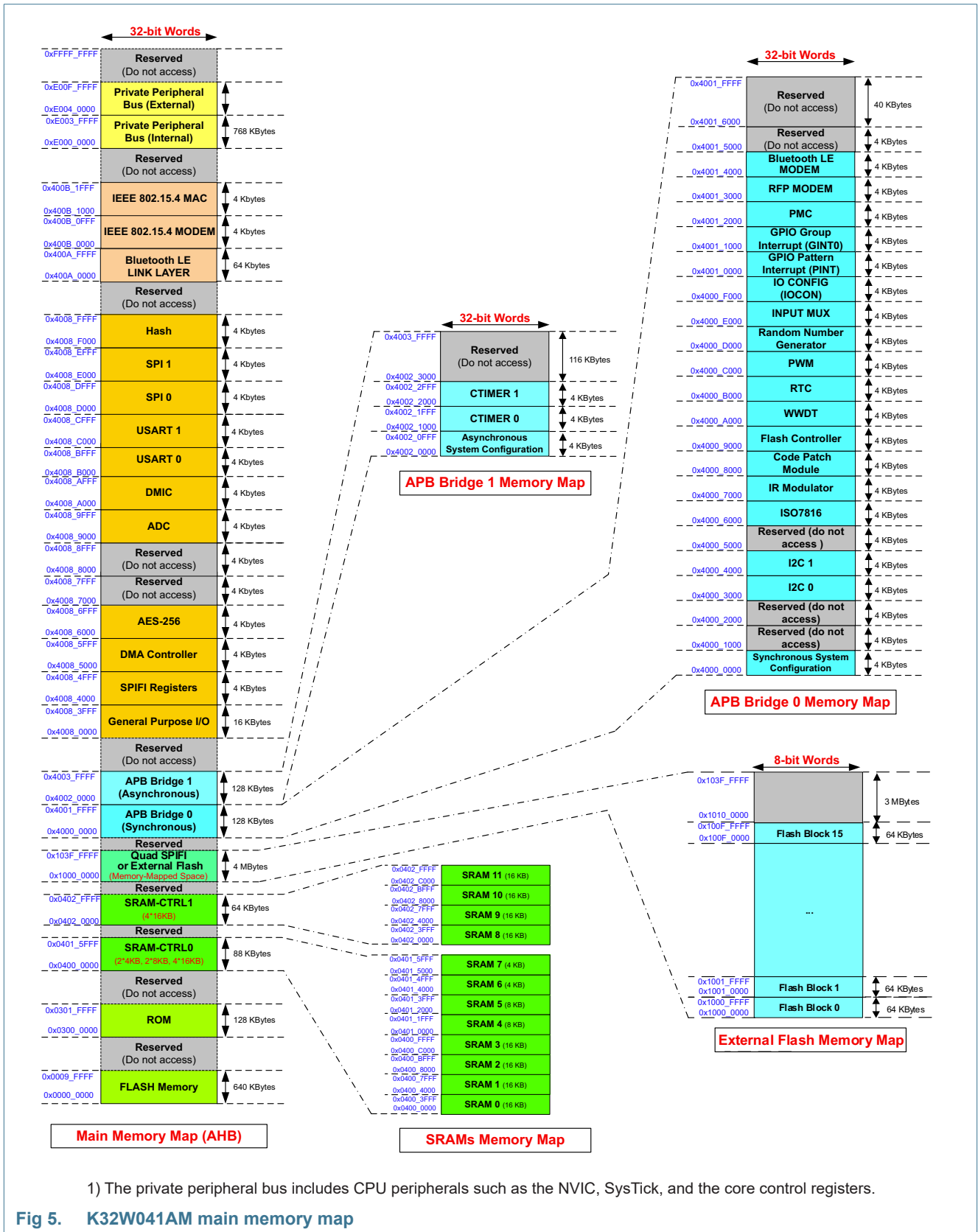

1) The private peripheral bus includes CPU peripherals such as the NVIC, SysTick, and the core control registers.

Fig 5. K32W041AM main memory map



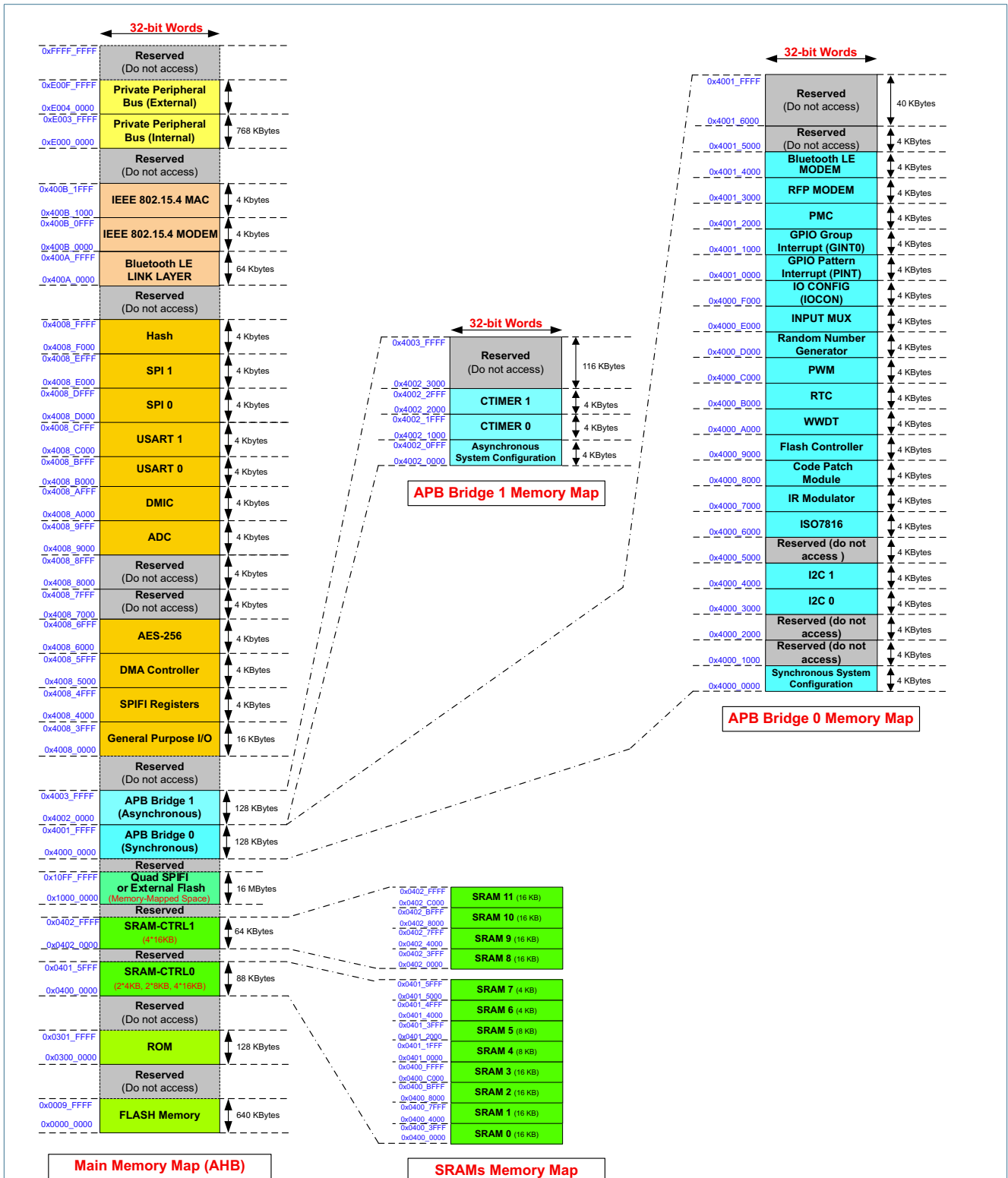

1) The private peripheral bus includes CPU peripherals such as the NVIC, SysTick, and the core control registers.

Fig 6. K32W041A main memory map

### 8.2.1 SRAM

The main SRAM is comprised of up to a total 152 KB on-chip static RAM memory. The main SRAM is implemented as several SRAM instances to allow for more control of power usage when less SRAM is required ( $2 \times 4$  KB instances,  $2 \times 8$  KB instances and  $8 \times 16$  KB instances). Each SRAM has a separate clock control and power switch.

See [Table 2](#) for SRAM size of each parts.

### 8.2.2 SRAM usage

Although always contiguous on all K32W041A/K32W041AM devices, the SRAM instances are divided between two AHB matrix ports. This allows user programs to potentially obtain better performance by dividing RAM usage among the ports. For example, simultaneous access to SRAM0 by the CPU and SRAM1 by the system DMA controller does not result in any bus stalls for either master.

Generally speaking, the CPU will read or write all peripheral data at some point, even when all such data is read from or sent to a peripheral by DMA. So, minimizing stalls is likely to involve putting data to/from different peripherals in RAM on each port.

Alternatively, sequences of data from the same peripheral could be alternated between RAM on each port. This could be helpful if DMA fills or empties a RAM buffer, then signals the CPU before proceeding on to a second buffer. The CPU would then tend to access the data while the DMA is using RAM on the other port.

### 8.2.3 FLASH

The K32W041A/K32W041AM embeds flash for code and data storage. It is accessed through a flash controller that simplifies the use of the flash.

- Embedded 640 KB of Flash, an additional 1 MB Data Flash is available on K32W041AM
- Flash sector is 512 bytes
- 100 kcycles page endurance guaranteed
- Software is provided to manage data storage in the flash and provides wear leveling features
- Data retention 10 years

### 8.2.4 AHB multilayer matrix

The K32W041A/K32W041AM uses a multi-layer AHB matrix to connect the CPU buses and other bus masters to peripherals in a flexible manner that optimizes performance by allowing peripherals that are on different slave ports of the matrix to be accessed simultaneously by different bus masters.

## 8.3 System clocks

The following system clocks are used to drive the on-chip subsystems:

- The low power wake timers are driven by a low frequency 32 kHz clock.
- The main digital systems are driven from a high frequency clock source.
- The system controller state machines are driven from a 1 MHz FRO.

These system clocks are used within the device for the digital functionality. Some functional blocks can also source a clock from the interface and this is explained in when the digital blocks are presented.

### 8.3.1 32 kHz clock

There are two possible sources for the 32 kHz clock.

There is an internal FRO that gives 32.768 kHz with accuracy of  $\pm 2\%$ ; this requires no external components.

A 32 kHz XTAL is also supported. The XTAL is connected to XTAL\_32K\_P and XTAL\_32K\_N pins. The cell has configurable internal capacitors and therefore, except for the XTAL itself, no other external components are typically required. Very accurate XTALs are available. This option is recommended for accurate timings.

### 8.3.2 High frequency system clock

There are two possible sources for the high-speed system clock.

There is an internal high speed FRO that supports clock frequencies of 48 MHz, 32 MHz, 24 MHz and 12 MHz. This does not require any external components and has an accuracy of  $\pm 2\%$ .

A 32 MHz XTAL is also supported. The cell has configurable internal capacitors and therefore, except for the XTAL itself, no other external components are typically required. An accurate XTAL must be used for the radio operation. The system clock can be chosen to be sourced from the FRO or XTAL and this choice is separate to the operation of the radio using the XTAL clock. When selecting the XTAL as the source for the high frequency system clock, it is possible to select 32 MHz or 16 MHz.

The high frequency system clock is used for the processor and the system buses.

### 8.3.3 1 MHz FRO

A 1 MHz FRO is used by the core system controller and the state machine involved in the device start-up and shut-down. High accuracy of this clock is not necessary and it has a tolerance of  $\pm 15\%$ .

## 8.4 Resets and brownout

A system reset initializes the device to a pre-defined state and forces the CPU to start program execution from the reset vector. The reset process that the K32W041A/K32W041AM goes through is as follows.

When power is first applied or when the external reset is released, the FRO1MHz is started, then the DCDC converter is started. After that, the system power domain is started. When these domains are stable, the flash and main core domain LDOs are enabled. When these are stable, the high speed FRO is enabled and the elements necessary for CPU operation are enabled. Configuration data is read from the flash and the boot process begins.

Depending on the configuration and flash contents then the application may be executed, or the device may enter In System Programming (ISP) mode.

The initial power-up sequence will not begin if the device power is too low; in this case the Power-on reset module will keep the device in a reset state until there is sufficient voltage. Additionally, the brown-out detect block will keep the device in reset until a safe operating voltage is reached.

Once the device is operating, the brownout module can be used to interrupt the processor in case operating voltage changes occur. This allows software to manage a clean response to the event. The brownout threshold is configurable to support a range of applications.

Several resets are supported that can affect all or most of the device. These are presented in the following sub-sections.

#### 8.4.1 External reset

An external reset is generated by a low level on the RSTN pin. Reset pulses longer than the minimum pulse width will generate a reset during active or power-down modes. Shorter pulses are not guaranteed to generate a reset. The K32W041A/K32W041AM is held in reset while the RSTN pin is low. When the applied signal reaches the reset threshold voltage on its positive edge, the internal reset process starts.

The K32W041A/K32W041AM has an internal pull-up resistor connect to the RSTN pin. This pin is the input for an external reset only.

#### 8.4.2 Software reset

A system reset can be triggered at any time through software control, causing a full chip reset and invalidating the RAM contents. For example, this can be executed within a user's application upon detection of a system failure.

#### 8.4.3 Watchdog timer

The watchdog timer can cause a full chip reset if it reaches its timeout point and it is configured to generate a reset, rather than an interrupt. In normal operation, the software will periodically service the watchdog to prevent this timeout occurring. Typically, a watchdog timeout indicates an unexpected lock-up within the system.

#### 8.4.4 Arm system reset

The CPU can cause a reset by requesting a System reset. This reset causes a reset of the CPU and the core digital functionality, digital peripherals and the 32 MHz XTAL. The power domains within the device, such as the DCDC converter and core LDO are unaffected so that the CPU will restart quicker than if a software reset is performed.

### 8.5 System configuration (SYSCON)

The device has many system level features which support the operation of the device, such as clock control. In addition there is functionality provided to allow the software to manage the system, such as controlling wake-up sources. These features include:

- System and bus configuration
- Clock select and control
- Reset control
- Wake-up control

- Brown-out (BOD) configuration
- High-accuracy frequency measurement function for on-chip and off-chip clocks, using a selection of on-chip clocks as reference clock
- Device ID register

## 8.6 Power management

This section provides an overview of power related information about K32W041A/K32W041AM devices.

These devices include a variety of adjustable regulators, power switches, and clock switches to allow fine tuning power usage to match requirements at different performance levels and reduced power modes. All devices include an on-chip API in the boot ROM to adjust power consumption in reduced power modes, and provide entry to those modes.

### 8.6.1 Power supply

The device is powered by VBAT, which requires a 10  $\mu$ F decoupling capacitor to ground.

To give efficient operation, the device has an on-chip DCDC buck converter; it is turned on when the device is in active and sleep modes and, using external connections, it provides the supply voltage to the PMU and Radio. The converter is powered from VBAT and the external output of the DCDC converter, FB, requires a 10  $\mu$ F decoupling capacitor to ground. For the DCDC converter to function correctly, a filtered version of FB must be input to LX. This is achieved with a 2.2  $\mu$ H inductor. The DCDC converter output, FB, must be routed to device pins VDD(radio) and VDD(pmu) so that the whole system is powered correctly.

The two VDD power inputs supply the power to most of the device, either directly or via on-chip regulators and power switches. These are used to manage power consumption based on the required mode of operation.

There is an always-on power domain which is powered by VBAT and includes the core functions to control device start-up and the functionality required in the very low power modes. This domain always has power as long as sufficient voltage is supplied to VBAT.

A further domain is important for supporting the power down mode. It includes the RTC, wake-up timer and some clock, reset and wakeup control. This domain is always has power as long as sufficient voltage is supplied to VDD and provided that the device is not in deep power-down mode.

See [Figure 10 “Application diagram – battery powered solution”](#) for the power connections.

### 8.6.2 Power modes

A variety of power modes are supported for the optimization of power consumption, including active, sleep, deep-sleep, power-down and deep power-down. Upon power-up or reset, the device enters active mode. After processing is complete, the software puts the chip into sleep mode or power-down mode, to save power consumption. The device is woken up either by a reset or an interrupt trigger like a GPIO interrupt, timer timeout, or other wake-up sources.

An API is provided so that software can easily use the power modes. The API performs all the configuration necessary for the different power modes, including setting power domains to the correct state and voltage, shutting down the flash controller safely, enabling the wake up mechanisms. The following sections introduces modes supported in order from highest to lowest power consumption.

#### 8.6.2.1 Active mode

The part is in active mode after a Power-On Reset (POR) and when it is fully powered and operational after booting.

#### 8.6.2.2 Sleep mode

Sleep mode saves a significant amount of power by stopping CPU execution without affecting peripherals or requiring significant wake-up time. The sleep mode affects the relevant CPU only. The clock to the core is shut off. Peripherals and memories are active and operational.

#### 8.6.2.3 Deep-sleep mode

Deep-sleep mode is highly configurable and can reduce power consumption, compared to Sleep mode by turning off more functions. Additionally, core voltages are reduced to save power. Wake-up times are longer than for Sleep mode due to the time needed to restart the functions. The clock to the CPU is shut down. The clock to the peripherals may also be disabled. The SRAM and registers maintain their internal states.

Entry to these modes can be accomplished by the CPU using the power profiles API, selected peripherals can be left running for safe operation of the part (e.g. RTC, WWDT and BOD, depending upon the mode). The flash is placed in standby mode and system clocks may be disabled.

#### 8.6.2.4 Power-down mode

In Power-down mode the core of the device and the flash is powered down, most clocks are stopped. Power consumption is very low with the cost of a longer wake-up time. The processor and most digital peripherals are powered off. USART0, SPI0 and I2C0 can operate with limited functionality in power down mode and have the ability to wake the device. Low power sleep timers can be enabled to generate a wake-up at a certain time in the future. Wakeup is also possible by GPIOs, analog comparator, RTC, and BOD VBAT. All, or part, of the SRAM can be optionally retained at the cost of extra current consumption.

#### 8.6.2.5 Deep power-down mode

Deep Power-down mode shuts down virtually all on-chip power consumption, but requires a significantly longer wake-up time. For maximal power savings, the entire system (CPU, memories and all peripherals) is shut down except for the PMU. Wake-up is possible from reset, and optionally GPIO. On wake-up, the part reboots.

#### 8.6.2.6 Wake-up sources

All interrupts to the CPU can be used as a wake-up from sleep.

The following table shows the possible wake-up sources from deep-sleep, power-down and deep power-down.

Table 7. Power mode wake-up sources

Wake-up source	Deep sleep	Power-down	Deep power-down
WWDT	Yes		
BOD	Yes	Yes	
GINT	Yes		
IR Modulator	Yes		
PINT [3:0]	Yes		
SPIFI	Yes		
TIMER [1:0]	Yes		
USART0	Yes	Yes	
USART1	Yes		
I <sup>2</sup> C0	Yes	Yes	
I <sup>2</sup> C1	Yes		
SPI0	Yes	Yes	
SPI1	Yes		
PWM[11:0]	Yes		
I <sup>2</sup> C2	Yes		
RTC	Yes	Yes	
ADC_SEQA	Yes		
ADC_THCMP_OVR	Yes		
DMIC	Yes		
HWVAD	Yes		
ISO7816	Yes		
ANA_COMP	Yes	Yes <sup>[1]</sup>	
WAKE_UP_TIMER[1:0]	Yes	Yes	
GPIO	Yes	Yes	Yes

[1] K32W041A device only.

## 8.7 Digital I/O

### 8.7.1 Features

- All 22 digital I/Os on K32W041A and 18 digital IOs on K32W041AM can be configured on GPIO ports
- GPIO pins can be configured as input or output by software
- All GPIO pins default to inputs with interrupt disabled at reset
- Pin registers allow pins to be sensed and set individually
- Group Interrupt to generate a single interrupt from AND or OR function of the digital IOs.
- Pin/ Pattern Interrupt allowing 4 IOs to be able to create an interrupt based on pin values or a combination of the values
- 2 IOs supporting true I<sup>2</sup>C mode or standard digital IO with configurable pull-up and drive strength

- 20 standard IO cells on K32W041A and 16 standard IO cells on K32W041AM are configurable for drive strength, pull-up resistor, pull-down resistor, pseudo open-drain

### 8.7.2 General description

The digital IOs have multiplexed functionality, supporting one or more digital peripherals and also a basic General Purpose IO function (GPIO). In GPIO mode it is possible to configure the IO as an input or as an output.

As an input it is possible to configure IO wake a device from powerdown and deep powerdown. The input value can also be read.

Using the Pin Interrupt/ Pattern Match function (PINT) it is possible to configure up to 4 digital IOs to be able to generate an interrupt based for active high or low functionality. Alternatively the 4 IOs can be combined in various ways to generate an interrupt. These interrupt are able to wake the CPU from sleep mode.

Additionally, a Group Interrupt function (GINT) allows any selection of up to all IOs to be combined into a AND or OR function in order to generate the group interrupt. The polarity of each IO used in the function can be configured.

Two of the digital IO cells support true I2C functionality and standard digital IO functionality, These support a pull-up resistor, drive strength control.

The other digital IOs cells are configurable to support drive strength options, pull-up or pull-down functions and the ability to operate in a pseudo open-drain mode.

The output value of each IO can be held during a power-down cycle if required.

Two DIO pins can optionally be used to provide control signals for RF circuitry (e.g. switches and PA) in high-power range extenders. PIO4\_8\_10\_14\_20/RFTX is asserted when the radio is in the transmit state and similarly, PIO5\_11\_15\_21/RFRX<sup>1</sup> is asserted when the radio is in the receiver state. From software and test perspective, it is recommended to PIO4 or PIO20 for RFTX and PIO5D or PIO21 for RFRX.

## 8.8 DMA controller

The DMA controller allows peripheral to memory, memory to peripheral, and memory single source and destination.

- 19 channels which are connected to peripheral DMA requests. These come from the USART, SPI-bus, I<sup>2</sup>C-bus, PDM and SPIFI interfaces. Any otherwise unused channels can also be used for functions such as memory-to-memory moves.
- DMA operations can be triggered by on-chip or off-chip events. Each DMA channel can select one trigger input from 18 sources. Trigger sources include ADC interrupts, timer interrupts, pin interrupts, and the SCT DMA request lines
- Priority is user selectable for each channel (up to eight priority levels)
- Continuous priority arbitration
- Address cache with four entries (each entry is a pair of addresses)
- Efficient use of data bus
- Supports single transfers up to 1,024 words

1. PIO21 is not available on K32W041AM.



- Address increment options allow packing and/or unpacking data

## 8.9 PWM

The PWM module supports the generation of up to 10 PWM waveforms on K32W041A and up to 9 waveforms on K32W041AM, each with its own prescaler, to support a range of applications.

- 1 PWM module with
  - 10 independent outputs on K32W041A
  - 9 independent outputs on K32W041AM
- Option for 1 channel to drive up to all (10 on K32W041A and 9 on K32W041AM) outputs simultaneously
- Programmable 10-bit prescaler for each channel
- 16-bit auto-reload down counter for each channel
- 16-bit compare register for each channel (toggling point in 1 full period)
- Predictable PWM initial output state for each channel (configurable initial waveform polarity – HIGH or LOW)
- Configurable level (HIGH or LOW) of PWM output when PWM is disabled
- Programmable overflow interrupt generation for each channel

## 8.10 Timers

Within the K32W041A/K32W041AM there are several different timer blocks available. These timers are used in different ways as outlined here.

- Counter/Timers: The two blocks are the main functional timers for the application, running off a high speed clock and able to create interrupts from match registers.
- Watchdog Timer: slow speed timer with the ability to interrupt the processor or cause device reset. Often used to identify when application software is locked up or taking too long.
- Real-time clock: this block has two timers real time clock and high-resolution/wake-up timer. The real time clock has a 1Hz clock is often run continually as a clock. The high-resolution/ wake up timer is a simple counter that can generate an input to wake the device from sleep, deep-sleep and power-down. Maximum timeout is 64 seconds.
- Low Power Wake-up Timers: this block has two timers running on a 32kHz clock. Predominantly used to wake the device from power-down, with a maximum time period in excess of one year.
- Tick Timer: within the processor this is often used for a regular heart beat to trigger software scheduling.

The device has different power modes and the following table shows when the timers can be used.

Table 8. Allowed timer usage in different power modes

Timer block	Active mode	Sleep mode	Deep-sleep mode	Power-down mode	Deep power-down mode
Counter/timer	X	X	X		
Watchdog timer	X	X	X		
Real-time clock	X	X	X	X	
Low Power wake-up timers	X	X	X	X	
Tick timer	X	X	X		

### 8.10.1 Counter/Timers

There are two Counter/Timer blocks that support a range of functions such as timers or counting events from an IO pin. The match registers allow for configurable interrupts when the counter reaches certain values. The match events can also be indicated on device pins.

#### 8.10.1.1 Features

- 2 counter/timer instances, CT32B0 and CT32B1
- Each is a 32-bit counter/timer with a programmable 32-bit prescaler. Both timers include external capture and match pin connections
- Counter or timer operation
- For each timer, up to 2 32-bit capture channels that can take a snapshot of the timer value when an input signal transitions. A capture event may also optionally generate an interrupt
- The timer and prescaler may be configured to be cleared on a designated capture event. This feature permits easy pulse-width measurement by clearing the timer on the leading edge of an input pulse and capturing the timer value on the trailing edge
- Four 32-bit match registers that allow:
  - Continuous operation with optional interrupt generation on match
  - Stop timer on match with optional interrupt generation
  - Reset timer on match with optional interrupt generation
- For each timer with pin connections, up to 2 external outputs corresponding to match registers with the following capabilities:
 

**Remark:** For the K32W041AM device, one timer has only one external match output and the other timer has two external match outputs. For K32W041A device, both timers have two external match outputs.

  - Set LOW on match
  - Set HIGH on match
  - Toggle on match
  - Do nothing on match
  - Two match registers can be used to trigger DMA transfers.

### 8.10.1.2 General description

Each counter/timer is designed to count cycles of the APB bus clock or an externally supplied clock and can optionally generate interrupts or perform other actions at specified timer values based on four match registers. Each counter/timer also includes one capture input to trap the timer value when an input signal transitions, optionally generating an interrupt.

**Capture inputs:** The capture signal can be configured to load the capture register with the value in the counter/timer and optionally generate an interrupt. The capture signal is generated by one of the pins with a capture function. Each capture signal is connected to one capture channel of the timer.

The counter/timer block can select a capture signal as a clock source instead of the APB bus clock.

**Match outputs:** When a match register equals the Timer Counter (TC), the corresponding match output can either toggle, go LOW, go HIGH, or do nothing.

#### Applications

- Interval timer for counting internal events
- Pulse Width Modulator via match outputs
- Pulse Width Demodulator via capture input
- Free running timer

### 8.10.2 Watchdog timer

The purpose of the Watchdog Timer is to reset or interrupt the microcontroller within a programmable time if it enters an erroneous state. When enabled, a watchdog reset is generated if the user program fails to feed (reload) the Watchdog within a predetermined amount of time.

When a watchdog window is programmed, an early watchdog feed is also treated as a watchdog event. This allows preventing situations where a system failure may still feed the watchdog. For example, application code could be stuck in an interrupt service that contains a watchdog feed. Setting the window such that this would result in an early feed will generate a watchdog event, allowing for system recovery.

- Internally resets chip if not reloaded during the programmable time-out period
- Optional windowed operation requires reload to occur between a minimum and maximum time-out period, both programmable
- Optional warning interrupt can be generated at a programmable time prior to watchdog time-out
- Clock fed to the watchdog function is selectable from 32 kHz clock, 32 MHz clock and FRO 1 MHz clock, This selected clock can be optionally pre-scaled before input to the block.
- Programmable 24-bit timer with internal fixed pre-scaler
- Selectable time period
- “Safe” watchdog operation. Once enabled, requires a hardware reset or a watchdog reset to be disabled

- Incorrect feed sequence causes immediate watchdog event if enabled
- The watchdog reload value can optionally be protected such that it can only be changed after the “warning interrupt” time is reached
- Flag to indicate watchdog reset
- The watchdog timer can be configured to run in Deep-sleep mode
- Debug mode

### 8.10.3 Real-Time Clock (RTC)

The Real-Time Clock provides two timers that are typically used as a Real-Time clock counter and a higher-resolution timer.

#### 8.10.3.1 Features

- The RTC has the following clock inputs generated from the 32 kHz FRO or 32 kHz XTAL:
  - 1 Hz clock for RTC timing
  - 1 kHz clock for high-resolution RTC timing
- 32-bit, 1 Hz RTC counter and associated match register for alarm generation
- Separate 16-bit high-resolution/wake-up timer clocked at 1 kHz for 1 ms resolution giving a maximum time-out period of over one minute.
- RTC alarm and high-resolution/wake-up timer time-out each generate independent interrupt requests. Either time-out can wake up the part from Low-power modes (Sleep mode, Deep-sleep mode or Power-down mode)

#### 8.10.3.2 General description

The RTC contains two timers:

- Real time clock

The real-time clock is a 32-bit up-counter which can be cleared or initialized by software. Once enabled, it counts continuously at a 1 Hz clock rate as long as the device is powered up and the RTC remains enabled.

The main purpose of the RTC is to count seconds and generate an alarm interrupt to the processor whenever the counter value equals the value programmed into the associated 32-bit match register.

If the part is in one of the reduced-power modes (Sleep, Deep-sleep, Power-down) an RTC alarm interrupt can also wake up the part to exit the Power mode and begin normal operation.
- High-resolution/wake-up timer

The time interval required for many applications, including waking the part up from a Low-power mode, will often demand a greater degree of resolution than the one-second minimum interval afforded by the main RTC counter. For these applications, a higher frequency secondary timer has been provided.

This secondary timer is an independent, stand-alone wake-up or general-purpose timer for timing intervals of up to 64 seconds with approximately one millisecond of resolution.

The high-resolution/wake-up timer is a 16-bit down counter which is clocked at a 1 kHz rate when it is enabled. Writing any non-zero value to this timer will automatically enable the counter and launch a countdown sequence. When the counter is being used as a wake-up timer, this write can occur just prior to entering a reduced power mode.

When a starting count value is loaded, the high-resolution/wake-up timer will turn on, count from the pre-loaded value down to zero, generate an interrupt and/or a wake-up command, and then turn itself off until re-launched by a subsequent software write.

#### 8.10.4 Low Power Wake-up Timers

Two low power wake-up timers are available on the K32W041A/K32W041AM, driven from the 32 kHz internal clock. They may run in power-down mode when the majority of the rest of the device is powered down, to time low-power periods or other long period timings that may be required by the application. The wake-up timers do not run during deep power-down and may optionally be disabled in power-down mode through software control. When a wake-up timer expires, it typically generates an interrupt; if the device is in deep sleep or power down mode then the interrupt may be used as an event to end the low power mode. Features include:

- 28-bit and 41-bit down counter
- Optionally runs during power-down periods
- Clocked by 32 kHz system clock; either 32 kHz RC oscillator or 32 kHz XTAL oscillator
- Time-out period in excess of 1 year is possible

A wake-up timer consists of a 28-bit or 41-bit down counter clocked from the selected 32 kHz clock. An interrupt or wake-up event can be generated when the counter reaches zero. On reaching zero, the counter will continue to count down until stopped, which allows the latency in responding to the interrupt to be measured. If an interrupt or wake-up event is required, the timer interrupt should be enabled before loading the count value for the period. Once the counter value has been loaded and the counter started, the count-down begins. The counter can be stopped at any time through software control - the counter will remain at the value that it contained when it was stopped and no interrupt will be generated. The status of the timers can be read to indicate if the timers are running and/or have expired; this is useful when the timer interrupts are masked.

#### 8.11 USART

There are 2 USART interfaces to provide Synchronous and Asynchronous serial communications with external devices. A range of features and flexible baud rate control supports a range of applications.

- 2 USART interfaces, 1 with flow control
- 7, 8 or 9 data bits and 1 or 2 stop bits
- Synchronous mode with master or slave operation. Includes data phase selection and continuous clock option
- Multiprocessor/multidrop (9-bit) mode with software address compare
- RS-485 transceiver output enable
- Parity generation and checking: odd, even, or none

- Software selectable oversampling from 5 to 16 clocks in asynchronous mode
- One transmit and one receive data buffer
- The USART function supports separate transmit and receive FIFO with 4 entries each
- RTS/CTS supported on one USART. This allows for hardware signaling for automatic flow control. Software flow control can be performed using delta CTS detect, transmit disable control, and any GPIO as an RTS output
- Break generation and detection
- Receive data is 2 of 3 sample "voting". status flag set when one sample differs
- Built-in baud rate generator with auto-baud function
- A fractional rate divider is shared among all USARTs
- Interrupts available for FIFO receive level reached, FIFO transmit level reached, receiver idle, change in receiver break detect, framing error, parity error, overrun, underrun, delta CTS detect, and receiver sample noise detected
- Loopback mode for testing of data and flow control
- USART transmit and receive functions can operate with the system DMA controller
- Special operating mode allows operation at up to 9600 baud using the 32 kHz RTC oscillator as the USART clock. This mode can be used, with USART0, while the device is in Power-down mode and can wake-up the device when a character is received

## 8.12 Serial Peripheral Interfaces-bus (SPI-bus)

The SPI-bus allows high-speed synchronous data transfer between the K32W041A/K32W041AM and peripheral devices. Two SPI-buses are supported which can independently operate as a master or slave to support a range of system configurations.

- 2 SPI-bus interfaces: SPI0 and SPI1 can be both configured as master or slave interfaces
- Data transmits of 1 to 16 bits supported directly. Larger frames supported by software
- The SPI-bus function supports separate transmit and receive FIFOs with 4 16-bit entries each
- Support DMA transfers: SPIn transmit and receive functions can operate with the system DMA controller
- Data can be transmitted to a slave without the need to read incoming data. This can be useful while setting up an SPI-bus memory
- Up to 3 slave select input/outputs with selectable polarity and flexible usage

**Remark:** Texas Instruments SSI and National Microwire modes are not supported.

## 8.13 I<sup>2</sup>C-bus interfaces

The K32W041A/K32W041AM supports the industry standard I<sup>2</sup>C-bus, a 2-wire synchronous serial interface that can operate as a master or slave, providing a simple and efficient method of data exchange between devices. The system uses serial data and clock to perform bidirectional data transfers.

- 2 I<sup>2</sup>C-bus interfaces, one with I<sup>2</sup>C compliant IO cells

- Independent master, slave and monitor functions
- Bus speeds supported:
  - Standard mode, up to 100 kbits/s
  - Fast-mode, up to 400 kbits/s
  - Fast-mode Plus, up to 1 Mbits/s (on specific I<sup>2</sup>C-bus pins)
  - High speed mode, 3.4 Mbits/s as a slave only (on specific I<sup>2</sup>C-bus pins)
- Supports both multi-master and multi-master with slave functions
- Multiple I<sup>2</sup>C-bus slave addresses supported in hardware
- One slave address can be selectively qualified with a bit mask or an address range in order to respond to multiple I<sup>2</sup>C-bus addresses
- 10-bit addressing supported with software assist
- Supports System Management Bus (SMBus)
- Separate DMA requests for master, slave, and monitor functions
- No chip clocks are required in order to receive and compare an address as a slave, so this event can wake up the device from Power-down mode with I<sup>2</sup>C0
- Automatic modes optionally allow less software overhead for some use cases

#### 8.14 DMIC interface

The DMIC subsystem supports mono or dual-channel digital PDM microphones. Additionally, hardware voice activity detector (HWVAD), is provided to support low power voice applications.

- DMIC (dual/stereo digital microphone interface)
  - PDM (Pulse-Density Modulation) data input for left and/or right channels on 1 or 2 buses.
  - Flexible decimation.
  - 16 entry FIFO for each channel.
  - DC blocking or unaltered DC bias can be selected.
  - Data can be transferred using DMA
- HWVAD (Hardware-based voice activity detector):
  - Optimized for PCM signals with 16 kHz sampling frequency.
  - Configurable detection levels.
  - Noise envelope estimator register output for further software analysis

#### 8.15 12-bit general purpose ADC

The K32W041A/K32W041AM has a 12-bit, multi-channel, general purpose ADC. Sampling is controlled by a configurable sequencer that can support a range of sampling options. With connections to the DMA sub-system complex applications using the ADC are possible.

- Conversion rate 190 ksamples/s (Max.) for 12-bit resolution
- Single-ended analog input mode

- 8 input channels on K32W041A, (6 external, 1 internal temperature sensor, 1 internal supply voltage monitoring); 5 input channels on K32W041AM, (3 external, 1 internal temperature sensor, 1 internal supply voltage monitoring)
- Selectable (max 32 clock-cycles) sampling time
- Power-down mode performing minimal power dissipation
- Peak to peak single-ended input range from 0 V to 3.6 V
- INL (Integral Non Linearity), full scale:  $\pm 1.1$  LSB typ.
- DNL (Differential Non Linearity):  $\pm 0.85$  LSB typ.
- ENOB (Effective Number Of Bit), 10% - 90% full scale,  $F_{in} = 25$  kHz: 10.5 typ.
- SNR (Signal to Noise Ratio),  $F_{in} = 25$  kHz: 65 dB typ.
- THD (Total Harmonic Distortion), 10% - 90% full scale,  $F_{in} = 25$  kHz:  $-70$  dB typ.
- SFDR (Spurious Free Dynamic Range), 10% - 90% full scale,  $F_{in} = 25$  kHz: 75 dB typ.
- A sequencer to control use of ADC
  - Sequencer triggered by software or PINT function, or PWM signal
  - Sample any combination of the ADC channels
  - Digital comparator function with two pairs of configurable low and high thresholds
  - Associate each ADC channel to one pair of low/high thresholds
  - Single step and bursts
  - Interrupts for data available, data overrun, threshold events

### 8.16 Temperature sensor

The K32W041A/K32W041AM provides a temperature sensor which is connected to one of the ADC channels. It provides an application with a temperature measurement.

- calibrated to give accurate measurement
- simple to use with software driver

### 8.17 Analog comparator

The K32W041A/K32W041AM provides an analog comparator that can compare two device pins or one pin against an internal reference.

- 1 analog comparator with 2 external inputs
- The negative source of the comparator can be set to an internal bandgap reference
- Can be enabled/disabled to save power
- Can be used to wake-up the device, from sleep, deep-sleep or power-down
- Rail to rail inputs
- The comparator provides 2 power modes to compromise between speed and power consumption
- The external pins can be routed to the + or – inputs of the comparator
- Hysteresis can be set to 0 mV or 40 mV
- The comparator output can be routed to an GPIO



On K32W041AM device, the comparator has only one external input which has to be routed to the positive input of the comparator. It can be compared to the internal bandgap reference. It is not possible to wake from power-down on this variant because the internal bandgap is not powered in the power-down state.

## 8.18 Infra-Red Modulator

The Infra-red modulator can generate patterns suitable to drive an infra-red source. The modulator is configurable to support several different IR protocols.

- 1 Infra-Red modulator instance
- Support Phillips RC5, RC6 & RCMM protocols
- Support SONY SIRC protocol
- Support 36 kHz sub-carrier frequency
- Support 40 kHz sub-carrier frequency

## 8.19 Serial Wire Debug (SWD)

Debug and trace functions are integrated into the Arm Cortex-M4. Serial wire debug and trace functions are supported. The Arm Cortex-M4 is configured to support up to 8 breakpoints and 4 watch points.

### 8.19.1 Features

- Supports Arm Serial Wire Debug mode for Cortex-M4
- Trace port provides Cortex-M4 CPU instruction trace capability. Output via a serial wire viewer
- Direct debug access to all memories, registers, and peripherals
- No target resources are required for the debugging session
- Breakpoints: the Cortex-M4 includes 8 instruction breakpoints that can also be used to remap instruction addresses for code patches. Two literal comparators that can also be used to remap addresses for patches to literal values.
- Watchpoints: the Cortex-M4 includes 4 data watchpoints that can also be used as triggers
- Instrumentation Trace Macrocell allows additional software controlled trace for the Cortex-M4

### 8.19.2 Basic configuration

The serial wire debug pins are enabled by default.

## 8.20 Wireless transceiver

The wireless transceiver comprises a 2.4 GHz radio that supports both the Bluetooth Low Energy and IEEE 802.15.4 radio standards. There is a IEEE802.15.4 compliant modem and baseband processor. There is also a Bluetooth Low Energy 5.0 compliant modem and link layer. These blocks, with IEEE 802.15.4 and Bluetooth Low Energy 5.0 protocol software provided as libraries, implement the standards-based wireless transceiver that transmits and receives data over the air in the unlicensed 2.4 GHz band. To support the IEEE 802.15.4 protocol an AES engine is also provided, in the K32W041A/K32W041AM,

to accelerate the required encryption features. The Bluetooth Low Energy Link layer block contains an internal AES engine to support the requirements of the encryption required for the Bluetooth Low Energy 5.0 standard.

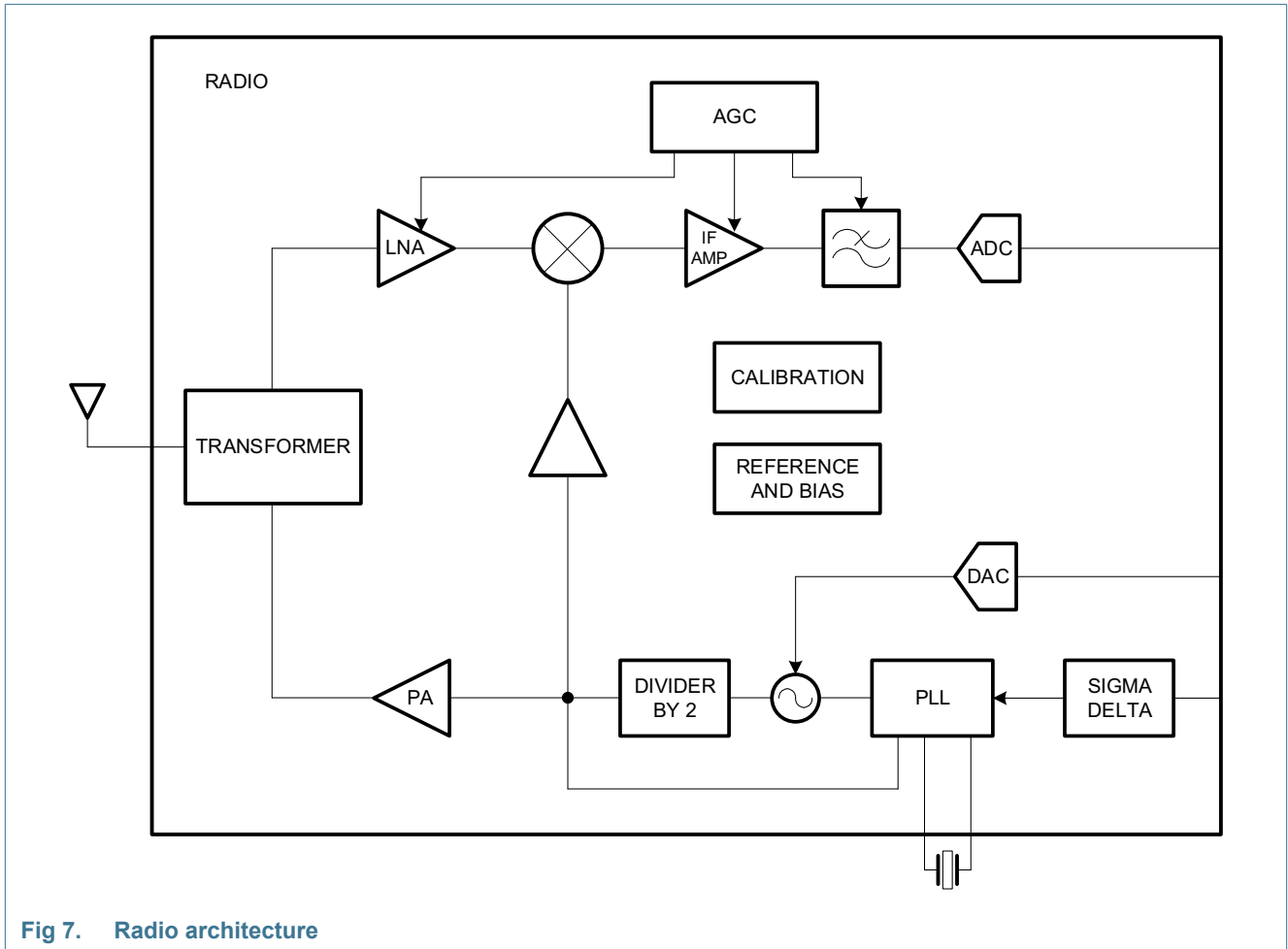

Fig 7. Radio architecture

The main features of the radio are:

- Single ended shared RF input for receive and transmit operations
- Each power domain has its own independent LDO
- A low noise PLL serving either the receiver or the transmitter. A 2-point modulation is used in TX

The single-ended antenna is connected to the integrated transformer. The integrated transformer has 2 outputs, one for the receive chain one for the TX chain.

The RX chain consists in an LNA, a mixer, an IF amplifier, an anti-aliasing filter and an ADC.

The LNA has some gain steps that are controlled by the AGC system.

The IF amplifier is the first gain stage after the mixer and provides some filtering. It has some gain steps that are controlled by the AGC system.

The anti-aliasing filter is the main channel filter. It also provides some gain steps that are controlled by the AGC system.

On the transmit side, the PA is built as 2 main blocks: one containing the RF pre-driver, one containing the power amplifier. The power amplifier has its own high power LDO.

The 32 MHz crystal oscillator provides the frequency synthesizer with a reference frequency. The synthesizer contains programmable feedback dividers, phase detector, charge pump and internal Voltage Controlled Oscillator (VCO). The VCO has no external components, and includes calibration circuitry to compensate for differences in internal component values due to process and temperature variations. The VCO is controlled by a Phase-Locked Loop (PLL) that has an internal loop filter. A programmable charge pump is also used to tune the loop characteristic.

The radio when enabled is automatically calibrated for optimum performance.

2 DIO pins can optionally be used to provide control signals for RF circuitry (e.g. switches and PA) in high-power range extenders. DIOx/RFTX is asserted when the radio is in the transmit state and similarly, DIOy/RFRX is asserted when the radio is in the receiver state.

### 8.20.1 Radio features

- 50  $\Omega$  single ended input (no external balun required)
- Flexible output power up to +15 dBm, programmable with 46 dB range
- Bluetooth Low Energy Sensitivity level -97 dBm
- IEEE 802.15.4 Sensitivity level -100 dBm
- Excellent linearity and phase noise to improve co-existence with WiFi interferences
- Ultra-fast AGC strategy
- Radio consumption in RX mode: 7.0 mA
- Radio consumption in TX mode at 0 dBm: 10.2 mA
- Radio consumption in TX mode at +3 dBm: 13 mA
- Radio consumption in TX mode at +10 dBm: 26 mA
- Radio consumption in TX mode at +15 dBm: 51 mA
- Antenna diversity control; in BLE mode, this is controlled by software.
- Option to use one or two GPIOs to control external LNA / PA devices
- Radio PHY ready for 2 Mbps bandwidth (Bluetooth Low Energy)

### 8.20.2 Modem

#### Bluetooth Low Energy modem

The modem provides all the necessary demodulation functions to receive Bluetooth Low Energy 5.0 data. This includes AGC operation in conjunction with radio features to be able to receive the wide range of signal powers.

Access Address detection is performed to identify and align to the start of a valid packet.

Frequency offset is determined and removed. Then data sampling is performed so that the packet data is presented to the link layer function.

IEEE 802.15.4 modem

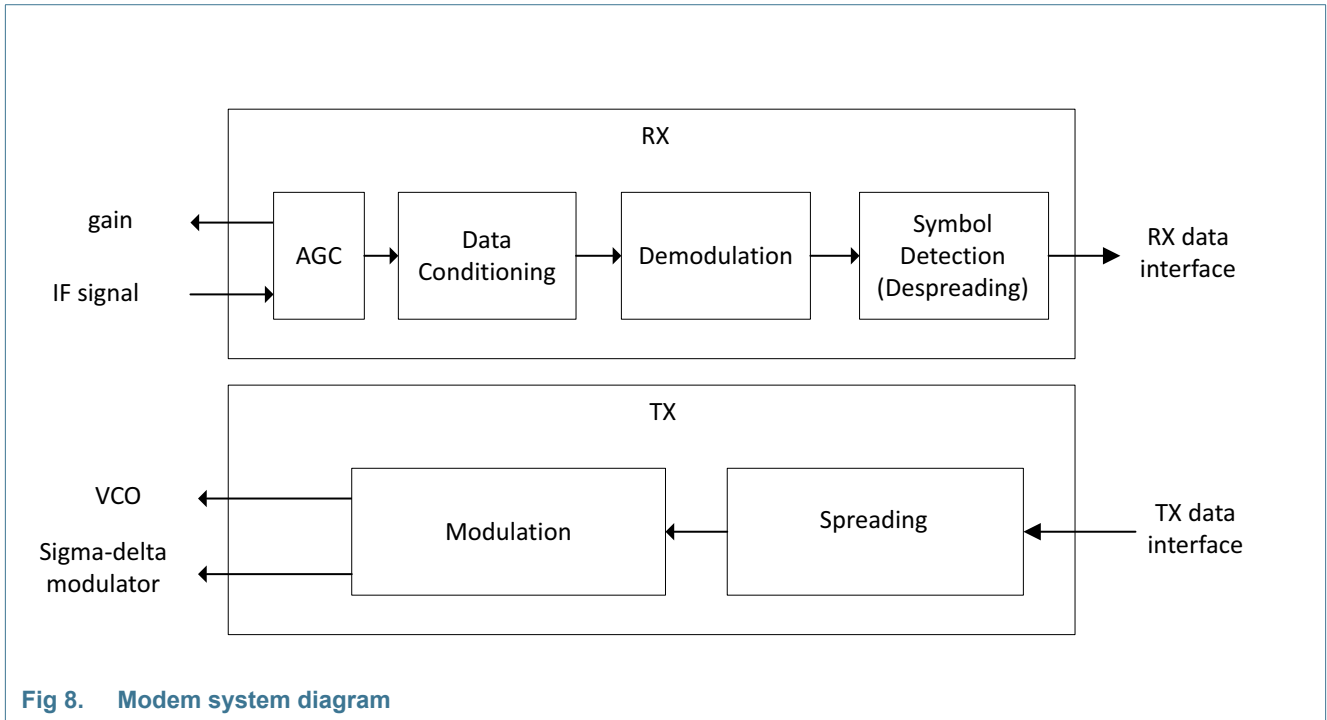

Fig 8. Modem system diagram

The modem performs all the necessary modulation and spreading functions required for digital transmission and reception of data at 250 kbits/s in the 2.4 GHz radio frequency band in compliance with the IEEE 802.15.4 standard.

Features provided to support network channel selection algorithms include Energy Detection (ED), Link Quality Indication (LQI) and fully programmable Clear Channel Assessment (CCA).

The modem provides a digital Receive Signal Strength Indication (RSSI) that facilitates the implementation of the IEEE802.15.4 ED function and LQI function. The ED and LQI are both related to receiver power. LQI is associated with a received packet, whereas ED is an indication of signal power-on air at a particular moment.

The CCA capability of the modem supports all modes of operation defined in the IEEE802.15.4 standard, namely Energy above ED threshold, Carrier Sense and Carrier Sense and/or energy above ED threshold.

8.20.3 IEEE 802.15.4 baseband processor

The baseband processor provides all time-critical functions of the IEEE802.15.4 MAC layer. Dedicated hardware guarantees air interface timing is precise. The MAC layer hardware/software partitioning enables software to implement the sequencing of events required by the protocol and to schedule timed events with millisecond resolution, and the hardware to implement specific events with microsecond timing resolution. The protocol software layer performs the higher-layer aspects of the protocol, sending management and data messages between End Device and Co-ordinator nodes, using the services provided by the baseband processor.

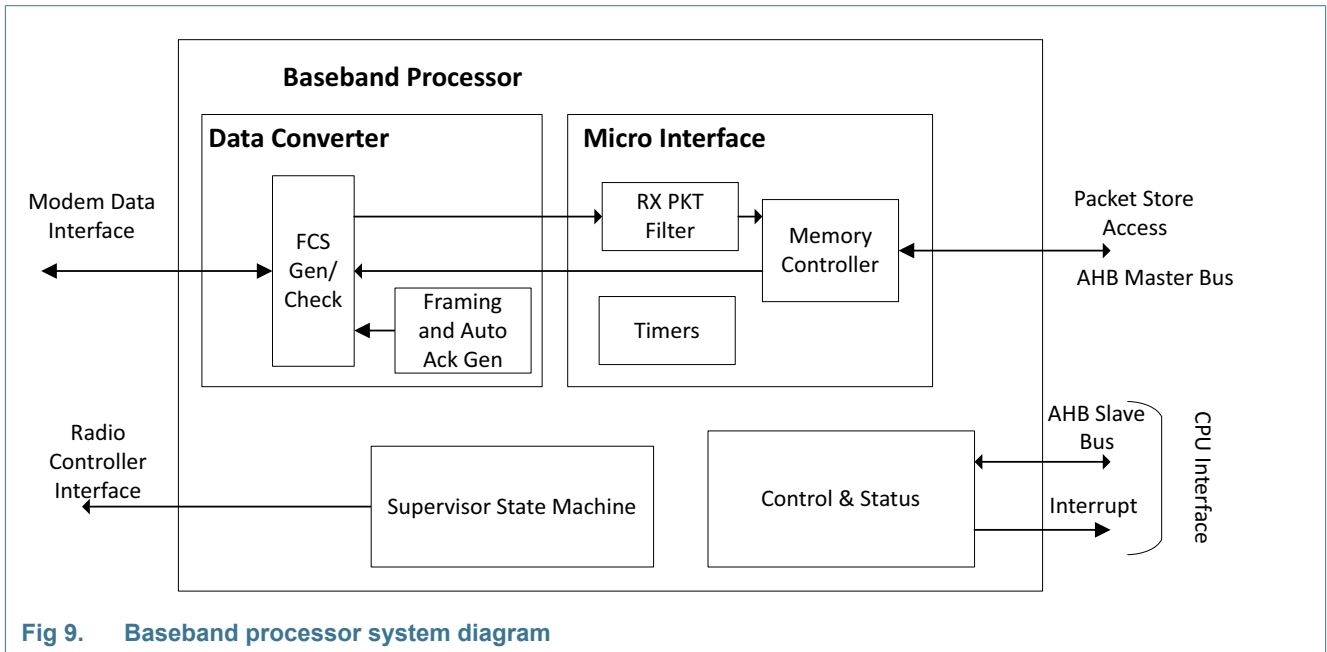

Fig 9. Baseband processor system diagram

8.20.3.1 Transmit

A transmission is performed by software writing the data to be transferred into the TX frame buffer in RAM, together with parameters such as the destination address and the number of retries allowed, as well as programming one of the protocol timers to indicate the time at which the frame is to be sent. This time will be determined by the software tracking the higher-layer aspects of the protocol such as superframe timing and slot boundaries. Once the packet is prepared and protocol timer set, the supervisor block controls the transmission. When the scheduled time arrives, the supervisor controls the sequencing of the radio and modem to perform the type of transmission required, fetching the packet data directly from RAM. It can perform all the algorithms required by IEEE802.15.4 such as CSMA/CA without processor intervention including retries and random back-offs.

When the transmission begins, the header of the frame is constructed from the parameters programmed by the software and sent with the frame data through the serializer to the modem. At the same time, the radio is prepared for transmission. During the passage of the bit-stream to the modem, it passes through a CRC checksum generator that calculates the checksum on-the-fly, and appends it to the end of the frame.

8.20.3.2 Reception

During reception, the radio is set to receive on a particular channel. On receipt of data from the modem, the frame is directed into the RX frame buffer in RAM where both header and frame data can be read by the protocol software. An interrupt may be provided on receipt of the frame. An additional interrupt may be provided after the transmission of an acknowledgement frame in response to the received frame, if an acknowledgement frame has been requested and the auto acknowledge mechanism is enabled. As the frame data is being received from the modem, it is passed through a checksum generator; at the end of the reception the checksum result is compared with the checksum at the end of the

message to ensure that the data has been received correctly. During reception, the modem determines the Link Quality, which is made available at the end of the reception as part of the requirements of IEEE 802.15.4.

#### 8.20.3.3 Auto acknowledge

Part of the protocol allows for transmitted frames to be acknowledged by the destination sending an acknowledge packet within a very short window after the transmitted frame has been received. The baseband processor can automatically construct and send the acknowledgment packet without processor intervention and hence avoid the protocol software being involved in time-critical processing within the acknowledge sequence. The baseband processor can also request an acknowledge for packets being transmitted and handle the reception of acknowledged packets without processor intervention.

#### 8.20.3.4 Security

The transmission and reception of secured frames using the Advanced Encryption Standard (AES) algorithm is handled by the stack software. The baseband processor and modem does not perform any encryption or decryption. To transmit an encrypted packet, the data in the packet must be encrypted and written into the RAM and then the baseband processor can be directed to transmit the encrypted data. Similarly, in receive, the encrypted data is written into the RAM by the baseband processor. The stack software must then perform the decryption.

The AES engine provided on chip supports hardware accelerated AES operations and can be used by the stack software or the application.

### 8.20.4 Bluetooth Low Energy link layer

The Link Layer supports the time-critical packet functions of the Bluetooth Low Energy 5.0 protocol. Data processing includes whitening and CRC functions. Received packets can be checked against a whitelist. Packet transmission and reception can be scheduled in advance. Then hardware state machines manage enabling the radio at the correct time and interfacing to the system RAM to transfer packet data. Additionally, AES encryption and decryption supported within the link layer.

For low power operation, a timer is able to operate in power down mode. Then the device will wake-up at the required time to continue Bluetooth Low Energy activity.

#### 8.20.5 Antenna diversity

Support is provided for antenna diversity, which is a technique that maximizes the performance of an antenna system. It allows the radio signal to be switched between two antennas that have very low correlation between their received signals. Typically, this is achieved by spacing two antennae around 0.25 wavelengths apart or by using 2 orthogonal polarizations. It is controlled by software.

In IEEE802.15.4 / Zigbee / Thread operation, using transmit diversity mode, if a packet is transmitted and no acknowledgment is received, the radio system can switch to the other antenna for the retry. Alternatively, antenna diversity can be enabled so that antenna switching will occur in receive mode when waiting for a packet. Receive diversity operates a combined HW timer and SW power threshold mode. In general, the antenna is switched every 60 ms. However, if two preamble symbols are detected, then the antenna switching stops; the software will check whether the signal strength exceeds a threshold. If the signal is too weak, then the antenna selected is switched and the automatic switching will

restart. If the signal is strong, the packet reception will continue. The overall system performance depends upon various factors such as the attenuation / isolation between the two antennas, the RF characteristics of the signals received on each antenna.

When operating in Bluetooth Low Energy 5.0 mode, the Bluetooth Low Energy application software can select which antenna to use; the selection criteria could be based on RSSI or packet error rate and it is the responsibility of the application to implement the selection mechanism. The same ADO (SELA) and ADE (SELB) outputs are used as in the IEEE 802.15.4 case.

When operating in dual mode, it is also possible to configure the Bluetooth Low Energy operations to use the antenna selected by IEEE 802.15.4 hardware mechanism.

The K32W041A/K32W041AM provides an output (ADO) on one of PIO7, PIO9 or PIO19 and optionally its complement (ADE) on PIO6 that can be used to control an antenna switch; this enables antenna diversity to be implemented easily (see [Figure 9](#)).

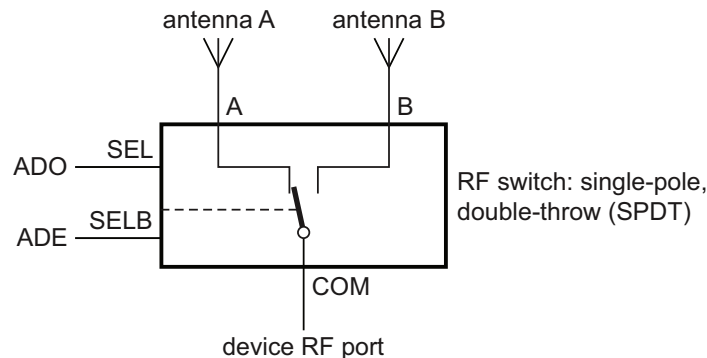

**Fig 10. Simple antenna diversity implementation using external RF switch**

If two PIO pins cannot be spared, one of the signals (ADE or ADO) from the K32W041A/K32W041AM can be used and its complement can be generated using an inverter on the PCB.

### 8.20.6 Radio usage

The Radio and antenna are shared between the Bluetooth Low Energy 5.0 and IEEE 802.15.4 specific hardware and the two protocol stacks. Software arbitration is required to ensure only one protocol attempts to use the radio at any point.

### 8.21 AES engine

The AES provides an on-chip hardware AES encryption and decryption engine to protect the image content and to accelerate processing for data encryption or decryption, data integrity, and proof of origin. Data can be encrypted or decrypted by the AES engine using the secret encrypted key in the OTP or a software supplied key

- 1 instance of Advanced Encryption Standard (AES)
- Support 128-bit keys for encryption and decryption
- Support 192-bit keys for encryption and decryption
- Support 256-bit keys for encryption and decryption

- Support for several protocols
  - ECB (Electronic Code Book)
  - CBC (Cipher Block Chaining)
  - CFB (Cipher Feedback)
  - OFB (Output Feedback)
  - CTR (Counter)
- DMA support with DMA triggers for input data and output data

## 8.22 SPI-bus Flash Interface (SPIFI)

For K32W041A device, the SPI-bus Flash Interface provides support for a master Quad SPI-bus capable of interfacing to a range of SPI devices for high throughput transfer of data between the K32W041A and an external device, such as a memory device. For the K32W041AM device, this interface is used to communicate to the flash memory device within the package.

- Supports 1-bit, 2-bit, and 4-bit bidirectional serial protocols, 4-bit mode only applicable to the K32W041A device.
- Half-duplex protocol compatible with various vendors and devices
- Operates at up to 32 MHz
- DMA support for transferring data to and from the SPIFI module

## 8.23 Hash module

The Hash function creates a fixed size signature from a block of data. It can be used as part of a scheme to check if data corruption has occurred.

- Support SHA-1
- Support SHA-256
- DMA support for efficient operation

## 8.24 ISO7816 smart card interface

The ISO smart card interface block, with suitable external analogue device, can support Smart Card reader applications.

- Compliant with ISO7816 standard
- Support of class A (5 V), Class B (3 V) and Class C (1.8 V) contact smart cards
- Support of ISO7816 UART interface
- Supports the asynchronous protocols (T=0 and T=1) in accordance with ISO7816
- Supports synchronous cards

## 8.25 Random number generator

The K32W041A/K32W041AM integrates a random number generator (RNG) for security purposes. The RNG generates, with suitable software, true non-deterministic random numbers for generating keys, initialization vectors and other random number requirements.



## 8.26 Data Flash

The K32W041AM devices include Data Flash. This is accessed via the SPIFI flash interface and can be used to store data such as software upgrades, received over the air, before they can be written to the internal flash memory or application data.

The features of the flash device are:

- Supports single (1-1-1) and dual output operation (1-1-2)
- 8 Mbit (1M x 8) flash memory
- 1 x 128-byte factory programmed unique identifier
- 3 x 128 byte one time programmable security registers
- Low power modes
- Operation at up to 33MHz
- Erase operations support a 4, 32 or 64-KB block erase or full chip erase
- Non-volatile status register configuration option

Connections to the flash device driven actively are QSPI\_CS (active low), QSPI\_CLK, QSPI\_IO0, QSPI\_IO1. Additionally, the active low reset signal of the flash is connected to FLASH\_RSTN device pin. The QSPI\_CSN and FLASH\_RSTN must each have a pull-up resistor to the device power supply, VDDE.

## 9. Application design-in information

### 9.1 K32W041A/K32W041AM module reference designs

For customers wishing to integrate the K32W041A/K32W041AM device directly into their system, NXP provides schematics and design files for the K32W0x Module Upgrade Boards.

To ensure the correct performance, it is strongly recommended that where possible the design details provided by the reference designs are used in their exact form for all end designs; this includes component values, pad dimensions, track layouts etc. In order to minimize all risks, it is recommended that the entire layout of the appropriate reference module, if possible, be replicated in the end design.

For full details, see web site or Contact technical support.

### 9.2 Schematic diagram

The PCB schematic and layout rules detailed in this data sheet must be followed. Failure to do so will likely result in the K32W041A/K32W041AM failing to meet the performance specification detailed in this data sheet and the worst case may result in the device not functioning in the end application.

A schematic diagram of the reference module is shown in [Figure 10](#). Details of component values and PCB layout constraints can be found in [Table 9](#).

The paddle should be connected directly to ground. Any pads that require connection to ground should do so by connecting directly to the paddle.

The

will enter UART programming mode if IN System Programming Entry (PIO5) pin 8 is low during RESET release.

The preferred communication interface is USART0 pins (PIO8/USART0\_TXD pin11 and PIO9/USART0\_RXD pin12).

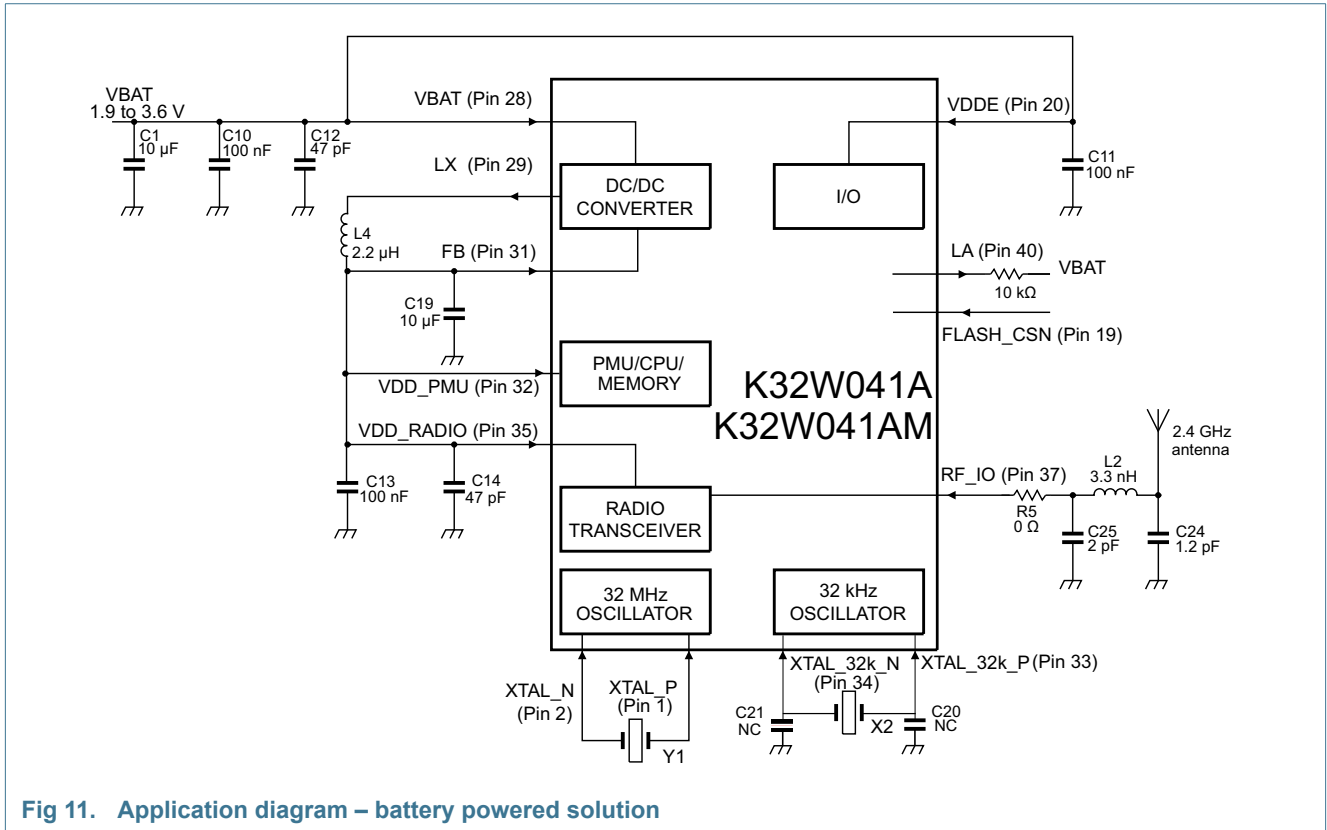

Fig 11. Application diagram – battery powered solution

For single-ended antennas or connectors, a balun is not required. However, an external filtering is needed. In receiver, the RFIO pin shows a 50 Ω impedance and external filtering (R5, C25, L2, C24) is needed in transmission to filter efficiently harmonics. These components are critical and must be placed close to the K32W041A/K32W041AM pins and analog ground.

The reference PCB is designed to present an accurate match to a 50 Ω resistive network as well as provide a DC path to the final output stage or antenna. Users wishing to match to other active devices such as amplifiers must design their networks to match to 50 Ω at the output of the K32W041A/K32W041AM.

The paddle must be connected directly to the ground. Any pads that require connection to the ground should do so by connecting directly to the paddle.

Table 9. Component descriptions about Figure 10

Component	Function	Value	Note
RF			
C24	RF filtering capacitor	1.2 pF	COG type
C25	RF filtering capacitor	2 pF	COG type
L2	RF filtering inductor	3.3 nH	MURATA (LQW15AN3N3B)

Table 9. Component descriptions about Figure 10

Component	Function	Value	Note
R5	Optional RF tuning area	0 $\Omega$	Not needed on ref design. Maybe needed to put an inductor for RF path tuning
Power			
C1	Power source decoupling	10 $\mu$ F	MURATA (GRM21BR71A106KA73L)
C10	Power source decoupling	100 nF	Locate less than 5mm from U1 pin 28
C12	Power source decoupling	47 pF	COG type
L4	DC-DC feedback filter inductor	2.2 $\mu$ H	TDK (MLZ2012M2R2HT000)
C19	DC-DC feedback filter capacitor	10 $\mu$ F	X7R MURATA (GRM21BR71A106KA73L)
C13	Radio and PMU decoupling	100 nF	Locate less than 5mm from U1 pins32/35
C14	Radio and PMU decoupling	47 pF	COG type
C11	DigitL4 and IO power decoupling	100 nF	Locate less than 5mm from U1 pin 20
Clock			
Y1	32 MHz crystal	32 MHz, 6 pF	NDK (NX2016SA 32 MHZ EXS00A-CS11213 6 pF)
X2	32.768 kHz crystal	32.768 kHz, 6 pF	NDK (NX2012SA 32.768 kHz EXS00A-MU01089 6pF)
C20-C21	optional 32.768 kHz crystal load capacitance	NC	

## 10. Limiting values

Table 10. Limiting values

In accordance with the Absolute Maximum Rating System (IEC 60134).

Symbol	Parameter	Conditions	Min	Max	Unit
V <sub>BAT</sub>	Supply voltage DCDC input		-0.3	3.96	V
V <sub>DDE</sub>	IO supply voltage		-0.3	3.96	V
V <sub>DD(Radio)</sub>	Radio supply voltage		-0.3	1.6	V
V <sub>DD(PMU)</sub>	PMU supply voltage		-0.3	1.6	V
V <sub>IO</sub>	IO pins voltage		-0.3	3.96	V
V <sub>RST</sub>	RSTN voltage		-0.3	3.96	V
V <sub>RFIO</sub>	Voltage on pin RFIO	[1]	-0.3	0	V <sub>DC</sub>
V <sub>ADC</sub>	ADC pins voltage		-0.3	3.96	V
V <sub>Lx</sub>	LA and LB pin voltage		-0.3	4.6	V <sub>peak</sub>
T <sub>stg</sub>	Storage temperature		-40	125	°C
V <sub>ESD</sub>	Electrostatic discharge voltage	HBM [2]	—	3000	V
		CDM [3]	—	500	V
t <sub>s</sub>	Max. V <sub>BAT</sub> slope	Ambient temperature: -40 °C V <sub>BAT</sub> from 0 V up to +3.6 V [4]	—	2	V/ms

[1] Primary input of RF transformer connected to the ground. No DC voltage.

[2] Testing for HBM discharge is performed as specified in JEDEC Standard JS-001.

[3] Testing for CDM discharge is performed as specified in JEDEC Standard JESD22-C101.

[4] Risk of physical damage if the V<sub>BAT</sub> slope is out of this specification

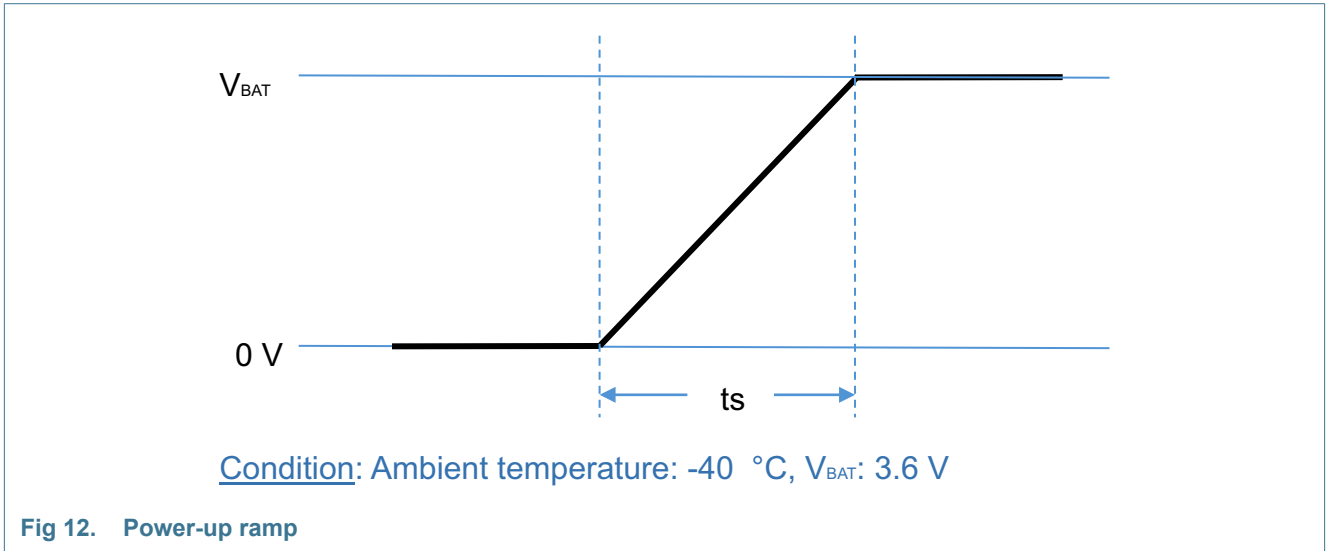

Fig 12. Power-up ramp

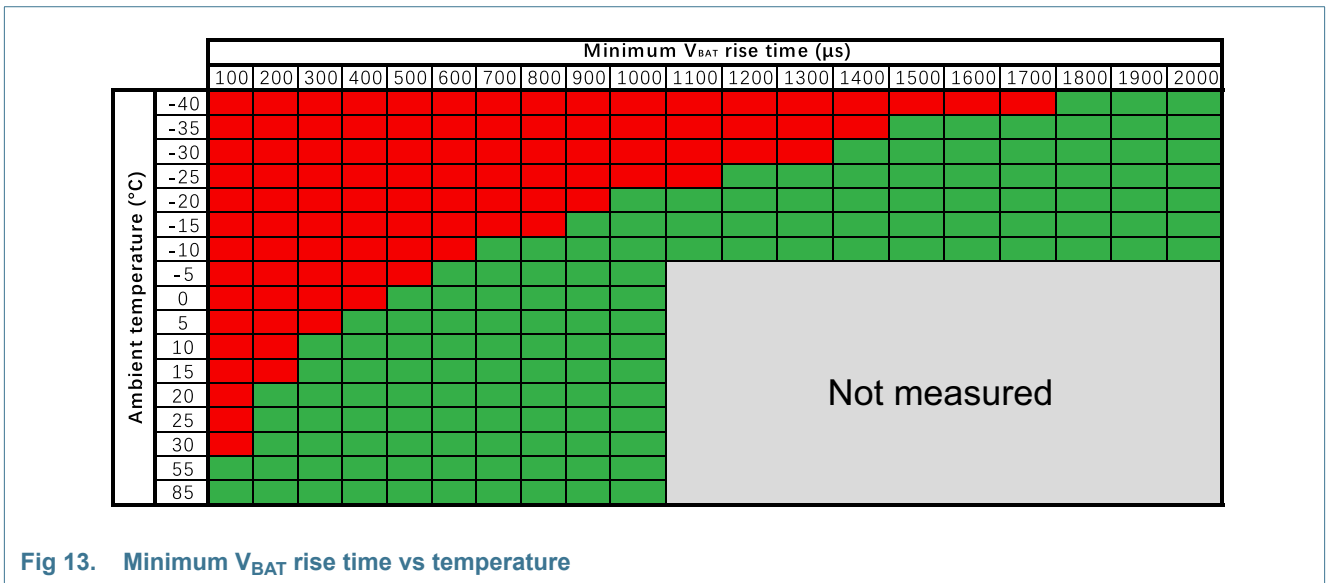

Fig 13. Minimum  $V_{BAT}$  rise time vs temperature

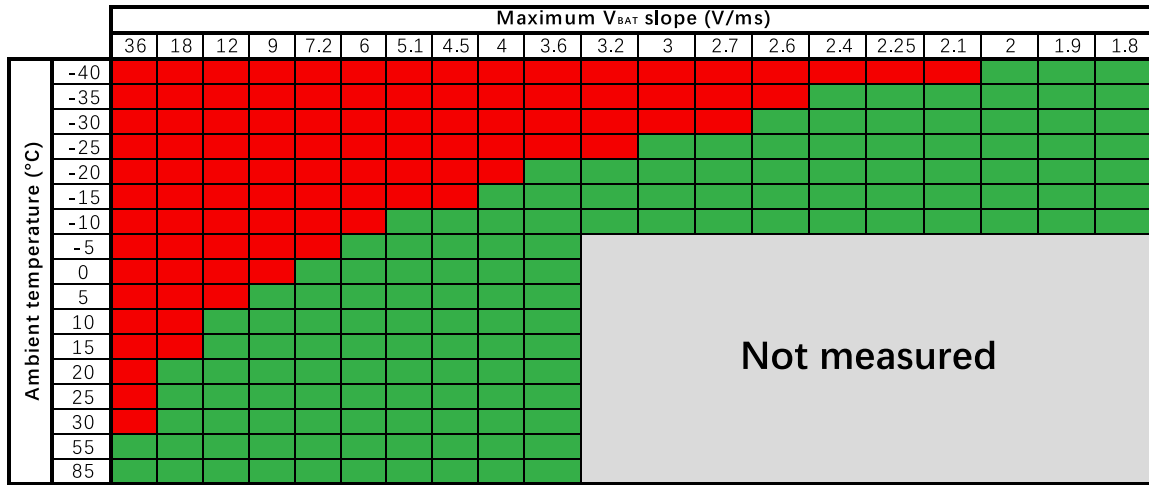

Fig 14. Maximum  $V_{BAT}$  slope vs temperature

## 11. Recommended operating conditions

Table 11. Operating conditions

Symbol	Parameter	Min	Max	Unit
$V_{BAT}$	DCDC supply voltage	2.4	3.6	V
$V_{DDE}$	IO supply voltage	2.4	3.6	V
$T_{amb}$	Ambient temperature	-40	85	°C

## 12. Thermal characteristics

Table 12. Thermal characteristics

Symbol	Parameter	Min	Typ	Max	Unit
$R_{th(j-a)}$	Thermal resistance from junction to ambient	—	28	—	K/W
$R_{th(j-c)}$	Thermal resistance from junction to case	—	4	—	K/W
$T_{j(max)}$	Maximum junction temperature	—	—	90	°C

### 13. Static characteristics

#### 13.1 Power consumption in Low-power mode

**Table 13. Typical current consumption in Low-power mode characteristics**

$V_{BAT} = 2.4\text{ V to }3.6\text{ V}$ ,  $T_{amb} = 25\text{ }^\circ\text{C}$

Symbol	Parameter	Conditions	Min	Typ	Max	Unit		
I <sub>DD</sub>	supply current	Deep power-down (everything is powered off, wake-up on HW reset only)	—	260	—	nA		
		Deep power-down-IO (everything is powered off, wake-up on HW reset only or an event on any of the GPIOs)	K32W041A	—	350	—	nA	
			K32W041AM	—	360	—	nA	
		Power-down (wake-up on HW reset or an IO event, wake-up timer ON, 32 kHz FRO on, no SRAM retention)	K32W041A	—	800	—	nA	
			K32W041AM	—	810	—	nA	
		Power-down-4K (wake-up on HW reset or an IO event, wake-up timer on, 32 kHz FRO on, with 4 KB SRAM retention])	K32W041A	—	1025	—	nA	
			K32W041AM	—	1035	—	nA	
		Power-down-8K (wake-up on HW reset or an IO event, wake-up timer on, 32 kHz FRO on, with 8 KB SRAM retention)	K32W041A	[1]	—	1120	—	nA
			K32W041AM	[1]	—	1130	—	nA
		Power down - RTC 1 kHz	[2]	—	200	—	nA	
		Power down - RTC 1 Hz	[2]	—	200	—	nA	
		Power down - per wake-up timer0 or timer1 / 32 kHz FRO		—	200	—	nA	
Power down - per wake-up timer0 or timer1 / 32 kHz XTAL		—	200	—	nA			
Power down - BOD VBAT	[2]	—	300	—	nA			
Power down - wake up on COM interfaces	[2] [3]	—	440	—	nA			

[1] Values achieved when application uses the optimized voltage configuration for power down. Any additional 4 KB RAM increases leakage current in typical condition by 105 nA.

[2] Will be added to the power down current consumption if used.

[3] Need to have retention on RAMBank7 (4 KB).

#### 13.2 Power consumption in Active mode

**Table 14. Typical current consumption in Active mode characteristics**

$V_{BAT} = 2.4\text{ V to }3.6\text{ V}$ ,  $T_{amb} = 25\text{ }^\circ\text{C}$ .

Symbol	Parameter	Conditions	Min	Typ <sup>[1]</sup>	Max	Unit	
I <sub>DD</sub>	supply current	radio in RX mode (IEEE 802.15.4 and Bluetooth Low Energy)	—	5.6	—	mA	
		radio in TX mode (IEEE 802.15.4 and Bluetooth Low Energy) with the output power of:	0 dBm	—	10.2	—	mA
			+3 dBm	—	13	—	mA
			+10 dBm	—	26	—	mA
			+15 dBm	—	51	—	mA

[1] Typ values are measured in high power mode.

Note: Infrastructure and CPU current consumption have to be added to Radio supply current.

**Table 15. Typical CPU and peripherals current consumption characteristics**

$V_{BAT} = 2.4\text{ V to }3.6\text{ V}$ ,  $T_{amb} = 25\text{ }^{\circ}\text{C}$ .

Symbol	Parameter	Conditions	Min	Typ	Max	Unit
$I_{DD}$	supply current	Current consumption measured on $V_{BAT}$ ; CPU core running CoreMark from embedded Flash memory, system clock 12 MHz <a href="#">[1]</a>	—	3.1	—	mA
		Current consumption measured on $V_{BAT}$ ; CPU core running CoreMark from embedded Flash memory, system clock 32 MHz <a href="#">[1]</a>	—	4.1	—	mA
		Current consumption measured on $V_{BAT}$ ; CPU core running CoreMark from embedded Flash memory, system clock 48 MHz <a href="#">[1]</a>	—	4.7	—	mA
$I_{DD(ADC)}$	ADC supply current	Continuous single channel acquisition at 190 KSPs <a href="#">[1]</a>	—	245.0	—	$\mu\text{A}$
$I_{DD(sintf)}$	SPI supply current	SPI bus supply current; continuous transmit at 2 MHz SPI CLK <a href="#">[1]</a>	—	462.6	—	$\mu\text{A}$
$I_{DD(DMA)}$	DMA supply current	Continuous transfer memory to memory of buffer size 1024 bytes <a href="#">[1]</a>	—	602.0	—	$\mu\text{A}$

[1] Radio and Modem are powered off. FRO at 32 kHz, XO at 32 kHz and XO at 32 MHz are powered off. FRO48M, FRO32M and FRO12M are on. Current consumption including FRO at 1 MHz, FRO at 192 MHz and Flash read access. All unused peripheral clocks are disabled. All unused IOs are in input mode.

### 13.3 Power consumption in-package Flash memory

The following characteristics are only for K32W041AM

**Table 16. Power consumption characteristics in-package Flash memory**

$V_{BAT} = 2.4\text{ V to }3.6\text{ V}$ ,  $T_{amb} = 25\text{ }^{\circ}\text{C}$ , unless otherwise specified.

Symbol	Parameter	Conditions	Min	Typ <sup>[1]</sup>	Max	Unit
$I_{DD}$	supply current	Standby current	—	16.6	—	$\mu\text{A}$
		Ultra deep power down	—	10	—	nA
		Active read current (at 33 MHz)	—	2.7	—	mA
		Program current	—	4.1	—	mA
		Erase current	—	4	—	mA

[1] Typ values are related to data flash low-power mode.

### 13.4 IO characteristics

**Table 17. IO characteristics**

$V_{DDE} = 2.4\text{ V to }3.6\text{ V}$ ,  $T_{amb} = -40\text{ }^{\circ}\text{C to }+85\text{ }^{\circ}\text{C}$ , unless otherwise specified.

Symbol	Parameter	Min	Typ	Max	Unit
$R_{pu(int)}(\text{PIO})$	Internal pull-up resistance on pins PIOx <a href="#">[1]</a>	40	50	60	k $\Omega$
$R_{pu(int)}(\text{RSTN})$	Internal pull-up resistance on pin RSTN	40	50	60	k $\Omega$
$R_{pdn(int)}(\text{PIO})$	Internal pull-down resistance on pins PIOx <a href="#">[1]</a>	40	50	60	k $\Omega$
IO					
$V_{IH}$	High-level input voltage	0.7 * $V_{DDE}$	—	$V_{DDE}$	V

**Table 17. IO characteristics ...continued**

$V_{DDE} = 2.4\text{ V to }3.6\text{ V}$ ,  $T_{amb} = -40\text{ }^{\circ}\text{C to }+85\text{ }^{\circ}\text{C}$ , unless otherwise specified.

Symbol	Parameter	Min	Typ	Max	Unit	
$V_{IL}$	Low-level input voltage	0.3	—	0.27 * $V_{DDE}$	V	
Output on pins PIO LS, with 1 mA load[2][4]						
$V_{OH}$	High-level output voltage	$V_{DD} = 3.6\text{ V}$	3.4	—	$V_{DDE}$	V
		$V_{DD} = 3.0\text{ V}$	2.8	—	$V_{DDE}$	V
		$V_{DD} = 2.4\text{ V}$	2.2	—	$V_{DDE}$	V
$V_{OL}$	Low-level output voltage	0	—	0.4	V	
Output on pins PIO LS, with 2 mA load[2][4]						
$V_{OH}$	High-level output voltage	$V_{DD} = 3.6\text{ V}$	3.3	—	$V_{DDE}$	V
		$V_{DD} = 3.0\text{ V}$	2.65	—	$V_{DDE}$	V
		$V_{DD} = 2.4\text{ V}$	2	—	$V_{DDE}$	V
$V_{OL}$	Low-level output voltage	0	—	0.4	V	
Output on pins PIO HS, with 3 mA load[3][4]						
$V_{OH}$	High-level output voltage	$V_{DD} = 3.6\text{ V}$	3.35	—	$V_{DDE}$	V
		$V_{DD} = 3.0\text{ V}$	2.75	—	$V_{DDE}$	V
		$V_{DD} = 2.4\text{ V}$	2.1	—	$V_{DDE}$	V
$V_{OL}$	Low-level output voltage	0	—	0.4	V	
Output on pins PIO HS, with 5 mA load[3][4]						
$V_{OH}$	High-level output voltage	$V_{DD} = 3.6\text{ V}$	3.2	—	$V_{DDE}$	V
		$V_{DD} = 3.0\text{ V}$	2.6	—	$V_{DDE}$	V
		$V_{DD} = 2.4\text{ V}$	2.05	—	$V_{DDE}$	V
$V_{OL}$	Low-level output voltage	0	—	0.4	V	
Output on pins PIO I <sup>2</sup> C, with 1 mA load[4][5]						
$V_{OH}$	High-level output voltage	$V_{DD} = 3.6\text{ V}$	3.45	—	$V_{DDE}$	V
		$V_{DD} = 3.0\text{ V}$	2.82	—	$V_{DDE}$	V
		$V_{DD} = 2.4\text{ V}$	2.30	—	$V_{DDE}$	V
$V_{OL}$	Low-level output voltage	0	—	0.4	V	
Output on pins PIO I <sup>2</sup> C, with 2 mA load[4][5]						
$V_{OH}$	High-level output voltage	$V_{DD} = 3.6\text{ V}$	3.30	—	$V_{DDE}$	V
		$V_{DD} = 3.0\text{ V}$	2.66	—	$V_{DDE}$	V
		$V_{DD} = 2.4\text{ V}$	2.10	—	$V_{DDE}$	V
$V_{OL}$	Low-level output voltage	0	—	0.4	V	
Currents						
$I_{LIL}$	Low-level input leakage current	—	4.5	—	nA	
$I_{LIH}$	High-level input leakage current	—	4.5	—	nA	

[1] All PIO except RSTN (reset), PIO10 and PIO11 (I<sup>2</sup>C function).

[2] PIO 0 to 9 and 12 to 16.

[3] PIO 17 to 21.

[4] Values from simulation.

[5] PIO 10 and 11. IO cell in GPIO mode.



## 14. Dynamic characteristics

### 14.1 AC characteristics

#### 14.1.1 Reset and Supply Voltage Monitor

**Table 18. Externally applied reset**

$V_{DDE} = 2.4\text{ V to }3.6\text{ V}$ ,  $T_{amb} = -40\text{ °C to }+85\text{ °C}$ , unless otherwise specified.

Symbol	Parameter	Conditions	Min	Typ	Max	Unit
$t_{rst}$	Reset time	External reset pulse width to initiate reset sequence <a href="#">[1]</a>	—	500	—	ns
$V_{rh}$	Reset high voltage	External threshold voltage, for reset to be sampled high (inactive) <a href="#">[2]</a>	$0.7 \times V_{DDE}$	—	—	V
$V_{rl}$	Reset low voltage	External threshold voltage for reset to be low (active) <a href="#">[2]</a>	—	—	$0.7 \times V_{DDE}$	V
$V_{th(POR)}$	Power-on reset threshold voltage	Rise time > 10 ms				
		rising	—	1.85	—	V
		falling	—	1.75	—	V
$t_{STAB}$	Stabilisation time	Time after release of reset until application runs	—	—	1.9	ms
$I_{DD}$	Supply current	Chip current when held in reset, $V_{DDE} = 3\text{ V}$	—	132	—	$\mu\text{A}$
$I_{rst(bod\ vbat)}$	Brownout reset current	Chip current when held in reset when voltage is above power-on-reset threshold but below brownout threshold	—	46	—	$\mu\text{A}$
$V_{th}$	Threshold voltage	Supply (VBAT) threshold voltage monitor <a href="#">[3]</a>	1.69	1.75	1.81	V
			1.74	1.8	1.86	V
			1.84	1.9	1.96	V
			1.94	2	2.06	V
			2.03	2.1	2.17	V
			2.13	2.2	2.27	V
			2.23	2.3	2.37	V
			2.32	2.4	2.48	V
			2.42	2.5	2.58	V
			2.52	2.6	2.68	V
			2.61	2.7	2.79	V
			2.71	2.8	2.89	V
			2.81	2.9	2.99	V
			2.91	3	3.09	V
3.00	3.1	3.2	V			
3.10	3.2	3.3	V			
3.20	3.3	3.4	V			

**Table 18. Externally applied reset ...continued**

$V_{DDE} = 2.4\text{ V to }3.6\text{ V}$ ;  $T_{amb} = -40\text{ }^{\circ}\text{C to }+85\text{ }^{\circ}\text{C}$ , unless otherwise specified.

Symbol	Parameter	Conditions	Min	Typ	Max	Unit
$V_{hys}$	Hysteresis voltage	Supply voltage (VBAT) monitor; configurable in 4 levels  [3]	18.75	25	31.25	mV
			37.50	50	62.5	mV
			56.25	75	93.75	mV
			75.00	100	125	mV

[1] Assumes internal pull-up resistor value of 100 kΩ worst case and ≈5 pF external capacitance.

[2] Minimum voltage to avoid being reset.

[3] Device setting from reset

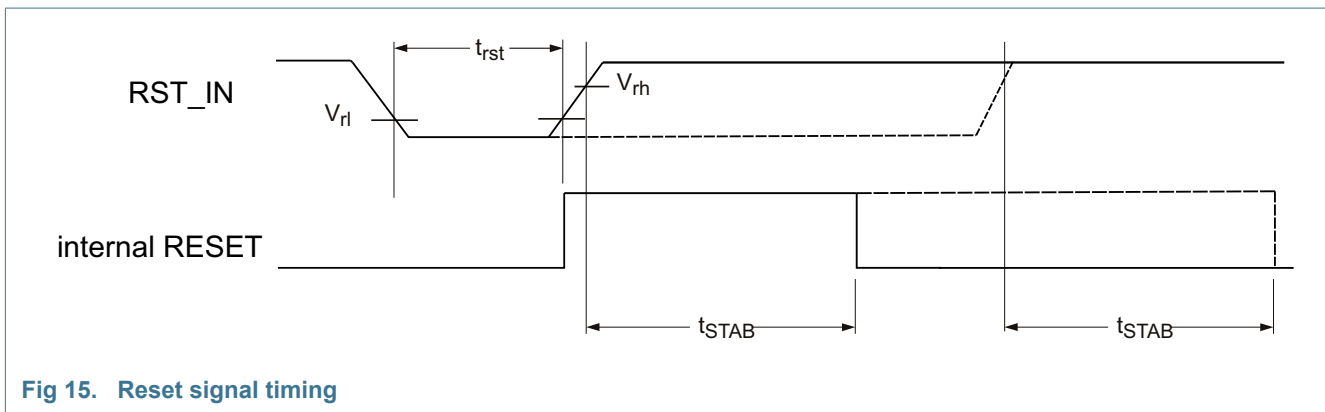

Fig 15. Reset signal timing

### 14.1.2 Analog to Digital Converters

**Table 19. Analog to Digital Converters**

$V_{DDE} = 2.4\text{ V to }3.6\text{ V}$ ;  $T_{amb} = -40\text{ }^{\circ}\text{C to }+85\text{ }^{\circ}\text{C}$ ; unless otherwise specified.

Symbol	Parameter	Conditions	Min	Typ	Max	Unit
$V_i$	Input voltage	switchable	0		$V_{BAT}$	V
FSR	Full scale range	After calibration	3.56	3.6	3.62	
$I_{ADCx}$	Current on pins ADCx[1]		—	100	—	μA
INL	Integral non-linearity		—	1.1	—	LSB
DNL	Differential non-linearity		—	0.85	—	LSB
$E_O$	Offset error	After calibration	-4.5	—	4.5	mV
$E_G$	Gain error	After calibration	-40	0	20	mV
$f_s$	Sampling frequency	Single channel	78.4	100	190	ksps
$t_{conv}$	Conversion time		—	10	—	μs
$C_{i(a)}$	Analog input capacitance		—	4	—	pF
SFDR	Spurious-free dynamic range	For $F_{in} = 25\text{ kHz}$	—	75	—	dBc

[1] With  $x = 0, 1, 2, 3, 4$ , or  $5$  for K32W041A;  $x = 0, 1$ , or  $3$  for K32W041AM.

### 14.1.3 Comparator

**Table 20. Comparator**

$V_{DDE} = 2.4\text{ V to }3.6\text{ V}$ ;  $T_{amb} = -40\text{ }^{\circ}\text{C to }+85\text{ }^{\circ}\text{C}$ ; unless otherwise specified.

Symbol	Parameter	Min	Typ	Max	Unit
$t_{resp}^{[1]}$	Response time -low power mode	—	2	—	$\mu\text{s}$
	Response time - standard mode	—	1.3	—	$\mu\text{s}$
$V_{hys}$	Hysteresis voltage	—	50	—	mV
$V_{ref\_ext}$	External reference voltage	0	—	$V_{DDE}$	V
$V_{ref\_int}$	Internal reference voltage	—	0.8	—	V
$V_{I(cm)}$	Common-mode input voltage	—	0.8	—	V

[1] Response time to trigger caused by square wave input.

### 14.1.4 32 kHz free running oscillator

**Table 21. 32 kHz free running oscillator**

$V_{DDE} = 2.4\text{ V to }3.6\text{ V}$ ;  $T_{amb} = -40\text{ }^{\circ}\text{C to }+85\text{ }^{\circ}\text{C}$ ; unless otherwise specified.

Symbol	Parameter	Min	Typ	Max	Unit
$f_{req}$	FRO center frequency	—	32.768	—	kHz
$\Delta f_{ffro}$	FRO accuracy	-2	—	2	%
$I_{DD}$	FRO current	—	200	—	nA

### 14.1.5 1 MHz free running oscillator

**Table 22. 1 MHz free running oscillator**

$V_{DDE} = 2.4\text{ V to }3.6\text{ V}$ ;  $T_{amb} = -40\text{ }^{\circ}\text{C to }+85\text{ }^{\circ}\text{C}$ ; unless otherwise specified.

Symbol	Parameter	Min	Typ	Max	Unit
$f_{req}$	FRO center frequency	—	1	—	MHz
$\Delta f_{ffro}$	FRO accuracy	-15	—	15	%
$I_{DD}$	FRO current	—	18	—	$\mu\text{A}$

### 14.1.6 32 kHz crystal oscillator

**Table 23. 32 kHz crystal oscillator**

$V_{DDE} = 2.4\text{ V to }3.6\text{ V}$ ;  $T_{amb} = -40\text{ }^{\circ}\text{C to }+85\text{ }^{\circ}\text{C}$ ; unless otherwise specified.

Symbol	Parameter	Min	Typ	Max	Unit
$f_{req}$	XTAL center frequency	—	32.768	—	kHz
$\Delta f_{ffro}$	XTAL accuracy	-500	—	500	ppm
$t_{startup}$	Start-up time	—	1	—	s
$I_{DD}$	XTAL current	—	200	—	nA

### 14.1.7 32 MHz crystal oscillator

**Table 24. 32 MHz crystal oscillator**

$V_{DDE} = 2.4\text{ V to }3.6\text{ V}$ ;  $T_{amb} = -40\text{ }^{\circ}\text{C to }+85\text{ }^{\circ}\text{C}$ ; unless otherwise specified.

Symbol	Parameter	Conditions	Min	Typ	Max	Unit
$f_{req}$	XTAL center frequency		—	32	—	MHz
$\Delta f_{ffro}$	XTAL accuracy		-40	—	40	ppm
$t_{startup}$	Start-up time	Time to reach 50 ppm accuracy	—	150	—	$\mu\text{s}$
$I_{DD}$	XTAL current		—	82	—	$\mu\text{A}$

### 14.1.8 High-speed free running oscillator

**Table 25. High-speed free running oscillator**

$V_{DDE} = 2.4\text{ V to }3.6\text{ V}$ ;  $T_{amb} = -40\text{ }^{\circ}\text{C to }+85\text{ }^{\circ}\text{C}$ ; unless otherwise specified.

Symbol	Parameter	Conditions	Min	Typ	Max	Unit
$f_{req}$	FRO center frequency	48 MHz clock output	—	48	—	MHz
		32 MHz clock output	—	32	—	MHz
		12 MHz clock output	—	12	—	MHz
$\Delta f_{ffro}$	FRO accuracy		-2	—	2	%

### 14.1.9 Temperature sensor

**Table 26. Temperature sensor**

$V_{DDE} = 2.4\text{ V to }3.6\text{ V}$ ;  $T_{amb} = -40\text{ °C to }+85\text{ °C}$ ; unless otherwise specified.

Symbol	Parameter	Conditions	Min	Typ	Max	Unit
$T_{sen}$	Sensor temperature range		-40	—	+90	°C
$G_{sen}$	Sensor gain	At ADC output after conversion	—	-10.12	—	LSB/°C
$\Delta T_{senSlope}$	Temperature sensor slope	After calibration at 25 °C	—	—	±2.5	%
$\Delta T_{sen25}$	Temperature accuracy at 25°C		—	±2	—	°C
$\Delta T_{sen}$	Sensor temperature accuracy	Full range -40 to +90 °C	-4.5	—	4.5	°C
$T_{TN}$	Temperature sensor thermal noise	After calibration at 25 °C	—	0.07	—	°C·RMS

### 14.2 Flash memory

**Table 27. Flash memory**

$V_{DDE} = 2.4\text{ V to }3.6\text{ V}$ ;  $T_{amb} = -40\text{ °C to }+85\text{ °C}$ ; unless otherwise specified.

Symbol	Parameter	Conditions	Min	Typ	Max	Unit
$N_{endu}$	Endurance	Page erase/program [1]	100000	—	—	cycles
		Mass erase/program [1]	100000	—	—	cycles
$t_{ret}$	Retention time	Powered	10	—	—	year
		Unpowered	10	—	—	year
$t_{erase}$	Erase time	1 Page (512 Bytes)	—	1.878	—	ms
$t_{blank}$	Blank status time	1 Page (512 Bytes)	—	21	—	µs
$t_{prog}$	Programming time	1 Page (512 Bytes)	—	1.09	—	ms

[1] Number of erase/program cycles, for Junction temperature range -40°C to 85°C

### 14.3 Internal Data Flash on K32W041AM

**Table 28. Internal serial flash memory**

$V_{DDE} = 2.4\text{ V to }3.6\text{ V}$ ;  $T_{amb} = -40\text{ °C to }+85\text{ °C}$ ; unless otherwise specified.

Symbol	Parameter	Conditions	Min	Typ	Max	Unit
$t_{chip\_erase}$	Chip erase time	1 Page (512 Bytes)	—	32	—	s
$t_{block\_erase}$	Block erase time	4 KB	—	66	—	ms
		32 KB	—	515	—	ms
		64 KB	—	800	—	ms
$t_{ret}$	Retention time	Powered	10	—	—	year
		Unpowered	10	—	—	year
$t_{prog}$	Page programming time	1 Page (256 Bytes)	—	1.5	—	ms
$t_{byte\_prog}$	Byte programming time		—	12	—	µs
$t_{otp\_prog}$	OTP security register programming time	≤10 K	—	5	—	ms
$t_{write\_prog}$	Write status register time		—	13	—	ms
$N_{endu}$	Endurance	Program/erase	—	100000	—	cycle
$t_{ret}$	Retention time		—	10	—	year

## 14.4 IO pins

**Table 29. Dynamic characteristic: I/O pins<sup>[1]</sup>**

$V_{DDE} = 2.4\text{ V to }3.6\text{ V}$ ;  $T_{amb} = -40\text{ °C to }+85\text{ °C}$ ; unless otherwise specified.

Symbol	Parameter	Conditions	Min	Typ	Max	Unit
PIO I <sup>2</sup> C <sup>[2][5]</sup>						
t <sub>R</sub>	Rise time	Slow speed, 3.3 V	12	—	22	ns
		Slow speed 1.9 V	14	—	28	ns
		Fast speed 3.3 V	1.7	—	5	ns
		Fast speed 1.9 V	3.2	—	7.5	ns
t <sub>F</sub>	Fall time	Slow speed, 3.3 V	14	—	29	ns
		Slow speed 1.9 V	18	—	34	ns
		Fast speed 3.3 V	1.1	—	2.6	ns
		Fast speed 1.9 V	2	—	4.7	ns
PIO HS <sup>[3][5]</sup>						
t <sub>R</sub>	Rise time	Slow speed, 3.3 V	1.6	—	4	ns
		Slow speed 1.9 V	2.4	—	6	ns
		Fast speed 3.3 V	0.8	—	3	ns
		Fast speed 1.9 V	1.2	—	4	ns
t <sub>F</sub>	Fall time	Slow speed, 3.3 V	1.1	—	3.3	ns
		Slow speed 1.9 V	1.6	—	5	ns
		Fast speed 3.3 V	0.6	—	3	ns
		Fast speed 1.9 V	0.9	—	3.5	ns
PIO LS <sup>[4][5]</sup>						
t <sub>R</sub>	Rise time	Slow speed, 3.3 V	2.2	—	5	ns
		Slow speed 1.9 V	3.3	—	7.5	ns
		Fast speed 3.3 V	1.6	—	4	ns
		Fast speed 1.9 V	2.5	—	6.5	ns
t <sub>F</sub>	Fall time	Slow speed, 3.3 V	1.2	—	3.5	ns
		Slow speed 1.9 V	1.9	—	5	ns
		Fast speed 3.3 V	0.7	—	3	ns
		Fast speed 1.9 V	1.1	—	3.5	ns

[1] Simulated data.

[2] PIO I<sup>2</sup>C values are for PIO10 and PIO11. IO cell in GPIO mode. Slow speed is EHS=0; Fast speed is EHS=1

[3] Values are for PIO17-21. Slow speed is SLEW(1:0) = 00b. Fast speed is SLEW(1:0) = 11b

[4] Values are for PIO0-9 and PIO12-16. Slow speed is SLEW(1:0) = 00b. Fast speed is SLEW(1:0) = 11b

[5] Pin capacitance load = 10 pF

[6] The slew rate is configured in the IOCON block. See K32W041A/K32W041AM User Manual.

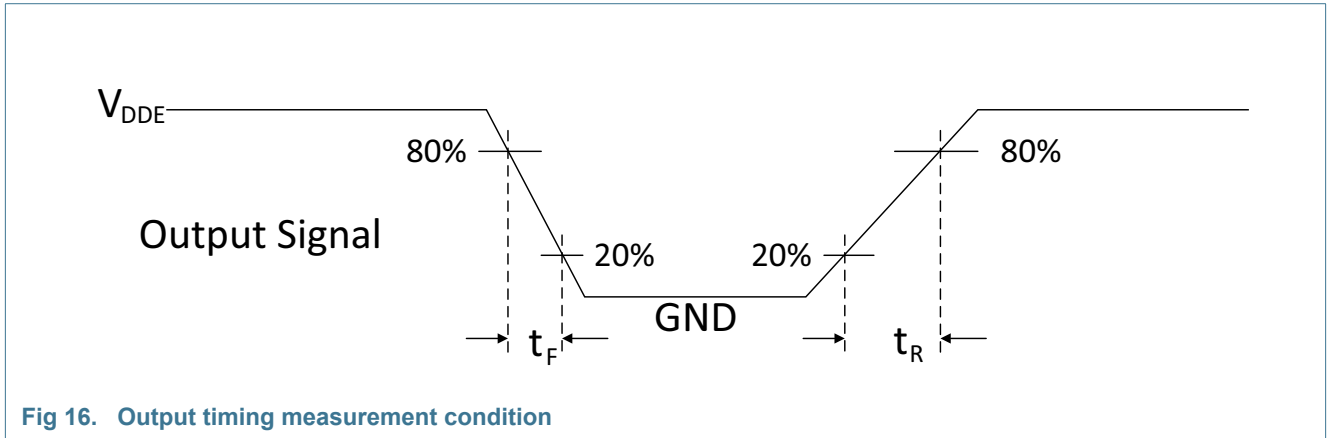

Fig 16. Output timing measurement condition

### 14.5 Wake-up timing

Table 30. Wake-up timing

$V_{DDE} = 2.4\text{ V to }3.6\text{ V}$ ;  $T_{amb} = -40\text{ }^\circ\text{C to }+85\text{ }^\circ\text{C}$ ; unless otherwise specified.

Symbol	Parameter	Conditions	Min	Typ	Max	Unit
$t_{startup}$	CPU startup time	Time for CPU to be running application code when VBAT > VBAT_BOD threshold <sup>[1]</sup>	—	1.9	—	ms
	XTAL startup time	Time to 32M XTAL ready for radio operation	—	350	—	$\mu\text{s}$
$t_{wake}$	Sleep wake-up time	Time to CPU to be running after wake-up trigger	—	0.2	—	$\mu\text{s}$
	power-down wake-up time	Time to CPU to be running after wake-up trigger with RAM held	—	392	—	$\mu\text{s}$
	power-down wake-up time	Time to CPU to be running after wake-up trigger without RAM held	—	836	—	$\mu\text{s}$
	deep power-down wake-up	Time to CPU to be running after wake-up trigger	—	936	—	$\mu\text{s}$

[1] Time to start of executing simple application.

### 14.6 SPI timing

Table 31. SPI master timing

$V_{DDE} = 2.4\text{ V to }3.6\text{ V}$ ;  $T_{amb} = -40\text{ }^\circ\text{C to }+85\text{ }^\circ\text{C}$ ; unless otherwise specified;  $CL = 10\text{ pF}$  balanced loading on all pins; Input slew = 1 ns; SLEW set to standard mode for all pins; Parameters samples at the 90% and 10% level of the rising or falling edge.

Symbol	Parameter	Min	Typ	Max	Unit
$t_{DS}$	Data set-up time	10	—	—	ns
$t_{DH}$	Data hold time	5	—	—	ns
$t_{V(Q)}$	Data output valid time	-2	—	15	ns
$t_{cy(SCK)}$	SCK frequency	0.01	—	8	MHz
	Duty cycle	45	50	55	%
$t_{SS}$	SSEL low before SCK edge <sup>[1]</sup>	1	—	—	SCK cycles
$t_{SH}$	SSEL low after last SCK edge <sup>[2]</sup>	0.5	—	—	SCK cycles

[1] Pre-delay can be configured to increase this time in steps of 1 SCK cycle

[2] Post-delay can be configured to increase this time in steps of 1 SCK cycle

**Table 32. SPI slave timing**

$V_{DDE} = 2.4\text{ V to }3.6\text{ V}$ ;  $T_{amb} = -40\text{ }^{\circ}\text{C to }+85\text{ }^{\circ}\text{C}$ ; unless otherwise specified;  $CL = 10\text{ pF}$  balanced loading on all pins; Input slew = 1 ns; SLEW set to standard mode for all pins; Parameters samples at the 90% and 10% level of the rising or falling edge.

Symbol	Parameter	Min	Typ	Max	Unit
$t_{DS}$	Data set-up time	12	—	—	ns
$t_{DH}$	Data hold time	5	—	—	ns
$t_{V(Q)}$	Data output valid time	0	—	35	ns
$t_{cy(SCK)}$	SCK frequency	—	—	8	MHz
$t_{SS}$	SSEL low before SCK edge	[1]	1	—	ns
$t_{SH}$	SSEL low after last SCK edge	[2]	0.5	—	ns

[1] Pre-delay can be configured to increase this time in steps of 1 SCK cycle

[2] Post-delay can be configured to increase this time in steps of 1 SCK cycle

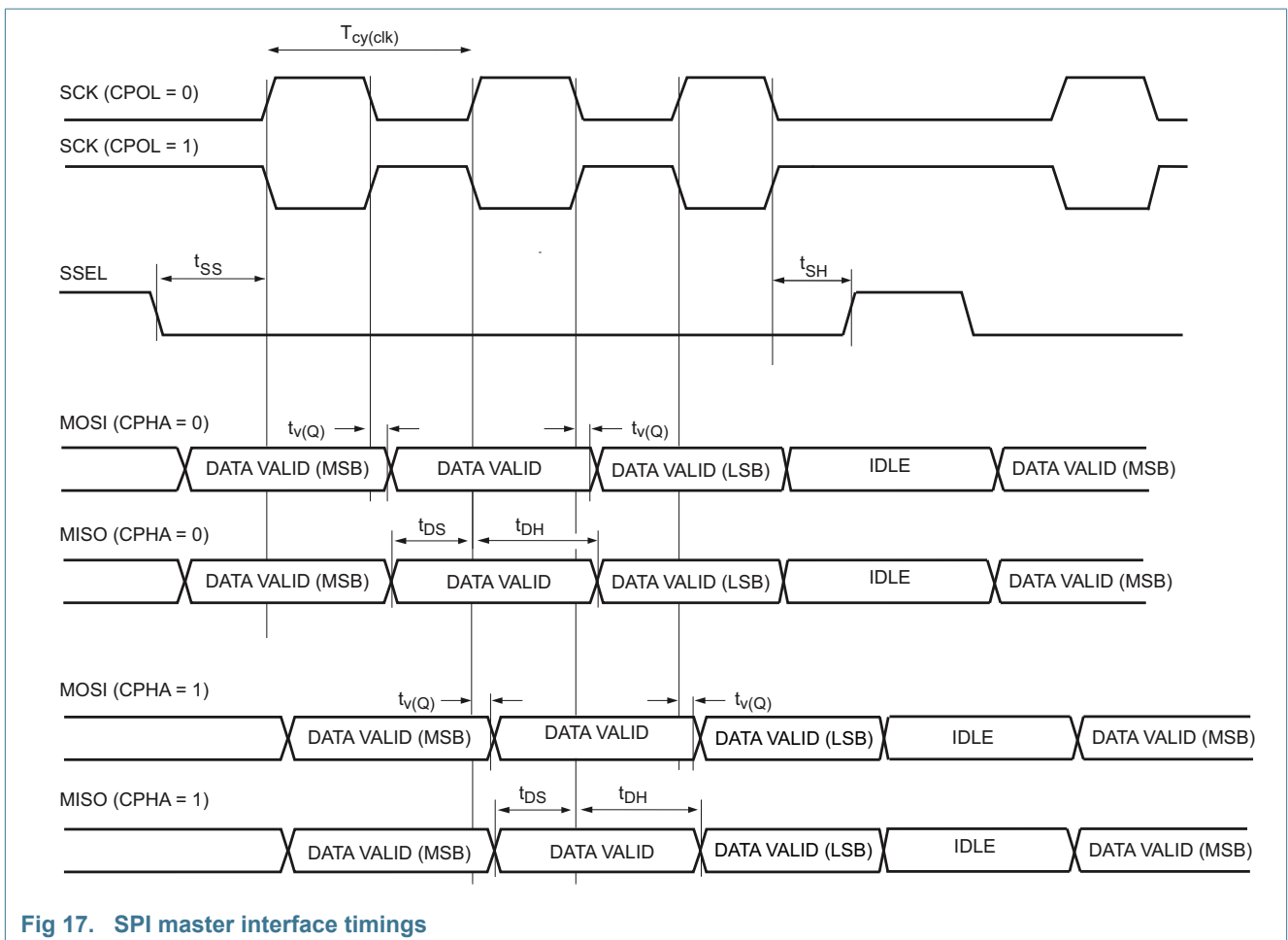

**Fig 17. SPI master interface timings**



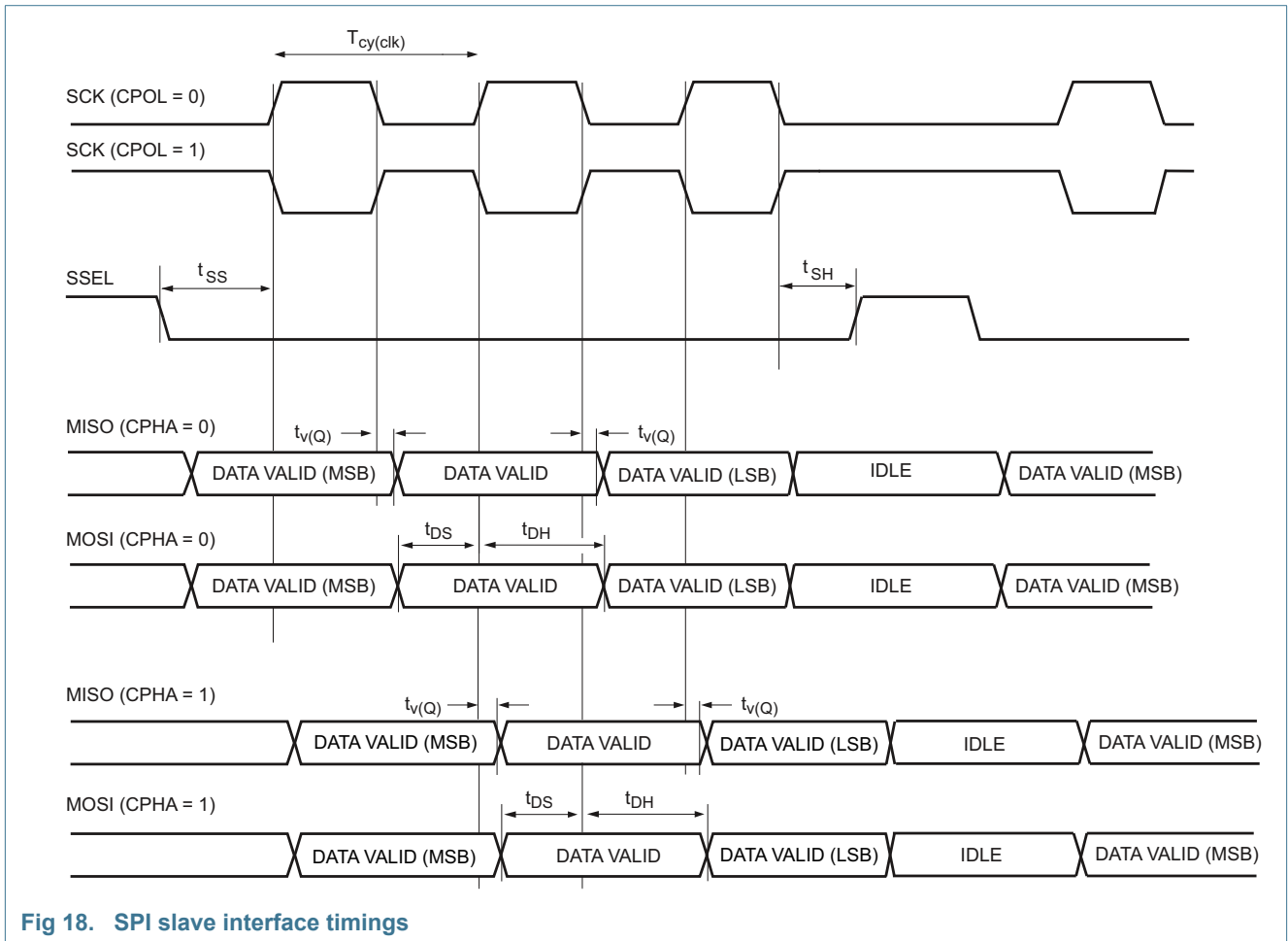

Fig 18. SPI slave interface timings

### 14.7 USART timing

Table 33. USART master timing (in synchronous mode)

$V_{DDE} = 2.4\text{ V to }3.6\text{ V}$ ;  $T_{amb} = -40\text{ }^{\circ}\text{C to }+85\text{ }^{\circ}\text{C}$ ; unless otherwise specified;  $CL = 30\text{ pF}$  balanced loading on all pins; Input slew = 1 ns; SLEW set to standard mode for all pins; Parameters samples at the 90% and 10% level of the rising or falling edge.

Symbol	Parameter	Min	Typ	Max	Unit
$t_{SU(D)}$	Data set-up time	45	—	—	ns
$t_{h(D)}$	Data hold time	5	—	—	ns
$t_{v(Q)}$	Data output valid time	0	—	25	ns
$t_{cy(SCLK)}$	SCLK frequency	—	—	5	MHz

Table 34. USART slave timing (in synchronous mode)

$V_{DDE} = 2.4\text{ V to }3.6\text{ V}$ ;  $T_{amb} = -40\text{ }^{\circ}\text{C to }+85\text{ }^{\circ}\text{C}$ ; unless otherwise specified;  $CL = 30\text{ pF}$  balanced loading on all pins; Input slew = 1 ns; SLEW set to standard mode for all pins; Parameters samples at the 90% and 10% level of the rising or falling edge.

Symbol	Parameter	Min	Typ	Max	Unit
$t_{SU(D)}$	Data set-up time	5	—	—	ns

**Table 34. USART slave timing (in synchronous mode)**

$V_{DDE} = 2.4\text{ V to }3.6\text{ V}$ ;  $T_{amb} = -40\text{ }^{\circ}\text{C to }+85\text{ }^{\circ}\text{C}$ ; unless otherwise specified;  $CL = 30\text{ pF}$  balanced loading on all pins; Input slew =  $1\text{ ns}$ ; SLEW set to standard mode for all pins; Parameters samples at the 90% and 10% level of the rising or falling edge.

Symbol	Parameter	Min	Typ	Max	Unit
$t_{h(D)}$	Data hold time	5	—	—	ns
$t_{v(Q)}$	Data output valid time	0	—	55	ns
$t_{cy(SCLK)}$	SCLK frequency	—	—	5	MHz

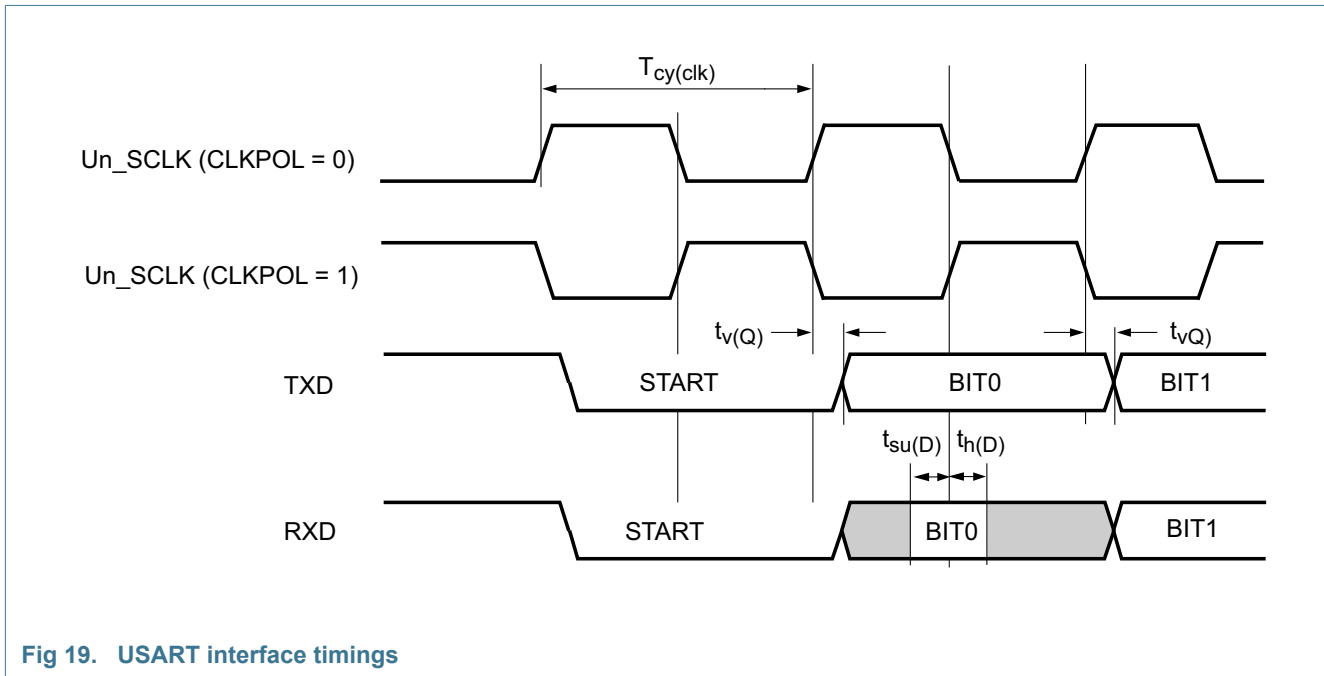

**Fig 19. USART interface timings**

### 14.8 SPIFI timing

**Table 35. SPIFI timing**

$V_{DDE} = 2.4\text{ V to }3.6\text{ V}$ ;  $T_{amb} = -40\text{ }^{\circ}\text{C to }+85\text{ }^{\circ}\text{C}$ ; unless otherwise specified;  $CL = 10\text{ pF}$  balanced loading on all pins; EHS=1 for all pins; Parameters samples at the 90% and 10% level of the rising or falling edge; simulated values.

Symbol	Parameter	Min	Typ	Max	Unit
$t_{cy(clk)}$	Clock cycle time	30.0	—	—	ns
$t_{DS}$	Data set-up time	3	—	—	ns
$t_{DH}$	Data hold time	3	—	—	ns
$t_{v(Q)}$	Data output valid time	—	—	5	ns
$t_{h(Q)}$	Data output hold time	-10.5	—	—	ns
	Duty cycle	40	—	60	%
$t_{SS}$	SSEL set-up time, time SSEL is low before first SCK edge	0.5	—	—	SCK cycles
$t_{SH}$	SSEL hold time, time SSEL is low after last SCK	0.5	—	—	SCK cycles

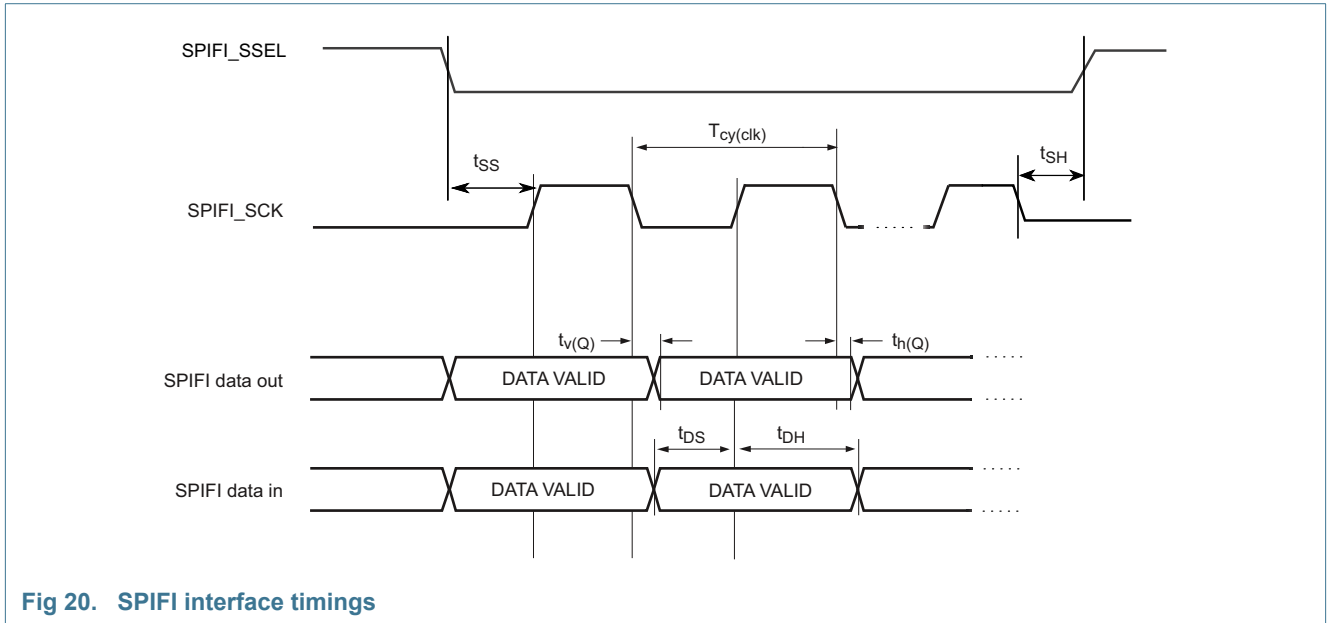

Fig 20. SPIFI interface timings

### 14.9 PWM timing

Table 36. PWM timing

$V_{DDE} = 2.4\text{ V to }3.6\text{ V}$ ;  $T_{amb} = -40\text{ }^{\circ}\text{C to }+85\text{ }^{\circ}\text{C}$ ; unless otherwise specified;  $CL = 10\text{ pF}$  balanced loading on all pins; Input slew = 1ns; SLEW set to standard mode for all pins; parameters samples at the 90% and 10% level of the rising or falling edge; simulated skew (over process, voltage and temperature) of any two PWM output signals; values guaranteed by design.

Symbol	Parameter	Min	Typ	Max	Unit
$t_{sk}$	Output skew time	0	—	10	ns

### 14.10 DMIC timing

Table 37. DMIC timing

$V_{DDE} = 2.4\text{ V to }3.6\text{ V}$ ;  $T_{amb} = -40\text{ }^{\circ}\text{C to }+85\text{ }^{\circ}\text{C}$ ; unless otherwise specified;  $CL = 10\text{ pF}$  balanced loading on all pins; Input slew = 1ns; SLEW set to standard mode for all pins; parameters samples at the 90% and 10% level of the rising or falling edge; bypass bit = 0; based on simulated values and for 2.4 V to 3.6 V.

Symbol	Parameter	Conditions	Min	Typ	Max	Unit
$t_{cy}(SCK)$	DMIC CLK frequency		—	—	2	MHz
	Duty cycle	$CL = 10\text{ pF}$ using 32MHz XTAL clock source	48	—	52	%
$t_{ds}$	Data set-up time		25	—	—	ns
$t_{dh}$	Data hold time		1	—	—	ns

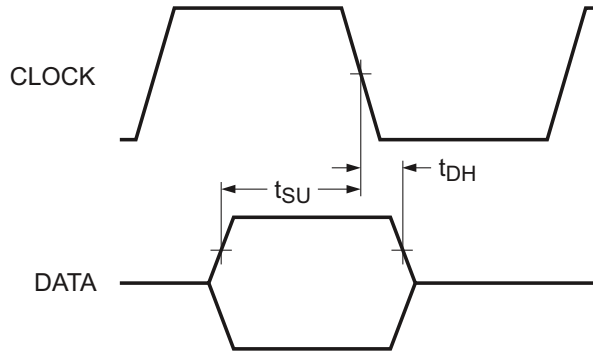

Fig 21. DMIC interface timings

### 14.11 ISO7816

Table 38. Clock of ISO7816

$V_{DDE} = 2.4\text{ V to }3.6\text{ V}$ ;  $T_{amb} = -40\text{ }^{\circ}\text{C to }+85\text{ }^{\circ}\text{C}$ ; unless otherwise specified;  $T_j = -40\text{ }^{\circ}\text{C to }+90\text{ }^{\circ}\text{C}$ ; unless otherwise specified; guaranteed by design; Not tested in production.

Symbol	Parameter	Min	Typ	Max	Unit
$V_{OH}$	High-level output voltage	$0.7 \times V_{BAT}$	—	$V_{BAT}$	V
$V_{OL}$	Low-level output voltage	0	—	$0.3 \times V_{BAT}$	V
	Duty cycle	48	—	52	%
Freq	CLK frequency	2	—	12	MHz

Table 39. Input output of ISO7816

$V_{DDE} = 2.4\text{ V to }3.6\text{ V}$ ;  $T_{amb} = -40\text{ }^{\circ}\text{C to }+85\text{ }^{\circ}\text{C}$ ; unless otherwise specified; unless otherwise specified; guaranteed by design; Not tested in production.

Symbol	Parameter	Conditions	Min	Typ	Max	Unit
$V_{OH}$	High-level output voltage	CL = 10 pF	$0.7 \times V_{BAT}$	—	$V_{BAT}$	V
$V_{OL}$	Low-level output voltage	CL = 10 pF	0	—	$0.3 \times V_{BAT}$	V
$V_{IH}$	High-level input voltage		$0.75 \times V_{BAT}$	—	$V_{BAT} + 0.1$	V
$V_{IL}$	Low-level input voltage	For $V_{BAT}$ from 0 V to 3.6 V	0	—	0.3	V
$I_{OH}$	High-level output current		10	—	1000	$\mu\text{A}$
$I_{OL}$	Low-level output current		600	—	1000	$\mu\text{A}$
$t_{r(O)}$	Output rise time	CL= 30 pF; 10 % to 90 %; 0 V to $V_{BAT}$	—	—	1.2	$\mu\text{s}$
$t_{f(O)}$	Output fall time	CL= 30 pF; 10 % to 90 %; 0 V to $V_{BAT}$	—	—	1.2	$\mu\text{s}$
$t_{r(I)}$	Input rise time		—	—	100	ns
$t_{f(I)}$	Input fall time		—	—	100	ns

## 14.12 I<sup>2</sup>C timing

**Table 40. I<sup>2</sup>C timing**

$V_{DDE} = 2.4\text{ V to }3.6\text{ V}$ ;  $T_{amb} = -40\text{ }^{\circ}\text{C to }+85\text{ }^{\circ}\text{C}$ ; unless otherwise specified; guaranteed by design. Not tested in production.

Symbol	Parameter	Conditions	Min	Typ	Max	Unit
f <sub>SCL</sub>	SC clock frequency	Standard-mode	0	—	100	kHz
		Fast-mode	0	—	400	kHz
		Fast-mode plus	0	—	1	MHz
t <sub>f</sub>	Fall time, of both SDA and SCL signals	Standard-mode	—	—	300	ns
		Fast-mode [8]	20 x V <sub>DDE</sub> /5.5	—	300	ns
		Fast-mode plus	—	—	120	ns
t <sub>LOW</sub>	Low period of the SCL clock	Standard-mode	4.7	—	—	μs
		Fast-mode	1.3	—	—	μs
		Fast-mode plus	0.5	—	—	μs
t <sub>HIGH</sub>	High period of the SCL clock	Standard-mode	4	—	—	μs
		Fast-mode	0.6	—	—	μs
		Fast-mode plus	0.26	—	—	μs
t <sub>HD;DAT</sub>	Data hold time	Standard-mode	0	—	—	ns
		Fast-mode	0	—	—	ns
		Fast-mode plus	0	—	—	ns
t <sub>SU;DAT</sub>	Data setup time	Standard-mode	250	—	—	ns
		Fast-mode	100	—	—	ns
		Fast-mode plus	50	—	—	ns

- [1] t<sub>HD;DAT</sub> is the data hold time that is measured from the falling edge of SCL; applies to data in transmission and the acknowledge.
- [2] A device must internally provide a hold time of at least 300 ns for the SDA signal (with respect to the V<sub>IH</sub>(min) of the SCL signal) to bridge the undefined region of the falling edge of SCL.
- [3] The maximum t<sub>f</sub> for the SDA and SCL bus lines is specified at 300 ns. The maximum fall time for the SDA output stage t<sub>f</sub> is specified at 250 ns. This allows series protection resistors to be connected in between the SDA and the SCL pins and the SDA/SCL bus lines without exceeding the maximum specified t<sub>f</sub>.
- [4] In Fast-mode Plus, fall time is specified the same for both output stage and bus timing. If series resistors are used, designers should allow for this when considering bus timing.
- [5] The maximum t<sub>HD;DAT</sub> could be 3.45 μs and 0.9 μs for Standard-mode and Fast-mode but must be less than the maximum of t<sub>VD;DAT</sub> or t<sub>VD;ACK</sub> by a transition time. This maximum must only be met if the device does not stretch the LOW period (t<sub>LOW</sub>) of the SCL signal. If the clock stretches the SCL, the data must be valid by the set-up time before it releases the clock.
- [6] t<sub>SU;DAT</sub> is the data set-up time that is measured with respect to the rising edge of SCL; applies to data in transmission and the acknowledge.
- [7] A Fast-mode I<sup>2</sup>C-bus device can be used in a Standard-mode I<sup>2</sup>C-bus system but the requirement t<sub>SU;DAT</sub> = 250 ns must then be met. This will automatically be the case if the device does not stretch the LOW period of the SCL signal. If such a device does stretch the LOW period of the SCL signal, it must output the next data bit to the SDA line t<sub>r</sub>(max) + t<sub>SU;DAT</sub> = 1000 + 250 = 1250 ns (according to the Standard-mode I<sup>2</sup>C-bus specification) before the SCL line is released. Also the acknowledge timing must meet this set-up time.
- [8] Valid for I<sup>2</sup>C IO cells. When I<sup>2</sup>C functionality is supported on standard IO cells this Min time is 0.

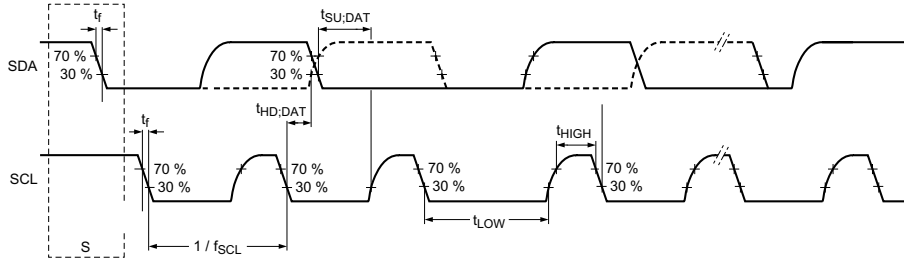

Fig 22. I<sup>2</sup>C interface timings

### 14.13 GPIO pin timing

Table 41. GPIO pin timing

$V_{DDE} = 2.4\text{ V to }3.6\text{ V}$ ;  $T_{amb} = -40\text{ }^{\circ}\text{C to }+85\text{ }^{\circ}\text{C}$ ; unless otherwise specified; Input slew = 1 ns; parameters samples at the 90% and 10% level of the rising or falling edge.

Symbol	Parameter	Conditions	Min	Typ	Max	Unit
	GPIO pin interrupt pulse width (digital glitch filter disabled) - Synchronous path		[1] [2] 1.5	—	—	Bus clock cycles
	GPIO pin interrupt pulse width (digital glitch filter disabled) - Asynchronous path		[3] 20	—	—	ns

[1] This is the minimum pulse width that is guaranteed to pass through the pin synchronization circuitry in run modes (Min CPU clock at 12 MHz)

[2] The greater of synchronous and asynchronous timing must be met

[3] This is the minimum pulse width that is guaranteed to be recognized

### 14.14 Radio transceiver (IEEE 802.15.4)

This K32W041A/K32W041AM meets all the requirements of the IEEE 802.15.4 standard over 2.4 V to 3.6 V and offers the improved RF characteristics shown in [Table 43](#). All RF characteristics are measured single ended.

This part also meets the following regulatory body approvals, when used with NXP’s Module Reference Designs. Compliant with *FCC part 15 rules, IC Canada and ETSI ETS 300-328*, refer to the K32W041A/K32W041AM Module Reference Design package on the Wireless Connectivity area of the NXP web site [Ref. 2](#).

The PCB schematic and layout rules detailed in [Section 9 “Application design-in information”](#) must be followed. Failure to do so will likely result in the K32W041A/K32W041AM failing to meet the performance specification detailed herein and worst case may result in device not functioning in the end application.

Table 42. RF port characteristics

Single-ended; Impedance = 50 Ω;  $V_{DDE} = 2.4\text{ V to }3.6\text{ V}$ ;  $T_{amb} = -40\text{ }^{\circ}\text{C to }+85\text{ }^{\circ}\text{C}$ ; unless otherwise specified.

Symbol	Parameter	Min	Typ	Max	Unit
Frang	Frequency range	2.4	—	2.485	GHz

**Table 43. Radio transceiver characteristics: +25 °C** $V_{DDE} = 2.4\text{ V}$  to  $3.6\text{ V}$ ; unless otherwise specified.

Symbol	Parameter	Conditions	Min	Typ	Max	Unit	
<b>Receiver</b>							
S <sub>RX</sub>	Receiver sensitivity	1 % PER, as per IEEE 802.15.4	—	-99.7	—	dBm	
NF	Noise Figure	Max gain <a href="#">[1]</a>	—	7.3	—	dB	
P <sub>inMaxRX</sub>	Maximum receiver input power	1 % PER, measured as sensitivity	—	—	10	dBm	
C <sub>och</sub>	Co-channel Interference rejection	1 % PER, with wanted signal 3 dB above sensitivity as per IEEE 802.15.4 <a href="#">[2]</a>	—	-2.1	—	dB	
R <sub>ej-5M</sub>	Interference rejection, 1% PER, with wanted signal 3 dB above sensitivity as per IEEE 802.15.4 <a href="#">[2]</a>	Adjacent -5 MHz	—	35.6	—	dB	
R <sub>ej+5M</sub>		Adjacent +5 MHz	—	36	—	dB	
R <sub>ej-10M</sub>		Alternate -10 MHz	—	46.3	—	dB	
R <sub>ej+10M</sub>		Alternate +10 MHz	—	46.7	—	dB	
R <sub>ej-15M</sub>		-15 MHz	—	51.5	—	dB	
R <sub>ej+15M</sub>		+15 MHz	—	52.3	—	dB	
R <sub>ejProp-5M</sub>		Proprietary mode interference rejection. 1% PER, with wanted signal 3 dB above sensitivity as per IEEE 802.15.4 <a href="#">[3]</a>	Adjacent -5 MHz	—	57.1	—	dB
R <sub>ejProp+5M</sub>			Adjacent +5 MHz	—	59.6	—	dB
R <sub>ejProp-10M</sub>			Alternate -10 MHz	—	62.1	—	dB
R <sub>ejProp+10M</sub>			Alternate +10 MHz	—	62.7	—	dB
R <sub>ejProp-15M</sub>	-15 MHz		—	58	—	dB	
R <sub>ejProp+15M</sub>	+15 MHz		—	60.8	—	dB	
R <sub>ejCW-5M</sub>	CW interference rejection. 1% PER, with wanted signal 3 dB above sensitivity as per IEEE 802.15.4 <a href="#">[4]</a>	Adjacent -5 MHz	—	59	—	dB	
R <sub>ejCW+5M</sub>		Adjacent +5 MHz	—	59.7	—	dB	
R <sub>ejCW-10M</sub>		Alternate -10 MHz	—	62	—	dB	
R <sub>ejCW+10M</sub>		Alternate +10 MHz	—	62.6	—	dB	
R <sub>ejCW-15M</sub>		-15 MHz	—	61.1	—	dB	
R <sub>ejCW+15M</sub>		+15 MHz	—	61.5	—	dB	
R <sub>ejOOB</sub>	Out-of-band rejection	1 % PER with wanted signal 3 dB above sensitivity, CW interferers at 868 MHz (KNX), RF/2, 2100 MHz (WCDMA), 2500 MHz (LTE), or RF/3 (3GPP-Japan)	—	61.6	—	dB	
IMP2,4	Inter-modulation protection	1% PER with wanted signal 3 dB above sensitivity, modulated interferers at 2 and 4 channels separation <a href="#">[5]</a>	—	44	—	dB	
IMP3,6		1% PER with wanted signal 3 dB above sensitivity, modulated interferers at 3 and 6 channels separation <a href="#">[5]</a>	—	46.5	—	dB	

**Table 43. Radio transceiver characteristics: +25 °C ...continued** $V_{DDE} = 2.4\text{ V to }3.6\text{ V}$ ; unless otherwise specified.

Symbol	Parameter	Conditions	Min	Typ	Max	Unit
PinBlockin g	Blocking input power	Desired channel IEEE 802.15.4, level = measured sensitivity + 6dB, channels 11 & 26. Unwanted channel CW at 2380 MHz or 2503.5 MHz	—	-20.6	—	dBm
		Desired channel IEEE 802.15.4, level = measured sensitivity + 6dB, channels 11 & 26. Unwanted channel CW at 2300 MHz, 2330 MHz & 2360 MHz	—	-19.5	—	dBm
		Desired channel IEEE 802.15.4, level = measured sensitivity + 6dB, channels 11 & 26. Unwanted channel CW at 2523.5 MHz, 2553.5 MHz, 2583.5 MHz, 2613.5 MHz, 2643.5 MHz, 2673.5 MHz	—	-18.7	—	dBm
RSSIvar	RSSI variation	Desired channel IEEE 802.15.4, over the RSSI range -100 dBm to 8 dBm <a href="#">[6]</a>	—	±2	—	dB
PspRX	Receiver spurious emission, measured conducted into 50 ohms	30 MHz to 1 GHz, 100 kHz RBW, 300 kHz VBW, Filter type 3 dB (Gaussian), Peak detector, Trace Mode Max hold	—	-87.1	—	dBm
		1 GHz to 12.75 GHz, 1 MHz RBW, 3MHz VBW, Filter type 3dB (Gaussian), Peak detector, Trace mode Max hold	—	-70.9	—	dBm
LOLeakRX	Local oscillator leakage power		—	-98	—	dBm
R <sub>ej</sub> WiFi	WiFi rejection	1% PER, with wanted signal IEEE 802.15.4 -75 dBm 2470 MHz, WiFi signal IEEE 802.11n 2447 MHz (20MHz mode)	—	55.6	—	dB
<b>Transmitter</b>						
P <sub>outMax</sub>	Maximum output power	Measured with Wide Band Power Meter	—	15.1	—	dBm
P <sub>out</sub>	Output power in band tilt	At +10 dBm	—	±0.3	—	dB
		At +15 dBm	—	±0.3	—	dB
P <sub>outRange</sub>	Output power control range		—	45.7	—	dB
EVM	Error vector magnitude	With IEEE 802.15.4 channel at +10 dBm	—	6.3	—	%
		With IEEE 802.15.4 channel at +15 dBm	—	6.3	—	%
OEVM	Offset error vector magnitude	With IEEE 802.15.4 channel at +10 dBm	—	0.33	—	%
		With IEEE 802.15.4 channel at +15 dBm	—	0.33	—	%
EVM <sub>Prop</sub>	Error Vector Magnitude	With proprietary mode at +10 dBm	—	23.2	—	%
		With proprietary mode at +15 dBm	—	24.9	—	%
OEVM <sub>Prop</sub>	Offset error Vector Magnitude	With proprietary mode at +10 dBm	—	3.2	—	%
		With proprietary mode at +15 dBm	—	3.7	—	%



**Table 43. Radio transceiver characteristics: +25 °C ...continued** $V_{DDE} = 2.4\text{ V to }3.6\text{ V}$ ; unless otherwise specified.

Symbol	Parameter	Conditions	Min	Typ	Max	Unit
PSD	Power spectral density	Relative density at greater than 3.5 MHz offset as per IEEE 802.15.4 at +10 dBm	—	-37.4	—	dBc
		Absolute density at greater than 3.5 MHz offset at +10 dBm as per IEEE 802.15.4 at +10 dBm	—	-38.2	—	dBm
		Relative density at greater than 3.5 MHz offset as per IEEE 802.15.4 at +15 dBm	—	-37.4	—	dBc
		Absolute density at greater than 3.5 MHz offset at +10 dBm as per IEEE 802.15.4 at +15 dBm	—	-33.2	—	dBm
PSD <sub>Prop</sub>	Proprietary mode power spectral density	Relative density at greater than 3.5 MHz offset with proprietary mode at +10 dBm	—	-61.2	—	dBc
		Absolute density at greater than 3.5 MHz offset with proprietary mode at +10 dBm	—	-62.2	—	dBm
		Relative density at greater than 3.5 MHz offset with proprietary mode at +15 dBm	—	-61.2	—	dBc
		Absolute density at greater than 3.5 MHz offset with proprietary mode at +15 dBm	—	-57.5	—	dBm
TXH2	2nd Harmonic of Transmit Carrier Frequency	With IEEE 802.15.4 channel at +10 dBm	—	-62.4	—	dBm/MHz
		With IEEE 802.15.4 channel at +15 dBm	—	-54	—	dBm/MHz
TXH3	3rd Harmonic of Transmit Carrier Frequency	With IEEE 802.15.4 channel at +10 dBm	—	-73	—	dBm/MHz
		With IEEE 802.15.4 channel at +15 dBm	—	-61	—	dBm/MHz

**Table 43. Radio transceiver characteristics: +25 °C ...continued**

$V_{DDE} = 2.4\text{ V to }3.6\text{ V}$ ; unless otherwise specified.

Symbol	Parameter	Conditions	Min	Typ	Max	Unit
PspTX	Transmitter spurious emission, measured conducted into 50 ohms	30 MHz to 1 GHz, Peak detector, RBW=100 kHz	—	-80	—	dBm
		1 GHz to 26 GHz, Peak detector, RBW 1MHz, based on FCC at +10 dBm	—	-22.1	—	dBm
		1 GHz to 26 GHz, Peak detector, RBW 1MHz, based on FCC with proprietary mode at +10 dBm	—	-37.1	—	dBm
		1 GHz to 12.75 GHz, Peak detector, RBW 1MHz, based on ETSI at +10 dBm	—	-39.8	—	dBm
		1 GHz to 12.75 GHz, Peak detector, RBW 1MHz, based on ETSI with proprietary mode at +10 dBm	—	-44	—	dBm
		1 GHz to 26 GHz, Average detector, RBW = 1 MHz, based on FCC at +10 dBm	—	-27.9	—	dBm
		1 GHz to 26 GHz, Average detector, RBW = 1 MHz with proprietary mode, based on FCC at +10 dBm	—	-45.3	—	dBm
		1 GHz to 26 GHz, Peak detector, RBW 1MHz, based on FCC at +15 dBm	—	-16.9	—	dBm
		1 GHz to 26 GHz, Peak detector, RBW 1MHz, based on FCC with proprietary mode at +15 dBm	—	-33	—	dBm
		1 GHz to 12.75 GHz, Peak detector, RBW 1MHz, based on ETSI at +15 dBm	—	-39.1	—	dBm
		1 GHz to 12.75 GHz, Peak detector, RBW 1MHz, based on ETSI with proprietary mode at +15 dBm	—	-39.2	—	dBm
		1 GHz to 26 GHz, Average detector, RBW = 1 MHz, based on FCC at +15 dBm	—	-23.7	—	dBm
		1 GHz to 26 GHz, Average detector, RBW = 1 MHz with proprietary mode, based on FCC at +15 dBm	—	-45.1	—	dBm
		Transmitter spurious emission, ETSI exceptions	1.8 GHz to 1.9 GHz	—	-58	—
5.15 GHz to 5.3 GHz	—		-56.4	—	dBm	

- [1] Considering an integrated BW of 2 MHz, and a minimum SNR of 4 dB for the demodulator.
- [2] Interference rejection is defined as the value, when 1 % PER is seen with the wanted signal 3 dB above sensitivity, with a modulated interferer as per IEEE 802.15.4.
- [3] Proprietary mode interference rejection is defined as the value, when 1 % PER is seen with the wanted signal 3 dB above sensitivity, with a proprietary mode interferer.
- [4] CW Interference rejection is defined as the value, when 1 % PER is seen with the wanted signal 3 dB above sensitivity, with a CW interferer.
- [5] The intermodulation protection level is the difference between the wanted channel power and one of the two interferers power. Both interferers are modulated as per IEEE 802.15.4 and have the same power.
- [6] This RSSI variation over temperature is obtained with the use of the embedded thermometer and the integrated API (see application note).

**Table 44. Radio transceiver characteristics: -40 °C** $V_{DDE} = 2.4\text{ V to }3.6\text{ V}$ ; unless otherwise specified.

Symbol	Parameter	Conditions	Min	Typ	Max	Unit	
<b>Receiver</b>							
S <sub>RX</sub>	Receiver sensitivity	1 % PER, as per IEEE 802.15.4	—	-101.3	—	dBm	
NF	Noise Figure	Max gain <a href="#">[1]</a>	—	5.7	—	dB	
P <sub>inMaxRX</sub>	Maximum receiver input power	1 % PER, measured as sensitivity	—	—	10	dBm	
Co <sub>ch</sub>	Co-channel Interference rejection	1 % PER, with wanted signal 3 dB, above sensitivity as per IEEE 802.15.4 <a href="#">[2]</a>	—	-2	—	dB	
R <sub>ej-5M</sub>	Interference rejection, 1% PER, with wanted signal 3 dB above sensitivity as per IEEE 802.15.4 <a href="#">[2]</a>	Adjacent -5 MHz	—	35.9	—	dB	
R <sub>ej+5M</sub>		Adjacent +5 MHz	—	35.8	—	dB	
R <sub>ej-10M</sub>		Alternate -10 MHz	—	46.5	—	dB	
R <sub>ej+10M</sub>		Alternate +10 MHz	—	46.6	—	dB	
R <sub>ej-15M</sub>		-15 MHz	—	51.6	—	dB	
R <sub>ej+15M</sub>		+15 MHz	—	52.1	—	dB	
R <sub>ejProp-5M</sub>		Proprietary mode interference rejection. 1% PER, with wanted signal 3 dB above sensitivity as per IEEE 802.15.4 <a href="#">[3]</a>	Adjacent -5 MHz	—	56.4	—	dB
R <sub>ejProp+5M</sub>			Adjacent +5 MHz	—	60.4	—	dB
R <sub>ejProp-10M</sub>			Alternate -10 MHz	—	60.6	—	dB
R <sub>ejProp+10M</sub>			Alternate +10 MHz	—	61.3	—	dB
R <sub>ejProp-15M</sub>	-15 MHz		—	56.5	—	dB	
R <sub>ejProp+15M</sub>	+15 MHz		—	59.2	—	dB	
R <sub>ejCW-5M</sub>	CW interference rejection. 1% PER, with wanted signal 3 dB above sensitivity as per IEEE 802.15.4 <a href="#">[4]</a>	Adjacent -5 MHz	—	56.8	—	dB	
R <sub>ejCW+5M</sub>		Adjacent +5 MHz	—	60.4	—	dB	
R <sub>ejCW-10M</sub>		Alternate -10 MHz	—	60.4	—	dB	
R <sub>ejCW+10M</sub>		Alternate +10 MHz	—	60.9	—	dB	
R <sub>ejCW-15M</sub>		-15 MHz	—	59.9	—	dB	
R <sub>ejCW+15M</sub>		+15 MHz	—	60.7	—	dB	
R <sub>ejOOB</sub>	Out-of-band rejection	1 % PER with wanted signal 3 dB above sensitivity, CW interferers at 868 MHz (KNX), RF/2, 2100 MHz (WCDMA), 2500 MHz (LTE), or RF/3 (3GPP-Japan)	—	61.7	—	dB	
IMP2,4	Inter-modulation protection	1% PER with wanted signal 3 dB above sensitivity, modulated interferers at 2 and 4 channels separation <a href="#">[5]</a>	—	42.5	—	dB	
IMP3,6		1% PER with wanted signal 3 dB above sensitivity, modulated interferers at 3 and 6 channels separation <a href="#">[5]</a>	—	46.5	—	dB	

**Table 44. Radio transceiver characteristics: -40 °C ...continued** $V_{DDE} = 2.4\text{ V to }3.6\text{ V}$ ; unless otherwise specified.

Symbol	Parameter	Conditions	Min	Typ	Max	Unit
PinBlockin g	Blocking input power	Desired channel IEEE 802.15.4, level = measured sensitivity + 6dB, channels 11 & 26. Unwanted channel CW at 2380 MHz or 2503.5 MHz	—	-22	—	dBm
		Desired channel IEEE 802.15.4, level = measured sensitivity + 6dB, channels 11 & 26. Unwanted channel CW at 2300 MHz, 2330 MHz & 2360 MHz	—	-21.2	—	dBm
		Desired channel IEEE 802.15.4, level = measured sensitivity + 6dB, channels 11 & 26. Unwanted channel CW at 2523.5 MHz, 2553.5 MHz, 2583.5 MHz, 2613.5 MHz, 2643.5 MHz, 2673.5 MHz	—	-20.4	—	dBm
RSSIvar	RSSI variation	Desired channel IEEE 802.15.4, over the RSSI range -101 dBm to +9 dBm <a href="#">[6]</a>	—	±2	—	dB
PspRX	Receiver spurious emission, measured conducted into 50 ohms	30 MHz to 1 GHz, 100 kHz RBW, 300 kHz VBW, Filter type 3 dB (Gaussian), Peak detector, Trace Mode Max hold	—	-83.3	—	dBm
		1 GHz to 12.75 GHz, 1 MHz RBW, 3MHz VBW, Filter type 3dB (Gaussian), Peak detector, Trace mode Max hold	—	-62.7	—	dBm
LOLeakRX	Local oscillator leakage power		—	-98	—	dBm
R <sub>ej</sub> WiFi	WiFi rejection	1 % PER, with wanted signal IEEE 802.15.4 -75 dBm 2470 MHz, WiFi signal IEEE 802.11n 2447 MHz (20MHz mode)	—	53.7	—	dB
<b>Transmitter</b>						
P <sub>out</sub> Max	Maximum output power	Measured with Wide Band Power Meter	—	15.5	—	dBm
P <sub>out</sub>	Output power in band tilt	at +10 dBm	—	±0.3	—	dB
		at +15 dBm	—	±0.3	—	dB
P <sub>out</sub> Range	Output power control range		—	46.6	—	dB
EVM	Error vector magnitude	With IEEE 802.15.4 channel at +10 dBm	—	6.6	—	%
		With IEEE 802.15.4 channel at +15 dBm	—	6.0	—	%
OEVM	Offset error vector magnitude	With IEEE 802.15.4 channel at +10 dBm	—	0.36	—	%
		With IEEE 802.15.4 channel at +15 dBm	—	0.30	—	%
EVM <sub>Prop</sub>	Error Vector Magnitude	With proprietary mode at +10 dBm	—	22.5	—	%
		With proprietary mode at +15 dBm	—	23.2	—	%
OEVM <sub>Prop</sub>	Offset error Vector Magnitude	With proprietary mode at +10 dBm	—	3.1	—	%
		With proprietary mode at +15 dBm	—	3.1	—	%

**Table 44. Radio transceiver characteristics: -40 °C ...continued** $V_{DDE} = 2.4\text{ V to }3.6\text{ V}$ ; unless otherwise specified.

Symbol	Parameter	Conditions	Min	Typ	Max	Unit
PSD	Power spectral density	Relative density at greater than 3.5 MHz offset as per IEEE 802.15.4 at +10 dBm	—	-37.3	—	dBc
		Absolute density at greater than 3.5 MHz offset at +10 dBm as per IEEE 802.15.4 at +10 dBm	—	-37.7	—	dBm
		Relative density at greater than 3.5 MHz offset as per IEEE 802.15.4 at +15 dBm	—	-37.3	—	dBc
		Absolute density at greater than 3.5 MHz offset at +10 dBm as per IEEE 802.15.4 at +15 dBm	—	-32.7	—	dBm
PSD <sub>Prop</sub>	Proprietary mode power spectral density	Relative density at greater than 3.5 MHz offset with proprietary mode at +10 dBm	—	-61.2	—	dBc
		Absolute density at greater than 3.5 MHz offset with proprietary mode at +10 dBm	—	-61.9	—	dBm
		Relative density at greater than 3.5 MHz offset with proprietary mode at +15 dBm	—	-61.2	—	dBc
		Absolute density at greater than 3.5 MHz offset with proprietary mode at +15 dBm	—	-57.3	—	dBm
TXH2	2nd Harmonic of Transmit Carrier Frequency	With IEEE 802.15.4 channel at +10 dBm	—	-61.6	—	dBm/MHz
		With IEEE 802.15.4 channel at +15 dBm	—	-54.5	—	dBm/MHz
TXH3	3rd Harmonic of Transmit Carrier Frequency	With IEEE 802.15.4 channel at +10 dBm	—	-73	—	dBm/MHz
		With IEEE 802.15.4 channel at +15 dBm	—	-62.5	—	dBm/MHz

**Table 44. Radio transceiver characteristics: -40 °C ...continued**

$V_{DDE} = 2.4\text{ V to }3.6\text{ V}$ ; unless otherwise specified.

Symbol	Parameter	Conditions	Min	Typ	Max	Unit
PspTX	Transmitter spurious emission, measured conducted into 50 ohms	30 MHz to 1 GHz, Peak detector, RBW=100kHz	—	-76.7	—	dBm
		1 GHz to 26 GHz, Peak detector, RBW 1MHz, based on FCC at +10 dBm	—	-21.6	—	dBm
		1 GHz to 26 GHz, Peak detector, RBW 1MHz, based on FCC with proprietary mode at +10 dBm	—	-37.3	—	dBm
		1 GHz to 12.75 GHz, Peak detector, RBW 1MHz, based on ETSI at +10 dBm	—	-39.6	—	dBm
		1 GHz to 12.75 GHz, Peak detector, RBW 1MHz, based on ETSI with proprietary mode at +10 dBm	—	-44	—	dBm
		1 GHz to 26 GHz, Average detector, RBW = 1 MHz, based on FCC at +10 dBm	—	-27.3	—	dBm
		1 GHz to 26 GHz, Average detector, RBW = 1 MHz with proprietary mode, based on FCC at +10 dBm	—	-46.1	—	dBm
		1 GHz to 26 GHz, Peak detector, RBW 1MHz, based on FCC at +15 dBm	—	-17.1	—	dBm
		1 GHz to 26 GHz, Peak detector, RBW 1MHz, based on FCC with proprietary mode at +15 dBm	—	-32.5	—	dBm
		1 GHz to 12.75 GHz, Peak detector, RBW 1MHz, based on ETSI at +15 dBm	—	-39.1	—	dBm
		1 GHz to 12.75 GHz, Peak detector, RBW 1MHz, based on ETSI with proprietary mode at +15 dBm	—	-38.9	—	dBm
		1 GHz to 26 GHz, Average detector, RBW = 1 MHz, based on FCC at +15 dBm	—	-23.8	—	dBm
		1 GHz to 26 GHz, Average detector, RBW = 1 MHz with proprietary mode, based on FCC at +15 dBm	—	-45.1	—	dBm
	Transmitter spurious emission, ETSI exceptions	1.8 GHz to 1.9 GHz	—	-58.4	—	dBm
5.15 GHz to 5.3 GHz		—	-56.8	—	dBm	

- [1] Considering an integrated BW of 2 MHz, and a minimum SNR of 4 dB for the demodulator.
- [2] Interference rejection is defined as the value, when 1% PER is seen with the wanted signal 3 dB above sensitivity, with a modulated interferer as per IEEE 802.15.4.
- [3] Proprietary mode interference rejection is defined as the value, when 1 % PER is seen with the wanted signal 3 dB above sensitivity, with a proprietary mode interferer.
- [4] CW Interference rejection is defined as the value, when 1 % PER is seen with the wanted signal 3 dB above sensitivity, with a CW interferer.
- [5] The intermodulation protection level is the difference between the wanted channel power and one of the two interferers power. Both interferers are modulated as per IEEE 802.15.4 and have the same power.
- [6] This RSSI variation over temperature is obtained with the use of the embedded thermometer and the integrated API (see application note).

**Table 45. Radio transceiver characteristics: +85 °C** $V_{DDE} = 2.4\text{ V to }3.6\text{ V}$ ; unless otherwise specified.

Symbol	Parameter	Conditions	Min	Typ	Max	Unit	
<b>Receiver</b>							
$S_{RX}$	receiver sensitivity	1 % PER, as per IEEE 802.15.4	—	-97.1	—	dBm	
NF	Noise Figure	Max gain <a href="#">[1]</a>	—	9.9	—	dB	
$P_{inMaxRX}$	Maximum receiver input power	1 % PER, measured as sensitivity	—	—	10	dBm	
$C_{och}$	Co-channel Interference rejection	1 % PER, with wanted signal 3 dB, above sensitivity as per IEEE 802.15.4 <a href="#">[2]</a>	—	-2.4	—	dB	
$R_{ej-5M}$	Interference rejection, 1% PER, with wanted signal 3 dB above sensitivity as per IEEE 802.15.4 <a href="#">[2]</a>	Adjacent -5 MHz	—	35.4	—	dB	
$R_{ej+5M}$		Adjacent +5 MHz	—	35.8	—	dB	
$R_{ej-10M}$		Alternate -10 MHz	—	46.3	—	dB	
$R_{ej+10M}$		Alternate +10 MHz	—	46.5	—	dB	
$R_{ej-15M}$		-15 MHz	—	51.7	—	dB	
$R_{ej+15M}$		+15 MHz	—	52.1	—	dB	
$R_{ejProp-5M}$		Proprietary mode interference rejection. 1% PER, with wanted signal 3 dB above sensitivity as per IEEE 802.15.4 <a href="#">[3]</a>	Adjacent -5 MHz	—	54.7	—	dB
$R_{ejProp+5M}$			Adjacent +5 MHz	—	56.8	—	dB
$R_{ejProp-10M}$			Alternate -10 MHz	—	59.9	—	dB
$R_{ejProp+10M}$			Alternate +10 MHz	—	63.3	—	dB
$R_{ejProp-15M}$	-15 MHz		—	60.3	—	dB	
$R_{ejProp+15M}$	+15 MHz		—	65.4	—	dB	
$R_{ejCW-5M}$	CW interference rejection. 1% PER, with wanted signal 3 dB above sensitivity as per IEEE 802.15.4 <a href="#">[4]</a>	Adjacent -5 MHz	—	56.1	—	dB	
$R_{ejCW+5M}$		Adjacent +5 MHz	—	57.6	—	dB	
$R_{ejCW-10M}$		Alternate -10 MHz	—	62.9	—	dB	
$R_{ejCW+10M}$		Alternate +10 MHz	—	64	—	dB	
$R_{ejCW-15M}$		-15 MHz	—	62.3	—	dB	
$R_{ejCW+15M}$		+15 MHz	—	65.3	—	dB	
$R_{ejOOB}$	Out-of-band rejection	1 % PER with wanted signal 3 dB above sensitivity, CW interferers at 868 MHz (KNX), RF/2, 2100 MHz (WCDMA), 2500 MHz (LTE), or RF/3 (3GPP-Japan)	—	60.8	—	dB	
IMP2,4	Inter-modulation protection	1% PER with wanted signal 3 dB above sensitivity, modulated interferers at 2 and 4 channels separation <a href="#">[5]</a>	—	44.8	—	dB	
IMP3,6		1% PER with wanted signal 3 dB above sensitivity, modulated interferers at 3 and 6 channels separation <a href="#">[5]</a>	—	47	—	dB	

**Table 45. Radio transceiver characteristics: +85 °C ...continued** $V_{DDE} = 2.4\text{ V to }3.6\text{ V}$ ; unless otherwise specified.

Symbol	Parameter	Conditions	Min	Typ	Max	Unit
PinBlocking	Blocking input power	Desired channel IEEE 802.15.4, level = measured sensitivity + 6 dB, channels 11 & 26. Unwanted channel CW at 2380 MHz or 2503.5 MHz	—	-20	—	dBm
		Desired channel IEEE 802.15.4, level = measured sensitivity + 6 dB, channels 11 & 26. Unwanted channel CW at 2300 MHz, 2330 MHz & 2360 MHz	—	-17.2	—	dBm
		Desired channel IEEE 802.15.4, level = measured sensitivity + 6dB, channels 11 & 26. Unwanted channel CW at 2523.5 MHz, 2553.5 MHz, 2583.5 MHz, 2613.5 MHz, 2643.5 MHz, 2673.5 MHz	—	-16.3	—	dBm
RSSIvar	RSSI variation	Desired channel IEEE 802.15.4, over the RSSI range -97 dBm to +5 dBm <a href="#">[6]</a>	—	±2	—	dB
PspRX	Receiver spurious emission, Measured conducted into 50 ohms	30 MHz to 1 GHz, 100 kHz RBW, 300 kHz VBW, Filter type 3 dB (Gaussian), Peak detector, Trace Mode Max hold	—	-87.7	—	dBm
		1 GHz to 12.75 GHz, 1 MHz RBW, 3MHz VBW, Filter type 3dB (Gaussian), Peak detector, Trace mode Max hold	—	-64.9	—	dBm
LOLeakRX	Local oscillator leakage power		—	-98	—	dBm
R <sub>ej</sub> WiFi	WiFi rejection	1 % PER, with wanted signal IEEE 802.15.4 -75 dBm 2470 MHz, WiFi signal IEEE 802.11n 2447 MHz (20MHz mode)	—	51.1	—	dB
<b>Transmitter</b>						
P <sub>outMax</sub>	Maximum output power	Measured with Wide Band Power Meter	—	14.6	—	dBm
P <sub>out</sub>	Output power in band tilt	At +10 dBm	—	±0.3	—	dB
		At +15 dBm	—	±0.3	—	dB
P <sub>outRange</sub>	Output power control range		—	46.8	—	dB
EVM	Error vector magnitude	With IEEE 802.15.4 channel at +10 dBm	—	6.6	—	%
		With IEEE 802.15.4 channel at +15 dBm	—	6.2	—	%
OEVM	Offset error vector magnitude	With IEEE 802.15.4 channel at +10 dBm	—	0.36	—	%
		With IEEE 802.15.4 channel at +15 dBm	—	0.36	—	%
EVM <sub>Prop</sub>	Error Vector Magnitude	With proprietary mode at +10 dBm	—	23	—	%
		With proprietary mode at +15 dBm	—	23	—	%
OEVM <sub>Prop</sub>	Offset error Vector Magnitude	With proprietary mode at +10 dBm	—	3.2	—	%
		With proprietary mode at +15 dBm	—	3.2	—	%



**Table 45. Radio transceiver characteristics: +85 °C ...continued**

$V_{DDE} = 2.4\text{ V to }3.6\text{ V}$ ; unless otherwise specified.

Symbol	Parameter	Conditions	Min	Typ	Max	Unit
PSD	Power spectral density	Relative density at greater than 3.5 MHz offset as per IEEE 802.15.4 at +10 dBm	—	-37.5	—	dBc
		Absolute density at greater than 3.5 MHz offset at +10 dBm as per IEEE 802.15.4 at +10 dBm	—	-39.5	—	dBm
		Relative density at greater than 3.5 MHz offset as per IEEE 802.15.4 at +15 dBm	—	-37.5	—	dBc
		Absolute density at greater than 3.5 MHz offset at +10 dBm as per IEEE 802.15.4 at +15 dBm	—	-33.7	—	dBm
PSD <sub>Prop</sub>	Proprietary mode power spectral density	Relative density at greater than 3.5 MHz offset with proprietary mode at +10 dBm	—	-60.6	—	dBc
		Absolute density at greater than 3.5 MHz offset with proprietary mode at +10 dBm	—	-62.8	—	dBm
		Relative density at greater than 3.5 MHz offset with proprietary mode at +15 dBm	—	-60.6	—	dBc
		Absolute density at greater than 3.5 MHz offset with proprietary mode at +15 dBm	—	-57.4	—	dBm
TXH2	2nd Harmonic of Transmit Carrier Frequency	With IEEE 802.15.4 channel at +10 dBm	—	-63.3	—	dBm/MHz
		With IEEE 802.15.4 channel at +15 dBm	—	-56.4	—	dBm/MHz
TXH3	3rd Harmonic of Transmit Carrier Frequency	With IEEE 802.15.4 channel at +10 dBm	—	-73	—	dBm/MHz
		With IEEE 802.15.4 channel at +15 dBm	—	-63.6	—	dBm/MHz

**Table 45. Radio transceiver characteristics: +85 °C ...continued**

$V_{DDE} = 2.4\text{ V to }3.6\text{ V}$ ; unless otherwise specified.

Symbol	Parameter	Conditions	Min	Typ	Max	Unit
PspTX	Transmitter spurious emission, measured conducted into 50 ohms	30 MHz to 1 GHz, Peak detector, RBW=100kHz	—	-76.3	—	dBm
		1 GHz to 26 GHz, Peak detector, RBW 1MHz, based on FCC at +10 dBm	—	-23.3	—	dBm
		1 GHz to 26 GHz, Peak detector, RBW 1MHz, based on FCC with proprietary mode at +10 dBm	—	-39	—	dBm
		1 GHz to 12.75 GHz, Peak detector, RBW 1MHz, based on ETSI at +10 dBm	—	-41.3	—	dBm
		1 GHz to 12.75 GHz, Peak detector, RBW 1MHz, based on ETSI with proprietary mode at +10 dBm	—	-44.3	—	dBm
		1 GHz to 26 GHz, Average detector, RBW = 1 MHz, based on FCC at +10 dBm	—	-29.2	—	dBm
		1 GHz to 26 GHz, Average detector, RBW = 1 MHz with proprietary mode, based on FCC at +10 dBm	—	-46.3	—	dBm
		1 GHz to 26 GHz, Peak detector, RBW 1MHz, based on FCC at +15 dBm	—	-18.4	—	dBm
		1 GHz to 26 GHz, Peak detector, RBW 1MHz, based on FCC with proprietary mode at +15 dBm	—	-35.3	—	dBm
		1 GHz to 12.75 GHz, Peak detector, RBW 1MHz, based on ETSI at +15 dBm	—	-42.4	—	dBm
		1 GHz to 12.75 GHz, Peak detector, RBW 1MHz, based on ETSI with proprietary mode at +15 dBm	—	-42.1	—	dBm
		1 GHz to 26 GHz, Average detector, RBW = 1 MHz, based on FCC at +15 dBm	—	-25.6	—	dBm
		1 GHz to 26 GHz, Average detector, RBW = 1 MHz with proprietary mode, based on FCC at +15 dBm	—	-46.9	—	dBm
		Transmitter spurious emission, ETSI exceptions	1.8 GHz to 1.9 GHz	—	-57.9	—
5.15 GHz to 5.3 GHz	—		-56.7	—	dBm	

- [1] Considering an integrated BW of 2 MHz, and a minimum SNR of 4 dB for the demodulator.
- [2] Interference rejection is defined as the value, when 1 % PER is seen with the wanted signal 3 dB above sensitivity, with a modulated interferer as per IEEE 802.15.4.
- [3] Proprietary mode interference rejection is defined as the value, when 1 % PER is seen with the wanted signal 3 dB above sensitivity, with a proprietary mode interferer.
- [4] CW Interference rejection is defined as the value, when 1 % PER is seen with the wanted signal 3 dB above sensitivity, with a CW interferer.
- [5] The intermodulation protection level is the difference between the wanted channel power and one of the two interferers power. Both interferers are modulated as per IEEE 802.15.4 and have the same power.

[6] This RSSI variation over temperature is obtained with the use of the embedded thermometer and the integrated API (see application note).

### 14.15 Radio transceiver (Bluetooth Low Energy)

This K32W041A/K32W041AM meets all the requirements of the Bluetooth Low Energy standard over 2.4 V to 3.6 V and offers the improved RF characteristics shown in [Table 43](#). All RF characteristics are measured single ended.

This part also meets the following regulatory body approvals, when used with NXP’s Module Reference Designs. Compliant with *FCC part 15 rules, IC Canada and ETSI ETS 300-328*, refer to the K32W041A/K32W041AM Module Reference Design package on the Wireless Connectivity area of the NXP web site [Ref. 2](#).

The PCB schematic and layout rules detailed in [Section 9 “Application design-in information”](#) must be followed. Failure to do so will likely result in the K32W041A/K32W041AM failing to meet the performance specification detailed herein and worst case may result in device not functioning in the end application.

**Table 46. RF port characteristics**

Single-ended; Impedance = 50 Ω;  $V_{DD} = 2.4\text{ V to }3.6\text{ V}$ ;  $T_{amb} = -40^{\circ}\text{C to }+85^{\circ}\text{C}$ ; unless otherwise specified.

Symbol	Parameter	Min	Typ	Max	Unit
Frang	Frequency range	2.4	—	2.485	GHz

**Table 47. Radio transceiver characteristics: +25 °C**

$V_{DDE} = 2.4\text{ V to }3.6\text{ V}$ ; unless otherwise specified.

Symbol	Parameter	Conditions	Min	Typ	Max	Unit
<b>Receiver Bluetooth Low Energy 1 Mb/s</b>						
$S_{RX\_BLE\_1M}$	Receiver sensitivity	0.1% BER	—	-97	—	dBm
$NF\_BLE\_1M$	Noise figure	Max gain <a href="#">[1]</a>	—	7	—	dB
$P_{inMaxRX\_BLE\_1M}$	Maximum receiver input power	0.1% BER	—	—	10	dBm
$Co_{ch\_BLE\_1M}$	Co-channel Interference rejection	0.1% BER, with wanted channel at -67 dBm <a href="#">[2]</a>	—	-7	—	dB
$R_{ej-1M\_BLE\_1M}$	Interference rejection, 0.1% BER, with wanted channel at -67 dBm <a href="#">[2]</a>	Channel -1 MHz	—	2.5	—	dB
$R_{ej+1M\_BLE\_1M}$		Channel +1 MHz	—	5.2	—	dB
$R_{ej-2M\_BLE\_1M}$		Channel -2 MHz	—	29	—	dB
$R_{ej+2M\_BLE\_1M}$		Channel +2 MHz	—	44	—	dB
$R_{ej-3M\_BLE\_1M}$		Channel $\leq -3\text{ MHz}$	—	36	—	dB
$R_{ej+3M\_BLE\_1M}$		Channel $\geq +3\text{ MHz}$	—	46	—	dB

**Table 47. Radio transceiver characteristics: +25 °C ...continued**

$V_{DDE} = 2.4\text{ V to }3.6\text{ V}$ ; unless otherwise specified.

Symbol	Parameter	Conditions	Min	Typ	Max	Unit
R <sub>ej</sub> OOB_BLE_1M	Out-of-band blocking	From 30 MHz to 2000 MHz, wanted channel Bluetooth Low Energy 1 Mb/s at -67 dBm, 0.1% BER, CW interferer.	—	0	—	dBm
		From 2003 MHz to 2399 MHz and 2484 MHz [3] to 2999 MHz, wanted signal at -67 dBm, 0.1% BER, CW interferer.	—	0	—	dBm
		From 3000 MHz to 12750 MHz, wanted signal at -67 dBm, 0.1% BER, CW interferer.	—	0	—	dBm
IMP3,6_BLE_1M	Inter-modulation	With CW interferer at ± 3 MHz and Bluetooth Low Energy interferer 1 Mb/s at ± 6 MHz, wanted channel Bluetooth Low Energy 1 Mb/s at -64 dBm, 0.1% BER	—	-27	—	dBm
IMP4,8_BLE_1M		With CW interferer at ± 4 MHz and Bluetooth Low Energy interferer 1 Mb/s at ± 8 MHz, wanted channel Bluetooth Low Energy 1 Mb/s at -64 dBm, 0.1% BER	—	-29	—	dBm
IMP5,10_BLE_1M		With CW interferer at ± 5 MHz and Bluetooth Low Energy interferer 1 Mb/s at ± 10 MHz, wanted channel Bluetooth Low Energy 1 Mb/s at -64 dBm, 0.1% BER	—	-30	—	dBm
PinBlock_BLE_1M	Blocking input power	Desired channel Bluetooth Low Energy 1 Mb/s, level = measured sensitivity + 6dB. Unwanted channel CW at 2380 MHz, or 2503.5 MHz	—	-24	—	dBm
		Desired channel Bluetooth Low Energy 1 Mb/s, level = measured sensitivity + 6dB, channels 0 and 39. Unwanted channel CW at 2300 MHz, 2330 MHz, or 2360 MHz	—	-21	—	dBm
		Desired channel Bluetooth Low Energy 1 Mb/s, level = measured sensitivity + 6dB, channels 0 and 39. Unwanted channel CW at 2523.5 MHz, 2553.5 MHz, 2583.5 MHz, 2613.5 MHz, 2643.5 MHz, or 2673.5 MHz	—	-19	—	dBm
RSSlvar_BLE_1M	RSSI variation	Desired channel Bluetooth Low Energy 1 Mbps, over the RSSI range -97 dBm to +5 dBm	—	±2	—	dB
PspRX_BLE_1M	Receiver spurious emission, measured conducted into 50 ohms	30 MHz to 1 GHz, 100 kHz RBW, 300 kHz VBW, filter type 3 dB (Gaussian), peak detector, trace mode Max hold	—	-80	—	dBm
		1 GHz to 12.75 GHz, 1 MHz RBW, 3 MHz VBW, filter type 3 dB (Gaussian), peak detector, trace mode Max hold	—	-67	—	dBm
LOLeakRX_BLE_1M	Local oscillator leakage power		—	-98	—	dBm
R <sub>ej</sub> WIFI_BLE_1M	WIFI rejection	0.1% BER, with wanted signal Bluetooth Low Energy 1 Mb/s -67 dBm 2470 MHz, WIFI signal IEEE 802.11n 2447 MHz (20 MHz mode)	—	42	—	dB

**Transmitter Bluetooth Low Energy 1 Mb/s**

**Table 47. Radio transceiver characteristics: +25 °C ...continued** $V_{DDE} = 2.4\text{ V to }3.6\text{ V}$ ; unless otherwise specified.

Symbol	Parameter	Conditions	Min	Typ	Max	Unit
$P_{outMax\_BLE\_1M}$	Maximum output power	Measured with CMWxxx equipment	—	14.3	—	dBm
$P_{out\_BLE\_1M}$	Output power in band tilt	At +10 dBm	—	$\pm 0.2$	—	dB
		At +15 dBm	—	$\pm 0.2$	—	dB
$P_{outRange\_BLE\_1M}$	Output power control range		—	47.3	—	dB
$TxAdj2M\_BLE\_1M$	Bluetooth Low Energy adjacent channel transmit Power at 2 MHz offset		—	-43.7	—	dBm
$TxAdj3M\_BLE\_1M$	Bluetooth Low Energy adjacent channel transmit Power at $\geq 3$ MHz offset		—	-46.6	—	dBm
$\Delta f_{1avg\_BLE\_1M}$	Average frequency deviation using a 00001111 sequence		—	249	—	kHz
$\Delta f_{299\_9\_BLE\_1M}$	99.9% of absolute peak frequency deviation using a 10101010 sequence		—	207	—	kHz
$\Delta f_{2avg}/\Delta f_{1avg\_BLE\_1M}$	Ratio of average frequency deviation using a 10101010 sequence, and average frequency deviation using a 00001111 sequence		—	0.9	—	
$CFO\_BLE\_1M$	Carrier frequency offset		—	25	—	kHz
$FD\_BLE\_1M$	Frequency drift		—	-12	—	kHz
$MaxFD\_BLE\_1M$	Maximum drift rate		—	-1	—	kHz
$InitFD\_BLE\_1M$	Initial frequency drift		—	-9.8	—	kHz
$TXH2\_1M$	Second harmonic of transmit carrier frequency	With Bluetooth Low Energy 1 Mb/s channel at +10 dBm	—	-61.5	—	dBm
		With Bluetooth Low Energy 1 Mb/s channel at +15 dBm	—	-53.7	—	dBm
$TXH3\_1M$	Third harmonic of transmit carrier frequency	With Bluetooth Low Energy 1 Mb/s channel at +10 dBm	—	<-68	—	dBm
		With Bluetooth Low Energy 1 Mb/s channel at +15 dBm	—	<-60	—	dBm

**Table 47. Radio transceiver characteristics: +25 °C ...continued** $V_{DDE} = 2.4\text{ V}$  to  $3.6\text{ V}$ ; unless otherwise specified.

Symbol	Parameter	Conditions	Min	Typ	Max	Unit
PspTX_1M	Transmitter spurious emission, measured conducted into 50 ohms	30 MHz to 1 GHz, peak detector, RBW = 100 kHz	—	-78	—	dBm
		1 GHz to 26 GHz, peak detector, RBW = 1 MHz, based on FCC at +10 dBm	—	-44.8	—	dBm
		1 GHz to 12.75 GHz, peak detector, RBW = 1 MHz, based on ETSI at +10 dBm	—	-41.6	—	dBm
		1 GHz to 26 GHz, average detector, RBW = 1 MHz, based on FCC at +10 dBm	—	-54	—	dBm
		1 GHz to 26 GHz, peak detector, RBW = 1 MHz, based on FCC at +15 dBm	—	-39.4	—	dBm
		1 GHz to 12.75 GHz, peak detector, RBW = 1 MHz, based on ETSI at +15 dBm	—	-40.0	—	dBm
		1 GHz to 26 GHz, average detector, RBW = 1 MHz, based on FCC at +15 dBm	—	-49.4	—	dBm
	Transmitter spurious emission, ETSI exceptions	1.8 GHz to 1.9 GHz	—	-59	—	dBm
		5.15 GHz to 5.3 GHz	—	-57	—	dBm
<b>Receiver Bluetooth Low Energy 2 Mb/s</b>						
S <sub>RX_BLE_2M</sub>	Receiver sensitivity	0.1 % BER	—	-93	—	dBm
NF_BLE_2M	Noise figure	Max gain <a href="#">[1]</a>	—	7	—	dB
P <sub>inMaxRX_BLE_2M</sub>	Maximum receiver input power	0.1 % BER	—	—	10	dBm
C <sub>och_BLE_2M</sub>	Co-channel Interference rejection	0.1 % BER, with wanted channel at -67 dBm <a href="#">[6]</a>	—	-8.5	—	dB
R <sub>ej-2M_BLE_2M</sub>	Interference rejection, 0.1% BER, with wanted channel at -67 dBm <a href="#">[6]</a>	Channel -2 MHz	—	1	—	dB
R <sub>ej+2M_BLE_2M</sub>		Channel +2 MHz	—	10	—	dB
R <sub>ej-4M_BLE_2M</sub>		Channel -4 MHz	—	28.7	—	dB
R <sub>ej+4M_BLE_2M</sub>		Channel +4 MHz	—	47.5	—	dB
R <sub>ej-6M_BLE_2M</sub>		Channel -6 MHz	—	41	—	dB
R <sub>ej+6M_BLE_2M</sub>		Channel +6 MHz	—	51	—	dB
R <sub>ejOOB_BLE_2M</sub>	Out-of-band blocking	From 30 MHz to 2000 MHz, wanted channel Bluetooth Low Energy 1 Mb/s at -67 dBm, 0.1% BER, CW interferer.	—	0	—	dBm
		From 2003 MHz to 2399 MHz and 2484 MHz <a href="#">[3]</a> to 2999 MHz, wanted signal at -67 dBm, 0.1% BER, CW interferer.	—	0	—	dBm
		From 3000 MHz to 12750 MHz, wanted signal at -67 dBm, 0.1% BER, CW interferer.	—	0	—	dBm

**Table 47. Radio transceiver characteristics: +25 °C ...continued** $V_{DDE} = 2.4\text{ V to }3.6\text{ V}$ ; unless otherwise specified.

Symbol	Parameter	Conditions	Min	Typ	Max	Unit
IMP6,12_BLE_2M	Inter-modulation	With CW interferer at $\pm 6\text{ MHz}$ and Bluetooth Low Energy interferer 2 Mb/s at $\pm 12\text{ MHz}$ , wanted channel Bluetooth Low Energy 2 Mb/s at -64 dBm, 0.1% BER [4]	—	-32	—	dBm
IMP8,16_BLE_2M		With CW interferer at $\pm 8\text{ MHz}$ and Bluetooth Low Energy interferer 2 Mb/s at $\pm 16\text{ MHz}$ , wanted channel Bluetooth Low Energy 2 Mb/s at -64 dBm, 0.1% BER [4]	—	-32.5	—	dBm
IMP10,20_BLE_2M		With CW interferer at $\pm 10\text{ MHz}$ and Bluetooth Low Energy interferer 2 Mb/s at $\pm 20\text{ MHz}$ , wanted channel Bluetooth Low Energy 2 Mb/s at -64 dBm, 0.1% BER [4]	—	-30.5	—	dBm
PinBlock_BLE_2M	Blocking input power	Desired channel Bluetooth Low Energy 2 Mb/s, level = measured sensitivity + 6dB. Unwanted channel CW at 2380 MHz, or 2503.5 MHz	—	-22.8	—	dBm
		Desired channel Bluetooth Low Energy 2 Mb/s, level = measured sensitivity + 6dB, channels 0 and 39. Unwanted channel CW at 2300 MHz, 2330 MHz, or 2360 MHz	—	-21.6	—	dBm
		Desired channel Bluetooth Low Energy 2 Mb/s, level = measured sensitivity + 6dB, channels 0 and 39. Unwanted channel CW at 2523.5 MHz, 2553.5 MHz, 2583.5 MHz, 2613.5 MHz, 2643.5 MHz, or 2673.5 MHz	—	-20	—	dBm
RSSIvar_BLE_2M	RSSI variation	Desired channel Bluetooth Low Energy 2 Mbps, over the RSSI range -93 dBm to +5 dBm [5]	—	$\pm 2$	—	dB
PspRX_BLE_2M	Receiver spurious emission, measured conducted into 50 ohms	30 MHz to 1 GHz, 100 kHz RBW, 300 kHz VBW, filter type 3 dB (Gaussian), peak detector, trace mode Max hold	—	-80	—	dBm
		1 GHz to 12.75 GHz, 1 MHz RBW, 3 MHz VBW, filter type 3 dB (Gaussian), peak detector, trace mode Max hold	—	-67	—	dBm
LOLeakRX_BLE_2M	Local oscillator leakage power		—	-98	—	dBm
R <sub>ej</sub> WIFI_BLE_2M	WIFI rejection	0.1% BER, with wanted signal Bluetooth Low Energy 2 Mb/s -67 dBm 2470 MHz, WIFI signal IEEE 802.11n 2447 MHz (20 MHz mode)	—	44	—	dB
<b>Transmitter Bluetooth Low Energy 2 Mb/s</b>						
P <sub>outMax</sub> _BLE_2M	Maximum output power	Measured with CMWxxx equipment	—	14.3	—	dBm
P <sub>out</sub> _BLE_2M	Output power in band tilt	At +10 dBm	—	$\pm 0.2$	—	dB
		At +15 dBm	—	$\pm 0.2$	—	dB
P <sub>outRange</sub> _BLE_2M	Output power control range		—	47.3	—	dB

**Table 47. Radio transceiver characteristics: +25 °C ...continued** $V_{DDE} = 2.4\text{ V}$  to  $3.6\text{ V}$ ; unless otherwise specified.

Symbol	Parameter	Conditions	Min	Typ	Max	Unit
TxAdj2M_BLE_2M	Bluetooth Low Energy adjacent channel transmit Power at 4 MHz offset		—	-46.1	—	dBm
TxAdj3M_BLE_2M	Bluetooth Low Energy adjacent channel transmit Power at $\geq 6$ MHz offset		—	-52.8	—	dBm
$\Delta f_{1\text{avg\_BLE\_2M}}$	Average frequency deviation using a 00001111 sequence		—	499	—	kHz
$\Delta f_{299\_9\_BLE\_2M}$	99.9% of absolute peak frequency deviation using a 10101010 sequence		—	422.3	—	kHz
$\Delta f_{2\text{avg}/\Delta f_{1\text{avg\_BLE\_2M}}}$	Ratio of average frequency deviation using a 10101010 sequence, and average frequency deviation using a 00001111 sequence		—	0.88	—	
CFO_BLE_2M	Carrier frequency offset		—	26.4	—	kHz
FD_BLE_2M	Frequency drift		—	-12.7	—	kHz
MaxFD_BLE_2M	Maximum drift rate		—	-2.1	—	kHz
InitFD_BLE_2M	Initial frequency drift		—	-9.8	—	kHz
TXH2_2M	Second harmonic of transmit carrier frequency	With Bluetooth Low Energy 2 Mb/s channel at +10 dBm	—	-61.0	—	dBm
		With Bluetooth Low Energy 2 Mb/s channel at +15 dBm	—	-53.8	—	dBm
TXH3_2M	Third harmonic of transmit carrier frequency	With Bluetooth Low Energy 2 Mb/s channel at +10 dBm	—	<-68	—	dBm
		With Bluetooth Low Energy 2 Mb/s channel at +15 dBm	—	<-60	—	dBm



**Table 47. Radio transceiver characteristics: +25 °C ...continued**

$V_{DDE} = 2.4\text{ V to }3.6\text{ V}$ ; unless otherwise specified.

Symbol	Parameter	Conditions	Min	Typ	Max	Unit
P <sub>spTX_2M</sub>	Transmitter spurious emission, measured conducted into 50 ohms	30 MHz to 1 GHz, peak detector, RBW = 100 kHz	—	-78	—	dBm
		1 GHz to 26 GHz, peak detector, RBW = 1 MHz, based on FCC at +10 dBm	—	-44	—	dBm
		1 GHz to 12.75 GHz, peak detector, RBW = 1 MHz, based on ETSI at +10 dBm	—	-41.5	—	dBm
		1 GHz to 26 GHz, average detector, RBW = 1 MHz, based on FCC at +10 dBm	—	-59.3	—	dBm
		1 GHz to 26 GHz, peak detector, RBW = 1 MHz, based on FCC at +15 dBm	—	-40.3	—	dBm
		1 GHz to 12.75 GHz, peak detector, RBW = 1 MHz, based on ETSI at +15 dBm	—	-40.2	—	dBm
		1 GHz to 26 GHz, average detector, RBW = 1 MHz, based on FCC at +15 dBm	—	-49.1	—	dBm
	Transmitter spurious emission, ETSI exceptions	1.8 GHz to 1.9 GHz	—	-58.7	—	dBm
		5.15 GHz to 5.3 GHz	—	-56.5	—	dBm

- [1] Considering an integrated BW of 1 MHz, and a minimum SNR of 9 dB for the demodulator.
- [2] Interference rejection 1 Mb/s is the difference between the power of the wanted Bluetooth Low Energy 1 Mb/s at -67 dBm and the power of the modulated interferer Bluetooth Low Energy 1 Mb/s, for 0.1% BER.
- [3] -10 dBm at 2399 MHz
- [4] The intermodulation is the power of one of the two interferers. Both interferers have the same power.
- [5] This RSSI variation over temperature is obtain with the use of the embedded thermometer and the integrated API (see application note).
- [6] Interference rejection 2 Mb/s is the difference between the power of the wanted Bluetooth Low Energy 2 Mb/s at -67 dBm and the power of the modulated interferer Bluetooth Low Energy 2 Mb/s, for 0.1% BER.

**Table 48. Radio transceiver characteristics: -40 °C**

$V_{DDE} = 2.4\text{ V to }3.6\text{ V}$ ; unless otherwise specified.

Symbol	Parameter	Conditions	Min	Typ	Max	Unit
<b>Receiver Bluetooth Low Energy 1 Mb/s</b>						
S <sub>RX_BLE_1M</sub>	Receiver sensitivity	0.1% BER	—	-98	—	dBm
NF_BLE_1M	Noise figure	Max gain <a href="#">[1]</a>	—	6	—	dB
P <sub>inMaxRX_BLE_1M</sub>	Maximum receiver input power	0.1% BER	—	—	10	dBm
C <sub>och_BLE_1M</sub>	Co-channel Interference rejection	0.1% BER, with wanted channel at -67 dBm <a href="#">[2]</a>	—	-7.3	—	dB

**Table 48. Radio transceiver characteristics: -40 °C ...continued** $V_{DDE} = 2.4\text{ V to }3.6\text{ V}$ ; unless otherwise specified.

Symbol	Parameter	Conditions	Min	Typ	Max	Unit
$R_{ej-1M\_BLE\_1M}$	Interference rejection, 0.1% BER, with wanted channel at -67 dBm <sup>[2]</sup>	Channel -1 MHz	—	3.6	—	dB
$R_{ej+1M\_BLE\_1M}$		Channel +1 MHz	—	3.7	—	dB
$R_{ej-2M\_BLE\_1M}$		Channel -2 MHz	—	29.5	—	dB
$R_{ej+2M\_BLE\_1M}$		Channel +2 MHz	—	43	—	dB
$R_{ej-3M\_BLE\_1M}$		Channel $\leq -3$ MHz	—	35.6	—	dB
$R_{ej+3M\_BLE\_1M}$		Channel $\geq +3$ MHz	—	47	—	dB
$R_{ejOOB\_BLE\_1M}$	Out-of-band blocking	From 30 MHz to 2000 MHz, wanted channel Bluetooth Low Energy 1 Mb/s at -67 dBm, 0.1% BER, CW interferer.	—	0	—	dBm
		From 2003 MHz to 2399 MHz and 2484 MHz <sup>[3]</sup> to 2999 MHz, wanted signal at -67 dBm, 0.1% BER, CW interferer.	—	0	—	dBm
		From 3000 MHz to 12750 MHz, wanted signal at -67 dBm, 0.1% BER, CW interferer.	—	0	—	dBm
$IMP3,6\_BLE\_1M$	Inter-modulation	With CW interferer at $\pm 3$ MHz and Bluetooth Low Energy interferer 1 Mb/s at $\pm 6$ MHz, wanted channel Bluetooth Low Energy 1 Mb/s at -64 dBm, 0.1% BER <sup>[5]</sup>	—	-27	—	dBm
$IMP4,8\_BLE\_1M$		With CW interferer at $\pm 4$ MHz and Bluetooth Low Energy interferer 1 Mb/s at $\pm 8$ MHz, wanted channel Bluetooth Low Energy 1 Mb/s at -64 dBm, 0.1% BER <sup>[5]</sup>	—	-27	—	dBm
$IMP5,10\_BLE\_1M$		With CW interferer at $\pm 5$ MHz and Bluetooth Low Energy interferer 1 Mb/s at $\pm 10$ MHz, wanted channel Bluetooth Low Energy 1 Mb/s at -64 dBm, 0.1% BER <sup>[5]</sup>	—	-29	—	dBm
$PinBlock\_BLE\_1M$	Blocking input power	Desired channel Bluetooth Low Energy 1 Mb/s, level = measured sensitivity + 6dB. Unwanted channel CW at 2380 MHz, or 2503.5 MHz	—	-24.5	—	dBm
		Desired channel Bluetooth Low Energy 1 Mb/s, level = measured sensitivity + 6dB, channels 0 and 39. Unwanted channel CW at 2300 MHz, 2330 MHz, or 2360 MHz	—	-23	—	dBm
		Desired channel Bluetooth Low Energy 1 Mb/s, level = measured sensitivity + 6dB, channels 0 and 39. Unwanted channel CW at 2523.5 MHz, 2553.5 MHz, 2583.5 MHz, 2613.5 MHz, 2643.5 MHz, or 2673.5 MHz	—	-21	—	dBm
$RSSIvar\_BLE\_1M$	RSSI variation	Desired channel Bluetooth Low Energy 1 Mbps, over the RSSI range -98 dBm to +5 dBm <sup>[6]</sup>	—	$\pm 2$	—	dB

**Table 48. Radio transceiver characteristics: -40 °C ...continued** $V_{DDE} = 2.4\text{ V}$  to  $3.6\text{ V}$ ; unless otherwise specified.

Symbol	Parameter	Conditions	Min	Typ	Max	Unit
P <sub>spRX_BLE_1M</sub>	Receiver spurious emission, measured conducted into 50 ohms	30 MHz to 1 GHz, 100 kHz RBW, 300 kHz VBW, filter type 3 dB (Gaussian), peak detector, trace mode Max hold	—	-80	—	dBm
		1 GHz to 12.75 GHz, 1 MHz RBW, 3 MHz VBW, filter type 3 dB (Gaussian), peak detector, trace mode Max hold	—	-67	—	dBm
LOLeakR_X_BLE_1M	Local oscillator leakage power		—	-98	—	dBm
R <sub>ejWIFI_BLE_1M</sub>	WIFI rejection	0.1% BER, with wanted signal Bluetooth Low Energy 1 Mb/s -67 dBm 2470 MHz, WIFI signal IEEE 802.11n 2447 MHz (20 MHz mode)	—	41	—	dB
<b>Transmitter Bluetooth Low Energy 1 Mb/s</b>						
P <sub>outMax_BLE_1M</sub>	Maximum output power	Measured with CMWxxx equipment	—	14.8	—	dBm
P <sub>out_BLE_1M</sub>	Output power in band tilt	At +10 dBm	—	±0.2	—	dB
		At +15 dBm	—	±0.2	—	dB
P <sub>outRange_BLE_1M</sub>	Output power control range		—	47	—	dB
TxA <sub>adj2M_BLE_1M</sub>	Bluetooth Low Energy adjacent channel transmit Power at 2 MHz offset		—	-43.5	—	dBm
TxA <sub>adj3M_BLE_1M</sub>	Bluetooth Low Energy adjacent channel transmit Power at ≥ 3 MHz offset		—	-46.7	—	dBm
Δf <sub>1avg_BLE_1M</sub>	Average frequency deviation using a 00001111 sequence		—	248.7	—	kHz
Δf <sub>299_9_BLE_1M</sub>	99.9% of absolute peak frequency deviation using a 10101010 sequence		—	208.6	—	kHz
Δf <sub>2avg/Δf1avg_BLE_1M</sub>	Ratio of average frequency deviation using a 10101010 sequence, and average frequency deviation using a 00001111 sequence		—	0.90	—	
CFO_BLE_1M	Carrier frequency offset		—	55.3	—	kHz
FD_BLE_1M	Frequency drift		—	-10.4	—	kHz
MaxFD_BLE_1M	Maximum drift rate		—	0.1	—	kHz

**Table 48. Radio transceiver characteristics: -40 °C ...continued** $V_{DDE} = 2.4\text{ V to }3.6\text{ V}$ ; unless otherwise specified.

Symbol	Parameter	Conditions	Min	Typ	Max	Unit
InitFD_BLE_1M	Initial frequency drift		—	-9.3	—	kHz
TXH2_1M	Second harmonic of transmit carrier frequency	With Bluetooth Low Energy 1 Mb/s channel at +10 dBm	—	-60.9	—	dBm
		With Bluetooth Low Energy 1 Mb/s channel at +15 dBm	—	-55.1	—	dBm
TXH3_1M	Third harmonic of transmit carrier frequency	With Bluetooth Low Energy 1 Mb/s channel at +10 dBm	—	<-68	—	dBm
		With Bluetooth Low Energy 1 Mb/s channel at +15 dBm	—	<-60.4	—	dBm
PspTX_1M	Transmitter spurious emission, measured conducted into 50 ohms	30 MHz to 1 GHz, peak detector, RBW = 100 kHz	—	-78	—	dBm
		1 GHz to 26 GHz, peak detector, RBW = 1 MHz, based on FCC at +10 dBm	—	-43.6	—	dBm
		1 GHz to 12.75 GHz, peak detector, RBW = 1 MHz, based on ETSI at +10 dBm	—	-40	—	dBm
		1 GHz to 26 GHz, average detector, RBW = 1 MHz, based on FCC at +10 dBm	—	-53.5	—	dBm
		1 GHz to 26 GHz, peak detector, RBW = 1 MHz, based on FCC at +15 dBm	—	-38.5	—	dBm
		1 GHz to 12.75 GHz, peak detector, RBW = 1 MHz, based on ETSI at +15 dBm	—	-48.2	—	dBm
		1 GHz to 26 GHz, average detector, RBW = 1 MHz, based on FCC at +15 dBm	—	-49.2	—	dBm
	Transmitter spurious emission, ETSI exceptions	1.8 GHz to 1.9 GHz	—	-58.2	—	dBm
	5.15 GHz to 5.3 GHz	—	-56.9	—	dBm	
<b>Receiver Bluetooth Low Energy 2 Mb/s</b>						
S <sub>RX_BLE_2M</sub>	Receiver sensitivity	0.1 % BER	—	-95	—	dBm
NF_BLE_2M	Noise figure	Max gain <a href="#">[1]</a>	—	7	—	dB
P <sub>inMaxRX_BLE_2M</sub>	Maximum receiver input power	0.1 % BER	—	—	10	dBm
CO <sub>ch_BLE_2M</sub>	Co-channel Interference rejection	0.1 % BER, with wanted channel at -67 dBm <a href="#">[4]</a>	—	-8.6	—	dB

**Table 48. Radio transceiver characteristics: -40 °C ...continued** $V_{DDE} = 2.4\text{ V to }3.6\text{ V}$ ; unless otherwise specified.

Symbol	Parameter	Conditions	Min	Typ	Max	Unit
$R_{ej-2M\_BLE\_2M}$	Interference rejection, 0.1% BER, with wanted channel at -67 dBm <sup>[4]</sup>	Channel -2 MHz	—	1.7	—	dB
$R_{ej+2M\_BLE\_2M}$		Channel +2 MHz	—	9.8	—	dB
$R_{ej-4M\_BLE\_2M}$		Channel -4 MHz	—	28.6	—	dB
$R_{ej+4M\_BLE\_2M}$		Channel +4 MHz	—	47.8	—	dB
$R_{ej-6M\_BLE\_2M}$		Channel -6 MHz	—	41.2	—	dB
$R_{ej+6M\_BLE\_2M}$		Channel +6 MHz	—	53.3	—	dB
$R_{ejOOB\_BLE\_2M}$	Out-of-band blocking	From 30 MHz to 2000 MHz, wanted channel Bluetooth Low Energy 1 Mb/s at -67 dBm, 0.1% BER, CW interferer.	—	0	—	dBm
		From 2003 MHz to 2399 MHz and 2484 MHz <sup>[3]</sup> to 2999 MHz, wanted signal at -67 dBm, 0.1% BER, CW interferer.	—	0	—	dBm
		From 3000 MHz to 12750 MHz, wanted signal at -67 dBm, 0.1% BER, CW interferer.	—	0	—	dBm
$IMP6,12\_BLE\_2M$	Inter-modulation	With CW interferer at $\pm 6$ MHz and Bluetooth <sup>[5]</sup> Low Energy interferer 2 Mb/s at $\pm 12$ MHz, wanted channel Bluetooth Low Energy 2 Mb/s at -64 dBm, 0.1% BER	—	-32	—	dBm
$IMP8,16\_BLE\_2M$		With CW interferer at $\pm 8$ MHz and Bluetooth <sup>[5]</sup> Low Energy interferer 2 Mb/s at $\pm 16$ MHz, wanted channel Bluetooth Low Energy 2 Mb/s at -64 dBm, 0.1% BER	—	-33.5	—	dBm
$IMP10,20\_BLE\_2M$		With CW interferer at $\pm 10$ MHz and Bluetooth <sup>[5]</sup> Low Energy interferer 2 Mb/s at $\pm 20$ MHz, wanted channel Bluetooth Low Energy 2 Mb/s at -64 dBm, 0.1% BER	—	-32	—	dBm
$PinBlock\_BLE\_2M$	Blocking input power	Desired channel Bluetooth Low Energy 2 Mb/s, level = measured sensitivity + 6dB. Unwanted channel CW at 2380 MHz, or 2503.5 MHz	—	-24.8	—	dBm
		Desired channel Bluetooth Low Energy 2 Mb/s, level = measured sensitivity + 6dB, channels 0 and 39. Unwanted channel CW at 2300 MHz, 2330 MHz, or 2360 MHz	—	-23	—	dBm
		Desired channel Bluetooth Low Energy 2 Mb/s, level = measured sensitivity + 6dB, channels 0 and 39. Unwanted channel CW at 2523.5 MHz, 2553.5 MHz, 2583.5 MHz, 2613.5 MHz, 2643.5 MHz, or 2673.5 MHz	—	-21.6	—	dBm
$RSSIvar\_BLE\_2M$	RSSI variation	Desired channel Bluetooth Low Energy 2 <sup>[6]</sup> Mbps, over the RSSI range -94.5 dBm to +5 dBm	—	$\pm 2$	—	dB

**Table 48. Radio transceiver characteristics: -40 °C ...continued** $V_{DDE} = 2.4\text{ V to }3.6\text{ V}$ ; unless otherwise specified.

Symbol	Parameter	Conditions	Min	Typ	Max	Unit
P <sub>spRX_BLE_2M</sub>	Receiver spurious emission, measured conducted into 50 ohms	30 MHz to 1 GHz, 100 kHz RBW, 300 kHz VBW, filter type 3 dB (Gaussian), peak detector, trace mode Max hold	—	-80	—	dBm
		1 GHz to 12.75 GHz, 1 MHz RBW, 3 MHz VBW, filter type 3 dB (Gaussian), peak detector, trace mode Max hold	—	-67	—	dBm
LOLeakR_X_BLE_2M	Local oscillator leakage power		—	-98	—	dBm
R <sub>ejWIFI_BLE_2M</sub>	WIFI rejection	0.1% BER, with wanted signal Bluetooth Low Energy 2 Mb/s -67 dBm 2470 MHz, WIFI signal IEEE 802.11n 2447 MHz (20 MHz mode)	—	44	—	dB
<b>Transmitter Bluetooth Low Energy 2 Mb/s</b>						
P <sub>outMax_BLE_2M</sub>	Maximum output power	Measured with CMWxxx equipment	—	14.8	—	dBm
P <sub>out_BLE_2M</sub>	Output power in band tilt	At +10 dBm	—	±0.2	—	dB
		At +15 dBm	—	±0.2	—	dB
P <sub>outRange_BLE_2M</sub>	Output power control range		—	47.3	—	dB
TxAdj2M_BLE_2M	Bluetooth Low Energy adjacent channel transmit Power at 4 MHz offset		—	-45.9	—	dBm
TxAdj3M_BLE_2M	Bluetooth Low Energy adjacent channel transmit Power at ≥ 6 MHz offset		—	-52.8	—	dBm
Δf1avg_BLE_2M	Average frequency deviation using a 00001111 sequence		—	503.2	—	kHz
Δf299_9_BLE_2M	99.9% of absolute peak frequency deviation using a 10101010 sequence		—	426.7	—	kHz
Δf2avg/Δf1avg_BLE_2M	Ratio of average frequency deviation using a 10101010 sequence, and average frequency deviation using a 00001111 sequence		—	0.88	—	
CFO_BLE_2M	Carrier frequency offset		—	56	—	kHz
FD_BLE_2M	Frequency drift		—	-11	—	kHz
MaxFD_BLE_2M	Maximum drift rate		—	-0.1	—	kHz

**Table 48. Radio transceiver characteristics: -40 °C ...continued** $V_{DDE} = 2.4\text{ V to }3.6\text{ V}$ ; unless otherwise specified.

Symbol	Parameter	Conditions	Min	Typ	Max	Unit
InitFD_BLE_2M	Initial frequency drift		—	-9.4	—	kHz
TXH2_2M	Second harmonic of transmit carrier frequency	With Bluetooth Low Energy 2 Mb/s channel at +10 dBm	—	-61	—	dBm
		With Bluetooth Low Energy 2 Mb/s channel at +15 dBm	—	-55	—	dBm
TXH3_2M	Third harmonic of transmit carrier frequency	With Bluetooth Low Energy 2 Mb/s channel at +10 dBm	—	<-68	—	dBm
		With Bluetooth Low Energy 2 Mb/s channel at +15 dBm	—	<-60	—	dBm
PspTX_2M	Transmitter spurious emission, measured conducted into 50 ohms	30 MHz to 1 GHz, peak detector, RBW = 100 kHz	—	-78	—	dBm
		1 GHz to 26 GHz, peak detector, RBW = 1 MHz, based on FCC at +10 dBm	—	-45	—	dBm
		1 GHz to 12.75 GHz, peak detector, RBW = 1 MHz, based on ETSI at +10 dBm	—	-40	—	dBm
		1 GHz to 26 GHz, average detector, RBW = 1 MHz, based on FCC at +10 dBm	—	-53.6	—	dBm
		1 GHz to 26 GHz, peak detector, RBW = 1 MHz, based on FCC at +15 dBm	—	-39.6	—	dBm
		1 GHz to 12.75 GHz, peak detector, RBW = 1 MHz, based on ETSI at +15 dBm	—	-38.5	—	dBm
		1 GHz to 26 GHz, average detector, RBW = 1 MHz, based on FCC at +15 dBm	—	-49.4	—	dBm
		Transmitter spurious emission, ETSI exceptions	1.8 GHz to 1.9 GHz	—	-58.1	—
5.15 GHz to 5.3 GHz	—	-56.9	—	dBm		

- [1] Considering an integrated BW of 1 MHz, and a minimum SNR of 9 dB for the demodulator.
- [2] Interference rejection 1 Mb/s is the difference between the power of the wanted Bluetooth Low Energy 1 Mb/s at -67 dBm and the power of the modulated interferer Bluetooth Low Energy 1 Mb/s, for 0.1% BER.
- [3] -10 dBm at 2399 MHz
- [4] Interference rejection 2 Mb/s is the difference between the power of the wanted Bluetooth Low Energy 2 Mb/s at -67 dBm and the power of the modulated interferer Bluetooth Low Energy 2 Mb/s, for 0.1% BER.
- [5] The intermodulation is the power of one of the two interferers. Both interferers have the same power.
- [6] This RSSI variation over temperature is obtain with the use of the embedded thermometer and the integrated API (see application note).

**Table 49. Radio transceiver characteristics: +85 °C** $V_{DDE} = 2.4\text{ V to }3.6\text{ V}$ ; unless otherwise specified.

Symbol	Parameter	Conditions	Min	Typ	Max	Unit
<b>Receiver Bluetooth Low Energy 1 Mb/s</b>						
S <sub>RX_BLE_1M</sub>	Receiver sensitivity	0.1% BER	—	-94	—	dBm
NF_BLE_1M	Noise figure	Max gain <a href="#">[1]</a>	—	10	—	dB

**Table 49. Radio transceiver characteristics: +85 °C ...continued**

$V_{DDE} = 2.4\text{ V to }3.6\text{ V}$ ; unless otherwise specified.

Symbol	Parameter	Conditions	Min	Typ	Max	Unit
$P_{inMaxRX\_BLE\_1M}$	Maximum receiver input power	0.1% BER	—	—	10	dBm
$C_{och\_BLE\_1M}$	Co-channel Interference rejection	0.1% BER, with wanted channel at -67 dBm [2]	—	-7.5	—	dB
$R_{ej-1M\_BLE\_1M}$	Interference rejection, 0.1% BER, with wanted channel at -67 dBm[2]	Channel -1 MHz	—	3.6	—	dB
$R_{ej+1M\_BLE\_1M}$		Channel +1 MHz	—	4.6	—	dB
$R_{ej-2M\_BLE\_1M}$		Channel -2 MHz	—	29.6	—	dB
$R_{ej+2M\_BLE\_1M}$		Channel +2 MHz	—	44	—	dB
$R_{ej-3M\_BLE\_1M}$		Channel $\leq -3$ MHz	—	36.7	—	dB
$R_{ej+3M\_BLE\_1M}$		Channel $\geq +3$ MHz	—	49	—	dB
$R_{ejOOB\_BLE\_1M}$	Out-of-band blocking	From 30 MHz to 2000 MHz, wanted channel Bluetooth Low Energy 1 Mb/s at -67 dBm, 0.1% BER, CW interferer.	—	0	—	dBm
		From 2003 MHz to 2399 MHz and 2484 MHz [3] to 2999 MHz, wanted signal at -67 dBm, 0.1% BER, CW interferer.	—	0	—	dBm
		From 3000 MHz to 12750 MHz, wanted signal at -67 dBm, 0.1% BER, CW interferer.	—	0	—	dBm
$IMP3,6\_BLE\_1M$	Inter-modulation	With CW interferer at $\pm 3$ MHz and Bluetooth Low Energy interferer 1 Mb/s at $\pm 6$ MHz, wanted channel Bluetooth Low Energy 1 Mb/s at -64 dBm, 0.1% BER	—	-29	—	dBm
$IMP4,8\_BLE\_1M$		With CW interferer at $\pm 4$ MHz and Bluetooth Low Energy interferer 1 Mb/s at $\pm 8$ MHz, wanted channel Bluetooth Low Energy 1 Mb/s at -64 dBm, 0.1% BER	—	-31	—	dBm
$IMP5,10\_BLE\_1M$		With CW interferer at $\pm 5$ MHz and Bluetooth Low Energy interferer 1 Mb/s at $\pm 10$ MHz, wanted channel Bluetooth Low Energy 1 Mb/s at -64 dBm, 0.1% BER	—	-32	—	dBm
$PinBlock\_BLE\_1M$	Blocking input power	Desired channel Bluetooth Low Energy 1 Mb/s, level = measured sensitivity + 6dB. Unwanted channel CW at 2380 MHz, or 2503.5 MHz	—	-21	—	dBm
		Desired channel Bluetooth Low Energy 1 Mb/s, level = measured sensitivity + 6dB, channels 0 and 39. Unwanted channel CW at 2300 MHz, 2330 MHz, or 2360 MHz	—	-19	—	dBm
		Desired channel Bluetooth Low Energy 1 Mb/s, level = measured sensitivity + 6dB, channels 0 and 39. Unwanted channel CW at 2523.5 MHz, 2553.5 MHz, 2583.5 MHz, 2613.5 MHz, 2643.5 MHz, or 2673.5 MHz	—	-17.5	—	dBm



**Table 49. Radio transceiver characteristics: +85 °C ...continued** $V_{DDE} = 2.4\text{ V to }3.6\text{ V}$ ; unless otherwise specified.

Symbol	Parameter	Conditions	Min	Typ	Max	Unit
RSSIvar_BLE_1M	RSSI variation	Desired channel Bluetooth Low Energy 1 Mbps, over the RSSI range -94 dBm to +5 dBm [6]	—	±2	—	dB
PspRX_BLE_1M	Receiver spurious emission, measured conducted into 50 ohms	30 MHz to 1 GHz, 100 kHz RBW, 300 kHz VBW, filter type 3 dB (Gaussian), peak detector, trace mode Max hold	—	-80	—	dBm
		1 GHz to 12.75 GHz, 1 MHz RBW, 3 MHz VBW, filter type 3 dB (Gaussian), peak detector, trace mode Max hold	—	-67	—	dBm
LOLeakRX_BLE_1M	Local oscillator leakage power		—	-98	—	dBm
R <sub>ej</sub> WIFI_BLE_1M	WIFI rejection	0.1% BER, with wanted signal Bluetooth Low Energy 1 Mb/s -67 dBm 2470 MHz, WIFI signal IEEE 802.11n 2447 MHz (20MHz mode)	—	44	—	dB
<b>Transmitter Bluetooth Low Energy 1 Mb/s</b>						
P <sub>outMax</sub> _BLE_1M	Maximum output power	Measured with CMWxxx equipment	—	13.9	—	dBm
P <sub>out</sub> _BLE_1M	Output power in band tilt	At +10 dBm	—	±0.2	—	dB
		At +15 dBm	—	±0.2	—	dB
P <sub>outRange</sub> _BLE_1M	Output power control range		—	47.4	—	dB
TxAdj2M_BLE_1M	Bluetooth Low Energy adjacent channel transmit Power at 2 MHz offset		—	-43.4	—	dBm
TxAdj3M_BLE_1M	Bluetooth Low Energy adjacent channel transmit Power at ≥ 3 MHz offset		—	-46.3	—	dBm
Δf1avg_BLE_1M	Average frequency deviation using a 00001111 sequence		—	249.2	—	kHz
Δf299_9_BLE_1M	99.9% of absolute peak frequency deviation using a 10101010 sequence		—	205.0	—	kHz
Δf2avg/Δf1avg_BLE_1M	Ratio of average frequency deviation using a 10101010 sequence, and average frequency deviation using a 00001111 sequence		—	0.9	—	
CFO_BLE_1M	Carrier frequency offset		—	-50.4	—	kHz
FD_BLE_1M	Frequency drift		—	-15.2	—	kHz

**Table 49. Radio transceiver characteristics: +85 °C ...continued** $V_{DDE} = 2.4\text{ V}$  to  $3.6\text{ V}$ ; unless otherwise specified.

Symbol	Parameter	Conditions	Min	Typ	Max	Unit
MaxFD_BLE_1M	Maximum drift rate		—	0	—	kHz
InitFD_BLE_1M	Initial frequency drift		—	-13.4	—	kHz
TXH2_1M	Second harmonic of transmit carrier frequency	With Bluetooth Low Energy 1 Mb/s channel at +10 dBm	—	-62.2	—	dBm
		With Bluetooth Low Energy 1 Mb/s channel at +15 dBm	—	-54.8	—	dBm
TXH3_1M	Third harmonic of transmit carrier frequency	With Bluetooth Low Energy 1 Mb/s channel at +10 dBm	—	<-68	—	dBm
		With Bluetooth Low Energy 1 Mb/s channel at +15 dBm	—	<-60.9	—	dBm
PspTX_1M	Transmitter spurious emission, measured conducted into 50 ohms	30 MHz to 1 GHz, peak detector, RBW = 100 kHz	—	-78	—	dBm
		1 GHz to 26 GHz, peak detector, RBW = 1 MHz, based on FCC at +10 dBm	—	-44.7	—	dBm
		1 GHz to 12.75 GHz, peak detector, RBW = 1 MHz, based on ETSI at +10 dBm	—	-43.8	—	dBm
		1 GHz to 26 GHz, average detector, RBW = 1 MHz, based on FCC at +10 dBm	—	-55	—	dBm
		1 GHz to 26 GHz, peak detector, RBW = 1 MHz, based on FCC at +15 dBm	—	-39.1	—	dBm
		1 GHz to 12.75 GHz, peak detector, RBW = 1 MHz, based on ETSI at +15 dBm	—	-42.2	—	dBm
		1 GHz to 26 GHz, average detector, RBW = 1 MHz, based on FCC at +15 dBm	—	-49.9	—	dBm
	Transmitter spurious emission, ETSI exceptions	1.8 GHz to 1.9 GHz	—	-57.9	—	dBm
	5.15 GHz to 5.3 GHz	—	-56.6	—	dBm	
<b>Receiver Bluetooth Low Energy 2 Mb/s</b>						
S <sub>RX_BLE_2M</sub>	Receiver sensitivity	0.1 % BER	—	-90	—	dBm
NF_BLE_2M	Noise figure	Max gain <a href="#">[1]</a>	—	7	—	dB
P <sub>inMaxRX_BLE_2M</sub>	Maximum receiver input power	0.1 % BER	—	—	10	dBm
C <sub>och_BLE_2M</sub>	Co-channel Interference rejection	0.1 % BER, with wanted channel at -67 dBm <a href="#">[4]</a>	—	-8.6	—	dB

**Table 49. Radio transceiver characteristics: +85 °C ...continued** $V_{DDE} = 2.4\text{ V to }3.6\text{ V}$ ; unless otherwise specified.

Symbol	Parameter	Conditions	Min	Typ	Max	Unit
$R_{ej-2M\_BLE\_2M}$	Interference rejection, 0.1% BER, with wanted channel at -67 dBm <sup>[4]</sup>	Channel -2 MHz	—	1	—	dB
$R_{ej+2M\_BLE\_2M}$		Channel +2 MHz	—	11.3	—	dB
$R_{ej-4M\_BLE\_2M}$		Channel -4 MHz	—	29	—	dB
$R_{ej+4M\_BLE\_2M}$		Channel +4 MHz	—	48.8	—	dB
$R_{ej-6M\_BLE\_2M}$		Channel -6 MHz	—	42	—	dB
$R_{ej+6M\_BLE\_2M}$		Channel +6 MHz	—	54	—	dB
$R_{ejOOB\_BLE\_2M}$	Out-of-band blocking	From 30 MHz to 2000 MHz, wanted channel Bluetooth Low Energy 1 Mb/s at -67 dBm, 0.1% BER, CW interferer.	—	0	—	dBm
		From 2003 MHz to 2399 MHz and 2484 MHz <sup>[3]</sup> to 2999 MHz, wanted signal at -67 dBm, 0.1% BER, CW interferer.	—	0	—	dBm
		From 3000 MHz to 12750 MHz, wanted signal at -67 dBm, 0.1% BER, CW interferer.	—	0	—	dBm
$IMP6,12\_BLE\_2M$	Inter-modulation	With CW interferer at $\pm 6$ MHz and Bluetooth Low Energy interferer 2 Mb/s at $\pm 12$ MHz, wanted channel Bluetooth Low Energy 2 Mb/s at -64 dBm, 0.1% BER <sup>[5]</sup>	—	-32	—	dBm
$IMP8,16\_BLE\_2M$		With CW interferer at $\pm 8$ MHz and Bluetooth Low Energy interferer 2 Mb/s at $\pm 16$ MHz, wanted channel Bluetooth Low Energy 2 Mb/s at -64 dBm, 0.1% BER <sup>[5]</sup>	—	-31.3	—	dBm
$IMP10,20\_BLE\_2M$		With CW interferer at $\pm 10$ MHz and Bluetooth Low Energy interferer 2 Mb/s at $\pm 20$ MHz, wanted channel Bluetooth Low Energy 2 Mb/s at -64 dBm, 0.1% BER <sup>[5]</sup>	—	-30.6	—	dBm
$PinBlock\_BLE\_2M$	Blocking input power	Desired channel Bluetooth Low Energy 2 Mb/s, level = measured sensitivity + 6dB. Unwanted channel CW at 2380 MHz, or 2503.5 MHz	—	-22.6	—	dBm
		Desired channel Bluetooth Low Energy 2 Mb/s, level = measured sensitivity + 6dB, channels 0 and 39. Unwanted channel CW at 2300 MHz, 2330 MHz, or 2360 MHz	—	-19.7	—	dBm
		Desired channel Bluetooth Low Energy 2 Mb/s, level = measured sensitivity + 6dB, channels 0 and 39. Unwanted channel CW at 2523.5 MHz, 2553.5 MHz, 2583.5 MHz, 2613.5 MHz, 2643.5 MHz, or 2673.5 MHz	—	-18.3	—	dBm
$RSSIvar\_BLE\_2M$	RSSI variation	Desired channel Bluetooth Low Energy 2 Mbps, over the RSSI range -90 dBm to +5 dBm <sup>[6]</sup>	—	$\pm 2$	—	dB

**Table 49. Radio transceiver characteristics: +85 °C ...continued** $V_{DDE} = 2.4\text{ V to }3.6\text{ V}$ ; unless otherwise specified.

Symbol	Parameter	Conditions	Min	Typ	Max	Unit
P <sub>spRX_BLE_2M</sub>	Receiver spurious emission, measured conducted into 50 ohms	30 MHz to 1 GHz, 100 kHz RBW, 300 kHz VBW, filter type 3 dB (Gaussian), peak detector, trace mode Max hold	—	-80	—	dBm
		1 GHz to 12.75 GHz, 1 MHz RBW, 3 MHz VBW, filter type 3 dB (Gaussian), peak detector, trace mode Max hold	—	-67	—	dBm
LOLeakRX_BLE_2M	Local oscillator leakage power		—	-98	—	dBm
R <sub>ejWIFI_BLE_2M</sub>	WIFI rejection	0.1% BER, with wanted signal Bluetooth Low Energy 2 Mb/s -67 dBm 2470 MHz, WIFI signal IEEE 802.11n 2447 MHz (20 MHz mode)	—	43	—	dB
<b>Transmitter Bluetooth Low Energy 2 Mb/s</b>						
P <sub>outMax_BLE_2M</sub>	Maximum output power	Measured with CMWxxx equipment	—	13.9	—	dBm
P <sub>out_BLE_2M</sub>	Output power in band tilt	At +10 dBm	—	±0.2	—	dB
		At +15 dBm	—	±0.2	—	dB
P <sub>outRange_BLE_2M</sub>	Output power control range		—	47.4	—	dB
TxAdj2M_BLE_2M	Bluetooth Low Energy adjacent channel transmit Power at 4 MHz offset		—	-46.2	—	dBm
TxAdj3M_BLE_2M	Bluetooth Low Energy adjacent channel transmit Power at ≥ 6 MHz offset		—	-52.5	—	dBm
Δf1avg_BLE_2M	Average frequency deviation using a 00001111 sequence		—	503.8	—	kHz
Δf299_9_BLE_2M	99.9% of absolute peak frequency deviation using a 10101010 sequence		—	420.3	—	kHz
Δf2avg/Δf1avg_BLE_2M	Ratio of average frequency deviation using a 10101010 sequence, and average frequency deviation using a 00001111 sequence		—	0.88	—	
CFO_BLE_2M	Carrier frequency offset		—	-50	—	kHz
FD_BLE_2M	Frequency drift		—	-17.3	—	kHz
MaxFD_BLE_2M	Maximum drift rate		—	-0.9	—	kHz

**Table 49. Radio transceiver characteristics: +85 °C ...continued** $V_{DDE} = 2.4\text{ V to }3.6\text{ V}$ ; unless otherwise specified.

Symbol	Parameter	Conditions	Min	Typ	Max	Unit
InitFD_BLE_2M	Initial frequency drift		—	-15.1	—	kHz
TXH2_2M	Second harmonic of transmit carrier frequency	With Bluetooth Low Energy 2 Mb/s channel at +10 dBm	—	-62.1	—	dBm
		With Bluetooth Low Energy 2 Mb/s channel at +15 dBm	—	-54.8	—	dBm
TXH3_2M	Third harmonic of transmit carrier frequency	With Bluetooth Low Energy 2 Mb/s channel at +10 dBm	—	<-68	—	dBm
		With Bluetooth Low Energy 2 Mb/s channel at +15 dBm	—	<-60.9	—	dBm
PspTX_2M	Transmitter spurious emission, measured conducted into 50 ohms	30 MHz to 1 GHz, peak detector, RBW = 100 kHz	—	-78	—	dBm
		1 GHz to 26 GHz, peak detector, RBW = 1 MHz, based on FCC at +10 dBm	—	-45.5	—	dBm
		1 GHz to 12.75 GHz, peak detector, RBW = 1 MHz, based on ETSI at +10 dBm	—	-43.7	—	dBm
		1 GHz to 26 GHz, average detector, RBW = 1 MHz, based on FCC at +10 dBm	—	-55	—	dBm
		1 GHz to 26 GHz, peak detector, RBW = 1 MHz, based on FCC at +15 dBm	—	-40.3	—	dBm
		1 GHz to 12.75 GHz, peak detector, RBW = 1 MHz, based on ETSI at +15 dBm	—	-41.8	—	dBm
		1 GHz to 26 GHz, average detector, RBW = 1 MHz, based on FCC at +15 dBm	—	-49.9	—	dBm
	Transmitter spurious emission, ETSI exceptions	1.8 GHz to 1.9 GHz	—	-57.9	—	dBm
5.15 GHz to 5.3 GHz		—	-57.0	—	dBm	

- [1] Considering an integrated BW of 1 MHz, and a minimum SNR of 9 dB for the demodulator.
- [2] Interference rejection 1 Mb/s is the difference between the power of the wanted Bluetooth Low Energy 1 Mb/s at -67 dBm and the power of the modulated interferer Bluetooth Low Energy 1 Mb/s, for 0.1% BER.
- [3] -10 dBm at 2399 MHz.
- [4] Interference rejection 2 Mb/s is the difference between the power of the wanted Bluetooth Low Energy 2 Mb/s at -67 dBm and the power of the modulated interferer Bluetooth Low Energy 2 Mb/s, for 0.1% BER.
- [5] The intermodulation is the power of one of the two interferers. Both interferers have the same power.
- [6] This RSSI variation over temperature is obtain with the use of the embedded thermometer and the integrated API (see application note).

# 15. Package outline

**HVQFN40: plastic thermal enhanced very thin quad flat package; no leads;**  
**40 terminals; body 6 x 6 x 0.85 mm**

**SOT618-1**

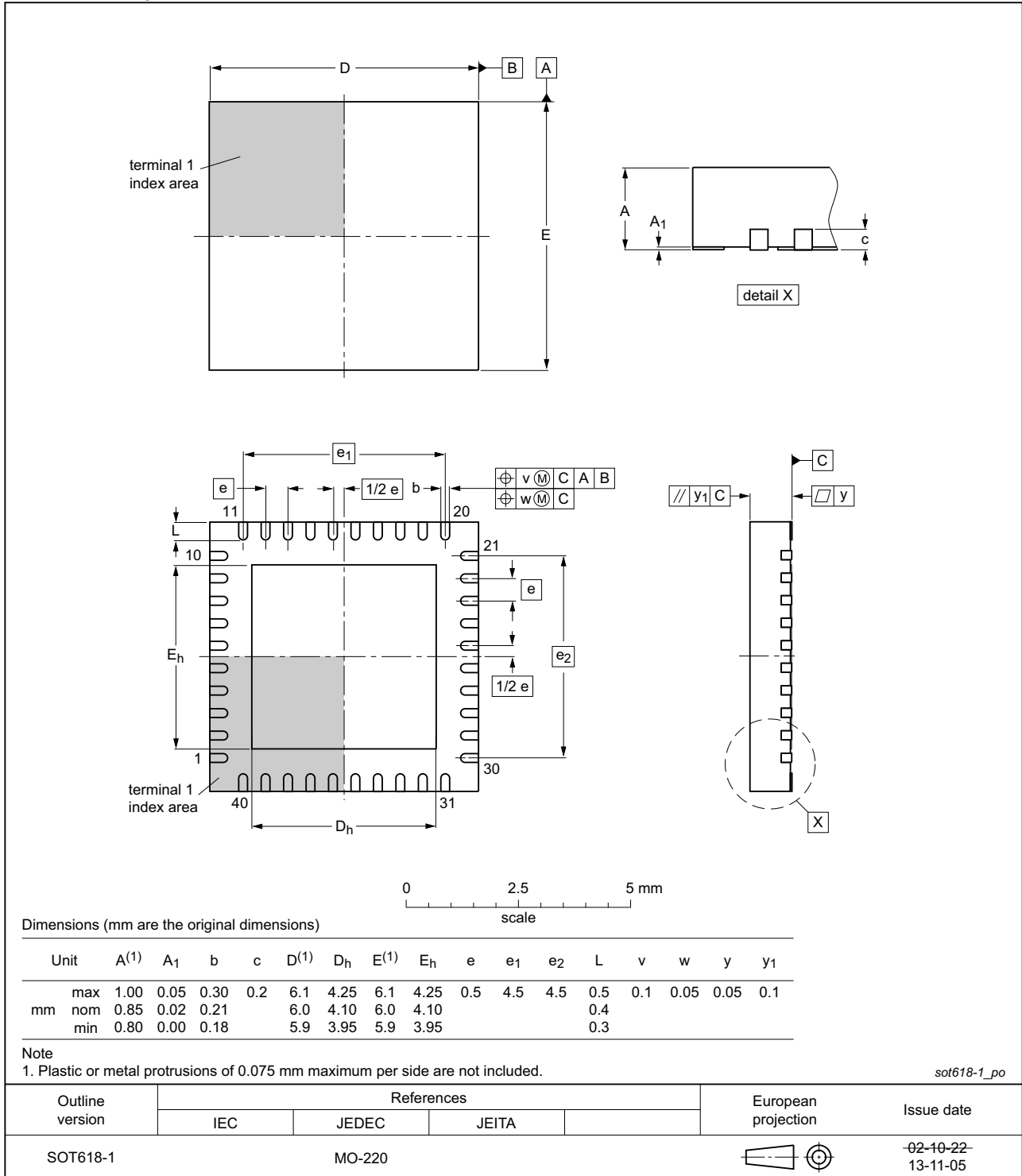

**Fig 23. Package outline SOT618-1 HVQFN40**

## 16. Soldering of SMD packages

This text provides a very brief insight into a complex technology. A more in-depth account of soldering ICs can be found in Application Note *AN10365 "Surface mount reflow soldering description"*.

### 16.1 Introduction to soldering

Soldering is one of the most common methods through which packages are attached to Printed Circuit Boards (PCBs), to form electrical circuits. The soldered joint provides both the mechanical and the electrical connection. There is no single soldering method that is ideal for all IC packages. Wave soldering is often preferred when through-hole and Surface Mount Devices (SMDs) are mixed on one printed wiring board; however, it is not suitable for fine pitch SMDs. Reflow soldering is ideal for the small pitches and high densities that come with increased miniaturization.

### 16.2 Wave and reflow soldering

Wave soldering is a joining technology in which the joints are made by solder coming from a standing wave of liquid solder. The wave soldering process is suitable for the following:

- Through-hole components
- Leaded or leadless SMDs, which are glued to the surface of the printed circuit board

Not all SMDs can be wave soldered. Packages with solder balls, and some leadless packages which have solder lands underneath the body, cannot be wave soldered. Also, leaded SMDs with leads having a pitch smaller than ~0.6 mm cannot be wave soldered, due to an increased probability of bridging.

The reflow soldering process involves applying solder paste to a board, followed by component placement and exposure to a temperature profile. Leaded packages, packages with solder balls, and leadless packages are all reflow solderable.

Key characteristics in both wave and reflow soldering are:

- Board specifications, including the board finish, solder masks and vias
- Package footprints, including solder thieves and orientation
- The moisture sensitivity level of the packages
- Package placement
- Inspection and repair
- Lead-free soldering versus SnPb soldering

### 16.3 Wave soldering

Key characteristics in wave soldering are:

- Process issues, such as application of adhesive and flux, clinching of leads, board transport, the solder wave parameters, and the time during which components are exposed to the wave
- Solder bath specifications, including temperature and impurities

## 16.4 Reflow soldering

Key characteristics in reflow soldering are:

- Lead-free versus SnPb soldering; note that a lead-free reflow process usually leads to higher minimum peak temperatures (see [Figure 23](#)) than a SnPb process, thus reducing the process window
- Solder paste printing issues including smearing, release, and adjusting the process window for a mix of large and small components on one board
- Reflow temperature profile; this profile includes preheat, reflow (in which the board is heated to the peak temperature) and cooling down. It is imperative that the peak temperature is high enough for the solder to make reliable solder joints (a solder paste characteristic). In addition, the peak temperature must be low enough that the packages and/or boards are not damaged. The peak temperature of the package depends on package thickness and volume and is classified in accordance with [Table 50](#) and [51](#)

**Table 50. SnPb eutectic process (from J-STD-020D)**

Package thickness (mm)	Package reflow temperature (°C)	
	Volume (mm <sup>3</sup> )	
	< 350	≥ 350
< 2.5	235	220
≥ 2.5	220	220

**Table 51. Lead-free process (from J-STD-020D)**

Package thickness (mm)	Package reflow temperature (°C)		
	Volume (mm <sup>3</sup> )		
	< 350	350 to 2000	> 2000
< 1.6	260	260	260
1.6 to 2.5	260	250	245
> 2.5	250	245	245

Moisture sensitivity precautions, as indicated on the packing, must be respected at all times.

Studies have shown that small packages reach higher temperatures during reflow soldering, see [Figure 23](#).



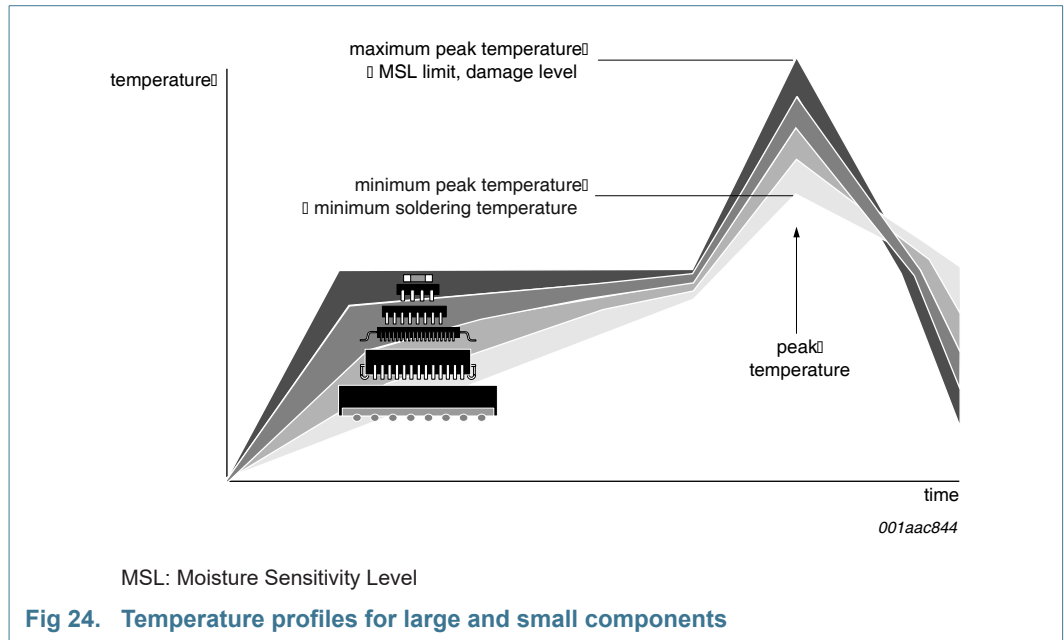

For further information on temperature profiles, refer to Application Note AN10366 “Lead less package surface mount reflow soldering description”.

## 17. Abbreviations

Table 52. Abbreviations

Acronym	Description
ADC	Analog to Digital Converter
ADE	Antenna diversity Even
ADO	Antenna diversity Odd
AES	Advanced Encryption Standard
AGC	Automatic Gain Control
API	Application Program Interface
APT	Analog Peripheral Timer
BOM	Bill Of Material
BOR	Brown-Out Reset
CCA	Clear Channel Assessment
CCM	Counter with CBC-MAC
CDM	Charged Device Model
CLK	CLock
CPU	Central Processing Unit
CRC	Cyclic redundancy Check
CSMA/CA	Carrier Sense Multiple Access with Collision Avoidance
CTS	Clear-To-Send
CW	Continuous Wave
DALI	Digitally Addressable Lighting Interface
DC	Direct current
DIO	Digital Input Output
DMA	Direct memory Access
DO	Digital Output
ED	Energy Detection
EEPROM	Electrically-Erasable Programmable Read Only Memory
ESR	Equivalent Series Resistance
FIFO	First In First Out
GP	General Purpose
GPIO	General Purpose Input Output
HBM	Human Body Model
HS	High Speed
HVQFN	Heatsink Very-thin Quad Flat No-Leads
ID	IDentification
IF	Intermediate frequency
IO	Input Output
IPC	Interconnecting and Packaging Electronic Circuits
JTAG	Joint Test Action Group
LNA	Low Noise Amplifier
LQI	Link Quality Indication

Table 52. Abbreviations ...continued

Acronym	Description
LSB	Low Significant Bit
MAC	Media Access Control
MSB	Most Significant Bit
MSIF	Master Serial InterFace
MSL	Moisture sensitivity level
NACK	Not ACKnowledge
NFET	Negative Field Effect Transistor
NRZ	Non-Return-to-Zero
NVIC	Nested Vector Interrupt Controller
OOK	On-Off Key
OTA	Over-The-Air
OTP	One Time Programmable
PA	Power Amplifier
PAN	Personal Area Network
PCB	Printed-Circuit Board
PDM	Persistent Data Manager
PHY	PHYSical
PLL	Phase-Locked Loop
POR	Power-On Reset
PPF	Palladium Pre Plated
PWM	Pulse Width Modulation
RAM	Random Access Memory
RC	Remote Control
RF	Radio Frequency
RF4CE	Radio frequency for Consumer Electronic
RoHS	Restriction of Hazardous Substances
RSSI	Receive Signal Strength Indication
RTS	Request-To-Send
RTOS	Real-Time Operating System
RTZ	Return-To-Zero
RX	Received
SCL	Serial CLock
SDA	Serial DatA
SDK	Software Developer's Kit
SMbus	System Management bus
SMDs	Surface Mount Devices
SMPS	Switched Mode Power Supply
SPDT	Single-Pole Double-Throw
SPI-bus	Serial Peripheral Interface -bus
STSD	Slave Transmitter Stop Detect
SSIF	Slave Serial InterFace

Table 52. Abbreviations ...continued

Acronym	Description
SVM	Supply Voltage Monitor
SYNTH	SYNTHesizer
SysTick	System Tick timer
TAF	Transmitter Arbitration Failure
TCM	Tightly-Coupled Memory
TX	Transmit
UART	Universal Asynchronous Receiver Transmitter
VCO	Voltage Controlled Oscillator
VTOR	Vector Table Offset Register
WPD	Wideband Power Detector

## 18. References

- [1] **Bluetooth SIG Core 5.0 specification** — Bluetooth Test Specification RF-PHY.TS
- [2] **Wireless Connectivity** — <http://www.nxp.com/products/wireless-connectivity:WIRELESS-CONNECTIVITY>
- [3] K32W041A/K32W041AM User Manual

## 19. Revision history

**Table 53. Revision history**

Document ID	Release date	Data sheet status	Change notice	Supersedes
K32W041AM v1.1	06/2021	Objective data sheet	-	-
Modifications:	<ul style="list-style-type: none"> <li>Updated to “8-input 12-bit ADC, 190 ksamples/s (Max.)” in the <a href="#">Section 2.3 “Microcontroller features”</a>.</li> <li>Updated BOD as wake-up source to exit Deep sleep and Power-down in <a href="#">Table 7 “Power mode wake-up sources”</a>.</li> <li>Updated to “Conversion rate 190 ksamples/s (Max.) for 12-bit resolution” in the <a href="#">Section 8.15 “12-bit general purpose ADC”</a>.</li> </ul>			
K32W041AM v1.0	04/2021	Objective data sheet	-	-
Modifications:	<ul style="list-style-type: none"> <li>Initial public release.</li> </ul>			

## 20. Legal information

### 20.1 Data sheet status

Document status <sup>[1][2]</sup>	Product status <sup>[3]</sup>	Definition
Objective [short] data sheet	Development	This document contains data from the objective specification for product development.
Preliminary [short] data sheet	Qualification	This document contains data from the preliminary specification.
Product [short] data sheet	Production	This document contains the product specification.

[1] Please consult the most recently issued document before initiating or completing a design.

[2] The term 'short data sheet' is explained in section "Definitions".

[3] The product status of device(s) described in this document may have changed since this document was published and may differ in case of multiple devices. The latest product status information is available on the Internet at URL <http://www.nxp.com>.

## 21. Tables

Table 1. Ordering information	4	Table 26. Temperature sensor	61
Table 2. Marking codes	4	Table 27. Flash memory	61
Table 3. Pin descriptions	7	Table 28. Internal serial flash memory	61
Table 4. Pin descriptions	14	Table 29. Dynamic characteristic: I/O pins <sup>[1]</sup>	62
Table 5. Pin properties	20	Table 30. Wake-up timing	63
Table 6: Abbreviation used in the <a href="#">Table 6</a> .	21	Table 31. SPI master timing	63
Table 7. Power mode wake-up sources	31	Table 32. SPI slave timing	64
Table 8. Allowed timer usage in different power modes	34	Table 33. USART master timing (in synchronous mode)	65
Table 9. Component descriptions about <a href="#">Figure 10</a> .	50	Table 34. USART slave timing (in synchronous mode)	65
Table 10. Limiting values	51	Table 35. SPIFI timing	66
Table 11. Operating conditions	53	Table 36. PWM timing	67
Table 12. Thermal characteristics	53	Table 37. DMIC timing	67
Table 13. Typical current consumption in Low-power mode characteristics	54	Table 38. Clock of ISO7816	68
Table 14. Typical current consumption in Active mode characteristics	54	Table 39. Input output of ISO7816	68
Table 15. Typical CPU and peripherals current consumption characteristics	55	Table 40. I <sup>2</sup> C timing	69
Table 16. Power consumption characteristics in-package Flash memory	55	Table 41. GPIO pin timing	70
Table 17. IO characteristics	55	Table 42. RF port characteristics	70
Table 18. Externally applied reset	57	Table 43. Radio transceiver characteristics: +25 °C	71
Table 19. Analog to Digital Converters	58	Table 44. Radio transceiver characteristics: -40 °C	75
Table 20. Comparator	59	Table 45. Radio transceiver characteristics: +85 °C	79
Table 21. 32 kHz free running oscillator	59	Table 46. RF port characteristics	83
Table 22. 1 MHz free running oscillator	59	Table 47. Radio transceiver characteristics: +25 °C	83
Table 23. 32 kHz crystal oscillator	59	Table 48. Radio transceiver characteristics: -40 °C	89
Table 24. 32 MHz crystal oscillator	60	Table 49. Radio transceiver characteristics: +85 °C	95
Table 25. High-speed free running oscillator	60	Table 50. SnPb eutectic process (from J-STD-020D)	104
		Table 51. Lead-free process (from J-STD-020D)	104
		Table 52. Abbreviations	106
		Table 53. Revision history	109

## 22. Figures

Fig 1. K32W041A high level hardware block diagram	5	Fig 23. Package outline SOT618-1 HVQFN40	102
Fig 2. K32W041AM high level hardware block diagram	6	Fig 24. Temperature profiles for large and small components	105
Fig 3. Pin configuration	7		
Fig 4. Pin configuration	14		
Fig 5. K32W041AM main memory map	24		
Fig 6. K32W041A main memory map	25		
Fig 7. Radio architecture	42		
Fig 8. Modem system diagram	44		
Fig 9. Baseband processor system diagram	45		
Fig 10. Simple antenna diversity implementation using external RF switch	47		
Fig 11. Application diagram – battery powered solution	50		
Fig 12. Power-up ramp	52		
Fig 13. Minimum V <sub>BAT</sub> rise time vs temperature	52		
Fig 14. Maximum V <sub>BAT</sub> slope vs temperature	53		
Fig 15. Reset signal timing	58		
Fig 16. Output timing measurement condition	63		
Fig 17. SPI master interface timings	64		
Fig 18. SPI slave interface timings	65		
Fig 19. USART interface timings	66		
Fig 20. SPIFI interface timings	67		
Fig 21. DMIC interface timings	68		
Fig 22. I <sup>2</sup> C interface timings	70		

## 23. Contents

<b>1</b>	<b>General description</b> . . . . .	<b>1</b>	8.9	PWM . . . . .	33
<b>2</b>	<b>Features and benefits</b> . . . . .	<b>1</b>	8.10	Timers . . . . .	33
2.1	Benefits . . . . .	1	8.10.1	Counter/Timers . . . . .	34
2.2	Radio features . . . . .	1	8.10.1.1	Features . . . . .	34
2.3	Microcontroller features . . . . .	2	8.10.1.2	General description . . . . .	35
2.4	Low power features . . . . .	3	8.10.2	Watchdog timer . . . . .	35
<b>3</b>	<b>Applications</b> . . . . .	<b>4</b>	8.10.3	Real-Time Clock (RTC) . . . . .	36
<b>4</b>	<b>Ordering information</b> . . . . .	<b>4</b>	8.10.3.1	Features . . . . .	36
<b>5</b>	<b>Marking</b> . . . . .	<b>4</b>	8.10.3.2	General description . . . . .	36
<b>6</b>	<b>Block diagram</b> . . . . .	<b>5</b>	8.10.4	Low Power Wake-up Timers . . . . .	37
<b>7</b>	<b>Pinning information</b> . . . . .	<b>7</b>	8.11	USART . . . . .	37
7.1	K32W041A . . . . .	7	8.12	Serial Peripheral Interfaces-bus (SPI-bus) . . . . .	38
7.1.1	Pinning . . . . .	7	8.13	I <sup>2</sup> C-bus interfaces . . . . .	38
7.1.2	Pin description . . . . .	7	8.14	DMIC interface . . . . .	39
7.2	K32W041AM . . . . .	14	8.15	12-bit general purpose ADC . . . . .	39
7.2.1	Pinning . . . . .	14	8.16	Temperature sensor . . . . .	40
7.2.2	Pin description . . . . .	14	8.17	Analog comparator . . . . .	40
7.3	Pin properties . . . . .	20	8.18	Infra-Red Modulator . . . . .	41
<b>8</b>	<b>Functional description</b> . . . . .	<b>22</b>	8.19	Serial Wire Debug (SWD) . . . . .	41
8.1	Application CPU . . . . .	22	8.19.1	Features . . . . .	41
8.1.1	Arm Cortex-M4 processor . . . . .	22	8.19.2	Basic configuration . . . . .	41
8.1.2	Memory Protection Unit . . . . .	23	8.20	Wireless transceiver . . . . .	41
8.1.3	System Tick Timer (SysTick) . . . . .	23	8.20.1	Radio features . . . . .	43
8.1.4	Nested Vector Interrupt controller (NVIC) . . . . .	23	8.20.2	Modem . . . . .	43
8.1.4.1	Features . . . . .	23	8.20.3	IEEE 802.15.4 baseband processor . . . . .	44
8.1.4.2	General description . . . . .	23	8.20.3.1	Transmit . . . . .	45
8.2	Memory . . . . .	23	8.20.3.2	Reception . . . . .	45
8.2.1	SRAM . . . . .	26	8.20.3.3	Auto acknowledge . . . . .	46
8.2.2	SRAM usage . . . . .	26	8.20.3.4	Security . . . . .	46
8.2.3	FLASH . . . . .	26	8.20.4	Bluetooth Low Energy link layer . . . . .	46
8.2.4	AHB multilayer matrix . . . . .	26	8.20.5	Antenna diversity . . . . .	46
8.3	System clocks . . . . .	26	8.20.6	Radio usage . . . . .	47
8.3.1	32 kHz clock . . . . .	27	8.21	AES engine . . . . .	47
8.3.2	High frequency system clock . . . . .	27	8.22	SPI-bus Flash Interface (SPIFI) . . . . .	48
8.3.3	1 MHz FRO . . . . .	27	8.23	Hash module . . . . .	48
8.4	Resets and brownout . . . . .	27	8.24	ISO7816 smart card interface . . . . .	48
8.4.1	External reset . . . . .	28	8.25	Random number generator . . . . .	48
8.4.2	Software reset . . . . .	28	8.26	Data Flash . . . . .	49
8.4.3	Watchdog timer . . . . .	28	<b>9</b>	<b>Application design-in information</b> . . . . .	<b>49</b>
8.4.4	Arm system reset . . . . .	28	9.1	K32W041A/K32W041AM module reference designs . . . . .	49
8.5	System configuration (SYSCON) . . . . .	28	9.2	Schematic diagram . . . . .	49
8.6	Power management . . . . .	29	<b>10</b>	<b>Limiting values</b> . . . . .	<b>51</b>
8.6.1	Power supply . . . . .	29	<b>11</b>	<b>Recommended operating conditions</b> . . . . .	<b>53</b>
8.6.2	Power modes . . . . .	29	<b>12</b>	<b>Thermal characteristics</b> . . . . .	<b>53</b>
8.6.2.1	Active mode . . . . .	30	<b>13</b>	<b>Static characteristics</b> . . . . .	<b>54</b>
8.6.2.2	Sleep mode . . . . .	30	13.1	Power consumption in Low-power mode . . . . .	54
8.6.2.3	Deep-sleep mode . . . . .	30	13.2	Power consumption in Active mode . . . . .	54
8.6.2.4	Power-down mode . . . . .	30	13.3	Power consumption in-package Flash memory . . . . .	55
8.6.2.5	Deep power-down mode . . . . .	30	13.4	IO characteristics . . . . .	55
8.6.2.6	Wake-up sources . . . . .	30	<b>14</b>	<b>Dynamic characteristics</b> . . . . .	<b>57</b>
8.7	Digital I/O . . . . .	31	14.1	AC characteristics . . . . .	57
8.7.1	Features . . . . .	31	14.1.1	Reset and Supply Voltage Monitor . . . . .	57
8.7.2	General description . . . . .	32			
8.8	DMA controller . . . . .	32			



14.1.2	Analog to Digital Converters . . . . .	58
14.1.3	Comparator . . . . .	59
14.1.4	32 kHz free running oscillator . . . . .	59
14.1.5	1 MHz free running oscillator . . . . .	59
14.1.6	32 kHz crystal oscillator . . . . .	59
14.1.7	32 MHz crystal oscillator . . . . .	60
14.1.8	High-speed free running oscillator . . . . .	60
14.1.9	Temperature sensor . . . . .	61
14.2	Flash memory . . . . .	61
14.3	Internal Data Flash on K32W041AM . . . . .	61
14.4	IO pins . . . . .	62
14.5	Wake-up timing . . . . .	63
14.6	SPI timing . . . . .	63
14.7	USART timing . . . . .	65
14.8	SPIFI timing . . . . .	66
14.9	PWM timing . . . . .	67
14.10	DMIC timing . . . . .	67
14.11	ISO7816 . . . . .	68
14.12	I <sup>2</sup> C timing . . . . .	69
14.13	GPIO pin timing . . . . .	70
14.14	Radio transceiver (IEEE 802.15.4) . . . . .	70
14.15	Radio transceiver (Bluetooth Low Energy) . . . . .	83
<b>15</b>	<b>Package outline . . . . .</b>	<b>102</b>
<b>16</b>	<b>Soldering of SMD packages . . . . .</b>	<b>103</b>
16.1	Introduction to soldering . . . . .	103
16.2	Wave and reflow soldering . . . . .	103
16.3	Wave soldering . . . . .	103
16.4	Reflow soldering . . . . .	104
<b>17</b>	<b>Abbreviations . . . . .</b>	<b>106</b>
<b>18</b>	<b>References . . . . .</b>	<b>108</b>
<b>19</b>	<b>Revision history . . . . .</b>	<b>109</b>
<b>20</b>	<b>Legal information . . . . .</b>	<b>110</b>
20.1	Data sheet status . . . . .	110
<b>21</b>	<b>Tables . . . . .</b>	<b>111</b>
<b>22</b>	<b>Figures . . . . .</b>	<b>111</b>
<b>23</b>	<b>Contents . . . . .</b>	<b>112</b>

## **How To Reach Us**

### **Home Page:**

[nxp.com](http://nxp.com)

### **Web Support:**

[nxp.com/support](http://nxp.com/support)

**Limited warranty and liability** — Information in this document is believed to be accurate and reliable. However, NXP Semiconductors does not give any representations or warranties, expressed or implied, as to the accuracy or completeness of such information and shall have no liability for the consequences of use of such information. NXP Semiconductors takes no responsibility for the content in this document if provided by an information source outside of NXP Semiconductors. In no event shall NXP Semiconductors be liable for any indirect, incidental, punitive, special or consequential damages (including - without limitation - lost profits, lost savings, business interruption, costs related to the removal or replacement of any products or rework charges) whether or not such damages are based on tort (including negligence), warranty, breach of contract or any other legal theory.

Notwithstanding any damages that customer might incur for any reason whatsoever, NXP Semiconductors' aggregate and cumulative liability towards customer for the products described herein shall be limited in accordance with the Terms and conditions of commercial sale of NXP Semiconductors.

**Right to make changes** - NXP Semiconductors reserves the right to make changes to information published in this document, including without limitation specifications and product descriptions, at any time and without notice. This document supersedes and replaces all information supplied prior to the publication hereof.

**Security** — Customer understands that all NXP products may be subject to unidentified or documented vulnerabilities. Customer is responsible for the design and operation of its applications and products throughout their lifecycles to reduce the effect of these vulnerabilities on customer's applications and products. Customer's responsibility also extends to other open and/or proprietary technologies supported by NXP products for use in customer's applications. NXP accepts no liability for any vulnerability. Customer should regularly check security updates from NXP and follow up appropriately.

Customer shall select products with security features that best meet rules, regulations, and standards of the intended application and make the ultimate design decisions regarding its products and is solely responsible for compliance with all legal, regulatory, and security related requirements concerning its products, regardless of any information or support that may be provided by NXP. NXP has a Product Security Incident Response Team (PSIRT) (reachable at [PSIRT@nxp.com](mailto:PSIRT@nxp.com)) that manages the investigation, reporting, and solution release to security vulnerabilities of NXP products.

**Suitability for use** — NXP Semiconductors products are not designed, authorized or warranted to be suitable for use in life support, life-critical or safety-critical systems or equipment, nor in applications where failure or malfunction of an NXP Semiconductors product can reasonably be expected to result in personal injury, death or severe property or environmental damage. NXP Semiconductors and its suppliers accept no liability for inclusion and/or use of NXP Semiconductors products in such equipment or applications and therefore such inclusion and/or use is at the customer's own risk.

**Non-automotive qualified products** — Unless this data sheet expressly states that this specific NXP Semiconductors product is automotive qualified, the product is not suitable for automotive use. It is neither qualified nor tested in accordance with automotive testing or application requirements. NXP Semiconductors accepts no liability for inclusion and/or use of non-automotive qualified products in automotive equipment or applications.

In the event that customer uses the product for design-in and use in automotive applications to automotive specifications and standards, customer (a) shall use the product without NXP Semiconductors' warranty of the product for such automotive applications, use and specifications, and (b) whenever customer uses the product for automotive applications beyond NXP Semiconductors' specifications such use shall be solely at customer's own risk, and (c) customer fully indemnifies NXP Semiconductors for any liability, damages or failed product claims resulting from customer design and use of the product for automotive applications beyond NXP Semiconductors' standard warranty and NXP Semiconductors' product specifications.

**Applications** — Applications that are described herein for any of these products are for illustrative purposes only. NXP Semiconductors makes no representation or warranty that such applications will be suitable for the specified use without further testing or modification.

Customers are responsible for the design and operation of their applications and products using NXP Semiconductors products, and NXP Semiconductors accepts no liability for any assistance with applications or customer product

*Table continues on the next page...*

design. It is customer's sole responsibility to determine whether the NXP Semiconductors product is suitable and fit for the customer's applications and products planned, as well as for the planned application and use of customer's third party customer(s). Customers should provide appropriate design and operating safeguards to minimize the risks associated with their applications and products.

NXP Semiconductors does not accept any liability related to any default, damage, costs or problem which is based on any weakness or default in the customer's applications or products, or the application or use by customer's third party customer(s). Customer is responsible for doing all necessary testing for the customer's applications and products using NXP Semiconductors products in order to avoid a default of the applications and the products or of the application or use by customer's third party customer(s). NXP does not accept any liability in this respect.

**Limiting values** — Stress above one or more limiting values (as defined in the Absolute Maximum Ratings System of IEC 60134) will cause permanent damage to the device. Limiting values are stress ratings only and (proper) operation of the device at these or any other conditions above those given in the Recommended operating conditions section (if present) or the Characteristics sections of this document is not warranted. Constant or repeated exposure to limiting values will permanently and irreversibly affect the quality and reliability of the device.

**Terms and conditions of commercial sale** — NXP Semiconductors products are sold subject to the general terms and conditions of commercial sale, as published at <http://www.nxp.com/profile/terms>, unless otherwise agreed in a valid written individual agreement. In case an individual agreement is concluded only the terms and conditions of the respective agreement shall apply. NXP Semiconductors hereby expressly objects to applying the customer's general terms and conditions with regard to the purchase of NXP Semiconductors products by customer.

**Hazardous voltage** — Although basic supply voltages of the product may be much lower, circuit voltages up to 60 V may appear when operating this product, depending on settings and application. Customers incorporating or otherwise using these products in applications where such high voltages may appear during operation, assembly, test etc. of such application, do so at their own risk. Customers agree to fully indemnify NXP Semiconductors for any damages resulting from or in connection with such high voltages. Furthermore, customers are drawn to safety standards (IEC 950, EN 60950, CENELEC, ISO, etc.) and other (legal) requirements applying to such high voltages.

**Export control** — This document as well as the item(s) described herein may be subject to export control regulations. Export might require a prior authorization from competent authorities.

NXP, the NXP logo, NXP SECURE CONNECTIONS FOR A SMARTER WORLD, EdgeLock, are trademarks of NXP B.V. All other product or service names are the property of their respective owners. AMBA, Arm, Arm7, Arm7TDMI, Arm9, Arm11, Artisan, big.LITTLE, Cordio, CoreLink, CoreSight, Cortex, DesignStart, DynamIQ, Jazelle, Keil, Mali, Mbed, Mbed Enabled, NEON, POP, RealView, SecurCore, Socrates, Thumb, TrustZone, ULINK, ULINK2, ULINK-ME, ULINK-PLUS, ULINKpro,  $\mu$ Vision, Versatile are trademarks or registered trademarks of Arm Limited (or its subsidiaries) in the US and/or elsewhere. The related technology may be protected by any or all of patents, copyrights, designs and trade secrets. All rights reserved.

© NXP B.V. 2021.

All rights reserved.

For more information, please visit: <http://www.nxp.com>

For sales office addresses, please send an email to: [salesaddresses@nxp.com](mailto:salesaddresses@nxp.com)

Date of release: 06/2021

Document Identifier: K32W041AM



## X-ON Electronics

Largest Supplier of Electrical and Electronic Components

*Click to view similar products for [RF Microcontrollers - MCU category](#):*

*Click to view products by [NXP manufacturer](#):*

Other Similar products are found below :

[BCM20704UA1KFFB1G](#) [BCM20733A3KFB1G](#) [BCM20705B0KWFBG](#) [BCM20706UA1KFFB1G](#) [BCM20706UA1KFFB4G](#)  
[BCM20734UA1KFFB3G](#) [BCM20736A1KML2G](#) [CYBL11172-56LQXI](#) [RY7011A0000DZ00#002](#) [CYW20732I](#) [CYW20748A0KFBGT](#)  
[CYW20738A2KML3G](#) [CYW20732E](#) [CYW20702B0KWFBG](#) [BCM20730A1KMLG](#) [CC1310F32RGZR](#) [CC1310F32RSMR](#)  
[PCF7952ATT/M1CC15](#), [ATMEGA64RFR2-ZF](#) [CYW20707UA1KFFB4G](#) [BCM20735PKML1G](#) [JN5168/001,515](#) [STA2058](#)  
[CC1310F128RHBR](#) [ADUCRF101BCPZ128R7](#) [ADUCRF101BCPZ128](#) [ATMEGA1284RFR2-ZU](#) [ATMEGA128RFA1-ZU](#)  
[ATMEGA64RZAV-10MU](#) [CY8C4127LQI-BL483](#) [MAX32666GWP+](#) [CYW20730A2KML2G](#) [ATSAMR21E16A-MU](#) [ATMEGA64RFR2-](#)  
[ZUR](#) [ATMEGA128RFA1-ZUR](#) [RFPIC12F675H-I/SS](#) [JN5169001Z](#) [CYBL11171-56LQXI](#) [CYBL11573-56LQXI](#) [CYBL10161-56LQXI](#)  
[EZR32LG230F64R63G-C0](#) [MKW30Z160VHM4](#) [SI4010-C2-GSR](#) [EZR32LG230F128R55G-B0](#) [EZR32WG330F256R69G-B0](#)  
[EZR32WG230F128R55G-B0](#) [EZR32WG230F256R55G-B0](#) [EZR32WG330F64R55G-B0](#) [Si1063-A-GM](#) [Si1081-A-GM](#)