

KIT33908MBEVBE Evaluation Mother Board

Featuring the MC33908 Safe System Basis Chip with Buck and Boost DC/DC up to 1.5 A

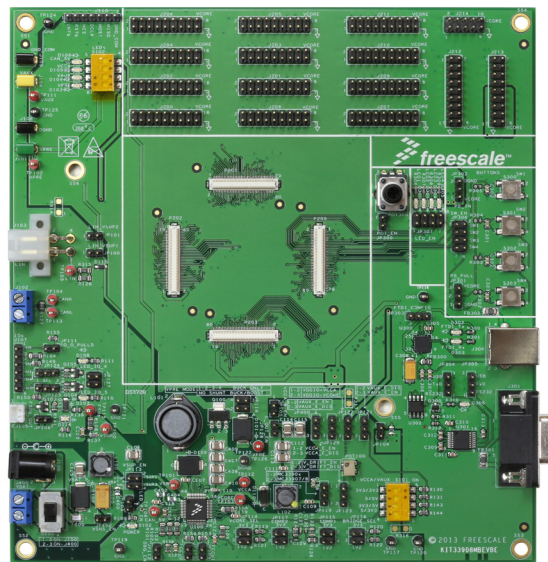

Figure 1. KIT33908MBEVBE Evaluation Board

Contents

1 Kit Contents/Packing List	2
2 Jump Start	2
3 Important Notice	3
4 Introduction	4
5 Evaluation Board Features	4
6 MC33908 Device Features	5
7 Required Equipment	5
8 Evaluation Board Configuration	6
9 Setting Up and Using the Hardware	8
10 Evaluation Board Hardware Description	8
11 Power Supply Scheme when Using Daughterboard MPC5643L	20
12 Schematic	21
13 Board Layout	24
14 Bill of Materials	32
15 References	35
16 Revision History	36

1 Kit Contents/Packing List

- Assembled and tested evaluation board/module in anti-static bag. The board is preloaded with demo software
- Warranty card

2 Jump Start

- Go to www.freescale.com/analogtools
- Locate your kit
- Review your Tool Summary Page
- Look for



Jump Start Your Design

- Download documents, software, and other information

3 Important Notice

Freescale provides the enclosed product(s) under the following conditions:

This evaluation kit is intended for use of ENGINEERING DEVELOPMENT OR EVALUATION PURPOSES ONLY. It is provided as a sample IC pre-soldered to a printed circuit board to make it easier to access inputs, outputs, and supply terminals. This evaluation board may be used with any development system or other source of I/O signals by simply connecting it to the host MCU or computer board via off-the-shelf cables. This evaluation board is not a Reference Design and is not intended to represent a final design recommendation for any particular application. Final device in an application will be heavily dependent on proper printed circuit board layout and heat sinking design as well as attention to supply filtering, transient suppression, and I/O signal quality.

The goods provided may not be complete in terms of required design, marketing, and or manufacturing related protective considerations, including product safety measures typically found in the end product incorporating the goods. Due to the open construction of the product, it is the user's responsibility to take any and all appropriate precautions with regard to electrostatic discharge. In order to minimize risks associated with the customers applications, adequate design and operating safeguards must be provided by the customer to minimize inherent or procedural hazards. For any safety concerns, contact Freescale sales and technical support services.

Should this evaluation kit not meet the specifications indicated in the kit, it may be returned within 30 days from the date of delivery and will be replaced by a new kit.

Freescale reserves the right to make changes without further notice to any products herein. Freescale makes no warranty, representation or guarantee regarding the suitability of its products for any particular purpose, nor does Freescale assume any liability arising out of the application or use of any product or circuit, and specifically disclaims any and all liability, including without limitation consequential or incidental damages. "Typical" parameters can and do vary in different applications and actual performance may vary over time. All operating parameters, including "Typical", must be validated for each customer application by customer's technical experts.

Freescale does not convey any license under its patent rights nor the rights of others. Freescale products are not designed, intended, or authorized for use as components in systems intended for surgical implant into the body, or other applications intended to support or sustain life, or for any other application in which the failure of the Freescale product could create a situation where personal injury or death may occur.

Should the Buyer purchase or use Freescale products for any such unintended or unauthorized application, the Buyer shall indemnify and hold Freescale and its officers, employees, subsidiaries, affiliates, and distributors harmless against all claims, costs, damages, and expenses, and reasonable attorney fees arising out of, directly or indirectly, any claim of personal injury or death associated with such unintended or unauthorized use, even if such claim alleges that Freescale was negligent regarding the design or manufacture of the part. Freescale™ and the Freescale logo are trademarks of Freescale Semiconductor, Inc. All other product or service names are the property of their respective owners.

© Freescale Semiconductor, Inc. 2014

4 Introduction

The KIT33908MBEVBE evaluation mother board demonstrates the functionality of the MC33908 power system basis chip. This SMARTMOS IC is equipped with an Intelligent Power Management System including safety features targeting the latest ISO26262 automotive functional safety standard. The power management and MCU peripherals are located on the motherboard described in this user guide. The motherboard can be used with different daughter boards. The daughter board is selected according to the preferred MCU along with its associated circuitry. The enhanced evaluation board system includes demonstration software, which facilitates communication between the motherboard's power management functions and daughter board's MCU. The system's advanced safety features enable it to reach the highest standard in functional safety: ASILD.

5 Evaluation Board Features

- Unique modular platform enables evaluation of different microcontrollers using the KIT33908MBEVBE and daughter board
- Switching mode power supply (SMPS) dedicated to MCU core supply: 1.2 V and 3.3 V, selectable through an external voltage, selectable through external jumpers
- Linear voltage regulator dedicated to MCU A/D reference voltage or I/Os supply (V_{CCA}). 5.0 V or 3.3 V
- Linear voltage regulator dedicated to auxiliary functions or to a sensor supply (V_{CCA} tracker or independent 5.0 V/3.3 V)
- Highly flexible SMPS pre-regulator, allowing two topologies: Non-inverting buck-boost or standard buck
- Multiple wake-up sources in low-power mode: CAN Interface, local wake pins
- Battery voltage sensing before reverse battery protection
- Enhanced safety block associated with fail-safe outputs (two active-low signals)
- SPI interface connectivity
- Configurable digital I/Os through SPI registers
- MUX output terminal for the device's internal analog signal and power supply monitoring
- SO11898 high-speed CAN interface compatibility for baud rates of 40 kB/s to 1.0 MB/s
- High EMC immunity and ESD robustness

6 MC33908 Device Features

The MC33908 is a multi-output IC, with power supply and HSCAN transceiver. This device is designed specifically with the automotive market in mind. It supports the following functions:

- Highly flexible SMPS pre-regulator, allowing two topologies: non-inverting buck-boost or standard buck
- Switching mode power supply (SMPS) dedicated to MCU core supply: 1.2 V or 3.3 V, delivering up to 1.5 A
- Linear voltage regulator dedicated to MCU A/D reference voltage or I/Os supply (V_{CCA}): 5.0 V or 3.3 V
- Linear voltage regulator dedicated to auxiliary functions or to a sensor supply (V_{CCA} tracker or independent 5.0 V/3.3 V)
- Multiple wake-up sources in low-power mode: CAN and/or I/Os
- Battery voltage sensing and multiplexer output terminal (various signal monitoring)
- Enhanced safety block associated with fail-safe outputs
- Six configurable I/Os
- ISO11898 high-speed CAN interface compatibility for baud rates of 40 kB/s to 1.0 MB/s
- High EMC immunity & ESD robustness

7 Required Equipment

- Power supply
- Oscilloscope (preferably four-channel) with current probe
- Digital multimeter
- USB-enabled PC with Windows XP or higher
- MCU daughter board

Important notice:

The mother board (KIT33908MBEVBE) is extensible by the daughter board (KITMPC5643DBEVM) and cannot operate separately. The equipment list is considered for operation with the KITMPC5643DBEVM uniquely. Two modes of operation with this platform can be distinguished:

Recommended equipment for software development:

- Power supply 12 V/3.0 A
- USB A-B cable
- P&E USB Multi-link Debugger
- USB-enabled PC

Recommended equipment for hardware development (validation of analog functionality etc.):

- Power supply: typically 12 V/3.0 A
- USB A-B cable
- USB-enabled PC

Recommended software:

- Windows 7 32-bit operating system
- MC33907_8 Graphical User Interface
(http://www.freescale.com/webapp/sps/site/prod_summary.jsp?code=KIT33907AEEVB&fpp=1&tab=Design_Tools_Tab)
- CodeWarrior IDE for Qorivva MCU family installed
(http://www.freescale.com/webapp/sps/site/prod_summary.jsp?code=CW-MPC55XX_56XX&fsrc=1)

8 Evaluation Board Configuration

8.1 Evaluation Board Configuration for Software Development

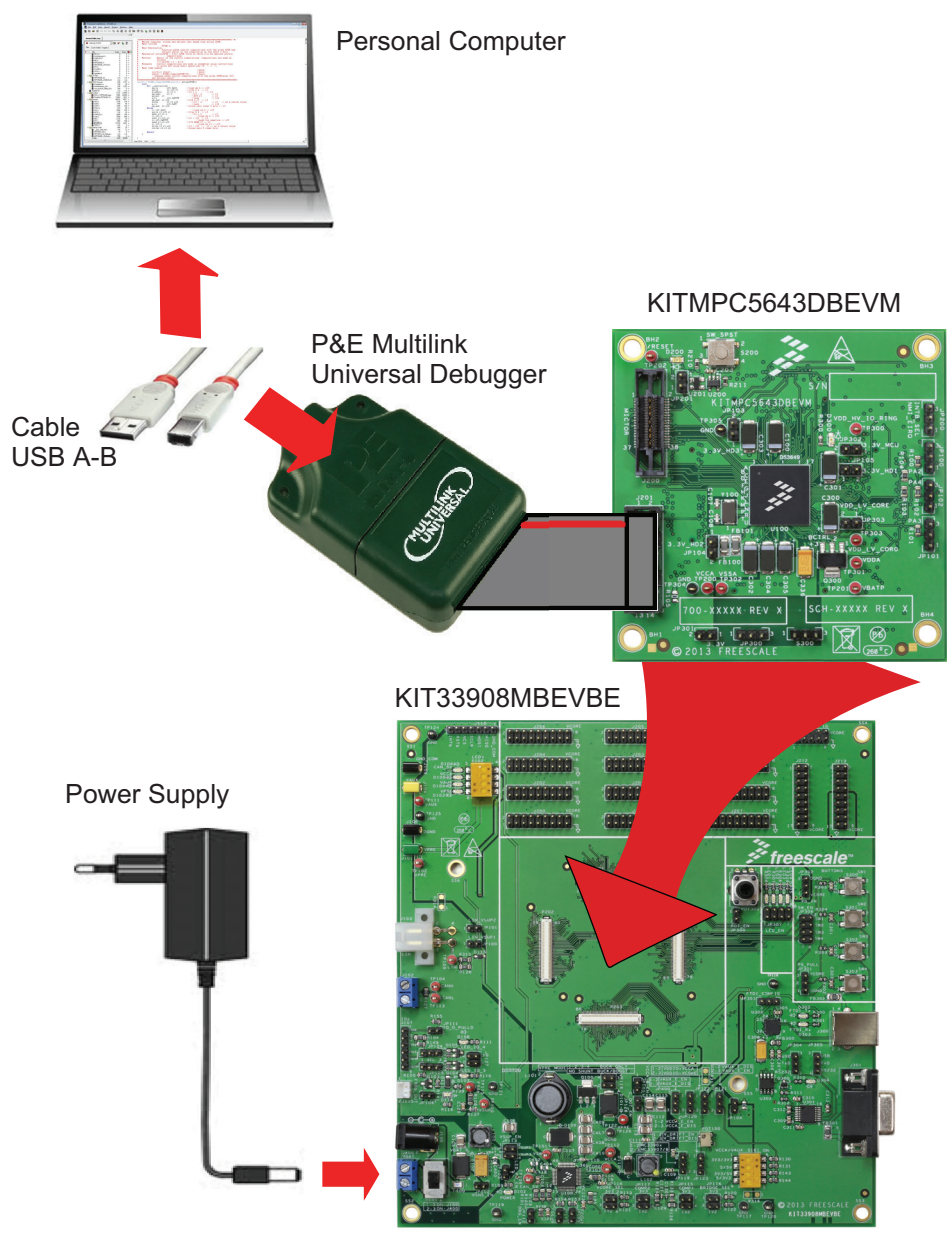

Figure 2. KIT33908MBEVBE Board Setup for Software Development

8.2 Evaluation Board Configuration for Hardware Development

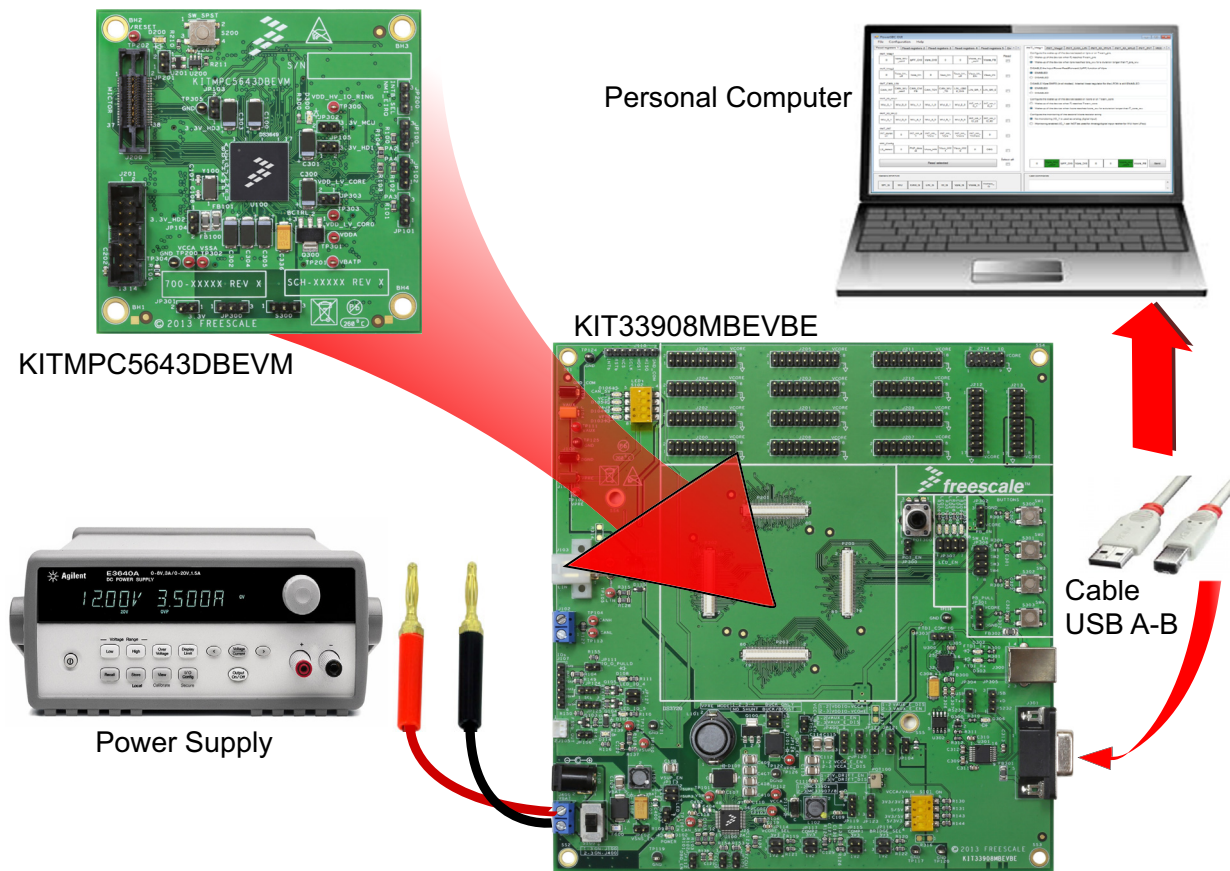

Figure 3. KIT33908MBEVBE Board Setup For Hardware Development

9 Setting Up and Using the Hardware

In order to perform the demonstration examples, first set up the evaluation board hardware and software as follows:

1. Install the MC33907_8 graphical user interface
2. Plug the daughter board onto the mother board platform (KIT33908MBEVBE)
3. Connect the power supply to the mother board and switch it on (verify the power supply's polarity)
4. Connect the mother board to the PC using USB A-B cable
5. Wait for the driver installation (after the first connection, drivers for the device have to be installed. This can take several minutes. When finished, a status message will be displayed)
6. Launch the MC33907_8 graphical user interface
7. Select the EVM button on the welcome screen to choose the enhanced evaluation board option
8. Switch to the "Read registers 5" where you should see an on-going watchdog refresh (bits of the WD_LFSR register will be blinking)

10 Evaluation Board Hardware Description

From the functional point of view, the KIT33908MBEVBE motherboard can be separated into two different sections: analog and digital. The analog part consists of the MC33908 chip and its associated circuitry. The digital part consists of the MCU peripherals.

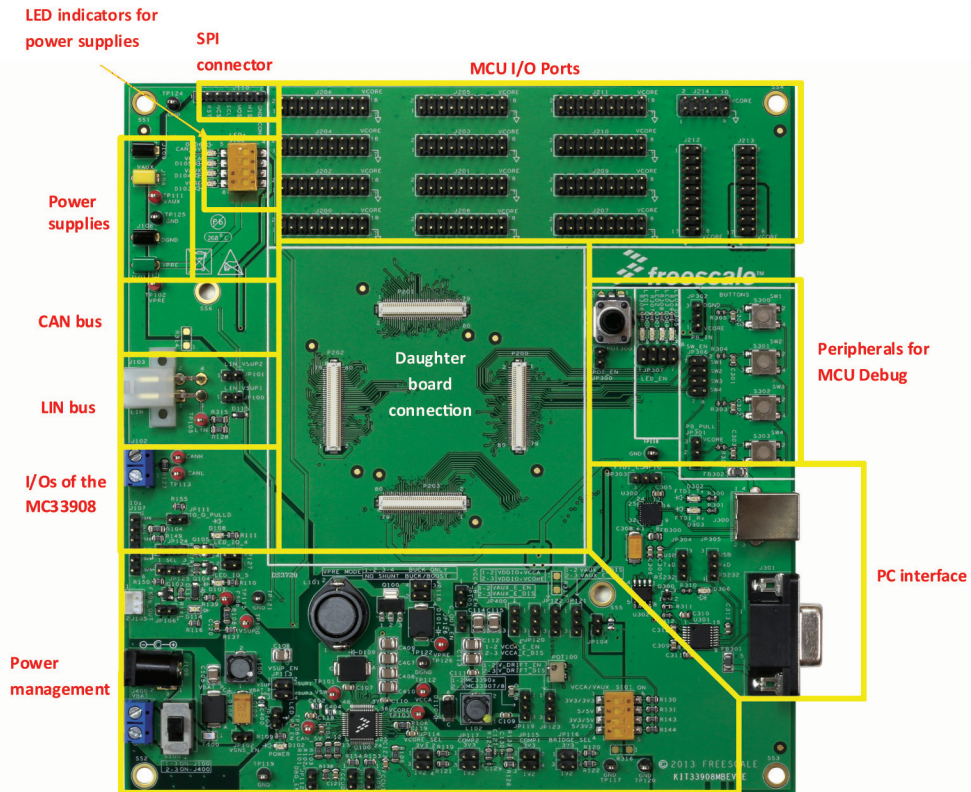

Figure 4. The KIT33908MBEVBE Enhanced Evaluation Board

10.1 The Analog Section

10.1.1 Overview

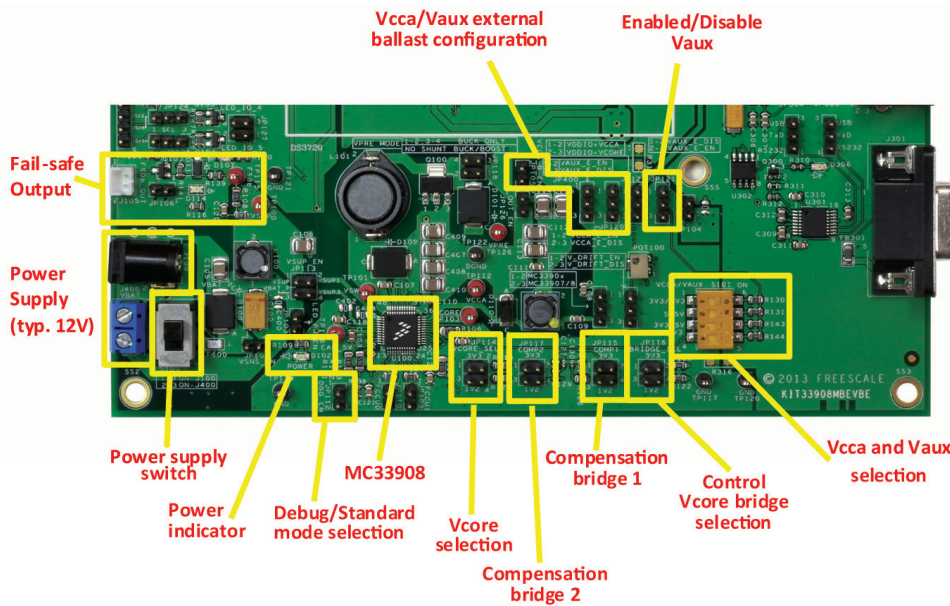

Figure 5. Power Management Section

10.1.2 V_{CORE} Output Capacitance (JP126)

Output capacitance has an impact on the feedback (FB_core), which is necessary for controlling the V_{CORE} voltage through a compensation network. For test purposes on the EVM, two different capacities are selectable due to the jumper JP126 (if the jumper is disconnected, output capacitance is set to 20 μF , otherwise to 40 μF), see [Jumper Definitions](#). These capacities simulate capacity of the real circuitry normally connected to V_{CORE} . Changing the output capacitance has an impact on a selection of the compensation network.

10.1.3 Compensation Network (JP115 & JP117)

The voltage regulator needs feedback from the V_{CORE} voltage to be able to adjust (control) output voltage. For this reason, a compensation network is implemented in the external MC33908 circuitry. Static feedback (steady-state) voltage is defined by a simple resistor bridge (given by R119/R121 and R133). Dynamic behavior of the regulator is controlled by an RC network (defined by R124, R126, C127, C130, R135, R136, C128, C129). Compensation network is shown on the [Figure 6](#). Steady-state voltage can be chosen (either 1.23 or 3.3 V). To tune the dynamic performance, the board is equipped with two different networks (possible combinations of the jumpers JP115 and JP117 are shown in the [Table 1](#)). The combinations shown in [Table 1](#) were chosen for an optimal performance for the given output voltage. The real dynamic performance can differ for different applications, and can be tuned by changing the compensation network, and by adding output capacitors (JP126).

Table 1. Compensation Network and V_{CORE} Setting

V _{CORE} (V)	Jumper Settings		
	Static Behavior	Dynamic Behavior	
	JP115	JP114	JP117
1.23	3 - 4	3 - 4	3 - 4
3.3	1 - 2	1 - 2	1 - 2

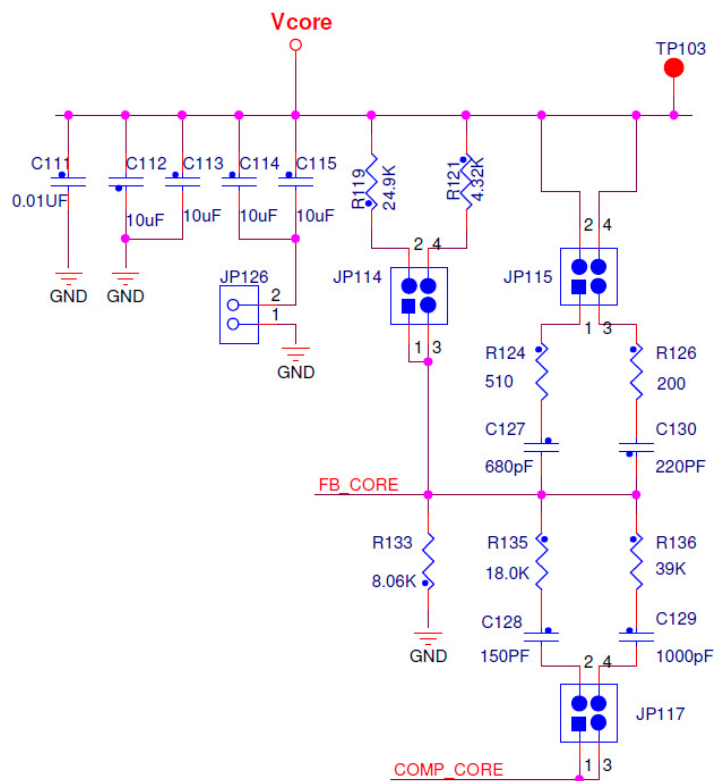

Figure 6. Compensation Network and V_{CORE} Setting Scheme

10.2 The Digital Section

All I/O ports from the MCU are accessible via the I/O ports implemented on the top of the Mother board. Pin mapping of the ports with the IOs differs depending on the type of Daughter board being used. An example of port mapping done for the MPC5643L is shown in the [Figure 7](#).

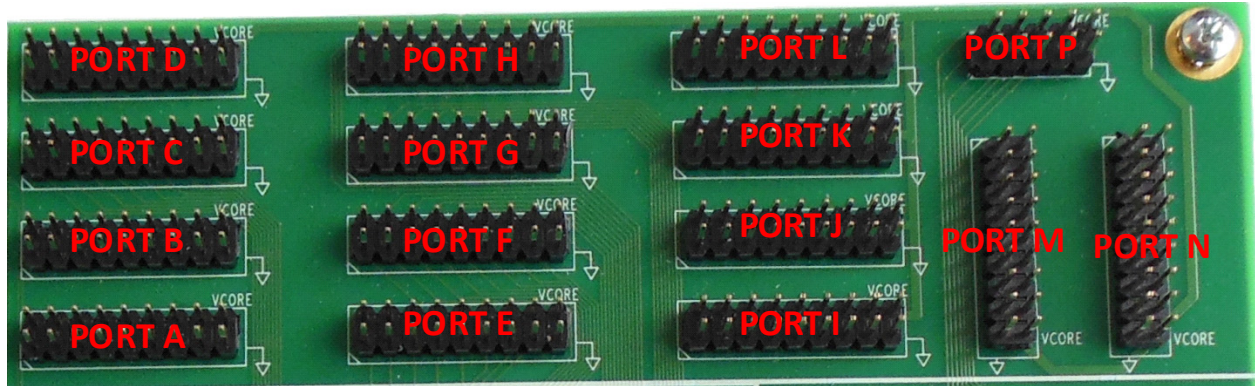

Figure 7. MCU I/Os Mapping for Daughter Board MPC5643L

10.2.1 Ports A through H

Table 2. I/O Port Mapping (when the daughter board with MPC5643L is being used)

PD1	PD3	PD5	PD7	PD9	PD11	PD13	PD15	V _{CORE}
PD0	PD2	PD4	PD6	PD8	PD10	PD12	PD14	GND

PH1	PH3	PH5	PH7	PH9	PH11	PH13	PH15	V _{CORE}
PH0	PH2	PH4	PH6	PH8	PH10	PH12	PH14	GND

PC1	PC3	PC5	PC7	PC9	PC11	PC13	PC15	V _{CORE}
PC0	PC2	PC4	PC6	PC8	PC10	PC12	PC14	GND

PG1	PG3	PG5	PG7	PG9	PG11	PG13	PG15	V _{CORE}
PG0	PG2	PG4	PG6	PG8	PG10	PG12	PG14	GND

PB1	PB3	PB5	PB7	PB9	PB11	PB13	PB15	V _{CORE}
PB0	PB2	PB4	PB6	PB8	PB10	PB12	PB14	GND

PF1	PF3	PF5	PF7	PF9	PF11	PF13	PF15	V _{CORE}
PF0	PF2	PF4	PF6	PF8	PF10	PF12	PF14	GND

PA1	PA3	PA5	PA7	PA9	PA11	PA13	PA15	V _{CORE}
PA0	PA2	PA4	PA6	PA8	PA10	PA12	PA14	GND

PE1	PE3	PE5	PE7	PE9	PE11	PE13	PE15	V _{CORE}
PE0	PE2	PE4	PE6	PE8	PE10	PE12	PE14	GND

10.2.2 Ports I through P

Table 3. I/O Port Mapping (when Daughter board with MPC5643L is being used)

PORT L									PORT P				
PL1	PL3	PL5	PL7	PL9	PL11	PL13	PL15	V _{CORE}	HP1	HP3	HP5	FCCU1	V _{CORE}
PL0	PL2	PL4	PL6	PL8	PL10	PL12	PL14	GND	HP0	HP2	HP4	FCCU0	GND

PORT K									PORT M		PORT N	
PK1	PK3	PK5	PK7	PK9	PK11	PK13	PK15	V _{CORE}	PM0	PM1	PN0	PN1
PK0	PK2	PK4	PK6	PK8	PK10	PK12	PK14	GND	PM2	PM3	PN2	PN3

PORT J									PORT M		PORT N	
PJ1	PJ3	PJ5	PJ7	PJ9	PJ11	PJ13	PJ15	V _{CORE}	PM4	PM5	PN4	PN5
PJ0	PJ2	PJ4	PJ6	PJ8	PJ10	PJ12	PJ14	GND	PM6	PM7	PN6	PN7

PORT I									PORT M		PORT N	
PI1	PI3	PI5	PI7	PI9	PI11	PI13	PI15	V _{CORE}	PM8	PM9	PN8/Vaux	PN9/Vaux
PI0	PI2	PI4	PI6	PI8	PI10	PI12	PI14	GND	PM10	PM11	PN10/Vaux	PN11/Vaux

PORT M		PORT N	
PM12	PM13	PN12/Vpre	PN13/Vpre
PM14	PM15	PN14/Vpre	PN15/Vpre
GND	V _{CORE}	GND	V _{CORE}

10.2.3 MCU peripherals

Basic peripherals such as potentiometer, LEDs and Buttons were placed for any debug purposes on the Mother board. Mapping of these peripherals on the MCU ports can differ with respect to the MCU Daughter board that is being used. For the MPC5643L these peripherals are mapped on the PORT D as shown in [Table 4](#)

Table 4. MCU Peripherals Mapping (MPC5643L daughter board)

Component	Potentiometer	Buttons				LEDs			
Name	POT	SW1	SW2	SW3	SW4	LED1	LED2	LED3	LED4
Port	PC0	PD0	PD1	PD2	PD3	PD4	PD5	PD6	PD7

10.2.4 Serial Communication Interface

For communication with the PC, the KIT33908MBEVBE is equipped with UART/USB and UART/RS232 converters (see [Table 8](#)). In one time only, one of them can be used. Choice of the interface can be done using jumpers JP304 (TxD connection) and JP305 (RxD connection). The UART/USB converter is used by default for communication with the graphical user interface (GUI). If no frame is on-going, the UART/RS232 converter goes to a low-power mode (typically after 30 s) - indicated by LED D306.

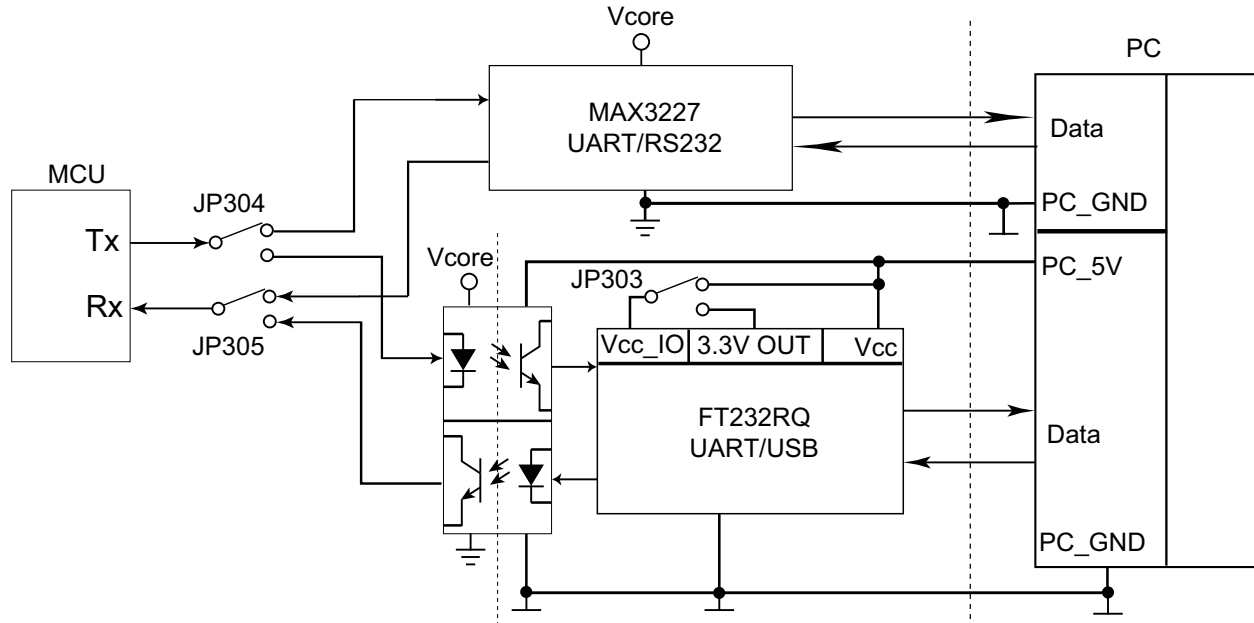

Figure 8. Serial Communication Interface

10.2.5 CAN Interface

The MC33908 is equipped by a CAN bus physical layer. Basic configuration is shown in [Table 9](#). For the MPC5643L, the CAN0 module is mapped to the physical layer (CAN0_TxD on PORTB0 and CAN0_RxD on PORTB1).

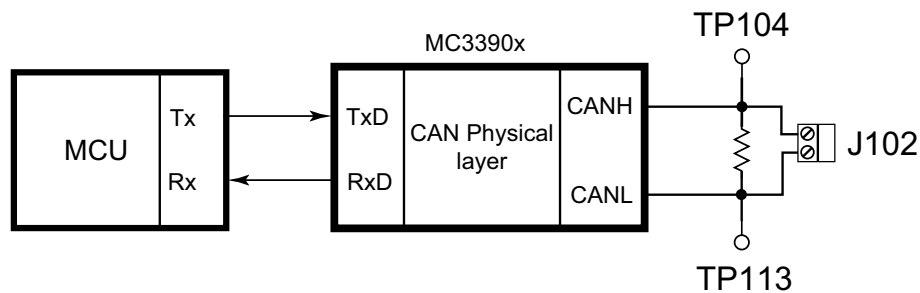

Figure 9. CAN Interface

10.3 LED Display

The following LEDs are provided as visual output devices for the KIT33908MBEVBE evaluation board:

Table 5. LED Display

Schematic Label	Name	Description
D102	Power	Power indicator
D103	V _{PRE}	Indicator of pre-regulator voltage
D104	V _{AUX}	Indicator of auxiliary power supply
D105	V _{CCA}	Indicator of ADC's power supply
D106	CAN_5V	Indicator of 5.0 V CAN voltage
D107	LED_IO_5	Indicator of IO_5 state
D108	LED_IO_4	Indicator of IO_4 state
D114	LED_FS0b	Indicator for Fail Safe output no. 0
D300	LED1	LED for MCU debug purposes
D301	LED2	LED for MCU debug purposes
D302	FTDI_Rx	UART/USB reception indicator
D303	FTDI_Tx	UART/USB transmission indicator
D304	LED3	LED for MCU debug purposes
D305	LED4	LED for MCU debug purposes
D306	RS232	UART/RS232 converter indicator ⁽¹⁾

Notes

1. Converter is active after POR state and if no frames are on-going, it is switched automatically into Low-power mode. This is typically 30 s after a POR (LED will be switched ON).

10.4 Test Point Definitions

The following test-point jumpers provide access to signals on the MC33908 IC:

Table 6. Test Point Definitions

Schematic Label	Name	Description
TP100	V _{SUP}	Supply voltage
TP101	V _{SW}	Switching voltage
TP102	V _{PRE}	Pre-regulator voltage
TP103	V _{CORE}	Core voltage for the MCU
TP104	CANH	
TP105	LIN	LIN bus
TP106	CAN_5V	5 V CAN voltage
TP111	V _{AUX}	Auxiliary power supply
TP112	V _{CCA}	ADC power supply
TP113	CANL	
TP115	FS0b	Fail Safe output no. 0
TP117	GND	Ground
TP118	GND	ground
TP119	GND	ground

Table 6. Test Point Definitions (continued)

Schematic Label	Name	Description
TP120	GND	ground
TP121	GND	ground
TP122	GND	ground
TP124	GND	ground
TP125	GND	ground

10.5 Evaluation Board Connectors

Table 7. Board Connectors (J100-J103)

Schematic Label	Description		
J100	Power supply (typically 12 V DC)		
J101	V_{PRE} – pre-regulator voltage		
J102	CAN connection		
	pin1	CANL	CANL signal after transceiver (NOT the MCU side)
	pin2	CANH	CANH signal after transceiver (NOT the MCU side)
J103	LIN connection – only for kits equipped with LIN		
	pin1	V_{SUP}	LIN bus supply voltage
	pin2	V_{SUP}	LIN bus supply voltage
	pin3	LIN	LIN after transceiver (NOT the MCU side)
	pin4	GND	Ground

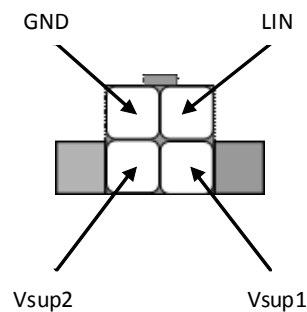

Figure 10. LIN Connector

Table 8. Jumper Board Connectors (J104-J400)

Schematic Label	Description		
J104	V _{AUX} - voltage on the auxiliary power supply		
J105	FS0b external connector		
	pin1	FS0	FS0 output amplified by transistor
	pin2	GND	Ground
J107	General Inputs/Outputs of the MC33908		
	pin1	IO_0	
	pin2	IO_1	
	pin3	IO_2	
	pin4	IO_3	
	pin5	IO_4	
	pin6	IO_5	
J108	GND - Ground		
J109	GND - Ground		
J110	MC33908 Inputs/Outputs		
	pin1	INTb	Interrupt (activated low)
	pin2	RSTb	Reset (activated low)
	pin3	NCS	SPI - Chip Select (activated low)
	pin4	SCLK	SPI - Clock
	pin5	MOSI	SPI - Master Output Slave Input
	pin6	MISO	SPI - Master Input Slave Output
	pin7	GND	ground
J200	PORTA		
J201	PORTF		
J202	PORTB		
J203	PORTG		
J204	PORTC		
J205	PORTH		
J206	PORTD		
J207	PORTI		
J208	PORTE		
J209	PORTJ		
J210	PORTK		
J211	PORTL		
J212	PORTM		
J213	PORTN		
J214	PORTP		
J300	USB - PC interface		
J301	RS232 - PC interface		
J400	Power supply DC 12 V This connector should be used to supply EVM from protected power supply.		
	pin1	GND	Ground
	pin2	VBAT	Positive supply

10.6 Jumper Definitions

The following table defines the evaluation board jumper positions and explains their functions. (The default settings are shown in **bold**.)

Table 9. Jumper Definitions

Schematic Label	Description	
JP100	LIN_Vsup1 – enables V_{SUP} for the LIN bus	
JP101	LIN_Vsup2 – enables V_{SUP} for the LIN bus	
JP102	Vsns_EN – connects battery voltage before filter to the Vsense	
JP103	LED_PW_EN – enables power supply LED	
JP104	Vcore_EN – connects V_{CORE} power supply to the daughter board connector	
JP105	Vcca_B_EN – connects base of the Q3 transistor to the VCCA_B pin	
JP106	FS0b_LED_EN – enables LED D15 for the fail-safe output no. 0	
JP109	FCCU1_EN – connects FCCU1 signal from the daughter board to the IO_3	
JP110	FCCU0_EN – connects FCCU0 signal from daughter board to the IO_2	
JP111	IO_0_PULLLD – Connects a pull-down resistor to the IO_0	
JP112	DBG_EN – enables debug mode of the MC33908	
	No jumper	Normal mode
	1 - 2	Debug mode
JP113	Vsup_EN – Power supply for MC33908.	
	Allows disconnection of all three supply pins for current measurements. Normally (no measurement), jumpers should be connected.	
	1 - 2	Enables power supply (V_{SUP}) for VSUP1 and VSUP2 pins of MC33908
	3 - 4	Enables power supply (V_{SUP}) for VSUP3 pin of MC33908
JP114	Vcore_SEL – V_{CORE} selection If this feature is used and enabled by JP7, then this resistor bridge has to be in the same configuration as the JP20. Voltage on this voltage divider has to be adjusted to the same level as for the first bridge using potentiometer POT1.	
	1 - 2	$V_{CORE} = 3.3\text{ V}$
	3 - 4	$V_{CORE} = 1.23\text{ V}$
JP115	COMP1 - Compensation network for FB_core - part 1	
	1 - 2	$V_{CORE} = 3.3\text{ V}$
	3 - 4	$V_{CORE} = 1.23\text{ V}$
JP116	BRIDGE_SEL – External resistor bridge monitoring. If this feature is used and enabled by JP7, then this resistor bridge has to be in the same config. as the JP20. Voltage on this voltage divider has to be adjusted to the same level as for the first bridge using potentiometer POT1.	
	1 - 2	$V_{CORE} = 3.3\text{ V}$
	3 - 4	$V_{CORE} = 1.23\text{ V}$
JP117	COMP2 – Compensation network for FB_core – part 2	
	1 - 2	$V_{CORE} = 3.3\text{ V}$
	3 - 4	$V_{CORE} = 1.23\text{ V}$
JP118	Gate_LS_SEL – buck-boost/standard buck mode configuration	
	1 - 2 and 3 - 4	Standard buck configuration is used (transistor disconnected from the Gate_LS pin).
	Jumpers off	Buck-boost configuration is enabled (transistor controlled by the Gate_LS pin).

Table 9. Jumper Definitions (continued)

Schematic Label	Description	
JP119	BOOTS_CORE – Configuration for BOOTS_CORE pin	
	1 - 2	For future use - BOOTS_CORE pin connected to the ground
	2 - 3	Used for MC33907_8 - BOOTS_CORE pin connected to the SW_core
JP120	Vcca_E_SEL – External transistor for V _{CCA}	
	1 - 2	Emitter of Q3 connected to VCCA_E
	2 - 3	Q102 not used
JP121	V _{CCA} /V _{AUX} regulator selection	
	1 - 2	V _{AUX} is DISABLED
	2 - 3	V _{AUX} is ENABLED
JP122	Vddio_SEL – V _{DDIO} tracking	
	1 - 2	V _{DDIO} will track V _{CCA}
	2 - 3	V _{DDIO} will track V _{CORE}
JP123	DRIFT_MONIT – External resistor bridge monitoring (for future use)	
	1 - 2	Second resistor bridge ENABLED
	2 - 3	Second resistor bridge DISABLED
JP124	IO4_SEL – IO_4 output configuration	
	1 - 2	IO_4 pulled down
	2 - 3	IO_4 connected to the LED
JP125	IO5_SEL – IO_5 output configuration	
	1 - 2	IO_5 pulled down
	2 - 3	IO_5 connected to the LED
JP126	C_OUT – selection of the output capacitance for V _{CORE} . If connected, the output capacitance is 40 µF, 20 µF otherwise.	
	No jumper	Cout = 20 µF
	1 - 2	Cout = 40 µF
JP127	Power supply for LEDs on IO_4 and IO_5	
	1 - 2	Enables power supply for IO_5
	3 - 4	Enables power supply for IO_4
JP300	POT_EN – connects potentiometer P300 to the daughter board	
JP301	PB_PULL – polarization of the pull-up/down resistor for buttons	
	1 - 2	Resistors connected to GND (pull-down resistors)
	2 - 3	Resistors connected to V _{CORE} (pull-up resistors)
JP302	PB_IN – polarization of the button output	
	1 - 2	When button is ON, output is connected to V _{CORE} .
	2 - 3	When button is ON, output is connected to the GND.
JP303	FTDI_config – supply for FTDI converter	
	1 - 2	USB converter is supplied from its internal 3,3 Power supply (standard configuration for the KIT33908MBEVBE)
	2 - 3	USB converter is supplied from the USB bus (5V)
JP304	TxD – USB/RS232 transmitter connection	
	1 - 2	MCU's transmitter will be connected to the RS232 converter
	2 - 3	MCU's transmitter will be connected to the USB converter

Table 9. Jumper Definitions (continued)

Schematic Label	Description	
JP305	RxD – USB/RS232 receiver connection	
	1 - 2	MCU's receiver will be connected to the RS232 converter
	2 - 3	MCU's receiver will be connected to the USB converter
JP306	SW_EN – enables using of switches (buttons)	
	Buttons are connected to the daughter board IOs for debug purposes.	
	1 - 2	SW1 enabled
	3 - 4	SW2 enabled
	5 - 6	SW3 enabled
	7 - 8	SW4 enabled
JP307	LED_EN – enables using of LEDs	
	LEDs are connected to the daughter board IOs for debug purposes.	
	1 - 2	LED1 enabled
	3 - 4	LED2 enabled
	5 - 6	LED3 enabled
7 - 8	LED4 enabled	

11 Power Supply Scheme when Using Daughterboard MPC5643L

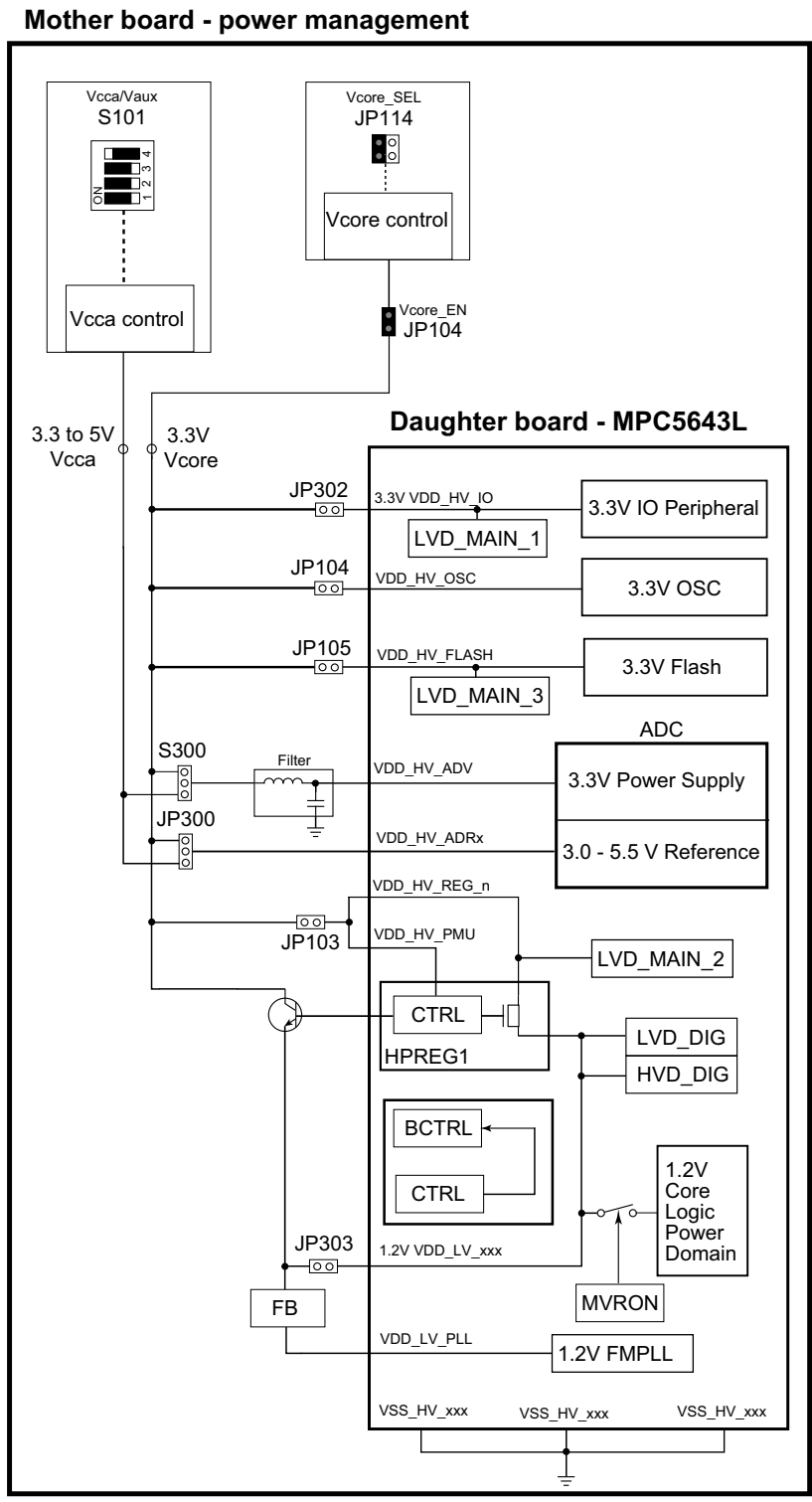

Figure 11. MPC5643L Power Supply Scheme

12 Schematic

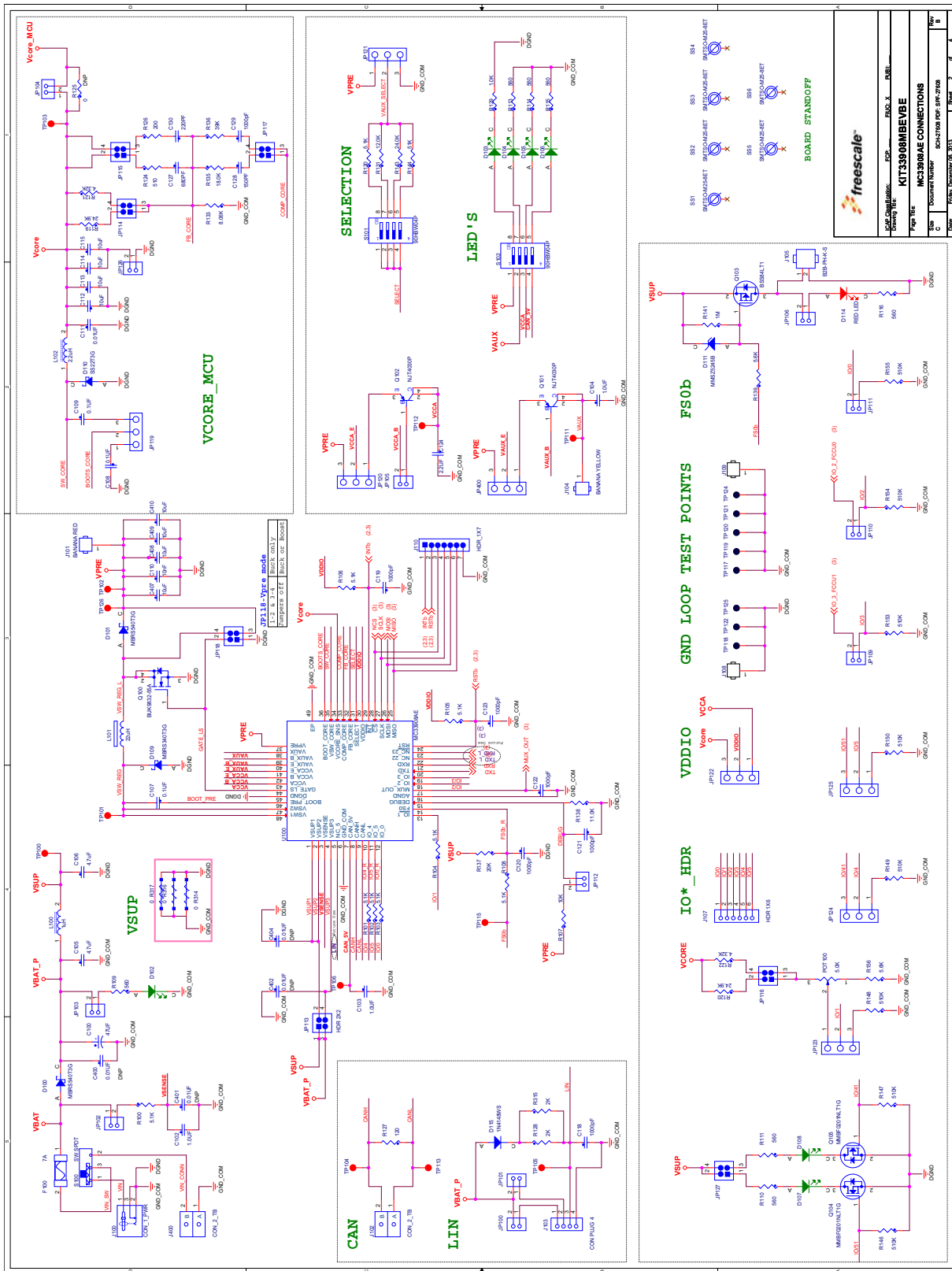
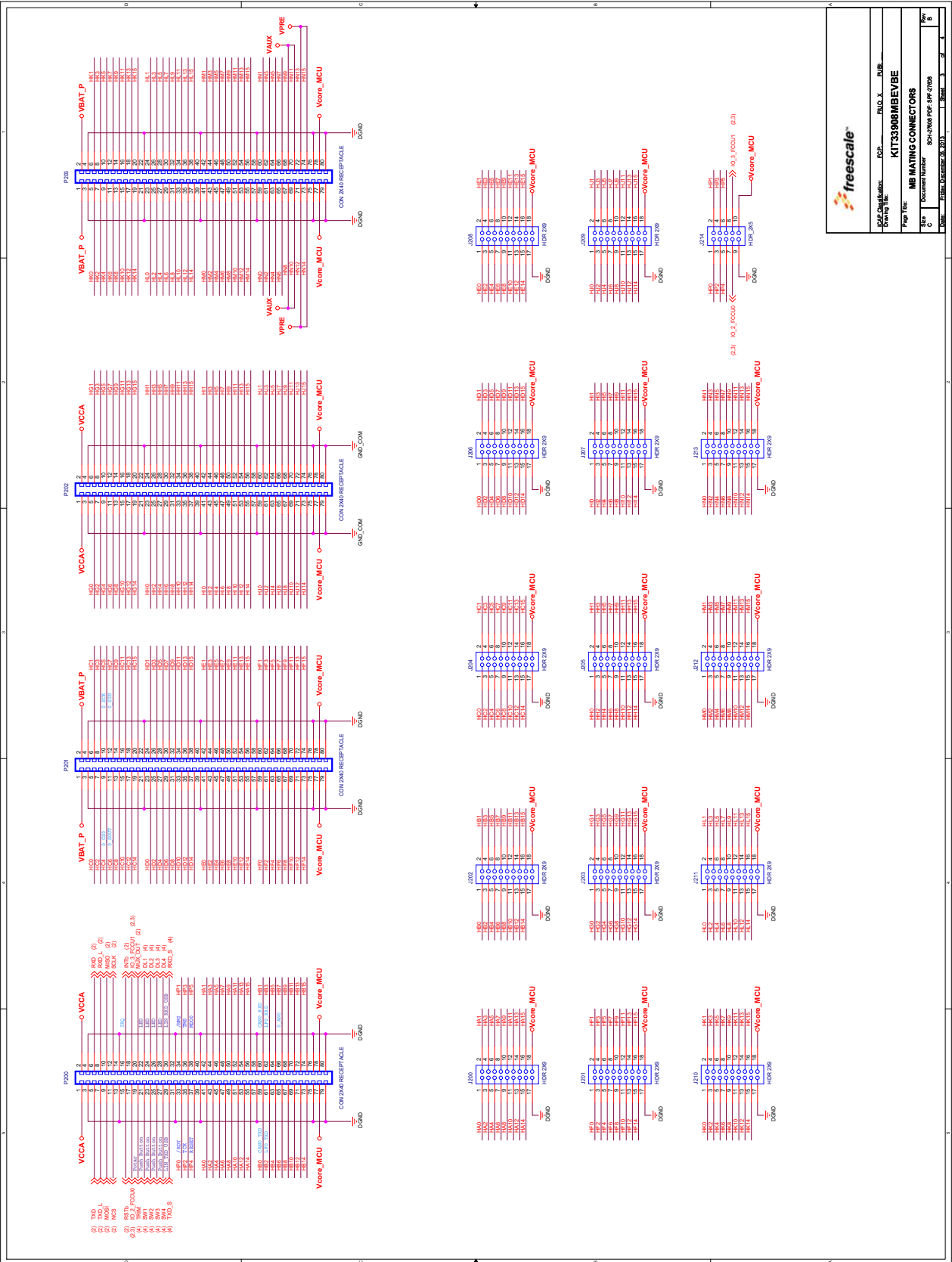

Figure 12. Evaluation Board Schematic, Part 1



freescale

Doc ID: 6258
 Rev: 1.0
 Date: 2014-03-20
 Page 1 of 1
 Document Number: SCH-2300 PDF-2300
 Doc ID: 6258 Rev: 1.0 Date: 2014-03-20 Page 1 of 1

Figure 13. Evaluation Board Schematic, Part 2

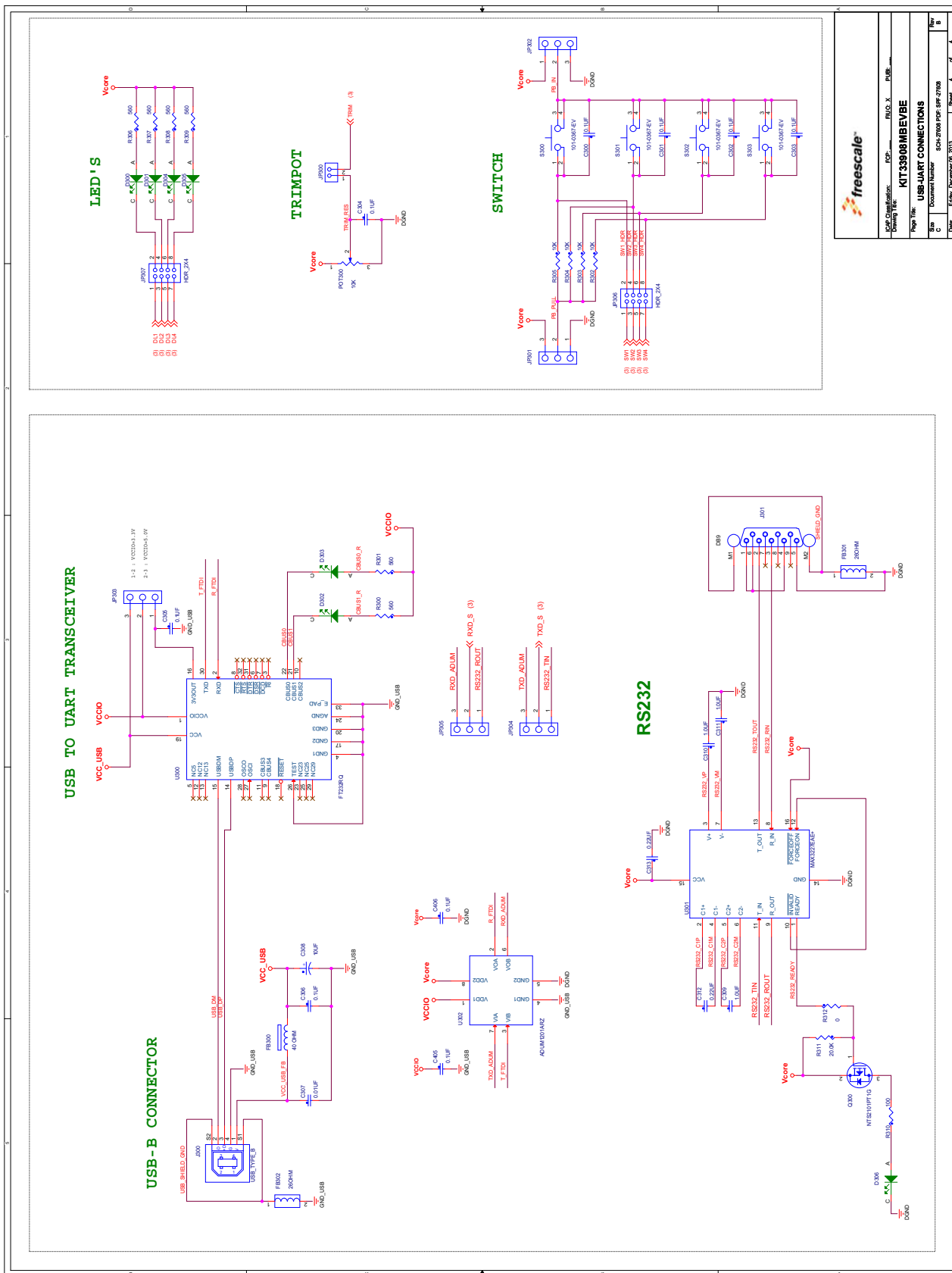

Schematic Drawing Title:	Rev: 1.0 Date:
KIT33908MBEVB USB-UART CONNECTIONS	
Page No:	
Document Number:	
Rev:	Date:
1 2 3 4 5	1 2 3 4 5

Figure 14. Evaluation Board Schematic, Part 3

13 Board Layout

13.1 Assembly Layer Top

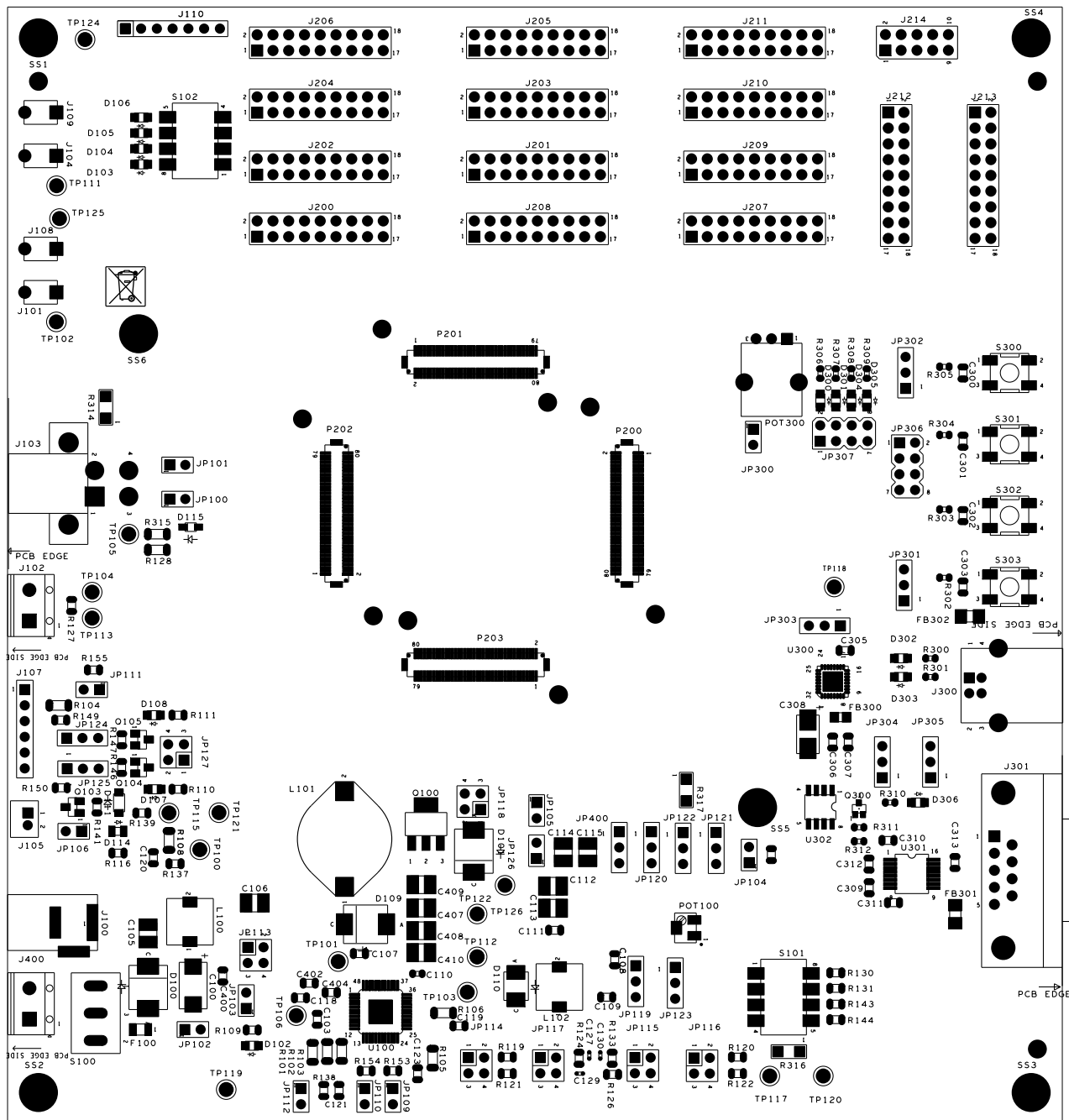
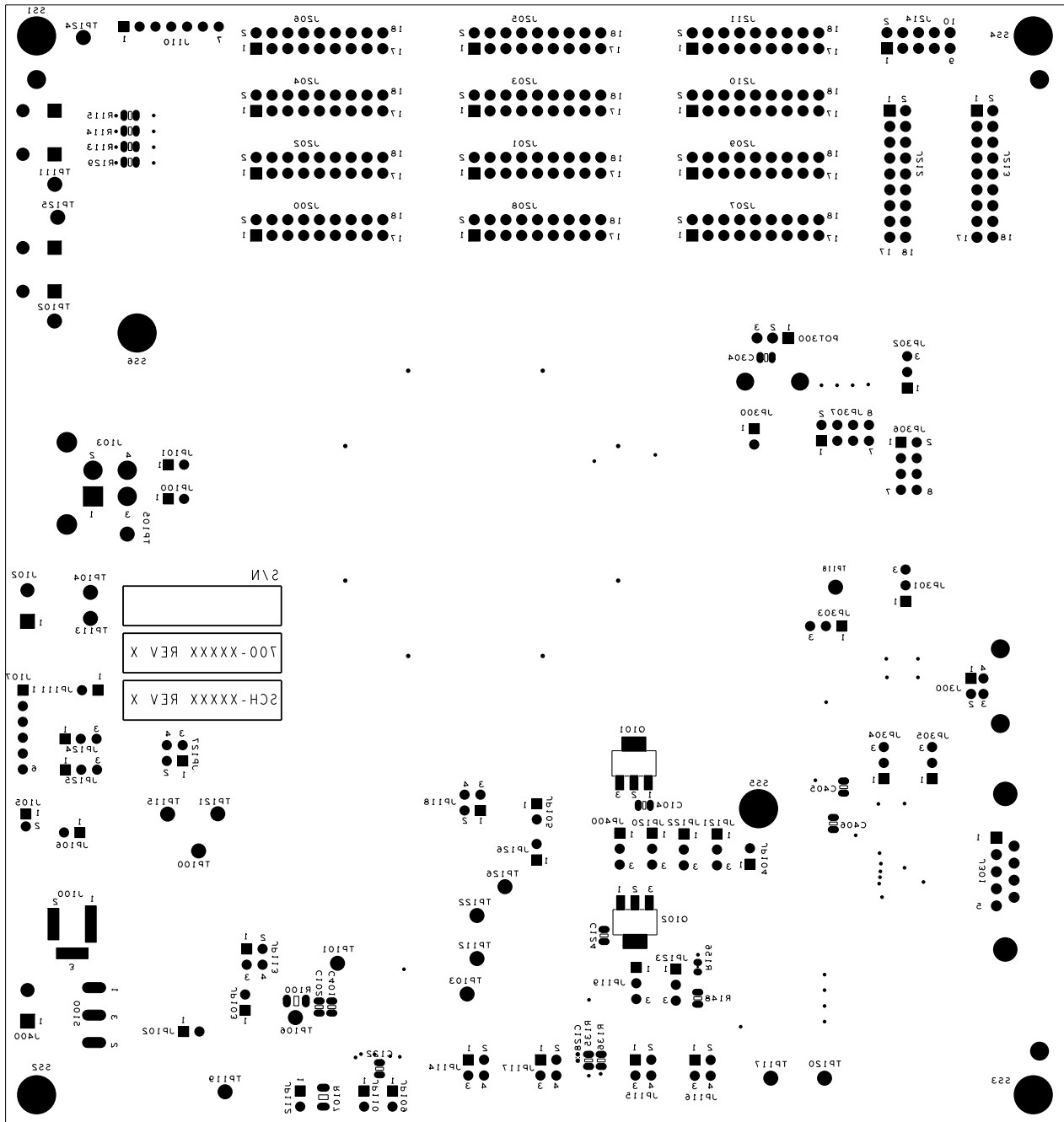
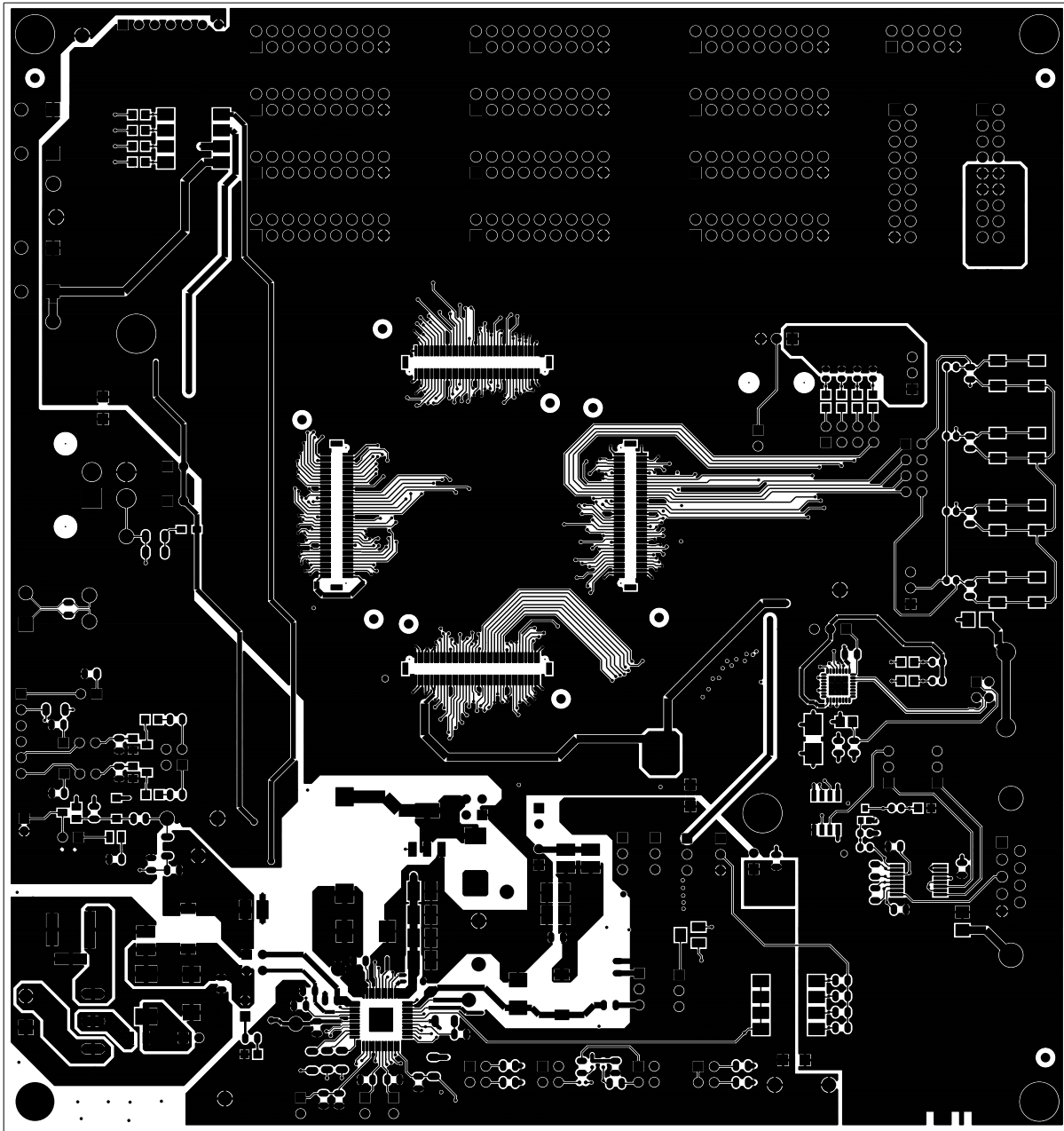

Figure 15. Silk Screen 1 for Top Component Placement

13.2 Assembly Layer Bottom



13.3 Top Layer



13.4 First Internal Ground Plane

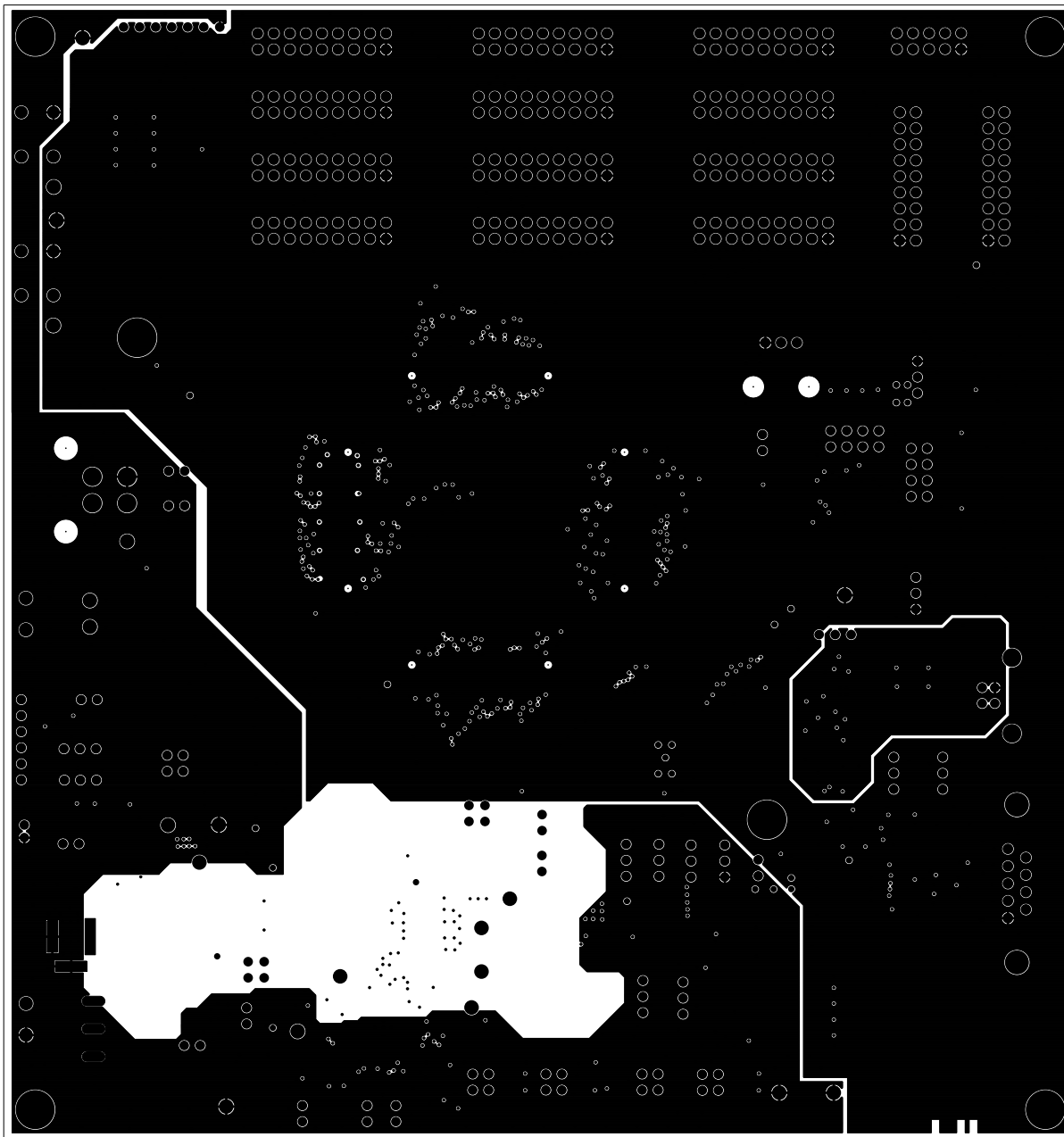

13.5 First Internal Signal Plane

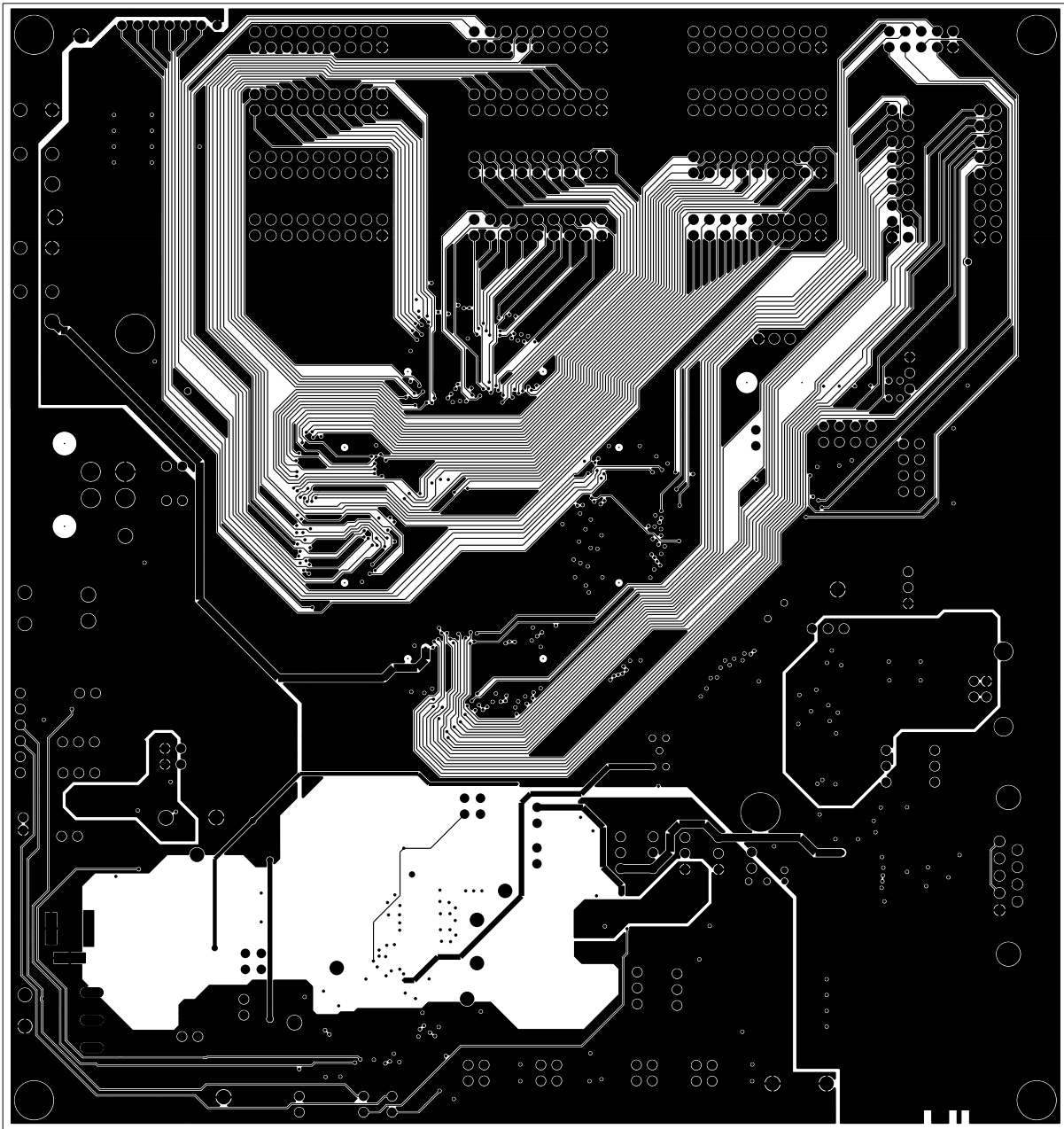

13.6 Second Internal Signal Plane

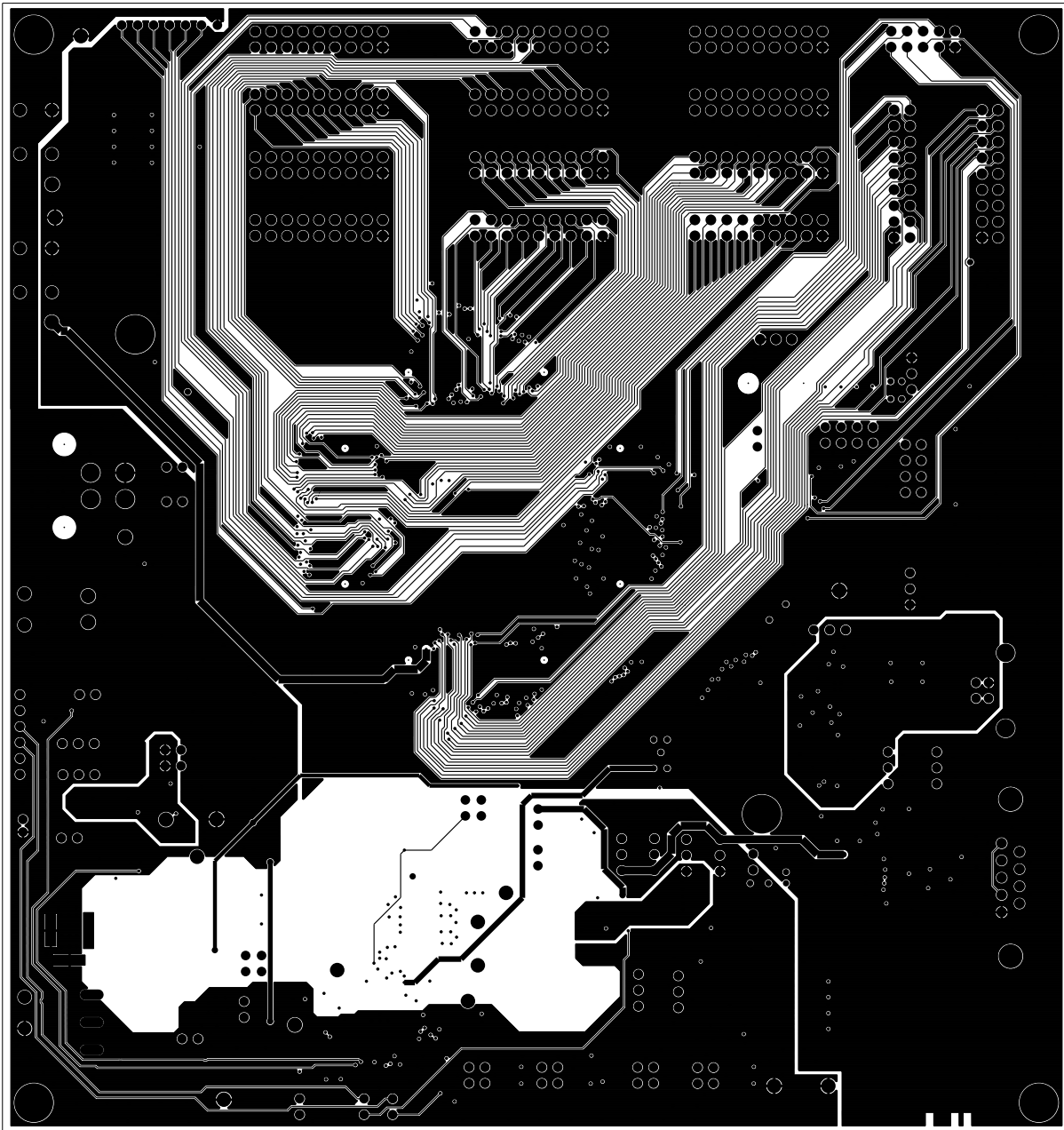

13.7 Second Internal Ground Plane

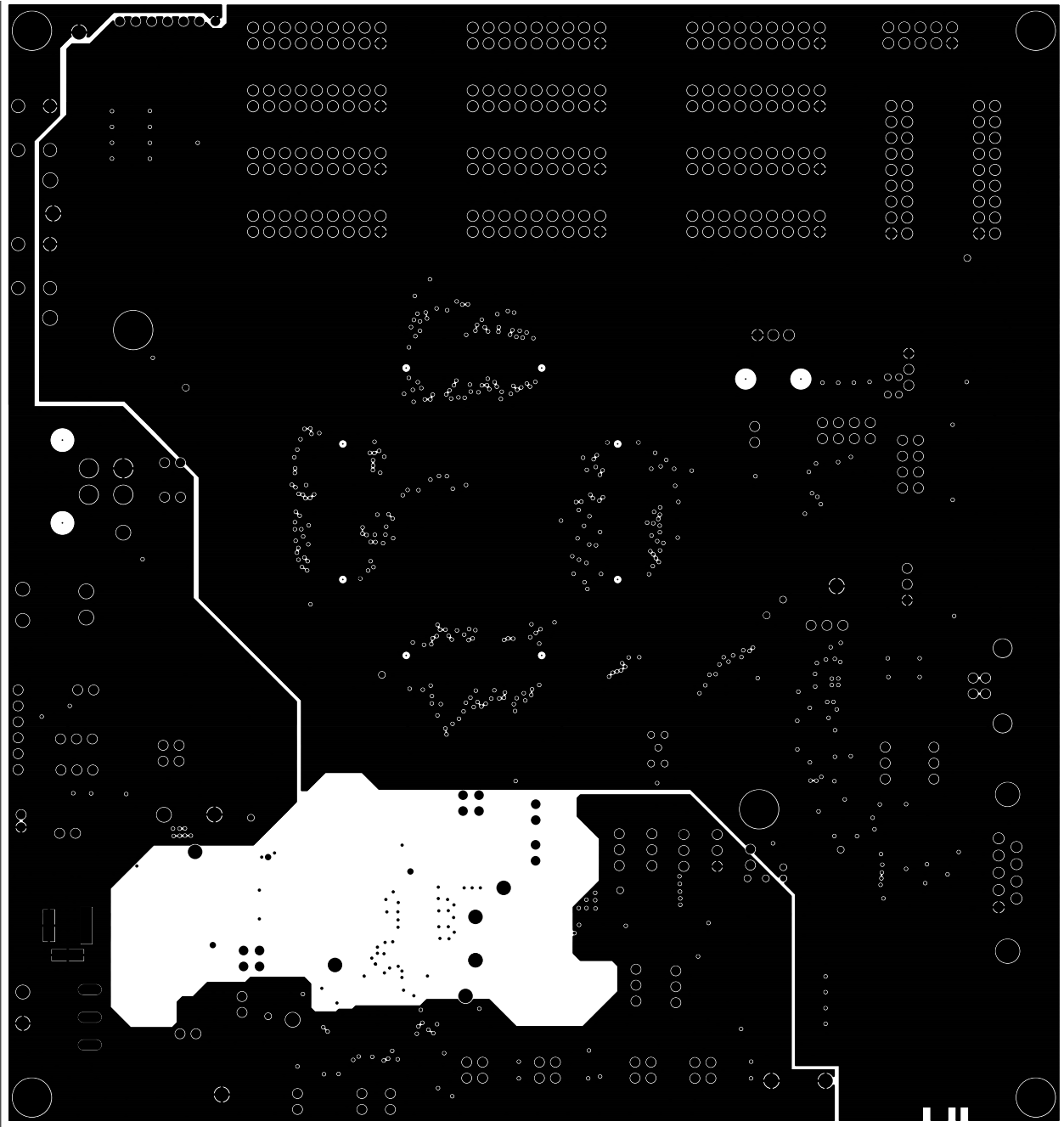

13.8 Bottom Layer

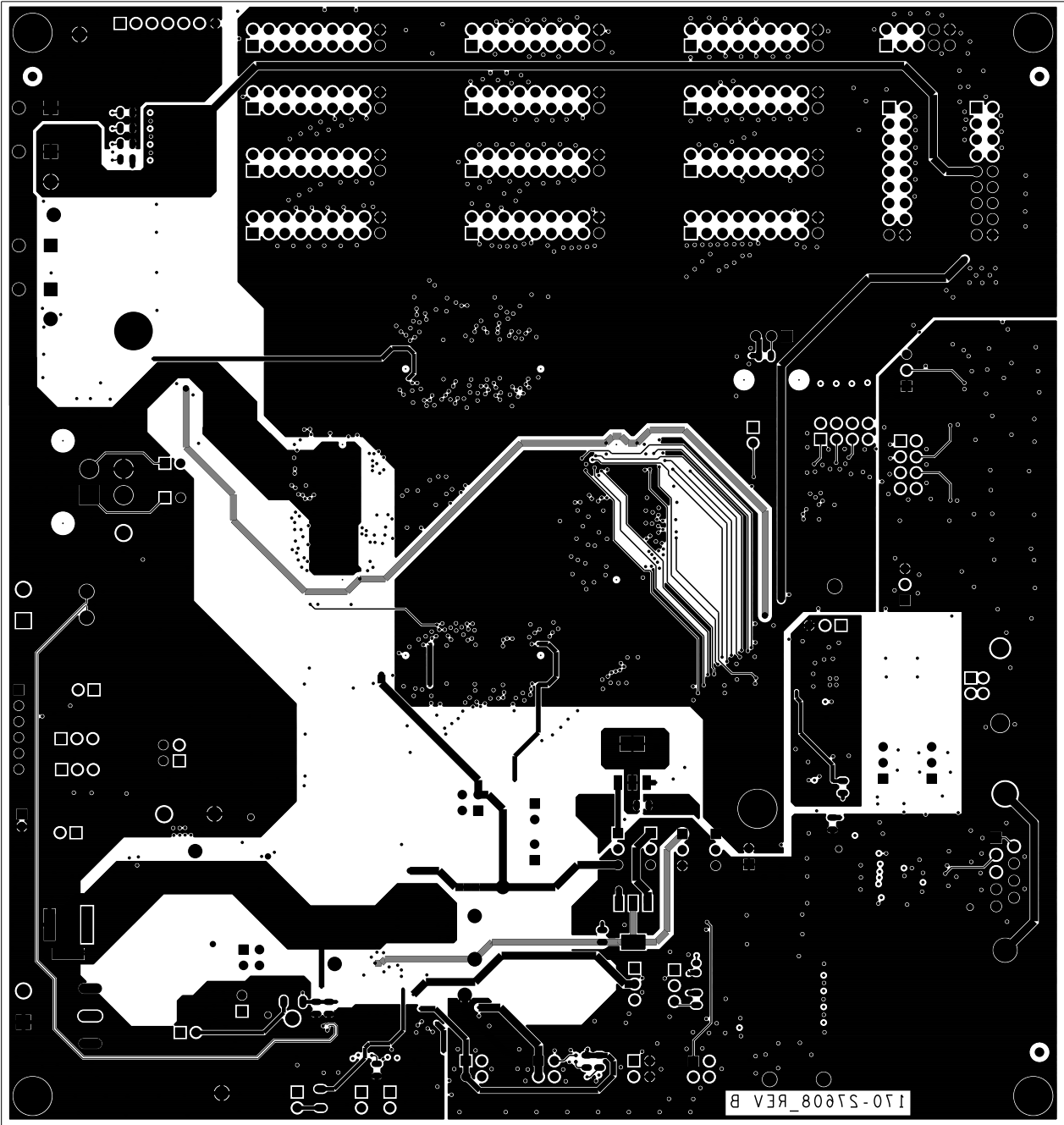

14 Bill of Materials

Table 10. Bill of Materials ⁽²⁾

Item	Qty	Schematic Label	Value	Manufacturer	Part Number	Assy Opt
1	1	C100	47 μ F	VISHAY Intertechnology	293D476X9016D2TE3	
2	6	C102 - C104, C309 - C311	1.0 μ F	AVX	08053C105KAT2A	
3	2	C105, C106	4.7 μ F	Murata	GCM32ER71H475KA55L	
4	3	C107 - C109	0.1 μ F	KEMET	C0805C104J5RACTU	
5	1	C110	10 nF	AVX	06035C103JAT2A	
6	2	C111, C307	0.01 μ F	VENKEL Company	C0805X7R250-103KNE	
7	8	C112 - C115, C407 - C410	10 μ F	Murata	GCM32ER71E106KA57	(4)
8	6	C118 - C123	1000 pF	AVX	08055C102KAT2A	
9	1	C124	2.2 μ F	AVX	08053C225KAT2A	
10	1	C127	680 pF	KEMET	C0402C681J5RACTU	
11	1	C128	150 pF	MURATA	GRM1555C1H151JA01B	
12	1	C129	1000 pF	MURATA	GRM1555C1H102JA01D	
13	1	C130	220 pF	KEMET	C0402C221J5GAC	
14	9	C300 - C306, C405, C406	0.1 μ F	Murata	GRM21BR71E104KA01L	
15	1	C308	10 μ F	AVX	TPSC106K016R0500	
16	2	C312, C313	0.22 μ F	AVX	08053C224KAT2A	
17	4	C400 - C402, C404	0.01 μ F	VENKEL Company	C0805X7R250-103KNE	(3)
18	2	D100, D101		ON Semiconductor	MBRS540T3G	(4)
19	14	D102 - D108, D300 - D306		LUMEX	SML-LXT0805GW-TR	
20	1	D109		ON Semiconductor	MBRS340T3G	(4)
21	1	D110		ON Semiconductor	SS22T3G	
22	1	D111		On Semiconductor	MMSZ5245BT1G	
23	1	D114		LUMEX	RED LED SML-LXT0805IW-TR	
24	1	D115		DIODES INC	1N4148WS-7-F	
25	1	F100	7.0 A	LITTELFUSE	0440007.WR	
26	1	FB300	40 Ohm	STEWART	MI0805K400R-10	
27	2	FB301, FB302	26 Ohm	LAIRD Technologies	MI1206K260R-10	
28	1	J100		CUI STACK	CON_1_PWR PJ-002BH	
29	1	J101		Emerson Network Power Connectivity Solutions, Inc	Banana Red 105-1102-001	
30	2	J102, J400		CAMDEN Electronics LTD	CON_2_TB CTB5000/2	
31	1	J103		Molex	CON PLUG 4 39295043	
32	1	J104		Emerson Network Power Connectivity Solutions, Inc	Banana Yellow 105-1107-001	
33	1	J105		JST MFG. CO	B2B-PH-K-S(LF)(SN)	
34	1	J107		SAMTEC	HDR 1X6 TSW-106-07-S-S	
35	2	J108, J109		Emerson Network Power Connectivity Solutions, Inc	Banana Black 105-1103-001	
36	1	J110		SAMTEC	HDR_1X7 TSW-107-07-G-S	
37	14	J200 - J213		SAMTEC	HDR 2X9 TSW-109-07-S-D	
38	1	J214		TYCO Electronics	HDR_2X5 826632-5	
39	1	J300		LUMBERG INC	USB_TYPE_B 241103	

Table 10. Bill of Materials ⁽²⁾ (continued)

Item	Qty	Schematic Label	Value	Manufacturer	Part Number	Assy Opt
40	1	J301		TYCO Electronics	DB9 5747844-6	
41	13	JP100 - JP106, JP109 - JP112, JP126, JP300		SAMTEC	TSW-102-08-G-S	
42	7	JP113 - JP118, JP127		Samtec	HDR 2X2 TSW-102-07-G-D	
43	13	JP119 - JP125, JP301 - JP305, JP400		TYCO Electronics	HDR_1X3 826629-3	
44	2	JP306, JP307		Samtec	HDR_2X4 TSW-104-07-S-D	
45	1	L100	1.0 μ H	Epcos	B82472G4102M000	(4)
46	1	L101	22 μ H	Epcos	B82479G1223M000	(4)
47	1	L102	2.2 μ H	Epcos	B82472G6222M000	
48	4	P200 - P203		Hirose	CON 2X40 Receptacle DF12(3.0)-80DS-0.5V(86)	
49	1	POT100	5.0 K	Bourns	3224W-1-502E	
50	1	POT300	10 K	ALPS Electric (USA) INC.	RK09K1130AP5	
51	1	Q100		NXP Semiconductors	BUK9832-55A,115	(4)
52	2	Q101, Q102		ON Semiconductor	NJT4030PT3G	(4)
53	1	Q103		ON Semiconductor	BSS84LT1G	
54	2	Q104, Q105		ON Semiconductor	MMBF0201NLT1G	
55	1	Q300		ON Semiconductor	NTS2101PT1G	
56	8	R100 - R106, R108	5.1 K	ROHM	MCR18EZJ512	
57	1	R107	10 K	Vishay Intertechnology	CRCW120610K0FKEA	
58	7	R109 - R111, R113 - R116	560	KOA Speer	RK73B2ATTD561J	
59	2	R119, R120	24.9 K	Yageo America	RC0805FR-0724K9L	
60	2	R121, R122	4.32 K	Panasonic	ERJ-6ENF4321V	
61	1	R124	510	SMEC	RC73A2A5100FTF	
62	1	R125	0.0	Yageo America	RC0805JR-070RL	(3)
63	1	R126	200	Bourns	CR0805FX2000ELF	
64	1	R127	120	Rohm	MCR10EZPF1200	
65	2	R128, R315	2.0 K	Yageo	RC1206JR-072KL	
66	1	R129	1.0 K	KOA Speer	RK73H2ATTD1001F	
67	1	R130	5.1 K	Yageo America	RC0805FR-075K1L	
68	1	R131	12.0 K	Bourns	CR0805-FX-1202ELF	
69	1	R133	8.06 K	Panasonic	ERJ-6ENF8061V	
70	1	R135	18 K	KOA Speer	RK73H2ATTD1802F	
71	1	R136	39 K	Vishay Intertechnology	CRCW080539K0FKEA	
72	1	R137	20 K	Venkel Company	CR0805-8W-2002FT	
73	1	R138	11 K	KOA Speer	RK73H2ATTD1102F	
74	1	R139	5.6 K	Yageo America	RC0805FR-075K6L	
75	1	R141	1.0 M	SMEC	RC73L2A105JTF	
76	1	R143	24 K	Panasonic	ERJ-6GEYJ243V	
77	1	R144	51 K	KOA Speer	RK73B2ATTD513J	
78	8	R146 - R150, R153 - R155	510 K	Bourns	CR0805-JW-514ELF	
79	1	R156	5.6 K	KOA Speer	RK73H1JTDD5601F	
80	2	R300, R301	560	KOA Speer	RK73H1JTDD5600F	
81	4	R302 - R305	10 K	KOA Speer	RK73B1JTDD103J	
82	4	R306 - R309	560	KOA Speer	RK73B1JTDD561J	

Table 10. Bill of Materials ⁽²⁾ (continued)

Item	Qty	Schematic Label	Value	Manufacturer	Part Number	Assy Opt
83	1	R310	100	KOA Speer	RK73H1JTTD1000F	
84	1	R311	20.0 K	KOA Speer	RK73H1JTTD2002F	
85	1	R312	0.0	Vishay Intertechnology	CRCW06030000Z0EA	
86	3	R314, R316, R317	0.0			
87	1	S100		ALPS Electric (USA) INC.	SW SPDT SDKTA20100	
88	2	S101,S102		Grayhill	90HBW04PT	
89	4	S300 - S303		Mountain	101-0367-EV	
90	6	SS1 - SS6		PEM Fasteners	SMTSO-M25-8ET	
91	12	TP100 - TP106, TP111 - TP113, TP115, TP126		Keystone Electronics	Testloop_Red 5010	
92	8	TP117 - TP122, TP124, TP125		Keystone Electronics	Testloop_Black 5011	
93	1	U100		Freescale Semiconductor	MC33908AE	(4)
94	1	U300		Future Technology Devices International LTD.	FT232RQ	
95	1	U301		MAXIM	MAX3227EAE+	
96	1	U302		Analog Devices	ADUM1201ARZ	

Notes

2. Freescale does not assume liability, endorse, or warrant components from external manufacturers that are referenced in circuit drawings or tables. While Freescale offers component recommendations in this configuration, it is the customer's responsibility to validate their application.
3. Do not populate
4. **Critical components.** For critical components, it is vital to use the manufacturer listed.

15 References

Following are URLs where you can obtain information on related Freescale products and application solutions:

Freescale.com Support Pages	URL
MC33908 Product Summary Page	http://www.freescale.com/webapp/sps/site/prod_summary.jsp?code=MC33908
KIT33908MBEVBE Tool Summary Page	http://www.freescale.com/webapp/sps/site/prod_summary.jsp?code=KIT33908MBEVBE
KITMPC5643DBEVM Tool Summary Page	http://cache.freescale.com/files/analog/prod_summary.jsp?code=KITMPC5643DBEVM
KIT908-5643EVM Tool Summary Page	http://cache.freescale.com/files/analog/doc/prod_summary.jsp?code=KIT908-5643EVM
Analog Home Page	http://www.freescale.com/analog
Automotive Home Page	http://www.freescale.com/automotive

15.1 Support

Visit www.freescale.com/support for a list of phone numbers within your region.

15.2 Warranty

Visit www.freescale.com/warranty for a list of phone numbers within your region.

16 Revision History

Revision	Date	Description of Changes
1.0	3/2014	Initial Release



How to Reach Us:

Home Page:
freescale.com

Web Support:
freescale.com/support

Information in this document is provided solely to enable system and software implementers to use Freescale products. There are no express or implied copyright licenses granted hereunder to design or fabricate any integrated circuits based on the information in this document.

Freescale reserves the right to make changes without further notice to any products herein. Freescale makes no warranty, representation, or guarantee regarding the suitability of its products for any particular purpose, nor does Freescale assume any liability arising out of the application or use of any product or circuit, and specifically disclaims any and all liability, including without limitation consequential or incidental damages. "Typical" parameters that may be provided in Freescale data sheets and/or specifications can and do vary in different applications, and actual performance may vary over time. All operating parameters, including "typicals," must be validated for each customer application by customer's technical experts. Freescale does not convey any license under its patent rights nor the rights of others. Freescale sells products pursuant to standard terms and conditions of sale, which can be found at the following address: freescale.com/SalesTermsandConditions.

Freescale, the Freescale logo, the Energy Efficient Solutions logo are trademarks of Freescale Semiconductor, Inc., Reg. U.S. Pat. & Tm. Off. SafeAssure and SMARTMOS are trademarks of Freescale Semiconductor, Inc. All other product or service names are the property of their respective owners.

© 2014 Freescale Semiconductor, Inc.

Document Number: KT33908MBUG
Rev. 1.0
3/2014



X-ON Electronics

Largest Supplier of Electrical and Electronic Components

Click to view similar products for [Power Management IC Development Tools](#) category:

Click to view products by [NXP](#) manufacturer:

Other Similar products are found below :

[EVAL-ADM1168LQEBZ](#) [EVB-EP5348UI](#) [MIC23451-AAAYFL EV](#) [MIC5281YMME EV](#) [DA9063-EVAL](#) [ADP122-3.3-EVALZ](#) [ADP130-0.8-EVALZ](#) [ADP130-1.2-EVALZ](#) [ADP130-1.5-EVALZ](#) [ADP130-1.8-EVALZ](#) [ADP1712-3.3-EVALZ](#) [ADP1714-3.3-EVALZ](#) [ADP1715-3.3-EVALZ](#) [ADP1716-2.5-EVALZ](#) [ADP1740-1.5-EVALZ](#) [ADP1752-1.5-EVALZ](#) [ADP1828LC-EVALZ](#) [ADP1870-0.3-EVALZ](#) [ADP1871-0.6-EVALZ](#) [ADP1873-0.6-EVALZ](#) [ADP1874-0.3-EVALZ](#) [ADP1882-1.0-EVALZ](#) [ADP199CB-EVALZ](#) [ADP2102-1.25-EVALZ](#) [ADP2102-1.875EVALZ](#) [ADP2102-1.8-EVALZ](#) [ADP2102-2-EVALZ](#) [ADP2102-3-EVALZ](#) [ADP2102-4-EVALZ](#) [ADP2106-1.8-EVALZ](#) [ADP2147CB-110EVALZ](#) [AS3606-DB](#) [BQ24010EVM](#) [BQ24075TEVM](#) [BQ24155EVM](#) [BQ24157EVM-697](#) [BQ24160EVM-742](#) [BQ24296MEVM-655](#) [BQ25010EVM](#) [BQ3055EVM](#) [NCV891330PD50GEVB](#) [ISLUSBI2CKIT1Z](#) [LM2744EVAL](#) [LM2854EVAL](#) [LM3658SD-AEV/NOPB](#) [LM3658SDEV/NOPB](#) [LM3691TL-1.8EV/NOPB](#) [LM4510SDEV/NOPB](#) [LM5033SD-EVAL](#) [LP38512TS-1.8EV](#)