



32-bit Controller Solutions

Vybrid VF5xxR Family

Automotive solutions for connected radio, entry-level infotainment and digital instrument cluster applications



Overview

The Vybrid VF5xxR family is purpose-built and cost-optimized for connected radio, entry-level infotainment and digital instrument cluster applications. The family features generous 1.5 MB on-chip SRAM, dual-core architecture combining the high-performance low-power ARM® Cortex®-A5 application processor with the ultra-low-power ARM Cortex®-M4 microcontroller, OpenVG graphics accelerator, 2D graphics composition engine and dual QuadSPI interface with DDR support. Standard vehicle connectivity is provided through integrated CAN controllers, MLB, UART/LIN and Ethernet with IEEE® 1588 support. The integrated video ADC allows for direct connection to analog cameras without the need for expensive external circuits. Dual USB 2.0 OTG controllers (with integrated PHY) and a large variety of serial interfaces such as UART, SPI, and I²S provide connectivity to consumer electronic devices such as smartphones, tablets and Bluetooth® enabled devices. The VF5xxR family is software

Target Applications

- Connected radios
- Entry-level infotainment
- Digital instrument clusters

Vybrid VF5xxR Block Diagram

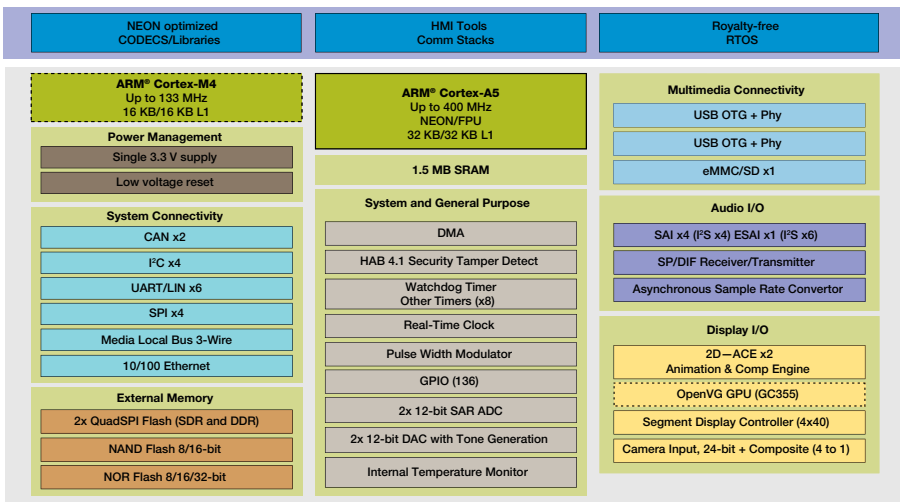

Optional



compatible with the VF3xxR family, providing scalability from low-cost basic connected radios without external DRAM up to entry-level infotainment systems using GPU-accelerated dual displays with compelling user interfaces.

Enablement Software

Vybrid automotive families include software for connected radio and cluster applications. Built upon auto-grade BSPs for MQX™, our software is the ideal starting point for your radio and cluster designs. The enablement components are included with every chip we sell, and provide a full working system complete with BSP, middleware and example applications. Our software solution is highly configurable and architected with Vybrid families in mind, scaling from low-cost solutions that use the internal SRAM only, up to feature-rich, graphics-intensive solutions.

Development Tools

EVB-VF522R3

Evaluation platform for cost optimized automotive connected radio and infotainment systems.

Industry-Leading Partners

In addition to the enablement components, we have teamed up with select industry-leading partners that have rich automotive heritage and embedded systems know-how to provide third-party components for areas like Bluetooth, HMI tools and acoustic echo cancellation/noise suppression. These include:

Altia Design with DeepScreen

Altia's suite of user interface engineering tools offers a concept-to-code solution for getting best-in-class user interfaces for Vybrid product families.

OpenSynergy Blue SDK

Provides an efficient way to add reliable Bluetooth radio communications to any embedded device.

Cybercom blueGO

A robust and portable multi-profile Bluetooth software application framework for advanced hands-free functionality in automotive IVI systems. blueGO minimizes the Bluetooth application development effort and is subject to continuous IOP testing.

Alango Voice

Communication Package

A suite of front-end digital signal processing technologies enabling high quality voice communication specifically optimized for small footprint embedded applications such as connected radio hands-free on Vybrid's production software platform.

Advanced Connected Radio System Diagram

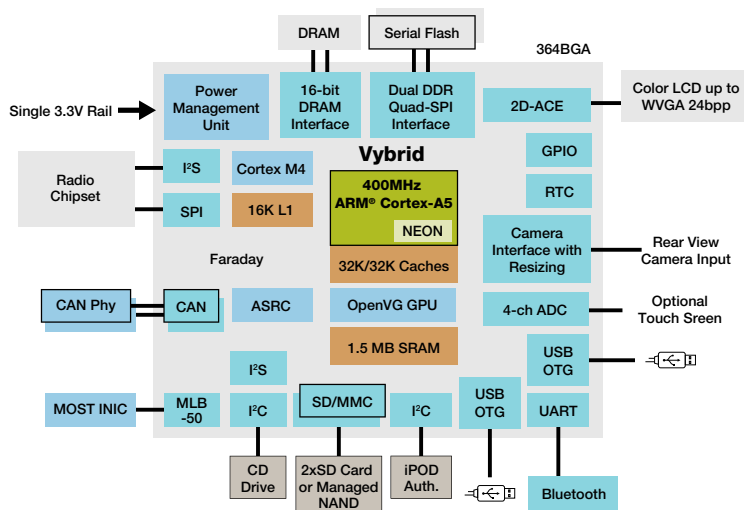

Key Features for the VF5xxR

CPU	400 MHz ARM® Cortex®-A5, 167 MHz ARM Cortex®-M4
On-chip memory	1.5 MB (512 KB ECC) or 1 MB and 512 KB L2 cache
Serial flash interface	2x QuadSPI Flash with DDR support
NAND	16-bit up to 32-bit HW ECC
FlexBus interface (parallel NOR)	Yes (address/data mux'd plus 8-bit dedicated data)
Display interface	TFT and 40 x 4 segmented LCD or 2x TFT up to WVGA
Video ADC/camera Input	4x composite 24-bit parallel
Ethernet	2x 10/100 Ethernet with IEEE® 1588
Analog-to-Digital Converter	10-channel, 12-bit ADC
USB	2x USB OTG HS
Audio interface	SAI x4 (I²s x4) and ESAI x1 (2 TX, 4 TX OR RX)
UART, DSPI, I²C	6, 4, 4
SD/MMC interface	2
CAN	2x FlexCAN
MOST	1x MLB50
GPIO	Up to 136
Package	364-pin MAPBGA, 17x17 mm², 0.8 mm pitch

For more information, visit freescale.com/Vybrid

Freescale and the Freescale logo are trademarks of Freescale Semiconductor, Inc., Reg. U.S. Pat. & Tm. Off. Vybrid is a trademark of Freescale Semiconductor, Inc. ARM is a registered trademark of ARM Limited. ARM Cortex-A5 and ARM Cortex-M4 are trademarks of ARM Limited. All other product or service names are the property of their respective owners.
© 2012, 2014 Freescale Semiconductor, Inc.



X-ON Electronics

Largest Supplier of Electrical and Electronic Components

Click to view similar products for [Display Modules](#) category:

Click to view products by [NXP](#) manufacturer:

Other Similar products are found below :

[P6153-PR](#) [TDP0700T800480PCAP](#) [P6171DPR-DC-RS](#) [P6171DPR-DC-U](#) [MIKROMEDIA 4 FOR STM32F4 CAPACITIVE FPI](#)
[MIKROMEDIA 3 FOR STM32F4 CAPACITIVE FPI](#) [TN0216ANVNANN-GN00](#) [TN0104ANVAANN-GN00](#) [TN0181ANVNANN-GN00](#)
[MIKROMEDIA 5 FOR TIVA CAPACITIVE](#) [MIKROMEDIA 4 FOR TIVA CAPACITIVE](#) [MIKROMEDIA 4 FOR PIC32MZ CAPACITIVE](#)
[RVT43ULFNWC03 V4](#) [SM-RVT101HVBFWCA0](#) [SM-RVT101HVBNWCA0](#) [SM-RVT35HHBFWCA0](#) [SM-RVT35HHBNWCA0](#) [SM-](#)
[RVT43HLBNWCA0](#) [SM-RVT50HQBFWCA0](#) [SM-RVT50HQBNWCA0](#) [SM-RVT70HSBFWCA0](#) [SM-RVT70HSBNWCA0](#) [11769](#)
[MIKROMEDIA FOR DSPIC33](#) [MIKROMEDIA FOR PIC24](#) [MIKROMEDIA FOR PIC32](#) [MIKROMEDIA FOR STELLARIS M3](#)
[MIKROMEDIA HMI 3.5 RES](#) [MIKROMEDIA HMI 5](#) [MIKROMEDIA PLUS FOR FT90X](#) [MIKROMEDIA PLUS FOR PIC32MX7 SHIELD](#)
[MIKROMEDIA PROTO SHIELD](#) [MIKROMEDIA 5 FOR TIVA](#) [MIKROMEDIA 5 FOR TIVA SHIELD](#) [MIKROMEDIA 7 FOR STM32F4](#)
[MIKROMEDIA CONNECT SHIELD](#) [MIKROMEDIA FOR ARM](#) [MIKROMEDIA FOR PSOC5LP](#) [MIKROMEDIA GAMING SHIELD](#)
[MIKROMEDIA HMI 4.3 UXB](#) [MIKROMEDIA HMI 5 RES](#) [MIKROMEDIA HMI 5 UXB](#) [MIKROMEDIA HMI 7](#) [MIKROMEDIA HMI](#)
[BREAKOUT BOARD](#) [RVT70AQFNWC00](#) [18207](#) [PIS-0260](#) [GEN4-ULCD-50D-PI](#) [GEN4-ULCD-70D](#) [GEN4-ULCD-70D-PI](#)