

Dual DSI master transceiver

The 33SA0528 is a third generation SMARTMOS standalone, dual-channel distributed system interface (DSI) master device.

Each of the two independent channels contain a differential driver and a dual adder receiver. The embedded DSI protocol engine converts the DSI data between the physical interface and the two redundant SPI interfaces. The MCU can control and configure the 33SA0528 and extract all of the slaves transceivers data from it via the dual SPI.

To ensure the communication reliability, the 33SA0528 uses an on-chip band gap reference regulator to monitor all of the supply voltages, and uses an on-chip oscillator to monitor the PLL clock for the external clock error detection.

Features

- Two independent DSI master channels
- Supports command and response mode for slave configuration
- Supports periodic data collection mode (PDCM) for periodic slave data transfers
- Supports discovery mode for slave physical address self-programming
- 10 MHz 32-bit dual SPI: main SPI for device configuration and DSI operation, and redundant SPI for safety purposes
- Point-to-point, parallel, daisy chain bus topologies
- Various diagnostic features

33SA0528

Automotive restraint system



AC SUFFIX (PB-FREE)
98ASH70029A
32-PIN LQFP

Applications

- Automotive airbag and safety
- Industrial systems
- Sense and trigger applications

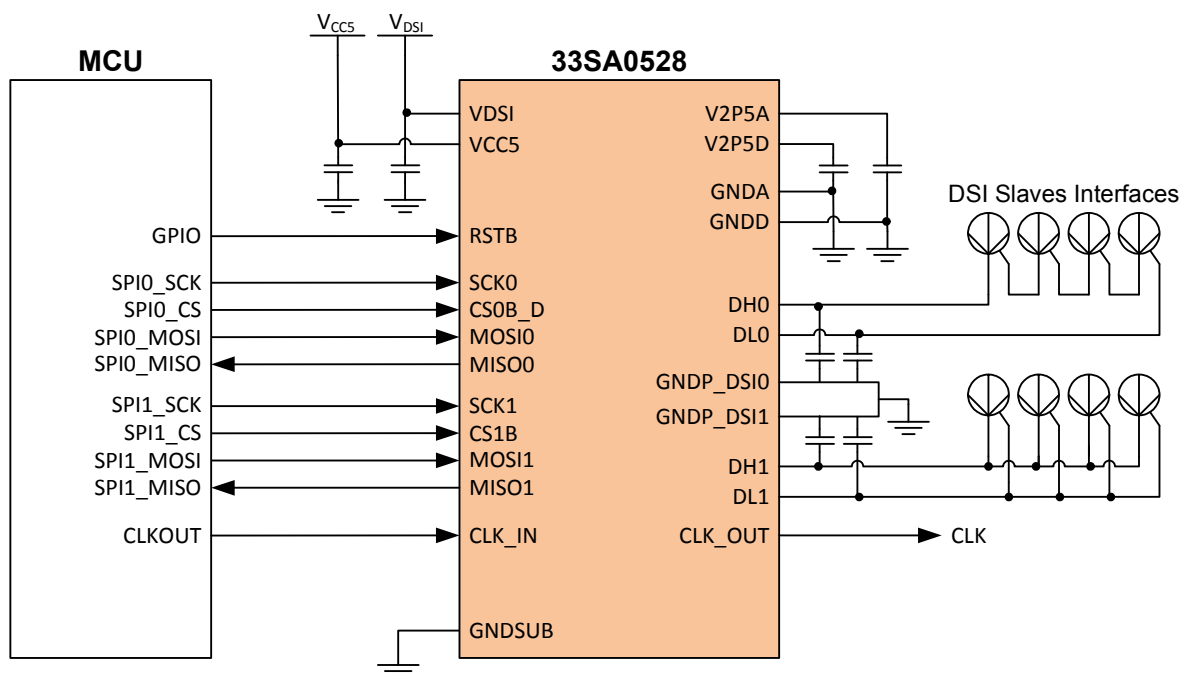

Figure 1. 33SA0528 simplified application diagram

* This document contains certain information on a new product. Specifications and information herein are subject to change without notice.

Table of Contents

| | | |
|-----|-----------------------------------|----|
| 1 | Orderable parts | 3 |
| 2 | Internal block diagram | 4 |
| 3 | Pin connections | 5 |
| 3.1 | Pinout diagram | 5 |
| 3.2 | Pin definitions | 5 |
| 4 | General product characteristics | 7 |
| 4.1 | Maximum ratings | 7 |
| 4.2 | Thermal characteristics | 7 |
| 4.3 | Operating conditions | 8 |
| 4.4 | Supply currents | 8 |
| 5 | General IC functional description | 9 |
| 5.1 | Block diagram | 9 |
| 5.2 | Features | 9 |
| 5.3 | Functional description | 9 |
| 5.4 | Communication | 9 |
| 6 | Functional block description | 10 |
| 6.1 | SPI | 10 |
| 6.2 | DSI protocol engine | 20 |
| 6.4 | Power supply monitor | 30 |
| 6.5 | Clock and reset module | 31 |
| 7 | Typical applications | 33 |
| 7.1 | Introduction | 33 |
| 7.2 | Application diagram | 33 |
| 7.3 | Layout recommendations | 34 |
| 8 | Packaging | 35 |
| 8.1 | Package mechanical dimensions | 35 |
| 9 | Revision history | 39 |

1 Orderable parts

This section describes the part numbers available to be purchased along with their differences.

Table 1. Orderable part variations

| Part number | Notes | Temperature (T _A) | Package |
|--------------|-------|-------------------------------|-------------|
| MC33SA0528AC | (1) | -40 °C to 125 °C | 32-PIN LQFP |

Notes

1. To order parts in tape & reel, add the R2 suffix to the part number.

2 Internal block diagram

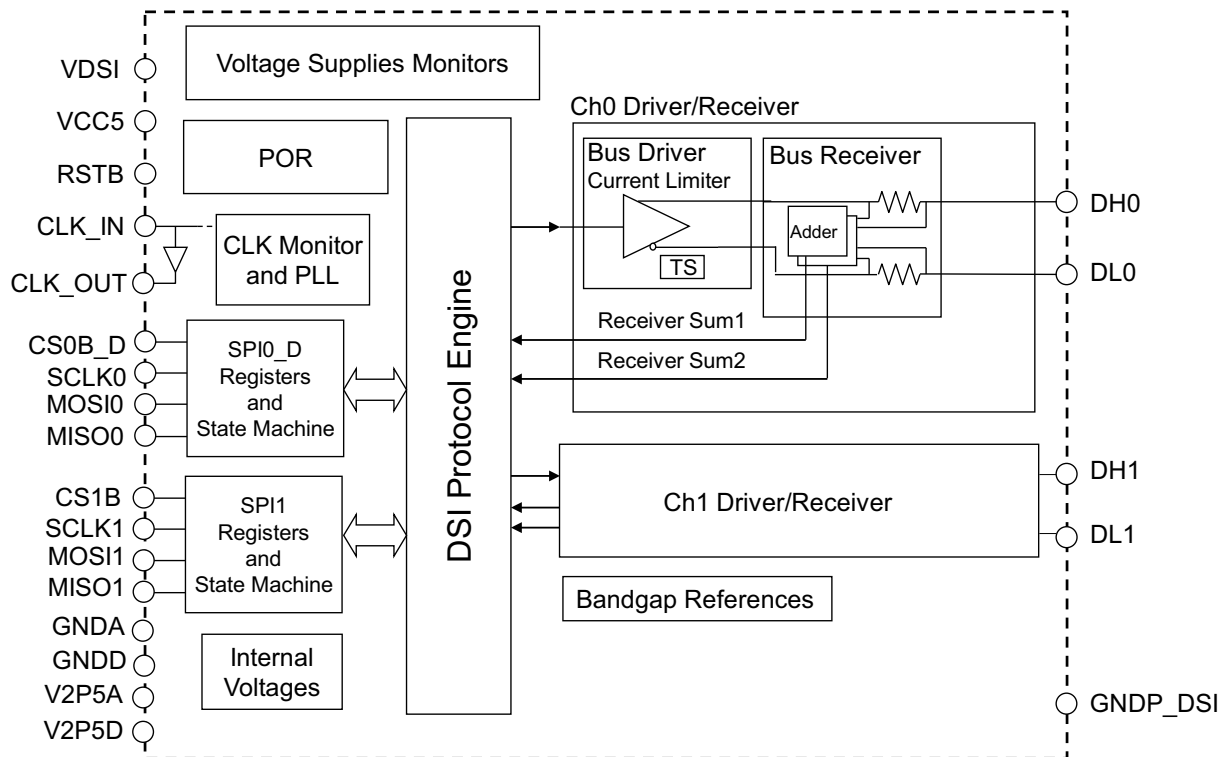

Figure 2. 33SA0528 simplified internal block diagram

3 Pin connections

3.1 Pinout diagram

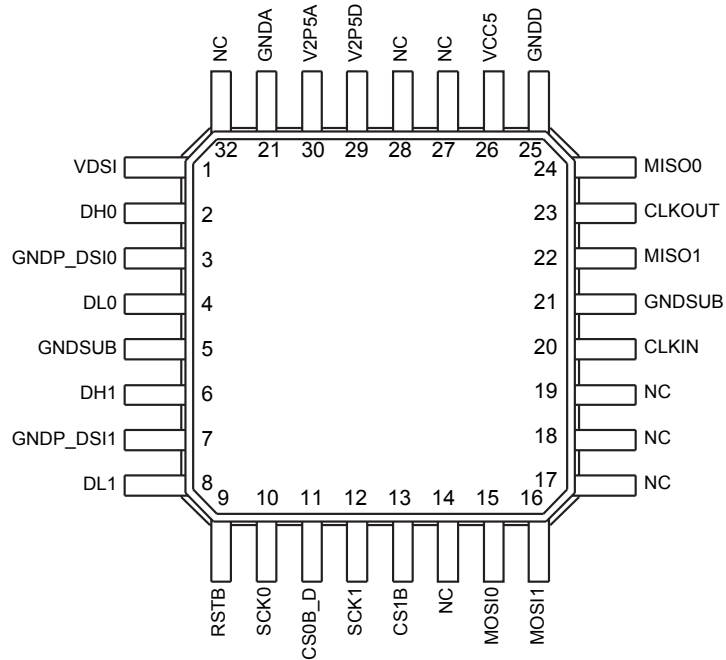

Figure 3. 33SA0528 32-pin LQFP pinout diagram

3.2 Pin definitions

A functional description of each pin can be found in the functional pin description section beginning on [page 9](#).

Table 2. 33SA0528 pin definitions

| Pin number | Pin name | Pin function | Definition |
|------------|----------|---------------|--|
| 1 | VDSI | Power | This supply input is used to provide the positive level output of buses |
| 2 | DH0 | Output driver | Bus 0 high-side |
| 3 | GND_DSI0 | Ground | Bus power return |
| 4 | DL0 | Output driver | Bus 0 low-side |
| 5 | GNDSUB | Ground | This pin must be tied to ground in the application. |
| 6 | DH1 | Output driver | Bus 1 high-side |
| 7 | GND_DSI1 | Ground | Bus power return |
| 8 | DL1 | Output driver | Bus 1 low-side |
| 9 | RSTB | Reset | A low level on this pin returns all registers to a known initial state. |
| 10 | SCK0 | Input | Clocks data in from and out to DSI_SPI0. MISO0 data changes on the negative transition of SCLK0. MOSI0 is sampled on the positive edge of SCLK0 |
| 11 | CS0B_D | Input | When this signal is high, SPI signals on DSI_SPI0 are ignored. Asserting this pin low starts a DSI_SPI0 transaction. The DSI_SPI0 transaction is signaled as completed when this signal returns high |
| 12 | SCK1 | Input | Clocks data in from and out to DSI_SPI1. MISO1 data changes on the negative transition of SCLK1. MOSI1 is sampled on the positive edge of SCLK1 |

Table 2. 33SA0528 pin definitions(continued)

| Pin number | Pin name | Pin function | Definition |
|------------|----------|--------------|--|
| 13 | CS1B | Input | When this signal is high, SPI signals on DSI_SPI1 are ignored. Asserting this pin low starts a DSI_SPI1 transaction. The DSI_SPI1 transaction is signaled as completed when this signal returns high |
| 14 | N.C | — | This pin is not internally connected and must be left unconnected or tied to ground in the application |
| 15 | MOSI0 | Input | SPI data into DSI_SPI0. This data input is sampled on the positive edge of SCLK0 |
| 16 | MOSI1 | Input | SPI data into DSI_SPI1. This data input is sampled on the positive edge of SCLK1 |
| 17 | N.C | — | This pin is not internally connected and must be left unconnected or tied to ground in the application |
| 18 | N.C | — | This pin is not internally connected and must be left unconnected or tied to ground in the application |
| 19 | N.C | — | This pin is not internally connected and must be left unconnected or tied to ground in the application |
| 20 | CLK_IN | Input | 4.0 MHz clock input |
| 21 | GNDSUB | Ground | This pin must be tied to ground in the application |
| 22 | MISO1 | Output | DSI_SPI1 data sent to the MCU by this device. This data output changes on the negative edge of SCLK1. When CS1B_D is high, this pin is high |
| 23 | CLK_OUT | Output | Output buffered clock signal that is input from CLK_IN |
| 24 | MISO0 | Output | DSI_SPI0 data sent to the MCU by this device. This data output changes on the negative edge of SCLK0. When CS0B_D is high, this pin is set at high impedance |
| 25 | GNDD | Ground | Ground for the digital circuits. Ground for IDDQ. This pin should be tied to MCU ground |
| 26 | VCC5 | Power | Regulated 5.0 V input |
| 27 | N.C | — | This pin is not internally connected and must be left unconnected or tied to ground in the application |
| 28 | N.C | — | This pin is not internally connected and must be left unconnected or tied to ground in the application |
| 29 | V2P5D | Output | 0.1 μ F capacitor should be connected between this pin and ground |
| 30 | V2P5A | Output | 0.1 μ F capacitor should be connected between this pin and ground |
| 31 | GNDA | Ground | Ground for the analog circuits. This pin is not connected internally to the other grounds on the chip. It should be connected to a quiet ground on the board |
| 32 | N.C | — | This pin is not internally connected and must be left unconnected or tied to ground in the application |

4 General product characteristics

4.1 Maximum ratings

Table 3. Maximum ratings

All voltages are with respect to ground unless otherwise noted. Exceeding these ratings may cause a malfunction or permanent damage to the device.

| Symbol | Description (rating) | Min. | Max. | Unit | Notes |
|---------------------------|---|------|-----------------|------|-------|
| Electrical ratings | | | | | |
| V_{DSI} | DSI bus voltage supply <ul style="list-style-type: none"> Steady-state | -0.3 | 10 | V | |
| V_{CC5} | V_{CC} logic supply voltage | -0.3 | 7.0 | V | |
| V_{2P5A} | Regulated output voltage | -0.3 | 3.0 | V | |
| V_{2P5D} | Regulated output voltage | -0.3 | 3.0 | V | |
| V_{LOGIC} | Voltage on logic input/output pins | -0.3 | $V_{CC5} + 3.0$ | V | |
| I_{LOGIC} | Current on logic input/output pins | — | 20 | mA | |
| V_{BUS} | Voltage on DSI bus pins | -0.3 | 20 | V | |
| I_{BUS} | Current on DSI bus pins | — | 200 | mA | |
| V_{ESD} | ESD voltage <ul style="list-style-type: none"> Human body model (HBM) Machine model (MM) Charge device model (CDM) | — | ±2000 | V | (2) |
| | | — | ±150 | | |
| | | — | ±500 | | |

Notes

- ESD testing is performed in accordance with the human body model (HBM) ($C_{ZAP} = 100$ pF, $R_{ZAP} = 1500$ Ω), the machine model (MM) ($C_{ZAP} = 200$ pF, $R_{ZAP} = 0$ Ω), and the charge device model.

4.2 Thermal characteristics

Table 4. Thermal ratings

All voltages are with respect to ground unless otherwise noted. Exceeding these ratings may cause a malfunction or permanent damage to the device.

| Symbol | Description (rating) | Min. | Max. | Unit | Notes |
|-----------|---|------|------|------|-------|
| T_A | Operating temperature <ul style="list-style-type: none"> Ambient | -40 | 105 | °C | |
| T_J | <ul style="list-style-type: none"> Junction | -40 | 150 | | |
| T_{STG} | Storage temperature | -55 | 150 | °C | |
| T_{SD} | Thermal shutdown (bus driver) | 155 | 195 | °C | |

4.3 Operating conditions

This section describes the operating conditions of the device. Conditions apply to all the following data, unless otherwise noted.

Table 5. Operating conditions

All voltages are with respect to ground unless otherwise noted. Exceeding these ratings may cause a malfunction or permanent damage to the device.

| Symbol | Ratings | Min. | Max. | Unit | Notes |
|------------------|--|------|------|------|-------|
| V _{DSI} | Full characteristics are guaranteed | 9.0 | 9.6 | V | |
| V _{DSI} | Some characteristics are out of specification, but the 33SA0528 can communicate with the bus slaves | 8.8 | 9.0 | V | |
| V _{DSI} | Some characteristics are out of specification, but the V _{DSI} monitor is active, so the RNE bit is never set | 8.2 | 8.8 | V | |
| V _{CC5} | Functional operating VCC5 voltage | 4.8 | 5.25 | V | |

4.4 Supply currents

This section describes the current consumption characteristics of the device, as well as the conditions for the measurements.

Table 6. Supply currents

All voltages are with respect to ground unless otherwise noted. Exceeding these ratings may cause a malfunction or permanent damage to the device. Typical values noted reflect the approximate parameter mean at T_A = 25 °C.

| Symbol | Ratings | Min. | Typ. | Max. | Unit | Notes |
|-------------------|--|-----------------|-----------------|-----------------|------|-------|
| I _{VDSI} | Current on DSI bus <ul style="list-style-type: none"> • 9.6 V (disabled) • 9.6 V (enabled 1.0 mA/channel) • 9.6 V (enabled 40 mA/channel) | 8.0 18 96 | 11 24 108 | 13 30 114 | mA | (3) |
| I _{VCC} | Current on VCC5 supply | — | — | 2.0 | mA | |

Notes

- I_{OUT} is the total current for all sensors connected to two DSI interfaces. For example: If 40 mA is flowing out (DHx to DLx) on each DSI channel, then I_{OUT} = 2 x 40 mA = 80 mA. The max. internal current flowing from VDSI to GND is '28 mA + (80 mA/14) = 34 mA'. The max. total current is flowing from VDSI (includes sensor current) is '34 mA + 80 mA = 114 mA'. If the DSI channel-0 is enabled and 40 mA is flowing out (DHx to DLx), the other DSI channel (ch1) is the disabled case. The max. internal current flowing from VDSI to GND is '19 mA + (40 mA/14) = 22 mA'. The Max. total current flowing from VDSI (include sensor current) is '22 mA + 40 mA = 62 mA'.

5 General IC functional description

5.1 Block diagram

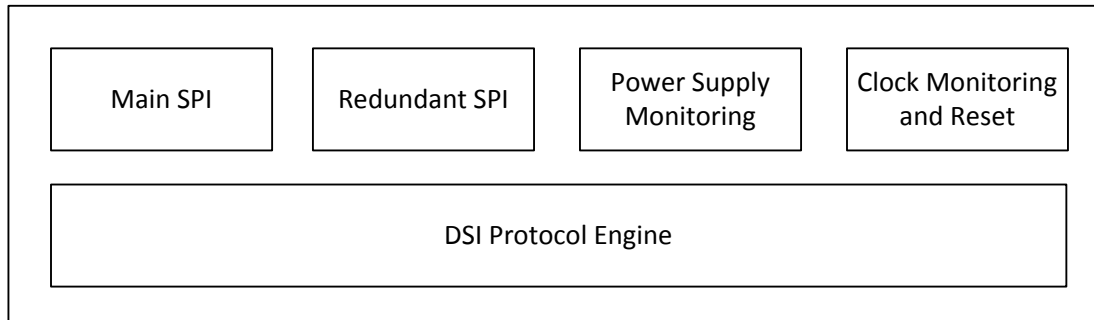

Figure 4. 33SA0528 functional block diagram

5.2 Features

- Main SPI at 10 MHz and 32-bit frame size provides access to all main registers
- Redundant SPI with the same format provides access to redundant registers with slaves' data, for safety purposes
- DSI protocol engine provides two independent channels to communicate and decode up to eight sensors
- Power supplies monitor detects and informs undervoltages on all four power pins (VDSI, VCC5, V2P5A, V2P5D)
- Internal PLL block generates 10 MHz stable frequency from 4.0 Mhz input clock
- Internal clock generator (no resonator) provides internal 4.0 MHz reference for clock frequency watchdog block
- Clock monitor sets proper flags if any abnormality is detected in clock or PLL frequencies

5.3 Functional description

The 33SA0528 is a DSI master device behaving as an interface between the MCU and the DSI slaves connected to the system bus. It supports up to four slaves connected to each of the two available DSI channels, allowing for a total of eight slaves. The MCU can access the registers in the 33SA0528 via two independent SPIs, the first one being for configuration purposes and to interact with the DSI slaves. The second one provides full redundancy of slaves' responses, which is designed for safety applications. The 33SA0528 can also act as a DSI Companion Chip when working together with a DSI SBC, expanding this last chip's capacity regarding the maximum number of DSI slaves it can decode.

5.4 Communication

5.4.1 SPI

Both SPI channels share the same speed and format, so only one MCU configuration scheme is needed to communicate with the 33SA0528. The maximum frequency of this interface is clocked at 10 MHz and provided by the internal PLL, generated from the 4.0 MHz clock input. Each command follows a 32-bit format, with the 5th byte being optional. The SPI is in-command full-duplex, which means the 33SA0528 responds during the same SPI frame in which it demands to read a register, meaning the device can write or read any register in just one SPI command.

5.4.2 DSI

The 33SA0528 provides an interface for a DSI Differential bus, having two independent channels. Each channel can drive and decode up to four slaves connected in either point-to-point, parallel, or resistor-based daisy-chained bus. For each channel, the DSI Receiver block provides a doubled redundancy when composing the differential (high/send and low/return) values read from the bus, which makes this device ideal for safety applications. For more information on the DSI protocol, refer to its consortium web site: <http://www.dsiconsortium.org>.

6 Functional block description

6.1 SPI

6.1.1 Block diagram

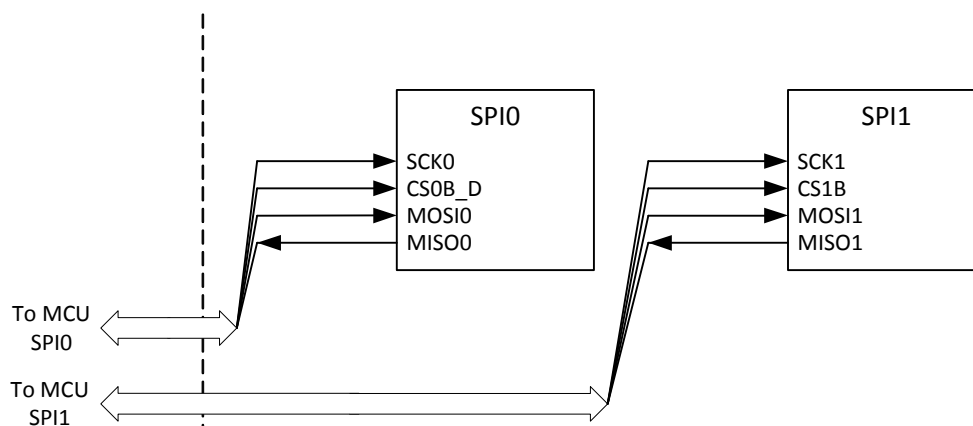

Figure 5. SPI modules pins and block diagram

6.1.2 Timings and configuration

The timings and commands format is the same for both SPI modules.

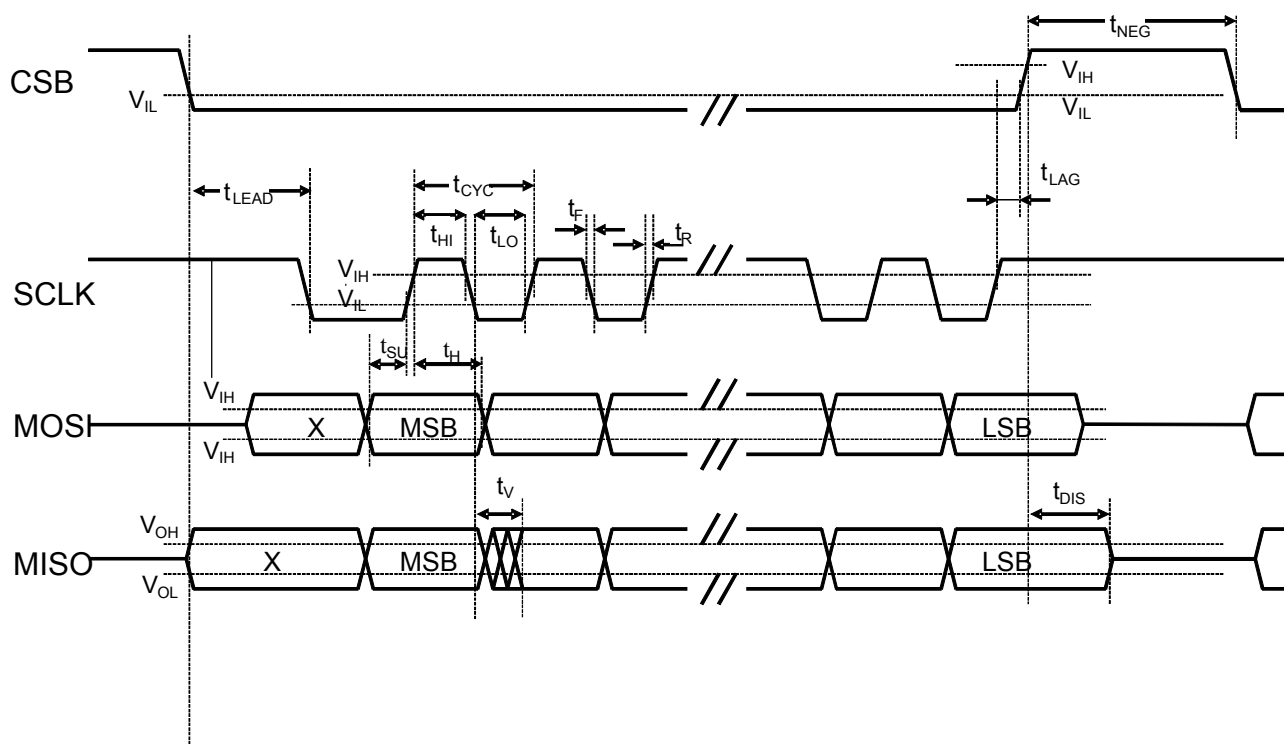

Figure 6. SPI modules timings

Table 7. SPI modules timings

| Symbol | Parameter | Min. | Typ. | Max. | Unit | Notes |
|------------|--|------|------|------|------|-------|
| t_{CYC} | SPI clock cycle time | 99 | — | — | ns | |
| t_{HI} | SPI clock high time | 40 | — | — | ns | |
| t_{LO} | SPI clock low time | 40 | — | — | ns | |
| t_{LEAD} | SPI chip select lead time | 50 | — | — | ns | |
| t_{LAG} | SPI chip select lag time | 50 | — | — | ns | |
| t_{SU} | Data setup time • MOSI valid after SCK rising edge | 10 | — | — | ns | |
| t_H | Data hold time • MOSI valid after SCK rising edge | 10 | — | — | ns | |
| t_V | Data valid time • SCK falling edge to MISO valid, C = 50 pF | — | — | 25 | ns | |
| t_{DIS} | Output disable time • CSB rise to MISO high-impedance | — | — | 50 | ns | |
| t_R | Rise time (30% V_{CC} to 70% V_{CC}) • SCK, MOSI | — | — | 10 | ns | |
| t_F | Fall time (70% V_{CC} to 30% V_{CC}) • SCK, MOSI | — | — | 10 | ns | |
| t_{NEG} | Chip select negate timer (read/write) | 600 | — | — | ns | |

6.1.3 Frame format

The SPI module transactions start with a command and address byte and can be followed by three or four bytes of data. The start of a SPI transaction is signaled by the CSB signal being asserted low. The first bit sent (bit 7) of the first byte signals a read (bit = '0') or write (bit = '1') operation. The last seven bits (bit 6 to 0) of the first byte indicate the address of the desired register. Both 4-byte access and 5-byte access are valid for all register address. During a SPI transaction the 33SA0528 checks for SPI framing errors. A framing error is defined as any number of clocks received which is neither 32 nor 40. If this occurs, all bits sent by the SPI master are discarded and no registers are updated.

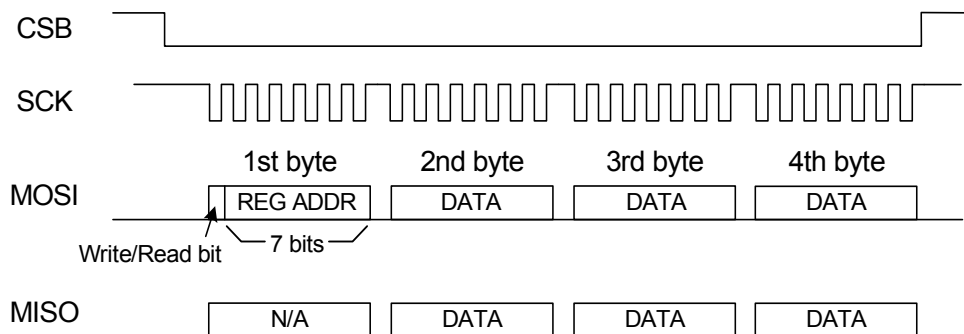

Figure 7. SPI module frames format - 4 byte access

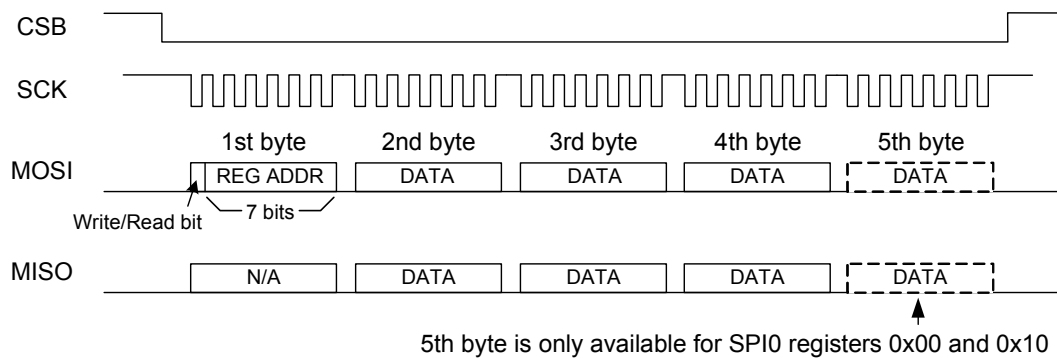

Figure 8. SPI modules frames format - 5 bytes access

6.1.4 Register maps

Table 8. SPI0 register map

| Address | Name | Type | 2nd byte | 3rd byte | 4th byte | 5th byte (optional) |
|---------|--------------------------|------|-------------|------------|------------|---------------------|
| 0x00 | CRM Tx/Rx Data Buffer D0 | R/W | D0DATA2 | D0DATA1 | D0DATA0 | D0RES_STAT |
| 0x01 | CRM Tx/Rx Data Buffer D0 | R | D0DATA1 | D0DATA0 | D0RES_STAT | — |
| 0x02 | PDCM Data Buffer D0R0 | R | D0R0DATA2 | D0R0DATA1 | D0R0DATA0 | — |
| 0x04 | PDCM Data Buffer D0R1 | R | D0R1DATA2 | D0R1DATA1 | D0R1DATA0 | — |
| 0x06 | PDCM Data Buffer D0R2 | R | D0R2DATA2 | D0R2DATA1 | D0R2DATA0 | — |
| 0x08 | PDCM Data Buffer D0R3 | R | D0R3DATA2 | D0R3DATA1 | D0R3DATA0 | — |
| 0x0A | PDCM Control D0 | R/W | D0PDCM_CTRL | D0PDCM_DLY | N/A | — |
| 0x0B | Channel Control D0 | R/W | D0CTRL | D0DPC | D0STAT | — |
| 0x0C | PDCM Configuration D0 | R/W | D0CHIP_TIME | D0SID_R0R1 | D0SID_R2R3 | — |
| 0x0E | Channel Clear D0 | R/W | D0CLR | N/A | N/A | — |
| 0x10 | CRM Tx/Rx Data Buffer D1 | R/W | D1DATA2 | D1DATA1 | D1DATA0 | D1RES_STAT |
| 0x11 | CRM Tx/Rx Data Buffer D1 | R | D1DATA1 | D1DATA0 | D1RES_STAT | — |
| 0x12 | PDCM Data Buffer D1R0 | R | D1R0DATA2 | D1R0DATA1 | D1R0DATA0 | — |
| 0x14 | PDCM Data Buffer D1R1 | R | D1R1DATA2 | D1R1DATA1 | D1R1DATA0 | — |
| 0x16 | PDCM Data Buffer D1R2 | R | D1R2DATA2 | D1R2DATA1 | D1R2DATA0 | — |
| 0x18 | PDCM Data Buffer D1R3 | R | D1R3DATA2 | D1R3DATA1 | D1R3DATA0 | — |
| 0x1A | PDCM Control D1 | R/W | D1PDCM_CTRL | D1PDCM_DLY | N/A | — |
| 0x1B | Channel Control D1 | R/W | D1CTRL | D1DPC | D1STAT | — |
| 0x1C | PDCM Configuration D1 | R/W | D1CHIP_TIME | D1SID_R0R1 | D1SID_R2R3 | — |
| 0x1E | Channel Clear D1 | R/W | D1CLR | N/A | N/A | — |
| 0x40 | NCKPTN | R | 0xAA | 0xAA | 0xAA | — |
| 0x41 | CHKPTN | R | 0x55 | 0x55 | 0x55 | — |
| 0x42 | MASKID | R | MASKID | — | — | — |

Notes

4. Dn registers refer to the DSI channel n, so D0 corresponds to channel 0 and D1 corresponds to channel 1.
5. Rm registers refer to the DSI slave addressed at m, so R0 corresponds to slave at address 0 and so on.
6. The registers that correspond to different DSI channels and addresses have the same format and description.

Table 9. SPI1 register map

| Address | Name | Type | 2nd byte | 3rd byte | 4th byte | 5th byte (optional) |
|---------|-----------------------|------|-----------|-----------|-----------|---------------------|
| 0x02 | PDCM Data Buffer D0R0 | R | D0R0DATA2 | D0R0DATA1 | D0R0DATA0 | - |
| 0x04 | PDCM Data Buffer D0R1 | R | D0R1DATA2 | D0R1DATA1 | D0R1DATA0 | - |
| 0x06 | PDCM Data Buffer D0R2 | R | D0R2DATA2 | D0R2DATA1 | D0R2DATA0 | - |
| 0x08 | PDCM Data Buffer D0R3 | R | D0R3DATA2 | D0R3DATA1 | D0R3DATA0 | - |
| 0x12 | PDCM Data Buffer D1R0 | R | D1R0DATA2 | D1R0DATA1 | D1R0DATA0 | - |
| 0x14 | PDCM Data Buffer D1R1 | R | D1R1DATA2 | D1R1DATA1 | D1R1DATA0 | - |
| 0x16 | PDCM Data Buffer D1R2 | R | D1R2DATA2 | D1R2DATA1 | D1R2DATA0 | - |
| 0x18 | PDCM Data Buffer D1R3 | R | D1R3DATA2 | D1R3DATA1 | D1R3DATA0 | - |
| 0x40 | NCKPTN | R | 0xAA | 0xAA | 0xAA | - |
| 0x41 | CHKPTN | R | 0x55 | 0x55 | 0x55 | - |

Notes

- These registers have the same format and description as their SPI0 counterparts, as they are just for redundancy purposes.

6.1.5 Registers description

6.1.5.1 CRM Tx/Rx data buffer Dn

Table 10. 2nd byte - DnDATA2

| Bit | 7 | 6 | 5 | 4 | 3 | 2 | 1 | 0 |
|-------|------------|------------|------------|------------|------------|------------|------------|------------|
| R | | | | | | | | |
| W | DnDATA[23] | DnDATA[22] | DnDATA[21] | DnDATA[20] | DnDATA[19] | DnDATA[18] | DnDATA[17] | DnDATA[16] |
| Reset | 0 | 0 | 0 | 0 | 0 | 0 | 0 | 0 |

Table 11. 3rd byte - DnDATA1

| Bit | 7 | 6 | 5 | 4 | 3 | 2 | 1 | 0 |
|-------|------------|------------|------------|------------|------------|------------|-----------|-----------|
| R | | | | | | | | |
| W | DnDATA[15] | DnDATA[14] | DnDATA[13] | DnDATA[12] | DnDATA[11] | DnDATA[10] | DnDATA[9] | DnDATA[8] |
| Reset | 0 | 0 | 0 | 0 | 0 | 0 | 0 | 0 |

Table 12. 4th byte - DnDATA

| Bit | 7 | 6 | 5 | 4 | 3 | 2 | 1 | 0 |
|-------|-----------|-----------|-----------|-----------|-----------|-----------|-----------|-----------|
| R | | | | | | | | |
| W | DnDATA[7] | DnDATA[6] | DnDATA[5] | DnDATA[4] | DnDATA[3] | DnDATA[2] | DnDATA[1] | DnDATA[0] |
| Reset | 0 | 0 | 0 | 0 | 0 | 0 | 0 | 0 |

Table 13. 5th byte - DnRES_STAT

| Bit | 7 | 6 | 5 | 4 | 3 | 2 | 1 | 0 |
|-----|----|---|---|----|----|-----|---|---|
| R | ER | - | - | UV | TE | RNE | 0 | 1 |

Table 13. 5th byte - DnRES_STAT

| Bit | 7 | 6 | 5 | 4 | 3 | 2 | 1 | 0 |
|-------|---|---|---|---|---|---|---|---|
| W | | | | | | | | |
| Reset | 0 | 0 | 0 | 0 | 1 | 0 | 0 | 1 |

Table 14. CRM Tx/Rx data buffer Dn fields description

| Field | Description |
|--------------|--|
| DnDATA[23:0] | CRM data to transmit or CRM data received from slaves If the DSI channel EN bit is set, and the 33SA0528 is not in PDCM, data is transmitted after being written to the register. Also, slaves' CRM data is written back to the buffer as soon as it is received through the bus. |
| ER | Error bit This bit indicates, for received data, there is either a CRC error, an undefined symbol error, or data mismatch between the dual DSI receivers. |
| UV | Undervoltage This bit indicates VDSI dropped below its minimum threshold for a specified time. Refer to Power supply monitor on page 30 . |
| TE | Transmit empty This bit indicates there is no data in the transmit buffer. |
| RNE | Receiver not empty This bit indicates there is data available that has been received from the slaves. |

6.1.5.2 PDCM data buffer DnRm

Table 15. 2nd byte - DnRmDATA2

| Bit | 7 | 6 | 5 | 4 | 3 | 2 | 1 | 0 |
|-------|----|---|-----|----|--------------|--------------|--------------|--------------|
| R | ER | - | RNE | UV | DnRmData[19] | DnRmData[18] | DnRmData[17] | DnRmData[16] |
| W | | | | | | | | |
| Reset | 0 | 0 | 0 | 0 | 0 | 0 | 0 | 0 |

Table 16. 3rd byte - DnRmDATA1

| Bit | 7 | 6 | 5 | 4 | 3 | 2 | 1 | 0 |
|-------|--------------|--------------|--------------|--------------|--------------|--------------|-------------|-------------|
| R | DnRmData[15] | DnRmData[14] | DnRmData[13] | DnRmData[12] | DnRmData[11] | DnRmData[10] | DnRmData[9] | DnRmData[8] |
| W | | | | | | | | |
| Reset | 0 | 0 | 0 | 0 | 0 | 0 | 0 | 0 |

Table 17. 4th byte - DnRmDATA0

| Bit | 7 | 6 | 5 | 4 | 3 | 2 | 1 | 0 |
|-------|-------------|-------------|-------------|-------------|-------------|-------------|-------------|-------------|
| R | DnRmData[7] | DnRmData[6] | DnRmData[5] | DnRmData[4] | DnRmData[3] | DnRmData[2] | DnRmData[1] | DnRmData[0] |
| W | | | | | | | | |
| Reset | 0 | 0 | 0 | 0 | 0 | 0 | 0 | 0 |

Table 18. PDCM data buffer DnRm fields description

| Field | Description |
|----------------|---|
| DnRmDATA[19:0] | PDCM data received from slaves DnRmDATA[19:16] represent the source ID field of the slave, and it is used as seed for CRC calculation. |
| ER | Error bit This bit indicates, for received data, that there is either a CRC error, an undefined symbol error, or data mismatch between the dual DSI receivers. |
| UV | Undervoltage This bit indicates VDSI dropped below its minimum threshold for a specified time. Refer to Power supply monitor on page 30 . |
| RNE | Receiver not empty This bit indicates there is data available that has been received from the slaves. |

6.1.5.3 PDCM control Dn

Table 19. 2nd byte - DnPDCM_CTRL

| Bit | 7 | 6 | 5 | 4 | 3 | 2 | 1 | 0 |
|-------|-------|---|---|---|---|---|--------|-----------|
| R | | | | | | | | |
| W | DnBRC | - | - | - | - | - | DnAUTO | DnPDCM_EN |
| Reset | 0 | 0 | 0 | 0 | 0 | 0 | 0 | 0 |

Table 20. 3rd byte - DnPDCM_DLY

| Bit | 7 | 6 | 5 | 4 | 3 | 2 | 1 | 0 |
|-------|----------|----------|----------|----------|----------|----------|----------|----------|
| R | | | | | | | | |
| W | DELAY[7] | DELAY[6] | DELAY[5] | DELAY[4] | DELAY[3] | DELAY[2] | DELAY[1] | DELAY[0] |
| Reset | 0 | 0 | 0 | 0 | 0 | 0 | 0 | 0 |

Table 21. PDCM control Dn fields description

| Field | Description |
|------------|---|
| DnBRC | Broadcast read command Each time this bit is set, a manual BRC is transmitted through the DSI bus. Only valid when DnPDCM_EN is 1 and DnAUTO is 0. |
| DnAUTO | Automatic BRC When this bit is set, a BRC is transmitted automatically through the DSI bus every 500 μs. Write access to this bit is ignored when DnPDCM_EN is 0. |
| DnPDCM_EN | Periodic data collection mode enable Once this bit is set, the 33SA0528 enters PDCM, preventing any CRM communication or any configuration change. This bit can be cleared by clearing the channel, by writing to the channel clear Dn register. |
| DELAY[7:0] | Broadcast read command delay This bits set the delay to be applied to both manual and automatic BRCs, from BRC bit set to its transmission through the DSI bus. It is calculated as $\text{Delay time} = \text{DELAY}[7:0] \times 5\text{clockcounts}$, with a range of 0 ~ 127.5 μs and a 0.5 μs step at 10 MHz. |

6.1.5.4 Channel control Dn

Table 22. 2nd byte - DnCTRL

| Bit | 7 | 6 | 5 | 4 | 3 | 2 | 1 | 0 |
|-------|---|---|---|---|----------|----|--------|--------|
| R | 0 | 0 | 0 | 0 | UVDSI_ON | EN | BCK[1] | BCK[0] |
| W | | | | | | | | |
| Reset | 0 | 0 | 0 | 0 | 0 | 0 | 0 | 0 |

Table 23. 3rd byte - DnDPC

| Bit | 7 | 6 | 5 | 4 | 3 | 2 | 1 | 0 |
|-------|---|---|---|---|---|--------|--------|--------|
| R | 0 | 0 | 0 | 0 | 0 | DPC[2] | DPC[1] | DPC[0] |
| W | | | | | | | | |
| Reset | 0 | 0 | 0 | 0 | 0 | 0 | 0 | 0 |

Table 24. 4th byte - DnSTAT

| Bit | 7 | 6 | 5 | 4 | 3 | 2 | 1 | 0 |
|-------|------|------|---------|---------|-----|-----|---|-----|
| R | CFM3 | CFM2 | GNDA_OP | GNDD_OP | OCS | TS | 0 | UV |
| W | w0c | w0c | w0c | w0c | w0c | w0c | | w0c |
| Reset | 0 | 0 | 0 | 0 | 0 | 0 | 0 | 0 |

Table 25. Channel control Dn fields description

| Field | Description |
|---------------|--|
| UVDSI_ON | VDSI undervoltage monitor test function This bit forces an undervoltage detection on the UVDSI monitor, for test purposes, by forcing its input to ground. 0: Normal operation. UVDSI module monitors the voltage in VDSI pin. 1: Test operation. UVDSI is forced to ground, so the UV bit in status registers should be set. |
| EN | DSI channel enable 0: Disable the DSI channel, if conditions are met. 1: Enable the DSI channel, if conditions are met. |
| BCK[1:0] | Buffer check mode If both these bits are set simultaneously (in the same SPI transaction), the 33SA0528 enters BCM. Refer to the DSI protocol engine module. Note that the BCK[1:0] bits have higher priority than EN and DPC[2:0], meaning if are three fields are written at the same time, only BCK[1:0] is considered. |
| DPC[2:0] | Discovery pulses count If conditions are met, setting these bits transmits the set number of discovery pulses through the DSI bus. Refer to DSI protocol engine on page 20 for required conditions. |
| CFM3 and CFM2 | Clock failure monitor flags CFM3=0 and CFM2=0: Normal case. Each bit can be cleared by writing a 0 to them. CFM3=1: The internal PLL in charge of generating the internal 10 MHz frequency is unlocked. CFM2=1: The clock watchdog indicates CLKIN is out of its 4.0 MHz accepted range. |
| GNDA_OP | GNDA open pin 0: Normal case. The bit can be cleared by writing a 0 to it. 1: GNDA pin is open. |
| GNDD_OP | GNDD open pin 0: Normal case. The bit can be cleared by writing a 0 to it. 1: GNDD pin is open. |
| OCS | Overcurrent shutdown 0: Normal case. The bit can be cleared by writing a 0 to it. 1: The DSI bus current limiter has worked for a certain amount of time. Refer to Power supply monitor on page 30 . |

Table 25. Channel control Dn fields description (continued)

| Field | Description |
|-------|--|
| TS | Thermal shutdown 0: Normal case. The bit can be cleared by writing a 0 to it. 1: The DSI bus thermal limit has been reached. Refer to Power supply monitor on page 30 . |
| UV | Undervoltage 0: Normal case. The bit can be cleared by writing a 0 to it. 1: VDSI dropped below its minimum threshold for a specified time. Refer to Power supply monitor on page 30 . |

6.1.5.5 PDCM configuration Dn

Table 26. 2nd byte - DnCHIP_TIME

| Bit | 7 | 6 | 5 | 4 | 3 | 2 | 1 | 0 |
|-------|---|---|---|---|---|---|-------------|-------------|
| R | 0 | 0 | 0 | 0 | 0 | 0 | CHIPTIME[1] | CHIPTIME[0] |
| W | | | | | | | | |
| Reset | 0 | 0 | 0 | 0 | 0 | 0 | 0 | 0 |

Table 27. 3rd byte - DnSID_R0R1

| Bit | 7 | 6 | 5 | 4 | 3 | 2 | 1 | 0 |
|-------|-----------|-----------|-----------|-----------|-----------|-----------|-----------|-----------|
| R | | | | | | | | |
| W | SID_R0[3] | SID_R0[2] | SID_R0[1] | SID_R0[0] | SID_R1[3] | SID_R1[2] | SID_R1[1] | SID_R1[0] |
| Reset | 0 | 0 | 0 | 0 | 0 | 0 | 0 | 0 |

Table 28. 4th byte - DnSID_R2R3

| Bit | 7 | 6 | 5 | 4 | 3 | 2 | 1 | 0 |
|-------|-----------|-----------|-----------|-----------|-----------|-----------|-----------|-----------|
| R | | | | | | | | |
| W | SID_R2[3] | SID_R2[2] | SID_R2[1] | SID_R2[0] | SID_R3[3] | SID_R3[2] | SID_R3[1] | SID_R3[0] |
| Reset | 0 | 0 | 0 | 0 | 0 | 0 | 0 | 0 |

Table 29. PDCM configuration Dn fields description

| Field | Description |
|---------------|--|
| CHIPTIME[3:0] | DSI responses chip time These bits set the chip duration to use when decoding the current responses from slaves in the DSI bus. 00: 3.0 μ s 01: 3.5 μ s 10: 4.0 μ s 11: 4.5 μ s |
| SID_Rm[3:0] | Source ID These bits set the expected source ID of the DSI slave at address m. These values are used as CRC seeds. |

6.1.5.6 Channel clear Dn

Table 30. 2nd byte - DnCLR

| Bit | 7 | 6 | 5 | 4 | 3 | 2 | 1 | 0 |
|-------|----------|----------|----------|----------|----------|----------|----------|----------|
| R | DnCLR[7] | DnCLR[6] | DnCLR[5] | DnCLR[4] | DnCLR[3] | DnCLR[2] | DnCLR[1] | DnCLR[0] |
| W | | | | | | | | |
| Reset | 0 | 0 | 0 | 0 | 0 | 0 | 0 | 0 |

Table 31. Channel clear Dn fields description

| Field | Description |
|------------|--|
| DnCLR[7:0] | Channel clear When writing 0xFF to this byte, all the registers of the corresponding channel n are reset to its initial values. |

6.1.5.7 NCKPTN

Table 32. 2nd byte - 0xAA

| Bit | 7 | 6 | 5 | 4 | 3 | 2 | 1 | 0 |
|-------|---|---|---|---|---|---|---|---|
| R | 1 | 0 | 1 | 0 | 1 | 0 | 1 | 0 |
| W | | | | | | | | |
| Reset | 1 | 0 | 1 | 0 | 1 | 0 | 1 | 0 |

Table 33. 3rd byte - 0xAA

| Bit | 7 | 6 | 5 | 4 | 3 | 2 | 1 | 0 |
|-------|---|---|---|---|---|---|---|---|
| R | 1 | 0 | 1 | 0 | 1 | 0 | 1 | 0 |
| W | | | | | | | | |
| Reset | 1 | 0 | 1 | 0 | 1 | 0 | 1 | 0 |

Table 34. 4th byte - 0xAA

| Bit | 7 | 6 | 5 | 4 | 3 | 2 | 1 | 0 |
|-------|---|---|---|---|---|---|---|---|
| R | 1 | 0 | 1 | 0 | 1 | 0 | 1 | 0 |
| W | | | | | | | | |
| Reset | 1 | 0 | 1 | 0 | 1 | 0 | 1 | 0 |

Table 35. NCKPTN fields description

| Field | Description |
|-------|--|
| 0xAA | Inverted pattern check This register and its bytes are meant to check validate the communication with the device. |

6.1.5.8 CHKPTN

Table 36. 2nd byte - 0x55

| Bit | 7 | 6 | 5 | 4 | 3 | 2 | 1 | 0 |
|-------|---|---|---|---|---|---|---|---|
| R | 0 | 1 | 0 | 1 | 0 | 1 | 0 | 1 |
| W | | | | | | | | |
| Reset | 0 | 1 | 0 | 1 | 0 | 1 | 0 | 1 |

Table 37. 3rd byte - 0x55

| Bit | 7 | 6 | 5 | 4 | 3 | 2 | 1 | 0 |
|-------|---|---|---|---|---|---|---|---|
| R | 0 | 1 | 0 | 1 | 0 | 1 | 0 | 1 |
| W | | | | | | | | |
| Reset | 0 | 1 | 0 | 1 | 0 | 1 | 0 | 1 |

Table 38. 4th byte - 0x55

| Bit | 7 | 6 | 5 | 4 | 3 | 2 | 1 | 0 |
|-------|---|---|---|---|---|---|---|---|
| R | 0 | 1 | 0 | 1 | 0 | 1 | 0 | 1 |
| W | | | | | | | | |
| Reset | 0 | 1 | 0 | 1 | 0 | 1 | 0 | 1 |

Table 39. CHKPTN fields description

| Field | Description |
|-------|---|
| 0x55 | Pattern check This register and its bytes are meant to check validate the communication with the device. |

6.1.5.9 MASKID

Table 40. 2nd byte - MASKID

| Bit | 7 | 6 | 5 | 4 | 3 | 2 | 1 | 0 |
|-------|-----------|-----------|-----------|-----------|-----------|-----------|-----------|-----------|
| R | MASKID[7] | MASKID[6] | MASKID[5] | MASKID[4] | MASKID[3] | MASKID[2] | MASKID[1] | MASKID[0] |
| W | | | | | | | | |
| Reset | | | | | | | | |

Table 41. MASKID fields description

| Field | Description |
|-------------|---|
| MASKID[7:0] | Mask ID These bits indicate the chip's silicon revision number |

6.1.6 Electrical characteristics

Table 42. SPI modules electrical characteristics

Typical values noted reflect the approximate parameter means at $T_A = 25\text{ }^\circ\text{C}$ under nominal conditions, unless otherwise noted.

| Symbol | Characteristic | Min. | Typ. | Max. | Unit | Notes |
|------------------------------------|---|-----------------|----------------|-----------------|---------------|-------|
| V_{IH} V_{IL} V_{HYST} | I/O logic levels (CSB, MOSI, SCK) <ul style="list-style-type: none"> Input high-voltage Input low-voltage Input hysteresis | 2.0 — 0.1 | — — 0.35 | — 0.9 0.8 | V | |
| C_I | Input capacitance <ul style="list-style-type: none"> CSB, MOSI, and SCK | — | — | 10 | pF | |
| V_{OL} | Output low voltage <ul style="list-style-type: none"> MISO pin = 1.0 mA | 0.0 | — | 0.5 | V | |
| V_{OH} | Output high voltage <ul style="list-style-type: none"> MISO pin = -1.0 mA | $V_{CC5} - 0.5$ | — | | V | |
| I_{MISO} | Output leakage current <ul style="list-style-type: none"> MISO pin = 0 V MISO pin = V_{CC5} | -10 -10 | — — | 10 10 | μA | |
| I_{PU} | SCK, CSB pull-up current <ul style="list-style-type: none"> $V_{OUT} = V_{CC5} - 2.0\text{ V}$ | -50 | -30 | -10 | μA | |
| I_{PD} | MOSI pull-down current <ul style="list-style-type: none"> $V_{OUT} = 1.0\text{ V}$ | 5.0 | 10 | 13 | μA | |

6.2 DSI protocol engine

6.2.1 Block diagram

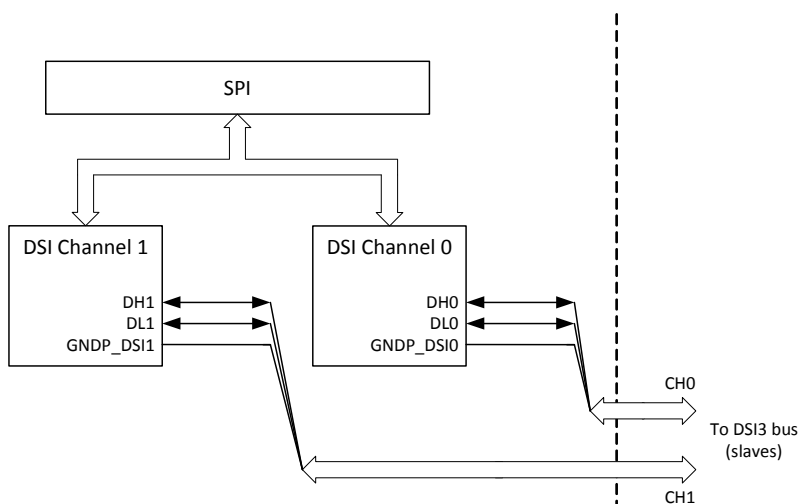

Figure 9. DSI modules pins and block diagram

6.2.2 DSI implementation parameters

6.2.2.1 Bus driver

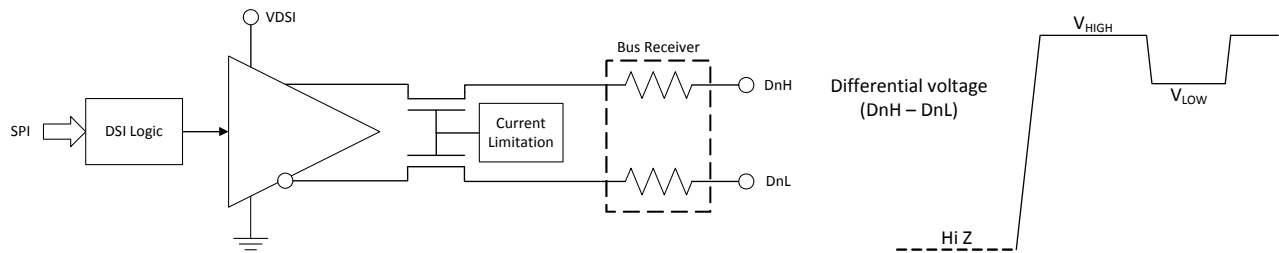

Figure 10. DSI bus driver block diagram

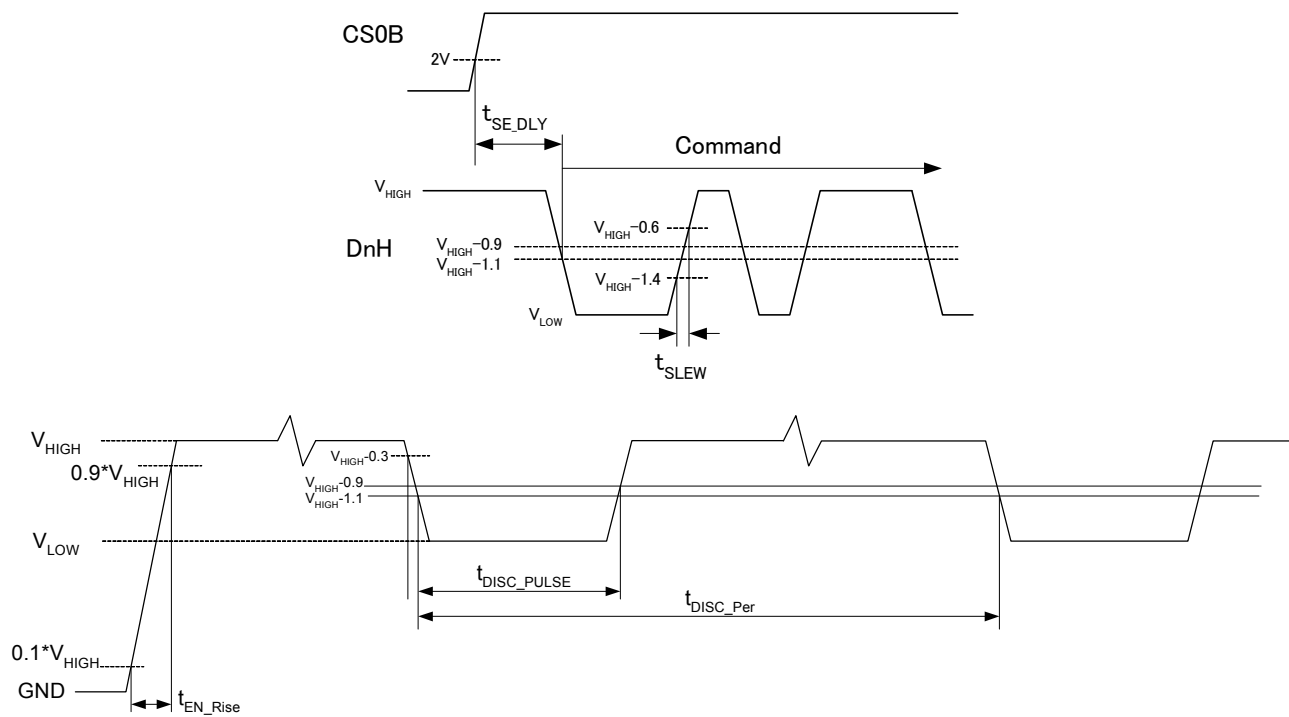

Figure 11. DSI bus voltages timings

Table 43. Bus driver characteristics

Characteristics noted under conditions $9.0\text{ V} \leq V_{\text{DSI}} < 9.6\text{ V}$, $4.8\text{ V} < V_{\text{CC5}} < 5.25\text{ V}$, $-40\text{ }^\circ\text{C} \leq T_{\text{A}} \leq 125\text{ }^\circ\text{C}$, unless otherwise noted. Typical values noted reflect the approximate parameter means at $T_{\text{A}} = 25\text{ }^\circ\text{C}$ under nominal conditions, unless otherwise noted. All parameters not mentioned in this table are compliant with those described in the DSI protocol specification, unless otherwise noted.

| Symbol | Characteristic | Min. | Typ. | Max. | Unit | Notes |
|--------------------------|---|-------------------------|------|-------------------------|------------------------|-------|
| V_{HIGH} | DSI voltage level high (DnH open, DnL open) | 7.5 | — | — | V | |
| V_{LOW} | DSI voltage level low (DnH open, DnL open) | $V_{\text{HIGH}} - 2.2$ | — | $V_{\text{HIGH}} - 1.8$ | V | |
| $V_{\text{HIGH_Drift}}$ | DSI high level voltage drift | -150 | — | 150 | mV | |
| | Common mode voltage peak to peak during single bit signal | — | — | 100 | mV | |
| R_{HIGH} | High-side output resistance | — | 3.0 | 5.4 | W | |
| R_{LOW} | Low-side output resistance | — | 3.0 | 5.4 | W | |
| R_{M} | Total output resistance ($R_{\text{HIGH}} + R_{\text{LOW}}$) | — | — | 10 | W | |
| D_{RATE} | Communication data rate | — | 125 | — | kbps | |
| $t_{\text{SE_DLY}}$ | Command start delay (CS0B rising edge to command start edge) <ul style="list-style-type: none"> • PDCM (DnPDCM_DLY = 0) • CRM | — | — | 1.5 | μs | |
| t_{SLEW} | Voltage signal slew rate | 2.0 | — | 6.0 | $\text{V}/\mu\text{s}$ | |
| $t_{\text{EN_Rise}}$ | Bus enable rising time | — | — | 10 | μs | |
| $t_{\text{DISC_PULSE}}$ | Self discovery pulse width | 15 | 16 | 17 | μs | |
| $t_{\text{DISC_PER}}$ | Self discovery pulse period | 120 | 125 | 130 | μs | |

6.2.2.2 Bus receiver

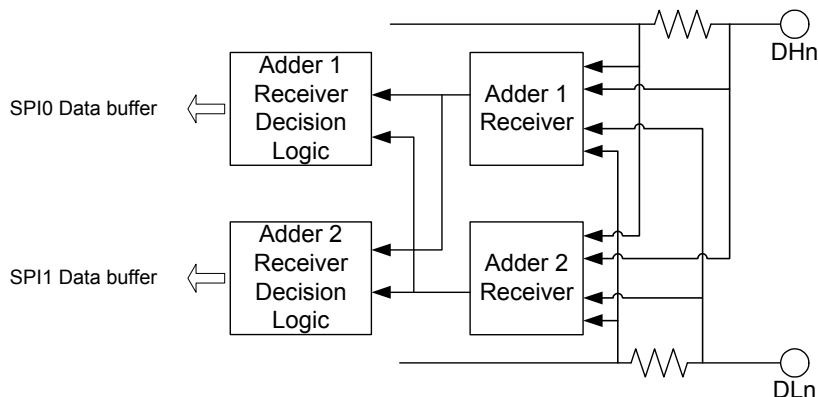

Figure 12. DSI bus receiver block diagram

The bus receiver presents doubled redundancy for safety purposes. It consists of two receivers and two independent decision logics.

- The first decision logic checks data integrity of the first receiver (referring to the second receiver), and transfers this data to SPI0 data buffer.
- The second decision logic checks data integrity of the second receiver (referring to the first receiver), and transfers this data to SPI1 data buffer.

The only case where ER bit is not set is given by satisfying all three conditions below. Any other case sets an ER bit.

- Receiver 1 CRC is OK
- Receiver 2 CRC is OK
- Receiver 1 XOR (bitwise) receiver 2 is OK

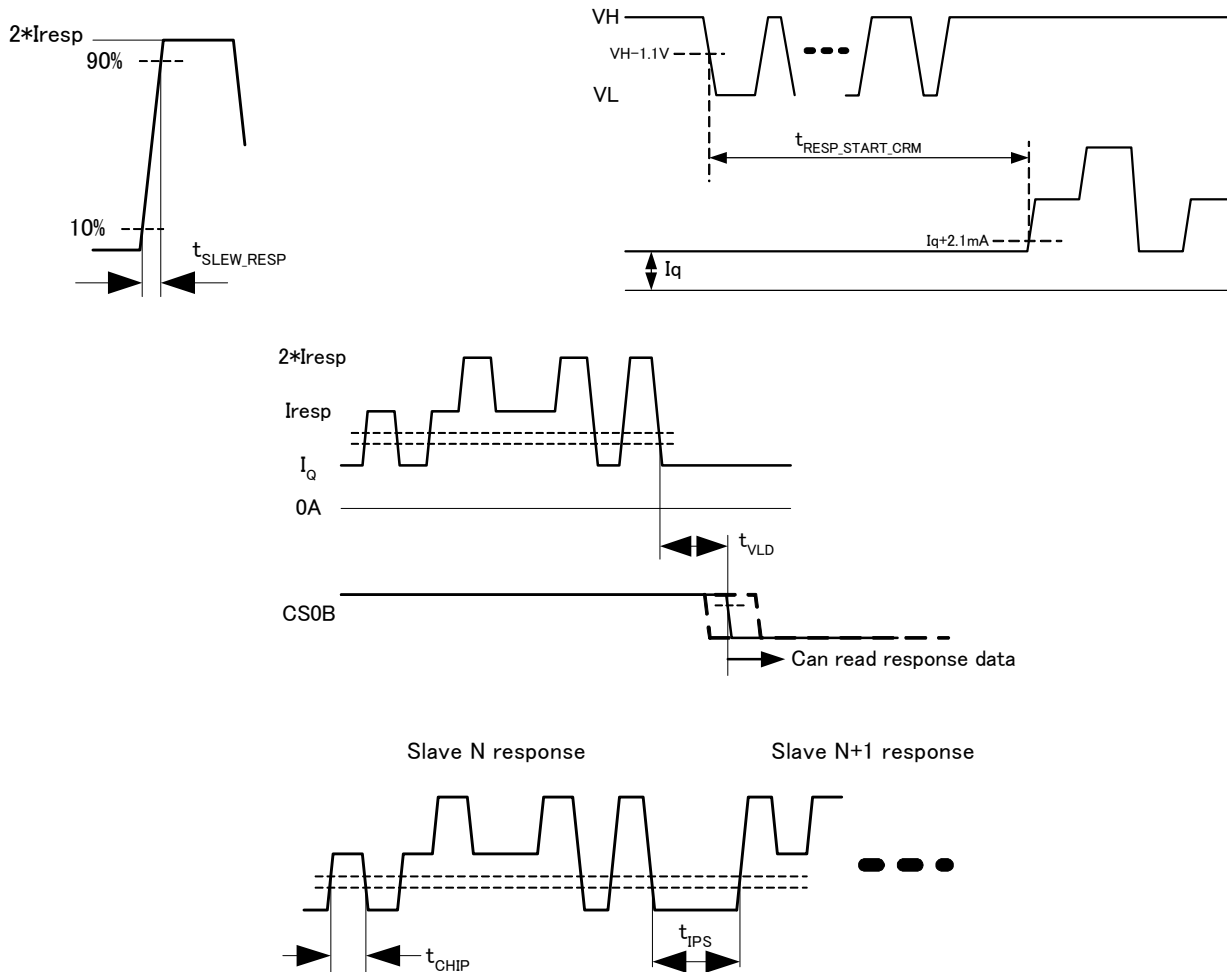

Figure 13. DSI bus currents timings

Table 44. Bus receiver characteristics

Characteristics noted under conditions $9.0\text{ V} \leq V_{\text{DSI}} < 9.6\text{ V}$, $4.8\text{ V} < V_{\text{CC5}} < 5.25\text{ V}$, $-40\text{ }^\circ\text{C} \leq T_{\text{A}} \leq 125\text{ }^\circ\text{C}$, unless otherwise noted. Typical values noted reflect the approximate parameter means at $T_{\text{A}} = 25\text{ }^\circ\text{C}$ under nominal conditions, unless otherwise noted. All parameters not mentioned in this table are compliant with those described in the DSI protocol specification, unless otherwise noted.

| Symbol | Characteristic | Min. | Typ. | Max. | Unit | Notes |
|------------------------------------|--|-----------------------------|------|-----------------------------|-------------------|-------|
| $I_{\text{Q_TOTAL}}$ | Total slaves quiescent current | - | - | 40 | mA | |
| $I_{\text{RESP_TH_LOW_DnH}}$ | Response current low threshold (receiver 1) | $I_{\text{Q_TOTAL}} + 5.0$ | - | $I_{\text{Q_TOTAL}} + 7.0$ | mA | |
| $I_{\text{RESP_TH_HIGH_DnH}}$ | Response current high threshold (receiver 1) | $I_{\text{Q_TOTAL}} + 15$ | - | $I_{\text{Q_TOTAL}} + 20$ | mA | |
| $I_{\text{RESP_TH_LOW_ADDER}}$ | Response current low threshold (receiver 2) | $I_{\text{Q_TOTAL}} + 5.0$ | - | $I_{\text{Q_TOTAL}} + 7.0$ | mA | |
| $I_{\text{RESP_TH_HIGH_ADDER}}$ | Response current high threshold (receiver 2) | $I_{\text{Q_TOTAL}} + 15$ | - | $I_{\text{Q_TOTAL}} + 20$ | mA | |
| $t_{\text{RESP_START_CRM}}$ | Response start time in command and response mode | 280 | 295 | 310 | μs | |
| $t_{\text{SLEW_RESP}}$ | Response current slew rate | 21 | - | 45 | mA/ μs | |
| $t_{\text{CHIP_CRM}}$ | Chip time in command and response mode | 4.75 | 5.0 | 5.25 | μs | |

Table 44. Bus receiver characteristics (continued)

Characteristics noted under conditions $9.0\text{ V} \leq V_{\text{DSI}} < 9.6\text{ V}$, $4.8\text{ V} < V_{\text{CC5}} < 5.25\text{ V}$, $-40\text{ }^\circ\text{C} \leq T_{\text{A}} \leq 125\text{ }^\circ\text{C}$, unless otherwise noted. Typical values noted reflect the approximate parameter means at $T_{\text{A}} = 25\text{ }^\circ\text{C}$ under nominal conditions, unless otherwise noted. All parameters not mentioned in this table are compliant with those described in the DSI protocol specification, unless otherwise noted.

| Symbol | Characteristic | Min. | Typ. | Max. | Unit | Notes |
|------------------|-------------------------|------|------|------|---------------|-------|
| t_{VLD} | Data valid time | - | - | 1.0 | μs | |
| t_{PS} | Inter packet separation | 3.0 | - | - | chips | |

6.2.3 Block logic and operation

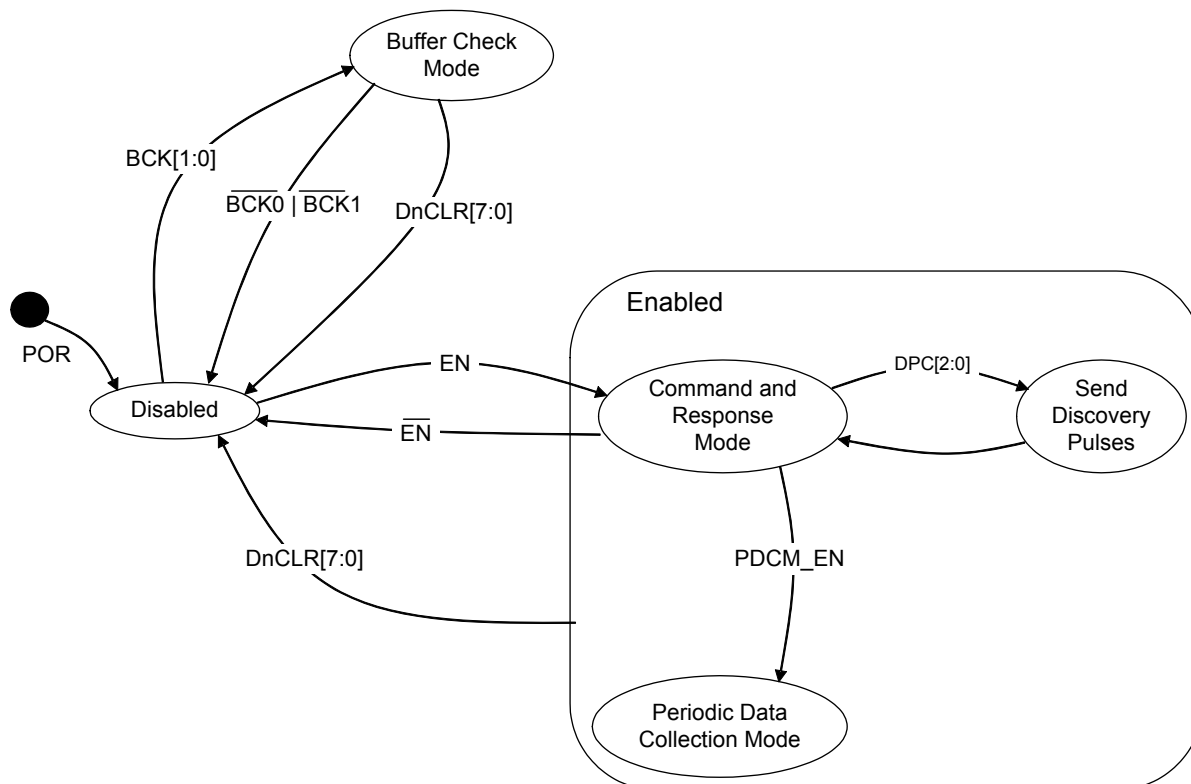

Figure 14. DSI block main states diagram for channel n

There are three states in the DSI protocol engine's logic for each channel: disabled, enabled and buffer check mode. In the disabled state, all SPI data buffers are reset to their initial values and any write access to the Tx buffer is ignored. The enabled state contains two modes, command and response mode, and periodic data collection mode. In command and response mode, the MCU can request the 33SA0528 to transceive any data (Tx/Rx buffers) or DSI discovery pulses to the DSI slaves in the bus. In periodic data collection mode, the DSI master stores and decodes four slaves responses per channel after every broadcast read command is sent through the DSI bus, which happens every $500\text{ }\mu\text{s}$ if in auto mode, or manually each time the DnBRC bit is set.

6.2.3.1 Command and response mode

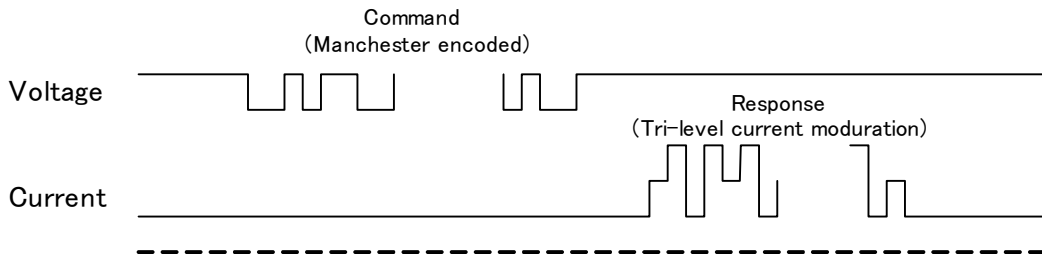

Figure 15. DSI Command and response mode operating principle

In this mode, any data written to the CRM Tx/Rx data buffer registers by the MCU, via SPI0, is outputted through the DSI bus as Manchester encoded voltage pulses, composing a command. The DSI slaves connected to the bus then receive this command and, if applicable, send back their responses following a tri-level current modulation, as detailed in the DSI protocol specification. The response is decoded by the DSI block and stored back to the corresponding CRM Tx/Rx Data Buffer register.

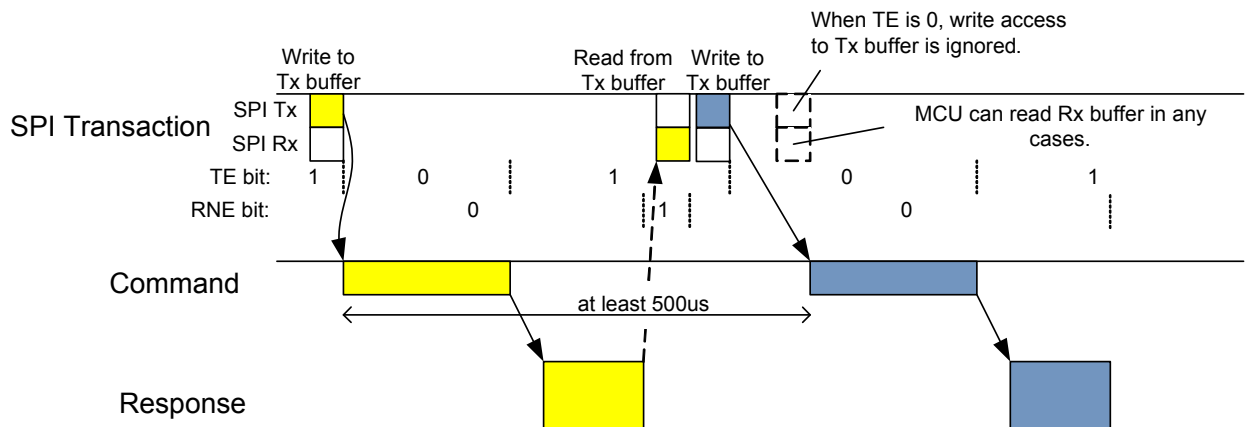

Figure 16. Command and response mode behavior on TE and RNE bits

The DSI voltage command is transmitted through the DSI bus immediately after the MCU completes writing data, via SPI0, to the CRM Tx/Rx data buffer register. This is not valid if the elapsed time from the start of the previous command is less than 500 μ s. If the MCU writes data to the CRM Tx buffer when the TE bit is set (TE=1) and 500 μ s have not yet elapsed from the start of the previous command, a new command is queued and outputted once this time is concluded. When the TE bit is cleared (TE=0), any MCU write operation to the CRM Tx buffer are ignored. However, the MCU can read the CRM Rx Data Buffer at any time.

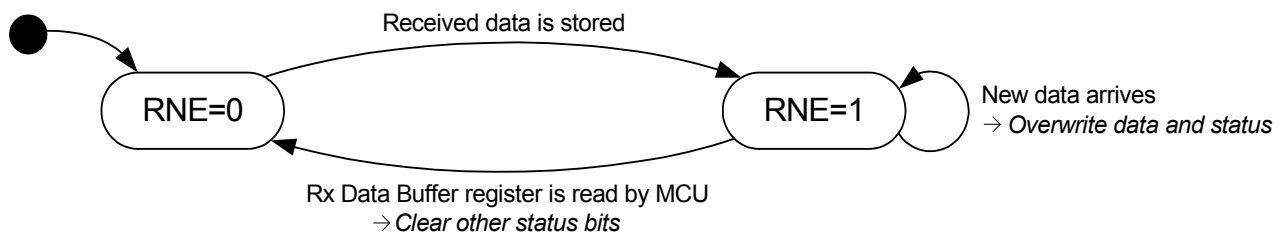

Figure 17. Command and response mode RNE bit behavior

If a DSI slave response is detected by the receiver logic, the RNE bit is set (RNE=1), indicating there is new data in the buffer. When the MCU reads the Rx data buffer register, the RNE bit clears (RNE=0). If another DSI slave response is detected with the receiver not being empty, the Rx data buffer overwrites with the new data and the RNE bit is kept set (RNE=1).

To enter into command and response mode, the corresponding EN bit from the channel control register must be set (EN=1). If BCK[1:0] bits and EN bit are set in the same SPI transaction, the operation on the EN bit is ignored as the BCK bits have higher priority.

There are two ways to exit this mode (note that data buffers are cleared entering into disabled mode):

- Clear the corresponding EN bit (EN=0).
- Write 0xFF to the DnCLR byte of the channel clear register in SPI0.

6.2.3.2 Discovery pulses

The 33SA0528 can send DSI discovery commands as detailed in the DSI protocol specification, for the automatic addressing of the slaves connected to the bus (discovery mode). For this, the device must first enter command and response mode.

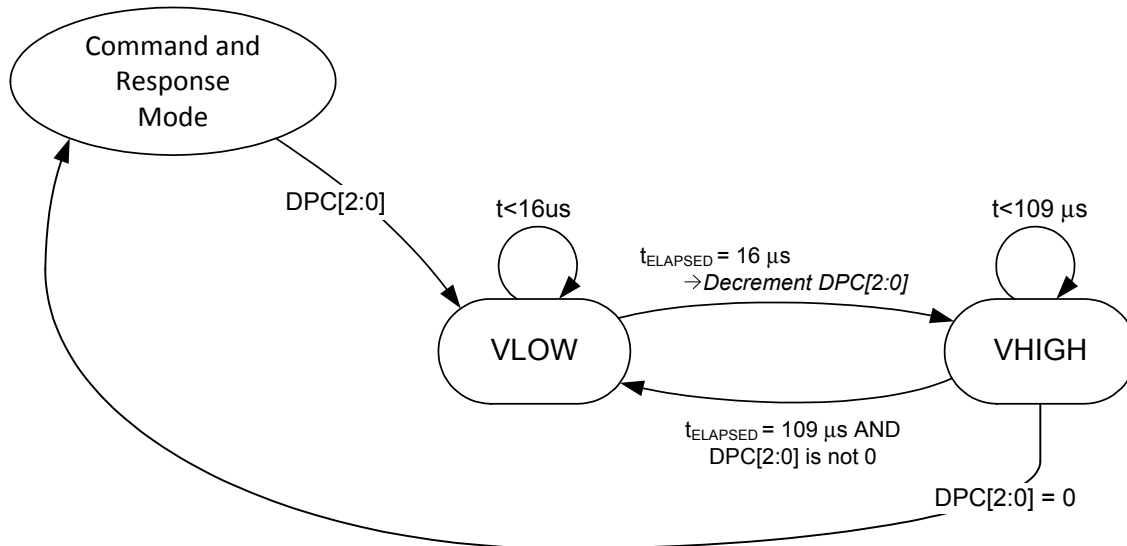

Figure 18. Send discovery pulses behavior

When writing a non-zero value to the DPC[2:0] bits of the corresponding channel control register, a series of voltages pulses are sent through the DSI bus, between V_{LOW} and V_{HIGH} . The number of pulses is the value written to the DPC bits and, as detailed in the DSI protocol specification, it must be equal or higher to the number of DSI slaves to be addressed. Once all the pulses have been transmitted, the device goes back to command and response mode.

6.2.3.3 Periodic data collection mode

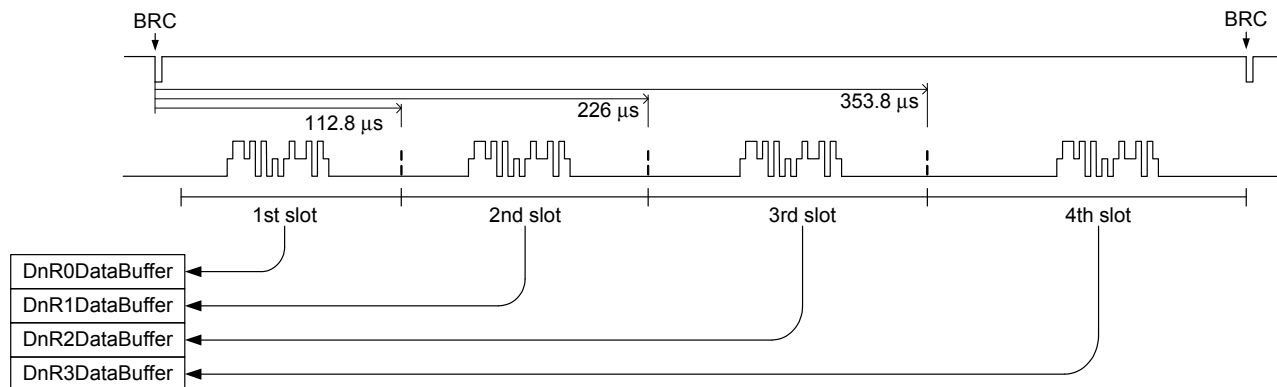

Figure 19. DSI periodic data collection mode operating principle

In this mode, the 33SA0528 can send special voltage pulses through the DSI bus, called broadcast read commands, after which it stores all received responses to the corresponding SPI0 and SPI1 PDCM data buffer registers. The responses must be separated following a TDMA approach, as defined in the DSI protocol specification.

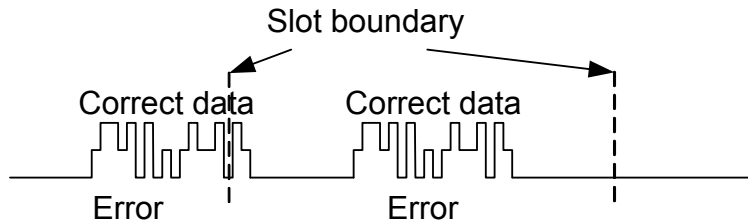

Figure 20. Periodic data collection mode time slots

The current-modulated responses from the DSI slaves must be contained between the boundaries of one of the four available time slots. Each time slot has an associated PDCM data buffer DnRm register. If two or more responses overlap each other, the ER bit of the corresponding data buffer register is set (ER=1).

Table 45. Periodic data collection mode time slots and data buffer registers

| Address | Time slot | SPI0 data buffer | SPI1 data buffer |
|---------|---------------------|-----------------------|-----------------------|
| 1 | 20 - 112.8 μ s | PDCM data buffer DnR0 | PDCM data buffer DnR0 |
| 2 | 112.8 - 226 μ s | PDCM data buffer DnR1 | PDCM data buffer DnR1 |
| 3 | 226 - 353.8 μ s | PDCM data buffer DnR2 | PDCM data buffer DnR2 |
| 4 | 353.8 - 500 μ s | PDCM data buffer DnR3 | PDCM data buffer DnR3 |

The 33SA0528 features two modes for transmitting the BRC: manual mode for single shot transmissions, and automatic mode where a BRC is sent every 500 μ s.

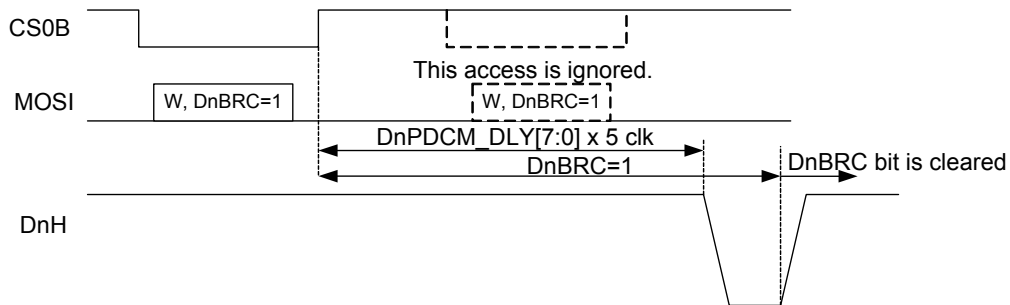

Figure 21. Periodic data collection mode manual BRC

If the DnAUTO bit is cleared (DnAUTO=0), the device works in manual mode, so a single BRC transmits through the DSI bus when setting the corresponding DnBRC bit (DnBRC=1) in the PDCM control register of SPI0. Any subsequent write access to the DnBRC bit is ignored until the DSI BRC pulse is transmitted and the DnBRC bit gets cleared (DnBRC=0). The transmission occurs after the configured PDCM delay has elapsed from the moment the BRC bit was set. The delay is calculated as five clock times the value on the corresponding PDCM_DLY[7:0] bits.

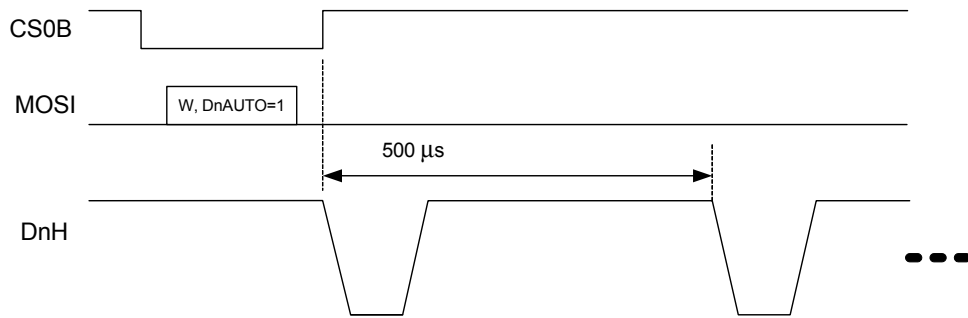

Figure 22. Periodic data collection mode automatic BRC

At the moment the DnAUTO bit is set (DnAUTO=1), a BRC transmits right after the SPI0 transmission finishes, and with a periodicity of 500 µs. Write access to this bit is ignored when the corresponding DnPDCM_EN bit is cleared (DnPDCM_EN=0).

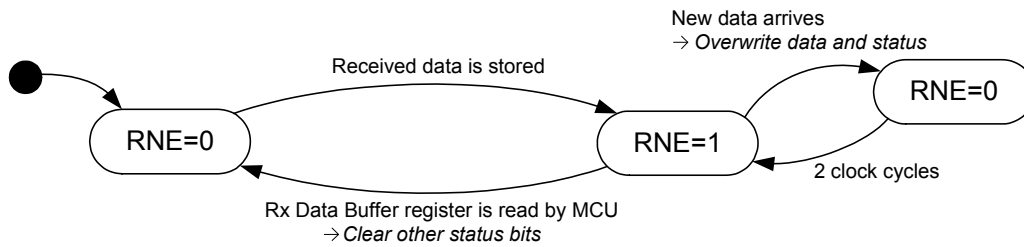

Figure 23. Periodic data collection mode RNE bit behavior

For each of the PDCM data buffer registers, when a DSI slave response is detected by the receiver logic the RNE bit is set (RNE=1), indicating there is new data in the buffer. When the MCU reads the Rx data buffer register, the RNE bit is cleared (RNE=0). If another DSI slave response is detected with the receiver not being empty, the Rx data buffer overwrites with the new data and the RNE bit is cleared (RNE=0) and then reset after two clock cycles (RNE=1).

To enter into periodic data collection mode, the corresponding PDCM_EN bit from the PDCM control register must be set (PDCM_EN=1). To exit this mode, a 0xFF must be written to the corresponding DnCLR[7:0] bits (note that all of the corresponding channel registers are cleared as they enter into disabled mode).

6.2.3.4 Buffer check mode

This mode tests and verifies the state of the buffers (for stuck-at bits checking, for example) by routing them internally to other registers. When in this mode, all data written to the SPI0 Tx buffer registers is not transmitted over the DSI bus, but instead copied to each of the periodic data buffer registers, both in SPI0 and SPI1. This action sets the associated RNE bits of the Rx registers. The Tx bytes to Rx bytes routing are done as follows:

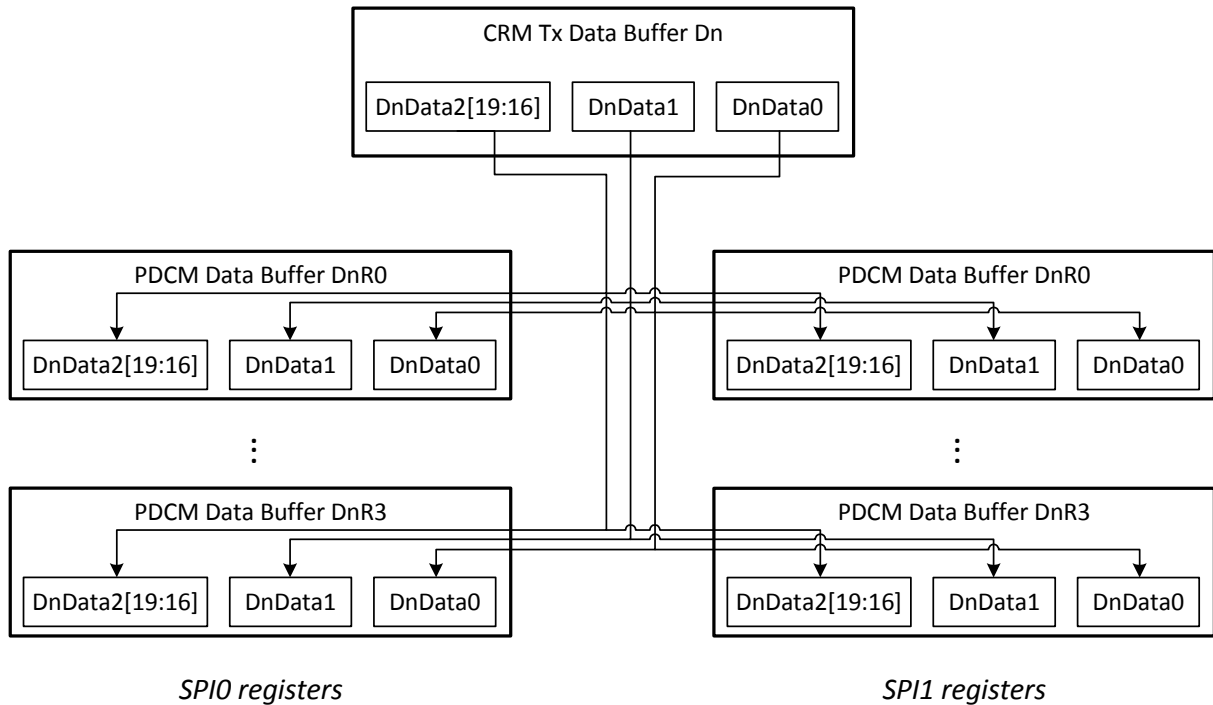

Figure 24. Buffer check mode bytes routing

To enter into this mode, both BCK0 and BCK1 bits must be set in the same SPI0 transaction.

There are two ways to exit this mode and so, go back to the disabled state:

1. Clear any of BCK0 or BCK1 bits by writing a 0 to them.
2. Clear the channel by writing the CLR[7:0] bits.

6.3 Bus driver protection

The bus driver has a current limiter and protection circuit with the following features.

- Limiting the current output through DHn and DLn to a specific value.
- Overcurrent shutdown of the corresponding DSI channel (current over threshold for a specified time).
- Thermal shutdown of the corresponding DSI channel (temperature over threshold for a specified time).

The corresponding bits in the SPI registers are set to indicate the condition met.

Table 46. Bus driver protection characteristics

Characteristics noted under conditions $9.0\text{ V} \leq V_{\text{DSI}} < 9.6\text{ V}$, $4.8\text{ V} < V_{\text{CC5}} < 5.25\text{ V}$, $-40\text{ }^\circ\text{C} \leq T_{\text{A}} \leq 125\text{ }^\circ\text{C}$, unless otherwise noted. Typical values noted reflect the approximate parameter means at $T_{\text{A}} = 25\text{ }^\circ\text{C}$ under nominal conditions, unless otherwise noted. All parameters not mentioned in this table are compliant with those described in the DSI protocol specification, unless otherwise noted.

| Symbol | Characteristic | Min. | Typ. | Max. | Unit | Notes |
|--------------------------------------|---|---------------------|-------------|------------------|---------------|-------|
| $I_{\text{LIM_DNH(SINK)}}$ | High-side current limit (sink) | 100 | — | 200 | mA | |
| $I_{\text{LIM_DNH(SOURCE)}}$ | High-side current limit (source) | -200 | — | -120 | mA | |
| $I_{\text{LIM_DNL(SINK)}}$ | Low-side current limit (sink) | 100 | — | 200 | mA | |
| $I_{\text{LIM_DNL(SOURCE)}}$ | Low-side current limit (source) | -200 | — | -120 | mA | |
| $I_{\text{LK_DNH}}$ CT RT, HT | Disabled high-side leakage <ul style="list-style-type: none"> • $\text{DHn} \leq V_{\text{DSI}}$ • $\text{DHn} \leq V_{\text{DSI}}$ • $V_{\text{DSI}} < \text{DHn} < 16\text{ V}$ | -35 -10 -1000 | — — — | 10 10 1000 | μA | |

Table 46. Bus driver protection characteristics (continued)

Characteristics noted under conditions $9.0\text{ V} \leq V_{\text{DSI}} < 9.6\text{ V}$, $4.8\text{ V} < V_{\text{CC5}} < 5.25\text{ V}$, $-40\text{ }^\circ\text{C} \leq T_{\text{A}} \leq 125\text{ }^\circ\text{C}$, unless otherwise noted. Typical values noted reflect the approximate parameter means at $T_{\text{A}} = 25\text{ }^\circ\text{C}$ under nominal conditions, unless otherwise noted. All parameters not mentioned in this table are compliant with those described in the DSI protocol specification, unless otherwise noted.

| Symbol | Characteristic | Min. | Typ. | Max. | Unit | Notes |
|-----------------------|---|--------------|--------|------------|---------------|-------|
| $I_{\text{LK_DNL}}$ | Disabled low-side leakage <ul style="list-style-type: none"> $\text{DHn} \leq V_{\text{DSI}}$ $V_{\text{DSI}} < \text{DHn} < 16\text{ V}$ | -10 -1000 | — — | 10 1000 | μA | |
| $t_{\text{OCS_DLY}}$ | Overcurrent shutdown delay | 230 | 320 | 560 | μs | |

6.4 Power supply monitor

This block is responsible of monitoring the voltages on pins VDSI, VCC5, V2P5A, and V2P5D.

6.4.1 Monitor behavior

6.4.1.1 VDSI

If the voltage on this pin drops below the defined voltage threshold for longer than the voltage threshold mask time, the 33SA0528 continues to send queued DSI commands, but takes following actions:

- Not setting any RNE bit in the data buffer registers
- Setting UV bits in the data buffer registers and DnSTAT registers

These actions continues until one of following condition is applied:

- The device is reset by POR
- DnCLR[7:0] bits are set to 0xFF in one SPI transaction
- EN bits in DnCTRL registers are cleared and then reset (EN = 0 then EN = 1)

Finally, if VDSI falls below the VDSI voltage reset threshold, the device is reset.

6.4.1.2 VCC5

If V_{CC5} voltage falls below its undervoltage threshold, the 33SA0528 is reset. In the case of V_{CC5} rising, the device is activated after a specific deglitch time from the threshold crossing point. In the case of V_{CC5} falling, the device is reset after a specific deglitch time from the threshold crossing point.

6.4.1.3 V2P5A and V2P5D

If any of the voltages fall below the corresponding threshold level, the 33SA0528 resets.

6.4.2 Electrical parameters

Table 47. Power supply monitor characteristics

Characteristics noted under conditions $9.0\text{ V} \leq V_{\text{DSI}} < 9.6\text{ V}$, $4.8\text{ V} < V_{\text{CC5}} < 5.25\text{ V}$, $-40\text{ }^\circ\text{C} \leq T_{\text{A}} \leq 125\text{ }^\circ\text{C}$, unless otherwise noted. Typical values noted reflect the approximate parameter means at $T_{\text{A}} = 25\text{ }^\circ\text{C}$ under nominal conditions, unless otherwise noted. All parameters not mentioned in this table are compliant with those described in the DSI protocol specification, unless otherwise noted.

| Symbol | Characteristic | Min. | Typ. | Max. | Unit | Notes |
|-----------------------|------------------------------|------|------|------|---------------|-------|
| $V_{\text{DSI_UV}}$ | VDSI voltage low threshold | 8.2 | 8.5 | 8.8 | V | |
| $t_{\text{DSI_UV}}$ | Deglitch time | 13 | 16 | 25 | μs | |
| $V_{\text{DSI_RST}}$ | VDSI voltage reset threshold | — | — | 5.5 | V | |
| $t_{\text{DSI_RST}}$ | Deglitch time (analog) | 4.0 | 6.0 | 12.5 | μs | |

Table 47. Power supply monitor characteristics (continued)

Characteristics noted under conditions $9.0\text{ V} \leq V_{\text{DSI}} < 9.6\text{ V}$, $4.8\text{ V} < V_{\text{CC5}} < 5.25\text{ V}$, $-40\text{ }^\circ\text{C} \leq T_{\text{A}} \leq 125\text{ }^\circ\text{C}$, unless otherwise noted. Typical values noted reflect the approximate parameter means at $T_{\text{A}} = 25\text{ }^\circ\text{C}$ under nominal conditions, unless otherwise noted. All parameters not mentioned in this table are compliant with those described in the DSI protocol specification, unless otherwise noted.

| Symbol | Characteristic | Min. | Typ. | Max. | Unit | Notes |
|-----------------------------|---|------|-------|------|---------------|-------|
| $V_{\text{CC5_UV1}}$ | VCC5 undervoltage threshold for system reset | 4.5 | 4.65 | 4.8 | V | |
| $t_{\text{CC5_UV1_RISE}}$ | When VCC5 ramps up, time delay from VCC5 pass over the undervoltage threshold to start reset recovery | 13 | 16 | 25 | μs | |
| $t_{\text{CC5_UV1_FALL}}$ | When VCC5 ramps down, time delay from VCC5 pass below the undervoltage threshold to reset activation | 13 | 16 | 25 | μs | |
| $V_{2\text{P5A_UV}}$ | Internal analog supply undervoltage threshold | 2.0 | 2.175 | 2.35 | V | |
| $V_{2\text{P5D_UV}}$ | Internal digital supply undervoltage threshold | 2.0 | 2.175 | 2.35 | V | |
| $t_{2\text{P5A_UV}}$ | Internal analog supply undervoltage detection deglitch time | 0.5 | 1.0 | 2.5 | μs | |
| $t_{2\text{P5D_UV}}$ | Internal digital supply undervoltage detection deglitch time | 0.5 | 1.0 | 4.0 | μs | |
| $V_{\text{GNDA_OPEN}}$ | Analog ground connection open detection threshold | 0.2 | 0.3 | 0.4 | V | |
| $V_{\text{GNDD_OPEN}}$ | Digital ground connection open detection threshold | 0.2 | 0.3 | 0.4 | V | |
| $t_{\text{GNDA_OPEN}}$ | Deglitch time of analog ground connection open detection | 13 | 16 | 25 | μs | |
| $t_{\text{GNDD_OPEN}}$ | Deglitch time of digital ground connection open detection | 13 | 16 | 25 | μs | |

6.5 Clock and reset module

6.5.1 Block diagram

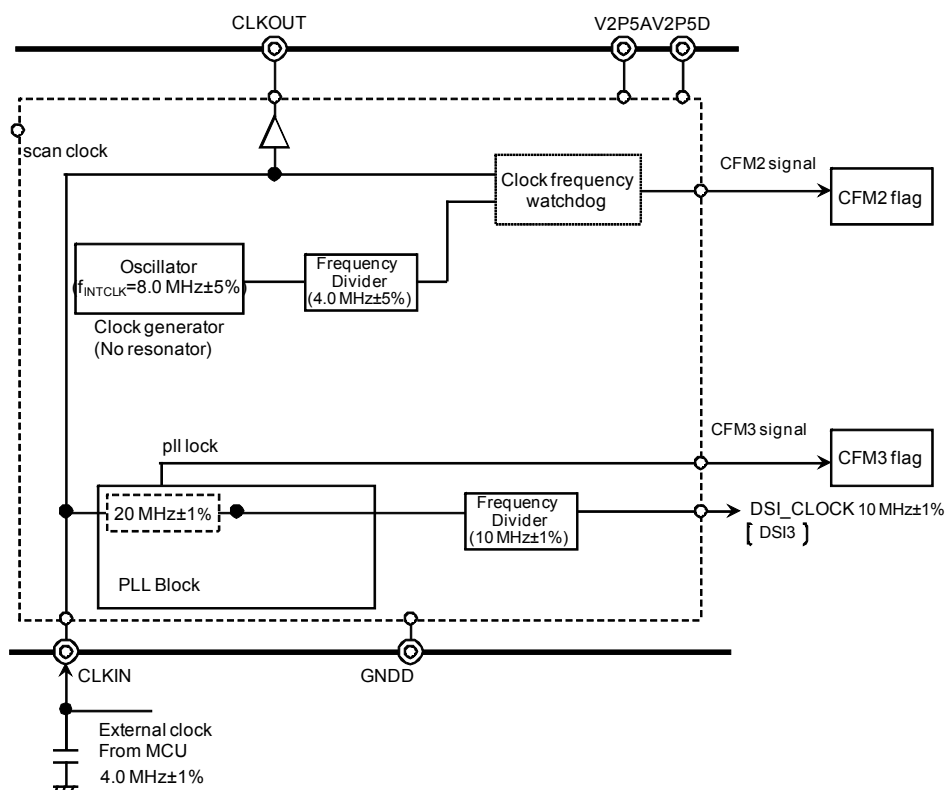

Figure 25. Clock module pins and block diagram

The clock module takes a 4.0 MHz clock source from the CLKIN pin. This frequency is usually provided by the MCU. As an output, it provides this same frequency through a buffer connected to the CLKOUT pin.

This module has an internal frequency generator used as reference to detect abnormalities in CLKIN. If any abnormality is detected, the CFM2 bit of the channel control registers in SPI0 is set (CFM2=1).

The clock module also includes a PLL block that generates a 10 MHz frequency from CLKIN. This generated frequency is used for the DSI protocol engine logic. If the PLL block is unstable (i.e. PLL unlocked), the CFM3 bit of the channel control registers in SPI0 is set (CFM3=1).

When any of both CFM2 or CFM3 bits are set, the 10 MHz frequency is tied to low level, meaning the DSI protocol engine is not functional, as it is lacking its input clock. Each flag can be cleared (CFMx=0) by writing a 0 to it via SPI communication.

6.5.2 Electrical parameters

Table 48. Clock and reset module characteristics

Characteristics noted under conditions $9.0\text{ V} \leq V_{\text{DSI}} < 9.6\text{ V}$, $4.8\text{ V} < V_{\text{CC5}} < 5.25\text{ V}$, $-40\text{ }^\circ\text{C} \leq T_{\text{A}} \leq 125\text{ }^\circ\text{C}$, unless otherwise noted. Typical values noted reflect the approximate parameter means at $T_{\text{A}} = 25\text{ }^\circ\text{C}$ under nominal conditions, unless otherwise noted. All parameters not mentioned in this table are compliant with those described in the DSI protocol specification, unless otherwise noted.

| Symbol | Characteristic | Min. | Typ. | Max. | Unit | Notes |
|---|--|------------------------|----------------|-----------------|---------------|-------|
| V_{IH} V_{IL} V_{HYST} | I/O logic levels (RSTB, CLKIN) <ul style="list-style-type: none"> Input high-voltage Input low-voltage Input hysteresis | 2.0 — 0.1 | — — 0.35 | — 0.9 0.8 | V | |
| C_{I} | Input capacitance <ul style="list-style-type: none"> RSTB and CLK | — | — | 20 | pF | |
| V_{OL} | Output low-voltage <ul style="list-style-type: none"> CLKOUT pin = 1.0 mA | 0.0 | — | 0.5 | V | |
| V_{OH} | Output high-voltage <ul style="list-style-type: none"> CLKOUT pin = 1.0 mA | $V_{\text{CC5}} - 0.5$ | — | — | V | |
| I_{RSTBPD} | RSTB pull-down resistor | 100 | 200 | 400 | k Ω | |
| I_{PD} | CLKIN pull-down current <ul style="list-style-type: none"> $V_{\text{OUT}} = 1.0\text{ V}$ | 5.0 | 10 | 13 | μA | |
| f_{INTCLK} | Internal clock frequency | -5.0% | 8.0 | +5.0% | MHz | |
| $f_{\text{CLKIN_WD_FALL}}$ | External input clock watchdog unusual fall frequency | 3.50 | 3.76 | 3.91 | MHz | |
| $f_{\text{CLKIN_WD_RISE}}$ | External input clock watchdog unusual rise frequency | 4.09 | 4.26 | 4.58 | MHz | |
| $t_{\text{CLKIN_WD}}$ | Clock frequency watchdog detect time | — | — | 64 | μs | |
| $t_{\text{CLKIN_TRAN}}$ | External input clock transfer function design guarantee | — | — | 10 | ns | |
| $f_{\text{CLKIN_OP}}$ | CLKIN input frequency for PLL operating <ul style="list-style-type: none"> PLL ratio vs. CLKIN $3.76\text{ MHz} \leq \text{CLKIN} \leq 4.24\text{ MHz}$ $V_{\text{2P5D}} > 2.0\text{ V}$ | 4.95 | 5.0 | 5.05 | | |
| $t_{\text{CLKIN_HI}}$ | CLKIN periods time high | 75 | — | — | ns | |
| $t_{\text{CLKIN_LO}}$ | CLKIN periods time low | 75 | — | — | ns | |
| $t_{\text{CLKIN_PER}}$ | CLKIN period | 245 | 250 | 255 | ns | |
| $t_{\text{CLKIN_LH}}$ | CLKIN transition time for low to high | — | — | 100 | ns | |
| $t_{\text{CLKIN_HL}}$ | CLKIN transition time for high to low | — | — | 100 | ns | |
| $t_{\text{CLKIN_JITT}}$ | CLKIN clock edge jitter for PLL operating | -25 | — | 25 | ns | |
| $t_{\text{PLL_LOCK}}$ | PLL lock time for first lock | — | 10 | 40 | μs | |
| $t_{\text{PLL_RELOCK}}$ | PLL lock time for re-lock | — | 15 | 30 | μs | |

7 Typical applications

7.1 Introduction

The 33SA0528 is a standalone, dual-channel DSI transceiver. This means it can act on its own as a direct interface between an MCU and up to eight DSI slaves. The MCU communicates with the 33SA0528 via its SPI0 (for device configuration and DSI operation) and its SPI1 (for DSI slaves' data redundancy). The device can also work as a companion chip for a DSI system basis chip master. In this case, the 33SA0528 is used to expand the channels of the DSI SBC, increasing in turn the maximum number of slaves which can be connected to the system. The main advantage of the companion chip operation is the SBC master's internal safing logic can access the 33SA0528 DSI data, making this configuration ideal for safety applications.

7.2 Application diagram

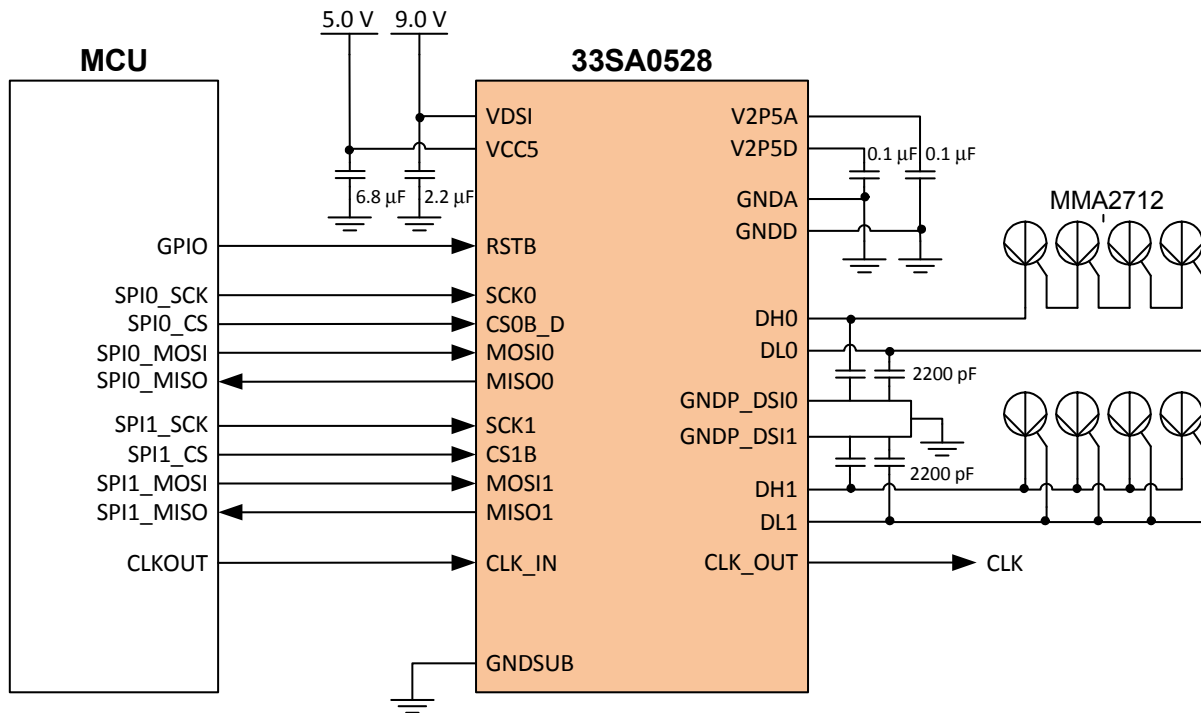

Figure 26. 33SA0528 typical application schematic as standalone transceiver

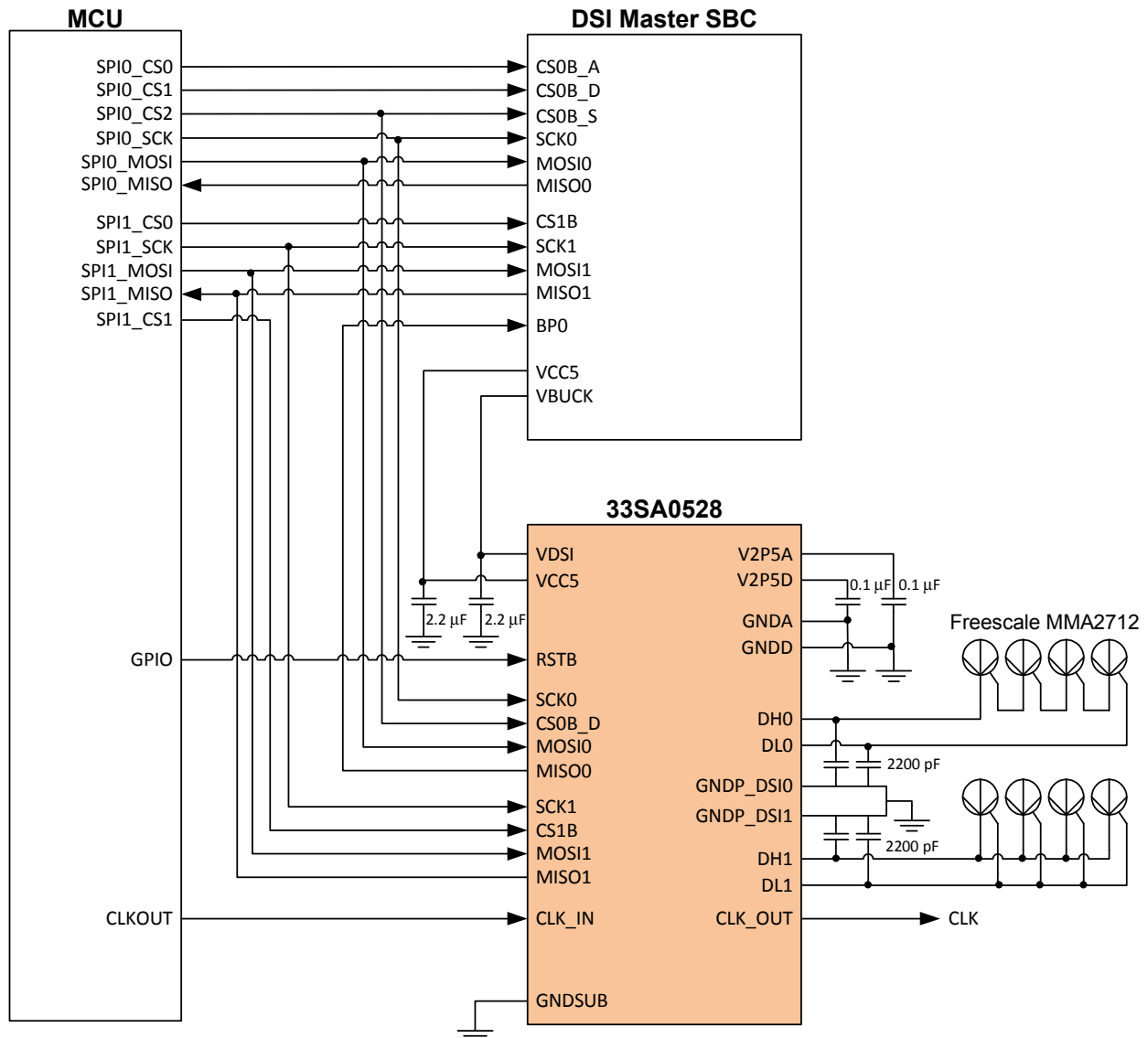

Figure 27. 33SA0528 typical application schematic as a companion chip

7.3 Layout recommendations

NXP recommends placing the components as described below:

- VDSI to ground 2.2 μF capacitor to be placed close to the chip
- VCC5 to ground 2.2 μF capacitor to be placed close to the chip
- V2P5A to GND 0.1 μF capacitor to be placed close to GND pin
- V2P5D to GND 0.1 μF capacitor to be placed close to GND pin
- DHn, DLn to GNDP_DSIn 2200 pF capacitors to be placed close to the corresponding GNDP_DSIn pin

8 Packaging

8.1 Package mechanical dimensions

Package dimensions are provided in package drawings. To find the most current package outline drawing, go to www.nxp.com and perform a keyword search for the drawing's document number.

| Package | Suffix | Package Outline Drawing Number |
|-------------|--------|--------------------------------|
| 32-Pin LQFP | AC | 98ASH70029A |

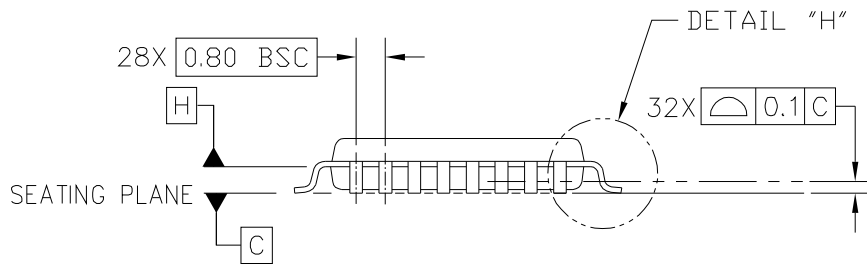
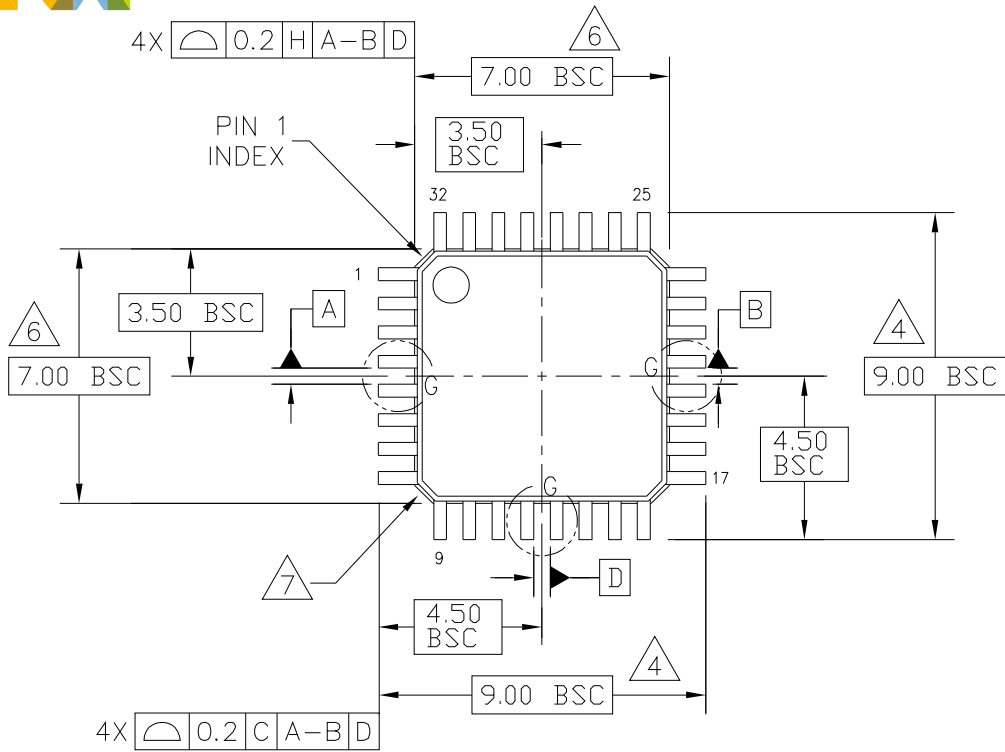

| | | |
|---|----------------------------|----------------------------|
| © NXP SEMICONDUCTORS N.V. ALL RIGHTS RESERVED | MECHANICAL OUTLINE | PRINT VERSION NOT TO SCALE |
| TITLE: LOW PROFILE QUAD FLAT PACK (LQFP) 32 LEAD, 0.8 PITCH (7 X 7 X 1.4) | DOCUMENT NO: 98ASH70029A | REV: F |
| | STANDARD: JEDEC MS-026 BBA | |
| | SQT358-3 | 01 APR 2016 |

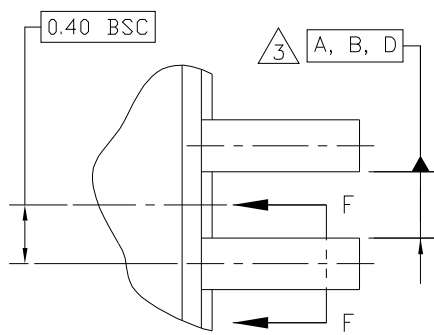

DETAIL G

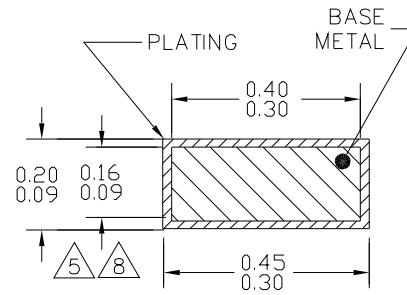

$\text{M} \text{ } \text{C} \text{ } \text{A-B D}$

SECTION F-F
ROTATED 90°CW
32 PLACES

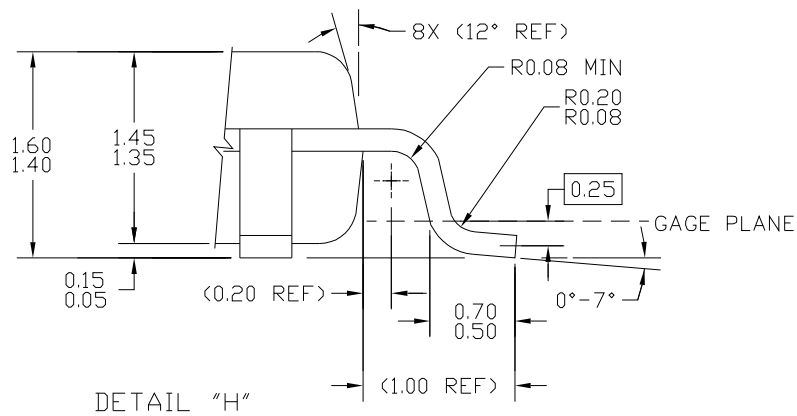

DETAIL "H"

| | | |
|---|----------------------------|----------------------------|
| © NXP SEMICONDUCTORS N.V. ALL RIGHTS RESERVED | MECHANICAL OUTLINE | PRINT VERSION NOT TO SCALE |
| TITLE: LOW PROFILE QUAD FLAT PACK (LQFP) 32 LEAD, 0.8 PITCH (7 X 7 X 1.4) | DOCUMENT NO: 98ASH70029A | REV: F |
| | STANDARD: JEDEC MS-026 BBA | |
| | SOT358-3 | 01 APR 2016 |



NOTES:

1. DIMENSIONS ARE IN MILLIMETERS.
2. INTERPRET DIMENSIONS AND TOLERANCES PER ASME Y14.5-1994.
3. DATUMS A, B, AND D TO BE DETERMINED AT DATUM PLANE H.
4. DIMENSIONS TO BE DETERMINED AT SEATING PLANE DATUM C.
5. DIMENSION DOES NOT INCLUDE DAMBAR PROTRUSION. ALLOWABLE DAMBAR PROTRUSION SHALL NOT CAUSE THE LEAD WIDTH TO EXCEED THE MAXIMUM DIMENSION BY MORE THAN 0.08 MM. DAMBAR CANNOT BE LOCATED ON THE LOWER RADIUS OR THE FOOT. MINIMUM SPACE BETWEEN PROTRUSION AND ADJACENT LEAD OR PROTRUSION: 0.07 MM.
6. DIMENSIONS DO NOT INCLUDE MOLD PROTRUSION. ALLOWABLE PROTRUSION IS 0.25 MM PER SIDE. DIMENSIONS ARE MAXIMUM PLASTIC BODY SIZE DIMENSIONS INCLUDING MOLD MISMATCH.
7. EXACT SHAPE OF EACH CORNER IS OPTIONAL.
8. THESE DIMENSIONS APPLY TO THE FLAT SECTION OF THE LEAD BETWEEN 0.1 MM AND 0.25 MM FROM THE LEAD TIP.

| | | | |
|---|--------------------|----------------------------|-------------|
| © NXP SEMICONDUCTORS N.V. ALL RIGHTS RESERVED | MECHANICAL OUTLINE | PRINT VERSION NOT TO SCALE | |
| TITLE: LOW PROFILE QUAD FLAT PACK (LQFP) 32 LEAD, 0.8 PITCH (7 X 7 X 1.4) | | DOCUMENT NO: 98ASH70029A | REV: F |
| | | STANDARD: JEDEC MS-026 BBA | |
| | | SOT358-3 | 01 APR 2016 |

9 Revision history

| Revision | Date | Description of Changes |
|----------|--------|--|
| 1.0 | 1/2015 | <ul style="list-style-type: none">Initial release |
| 2.0 | 2/2015 | <ul style="list-style-type: none">Minor corrections to form and style - No technical content changesChanged document status to Advance InformationChanged orderable part number from PC to MC. |
| 3.0 | 5/2016 | <ul style="list-style-type: none">Corrected definitions for pins 5, 6, 7, 8, and 24 in Table 2Updated document form and style |
| | 6/2016 | <ul style="list-style-type: none">Corrected the title of Table 9 |
| | 7/2016 | <ul style="list-style-type: none">Corrected address names in Table 8 |



How to Reach Us:

Home Page:

[NXP.com](http://www.nxp.com)

Web Support:

<http://www.nxp.com/support>

Information in this document is provided solely to enable system and software implementers to use NXP products. There are no expressed or implied copyright licenses granted hereunder to design or fabricate any integrated circuits based on the information in this document. NXP reserves the right to make changes without further notice to any products herein.

NXP makes no warranty, representation, or guarantee regarding the suitability of its products for any particular purpose, nor does NXP assume any liability arising out of the application or use of any product or circuit, and specifically disclaims any and all liability, including without limitation, consequential or incidental damages. "Typical" parameters that may be provided in NXP data sheets and/or specifications can and do vary in different applications, and actual performance may vary over time. All operating parameters, including "typicals," must be validated for each customer application by the customer's technical experts. NXP does not convey any license under its patent rights nor the rights of others. NXP sells products pursuant to standard terms and conditions of sale, which can be found at the following address:

<http://www.nxp.com/terms-of-use.html>.

NXP, the NXP logo, Freescale, the Freescale logo, SafeAssure, the SafeAssure logo, and SMARTMOS are trademarks of NXP B.V. All other product or service names are the property of their respective owners. All rights reserved.

© 2016 NXP B.V.

Document Number: MC33SA0528

Rev. 3.0

7/2016



X-ON Electronics

Largest Supplier of Electrical and Electronic Components

Click to view similar products for [Motor/Motion/Ignition Controllers & Drivers](#) category:

Click to view products by [NXP](#) manufacturer:

Other Similar products are found below :

[FSB50550TB2](#) [FSBF15CH60BTH](#) [MSVCPM2-63-12](#) [MSVGW45-14-2](#) [MSVGW54-14-3](#) [MSVGW54-14-5](#) [NTE7043](#) [LA6565VR-TLM-E](#)
[LB11650-E](#) [LB1837M-TLM-E](#) [LB1845DAZ-XE](#) [LC898300XA-MH](#) [SS30-TE-L-E](#) [26700](#) [BA5839FP-E2](#) [IRAM236-1067A](#) [LA6584JA-AH](#)
[LB11847L-E](#) [NCV70501DW002R2G](#) [AH293-PL-B](#) [STK672-630CN-E](#) [TND315S-TL-2H](#) [FNA23060](#) [FSB50250AB](#) [FNA41060](#) [MSVB54](#)
[MSVBTC50E](#) [MSVCPM3-54-12](#) [MSVCPM3-63-12](#) [MSVCPM4-63-12](#) [MSVTA120](#) [FSB50550AB](#) [NCV70501DW002G](#) [LC898301XA-MH](#)
[LV8413GP-TE-L-E](#) [MSVGW45-14-3](#) [MSVGW45-14-4](#) [MSVGW45-14-5](#) [MSVGW54-14-4](#) [STK984-091A-E](#) [MP6519GQ-Z](#) [LB11651-E](#)
[IRSM515-025DA4](#) [LV8127T-TLM-H](#) [MC33812EKR2](#) [NCP81382MNTXG](#) [TDA21801](#) [LB11851FA-BH](#) [NCV70627DQ001R2G](#)
[LB1938FAGEVB](#)