

Mini or Micro-USB Interface IC

The 34827 is a dedicated IC for managing charging and signal multiplexing between a cell phone and its accessory via a 5-pin Mini or Micro-USB connector. An external power source, such as a dedicated AC/DC adapter or a standard USB port, is able to charge the battery in the cell phone via the connector. The 34827 is capable of identifying the type of the external power source and selecting one of two battery charge current levels according to the type. The internal power switch can protect the phone system against 28 V power supply input. The 34827 is also able to multiplex the 5 pins to support UART and High-Speed USB 2.0 data communication, mono/stereo-audio/microphone headset with or without a cord remote control, manufacturing or R/D test cables and other accessories.

To identify what accessory is plugged into the Mini or Micro-USB connector, the 34827 supports various detection mechanisms, including the VBUS detection and ID detection. A high accurate 5-bit ADC is offered to distinguish the 32 levels of ID resistance and to identify the button pressed in a cord remote control while an Audio Type 1 cable is attached. After identifying the accessory attached, the 34827 configures itself to support the accessory and interrupts a host via an I²C serial bus for further actions. The 34827 is also able to identify some non-supported accessory, such as video cable, Phone-Powered Devices and USB OTG devices. The host controls the 34827 via the I²C serial bus. This device is powered using SMARTMOS technology.

Features

- Automatically identifies the power supply type and sets one of two battery-charge-current levels
- Internal power switch protects the phone system against 28 V power supply input
- Supports stereo/mono headset with or without micro phone and remote control
- Supports USB or UART test and R/D cables
- High speed USB2.0 compliant
- Supports 32 ID resistance values with a high-accuracy 5-bit ADC
- I²C interface with interrupt to the host
- 10 μA quiescent current in Standby mode

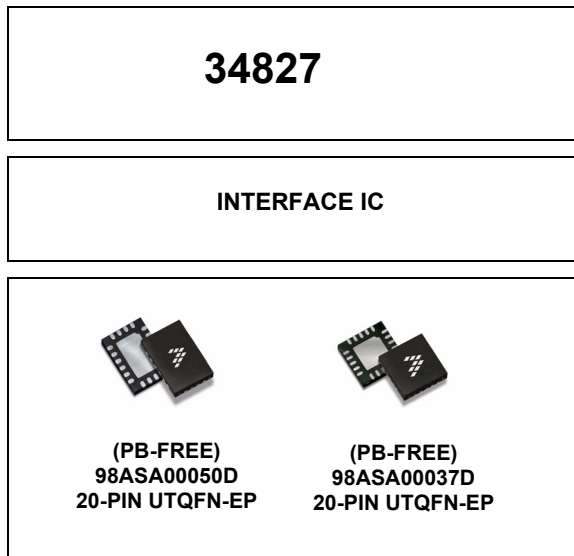

Applications

- Cell phones
- MP3/MP4 players
- Portable voice recorders
- USB universal charging solution (UCS-OMTP)
- Supports mini/micro - USB connector
- UART and USB high speed communication
- Remote control/accessories IDs

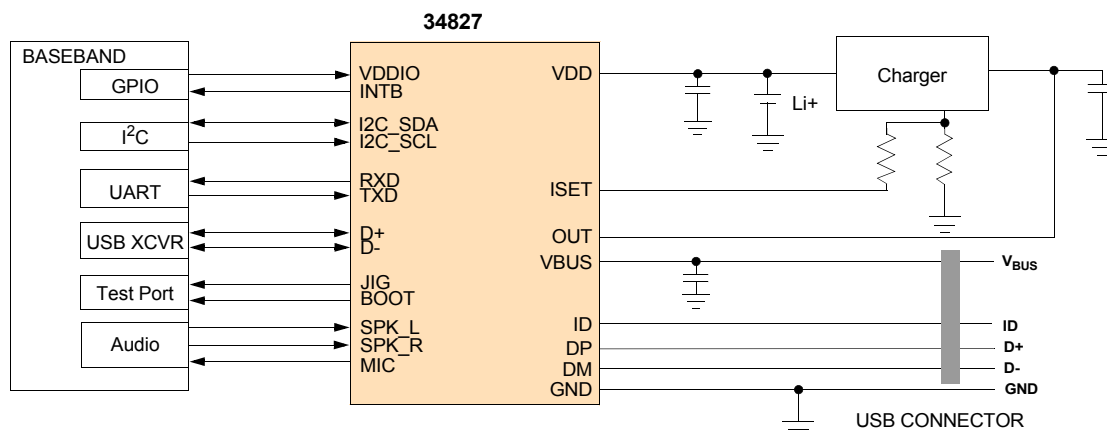

Figure 1. MC34827 Simplified Application Diagram

1 Orderable Parts

Table 1. Orderable Part Variations

Part Number ⁽¹⁾	Temperature (T _A)	Package
MC34827A2EP	-40 to 85 °C	3.0 mm X 4.0 mm UTQFN-EP
MC34827A1EP		3.0 mm X 3.0 mm UTQFN-EP

Notes

1. To order parts in Tape and Reel, add the R2 suffix to the part number.

INTERNAL BLOCK DIAGRAM

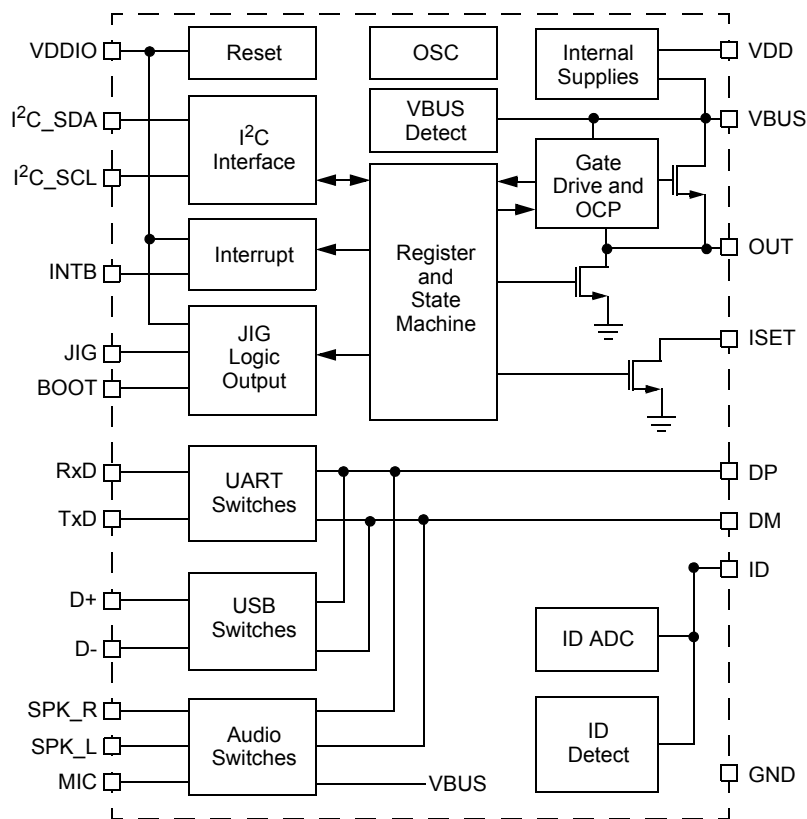
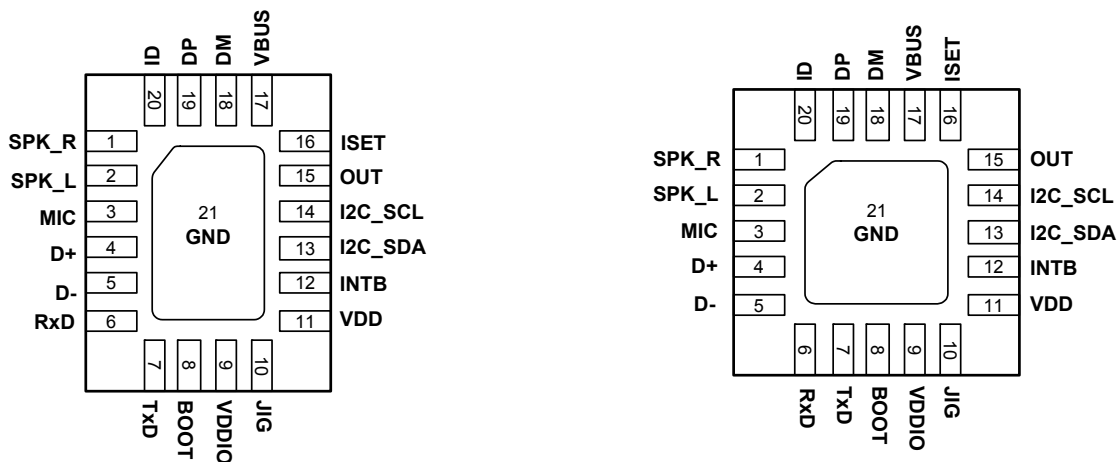

Figure 2. MC34827 Simplified Internal Block Diagram

PIN CONNECTIONS



(A). Pinout of 34827 Using a 3.0 mm X 4.0 mm 20 Pin. UTQFN Package (Transparent Top View)

(B). Pinout of 34827 Using a 3.0 mm X 3.0 mm 20 Pin. UTQFN Package (Transparent Top View)

Figure 3. MC34827 Pin Connections

Table 2. MC34827 Pin Definitions

A functional description of each pin can be found in the Functional Pin Description section beginning on [page 14](#).

Pin Number	Pin Name	Pin Function	Formal Name	Definition
1	SPK_R	Input	Speaker right channel	Right channel input of the speaker signals
2	SPK_L	Input	Speaker left channel	Left channel input of the speaker signals
3	MIC	Output	Microphone output	Microphone output to the baseband of the cell phone system
4	D+	IO	D+ of the USB transceiver	D+ line of the USB transceiver
5	D-	IO	D- of the USB transceiver	D- line of the USB transceiver
6	RxD	Output	UART receiver	Receive line of the UART
7	TxD	Input	UART transmitter	Transmit line of the UART
8	BOOT	Output	BOOT indicator	Push-pull output to indicate the boot switch setting of the jig cable
9	VDDIO	Input	IO power supply	IO supply voltage. This is the internal supply voltage for the BOOT and INTB outputs. It can supply the external pull-up voltages for the JIG pin and the I ² C bus outside the 34827. This pin also functions as the hardware reset to the IC.
10	JIG	Output	JIG indicator	Open-drain output to indicate the insertion of a jig cable
11	VDD	Input	Power supply	Supply input
12	INTB	Output	Interrupt output	Push-pull interrupt output
13	I2C_SDA	IO	I ² C Data	Data line of the I ² C interface
14	I2C_SCL	Input	I ² C Clock	Clock line of the I ² C interface
15	OUT	Output	Power output	The output of the power MOSFET pass switch
16	ISET	Output	Charge current setting	Open-drain output to set the charger current
17	VBUS	Input	VBUS power supply	Mini-USB VBUS line

Table 2. MC34827 Pin Definitions (continued)

A functional description of each pin can be found in the Functional Pin Description section beginning on [page 14](#).

Pin Number	Pin Name	Pin Function	Formal Name	Definition
18	DM	IO	D- of the USB connector	D- line of the mini-USB connector
19	DP	IO	D+ of the USB connector	D+ line of the mini-USB connector
20	ID	Input	ID of the USB connector	ID pin of the mini-USB connector
21	GND	Ground	Ground	Ground

ELECTRICAL CHARACTERISTICS

MAXIMUM RATINGS

Table 3. Maximum Ratings

All voltages are with respect to ground, unless otherwise noted. Exceeding these ratings may cause a malfunction or permanent damage to the device.

Ratings	Symbol	Value	Unit
ELECTRICAL RATINGS			
Input Voltage Range			V
VBUS Pin	V_{BUS}	-0.3 to 28	
OUT Pin	V_{OUT}	-0.3 to 8	
VDD Pin	V_{DD}	-0.3 to 6	
VDDIO Pin ⁽¹⁾	V_{DDIO}	-0.3 to 4.2	
SPK_L, SPK_R, DP and DM Pins		-2.0 to $V_{DD}+0.3$	
All Other Pins		-0.3 to 5.5	
ESD Voltage ⁽²⁾	V_{ESD}		V
Air Gap Discharge Model for VBUS, DP, DM, ID Pins ⁽³⁾		±15000	
Human Body Model (HBM) for VBUS, DP, DM, ID Pins		±8000	
Human Body Model (HBM) for all other pins		±2000	
Machine Model (MM)		±200	
THERMAL RATINGS			
Operating Temperature			°C
Ambient	T_A	-40 to +85	
Junction	T_J	150	
Storage Temperature	T_{STG}	-65 to +150	°C
Thermal Resistance ⁽⁴⁾			°C/W
Junction-to-Case	$R_{\theta JC}$	6	
Junction-to-Ambient	$R_{\theta JA}$	45	
Peak Package Reflow Temperature During Reflow ^{(5), (6)}	T_{PPRT}	Note 6	°C

Notes

- The VDDIO pin CANNOT exceed a maximum voltage of 4.2 V, else it will suffer permanent damage.
- ESD testing is performed in accordance with the Human Body Model (HBM) ($C_{ZAP} = 100$ pF, $R_{ZAP} = 1500$ Ω), and the Machine Model (MM) ($C_{ZAP} = 200$ pF, $R_{ZAP} = 0$ Ω).
- Need external ESD protection diode array to meet IEC1000-4-2 15000V air gap discharge requirement ($C_{ZAP} = 150$ pF, $R_{ZAP} = 330$ Ω).
- Device mounted on the Freescale EVB test board per JEDEC DESD51-2.
- Pin soldering temperature limit is for 10 seconds maximum duration. Not designed for immersion soldering. Exceeding these limits may cause malfunction or permanent damage to the device.
- Freescale's Package Reflow capability meets Pb-free requirements for JEDEC standard J-STD-020C. For Peak Package Reflow Temperature and Moisture Sensitivity Levels (MSL), go to www.freescale.com, search by part number, e.g. remove prefixes/suffixes and enter the core ID to view all orderable parts. (i.e. MC33xxxD enter 33xxx), and review parametrics.

STATIC ELECTRICAL CHARACTERISTICS

Table 4. Static Electrical Characteristics

Characteristics noted under conditions $V_{DD} = 3.6\text{ V}$, $V_{BUS} = 5.0\text{ V}$, $V_{DDIO} = 3.0\text{ V}$, $-40\text{ }^{\circ}\text{C} \leq T_A \leq 85\text{ }^{\circ}\text{C}$ (see [Figure 1](#)), unless otherwise noted. Typical values noted reflect the approximate parameter means at $V_{DD} = 3.6\text{ V}$ and $T_A = 25\text{ }^{\circ}\text{C}$ under nominal conditions, unless otherwise noted.

Characteristic	Symbol	Min	Typ	Max	Unit
POWER INPUT					
Recommended Operating Voltage Range for VDD Supply Voltage	V_{DD}	2.7	-	5.5	V
VDD Power-on Reset Threshold	V_{VDDPOR}	-	2.5	2.65	V
Rising edge		-	100	-	mV
Hysteresis		-	-	-	mV
VDD Quiescent Current	I_{VDD}	-	9.0	12	μA
In Standby mode		-	12	18	
In Power Save mode		-	125	160	
When accessory is attached & INT_MASK = '1'		-	550	650	
In Active mode ($V_{DD} < V_{BUS}$)		-	850	1000	
In Active mode ($V_{DD} > V_{BUS}$)		-	-	-	
VBUS Supply Voltage	V_{BUS}	2.8	5.0	28	V
VBUS Detection Threshold Voltage	V_{BUS_DET}	-	2.65	2.80	V
Rising edge		-	150	-	mV
Hysteresis		-	-	-	mV
VBUS Supply Quiescent Current	I_{VBUS}	-	-	1.2	mA
In VBUS power mode		-	-	1.2	mA
In Active mode - Dedicated Charger		-	-	0.5	μA
In Active mode - Audio or TTY ⁽⁷⁾ ($V_{BUS} < V_{DD}$)		-	-	-	
VBUS Over-voltage Protection Threshold	V_{BUS_OVP}	6.8	7.0	7.2	V
Rising edge		-	150	-	mV
Hysteresis		-	-	-	mV
VBUS Over-current Protection	I_{BUS_OCP}	1.2	1.8	2.2	A
Triggering threshold (at onset of OTP shutoff)		-	-	-	
Over-temperature Protection Threshold	T_{OTP}	115	130	145	$^{\circ}\text{C}$
Rising threshold		-	95	-	
Falling threshold		-	-	-	
VDDIO Supply Voltage	V_{DDIO}	1.65	-	3.6	V
SWITCH					
ISET Open-drain Output MOSFET					
On resistance (loaded by 3.0 mA current)	R_{ISET}	-	-	100	Ω
Leakage current (when the MOSFET is off at 5.0 V bias voltage)	I_{ISET_OFF}	-	-	0.5	μA
OUT Pin Discharge MOSFET ⁽¹⁶⁾					
On resistance (loaded by 3.0 mA current)	R_{OUT_DISC}	-	-	100	Ω
Leakage current (when the MOSFET is off at 5.0 V bias voltage)	I_{OUT_OFF}	-	0.5	-	μA

Notes

- This is an important specification because when an audio accessory is attached, the VBUS line is connected to the microphone. The quiescent current will affect the bias of the microphone.
- The OUT pin discharge MOSFET is shown in [Figure 20](#). This MOSFET will be turned on when the power MOSFET is off.

Table 4. Static Electrical Characteristics (continued)

Characteristics noted under conditions $V_{DD} = 3.6\text{ V}$, $V_{BUS} = 5.0\text{ V}$, $V_{DDIO} = 3.0\text{ V}$, $-40\text{ }^{\circ}\text{C} \leq T_A \leq 85\text{ }^{\circ}\text{C}$ (see [Figure 1](#)), unless otherwise noted. Typical values noted reflect the approximate parameter means at $V_{DD} = 3.6\text{ V}$ and $T_A = 25\text{ }^{\circ}\text{C}$ under nominal conditions, unless otherwise noted.

Characteristic	Symbol	Min	Typ	Max	Unit
Power MOSFET On resistance (when $V_{BUS} = 5.0\text{ V}$, $T_A < 50\text{ }^{\circ}\text{C}$)	R_{PSW}	-	200	250	$\text{m}\Omega$
SPK_L and SPK_R Switches On resistance (20 Hz to 470 kHz) Matching between channels On resistance flatness (from -1.2 V to 1.2 V)	R_{SPK_ON} R_{SPK_ONMCT} R_{SPK_ONFLT}	- - -	1.6 0.12 0.01	3.0 0.25 0.05	Ω
D+ and D- Switches On resistance (0.1 Hz to 240 MHz) Matching between channels On resistance flatness (from 0.0 V to 3.3 V)	R_{USB_ON} R_{USB_ONMCT} R_{USB_ONFLT}	- - -	- 0.1 0.02	5.0 0.5 0.1	Ω
RxD and TxD Switches On resistance On resistance flatness (from 0.0 V to 3.3 V)	R_{UART_ON} R_{UART_ONFLT}	- -	- -	60 5.0	Ω
MIC Switches On resistance (at below 2.3 V MIC bias voltage) On resistance flatness (from 1.8 V to 2.3 V)	R_{MIC_ON} R_{MIC_ONFLT}	- -	- -	100 5.0	Ω
Pull-down Resistors between SPK_L or SPK_R Pins to GND	R_{PD_AUDIO}	-	100	-	$\text{k}\Omega$
Signal Voltage Range SPK_L, SPK_R, D+, D-, RxD, TxD, MIC		-1.5 -0.3	- -	1.5 3.6	V
PSRR - From VDD (100 mVrms) to DP/DM Pins ⁽⁹⁾ 20 Hz to 20 kHz with 32/16 Ω load.	V_{A_PSRR}	-	-	-60	dB
Total Harmonic Distortion ⁽⁹⁾ 20 Hz to 20 kHz with 32/16 Ω load.	THD	-	-	0.05	%
Crosstalk between Two Channels ⁽⁹⁾ 20 Hz to 20 kHz with 32/16 Ω load.	V_{A_CT}	-	-	-50	dB
Off-Channel Isolation ⁽⁹⁾ Less than 1.0 MHz	V_{A_ISO}	-	-	-100	dB

POWER SUPPLY TYPE IDENTIFICATION

Data Source Voltage Loaded by 0~200 μA	V_{DAT_SRC}	0.5	0.6	0.7	V
Data Source Current	I_{DAT_SRC}	0	-	200	μA
Data Detect Voltage	V_{DAT_REF}	0.3	0.35	0.4	V
Car Kit Detect Voltage	V_{CR_REF}	0.8	0.9	1.0	V
Data Sink Current DM pin is biased between 0.15 to 3.6 V	I_{DAT_SINK}	65	100	135	μA
DP, DM Pin Capacitance	$C_{DP/DM}$	-	8.0	-	pF

Notes

9. Not tested. Guaranteed by design.

Table 4. Static Electrical Characteristics (continued)

Characteristics noted under conditions $V_{DD} = 3.6\text{ V}$, $V_{BUS} = 5.0\text{ V}$, $V_{DDIO} = 3.0\text{ V}$, $-40\text{ }^{\circ}\text{C} \leq T_A \leq 85\text{ }^{\circ}\text{C}$ (see [Figure 1](#)), unless otherwise noted. Typical values noted reflect the approximate parameter means at $V_{DD} = 3.6\text{ V}$ and $T_A = 25\text{ }^{\circ}\text{C}$ under nominal conditions, unless otherwise noted.

Characteristic	Symbol	Min	Typ	Max	Unit
DP, DM Pin Impedance All switches are off (Switch_Open = 0)	$R_{DP/DM}$	-	50	-	$M\Omega$

ID DETECTION

ID FLOAT Threshold Detection threshold	V_{FLOAT}	-	2.3	-	V
Pull-up Current Source When ADC Result is 1xxxx When ADC Result is 0xxxx	I_{ID}	1.9 30.4	2.0 32	2.1 33.6	μA
Video Cable Detection Detection current Detection voltage low threshold Detection voltage high threshold	I_{VCBL} V_{VCBL_L} V_{VCBL_H}	1.0 - -	1.2 50 118	1.4 - -	mA mV mV

LOGIC INPUT AND OUTPUT

VDDIO Logic Input Threshold Input LOW threshold Input HIGH threshold	V_{DDIO_IL} V_{DDIO_IH}	- 1.5	- -	0.5 -	V V
Push-Pull Logic Output (INTB and BOOT) Output HIGH level (loaded by 1.0 mA current) Output LOW level (loaded by 4.0 mA current)	V_{OH} V_{OL}	$0.7V_{DDIO}$ -	- -	- 0.4	V
Open-Drain Logic Output (JIG) Output LOW level (loaded by 4.0 mA current)	V_{JIGOL}	-	-	0.4	V

I²C INTERFACE

Low Voltage on I2C_SDA, I2C_SCL Inputs	V_{I2C_IL}	-0.2	-	$0.3V_{DDIO}$	V
High Voltage on I2C_SDA, I2C_SCL Inputs	V_{I2C_IH}	$0.7V_{DDIO}$	-	V_{DDIO}	V
Low Voltage on I2C_SDA Output	V_{I2C_OL}	-	-	0.4	V
Current Load when I2C_SDA Outputs Low Voltage	I_{I2C_OL}	0	-	4.0	mA
Leakage Current on I2C_SDA, I2C_SCL Outputs	I_{I2C_LEAK}	-1.0	-	1.0	μA
Input Capacitance of the I2C_SDA, I2C_SCL Pins ⁽¹⁰⁾	C_{I2CIN}	-	-	8.0	pF

Notes

10. Not tested. Guaranteed by design.

DYNAMIC ELECTRICAL CHARACTERISTICS

Table 5. Dynamic Electrical Characteristics

Characteristics noted under conditions $V_{DD} = 3.6\text{ V}$, $V_{BUS} = 5.0\text{ V}$, $V_{DDIO} = 3.0\text{ V}$, $-40\text{ }^{\circ}\text{C} \leq T_A \leq 85\text{ }^{\circ}\text{C}$ (see [Figure 1](#)), unless otherwise noted. Typical values noted reflect the approximate parameter means at $V_{DD} = 3.6\text{ V}$ and $T_A = 25\text{ }^{\circ}\text{C}$ under nominal conditions, unless otherwise noted.

Characteristic	Symbol	Min	Typ	Max	Unit
----------------	--------	-----	-----	-----	------

POWER ON AND OFF DELAY

VDD Power-on Reset Threshold					ms
VDD rising deglitch time	t_{D2}	7.0	8.5	10.2	
VDD falling deglitch time	$t_{VDDDGTT_F}$	1.7	2.5	3.5	
VBUS Detection Threshold Deglitch Time (for Both Rising and Falling Edges)	t_{VBUS_DET}	3.5	4.5	5.7	ms
VBUS Over-voltage Protection					μs
Protection delay ⁽¹¹⁾	t_{OVDP}	-	-	2.0	
Falling-edge deglitch time ⁽¹²⁾	$t_{OVDPDGT_F}$	-	25	-	
VBUS Over-temperature Protection					
MOSFET turning off speed when OTP occurs ⁽¹³⁾	t_{OTP_TO}	-	-	0.5	A/ μs
Deglitch time	t_{OTP_DGT}	-	15	-	μs

OSCILLATOR

Oscillation Frequency	f_{OSC}	88	100	112	kHz
-----------------------	-----------	----	-----	-----	-----

SWITCHING DELAY

$t_1 - t_0$ (td in Figure 17 , Default Value is TD = 0100)	t_d				ms
TD = 0000		-	100	-	
TD = 0001		-	200	-	
TD = 0010		-	300	-	
TD = 0011		-	400	-	
TD = 0100		-	500	-	
...		
TD = 1111		-	1600	-	
$t_2 - t_1$ (Figure 17)	t_{SW}	20	-	-	ms
$t_3 - t_2$ (Figure 17)	t_{SW}	20	-	-	ms
$t_4 - t_1$ (Figure 17)	t_{SW}	100	-	-	ms
$t_6 - t_3$ (Figure 17)	t_{SW}	100	-	-	ms

ID DETECTION

ID FLOAT Detection Deglitch Time	t_{ID_FLOAT}	-	20	-	ms
Video Cable Detection Time (Video Cable Detection Current Source On Time)	t_{VCBL}	-	20	-	ms

ADC

ADC Conversion Time	t_{CONV}	-	1.0	-	ms
---------------------	------------	---	-----	---	----

Notes

11. The protection delay is defined as the interval between VBUS voltage rising above the OVP rising threshold, and the OUT pin voltage dropping below the OVP rising threshold voltage for a VBUS ramp rate of $>1.0\text{ V}/\mu\text{s}$.
12. The OVP deglitch timer is only for the falling edge threshold.
13. Not tested. Guaranteed by design.

Table 5. Dynamic Electrical Characteristics

Characteristics noted under conditions $V_{DD} = 3.6\text{ V}$, $V_{BUS} = 5.0\text{ V}$, $V_{DDIO} = 3.0\text{ V}$, $-40\text{ }^{\circ}\text{C} \leq T_A \leq 85\text{ }^{\circ}\text{C}$ (see [Figure 1](#)), unless otherwise noted. Typical values noted reflect the approximate parameter means at $V_{DD} = 3.6\text{ V}$ and $T_A = 25\text{ }^{\circ}\text{C}$ under nominal conditions, unless otherwise noted.

Characteristic	Symbol	Min	Typ	Max	Unit
----------------	--------	-----	-----	-----	------

REMOTE CONTROL

Key Press Comparator Debounce Time	t_{RMTCON_DG}	-	20	-	ms
------------------------------------	------------------	---	----	---	----

RESET TIMING

Device Reset Time	t_{RSTDVC}	-	10	-	μs
VDDIO Logic Input Timing					μs
Rising-edge deglitch time	$t_{VDDIODGT_R}$	660	875	1130	
Falling-edge deglitch time	$t_{VDDIODGT_F}$	105	125	150	
VDDIO Reset Timing					μs
VDDIO reset pulse width	$t_{RSTVDDIO}$	150	-	-	
I ² C Reset Timing					ms
I ² C reset pulse width	t_{RSTI2C}	13.5	-	-	
I ² C_SDA/I ² C_SCL concurrent low time without causing reset	$t_{NRSTI2C}$	-	-	8.8	

I²C INTERFACE⁽¹⁴⁾

SCL Clock Frequency	f_{SCL}	-	-	400	kHz
Bus Free Time between a STOP and START Condition	t_{BUF}	1.3	-	-	μs
Hold Time Repeated START Condition	$t_{HD:STA}$	0.6	-	-	μs
Low Period of SCL Clock	t_{LOW}	1.3	-	-	μs
High Period of SCL Clock	t_{HIGH}	0.6	-	-	μs
Setup Time for a Repeated START condition	$t_{SU:STA}$	0.6	-	-	μs
Data Hold Time	$t_{HD:DAT}$	0	-	-	μs
Data Setup Time	$t_{SU:DAT}$	120	-	-	ns
Rising Time of Both SDA and SCL Signals	t_R	$20+0.1C_B$	-	-	ns
Falling Time of Both SDA and SCL Signals	t_F	$20+0.1C_B$	-	-	ns
Setup Time for STOP Condition	$t_{SU:STO}$	0.6	-	-	μs
Input Deglitch Time (for Both Rising and Falling Edges)	t_{DGT}	55	-	300	ns

Notes

14. Not tested. Guaranteed by design.

ELECTRICAL PERFORMANCE CURVES

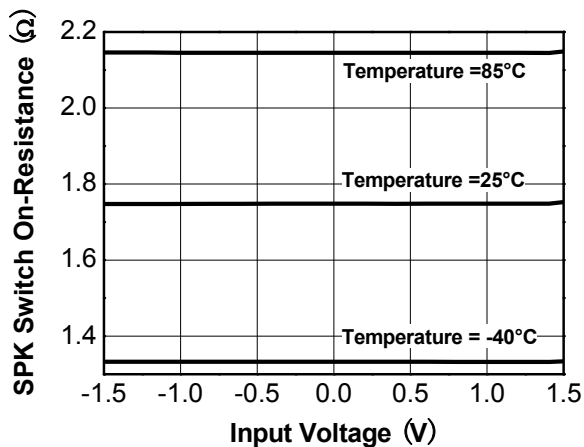

Figure 4. SPK Switch On-resistance vs Input Voltage

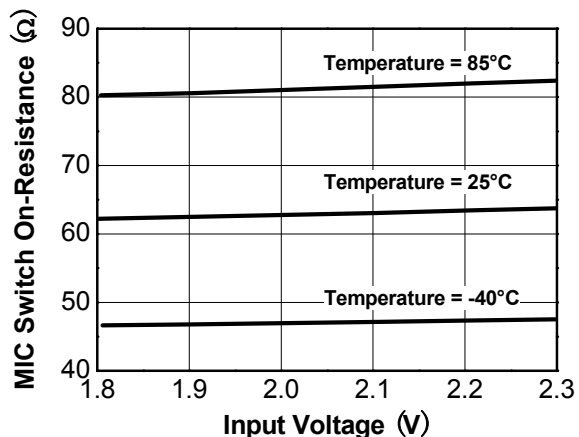

Figure 7. MIC Switch On-resistance vs Input Voltage

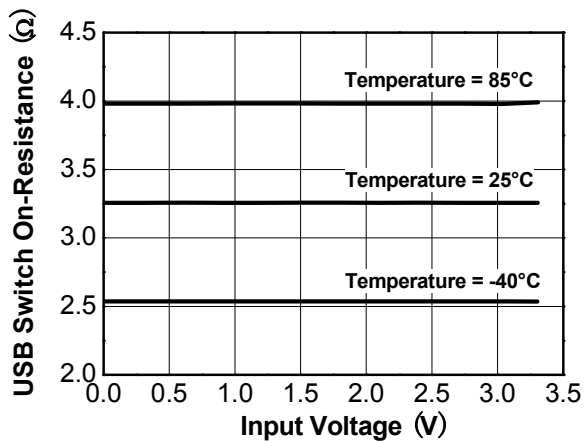

Figure 5. USB Switch On-resistance vs Input Voltage

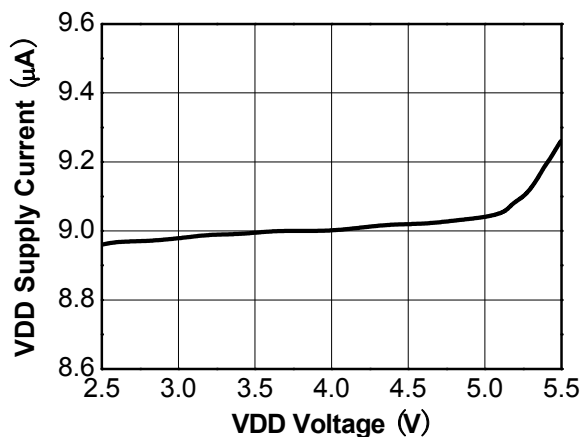

Figure 8. VDD Supply Current vs Supply Voltage in Standby Mode

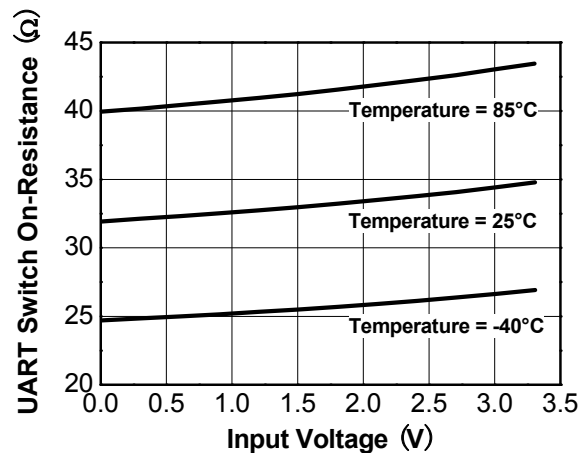

Figure 6. UART Switch On-resistance vs Input Voltage

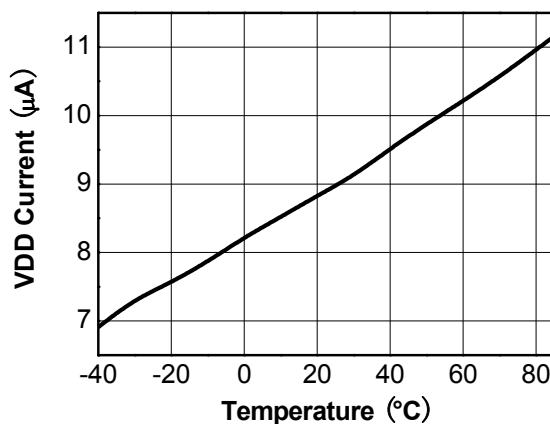

Figure 9. VDD Supply Current vs Temperature in Standby Mode

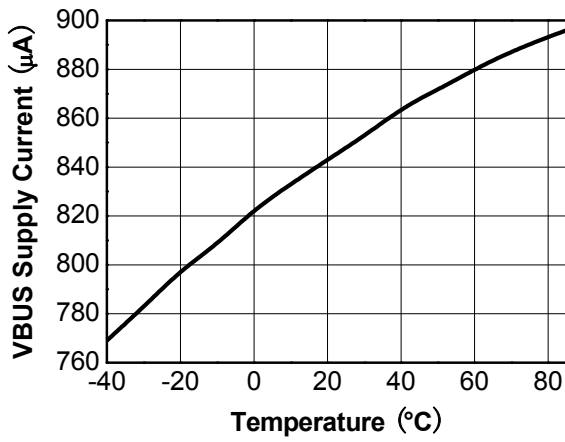

Figure 10. VBUS Supply Current vs Temperature In VBUS Power Mode

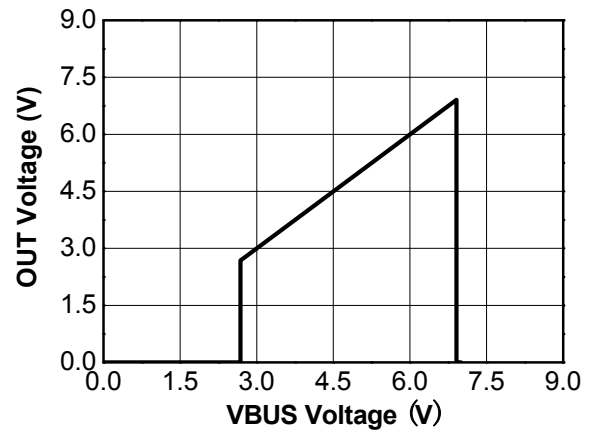

Figure 11. OUT Voltage vs VBUS Voltage

FUNCTIONAL DESCRIPTION

INTRODUCTION

The 34827 is used to identify what is attached to the Mini or Micro-USB connector, configure the signal paths between the phone baseband and the 5-pin connector accordingly, and then inform the baseband of the attachment. It also detects the detachment of accessory and then informs the baseband.

To identify what is plugged into the Mini or Micro-USB connector, the 34827 supports various detection mechanisms, including ID detection and VBUS detection. The detection flow is initiated either by the change of VBUS pin voltage or by the change of ID pin voltage. A high accurate 5-bit ADC is offered to distinguish the 32 levels of ID

resistance. Each level of resistance can be assigned to an accessory or a button in a cord remote controller. Some non-supported accessories, such as video cable, Phone-Powered Devices, USB OTG devices and so on, can also be identified. For 34827, the mapping relationship between the ADC values and the types of accessories is fixed and the detailed information is given in section [Application Information](#).

The detachment of accessory is also monitored by both of the ID detector and the VBUS detector.

The host IC can control the 34827 via an I²C serial bus.

FUNCTIONAL PIN DESCRIPTION

SPEAKER RIGHT CHANNEL (SPK_R)

Right channel of the baseband speaker output.

SPEAKER LEFT CHANNEL (SPK_L)

Left channel of the baseband speaker output.

MICROPHONE OUTPUT (MIC)

Microphone output to the baseband.

D+ OF THE USB TRANSCEIVER (D+)

D+ line of the USB transceiver.

D- OF THE USB TRANSCEIVER (D-)

D- line of the USB transceiver.

UART RECEIVER (RXD)

Receiver line of the UART.

UART TRANSMITTER (TXD)

Transmitter line of the UART.

BOOT INDICATOR (BOOT)

VDDIO referenced push-pull output to indicate the boot switch setting of jig cables.

IO POWER SUPPLY (VDDIO)

Power supply input for the logic IO interface. Generally the IO power supply voltage should be the same as the IO voltage used in the cell phone system. VDDIO is also one of hardware reset input sources. A falling edge at this pin will reset the 34827.

JIG INDICATOR (JIG)

Open-drain output to indicate the insertion of a jig cable.

POWER SUPPLY (VDD)

Power supply input. Bypass to ground with a 1.0 μ F capacitor.

INTERRUPT OUTPUT (INTB)

Active low and VDDIO referenced push-pull output. When the 34827 detects a change of external cable status, this pin outputs low voltage to interrupt the baseband. INTB returns to high voltage once all the interrupt bits are read.

DATA LINE OF THE I²C INTERFACE (I2C_SDA)

Data line of the I²C interface. I2C_SDA together with I2C_SCL is one of hardware reset input sources.

CLOCK LINE OF THE I²C INTERFACE (I2C_SCL)

Clock line of the I²C interface. I2C_SCL together with I2C_SDA is one of hardware reset input sources.

POWER OUTPUT (OUT)

Output of the power MOSFET in the 34827. This pin is connected to a charger. Bypass to ground with a 1.0 μ F capacitor.

CHARGE CURRENT SETTING (ISET)

Open-drain output to set the charge current for a charger according to the VBUS power supply type.

VBUS POWER SUPPLY (VBUS)

Mini-USB VBUS input. Bypass this pin to ground with a less than 10nF capacitor. When the attached accessory is an audio kit, this pin is the microphone input to the 34827.

D- OF THE USB CONNECTOR (DM)

D- line of the mini-USB connector.

D+ OF THE USB CONNECTOR (DP)

D+ line of the mini-USB connector.

ID OF THE USB CONNECTOR (ID)

ID pin of the mini-USB connector.

GROUND (GND)

Ground.

FUNCTIONAL INTERNAL BLOCK DESCRIPTION

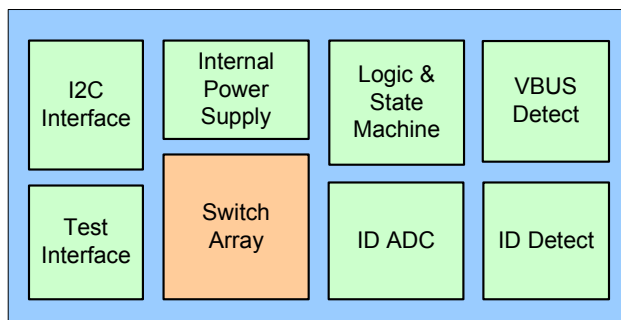

Figure 12. MC34827 Functional Internal Block Diagram

LOGIC AND STATE MACHINE

Internal state machine executes the detection and identification flow and turns on or off the signal switches according to the identification result.

I²C INTERFACE

I²C interface circuit is an I²C slave device. It receives commands and data from an I²C master device and transfers them to internal registers of 34827. It also transfers the data from the registers of 34827 to the I²C master device.

TEST INTERFACE

Test interface connects to a test block of the baseband.

SWITCH ARRAY

Switch array consist of switches for UART, USB and audio signal channels.

INTERNAL POWER SUPPLY

This block outputs power supply for the internal digital IO interface and also outputs high power supply for all internal blocks and for the external battery charger. The input power supplies of the block include VBUS, VDD and VDDIO.

VBUS DETECT

This block detects whether the power supply at VBUS pin is present.

ID ADC

An internal 5-bit ADC measures the resistance at the ID pin. The result is sent to the Logic and State Machine block to determine what accessory is attached.

ID DETECT

This block generates current sources and other signals to the ID pin to help the ID ADC block measure the ID resistance.

FUNCTIONAL DEVICE OPERATION

OPERATIONAL MODES

According to the status of the VBUS and VDD power supplies, the 34827 has five operational modes: Power Down mode, VBUS Power mode, Standby mode, Active mode, and

Power Save mode. The mode-transition diagram is given in [Figure 13](#). Details about the mode-transition conditions can be found in [Figure 14](#).

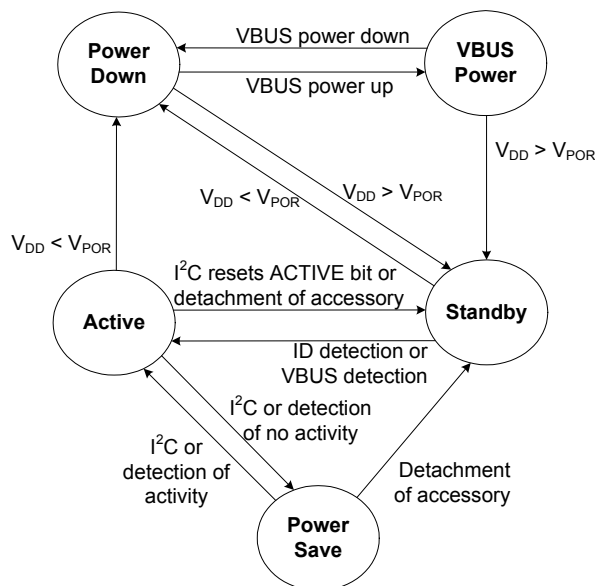

Figure 13. Mode Transition Diagram

POWER DOWN MODE

The Power Down mode is when neither the VDD nor the VBUS is powered. In this mode, the IC does not respond to any accessory attachment except for a power supply. When an external power supply is plugged, the 34827 enters the VBUS Power mode.

VBUS POWER MODE

34827 enters the VBUS Power mode when VBUS is powered but VDD is not. The 34827 supports regular USB port, dedicated charger, USB charger, 5 wire charger, charger on the A/V cable and any other accessory with powered VBUS voltage. In VBUS Power mode, the internal power MOSFET is turned on to power the charger IC, charging the battery in the phone. ISET pin outputs high impedance to select a lower charge current level for the charger IC.

STANDBY MODE

The Standby mode is when the VDD voltage is higher than the POR (Power-On Reset) threshold and no accessory is attached. In this mode only ID detection circuit, I²C interface, and internal registers are powered in order to minimize the quiescent current of VDD. The ID detection circuit samples the status of ID line in a period which can be programmed by

the Device Wake Up bits in Timing Set 1 register (refer to [Register Map](#) section for more register information).

In Standby mode, all signal switches and the power MOSFET are turned off. The ISET, JIG pins output high impedance and BOOT pin outputs low logic voltage.

If detecting an accessory attachment, the 34827 moves to the Active mode for further accessory identification.

ACTIVE MODE

The Active mode starts when an accessory is plugged with VDD powered. The 34827 identifies the accessory, configures the signal paths according to the identification result and interrupts the baseband for further actions. Different functions will be enabled according to the identification result. The quiescent current of VDD in Active mode is dependent on the type of attached accessory. The signal switches can also be turned on manually. See more information in section [Control Functions](#).

Mode can be changed from Active to Standby either by accessory detachment or by I²C programming.

POWER SAVE MODE

The Power Save mode is contributing only for the accessory of Audio Type 1 or TTY. The 34827 enters into

Power Save mode to minimize the operating current when Audio Type 1 or TTY accessory is attached but not used. For example, when the Audio Type 1 accessory is attached and the cell phone is not in audio playing mode, the baseband can move the 34827 to the Power Save mode via the I²C programming. The 34827 can also automatically switch to Power Save mode when no activity is detected on the SPK_R or SPK_L pins for a period which can be programmed by the Activity Idle Detection Time bits in Timing Set 1 register. The power consumption in Power Save mode approximates that in Standby mode.

The 34827 can quit the Power Save mode to Active mode by I²C programming or automatically when detecting signal activity. The configuration of the 34827 before switching to the Power Save mode is resumed. The mode can also be changed from Power Save mode directly to Standby mode due to the accessory detachment.

DEVICE MODE REGISTER

The PSAVE bit, ACTIVE bit and RST bit in Device Mode register hold the information of the device operational mode. The RST bit, which is of R/C type, indicates whether a reset has occurred. The RST is set when a Power-on Reset of

VDD, or a hardware reset of VDDIO input, or a hardware reset of I²C inputs occurs, and it will be cleared when it is read by I²C. The ACTIVE bit and the PSAVE bit together indicate the device mode according to the relationship shown in [Table 6](#). When the device is in VBUS Power mode, registers are not powered up.

The ACTIVE bit and PSAVE bit are of R/W type. The baseband can move the device mode to Standby mode manually by writing 0x00 to the Device Mode register via I²C. If an accessory is still attached during the operation, the accessory identification flow shown in [Figure 14](#) can be re-started.

Table 6. The Device Modes vs. the Register Bits

PSAVE	ACTIVE	MODE
0	0	Standby
0	1	Active
1	1	Power Save
1	0	Undefined

POWER-UP

The 34827 has four possible power-up scenarios depending on which of the VDD and the VBUS is powered first. The four scenarios correspond to the following four mode transitions (refer to [Figure 14](#)):

- From Power Down to VBUS Power:** VBUS is powered up when $V_{VDD} < V_{VDDPOR}$ (VDD POR threshold)
- From VBUS Power to Standby:** VBUS is already powered when the VDD rises above its POR threshold
- From Power Down to Standby:** VDD is powered up when $V_{VBUS} < V_{VBUSPOR}$ (VBUS POR threshold)
- From Standby to Active:** VDD is already powered when VBUS rises above its POR threshold

SCENARIO 1: VDD = 0 V AND VBUS IS POWERED UP (POWER DOWN MODE TO VBUS POWER MODE TRANSITION)

If VDD is not powered but the VBUS is powered up to a voltage range between the POR threshold and the OVP threshold, the internal charge pump for the power MOSFET gate driver starts to operate, softly turning on the power MOSFET. The IC is in the VBUS Power mode.

In this case, the ISET outputs high-impedance, all registers are in reset states.

SCENARIO 2: VBUS = HIGH AND VDD IS POWERED UP (VBUS POWER MODE TO STANDBY MODE TRANSITION)

If the VBUS is already powered up, when VDD is powered, the device moves from the VBUS Power mode to the Standby mode and then quickly move to the VBUS detection flow of the Active mode to identify the accessory, as shown in [Figure 14](#).

After VDD is powered up, the 34827 starts up the internal supplies. The POR resets all register bits. The power MOSFET remains on during the reset process.

SCENARIO 3: VBUS = 0 V AND VDD IS POWERED UP (POWER DOWN MODE TO STANDBY MODE TRANSITION)

If no accessory is plugged, when VDD is powered, the 34827 moves from the Power Down mode to the Standby mode. The internal supplies are started up first, and then the whole chip is reset and is ready to accept accessories. When an accessory is attached, the 34827 enters the Active mode. The power MOSFET is off in this case since $VBUS = 0 V$.

SCENARIO 4: VDD = HIGH AND VBUS IS POWERED UP (STANDBY TO ACTIVE MODE TRANSITION)

This is a normal VBUS detection case.

ACCESSORY IDENTIFICATION

The identification flow chart is shown in [Figure 14](#).

When an accessory with powered VBUS is attached in Power Down mode, the 34827 enters VBUS Power mode. The 34827 will not identify the type of accessory in VBUS Power mode. The ISET pin outputs high-impedance for all accessories, and the power MOSFET is turned on to pass the VBUS voltage to the charger IC to charge the battery. Once the VDD is increased above the POR threshold, the 34827 enters Standby mode to start the identification flow

In the Standby mode, the 34827 monitors both the ID pin and the VBUS pin. If an accessory attachment is detected, the 34827 enters Active mode to start the identification flow. The ID detection state machine will find out what ID resistor is attached and the PSTI circuit will find out what type of power supplies is connected.

An identification conclusion can be drawn when the identification flow is finished. The corresponding bit in the Device Type register is set to indicate the device type, and the ATTACH bit in the Interrupt 1 register is set to inform the

baseband; If the attached accessory can't be identified, the Unknown_Atta bit in the Interrupt 2 register will be set.

According to the automatic configuration capability of the 34827 in Active mode, there are three types of accessories:

1. Recognized and supported. Such accessories include: USB port, Dedicated charger, USB charger, A/V charger, 5-wire type 1 and 5-wire type 2 chargers, UART, Audio Type 1 cable, TTY accessory, USB jig cable and UART jig cable. Automatic configurations are supported for those accessories.
2. Recognized but not supported. These accessories can be identified but not supported by 34827, including A/V cable, Phone-Powered Devices, USB OTG accessories and Audio Type 2 cable.
3. Not recognized accessories. These will be identified as Unknown accessories.

The details on the identification flow in Active mode are described as following.

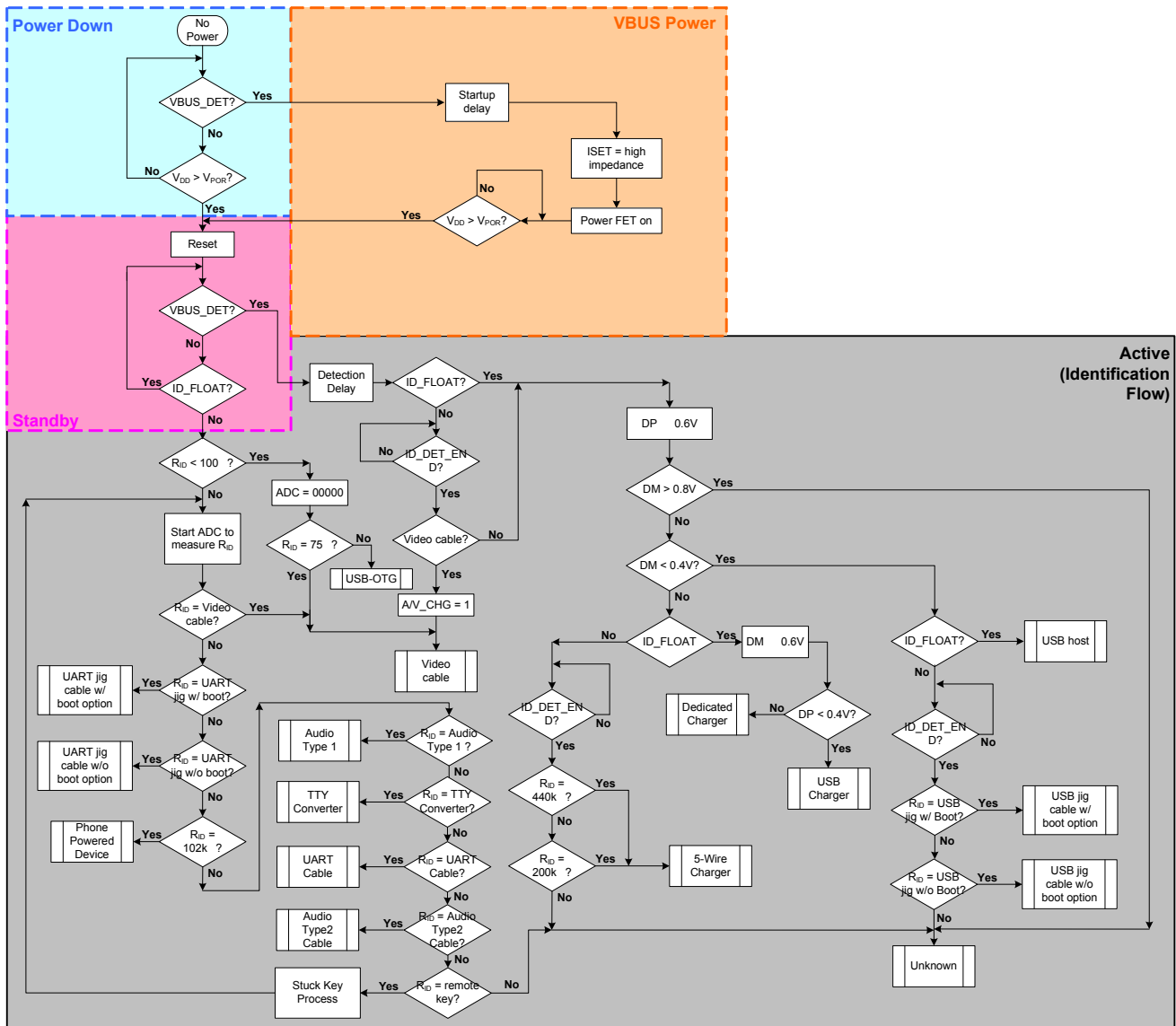

Figure 14. Detailed Accessory Identification Flow Diagram

RID IDENTIFICATION

A comparator monitors the ID pin impedance to ground. When a resistor less than 1.0 MΩ is connected between the ID line and the ground, the ID_FLOAT bit in the FSL Status 1 register will be set to 0; when the resistor is removed, ID_FLOAT bit will be set to 1. A falling-edge of this bit starts the identification flow and a rising-edge of this bit starts the detachment detection flow.

A signal, ID_DET_END, is used to indicate the end of the identification.

ID ADC

After the ID_FLOAT bit is set to 0, the identification flow is started, and an ADC_EN signal is set to enable an ADC conversion. A 5-bit ID ADC is used to measure the ID

resistance. The ADC is also used to identify what button is pressed in a cord remote control when the attached accessory is Audio Type 1 cable. The ADC allows 32 levels for the ID resistance measurement and can accurately convert a 1% resistor value to a 5-bit result. The ADC outputs vs. ID resistor values are given in [Table 7](#).

When the conversion completes, an ADC_STATUS bit is set and the ADC result value is sent to the ADC Result register. The ADC_EN signal is cleared automatically after the conversion finishes.

If the ID resistance is below 2.0 kΩ, the ADC Result is set to 00000. If the ID line is floating, the ADC Result is set to 11111.

STUCK KEY IDENTIFICATION

When the ADC conversion is finished and the ADC Result is found to be a value corresponding to a remote control key of Audio Type 1 cable, a stuck key process flow will be initiated to find out whether a remote control key is stuck and to inform the baseband of the stuck key status.

Figure 15 shows the stuck key process flow. If the stuck key is detected to be released within 1.5 s, the flow will return to re-start the ID identification flow; Otherwise, a Stuck_Key Interrupt will be set. When the key is released, a Stuck_Key_RCV Interrupt will be generated and then the identification flow will be re-started to find out the ID resistance of the attached cable.

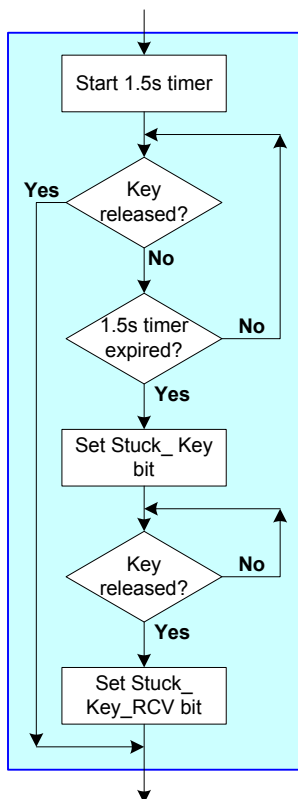

Figure 15. The Stuck Key Process Flow Diagram

Table 7. ADC Output vs. Resistor Values (Unit: kΩ)

ADC Result	R _{ID} (kΩ)	ADC Result	R _{ID} (kΩ)	ADC Result	R _{ID} (kΩ)	ADC Result	R _{ID} (kΩ)
00000	(15)	01000	10.03	10000	40.2	11000	255
00001	2.00	01001	12.03	10001	49.9	11001	301
00010	2.604	01010	14.46	10010	64.9	11010	365
00011	3.208	01011	17.26	10011	80.07	11011	442
00100	4.014	01100	20.5	10100	102	11100	523
00101	4.820	01101	24.07	10101	121	11101	619
00110	6.03	01110	28.7	10110	150	11110	1000
00111	8.03	01111	34.0	10111	200	11111	(16)

Notes:

15. If the ID resistance is below 1.9 kΩ, the ADC Result is set to 00000.
16. If the ID line is floating, the ADC Result is set to 11111

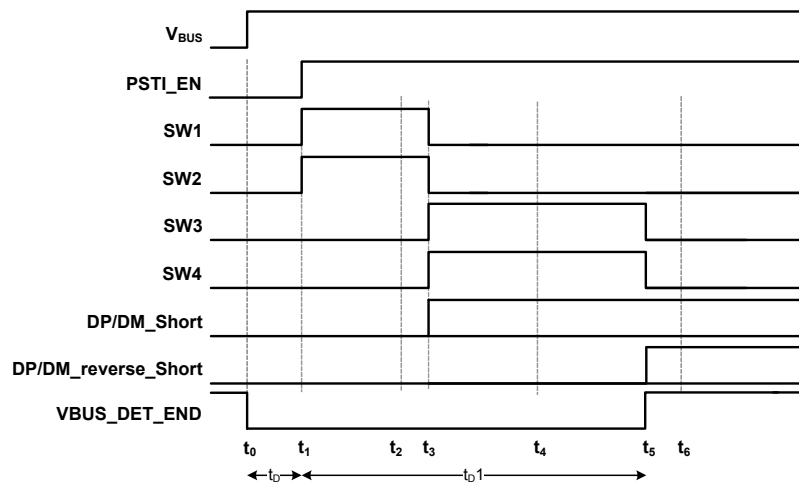

Figure 17. Operating Waveforms for the PSTI Circuit

OPERATION AFTER IDENTIFICATION

The identification process is started when VDD is above POR and the accessory attachment is detected. After the identification process is finished, the operation of the 34827 is determined together by the type of accessory, that is JIG cable or non-JIG cable, the status of power supplies, including the VBUS, VDD and VDDIO, and the Control register values.

If VBUS is powered up and VDD and VDDIO are low, the identification flow is not started. The 34827 is in the VBUS Power mode. The power MOSFET is on and ISET outputs high impedance. The JIG pin outputs high impedance, and the BOOT pin outputs logic low voltage for all accessories.

When VDD increases above POR but VDDIO is still low, the identification flow is started. But the interrupt mask control bit INT_MASK in Control register is in reset state ('1') to mask all interrupt outputs. All signal switches are off no matter what

type of accessory is attached. This condition happens when the cell phone is not powered up yet. In this condition, if the accessory is found to be a JIG cable, the JIG pin outputs low impedance to enable the PMIC in the cell phone. Then VDDIO rises. Once the VDDIO rises to high, the BOOT pin will output the correct logic voltage and the UART or the USB switches will be turned on according to the type of JIG cable.

When the VDDIO is started up, the INT_MASK bit is still in reset state '1', and the INTB output stays low. If the accessory is not a JIG cable, when the VDD and VDDIO are both powered up, the signal switches remains off until the INT_MASK is written to '0' by I²C.

The behaviors of INTB and signal switches during such transition and other important control functions are described below in detail.

CONTROL FUNCTIONS

The 34827 contains registers which hold control and status information. The register map and the description of each register can be found in [Register Map](#) section. The details about some important control bits are described as follows.

INTERRUPT MASK (INT_MASK)

The INT_MASK bit masks all interrupt outputs to the host. When the INT_MASK bit is '1', the INTB output is forced to low, and the corresponding interrupt bit can be still set when an interrupt event happens, but the host should not read the interrupt registers when INT_MASK = 1. When INT_MASK bit is set to '0', the INTB output is allowed to send an interrupt, if any, to the host after a delay as shown in [Figure 18](#). The delay is a WAIT time programmed by the Switching Wait bits in Timing Set 2 register. During the delay time, the INTB

outputs a high voltage, and the host is not allowed to read the interrupt registers.

[Figure 18](#) illustrates the switching behavior when the INT_MASK is set to '0'. Figure (A) shows the case that no interrupt bit is already set. In this case, the INTB outputs high when INT_MASK bit is set to zero. Figure (B) shows the case that an interrupt bit is already set due to attachment of an accessory and WAIT = 1 when the first delay time expires. In this case, INTB outputs high voltage during the first delay time and then outputs low voltage when the delay time expires. Once the INTB outputs low voltage after the delay time, the 34827 waits for a second WAIT time before turning on the signal switches. The baseband should read the interrupt registers via the I²C, and since all the interrupt bits are of R/C type, the interrupt bits will be cleared after being read and then the INTB output returns to high. Figure (C)

shows the case that an interrupt bit is already set due to attachment of an accessory and WAIT = 0 when the first delay time expires. In this case, INTB outputs high voltage in the first delay time and then outputs low voltage after the first

delay time expires. The signal switches are not turned on until the WAIT bit is written to '1' by I²C. When the baseband reads the interrupt registers via the I²C, the interrupt bits are cleared and the INTB output returns to high.

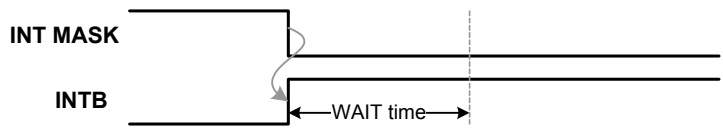

(A). No accessory attached when the INT_MASK is reset to zero

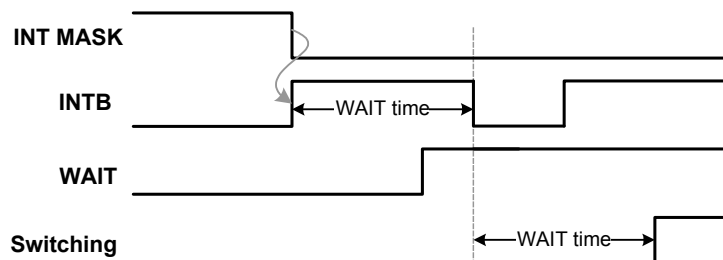

(B). An accessory is already attached when the INT_MASK is reset to zero and WAIT bit = 1 when the first wait time expires.

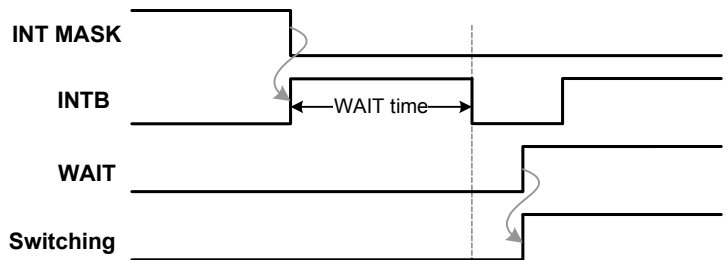

(C). An accessory is already attached when the INT_MASK is reset to zero and the WAIT bit = 0 when the first wait time expires.

Figure 18. Operating Waveforms of the INT_MASK Bit

TIMING OF THE SWITCHING ACTION (WAIT BIT)

If the INT_MASK bit is already set to '0' before an accessory is attached, the INTB outputs low voltage once an interrupt bit is set and the following timing of the switching action is controlled by the WAIT bit in the Control register. If the WAIT bit is '1' when the Attach interrupt bit is set and INTB outputs low voltage, the 34827 waits for a WAIT time

before turning on the switches. The WAIT time is programmed by the Switching Wait bits in the Timing Set 2 register. If the WAIT bit is '0' when the Attach interrupt is generated, the 34827 will not turn on the switches until the WAIT bit is set to '1' by I²C. Both cases are shown in the [Figure 19](#).

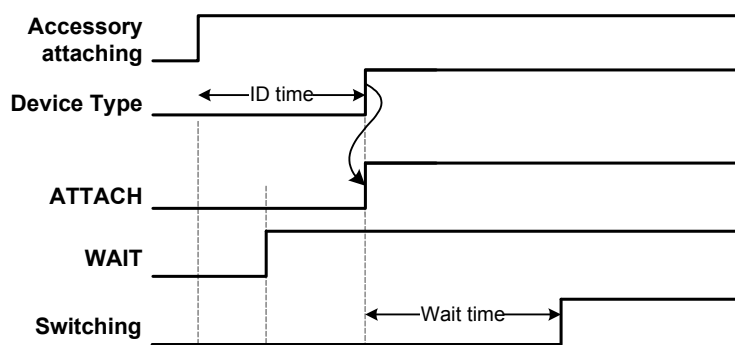

(A). WAIT = 1 when the ATTACH interrupt is generated. (VDDIO is high and INT_MASK = 1.)

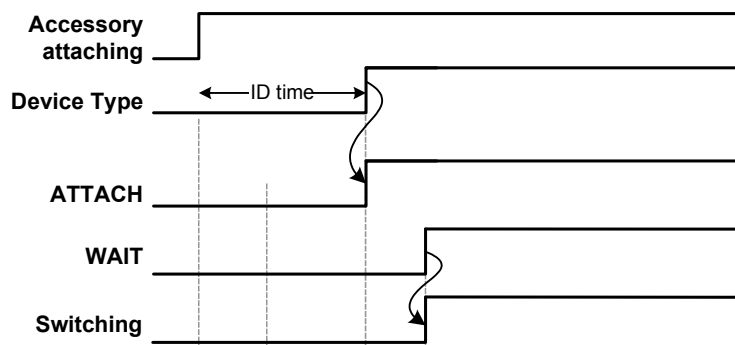

(B). WAIT = 0 when the ATTACH interrupt is generated. (VDDIO is high and INT_MASK = 1.)

Figure 19. Operating Waveforms of the WAIT Bit

AUTOMATIC SWITCHING OR MANUAL SWITCHING (SWITCH_OPEN & MANUAL S/W BITS)

When a supported accessory is identified, the default behavior of 34827 is to automatically turn on the corresponding signal switches. The user can also choose to turn on optional signal switches manually. How to turn on the switches is controlled by the Manual S/W bit and the Switch_Open bits in the Control register.

If the Switch_Open bit is '0', all switches are off, including the power MOSFET.

If Manual S/W = 1, which is its reset value, the switches to be turned on and the outputs of ISET, JIG and BOOT pins are determined automatically by the Device Mode register, that is the identification result. If Manual S/W = 0, the switches to be turned on and the outputs of ISET, JIG and BOOT pins are determined by the values of the Manual S/W register. The relationship between the values of the Manual S/W register and the switches to be turned on can be found in [Register Map](#) section.

The values of Switch_Open and Manual S/W bits will not affect the identification flow and the timing of signal switching action of the 34827. The difference between Manual S/W = 1 and Manual S/W = 0 is what switches are turned on and what the ISET, JIG and BOOT pins output when an accessory is attached. In both way, no switches are turned on in Standby

mode. If the Manual S/W bit is changed from '1' to '0' while an accessory is attached, the already automatically turned on switches will be turned off, the switches selected manually will be turned on, and the status of the ISET, JIG and BOOT pins will be determined by the corresponding bit value in the Manual S/W 2 register. However, writing Manual S/W bit back to '1' in Active mode will not change the switches status and the outputs.

RAW DATA (RAW DATA BIT)

The RAW DATA bit functions only when the accessory is Audio Type 1, which supports the remote control key. The RAW DATA bit determines whether to report the ID pin resistance change to the baseband when any key is pressed. When RAW DATA = 1, the ADC is enabled only when an ID line event is detected, such as when a key is pressed. In this case, the interrupt bits KP, LKP or LKR and the corresponding button bits in Button 1 and Button 2 registers will be set accordingly. Detailed behavior information when RAW DATA = 1 can be found in section [Audio Device Type 1 -- Audio with or without the Remote Control](#). When RAW DATA = 0, the ADC is enabled periodically to calculate the ID line resistance. Any change of ADC Result will set the ADC_Change interrupt bit to inform the baseband. Then the baseband can read the ADC Result via I²C. The KP, LKP or LKR and the button bits will not set when RAW DATA = 0.

The period of ADC conversion is determined by the Device Wake-up bits in the Timing Set 1 register. All other behaviors of Audio Type 1 and other accessories will not be affected by the RAW DATA bit.

POWER SAVE MODE (AUTOSAVE BIT)

The 34827 supports the Power Save mode when the accessory is Audio Type 1 or TTY to reduce the power consumption. The default behavior of 34827 is to enter the Power Save mode automatically if no signal activity is detected within a programmable time which is controlled by the Activity Idle Detection Time bits in the Time Delay register. The default delay time is 10s. Once the signal activity is detected, the 34827 will quit the Power Save mode and enter the Active mode immediately. In the Power Save mode, the SPK_R/SPK_L to DP/DM switches and the VBUS to MIC switch all keep on. Remote control key pressing in Power Save mode can be responded as in the Active mode.

If the AutoPSAVE bit in FSL Control register is set to '0', the 34827 will not enter Power Save mode automatically.

Under this condition, the baseband can control the mode transition manually by writing the PSAVE bit when the accessory is Audio Type 1 or TTY. If the PSAVE is set to '0', the 34827 keeps in Active mode; if the PSAVE is set to '1', the 34827 keeps in Power Save mode even if the audio signal is applied at SPK_R and SPK_L pins.

If the Manual S/W is set to '0' for Audio Type 1 or TTY, the 34827 has the same mode transition behavior as when the Manual S/W is in default value '1'.

NORMAL OPERATION SETTING OF THE CONTROL BITS

After the VDD and VDDIO are powered up, the 34827 is normally configured to turn on the switches automatically after the attached accessory is identified. Thus the INT_MASK bit must be set to '0', the WAIT bit is normally set to '1', the Manual S/W bit is set to '1', the RAW Data bit is set to '1' and the Switch_Open bit is set to '1'. This is the normal setting of these control bits for the normal operation.

ANALOG AND DIGITAL SWITCHES

The signal switches in the 34827 are shown in [Figure 20](#).

These switches are controlled by the identification result when the Manual S/W = 1 and by the Manual S/W registers when the Manual S/W = 0 in Active mode. The Switch_Open bit overrides the switch configuration. When the Switch_Open bit is 0, all switches, including the power MOSFET, are turned off.

The switches for the SPK_L and SPK_R are capable of passing signals of ± 1.5 V, referencing to GND pin voltage. The SPK_L and SPK_R pins are pulled down to ground via a 100 k Ω resistor respectively, as shown in [Figure 20](#).

When the switches are configured automatically by the identification result, the configuration of the switches vs. the device type is shown in [Table 8](#).

When detachment of an accessory is detected, the 34827 will return to the Standby mode. In the Standby mode, no matter Manual S/W = 1 or Manual S/W = 0, all signal switches and the power MOSFET are off in the Standby mode except for the OUT-to-ground FET SW10. The OUT-to-ground FET is turned on whenever the FET_ON bit is '0'. The ISET and JIG pins output high-impedance and BOOT pin outputs low logic voltage in the Standby mode

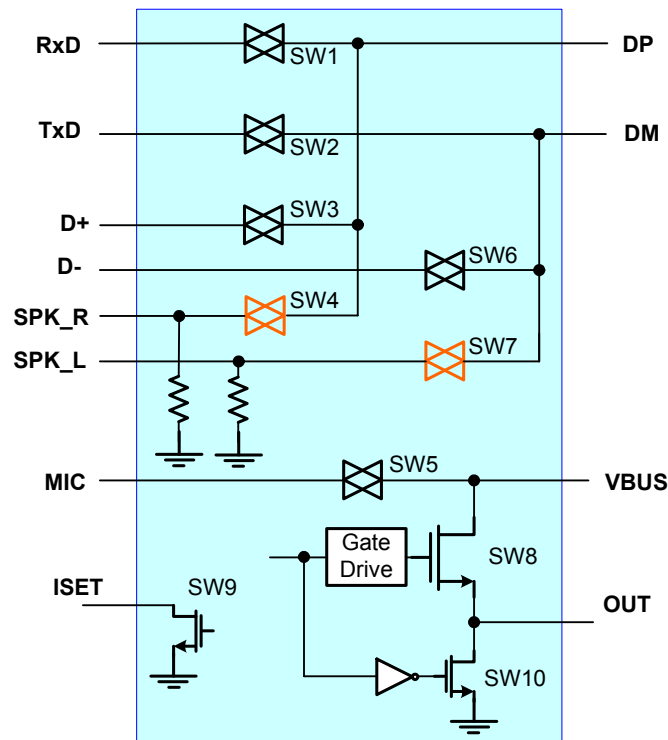
Figure 20. Analog and Digital Switches
Table 8. Switch Configuration when Controlled by the Device Type Register

Device Type	Audio	USB	UART	USB CHG	Dedicated CHG	5WT1 CHG
On SW#	4, 5, 7, 10	3, 6, 8	1, 2, 10	3, 6, 8, 9	8, 9	8
Device Type	5WT2 CHG	JIG_USB_OFF	JIG_USB_ON	JIG_UART_OFF	JIG_UART_ON	TTY
On SW#	8	3, 6, 8	3, 6, 8	1, 2, 10	1, 2, 10	4, 5, 7, 10

POWER MOSFET

An N-channel power MOSFET is implemented in the 34827. For the Audio Type 1 or TTY accessory, the power MOSFET isolates the VBUS pin from both the input decoupling capacitor and the input quiescent current of the charger IC at the OUT pin, so that the microphone signal can be connected to the VBUS pin without any attenuation from the OUT pin. The power MOSFET is also used as the input over-voltage protection (OVP) or over-current protection (OCP) switch for other components such as the charger IC to allow a low-voltage rated charger to be used for cost reduction.

The power MOSFET is guaranteed to be turned on when the VDD voltage is below POR threshold and VBUS is powered up to a voltage range between the POR threshold and the OVP threshold to assure that the cell phone battery can be charged in the VBUS Power mode.

When supported power supply is attached in the Active mode, the power MOSFET keeps on unless it is disabled by

the OCP/OTP block or the FET_DIS signal from the logic block. The FET_DIS signal comes from the following places:

1. when the switches are controlled by the Manual S/W bits
2. when the Switch_Open bit = 0
3. when the accessory is an unknown powered accessory
4. when the FET_ON bit = 0 in the FSL Control register

OVER-VOLTAGE PROTECTION (OVP)

The VBUS line is capable of withstanding a 28 V voltage. The 34827 protects the cell phone by turning off the internal power MOSFET when the VBUS voltage is higher than the OVP threshold. In this case, the gate driver turns off the power MOSFET within 1.0 μ s, and the OVP_EN bit in the Interrupt 1 register is set to interrupt the host. When the OVP event is cleared, the OVP_OTP_DIS bit in the Interrupt 1 register is set to inform the host.

OVER-CURRENT PROTECTION (OCP) AND OVER-TEMPERATURE PROTECTION (OTP)

If the current in the power MOSFET exceeds the specified OCP limit, the 34827 will operate in CC (Constant Current) mode, regulating the output current at the OCP limit. If the OCP condition persists, the IC temperature will rise, eventually reaching the OTP (over-temperature protection) limit. The 34827 then turns off the power MOSFET and sets the OTP_EN interrupt bit in the Interrupt 1 register to inform

the host. The power MOSFET is turned on again when the IC temperature falls below the OTP falling temperature threshold, and the OVP_OTP_DIS bit is set. If this case happens 7 times, the power MOSFET will permanently be turned off until the accessory is attached again, or the IC is reset.

The gate driver turns off the power MOSFET with a limited speed under the OTP case to prevent a high over-shoot voltage at the VBUS pin.

AUDIO DEVICE TYPE 1 -- AUDIO WITH OR WITHOUT THE REMOTE CONTROL

All Audio Type 1 accessories have the same interface shown in [Figure 21](#), either stereo or mono, with or without a remote control, or with or without a microphone. When a device, such as the microphone, is not connected in the accessory, the corresponding pin in the mini-USB connector will be left floating.

With the normal operation setting of the control bits, when the accessory is identified as an Audio Type 1 device, the analog switches SW4, SW7 for SPK_R to DP and SPK_L to DM, and SW5 for VBUS to MIC are turned on, the power MOSFET SW8 is turned off to isolate VBUS pin from OUT pin and the OUT-to-ground FET SW10 is turned on to reduce the leakage current into the VBUS pin.(see the [Figure 20](#) and [Figure 22](#)).

The 34827 supports the remote control key for Audio Type 1 device. If the RAW DATA = 0, the ADC is turned on periodically to monitor the ID line change caused by the key pressing. The period is programmed by the device wake-up bits. If the ADC Result changes, the ADC_Change bit in the Interrupt register 2 is set to inform the baseband. If the RAW DATA = 1, a comparator is enabled to monitor the key pressing.

The timing of the key press when RAW DATA= 1 is shown in [Figure 23](#). If a key is pressed for a time less than 20 ms, the 34827 ignores this key press. If the key is still pressed after 20 ms, the 34827 starts a timer to count the time during which the key is kept being pressed. There are three

conditions according to the press time: Error key press, short key press and long key press.

1. Error key press: if the key press time is less than T_{KP} , Error bit in the Button 2 register and the short key press bit KP in Interrupt 1 register are set to indicate that an error happens. The Error bit is reset to '0' when the Button 2 register is read or next key press happens. The KP bit is cleared when the Interrupt 1 register is read.
2. Short key press: if the key press time is between T_{KP} and T_{LKP} , the KP bit and the corresponding button bit in Button 1 or Button 2 register are set to inform the baseband. If the ADC Result is not one of the ADC values of the 13 buttons, the Unknown bit in the Button 2 register is set. The INTB outputs a low when the key is released and returns to a high when the interrupt register is read. The KP bit is cleared when the Interrupt 1 register is read.
3. Long key press: if the key press time is longer than T_{LKP} , the long key press bit LKP in the Interrupt 2 register and the corresponding button bit are set to inform the baseband. If the ADC Result is not one of the ADC values of the 13 buttons, the Unknown bit in the Button 2 register is set. When the key is released, the long key release bit LKR in the Interrupt 2 register is set to interrupt the baseband again.

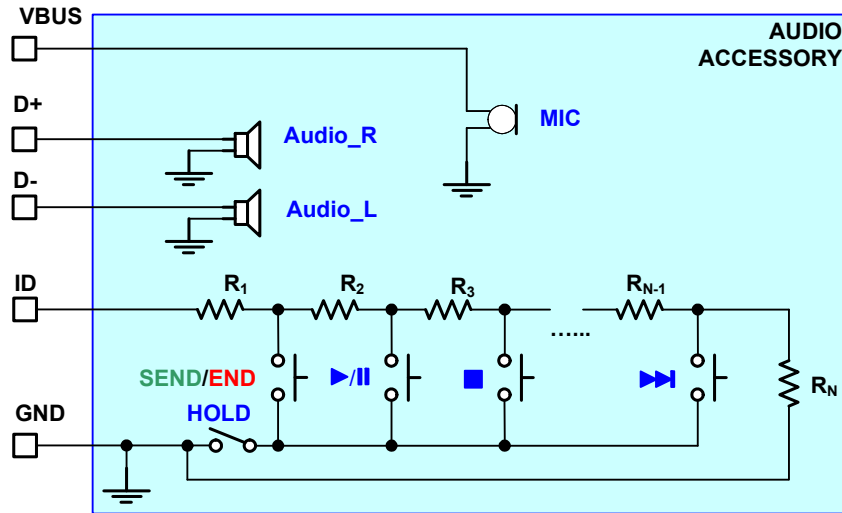

Figure 21. Audio Accessory with Remote Control and Microphone

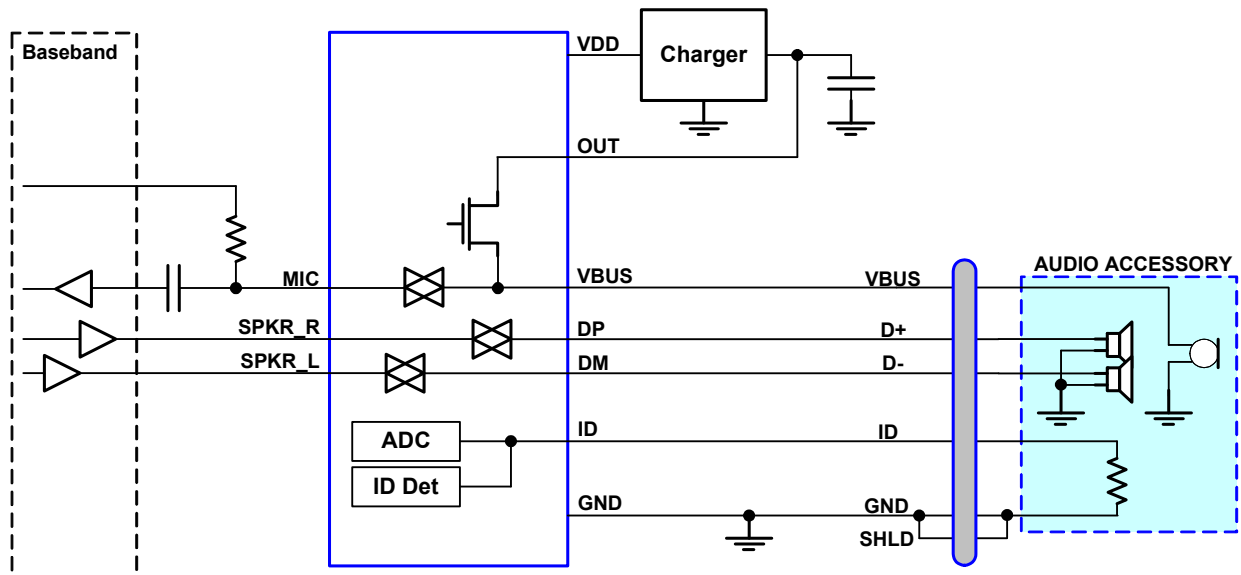

Figure 22. Operation of the Headset with Remote Control and Microphone

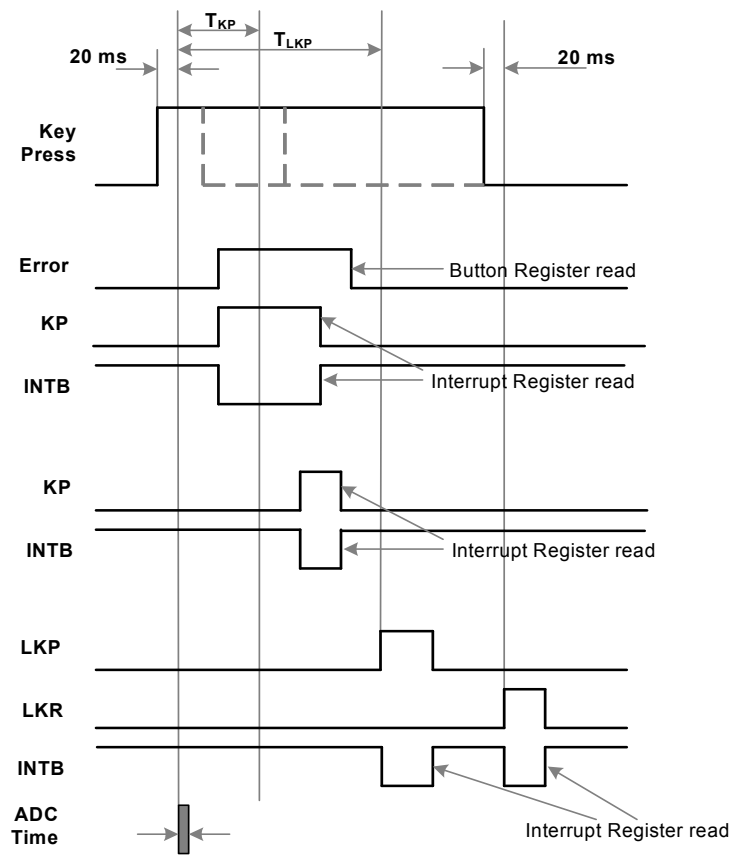

Figure 23. The Remote Control Key Pressing Timing

When AutoPSAVE = 1, if no activity is detected in an Activity Idle Detection Time window, which is programmed by the Activity Idle Detection Time bits in the Time Delay register, the 34827 enters the Power Save mode automatically to minimize the quiescent current. In the Power Save mode, the key pressing is monitored as well. The current to monitor the ID line status is sampled at 5ms period. Upon detecting the activity in signal switches, the 34827 returns to the Active mode.

When AutoPSAVE = 0, the baseband can control the mode of 34827 manually by setting the values of Device Mode register via I²C.

The ID detection circuit continues to be on for detaching detection in the Active mode and samples the ID line every interval programmed by the Device Wake Up bits in the Timing Set 1 register in the Power Save mode. When the ID_FLOAT rising edge is detected, the Detach bit in the Interrupt 1 register is set to inform the host that the accessory is detached. Then the 34827 enters the Standby mode.

JIG CABLE

The JIG cable is for test and development purpose. It has an ID resistance to differentiate it from a regular USB cable, as shown in [Figure 24](#). The Jig cable has four ID resistance values to identify either the Boot-On option is selected and if the cable is a USB or UART type. The detection result sets the JIG and the BOOT outputs, where JIG is an open-drain output and BOOT is a push-pull output

If Manual S/W is set to '1', the relationship between JIG cable Type and the JIG and BOOT outputs is shown in [Table 9](#).

If Manual S/W is set to '0', the switches to be turned on are determined by the value of Manual S/W registers. The BOOT_SW and JIG_ON bits in Manual S/W 2 register can be configured to control the JIG and BOOT outputs manually under this condition. Detailed information can be found in section [Register Map](#).

Table 9. JIG Cable Type and Indications

Device type bit	JIG_USB_ON	JIG_USB_OFF	JIG_UART_ON	JIG_UART_OFF
JIG Output	Low-impedance	Low-impedance	Low-impedance	Low-impedance
BOOT Output	High Logic	Low Logic	High Logic	Low Logic

USB JIG CABLE

With the normal operation setting of the control bits, when the identified accessory is a USB jig cable, both the D+ to DP and the D- to DM switches are switched on (see [Figure 25](#)), the JIG pin outputs a logic low signal, the power MOSFET is on, the ISET output is high-impedance. The BOOT output is dependent on whether or not the BOOT on option. When the JIG_USB_ON bit in the device type register is set, the BOOT pin outputs logic high.

When INT_MASK = 0, the switching action of D+ to DP and the D- to DM switches are controlled by the WAIT bit. If WAIT = 1, the signal switches will be turned on after a WAIT time since the INTB outputs low voltage as for other type accessory. If WAIT = 0, the signal switches won't be turned on until the WAIT bit is set to '1' by I²C. When INT_MASK = 1, no matter the WAIT is set to '0' or '1', the signal switches are turned on once the USB jig cable is identified.

Both the ID detector and the VBUS detector monitor the detachment of the USB jig cable. The ID detection circuit continues to be on for detachment detection in the Active mode. When the ID_FLOAT is set, the Detach bit in the Interrupt 1 register is set to inform the host. When the VBUS_DET is set to '0', which means either the VBUS power is removed or the cable is detached, the Detach bit is also set to inform the host. Then the 34827 moves to the Standby mode. If the Detach bit is set due to the removing of only VBUS or only ID resistance and the cable is not detached

completely, the identification flow will be triggered again since the ID_FLOAT bit or VBUS_DET bit still indicates that an accessory is connected when the 34827 moves to the Standby mode. All the signal switches are turned off.

UART JIG CABLE

With the normal operation setting of the control bits, when the identified accessory is a UART jig cable, both the RxD to DP and the TxD to DM switches are switched on (see [Figure 26](#)), the JIG pin outputs low, the power MOSFET is off. The BOOT output is dependent on whether or not the BOOT on option. When the JIG_UART_ON bit in the device type register is set, the BOOT pin outputs logic high.

When INT_MASK = 0, the switching action of RxD to DP and the TxD to DM switches are controlled by the WAIT bit. If WAIT = 1, the signal switches will be turned on after a WAIT time since the INTB outputs low voltage as for other type accessory. If WAIT = 0, the signal switches won't be turned on until the WAIT bit is set to '1' by I²C. When INT_MASK = 1, no matter the WAIT is set to '0' or '1', the signal switches are turned on once the UART jig cable is identified.

The ID detection comparator continues to be on for detachment detection in the Active mode. When the ID_FLOAT is set, the Detach bit in the Interrupt 1 register is set to inform the host that the accessory is detached. Then the 34827 enters the Standby mode.

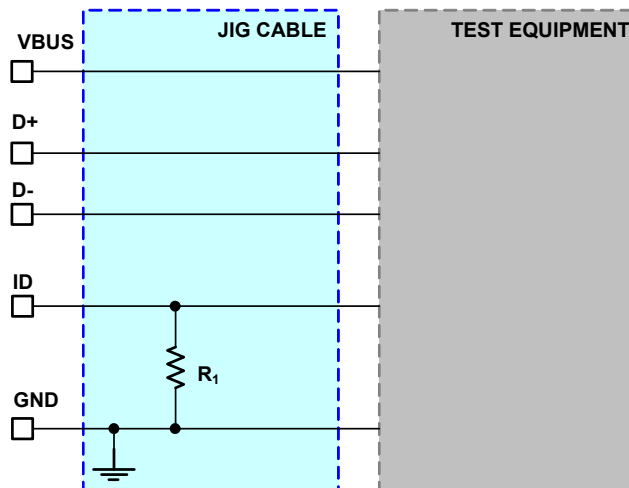

Figure 24. Jig Cable

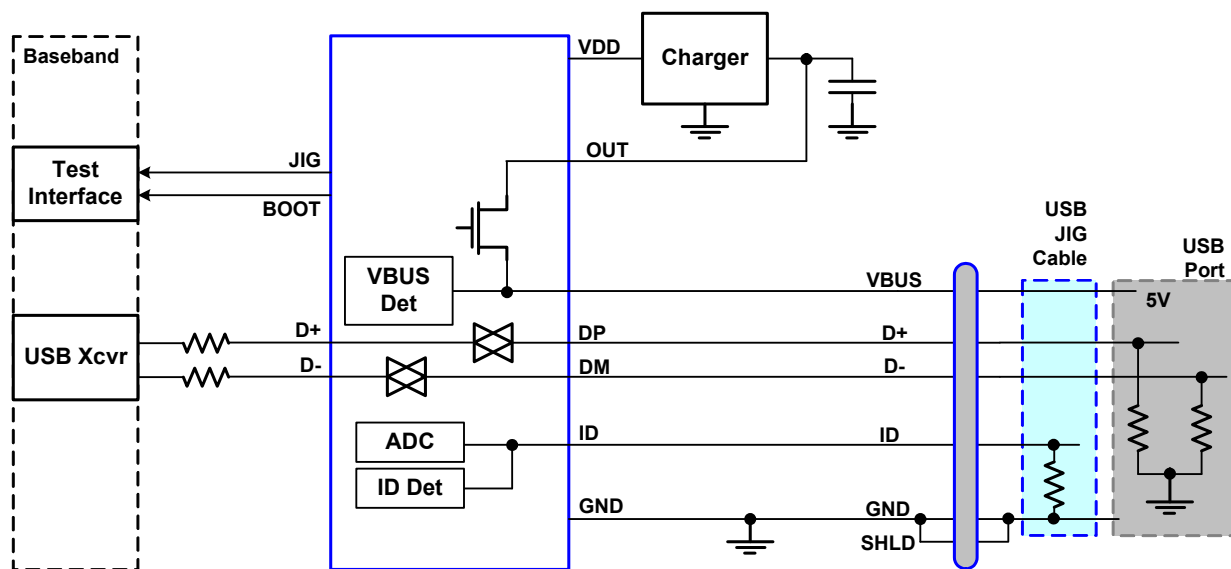

Figure 25. Operation of the USB JIG Cable

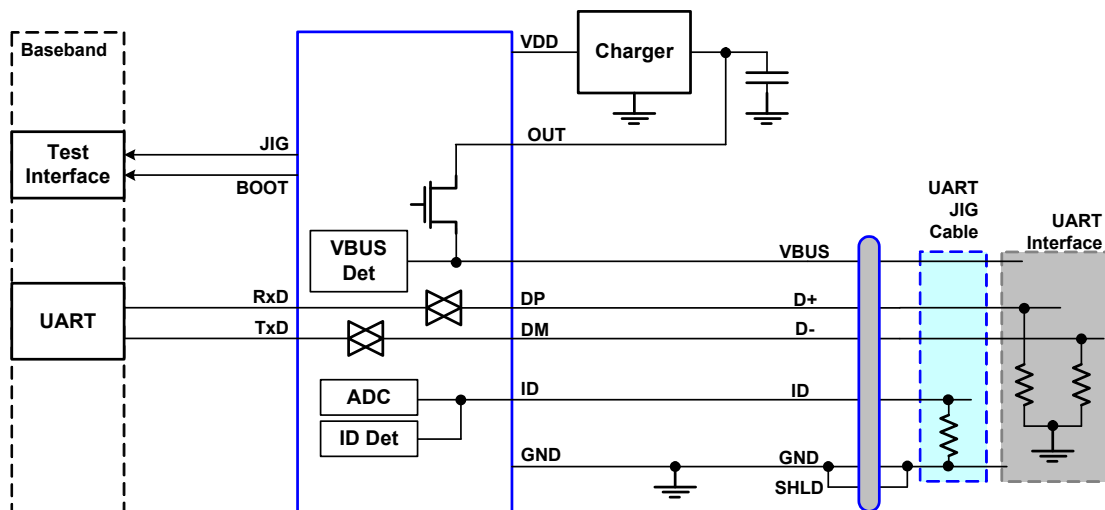

Figure 26. Operation of the UART JIG Cable

TTY CONVERTER

A TTY converter is a type of audio accessory. It has its own ID resistance. When a TTY converter is attached, the TTY bit in the Device Type register and the Attach interrupt bit are set. With the normal operation setting of the control bits, the automatic switch configuration of the TTY converter is similar to that of Audio Type 1 accessory, that is the SPK_R to DP switch and MIC to VBUS switch are turned on, but the SPK_L

to DM switch can only be turned on when TTY_SKPL bit in FSL Control register is set to 1 manually. The TTY accessory doesn't support the remote control key.

The Power Save mode operation and the detachment detection are the same as those of the Audio Type 1 device.

UART

With the normal operation setting of the control bits, when the identified accessory is a UART cable, both the RxD and the TxD switches are switched on (see Figure 27). The power MOSFET is off, and the JIG output high-impedance and the BOOT outputs low-voltage.

The ID detection comparator continues to be on for detachment detection in the Active mode. When the ID_FLOAT is set, the Detach bit in the interrupt register is set to inform the host that the accessory is detached. Then the 34827 enters the Standby mode.

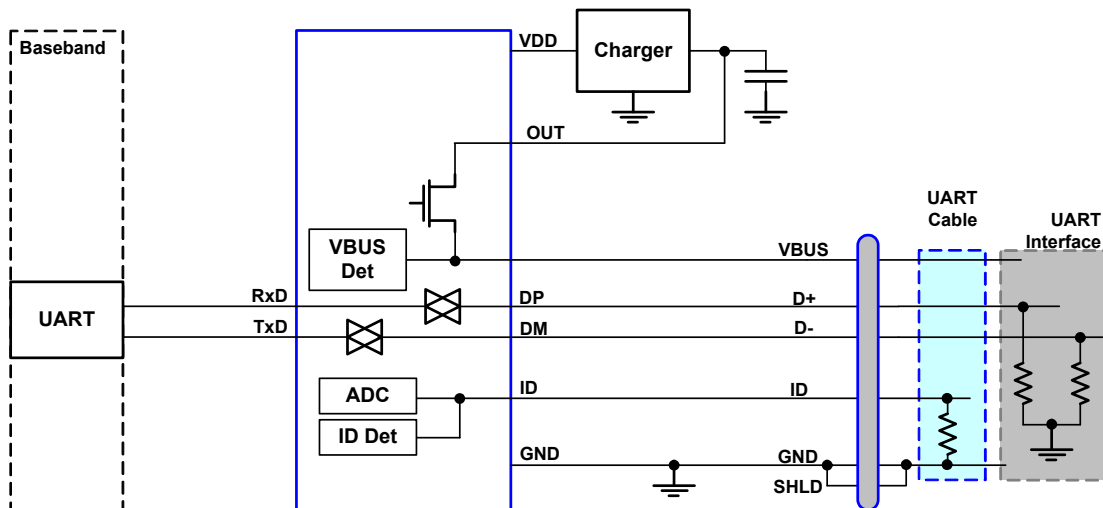

Figure 27. Operation of the UART Cable

USB HOST (PC OR HUB)

When the attached accessory is a USB host or hub, the ID pin is floating. With the normal operation setting of the control bits, both the D+ to DP and the D- to DM switches are switched on (see [Figure 28](#)), the power MOSFET is turned on to allow the charger to charge the battery and the ISET outputs high-impedance to limit the charging current to a lower level.

When INT_MASK = 0, the switching action of D+ to DP and the D- to DM switches are controlled by the WAIT bit. If WAIT = 1, the signal switches will be turned on after a WAIT time since the INTB outputs low voltage as for other type accessory. If WAIT = 0, the signal switches won't be turned

on until the WAIT bit is set to '1' by I²C. When INT_MASK = 1, no matter the WAIT is set to '0' or '1', the signal switches are turned on once the USB host is identified.

After the D+ to DP and the D- to DM switches are turned on, the baseband can pull the D+ signal to high to start the USB attaching sequence.

The detachment is detected by the falling edge of the VBUS_DET signal. When the VBUS_DET falls, the Detach bit is set to inform the baseband. Then the 34827 enters the Standby mode.

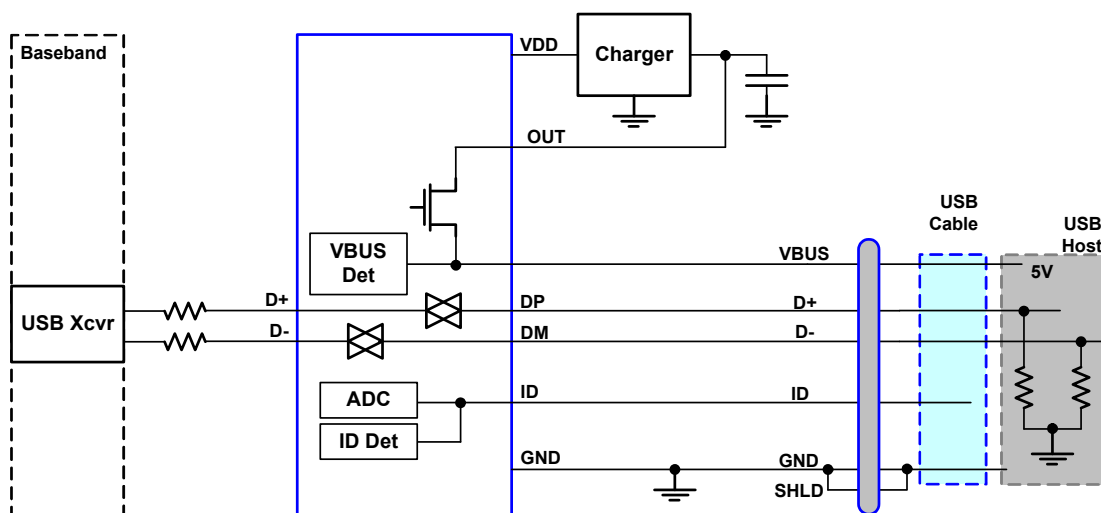

Figure 28. Operation of the USB Cable

USB CHARGER OR DEDICATED CHARGER

When the attached accessory is a USB charger or dedicated charger, the 34827 turns on the power MOSFET to allow the charger to start and the ISET outputs low-impedance to allow a higher charge current. With the normal operation setting of the control bits, the D+ and D- switches are turned on for the USB charger but not for the dedicated charger.

The VBUS detector is used to monitor the detachment of the charger. The falling edge of VBUS_DET is an indication of the charger detachment. Both unplugging the mini-USB connector and unplugging the ac side lead to the same detachment conclusion. The detach bit is set to inform the host. Then the 34827 enters the Standby mode.

5-WIRE CHARGER (TYPE 1 OR TYPE 2) OR A/V CHARGER

When the attached accessory is a 5-Wire Charger or A/V Charger, the 34827 turns on the power MOSFET to allow the charger to start and the ISET outputs high-impedance.

The VBUS detector is used to monitor the detachment of the charger. The falling edge of VBUS_DET is an indication

of the charger detachment. Both unplugging the mini-USB connector and unplugging the ac side lead to the same detachment conclusion. The detach bit is set to inform the host. Then the 34827 enters the Standby mode.

UNKNOWN ACCESSORY

When an unknown accessory is attached, either the ID_FLOAT bit is cleared or the VBUS_DET bit is set to '1'. Only the Unknown_Atta bit is set to interrupt the baseband.

The attach bit is not set to distinguish the unknown accessory from the known accessory. No other actions are taken.

If an unknown powered accessory is attached, the power MOSFET is turned on during the identification process and

the power MOSFET will be turned off immediately when the accessory is identified as unknown accessory.

Either the falling edge of the VBUS_DET or the rising edge of the ID_FLOAT signals can trigger the detachment

detection. Detach bit is set to inform the detachment of the unknown accessory. Then the 34827 enters the Standby mode.

RESET FEATURES

HARDWARE RESET

There are three sources of hardware resetting for the 34827 as the [Figure 29](#) shows, including the Power-on Reset caused by the powered up VDD, a hardware reset by VDDIO input and a hardware reset by the I²C bus lines.

The VDD Power-on Reset is described earlier. The hardware reset by I²C signals is shown in [Figure 30](#). When both the I2C_SCL and the I2C_SDA have a negative pulse for longer than T_{RSTI2C} , a hardware reset is generated.

The operating waveforms of hardware reset by VDDIO are shown in [Figure 31](#). A glitch on the VDDIO with duration less than a deglitch time $T_{VDDIODGT}$ will be ignored. If the negative pulse on the VDDIO lasts longer than the deglitch time, a

reset by VDDIO is generated. The reset signal has a width of 160 μ s typically.

All registers except 0x01H will be reset to the default values when hardware reset happens. During the reset process, the 34827 will not respond to any attachment or detachment activities.

SOFTWARE RESET

The 34827 supports a software reset, which is realized by writing the Reset bit in 0x21H register to 1. The Reset bit will be cleared to 0 at once since it is of W/C type. The consequence of the software reset is the same as the hardware reset. All registers except 0x01H will be reset.

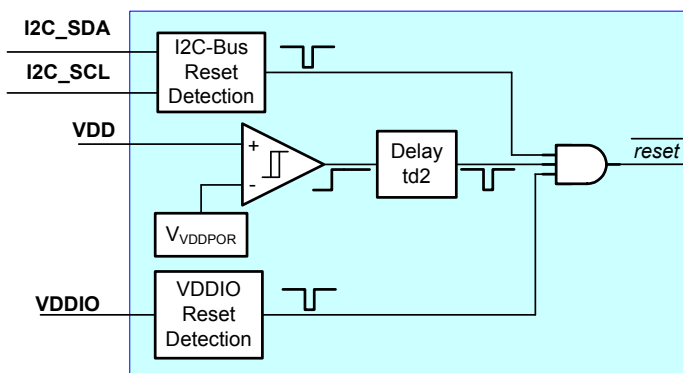

Figure 29. Sources of Reset in the 34827

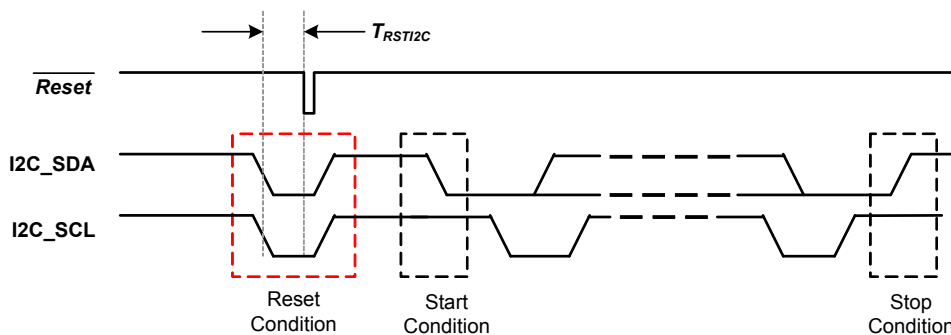

Figure 30. Hardware Reset Using the I²C Bus

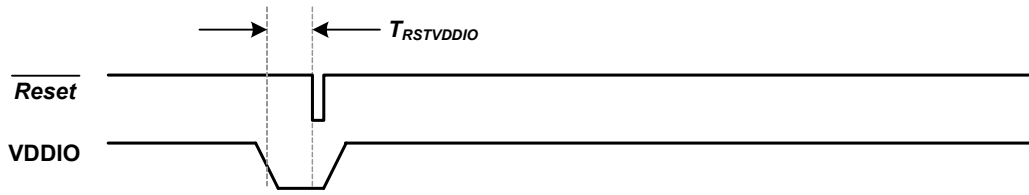

Figure 31. Hardware Reset Using the VDDIO Input

I²C SERIAL BUS INTERFACE

The I²C bus is enabled in the Standby, the Power Save, and the Active modes. The serial clock (SCL) and the serial data (SDA) lines must be connected to a positive supply using pull-up resistors. The 34827 is a slave device. Maximum data rate is 400 kbps.

ADDRESSING AND PROTOCOL

The 7-bit address for the 34827 is default to 0100101, as shown in Figure 32.



Figure 32. I²C Slave Address

The following three figures show three I²C-bus transaction protocols. The Word Address is an 8-bit register address in the 34827.

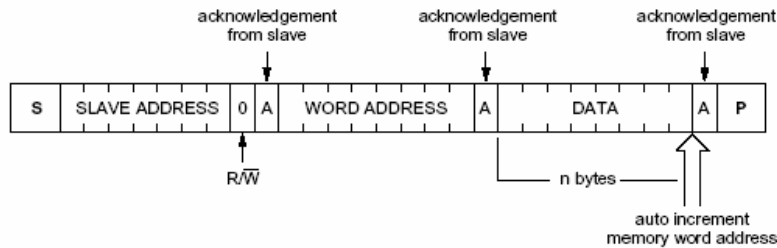

Figure 33. Master Transmits to Slave (Write Mode)

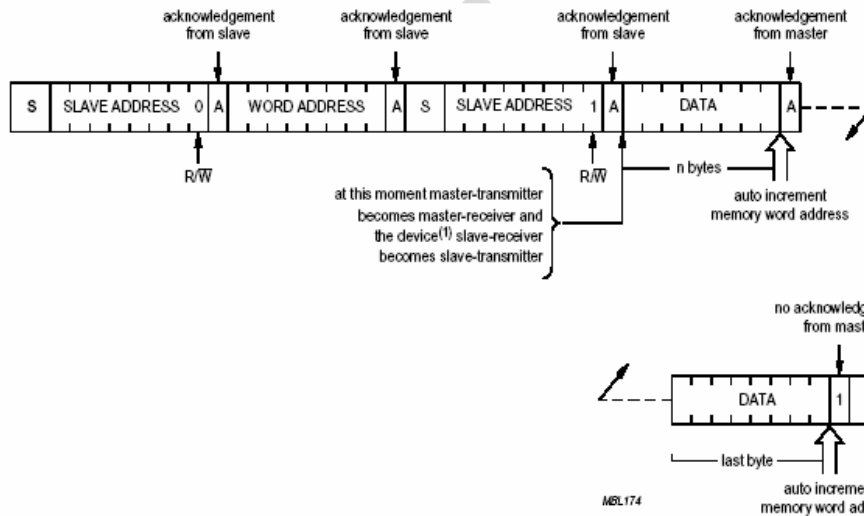

Figure 34. Master Reads After Setting Word Address (Write Word Address and then Read Data)

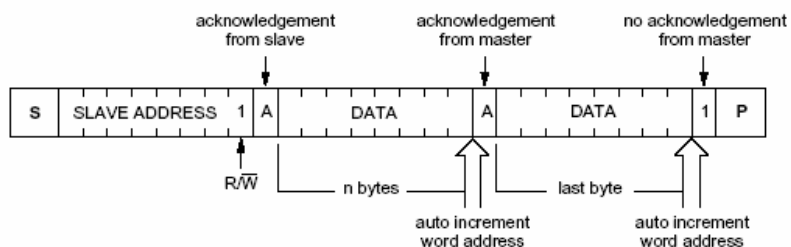

Figure 35. Master Reads Slave Immediately After First Byte (Read Mode)

I²C MODULE INTERFACES

Figure 36 shows the conceptual block diagram. The Word Address is an 8-bit register that stores the register address

the I²C bus reads from or write to. The Word Address automatically increment after each byte of bus access.

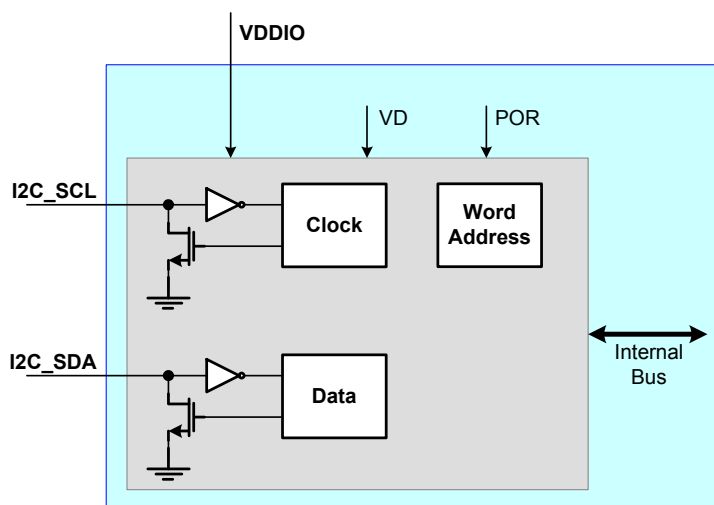

Figure 36. I²C Module Conceptual Block Diagram

REGISTER MAP

Table 10. Register Map

Addr	Register	Type	Rest Value	Bit 7	Bit 6	Bit 5	Bit 4	Bit 3	Bit 2	Bit 1	Bit 0	
01H	Device ID	R	00010001	Version ID					Vendor ID			
02H	Control	R/W	00011111	Reserved	Reserved	Reserved	Switch_Open	RAW DATA	Manual S/W	Wait	INT_MASK	
03H	Interrupt 1	R/C	00H	OVP_OTP_DIS	OTP_EN	OVP_EN	LKR	LKP	KP	Detach	Attach	
04H	Interrupt 2	R/C	00H	Reserved	Reserved	Reserved	Stuck_Key_RCV	Stuck_Key	ADC_Change	Unknown_Atta	A/V_Charging	
05H	Interrupt Mask 1	R/W	00H	OVP_OTP_DIS_m	OTP_EN_m	OVP_EN_m	LKR_m	LKP_m	KP_m	Detach_m	Attach_m	
06H	Interrupt Mask 2	R/W	00H	Reserved	Reserved	Reserved	Stuck_Key_RCV_m	Stuck_Key_m	ADC_Change_m	Unknown_Atta_m	A/V_Charging_m	
07H	ADC Result	R	00011111	Reserved	Reserved	Reserved	ADC Result					
08H	Timing Set 1	R/W	00H	Key Press				Device Wake Up				
09H	Timing Set 2	R/W	00H	Switching Wait				Long Key Press				
0AH	Device Type 1	R	00H	USB OTG	Dedicated CHG	USB CHG	5W CHG	UART	USB	Audio Type 2	Audio Type 1	
0BH	Device Type 2	R	00H	Reserved	A/V	TTY	PPD	JIG_UART_OFF	JIG_UART_ON	JIG_USB_OFF	JIG_USB_ON	
0CH	Button 1	R/C	00H	7	6	5	4	3	2	1	0	
0DH	Button 2	R/C	00H	Reserved	Unknown	Error	12	11	10	9	8	
0E-12H	Reserved											
13H	Manual S/W 1	R/W	00H	DM Switching			DP Switching			VBUS Switching		
14H	Manual S/W 2	R/W	00H	Reserved	Reserved	Reserved	CHG_DET	BOOT_SW	JIG_ON	Reserved		
20H	FSL Status	R	0x110xxx	Reserved	FET_STATUS	ID_DET_END	VBUS_DET_END	ID_GND	ID_FLOAT	VBUS_DET	ADC_STATUS	
21H	FSL Control	R/W	001000x0	FSL_TEST	TTY_SPKL	AutoPSAVE	Reserved	Reserved	RESET	FET_ON	Reserved	
22H	Time Delay	R/W	10010100	Activity Idle Detection Time				TD				
23H	Device Mode	R/W	01H	Reserved	Reserved	Reserved	Reserved	Reserved	PSAVE	ACTIVE	RST	

Table 11. Device ID Register

Bit	Mode	Symbol	Reset	Description	Notes
2-0	R	Vendor ID	001	A unique number for chip vendor	
7-3	R	Version ID	00010	A unique number for chip version	(17)

Notes:

- 17. the initial version is 00010. For the actual version please consult the factory.

Table 12. Control Register

Bit	Mode	Symbol	Reset	Description	Notes
0	R/W	INT_MASK	1	Master mask for the interrupt 0: Enable the interrupt output at the INTB pin. The timing of switching action is determined by Wait bit. 1: Disable the interrupt output at the INTB pin. Under this condition, INTB outputs low voltage, and the signal switches for attached accessories except JIG cable will not be turned on. The baseband shouldn't read interrupt registers before this bit is changed to 0.	
1	R/W	Wait	1	Wait or not to wait for the command from the baseband before turning on the analog or digital switches for attached accessory 0: Wait until this bit is changed to 1. Turn on the switches immediately when this bit is changed to 1. 1: Wait for only the time programmed by the Switching Wait bits in Timing Set 2 register before turning on the switches.	
2	R/W	Manual S/W	1	Manual or automatic switching of the switches 0: manual: the switches are controlled by the Manual S/W registers. 1: auto: the switches are controlled by the Device Type registers	
3	R/W	RAW DATA	1	Interrupt behavior selection 0: Enable the ADC conversion periodically and report the ADC Result changes on ID pin to the host. 1: Enable the key press monitor circuit to detect the ID pin status changes and report the key press events to the host.	
4	R/W	Switch_Open	1	Switch connection selection 0: Open all switches 1: Switch selection according to the Manual S/W bit.	
7-5	R/W	Reserved	000		

Table 13. Interrupt Register 1

Bit	Mode	Symbol	Reset	Description	Notes
0	R/C	Attach	0	1: accessory attached	
1	R/C	Detach	0	1: accessory detached	
2	R/C	KP	0	1: remote controller key is pressed	
3	R/C	LKP	0	1: remote controller long key is pressed	
4	R/C	LKR	0	1: remote controller long key is released	
5	R/C	OVP_EN	0	1: VBUS voltage higher than the OVP threshold	
6	R/C	OTP_EN	0	1: The temperature of the 34827 is above the OTP threshold	
7	R/C	OVP_OTP_DIS	0	1: OVP or OTP event is removed	

Table 14. Interrupt Register 2

Bit	Mode	Symbol	Reset	Description	Notes
0	R/C	A/V_Charging	0	1: a charger is detected when the A/V cable is attached	
1	R/C	Unknown_Atta	0	1: an unknown accessory is attached	
2	R/C	ADC_Change	0	1: ADC Result has changed when the RAW DATA = 0	
3	R/C	Stuck_Key	0	1: Stuck key is detected	

Table 14. Interrupt Register 2

Bit	Mode	Symbol	Reset	Description	Notes
4	R/C	Stuck_Key_RCV	0	1: Stuck key is recovered	
7-5		Reserved	000		

Table 15. Interrupt Mask Register1

Bit	Mode	Symbol	Reset	Description	Notes
0	R/W	Attach_m	0	1: interrupt output disabled	
1	R/W	Detach_m	0	1: interrupt output disabled	
2	R/W	KP_m	0	1: interrupt output disabled	
3	R/W	LKP_m	0	1: interrupt output disabled	
4	R/W	LKR_m	0	1: interrupt output disabled	
5	R/W	OVP_EN_m	0	1: interrupt output disabled	
6	R/W	OTP_EN_m	0	1: interrupt output disabled	
7	R/W	OVP_OTP_DIS_m	0	1: interrupt output disabled	

Table 16. Interrupt Mask Register 2

Bit	Mode	Symbol	Reset	Description	Notes
0	R/W	A/V_CHG_m	0	1: interrupt output disabled	
1	R/W	Unknown_Atta_m	0	1: interrupt output disabled	
2	R/W	ADC_Change_m	0	1: interrupt output disabled	
3	R/W	Stuck_Key_m	0	1: interrupt output disabled	
4	R/W	Stuck_Key_RCV_m	0	1: interrupt output disabled	
7-5		Reserved	000		

Table 17. ADC Result Register

Bit	Mode	Symbol	Reset	Description	Notes
4-0	R	ADC Result	00000	ADC result value of the resistance at ID pin	
7-5	R	Reserved	000		

Table 18. Timing Set Register 1

Bit	Mode	Symbol	Reset	Description	Notes
3-0	R/W	Device Wake-up	0000	The periodical sampling time of the ID line in the Power-save mode and Standby mode; the periodical time of ADC conversion of the resistance at ID pin when RAW DATA = 0. 0000: 50 ms 0001: 100 ms 0010: 150 ms 0011: 200 ms 0100: 300 ms ...	

Table 18. Timing Set Register 1

Bit	Mode	Symbol	Reset	Description	Notes
7-4	R/W	Key Press	0000	Normal key press duration 0000: 100 ms 0001: 200 ms 0010: 300 ms ...	

Table 19. Timing Set Register 2

Bit	Mode	Symbol	Reset	Description	Notes
3-0	R/W	Long Key Press	0000	Long key press duration 0000: 300 ms 0001: 400 ms 0010: 500 ms ...	
7-4	R/W	Switching Wait	0000	Waiting time before switching the analog or digital switches: 0000: 10 ms 0001: 30 ms 0010: 50 ms ...	

Table 20. Timing Table

Setting Value	Device Wake-up	Key Press	Long Key Press	Switching Wait
0000	50 ms	100 ms	300 ms	10 ms
0001	100 ms	200 ms	400 ms	30 ms
0010	150 ms	300 ms	500 ms	50 ms
0011	200 ms	400 ms	600 ms	70 ms
0100	300 ms	500 ms	700 ms	90 ms
0101	400 ms	600 ms	800 ms	110 ms
0110	500 ms	700 ms	900 ms	130 ms
0111	600 ms	800 ms	1000 ms	150 ms
1000	700 ms	900 ms	1100 ms	170 ms
1001	800 ms	1000 ms	1200 ms	190 ms
1010	900 ms	-	1300 ms	210 ms
1011	1000 ms	-	1400 ms	-
1100	-	-	1500 ms	-
1101	-	-	-	-
1110	-	-	-	-
1111	-	-	-	-

Table 21. Device Type Register 1

Bit	Mode	Symbol	Reset	Description	Notes
0	R	Audio Type 1	0	1: an audio type 1 accessory is attached	
1	R	Audio Type 2	0	1: an audio type 2 accessory is attached	

Table 21. Device Type Register 1

Bit	Mode	Symbol	Reset	Description	Notes
2	R	USB	0	1: a USB host is attached	
3	R	UART	0	1: a UART cable is attached	
4	R	5W CHG	0	1: a 5-wire charger (type 1 or 2) is attached	
5	R	USB CHG	0	1: a USB charger is attached	
6	R	Dedicated	0	1: a dedicated charger is attached	
7	R	USB OTG	0	1: a USB OTG accessory is attached	

Table 22. Device Type Register 2

Bit	Mode	Symbol	Reset	Description	Notes
0	R	JIG_USB_ON	0	1: A USB jig cable with the BOOT-off option is attached	
1	R	JIG_USB_OFF	0	1: a USB jig cable with the BOOT-on option is attached	
2	R	JIG_UART_ON	0	1: a UART jig cable with the BOOT-off option is attached	
3	R	JIG_UART_OFF	0	1: a UART jig cable with the BOOT-on option is attached	
4	R	PPD	0	1: a phone powered device is attached	
5	R	TTY	0	1: a TTY converter is attached	
6	R	A/V	0	1: an audio/video cable is attached	
7	R	Reserved	0		

Table 23. Remote Controller Button Register 1

Bit	Mode	Symbol	Reset	Description	Notes
0	R/C	Send_End	0	1: the Send_End button is pressed	
1	R/C	1	0	1: button 1 is pressed	
2	R/C	2	0	1: button 2 is pressed	
3	R/C	3	0	1: button 3 is pressed	
4	R/C	4	0	1: button 4 is pressed	
5	R/C	5	0	1: button 5 is pressed	
6	R/C	6	0	1: button 6 is pressed	
7	R/C	7	0	1: button 7 is pressed	

Table 24. Remote Controller Button Register 2

Bit	Mode	Symbol	Reset	Description	Notes
0	R/C	8	0	1: button 8 is pressed	
1	R/C	9	0	1: button 9 is pressed	
2	R/C	10	0	1: button 10 is pressed	
3	R/C	11	0	1: button 11 is pressed	
4	R/C	12	0	1: button 12 is pressed	
5	R/C	Error	0	1: button error occurred	
6	R/C	Unknown	0	1: an unknown button is pressed	
7	R/C	Reserved	0		

Table 25. Manual Switching Register 1

Bit	Mode	Symbol	Reset	Description	Notes
1-0	R/W	VBUS Switching	00	VBUS line switching configuration when Manual S/W = 0 00: open all switches 01: internal power MOSFET on 10: VBUS connects to MIC Others: open all switches connected to the VBUS line.	
4-2	R/W	DP Switching	000	DP line switching configuration when Manual S/W = 0 000: open all switches 001: DP connected to D+, DM connected to D- 010: DP connected to SPK_R, DM connected to SPK_L 011: DP connected to RxD, DM connected to TxD Others: open all switches connected to the DP pin and DM pin	
7-5	R	DM Switching	000	DM line switching configuration when Manual S/W = 0 000: open all switches 001: DP connected to D+, DM connected to D- 010: DP connected to SPK_R, DM connected to SPK_L 011: DP connected to RxD, DM connected to TxD Others: open all switches connected to the DP pin and DM pin	(18)

Notes:

18. DM Switching bits are read-only and equal to the corresponding bits in DP switching bits.

Table 26. Manual Switching Register 2

Bit	Mode	Symbol	Reset	Description	Notes
1-0	R/W	Reserved	00		
2	R/W	JIG_ON	0	JIG output when Manual S/W = 0 0: low impedance 1: high impedance	
3	R/W	BOOT_SW	0	BOOT output when Manual S/W = 0 0: low logic voltage 1: high logic voltage	
4	R/W	CHG_DET	0	ISET output when Manual S/W = 0 0: high impedance 1: low impedance	
7-5	R/W	Reserved	000		

Table 27. FSL Status Register 1

Bit	Mode	Symbol	Reset	Description	Notes
0	R	ADC_STATUS	x	ADC conversion status 1: ADC conversion completed 0: ADC conversion in progress	
1	R	VBUS_DET	x	VBUS voltage is higher than the POR 0: no 1: yes	

Table 27. FSL Status Register 1

Bit	Mode	Symbol	Reset	Description	Notes
2	R	ID_FLOAT	x	ID line is floating 0: no 1: yes	
3	R	ID_GND	0	ID pin is shorted to ground 0: no 1: yes	
4	R	VBUS_DET_END	1	VBUS power supply type identification completed 0: no 1: yes	
5	R	ID_DET_END	1	ID resistance detection finished 0: no 1: yes	
6	R	FET_STATUS	x	The on/off status of the power MOSFET 0: off 1: on	
7	R	Reserved	0		

Table 28. FSL Control Register

Bit	Mode	Symbol	Reset	Description	Notes
0	R/W	Reserved	0		
1	R/W	FET_ON	x	The ON/OFF control of the power MOSFET 0: off 1: on	(19)
2	W/C	RESET	0	Soft reset. When written to 1, the IC is reset. Once the reset is complete, the RST bit is set and the RESET bit is cleared automatically. 1: to soft-reset the IC	
3	R/W	Reserved	0		
4	R/W	Reserved	0		
5	R/W	AutoPSAVE	1	Automatic Power-save mode detection control 0: disable automatic Power Save mode detection. Device can enter Power Save mode via the I ² C. 1: enable automatic Power Save mode detection. Device cannot enter Power Save mode via the I ² C.	
6	R/W	TTY_SPKL	0	SPK_L to DM switch control 0: Turn off the SPK_L to DM switch 1: Turn on the SPK_L to DM switch for TTY	
7	R/W	FSL_TEST	0	Access control for Freescale test registers 0x24H, 0x25H and 0x26H 0: I ² C cannot access FSL test registers 0x24H, 0x25H and 0x26H 1: I ² C can access FSL test registers 0x24H, 0x25H and 0x26H	

Notes:

19. The reset value will be 1 if the VBUS is powered.

Table 29. Time Delay Register

Bit	Mode	Symbol	Reset	Description	Notes
3-0	R/W	TD	0100	Time delay to start the powered accessory identification flow after detecting the bus voltage 0000: 100 ms 0001: 200 ms 0010: 300 ms 0011: 400 ms 0100: 500 ms ... 1111:1600 ms	
7-4	R/W	Activity Idle Detection Time	1001	The time for no activity in the switches before entering the Power Save mode automatically for Audio Type 1 or TTY device 0000: 1 s 0001: 2 s ... 1001:10 s ... 1111:16 s	

Table 30. Device Mode Register

Bit	Mode	Symbol	Reset	Description	Notes
0	R/C	RST	1	This bit indicates if a chip reset has occurred. This bit will be cleared once being read. 0: no. 1: Yes.	
1	R/W	ACTIVE	0	Indicate either the device is in Active mode 0: Standby 1: Active	
2	R/W	PSAVE	0	To indicate either the device is in Power-save mode 0: no 1: yes	
7-3		Reserved	00000		

TYPICAL APPLICATIONS

APPLICATION INFORMATION

ID RESISTANCE VALUE ASSIGNMENT

The ID resistors used with the 34827 are standard 1% resistors. [Table 33](#) shows a table of standard E96 resistor values.

The ADC Result values vs. all 32 ID-resistance values are listed in [Table 7](#). [Table 32](#) shows the remote control buttons vs. the ADC Result values and the ID-resistance values. These functions are tentative and will be decided by Samsung. The remote control architecture is illustrated in [Figure 37](#). The recommended resistors for the remote control resistor network are given in [Table 31](#).

[Table 34](#) lists the complete 32 ID-resistor assignment. The ones with the Assigned Functions filled are the ones that are already used. The ones reserved can be assigned to other functions.

Table 31. Remote Control Resistor Values (Unit: k Ω)

Resistor	Standard Value	ID Resistance
R1	2.0	2.0
R2	0.604	2.604
R3	0.604	3.208
R4	0.806	4.014
R5	0.806	4.82
R6	1.21	6.03
R7	2.0	8.03
R8	2.0	10.03
R9	2.0	12.03
R10	2.43	14.46
R11	2.8	17.26
R12	3.24	20.5
R13	3.57	24.07
R14	976	1000

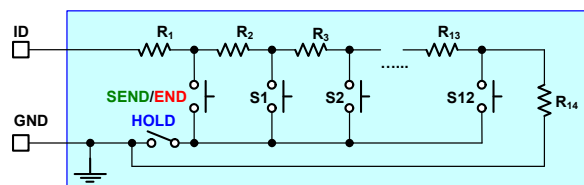

Figure 37. Remote Control Architecture

Table 32. ADC Output and ID Resistor Values for Remote Control Buttons (Unit: k Ω)

Item#	Functions	ID ADC Result	R _{ID} Value
1	Send/End	00001	2.0
2	S1	00010	2.604
3	S2	00011	3.208
4	S3	00100	4.014
5	S4	00101	4.82
6	S5	00110	6.03
7	S6	00111	8.03
8	S7	01000	10.03
9	S8	01001	12.03
10	S9	01010	14.46
11	S10	01011	17.26
12	S11	01100	20.5
13	S12	01101	24.07

Table 33. E96 Series Resistor Values (Unit: k Ω)

1	1.02	1.05	1.07	1.1	1.13
1.15	1.18	1.21	1.24	1.27	1.3
1.33	1.37	1.4	1.43	1.47	1.5
1.54	1.58	1.62	1.65	1.69	1.74
1.78	1.82	1.87	1.91	1.96	2
2.05	2.1	2.15	2.21	2.26	2.32
2.37	2.43	2.49	2.55	2.61	2.67
2.74	2.8	2.87	2.94	3.01	3.09
3.16	3.24	3.32	3.4	3.48	3.57
3.65	3.74	3.83	3.92	4.02	4.12
4.22	4.32	4.42	4.53	4.64	4.75
4.87	4.99	5.11	5.23	5.36	5.49
5.62	5.76	5.9	6.04	6.19	6.34
6.49	6.65	6.81	6.98	7.15	7.32
7.5	7.68	7.87	8.06	8.25	8.45
8.66	8.87	9.09	9.31	9.53	9.76
10	10.2	10.5	10.7	11.0	11.3
11.5	11.8	12.1	12.4	12.7	13
13.3	13.7	14	14.3	14.7	15

Table 33. E96 Series Resistor Values (Unit: k Ω)

15.4	15.8	16.2	16.5	16.9	17.4
17.8	18.2	18.7	19.1	19.6	20
20.5	21	21.5	22.1	22.6	23.2
23.7	24.3	24.9	25.5	26.1	26.7
27.4	28	28.7	29.4	30.1	30.9
31.6	32.4	33.2	34	34.8	35.7
36.5	37.4	38.3	39.2	40.2	41.2
42.2	43.2	44.2	45.3	46.4	47.5
48.7	49.9	51.1	52.3	53.6	54.9
56.2	57.6	59	60.4	61.9	63.4
64.9	66.5	68.1	69.8	71.5	73.2
75	76.8	78.7	80.6	82.5	84.5
86.8	88.7	90.9	93.1	95.3	97.6
100	102	105	107	110	113
115	118	121	124	127	130
133	137	140	143	147	150
154	158	162	165	169	174
178	182	187	191	196	200
205	210	215	221	226	232
237	243	249	255	261	267
274	280	287	294	301	309
316	324	332	340	348	357
365	374	383	392	402	412
422	432	442	453	464	475
487	499	511	523	536	549
562	576	590	604	619	634
649	665	681	698	715	732
750	7.8	787	806	825	845
868	887	909	931	953	976

Table 34. ID Resistance Assignment (Unit: k Ω)

Item#	ADC Result	ID Resistance	Assignment
0	00000	-	A/V or USBOTG
1	00001	2.0	SEND_END

Table 34. ID Resistance Assignment (Unit: k Ω)

Item#	ADC Result	ID Resistance	Assignment
2	00010	2.604	S1
3	00011	3.208	S2
4	00100	4.014	S3
5	00101	4.820	S4
6	00110	6.03	S5
7	00111	8.03	S6
8	01000	10.03	S7
9	01001	12.03	S8
10	01010	14.46	S9
11	01011	17.26	S10
12	01100	20.5	S11
13	01101	24.07	S12
14	01110	28.7	Reserved
15	01111	34.0	Reserved
16	10000	40.2	Reserved
17	10001	49.9	Reserved
18	10010	64.9	Reserved
19	10011	80.07	Audio Type 2
20	10100	102	PPD
21	10101	121	TTY
22	10110	150	UART
23	10111	200	5W_T1
24	11000	255	JIG_USB_OFF
25	11001	301	JIG_USB_ON
26	11010	365	A/V
27	11011	442	5W_T2
28	11100	523	JIG_UART_OFF
29	11101	619	JIG_UART_ON
30	11110	1000	Audio/Remote Controller
30	11110	1002	Audio/Only Send_End
31	11111	-	ID FLOAT

DECOUPLING CAPACITOR

Decoupling capacitors are required at all power supply input and output pins. For VDD pin, a X5R capacitor of 1.0 μF is recommended. For VBUS pin, because it also acts as the microphone input, the decoupling capacitance at VBUS pin must be carefully considered. Assuming the voice band is 3.4 kHz and the pull-up resistance for the microphone is 2.0 k Ω , the decoupling capacitance at the VBUS pin should be less than 22 nF. A 4.7 nF X5R capacitor is recommended for the typical application.

ACCESSORY IDENTIFICATION TIMING

When an accessory is connected to the 34827, the 34827 identifies the accessory type and then interrupts the cell phone baseband. [Figure 38](#) to [Figure 41](#) show the identification timing for different accessories. When the phone is on the power-on state, the VDDIO has already been powered. When the phone is on the power-off state, the VDDIO is not powered yet. Once the VDDIO is powered, the I²C of the 34827 can be accessed.

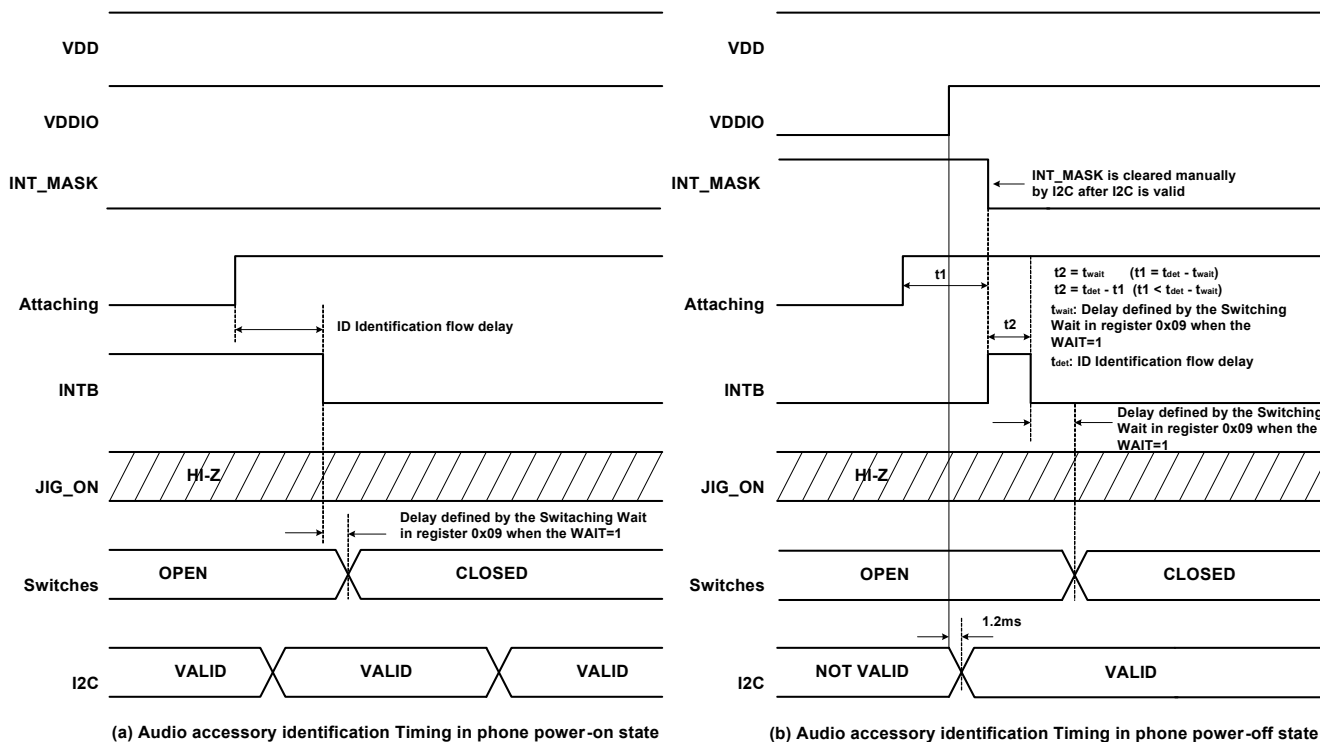

Figure 38. ID Based Accessory Identification Timing Diagram

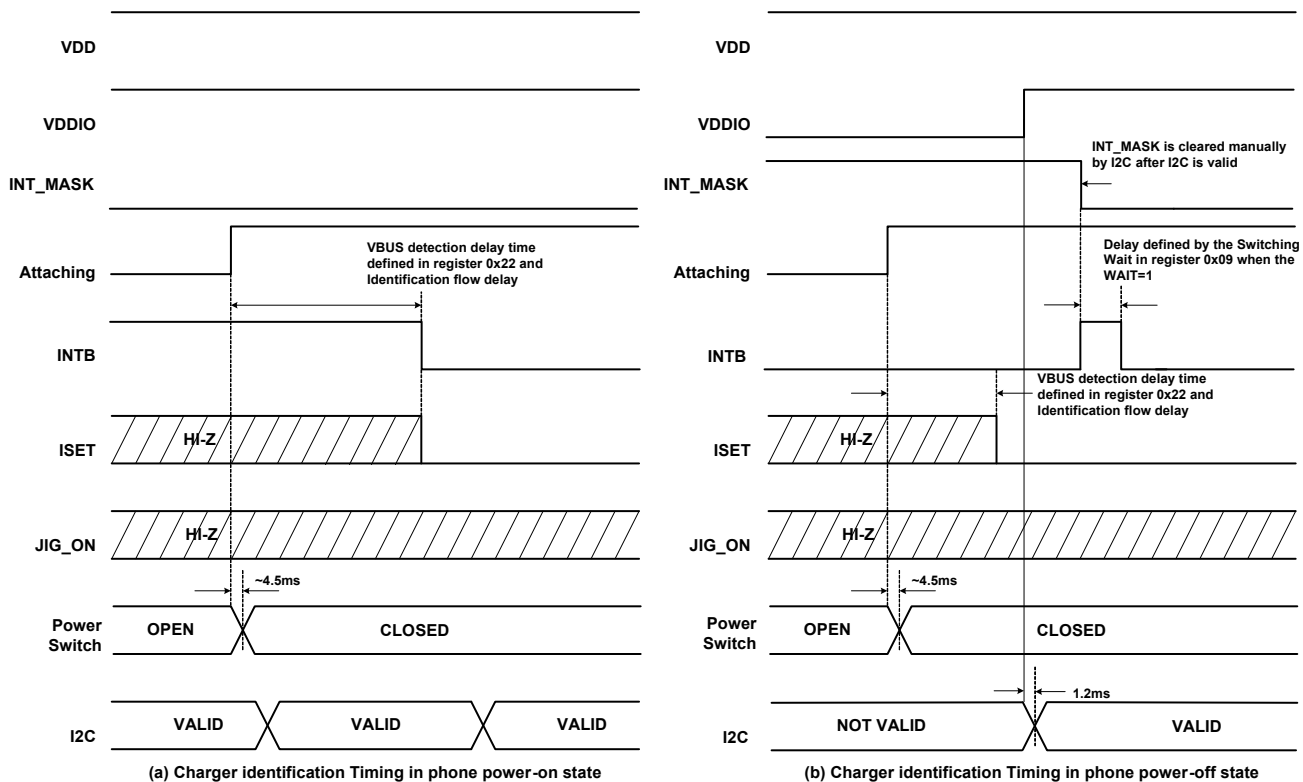

Figure 39. Charger Identification Timing Diagram

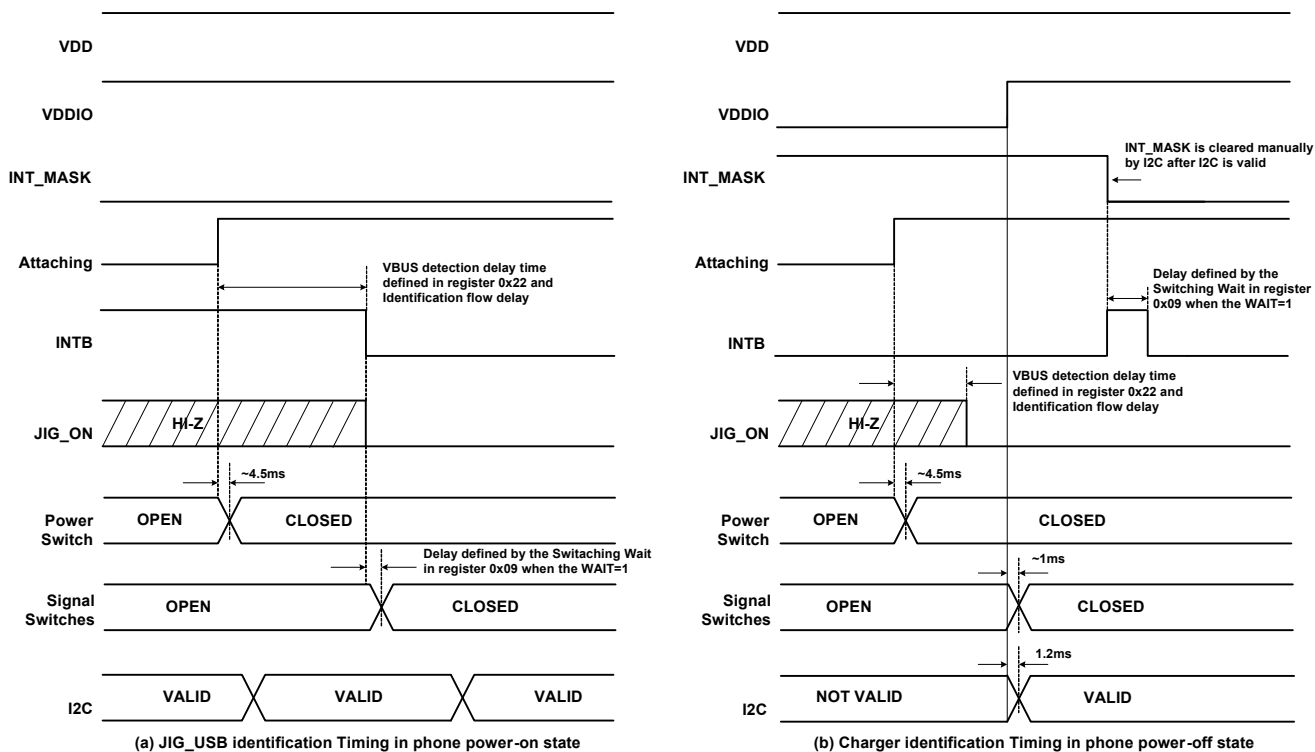

Figure 40. JIG USB cable Identification Timing Diagram

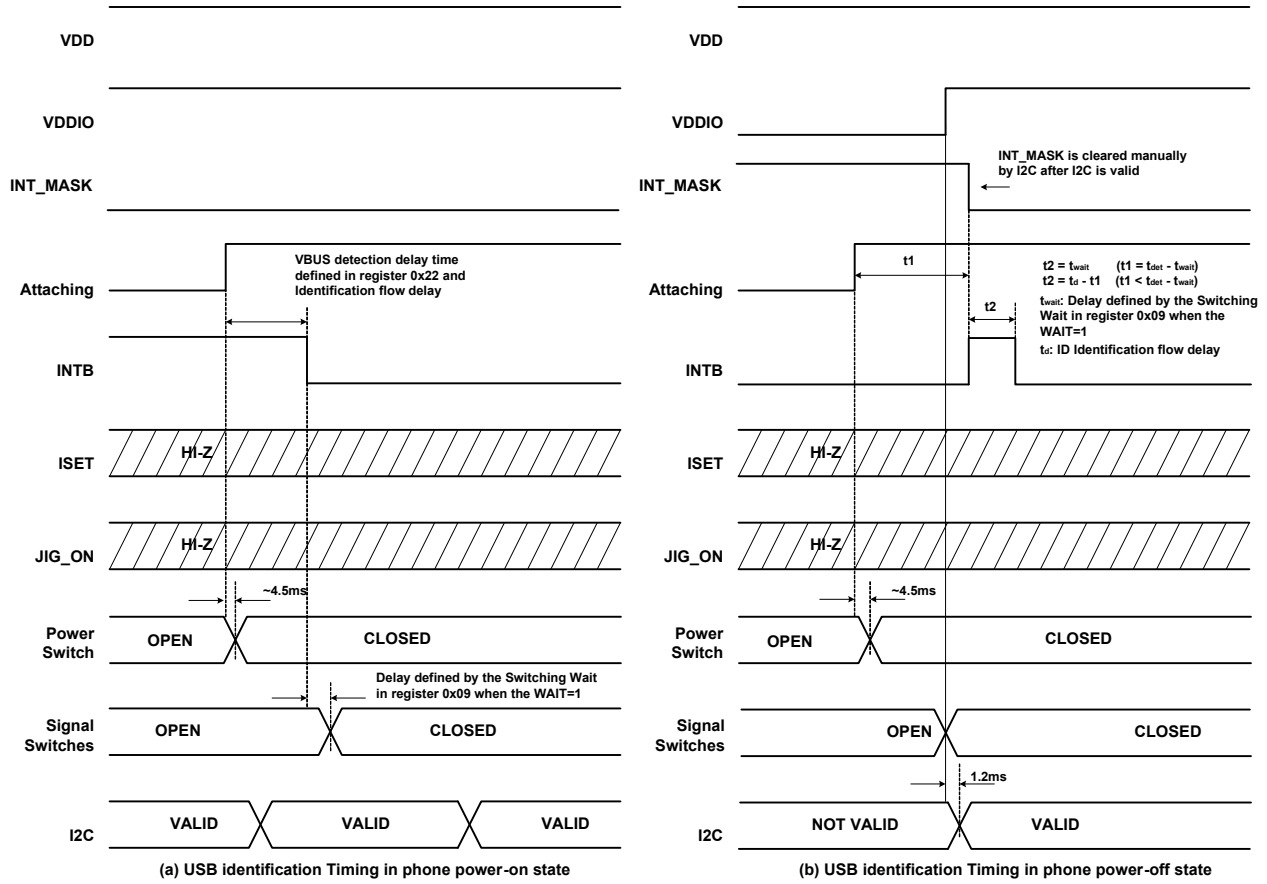

Figure 41. USB Host Identification Timing Diagram

TYPICAL APPLICATIONS

INTERFACE CIRCUIT IN A CELL PHONE

When the 34827 is used in a cell phone, the typical circuit is shown in the [Figure 42](#). The I²C bus need pull-up resistors. Typically they are 4.7 kΩ. When the audio outputs of the cell

phone baseband/application processor are direct-drive signals, the audio signals can go into the corresponding pins of 34827 directly. Otherwise these signals need DC-blocking capacitors to remove the DC level.

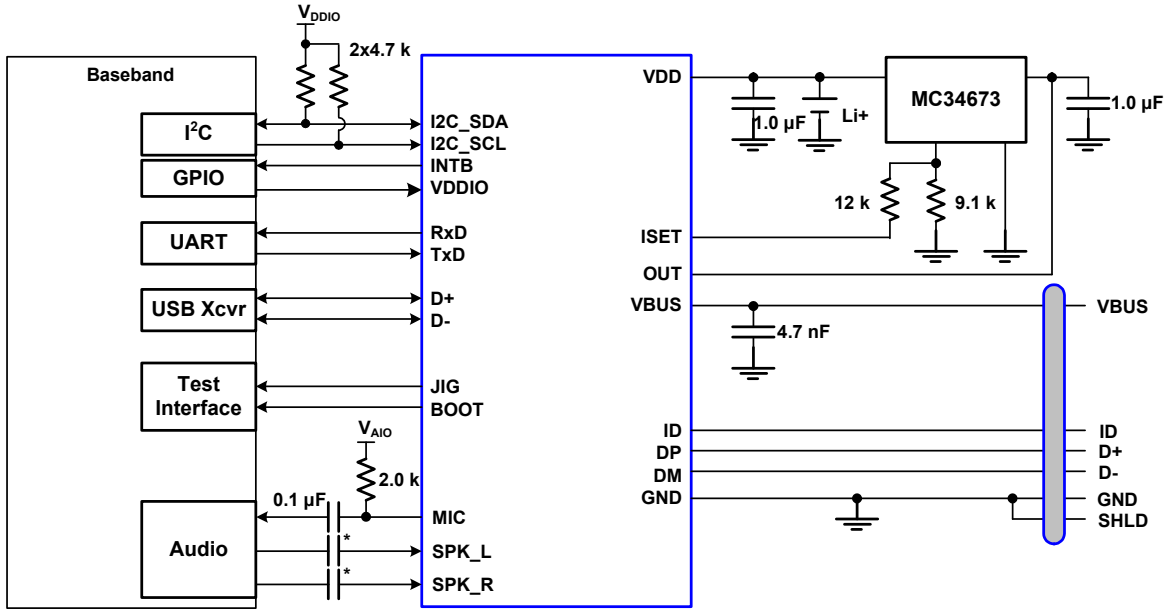

* : For direct-drive audio output, these DC blocking capacitors are not needed

Figure 42. Interface Circuit in a Cell Phone System

PACKAGE DIMENSIONS

For the most current package revision, visit www.freescale.com and perform a keyword search using the "98A" listed below.

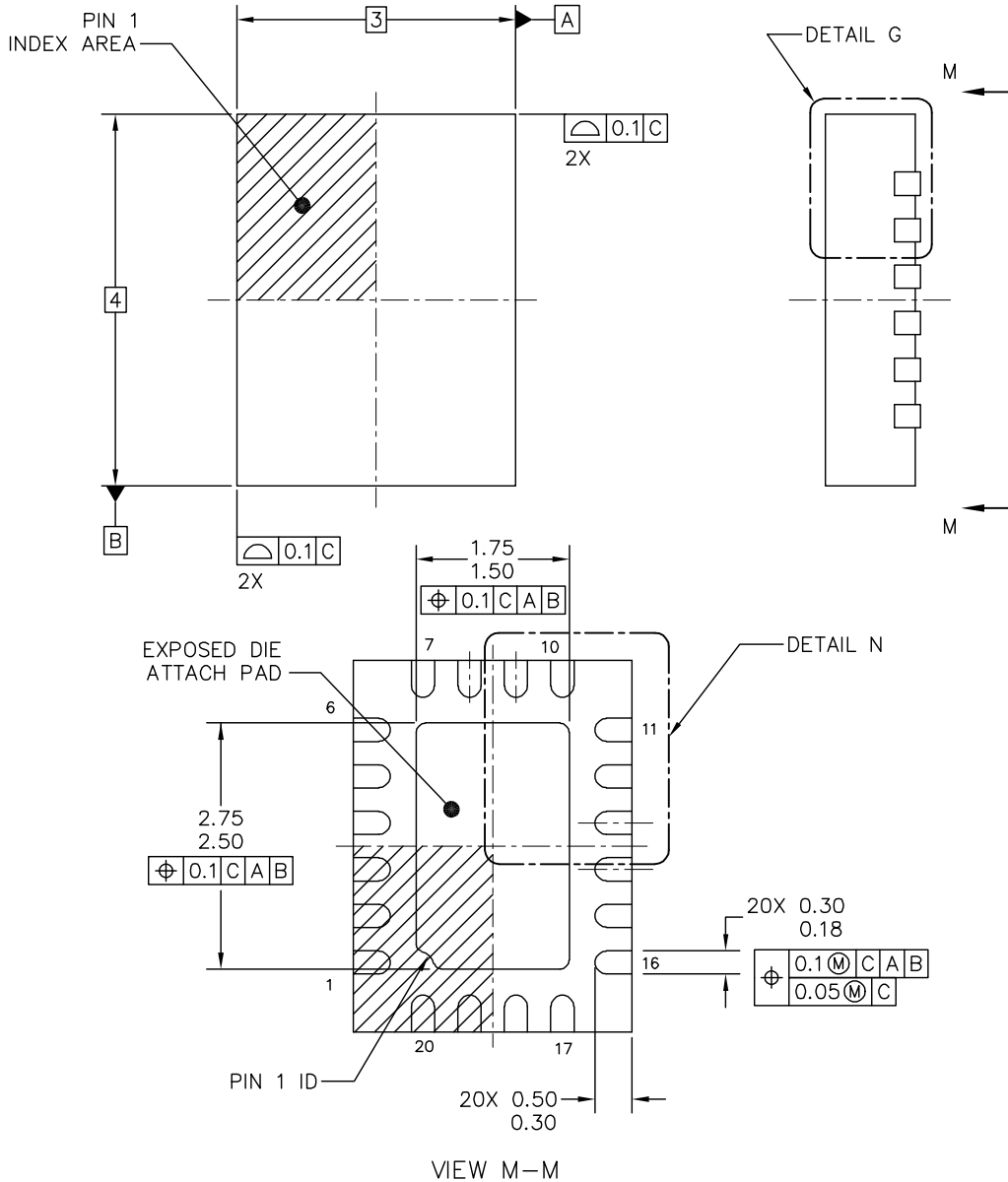

© FREESCALE SEMICONDUCTOR, INC. ALL RIGHTS RESERVED.	MECHANICAL OUTLINE	PRINT VERSION NOT TO SCALE	
TITLE: THERMALLY ENHANCED QUAD FLAT NON-LEADED PACKAGE (QFN) 20 TERMINAL, 0.50 PITCH (3 X 4 X 0.60) 1.75 X 2.75 EP, CASE OUTLINE	DOCUMENT NO: 98ASA00050D	REV: A	
	CASE NUMBER: 2072-01	16 FEB 2009	
	STANDARD: NON-JEDEC		

EP SUFFIX
20 PIN. QFN
98ASA00050D
REVISION A

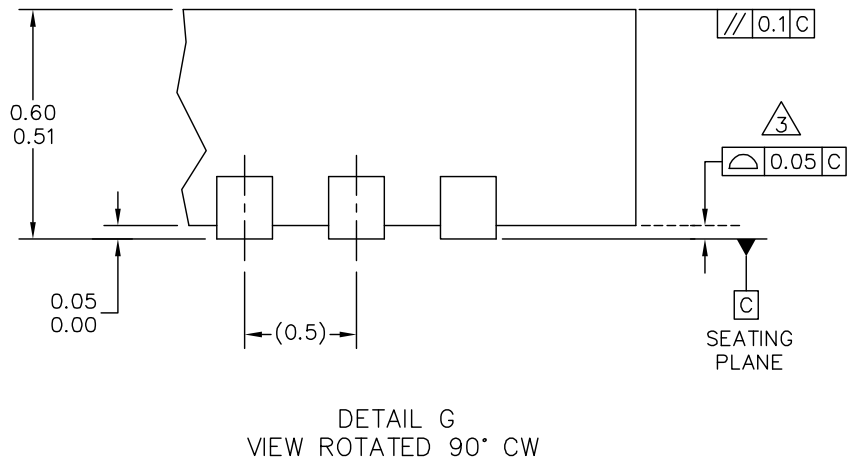
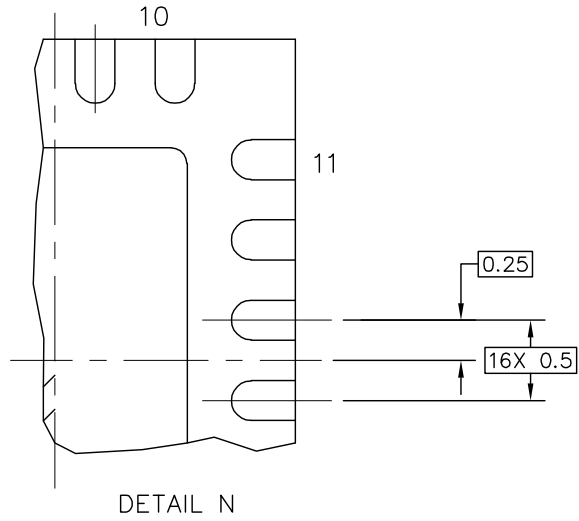

© FREESCALE SEMICONDUCTOR, INC. ALL RIGHTS RESERVED.	MECHANICAL OUTLINE	PRINT VERSION NOT TO SCALE	
TITLE: THERMALLY ENHANCED QUAD FLAT NON-LEADED PACKAGE (QFN) 20 TERMINAL, 0.50 PITCH (3 X 4 X 0.60) 1.75 X 2.75 EP, CASE OUTLINE	DOCUMENT NO: 98ASA00050D	REV: A	
	CASE NUMBER: 2072-01	16 FEB 2009	
	STANDARD: NON-JEDEC		

EP SUFFIX
20 PIN. QFN
98ASA00050D
REVISION A

NOTES:

1. ALL DIMENSIONS ARE IN MILLIMETERS.
2. DIMENSIONING AND TOLERANCING PER ASME Y14.5M-1994.
3.  COPLANARITY APPLIES TO LEADS AND DIE ATTACH PAD.
4. MIN. METAL GAP SHOULD BE 0.2M.

© FREESCALE SEMICONDUCTOR, INC. ALL RIGHTS RESERVED.	MECHANICAL OUTLINE	PRINT VERSION NOT TO SCALE	
TITLE: THERMALLY ENHANCED QUAD FLAT NON-LEADED PACKAGE (QFN) 20 TERMINAL, 0.50 PITCH (3 X 4 X 0.60) 1.75 X 2.75 EP, CASE OUTLINE	DOCUMENT NO: 98ASA00050D	REV: A	
	CASE NUMBER: 2072-01	16 FEB 2009	
	STANDARD: NON-JEDEC		

EP SUFFIX
20 PIN. QFN
98ASA00050D
REVISION A

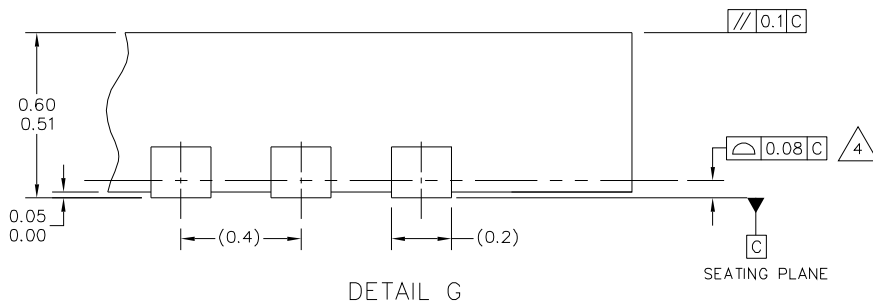

© FREESCALE SEMICONDUCTOR, INC. ALL RIGHTS RESERVED.	MECHANICAL OUTLINE	PRINT VERSION NOT TO SCALE	
TITLE: THERMALLY ENHANCED QUAD FLAT NO LEAD PACKAGE (QFN) 20 TERMINAL, 0.4 PITCH (3 X 3 X 0.6)	DOCUMENT NO: 98ASA00037D	REV: 0	
	CASE NUMBER: 2064-01	16 DEC 2008	
	STANDARD: NON JEDEC		

EP SUFFIX
20 PIN. QFN
98ASA00037D
REVISION 0

NOTES:

1. ALL DIMENSIONS ARE IN MILLIMETERS.
2. INTERPRET DIMENSIONS AND TOLERANCES PER ASME Y14.5M-1994.
3. THIS IS NON JEDEC REGISTERED PACKAGE.
4.  COPLANARITY APPLIES TO LEADS AND ALL OTHER BOTTOM SURFACE METALLIZATION.
5. MIN. METAL GAP SHOULD BE 0.2MM.

© FREESCALE SEMICONDUCTOR, INC. ALL RIGHTS RESERVED.	MECHANICAL OUTLINE	PRINT VERSION NOT TO SCALE	
TITLE: THERMALLY ENHANCED QUAD FLAT NO LEAD PACKAGE (QFN) 20 TERMINAL, 0.4 PITCH (3 X 3 X 0.6)	DOCUMENT NO: 98ASA00037D	REV: 0	
	CASE NUMBER: 2064-01	16 DEC 2008	
	STANDARD: NON JEDEC		

EP SUFFIX
20 PIN. QFN
98ASA00037D
REVISION 0

REVISION HISTORY

Revision	Date	Description of Changes
2.0	3/2011	<ul style="list-style-type: none">Initial release
3.0	6/2014	<ul style="list-style-type: none">No technical changes. Revised back page. Updated document properties. Added SMARTMOS sentence to last paragraph.



How to Reach Us:

Home Page:
freescale.com

Web Support:
freescale.com/support

Information in this document is provided solely to enable system and software implementers to use Freescale products. There are no express or implied copyright licenses granted hereunder to design or fabricate any integrated circuits based on the information in this document.

Freescale reserves the right to make changes without further notice to any products herein. Freescale makes no warranty, representation, or guarantee regarding the suitability of its products for any particular purpose, nor does Freescale assume any liability arising out of the application or use of any product or circuit, and specifically disclaims any and all liability, including without limitation consequential or incidental damages. "Typical" parameters that may be provided in Freescale data sheets and/or specifications can and do vary in different applications, and actual performance may vary over time. All operating parameters, including "typicals," must be validated for each customer application by customer's technical experts. Freescale does not convey any license under its patent rights nor the rights of others. Freescale sells products pursuant to standard terms and conditions of sale, which can be found at the following address: freescale.com/SalesTermsandConditions.

Freescale and the Freescale logo are trademarks of Freescale Semiconductor, Inc., Reg. U.S. Pat. & Tm. Off. SMARTMOS is a trademark of Freescale Semiconductor, Inc. All other product or service names are the property of their respective owners.

© 2014 Freescale Semiconductor, Inc.

Document Number: MC34827
Rev. 3.0
6/2014



X-ON Electronics

Largest Supplier of Electrical and Electronic Components

Click to view similar products for [USB Interface IC](#) category:

Click to view products by [NXP](#) manufacturer:

Other Similar products are found below :

[CY7C69356-48LTXC](#) [USB3319C-GJ-TR](#) [USB3370B-EZK-TR](#) [CYPD2120-24LQXI](#) [CYPD2122-20FNXIT](#) [CYPD2122-24LQXIT](#) [LIF-UC120-SWG36ITR50](#) [UPD360-A/6HX](#) [CP2102NP1174GM](#) [CG8454AM](#) [DPO2039DABQ-13](#) [CY7C68034-56LTXC](#) [TUSB213IRGYT](#) [TUSB213RGYT](#) [USB3503T-I/ML](#) [CY7C63310-SXC](#) [CY7C68013A-56LTXIT](#) [USB3316C-CP-TR](#) [USB3250-ABZJ](#) [FT220XS-R](#) [MAX3107ETG+](#) [MAX14632EZK+T](#) [USB3300-EZK](#) [LAN9514-JZX](#) [CYPD2120-24LQXIT](#) [MAX3100CEE+T](#) [USB5826-I/KD](#) [USB5826/KD](#) [USB5906/KD](#) [USB5916/KD](#) [USB5926/KD](#) [TUSB215QRGYTQ1](#) [TUSB522PRGER](#) [NB7NPQ701MMTTBG](#) [TUSB213RGYR](#) [USB5926-I/KD](#) [USB5906-I/KD](#) [USB4640I-HZH-03](#) [CY7C63813-SXC](#) [CY7C63823-SXC](#) [CY7C64215-28PVXC](#) [CY7C68013A-128AXC](#) [CY7C68013A-56LTXI](#) [CY7C68013A-56PVXC](#) [CY7C68013A-56PVXI](#) [CYPD1120-40LQXI](#) [AP43771VDKZ-13](#) [AP43771VFBZ-13](#) [DIO32320MP10](#) [HT42B534-2](#)