

MC9S08SU16 16 KB Flash

40 MHz S08L Based Microcontroller

MC9S08SU16 and MC9S08SU8 are low-cost, high-performance and high integration UHV HCS08 8-bit microcontroller units (MCU). It uses the enhanced S08L central processor unit with 3-phase MOSFET pre-drivers unit which supports 3 high-side PMOSes and 3 low-side NMOSes, amplifiers for current measurement, OCP (over current protection) and OVP (over voltage protection). It is put into a 4mm x 4mm 24-pin QFN package, targeting drone electrical speed controller, low power motor control, small form cooling fan control and portable tools.

MC9S08SU16VFK
MC9S08SU8VFK



24-pin QFN (FK)
4 x 4 x 0.65 Pitch 0.5 mm

Core

- S08L core up to 40 MHz
- Bus up to 20 MHz

Memories

- 16 KB program flash memory for SU16 and 8 KB program flash memory for SU8
- 768 byte SRAM, 256 B of which is unrestricted, the other 512 B is restricted during Flash erasing and programming
- 8 bytes regfile

System peripherals

- Windowed COP with multiple clock sources (watch dog)
- Inter module connection module
- CRC

Clocks

- External clock input
- 32 kHz tunable internal RC oscillator
- 20 kHz low power clock

Operating Characteristics

- Voltage range: 4.5 to 18 V
- Temperature range (ambient): -40 to 105°C

Human-machine interface

- 5 V input/output for logical I/O

Communication interfaces

- One SCI module
- One I2C module supporting SMBus communications interface

Analog Modules

- Two 12-bit ADC with up to 8 channels
- Analog comparator with up to 4 inputs and internal 6-bit DAC
- High voltage GDU

Timers

- Two 16-bit pulse width timers (PWT)
- Two programmable delay block (PDB)
- One 16-bit FTM
- One 16-bit modulo timer (MTIM)
- One 16-bit 6-channel PWM

Security and integrity modules

- 64-bit unique identification number per chip

Ordering information

Part Number	Memory		Maximum number of I/O's
	Flash (KB)	SRAM (Byte)	
MC9S08SU16VFK	16	768	17
MC9S08SU8VFK	8	768	17

Related resources

Type	Description	Resource
Selector Guide	The NXP Solution Advisor is a web-based tool that features interactive application wizards and a dynamic product selector.	Solution Advisor
Reference Manual	The Reference Manual contains a comprehensive description of the structure and function (operation) of a device. ¹	MC9S08SU16RM
Data Sheet	The Data Sheet includes electrical characteristics and signal connections.	MC9S08SU16 ¹
Chip Errata	The chip mask set Errata provides additional or corrective information for a particular device mask set.	xN88M ²
Package drawing	Package dimensions are provided in package drawings.	QFN 24-pin: 98ASA00602D

1. To find the associated resource, go to [nxp.com](#) and perform a search using this term.
2. To find the associated resource, go to [nxp.com](#) and perform a search using this term with the “x” replaced by the revision of the device you are using.

[Figure 1](#) shows the functional modules in the chip.

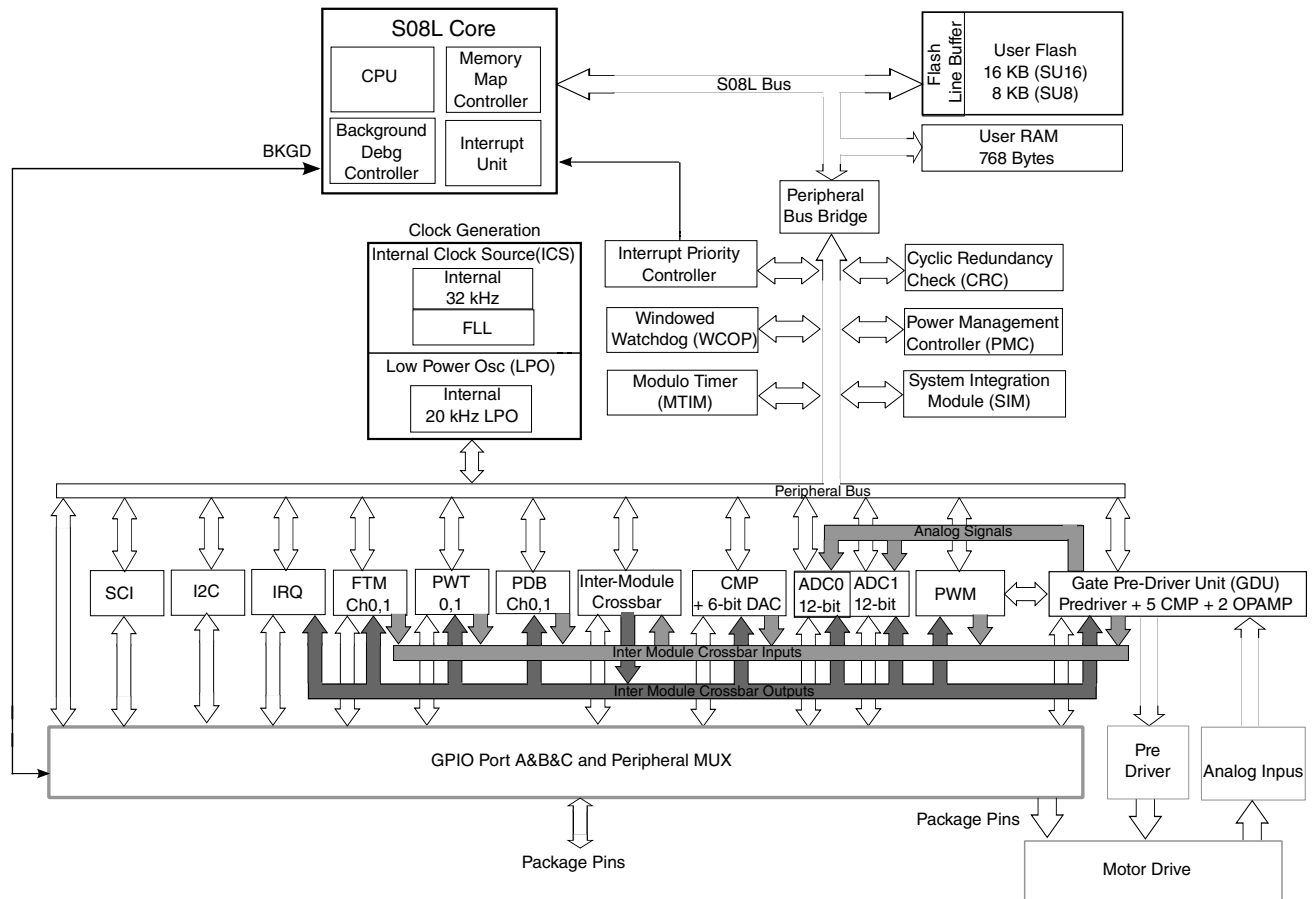

Figure 1. Functional block diagram

Table of Contents

1 Ratings.....	5	3.4.1 Inter-Integrated Circuit Interface (I2C) timing....	29
1.1 Thermal handling ratings.....	5	4 Dimensions.....	30
1.2 Moisture handling ratings.....	5	4.1 Obtaining package dimensions.....	30
1.3 ESD handling ratings.....	5	5 Pinout.....	30
1.4 Voltage and current operating ratings.....	6	5.1 Signal multiplexing and pin assignments.....	30
2 General.....	7	5.2 Pinout	32
2.1 Nonswitching electrical specifications.....	7	6 Part identification.....	32
2.1.1 DC characteristics.....	7	6.1 Description.....	32
2.1.2 Supply current characteristics.....	12	6.2 Format.....	33
2.1.3 EMC performance.....	14	6.3 Fields.....	33
2.2 Switching specifications.....	15	6.4 Example.....	33
2.2.1 Control timing.....	15	7 Terminology and guidelines.....	33
2.2.2 FTM module timing.....	16	7.1 Definition: Operating requirement.....	33
2.3 Thermal specifications.....	17	7.2 Definition: Operating behavior.....	34
2.3.1 Thermal operating requirements.....	17	7.3 Definition: Attribute.....	34
2.3.2 Thermal characteristics.....	18	7.4 Definition: Rating.....	35
3 Peripheral operating requirements and behaviors.....	18	7.5 Result of exceeding a rating.....	35
3.1 ICS characteristics.....	18	7.6 Relationship between ratings and operating requirements.....	36
3.2 NVM specifications.....	19	7.7 Guidelines for ratings and operating requirements.....	36
3.3 Analog.....	20	7.8 Definition: Typical value.....	36
3.3.1 ADC characteristics.....	20	7.9 Typical value conditions.....	37
3.3.2 CMP and 6-bit DAC electrical specifications.....	23	7.10 Parameter Classification.....	38
3.3.3 GDU characteristics.....	26	8 Revision history.....	38
3.4 Communication interfaces.....	29		

1 Ratings

1.1 Thermal handling ratings

Symbol	Description	Min.	Max.	Unit	Notes
T _{STG}	Storage temperature	-55	150	°C	1
T _{SDR}	Solder temperature, lead-free	—	260	°C	2

1. Determined according to JEDEC Standard JESD22-A103, *High Temperature Storage Life*.
2. Determined according to IPC/JEDEC Standard J-STD-020, *Moisture/Reflow Sensitivity Classification for Nonhermetic Solid State Surface Mount Devices*.

1.2 Moisture handling ratings

Symbol	Description	Min.	Max.	Unit	Notes
MSL	Moisture sensitivity level	—	3	—	1

1. Determined according to IPC/JEDEC Standard J-STD-020, *Moisture/Reflow Sensitivity Classification for Nonhermetic Solid State Surface Mount Devices*.

1.3 ESD handling ratings

Symbol	Description	Min.	Max.	Unit	Notes
V _{HBM}	Electrostatic discharge voltage, human body model	-2000	+2000	V	1
V _{CDM}	Electrostatic discharge voltage, charged-device model	-500	+500	V	2
I _{LAT}	Latch-up current at ambient temperature of 105°C	-100	+100	mA	

1. Determined according to JEDEC Standard JESD22-A114, *Electrostatic Discharge (ESD) Sensitivity Testing Human Body Model (HBM)*.
2. Determined according to JEDEC Standard JESD22-C101, *Field-Induced Charged-Device Model Test Method for Electrostatic-Discharge-Withstand Thresholds of Microelectronic Components*.

1.4 Voltage and current operating ratings

Absolute maximum ratings are stress ratings only, and functional operation at the maximum is not guaranteed. Stress beyond the limits specified in below table may affect device reliability or cause permanent damage to the device. For functional operating conditions, refer to the remaining tables in this document.

This device contains circuitry protecting against damage due to high static voltage or electrical fields; however, it is advised that normal precautions be taken to avoid application of any voltages higher than maximum-rated voltages to this high-impedance circuit. Reliability of operation is enhanced if unused inputs are tied to an appropriate logic voltage level (for instance, either V_{SS} or V_{DDX}) or the programmable pullup resistor associated with the pin is enabled.

Symbol	Description	Min.	Max.	Unit
V_{DD}	Supply voltage	4.5	18	V
V_{DDX}	Supply voltage to digital I/O drivers ¹	4.20	5.25	V
I_{DDX}	Maximum current into V_{DDX}	—	50	mA
V_{DIO}	Digital input voltage (except \overline{RESET} or true open drain pin PTA4 and PTA5)	-0.3	$V_{DDX}+0.3$	V
	Digital input voltage (true open drain pin PTA4 and PTA5)	-0.3	$V_{DDX}+0.3$	V
V_{AIO}	Analog ² , \overline{RESET} input voltage	-0.3	$V_{DDX}+0.3$	V
I_D	Instantaneous maximum current single pin limit (applies to all port pins)	-25	25	mA

1. See [Table 2](#) for detail.
2. All digital I/O pins, except open-drain pin PTA4 and PTA5, are internally clamped to V_{SS} and V_{DDX} . PTA4 and PTA5 is only clamped to V_{SS} .

2 General

2.1 Nonswitching electrical specifications

2.1.1 DC characteristics

This section includes information about power supply requirements and I/O pin characteristics.

Table 1. DC characteristics

Symbol	C	Descriptions			Min	Typical ¹	Max	Unit
—	—	Operating voltage			—	4.5	18	V
V _{OH}	P	Output high voltage	All I/O pins, standard-drive strength	5 V, I _{load} = -5 mA	V _{DDX} - 0.8	—	—	V
	P		High current drive pins, high-drive strength ²	5 V, I _{load} = -20 mA	V _{DDX} - 0.8	—	—	V
I _{OHT}	D	Output high current	Max total I _{OH} for all ports	5 V	—	—	-100	mA
V _{OL}	P	Output low voltage	All I/O pins, standard-drive strength	5 V, I _{load} = 5 mA	—	—	0.8	V
	P		High current drive pins, high-drive strength ²	5 V, I _{load} = 20 mA	—	—	0.8	V
I _{OLT}	D	Output low current	Max total I _{OL} for all ports	5 V	—	—	100	mA
V _{IH}	P	Input high voltage	All digital inputs	V _{DDX} > 4.5V	0.70 × V _{DDX}	—	—	V
	C			V _{DDX} > 2.7V	0.75 × V _{DDX}	—	—	V
V _{IL}	P	Input low voltage	All digital inputs	V _{DDX} > 4.5V	—	—	0.30 × V _{DDX}	V
	C			V _{DDX} > 2.7V	—	—	0.35 × V _{DDX}	V
V _{hys}	C	Input hysteresis	All digital inputs	—	0.06 × V _{DDX}	—	—	mV
I _{in}	P	Input leakage current	All input only pins (per pin)	V _{IN} = V _{DDX} or V _{SS}	—	0.1	1	μA
I _{OZTOT}	C	Total leakage combined for all inputs and Hi-Z pins	All input only and I/O	V _{IN} = V _{DDX} or V _{SS}	—	—	2	μA

Table continues on the next page...

Table 1. DC characteristics (continued)

Symbol	C	Descriptions			Min	Typical ¹	Max	Unit
R _{PU}	P	Pullup resistors	All digital inputs, when enabled (all I/O pins other than PTA4 and PTA5)	—	30.0	—	50.0	kΩ
R _{PU} ³	P	Pullup resistors	PTA4 and PTA5 pin	—	30.0	—	60.0	kΩ
R _{PD} ⁴	P	Pulldown resistors	PTB3, PTB4 and PTB5 pin	—	30	40	50	kΩ
I _{IC}	D	DC injection current ^{5, 6, 7}	Single pin limit	V _{IN} < V _{SS} , V _{IN} > V _{DDX}	-2	—	2	mA
			Total MCU limit, includes sum of all stressed pins		-5	—	25	
C _{In}	C	Input capacitance, all pins			—	—	7	pF
V _{RAM}	C	RAM retention voltage			—	—	—	V

1. Typical values are measured at 25 °C. Characterized, not tested.
2. Only PTB3, PTB4, PTB5, and PTB7 are high drive pins, and support ultra-high current output.
3. The specified resistor value is the actual value internal to the device. The pullup value may appear higher when measured externally on the pin.
4. The specified resistor value is the actual value internal to the device. The pulldown value may appear higher when measured externally on the pin.
5. All functional non-supply pins, except PTA4 and PTA5, are internally clamped to V_{SS} and V_{DDX}.
6. Input must be current-limited to the value specified. To determine the value of the required current-limiting resistor, calculate resistance values for positive and negative clamp voltages, then use the large one.
7. Power supply must maintain regulation within operating V_{DD} range during instantaneous and operating maximum current conditions. If the positive injection current (V_{IN} > V_{DD}) is higher than I_{DD}, the injection current may flow out of V_{DD} and could result in external power supply going out of regulation. Ensure that external V_{DD} load will shunt current higher than maximum injection current when the MCU is not consuming power, such as no system clock is present, or clock rate is very low (which would reduce overall power consumption).

Table 2. Power supply electrical characteristics

Symbol	Description	Min.	Typical ₁	Max.	Unit	
V _{DDX}	Output voltage V _{DDX}	Run mode 4.5 V ≤ V _{DD} < 5.3 V	4.20	—	5.25	V
		Run mode V _{DD} ≥ 5.3 V	4.75	4.99	5.25	V
		Stop mode ²	2.5	—	5.75	V
I _{DDX}	Load current V _{DDX}	Run mode 4.5V ≤ V _{DD} < 5.3 V	0	—	28	mA
		Run mode V _{DD} ≥ 5.3 V	0	—	50	mA
		Stop mode ²	0	—	5	mA
V _{REFH}	Output voltage V _{REFH}	V _{DD} ≥ 4.5 V	4.166	4.2 ³	4.234	V
—	V _{REFH} accuracy	V _{DD} ≥ V _{REFH} + 0.3, 0—70 °C	—	—	0.8	%
		V _{DD} ≥ V _{REFH} + 0.3, -40—105 °C	—	—	1.0	%
I _{REFH}	Output current V _{REFH}	V _{DD} ≥ V _{REFH} + 0.3	0	—	5	mA

Table continues on the next page...

Table 2. Power supply electrical characteristics (continued)

Symbol	Description	Min.	Typical ¹	Max.	Unit	
V _{LVWA}	V _{DDX} Low voltage warning assert level	PMC_LVCTLSTAT1[SLVWSEL] = 1b	3.43	3.63	3.83	V
		PMC_LVCTLSTAT1[SLVWSEL] = 0b	3.94	4.14	4.34	
V _{LVWD}	V _{DDX} Low voltage warning deassert level	PMC_LVCTLSTAT1[SLVWSEL] = 1b	3.54	3.74	3.94	V
		PMC_LVCTLSTAT1[SLVWSEL] = 0b	4.08	4.28	4.48	
V _{LVRA}	V _{DDX} low voltage reset assert	2.97	3.02	—	V	
V _{LVRD}	V _{DDX} low voltage reset deassertl	—	—	3.13	V	
V _{LVWREFHA}	Low voltage warning for V _{REFH} assert level ⁴	PMC_VREFHLVW[LVWCFG]=00b	3.34	3.54	3.74	V
		PMC_VREFHLVW[LVWCFG]=01b	3.43	3.63	3.83	V
		PMC_VREFHLVW[LVWCFG]=10b	3.86	4.06	4.26	V
		PMC_VREFHLVW[LVWCFG]=11b	4.11	4.31	4.51	V
V _{LVWREFHA}	Low voltage warning for V _{REFH} deassert level ⁴	PMC_VREFHLVW[LVWCFG]=00b	3.45	3.65	3.85	V
		PMC_VREFHLVW[LVWCFG]=01b	3.55	3.75	3.95	V
		PMC_VREFHLVW[LVWCFG]=10b	4.00	4.20	4.40	V
		PMC_VREFHLVW[LVWCFG]=11b	4.27	4.47	4.67	V
f _{LPOCLK}	Trimmed LPOCLK output frequency	—	20	—	kHz	
df _{LPOCLK}	Trimmed LPOCLK internal clock Δf / f _{NOMINAL} ⁵	-5	—	5	%	
t _{SDEL}	LPOCLK start up delay	—	25	50	μs	
dV _{HT}	Temperature sensor slope	—	5.07	—	mV/°C	
V _{HT}	Temperature sensor output voltage	—	1.73	—	V	
T _{HTIA}	High temperature interrupt assert ⁶	110	130	150	°C	
T _{HTID}	High temperature interrupt deassert ⁶	100	120	140	°C	
V _{BG}	Bandgap output voltage	1.13	1.2	1.32	V	
V _{HCBG}	HC Bandgap output voltage	1.14	1.15	1.16	V	
t _{STP_REC}	Recovery time from Stop	not including V _{REFH}	—	15	—	μs
		including V _{REFH}	—	1	—	ms

1. Typical values are measured at 25 °C.
2. Power supply enters reduced power mode when MCU is in Stop mode.
3. This typical value is configurable based on V_{REC}.
4. PMC_VREFHLVW[LVWCFG]=01b is recommended for the configuration.
5. User need to trim the LPOCLK in order to get ±5% LPOCLK
6. This is junction temperature.

Figure 2 illustrates the power distribution of this chip.

Nonswitching electrical specifications

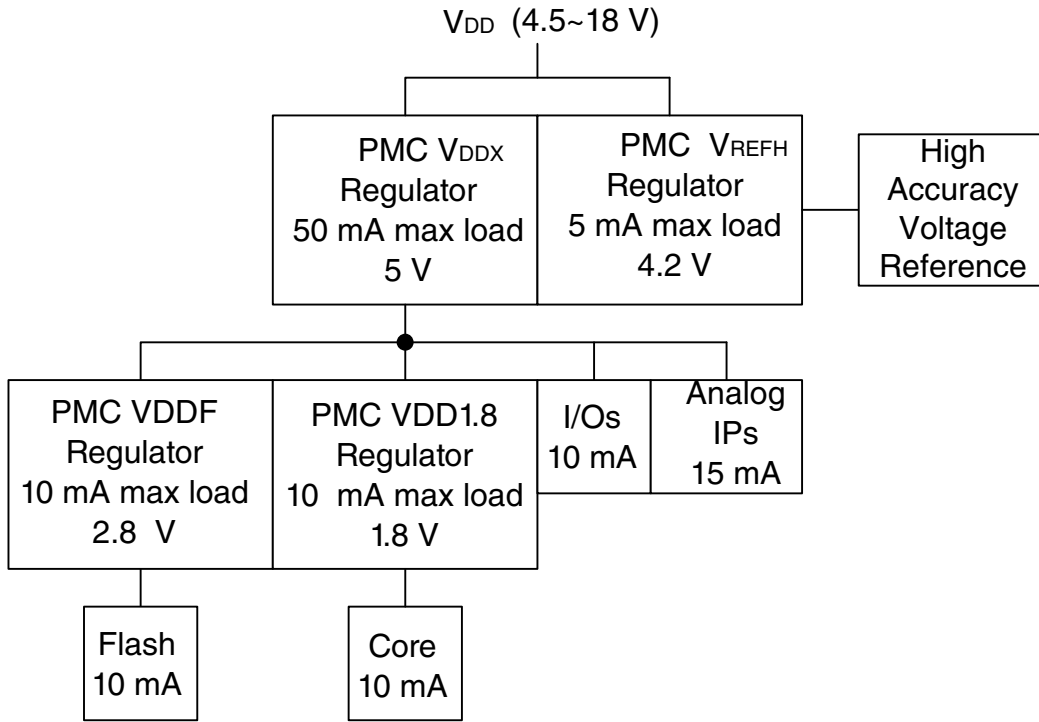

Figure 2. Power distribution

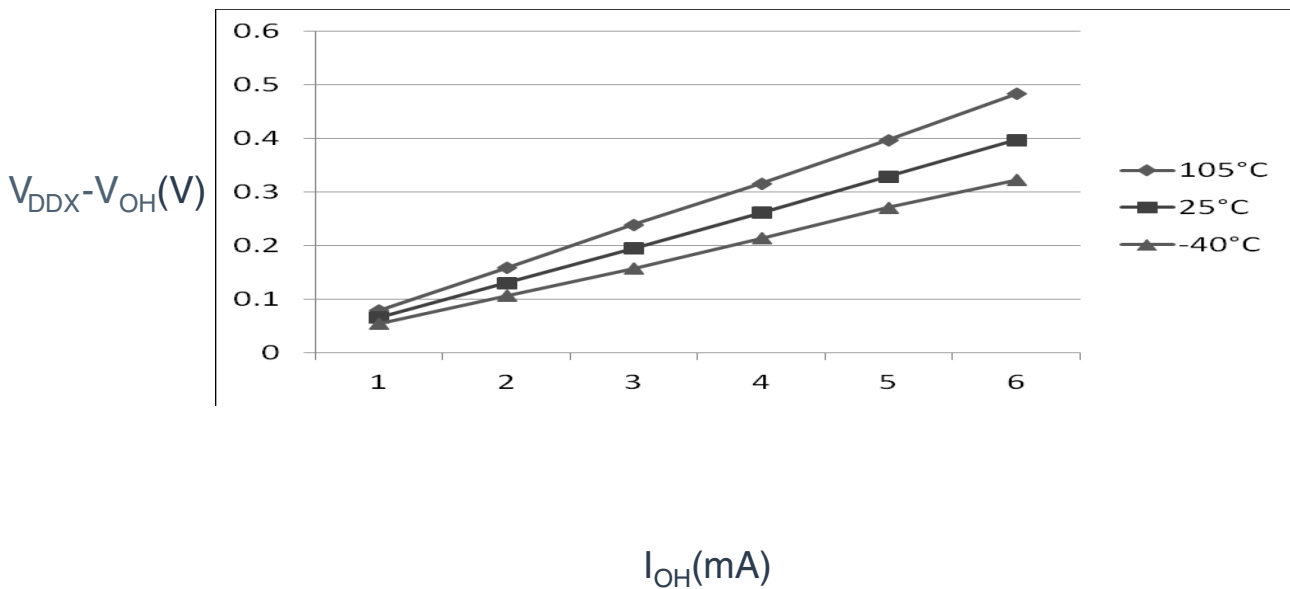

Figure 3. Typical I_{OH} Vs. $V_{DDX} - V_{OH}$ (standard drive strength) ($V_{DDX} = 5$ V)

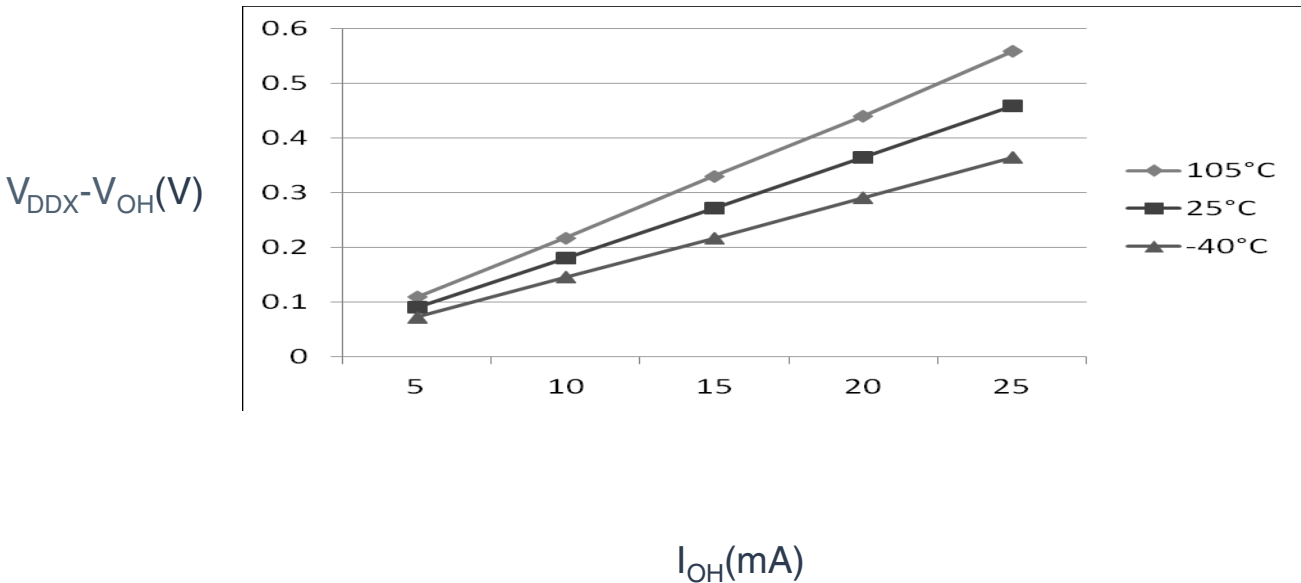

Figure 4. Typical I_{OH} Vs. $V_{DDX} - V_{OH}$ (high drive strength) ($V_{DDX} = 5\text{ V}$)

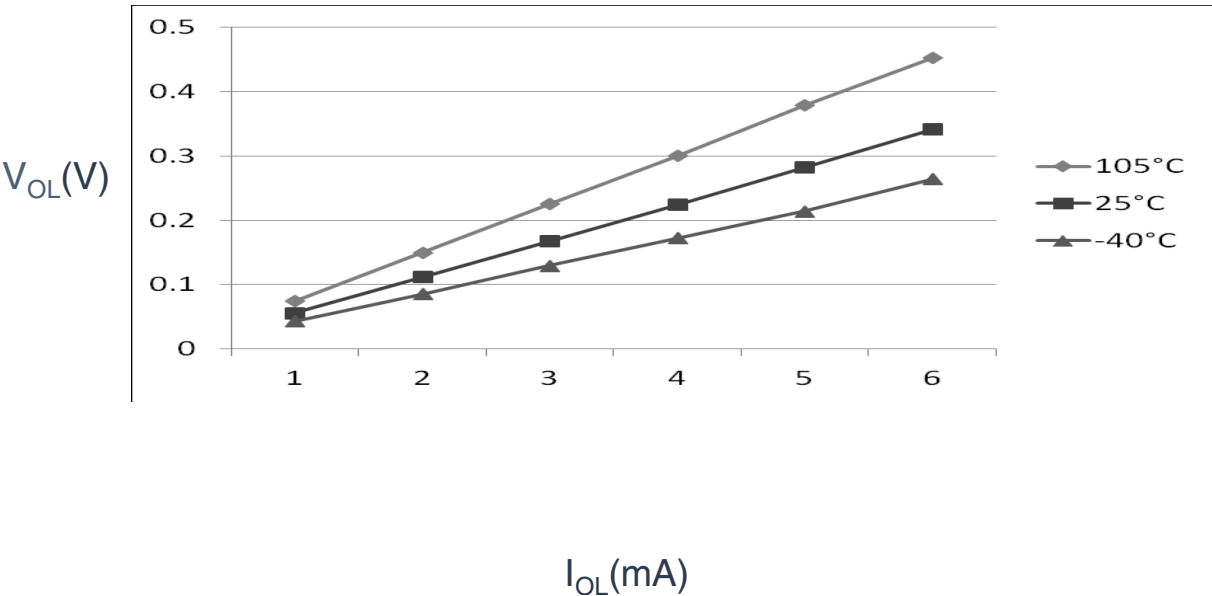

Figure 5. Typical I_{OL} Vs. V_{OL} (standard drive strength) ($V_{DDX} = 5\text{ V}$)

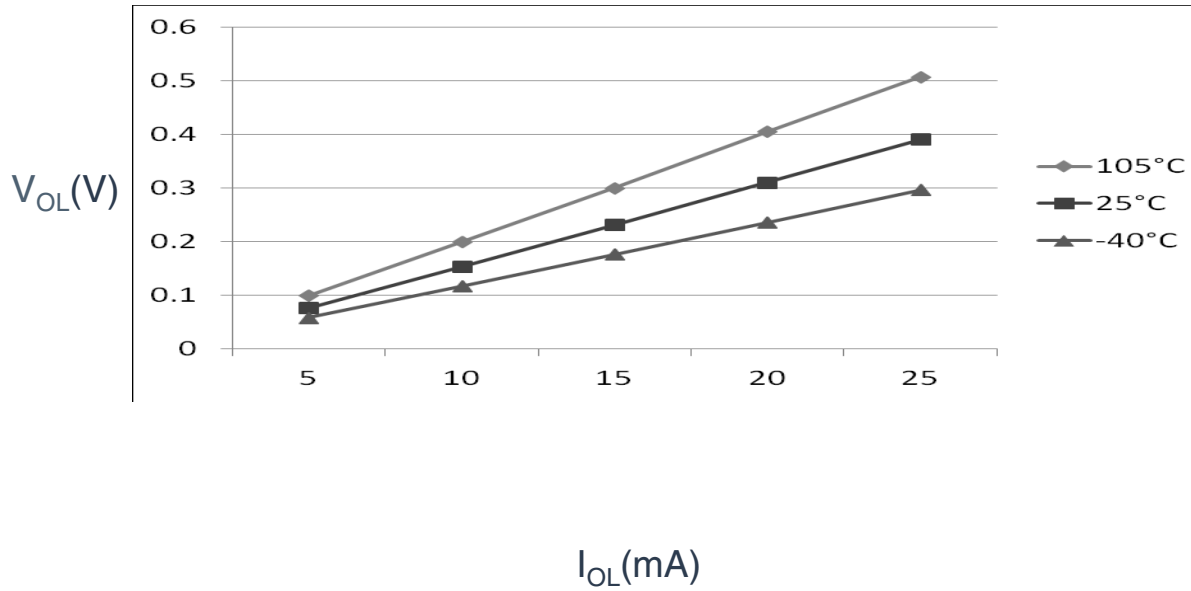

Figure 6. Typical I_{OL} Vs. V_{OL} (high drive strength) ($V_{DDX} = 5\text{ V}$)

2.1.2 Supply current characteristics

This section includes information about power supply current in various operating modes.

Table 3. Supply current characteristics

C	Parameter	Symbol	Core/Bus Freq	V_{DD} (V)	Typical ¹	Max	Unit	Temp
C	Run supply current, FEI mode, all clock gate is off, code run from flash	R_{IDD}	40/20 MHz	18	11.00	—	mA	-40 to 105 °C
C			20/10 MHz		7.50	—		
C			20/1 MHz		6.00	—		
C			20/20 MHz	12	9.15	—		
C			20/10 MHz		7.50	—		
C			20/1 MHz		5.95	—		
C			20/20 MHz	5.3	9.10	—		
C			20/10 MHz		7.45	—		
C			20/1 MHz		5.90	—		
C			20/20 MHz	4.5	9.35	—		
C			20/10 MHz		7.65	—		
C			20/1 MHz		6.15	—		

Table continues on the next page...

Table 3. Supply current characteristics (continued)

C	Parameter	Symbol	Core/Bus Freq	V _{DD} (V)	Typical ¹	Max	Unit	Temp
C	Run supply current, FEI mode, all clock gate is on, code run from flash	R _{IDD}	40/20 MHz	18	13.05	—	mA	-40 to 105 °C
C			20/10 MHz		8.45	—		
C			20/1 MHz		6.05	—		
C			20/20 MHz	12	11.00	—		
C			20/10 MHz		8.40	—		
C			20/1 MHz		6.00	—		
C			20/20 MHz	5.3	10.95	—		
C			20/10 MHz		8.35	—		
C			20/1 MHz		6.00	—		
C			20/20 MHz	4.5	11.20	—		
C			20/10 MHz		8.60	—		
C			20/1 MHz		6.20	—		
C	Run supply current, FBE mode, all clock gate is off, code run from SRAM	R _{IDD}	40/20 MHz	18	9.60	—	mA	-40 to 105 °C
C			20/10 MHz		6.05	—		
C			20/1 MHz		4.50	—		
C			20/20 MHz	12	7.80	—		
C			20/10 MHz		6.05	—		
C			20/1 MHz		4.45	—		
C			20/20 MHz	5.3	7.75	—		
C			20/10 MHz		6.00	—		
C			20/1 MHz		4.40	—		
C			20/20 MHz	4.5	7.90	—		
C			20/10 MHz		6.20	—		
C			20/1 MHz		4.60	—		
C	Run supply current, FBE mode, all clock gate is on, code run from SRAM	R _{IDD}	40/20 MHz	18	11.65	—	mA	-40 to 105 °C
C			20/10 MHz		7.00	—		
C			20/1 MHz		4.60	—		
C			20/20 MHz	12	9.60	—		
C			20/10 MHz		6.95	—		
C			20/1 MHz		4.55	—		
C			20/20 MHz	5.3	9.60	—		
C			20/10 MHz		6.90	—		
C			20/1 MHz		4.50	—		
C			20/20 MHz	4.5	9.75	—		
C			20/10 MHz		7.10	—		
C			20/1 MHz		4.70	—		
C	Wait mode current, FEI mode, all clock gate is on	W _{IDD}	40/20 MHz	18	7.80	—	mA	-40 to 105 °C

Table continues on the next page...

Table 3. Supply current characteristics (continued)

C	Parameter	Symbol	Core/Bus Freq	V _{DD} (V)	Typical ¹	Max	Unit	Temp
C			20/10 MHz		6.05	—		
			20/1 MHz		4.40	—		
C			20/20 MHz	12	7.70	—		
			20/10 MHz		6.00	—		
			20/1 MHz		4.40	—		
			20/20 MHz	5.3	7.65	—		
			20/10 MHz		5.95	—		
			20/1 MHz		4.35	—		
			20/20 MHz	4.5	7.85	—		
			20/10 MHz		6.20	—		
			20/1 MHz		4.60	—		
C	Stop mode supply current, no clocks active (except 20 kHz LPO clock)	SI _{DD}	—	18	19.85	—	μA	-40 to 105 °C
C			12	19.05	—			
C			5.3	18.25	—			
C			4.5	17.65	—			
C	ADC adder to Stop	—	—	18	88.80	—	μA	-40 to 105 °C
C	ADLPC = 1	12	87.95	—				
C	ADLSMP = 1	5.3	86.70	—				
C	ADCO = 1	4.5	85.40	—				

1. Data in Typical column was characterized at 25 °C or is typical recommended value.

2.1.3 EMC performance

Electromagnetic compatibility (EMC) performance is highly dependant on the environment in which the MCU resides. Board design and layout, circuit topology choices, location and characteristics of external components as well as MCU software operation all play a significant role in EMC performance. The system designer should consult Freescale applications notes such as AN2321, AN1050, AN1263, AN2764, and AN1259 for advice and guidance specifically targeted at optimizing EMC performance.

2.1.3.1 EMC radiated emissions operating behaviors

NOTE

If using external reset switch to design hardware board, connect two 0.1 μF decoupling capacitors on $\overline{\text{RESET}}$ pin for

EMC-sensitive applications. One is near the $\overline{\text{RESET}}$ pin and the other is near the reset switch.

Table 4. EMC radiated emissions operating behaviors for 24-pin QFN package

Symbol	Description	Frequency band (MHz)	Typ.	Unit	Notes
V _{RE1}	Radiated emissions voltage, band 1	0.15–50	4	dB μ V	1, 2
V _{RE2}	Radiated emissions voltage, band 2	50–150	3	dB μ V	
V _{RE3}	Radiated emissions voltage, band 3	150–500	3	dB μ V	
V _{RE4}	Radiated emissions voltage, band 4	500–1000	4	dB μ V	
V _{RE_IEC}	IEC/SAE level	0.15–1000	0	—	2, 3

1. Determined according to IEC Standard 61967-1, *Integrated Circuits - Measurement of Electromagnetic Emissions, 150 kHz to 1 GHz Part 1: General Conditions and Definitions* and IEC Standard 61967-2, *Integrated Circuits - Measurement of Electromagnetic Emissions, 150 kHz to 1 GHz Part 2: Measurement of Radiated Emissions—TEM Cell and Wideband TEM Cell Method*. Measurements were made while the microcontroller was running basic application code. The reported emission level is the value of the maximum measured emission, rounded up to the next whole number, from among the measured orientations in each frequency range.
2. V_{DD} = 12.0 V, T_A = 25 °C, f_{sys} = 40 MHz, f_{bus} = 20 MHz
3. Specified according to Annex D of IEC Standard 61967-2, *Measurement of Radiated Emissions—TEM Cell and Wideband TEM Cell Method*

2.2 Switching specifications

2.2.1 Control timing

Table 5. Control timing

C	Rating	Symbol	Min	Typical ¹	Max	Unit
P	Bus frequency (t _{cyc} = 1/f _{Bus})	f _{Bus}	DC	—	20	MHz
P	Internal low power oscillator frequency	f _{LPO}	19	20	21	KHz
D	External reset pulse width ²	t _{extrst}	100	—	—	ns
D	BKGD/MS setup time after issuing background debug force reset to enter user or BDM modes	t _{MSSU}	500	—	—	ns
D	BKGD/MS hold time after issuing background debug force reset to enter user or BDM modes ³	t _{MSH}	100	—	—	ns
D	IRQ pulse width	Asynchronous path ²	t _{LIH}	100	—	ns
D		Synchronous path ⁴	t _{HIH}	1.5 × t _{cyc}	—	ns
D	Keyboard interrupt pulse width	Asynchronous path ²	t _{LIH}	100	—	ns
D		Synchronous path	t _{HIH}	1.5 × t _{cyc}	—	ns

Table continues on the next page...

Table 5. Control timing (continued)

C	Rating	Symbol	Min	Typical ¹	Max	Unit
C	Port rise and fall time - Normal drive strength (HDRVE_PTXX = 0) (load = 50 pF) ⁵	t_{Rise}	—	10.2	—	ns
C		t_{Fall}	—	9.5	—	ns
C	Port rise and fall time - Extreme high drive strength (HDRVE_PTXX = 1) (load = 50 pF) ⁵	t_{Rise}	—	5.4	—	ns
C		t_{Fall}	—	4.6	—	ns

1. Typical values are based on characterization data at $V_{DDX} = 5.0\text{ V}$, $25\text{ }^{\circ}\text{C}$ unless otherwise stated.
2. This is the shortest pulse that is guaranteed to be recognized as a reset pin request.
3. To enter BDM mode following a POR, BKGD/MS must be held low during the powerup and for a hold time of t_{MSH} after V_{DDX} rises above V_{LVD} .
4. This is the minimum pulse width that is guaranteed to pass through the pin synchronization circuitry. Shorter pulses may or may not be recognized. In stop mode, the synchronizer is bypassed so shorter pulses can be recognized.
5. Timing is shown with respect to 20% V_{DDX} and 80% V_{DDX} levels. Temperature range $-40\text{ }^{\circ}\text{C}$ to $105\text{ }^{\circ}\text{C}$.

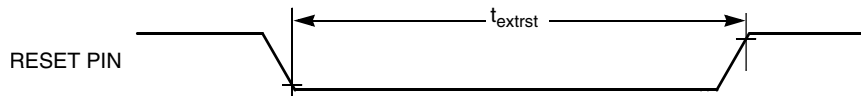

Figure 7. Reset timing

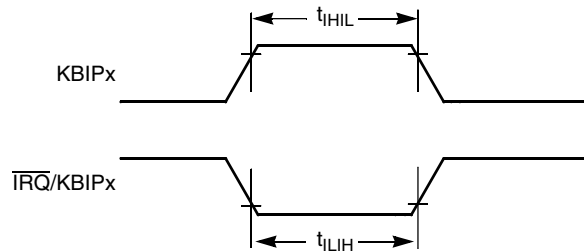

Figure 8. IRQ/KBIPx timing

2.2.2 FTM module timing

Synchronizer circuits determine the shortest input pulses that can be recognized or the fastest clock that can be used as the optional external source to the timer counter. These synchronizers operate from the current bus rate clock.

Table 6. FTM input timing

No.	C	Function	Symbol	Min	Max	Unit
1	D	External clock frequency	f_{TCLK}	0	$f_{Bus}/4$	Hz
2	D	External clock period	t_{TCLK}	4	—	t_{cyc}

Table continues on the next page...

Table 6. FTM input timing (continued)

No.	C	Function	Symbol	Min	Max	Unit
3	D	External clock high time	t_{clkh}	1.5	—	t_{cyc}
4	D	External clock low time	t_{clkl}	1.5	—	t_{cyc}
5	D	Input capture pulse width	t_{ICPW}	1.5	—	t_{cyc}

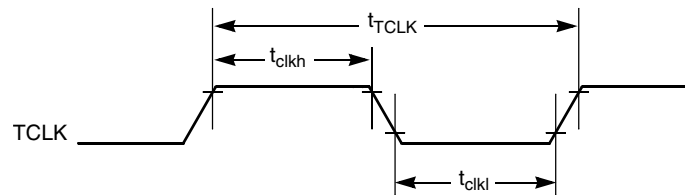
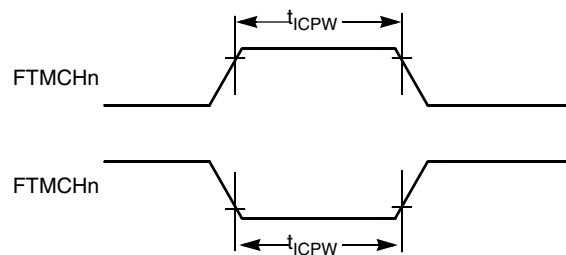
**Figure 9. Timer external clock****Figure 10. Timer input capture pulse**

2.3 Thermal specifications

2.3.1 Thermal operating requirements

Table 7. Thermal operating requirements

Symbol	Description	Min.	Max.	Unit	Note
T_J	Die junction temperature	-40	125	°C	
T_A	Ambient temperature	-40	105	°C	1

1. Maximum T_A can be exceeded only if the user ensures that T_J does not exceed the maximum. The simplest method to determine T_J is: $T_J = T_A + R_{\theta JA} \times \text{chip power dissipation}$.

2.3.2 Thermal characteristics

This section provides information about operating temperature range, power dissipation, and package thermal resistance. Power dissipation on I/O pins is usually small compared to the power dissipation in on-chip logic and voltage regulator circuits, and it is user-determined rather than being controlled by the MCU design. To take $P_{I/O}$ into account in power calculations, determine the difference between actual pin voltage and V_{SS} or V_{DDX} and multiply by the pin current for each I/O pin. Except in cases of unusually high pin current (heavy loads), the difference between pin voltage and V_{SS} or V_{DDX} will be very small.

Table 8. Thermal attributes

Board type	Symbol	Description	24-pin QFN	Unit	Notes
Single-layer (1S)	$R_{\theta JA}$	Thermal resistance, junction to ambient (natural convection)	114	°C/W	1, 2
Four-layer (2s2p)	$R_{\theta JA}$	Thermal resistance, junction to ambient (natural convection)	42	°C/W	1, 3
Single-layer (1S)	$R_{\theta JMA}$	Thermal resistance, junction to ambient (200 ft./min. air speed)	96	°C/W	1, 3
Four-layer (2s2p)	$R_{\theta JMA}$	Thermal resistance, junction to ambient (200 ft./min. air speed)	36	°C/W	1, 3
—	$R_{\theta JB}$	Thermal resistance, junction to board	19	°C/W	4
—	$R_{\theta JC}$	Thermal resistance, junction to case	3.4	°C/W	5
—	Ψ_{JT}	Thermal characterization parameter, junction to package top outside center (natural convection)	15	°C/W	6

1. Junction temperature is a function of die size, on-chip power dissipation, package thermal resistance, mounting site (board) temperature, ambient temperature, air flow, power dissipation of other components on the board, and board thermal resistance.
2. Per JEDEC JESD51-2 with the single layer board (JESD51-3) horizontal.
3. Per JEDEC JESD51-6 with the board (JESD51-7) horizontal.
4. Thermal resistance between the die and the printed circuit board per JEDEC JESD51-8. Board temperature is measured on the top surface of the board near the package.
5. Thermal resistance between the die and the solder pad on the bottom of the package. Interface resistance is ignored.
6. Thermal characterization parameter indicating the temperature difference between package top and the junction temperature per JEDEC JESD51-2. When Greek letters are not available, the thermal characterization.

3 Peripheral operating requirements and behaviors

3.1 ICS characteristics

Table 9. ICS specifications (temperature range = -40 to 105 °C ambient)

C	Characteristic		Symbol	Min	Typical ¹	Max	Unit
T	Internal reference start-up time		t_{IRST}	—	20	50	μ s
D	Square wave input clock frequency	FEE or FBE mode ²	f_{extal}	0.03125	—	5	MHz
D		FBELP mode		0	—	40	MHz
P	Average internal reference frequency - trimmed		$f_{\text{int_t}}$	—	39.0625	—	kHz
P	DCO output frequency range - trimmed		$f_{\text{dco_t}}$	16	—	40	MHz
P	Total deviation of DCO output from trimmed frequency ³	Over full voltage and temperature range	$\Delta f_{\text{dco_t}}$	—	—	± 2.0	% f_{dco}
C		Over fixed voltage and temperature range of 0 to 70 °C				± 1.0	
C	FLL acquisition time ^{3, 4}		t_{Acquire}	—	—	2	ms
C	Long term jitter of DCO output clock (averaged over 2 ms interval) ⁵		C_{Jitter}	—	0.02	0.2	% f_{dco}

1. Data in Typical column was characterized at $V_{\text{DDX}} = 5.0 \text{ V}$, 25 °C or is typical recommended value.
2. When ICS is configured for FEE or FBE mode, input clock source must be divisible using RDIV to within the range of 31.25 kHz to 39.0625 kHz.
3. This parameter is characterized and not tested on each device.
4. This specification applies to any time the FLL reference source or reference divider is changed, trim value changed, DMX32 bit is changed, DRS bit is changed, or changing from FLL disabled (FBELP, FBILP) to FLL enabled (FEI, FEE, FBE, FBI). If a crystal/resonator is being used as the reference, this specification assumes it is already running.
5. Jitter is the average deviation from the programmed frequency measured over the specified interval at maximum f_{Bus} . Measurements are made with the device powered by filtered supplies and clocked by a stable external clock signal. Noise injected into the FLL circuitry via V_{DDX} and V_{SS} and variation in crystal oscillator frequency increase the C_{Jitter} percentage for a given interval.

3.2 NVM specifications

This section provides details about program/erase times and program/erase endurance for the flash memories.

Table 10. Flash characteristics

C	Characteristic	Symbol	Min ¹	Typical ²	Max ³	Unit ⁴
D	NVM Bus frequency	f_{NVMBUS}	1	—	20	MHz
D	NVM Operating frequency	f_{NVMOP}	0.8	1	1.05	MHz
D	Erase Verify All Blocks	t_{VFYALL}	—	—	2605	t_{cyc}
D	Erase Verify Flash Block	t_{RD1BLK}	—	—	2579	t_{cyc}
D	Erase Verify Flash Section	t_{RD1SEC}	—	—	485	t_{cyc}
D	Read Once	t_{RDONCE}	—	—	464	t_{cyc}

Table continues on the next page...

Table 10. Flash characteristics (continued)

C	Characteristic	Symbol	Min ¹	Typical ²	Max ³	Unit ⁴
D	Program Flash (2 word)	t _{PGM2}	0.12	0.13	0.31	ms
D	Program Flash (4 word)	t _{PGM4}	0.21	0.21	0.49	ms
D	Program Once	t _{PGMONCE}	0.20	0.21	0.21	ms
D	Erase All Blocks	t _{ERSALL}	95.42	100.18	100.30	ms
D	Erase Flash Block	t _{ERSBLK}	95.42	100.18	100.30	ms
D	Erase Flash Sector	t _{ERSPG}	19.10	20.05	20.09	ms
D	Unsecure Flash	t _{UNSECU}	95.42	100.19	100.31	ms
D	Verify Backdoor Access Key	t _{VFYKEY}	—	—	482	t _{cyc}
D	Set User Margin Level	t _{MLOADU}	—	—	415	t _{cyc}
C	FLASH Program/erase endurance T _L to T _H = -40 °C to 105 °C	n _{FLPE}	10 k	100 k	—	Cycles
C	Data retention at an average junction temperature of T _{Javg} = 85°C after up to 10,000 program/erase cycles	t _{D_ret}	15	100	—	years

1. Minimum times are based on maximum f_{NVMOP} and maximum f_{NVMBUS}
2. Typical times are based on typical f_{NVMOP} and maximum f_{NVMBUS}
3. Maximum times are based on typical f_{NVMOP} and typical f_{NVMBUS} plus aging
4. t_{cyc} = 1 / f_{NVMBUS}

Program and erase operations do not require any special power sources other than the normal V_{DDX} supply. For more detailed information about program/erase operations, see the Flash Memory Module section in the reference manual.

3.3 Analog

3.3.1 ADC characteristics

Table 11. 5 V 12-bit ADC operating conditions

Characteristic	Conditions	Symb	Min	Typ ¹	Max	Unit	Comment
Input voltage		V _{ADIN}	V _{REFL}	—	V _{REFH}	V	
Input capacitance		C _{ADIN}	—	4.5	5.5	pF	
Input resistance		R _{ADIN}	—	3	5	kΩ	—

Table continues on the next page...

Table 11. 5 V 12-bit ADC operating conditions (continued)

Characteristic	Conditions	Symb	Min	Typ ¹	Max	Unit	Comment
Analog source resistance	12-bit mode	R_{AS}	—	—	2	k Ω	External to MCU
	• $f_{ADCK} > 4$ MHz		—	—	5		
	• $f_{ADCK} < 4$ MHz		—	—	5		
	10-bit mode		—	—	5		
	• $f_{ADCK} > 4$ MHz		—	—	10		
	• $f_{ADCK} < 4$ MHz		—	—	10		
	8-bit mode (all valid f_{ADCK})		—	—	10		
ADC conversion clock frequency	High speed (ADLPC=0)	f_{ADCK}	0.4	—	8.0	MHz	—
	Low power (ADLPC=1)		0.4	—	4.0		

1. Typical values assume $V_{DDA} = 5.0$ V, Temp = 25°C, $f_{ADCK}=1.0$ MHz unless otherwise stated. Typical values are for reference only and are not tested in production.

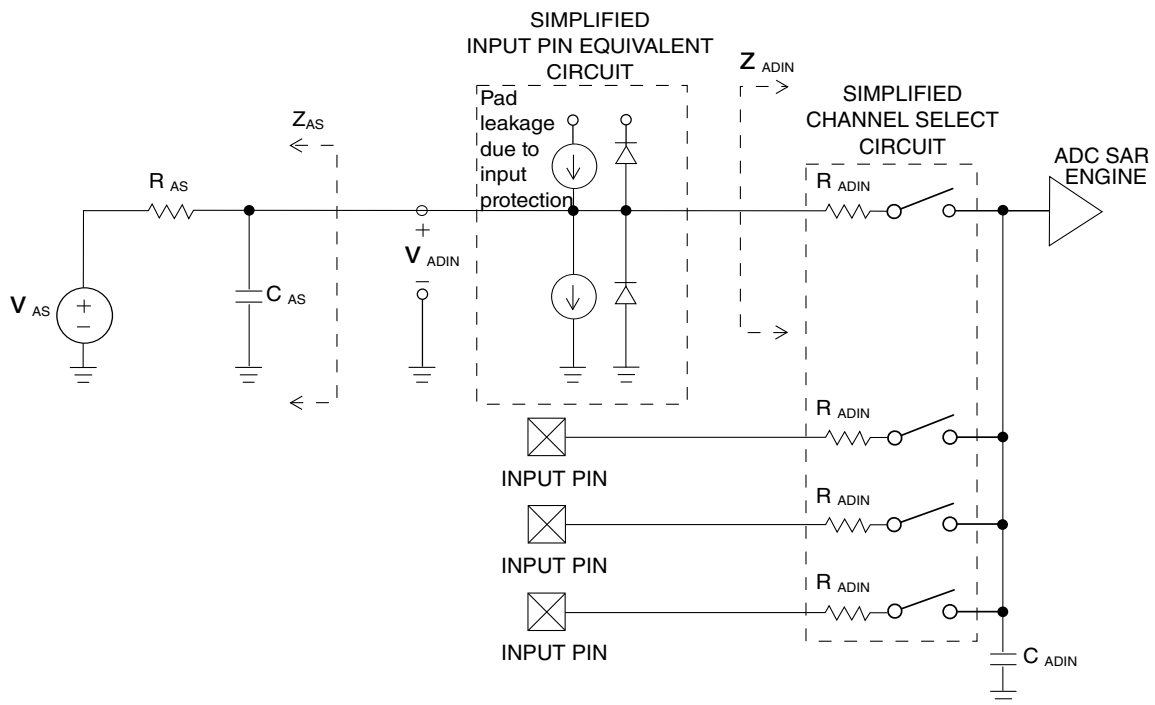

Figure 11. ADC input impedance equivalency diagram

Table 12. 12-bit ADC Characteristics ($V_{REFH} = V_{DDA}$, $V_{REFL} = V_{SSA}$)

Characteristic	Conditions	C	Symb	Min	Typ ¹	Max	Unit
Supply current ADLPC = 1 ADLSMP = 1		T	I_{DDA}	—	133	—	μ A

Table continues on the next page...

Table 12. 12-bit ADC Characteristics ($V_{REFH} = V_{DDA}$, $V_{REFL} = V_{SSA}$) (continued)

Characteristic	Conditions	C	Symb	Min	Typ ¹	Max	Unit
ADCO = 1							
Supply current ADLPC = 1 ADLSMP = 0 ADCO = 1		T	I_{DDA}	—	218	—	μA
Supply current ADLPC = 0 ADLSMP = 1 ADCO = 1		T	I_{DDA}	—	327	—	μA
Supply current ADLPC = 0 ADLSMP = 0 ADCO = 1		T	I_{DDAD}	—	582	990	μA
Supply current	Stop, reset, module off	T	I_{DDA}	—	0.011	1	μA
ADC asynchronous clock source	High speed (ADLPC = 0)	T	f_{ADACK}	2	3.3	5	MHz
	Low power (ADLPC = 1)			1.25	2	3.3	
Conversion time (including sample time)	Short sample (ADLSMP = 0)	T	t_{ADC}	—	20	—	ADCK cycles
	Long sample (ADLSMP = 1)			—	40	—	
Sample time	Short sample (ADLSMP = 0)	T	t_{ADS}	—	3.5	—	ADCK cycles
	Long sample (ADLSMP = 1)			—	23.5	—	
Total unadjusted Error ^{2,3}	12-bit mode	T	E_{TUE}	—	± 5.5	—	LSB ⁴
	10-bit mode	T		—	± 1.7	± 2.0	
	8-bit mode	T		—	± 0.9	± 1.0	
Differential Non-Linearity ³	12-bit mode	T	DNL	—	1.4	—	LSB ⁴
	10-bit mode ⁵	P		—	0.5	—	
	8-bit mode ⁵	T		—	0.15	—	
Integral Non-Linearity ³	12-bit mode	T	INL	—	1.4	—	LSB ⁴
	10-bit mode	T		—	0.5	—	
	8-bit mode	T		—	0.15	—	
Zero-scale error ⁶	12-bit mode	C	E_{ZS}	—	± 2.0	—	LSB ⁴
	10-bit mode	T		—	± 0.25	± 1.0	
	8-bit mode	T		—	± 0.65	± 1.0	
Full-scale error ⁷	12-bit mode	T	E_{FS}	—	± 2.5	—	LSB ⁴

Table continues on the next page...

Table 12. 12-bit ADC Characteristics ($V_{REFH} = V_{DDA}$, $V_{REFL} = V_{SSA}$) (continued)

Characteristic	Conditions	C	Symb	Min	Typ ¹	Max	Unit
	10-bit mode	T		—	±0.5	±1.0	
	8-bit mode	T		—	±0.5	±1.0	
Quantization error	≤12 bit modes	D	E_Q	—	—	±0.5	LSB ⁴
Input leakage error ⁸	all modes	D	E_{IL}	$I_{in} * R_{AS}$			mV
Temp sensor slope	-40°C– 25°C	D	m	—	3.266	—	mV/°C
	25°C– 125°C			—	3.638	—	
Temp sensor voltage	25°C	D	V_{TEMP25}	—	1.36	—	V

1. Typical values assume $V_{DDX} = 5.0$ V, $V_{DD} \geq 5.3$ V, Temp = 25°C, $f_{ADCK} = 1.0$ MHz unless otherwise stated. Typical values are for reference only and are not tested in production.
2. Includes quantization.
3. To get better ADC performance: For the application case of $V_{DD} < 5.3$ V, suggest to select V_{REFH} as ADC reference. For the application case $V_{DD} \geq 5.3$ V, suggest to select V_{DDX} as ADC reference.
4. $1 \text{ LSB} = (V_{REFH} - V_{REFL})/2^N$
5. Monotonicity and no-missing-codes guaranteed in 10-bit and 8-bit modes
6. $V_{ADIN} = V_{SSA}$
7. $V_{ADIN} = V_{DDA}$
8. I_{in} = leakage current (refer to DC characteristics)

3.3.2 CMP and 6-bit DAC electrical specifications

Table 13. Comparator and 6-bit DAC electrical specifications

Symbol	Description		Min.	Typ.	Max.	Unit
V_{DDX}	Supply voltage		4.20	5.0	5.25	V
I_{DDHS}	Supply current, high-speed mode (EN=1, PMODE=1)		—	100	—	μA
$I_{DDL S}$	Supply current, low-speed mode (EN=1, PMODE=0)		—	18	20	μA
V_{AIN}	Analog input voltage		$V_{SS} - 0.3$	—	V_{DDX}	V
V_{AIO}	Analog input offset voltage		—	—	40	mV
V_H	Analog comparator hysteresis	CR0[HYSTCTR] = 0	—	15	20	mV
		CR0[HYSTCTR] = 1	—	20	30	mV
V_{CMPOH}	Output high		$V_{DDX} - 0.5$	—	—	V
V_{CMPOI}	Output low		—	—	0.5	V
I_{ALKG}	Analog input leakage current		—	—	20	nA
t_{DHS}	Propagation delay, high-speed mode (EN=1, PMODE=1)	200 mV delta voltage	—	70	120	ns
		100 mV delta voltage	—	100	150	ns
		50 mV delta voltage	—	200	250	ns
t_{DLS}	Propagation delay, low-speed mode (EN=1, PMODE=0)	200 mV delta voltage	—	400	600	ns
		100 mV delta voltage	—	600	800	ns

Table continues on the next page...

Table 13. Comparator and 6-bit DAC electrical specifications (continued)

Symbol	Description	Min.	Typ.	Max.	Unit
	50 mV delta voltage	—	1000	1500	ns
	Analog comparator initialization delay ¹	—	—	40	μs
I _{DAC6b}	6-bit DAC current adder (enabled)	—	7	—	μA
INL	6-bit DAC integral non-linearity	-0.5	—	0.5	LSB ²
DNL	6-bit DAC differential non-linearity	-0.3	—	0.3	LSB

1. Comparator initialization delay is defined as the time between software writes to change control inputs (Writes to DACEN, VRSEL, PSEL, MSEL, VOSEL) and the comparator output settling to a stable level.
2. 1 LSB = $V_{reference}/64$

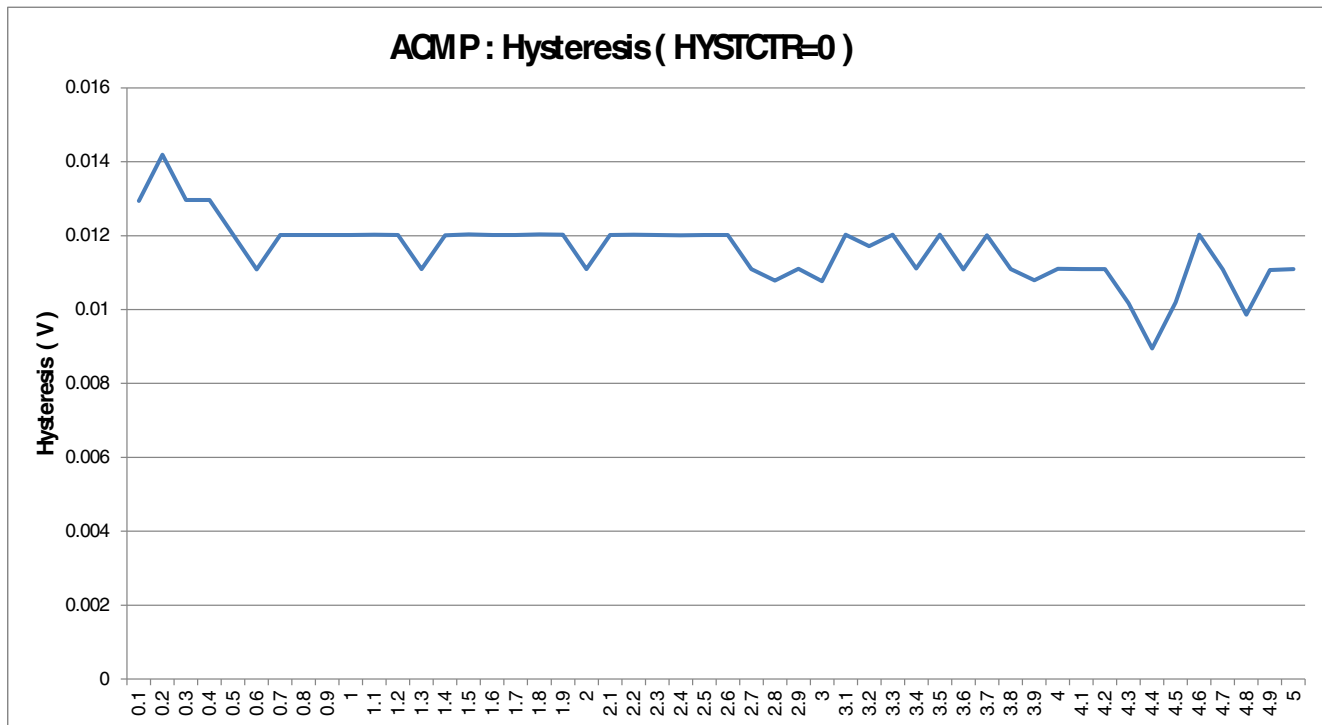

Figure 12. Typical hysteresis vs. Vin level ($V_{DDX} = 5.0 \text{ V}$, $\text{PMODE} = 0$)

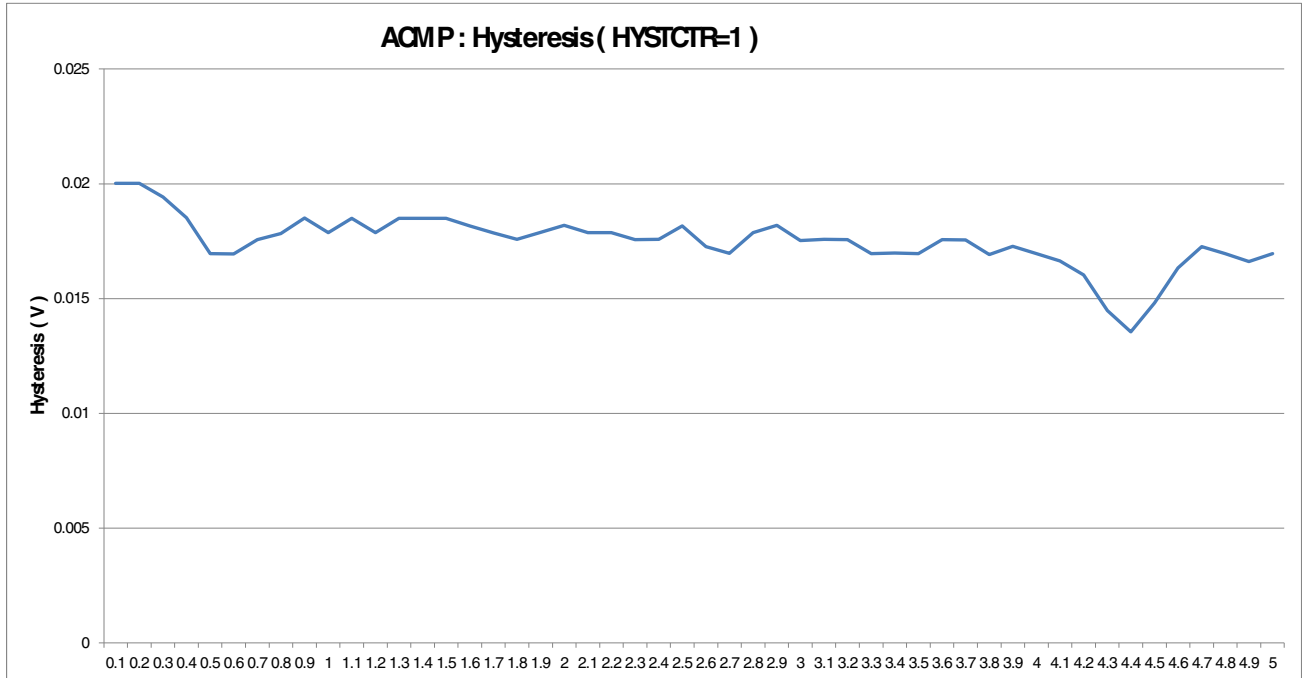

Figure 13. Typical hysteresis vs. Vin level ($V_{DDX} = 5.0$ V, PMODE = 1)

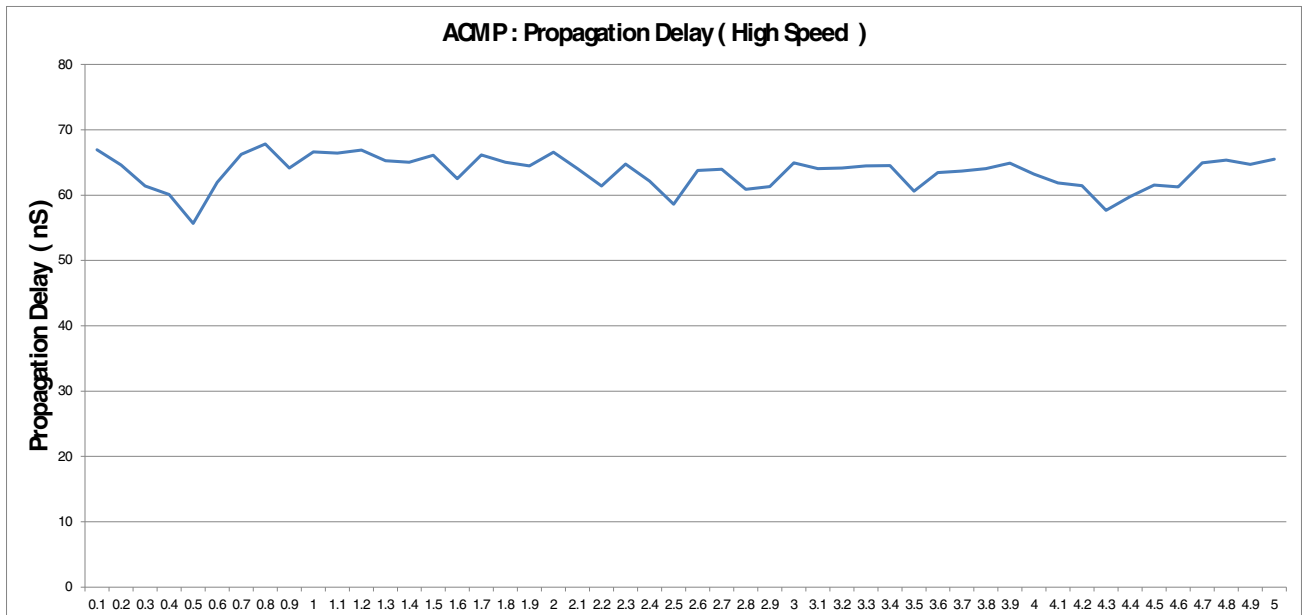

Figure 14. Typical propagation delay vs. Vin level ($V_{DDX} = 5.0$ V, high speed mode)

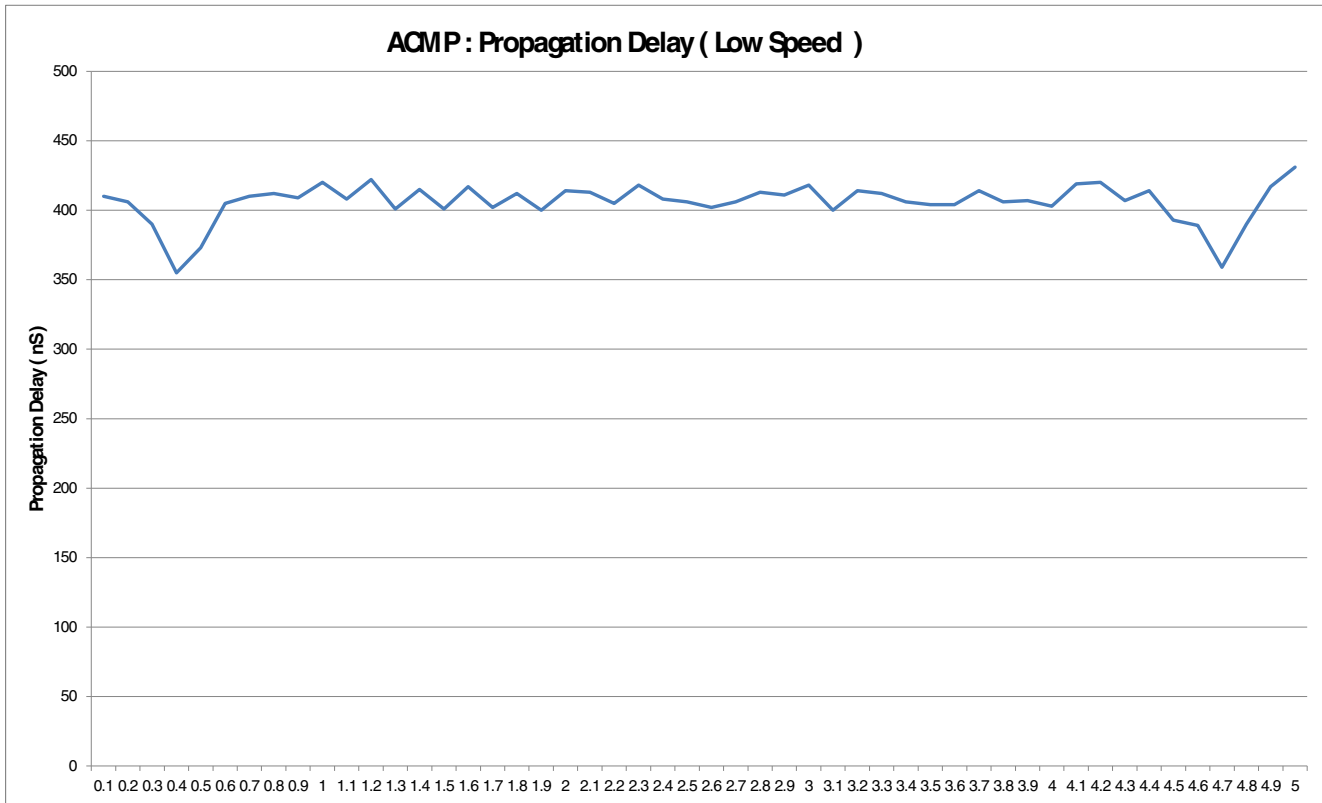

Figure 15. Typical propagation delay vs. Vin level (V_{DDX}=5.0 V, low speed mode)

3.3.3 GDU characteristics

Table 14. GDU electrical specifications

Symbol	Description	Min.	Typ.	Max.	Unit	Note
R	Internal resistor for voltage divider	—	17	—	kΩ	1
R1	PGA internal resistor 1	—	6.4x20	—	kΩ	2
R2	PGA internal resistor 2	—	6.4	—	kΩ	2
V _{shant}	Current shunt resistor Delta voltage for negative and positive current sensor function	-80	—	80	mV	2
V _{OH}	DC VOH for HS, V _{DDX} =5 V, V _{DD} =12 V	I _{Load} =5 mA	V _{DD} -570	V _{DD} -301	—	mV
		I _{Load} =10 mA	V _{DD} -580	V _{DD} -313	—	mV
		I _{Load} =15 mA	V _{DD} -590	V _{DD} -323	—	mV
		I _{Load} =20 mA	V _{DD} -600	V _{DD} -333	—	mV
	DC VOH for LS, V _{DDX} =5 V, V _{DD} =12 V	I _{Load} =5 mA	V _{DDX} -570	V _{DDX} -360	—	mV
		I _{Load} =15 mA	V _{DDX} -580	V _{DDX} -400	—	mV
I _{Load} =20 mA		V _{DDX} -600	V _{DDX} -420	—	mV	
V _{OL}	DC VOL for HS, V _{DDX} =5 V, V _{DD} =12 V	I _{Load} =5 mA	—	295	570	mV
		I _{Load} =10 mA	—	305	580	mV

Table continues on the next page...

Table 14. GDU electrical specifications (continued)

Symbol	Description	Min.	Typ.	Max.	Unit	Note
		$I_{Load}=15\text{ mA}$	—	317	590	mV
		$I_{Load}=20\text{ mA}$	—	330	600	mV
	DC VOL for LS, $V_{DDX}=5\text{ V}$, $V_{DD}=12\text{ V}$	$I_{Load}=5\text{ mA}$	—	290	570	mV
		$I_{Load}=15\text{ mA}$	—	320	580	mV
		$I_{Load}=20\text{ mA}$	—	335	600	mV
I_{OH}	$V_{DDX}=5\text{ V}$, $V_{DD}=12\text{ V}$, $V_{Out}=V_{DD}-0.4\text{V}$	—	7.45	—	mA	
	$V_{DDX}=5\text{ V}$, $V_{DD}=12\text{ V}$, $V_{Out}=V_{DDX}-0.4\text{V}$	—	7.45	—	mA	
I_{OL}	$V_{DDX}=5\text{ V}$, $V_{DD}=12\text{ V}$ $V_{Out}=V_{clamp}+0.4\text{V}$	—	6.45	—	mA	
	$V_{DDX}=5\text{ V}$, $V_{DD}=12\text{ V}$ $V_{Out}=V_{SS}+0.4\text{V}$	—	6.45	—	mA	
R_{pullup}	Pullup resistor of HS predriver, gate to source of PFET	192	226	260	k Ω	
$R_{pulldown}$	Pulldown resistor of LS predriver, gate to source of NFET	30	40	50	k Ω	
V_{clamp1}	$V_{DD}-V_{o_clamp}$ in regulation mode with $5.5\text{ V} \leq V_{DD} \leq 18\text{ V}$, loading current is less than 10 mA	4.5	5	5.5	V	
V_{clamp2}	$V_{DD}-V_{o_clamp}$ in open loop mode with $4.5\text{ V} \leq V_{DD} < 5.5\text{ V}$, loading current is less than 10 mA	4.0	—	5	V	
I_{Load}	The sink current capability	—	—	10	mA	
	Line regulation, ΔV_{clamp} over ΔV_{DD}	$4.5\text{ V} \leq V_{DD} < 5.5\text{ V}^3$	—	1000	—	mV/V
		$5.5\text{ V} \leq V_{DD} \leq 18\text{ V}$	—	10	—	mV/V
	Load regulation, ΔV_{clamp} over ΔI_{Load}	$4.5\text{ V} \leq V_{DD} < 5.5\text{ V}^3$	—	25	—	Ω
		$5.5\text{ V} \leq V_{DD} \leq 18\text{ V}$	—	1	—	Ω
OVP_22V_a	22V over-voltage asserting threshold	21	22	23	V	
OVP_22V_d	22V over-voltage de-asserting threshold	19	20	21	V	
OVP_22V_h	22V over-voltage hysteresis	1.9	2	2.1	V	
OVP_24V_a	24V over-voltage asserting threshold	23	24	25	V	
OVP_24V_d	24V over-voltage de-asserting threshold	22	23	24	V	
OVP_24V_h	24V over-voltage hysteresis	0.9	1	1.1	V	

- Customer need to add external resistor R_{ext1} for voltage divider. For example ,if $R_{ext1}=85\text{ k}\Omega$,1/6 voltage divider; if $R_{ext1}=105\text{ k}\Omega$,1/7 voltage divider.
- PGA gain is default to 20X. User can cascade one external series resistor (R_{ext2}) to reduce the PGA gain. To keep the current sensor PGA output without saturation distortion, the selected R_{ext2} must meet $PGA\text{ output}=V_{REF}+(R1/(R2+R_{ext2}))\times V_{shunt}$, $V_{REF}=0.5\times V_{DDX}$, see reference manual for the R1 and R2.
- This 5.5 V is a rough value, each part might has different value but around 5.5 V.

Table 15. GDU phase detector ACMP electrical specifications

Symbol	Description	Min.	Typ.	Max.	Unit
V _{DDX}	Supply voltage	4.20	5.0	5.25	V
I _{DDHS}	Supply current, high-speed mode (EN=1, PMODE=1)	—	100	—	μA
I _{DDL}	Supply current, low-speed mode (EN=1, PMODE=0)	—	18	20	μA
V _{AIN}	Analog input voltage	0	—	V _{DDX} -1	V
V _{AIO}	Analog input offset voltage	—	—	40	mV
V _H	Analog comparator hysteresis	—	15	20	mV
		—	20	30	mV
V _{CMPOh}	Output high	V _{DDX} - 0.5	—	—	V
V _{CMPOl}	Output low	—	—	0.5	V
I _{ALKG}	Analog input leakage current	—	—	20	nA
t _{DHS}	Propagation delay, high-speed mode (EN=1, PMODE=1), 200mV delta voltage	—	70	120	ns
t _{DLS}	Propagation delay, low-speed mode (EN=1, PMODE=0), 200mV delta voltage	—	400	600	ns
	Analog comparator initialization delay ¹	—	—	40	μs

1. Comparator initialization delay is defined as the time between software writes to change control inputs (Writes to DACEN, VRSEL, PSEL, MSEL, VOSEL) and the comparator output settling to a stable level.

Table 16. GDU over current protect ACMP electrical specifications

Symbol	Description	Min.	Typ.	Max.	Unit
V _{DDX}	Supply voltage	4.20	5.0	5.25	V
I _{DDHS}	Supply current, high-speed mode (EN=1, PMODE=1)	—	100	—	μA
I _{DDL}	Supply current, low-speed mode (EN=1, PMODE=0)	—	18	20	μA
V _{AIN}	Analog input voltage	V _{SS} - 0.3	—	V _{DDX}	V
V _{AIO}	Analog input offset voltage	—	20	40	mV
V _H	Analog comparator hysteresis	—	15	20	mV
		—	20	30	mV
V _{CMPOh}	Output high	V _{DDX} - 0.5	—	—	V
V _{CMPOl}	Output low	—	—	0.5	V
I _{ALKG}	Analog input leakage current	—	—	20	nA
t _{DHS}	Propagation delay, high-speed mode (EN=1, PMODE=1), 200mV delta voltage	—	70	120	ns
t _{DLS}	Propagation delay, low-speed mode (EN=1, PMODE=0), 200mV delta voltage ¹	—	400	600	ns
	Analog comparator initialization delay ²	—	—	40	μs
INL	6-bit DAC integral non-linearity	-0.5	—	0.5	LSB ³

Table continues on the next page...

Table 16. GDU over current protect ACMP electrical specifications (continued)

Symbol	Description	Min.	Typ.	Max.	Unit
DNL	6-bit DAC differential non-linearity	-0.3	—	0.3	LSB

1. This ACMP is used for over-current protection, customer can use low power mode to avoid sparkles. Digital filter can produce max of 12.8 μ s filter window.
2. Comparator initialization delay is defined as the time between software writes to change control inputs (Writes to DACEN, VRSEL, PSEL, MSEL, VOSEL) and the comparator output settling to a stable level.
3. 1 LSB = $V_{reference}/64$

3.4 Communication interfaces

3.4.1 Inter-Integrated Circuit Interface (I2C) timing

Table 17. I2C timing

Characteristic	Symbol	Standard Mode		Fast Mode		Unit
		Minimum	Maximum	Minimum	Maximum	
SCL Clock Frequency	f_{SCL}	0	100	0	400 ¹	kHz
Hold time (repeated) START condition. After this period, the first clock pulse is generated.	$t_{HD}; STA$	4	—	0.6	—	μ s
LOW period of the SCL clock	t_{LOW}	4.7	—	1.3	—	μ s
HIGH period of the SCL clock	t_{HIGH}	4	—	0.6	—	μ s
Set-up time for a repeated START condition	$t_{SU}; STA$	4.7	—	0.6	—	μ s
Data hold time for I ² C bus devices	$t_{HD}; DAT$	0 ²	3.45 ³	0 ⁴	0.9 ²	μ s
Data set-up time	$t_{SU}; DAT$	250 ⁵	—	100 ^{3,6}	—	ns
Rise time of SDA and SCL signals	t_r	—	1000	$20 + 0.1C_b$ ⁷	300	ns
Fall time of SDA and SCL signals	t_f	—	300	$20 + 0.1C_b$ ⁶	300	ns
Set-up time for STOP condition	$t_{SU}; STO$	4	—	0.6	—	μ s
Bus free time between STOP and START condition	t_{BUF}	4.7	—	1.3	—	μ s
Pulse width of spikes that must be suppressed by the input filter	t_{SP}	N/A	N/A	0	50	ns

1. The maximum SCL Clock Frequency in Fast mode with maximum bus loading can only be achieved when using the High drive pins (see [DC characteristics](#)) or when using the Normal drive pins and $V_{DDX} \geq 2.7$ V
2. The master mode I²C deasserts ACK of an address byte simultaneously with the falling edge of SCL. If no slaves acknowledge this address byte, then a negative hold time can result, depending on the edge rates of the SDA and SCL lines.
3. The maximum $t_{HD}; DAT$ must be met only if the device does not stretch the LOW period (t_{LOW}) of the SCL signal.
4. Input signal Slew = 10 ns and Output Load = 50 pF
5. Set-up time in slave-transmitter mode is 1 I²C clock period, if the TX FIFO is empty.

Dimensions

6. A Fast mode I²C bus device can be used in a Standard mode I²C bus system, but the requirement $t_{SU; DAT} \geq 250$ ns must then be met. This is automatically the case if the device does not stretch the LOW period of the SCL signal. If such a device does stretch the LOW period of the SCL signal, then it must output the next data bit to the SDA line $t_{rmax} + t_{SU; DAT} = 1000 + 250 = 1250$ ns (according to the Standard mode I²C bus specification) before the SCL line is released.
7. C_b = total capacitance of the one bus line in pF.

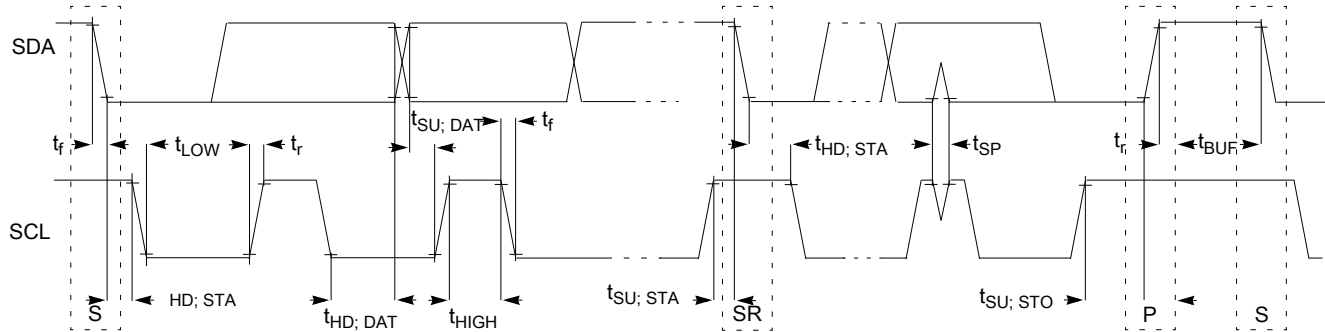

Figure 16. Timing definition for fast and standard mode devices on the I²C bus

4 Dimensions

4.1 Obtaining package dimensions

Package dimensions are provided in package drawings.

To find a package drawing, go to nxp.com and perform a keyword search for the drawing's document number:

If you want the drawing for this package	Then use this document number
24-pin QFN	98ASA00602D

5 Pinout

5.1 Signal multiplexing and pin assignments

The following table shows the signals available on each pin and the locations of these pins on the devices supported by this document. The Port Control Module is responsible for selecting which ALT functionality is available on each pin.

24 QFN	Pin Name	Default/ALT0	ALT1	ALT2	ALT3
1	PTB5	PWM_WL			PTB5

24 QFN	Pin Name	Default/ALT0	ALT1	ALT2	ALT3
2	PWM_UH	PWM_UH			
3	PWM_VH	PWM_VH			
4	PWM_WH	PWM_WH			
5	VCLAMP	VCLAMP			
6	VDD	VDD			
7	VDDX	VDDX			
8	VSS	VSS			
9	PTB6/ RESET_b	RESET_b		TCLK	PTB6
10	PTC0	CMP_REF/ VREFH	PWM_FAULT0	CLK_IN	PTC0
11	PTB7/ BKGD/ MS	BKGD/ MS		CLKOUT	PTB7
12	PTA7	PWT1	TX	XB_OUT1	PTA7/ KBI7
13	PTA6	PWT0	RX	XB_IN1	PTA6/ KBI6
14	PTA5	TX	SDA	XB_OUT0	PTA5/ KBI5
15	PTA4	RX	SCL	XB_IN0	PTA4/ KBI4
16	PTA3	AMP1_M/ ADC1AD1	CLKOUT	XB_OUT1	PTA3/ KBI3
17	PTA2	AMP1_P/ CMP2/ ADC1AD0	XB_IN1	XB_OUT0	PTA2/ KBI2
18	PTA1	AMP0_M/ CMP1/ ADC0AD1	XB_OUT0	XB_IN1	PTA1/ KBI1
19	PTA0	AMP0_P/ CMP0/ ADC0AD0	CLK_IN	XB_IN0	PTA0/ KBI0
20	PTB0	GDU_CMP0/ ADC0AD2/ ADC1AD2			PTB0
21	PTB1	GDU_CMP1/ ADC0AD3/ ADC1AD3			PTB1
22	PTB2	GDU_CMP2/ ADC0AD4/ ADC1AD4			PTB2
23	PTB3	PWM_UL			PTB3
24	PTB4	PWM_VL			PTB4

5.2 Pinout

The following figures show the pinout diagrams for the devices supported by this document. Many signals may be multiplexed onto a single pin. To determine what signals can be used on which pin, see [Signal multiplexing and pin assignments](#).

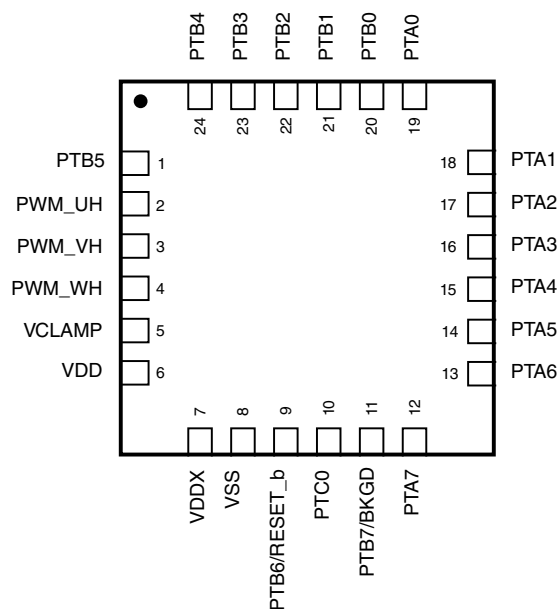

Figure 17. 24-pin QFN pinout diagram

6 Part identification

6.1 Description

Part numbers for the chip have fields that identify the specific part. You can use the values of these fields to determine the specific part you have received.

6.2 Format

Part numbers for this device have the following format:

MC 9 S08 SU AA B CC

6.3 Fields

This table lists the possible values for each field in the part number :

Field	Description	Values
MC	Qualification status	<ul style="list-style-type: none"> MC = fully qualified, general market flow
9	Memory	<ul style="list-style-type: none"> 9 = flash based
S08	Core	<ul style="list-style-type: none"> S08 = 8-bit CPU
SU	Device family	<ul style="list-style-type: none"> SU
AA	Approximate flash size in KB	<ul style="list-style-type: none"> 8 = 8 KB 16 = 16 KB
B	Temperature range (°C)	<ul style="list-style-type: none"> V = -40 to 105
CC	Package designator	<ul style="list-style-type: none"> FK = 24-pin QFN

6.4 Example

This is an example part number:

MC9S08SU16VFK

7 Terminology and guidelines

7.1 Definition: Operating requirement

An *operating requirement* is a specified value or range of values for a technical characteristic that you must guarantee during operation to avoid incorrect operation and possibly decreasing the useful life of the chip.

7.1.1 Example

This is an example of an operating requirement:

Symbol	Description	Min.	Max.	Unit
V _{DD}	1.0 V core supply voltage	0.9	1.1	V

7.2 Definition: Operating behavior

Unless otherwise specified, an *operating behavior* is a specified value or range of values for a technical characteristic that are guaranteed during operation if you meet the operating requirements and any other specified conditions.

7.2.1 Example

This is an example of an operating behavior:

Symbol	Description	Min.	Max.	Unit
I _{WP}	Digital I/O weak pullup/pulldown current	10	130	μA

7.3 Definition: Attribute

An *attribute* is a specified value or range of values for a technical characteristic that are guaranteed, regardless of whether you meet the operating requirements.

7.3.1 Example

This is an example of an attribute:

Symbol	Description	Min.	Max.	Unit
CIN_D	Input capacitance: digital pins	—	7	pF

7.4 Definition: Rating

A *rating* is a minimum or maximum value of a technical characteristic that, if exceeded, may cause permanent chip failure:

- *Operating ratings* apply during operation of the chip.
- *Handling ratings* apply when the chip is not powered.

7.4.1 Example

This is an example of an operating rating:

Symbol	Description	Min.	Max.	Unit
V _{DD}	1.0 V core supply voltage	-0.3	1.2	V

7.5 Result of exceeding a rating

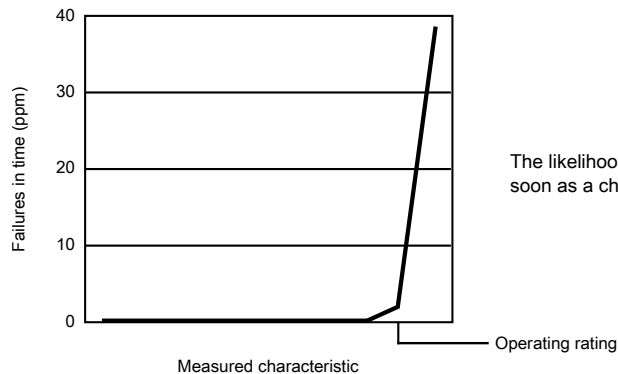

7.6 Relationship between ratings and operating requirements

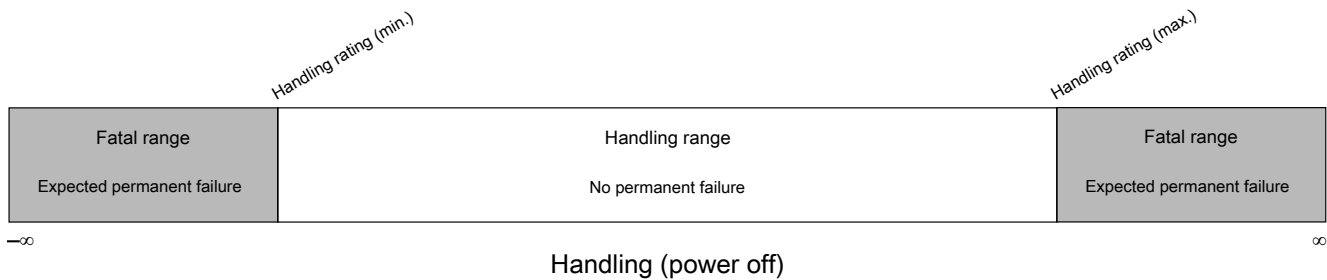
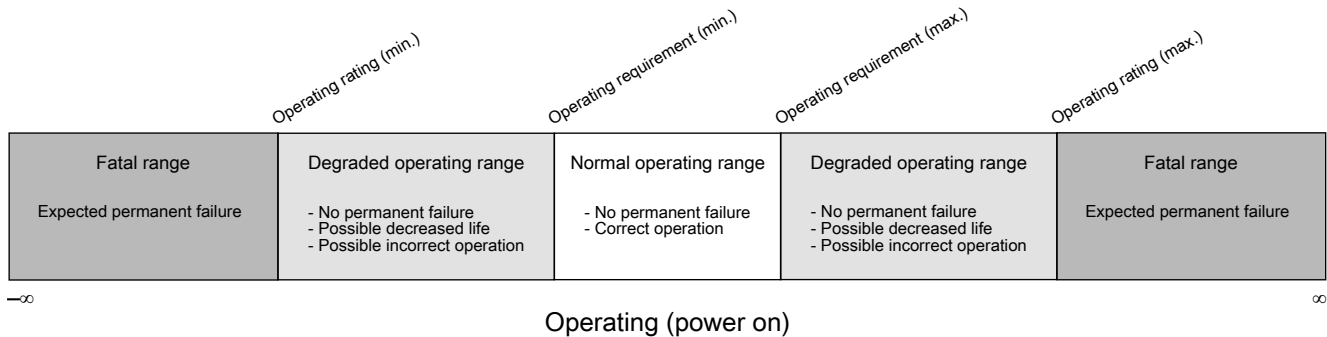

7.7 Guidelines for ratings and operating requirements

Follow these guidelines for ratings and operating requirements:

- Never exceed any of the chip’s ratings.
- During normal operation, don’t exceed any of the chip’s operating requirements.
- If you must exceed an operating requirement at times other than during normal operation (for example, during power sequencing), limit the duration as much as possible.

7.8 Definition: Typical value

A *typical value* is a specified value for a technical characteristic that:

- Lies within the range of values specified by the operating behavior
- Given the typical manufacturing process, is representative of that characteristic during operation when you meet the typical-value conditions or other specified conditions

Typical values are provided as design guidelines and are neither tested nor guaranteed.

7.8.1 Example 1

This is an example of an operating behavior that includes a typical value:

Symbol	Description	Min.	Typ.	Max.	Unit
I_{WP}	Digital I/O weak pullup/pulldown current	10	70	130	μA

7.8.2 Example 2

This is an example of a chart that shows typical values for various voltage and temperature conditions:

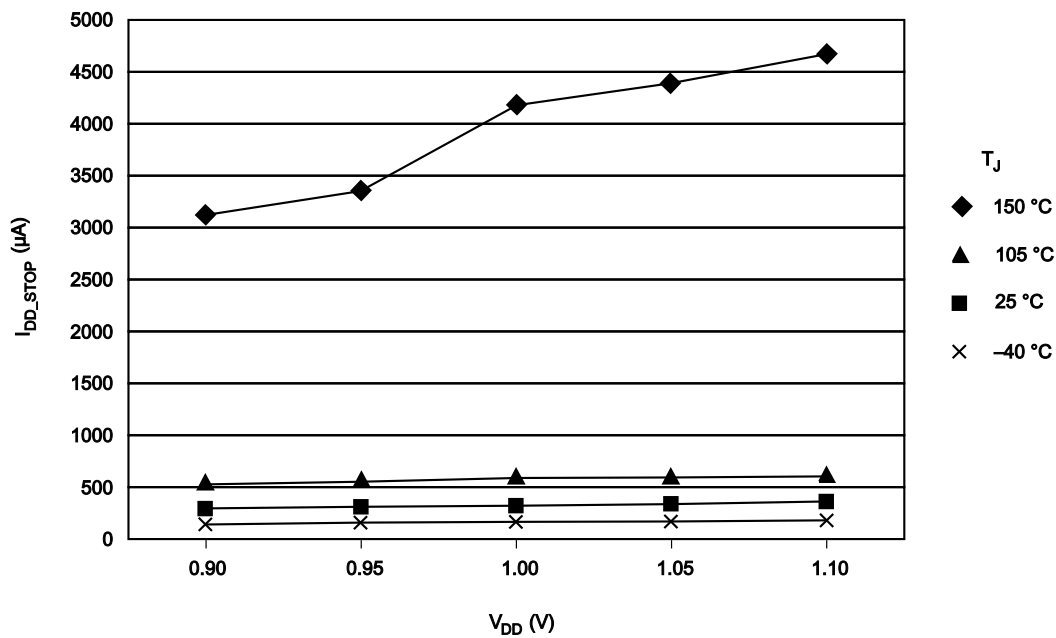

7.9 Typical value conditions

Typical values assume you meet the following conditions (or other conditions as specified):

Table 18. Typical value conditions

Symbol	Description	Value	Unit
T_A	Ambient temperature	25	°C
V_{DD}	3.3 V supply voltage	3.3	V

7.10 Parameter Classification

The electrical parameters shown in this supplement are guaranteed by various methods. To give the customer a better understanding, the following classification is used and the parameters are tagged accordingly in the tables where appropriate:

Table 19. Parameter Classifications

P	Those parameters are guaranteed during production testing on each individual device.
C	Those parameters are achieved by the design characterization by measuring a statistically relevant sample size across process variations.
T	Those parameters are achieved by design characterization on a small sample size from typical devices under typical conditions unless otherwise noted. All values shown in the typical column are within this category.
D	Those parameters are derived mainly from simulations.

NOTE

The classification is shown in the column labeled “C” in the parameter tables where appropriate.

8 Revision history

The following table provides a revision history for this document.

Table 20. Revision history

Rev. No.	Date	Substantial Changes
1	09/2016	<ul style="list-style-type: none"> Initial public release.
2	11/2016	<ul style="list-style-type: none"> Added MC9S08SU8VFK part.

How to Reach Us:

Home Page:

nxp.com

Web Support:

nxp.com/support

Information in this document is provided solely to enable system and software implementers to use NXP products. There are no express or implied copyright licenses granted hereunder to design or fabricate any integrated circuits based on the information in this document. NXP reserves the right to make changes without further notice to any products herein.

NXP makes no warranty, representation, or guarantee regarding the suitability of its products for any particular purpose, nor does NXP assume any liability arising out of the application or use of any product or circuit, and specifically disclaims any and all liability, including without limitation consequential or incidental damages. "Typical" parameters that may be provided in NXP data sheets and/or specifications can and do vary in different applications, and actual performance may vary over time. All operating parameters, including "typicals," must be validated for each customer application by customer's technical experts. NXP does not convey any license under its patent rights nor the rights of others. NXP sells products pursuant to standard terms and conditions of sale, which can be found at the following address: nxp.com/SalesTermsandConditions.

NXP, the NXP logo, Freescale, and the Freescale logo are trademarks of NXP B.V. All other product or service names are the property of their respective owners. All rights reserved.

© 2016 NXP B.V.



X-ON Electronics

Largest Supplier of Electrical and Electronic Components

Click to view similar products for [8-bit Microcontrollers - MCU category](#):

Click to view products by [NXP manufacturer](#):

Other Similar products are found below :

[CY8C20524-12PVXIT](#) [MB95F012KPFT-G-SNE2](#) [MB95F013KPMC-G-SNE2](#) [MB95F263KPF-G-SNE2](#) [MB95F264KPFT-G-SNE2](#)
[MB95F398KPMC-G-SNE2](#) [MB95F478KPMC2-G-SNE2](#) [MB95F564KPF-G-SNE2](#) [MB95F636KWQN-G-SNE1](#) [MB95F696KPMC-G-SNE2](#)
[MB95F698KPMC2-G-SNE2](#) [MB95F698KPMC-G-SNE2](#) [MB95F818KPMC1-G-SNE2](#) [901015X](#) [CY8C3MFIDOCK-125](#) [403708R](#)
[MB95F354EPF-G-SNE2](#) [MB95F564KWQN-G-SNE1](#) [MB95F636KP-G-SH-SNE2](#) [MB95F694KPMC-G-SNE2](#) [MB95F778JPMC1-G-SNE2](#)
[MB95F818KPMC-G-SNE2](#) [LC87F0G08AUJA-AH](#) [CP8361BT](#) [CG8421AF](#) [MB95F202KPF-G-SNE2](#) [DF36014FPV](#) [5962-8768407MUA](#)
[MB95F318EPMC-G-SNE2](#) [MB94F601APMC1-GSE1](#) [MB95F656EPF-G-SNE2](#) [LC78615E-01US-H](#) [LC87F5WC8AVU-QIP-H](#)
[MB95F108AJSPMC-G-JNE1](#) [73S1210F-68M/F/PJ](#) [MB89F538-101PMC-GE1](#) [LC87F7DC8AVU-QIP-H](#) [MB95F876KPMC-G-SNE2](#)
[MB88386PMC-GS-BNDE1](#) [LC87FBK08AU-SSOP-H](#) [LC87F2C64AU-QFP-H](#) [MB95F636KNWQN-G-118-SNE1](#) [MB95F136NBSTPFV-GS-](#)
[N2E1](#) [LC87F5NC8AVU-QIP-E](#) [CY8C20324-12LQXIT](#) [LC87F76C8AU-TQFP-E](#) [CG8581AA](#) [LC87F2G08AU-SSOP-E](#) [CP8085AT](#)
[MB95F564KPF-G-UNE2](#)