



MC9S12DP256

Advance Information

December 1, 2000 — Revision 1.1



Freescale Semiconductor, Inc.

Freescale Semiconductor, Inc.

**For More Information On This Product,
Go to: www.freescale.com**



List of Sections

List of Sections	3
Table of Contents	5
General Description	13
Central Processing Unit (CPU)	19
Pinout and Signal Description	41
System Configuration	63
Registers	65
Operating Modes	91
Resource Mapping	107
Bus Control and Input/Output	123
Resets and Interrupts	141
Voltage Regulator (VREG)	159
Flash EEPROM 256K	165
EEPROM 4K	193
Port Integration Module	213

Clocks and Reset Generator (CRG)	257
Pulse Width Modulator (PWM)	297
Enhanced Capture Timer (ECT)	341
Serial Communications Interface (SCI)	389
Serial Peripheral Interface (SPI)	429
Inter-IC Bus (IIC)	463
MSCAN	491
Analog to Digital Converter	555
Byte Data Link Controller Module	603
Background Debug Module (BDM)	691
Breakpoint (BKP) Module	713
Revision History	727
Glossary	729
Literature Updates	745

Table of Contents

Freescale Semiconductor, Inc.

List of Sections

Table of Contents

General Description	Contents	13
	Introduction	13
	Features	14
	MC9S12DP256 112-Pin Block Diagram	16
	Ordering Information	17
Central Processing Unit (CPU)	Contents	19
	Introduction	19
	Programming Model	20
	Data Types	22
	Addressing Modes	23
	Indexed Addressing Modes	24
	Opcodes and Operands	25
	Instruction Set Summary	26
Pinout and Signal Description	Contents	41
	MC9S12DP256 Pin Assignments in 112-pin QFP	41
	Power Supply Pins	44
	Signal Descriptions	47
	Port Signals	58
System Configuration	Contents	63
	Introduction	63
	Modules Variabilities	63
	MCU Variabilities	64



Table of Contents

Freescale Semiconductor, Inc.

Registers	Contents	65
	Register Block	65
Operating Modes	Contents	91
	Introduction	91
	Operating Modes	91
	Background Debug Mode	102
	Security	103
Resource Mapping	Contents	107
	Introduction	107
	Internal Resource Mapping	107
	Flash EEPROM mapping through internal Memory Expansion ...	111
	Miscellaneous System Control Register	118
	Memory Maps	119
Bus Control and Input/Output	Contents	123
	Introduction	123
	Detecting Access Type from External Signals	123
	Stretched Bus Cycles	124
	PIPE Status Signals	125
	Registers	127
Resets and Interrupts	Contents	141
	Introduction	141
	Register Map	142
	Exception Priority	142
	Maskable interrupts	143
	Latching of Interrupts	144
	Register Descriptions	147
	Resets	151
	Effects of Reset	155
	Register Stacking	157
Voltage Regulator (VREG)	Contents	159
	Overview	159



	Features	159
	Block Diagram	160
	Functional Description	161
	External Pin Connection	161
	Reset Initialization	164
	Modes of Operation	164
Flash EEPROM 256K	Contents	165
	Glossary	165
	Overview	166
	Features	167
	Block Diagram	168
	Module Memory Map	169
	Functional Description	174
	Register Descriptions	177
	External Pin Descriptions	190
	Reset Initialization	190
	Modes of Operation	190
	Low Power Options	190
	Interrupt Operation	191
EEPROM 4K	Contents	193
	Glossary	193
	Overview	194
	Features	194
	Block Diagram	195
	Module Memory Map	195
	Functional Description	198
	Register Descriptions	201
	External Pin Descriptions	210
	Reset Initialization	210
	Modes of Operation	210
	Interrupt Operation	211
Port Integration Module	Contents	213
	Overview	213
	Block Diagram	215

Table of Contents

	External Pin Descriptions	216
	80 Pin QFP bond-out version	216
	Register Map	217
	Register Descriptions	222
	Reset Initialization	251
	Functional Description	251
	Low Power Options	255
	Interrupt Operation	256
Clocks and Reset Generator (CRG)	Contents	257
	Overview	257
	Features	258
	Block Diagram	259
	Register Map	260
	Functional Description	261
	Register Descriptions	279
	External Pin Descriptions	292
	Reset Initialization	294
	Interrupt Operation	294
	Low Power Options	296
Pulse Width Modulator (PWM)	Contents	297
	Overview	297
	Features	298
	Block Diagram	299
	External Pin Descriptions	299
	Register Map	300
	Register Descriptions	302
	Functional Description	324
	Reset Initialization	338
	Modes of Operation	339
	Low Power Options	340
	Interrupt Operation	340
Enhanced Capture Timer (ECT)	Contents	341
	Overview	341
	Features	342



Modes of Operation 342

Abbreviations 342

Block Diagram 344

Signal Descriptions 350

Module Memory Map 351

Register Quick Reference 354

Register Descriptions 356

Modes of Operation 383

Interrupts 386

Description of Interrupt Operation 387

Serial Communications Interface (SCI)

 Contents 389

 Overview 389

 Features 389

 Modes of Operation 390

 SCI Interface Diagram 392

 Block Diagram 392

 Signal Descriptions 393

 Module Memory Map 394

 Register Quick Reference 395

 Register Descriptions 396

 Functional Description 406

 Modes of Operation 424

 Interrupt Operation 425

Serial Peripheral Interface (SPI)

 Contents 429

 Overview 429

 Features 430

 Modes of Operation 430

 Block Diagram 431

 Signal Descriptions 432

 Module Memory Map 436

 Register Quick Reference 437

 Register Descriptions 438

 Functional Description 446

 Low Power Mode Options 457

 Errata 459



Table of Contents

	Reset	460
	Interrupts	460
Inter-IC Bus (IIC)	Contents	463
	Overview	463
	Features	464
	Modes of Operation	464
	Block Diagram	465
	Signal Descriptions	467
	Module Memory Map	468
	Register Quick Reference	469
	Register Descriptions	469
	I-Bus Protocol	478
	Interrupt Operation	483
	Modes of Operation	484
	Programming	485
MSCAN	Contents	491
	Overview	491
	Features	492
	Block Diagram	493
	External Pin Descriptions	494
	Register Map	496
	Functional Description	499
	Register Descriptions	512
	Modes of Operation	546
	Low Power Options	547
	Interrupt Operation	553
Analog to Digital Converter	Contents	555
	Overview	555
	Features	556
	Block Diagram	557
	Register Map	559
	Functional Description	561
	Register Descriptions	572
	External Pin Descriptions	595



	Reset Initialization	596
	Modes of Operation	597
	Sample Conversion	599
	General Purpose Input Ports	602
Byte Data Link Controller Module	Contents	603
	Overview	603
	Features	604
	Block Diagram	605
	Register Map	606
	Functional Description	607
	Register Descriptions	633
	External Pin Descriptions	653
	Reset Initialization/Basic Operation	653
	Transmitting A Message	658
	Receiving A Message	664
	Transmitting An In-Frame Response (IFR)	669
	Receiving An In-Frame Response (IFR)	681
	Special BDLC Operations	683
	Modes of Operation	684
	Interrupt Operation	689
	Low Power Options	689
Background Debug Module (BDM)	Contents	691
	Overview	691
	Interface Signals	692
	Registers	693
	Operation	698
	Modes of Operation	710
	Low-Power Options	711
	Interrupt Operation	711
Breakpoint (BKP) Module	Contents	713
	Overview	713
	Features	714
	Block Diagram	715
	External Pin Descriptions	716



Table of Contents

Register Descriptions 716

Functional Description 723

Breakpoint Operating Modes 724

Breakpoint Types 725

Modes of Operation 725

Low Power Options 726

Reset Initialization 726

Interrupt Operation 726

General Purpose I/O Ports 726

Revision History Changes from Rev 1.0 to Rev 1.1 727

Glossary

Literature Updates Literature Distribution Centers 745

 Customer Focus Center 746

 Microcontroller Division's Web Site 746

General Description

Contents

Introduction	13
Features	14
MC9S12DP256 112-Pin Block Diagram	16
Ordering Information	17

Introduction

The MC9S12DP256 microcontroller unit (MCU) is a 16-bit device composed of standard on-chip peripherals including a 16-bit central processing unit (STAR12 CPU), 256K bytes of Flash EEPROM, 12.0K bytes of RAM, 4.0K bytes of EEPROM, 2 asynchronous serial communications interfaces (SCI), three serial peripheral interfaces (SPI), an 8 channel IC/OC enhanced capture timer, two 8-channel, 10-bit analog-to-digital converters (ADC), an 8-channel pulse-width modulator (PWM), a digital Byte Data Link Controller (BDLC), 29 discrete digital I/O channels (Port A, Port B, Port K and Port E), 20 discrete digital I/O lines with interrupt and wakeup capability, five CAN 2.0 A, B software compatible modules (MSCAN12), and an Inter-IC Bus. System resource mapping, clock generation, interrupt control and bus interfacing are managed by the System Integration Module (SIM). The MC9S12DP256 has full 16-bit data paths throughout. However, the external bus can operate in an 8-bit narrow mode so single 8-bit wide memory can be interfaced for lower cost systems. The inclusion of a PLL circuit allows power consumption and performance to be adjusted to suit operational requirements.

NOTE: *The main body of this document refers to the 112-pin version of the device. Pins shown in bold on the block diagram and pinout are not available on the 80-pin version.*

Features

- 16-bit STAR12 CPU
 - Upward compatible with M68HC11 instruction set
 - Interrupt stacking and programmer's model identical to M68HC11
 - 20-bit ALU
 - Instruction pipe
 - Enhanced indexed addressing
- Multiplexed External Bus
- Memory
 - 256K byte Flash EEPROM
 - 4.0K byte EEPROM
 - 12.0K byte RAM
- Two 8 channel Analog-to-Digital Converters
 - 10-bit resolution
- Five 1M bit per second, CAN 2.0 A, B software compatible modules
 - Four receive and three transmit buffers
 - Flexible identifier filter programmable as 2 x 32 bit, 4 x 16 bit or 8 x 8 bit
 - Four separate interrupt channels for Rx, Tx, error and wake-up
 - Low-pass filter wake-up function
 - Loop-back for self test operation
 - Time-stamping capabilities for network synchronization
- 8 channel IC/OC Enhanced Capture Timer
- Byte Data Link Controller (BDLC)
- Inter-IC Bus (IIC)

- 8 PWM channels with programmable period and duty cycle
 - Standard 8-bit 8-channel or 16-bit 4-channel or any combination of 8/16 bit
 - Separate control for each pulse width and duty cycle
 - Left-aligned or center-aligned outputs
 - Programmable clock select logic with a wide range of frequencies
 - Fast emergency shutdown input
 - Usable as interrupt inputs
- Serial interfaces
 - Two asynchronous Serial Communications Interfaces (SCI)
 - Three synchronous Serial Peripheral Interfaces (SPI)
- SIM (System integration module)
 - CRG (low current oscillator, PLL, reset, clocks, COP watchdog, real time interrupt, clock monitor)
 - MEBI (Multiplexed External Bus Interface)
 - MMC (Module Mapping Control)
 - INT (Interrupt control)
 - BKP (Breakpoints)
 - BDM (Background Debug Mode)
- 112-Pin LQFP package or 80-Pin QFP package
 - 50 MHz CPU equivalent to 25MHz bus operation
 - 2.25 to 2.75V Digital Supply Voltage generated using an internal voltage regulator
 - 4.75V to 5.25V Analog and I/O Supply Voltage
- Technology: 0.25 micron CMOS

General Description

MC9S12DP256 112-Pin Block Diagram

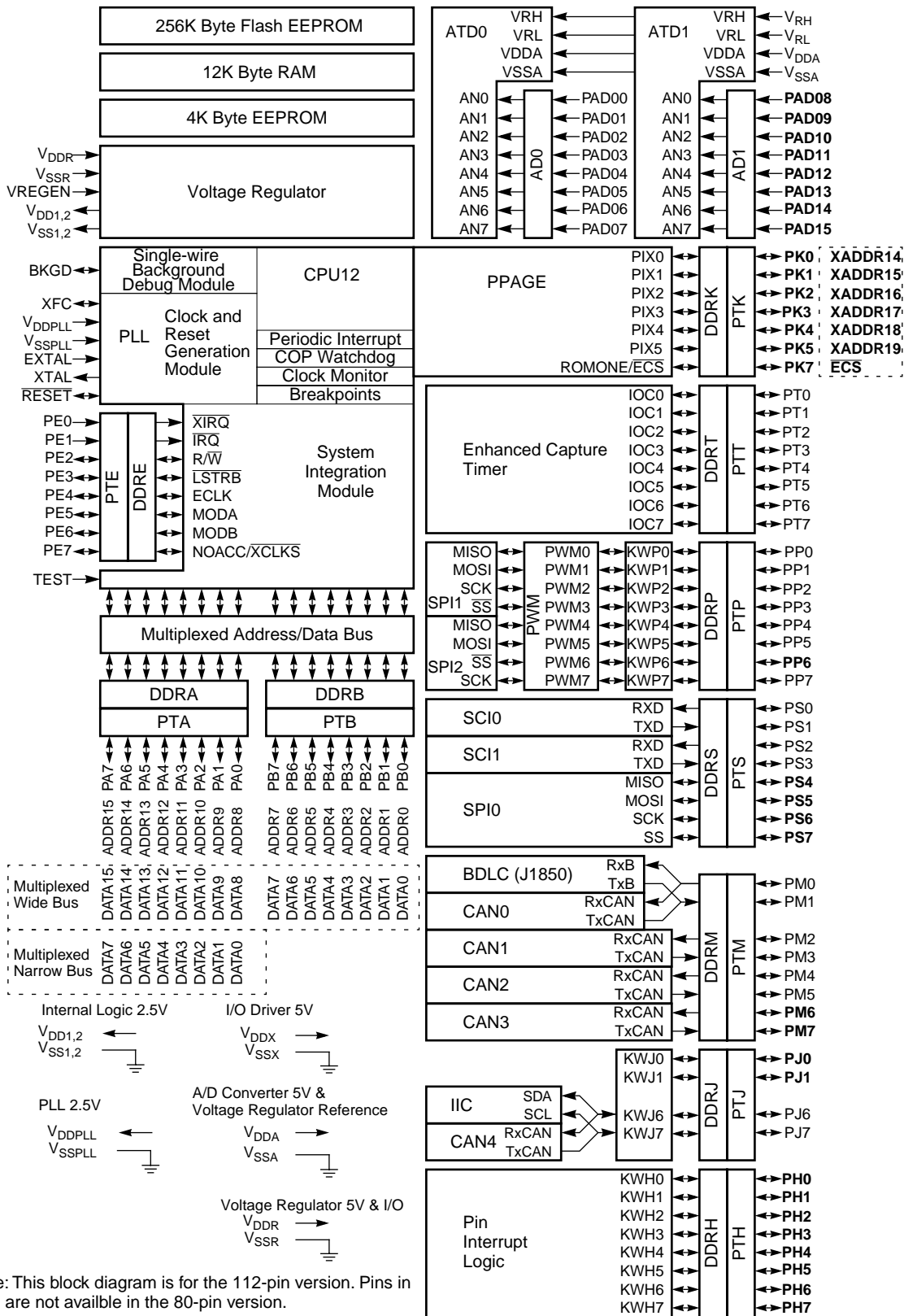

Note: This block diagram is for the 112-pin version. Pins in bold are not available in the 80-pin version.



Ordering Information

Table 1 MC9S12DP256 Device Ordering Information

Package	Temperature		Voltage	Frequency	Order Number
	Range	Designator			
112-Pin QFP	-40 to +125°C	C, V, M	5V	25MHz	TBD

Table 2 MC9S12DP256 Development Tools Ordering Information

Description	Details	Order Number
		TBD



Central Processing Unit (CPU)

Contents

Introduction	19
Programming Model	20
Data Types	22
Addressing Modes	23
Indexed Addressing Modes	24
Opcodes and Operands	25
Set Instruction Summary	24

Introduction

The STAR12 CPU is a high-speed, 16-bit processing unit. It has full 16-bit data paths and wider internal registers (up to 20 bits) for high-speed extended math instructions. The instruction set is a proper superset of the M68HC11 instruction set. The STAR12 CPU allows instructions with odd byte counts, including many single-byte instructions. This provides efficient use of ROM space. An instruction pipe buffers program information so the CPU always has immediate access to at least three bytes of machine code at the start of every instruction. The STAR12 CPU also offers an extensive set of indexed addressing capabilities.

Central Processing Unit (CPU)

Programming Model

STAR12 CPU registers are an integral part of the CPU and are not addressed as if they were memory locations.

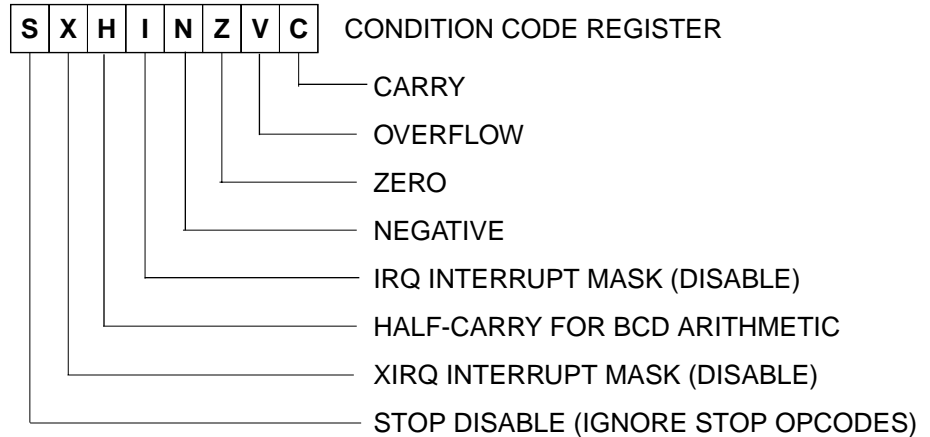
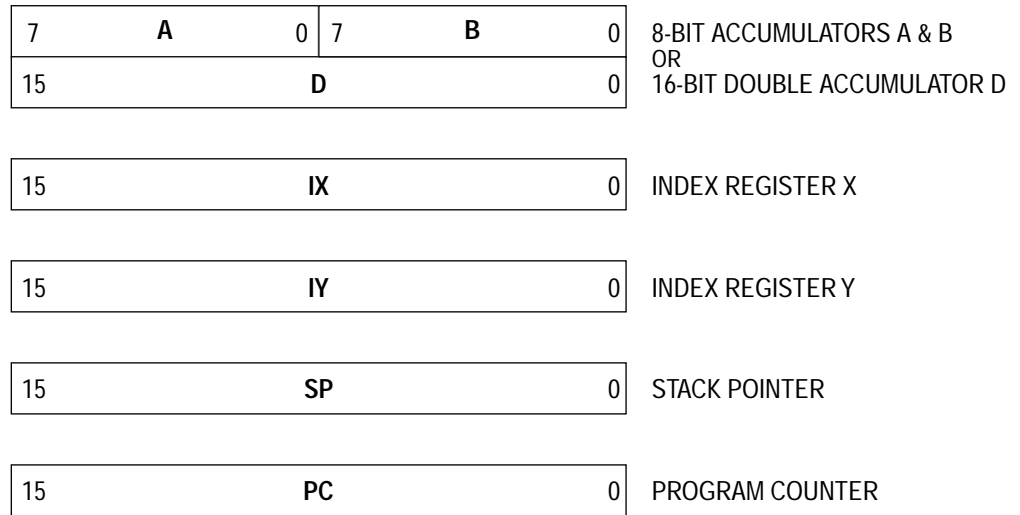
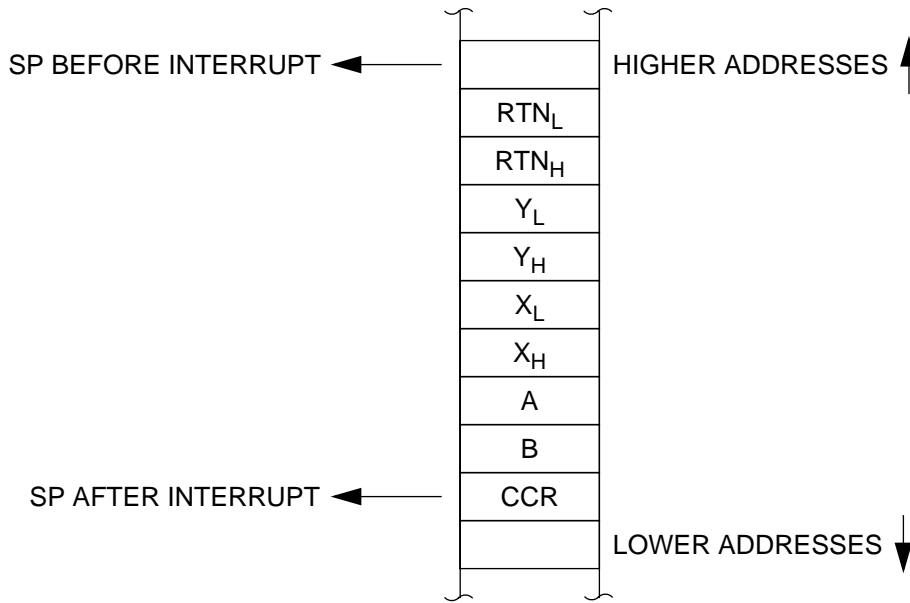

Figure 1 Programming Model

Accumulators A and B are general-purpose 8-bit accumulators used to hold operands and results of arithmetic calculations or data manipulations. Some instructions treat the combination of these two 8-bit accumulators as a 16-bit double accumulator (accumulator D).

Index registers X and Y are used for indexed addressing mode. In the indexed addressing mode, the contents of a 16-bit index register are added to 5-bit, 9-bit, or 16-bit constants or the content of an accumulator to form the effective address of the operand to be used in the instruction.

Stack and Memory Layout



STACK UPON ENTRY TO SERVICE ROUTINE
IF SP WAS ODD BEFORE INTERRUPT

SP + 8	RTN _L	
SP + 6	Y _L	RTN _H
SP + 4	X _L	Y _H
SP + 2	A	X _H
SP	CCR	B
SP - 2		

STACK UPON ENTRY TO SERVICE ROUTINE
IF SP WAS EVEN BEFORE INTERRUPT

SP + 9			SP + 10
SP + 7	RTN _H	RTN _L	SP + 8
SP + 5	Y _H	Y _L	SP + 6
SP + 3	X _H	X _L	SP + 4
SP + 1	B	A	SP + 2
SP - 1		CCR	SP

Figure 2 Stack and Memory Layout

Stack pointer (SP) points to the last stack location used. The STAR12 CPU supports an automatic program stack that is used to save system context during subroutine calls and interrupts, and can also be used for

Central Processing Unit (CPU)

temporary storage of data. The stack pointer can also be used in all indexed addressing modes.

Program counter is a 16-bit register that holds the address of the next instruction to be executed. The program counter can be used in all indexed addressing modes except autoincrement/decrement.

Condition Code Register (CCR) contains five status indicators, two interrupt masking bits, and a STOP disable bit. The five flags are half carry (H), negative (N), zero (Z), overflow (V), and carry/borrow (C). The half-carry flag is used only for BCD arithmetic operations. The N, Z, V, and C status bits allow for branching based on the results of a previous operation.

Data Types

The STAR12 CPU supports the following data types:

- Bit data
- 8-bit and 16-bit signed and unsigned integers
- 16-bit unsigned fractions
- 16-bit addresses

A byte is eight bits wide and can be accessed at any byte location. A word is composed of two consecutive bytes with the most significant byte at the lower value address. There are no special requirements for alignment of instructions or operands.

Addressing Modes

Addressing modes determine how the CPU accesses memory locations to be operated upon. The STAR12 CPU includes all of the addressing modes of the M68HC11 CPU as well as several new forms of indexed addressing. [Table 3](#) is a summary of the available addressing modes.

Table 3 M68HC12 Addressing Mode Summary

Addressing Mode	Source Format	Abbreviation	Description
Inherent	INST (no externally supplied operands)	INH	Operands (if any) are in CPU registers
Immediate	INST #opr8i or INST #opr16i	IMM	Operand is included in instruction stream 8- or 16-bit size implied by context
Direct	INST opr8a	DIR	Operand is the lower 8-bits of an address in the range \$0000 – \$00FF
Extended	INST opr16a	EXT	Operand is a 16-bit address
Relative	INST rel8 or INST rel16	REL	An 8-bit or 16-bit relative offset from the current pc is supplied in the instruction
Indexed (5-bit offset)	INST oprx5,xysp	IDX	5-bit signed constant offset from x, y, sp, or pc
Indexed (auto pre-decrement)	INST oprx3,-xys	IDX	Auto pre-decrement x, y, or sp by 1 ~ 8
Indexed (auto pre-increment)	INST oprx3,+xys	IDX	Auto pre-increment x, y, or sp by 1 ~ 8
Indexed (auto post-decrement)	INST oprx3,xys-	IDX	Auto post-decrement x, y, or sp by 1 ~ 8
Indexed (auto post-increment)	INST oprx3,xys+	IDX	Auto post-increment x, y, or sp by 1 ~ 8
Indexed (accumulator offset)	INST abd,xysp	IDX	Indexed with 8-bit (A or B) or 16-bit (D) accumulator offset from x, y, sp, or pc
Indexed (9-bit offset)	INST oprx9,xysp	IDX1	9-bit signed constant offset from x, y, sp, or pc (lower 8-bits of offset in one extension byte)
Indexed (16-bit offset)	INST oprx16,xysp	IDX2	16-bit constant offset from x, y, sp, or pc (16-bit offset in two extension bytes)
Indexed-Indirect (16-bit offset)	INST [oprx16,xysp]	[IDX2]	Pointer to operand is found at... 16-bit constant offset from x, y, sp, or pc (16-bit offset in two extension bytes)
Indexed-Indirect (D accumulator offset)	INST [D,xysp]	[D,IDX]	Pointer to operand is found at... x, y, sp, or pc plus the value in D

Indexed Addressing Modes

The STAR12 CPU indexed modes reduce execution time and eliminate code size penalties for using the Y index register. STAR12 CPU indexed addressing uses a postbyte plus zero, one, or two extension bytes after the instruction opcode. The postbyte and extensions do the following tasks:

- Specify which index register is used.
- Determine whether a value in an accumulator is used as an offset.
- Enable automatic pre- or post-increment or decrement
- Specify use of 5-bit, 9-bit, or 16-bit signed offsets.

Table 4 Summary of Indexed Operations

Postbyte Code (xb)	Source Code Syntax	Comments
rr0nnnnn	,r n,r -n,r	5-bit constant offset n = -16 to +15 rr can specify X, Y, SP, or PC
111rr0zs	n,r -n,r	Constant offset (9- or 16-bit signed) z=0 = 9-bit with sign in LSB of postbyte(s) 1 = 16-bit if z = s = 1, 16-bit offset indexed-indirect (see below) rr can specify X, Y, SP, or PC
111rr011	[n,r]	16-bit offset indexed-indirect rr can specify X, Y, SP, or PC
rr1pnnnn	n,-r n,+r n,r- n,r+	Auto pre-decrement/increment or Auto post-decrement/increment; p = pre-(0) or post-(1), n = -8 to -1, +1 to +8 rr can specify X, Y, or SP (PC not a valid choice)
111rr1aa	A,r B,r D,r	Accumulator offset (unsigned 8-bit or 16-bit) aa=00 = A 01 = B 10 = D (16-bit) 11 = see accumulator D offset indexed-indirect rr can specify X, Y, SP, or PC
111rr111	[D,r]	Accumulator D offset indexed-indirect rr can specify X, Y, SP, or PC



Opcodes and Operands

The STAR12 CPU uses 8-bit opcodes. Each opcode identifies a particular instruction and associated addressing mode to the CPU. Several opcodes are required to provide each instruction with a range of addressing capabilities.

Only 256 opcodes would be available if the range of values were restricted to the number that can be represented by 8-bit binary numbers. To expand the number of opcodes, a second page is added to the opcode map. Opcodes on the second page are preceded by an additional byte with the value \$18.

To provide additional addressing flexibility, opcodes can also be followed by a postbyte or extension bytes. Postbytes implement certain forms of indexed addressing, transfers, exchanges, and loop primitives. Extension bytes contain additional program information such as addresses, offsets, and immediate data.

Instruction Set Summary

The following table defines the special characters used to describe the effects of instruction execution on the status bits in the condition codes register (SXHINZVC column).

Table 5 Condition Code Changes

Special Character	Description
-	Status bit not affected by operation.
0	Status bit cleared by operation.
1	Status bit set by operation.
△	Status bit affected by operation.
⇓	Status bit may be cleared or remain set, but is not set by operation.
⇑	Status bit may be set or remain cleared, but the final state is not defined.
?	Status bit may be changed by operation but the final state is not defined.
!	Status bit used for a special purpose.

Source Form	Operation	Address Mode	Machine Coding (Hex)	Access Detail	S X H I N Z V C
ABA	Add B to A; (A)+(B)⇒A	INH	18 06	OO	- - △ - △ △ △ △
ABX	Add B to X; (X)+(B)⇒X; assembles as LEAX B,X	IDX	1A E5	Pf	- - - - - - - -
ABY	Add B to Y; (Y)+(B)⇒Y; assembles as LEAY B,Y	IDX	19 ED	Pf	- - - - - - - -
ADCA #opr8i ADCA opr8a ADCA opr16a ADCA oprx0_xysppc ADCA oprx9_xysppc ADCA oprx16_xysppc ADCA [D,xysppc] ADCA [oprx16,xysppc]	Add with carry to A; (A)+(M)+C⇒A or (A)+imm+C⇒A	IMM DIR EXT IDX IDX1 IDX2 [D,IDX] [IDX2]	89 ii 99 dd B9 hh ll A9 xb A9 xb ff A9 xb ee ff A9 xb A9 xb ee ff	P rPf rPO rPf rPO frPP fIf rPf fIP rPf	- - △ - △ △ △ △

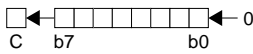
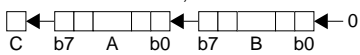

Source Form	Operation	Address Mode	Machine Coding (Hex)	Access Detail	S X H I N Z V C
ADCB #opr8i ADCB opr8a ADCB opr16a ADCB oprx0_xysppc ADCB oprx9_xysppc ADCB oprx16_xysppc ADCB [D,xysppc] ADCB [oprx16,xysppc]	Add with carry to B; (B)+(M)+C⇒B or (B)+imm+C⇒B	IMM DIR EXT IDX IDX1 IDX2 [D,IDX] [IDX2]	C9 ii D9 dd F9 hh ll E9 xb E9 xb ff E9 xbee ff E9 xb E9 xbee ff	P rPf rPO rPf rPO frPP fIfrPf fIPrPf	[- - Δ - Δ Δ Δ Δ Δ]
ADDA #opr8i ADDA opr8a ADDA opr16a ADDA oprx0_xysppc ADDA oprx9_xysppc ADDA oprx16_xysppc ADDA [D,xysppc] ADDA [oprx16,xysppc]	Add to A; (A)+(M)⇒A or (A)+imm⇒A	IMM DIR EXT IDX IDX1 IDX2 [D,IDX] [IDX2]	8B ii 9B dd BB hh ll AB xb AB xb ff AB xbee ff AB xb AB xbee ff	P rPf rPO rPf rPO frPP fIfrPf fIPrPf	[- - Δ - Δ Δ Δ Δ Δ]
ADDB #opr8i ADDB opr8a ADDB opr16a ADDB oprx0_xysppc ADDB oprx9_xysppc ADDB oprx16_xysppc ADDB [D,xysppc] ADDB [oprx16,xysppc]	Add to B; (B)+(M)⇒B or (B)+imm⇒B	IMM DIR EXT IDX IDX1 IDX2 [D,IDX] [IDX2]	CB ii DB dd FB hh ll EB xb EB xb ff EB xbee ff EB xb EB xbee ff	P rPf rPO rPf rPO frPP fIfrPf fIPrPf	[- - Δ - Δ Δ Δ Δ Δ]
ADDD #opr16i ADDD opr8a ADDD opr16a ADDD oprx0_xysppc ADDD oprx9_xysppc ADDD oprx16_xysppc ADDD [D,xysppc] ADDD [oprx16,xysppc]	Add to D; (A:B)+(M:M+1)⇒A:B or (A:B)+imm⇒A:B	IMM DIR EXT IDX IDX1 IDX2 [D,IDX] [IDX2]	C3 jj kk D3 dd F3 hh ll E3 xb E3 xb ff E3 xbee ff E3 xb E3 xbee ff	PO RPf RPO RPf RPO frPP fIfrPf fIPrPf	[- - - - Δ Δ Δ Δ Δ]
ANDA #opr8i ANDA opr8a ANDA opr16a ANDA oprx0_xysppc ANDA oprx9_xysppc ANDA oprx16_xysppc ANDA [D,xysppc] ANDA [oprx16,xysppc]	AND with A; (A)•(M)⇒A or (A)•imm⇒A	IMM DIR EXT IDX IDX1 IDX2 [D,IDX] [IDX2]	84 ii 94 dd B4 hh ll A4 xb A4 xb ff A4 xbee ff A4 xb A4 xbee ff	P rPf rPO rPf rPO frPP fIfrPf fIPrPf	[- - - - Δ Δ Δ 0 -]
ANDB #opr8i ANDB opr8a ANDB opr16a ANDB oprx0_xysppc ANDB oprx9_xysppc ANDB oprx16_xysppc ANDB [D,xysppc] ANDB [oprx16,xysppc]	AND with B; (B)•(M)⇒B or (B)•imm⇒B	IMM DIR EXT IDX IDX1 IDX2 [D,IDX] [IDX2]	C4 ii D4 dd F4 hh ll E4 xb E4 xb ff E4 xbee ff E4 xb E4 xbee ff	P rPf rPO rPf rPO frPP fIfrPf fIPrPf	[- - - - Δ Δ Δ 0 -]
ANDCC #opr8i	AND with CCR; (CCR)•imm⇒CCR	IMM	10 ii	P	↓ ↓ ↓ ↓ ↓ ↓ ↓ ↓ ↓ ↓
ASL opr16a ASL oprx0_xysp ASL oprx9_xysppc ASL oprx16_xysppc ASL [D,xysppc] ASL [oprx16_xysppc] ASLA ASLB	Arithmetic shift left M; same as LSL  Arithmetic shift left A; same as LSLA Arithmetic shift left B; same as LSLB	EXT IDX IDX1 IDX2 [D,IDX] [IDX2] INH INH	78 hh ll 68 xb 68 xb ff 68 xbee ff 68 xb 68 xbee ff 48 58	rPwO rPw rPwO frPwP fIfrPw fIPrPw O O	[- - - - Δ Δ Δ Δ Δ]
ASLD	Arithmetic shift left D; same as LSLD 	INH	59	O	[- - - - Δ Δ Δ Δ Δ]

Central Processing Unit (CPU)

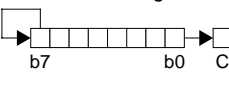
Source Form	Operation	Address Mode	Machine Coding (Hex)	Access Detail	S X H I N Z V C									
ASR <i>opr16a</i> ASR <i>opr0_xysppc</i> ASR <i>opr9_xysppc</i> ASR <i>opr16_xysppc</i> ASR [D, <i>xysppc</i>] ASR [<i>opr16_xysppc</i>] ASRA ASRB	Arithmetic shift right M 	EXT IDX IDX1 IDX2 [D,IDX] [IDX2]	77 hh ll 67 xb 67 xb ff 67 xb ee ff 67 xb 67 xb ee ff	rPwO rPw rPwO frPwP fIfrPw fIPrPw O O	<table border="1"><tr><td>-</td><td>-</td><td>-</td><td>-</td><td>-</td><td>Δ</td><td>Δ</td><td>Δ</td><td>Δ</td></tr></table>	-	-	-	-	-	Δ	Δ	Δ	Δ
-	-	-	-	-	Δ	Δ	Δ	Δ						
BCC <i>rel8</i>	Branch if C clear; if C=0, then (PC)+2+rel⇒PC; same as BHS	REL	24 rr	PPP (branch) P (no branch)	<table border="1"><tr><td>-</td><td>-</td><td>-</td><td>-</td><td>-</td><td>-</td><td>-</td><td>-</td><td>-</td></tr></table>	-	-	-	-	-	-	-	-	-
-	-	-	-	-	-	-	-	-						
BCLR <i>opr8a, msk8</i> BCLR <i>opr16a, msk8</i> BCLR <i>opr0_xysppc, msk8</i> BCLR <i>opr9_xysppc, msk8</i> BCLR <i>opr16_xysppc, msk8</i>	Clear bit(s) in M; (M)•(mask byte)⇒M	DIR EXT IDX IDX1 IDX2	4D dd mm 1D hh ll mm 0D xb mm 0D xb ff mm 0D xb ee ff mm	rPwO rPwP rPwO rPwP frPwPO	<table border="1"><tr><td>-</td><td>-</td><td>-</td><td>-</td><td>-</td><td>Δ</td><td>Δ</td><td>0</td><td>-</td></tr></table>	-	-	-	-	-	Δ	Δ	0	-
-	-	-	-	-	Δ	Δ	0	-						
BCS <i>rel8</i>	Branch if C set; if C=1, then (PC)+2+rel⇒PC; same as BLO	REL	25 rr	PPP (branch) P (no branch)	<table border="1"><tr><td>-</td><td>-</td><td>-</td><td>-</td><td>-</td><td>-</td><td>-</td><td>-</td><td>-</td></tr></table>	-	-	-	-	-	-	-	-	-
-	-	-	-	-	-	-	-	-						
BEQ <i>rel8</i>	Branch if equal; if Z=1, then (PC)+2+rel⇒PC	REL	27 rr	PPP (branch) P (no branch)	<table border="1"><tr><td>-</td><td>-</td><td>-</td><td>-</td><td>-</td><td>-</td><td>-</td><td>-</td><td>-</td></tr></table>	-	-	-	-	-	-	-	-	-
-	-	-	-	-	-	-	-	-						
BGE <i>rel8</i>	Branch if ≥ 0, signed; if N⊕V=0, then (PC)+2+rel⇒PC	REL	2C rr	PPP (branch) P (no branch)	<table border="1"><tr><td>-</td><td>-</td><td>-</td><td>-</td><td>-</td><td>-</td><td>-</td><td>-</td><td>-</td></tr></table>	-	-	-	-	-	-	-	-	-
-	-	-	-	-	-	-	-	-						
BGND	Enter background debug mode	INH	00	VfPPP	<table border="1"><tr><td>-</td><td>-</td><td>-</td><td>-</td><td>-</td><td>-</td><td>-</td><td>-</td><td>-</td></tr></table>	-	-	-	-	-	-	-	-	-
-	-	-	-	-	-	-	-	-						
BGT <i>rel8</i>	Branch if > 0, signed; if Z (N⊕V)=0, then (PC)+2+rel⇒PC	REL	2E rr	PPP (branch) P (no branch)	<table border="1"><tr><td>-</td><td>-</td><td>-</td><td>-</td><td>-</td><td>-</td><td>-</td><td>-</td><td>-</td></tr></table>	-	-	-	-	-	-	-	-	-
-	-	-	-	-	-	-	-	-						
BHI <i>rel8</i>	Branch if higher, unsigned; if C Z=0, then (PC)+2+rel⇒PC	REL	22 rr	PPP (branch) P (no branch)	<table border="1"><tr><td>-</td><td>-</td><td>-</td><td>-</td><td>-</td><td>-</td><td>-</td><td>-</td><td>-</td></tr></table>	-	-	-	-	-	-	-	-	-
-	-	-	-	-	-	-	-	-						
BHS <i>rel8</i>	Branch if higher or same, unsigned; if C=0, then (PC)+2+rel⇒PC; same as BCC	REL	24 rr	PPP (branch) P (no branch)	<table border="1"><tr><td>-</td><td>-</td><td>-</td><td>-</td><td>-</td><td>-</td><td>-</td><td>-</td><td>-</td></tr></table>	-	-	-	-	-	-	-	-	-
-	-	-	-	-	-	-	-	-						
BITA # <i>opr8i</i> BITA <i>opr8a</i> BITA <i>opr16a</i> BITA <i>opr0_xysppc</i> BITA <i>opr9_xysppc</i> BITA <i>opr16_xysppc</i> BITA [D, <i>xysppc</i>] BITA [<i>opr16_xysppc</i>]	Bit test A; (A)•(M) or (A)•imm	IMM DIR EXT IDX IDX1 IDX2 [D,IDX] [IDX2]	85 ii 95 dd B5 hh ll A5 xb A5 xb ff A5 xb ee ff A5 xb A5 xb ee ff	P rPf rPO rPf rPO frPP fIfrPf fIPrPf	<table border="1"><tr><td>-</td><td>-</td><td>-</td><td>-</td><td>-</td><td>Δ</td><td>Δ</td><td>0</td><td>-</td></tr></table>	-	-	-	-	-	Δ	Δ	0	-
-	-	-	-	-	Δ	Δ	0	-						
BITB # <i>opr8i</i> BITB <i>opr8a</i> BITB <i>opr16a</i> BITB <i>opr0_xysppc</i> BITB <i>opr9_xysppc</i> BITB <i>opr16_xysppc</i> BITB [D, <i>xysppc</i>] BITB [<i>opr16_xysppc</i>]	Bit test B; (B)•(M) or (B)•imm	IMM DIR EXT IDX IDX1 IDX2 [D,IDX] [IDX2]	C5 ii D5 dd F5 hh ll E5 xb E5 xb ff E5 xb ee ff E5 xb E5 xb ee ff	P rPf rPO rPf rPO frPP fIfrPf fIPrPf	<table border="1"><tr><td>-</td><td>-</td><td>-</td><td>-</td><td>-</td><td>Δ</td><td>Δ</td><td>0</td><td>-</td></tr></table>	-	-	-	-	-	Δ	Δ	0	-
-	-	-	-	-	Δ	Δ	0	-						
BLE <i>rel8</i>	Branch if ≤ 0, signed; if Z (N⊕V)=1, then (PC)+2+rel⇒PC	REL	2F rr	PPP (branch) P (no branch)	<table border="1"><tr><td>-</td><td>-</td><td>-</td><td>-</td><td>-</td><td>-</td><td>-</td><td>-</td><td>-</td></tr></table>	-	-	-	-	-	-	-	-	-
-	-	-	-	-	-	-	-	-						
BLO <i>rel8</i>	Branch if lower, unsigned; if C=1, then (PC)+2+rel⇒PC; same as BCS	REL	25 rr	PPP (branch) P (no branch)	<table border="1"><tr><td>-</td><td>-</td><td>-</td><td>-</td><td>-</td><td>-</td><td>-</td><td>-</td><td>-</td></tr></table>	-	-	-	-	-	-	-	-	-
-	-	-	-	-	-	-	-	-						
BLS <i>rel8</i>	Branch if lower or same, unsigned; if C Z=1, then (PC)+2+rel⇒PC	REL	23 rr	PPP (branch) P (no branch)	<table border="1"><tr><td>-</td><td>-</td><td>-</td><td>-</td><td>-</td><td>-</td><td>-</td><td>-</td><td>-</td></tr></table>	-	-	-	-	-	-	-	-	-
-	-	-	-	-	-	-	-	-						
BLT <i>rel8</i>	Branch if < 0, signed; if N⊕V=1, then (PC)+2+rel⇒PC	REL	2D rr	PPP (branch) P (no branch)	<table border="1"><tr><td>-</td><td>-</td><td>-</td><td>-</td><td>-</td><td>-</td><td>-</td><td>-</td><td>-</td></tr></table>	-	-	-	-	-	-	-	-	-
-	-	-	-	-	-	-	-	-						
BMI <i>rel8</i>	Branch if minus; if N=1, then (PC)+2+rel⇒PC	REL	2B rr	PPP (branch) P (no branch)	<table border="1"><tr><td>-</td><td>-</td><td>-</td><td>-</td><td>-</td><td>-</td><td>-</td><td>-</td><td>-</td></tr></table>	-	-	-	-	-	-	-	-	-
-	-	-	-	-	-	-	-	-						
BNE <i>rel8</i>	Branch if not equal to 0; if Z=0, then (PC)+2+rel⇒PC	REL	26 rr	PPP (branch) P (no branch)	<table border="1"><tr><td>-</td><td>-</td><td>-</td><td>-</td><td>-</td><td>-</td><td>-</td><td>-</td><td>-</td></tr></table>	-	-	-	-	-	-	-	-	-
-	-	-	-	-	-	-	-	-						



Source Form	Operation	Address Mode	Machine Coding (Hex)	Access Detail	S X H I N Z V C
BPL <i>rel8</i>	Branch if plus; if N=0, then (PC)+2+rel→PC	REL	2A rr	PPP (branch) P (no branch)	[- - - - - - - -]
BRA <i>rel8</i>	Branch always	REL	20 rr	PPP	[- - - - - - - -]
BRCLR <i>opr8a, msk8, rel8</i> BRCLR <i>opr16a, msk8, rel8</i> BRCLR <i>opr0_xysppc, msk8, rel8</i> BRCLR <i>opr9_xysppc, msk8, rel8</i> BRCLR <i>opr16_xysppc, msk8, rel8</i>	Branch if bit(s) clear; if (M)•(mask byte)=0, then (PC)+2+rel→PC	DIR EXT IDX IDX1 IDX2	4F dd mm rr 1F hh ll mm rr 0F xb mm rr 0F xb ff mm rr 0F xbee ff mm rr	rPPP rfPPP rPPP rfPPP PrfPPP	[- - - - - - - -]
BRN <i>rel8</i>	Branch never	REL	21 rr	P	[- - - - - - - -]
BRSET <i>opr8, msk8, rel8</i> BRSET <i>opr16a, msk8, rel8</i> BRSET <i>opr0_xysppc, msk8, rel8</i> BRSET <i>opr9_xysppc, msk8, rel8</i> BRSET <i>opr16_xysppc, msk8, rel8</i>	Branch if bit(s) set; if (M)•(mask byte)=0, then (PC)+2+rel→PC	DIR EXT IDX IDX1 IDX2	4E dd mm rr 1E hh ll mm rr 0E xb mm rr 0E xb ff mm rr 0E xbee ff mm rr	rPPP rfPPP rPPP rfPPP PrfPPP	[- - - - - - - -]
BSET <i>opr8, msk8</i> BSET <i>opr16a, msk8</i> BSET <i>opr0_xysppc, msk8</i> BSET <i>opr9_xysppc, msk8</i> BSET <i>opr16_xysppc, msk8</i>	Set bit(s) in M; (M) (mask byte)→M	DIR EXT IDX IDX1 IDX2	4C dd mm 1C hh ll mm 0C xb mm 0C xb ff mm 0C xbee ff mm	rPwO rPwP rPwO rPwP frPwPO	[- - - - - Δ Δ 0 -]
BSR <i>rel8</i>	Branch to subroutine; (SP)-2→SP; RTN _H :RTN _L →M _{SP} :M _{SP+1} ; (PC)+2+rel→PC	REL	07 rr	SPPP	[- - - - - - - -]
BVC <i>rel8</i>	Branch if V clear; if V=0, then (PC)+2+rel→PC	REL	28 rr	PPP (branch) P (no branch)	[- - - - - - - -]
BVS <i>rel8</i>	Branch if V set; if V=1, then (PC)+2+rel→PC	REL	29 rr	PPP (branch) P (no branch)	[- - - - - - - -]
CALL <i>opr16a, page</i> CALL <i>opr0_xysppc, page</i> CALL <i>opr9_xysppc, page</i> CALL <i>opr16_xysppc, page</i> CALL [D, <i>xysppc</i>] CALL [<i>opr16, xysppc</i>]	Call subroutine in expanded memory; (SP)-2→SP; RTN _H :RTN _L →M _{SP} :M _{SP+1} ; (SP)-1→SP; (PPG)→M _{SP} ; pg→PPAGE register; subroutine address→PC	EXT IDX IDX1 IDX2 [D,IDX] [IDX2]	4A hh ll pg 4B xb pg 4B xb ff pg 4B xbee ff pg 4B xb 4B xbee ff	gnSsPPP gnSsPPP gnSsPPP fgnSsPPP fIignSsPPP fIignSsPPP	[- - - - - - - -]
CBA	Compare A to B; (A)-(B)	INH	18 17	OO	[- - - - - Δ Δ Δ Δ]
CLC	Clear C; assembles as ANDCC #SFE	IMM	10 FE	P	[- - - - - - - 0]
CLI	Clear I; assembles as ANDCC #SEF	IMM	10 EF	P	[- - - 0 - - - -]
CLR <i>opr16a</i> CLR <i>opr0_xysppc</i> CLR <i>opr9_xysppc</i> CLR <i>opr16_xysppc</i> CLR [D, <i>xysppc</i>] CLR [<i>opr16_xysppc</i>] CLRA CLRB	Clear M; \$00→M Clear A; \$00→A Clear B; \$00→B	EXT IDX IDX1 IDX2 [D,IDX] [IDX2] INH INH	79 hh ll 69 xb 69 xb ff 69 xbee ff 69 xb 69 xbee ff 87 C7	PwO Pw PwO PwP PIfw PIPw O O	[- - - - - 0 1 0 0]
CLV	Clear V; assembles as ANDCC #SFD	IMM	10 FD	P	[- - - - - - - 0 -]
CMPA # <i>opr8i</i> CMPA <i>opr8a</i> CMPA <i>opr16a</i> CMPA <i>opr0_xysppc</i> CMPA <i>opr9_xysppc</i> CMPA <i>opr16_xysppc</i> CMPA [D, <i>xysppc</i>] CMPA [<i>opr16_xysppc</i>]	Compare A; (A)-(M) or (A)-imm	IMM DIR EXT IDX IDX1 IDX2 [D,IDX] [IDX2]	81 ii 91 dd B1 hh ll A1 xb A1 xb ff A1 xbee ff A1 xb A1 xbee ff	P rPf rPO rPf rPO frPP fIfrPf fIPrPf	[- - - - - Δ Δ Δ Δ Δ]



Central Processing Unit (CPU)

Source Form	Operation	Address Mode	Machine Coding (Hex)	Access Detail	S X H I N Z V C
CMPB #opr8i CMPB opr8a CMPB opr16a CMPB oprx0_xysppc CMPB oprx9_xysppc CMPB oprx16_xysppc CMPB [D_xysppc] CMPB [oprx16_xysppc]	Compare B; (B)–(M) or (B)–imm	IMM DIR EXT IDX IDX1 IDX2 [D,IDX] [IDX2]	C1 ii D1 dd F1 hh ll E1 xb E1 xb ff E1 xb ee ff E1 xb E1 xb ee ff	P rPf rPO rPf rPO frPP fIfrPf fIfrPf	[-][-][-][Δ][Δ][Δ][Δ]
COM opr16a COM oprx0_xysppc COM oprx9_xysppc COM oprx16_xysppc COM [D_xysppc] COM [oprx16_xysppc] COMA COMB	Complement M; $(\bar{M}) = \$FF - (M) \Rightarrow M$ Complement A; $(\bar{A}) = \$FF - (A) \Rightarrow A$ Complement B; $(\bar{B}) = \$FF - (B) \Rightarrow B$	EXT IDX IDX1 IDX2 [D,IDX] [IDX2] INH INH	71 hh ll 61 xb 61 xb ff 61 xb ee ff 61 xb 61 xb ee ff 41 51	rPwO rPw rPwO frPwP fIfrPw fIfrPw O O	[-][-][-][Δ][Δ][0][1]
CPD #opr16i CPD opr8a CPD opr16a CPD oprx0_xysppc CPD oprx9_xysppc CPD oprx16_xysppc CPD [D_xysppc] CPD [oprx16_xysppc]	Compare D; (A:B)–(M:M+1) or (A:B)–imm	IMM DIR EXT IDX IDX1 IDX2 [D,IDX] [IDX2]	8C jj kk 9C dd BC hh ll AC xb AC xb ff AC xb ee ff AC xb AC xb ee ff	PO RPf RPO RPf RPO frPP fIfrPf fIfrPf	[-][-][-][Δ][Δ][Δ][Δ]
CPS #opr16i CPS opr8a CPS opr16a CPS oprx0_xysppc CPS oprx9_xysppc CPS oprx16_xysppc CPS [D_xysppc] CPS [oprx16_xysppc]	Compare SP; (SP)–(M:M+1) or (SP)–imm	IMM DIR EXT IDX IDX1 IDX2 [D,IDX] [IDX2]	8F jj kk 9F dd BF hh ll AF xb AF xb ff AF xb ee ff AF xb AF xb ee ff	PO RPf RPO RPf RPO frPP fIfrPf fIfrPf	[-][-][-][Δ][Δ][Δ][Δ]
CPX #opr16i CPX opr8a CPX opr16a CPX oprx0_xysppc CPX oprx9_xysppc CPX oprx16_xysppc CPX [D_xysppc] CPX [oprx16_xysppc]	Compare X; (X)–(M:M+1) or (X)–imm	IMM DIR EXT IDX IDX1 IDX2 [D,IDX] [IDX2]	8E jj kk 9E dd BE hh ll AE xb AE xb ff AE xb ee ff AE xb AE xb ee ff	PO RPf RPO RPf RPO frPP fIfrPf fIfrPf	[-][-][-][Δ][Δ][Δ][Δ]
CPY #opr16i CPY opr8a CPY opr16a CPY oprx0_xysppc CPY oprx9_xysppc CPY oprx16_xysppc CPY [D_xysppc] CPY [oprx16_xysppc]	Compare Y; (Y)–(M:M+1) or (Y)–imm	IMM DIR EXT IDX IDX1 IDX2 [D,IDX] [IDX2]	8D jj kk 9D dd BD hh ll AD xb AD xb ff AD xb ee ff AD xb AD xb ee ff	PO RPf RPO RPf RPO frPP fIfrPf fIfrPf	[-][-][-][Δ][Δ][Δ][Δ]
DAA	Decimal adjust A for BCD	INH	18 07	Ofo	[-][-][-][Δ][Δ][?][Δ]
DBEQ abdxysp, rel9	Decrement and branch if equal to 0; (counter)–1⇒counter; if (counter)=0, then branch	REL (9-bit)	04 1brr	PPP (branch) PPO (no branch)	[-][-][-][-][-][-]
DBNE abdxysp, rel9	Decrement and branch if not equal to 0; (counter)–1⇒counter; if (counter)≠0, then branch	REL (9-bit)	04 1brr	PPP (branch) PPO (no branch)	[-][-][-][-][-][-]



Source Form	Operation	Address Mode	Machine Coding (Hex)	Access Detail	S X H I N Z V C
DEC <i>opr16a</i> DEC <i>opr0_xysppc</i> DEC <i>opr9_xysppc</i> DEC <i>opr16_xysppc</i> DEC [D, <i>xysppc</i>] DEC [<i>opr16_xysppc</i>] DECA DECB	Decrement M; (M)-1⇒M Decrement A; (A)-1⇒A Decrement B; (B)-1⇒B	EXT IDX IDX1 IDX2 [D,IDX] [IDX2] INH INH	73 hh 11 63 xb 63 xb ff 63 xb ee ff 63 xb 63 xb ee ff 43 53	rPwO rPw rPwO frPwP fIfrPw fIPrPw O O	[- - - - Δ Δ Δ Δ -]
DES	Decrement SP; (SP)-1⇒SP; assembles as LEAS-1,SP	IDX	1B 9F	Pf	[- - - - - - - -]
DEX	Decrement X; (X)-1⇒X	INH	09	O	[- - - - - Δ - -]
DEY	Decrement Y; (Y)-1⇒Y	INH	03	O	[- - - - - Δ - -]
EDIV	Extended divide, unsigned; 32 by 16 to 16-bit; (Y:D)÷(X)⇒Y; remainder⇒D	INH	11	ffffffffff0	[- - - - - Δ Δ Δ Δ Δ]
EDIVS	Extended divide, signed; 32 by 16 to 16-bit; (Y:D)÷(X)⇒Y; remainder⇒D	INH	18 14	Offffffffffff0	[- - - - - Δ Δ Δ Δ Δ]
EMACS <i>opr16a</i>	Extended multiply and accumulate, signed; (M _X :M _{X+1})×(M _Y :M _{Y+1})+ (M-M+3)⇒M-M+3; 16 by 16 to 32-bit	Special	18 12 hh 11	ORROffRRfWWP	[- - - - - Δ Δ Δ Δ Δ]
EMAXD <i>opr0_xysppc</i> EMAXD <i>opr9_xysppc</i> EMAXD <i>opr16_xysppc</i> EMAXD [D, <i>xysppc</i>] EMAXD [<i>opr16_xysppc</i>]	Extended maximum in D; put larger of 2 unsigned 16-bit values in D; MAX[(D), (M:M+1)]⇒D; N, Z, V, C bits reflect result of internal compare [(D)-(M:M+1)]	IDX IDX1 IDX2 [D,IDX] [IDX2]	18 1A xb 18 1A xb ff 18 1A xb ee ff 18 1A xb 18 1A xb ee ff	ORPf ORPO OfRPP OfIfRPf OfIPRPf	[- - - - - Δ Δ Δ Δ Δ]
EMAXM <i>opr0_xysppc</i> EMAXM <i>opr9_xysppc</i> EMAXM <i>opr16_xysppc</i> EMAXM [D, <i>xysppc</i>] EMAXM [<i>opr16_xysppc</i>]	Extended maximum in M; put larger of 2 unsigned 16-bit values in M; MAX[(D), (M:M+1)]⇒M:M+1; N, Z, V, C bits reflect result of internal compare [(D)-(M:M+1)]	IDX IDX1 IDX2 [D,IDX] [IDX2]	18 1E xb 18 1E xb ff 18 1E xb ee ff 18 1E xb 18 1E xb ee ff	ORPW ORPWO OfRPWP OfIfRPW OfIPRPW	[- - - - - Δ Δ Δ Δ Δ]
EMIND <i>opr0_xysppc</i> EMIND <i>opr9_xysppc</i> EMIND <i>opr16_xysppc</i> EMIND [D, <i>xysppc</i>] EMIND [<i>opr16_xysppc</i>]	Extended minimum in D; put smaller of 2 unsigned 16-bit values in D; MIN[(D), (M:M+1)]⇒D; N, Z, V, C bits reflect result of internal compare [(D)-(M:M+1)]	IDX IDX1 IDX2 [D,IDX] [IDX2]	18 1B xb 18 1B xb ff 18 1B xb ee ff 18 1B xb 18 1B xb ee ff	ORPf ORPO OfRPP OfIfRPf OfIPRPf	[- - - - - Δ Δ Δ Δ Δ]
EMINM <i>opr0_xysppc</i> EMINM <i>opr9_xysppc</i> EMINM <i>opr16_xysppc</i> EMINM [D, <i>xysppc</i>] EMINM [<i>opr16_xysppc</i>]	Extended minimum in M; put smaller of 2 unsigned 16-bit values in M; MIN[(D), (M:M+1)]⇒M:M+1; N, Z, V, C bits reflect result of internal compare [(D)-(M:M+1)]	IDX IDX1 IDX2 [D,IDX] [IDX2]	18 1F xb 18 1F xb ff 18 1F xb ee ff 18 1F xb 18 1F xb ee ff	ORPW ORPWO OfRPWP OfIfRPW OfIPRPW	[- - - - - Δ Δ Δ Δ Δ]
EMUL	Extended multiply, unsigned; (D)×(Y)⇒Y:D; 16 by 16 to 32-bit	INH	13	ff0	[- - - - - Δ Δ Δ Δ Δ]
EMULS	Extended multiply, signed; (D)×(Y)⇒Y:D; 16 by 16 to 32-bit	INH	18 13	Of0 Of0 (if followed by page 2 instruction)	[- - - - - Δ Δ Δ Δ Δ]
EORA # <i>opr8i</i> EORA <i>opr8a</i> EORA <i>opr16a</i> EORA <i>opr0_xysppc</i> EORA <i>opr9_xysppc</i> EORA <i>opr16_xysppc</i> EORA [D, <i>xysppc</i>] EORA [<i>opr16_xysppc</i>]	Exclusive OR A; (A)⊕(M)⇒A or (A)⊕imm⇒A	IMM DIR EXT IDX IDX1 IDX2 [D,IDX] [IDX2]	88 ii 98 dd B8 hh 11 A8 xb A8 xb ff A8 xb ee ff A8 xb A8 xb ee ff	P rPf rPO rPf rPO frPP fIfrPf fIPrPf	[- - - - - Δ Δ Δ 0 -]

Central Processing Unit (CPU)

Source Form	Operation	Address Mode	Machine Coding (Hex)	Access Detail	S X H I N Z V C
EORB #opr8i EORB opr8a EORB opr16a EORB oprx0_xysppc EORB oprx9_xysppc EORB oprx16_xysppc EORB [D_xysppc] EORB [opr16_xysppc]	Exclusive OR B; (B)⊕(M)⇒B or (B)⊕imm⇒B	IMM DIR EXT IDX IDX1 IDX2 [D,IDX] [IDX2]	C8 ii D8 dd F8 hh ll E8 xb E8 xb ff E8 xb ee ff E8 xb E8 xb ee ff	P rPf rPO rPf rPO frPP fIfrPf fIPrPf	[- - - - Δ Δ 0 -]
ETBL oprx0_xysppc	Extended table lookup and interpolate, 16-bit; (M:M+1)+(B)× ((M+2:M+3)-(M:M+1))⇒D	IDX	18 3F xb	ORRfffffP	[- - - - Δ Δ - Δ]
Before executing ETBL, initialize B with fractional part of lookup value; initialize index register to point to first table entry (M:M+1). No extensions or indirect addressing allowed.					
EXG abcdxysp,abcdxysp	Exchange register contents; (r1)⇔(r2); r1 and r2 same size or \$00:(r1)⇒r2; r1=8-bit; r2=16-bit or (r1)⇔(r2); r1=16-bit; r2=8-bit	INH	B7 eb	P	[- - - - - - - -]
FDIV	Fractional divide; 16 by 16-bit; (D)÷(X)⇒X; remainder⇒D	INH	18 11	Offfffffff0	[- - - - - Δ Δ Δ]
IBEQ abdxysp, rel9	Increment and branch if equal to 0; (counter)+1⇒counter; if (counter)=0, then branch	REL (9-bit)	04 1b rr	PPP (branch) PPO (no branch)	[- - - - - - - -]
IBNE abdxysp, rel9	Increment and branch if not equal to 0; (counter)+1⇒counter; if (counter)≠0, then branch	REL (9-bit)	04 1b rr	PPP (branch) PPO (no branch)	[- - - - - - - -]
IDIV	Integer divide, unsigned; 16 by 16-bit; (D)÷(X)⇒X; remainder⇒D	INH	18 10	Offfffffff0	[- - - - - Δ 0 Δ]
IDIVS	Integer divide, signed; 16 by 16-bit; (D)÷(X)⇒X; remainder⇒D	INH	18 15	Offfffffff0	[- - - - - Δ Δ Δ Δ]
INC opr16a INC oprx0_xysppc INC oprx9_xysppc INC oprx16_xysppc INC [D_xysppc] INC [opr16_xysppc] INCA INCB	Increment M; (M)+1⇒M Increment A; (A)+1⇒A Increment B; (B)+1⇒B	EXT IDX IDX1 IDX2 [D,IDX] [IDX2] INH INH	72 hh ll 62 xb 62 xb ff 62 xb ee ff 62 xb 62 xb ee ff 42 52	rPwO rPw rPwO frPwP fIfrPw fIPrPw O O	[- - - - - Δ Δ Δ Δ]
INS	Increment SP; (SP)+1⇒SP; assembles as LEAS 1,SP	IDX	1B 81	Pf	[- - - - - - - -]
INX	Increment X; (X)+1⇒X	INH	08	O	[- - - - - Δ - -]
INY	Increment Y; (Y)+1⇒Y	INH	02	O	[- - - - - Δ - -]
JMP opr16a JMP oprx0_xysppc JMP oprx9_xysppc JMP oprx16_xysppc JMP [D_xysppc] JMP [opr16_xysppc]	Jump; subroutine address⇒PC	EXT IDX IDX1 IDX2 [D,IDX] [IDX2]	06 hh ll 05 xb 05 xb ff 05 xb ee ff 05 xb 05 xb ee ff	PPP PPP PPP fPPP fIfrPPP fIfrPPP	[- - - - - - - -]
JSR opr8a JSR opr16a JSR oprx0_xysppc JSR oprx9_xysppc JSR oprx16_xysppc JSR [D_xysppc] JSR [opr16_xysppc]	Jump to subroutine; (SP)-2⇒SP; RTN _H :RTN _L ⇒M _{SP} :M _{SP+1} ; subroutine address⇒PC	DIR EXT IDX IDX1 IDX2 [D,IDX] [IDX2]	17 dd 16 hh ll 15 xb 15 xb ff 15 xb ee ff 15 xb 15 xb ee ff	SPPP SPPP PPPS PPPS fPPPS fIfrPPPS fIfrPPPS	[- - - - - - - -]
LBCC rel16	Long branch if C clear; if C=0, then (PC)+4+rel⇒PC; same as LBHS	REL	18 24 qq rr	OPPP (branch) OPO (no branch)	[- - - - - - - -]



Freescale Semiconductor, Inc.

Central Processing Unit (CPU) Instruction Set Summary



Freescale Semiconductor, Inc.

Source Form	Operation	Address Mode	Machine Coding (Hex)	Access Detail	S X H I N Z V C
LBCC <i>rel16</i>	Long branch if C set; if C=1, then (PC)+4+rel⇒PC; same as LBLO	REL	18 25 qq rr	OPPP (branch) OPO (no branch)	[- - - - - - - -]
LBEQ <i>rel16</i>	Long branch if equal; if Z=1, then (PC)+4+rel⇒PC	REL	18 27 qq rr	OPPP (branch) OPO (no branch)	[- - - - - - - -]
LBGE <i>rel16</i>	Long branch if ≥ 0, signed; if N⊕V=0, then (PC)+4+rel⇒PC	REL	18 2C qq rr	OPPP (branch) OPO (no branch)	[- - - - - - - -]
LBGT <i>rel16</i>	Long branch if > 0, signed; if Z (N⊕V)=0, then (PC)+4+rel⇒PC	REL	18 2E qq rr	OPPP (branch) OPO (no branch)	[- - - - - - - -]
LBHI <i>rel16</i>	Long branch if higher, unsigned; if C Z=0, then (PC)+4+rel⇒PC	REL	18 22 qq rr	OPPP (branch) OPO (no branch)	[- - - - - - - -]
LBHS <i>rel16</i>	Long branch if higher or same, unsigned; if C=0, then (PC)+4+rel⇒PC; same as LBCC	REL	18 24 qq rr	OPPP (branch) OPO (no branch)	[- - - - - - - -]
LBLE <i>rel16</i>	Long branch if ≤ 0, signed; if Z (N⊕V)=1, then (PC)+4+rel⇒PC	REL	18 2F qq rr	OPPP (branch) OPO (no branch)	[- - - - - - - -]
LBLO <i>rel16</i>	Long branch if lower, unsigned; if C=1, then (PC)+4+rel⇒PC; same as LBCC	REL	18 25 qq rr	OPPP (branch) OPO (no branch)	[- - - - - - - -]
LBSL <i>rel16</i>	Long branch if lower or same, unsigned; if C Z=1, then (PC)+4+rel⇒PC	REL	18 23 qq rr	OPPP (branch) OPO (no branch)	[- - - - - - - -]
LBLT <i>rel16</i>	Long branch if < 0, signed; if N⊕V=1, then (PC)+4+rel⇒PC	REL	18 2D qq rr	OPPP (branch) OPO (no branch)	[- - - - - - - -]
LBMI <i>rel16</i>	Long branch if minus; if N=1, then (PC)+4+rel⇒PC	REL	18 2B qq rr	OPPP (branch) OPO (no branch)	[- - - - - - - -]
LBNE <i>rel16</i>	Long branch if not equal to 0; if Z=0, then (PC)+4+rel⇒PC	REL	18 26 qq rr	OPPP (branch) OPO (no branch)	[- - - - - - - -]
LBPL <i>rel16</i>	Long branch if plus; if N=0, then (PC)+4+rel⇒PC	REL	18 2A qq rr	OPPP (branch) OPO (no branch)	[- - - - - - - -]
LBRA <i>rel16</i>	Long branch always	REL	18 20 qq rr	OPPP	[- - - - - - - -]
LBRN <i>rel16</i>	Long branch never	REL	18 21 qq rr	OPO	[- - - - - - - -]
LBVC <i>rel16</i>	Long branch if V clear; if V=0, then (PC)+4+rel⇒PC	REL	18 28 qq rr	OPPP (branch) OPO (no branch)	[- - - - - - - -]
LBVS <i>rel16</i>	Long branch if V set; if V=1, then (PC)+4+rel⇒PC	REL	18 29 qq rr	OPPP (branch) OPO (no branch)	[- - - - - - - -]
LDAA # <i>opr8i</i> LDAA <i>opr8a</i> LDAA <i>opr16a</i> LDAA <i>opr0_xysppc</i> LDAA <i>opr9_xysppc</i> LDAA <i>opr16_xysppc</i> LDAA [D, <i>xysppc</i>] LDAA [<i>opr16_xysppc</i>]	Load A; (M)⇒A or imm⇒A	IMM DIR EXT IDX IDX1 IDX2 [D,IDX] [IDX2]	86 ii 96 dd B6 hh ll A6 xb A6 xb ff A6 xb ee ff A6 xb A6 xb ee ff	P rPf rPO rPf rPO frPP fIfrPf fIPrPf	[- - - - - Δ Δ 0 -]
LDAB # <i>opr8i</i> LDAB <i>opr8a</i> LDAB <i>opr16a</i> LDAB <i>opr0_xysppc</i> LDAB <i>opr9_xysppc</i> LDAB <i>opr16_xysppc</i> LDAB [D, <i>xysppc</i>] LDAB [<i>opr16_xysppc</i>]	Load B; (M)⇒B or imm⇒B	IMM DIR EXT IDX IDX1 IDX2 [D,IDX] [IDX2]	C6 ii D6 dd F6 hh ll E6 xb E6 xb ff E6 xb ee ff E6 xb E6 xb ee ff	P rPf rPO rPf rPO frPP fIfrPf fIPrPf	[- - - - - Δ Δ 0 -]

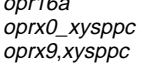

Central Processing Unit (CPU)

Freescale Semiconductor, Inc.

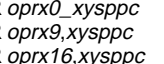
Source Form	Operation	Address Mode	Machine Coding (Hex)	Access Detail	S X H I N Z V C
LDD #opr16i LDD opr8a LDD opr16a LDD oprx0_xysppc LDD oprx9_xysppc LDD oprx16_xysppc LDD [D,xysppc] LDD [opr16,xysppc]	Load D; (M:M+1)⇒A:B or imm⇒A:B	IMM DIR EXT IDX IDX1 IDX2 [D,IDX] [IDX2]	CC jj kk DC dd FC hh ll EC xb EC xb ff EC xb ee ff EC xb EC xb ee ff	PO RPf RPO RPf RPO fRPP fI fRPf fI PRPf	[-][-][-][Δ][Δ][0][-]
LDS #opr16i LDS opr8a LDS opr16a LDS oprx0_xysppc LDS oprx9_xysppc LDS oprx16_xysppc LDS [D,xysppc] LDS [opr16,xysppc]	Load SP; (M:M+1)⇒SP or imm⇒SP	IMM DIR EXT IDX IDX1 IDX2 [D,IDX] [IDX2]	CF jj kk DF dd FF hh ll EF xb EF xb ff EF xb ee ff EF xb EF xb ee ff	PO RPf RPO RPf RPO fRPP fI fRPf fI PRPf	[-][-][-][Δ][Δ][0][-]
LDX #opr16i LDX opr8a LDX opr16a LDX oprx0_xysppc LDX oprx9_xysppc LDX oprx16_xysppc LDX [D,xysppc] LDX [opr16,xysppc]	Load X; (M:M+1)⇒X or imm⇒X	IMM DIR EXT IDX IDX1 IDX2 [D,IDX] [IDX2]	CE jj kk DE dd FE hh ll EE xb EE xb ff EE xb ee ff EE xb EE xb ee ff	PO RPf RPO RPf RPO fRPP fI fRPf fI PRPf	[-][-][-][Δ][Δ][0][-]
LDY #opr16i LDY opr8a LDY opr16a LDY oprx0_xysppc LDY oprx9_xysppc LDY oprx16_xysppc LDY [D,xysppc] LDY [opr16,xysppc]	Load Y; (M:M+1)⇒Y or imm⇒Y	IMM DIR EXT IDX IDX1 IDX2 [D,IDX] [IDX2]	CD jj kk DD dd FD hh ll ED xb ED xb ff ED xb ee ff ED xb ED xb ee ff	PO RPf RPO RPf RPO fRPP fI fRPf fI PRPf	[-][-][-][Δ][Δ][0][-]
LEAS oprx0_xysppc LEAS oprx9_xysppc LEAS oprx16_xysppc	Load effective address into SP; effective address⇒SP	IDX IDX1 IDX2	1B xb 1B xb ff 1B xb ee ff	Pf PO PP	[-][-][-][-][-][-]
LEAX oprx0_xysppc LEAX oprx9_xysppc LEAX oprx16_xysppc	Load effective address into X; effective address⇒X	IDX IDX1 IDX2	1A xb 1A xb ff 1A xb ee ff	Pf PO PP	[-][-][-][-][-][-]
LEAY oprx0_xysppc LEAY oprx9_xysppc LEAY oprx16_xysppc	Load effective address into Y; effective address⇒Y	IDX IDX1 IDX2	19 xb 19 xb ff 19 xb ee ff	Pf PO PP	[-][-][-][-][-][-]
LSL opr16a LSL oprx0_xysppc LSL oprx9_xysppc LSL oprx16_xysppc LSL [D,xysppc] LSL [opr16,xysppc] LSLA LSLB	Logical shift left M; same as ASL  Logical shift left A; same as ASLA Logical shift left B; same as ASLB	EXT IDX IDX1 IDX2 [D,IDX] [IDX2] INH INH	78 hh ll 68 xb 68 xb ff 68 xb ee ff 68 xb 68 xb ee ff 48 58	rOPw rPw rPOw fRPPw fI fRPw fI PRPw O O	[-][-][-][Δ][Δ][Δ][Δ]
LSLD	Logical shift left D; same as ASLD 	INH	59	O	[-][-][-][Δ][Δ][Δ][Δ]
LSR opr16a LSR oprx0_xysppc LSR oprx9_xysppc LSR oprx16_xysppc LSR [D,xysppc] LSR [opr16,xysppc] LSRA LSRB	Logical shift right M  Logical shift right A Logical shift right B	EXT IDX IDX1 IDX2 [D,IDX] [IDX2] INH INH	74 hh ll 64 xb 64 xb ff 64 xb ee ff 64 xb 64 xb ee ff 44 54	rPwO rPw rPwO fRPPw fI fRPw fI PRPw O O	[-][-][-][0][Δ][Δ][Δ]



Source Form	Operation	Address Mode	Machine Coding (Hex)	Access Detail	S X H I N Z V C
LSRD	Logical shift right D 	INH	49	0	---0ΔΔΔ
MAXA <i>opr0_xysppc</i> MAXA <i>opr9_xysppc</i> MAXA <i>opr16_xysppc</i> MAXA [D, <i>xysppc</i>] MAXA [<i>opr16_xysppc</i>]	Maximum in A; put larger of 2 unsigned 8-bit values in A; MAX[(A), (M)]⇒A; N, Z, V, C bits reflect result of internal compare [(A)–(M)]	IDX IDX1 IDX2 [D,IDX] [IDX2]	18 18 xb 18 18 xb ff 18 18 xbee ff 18 18 xb 18 18 xbee ff	OrPf OrPO OfrrPP OfIrrPf OfIrrPf	---ΔΔΔΔ
MAXM <i>opr0_xysppc</i> MAXM <i>opr9_xysppc</i> MAXM <i>opr16_xysppc</i> MAXM [D, <i>xysppc</i>] MAXM [<i>opr16_xysppc</i>]	Maximum in M; put larger of 2 unsigned 8-bit values in M; MAX[(A), (M)]⇒M; N, Z, V, C bits reflect result of internal compare [(A)–(M)]	IDX IDX1 IDX2 [D,IDX] [IDX2]	18 1C xb 18 1C xb ff 18 1C xbee ff 18 1C xb 18 1C xbee ff	OrPw OrPwO OfrrPwP OfIrrPw OfIrrPw	---ΔΔΔΔ
MEM	Determine grade of membership; μ (grade)⇒M _y ; (X)+4⇒X; (Y)+1⇒Y; if (A)<P1 or (A)>P2 then μ=0, else μ=MIN[((A)–P1)×S1, (P2–(A))×S2, \$FF]; (A)=current crisp input value; X points at 4-byte data describing trapezoidal membership function (P1, P2, S1, S2); Y points at fuzzy input (RAM location)	Special	01	RRfOw	---??-??-??
MINA <i>opr0_xysppc</i> MINA <i>opr9_xysppc</i> MINA <i>opr16_xysppc</i> MINA [D, <i>xysppc</i>] MINA [<i>opr16_xysppc</i>]	Minimum in A; put smaller of 2 unsigned 8-bit values in A; MIN[(A), (M)]⇒A; N, Z, V, C bits reflect result of internal compare [(A)–(M)]	IDX IDX1 IDX2 [D,IDX] [IDX2]	18 19 xb 18 19 xb ff 18 19 xbee ff 18 19 xb 18 19 xbee ff	OrPf OrPO OfrrPP OfIrrPf OfIrrPf	---ΔΔΔΔ
MINM <i>opr0_xysppc</i> MINM <i>opr9_xysppc</i> MINM <i>opr16_xysppc</i> MINM [D, <i>xysppc</i>] MINM [<i>opr16_xysppc</i>]	Minimum in N; put smaller of 2 unsigned 8-bit values in M; MIN[(A), (M)]⇒M; N, Z, V, C bits reflect result of internal compare [(A)–(M)]	IDX IDX1 IDX2 [D,IDX] [IDX2]	18 1D xb 18 1D xb ff 18 1D xbee ff 18 1D xb 18 1D xbee ff	OrPw OrPwO OfrrPwP OfIrrPw OfIrrPw	---ΔΔΔΔ
MOVB # <i>opr8, opr16a</i> MOVB # <i>opr8i, oprx0_xysppc</i> MOVB <i>opr16a, opr16a</i> MOVB <i>opr16a, oprx0_xysppc</i> MOVB <i>oprx0_xysppc, opr16a</i> MOVB <i>oprx0_xysppc, oprx0_xysppc</i>	Move byte; memory-to-memory 8-bit byte-move; (M ₁)⇒M ₂ ; first operand specifies byte to move	IMM-EXT IMM-IDX EXT-EXT EXT-EXT EXT-IDX IDX-EXT IDX-IDX	18 0B ii hh ll 18 08 xb ii 18 0C hh ll hh ll 18 09 xb hh ll 18 0D xb hh ll 18 0A xb xb	OPwP OPwO OrPwPO OPrPw OrPwP OrPwO	---ΔΔΔΔ
MOVW # <i>opr16, opr16a</i> MOVW # <i>opr16i, oprx0_xysppc</i> MOVW <i>opr16a, opr16a</i> MOVW <i>opr16a, oprx0_xysppc</i> MOVW <i>oprx0_xysppc, opr16a</i> MOVW <i>oprx0_xysppc, oprx0_xysppc</i>	Move word; memory-to-memory 16-bit word-move; (M ₁ :M ₁ +1)⇒M ₂ :M ₂ +1; first operand specifies word to move	IMM-EXT IMM-IDX EXT-EXT EXT-EXT EXT-IDX IDX-EXT IDX-IDX	18 03 jj kk hh ll 18 00 xb jj kk 18 04 hh ll hh ll 18 01 xb hh ll 18 05 xb hh ll 18 02 xb xb	OPWPO OPPw ORPwPO OPrPw ORPwP ORPwO	---ΔΔΔΔ
MUL	Multiply, unsigned, 8 by 8-bit; (A)×(B)⇒A:B	INH	12	0	---ΔΔΔΔ
NEG <i>opr16a</i> NEG <i>opr0_xysppc</i> NEG <i>opr9_xysppc</i> NEG <i>opr16_xysppc</i> NEG [D, <i>xysppc</i>] NEG [<i>opr16_xysppc</i>] NEGA NEGB	Negate M; 0–(M)⇒M or (M)+1⇒M Negate A; 0–(A)⇒A or (A)+1⇒A Negate B; 0–(B)⇒B or (B)+1⇒B	EXT IDX IDX1 IDX2 [D,IDX] [IDX2] INH INH	70 hh ll 60 xb 60 xb ff 60 xbee ff 60 xb 60 xbee ff 40 50	rPwO rPw rPwO frPwP fIrrPw fIrrPw O O	---ΔΔΔΔ
NOP	No operation	INH	A7	0	---ΔΔΔΔ

Freescale Semiconductor, Inc.







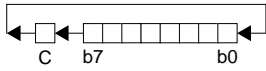
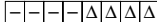
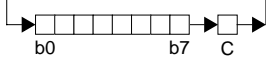
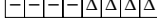
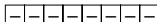

Central Processing Unit (CPU)

Freescale Semiconductor, Inc.

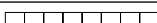
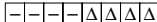
Source Form	Operation	Address Mode	Machine Coding (Hex)	Access Detail	S X H I N Z V C
ORAA #opr8i ORAA opr8a ORAA opr16a ORAA oprx0_xysppc ORAA oprx9_xysppc ORAA oprx16_xysppc ORAA [D_xysppc] ORAA [oprx16_xysppc]	OR accumulator A; (A) (M)⇒A or (A) imm⇒A	IMM DIR EXT IDX IDX1 IDX2 [D,IDX] [IDX2]	8A ii 9A dd BA hh ll AA xb AA xb ff AA xb ee ff AA xb AA xb ee ff	P rPf rPO rPf rPO frPP fIfrPf fIPrPf	[- - - - Δ Δ 0 -]
ORAB #opr8i ORAB opr8a ORAB opr16a ORAB oprx0_xysppc ORAB oprx9_xysppc ORAB oprx16_xysppc ORAB [D_xysppc] ORAB [oprx16_xysppc]	OR accumulator B; (B) (M)⇒B or (B) imm⇒B	IMM DIR EXT IDX IDX1 IDX2 [D,IDX] [IDX2]	CA ii DA dd FA hh ll EA xb EA xb ff EA xb ee ff EA xb EA xb ee ff	P rPf rPO rPf rPO frPP fIfrPf fIPrPf	[- - - - Δ Δ 0 -]
ORCC #opr8i	OR CCR; (CCR) imm⇒CCR	IMM	14 ii	P	↑ ↑ ↑ ↑ ↑ ↑ ↑ ↑
PSHA	Push A; (SP)-1⇒SP; (A)⇒M _{SP}	INH	36	Os	[- - - - - - - -]
PSHB	Push B; (SP)-1⇒SP; (B)⇒M _{SP}	INH	37	Os	[- - - - - - - -]
PSHC	Push CCR; (SP)-1⇒SP; (CCR)⇒M _{SP}	INH	39	Os	[- - - - - - - -]
PSHD	Push D; (SP)-2⇒SP; (A:B)⇒M _{SP} :M _{SP+1}	INH	3B	OS	[- - - - - - - -]
PSHX	Push X; (SP)-2⇒SP; (X _H :X _L)⇒M _{SP} :M _{SP+1}	INH	34	OS	[- - - - - - - -]
PSHY	Push Y; (SP)-2⇒SP; (Y _H :Y _L)⇒M _{SP} :M _{SP+1}	INH	35	OS	[- - - - - - - -]
PULA	Pull A; (M _{SP})⇒A; (SP)+1⇒SP	INH	32	ufo	[- - - - - - - -]
PULB	Pull B; (M _{SP})⇒B; (SP)+1⇒SP	INH	33	ufo	[- - - - - - - -]
PULC	Pull CCR; (M _{SP})⇒CCR; (SP)+1⇒SP	INH	38	ufo	Δ Δ Δ Δ Δ Δ Δ Δ
PULD	Pull D; (M _{SP} :M _{SP+1})⇒A:B; (SP)+2⇒SP	INH	3A	Ufo	[- - - - - - - -]
PULX	Pull X; (M _{SP} :M _{SP+1})⇒X _H :X _L ; (SP)+2⇒SP	INH	30	Ufo	[- - - - - - - -]
PULY	Pull Y; (M _{SP} :M _{SP+1})⇒Y _H :Y _L ; (SP)+2⇒SP	INH	31	Ufo	[- - - - - - - -]
REV	Rule evaluation, unweighted; find smallest rule input; store to rule outputs unless fuzzy output is already larger	Special	18 3A	Orf (t^tx)O* ff+Orft^***	[- - ? - ? ? Δ ?]
*The t^tx loop is executed once for each element in the rule list. The ^ denotes a check for pending interrupt requests. **These are additional cycles caused by an interrupt: ff is the exit sequence and Orft^ is the re-entry sequence.					
REVV	Rule evaluation, weighted; rule weights optional; find smallest rule input; store to rule outputs unless fuzzy output is already larger	Special	18 3B	ORf (t^Tx)O* or ORf (r^ffRf)O** ffff+ORft^**** ffff+ORfr^****	[- - ? - ? ? Δ !]
*When weighting is not enabled, the t^Tx loop is executed once for each element in the rule list. The ^ denotes a check for pending interrupt requests. **When weighting is enabled, the t^Tx loop is replaced by r^ffRf. ***These are additional cycles caused by an interrupt when weighting is not enabled: ffff is the exit sequence and ORft^ is the re-entry sequence. **** These are additional cycles caused by an interrupt when weighting is enabled: ffff is the exit sequence and ORfr^ is the re-entry sequence.					

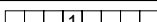
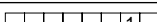
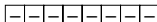

Source Form	Operation	Address Mode	Machine Coding (Hex)	Access Detail	S X H I N Z V C
ROL <i>opr16a</i> ROL <i>opr0_xysppc</i> ROL <i>opr9_xysppc</i> ROL <i>opr16_xysppc</i> ROL [D, <i>xysppc</i>] ROL [<i>opr16_xysppc</i>] ROLA ROLB	Rotate left M  Rotate left A Rotate left B	EXT IDX IDX1 IDX2 [D,IDX] [IDX2] INH INH	75 hh 11 65 xb 65 xb ff 65 xb ee ff 65 xb 65 xb ee ff 45 55	rPwO rPw rPwO frPwP fIfrPw fIPrPw O O	
ROR <i>opr16a</i> ROR <i>opr0_xysppc</i> ROR <i>opr9_xysppc</i> ROR <i>opr16_xysppc</i> ROR [D, <i>xysppc</i>] ROR [<i>opr16_xysppc</i>] RORA RORB	Rotate right M  Rotate right A Rotate right B	EXT IDX IDX1 IDX2 [D,IDX] [IDX2] INH INH	76 hh 11 66 xb 66 xb ff 66 xb ee ff 66 xb 66 xb ee ff 46 56	rPwO rPw rPwO frPwP fIfrPw fIPrPw O O	
RTC	Return from call; (M _{SP})⇒PPAGE; (SP)+1⇒SP; (M _{SP} :M _{SP+1})⇒PC _H :PC _L ; (SP)+2⇒SP	INH	0A	uUnfPPP	
RTI	Return from interrupt; (M _{SP})⇒CCR; (SP)+1⇒SP; (M _{SP} :M _{SP+1})⇒B:A; (SP)+2⇒SP; (M _{SP} :M _{SP+1})⇒X _H :X _L ; (SP)+4⇒SP; (M _{SP} :M _{SP+1})⇒PC _H :PC _L ; (SP)+2⇒SP; (M _{SP} :M _{SP+1})⇒Y _H :Y _L ; (SP)+4⇒SP	INH	0B	uUUUUPPP or uUUUUFvFPPP*	
*RTI takes 11 cycles if an interrupt is pending.					
RTS	Return from subroutine; (M _{SP} :M _{SP+1})⇒PC _H :PC _L ; (SP)+2⇒SP	INH	3D	UfPPP	
SBA	Subtract B from A; (A)-(B)⇒A	INH	18 16	OO	
SBCA # <i>opr8i</i> SBCA <i>opr8a</i> SBCA <i>opr16a</i> SBCA <i>opr0_xysppc</i> SBCA <i>opr9_xysppc</i> SBCA <i>opr16_xysppc</i> SBCA [D, <i>xysppc</i>] SBCA [<i>opr16_xysppc</i>]	Subtract with carry from A; (A)-(M)-C⇒A or (A)-imm-C⇒A	IMM DIR EXT IDX IDX1 IDX2 [D,IDX] [IDX2]	82 ii 92 dd E2 hh 11 A2 xb A2 xb ff A2 xb ee ff A2 xb A2 xb ee ff	P rPf rPO rPf rPO frPP fIfrPf fIPrPf	
SBCB # <i>opr8i</i> SBCB <i>opr8a</i> SBCB <i>opr16a</i> SBCB <i>opr0_xysppc</i> SBCB <i>opr9_xysppc</i> SBCB <i>opr16_xysppc</i> SBCB [D, <i>xysppc</i>] SBCB [<i>opr16_xysppc</i>]	Subtract with carry from B; (B)-(M)-C⇒B or (B)-imm-C⇒B	IMM DIR EXT IDX IDX1 IDX2 [D,IDX] [IDX2]	C2 ii D2 dd F2 hh 11 E2 xb E2 xb ff E2 xb ee ff E2 xb E2 xb ee ff	P rPf rPO rPf rPO frPP fIfrPf fIPrPf	
SEC	Set C; assembles as ORCC #01	IMM	14 01	P	
SEI	Set I; assembles as ORCC #10	IMM	14 10	P	
SEV	Set V; assembles as ORCC #02	IMM	14 02	P	
SEX <i>abc,dxysp</i>	Sign extend; 8-bit r1 to 16-bit r2; \$00:(r1)⇒r2 if r1 bit 7 is 0 or \$FF:(r1)⇒r2 if r1, bit 7 is 1; alternate mnemonic for TFR r1, r2	INH	B7 eb	P	



Central Processing Unit (CPU)

Freescale Semiconductor, Inc.

Source Form	Operation	Address Mode	Machine Coding (Hex)	Access Detail	S X H I N Z V C
STAA <i>opr8a</i> STAA <i>opr16a</i> STAA <i>opr0_xysppc</i> STAA <i>opr9_xysppc</i> STAA <i>opr16_xysppc</i> STAA [D, <i>xysppc</i>] STAA [<i>opr16_xysppc</i>]	Store accumulator A; (A)⇒M	DIR EXT IDX IDX1 IDX2 [D,IDX] [IDX2]	5A dd 7A hh ll 6A xb 6A xb ff 6A xb ee ff 6A xb 6A xb ee ff	Pw PwO Pw PwO PwP PIfw PIPw	[-][-][-][Δ][Δ][0][-]
STAB <i>opr8a</i> STAB <i>opr16a</i> STAB <i>opr0_xysppc</i> STAB <i>opr9_xysppc</i> STAB <i>opr16_xysppc</i> STAB [D, <i>xysppc</i>] STAB [<i>opr16_xysppc</i>]	Store accumulator B; (B)⇒M	DIR EXT IDX IDX1 IDX2 [D,IDX] [IDX2]	5B dd 7B hh ll 6B xb 6B xb ff 6B xb ee ff 6B xb 6B xb ee ff	Pw PwO Pw PwO PwP PIfw PIPw	[-][-][-][Δ][Δ][0][-]
STD <i>opr8a</i> STD <i>opr16a</i> STD <i>opr0_xysppc</i> STD <i>opr9_xysppc</i> STD <i>opr16_xysppc</i> STD [D, <i>xysppc</i>] STD [<i>opr16_xysppc</i>]	Store D; (A:B)⇒M:M+1	DIR EXT IDX IDX1 IDX2 [D,IDX] [IDX2]	5C dd 7C hh ll 6C xb 6C xb ff 6C xb ee ff 6C xb 6C xb ee ff	PW PWO PW PWO PWP PIfW PIPW	[-][-][-][Δ][Δ][0][-]
STOP	Stop processing; (SP)-2⇒SP; RTN _H :RTN _L ⇒M _{SP} :M _{SP+1} ; (SP)-2⇒SP; (Y _H :Y _L)⇒M _{SP} :M _{SP+1} ; (SP)-2⇒SP; (X _H :X _L)⇒M _{SP} :M _{SP+1} ; (SP)-2⇒SP; (B:A)⇒M _{SP} :M _{SP+1} ; (SP)-1⇒SP; (CCR)⇒M _{SP} ; stop all clocks	INH	18 3E	OOSSSSsf (enter stop mode) fVfPPP (exit stop mode) ff (continue stop mode) OO (if stop mode disabled by S=1)	[-][-][-][-][-][-]
STS <i>opr8a</i> STS <i>opr16a</i> STS <i>opr0_xysppc</i> STS <i>opr9_xysppc</i> STS <i>opr16_xysppc</i> STS [D, <i>xysppc</i>] STS [<i>opr16_xysppc</i>]	Store SP; (SP _H :SP _L)⇒M:M+1	DIR EXT IDX IDX1 IDX2 [D,IDX] [IDX2]	5F dd 7F hh ll 6F xb 6F xb ff 6F xb ee ff 6F xb 6F xb ee ff	PW PWO PW PWO PWP PIfW PIPW	[-][-][-][Δ][Δ][0][-]
STX <i>opr8a</i> STX <i>opr16a</i> STX <i>opr0_xysppc</i> STX <i>opr9_xysppc</i> STX <i>opr16_xysppc</i> STX [D, <i>xysppc</i>] STX [<i>opr16_xysppc</i>]	Store X; (X _H :X _L)⇒M:M+1	DIR EXT IDX IDX1 IDX2 [D,IDX] [IDX2]	5E dd 7E hh ll 6E xb 6E xb ff 6E xb ee ff 6E xb 6E xb ee ff	PW PWO PW PWO PWP PIfW PIPW	[-][-][-][Δ][Δ][0][-]
STY <i>opr8a</i> STY <i>opr16a</i> STY <i>opr0_xysppc</i> STY <i>opr9_xysppc</i> STY <i>opr16_xysppc</i> STY [D, <i>xysppc</i>] STY [<i>opr16_xysppc</i>]	Store Y; (Y _H :Y _L)⇒M:M+1	DIR EXT IDX IDX1 IDX2 [D,IDX] [IDX2]	5D dd 7D hh ll 6D xb 6D xb ff 6D xb ee ff 6D xb 6D xb ee ff	PW PWO PW PWO PWP PIfW PIPW	[-][-][-][Δ][Δ][0][-]
SUBA # <i>opr8i</i> SUBA <i>opr8a</i> SUBA <i>opr16a</i> SUBA <i>opr0_xysppc</i> SUBA <i>opr9_xysppc</i> SUBA <i>opr16_xysppc</i> SUBA [D, <i>xysppc</i>] SUBA [<i>opr16_xysppc</i>]	Subtract from A; (A)-(M)⇒A or (A)-imm⇒A	IMM DIR EXT IDX IDX1 IDX2 [D,IDX] [IDX2]	80 ii 90 dd B0 hh ll A0 xb A0 xb ff A0 xb ee ff A0 xb A0 xb ee ff	P rPf rPO rPF rPO frPP fIfrPf fIPrPf	[-][-][-][Δ][Δ][Δ][Δ]



Source Form	Operation	Address Mode	Machine Coding (Hex)	Access Detail	S X H I N Z V C
SUBB #opr8i SUBB opr8a SUBB opr16a SUBB oprx0_xysppc SUBB oprx9_xysppc SUBB oprx16_xysppc SUBB [D,xysppc] SUBB [oprx16,xysppc]	Subtract from B; (B)-(M)⇒B or (B)-imm⇒B	IMM DIR EXT IDX IDX1 IDX2 [D,IDX] [IDX2]	C0 ii D0 dd F0 hh ll E0 xb E0 xb ff E0 xbee ff E0 xb E0 xbee ff	P rPf rPO rPf rPO frPP fIfrPf fIPrPf	[-][-][-][Δ][Δ][Δ]
SUBD #opr16i SUBD opr8a SUBD opr16a SUBD oprx0_xysppc SUBD oprx9_xysppc SUBD oprx16_xysppc SUBD [D,xysppc] SUBD [oprx16,xysppc]	Subtract from D; (A:B)-(M:M+1)⇒A:B or (A:B)-imm⇒A:B	IMM DIR EXT IDX IDX1 IDX2 [D,IDX] [IDX2]	83 jj kk 93 dd B3 hh ll A3 xb A3 xb ff A3 xbee ff A3 xb A3 xbee ff	PO RPf RPO RPf RPO frPP fIfrPf fIPrPf	[-][-][-][Δ][Δ][Δ]
SWI	Software interrupt; (SP)-2⇒SP; RTN _H :RTN _L ⇒M _{SP} :M _{SP+1} ; (SP)-2⇒SP; (Y _H :Y _L)⇒M _{SP} :M _{SP+1} ; (SP)-2⇒SP; (X _H :X _L)⇒M _{SP} :M _{SP+1} ; (SP)-2⇒SP; (B:A)⇒M _{SP} :M _{SP+1} ; (SP)-1⇒SP; (CCR)⇒M _{SP} ; 1⇒I; (SWI vector)⇒PC	INH	3F	VSPSSPSP*	[-][-]-1[-][-]
*The CPU also uses VSPSSPSP for hardware interrupts and unimplemented opcode traps. Reset uses a variation of VFPPP.					
TAB	Transfer A to B; (A)⇒B	INH	18 0E	OO	[-][-][-][Δ][Δ]0[-]
TAP	Transfer A to CCR; (A)⇒CCR; assembled as TFR A, CCR	INH	E7 02	P	[Δ][Δ][Δ][Δ][Δ][Δ][Δ]
TBA	Transfer B to A; (B)⇒A	INH	18 0F	OO	[-][-][-][Δ][Δ]0[-]
TBEQ abdxysp,rel9	Test and branch if equal to 0; if (register)=0, then (PC)+2+rel⇒PC	REL (9-bit)	04 1b rr	PPP (branch) PPO (no branch)	[-][-][-][-][-][-]
TBL oprx0_xysppc	Table lookup and interpolate, 8-bit; (M)+(B)×((M+1)-(M))⇒A	IDX	18 3D xb	ORfffP	[-][-][-][Δ][Δ]-[Δ]
TBNE abdxysp,rel9	Test and branch if not equal to 0; if (register)≠0, then (PC)+2+rel⇒PC	REL (9-bit)	04 1b rr	PPP (branch) PPO (no branch)	[-][-][-][-][-][-]
TFR abcdxysp,abcdxysp	Transfer register to register; (r1)⇒r2; r1 and r2 same size or \$00:(r1)⇒r2; r1=8-bit; r2=16-bit or (r1 _L)⇒r2; r1=16-bit; r2=8-bit	INH	E7 eb	P or [Δ][Δ][Δ][Δ][Δ][Δ][Δ]	[-][-][-][-][-][-] or [Δ][Δ][Δ][Δ][Δ][Δ][Δ]
TPA	Transfer CCR to A; (CCR)⇒A; assembles as TFR CCR ,A	INH	E7 20	P	[-][-][-][-][-][-]
TRAP trapnum	Trap unimplemented opcode; (SP)-2⇒SP; RTN _H :RTN _L ⇒M _{SP} :M _{SP+1} ; (SP)-2⇒SP; (Y _H :Y _L)⇒M _{SP} :M _{SP+1} ; (SP)-2⇒SP; (X _H :X _L)⇒M _{SP} :M _{SP+1} ; (SP)-2⇒SP; (B:A)⇒M _{SP} :M _{SP+1} ; (SP)-1⇒SP; (CCR)⇒M _{SP} ; 1⇒I; (trap vector)⇒PC	INH	18 tn tn = \$30-\$39 or tn = \$40-\$FF	OVSPSSPSP	[-][-]-1[-][-]
TST opr16a TST oprx0_xysppc TST oprx9_xysppc TST oprx16_xysppc TST [D,xysppc] TST [oprx16,xysppc] TSTA TSTB	Test M; (M)-0 Test A; (A)-0 Test B; (B)-0	EXT IDX IDX1 IDX2 [D,IDX] [IDX2] INH INH	F7 hh ll E7 xb E7 xb ff E7 xbee ff E7 xb E7 xbee ff 97 D7	rPO rPf rPO frPP fIfrPf fIPrPf O O	[-][-][-][Δ][Δ]00



Central Processing Unit (CPU)

Freescale Semiconductor, Inc.

Source Form	Operation	Address Mode	Machine Coding (Hex)	Access Detail	S X H I N Z V C
TSX	Transfer SP to X; (SP)⇒X; assembles as TFR SP,X	INH	B7 75	P	[-][-][-][-][-][-]
TSY	Transfer SP to Y; (SP)⇒Y; assembles as TFR SP,Y	INH	B7 76	P	[-][-][-][-][-][-]
TXS	Transfer X to SP; (X)⇒SP; assembles as TFR X,SP	INH	B7 57	P	[-][-][-][-][-][-]
TYS	Transfer Y to SP; (Y)⇒SP; assembles as TFR Y,SP	INH	B7 67	P	[-][-][-][-][-][-]
WAI	Wait for interrupt; (SP)-2⇒SP; RTN _H :RTN _L ⇒M _{SP} :M _{SP+1} ; (SP)-2⇒SP; (Y _H :Y _L)⇒M _{SP} :M _{SP+1} ; (SP)-2⇒SP; (X _H :X _L)⇒M _{SP} :M _{SP+1} ; (SP)-2⇒SP; (B:A)⇒M _{SP} :M _{SP+1} ; (SP)-1⇒SP; (CCR)⇒M _{SP}	INH	3E	OSSSSsf (before interrupt) fVfPPP (after interrupt)	[-][-][-][-][-][-] or [-][-]-1-[-][-] or -1-1-[-][-]
WAV	Calculate weighted average; sum of products (SOP) and sum of weights (SOW)* $\sum_{i=1}^B S_i F_i \Rightarrow Y:D$ $\sum_{i=1}^B F_i \Rightarrow X$	Special	18 3C	Of (frr^ffff)O** SSS+UUUrr^****	[-]?-[-]?Δ??
*Initialize B, X, and Y: B=number of elements; X points at first element in S _i list; Y points at first element in F _i list. All S _i and F _i elements are 8-bit values. **The frr^ffff sequence is the loop for one iteration of SOP and SOW accumulation. The ^ denotes a check for pending interrupt requests. ***These are additional cycles caused by an interrupt: SSS is the exit sequence and UUUrr^ is the re-entry sequence. Intermediate values use six stack bytes.					
wavr*	Resume executing interrupted WAV	Special	3C	UUUrr^ffff(frr^ffff)O** SSS+UUUrr^****	[-]?-[-]?Δ??
*wavr is a pseudoinstruction that recovers intermediate results from the stack rather than initializing them to 0. **The frr^ffff sequence is the loop for one iteration of SOP and SOW recovery. The ^ denotes a check for pending interrupt requests. ***These are additional cycles caused by an interrupt: SSS is the exit sequence and UUUrr^ is the re-entry sequence.					
XGDY	Exchange D with X; (D)⇔(X); assembles as EXG D, X	INH	B7 C5	P	[-][-][-][-][-][-]
XGDY	Exchange D with Y; (D)⇔(Y); assembles as EXG D, Y	INH	B7 C6	P	[-][-][-][-][-][-]

Pinout and Signal Description

Contents

MC9S12DP256 Pin Assignments in 112-pin QFP	41
Power Supply Pins	44
Signal Descriptions	47
Port Signals	58

MC9S12DP256 Pin Assignments in 112-pin QFP

The MC9S12DP256 is available in a 112-pin low profile quad flat pack (LQFP). Most pins perform two or more functions, as described in the [Signal Descriptions](#). [Figure 3](#) shows pin assignments. In expanded narrow modes the lower byte data is multiplexed with higher byte data through pins PTA7:0.

NOTE: *The main body of this document refers to the 112-pin version of the device. Pins shown in bold on the block diagram and pinout are not available on the 80-pin version. Contact your Motorola representative for further information on the 80-pin option.*

Pinout and Signal Description

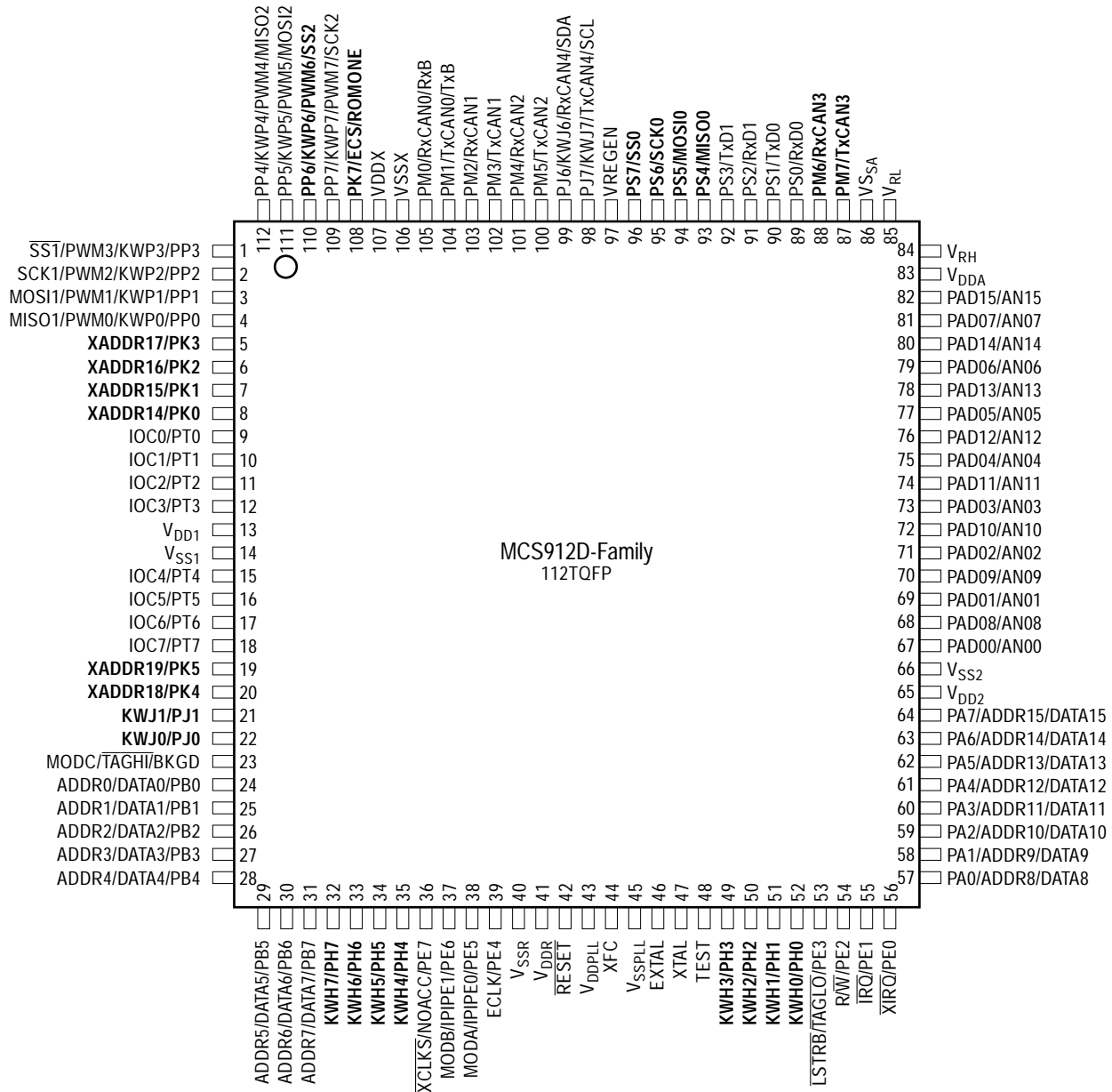

Note: This pinout is for the 112-pin version of the device.
Pins shown in bold are not available on the 80-pin version.

Figure 3 Pin Assignments in 112-pin LQFP for MC9S12DP256

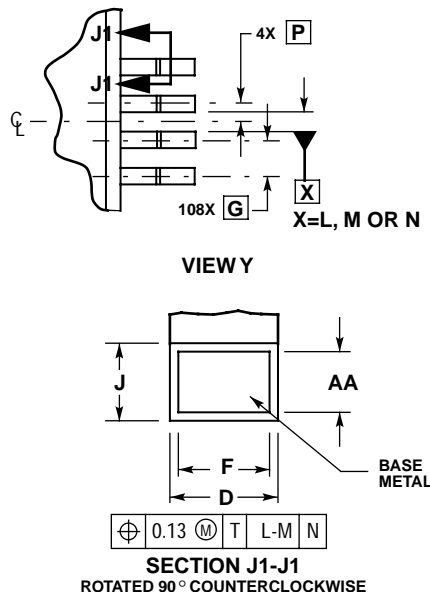
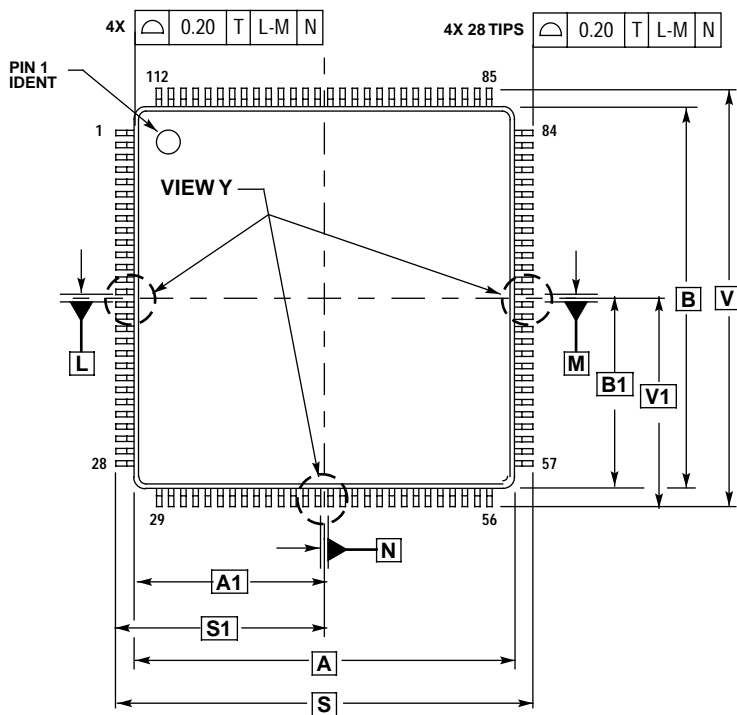

- NOTES:
1. DIMENSIONING AND TOLERANCING PER ASME Y14.5M, 1994.
 2. DIMENSIONS IN MILLIMETERS.
 3. DATUMS L, M AND N TO BE DETERMINED AT SEATING PLANE, DATUM T.
 4. DIMENSIONS S AND V TO BE DETERMINED AT SEATING PLANE, DATUM T.
 5. DIMENSIONS A AND B DO NOT INCLUDE MOLD PROTRUSION. ALLOWABLE PROTRUSION IS 0.25 PER SIDE. DIMENSIONS A AND B INCLUDE MOLD MISMATCH.
 6. DIMENSION D DOES NOT INCLUDE DAMBAR PROTRUSION. ALLOWABLE DAMBAR PROTRUSION SHALL NOT CAUSE THE D DIMENSION TO EXCEED 0.46.

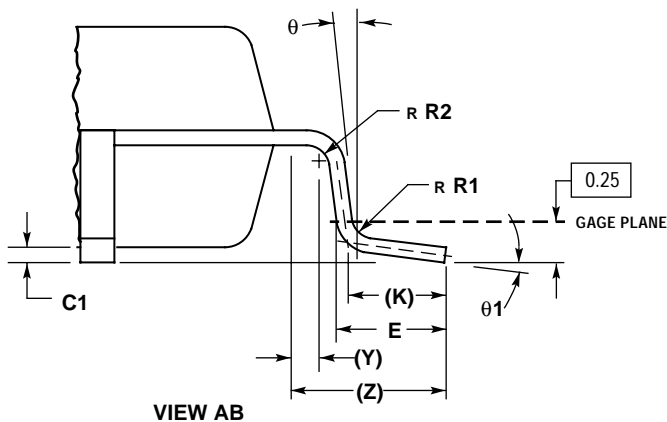
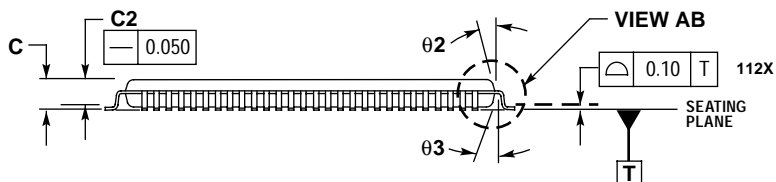

DIM	MILLIMETERS	
	MIN	MAX
A	20.000	BSC
A1	10.000	BSC
B	20.000	BSC
B1	10.000	BSC
C	--	1.600
C1	0.050	0.150
C2	1.350	1.450
D	0.270	0.370
E	0.450	0.750
F	0.270	0.330
G	0.650	BSC
J	0.090	0.170
K	0.500	REF
P	0.325	BSC
R1	0.100	0.200
R2	0.100	0.200
S	22.000	BSC
S1	11.000	BSC
V	22.000	BSC
V1	11.000	BSC
Y	0.250	REF
Z	1.000	REF
AA	0.090	0.160
theta	0°	8°
theta 1	3°	7°
theta 2	11°	13°
theta 3	11°	13°

Figure 4 112-pin QFP Mechanical Dimensions (case no. 987)

Power Supply Pins

MC9S12DP256 power and ground pins are described below and summarized in [Table 6](#).

External Power (V_{DDX}) and Ground (V_{SSX})

External power and ground for I/O drivers. Because fast signal transitions place high, short-duration current demands on the power supply, use bypass capacitors with high-frequency characteristics and place them as close to the MCU as possible. Bypass requirements depend on how heavily the MCU pins are loaded.

External Power (V_{DDR}) and Ground (V_{SSR})

External power and ground for I/O drivers and input to the internal voltage regulator. Because fast signal transitions place high, short-duration current demands on the power supply, use bypass capacitors with high-frequency characteristics and place them as close to the MCU as possible. Bypass requirements depend on how heavily the MCU pins are loaded.

Internal Power ($V_{DD1,2}$) and Ground ($V_{SS1,2}$)

Power is supplied to the MCU through V_{DD} and V_{SS} . Because fast signal transitions place high, short-duration current demands on the power supply, use bypass capacitors with high-frequency characteristics and place them as close to the MCU as possible. This 2.5V supply is derived from the internal voltage regulator. There is no static load on those pins allowed. The internal voltage regulator is turned off, if VREGEN is tied to ground.

 V_{DDA} , V_{SSA}

Provides operating voltage and ground for the analog-to-digital converters. It provides also the reference for the internal voltage regulator. This allows the supply voltage to the A/D and the reference voltage to be bypassed independently.

Analog to Digital Reference Voltages (V_{RH} , V_{RL})

Provides reference voltage and ground for the analog-to-digital converters.

- V_{DDPLL}, V_{SSPLL}** Provides operating voltage and ground for the Oscillator and the Phased-Locked Loop. This allows the supply voltage to the Oscillator and PLL to be bypassed independently. This 2.5V voltage is generated by the internal voltage regulator.
- VREGEN** Enables the internal 5V to 2.5V voltage regulator. If this pin is tied low, VDD1,2 and VDDPLL must be supplied externally.
- XFC** PLL loop filter. Please ask your Motorola representative for the interactive application note to compute PLL loop filter elements. Any current leakage on this pin must be avoided.

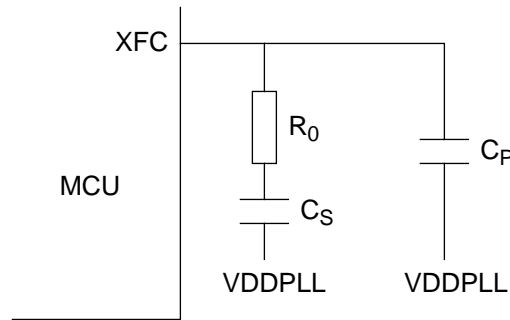

Figure 5 PLL Loop Filter Connections

Table 6 MC9S12DP256 Power and Ground Connection Summary

Mnemonic	Pin Number	Nominal Voltage	Description
	112-pin QFP		
$V_{DD1,2}$	13, 65	2.5 V	Internal power and ground generated by internal regulator
$V_{SS1,2}$	14, 66	0V	
V_{DDR}	41	5.0 V	External power and ground, supply to pin drivers and internal voltage regulator.
V_{SSR}	40	0 V	
V_{DDX}	107	5.0 V	External power and ground, supply to pin drivers.
V_{SSX}	106	0 V	
V_{DDA}	83	5.0 V	Operating voltage and ground for the analog-to-digital converters and the reference for the internal voltage regulator, allows the supply voltage to the A/D to be bypassed independently.
V_{SSA}	86	0 V	
V_{RL}	85	0 V	Reference voltages for the analog-to-digital converter.
V_{RH}	84	5.0 V	
V_{DDPLL}	43	2.5 V	Provides operating voltage and ground for the Phased-Locked Loop. This allows the supply voltage to the PLL to be bypassed independently. Internal power and ground generated by internal regulator.
V_{SSPLL}	45	0 V	
VREGEN	97	5V	Internal Voltage Regulator enable/disable

Signal Descriptions

Crystal Driver and External Clock Input (XTAL, EXTAL)

These pins provide the interface for either a crystal or a CMOS compatible clock to control the internal clock generator circuitry. Out of reset the frequency applied to EXTAL is two times the desired ECLK rate.

NOTE: *CRYSTAL CIRCUIT IS CHANGED FROM STANDARD.*

NOTE: *The internal return path for the oscillator is the VSSPLL pin. Therefore it is recommended to connect the common node of the resonator and the capacitor directly to the VSSPLL pin.*

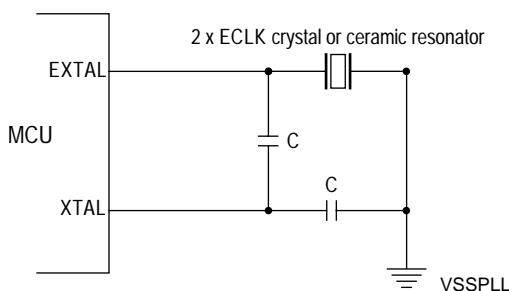

Figure 6 Common Crystal Connections

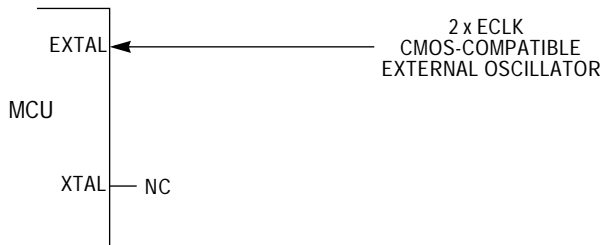

Figure 7 External Oscillator Connections

XTAL is the crystal output. The XTAL pin must be left without termination when an external CMOS compatible clock input is connected to the EXTAL pin. The maximum voltage for this input is VDDPLL. By pulling

port PE7 (\overline{XCLKS}) low during the reset phase the internal low current oscillator is bypassed and an internal buffer driven by EXTAL feeds the internal clocks. The XTAL output is normally intended to drive only a crystal. The XTAL output can be buffered with a high-impedance buffer to drive the EXTAL input of another device. The maximum output voltage of this pin is VDDPLL.

In all cases take extra care in the circuit board layout around the oscillator pins. Load capacitances in the oscillator circuits include all stray layout capacitances. Refer to [Figure 6](#) and [Figure 7](#) for diagrams of oscillator circuits.

E-Clock Output (ECLK)

ECLK is the output connection for the internal bus clock. It is used to demultiplex the address and data in expanded modes and is used as a timing reference. ECLK frequency is equal to 1/2 the crystal frequency out of reset. The ECLK pin is initially configured as ECLK output with stretch in all expanded modes. The E clock output function depends upon the settings of the NECLK bit in the PEAR register, the IVIS bit in the MODE register and the ESTR bit in the EBICTL register. All clocks, including the E clock, are halted when the MCU is in STOP mode. It is possible to configure the MCU to interface to slow external memory. ECLK can be stretched for such accesses. Reference the MISC register (EXSTR[1:0] bits) for more information. In normal expanded narrow mode, the E clock is available for use in external select decode logic or as a constant speed clock for use in the external application system.

Reset ($\overline{\text{RESET}}$)

$\overline{\text{RESET}}$ is an active low bidirectional control signal that acts as an input to initialize the MCU to a known start-up state. It also acts as an open-drain output to indicate that an internal failure has been detected in either the clock monitor or COP watchdog circuit. The MCU goes into reset asynchronously and comes out of reset synchronously. This allows the part to reach a proper reset state even if the clocks have failed, while allowing synchronized operation when starting out of reset.

It is important to use an external low-voltage reset circuit (similar to MC33464-48) to prevent corruption of RAM or EEPROM due to power transitions.

The reset sequence is initiated by any of the following events:

- Clock monitor enabled and clock monitor detects slow or stopped clock
- COP watchdog enabled and watchdog timer times out
- Power-on Reset (POR)
- User applies a low level to the $\overline{\text{RESET}}$ pin

External circuitry connected to the $\overline{\text{RESET}}$ pin should not include a large capacitance that would interfere with the ability of this signal to rise to a valid logic one within 32 ECLK cycles after the low drive is released. Upon detection of any reset, an internal circuit drives the $\overline{\text{RESET}}$ pin low and a clocked reset sequence controls when the MCU can begin normal processing.

NOTE: Entry into reset is asynchronous and does not require a clock. However, the MCU cannot sequence out of reset without a system clock.

In the case of POR or a clock monitor failure a 4096 ECLK cycle oscillator startup delay is imposed before the reset recovery sequence starts ($\overline{\text{RESET}}$ is driven low throughout this 4096 cycle delay.) The internal reset recovery sequence then drives $\overline{\text{RESET}}$ low for 64 to 65 ECLK cycles and releases the drive to allow $\overline{\text{RESET}}$ to rise. 32 ECLK cycles later this circuit samples the $\overline{\text{RESET}}$ pin to see if it has risen to a logic one level. If $\overline{\text{RESET}}$ is low at this point, the reset is assumed to be coming from an external request and the internally latched states of the COP timeout and clock monitor failure are cleared so the normal reset

vector (\$FFFE:FFFF) is taken when $\overline{\text{RESET}}$ is finally released. If $\overline{\text{RESET}}$ is high after this 32 cycle delay, the reset source is tentatively assumed to be either a COP failure or a clock monitor failure. If the internally latched state of the clock monitor fail circuit is true, processing begins by fetching the clock monitor vector (\$FFFC:FFFD). If no clock monitor failure is indicated, and the latched state of the COP timeout is true, processing begins by fetching the COP vector (\$FFFA:FFFB). If neither clock monitor fail nor COP timeout are pending, processing begins by fetching the normal reset vector (\$FFFE:FFFF).

**Maskable
Interrupt Request
($\overline{\text{IRQ}}$)**

The $\overline{\text{IRQ}}$ input provides a means of applying asynchronous interrupt requests to the MCU. Either falling edge-sensitive triggering or level-sensitive triggering is program selectable (INTCR register). $\overline{\text{IRQ}}$ is always enabled and configured to level-sensitive triggering out of reset. It can be disabled by clearing IRQEN bit (INTCR register). When the MCU is reset the $\overline{\text{IRQ}}$ function is masked in the condition code register. This pin is always an input and can always be read. There is an active pull-up on this pin while in reset and immediately out of reset. The pullup can be turned off by clearing PUPEE in the PUCR register.

**Nonmaskable
Interrupt ($\overline{\text{XIRQ}}$)**

The $\overline{\text{XIRQ}}$ input provides a means of requesting a nonmaskable interrupt after reset initialization. During reset, the X bit in the condition code register (CCR) is set and any interrupt is masked until MCU software enables it. Because the $\overline{\text{XIRQ}}$ input is level sensitive, it can be connected to a multiple-source wired-OR network. This pin is always an input and can always be read. There is an active pull-up on this pin while in reset and immediately out of reset. The pullup can be turned off by clearing PUPEE in the PUCR register. $\overline{\text{XIRQ}}$ is often used as a power loss detect interrupt.

Whenever $\overline{\text{XIRQ}}$ or $\overline{\text{IRQ}}$ are used with multiple interrupt sources, ($\overline{\text{IRQ}}$ must be configured for level-sensitive operation if there is more than one source of $\overline{\text{IRQ}}$ interrupt), each source must drive the interrupt input with an open-drain type of driver to avoid contention between outputs. There must also be an interlock mechanism at each interrupt source so that the source holds the interrupt line low until the MCU recognizes and acknowledges the interrupt request. If the interrupt line is held low, the

MCU will recognize another interrupt as soon as the interrupt mask bit in the MCU is cleared (normally upon return from an interrupt).

Mode Select (MODA, MODB, and MODC)

The state of these pins during reset determine the MCU operating mode. After reset, MODA and MODB can be configured as instruction queue tracking signals IPIPE0 and IPIPE1 in expanded modes. MODA, and MODB have active pulldowns during reset. MODC has the pull-up on the pin enabled after reset.

Single-Wire Background Mode Pin (BKGD) shared with MODC

The BKGD pin receives and transmits serial background debugging commands. A special self-timing protocol is used. Out of reset the pin is configured as input with internal pull-up enabled.

NOTE: *The resistance of the internal pull-up may be too high depending on the speed and the load to ensure proper BDM communication. In this case an additional external pull-up resistor must be provided.*

External Address and Data Buses (ADDR[15:0] and DATA[15:0])

External bus pins share functions with general-purpose I/O ports A and B. In single-chip operating modes, the pins can be used for general-purpose I/O; in expanded modes, the pins are used for the external buses.

In expanded wide mode, ports A and B are used for multiplexed 16-bit data and address buses. PA[7:0] correspond to ADDR[15:8]/DATA[15:8]; PB[7:0] correspond to ADDR[7:0]/DATA[7:0].

In expanded narrow mode, ports A and B are used for the 16-bit address bus, and an 8-bit data bus is multiplexed with the most significant half of the address bus on port A. In this mode, 16-bit data is handled as two back-to-back bus cycles, one for the high byte followed by one for the low byte. PA[7:0] correspond to ADDR[15:8] and to DATA[15:8] or DATA[7:0], depending on the bus cycle. The state of the address pins should be latched at the rising edge of E. To allow for maximum address setup time at external devices, a transparent latch should be used.

Pinout and Signal Description

- Read/Write (R/ \overline{W})** In all modes this pin can be used as a general-purpose I/O and is an input with an active pull-up out of reset. If the read/write function is required it should be enabled by setting the RDWE bit in the PEAR register. External writes will not be possible until enabled.
- Low-Byte Strobe (\overline{LSTRB})** In all modes this pin can be used as a general-purpose I/O and is an input with an active pull-up out of reset. If the strobe function is required, it should be enabled by setting the LSTRE bit in the PEAR register. This signal is used in write operations. Therefore external low byte writes will not be possible until this function is enabled. This pin is also used as \overline{TAGLO} in Special Expanded modes and is multiplexed with the \overline{LSTRB} function.
- Instruction Queue Tracking Signals (IPIPE1 and IPIPE0)** IPIPE1 (PE6) and IPIPE0 (PE5) signals are used to track the state of the internal instruction pipe. Data movement and execution state information is time-multiplexed on the two signals.
- No Access (NOACC)** The NOACC signal (available on PE[7]) is used to indicate that the current bus cycle is an unused or “free” cycle. This signal will assert anytime that the CPU is not using the bus.

NOTE: *Table 7 refers to the 112-pin version of the device. Pins shown in bold are not available on the 80-pin version. Contact your Motorola representative for further information on the 80-pin option.*

Table 7 MC9S12DP256 Signal Description Summary

Pin Function	Pin Name	Powered by	Pin Number	Description
			112-pin	
$\overline{SS1_PWM3_KWP3}$	PP3	VDDX	1	Pulse Width Modulator Channel Shared with input interrupts and SPI1 See also pins 109–112
$\overline{SCK1_PWM2_KWP2}$	PP2	VDDX	2	
$\overline{MOS1_PWM1_KWP1}$	PP1	VDDX	3	
$\overline{MISO1_PWM0_KWP0}$	PP0	VDDX	4	

Table 7 MC9S12DP256 Signal Description Summary

Pin Function	Pin Name	Powered by	Pin Number	Description
			112-pin	
XADDR17	PK3	VDDX	5	Expanded addresses
XADDR16	PK2	VDDX	6	
XADDR15	PK1	VDDX	7	
XADDR14	PK0	VDDX	8	
IOC0	PT0	VDDX	9	Capture Timer Channel
IOC1	PT1	VDDX	10	
IOC2	PT2	VDDX	11	
IOC3	PT3	VDDX	12	
	VDD1	VDD1	13	2.5V core supply
	VSS1	VSS1	14	
IOC4	PT4	VDDX	15	Capture Timer Channel
IOC5	PT5	VDDX	16	
IOC6	PT6	VDDX	17	
IOC7	PT7	VDDX	18	
XADDR19	PK5	VDDX	19	Expanded Addresses
XADDR18	PK4	VDDX	20	
KWJ1	PJ1	VDDX	21	General Purpose I/O and Interrupt
KWJ0	PJ0	VDDX	22	
MODC_TAGHI	BKGD	VDDR	23	Pseudo_open_drain communication pin for the single-wire background debug mode. At the rising edge on RESET, the state of this pin is latched into the MODC bit to set the mode. When instruction tagging is on, a 0 at the falling edge of E tags the high half of the instruction word being read into the instruction queue.
ADDR0_DATA0	PB0	VDDR	24	External bus pins share function with general-purpose I/O port B. In single chip modes, the pins can be used for general-purpose I/O. In expanded modes, the pins are used for the external address and data buses.
ADDR1_DATA1	PB1	VDDR	25	
ADDR2_DATA2	PB2	VDDR	26	
ADDR3_DATA3	PB3	VDDR	27	
ADDR4_DATA4	PB4	VDDR	28	
ADDR5_DATA5	PB5	VDDR	29	
ADDR6_DATA6	PB6	VDDR	30	
ADDR7_DATA7	PB7	VDDR	31	

Pinout and Signal Description
Table 7 MC9S12DP256 Signal Description Summary

Pin Function	Pin Name	Powered by	Pin Number	Description
			112-pin	
KWH7	PH7	VDDR	32	General Purpose I/O and Interrupt
KWH6	PH6	VDDR	33	
KWH5	PH5	VDDR	34	
KWH4	PH4	VDDR	35	
$\overline{\text{XCLKS_NOACC}}$	PE7	VDDR	36	No Access. Indicates free cycles in expanded mode. Selects also external clock or oscillator during reset. Can be used as general purpose I/O pin.
IPIPE1_MODB	PE6	VDDR	37	State of mode select pins during reset determine the initial operating mode of the MCU. After reset, MODB and MODA can be configured as instruction queue tracking signals IPIPE1 and IPIPE0 or as general-purpose I/O pins.
IPIPE0_MODA	PE5	VDDR	38	
ECLK	PE4	VDDR	39	E Clock is the output connection for the external bus clock. ECLK is used as a timing reference and for address demultiplexing.
	VSSR	VSSR	40	5V Voltage Regulator and I/O Ground
	VDDR	VDDR	41	5V Voltage Regulator and I/O Supply
$\overline{\text{RESET}}$	$\overline{\text{RESET}}$	VDDR	42	An active low bidirectional control signal, $\overline{\text{RESET}}$ acts as an input to initialize the MCU to a known start-up state, and an output when COP or clock monitor causes a reset.
	VDDPLL	–	43	2.5V PLL supply
	XFC	VDDPLL	44	External PLL Filter Capacitor
	VSSPLL	–	45	2.5V PLL ground
EXTAL	EXTAL	VDDPLL	46	Crystal driver and external clock input pins. On reset all the device clocks are derived from the EXTAL input frequency. XTAL is the crystal output.
XTAL	XTAL	VDDPLL	47	
TEST_VPP	TEST	VDDR	48	Configures the device for various test modes including. SCAN testing. Also the programming voltage input for NVMs during factory test. This pin must be tied to ground in all applications.
KWH3	PH3	VDDR	49	General Purpose I/O and Interrupt
KWH2	PH2	VDDR	50	
KWH1	PH1	VDDR	51	
KWH0	PH0	VDDR	52	

Table 7 MC9S12DP256 Signal Description Summary

Pin Function	Pin Name	Powered by	Pin Number	Description
			112-pin	
$\overline{\text{LSTRB_TAGLO}}$	PE3	VDDR	53	Low byte strobe (0 = low byte valid), in all modes this pin can be used as I/O. The low strobe function is the exclusive-NOR of A0 and the internal $\overline{\text{SZ8}}$ signal. (The $\overline{\text{SZ8}}$ internal signal indicates the size 16/8 access.) Pin function $\overline{\text{TAGLO}}$ used in instruction low byte tagging.
$\text{R}/\overline{\text{W}}$	PE2	VDDR	54	Indicates direction of data on expansion bus. Shares function with general-purpose I/O. Read/write in expanded modes.
$\overline{\text{IRQ}}$	PE1	VDDR	55	Maskable interrupt request input provides a means of applying asynchronous interrupt requests to the MCU. Either falling edge-sensitive triggering or level-sensitive triggering is program selectable (INTCR register).
$\overline{\text{XIRQ}}$	PE0	VDDR	56	The $\overline{\text{XIRQ}}$ input provides a means of requesting a nonmaskable interrupt after reset initialization. Because it is level sensitive, it can be connected to a multiple-source wired-OR network.
ADDR8_DATA8	PA0	VDDR	57	External bus pins share function with general-purpose I/O ports A. In single chip modes, the pins can be used for general-purpose I/O. In expanded modes, the pins are used for the external buses.
ADDR9_DATA9	PA1	VDDR	58	
ADDR10_DATA10	PA2	VDDR	59	
ADDR11_DATA11	PA3	VDDR	60	
ADDR12_DATA12	PA4	VDDR	61	
ADDR13_DATA13	PA5	VDDR	62	
ADDR14_DATA14	PA6	VDDR	63	
ADDR15_DATA15	PA7	VDDR	64	
	VDD2	VDD2	65	2.5V core supply and ground
	VSS2	VSS2	66	
AN00	PAD00	VDDA	67	A/D Converter 0 channel 0
AN08	PAD08	VDDA	68	A/D Converter 1 channel 0
AN01	PAD01	VDDA	69	A/D Converter 0 channel 1
AN09	PAD09	VDDA	70	A/D Converter 1 channel 1
AN02	PAD02	VDDA	71	A/D Converter 0 channel 2
AN10	PAD10	VDDA	72	A/D Converter 1 channel 2
AN03	PAD03	VDDA	73	A/D Converter 0 channel 3
AN11	PAD11	VDDA	74	A/D Converter 1 channel 3
AN04	PAD04	VDDA	75	A/D Converter 0 channel 4
AN12	PAD12	VDDA	76	A/D Converter 1 channel 4

Table 7 MC9S12DP256 Signal Description Summary

Pin Function	Pin Name	Powered by	Pin Number	Description
			112-pin	
AN05	PAD05	VDDA	77	A/D Converter 0 channel 5
AN13	PAD13	VDDA	78	A/D Converter 1 channel 5
AN06	PAD06	VDDA	79	A/D Converter 0 channel 6
AN14	PAD14	VDDA	80	A/D Converter 1 channel 6
AN07	PAD07	VDDA	81	A/D Converter 0 channel 7
AN15	PAD15	VDDA	82	A/D Converter 1 channel 7
	VDDA	–	83	5.0V supply analog to digital converter
	VRH	VDDA	84	analog to digital converter reference high
	VRL	VDDA	85	analog to digital converter reference low
	VSSA	–	86	ground analog to digital converter
TxCAN3	PM7	VDDX	87	MSCAN3 transmit pin
RxCAN3	PM6	VDDX	88	MSCAN3 receive pin
RxD0	PS0	VDDX	89	SCI0 receive pin
TxD0	PS1	VDDX	90	SCI0 transmit pin
RxD1	PS2	VDDX	91	SCI1 receive pin
TxD1	PS3	VDDX	92	SCI1 transmit pin
MISO0	PS4	VDDX	93	Master in/slave out pin for serial peripheral interface 0
MOSI1	PS5	VDDX	94	Master out/slave in pin for serial peripheral interface 0
SCK0	PS6	VDDX	95	Serial clock for serial peripheral system 0
SS0	PS7	VDDX	96	Slave select output for SPI0 master mode, input for slave mode or master mode.
VREGEN	VREGEN	VDDX	97	Internal Voltage Regulator Enable
TxCAN4_SCL_KWJ7	PJ7	VDDX	98	MSCAN4 transmit pin shared with IIC serial clock line
RxCAN4_SDA_KWJ6	PJ6	VDDX	99	MSCAN4 receive pin shared with IIC serial data line
TxCAN2	PM5	VDDX	100	MSCAN2 transmit pin
RxCAN2	PM4	VDDX	101	MSCAN2 receive pin
TxCAN1	PM3	VDDX	102	MSCAN1 transmit pin
RxCAN1	PM2	VDDX	103	MSCAN1 receive pin
TxCAN0_TxB	PM1	VDDX	104	MSCAN1 transmit pin, shared with BDLC transmit pin
RxCAN0_RxB	PM0	VDDX	105	MSCAN1 receive pin, shared with BDLC receive pin
VSSX	VSSX	–	106	5V I/O supply and Ground
VDDX	VDDX	–	107	
ECS/ROMONE	PK7	VDDX	108	Emulation Chip select/ROMONE function



Table 7 MC9S12DP256 Signal Description Summary

Pin Function	Pin Name	Powered by	Pin Number	Description
			112-pin	
KWP7_PWM7_SCK2	PP7	VDDX	109	Pulse Width Modulator Channel See also pins 1–4 Pins shared with SPI system 2
KWP6_PWM6_SS2	PP6	VDDX	110	
KWP5_PWM5_MOSI2	PP5	VDDX	111	
KWP4_PWM4_MISO2	PP4	VDDX	112	

Port Signals

The MC9S12DP256 incorporates eleven ports which are used to control and access the various device subsystems. When not used for these purposes, port pins may be used for general-purpose I/O. In addition to the pins described below, each port consists of a data register which can be read and written at any time, and, with the exception of port AD0, port AD1, and PE[1:0] a data direction register which controls the direction of each pin. After reset all general purpose I/O pins are configured as input.

Port A

Port A bits 7 through 0 are associated with address lines A15 through A8 respectively and data lines D15/D7 through D8/D0 respectively. When this port is not used for external addresses such as in single-chip mode, these pins can be used as general purpose I/O. Data Direction Register A (DDRA) determines the primary direction of each pin. DDRA also determines the source of data for a read of PORTA.

Register DDRA determines whether each port A pin is an input or output. DDRA is not in the address map during expanded and peripheral mode operation. Setting a bit in DDRA makes the corresponding bit in port A an output; clearing a bit in DDRA makes the corresponding bit in port A an input. The default reset state of DDRA is all zeroes.

This register is not in the on-chip map in expanded and peripheral modes.

Port B

Port B bits 7 through 0 are associated with address lines A7 through A0 respectively and data lines D7 through D0 respectively. When this port is not used for external addresses, such as in single-chip mode, these pins can be used as general purpose I/O. Data Direction Register B (DDRB) determines the primary direction of each pin. DDRB also determines the source of data for a read of PORTB.

Register DDRB determines whether each port B pin is an input or output. DDRB is not in the address map during expanded and peripheral mode operation. Setting a bit in DDRB makes the corresponding bit in port B

an output; clearing a bit in DDRB makes the corresponding bit in port B an input. The default reset state of DDRB is all zeroes.

This register is not in the on-chip map in expanded and peripheral modes.

Port E

Port E is associated with external bus control signals and interrupt inputs. These include mode select (PE7/NOACC/ \overline{XCLKS} , PE6/MODB/IPIPE1, PE5/MODA/IPIPE0), E clock, size (\overline{LSTRB} / \overline{TAGLO}), read / write (R/ \overline{W}), \overline{IRQ} , and \overline{XIRQ} . When the associated pin is not used for one of these specific functions, the pin can be used as general purpose I/O with the exception of \overline{IRQ} and \overline{XIRQ} . The Port E Assignment Register (PEAR) selects the function of each pin and DDRE determines whether each pin is an input or output when it is configured to be general purpose I/O. DDRE also determines the source of data for a read of PORTE.

Some of these pins have software selectable pullups (NOACC, ECLK, \overline{LSTRB} , R/ \overline{W} , \overline{IRQ} and \overline{XIRQ}). A single control bit enables the pullups for all of these pins when they are configured as inputs.

This register is not in the on-chip map in peripheral mode or in expanded modes when the EME bit is set.

Port K

This port is associated with the internal memory expansion emulation pins. When the port is not enabled to emulate the internal memory expansion, the port pins are used as general-purpose I/O. This register is not in the map in peripheral mode or in expanded modes while the EMK bit in the MODE register is set.

When inputs, these pins can be selected to be high impedance or pulled up, based upon the state of the PUPKE bit in the PUCR register.

Register DDRK determines whether each port K pin is an input or output when configured as general-purpose I/O. DDRK is not in the address map during expanded and peripheral mode operation with EMK set. Setting a bit in DDRK makes the corresponding bit in port K an output;

Pinout and Signal Description

clearing a bit in DDRK makes the corresponding bit in port K an input. The default reset state of DDRK is all zeroes.

NOTE: *The ports H, J, M, P, S, T can be configured in a very flexible way. For a full and detailed overview refer to Section [Port Integration Module](#).*

Port M for MSCAN and BDLC

There are four identical MSCAN ports and a BDLC module sharing the multiplex port M. The port pins act as general purpose I/O if MSCAN and BDLC are disabled.

ATD PORT

This port is an analog input interface to the analog-to-digital subsystem. The digital function of the ports must explicitly be enabled on per pin basis using a control register in the ADC module. When the port data registers are read, they contain the digital levels appearing on the input pins at the time of the read. Input pins with signal potentials not meeting V_{IL} or V_{IH} specifications will have an indeterminate value.

Use of any ATD port pin except ETRIG for digital input does not preclude the use of any other port pin for analog input. Note that the digital/analog multiplexing function is performed in the input pad. The port registers are connected to the input pads through tristate buffers. These buffers are only activated when the port is configured as digital pin so that analog signal potentials on the input pins will not cause the buffers to draw excess supply current.

Port S for SCI0, SCI1 and SPI0

There are two identical SCI ports. Each SCI module uses two external pins. The RxD0, RxD1 and TxD0, TxD1 pins share general purpose port SCI P[3:0]. TxD0, TxD1 are available for general-purpose I/O when it is not configured for transmitter operation. RxD0, RxD1 are available for general-purpose I/O when it is not configured for receiver operation.

The SPI0 module uses four external pins. $\overline{SS0}$, SCK0, MOSI0, and MISO0 pins share general purpose port PS[7:4].

Timer Port

The timer module has eight external pins: PT[7:0]_IOC[7:0], for input capture and output compare functions. Two of the pins are also the pulse

accumulator inputs. All eight pins are available for general-purpose I/O when not configured for timer functions.

Port P for PWM

The PWM module has a total of 8 external pins on which the pulse width modulated waveforms are output. The 8 PWM outputs are multiplexed on the PP[7:0] pins. This port is further shared with SPI 1 and 2 as well as with interrupt inputs.

Port H

Port H pins are used for interrupt inputs that can be used with pins configured as inputs or outputs. The interrupts are triggered with either the falling or the rising edge signal. An interrupt is generated if the corresponding bit is enabled. There is an individual interrupt flag for every pin.

Port J

Port J pins 0, and 1 are used for interrupt inputs that can be used with pins configured as inputs or outputs. The interrupts are triggered with either the falling or the rising edge signal. An interrupt is generated if the corresponding bit is enabled. There is an individual interrupt flag for every pin. Port J pins 7 and 6 are shared amongst the 5th CAN module and the bidirectional pins to IIC bus interface subsystem.

Table 8 MC9S12DP256 Port A, B, E, K Description Summary

Port Name	Pin Numbers	Data Direction Register	Description
	112-pin		
PE[7:0]	36 – 39 53 – 56	PE[1:0] In PE[7:2] In/Out DDRE	Mode selection, bus control signals and interrupt service request signals; or general-purpose I/O.
PB[7:0]	31 – 24	In/Out DDRB	Port A and port B pins are used for address and data in expanded modes. The port data registers are not in the address map during expanded and peripheral mode operation. When in the map, port A and port B can be read or written any time. DDRA and DDRB are not in the address map in expanded or peripheral modes.
PA[7:0]	64 – 57	In/Out DDRA	
PK[7, 5:0]	108, 19 – 20, 5 – 8	In/Out DDRK	Expanded Address bits [19:14], and emulation chip select signals or general-purpose I/O.

Pinout and Signal Description
**Port Pull-Up
Pull-Down and
Reduced Drive**

MCU ports can be configured for internal pull-up. To reduce power consumption and RFI, the pin output drivers can be configured to operate at a reduced drive level. Reduced drive causes a slight increase in transition time depending on loading and should be used only for ports which have a light loading. [Table 9](#) summarizes the port pull-up default status and controls.

Table 9 Port A, B, E, K, PAD0&1 Pull-Up, Pull-Down and Reduced Drive Summary

Port Name	Resistive Input Loads	Enable Bit			Reduced Drive Control Bit		
		Register (Address)	Bit Name	Reset State	Register (Address)	Bit Name	Reset State
Port A	Pull-up	PUCR (\$000C)	PUPA	Disabled	RDRIV (\$000D)	RDPA	Full drive
Port B	Pull-up	PUCR (\$000C)	PUPB	Disabled	RDRIV (\$000D)	RDPB	Full drive
Port E:							
PE7, PE[4:0]	Pull-up	PUCR (\$000C)	PUPE	Enabled	RDRIV (\$000D)	RDPE	Full drive
PE[6:5]	Pull-down	—	—	Enabled	RDRIV (\$000D)	RDPE	Full drive
Port K[7], Port K[5:0]	Pull-up	PUCR (\$000C)	PUPKE	Enabled	RDRIV (\$000D)	RDPK	Full drive
Port ATD0[7:0]	None	—					
Port ATD1[7:0]	None	—					

System Configuration

Contents

Introduction 63
 Modules Variabilities 63
 MCU Variabilities 64

Introduction

This section describes the variabilities of the modules that are present at the MCU level and how they are connected.

NOTE: *Needs some completion or to be removed at all.*

Modules Variabilities

MMC

Table 10 MMC Module Variable I/O Signals

Signal Name	I/O	Configuration Description	Connected to
reg_sw0	I	Register Block Size set to 1K	0
ram_sw2:0	I	RAM Memory Size set to 12K	101
eep_sw1:0	I	EEPROM Size set to 4K	10
rom_sw1:0	I	ROM Mapping Select set to 48k	10
pag_sw1:0	I	256K on-chip/768K off-chip	01

The information is also readable by the MCU at address \$1C, \$1D (MEMSIZ0 and MEMSIZ1)

MCU Variabilities

Part ID Register Assignments

The PARTID register is located in the IPBI (IP-Bus interface) at address \$__1A,\$__1B. It contains a unique part ID for each revision of the chip. [Table 11](#) contains the assigned part ID numbers.

Table 11 Assigned Part ID Numbers

Part Number	Mask Set Number	PARTID
MC9S12DP256	0K36N	0001_0010, 0101_0110
MC9S12DP256	0K79X	0000_0000, 0001_0000

The coding is as follows:

Bit 15-12: Major Family identifier

Bit 11-8 : Minor Family identifier

Bit 7-4: Major mask revision number including FAB transfers

Bit 3-0: Minor - non full - mask set revisions

Registers

Contents

Register Block 65

Register Block

The register block can be mapped to any 2K byte boundary within the first 32K byte of the standard 64K byte address space by manipulating bits REG[14:11] in the INITRG register. INITRG establishes the upper five bits of the register block's 16-bit address. The register block occupies 1K byte. Default addressing (after reset) is indicated in the table below.

Reserved Registers

The reserved registers in this register block return logic zero when read. Writes to these registers have no effect.

Registers
Table 12 MC9S12DP256 Register Map

Address	Name		Bit 7	Bit 6	Bit 5	Bit 4	Bit 3	Bit 2	Bit 1	Bit 0	Module
\$0000	PORTA	Read:	Bit 7	6	5	4	3	2	1	Bit 0	MEBI
		Write:									
\$0001	PORTB	Read:	Bit 7	6	5	4	3	2	1	Bit 0	
		Write:									
\$0002	DDRA	Read:	Bit 7	6	5	4	3	2	1	Bit 0	
		Write:									
\$0003	DDRB	Read:	Bit 7	6	5	4	3	2	1	Bit 0	
		Write:									
\$0004	Reserved	Read:	0	0	0	0	0	0	0	0	
		Write:									
\$0005	Reserved	Read:	0	0	0	0	0	0	0	0	
		Write:									
\$0006	Reserved	Read:	0	0	0	0	0	0	0	0	
		Write:									
\$0007	Reserved	Read:	0	0	0	0	0	0	0	0	
		Write:									
\$0008	PORTE	Read:	Bit 7	6	5	4	3	2	Bit 1	Bit 0	
		Write:									
\$0009	DDRE	Read:	Bit 7	6	5	4	3	Bit 2	0	0	
		Write:									
\$000A	PEAR	Read:	NOACCE	0	PIPOE	NECLK	LSTRE	RDWE	0	0	
		Write:									
\$000B	MODE	Read:	MODC	MODB	MODA	0	IVIS	0	EMK	EME	
		Write:									
\$000C	PUCR	Read:	PUPKE	0	0	PUPEE	0	0	PUPBE	PUPAE	
		Write:									
\$000D	RDRIV	Read:	RDPK	0	0	RDPE	0	0	RDPB	RDPA	
		Write:									
\$000E	EBICTL	Read:	0	0	0	0	0	0	0	ESTR	
		Write:									
\$000F	Reserved	Read:	0	0	0	0	0	0	0	0	
		Write:									
\$0010	INITRM	Read:	RAM15	RAM14	RAM13	RAM12	RAM11	0	0	RAMHAL	MMC
		Write:									
\$0011	INITRG	Read:	0	REG14	REG13	REG12	REG11	0	0	0	
		Write:									
\$0012	INITEE	Read:	EE15	EE14	EE13	EE12	0	0	0	EEON	
		Write:									
\$0013	MISC	Read:	0	0	0	0	EXSTR1	EXSTR0	ROMHM	ROMON	
		Write:									
\$0014	MTSTO	Read:	Bit 7	6	5	4	3	2	1	Bit 0	
		Write:									



\$0015	ITCR	Read:	0	0	0	WRINT	ADR3	ADR2	ADR1	ADR0	INT	
		Write:										
\$0016	ITEST	Read:	INTE	INTC	INTA	INT8	INT6	INT4	INT2	INT0		
		Write:										
\$0017	MTST1	Read:	Bit 7	6	5	4	3	2	1	Bit 0	MMC	
		Write:										
\$0018	Reserved	Read:	0	0	0	0	0	0	0	0	Peripheral	
		Write:										
\$0019	Reserved	Read:	0	0	0	0	0	0	0	0		
		Write:										
\$001A	PARTIDH	Read:	ID15	ID14	ID13	ID12	ID11	ID10	ID9	ID8		
		Write:										
\$001B	PARTIDL	Read:	ID7	ID6	ID5	ID4	ID3	ID2	ID1	ID0		
		Write:										
\$001C	MEMSIZE0	Read:	reg_sw0	0	eep_sw1	eep_sw0	0	ram_sw2	ram_sw1	ram_sw0		MMC
		Write:										
\$001D	MEMSIZE1	Read:	rom_sw1	rom_sw0	0	0	0	0	pag_sw1	pag_sw0		
		Write:										
\$001E	INTCR	Read:	IRQE	IRQEN	0	0	0	0	0	0	MEBI	
		Write:										
\$001F	HPRIO	Read:	PSEL7	PSEL6	PSEL5	PSEL4	PSEL3	PSEL2	PSEL1	0	INT	
		Write:										
\$0020	Reserved	Read:	0	0	0	0	0	0	0	0	Reserved Peripheral	
		Write:										
\$0021	Reserved	Read:	0	0	0	0	0	0	0	0		
		Write:										
\$0022	Reserved	Read:	0	0	0	0	0	0	0	0		
		Write:										
\$0023	Reserved	Read:	0	0	0	0	0	0	0	0		
		Write:										
\$0024	Reserved	Read:	0	0	0	0	0	0	0	0		
		Write:										
\$0025	Reserved	Read:	0	0	0	0	0	0	0	0		
		Write:										
\$0026	Reserved	Read:	0	0	0	0	0	0	0	0		
		Write:										
\$0027	Reserved	Read:	0	0	0	0	0	0	0	0		
		Write:	Bit 7	Bit 6	Bit 5	Bit 4	Bit 3	Bit 2	Bit 1	Bit 0		

Registers

\$0028	BKPCT0	Read:	BKEN	BKFULL	BKBDM	BKTAG	0	0	0	0	BKP
		Write:									
\$0029	BKPCT1	Read:	BKOMBH	BKOMBL	BK1MBH	BK1MBL	BK0RWE	BK0RW	BK1RWE	BK1RW	
		Write:									
\$002A	BKP0X	Read:	0	0	BK0V5	BK0V4	BK0V3	BK0V2	BK0V1	BK0V0	
		Write:									
\$002B	BKP0H	Read:	Bit 15	14	13	12	11	10	9	Bit 8	
		Write:									
\$002C	BKP0L	Read:	Bit 7	6	5	4	3	2	1	Bit 0	
		Write:									
\$002D	BKP1X	Read:	0	0	BK1V5	BK1V4	BK1V3	BK1V2	BK1V1	BK1V0	
		Write:									
\$002E	BKP1H	Read:	Bit 15	14	13	12	11	10	9	Bit 8	
		Write:									
\$002F	BKP1L	Read:	Bit 7	6	5	4	3	2	1	Bit 0	
		Write:									
\$0030	PPAGE	Read:	0	0	PIX5	PIX4	PIX3	PIX2	PIX1	PIX0	MEBI
		Write:									
\$0031	Reserved	Read:	0	0	0	0	0	0	0	0	
		Write:									
\$0032	PORTK	Read:	Bit 7	6	5	4	3	2	1	Bit 0	
		Write:									
\$0033	DDRK	Read:	Bit 7	6	5	4	3	2	1	Bit 0	
		Write:									
\$0034	SYNR	Read:	0	0	SYN5	SYN4	SYN3	SYN2	SYN1	SYN0	CRG
		Write:									
\$0035	REFDV	Read:	0	0	0	0	REFDV3	REFDV2	REFDV1	REFDV0	
		Write:									
\$0036	CTFLG	Read:	TOUT7	TOUT6	TOUT5	TOUT4	TOUT3	TOUT2	TOUT1	TOUT0	
		Write:									
\$0037	CRGFLG	Read:	RTIF	PROF	0	LOCKIF	LOCK	TRACK	SCMIF	SCM	
		Write:									
\$0038	CRGINT	Read:	RTIE	0	0	LOCKIE	0	0	SCMIE	0	
		Write:									
\$0039	CLKSEL	Read:	PLLSEL	PSTP	SYSWAI	ROAWAI	PLLWAI	CWAI	RTIWAI	COPWAI	
		Write:									
\$003A	PLLCTL	Read:	CME	PLLON	AUTO	ACQ	0	0	0	SCME	
		Write:									
\$003B	RTICTL	Read:	0	RTR6	RTR5	RTR4	RTR3	RTR2	RTR1	RTR0	
		Write:									
\$003C	COPCTL	Read:	WCOP	0	0	0	0	CR2	CR1	CR0	
		Write:									
\$003D	FORBYP	Read:	RTIBYP	COPBYP	0	PLLBYP	0	0	FCM	0	
		Write:									
\$003E	CTCTL	Read:	TCTL7	TCTL6	TCTL5	TCTL4	TCTL3	TCTL2	TCTL1	TCTL0	
		Write:									



\$003F	ARMCOP	Read:	0	0	0	0	0	0	0	CRG	
		Write:	Bit 7	6	5	4	3	2	1		Bit 0
\$0040	TIOS	Read:	IOS7	IOS6	IOS5	IOS4	IOS3	IOS2	IOS1	IOS0	Enhanced Capture Timer
		Write:									
\$0041	TCFORC	Read:	0	0	0	0	0	0	0	0	
		Write:	FOC7	FOC6	FOC5	FOC4	FOC3	FOC2	FOC1	FOC0	
\$0042	TOC7M	Read:	OC7M7	OC7M6	OC7M5	OC7M4	OC7M3	OC7M2	OC7M1	OC7M0	
		Write:									
\$0043	TOC7D	Read:	OC7D7	OC7D6	OC7D5	OC7D4	OC7D3	OC7D2	OC7D1	OC7D0	
		Write:									
\$0044	TCNT (hi)	Read:	Bit 15	14	13	12	11	10	9	Bit 8	
		Write:									
\$0045	TCNT (lo)	Read:	Bit 7	6	5	4	3	2	1	Bit 0	
		Write:									
\$0046	TSCR1	Read:	TEN	TSWAI	TSFRZ	TFFCA	0	0	0	0	
		Write:									
\$0047	TTOV	Read:	TOV7	TOV6	TOV5	TOV4	TOV3	TOV2	TOV1	TOV0	
		Write:									
\$0048	TCTL1	Read:	OM7	OL7	OM6	OL6	OM5	OL5	OM4	OL4	
		Write:									
\$0049	TCTL2	Read:	OM3	OL3	OM2	OL2	OM1	OL1	OM0	OL0	
		Write:									
\$004A	TCTL3	Read:	EDG7B	EDG7A	EDG6B	EDG6A	EDG5B	EDG5A	EDG4B	EDG4A	
		Write:									
\$004B	TCTL4	Read:	EDG3B	EDG3A	EDG2B	EDG2A	EDG1B	EDG1A	EDG0B	EDG0A	
		Write:									
\$004C	TIE	Read:	C7I	C6I	C5I	C4I	C3I	C2I	C1I	C0I	
		Write:									
\$004D	TSCR2	Read:	TOI	0	0	0	TCRE	PR2	PR1	PR0	
		Write:									
\$004E	TFLG1	Read:	C7F	C6F	C5F	C4F	C3F	C2F	C1F	C0F	
		Write:									
\$004F	TFLG2	Read:	TOF	0	0	0	0	0	0	0	
		Write:									
\$0050	TC0 (hi)	Read:	Bit 15	14	13	12	11	10	9	Bit 8	
		Write:									
\$0051	TC0 (lo)	Read:	Bit 7	6	5	4	3	2	1	Bit 0	
		Write:									
\$0052	TC1 (hi)	Read:	Bit 15	14	13	12	11	10	9	Bit 8	
		Write:									
\$0053	TC1 (lo)	Read:	Bit 7	6	5	4	3	2	1	Bit 0	
		Write:									
\$0054	TC2 (hi)	Read:	Bit 15	14	13	12	11	10	9	Bit 8	
		Write:									
\$0055	TC2 (lo)	Read:	Bit 7	6	5	4	3	2	1	Bit 0	
		Write:									



Registers

Freescale Semiconductor, Inc.

\$0056	TC3 (hi)	Read:	Bit 15	14	13	12	11	10	9	Bit 8	Enhanced Capture Timer
		Write:									
\$0057	TC3 (lo)	Read:	Bit 7	6	5	4	3	2	1	Bit 0	
		Write:									
\$0058	TC4 (hi)	Read:	Bit 15	14	13	12	11	10	9	Bit 8	
		Write:									
\$0059	TC4 (lo)	Read:	Bit 7	6	5	4	3	2	1	Bit 0	
		Write:									
\$005A	TC5 (hi)	Read:	Bit 15	14	13	12	11	10	9	Bit 8	
		Write:									
\$005B	TC5 (lo)	Read:	Bit 7	6	5	4	3	2	1	Bit 0	
		Write:									
\$005C	TC6 (hi)	Read:	Bit 15	14	13	12	11	10	9	Bit 8	
		Write:									
\$005D	TC6 (lo)	Read:	Bit 7	6	5	4	3	2	1	Bit 0	
		Write:									
\$005E	TC7 (hi)	Read:	Bit 15	14	13	12	11	10	9	Bit 8	
		Write:									
\$005F	TC7 (lo)	Read:	Bit 7	6	5	4	3	2	1	Bit 0	
		Write:									
\$0060	PACTL	Read:	0	PAEN	PAMOD	PEDGE	CLK1	CLK0	PAOVI	PAI	
		Write:									
\$0061	PAFLG	Read:	0	0	0	0	0	0	PAOVF	PAIF	
		Write:									
\$0062	PACN3 (hi)	Read:	Bit 7	6	5	4	3	2	1	Bit 0	
		Write:									
\$0063	PACN2 (lo)	Read:	Bit 7	6	5	4	3	2	1	Bit 0	
		Write:									
\$0064	PACN1 (hi)	Read:	Bit 7	6	5	4	3	2	1	Bit 0	
		Write:									
\$0065	PACN0 (lo)	Read:	Bit 7	6	5	4	3	2	1	Bit 0	
		Write:									
\$0066	MCCTL	Read:	MCZI	MODMC	RDMCL	0	FLMC	MCEN	MCPR1	MCPR0	
		Write:				ICLAT					
\$0067	MCFLG	Read:	MCZF	0	0	0	POLF3	POLF2	POLF1	POLF0	
		Write:									
\$0068	ICPAR	Read:	0	0	0	0	PA3EN	PA2EN	PA1EN	PA0EN	
		Write:									
\$0069	DLYCT	Read:	0	0	0	0	0	0	DLY1	DLY0	
		Write:									
\$006A	ICOVW	Read:	NOVW7	NOVW6	NOVW5	NOVW4	NOVW3	NOVW2	NOVW1	NOVW0	
		Write:									
\$006B	ICSYS	Read:	SH37	SH26	SH15	SH04	TFMOD	PACMX	BUFEN	LATQ	
		Write:									
\$006C	Reserved	Read:									
		Write:									



\$006D	TIMTST	Read:	0	0	0	0	0	0	TCBYP	0	Enhanced Capture Timer
		Write:									
\$006E	Reserved	Read:									
		Write:									
\$006F	Reserved	Read:									
		Write:									
\$0070	PBCTL	Read:	0	PBEN	0	0	0	0	PBOVI	0	
		Write:									
\$0071	PBFLG	Read:	0	0	0	0	0	0	PBOVF	0	
		Write:									
\$0072	PA3H	Read:	Bit 7	6	5	4	3	2	1	Bit 0	
		Write:									
\$0073	PA2H	Read:	Bit 7	6	5	4	3	2	1	Bit 0	
		Write:									
\$0074	PA1H	Read:	Bit 7	6	5	4	3	2	1	Bit 0	
		Write:									
\$0075	PA0H	Read:	Bit 7	6	5	4	3	2	1	Bit 0	
		Write:									
\$0076	MCCNT (hi)	Read:	Bit 15	14	13	12	11	10	9	Bit 8	
		Write:									
\$0077	MCCNT (lo)	Read:	Bit 7	6	5	4	3	2	1	Bit 0	
		Write:									
\$0078	TC0H (hi)	Read:	Bit 15	14	13	12	11	10	9	Bit 8	
		Write:									
\$0079	TC0H (lo)	Read:	Bit 7	6	5	4	3	2	1	Bit 0	
		Write:									
\$007A	TC1H (hi)	Read:	Bit 15	14	13	12	11	10	9	Bit 8	
		Write:									
\$007B	TC1H (lo)	Read:	Bit 7	6	5	4	3	2	1	Bit 0	
		Write:									
\$007C	TC2H (hi)	Read:	Bit 15	14	13	12	11	10	9	Bit 8	
		Write:									
\$007D	TC2H (lo)	Read:	Bit 7	6	5	4	3	2	1	Bit 0	
		Write:									
\$007E	TC3H (hi)	Read:	Bit 15	14	13	12	11	10	9	Bit 8	
		Write:									
\$007F	TC3H (lo)	Read:	Bit 7	6	5	4	3	2	1	Bit 0	
		Write:									



Registers

\$0080	ATD0CTL0	Read:	0	0	0	0	0	0	0	ATD0	
		Write:									
\$081	ATD00CTL1	Read:	0	0	0	0	0	0	0		
		Write:									
\$082	ATD0CTL2	Read:	ADPU	AFFC	AWAI	ETRIGLE	ETRIGP	ETRIG	ASCIE		ASCIF
		Write:									
\$0083	ATD0CTL3	Read:	0	S8C	S4C	S2C	S1C	FIFO	FRZ1		FRZ0
		Write:									
\$0084	ATD0CTL4	Read:	SRES8	SMP1	SMP0	PRS4	PRS3	PRS2	PRS1		PRS0
		Write:									
\$0085	ATD0CTL5	Read:	DJM	DSGN	SCAN	MULT	0	CC	CB		CA
		Write:									
\$0086	ATD0STAT0	Read:	SCF	0	ETORF	FIFOR	0	CC2	CC1		CC0
		Write:									
\$0087	ATD0STAT1	Read:	CCF7	CCF6	CCF5	CCF4	CCF3	CCF2	CCF1		CCF0
		Write:									
\$0088	ATD0TEST0	Read:	SAR9	SAR8	SAR7	SAR6	SAR5	SAR4	SAR3		SAR2
		Write:									
\$0089	ATD0TEST1	Read:	SAR1	SAR0	0	0	0	RST	0		SC
		Write:									
\$008A	Reserved	Read:	0	0	0	0	0	0	0		0
		Write:									
\$008B	Reserved	Read:	0	0	0	0	0	0	0		0
		Write:									
\$008C	Reserved	Read:	0	0	0	0	0	0	0		0
		Write:									
\$008D	ATD0DIEN	Read:	Bit 7	6	5	4	3	2	1		Bit 0
		Write:									
\$008E	Reserved	Read:	0	0	0	0	0	0	0		0
		Write:									
\$008F	PORTAD0	Read:	Bit7	6	5	4	3	2	1		BIT 0
		Write:									
\$0090	ATD0DR0H	Read:	Bit15	14	13	12	11	10	9	Bit8	
		Write:									
\$0091	ATD0DR0L	Read:	Bit7	Bit6	0	0	0	0	0	0	
		Write:									
\$0092	ATD0DR1H	Read:	Bit15	14	13	12	11	10	9	Bit8	
		Write:									
\$0093	ATD0DR1L	Read:	Bit7	Bit6	0	0	0	0	0	0	
		Write:									
\$0094	ATD0DR2H	Read:	Bit15	14	13	12	11	10	9	Bit8	
		Write:									
\$0095	ATD0DR2L	Read:	Bit7	Bit6	0	0	0	0	0	0	
		Write:									
\$0096	ATD0DR3H	Read:	Bit15	14	13	12	11	10	9	Bit8	
		Write:									



\$0097	ATD0DR3L	Read:	Bit7	Bit6	0	0	0	0	0	ATD0	
		Write:									
\$0098	ATD0DR4H	Read:	Bit15	14	13	12	11	10	9		Bit8
		Write:									
\$0099	ATD0DR4L	Read:	Bit7	Bit6	0	0	0	0	0		0
		Write:									
\$009A	ATD0DR5H	Read:	Bit15	14	13	12	11	10	9		Bit8
		Write:									
\$009B	ATD0DR5L	Read:	Bit7	Bit6	0	0	0	0	0		0
		Write:									
\$009C	ATD0DR6H	Read:	Bit15	14	13	12	11	10	9		Bit8
		Write:									
\$009D	ATD0DR6L	Read:	Bit7	Bit6	0	0	0	0	0		0
		Write:									
\$009E	ATD0DR7H	Read:	Bit15	14	13	12	11	10	9		Bit8
		Write:									
\$009F	ATD0DR7L	Read:	Bit7	Bit6	0	0	0	0	0	0	
		Write:									
\$00A0	PWME	Read:	PWME7	PWME6	PWME5	PWME4	PWME3	PWME2	PWME1	PWME0	PWM
		Write:									
\$00A1	PWMPOL	Read:	PPOL7	PPOL6	PPOL5	PPOL4	PPOL3	PPOL2	PPOL1	PPOL0	
		Write:									
\$00A2	PWMCLK	Read:	PCLK7	PCLK6	PCLK5	PCLK4	PCLK3	PCLK2	PCLK1	PCLK0	
		Write:									
\$00A3	PWMPRCLK	Read:	0	PCKB2	PCKB1	PCKB0	0	PCKA2	PCKA1	PCKA0	
		Write:									
\$00A4	PWMCAE	Read:	CAE7	CAE6	CAE5	CAE4	CAE3	CAE2	CAE1	CAE0	
		Write:									
\$00A5	PWMCTL	Read:	CON67	CON45	CON23	CON01	PSWAI	PFRZ	0	0	
		Write:									
\$00A6	PWMTST	Read:	0	0	0	0	0	0	0	0	
		Write:									
\$00A7	PWMPRSC	Read:	0	0	0	0	0	0	0	0	
		Write:									
\$00A8	PWMSCLA	Read:	Bit 7	6	5	4	3	2	1	Bit 0	
		Write:									
\$00A9	PWMSCLB	Read:	Bit 7	6	5	4	3	2	1	Bit 0	
		Write:									
\$00AA	PWMSCNTA	Read:	0	0	0	0	0	0	0	0	
		Write:									
\$00AB	PWMSCNTB	Read:	0	0	0	0	0	0	0	0	
		Write:									
\$00AC	PWMCNT0	Read:	Bit 7	6	5	4	3	2	1	Bit 0	
		Write:	0	0	0	0	0	0	0	0	
\$00AD	PWMCNT1	Read:	Bit 7	6	5	4	3	2	1	Bit 0	
		Write:	0	0	0	0	0	0	0	0	



Registers

\$00AE	PWMCNT2	Read:	Bit 7	6	5	4	3	2	1	Bit 0	PWM
		Write:	0	0	0	0	0	0	0	0	
\$00AF	PWMCNT3	Read:	Bit 7	6	5	4	3	2	1	Bit 0	
		Write:	0	0	0	0	0	0	0	0	
\$00B0	PWMCNT4	Read:	Bit 7	6	5	4	3	2	1	Bit 0	
		Write:	0	0	0	0	0	0	0	0	
\$00B1	PWMCNT5	Read:	Bit 7	6	5	4	3	2	1	Bit 0	
		Write:	0	0	0	0	0	0	0	0	
\$00B2	PWMCNT6	Read:	Bit 7	6	5	4	3	2	1	Bit 0	
		Write:	0	0	0	0	0	0	0	0	
\$00B3	PWMCNT7	Read:	Bit 7	6	5	4	3	2	1	Bit 0	
		Write:	0	0	0	0	0	0	0	0	
\$00B4	PWMPER0	Read:	Bit 7	6	5	4	3	2	1	Bit 0	
		Write:	Bit 7	6	5	4	3	2	1	Bit 0	
\$00B5	PWMPER1	Read:	Bit 7	6	5	4	3	2	1	Bit 0	
		Write:	Bit 7	6	5	4	3	2	1	Bit 0	
\$00B6	PWMPER2	Read:	Bit 7	6	5	4	3	2	1	Bit 0	
		Write:	Bit 7	6	5	4	3	2	1	Bit 0	
\$00B7	PWMPER3	Read:	Bit 7	6	5	4	3	2	1	Bit 0	
		Write:	Bit 7	6	5	4	3	2	1	Bit 0	
\$00B8	PWMPER4	Read:	Bit 7	6	5	4	3	2	1	Bit 0	
		Write:	Bit 7	6	5	4	3	2	1	Bit 0	
\$00B9	PWMPER5	Read:	Bit 7	6	5	4	3	2	1	Bit 0	
		Write:	Bit 7	6	5	4	3	2	1	Bit 0	
\$00BA	PWMPER6	Read:	Bit 7	6	5	4	3	2	1	Bit 0	
		Write:	Bit 7	6	5	4	3	2	1	Bit 0	
\$00BB	PWMPER7	Read:	Bit 7	6	5	4	3	2	1	Bit 0	
		Write:	Bit 7	6	5	4	3	2	1	Bit 0	
\$00BC	PWMDTY0	Read:	Bit 7	6	5	4	3	2	1	Bit 0	
		Write:	Bit 7	6	5	4	3	2	1	Bit 0	
\$00BD	PWMDTY1	Read:	Bit 7	6	5	4	3	2	1	Bit 0	
		Write:	Bit 7	6	5	4	3	2	1	Bit 0	
\$00BE	PWMDTY2	Read:	Bit 7	6	5	4	3	2	1	Bit 0	
		Write:	Bit 7	6	5	4	3	2	1	Bit 0	
\$00BF	PWMDTY3	Read:	Bit 7	6	5	4	3	2	1	Bit 0	
		Write:	Bit 7	6	5	4	3	2	1	Bit 0	
\$00C0	PWMDTY4	Read:	Bit 7	6	5	4	3	2	1	Bit 0	
		Write:	Bit 7	6	5	4	3	2	1	Bit 0	
\$00C1	PWMDTY5	Read:	Bit 7	6	5	4	3	2	1	Bit 0	
		Write:	Bit 7	6	5	4	3	2	1	Bit 0	
\$00C2	PWMDTY6	Read:	Bit 7	6	5	4	3	2	1	Bit 0	
		Write:	Bit 7	6	5	4	3	2	1	Bit 0	
\$00C3	PWMDTY7	Read:	Bit 7	6	5	4	3	2	1	Bit 0	
		Write:	Bit 7	6	5	4	3	2	1	Bit 0	
\$00C4	PWMSDN	Read:	PWMIF	PWMIE	PWMRST RT	PWMLVL	0	PWM7IN	PWM7INL	PWM7EN A	
		Write:									

\$00C5	Reserved	Read:	0	0	0	0	0	0	0	PWM	
		Write:									
\$00C6	Reserved	Read:	0	0	0	0	0	0	0		
		Write:									
\$00C7	Reserved	Read:	0	0	0	0	0	0	0		
		Write:									
\$00C8	SCI0BDH	Read:	0	0	0	SBR12	SBR11	SBR10	SBR9	SBR8	SCI0
		Write:									
\$00C9	SCI0BDL	Read:	SBR7	SBR6	SBR5	SBR4	SBR3	SBR2	SBR1	SBR0	
		Write:									
\$00CA	SC0CR1	Read:	LOOPS	SCISWAI	RSRC	M	WAKE	ILT	PE	PT	
		Write:									
\$00CB	SCI0CR2	Read:	TIE	TCIE	RIE	ILIE	TE	RE	RWU	SBK	
		Write:									
\$00CC	SCI0SR1	Read:	TDRE	TC	RDRF	IDLE	OR	NF	FE	PF	
		Write:									
\$00CD	SC0SR2	Read:	0	0	0	0	0	BRK13	TXDIR	RAF	
		Write:									
\$00CE	SCI0DRH	Read:	R8	T8	0	0	0	0	0	0	
		Write:									
\$00CF	SCI0DRL	Read:	R7	R6	R5	R4	R3	R2	R1	R0	
		Write:	T7	T6	T5	T4	T3	T2	T1	T0	
\$00D0	SCI1BDH	Read:	0	0	0	SBR12	SBR11	SBR10	SBR9	SBR8	
		Write:									
\$00D1	SCI1BDL	Read:	SBR7	SBR6	SBR5	SBR4	SBR3	SBR2	SBR1	SBR0	
		Write:									
\$00D2	SC1CR1	Read:	LOOPS	SCISWAI	RSRC	M	WAKE	ILT	PE	PT	
		Write:									
\$00D3	SC1CR2	Read:	TIE	TCIE	RIE	ILIE	TE	RE	RWU	SBK	
		Write:									
\$00D4	SC1SR1	Read:	TDRE	TC	RDRF	IDLE	OR	NF	FE	PF	
		Write:									
\$00D5	SC1SR2	Read:	0	0	0	0	0	BRK13	TXDIR	RAF	
		Write:									
\$00D6	SC1DRH	Read:	R8	T8	0	0	0	0	0	0	
		Write:									
\$00D7	SC1DRL	Read:	R7	R6	R5	R4	R3	R2	R1	R0	
		Write:	T7	T6	T5	T4	T3	T2	T1	T0	
\$00D8	SPI0CR1	Read:	SPIE	SPE	SPTIE	MSTR	CPOL	CPHA	SSOE	LSBFE	SPI0
		Write:									
\$00D9	SPI0CR2	Read:	0	0	0	MODFEN	BIDIROE	0	SPISWAI	SPC0	
		Write:									
\$00DA	SPI0BR	Read:	0	SPPR2	SPPR1	SPPR0	0	SPR2	SPR1	SPR0	
		Write:									
\$00DB	SPI0SR	Read:	SPIF	0	SPTF	MODF	0	0	0	0	
		Write:									

Registers

\$00DC	Reserved	Read:	0	0	0	0	0	0	0	SPI0	
		Write:									
\$00DD	SPI0DR	Read:	Bit7	6	5	4	3	2	1		Bit0
		Write:									
\$00DE	Reserved	Read:	0	0	0	0	0	0	0	IIC	
		Write:									
\$00DF	Reserved	Read:	0	0	0	0	0	0	0		
		Write:									
\$00E0	IBAD	Read:	ADR7	ADR6	ADR5	ADR4	ADR3	ADR2	ADR1	0	
		Write:									
\$00E1	IBFD	Read:	IBC7	IBC6	IBC5	IBC4	IBC3	IBC2	IBC1	IBC0	
		Write:									
\$00E2	IBCR	Read:	IBEN	IBIE	MS/SL	TX/RX	TXAK	0	0	IBSWAI	
		Write:						RSTA			
\$00E3	IBSR	Read:	TCF	IAAS	IBB	IBAL	0	SRW	IBIF	RXAK	
		Write:				0			0		
\$00E4	IICDR	Read:	D7	D6	D5	D4	D3	D2	D1	D0	
		Write:									
\$00E5	Reserved	Read:	0	0	0	0	0	0	0	0	
		Write:									
\$00E6	Reserved	Read:	0	0	0	0	0	0	0	0	
		Write:									
\$00E7	Reserved	Read:	0	0	0	0	0	0	0	0	
		Write:									
\$00E8	DLCBCR1	Read:	IMSG	CLKS	0	0	0	0	IE	WCM	
		Write:									
\$00E9	DLCBSVR	Read:	0	0	I3	I2	I1	I0	0	0	
		Write:									
\$00EA	DLCBCR2	Read:	SMRST	DLOOP	RX4XE	NBFS	TEOD	TSIFR	TMIFR1	TMIFR0	
		Write:									
\$00EB	DLCBDR	Read:	D7	D6	D5	D4	D3	D2	D1	D0	
		Write:									
\$00EC	DLCBARD	Read:	0	RXPOL	0	0	BO3	BO2	BO1	BO0	
		Write:									
\$00ED	DLCBRSR	Read:	0	0	R5	R4	R3	R2	R1	R0	
		Write:									
\$00EE	DLCSCR	Read:	0	0	0	BDLCE	0	0	0	0	
		Write:									
\$00EF	DLCBSTAT	Read:	0	0	0	0	0	0	0	IDLE	
		Write:									
\$00F0	SPI1CR1	Read:	SPIE	SPE	SPTIE	MSTR	CPOL	CPHA	SSOE	LSBFE	
		Write:									
\$00F1	SPI1CR2	Read:	0	0	0	MODFEN	BIDIROE	0	SPISWAI	SPC0	
		Write:									
\$00F2	SPI1BR	Read:	0	SPPR2	SPPR1	SPPR0	0	SPR2	SPR1	SPR0	
		Write:									

\$00F3	SPI1SR	Read:	SPIF	0	SPTEF	MODF	0	0	0	0	SPI1	
		Write:										
\$00F4	Reserved	Read:	0	0	0	0	0	0	0	0		
		Write:										
\$00F5	SPI1DR	Read:	Bit7	6	5	4	3	2	1	Bit0		
		Write:										
\$00F6	Reserved	Read:	0	0	0	0	0	0	0	0		
		Write:										
\$00F7	Reserved	Read:	0	0	0	0	0	0	0	0		
		Write:										
\$00F8	SPI2CR1	Read:	SPIE	SPE	SPTIE	MSTR	CPOL	CPHA	SSOE	LSBFE		SPI2
		Write:										
\$00F9	SPI2CR2	Read:	0	0	0	MODFEN	BIDIROE	0	SPISWAI	SPC0		
		Write:										
\$00FA	SPI2BR	Read:	0	SPPR2	SPPR1	SPPR0	0	SPR2	SPR1	SPR0		
		Write:										
\$00FB	SPI2SR	Read:	SPIF	0	SPTEF	MODF	0	0	0	0		
		Write:										
\$00FC	Reserved	Read:	0	0	0	0	0	0	0	0		
		Write:										
\$00FD	SPI2DR	Read:	Bit7	6	5	4	3	2	1	Bit0		
		Write:										
\$00FE	Reserved	Read:	0	0	0	0	0	0	0	0		
		Write:										
\$00FF	Reserved	Read:	0	0	0	0	0	0	0	0		
		Write:										
\$0100	FCLKDIV	Read:	FDIVLD		FDIV8	FDIV5	FDIV4	FDIV3	FDIV2	FDIV1	FDIV0	Flash Control
		Write:										
\$0101	FSEC	Read:	KEYEN	NV6	NV5	NV4	NV3	NV2	SEC01	SEC00		
		Write:										
\$0102	Reserved for Factory Test	Read:	0	0	0	0	0	0	0	0		
		Write:										
\$0103	FCNFG	Read:	CBEIE	CCIE	KEYACC	0	0	0	BKSEL1	BKSEL0		
		Write:										
\$0104	FPROT	Read:	FPOPEN	F	FPHDIS	FPHS1	FPHS0	FPLDIS	FPLS1	FPLS0		
		Write:										
\$0105	FSTAT	Read:	CBEIF	CCIF	PVIOL	ACCERR	0	BLANK	0	0		
		Write:										
\$0106	FCMD	Read:	0			0	0		0			
		Write:		ERASE	PROG			ERVR		MASS		
\$0107	Reserved for Factory Test	Read:	0	0	0	0	0	0	0	0		
		Write:										
\$0108	Reserved for Factory Test	Read:	0	0	0	0	0	0	0	0		
		Write:										
\$0109	Reserved for Factory Test	Read:	0	0	0	0	0	0	0	0		
		Write:										

Registers

\$010A	Reserved for Factory Test	Read:	0	0	0	0	0	0	0	Flash Control	
		Write:									
\$010B	Reserved for Factory Test	Read:	0	0	0	0	0	0	0		
		Write:									
\$010C	Reserved	Read:	0	0	0	0	0	0	0		
		Write:									
\$010D	Reserved	Read:	0	0	0	0	0	0	0		
		Write:									
\$010E	Reserved	Read:	0	0	0	0	0	0	0		
		Write:									
\$010F	Reserved	Read:	0	0	0	0	0	0	0		
		Write:									
\$0110	ECLKDIV	Read:	EDIVLD	EDIV8	EDIV5	EDIV4	EDIV3	EDIV2	EDIV1		EDIV0
		Write:									
\$0111	Reserved	Read:	0	0	0	0	0	0	0		EEPROM Control
		Write:									
\$0112	Reserved for Factory Test	Read:	0	0	0	0	0	0	0		
		Write:									
\$0113	ECNFG	Read:	CBEIE	CCIE	0	0	0	0	0		
		Write:									
\$0114	EPROT	Read:	EPOPEN	E	E	E	EPDIS	EP2	EP1	EP0	
		Write:									
\$0115	ESTAT	Read:	CBEIF	CCIF	PVIOL	ACCERR	0	BLANK	0	0	
		Write:									
\$0116	ECMD	Read:	0			0	0		0		
		Write:		ERASE	PROG			ERVR		MASS	
\$0117	Reserved for Factory Test	Read:	0	0	0	0	0	0	0		
		Write:									
\$0118	Reserved for Factory Test	Read:	0	0	0	0	0	0	0		
		Write:									
\$0119	Reserved for Factory Test	Read:	0	0	0	0	0	0	0		
		Write:									
\$011A	Reserved for Factory Test	Read:	0	0	0	0	0	0	0		
		Write:									
\$011B	Reserved for Factory Test	Read:	0	0	0	0	0	0	0		
		Write:									
\$011C	Reserved	Read:	0	0	0	0	0	0	0		
		Write:									
\$011D	Reserved	Read:	0	0	0	0	0	0	0		
		Write:									
\$011E	Reserved	Read:	0	0	0	0	0	0	0		
		Write:									
\$011F	Reserved	Read:	0	0	0	0	0	0	0		
		Write:									



\$0120	ATD1CTL0	Read:	0	0	0	0	0	0	0	ATD1	
		Write:									
\$0121	ATD1CTL1	Read:	0	0	0	0	0	0	0		
		Write:									
\$0122	ATD1CTL2	Read:	ADPU	AFFC	AWAI	ETRIGLE	ETRIGP	ETRIG	ASCIE		ASCIF
		Write:									
\$0123	ATD1CTL3	Read:	0	S8C	S4C	S2C	S1C	FIFO	FRZ1		FRZ0
		Write:									
\$0124	ATD1CTL4	Read:	SRES8	SMP1	SMP0	PRS4	PRS3	PRS2	PRS1		PRS0
		Write:									
\$0125	ATD1CTL5	Read:	DJM	DSGN	SCAN	MULT	0	CC	CB		CA
		Write:									
\$0126	ATD1STAT0	Read:	SCF	0	ETORF	FIFOR	0	CC2	CC1		CC0
		Write:									
\$0127	ATD1STAT1	Read:	CCF7	CCF6	CCF5	CCF4	CCF3	CCF2	CCF1		CCF0
		Write:									
\$0128	ATD1TEST0	Read:	SAR9	SAR8	SAR7	SAR6	SAR5	SAR4	SAR3		SAR2
		Write:									
\$0129	ATD1TEST1	Read:	SAR1	SAR0	0	0	0	RST	0		SC
		Write:									
\$012A	Reserved	Read:	0	0	0	0	0	0	0		0
		Write:									
\$012B	Reserved	Read:	0	0	0	0	0	0	0		0
		Write:									
\$012C	Reserved	Read:	0	0	0	0	0	0	0		0
		Write:									
\$012D	ATDDIEN	Read:	Bit 7	6	5	4	3	2	1		Bit 0
		Write:									
\$012E	Reserved	Read:	0	0	0	0	0	0	0		0
		Write:									
\$012F	PORTAD1	Read:	Bit7	6	5	4	3	2	1		BIT 0
		Write:									
\$0130	ATD1DR0H	Read:	Bit15	14	13	12	11	10	9		Bit8
		Write:									
\$0131	ATD1DR0L	Read:	Bit7	Bit6	0	0	0	0	0		0
		Write:									
\$0132	ATD1DR1H	Read:	Bit15	14	13	12	11	10	9	Bit8	
		Write:									
\$0133	ATD1DR1L	Read:	Bit7	Bit6	0	0	0	0	0	0	
		Write:									
\$0134	ATD1DR2H	Read:	Bit15	14	13	12	11	10	9	Bit8	
		Write:									
\$0135	ATD1DR2L	Read:	Bit7	Bit6	0	0	0	0	0	0	
		Write:									
\$0136	ATD1DR3H	Read:	Bit15	14	13	12	11	10	9	Bit8	
		Write:									

Registers

\$0137	ATD1DR3L	Read:	Bit7	Bit6	0	0	0	0	0	ATD1	
		Write:									
\$0138	ATD1DR4H	Read:	Bit15	14	13	12	11	10	9		Bit8
		Write:									
\$0139	ATD1DR4L	Read:	Bit7	Bit6	0	0	0	0	0		0
		Write:									
\$013A	ATD1DR5H	Read:	Bit15	14	13	12	11	10	9		Bit8
		Write:									
\$013B	ATD1DR5L	Read:	Bit7	Bit6	0	0	0	0	0		0
		Write:									
\$013C	ATD1DR6H	Read:	Bit15	14	13	12	11	10	9		Bit8
		Write:									
\$013D	ATD1DR6L	Read:	Bit7	Bit6	0	0	0	0	0		0
		Write:									
\$013E	ATD1DR7H	Read:	Bit15	14	13	12	11	10	9		Bit8
		Write:									
\$013F	ATD1DR7L	Read:	Bit7	Bit6	0	0	0	0	0	0	
		Write:									
\$0140	CAN0CTL0	Read:	RXFRM	RXACT	CSWAI	SYNCH	TIME	WUPE	SLPRQ	INITRQ	
		Write:									
\$0141	CAN0CTL1	Read:	CANE	CLKSRC	LOOPB	LISTEN	0	WUPM	SLPAK	INITAK	
		Write:									
\$0142	CAN0BTR0	Read:	SJW1	SJW0	BRP5	BRP4	BRP3	BRP2	BRP1	BRP0	
		Write:									
\$0143	CAN0BTR1	Read:	SAMP	TSEG22	TSEG21	TSEG20	TSEG13	TSEG12	TSEG11	TSEG10	
		Write:									
\$0144	CAN0RFLG	Read:	WUPIF	CSCIF	RSTAT1	RSTAT0	TSTAT1	TSTAT0	OVRIF	RXF	
		Write:									
\$0145	CAN0RIER	Read:	WUPIE	CSCIE	RSTATE1	RSTATE0	TSTATE1	TSTATE0	OVRIE	RXFIE	
		Write:									
\$0146	CAN0TFLG	Read:	0	0	0	0	0	TXE2	TXE1	TXE0	
		Write:									
\$0147	CAN0TIER	Read:	0	0	0	0	0	TXEIE2	TXEIE1	TXEIE0	
		Write:									
\$0148	CAN0TARQ	Read:	0	0	0	0	0	ABTRQ2	ABTRQ1	ABTRQ0	
		Write:									
\$0149	CAN0TAAK	Read:	0	0	0	0	0	ABTAK2	ABTAK1	ABTAK0	
		Write:									
\$014A	CAN0TBSEL	Read:	0	0	0	0	0	TX2	TX1	TX0	
		Write:									
\$014B	CAN0IDAC	Read:	0	0	IDAM1	IDAM0	0	IDHIT2	IDHIT1	IDHIT0	
		Write:									
\$014C	Reserved	Read:	0	0	0	0	0	0	0	0	
		Write:									
\$014D	Reserved	Read:	0	0	0	0	0	0	0	0	
		Write:									



\$014E	CAN0RXERR	Read:	RXERR7	RXERR6	RXERR5	RXERR4	RXERR3	RXERR2	RXERR1	RXERR0	CAN0
		Write:									
\$014F	CAN0TXERR	Read:	TXERR7	TXERR6	TXERR5	TXERR4	TXERR3	TXERR2	TXERR1	TXERR0	
		Write:									
\$0150	CAN0IDAR0	Read:	AC7	AC6	AC5	AC4	AC3	AC2	AC1	AC0	
		Write:									
\$0151	CAN0IDAR1	Read:	AC7	AC6	AC5	AC4	AC3	AC2	AC1	AC0	
		Write:									
\$0152	CAN0IDAR2	Read:	AC7	AC6	AC5	AC4	AC3	AC2	AC1	AC0	
		Write:									
\$0153	CAN0IDAR3	Read:	AC7	AC6	AC5	AC4	AC3	AC2	AC1	AC0	
		Write:									
\$0154	CAN0IDMR0	Read:	AM7	AM6	AM5	AM4	AM3	AM2	AM1	AM0	
		Write:									
\$0155	CAN0IDMR1	Read:	AM7	AM6	AM5	AM4	AM3	AM2	AM1	AM0	
		Write:									
\$0156	CAN0IDMR2	Read:	AM7	AM6	AM5	AM4	AM3	AM2	AM1	AM0	
		Write:									
\$0157	CAN0IDMR3	Read:	AM7	AM6	AM5	AM4	AM3	AM2	AM1	AM0	
		Write:									
\$0158	CAN0IDAR4	Read:	AC7	AC6	AC5	AC4	AC3	AC2	AC1	AC0	
		Write:									
\$0159	CAN0IDAR5	Read:	AC7	AC6	AC5	AC4	AC3	AC2	AC1	AC0	
		Write:									
\$015A	CAN0IDAR6	Read:	AC7	AC6	AC5	AC4	AC3	AC2	AC1	AC0	
		Write:									
\$015B	CAN0IDAR7	Read:	AC7	AC6	AC5	AC4	AC3	AC2	AC1	AC0	
		Write:									
\$015C	CAN0IDMR4	Read:	AM7	AM6	AM5	AM4	AM3	AM2	AM1	AM0	
		Write:									
\$015D	CAN0IDMR5	Read:	AM7	AM6	AM5	AM4	AM3	AM2	AM1	AM0	
		Write:									
\$015E	CAN0IDMR6	Read:	AM7	AM6	AM5	AM4	AM3	AM2	AM1	AM0	
		Write:									
\$015F	CAN0IDMR7	Read:	AM7	AM6	AM5	AM4	AM3	AM2	AM1	AM0	
		Write:									
\$0160 - \$016F	CAN0RXFG	Read:	FOREGROUND RECEIVE BUFFER								
		Write:									
\$0170 - \$017F	CAN0TXFG	Read:	FOREGROUND TRANSMIT BUFFER								
		Write:									
\$0180	CAN1CTL0	Read:	RXFRM	RXACT	CSWAI	SYNCH	TIME	WUPE	SLPRQ	INITRQ	CAN1
		Write:									
\$0181	CAN1CTL1	Read:	CANE	CLKSRC	LOOPB	LISTEN	0	WUPM	SLPAK	INITAK	
		Write:									
\$0182	CAN1BTR0	Read:	SJW1	SJW0	BRP5	BRP4	BRP3	BRP2	BRP1	BRP0	
		Write:									

Registers

\$0183	CAN1BTR1	Read:	SAMP	TSEG22	TSEG21	TSEG20	TSEG13	TSEG12	TSEG11	TSEG10	CAN1
\$0184	CAN1RFLG	Read:	WUPIF	CSCIF	RSTAT1	RSTAT0	TSTAT1	TSTAT0	OVRIF	RXF	
\$0185	CAN1RIER	Write:									
		Read:	WUPIE	CSCIE	RSTATE1	RSTATE0	TSTATE1	TSTATE0	OVRIE	RXFIE	
\$0186	CAN1TFLG	Write:									
		Read:	0	0	0	0	0	TXE2	TXE1	TXE0	
\$0187	CAN1TIER	Write:									
		Read:	0	0	0	0	0	TXEIE2	TXEIE1	TXEIE0	
\$0188	CAN1TARQ	Write:									
		Read:	0	0	0	0	0	ABTRQ2	ABTRQ1	ABTRQ0	
\$0189	CAN1TAAK	Write:									
		Read:	0	0	0	0	0	ABTAK2	ABTAK1	ABTAK0	
\$018A	CAN1TBSEL	Write:									
		Read:	0	0	0	0	0	TX2	TX1	TX0	
\$018B	CAN1IDAC	Write:									
		Read:	0	0	IDAM1	IDAM0	0	IDHIT2	IDHIT1	IDHIT0	
\$018C	Reserved	Write:									
		Read:	0	0	0	0	0	0	0	0	
\$018D	Reserved	Write:									
		Read:	0	0	0	0	0	0	0	0	
\$018E	CAN1RXERR	Write:									
		Read:	RXERR7	RXERR6	RXERR5	RXERR4	RXERR3	RXERR2	RXERR1	RXERR0	
\$018F	CAN1TXERR	Write:									
		Read:	TXERR7	TXERR6	TXERR5	TXERR4	TXERR3	TXERR2	TXERR1	TXERR0	
\$0190	CAN1IDAR0	Write:									
		Read:	AC7	AC6	AC5	AC4	AC3	AC2	AC1	AC0	
\$0191	CAN1IDAR1	Write:									
		Read:	AC7	AC6	AC5	AC4	AC3	AC2	AC1	AC0	
\$0192	CAN1IDAR2	Write:									
		Read:	AC7	AC6	AC5	AC4	AC3	AC2	AC1	AC0	
\$0193	CAN1IDAR3	Write:									
		Read:	AC7	AC6	AC5	AC4	AC3	AC2	AC1	AC0	
\$0194	CAN1IDMR0	Write:									
		Read:	AM7	AM6	AM5	AM4	AM3	AM2	AM1	AM0	
\$0195	CAN1IDMR1	Write:									
		Read:	AM7	AM6	AM5	AM4	AM3	AM2	AM1	AM0	
\$0196	CAN1IDMR2	Write:									
		Read:	AM7	AM6	AM5	AM4	AM3	AM2	AM1	AM0	
\$0197	CAN1IDMR3	Write:									
		Read:	AM7	AM6	AM5	AM4	AM3	AM2	AM1	AM0	
\$0198	CAN1IDAR4	Write:									
		Read:	AC7	AC6	AC5	AC4	AC3	AC2	AC1	AC0	
\$0199	CAN1IDAR5	Write:									
		Read:	AC7	AC6	AC5	AC4	AC3	AC2	AC1	AC0	



\$019A	CAN1IDAR6	Read: Write:	AC7	AC6	AC5	AC4	AC3	AC2	AC1	AC0	CAN1
\$019B	CAN1IDAR7	Read: Write:	AC7	AC6	AC5	AC4	AC3	AC2	AC1	AC0	
\$019C	CAN1IDMR4	Read: Write:	AM7	AM6	AM5	AM4	AM3	AM2	AM1	AM0	
\$019D	CAN1IDMR5	Read: Write:	AM7	AM6	AM5	AM4	AM3	AM2	AM1	AM0	
\$019E	CAN1IDMR6	Read: Write:	AM7	AM6	AM5	AM4	AM3	AM2	AM1	AM0	
\$019F	CAN1IDMR7	Read: Write:	AM7	AM6	AM5	AM4	AM3	AM2	AM1	AM0	
\$01A0 - \$01AF	CAN1RXFG	Read: Write:	FOREGROUND RECEIVE BUFFER								
\$01B0 - \$01BF	CAN1TXFG	Read: Write:	FOREGROUND TRANSMIT BUFFER								
\$01C0	CAN2CTL0	Read: Write:	RXFRM	RXACT	CSWAI	SYNCH	TIME	WUPE	SLPRQ	INITRQ	CAN2
\$01C1	CAN2CTL1	Read: Write:	CANE	CLKSRC	LOOPB	LISTEN	0	WUPM	SLPAK	INITAK	
\$01C2	CAN2BTR0	Read: Write:	SJW1	SJW0	BRP5	BRP4	BRP3	BRP2	BRP1	BRP0	
\$01C3	CAN2BTR1	Read: Write:	SAMP	TSEG22	TSEG21	TSEG20	TSEG13	TSEG12	TSEG11	TSEG10	
\$01C4	CAN2RFLG	Read: Write:	WUPIF	CSCIF	RSTAT1	RSTAT0	TSTAT1	TSTAT0	OVRIFF	RXF	
\$01C5	CAN2RIER	Read: Write:	WUPIE	CSCIE	RSTATE1	RSTATE0	TSTATE1	TSTATE0	OVRIE	RXFIE	
\$01C6	CAN2TFLG	Read: Write:	0	0	0	0	0	TXE2	TXE1	TXE0	
\$01C7	CAN2TIER	Read: Write:	0	0	0	0	0	TXEIE2	TXEIE1	TXEIE0	
\$01C8	CAN2TARQ	Read: Write:	0	0	0	0	0	ABTRQ2	ABTRQ1	ABTRQ0	
\$01C9	CAN2TAAK	Read: Write:	0	0	0	0	0	ABTAK2	ABTAK1	ABTAK0	
\$01CA	CAN2TBSEL	Read: Write:	0	0	0	0	0	TX2	TX1	TX0	
\$01CB	CAN2IDAC	Read: Write:	0	0	IDAM1	IDAM0	0	IDHIT2	IDHIT1	IDHIT0	
\$01CC	Reserved	Read: Write:	0	0	0	0	0	0	0	0	
\$01CD	Reserved	Read: Write:	0	0	0	0	0	0	0	0	
\$01CE	CAN2RXERR	Read: Write:	RXERR7	RXERR6	RXERR5	RXERR4	RXERR3	RXERR2	RXERR1	RXERR0	



Registers

Freescale Semiconductor, Inc.

\$01CF	CAN2TXERR	Read:	TXERR7	TXERR6	TXERR5	TXERR4	TXERR3	TXERR2	TXERR1	TXERR0	CAN2
		Write:									
\$01D0	CAN2IDAR0	Read:	AC7	AC6	AC5	AC4	AC3	AC2	AC1	AC0	
		Write:									
\$01D1	CAN2IDAR1	Read:	AC7	AC6	AC5	AC4	AC3	AC2	AC1	AC0	
		Write:									
\$01D2	CAN2IDAR2	Read:	AC7	AC6	AC5	AC4	AC3	AC2	AC1	AC0	
		Write:									
\$01D3	CAN2IDAR3	Read:	AC7	AC6	AC5	AC4	AC3	AC2	AC1	AC0	
		Write:									
\$01D4	CAN2IDMR0	Read:	AM7	AM6	AM5	AM4	AM3	AM2	AM1	AM0	
		Write:									
\$01D5	CAN2IDMR1	Read:	AM7	AM6	AM5	AM4	AM3	AM2	AM1	AM0	
		Write:									
\$01D6	CAN2IDMR2	Read:	AM7	AM6	AM5	AM4	AM3	AM2	AM1	AM0	
		Write:									
\$01D7	CAN2IDMR3	Read:	AM7	AM6	AM5	AM4	AM3	AM2	AM1	AM0	
		Write:									
\$01D8	CAN2IDAR4	Read:	AC7	AC6	AC5	AC4	AC3	AC2	AC1	AC0	
		Write:									
\$01D9	CAN2IDAR5	Read:	AC7	AC6	AC5	AC4	AC3	AC2	AC1	AC0	
		Write:									
\$01DA	CAN2IDAR6	Read:	AC7	AC6	AC5	AC4	AC3	AC2	AC1	AC0	
		Write:									
\$01DB	CAN2IDAR7	Read:	AC7	AC6	AC5	AC4	AC3	AC2	AC1	AC0	
		Write:									
\$01DC	CAN2IDMR4	Read:	AM7	AM6	AM5	AM4	AM3	AM2	AM1	AM0	
		Write:									
\$01DD	CAN2IDMR5	Read:	AM7	AM6	AM5	AM4	AM3	AM2	AM1	AM0	
		Write:									
\$01DE	CAN2IDMR6	Read:	AM7	AM6	AM5	AM4	AM3	AM2	AM1	AM0	
		Write:									
\$01DF	CAN2IDMR7	Read:	AM7	AM6	AM5	AM4	AM3	AM2	AM1	AM0	
		Write:									
\$01E0 - \$01EF	CAN2RXFG	Read:	FOREGROUND RECEIVE BUFFER								
		Write:									
\$01F0 - \$01FF	CAN2TXFG	Read:	FOREGROUND TRANSMIT BUFFER								
		Write:									
\$0200	CAN3CTL0	Read:	RXFRM	RXACT	CSWAI	SYNCH	TIME	WUPE	SLPRQ	INITRQ	CAN3
		Write:									
\$0201	CAN3CTL1	Read:	CANE	CLKSRC	LOOPB	LISTEN	0	WUPM	SLPAK	INITAK	
		Write:									
\$0202	CAN3BTR0	Read:	SJW1	SJW0	BRP5	BRP4	BRP3	BRP2	BRP1	BRP0	
		Write:									
\$0203	CAN3BTR1	Read:	SAMP	TSEG22	TSEG21	TSEG20	TSEG13	TSEG12	TSEG11	TSEG10	
		Write:									



\$0204	CAN3RFLG	Read:	WUPIF	CSCIF	RSTAT1	RSTAT0	TSTAT1	TSTAT0	OVRIF	RXF	CAN3
		Write:									
\$0205	CAN3RIER	Read:	WUPIE	CSCIE	RSTATE1	RSTATE0	TSTATE1	TSTATE0	OVRIE	RXFIE	
		Write:									
\$0206	CAN3TFLG	Read:	0	0	0	0	0	TXE2	TXE1	TXE0	
		Write:									
\$0207	CAN3TIER	Read:	0	0	0	0	0	TXEIE2	TXEIE1	TXEIE0	
		Write:									
\$0208	CAN3TARQ	Read:	0	0	0	0	0	ABTRQ2	ABTRQ1	ABTRQ0	
		Write:									
\$0209	CAN3TAAK	Read:	0	0	0	0	0	ABTAK2	ABTAK1	ABTAK0	
		Write:									
\$020A	CAN3TBSEL	Read:	0	0	0	0	0	TX2	TX1	TX0	
		Write:									
\$020B	CAN3IDAC	Read:	0	0	IDAM1	IDAM0	0	IDHIT2	IDHIT1	IDHIT0	
		Write:									
\$020C	Reserved	Read:	0	0	0	0	0	0	0	0	
		Write:									
\$020D	Reserved	Read:	0	0	0	0	0	0	0	0	
		Write:									
\$020E	CAN3RXERR	Read:	RXERR7	RXERR6	RXERR5	RXERR4	RXERR3	RXERR2	RXERR1	RXERR0	
		Write:									
\$020F	CAN3TXERR	Read:	TXERR7	TXERR6	TXERR5	TXERR4	TXERR3	TXERR2	TXERR1	TXERR0	
		Write:									
\$0210	CAN3IDAR0	Read:	AC7	AC6	AC5	AC4	AC3	AC2	AC1	AC0	
		Write:									
\$0211	CAN3IDAR1	Read:	AC7	AC6	AC5	AC4	AC3	AC2	AC1	AC0	
		Write:									
\$0212	CAN3IDAR2	Read:	AC7	AC6	AC5	AC4	AC3	AC2	AC1	AC0	
		Write:									
\$0213	CAN3IDAR3	Read:	AC7	AC6	AC5	AC4	AC3	AC2	AC1	AC0	
		Write:									
\$0214	CAN3IDMR0	Read:	AM7	AM6	AM5	AM4	AM3	AM2	AM1	AM0	
		Write:									
\$0215	CAN3IDMR1	Read:	AM7	AM6	AM5	AM4	AM3	AM2	AM1	AM0	
		Write:									
\$0216	CAN3IDMR2	Read:	AM7	AM6	AM5	AM4	AM3	AM2	AM1	AM0	
		Write:									
\$0217	CAN3IDMR3	Read:	AM7	AM6	AM5	AM4	AM3	AM2	AM1	AM0	
		Write:									
\$0218	CAN3IDAR4	Read:	AC7	AC6	AC5	AC4	AC3	AC2	AC1	AC0	
		Write:									
\$0219	CAN3IDAR5	Read:	AC7	AC6	AC5	AC4	AC3	AC2	AC1	AC0	
		Write:									
\$021A	CAN3IDAR6	Read:	AC7	AC6	AC5	AC4	AC3	AC2	AC1	AC0	
		Write:									



Registers

\$021B	CAN3IDAR7	Read:	AC7	AC6	AC5	AC4	AC3	AC2	AC1	AC0	CAN3
		Write:									
\$021C	CAN3IDMR4	Read:	AM7	AM6	AM5	AM4	AM3	AM2	AM1	AM0	
		Write:									
\$021D	CAN3IDMR5	Read:	AM7	AM6	AM5	AM4	AM3	AM2	AM1	AM0	
		Write:									
\$021E	CAN3IDMR6	Read:	AM7	AM6	AM5	AM4	AM3	AM2	AM1	AM0	
		Write:									
\$021F	CAN3IDMR7	Read:	AM7	AM6	AM5	AM4	AM3	AM2	AM1	AM0	
		Write:									
\$0220 - \$022F	CAN3RXFG	Read:	FOREGROUND RECEIVE BUFFER								
		Write:									
\$0230 - \$023F	CAN3TXFG	Read:	FOREGROUND TRANSMIT BUFFER								
		Write:									
\$0240	PTT	Read:	PTT7	PTT6	PTT5	PTT4	PTT3	PTT2	PTT1	PTT0	Port T
		Write:									
\$0241	PTIT	Read:	PTIT7	PTIT6	PTIT5	PTIT4	PTIT3	PTIT2	PTIT1	PTIT0	
		Write:									
\$0242	DDRT	Read:	DDRT7	DDRT7	DDRT5	DDRT4	DDRT3	DDRT2	DDRT1	DDRT0	
		Write:									
\$0243	RDRT	Read:	RDRT7	RDRT6	RDRT5	RDRT4	RDRT3	RDRT2	RDRT1	RDRT0	
		Write:									
\$0244	PERT	Read:	PERT7	PERT6	PERT5	PERT4	PERT3	PERT2	PERT1	PERT0	
		Write:									
\$0245	PPST	Read:	PPST7	PPST6	PPST5	PPST4	PPST3	PPST2	PPST1	PPST0	
		Write:									
\$0246	Reserved	Read:	0	0	0	0	0	0	0	0	
		Write:									
\$0247	Reserved	Read:	0	0	0	0	0	0	0	0	
		Write:									
\$0248	PTS	Read:	PTS7	PTS6	PTS5	PTS4	PTS3	PTS2	PTS1	PTS0	Port S
		Write:									
\$0249	PTIS	Read:	PTIS7	PTIS6	PTIS5	PTIS4	PTIS3	PTIS2	PTIS1	PTIS0	
		Write:									
\$024A	DDRS	Read:	DDRS7	DDRS7	DDRS5	DDRS4	DDRS3	DDRS2	DDRS1	DDRS0	
		Write:									
\$024B	RDRS	Read:	RDRS7	RDRS6	RDRS5	RDRS4	RDRS3	RDRS2	RDRS1	RDRS0	
		Write:									
\$024C	PERS	Read:	PERS7	PERS6	PERS5	PERS4	PERS3	PERS2	PERS1	PERS0	
		Write:									
\$024D	PPSS	Read:	PPSS7	PPSS6	PPSS5	PPSS4	PPSS3	PPSS2	PPSS1	PPSS0	
		Write:									
\$024E	WOMS	Read:	WOMS7	WOMS6	WOMS5	WOMS4	WOMS3	WOMS2	WOMS1	WOMS0	
		Write:									
\$024F	Reserved	Read:	0	0	0	0	0	0	0	0	
		Write:									



\$0250	PTM	Read:	PTM7	PTM6	PTM5	PTM4	PTM3	PTM2	PTM1	PTM0	Port M
		Write:									
\$0251	PTIM	Read:	PTIM7	PTIM6	PTIM5	PTIM4	PTIM3	PTIM2	PTIM1	PTIM0	
		Write:									
\$0252	DDRM	Read:	DDRM7	DDRM6	DDRM5	DDRM4	DDRM3	DDRM2	DDRM1	DDRM0	
		Write:									
\$0253	RDRM	Read:	RDRM7	RDRM6	RDRM5	RDRM4	RDRM3	RDRM2	RDRM1	RDRM0	
		Write:									
\$0254	PERM	Read:	PERM7	PERM6	PERM5	PERM4	PERM3	PERM2	PERM1	PERM0	
		Write:									
\$0255	PPSM	Read:	PPSM7	PPSM6	PPSM5	PPSM4	PPSM3	PPSM2	PPSM1	PPSM0	
		Write:									
\$0256	WOMM	Read:	WOMM7	WOMM6	WOMM5	WOMM4	WOMM3	WOMM2	WOMM1	WOMM0	
		Write:									
\$0257	Reserved	Read:	0	0	0	0	0	0	0	0	
		Write:									
\$0258	PTP	Read:	PTP7	PTP6	PTP5	PTP4	PTP3	PTP2	PTP1	PTP0	Port P
		Write:									
\$0259	PTIP	Read:	PTIP7	PTIP6	PTIP5	PTIP4	PTIP3	PTIP2	PTIP1	PTIP0	
		Write:									
\$025A	DDRP	Read:	DDRP7	DDRP6	DDRP5	DDRP4	DDRP3	DDRP2	DDRP1	DDRP0	
		Write:									
\$025B	RDRP	Read:	RDRP7	RDRP6	RDRP5	RDRP4	RDRP3	RDRP2	RDRP1	RDRP0	
		Write:									
\$025C	PERP	Read:	PERP7	PERP6	PERP5	PERP4	PERP3	PERP2	PERP1	PERP0	
		Write:									
\$025D	PPSP	Read:	PPSP7	PPSP6	PPSP5	PPSP4	PPSP3	PPSP2	PPSP1	PPSP0	
		Write:									
\$025E	PIEP	Read:	PIEP7	PIEP6	PIEP5	PIEP4	PIEP3	PIEP2	PIEP1	PIEP0	
		Write:									
\$025F	PIFP	Read:	PIFP7	PIFP6	PIFP5	PIFP4	PIFP3	PIFP2	PIFP1	PIFP0	
		Write:									
\$0260	PTH	Read:	PTH7	PTH6	PTH5	PTH4	PTH3	PTH2	PTH1	PTH0	Port H
		Write:									
\$0261	PTIH	Read:	PTIH7	PTIH6	PTIH5	PTIH4	PTIH3	PTIH2	PTIH1	PTIH0	
		Write:									
\$0262	DDRH	Read:	DDRH7	DDRH6	DDRH5	DDRH4	DDRH3	DDRH2	DDRH1	DDRH0	
		Write:									
\$0263	RDRH	Read:	RDRH7	RDRH6	RDRH5	RDRH4	RDRH3	RDRH2	RDRH1	RDRH0	
		Write:									
\$0264	PERH	Read:	PERH7	PERH6	PERH5	PERH4	PERH3	PERH2	PERH1	PERH0	
		Write:									
\$0265	PPSH	Read:	PPSH7	PPSH6	PPSH5	PPSH4	PPSH3	PPSH2	PPSH1	PPSH0	
		Write:									
\$0266	PIEH	Read:	PIEH7	PIEH6	PIEH5	PIEH4	PIEH3	PIEH2	PIEH1	PIEH0	
		Write:									

Registers

\$0267	PIFH	Read:	PIFH7	PIFH6	PIFH5	PIFH4	PIFH3	PIFH2	PIFH1	PIFH0	Port H
		Write:									
\$0268	PTJ	Read:	PTJ7	PTJ6	0	0	0	0	PTJ1	PTJ0	Port J
		Write:									
\$0269	PTIJ	Read:	PTIJ7	PTIJ6	0	0	0	0	PTIJ1	PTIJ0	
		Write:									
\$026A	DDRJ	Read:	DDRJ7	DDRJ7	0	0	0	0	DDRJ1	DDRJ0	
		Write:									
\$026B	RDRJ	Read:	RDRJ7	RDRJ6	0	0	0	0	RDRJ1	RDRJ0	
		Write:									
\$026C	PERJ	Read:	PERJ7	PERJ6	0	0	0	0	PERJ1	PERJ0	
		Write:									
\$026D	PPSJ	Read:	PPSJ7	PPSJ6	0	0	0	0	PPSJ1	PPSJ0	
		Write:									
\$026E	PIEJ	Read:	PIEJ7	PIEJ6	0	0	0	0	PIEJ1	PIEJ0	
		Write:									
\$026F	PIFJ	Read:	PIFJ7	PIFJ6	0	0	0	0	PIFJ1	PIFJ0	
		Write:									
\$0270 - \$027F	Reserved	Read:									
\$0280	CAN4CTL0	Read:	RXFRM	RXACT	CSWAI	SYNCH	TIME	WUPE	SLPRQ	INITRQ	CAN4
		Write:									
\$0281	CAN4CTL1	Read:	CANE	CLKSRC	LOOPB	LISTEN	0	WUPM	SLPAK	INITAK	
		Write:									
\$0282	CAN4BTR0	Read:	SJW1	SJW0	BRP5	BRP4	BRP3	BRP2	BRP1	BRP0	
		Write:									
\$0283	CAN4BTR1	Read:	SAMP	TSEG22	TSEG21	TSEG20	TSEG13	TSEG12	TSEG11	TSEG10	
		Write:									
\$0284	CAN4RFLG	Read:	WUPIF	CSCIF	RSTAT1	RSTAT0	TSTAT1	TSTAT0	OVRIF	RXF	
		Write:									
\$0285	CAN4RIER	Read:	WUPIE	CSCIE	RSTATE1	RSTATE0	TSTATE1	TSTATE0	OVRIE	RXFIE	
		Write:									
\$0286	CAN4TFLG	Read:	0	0	0	0	0	TXE2	TXE1	TXE0	
		Write:									
\$0287	CAN4TIER	Read:	0	0	0	0	0	TXEIE2	TXEIE1	TXEIE0	
		Write:									
\$0288	CAN4TARQ	Read:	0	0	0	0	0	ABTRQ2	ABTRQ1	ABTRQ0	
		Write:									
\$0289	CAN4TAAK	Read:	0	0	0	0	0	ABTAK2	ABTAK1	ABTAK0	
		Write:									
\$028A	CAN4TBSEL	Read:	0	0	0	0	0	TX2	TX1	TX0	
		Write:									
\$028B	CAN4IDAC	Read:	0	0	IDAM1	IDAM0	0	IDHIT2	IDHIT1	IDHIT0	
		Write:									
\$028C	Reserved	Read:	0	0	0	0	0	0	0	0	
		Write:									



\$028D	Reserved	Read:	0	0	0	0	0	0	0	CAN4	
		Write:									
\$028E	CAN4RXERR	Read:	RXERR7	RXERR6	RXERR5	RXERR4	RXERR3	RXERR2	RXERR1		RXERR0
		Write:									
\$028F	CAN4TXERR	Read:	TXERR7	TXERR6	TXERR5	TXERR4	TXERR3	TXERR2	TXERR1		TXERR0
		Write:									
\$0290	CAN4IDAR0	Read:	AC7	AC6	AC5	AC4	AC3	AC2	AC1		AC0
		Write:									
\$0291	CAN4IDAR1	Read:	AC7	AC6	AC5	AC4	AC3	AC2	AC1		AC0
		Write:									
\$0292	CAN4IDAR2	Read:	AC7	AC6	AC5	AC4	AC3	AC2	AC1		AC0
		Write:									
\$0293	CAN4IDAR3	Read:	AC7	AC6	AC5	AC4	AC3	AC2	AC1		AC0
		Write:									
\$0294	CAN4IDMR0	Read:	AM7	AM6	AM5	AM4	AM3	AM2	AM1		AM0
		Write:									
\$0295	CAN4IDMR1	Read:	AM7	AM6	AM5	AM4	AM3	AM2	AM1		AM0
		Write:									
\$0296	CAN4IDMR2	Read:	AM7	AM6	AM5	AM4	AM3	AM2	AM1		AM0
		Write:									
\$0297	CAN4IDMR3	Read:	AM7	AM6	AM5	AM4	AM3	AM2	AM1		AM0
		Write:									
\$0298	CAN4IDAR4	Read:	AC7	AC6	AC5	AC4	AC3	AC2	AC1		AC0
		Write:									
\$0299	CAN4IDAR5	Read:	AC7	AC6	AC5	AC4	AC3	AC2	AC1		AC0
		Write:									
\$029A	CAN4IDAR6	Read:	AC7	AC6	AC5	AC4	AC3	AC2	AC1		AC0
		Write:									
\$029B	CAN4IDAR7	Read:	AC7	AC6	AC5	AC4	AC3	AC2	AC1	AC0	
		Write:									
\$029C	CAN4IDMR4	Read:	AM7	AM6	AM5	AM4	AM3	AM2	AM1	AM0	
		Write:									
\$029D	CAN4IDMR5	Read:	AM7	AM6	AM5	AM4	AM3	AM2	AM1	AM0	
		Write:									
\$029E	CAN4IDMR6	Read:	AM7	AM6	AM5	AM4	AM3	AM2	AM1	AM0	
		Write:									
\$029F	CAN4IDMR7	Read:	AM7	AM6	AM5	AM4	AM3	AM2	AM1	AM0	
		Write:									
\$02A0 - \$02AF	CAN4RXFG	Read:	FOREGROUND RECEIVE BUFFER								
		Write:									
\$02B0 - \$02BF	CAN4TXFG	Read:	FOREGROUND TRANSMIT BUFFER								
		Write:									
\$02C0 - \$02FF	Reserved	Read:									
\$0300 - \$03FF	Unimplemented	Read:									



Operating Modes

Contents

Introduction	91
Operating Modes	91
Background Debug Mode	102
Security	103

Introduction

Eight possible operating modes determine the operating configuration of the MC9S12DP256. Each mode has an associated default memory map and external bus configuration.

Operating Modes

The operating mode out of reset is determined by the states of the MODC, MODB, and MODA pins during reset.

The MODC, MODB, and MODA bits in the MODE register show current operating mode and provide limited mode switching during operation. The states of the MODC, MODB, and MODA pins are latched into these bits on the rising edge of the reset signal.

Table 13 Mode Selection

Input BKGD & bit MODC	Input & bit MODB	Input & bit MODA	Mode Description
0	0	0	Special Single Chip, BDM allowed and ACTIVE. BDM is “allowed” in all other modes but a serial command is required to make BDM “active”.
0	0	1	Emulation Expanded Narrow, BDM allowed
0	1	0	Special Test (Expanded Wide), BDM allowed
0	1	1	Emulation Expanded Wide, BDM allowed
1	0	0	Normal Single Chip, BDM allowed
1	0	1	Normal Expanded Narrow, BDM allowed
1	1	0	Peripheral; BDM allowed but bus operations would cause bus conflicts (must not be used)
1	1	1	Normal Expanded Wide, BDM allowed

There are two basic types of operating modes:

Normal modes — some registers and bits are protected against accidental changes.

Special modes — allow greater access to protected control registers and bits for special purposes such as testing.

A system development and debug feature, background debug mode (BDM), is available in all modes. In special single-chip mode, BDM is active immediately after reset.

Some aspects of Port E are not mode dependent. Bit 1 of Port E is a general purpose input or the \overline{IRQ} interrupt input. \overline{IRQ} can be enabled by bits in the CPUs condition codes register but it is inhibited at reset so this pin is initially configured as a simple input with a pullup. Bit 0 of Port E is a general purpose input or the \overline{XIRQ} interrupt input. \overline{XIRQ} can be enabled by bits in the CPUs condition codes register but it is inhibited at reset so this pin is initially configured as a simple input with a pullup. The ESTR bit in the EBICTL register is set to one by reset in any user mode. This assures that the reset vector can be fetched even if it is located in an external slow memory device. The PE6/MODB/IPIPE1 and

PE5/MODA/IPIPE0 pins act as high-impedance mode select inputs during reset.

The following paragraphs discuss the default bus setup and describe which aspects of the bus can be changed after reset on a per mode basis.

Normal Operating Modes

These modes provide three operating configurations. Background debug is available in all three modes, but must first be enabled for some operations by means of a BDM background command, then activated.

Normal Single-Chip Mode — There is no external expansion bus in this mode. All pins of Ports A, B and E are configured as general purpose I/O pins Port E bits 1 and 0 are available as general purpose input only pins with internal pullups enabled. All other pins of Port E are bidirectional I/O pins that are initially configured as high-impedance inputs with internal pullups enabled. Ports A and B are configured as high-impedance inputs with their internal pullups disabled.

The pins associated with Port E bits 6, 5, 3, and 2 cannot be configured for their alternate functions IPIPE1, IPIPE0, $\overline{\text{LSTRB}}$, and $\text{R}/\overline{\text{W}}$ while the MCU is in single chip modes. In single chip modes, the associated control bits PIPOE, LSTRE, and RDWE are reset to zero. Writing the opposite state into them in single chip mode does not change the operation of the associated Port E pins.

In normal single chip mode, the MODE register is writable one time. This allows a user program to change the bus mode to special single chip or narrow or wide expanded mode and/or turn on visibility of internal accesses.

Port E, bit 4 can be configured for a free-running E clock output by clearing NECLK=0. Typically the only use for an E clock output while the MCU is in single chip modes would be to get a constant speed clock for use in the external application system.

Normal Expanded Wide Mode — In expanded wide modes, Ports A and B are configured as a 16-bit multiplexed address and data bus and Port E bit 4 is configured as the E clock output signal. These signals allow external memory and peripheral devices to be interfaced to the MCU.

Port E pins other than PE4/ECLK are configured as general purpose I/O pins (initially high-impedance inputs with internal pullup resistors enabled). Control bits PIPOE, NECLK, LSTRE, and RDWE in the PEAR register can be used to configure Port E pins to act as bus control outputs instead of general purpose I/O pins.

It is possible to enable the pipe status signals on Port E bits 6 and 5 by setting the PIPOE bit in PEAR, but it would be unusual to do so in this mode. Development systems where pipe status signals are monitored would typically use the special variation of this mode.

The Port E bit 2 pin can be reconfigured as the $R\overline{W}$ bus control signal by writing “1” to the RDWE bit in PEAR. If the expanded system includes external devices that can be written, such as RAM, the RDWE bit would need to be set before any attempt to write to an external location. If there are no writable resources in the external system, PE2 can be left as a general purpose I/O pin.

The Port E bit 3 pin can be reconfigured as the \overline{LSTRB} bus control signal by writing “1” to the LSTRE bit in PEAR. The default condition of this pin is a general purpose input because the \overline{LSTRB} function is not needed in all expanded wide applications.

The Port E bit 4 pin is initially configured as ECLK output with stretch. The E clock output function depends upon the settings of the NECLK bit in the PEAR register, the IVIS bit in the MODE register and the ESTR bit in the EBICTL register. The E clock is available for use in external select decode logic or as a constant speed clock for use in the external application system.

Normal Expanded Narrow Mode — This mode is used for lower cost production systems that use 8-bit wide external EPROMs or RAMs. Such systems take extra bus cycles to access 16-bit locations but this may be preferred over the extra cost of additional external memory devices.

Ports A and B are configured as a 16-bit address bus and Port A is multiplexed with data. Internal visibility is not available in this mode because the internal cycles would need to be split into two 8-bit cycles.

Since the PEAR register can only be written one time in this mode, use care to set all bits to the desired states during the single allowed write.

The PE3/ $\overline{\text{LSTRB}}$ pin is always a general purpose I/O pin in normal expanded narrow mode. Although it is possible to write the LSTRE bit in PEAR to “1” in this mode, the state of LSTRE is overridden and Port E bit 3 cannot be reconfigured as the $\overline{\text{LSTRB}}$ output.

It is possible to enable the pipe status signals on Port E bits 6 and 5 by setting the PIPOE bit in PEAR, but it would be unusual to do so in this mode. $\overline{\text{LSTRB}}$ would also be needed to fully understand system activity. Development systems where pipe status signals are monitored would typically use special expanded wide mode or occasionally special expanded narrow mode.

The PE4/ECLK pin is initially configured as ECLK output with stretch. The E clock output function depends upon the settings of the NECLK bit in the PEAR register, the IVIS bit in the MODE register and the ESTR bit in the EBICTL register. In normal expanded narrow mode, the E clock is available for use in external select decode logic or as a constant speed clock for use in the external application system.

The PE2/ $\overline{\text{R}\overline{\text{W}}}$ pin is initially configured as a general purpose input with a pullup but this pin can be reconfigured as the $\overline{\text{R}\overline{\text{W}}}$ bus control signal by writing “1” to the RDWE bit in PEAR. If the expanded narrow system includes external devices that can be written such as RAM, the RDWE bit would need to be set before

any attempt to write to an external location. If there are no writable resources in the external system, PE2 can be left as a general purpose I/O pin.

Internal Visibility — Internal visibility is available when the MCU is operating in expanded wide modes or special narrow mode. It is not available in single-chip, peripheral or normal expanded narrow modes. Internal visibility is enabled by setting the IVIS bit in the MODE register.

If an internal access is made while E, R/\overline{W} , and \overline{LSTRB} are configured as bus control outputs and internal visibility is off (IVIS=0), E will remain low for the cycle, R/\overline{W} will remain high, and address, data and the \overline{LSTRB} pins will remain at their previous state.

When internal visibility is enabled (IVIS=1), certain internal cycles will be blocked from going external. During cycles when the BDM is selected, R/\overline{W} will remain high, data will maintain its previous state, and address and \overline{LSTRB} pins will be updated with the internal value. During CPU no access cycles when the BDM is not driving, R/\overline{W} will remain high, and address, data and the \overline{LSTRB} pins will remain at their previous state.

Emulation Expanded Wide Mode — In expanded wide modes, Ports A and B are configured as a 16-bit multiplexed address and data bus and Port E provides bus control and status signals. These signals allow external memory and peripheral devices to be interfaced to the MCU. These signals can also be used by a logic analyzer to monitor the progress of application programs.

The bus control related pins in Port E (PE7/NOACC, PE6/MODB/IPIPE1, PE5/MODA/IPIPE0, PE4/ECLK, PE3/ $\overline{LSTRB}/\overline{TAGLO}$, and PE2/ R/\overline{W}) are all configured to serve their bus control output functions rather than general purpose I/O. Notice that writes to the bus control enable bits in the PEAR register in special mode are restricted.

The main difference between special modes and normal modes is that some of the bus control and system control signals cannot be written in special modes.

Emulation Expanded Narrow Mode — Expanded narrow modes are intended to allow connection of single 8-bit external memory devices for lower cost systems that do not need the performance of a full 16-bit external data bus. Accesses to internal resources that have been mapped external (i.e. PORTA, PORTB, DDRA, DDRB, PORTE, DDRE, PEAR, PUCR, RDRIV) will be accessed with a 16-bit data bus on Ports A and B. Accesses of 16-bit external words to addresses which are normally mapped external will be broken into two separate 8-bit accesses using Port A as an 8-bit data bus. Internal operations continue to use full 16-bit data paths. They are only visible externally as 16-bit information if IVIS=1.

Ports A and B are configured as multiplexed address and data output ports. During external accesses, address A15, data D15 and D7 are associated with PA7, address A0 is associated with PB0 and data D8 and D0 are associated with PA0. During internal visible accesses and accesses to internal resources that have been mapped external, address A15 and data D15 is associated with PA7 and address A0 and data D0 is associated with PB0.

The bus control related pins in Port E (PE7/NOACC, PE6/MODB/IPIPE1, PE5/MODA/IPIPE0, PE4/ECLK, PE3/ $\overline{\text{LSTRB}}$ / $\overline{\text{TAGLO}}$, and PE2/ $\overline{\text{R/W}}$) are all configured to serve their bus control output functions rather than general purpose I/O. Notice that writes to the bus control enable bits in the PEAR register in special mode are restricted.

The main difference between special modes and normal modes is that some of the bus control and system control signals cannot be written in special modes.

Operating Modes

Special Operating Modes

There are two special operating modes that correspond to normal operating modes. These operating modes are commonly used in factory testing and system development.

Special Single-Chip Mode — When the MCU is reset in this mode, the background debug mode is enabled and “active”. The MCU does not fetch the reset vector and execute application code as it would in other modes. Instead the active background mode is in control of CPU execution and BDM firmware is waiting for additional serial commands through the BKGD pin. When a serial command instructs the MCU to return to normal execution, the system will be configured as described below unless the reset states of internal control registers have been changed through background commands after the MCU was reset.

There is no external expansion bus after reset in this mode. Ports A and B are initially simple bidirectional I/O pins that are configured as high-impedance inputs with internal pullups disabled; however, writing to the mode select bits in the MODE register (which is allowed in special modes) can change this after reset. All of the Port E pins (except PE4/ECLK) are initially configured as general purpose high-impedance inputs with pullups enabled. PE4/ECLK is configured as the E clock output in this mode.

The pins associated with Port E bits 6, 5, 3, and 2 cannot be configured for their alternate functions IPIPE1, IPIPE0, $\overline{\text{LSTRB}}$, and $\overline{\text{R/W}}$ while the MCU is in single chip modes. In single chip modes, the associated control bits PIPOE, LSTRE and RDWE are reset to zero. Writing the opposite value into these bits in single chip mode does not change the operation of the associated Port E pins.

Port E, bit 4 can be configured for a free-running E clock output by clearing NECLK=0. Typically the only use for an E clock output while the MCU is in single chip modes would be to get a constant speed clock for use in the external application system.

Special Test Mode — In expanded wide modes, Ports A and B are configured as a 16-bit multiplexed address and data bus and Port E provides bus control and status signals. In special test mode, the write protection of many control bits is lifted so that they can be thoroughly tested without needing to go through reset.

Test Operating Mode

There is a test operating mode in which an external master, such as an I.C. tester, can control the on-chip peripherals.

Peripheral Mode — This mode is intended for Motorola factory testing of the MCU. In this mode, the CPU is inactive and an external (tester) bus master drives address, data and bus control signals in through Ports A, B and E. In effect, the whole MCU acts as if it was a peripheral under control of an external CPU. This allows faster testing of on-chip memory and peripherals than previous testing methods. Since the mode control register is not accessible in peripheral mode, the only way to change to another mode is to reset the MCU into a different mode. Background debugging should not be used while the MCU is in special peripheral mode as internal bus conflicts between BDM and the external master can cause improper operation of both functions.

Operating Modes

MODE — Mode Register

\$000B

	Bit 7	6	5	4	3	2	1	Bit 0	
Read	MODC	MODB	MODA	0	IVIS	0	EMK	EME	
RESET:	0	0	0	0	0	0	0	0	Special Single Chip
RESET:	0	0	1	0	1	0	1	1	Emulation Exp Nar
RESET:	0	1	0	0	1	0	0	0	Special Test
RESET:	0	1	1	0	1	0	1	1	Emulation Exp Wide
RESET:	1	0	0	0	0	0	0	0	Normal Single Chip
RESET:	1	0	1	0	0	0	0	0	Normal Exp Narrow
RESET:	1	1	0	0	0	0	0	0	Peripheral
RESET:	1	1	1	0	0	0	0	0	Normal Exp Wide

The MODE register is used to establish the operating mode and other miscellaneous functions (i.e. internal visibility, clocks stop in wait mode and emulation of Port E and K.

In peripheral modes this register is not accessible but it is reset as shown to configure system features. Changes to bits in the MODE register are delayed one cycle after the write.

This register is not in the on-chip map in emulation and peripheral modes.

The MODE register controls the MCU operating mode and various configuration options.

MODC, MODB, MODA — Mode Select bits

These bits indicate the current operating mode.

If MODA=1, then MODC, MODB, MODA are write never.

If MODC=MODA=0, then MODC, MODB, MODA are write anytime except that you cannot change to or from peripheral mode.

If MODC=1, MODB=0 and MODA=0, then MODC is write never, MODB, MODA are write once, except that you cannot change to peripheral, special test, special single chip or emulation modes.

Table 14 MODC, MODB, MODA Write Capability

MODC	MODB	MODA	Mode	MODx Write Capability
0	0	0	Special Single Chip	MODC, B, A write anytime but not to 110 ⁽¹⁾
0	0	1	Emulation Exp Narrow	no write
0	1	0	Special Test	MODC, B, A write anytime but not to 110 ¹
0	1	1	Emulation Exp Wide	no write
1	0	0	Normal Single Chip	MODC write never, MODB, A write once but not to 110
1	0	1	Normal Expanded Narrow	no write
1	1	0	Special Peripheral	no write
1	1	1	Normal Expanded Wide	no write

1. If you are in a special single chip or special test mode and you write to this register, changing to normal single chip mode, then one allowed write to this register remains even if you write to a special mode. If you write to normal expanded or emulation mode, then no writes remain.

IVIS — Internal Visibility (for both read and write accesses)

This bit determines whether internal accesses generate a bus cycle that is visible on the external bus.

Normal: write once

Emulation: write never

Special: write anytime

1 = Internal bus operations are visible on external bus.

0 = No visibility of internal bus operations on external bus.

EMK — Emulate Port K

Normal and Emulation: write never

Special: write anytime

1 = If in any expanded mode or special peripheral mode, PORTK and DDRK are removed from the memory map.

0 = PORTK and DDRK are in the memory map so Port K can be used for general purpose I/O.

EME — Emulate Port E

Normal and Emulation: write never

Special: write anytime

1 = If in any expanded mode or special peripheral mode, PORTE and DDRE are removed from the memory map. Removing the registers from the map allows the user to emulate the function of these registers externally.

0 = PORTE and DDRE are in the memory map so Port E can be used for general purpose I/O.

In single-chip modes, PORTE and DDRE are always in the map regardless of the state of this bit.

Background Debug Mode

Background debug mode (BDM) is an auxiliary operating mode that is used for system development. BDM is implemented in on-chip hardware and provides a full set of debug operations. Some BDM commands can be executed while the CPU is operating normally. Other BDM commands are firmware based, and require the BDM firmware to be enabled and active for execution.

In special single-chip mode, BDM is enabled and active immediately out of reset. BDM is available in all other operating modes, but must be enabled before it can be activated. BDM should not be used in special peripheral mode because of potential bus conflicts.

Once enabled, background mode can be made active by a serial command sent via the BKGD pin or execution of a CPU12 BGND instruction. While background mode is active, the CPU can interpret special debugging commands, and read and write CPU registers, peripheral registers, and locations in memory.

While BDM is active, the CPU executes code located in a small on-chip ROM mapped to addresses \$FF20 to \$FFFF, and BDM control registers are accessible at addresses \$FF00 to \$FF06. The BDM ROM replaces the regular system vectors while BDM is active. While BDM is active, the

user memory from \$FF00 to \$FFFF is not in the map except through serial BDM commands.

Security

The device will make available a security feature preventing the unauthorized read and write of the memory contents. This feature allows:

- Protection of the contents of FLASH,
- Protection of the contents of EEPROM,
- Operation in single-chip mode,
- Operation from external memory with internal FLASH and EEPROM disabled.

The user must be reminded that part of the security must lie with the user's code. An extreme example would be user's code that dumps the contents of the internal program. This code would defeat the purpose of security.

At the same time the user may also wish to put a "back door" in the user's program. An example of this is the user downloads a "key" through the SCI which allows access to a programming routine that updates parameters stored in EEPROM.

Operation

Securing the Microcontroller

Once the user has programmed the FLASH and EEPROM (if desired), the part can be secured by programming the security bits located in the FLASH module. These non-volatile bits will keep the part secured through resetting the part and through powering down the part.

The security byte resides in a portion of the Flash array.

Two bits are used for security. The state of the security bits and the resulting state of security are shown in [Table 15](#). Note that there are three secured bit combinations and only one unsecured combination.

Operating Modes

The user can select any of the three combinations to secure the microcontroller.

Table 15 : Security Bits

sec1	sec0	secreq
0	0	1 (secured)
0	1	1 (secured)
1	0	0 (unsecured)
1	1	1 (secured)

CAUTION: Check the Flash Specification for more details on the security configuration.

Operation of the Secured Microcontroller

Normal Single Chip Mode

This will be the most common usage of the secured part. Everything will appear the same as if the part was not secured with the exception of BDM operation. The BDM operation will be blocked.

Executing from External Memory

The user may wish to execute from external space with a secured microcontroller. This is accomplished by resetting directly into expanded mode. The internal FLASH and EEPROM will be disabled. BDM operations will be blocked.

Unsecuring the Microcontroller

In order to unsecure the microcontroller, the internal FLASH and EEPROM must be erased. This can be done through an external program in expanded mode.

Once the user has erased the FLASH and EEPROM, the part can be reset into special single chip mode. This invokes a program that verifies the erasure of the internal FLASH and EEPROM. Once this program completes, the user can erase and program the FLASH security bits to



the unsecured state. This is generally done through the BDM, but the user could also change to expanded mode (by writing the mode bits through the BDM) and jumping to an external program (again through BDM commands). Note that if the part goes through a reset before the security bits are reprogrammed to the unsecure state, the part will be secured again.



Resource Mapping

Contents

Introduction	107
Internal Resource Mapping	107
Flash EEPROM mapping through internal Memory Expansion	111
Miscellaneous System Control Register	118
Memory Maps	119

Introduction

After reset, most system resources can be mapped to other addresses by writing to the appropriate control registers.

Internal Resource Mapping

The internal register block, RAM, and EEPROM have default locations within the 64K byte standard address space but may be reassigned to other locations during program execution by setting bits in mapping registers INITRG, INITRM, and INITEE. During normal operating modes these registers can be written once. It is advisable to explicitly establish these resource locations during the initialization phase of program execution, even if default values are chosen, in order to protect the registers from inadvertent modification later.

Writes to the mapping registers go into effect between the cycle that follows the write and the cycle after that. To assure that there are no unintended operations, a write to one of these registers should be followed with a NOP instruction.

If conflicts occur when mapping resources, the register block will take precedence over the other resources; RAM or EEPROM addresses occupied by the register block will not be available for storage. When active, BDM ROM takes precedence over other resources, although a conflict between BDM ROM and register space is not possible. The following table shows resource mapping precedence. Only one module will be selected at a time. In the case of more than one module sharing a space only the highest priority module will be selected. For example, if the RAM and registers are mapped to the same space, then the first 1K bytes will be the registers and the section of RAM which “shares” that space will not be available in the memory map. The remaining RAM will be visible and available. If the internal RAM, registers or BDM (if active) are mapped to the same space as the EEPROM, they will have priority over the EEPROM and the EEPROM locations covered by the RAM, registers or BDM ROM will not be visible in the memory map.

NOTE: *Generally it is not a good idea to map RAM and registers to the same location because of the significant amount of RAM which would become unusable.*

Table 16 Mapping Precedence

Precedence	Resource
Highest	BDM space (Internal) when BDM is active this 256 byte block of registers and ROM appear at \$FF00 – \$FFFF
...	Register Space (Internal) – 1K bytes fully blocked for registers
...	RAM (Internal) – 12K bytes
...	EEPROM – 4K bytes
...	On-Chip Flash EEPROM – 256K bytes
Lowest	Remaining external

In expanded modes, all address space not used by internal resources is by default external memory.

Register Block Mapping

After reset the 1K byte register block resides at location \$0000 but can be reassigned to any 2K byte boundary within the first 32K byte of the 64K byte address space. Mapping of internal registers is controlled by five bits in the INITRG register. This register initializes the internal Registers position.

Normal and Emulation: Write once.

Special: Write anytime

Writes to this register take one cycle to go into effect.

Read: Anytime.

Reset to \$00 (Registers located from \$0000 to \$03FF).

INITRG — Initialization of Internal Register Position Register

Address Offset: \$0011

	Bit 7	6	5	4	3	2	1	Bit 0
	0	REG14	REG13	REG12	REG11	0	0	0
Reset:	0	0	0	0	0	0	0	0

REG[15:11] — Internal register map position

These five bits specify the upper five bits of the register block's address. INITRG Bit 7 is always set to "0".

RAM Mapping

The MC9S12DP256 has 12K bytes of fully static RAM that is used for storing instructions, variables, and temporary data during program execution. After reset, RAM addressing begins at location \$1000 but can be assigned to any 16K byte boundary within the standard 64K byte address space. It occupies either the first 12K of the 16K space (i.e. \$0000 – \$2FFF, \$4000 – \$6FFF, etc.) or the last 12K of the 16K space (i.e. \$1000 – \$3FFF, \$5000 – \$7FFF, etc.). Mapping of internal RAM is controlled by three bits in the INITRM register.

Normal and Emulation: Write once.

Special: Write anytime.

NOTE: *Writes to this register take one cycle to go into effect.*

Resource Mapping

Read: Anytime.

Reset: \$09 (RAM located from \$1000 – \$3FFF)

INITRM — Initialization of Internal RAM Position Register

Address Offset: \$0010

	Bit 7	6	5	4	3	2	1	Bit 0
	RAM15	RAM14	RAM13	RAM12	RAM11	0	0	RAMHAL
Reset:	0	0	0	0	1	0	0	1

RAM[15:11] — Internal RAM map position

This register initializes the internal RAM position. Only the upper two bits define the 16K page the RAM resides in. Bits 13–11 can be written and read, but are ignored in determining the RAM position.

RAMHAL — Internal RAM map alignment

This register initializes the internal RAM alignment within the 16K page.

- 1 = The 12K RAM is aligned to the top of the 16K page (\$FFFF)
- 0 = The 12K RAM is aligned to the bottom of the 16K page (\$0000)

EEPROM Mapping

The MC9S12DP256 has 4K bytes of EEPROM which is activated by the EEON bit in the INITEE register. Mapping of internal EEPROM is controlled by four bits in the INITEE register. After reset EEPROM address space begins at location \$0000 but can be mapped to any 4K byte boundary within the standard 64K byte address space.

This register initializes the internal EEPROM position.

Normal and Emulation: Write once, except for the EEON bit which can be written anytime.

Special: Write anytime

NOTE: *Writes to this register take one cycle to go into effect.*

Read: Anytime.

Reset: \$01 (EEPROM located from \$0000 – \$0FFF)

INITEE— Initialization of Internal EEPROM Position Register

Address Offset: \$0012

	Bit 7	6	5	4	3	2	1	Bit 0
	EE15	EE14	EE13	EE12	0	0	0	EEON
Reset:	0	0	0	0	0	0	0	1

EE[15:12] — Internal EEPROM map position

These bits specify the upper four bits of the 16-bit EEPROM address.

EEON — internal EEPROM On (Enabled)

This bit enables the EEPROM in the memory map.

Read or write anytime.

1 = Place EEPROM in the memory map at the address selected by EE15–EE12.

0 = Removes the EEPROM from the map.

Flash EEPROM mapping through internal Memory Expansion

The Page Index register or PPAGE provides memory management for the MC9S12DP256. PPAGE consists of six bits to indicate which physical location is active within the windows of the MC9S12DP256.

The user’s program page window consists of 16K Flash EEPROM bytes. Sixteen of 64 pages are viewed through this window for a total of 256K accessible Flash EEPROM bytes.

MC9S12DP256 has a seven pin port, port K, for emulation and for general purpose I/O. Six pins are used to determine which Flash EEPROM array page is being accessed. Reference the PORTK register (XAB[19:14] bits) for more information.

Resource Mapping
Program space expansion

There are 256K bytes of Flash EEPROM for MC9S12DP256. With a 64K byte address space, the PPAGE register is needed to perform on chip memory expansion. A program space window of 16K byte pages is located from \$8000 to \$BFFF. Six page indices are used to point to one of 64 different 16K byte pages. A total of 16 pages (\$30 – \$3F) are occupied by the 256K Flash block. The other pages are available for expanded addressing if enabled.

Table 17 Program Space Page Index

Index 5 (PPAGE 5)	Index 4 (PPAGE 4)	Index 3 (PPAGE 3)	Index 2 (PPAGE 2)	Index 1 (PPAGE 1)	Index 0 (PPAGE 0)	16K Program space Page
0	0	0	0	0	0	ext. 16K byte Page 0
0	0	0	0	0	1	ext. 16K byte Page 1
0	0	0	0	1	0	ext. 16K byte Page 2
..
1	0	1	1	1	1	ext. 16K byte Page \$2F
1	1	0	0	0	0	Flash 16K byte Page \$30
1	1	0	0	0	1	Flash 16K byte Page \$31
1	1	0	0	1	0	Flash 16K byte Page \$32
1	1	0	0	1	1	Flash 16K byte Page \$33
1	1	0	1	0	0	Flash 16K byte Page \$34
1	1	0	1	0	1	Flash 16K byte Page \$35
1	1	0	1	1	0	Flash 16K byte Page \$36
1	1	0	1	1	0	Flash 16K byte Page \$37
1	1	1	0	0	0	Flash 16K byte Page \$38
1	1	1	0	0	1	Flash 16K byte Page \$39
1	1	1	0	1	0	Flash 16K byte Page \$3A
1	1	1	0	1	1	Flash 16K byte Page \$3B
1	1	1	1	0	0	Flash 16K byte Page \$3C
1	1	1	1	0	1	Flash 16K byte Page \$3D
1	1	1	1	1	0	Flash 16K byte Page \$3E*
1	1	1	1	1	1	Flash 16K byte Page \$3F*

* The 16K byte flash in program space page \$3E (62) can also be accessed at a fixed location from \$4000 to \$7FFF is based on state of ROMHM bit in the MISC register. The 16K byte flash in program space page \$3F (63) can also be accessed at a fixed location from \$C000 to \$FFFF.

**Page Index
register
descriptions**

PORTK — Port K Data Register

Address Offset: \$0032

	Bit 7	6	5	4	3	2	1	Bit 0
Port:	Bit 7	6	0	0	0	2	1	Bit 0
Reset:	Unaffected by reset							
Alt. pin function	$\overline{\text{ECS}}/\text{ROMONE}$	0	XAB19	XAB18	XAB17	XAB16	XAB15	XAB14

Read and write anytime

Writes do not change pin state when pin configured for page index emulation output.

This port is associated with the internal memory expansion emulation pins. When the port is not enabled to emulate the internal memory expansion, the port pins are used as general-purpose I/O. This register is not in the map in peripheral mode or in expanded modes while the EMK bit in the MODE register is set.

When inputs, these pins can be selected to be high impedance or pulled up based upon the state of the PUPKE bit in the PUCR register (in the MEBI).

Bit 7— Port K bit 7.

This bit is used as an emulation chip select signal for the emulation of the internal memory expansion, or as general purpose I/O, depending upon the state of the EMK bit in the MODE register. See **Table 18 Expanded address decode** for additional details on when this signal will be active.

The value on this pin during reset determines the reset state of the ROMON bit during reset into all expanded modes.

Bit 5 – Bit 0 — Port K bits 5 – 0.

These six bits are used to determine which array page is being accessed. They can be viewed as expanded addresses XAB19 – XAB15 and XAB14 of the 20-bit address used to access the 256K byte Flash EEPROM array. The decoding is done internally based upon the regular address bus bits 15 and 14 (AB[15:14]) and the state of the ROMHM bit in the MISC register. The decoding is performed regardless of the state of the ROMON bit in the MISC register. Alternatively, these bits can be used for general purpose I/O depending upon the state of the EMK bit in the MODE register.

Table 18 Expanded address decode

A15	A14	ROMHM	\overline{ECS}	XAB19	XAB18	XAB17	XAB16	XAB15	XAB14
0	0	X	1	PIX5	PIX4	PIX3	PIX2	PIX1	PIX0
0	1	0	0	1	1	1	1	1	0
0	1	1	1	PIX5	PIX4	PIX3	PIX2	PIX1	PIX0
1	0	X	0	PIX5	PIX4	PIX3	PIX2	PIX1	PIX0
1	1	X	0	1	1	1	1	1	1

DDRK — Port K Data Direction Register

Address Offset: \$0033

	Bit 7	6	5	4	3	2	1	Bit 0
	DDK7	0	DDK5	DDK4	DDK3	DDK2	DDK1	DDK0
Reset:	0	0	0	0	0	0	0	0

Read and write: anytime.

This register determines the primary direction for each port K pin configured as general-purpose I/O. The value in a DDR bit also affects the source of data for reads of the corresponding PORTK register. If the DDR bit is zero (input) the buffered pin input is read. If the DDR bit is one (output) the output of the port data latch is read.

This register is not in the map in peripheral mode or in expanded modes while the EMK bit in the MODE register is set

Bit 7, Bit 5 – Bit 0 — The data direction select for Port K

1 = Associated pin is an output.

0 = Associated pin is a high-impedance input.

CAUTION: *It is unwise to write PORTK and DDRK as a word access. If you are changing Port K pins from inputs to outputs, the data may have extra transitions during the write. It is best to initialize PORTK before enabling as outputs.*

CAUTION: *To ensure that you read the correct value from the PORTK pins, always wait at least two cycles after writing to the DDRK register before reading from the PORTK register.*

Resource Mapping
PPAGE — (Program) Page Index Register

Address Offset: \$0030

Bit 7	6	5	4	3	2	1	Bit 0
0	0	PIX5	PIX4	PIX3	PIX2	PIX1	PIX0
Reset:	0	0	0	0	0	0	0

This register determines the active page viewed through the Program Page Window from \$8000 – \$BFFF. CALL and RTC instructions have a special single wire mechanism to read and write this register without using an address bus.

There are 256K bytes of Flash EEPROM. With a 64K byte address space the PPAGE register is needed to perform on chip memory expansion. A Program Page Window of 16K byte pages is located from \$8000 to \$BFFF. Six page indices are used to point to one of 64 different 16K byte Flash EEPROM pages.

Read and write: anytime.

PIX5 – PIX0 — These six bits are used to select which of the 64 Flash EEPROM array or expanded pages is currently being accessed.

Table 19 Program space page index

PIX5	PIX4	PIX3	PIX2	PIX1	PIX0	Program Space Selected
0	0	0	0	0	0	External 16K Page 0
0	0	0	0	0	1	External 16K Page 1
...	External 16K Pages 2 .. \$2E
1	0	1	1	1	1	16K Flash EEPROM Page \$2F
1	1	0	0	0	0	16K Flash EEPROM Page \$30
1	1	0	0	0	1	16K Flash EEPROM Page \$31
1	1	0	0	1	0	16K Flash EEPROM Page \$32
1	1	0	0	1	1	16K Flash EEPROM Page \$33
1	1	0	1	0	0	16K Flash EEPROM Page \$34
1	1	0	1	0	1	16K Flash EEPROM Page \$35

Table 19 Program space page index

PIX5	PIX4	PIX3	PIX2	PIX1	PIX0	Program Space Selected
1	1	0	1	1	0	16K Flash EEPROM Page \$36
1	1	0	1	1	1	16K Flash EEPROM Page \$37
1	1	1	0	0	0	16K Flash EEPROM Page \$38
1	1	1	0	0	1	16K Flash EEPROM Page \$39
1	1	1	0	1	0	16K Flash EEPROM Page \$3A
1	1	1	0	1	1	16K Flash EEPROM Page \$3B
1	1	1	1	0	0	16K Flash EEPROM Page \$3C
1	1	1	1	0	1	16K Flash EEPROM Page \$3D
1	1	1	1	1	0	16K Flash EEPROM Page \$3E
1	1	1	1	1	1	16K Flash EEPROM Page \$3F

NOTE: *In single chip mode pages are mirrored in the address map, i.e. page \$30 occurs also as \$00, \$10 and \$20. However it is advised that the user does not make use of this in order to stay compatible with future derivatives.*

PARTIDH — Part ID Register High

Address Offset: \$001A

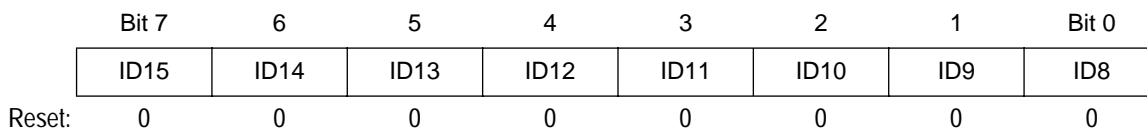

PARTIDL — Part ID Register High

Address Offset: \$001B

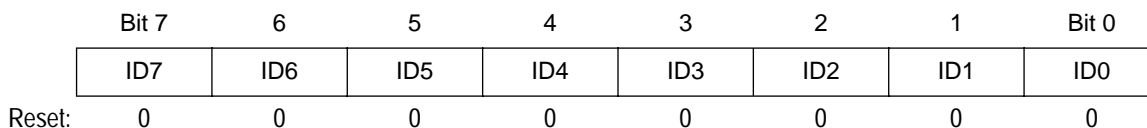

This register is used to designate the part ID. Each revision of the chip will have a unique value in the contents of this register.

Read anytime.

Write never.

Miscellaneous System Control Register

Additional mapping and external resource controls are available. To use external resources the part must be operated in one of the expanded modes.

MISC — Miscellaneous Mapping Control Register

Address Offset: \$0013

	Bit 7	6	5	4	3	2	1	Bit 0	Mode
	0	0	0	0	EXSTR1	EXSTR0	ROMHM	ROMON	
Reset:	0	0	0	0	1	1	0	(1)	Exp mode
Reset:	0	0	0	0	1	1	0	1	peripheral or SC mode

1. in expanded modes the reset value of ROMON is determined by the value present on the PK7 pin during reset.

EXSTR1, EXSTR0 — External Access Stretch

This two bit field determines the amount of clock stretch on accesses to the external address space. In single chip and peripheral modes these bits have no meaning or effect.

In emulation modes (wide or narrow), accesses to addresses that are normally internal but are removed from the memory map will take place in one cycle, regardless of the state of the EXSTR[1:0] bits. These addresses include the following register locations: PORTA, PORTB, DDRA, DDRB, PORTE, DDRE, PEAR, MODE, PUCR, RDRIV, PORTK and DDRK. They also include the following Flash space addresses: \$4000–\$7FFF (but only if ROMHM = 0) and \$8000 – \$FFFF.

Normal and Emulation: Write once.

Special: Write anytime.

Table 20 EXSTR Stretch Bit Definition

Stretch bit EXSTR1	Stretch bit EXSTR0	Number of E Clocks Stretched
0	0	0
0	1	1
1	0	2
1	1	3

ROMHM — Flash EEPROM only in second half of memory map

1 = Disables direct access to the 16K byte Flash EEPROM in location \$4000 – \$7FFF in the memory map. The physical location of this 16K byte Flash can still be accessed through the Program Page window.

0 = The 16K byte Page \$3E (62) of fixed Flash EEPROM in location \$4000 – \$7FFF can be accessed.

ROMON — Enable Flash EEPROM

This bit is used to enable the Flash EEPROM memory in the memory map. In expanded modes, the reset state of this bit is determined by the state of the port K bit 7 pin during reset.

Normal and Emulation: Write once.

Special: Write anytime.

1 = Enables the Flash EEPROM in the memory map.

0 = Disables the Flash EEPROM from the memory map.

Memory Maps

The following diagrams illustrate the memory map for each mode of operation immediately after reset.

Resource Mapping

Freescale Semiconductor, Inc.

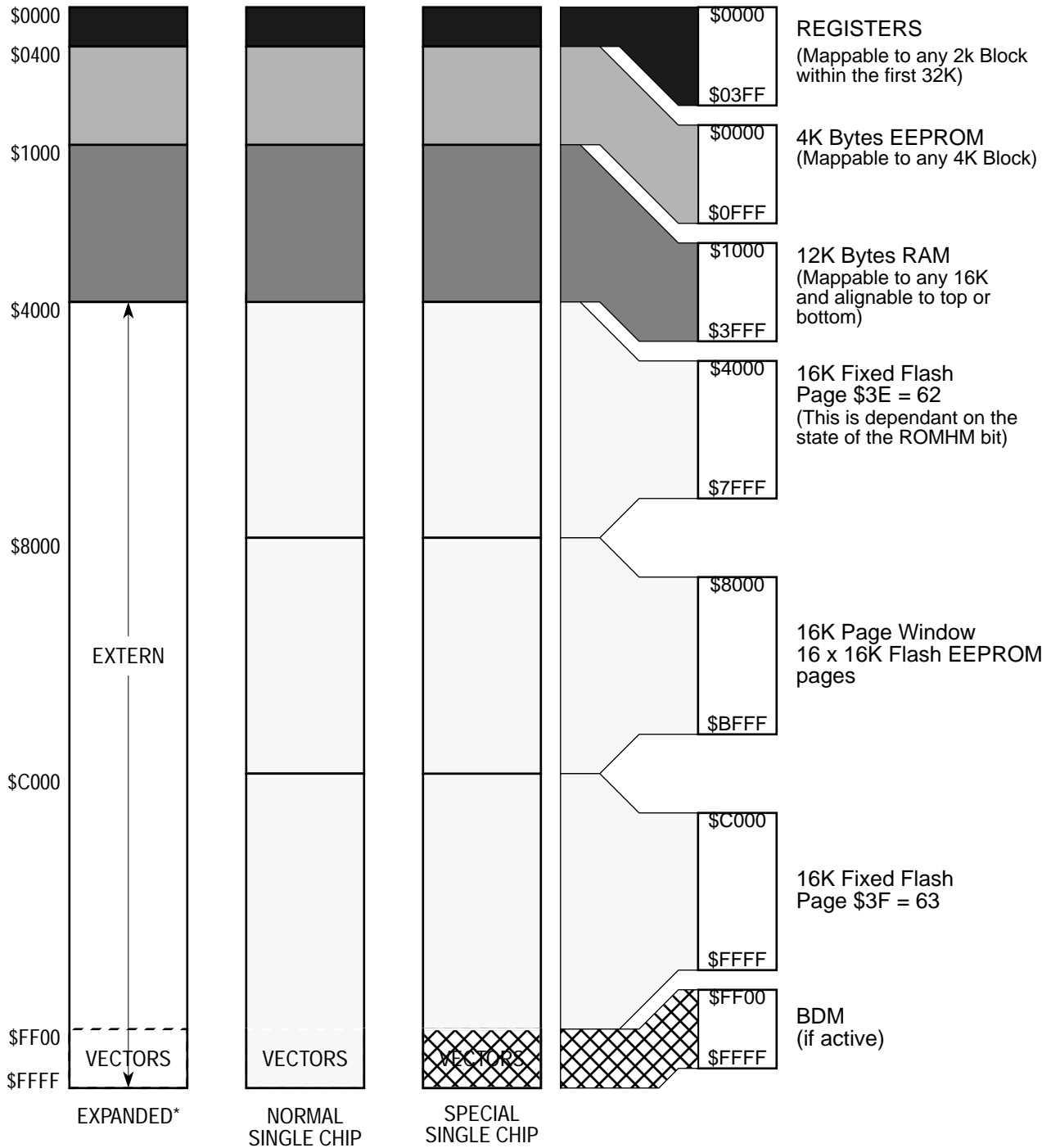

* Assuming that a '0' was driven onto port K bit 7 during reset.

Figure 8 MC9S12DP256 Memory Map after reset

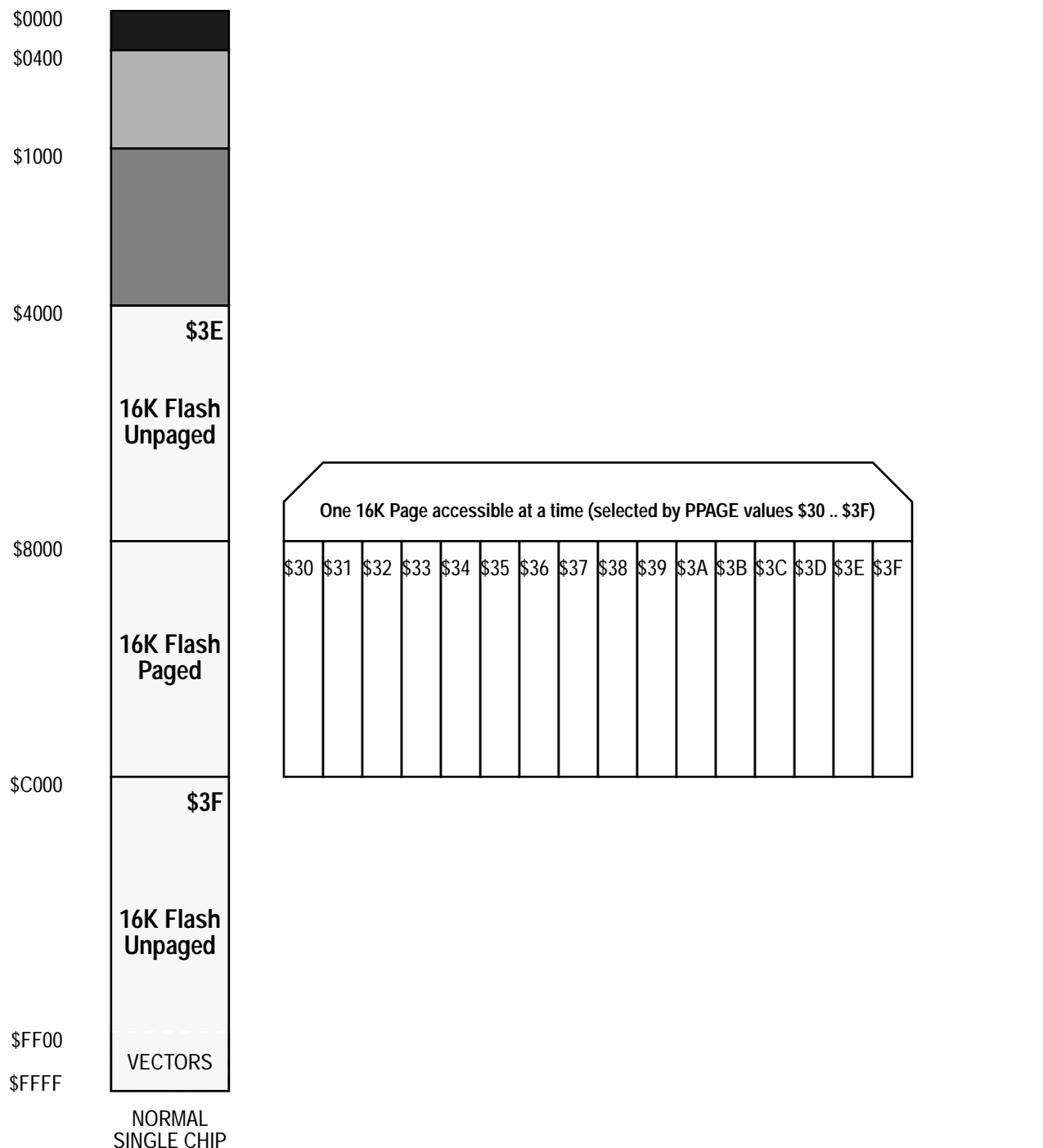

Figure 9 MC9S12DP256 Memory Paging



Bus Control and Input/Output

Contents

Introduction	123
Detecting Access Type from External Signals	123
Stretched Bus Cycles	124
PIPE Status Signals	125
Registers	127

Introduction

Internally the MC9S12DP256 has full 16-bit data paths, but depending upon the operating mode and control registers, the external multiplexed bus may be 8 or 16 bits. There are cases where 8-bit and 16-bit accesses can appear on adjacent cycles using the $\overline{\text{LSTRB}}$ signal to indicate 8- or 16-bit data.

Detecting Access Type from External Signals

The external signals $\overline{\text{LSTRB}}$, $\overline{\text{R}/\overline{\text{W}}}$, and A0 indicate the type of bus access that is taking place. Accesses to the internal RAM module are the only type of access that produce $\overline{\text{LSTRB}} = \text{A0} = 1$, because the internal RAM is specifically designed to allow misaligned 16-bit accesses in a single cycle. In these cases the data for the address that was accessed is on the low half of the data bus and the data for address + 1 is on the high half of the data bus.

Table 21 Access Type vs. Bus Control Pins

LSTRB	A0	R/W	Type of Access
1	0	1	8-bit read of an even address
0	1	1	8-bit read of an odd address
1	0	0	8-bit write of an even address
0	1	0	8-bit write of an odd address
0	0	1	16-bit read of an even address
1	1	1	16-bit read of an odd address (low/high data swapped)
0	0	0	16-bit write to an even address
1	1	0	16-bit write to an odd address (low/high data swapped)

Stretched Bus Cycles

In order to allow fast internal bus cycles to coexist in a system with slower external memory resources, the STAR12 supports the concept of stretched bus cycles (module timing reference clocks for timers and baud rate generators are not affected by this stretching). Control registers specify the amount of stretch (0, 1, 2, or 3 periods of the internal bus-rate clock). While stretching, the CPU clocks are halted during the E clock high period of an unstretched bus cycle. At this point in the CPU bus cycle, write data would already be driven onto the data bus so the length of time write data is valid is extended in the case of a stretched bus cycle. Read data would not be captured by the MCU until the E clock falling edge. In the case of a stretched bus cycle, read data is not required until the specified setup time before the falling edge of the stretched E clock. The external address and R/W signals remain valid during the period of stretching (throughout the stretched E high time).

PIPE Status Signals

PIPE status signals IPIPE[1:0] provide information about data movement in the queue and indicate when the CPU begins to execute instructions. This makes it possible to monitor CPU activity on a cycle-by-cycle basis for debugging. Information available on the IPIPE[1:0] pins is time multiplexed.

Data movement (valid during E-clock high) is represented by two states:

- Advance and load from bus – This state means the queue shifts up one stage with stage 1 being filled with the instruction on the bus.
- No movement – This state means there is no data shifting in the queue.

The execution start (valid during E-clock low) is represented by four states:

- No start – This state indicates a continuation of the current instruction.
- Start interrupt – This state indicates that an interrupt sequence has begun.

NOTE: The start interrupt state is indicated when an external signal alters program flow (i.e. interrupt request, force or tag). SWI and TRAP instructions in the instruction pipe are indicated as start even or start odd depending on their alignment. In this case, the SWI and TRAP instructions are part of the normal program flow. Since they are present in the queue, they may be tracked in an external pipe rebuild. An external event that interrupts program flow is indeterministic. Program data is not present in the queue until after the vector jump.

- Start even – This state indicates the current opcode is located in the top of the queue, high byte.

- Start odd – This state indicates the current opcode is located in the top of the queue, low byte.

Table 22 Pipe Status Signals IPIPE[1:0], E Clock High

Data Movement	Mnemonic	Meaning
0:0	–	No movement
1:0	ALD	Advance queue, load from bus

Table 23 Pipe Status Signals IPIPE[1:0], E Clock Low

Execution Start	Mnemonic	Meaning
0:0	–	No start
0:1	INT	Start interrupt sequence
1:0	SEV	Start even instruction
1:1	SOD	Start odd instruction

The MEBI sub-block modifies the CPU pipe signals on cycles that are not controlled by the CPU so that an external development system can interpret the status information in a consistent way. The modification forces 0:0 indications on the external pipe signals on Port E, bits 6 and 5 during the extra external E clock edges when the CPU clock is stopped.

Four types of bus accesses cause an interruption to the normal flow of this information. The first case is called a bus steal which is caused when another module has to steal a bus cycle (i.e. BDM access). The second case is called a hold which is caused when another module needs to stop the cycle (i.e. splitting a 16-bit access into two separate 8-bit accesses or a stretch cycle to accommodate a slow memory access). The CPU clocks are stopped during these accesses. The last cases are combinations of hold followed by bus steal or bus steal followed by hold. During these accesses, the internal bus clock is free running.

Registers

Not all registers are visible in the MC9S12DP256 memory map under certain conditions.

In special peripheral mode the first 16 registers associated with bus expansion are removed from the memory map.

In expanded modes, some or all of port A, port B, and port E are used for expansion buses and control signals. In order to allow emulation of the single-chip functions of these ports, some of these registers must be rebuilt in an external port replacement unit. In any expanded mode, port A, and port B, are used for address and data lines so registers for these ports, as well as the data direction registers for these ports, are removed from the on-chip memory map and become external accesses.

In any expanded mode, port E pins may be needed for bus control (e.g., ECLK, R/\overline{W}). To regain the single-chip functions of port E, the emulate port E (EME) control bit in the MODE register may be set. In this special case of expanded mode and EME set, PORTE and DDRE registers are removed from the on-chip memory map and become external accesses so port E may be rebuilt externally.

Bus Control and Input/Output

PORTA — Port A Register

Address Offset: \$0000

	Bit 7	6	5	4	3	2	1	Bit 0
Single Chip	BIT 7	6	5	4	3	2	1	BIT 0
Reset:	Unaffected by reset							
Expanded & Periph:	ADDR15/ DATA15	ADDR14/ DATA14	ADDR13/ DATA13	ADDR12/ DATA12	ADDR11/ DATA11	ADDR10/ DATA10	ADDR9/ DATA9	ADDR8/ DATA8
Expanded narrow	ADDR15/ DATA15/ DATA7	ADDR14/ DATA14/ DATA6	ADDR13/ DATA13/ DATA5	ADDR12/ DATA12/ DATA4	ADDR11/ DATA11/ DATA3	ADDR10/ DATA10/ DATA2	ADDR9/ DATA9/ DATA1	ADDR8/ DATA8/ DATA0

Port A bits 7 through 0 are associated with address lines A15 through A8 respectively and data lines D15/D7 through D8/D0 respectively. When this port is not used for external addresses such as in single-chip mode, these pins can be used as general purpose I/O. Data Direction Register A (DDRA) determines the primary direction of each pin. DDRA also determines the source of data for a read of PORTA.

This register is not in the on-chip map in expanded and peripheral modes.

CAUTION: *To ensure that you read the value present on the PORTA pins, always wait at least two cycles after writing to the DDRA register before reading from the PORTA register.*

Read and write: anytime (provided this register is in the map).

DDRA — Port A Data Direction Register

Address Offset: \$0002

	Bit 7	6	5	4	3	2	1	Bit 0
	BIT 7	6	5	4	3	2	1	BIT 0
Reset:	0	0	0	0	0	0	0	0

This register controls the data direction for Port A. When Port A is operating as a general purpose I/O port, DDRA determines the primary direction for each Port A pin. A “1” causes the associated port pin to be an output and a “0” causes the associated pin to be a high-impedance input. The value in a DDR bit also affects the source of data for reads of the corresponding PORTA register. If the DDR bit is zero (input) the buffered pin input is read. If the DDR bit is one (output) the output of the port data latch is read.

This register is not in the on-chip map in expanded and peripheral modes. It is reset to \$00 so the DDR does not override the three-state control signals.

Read and write: anytime (provided this register is in the map).

DDRA7–0 — Data Direction Port A

- 0 = Configure the corresponding I/O pin as an input
- 1 = Configure the corresponding I/O as an output

PORTB — Port B Register

Address Offset: \$0001

	Bit 7	6	5	4	3	2	1	Bit 0
Single Chip	Bit 7	6	5	4	3	2	1	Bit 0
Reset:	Unaffected by reset							
Expanded & Periph:	ADDR7/ DATA7	ADDR6/ DATA6	ADDR5/ DATA5	ADDR4/ DATA4	ADDR3/ DATA3	ADDR2/ DATA2	ADDR1/ DATA1	ADDR0/ DATA0
Expanded narrow	ADDR7	ADDR6	ADDR5	ADDR4	ADDR3	ADDR2	ADDR1	ADDR0

Port B bits 7 through 0 are associated with address lines A7 through A0 respectively and data lines D7 through D0 respectively. When this port is not used for external addresses, such as in single-chip mode,

these pins can be used as general purpose I/O. Data Direction Register B (DDRB) determines the primary direction of each pin. DDRB also determines the source of data for a read of PORTB.

This register is not in the on-chip map in expanded and peripheral modes.

CAUTION: *To ensure that you read the value present on the PORTB pins, always wait at least two cycles after writing to the DDRB register before reading from the PORTB register.*

Read and write: anytime (provided this register is in the map).

DDRB — Port B Data Direction Register

Address Offset: \$0003

	Bit 7	6	5	4	3	2	1	Bit 0
	Bit 7	6	5	4	3	2	1	Bit 0
Reset:	0	0	0	0	0	0	0	0

This register controls the data direction for Port B. When Port B is operating as a general purpose I/O port, DDRB determines the primary direction for each Port B pin. A “1” causes the associated port pin to be an output and a “0” causes the associated pin to be a high-impedance input. The value in a DDR bit also affects the source of data for reads of the corresponding PORTB register. If the DDR bit is zero (input) the buffered pin input is read. If the DDR bit is one (output) the output of the port data latch is read.

This register is not in the on-chip map in expanded and peripheral modes. It is reset to \$00 so the DDR does not override the three-state control signals.

Read and write: anytime (provided this register is in the map).

DDRB7–0 — Data Direction Port B

- 0 = Configure the corresponding I/O pin as an input
- 1 = Configure the corresponding I/O pin as an output

Bus Control and Input/Output
PORTE — Port E Register

Address Offset: \$0008

	Bit 7	6	5	4	3	2	1	Bit 0
	Bit 7	6	5	4	3	2	1	Bit 0
Reset:				Unaffected by reset				
Alt. Pin Function	\overline{XCLKS} or NOACC	MODB or IPIPE1 or SCGTO	MODA or IPIPE0 or RCRT0	ECLK	\overline{LSTRB} or \overline{TAGLO}	R/W	\overline{IRQ}	\overline{XIRQ}

Port E is associated with external bus control signals and interrupt inputs. These include mode select ($\overline{XCLKS}/NOACC$, MODB/IPIPE1, MODA/IPIPE0), E clock, size ($\overline{LSTRB}/\overline{TAGLO}$), read / write (R/W), \overline{IRQ} , and \overline{XIRQ} . When the associated pin is not used for one of these specific functions, the pin can be used as general purpose I/O. The Port E Assignment Register (PEAR) selects the function of each pin and DDRE determines whether each pin is an input or output when it is configured to be general purpose I/O. DDRE also determines the source of data for a read of PORTE.

Some of these pins have software selectable pullups (PE7, ECLK, \overline{LSTRB} , R/W, \overline{IRQ} and \overline{XIRQ}). A single control bit enables the pullups for all of these pins when they are configured as inputs.

This register is not in the on-chip map in peripheral mode or in expanded modes when the EME bit is set.

Read and write: anytime (provided this register is in the map).

CAUTION: *It is unwise to write PORTE and DRRE as a word access. If you are changing PORT E pins from being inputs to outputs, the data may have extra transitions during the write. It is best to initialize PORTE before enabling as outputs.*

CAUTION: *To ensure that you read the value present on the PORTE pins, always wait at least two cycles after writing to the DDRE register before reading from the PORTE register.*

DDRE — Port E Data Direction Register

Address Offset: \$0009

	Bit 7	6	5	4	3	2	1	Bit 0
	Bit 7	6	5	4	3	Bit 2	0	0
Reset:	0	0	0	0	0	0	0	0

Data Direction Register E is associated with Port E. For bits in Port E that are configured as general purpose I/O lines, DDRE determines the primary direction of each of these pins. A “1” causes the associated bit to be an output and a “0” causes the associated bit to be an input. Port E bit 1 (associated with \overline{IRQ}) and bit 0 (associated with \overline{XIRQ}) cannot be configured as outputs. Port E, bit 1, and bit 0 can be read regardless of whether the alternate interrupt function is enabled. The value in a DDR bit also affects the source of data for reads of the corresponding PORTE register. If the DDR bit is zero (input) the buffered pin input is read. If the DDR bit is one (output) the output of the port data latch is read.

This register is not in the on-chip map in peripheral mode. It is also not in the map in expanded modes while the EME control bit is set.

Read and write: anytime (provided this register is in the map).

DDRE7–2 — Data Direction Port E

- 0 = Configure the corresponding I/O pin as an input
- 1 = Configure the corresponding I/O pin as an output

Bus Control and Input/Output
PEAR — Port E Assignment Register

Address Offset: \$000A

	Bit 7	6	5	4	3	2	1	Bit 0	
	NOACCE	0	PIPOE	NECLK	LSTRE	RDWE	0	0	
Reset:	0	0	0	0	0	0	0	0	Special single chip
Reset:	0	0	1	0	1	1	0	0	Special Test
Reset:	0	0	0	0	0	0	0	0	Peripheral
Reset:	1	0	1	0	1	1	0	0	Emulation Exp Nar
Reset:	1	0	1	0	1	1	0	0	Emulation Exp Wide
Reset:	0	0	0	1	0	0	0	0	Normal Single Chip
Reset:	0	0	0	0	0	0	0	0	Normal Exp Nar
Reset:	0	0	0	0	0	0	0	0	Normal Exp Wide

Port E serves as general purpose I/O lines or as system and bus control signals. The PEAR register is used to choose between the general-purpose I/O functions and the alternate bus control functions. When an alternate control function is selected, the associated DDRE bits are overridden.

The reset condition of this register depends on the mode of operation because bus control signals are needed immediately after reset in some modes.

In normal single chip mode, no external bus control signals are needed so all of Port E is configured for general purpose I/O.

In normal expanded modes, only the E clock is configured for its alternate bus control function and the other bits of Port E are configured for general purpose I/O. As the reset vector is located in external memory, the E clock is required for this access. $R\overline{W}$ is only needed by the system when there are external writable resources. If the normal expanded system needs any other bus control signals, PEAR would need to be written before any access that needed the additional signals.

In special test and emulation modes, IPIPE1, IPIPE0, E, \overline{LSTRB} and $R\overline{W}$ are configured out of reset as bus control signals.

NOACCE — CPU No Access Output Enable

Normal: write once

Emulation: write never

Special: write anytime

1 = The associated pin (Port E bit 7) is output and indicates whether the cycle is a CPU free cycle.

0 = The associated pin (Port E bit 7) is general purpose I/O.

This bit has no effect in single chip or peripheral modes.

PIPOE — Pipe Status Signal Output Enable

Normal: write once

Emulation: write never

Special: write anytime.

1 = The associated pins (Port E bits 6:5) are outputs and indicate the state of the instruction queue

0 = The associated pins (Port E bits 6:5) are general purpose I/O.

This bit has no effect in single chip or peripheral modes.

NECLK — No External E Clock

Normal and Special: write anytime

Emulation: write never

1 = The associated pin (Port E bit 4) is a general purpose I/O pin.

0 = The associated pin (Port E bit 4) is the external E clock pin.

External E clock is free-running if ESTR=0.

External E clock is available as an output in all modes.

LSTRE — Low Strobe ($\overline{\text{LSTRB}}$) Enable

Normal: write once

Emulation: write never

Special: write anytime.

1 = The associated pin (Port E bit 3) is configured as the $\overline{\text{LSTRB}}$ bus control output. If BDM tagging is enabled, $\overline{\text{TAGLO}}$ is multiplexed in on the data cycle and $\overline{\text{LSTRB}}$ is driven out on the address cycle.

0 = The associated pin (Port E bit 3) is a general purpose I/O pin.

This bit has no effect in single chip, peripheral or normal expanded narrow modes.

NOTE: $\overline{\text{LSTRB}}$ is used during external writes. After reset in normal expanded mode, $\overline{\text{LSTRB}}$ is disabled to provide an extra I/O pin. If $\overline{\text{LSTRB}}$ is needed, it should be enabled before any external writes. External reads do not normally need $\overline{\text{LSTRB}}$ because all 16 data bits can be driven even if the MCU only needs 8 bits of data

RDWE — Read / Write Enable

Normal: write once

Emulation: write never

Special: write anytime

1 = The associated pin (Port E bit 2) is configured as the $R\overline{W}$ pin.

0 = The associated pin (Port E bit 2) is a general purpose I/O pin.

This bit has no effect in single chip or peripheral modes.

NOTE: $R\overline{W}$ is used for external writes. After reset in normal expanded mode, $R\overline{W}$ is disabled to provide an extra I/O pin. If $R\overline{W}$ is needed it should be enabled before any external writes.

PUCR — Pull-Up Control Register

Address Offset: \$000C

	Bit 7	6	5	4	3	2	1	Bit 0
	PUPKE	0	0	PUPEE	0	0	PUPBE	PUPAE
Reset:	1	0	0	1	0	0	0	0

This register is used to select pullup resistors for the pins associated with the A, B, E, K ports. Pullups are assigned on a per-port basis and apply to any pin in the corresponding port that is currently configured as an input.

This register is not in the on-chip map in emulation and peripheral modes.

Read and write: anytime (provided this register is in the map).

PUPKE — Pull-Up Port K Enable

0 = Port K pull-ups are disabled.

1 = Enable pull-up devices for port K input pins.

PUPEE — Pull-Up Port E Enable

0 = Port E pull-ups on bit 7, 4–0 are disabled.

1 = Enable pull-up devices for port E input pin bits 7, 4–0.

PUPBE — Pull-Up Port B Enable

0 = Port B pull-ups are disabled.

1 = Enable pull-up devices for all port B input pins.

PUPAE — Pull-Up Port A Enable

0 = Port A pull-ups are disabled.

1 = Enable pull-up devices for all port A input pins.

Bus Control and Input/Output

RDRIV — Reduced Drive of I/O Lines

Address Offset: \$000D

	Bit 7	6	5	4	3	2	1	Bit 0
	RDPK	0	0	RDPE	0	0	RDPB	RDPA
Reset:	0	0	0	0	0	0	0	0

This register is used to select reduced drive for the pins associated with the A, B, E, K ports. This gives reduced power consumption and reduced RFI with a slight increase in transition time (depending on loading). This feature would be used on ports which have a light loading. The reduced drive function is independent of which function is being used on a particular port.

This register is not in the on-chip map in emulation and peripheral modes.

Read and write: anytime (provided this register is in the map).

RDPK — Reduced Drive of Port K

- 0 = All port K output pins have full drive enabled.
- 1 = All port K output pins have reduced drive enabled.

RDPE — Reduced Drive of Port E

- 0 = All port E output pins have full drive enabled.
- 1 = All port E output pins have reduced drive enabled.

RDPB — Reduced Drive of Port B

- 0 = All port B output pins have full drive enabled.
- 1 = All port B output pins have reduced drive enabled.

RDPA — Reduced Drive of Port A

- 0 = All port A output pins have full drive enabled.
- 1 = All port A output pins have reduced drive enabled.

EBICTL — External Bus Interface Control

Address Offset: \$000E

	Bit 7	6	5	4	3	2	1	Bit 0	
	0	0	0	0	0	0	0	ESTR	
Reset:	0	0	0	0	0	0	0	0	Peripheral
Reset:	0	0	0	0	0	0	0	1	All other modes

The EBICTL register is used to control miscellaneous functions (i.e. stretching of external E clock).

This register is not in the on-chip map in peripheral mode.

Read: anytime (provided this register is in the map).

ESTR — E Stretches

This control bit determines whether the E clock behaves as a simple free-running clock or as a bus control signal that is active only for external bus cycles.

Normal and Emulation: write once

Special: write anytime

1 = E stretches high during stretch cycles and low during non-visible internal accesses.

0 = E never stretches (always free running).

This bit has no effect in single chip modes.



Resets and Interrupts

Contents

Introduction	141
Register Map	142
Exception Priority	142
Maskable interrupts	143
Latching of Interrupts	144
Register Descriptions	147
Resets	151
Effects of Reset	155
Register Stacking	157

Introduction

STAR12 exceptions include resets and interrupts. Each exception has an associated 16-bit vector, which points to the memory location where the routine that handles the exception is located. Vectors are stored in the upper 128 bytes of the standard 64K byte address map.

The six highest vector addresses are used for resets and non-maskable interrupt sources. The remainder of the vectors are used for maskable interrupts, and all must be initialized to point to the address of the appropriate service routine.

Resets and Interrupts

Register Map

Address	Register Name	Bit 7	6	5	4	3	2	1	Bit 0	
\$0015	ITCR	Read:	0	0	0	WRTINT	ADR3	ADR2	ADR1	ADR0
		Write:								
\$0016	ITEST	Read:	INTE	INTC	INTA	INT8	INT6	INT4	INT2	INT0
		Write:								
\$001E	INTCR	Read:	IRQE	IROEN	0	0	0	0	0	0
		Write:								
\$001F	HPRIO	Read:	PSEL7	PSEL6	PSEL5	PSEL4	PSEL3	PSEL2	PSEL1	0
		Write:								

= Reserved or unimplemented

Figure 10 Resets and Interrupts Register Map

Exception Priority

A hardware priority hierarchy determines which reset or interrupt is serviced first when simultaneous requests are made. Six sources are not maskable. The remaining sources are maskable, and any one of them can be given priority over other maskable interrupts.

The priorities of the non-maskable sources are:

1. POR or $\overline{\text{RESET}}$ pin
2. Clock monitor reset
3. COP watchdog reset
4. Unimplemented instruction trap
5. Software interrupt instruction (SWI)
6. $\overline{\text{XIRQ}}$ signal (if X bit in CCR = 0)

Maskable interrupts

Maskable interrupt sources include on-chip peripheral systems and external interrupt service requests. Interrupts from these sources are recognized when the global interrupt mask bit (I) in the CCR is cleared. The default state of the I bit out of reset is one, but it can be written at any time.

Interrupt sources are prioritized by default but any one maskable interrupt source may be assigned the highest priority by means of the HPRIO register. The relative priorities of the other sources remain the same.

An interrupt that is assigned highest priority is still subject to global masking by the I bit in the CCR, or by any associated local bits. Interrupt vectors are not affected by priority assignment. HPRIO can only be written while the I bit is set (interrupts inhibited). [Table 24](#) lists interrupt sources and vectors in default order of priority. Before masking an interrupt by clearing the corresponding local enable bit, it is required to set the I-bit to avoid an SWI.

Latching of Interrupts

\overline{XIRQ} is always level triggered and \overline{IRQ} can be selected as a level triggered interrupt. These level triggered interrupt pins should only be released during the appropriate interrupt service routine. Generally the interrupt service routine will handshake with the interrupting logic to release the pin. In this way, the MCU will never start the interrupt service sequence only to determine that there is no longer an interrupt source. In event that this does occur the trap vector will be taken.

If \overline{IRQ} is selected as an edge triggered interrupt, the hold time of the level after the active edge is independent of when the interrupt is serviced. As long as the minimum hold time is met, the interrupt will be latched inside the MCU. In this case the \overline{IRQ} edge interrupt latch is cleared automatically when the interrupt is serviced.

All of the remaining interrupts are latched by the MCU with a flag bit. These interrupt flags should be cleared during an interrupt service routine or when interrupts are masked by the I bit. By doing this, the MCU will never get an unknown interrupt source and take the trap vector.

Table 24 Interrupt Vector Table

Vector Address	Interrupt Source	CCR Mask	Local Enable	HPRIO Value to Elevate
\$FFFE, \$FFFF	Reset	None	None	–
\$FFFC, \$FFFD	Clock Monitor fail reset	None	COPCTL (CME, FCME)	–
\$FFFA, \$FFFB	COP failure reset	None	COP rate select	–
\$FFF8, \$FFF9	Unimplemented instruction trap	None	None	–
\$FFF6, \$FFF7	SWI	None	None	–
\$FFF4, \$FFF5	XIRQ	X-Bit	None	–
\$FFF2, \$FFF3	IRQ	I-Bit	INTCR (IRQEN)	\$F2
\$FFF0, \$FFF1	Real Time Interrupt	I-Bit	CRGINT (RTIE)	\$F0
\$FFEE, \$FFEF	Timer channel 0	I-Bit	TMSK1 (C0I)	\$EE
\$FFEC, \$FFED	Timer channel 1	I-Bit	TMSK1 (C1I)	\$EC
\$FFEA, \$FFEB	Timer channel 2	I-Bit	TMSK1 (C2I)	\$EA
\$FFE8, \$FFE9	Timer channel 3	I-Bit	TMSK1 (C3I)	\$E8
\$FFE6, \$FFE7	Timer channel 4	I-Bit	TMSK1 (C4I)	\$E6

Table 24 Interrupt Vector Table

\$FFE4, \$FFE5	Timer channel 5	I-Bit	TMSK1 (C5I)	\$E4
\$FFE2, \$FFE3	Timer channel 6	I-Bit	TMSK1 (C6I)	\$E2
\$FFE0, \$FFE1	Timer channel 7	I-Bit	TMSK1 (C7I)	\$E0
\$FFDE, \$FFDF	Timer overflow	I-Bit	TMSK2 (TOI)	\$DE
\$FFDC, \$FFDD	Pulse accumulator A overflow	I-Bit	PACTL (PAOVI)	\$DC
\$FFDA, \$FFDB	Pulse accumulator input edge	I-Bit	PACTL (PAI)	\$DA
\$FFD8, \$FFD9	SPI0	I-Bit	SP0CR1 (SPIE, SPTIE)	\$D8
\$FFD6, \$FFD7	SCI 0	I-Bit	SC0CR2 (TIE, TCIE, RIE, ILIE)	\$D6
\$FFD4, \$FFD5	SCI 1	I-Bit	SC1CR2 (TIE, TCIE, RIE, ILIE)	\$D4
\$FFD2, \$FFD3	ATD0	I-Bit	ATDOCTL2 (ASCIE)	\$D2
\$FFD0, \$FFD1	ATD1	I-Bit	ATD1CTL2 (ASCIE)	\$D0
\$FFCE, \$FFCF	Port J	I-Bit	PTJIF (PTJIE)	\$CE
\$FFCC, \$FFCD	Port H	I-Bit	PTHIF(PTHIE)	\$CC
\$FFCA, \$FFCB	Modulus Down Counter underflow	I-Bit	MCCTL(MCZI)	\$CA
\$FFC8, \$FFC9	Pulse Accumulator B Overflow	I-Bit	PBCTL(PBOVI)	\$C8
\$FFC6, \$FFC7	CRG lock	I-Bit	PLLCR(LOCKIE)	\$C6
\$FFC4, \$FFC5	SCME	I-Bit	PLLCR (SCMIE)	\$C4
\$FFC2, \$FFC3	DLC	I-Bit	DLCBCR1(IE)	\$C2
\$FFC0, \$FFC1	IIC Bus	I-Bit	IBCR (IBIE)	\$C0
\$FFBE, \$FFBF	SPI1	I-Bit	SP1CR1 (SPIE, SPTIE)	\$BE
\$FFBC, \$FFBD	SPI2	I-Bit	SP2CR1 (SPIE, SPTIE)	\$BC
\$FFBA, \$FFBB	EEPROM	I-Bit	EECTL(CCIE, CBEIE)	\$BA
\$FFB8, \$FFB9	FLASH	I-Bit	FCTL(CCIE, CBEIE)	\$B8
\$FFB6, \$FFB7	MSCAN 0 wake-up	I-Bit	C0RIER (WUPIE)	\$B6
\$FFB4, \$FFB5	MSCAN 0 errors	I-Bit	C0RIER (RWRNIE, TWRNIE, RERRIE, TERRE, BOFFIE, OVRIE)	\$B4
\$FFB2, \$FFB3	MSCAN 0 receive	I-Bit	C0RIER (RXFIE)	\$B2
\$FFB0, \$FFB1	MSCAN 0 transmit	I-Bit	C0TIER(TXEIE[2:0])	\$B0
\$FFAE, \$FFAF	MSCAN 1 wake-up	I-Bit	C1RIER (WUPIE)	\$AE
\$FFAC, \$FFAD	MSCAN 1 errors	I-Bit	C1RIER (RWRNIE, TWRNIE, RERRIE, TERRE, BOFFIE, OVRIE)	\$AC
\$FFAA, \$FFAB	MSCAN 1 receive	I-Bit	C1RIER (RXFIE)	\$AA
\$FFA8, \$FFA9	MSCAN 1 transmit	I-Bit	C1TIER(TXEIE[2:0])	\$A8
\$FFA6, \$FFA7	MSCAN 2 wake-up	I-Bit	C2RIER (WUPIE)	\$A6

Table 24 Interrupt Vector Table

\$FFA4, \$FFA5	MSCAN 2 errors	I-Bit	C2RIER (RWRNIE, TWRNIE, RERRIE, TERRE, BOFFIE, OVRIE)	\$A4
\$FFA2, \$FFA3	MSCAN 2 receive	I-Bit	C2RIER (RXFIE)	\$A2
\$FFA0, \$FFA1	MSCAN 2 transmit	I-Bit	C2TIER(TXEIE[2:0])	\$A0
\$FF9E, \$FF9F	MSCAN 3 wake-up	I-Bit	C3RIER (WUPIE)	\$9E
\$FF9C, \$FF9D	MSCAN 3 errors	I-Bit	C3RIER (RWRNIE, TWRNIE, RERRIE, TERRE, BOFFIE, OVRIE)	\$9C
\$FF9A, \$FF9B	MSCAN 3 receive	I-Bit	C3RIER (RXFIE)	\$9A
\$FF98, \$FF99	MSCAN 3 transmit	I-Bit	C3TIER(TXEIE[2:0])	\$98
\$FF96, \$FF97	MSCAN 4 wake-up	I-Bit	C4RIER (WUPIE)	\$96
\$FF94, \$FF95	MSCAN 4 errors	I-Bit	C4RIER (RWRNIE, TWRNIE, RERRIE, TERRE, BOFFIE, OVRIE)	\$94
\$FF92, \$FF93	MSCAN 4 receive	I-Bit	C4RIER (RXFIE)	\$92
\$FF90, \$FF91	MSCAN 4 transmit	I-Bit	C4TIER(TXEIE[2:0])	\$90
\$FF8E, \$FF8F	Port P Interrupt	I-Bit	PTPIF(PTPIE)	\$8E
\$FF8C, \$FF8D	PWM Emergency Shutdown	I-Bit	PWMSDN(PWMIE)	\$8C
\$FF8A, \$FF8B	INT8A reserved for future use	I-Bit		\$8A
\$FF88, \$FF89	INT88 reserved for future use	I-Bit		\$88
\$FF86, \$FF87	INT86 reserved for future use	I-Bit		\$86
\$FF84, \$FF85	INT84 reserved for future use	I-Bit		\$84
\$FF82, \$FF83	INT82 reserved for future use	I-Bit		\$82
\$FF80, \$FF81	INT80 reserved for future use	I-Bit		\$80

Register Descriptions

Interrupt Control and Priority Register

INTCR — Interrupt Control Register

Address Offset: \$001E

	Bit 7	6	5	4	3	2	1	Bit 0
	IRQE	IRQEN	0	0	0	0	0	0
Reset:	0	1	0	0	0	0	0	0

IRQE — IRQ Select Edge Sensitive Only

- 1 = IRQ configured to respond only to falling edges. Falling edges on the IRQ pin will be detected anytime IRQE = 1 and will be cleared only upon a reset or the servicing of the IRQ interrupt.
- 0 = IRQ configured for low-level recognition.

Special: read or write anytime

Normal: read anytime, write once

Emulation: read anytime, write never

IRQEN — External IRQ Enable

- 1 = External $\overline{\text{IRQ}}$ pin is connected to interrupt logic.
- 0 = External $\overline{\text{IRQ}}$ pin is disconnected from interrupt logic.

Normal, emulation, and special modes: read or write anytime

Resets and Interrupts

HPRIO — Highest Priority I Interrupt

Address Offset: \$001F

	Bit 7	6	5	4	3	2	1	Bit 0
	PSEL7	PSEL6	PSEL5	PSEL4	PSEL3	PSEL2	PSEL1	0
Reset:	1	1	1	1	0	0	1	0

Determines which I maskable interrupt will be promoted to highest priority (of the I maskable interrupts). To promote an interrupt the user writes the least significant byte of the associated interrupt vector address to this register. If an unimplemented vector address or a non I-masked vector address (value higher than \$F2) is written, then FFF2 will be the default highest priority interrupt.

READ: Anytime

WRITE: Only if I mask in CCR = 1

Interrupt test registers

These registers are used in special modes for testing the interrupt logic and priority without needing to know which modules and what functions are used to generate the interrupts. Each bit is used to force a specific interrupt vector by writing it to 1. Bits are named with INTE through INT0 to indicate vectors \$FFxE through \$FFx0. These bits can be written only in special modes and only with WRTINT (ITCR bit 4) = 1. In addition, I-interrupts must be masked using the I bit in the CCR. In this state, the interrupt input lines to the interrupt module will be disconnected and interrupts will be caused only through these registers. These bits can also be read in special modes to view that an interrupt caused by a module has reached the INT module.

There is a test register for every 8 interrupts implemented in a particular MCU. All of the test registers share the same address, and are individually selected using the value stored in the ADR3 – ADR0 bits of the Interrupt Control Register (ITCR).

NOTE: *When ADR3–ADR0 have the value of \$F, only bits 2–0 in the ITEST register will be accessible. That is, vectors higher than \$FFF4 cannot be tested using the test registers and bits 7–3 will always read 0. If ADR3–ADR0 point to an unimplemented test register, writes will have no effect and reads will always return 0.*

ITCR — Interrupt Test Control Register

Address Offset: \$0015

	Bit 7	6	5	4	3	2	1	Bit 0
	0	0	0	WRTINT	ADR3	ADR2	ADR1	ADR0
Reset:	0	0	0	0	1	1	1	1

WRTINT — Write to the Interrupt Test Registers

Read anytime; Write only in special modes and with I-mask and X-mask set.

1 = Disconnect the interrupt inputs from the priority decoder and use the values written into the ITEST registers instead.

0 = Disables writes to the test registers; reads of the test registers will return the state of the interrupt

NOTE: *Any interrupts which are pending at the time that WRTINT is set will remain until they are overwritten.*

ADR3 – ADR0 — Test register select bits

Write anytime, read anytime

These bits determine which test register is selected on a read or write. The hexadecimal value written here will be the same as the upper nibble of the lower byte of the vectors selects. That is, an “F” written into ADR3 – ADR0 will select vectors \$FFFE – \$FFF0 while a “7” written to ADR3 – ADR0 will select vectors \$FF7E – \$FF70.

Resets and Interrupts

ITEST — Interrupt Test Register

Address Offset: \$0016

	Bit 7	6	5	4	3	2	1	Bit 0
	INTE	INTC	INTA	INT8	INT6	INT4	INT2	INT0
Reset:	0	0	0	0	0	0	0	0

Read: When ADR3–ADR0 have the value of \$F, only bits 2–0 in the ITEST register will be accessible. That is, vectors higher than \$FFF4 cannot be tested using the test registers and bits 7–3 will always read 0. If ADR3–ADR0 point to an unimplemented test register, writes will have no effect and reads will always return 0.

Write: Only in special modes and with WRTINT = 1 and CCR I mask = 1.

Resets

There are four possible sources of reset. Power-on reset (POR), and external reset on the $\overline{\text{RESET}}$ pin share the normal reset vector. The computer operating properly (COP) reset and the clock monitor reset each has a vector. Entry into reset is asynchronous and does not require a clock but the MCU cannot sequence out of reset without a system clock.

Power-On Reset

An on-chip Power-On Reset (POR) circuit detects when VDD to the MCU has reached a certain level and triggers the internal power on reset sequence.

Figure 11 and Figure 12 show the power-up sequence for cases when the $\overline{\text{RESET}}$ pin is tied to VDD and when the $\overline{\text{RESET}}$ pin is held low.

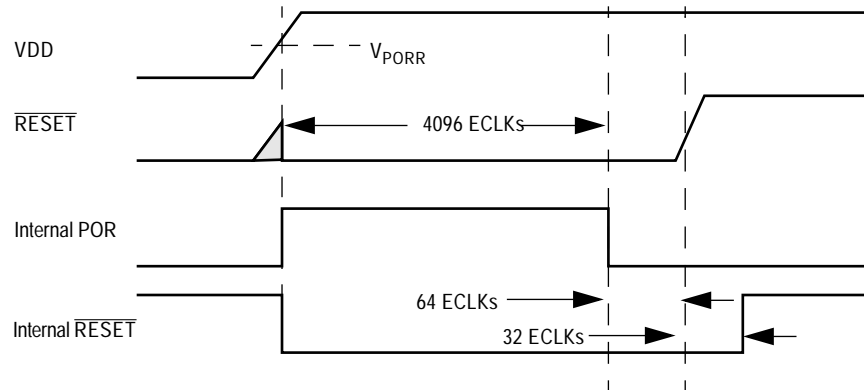

Figure 11 $\overline{\text{RESET}}$ pin tied to VDD (by a pull-up resistor)

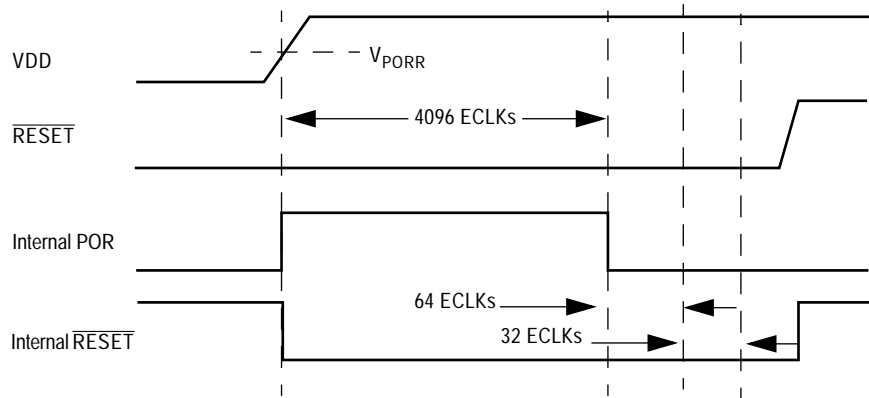

Figure 12 $\overline{\text{RESET}}$ pin held low externally

For the POR to be rearmed, VDD must fall to V_{PORA} or below before the circuit asserts a power-on reset (see Figure 13). The $\overline{\text{RESET}}$ pin will be asserted low until VDD has risen to a level above V_{PORR} . At this point the POR sequence will restart.

An external voltage level detector, or other external reset circuit, is the usual source of reset in a system. The POR circuit only initializes internal circuitry during cold starts and cannot be used to force a reset as system voltage drops. It is important to use an external low voltage reset circuit (such as an MC33464-48) to prevent power transitions or corruption of RAM or EEPROM.

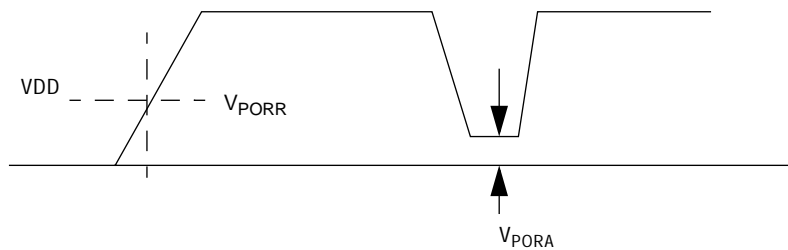

Figure 13 POR Re-arm

External Reset

External circuitry connected to the $\overline{\text{RESET}}$ pin should not include a large capacitance that would interfere with the ability of this signal to rise to a valid logic one within 32 ECLK cycles after the low drive is released. Upon detection of any reset, an internal circuit drives the $\overline{\text{RESET}}$ pin low and a clocked reset sequence controls when the MCU can begin normal processing.

NOTE: *Entry into reset is asynchronous and does not require a clock. However, the MCU cannot sequence out of reset without a system clock.*

In the case of POR or a clock monitor failure, a 4096 ECLK cycle oscillator startup delay is imposed before the reset recovery sequence starts ($\overline{\text{RESET}}$ is driven low throughout this 4096 cycle delay.) The internal reset recovery sequence then drives $\overline{\text{RESET}}$ low for 64 to 65 ECLK cycles and releases the drive to allow $\overline{\text{RESET}}$ to rise. 32 ECLK cycles later this circuit samples the $\overline{\text{RESET}}$ pin to see if it has risen to a logic one level. If $\overline{\text{RESET}}$ is low at this point, the reset is assumed to be coming from an external request and the internally latched states of the COP timeout and clock monitor failure are cleared so the normal reset vector (\$FFFE:FFFF) is taken when $\overline{\text{RESET}}$ is finally released. If $\overline{\text{RESET}}$ is high after this 32 cycle delay, the reset source is tentatively assumed to be either a COP failure or a clock monitor failure. If the internally latched state of the clock monitor fail circuit is true, processing begins by fetching the clock monitor vector (\$FFFC:FFFD). If no clock monitor failure is indicated, and the latched state of the COP timeout is true, processing begins by fetching the COP vector (\$FFFA:FFFB). If neither clock monitor fail nor COP timeout are pending, processing begins by fetching the normal reset vector (\$FFFE:FFFF).

COP Reset

The COP watchdog enables the user to check that a program is running and sequencing properly. When the COP is being used, software is responsible for keeping a free running watchdog timer from timing out. If the watchdog timer times out it is an indication that the software is no longer being executed in the intended sequence; thus a system reset is initiated. Three control bits in the COPCTL register allow selection of seven COP time-out periods.

When COP is enabled, the program must write \$55 and \$AA (in this order) to the ARMCOP register during the selected time-out period. Once this is done, the internal COP counter resets to the start of a new time-out period. If the program fails to do this the part will reset. Also, if any value other than \$55 or \$AA is written, the part is immediately reset.

Windowed COP operation is enabled by setting WCOP in the COPCTL register. In this mode, writes to the ARMCOP register must occur in the last 25% of the selected time-out period. A premature write will immediately reset the part.

To reset the internal COP counter to the start of a COP time-out period, set both the RTI rate select bits RTICTL[6:0] and the COP rate select bits COPCTL[2:0] to zero.

Clock Monitor Reset

If clock frequency falls below a predetermined limit when the clock monitor is enabled, a reset occurs.

The clock monitor circuit is based on an internal resistor-capacitor (RC) time delay. If no external clock edges are detected within this RC time delay, the clock monitor generates a system reset. The clock monitor function is enabled/disabled by the CME control bit in the PLLCTL register. This time-out is based on an RC delay so that the clock monitor can operate without any MCU clocks.

The input to the clock monitor is the reference clock (REFCLK.)

Effects of Reset

When a reset occurs, MCU registers and control bits are changed to known start-up states, as follows.

Operating Mode and Memory Map

Operating mode and default memory mapping are determined by the states of the BKGD, MODA, and MODB pins during reset. The MODA, MODB, and MODC bits in the MODE register reflect the status of the mode-select inputs at the rising edge of reset. Operating mode and default maps can subsequently be changed according to strictly defined rules.

Clock and Watchdog Control Logic

The COP watchdog system is enabled, with the CR[2:0] bits set for the longest duration time-out. The clock monitor is disabled. The RTIF flag is cleared and automatic hardware interrupts are masked. The rate control bits are cleared, and must be initialized before the RTI system is used.

Interrupts

PSEL is initialized in the HPRIO register with the value \$F2, causing the external $\overline{\text{IRQ}}$ pin to have the highest I-bit interrupt priority. The $\overline{\text{IRQ}}$ pin is configured for level-sensitive operation (for wired-OR systems). However, the interrupt mask bits in the CPU12 CCR are set to mask X- and I-related interrupt requests.

Parallel I/O

If the MCU comes out of reset in a single-chip mode, all ports are configured as general-purpose high-impedance inputs.

If the MCU comes out of reset in an expanded mode, port A and port B are used for the address/data bus, and port E pins are normally used to control the external bus (operation of port E pins can be affected by the PEAR register). Out of reset, port K, port E, port H, port J, port M, port T, port S, port P, port ATD0 and port ATD1 are all configured as general-purpose inputs.

Resets and Interrupts

Central Processing Unit	After reset, the CPU fetches a vector from the appropriate address, then begins executing instructions. The stack pointer and other CPU registers are indeterminate immediately after reset. The CCR X and I interrupt mask bits are set to mask any interrupt requests. The S bit is also set to inhibit the STOP instruction.
Memory	After reset, the internal register block is located from \$0000 to \$03FF, RAM is at \$1000 to \$3FFF, and EEPROM is located at \$0000 to \$0FFF. In single chip mode one 16K byte FLASH EEPROM module is located from \$4000 to \$7FFF and \$C000 to \$FFFF, and the other sixteen 16K byte FLASH EEPROM modules are accessible through the program page window located from \$8000 to \$BFFF.
Other Resources	The enhanced capture timer (ECT), pulse width modulation timer (PWM), serial communications interfaces (SCI0 and SCI1), serial peripheral interfaces (SPI0, SPI1 and SPI2), inter-IC bus (IIC), Byte Level Data Link Controller (BDLC), Motorola Scalable CANs (MSCAN0,.. MSCAN4), and analog-to-digital converters (ATD0 and ATD1) are off after reset.

Register Stacking

Once enabled, an interrupt request can be recognized at any time after the I bit in the CCR is cleared. When an interrupt service request is recognized, the CPU responds at the completion of the instruction being executed. Interrupt latency varies according to the number of cycles required to complete the instruction. Some of the longer instructions can be interrupted and will resume normally after servicing the interrupt.

When the CPU begins to service an interrupt, the instruction queue is cleared, the return address is calculated, and then it and the contents of the CPU registers are stacked as shown in [Table 25](#).

Table 25 Stacking Order on Entry to Interrupts

Memory Location	CPU Registers
SP – 2	RTN _H : RTN _L
SP – 4	Y _H : Y _L
SP – 6	X _H : X _L
SP – 8	B : A
SP – 9	CCR

After the CCR is stacked, the I bit (and the X bit, if an \overline{XIRQ} interrupt service request is pending) is set to prevent other interrupts from disrupting the interrupt service routine. The interrupt vector for the highest priority source that was pending at the beginning of the interrupt sequence is fetched, and execution continues at the referenced location. At the end of the interrupt service routine, an RTI instruction restores the content of all registers from information on the stack, and normal program execution resumes.

If another interrupt is pending at the end of an interrupt service routine, the register unstacking and restacking is bypassed and the vector of the interrupt is fetched.



Voltage Regulator (VREG)

Contents

Overview	159
Features	159
Block Diagram	160
Functional Description	161
External Pin Connection	161
Reset Initialization	164
Modes of Operation	164

Overview

The voltage regulator (VREG) converts the external VDDR (5V±5%) supply to VDD and VDDPLL (2.5V ± 10%) used to supply the internal core logic as well as PLL and clock system.

Features

- Dual linear voltage regulator with nmos output transistors
- Standby mode to minimize power consumption
- Voltage reference derived from VDDA/VSSA
- Power on reset generator

Voltage Regulator (VREG)

Block Diagram

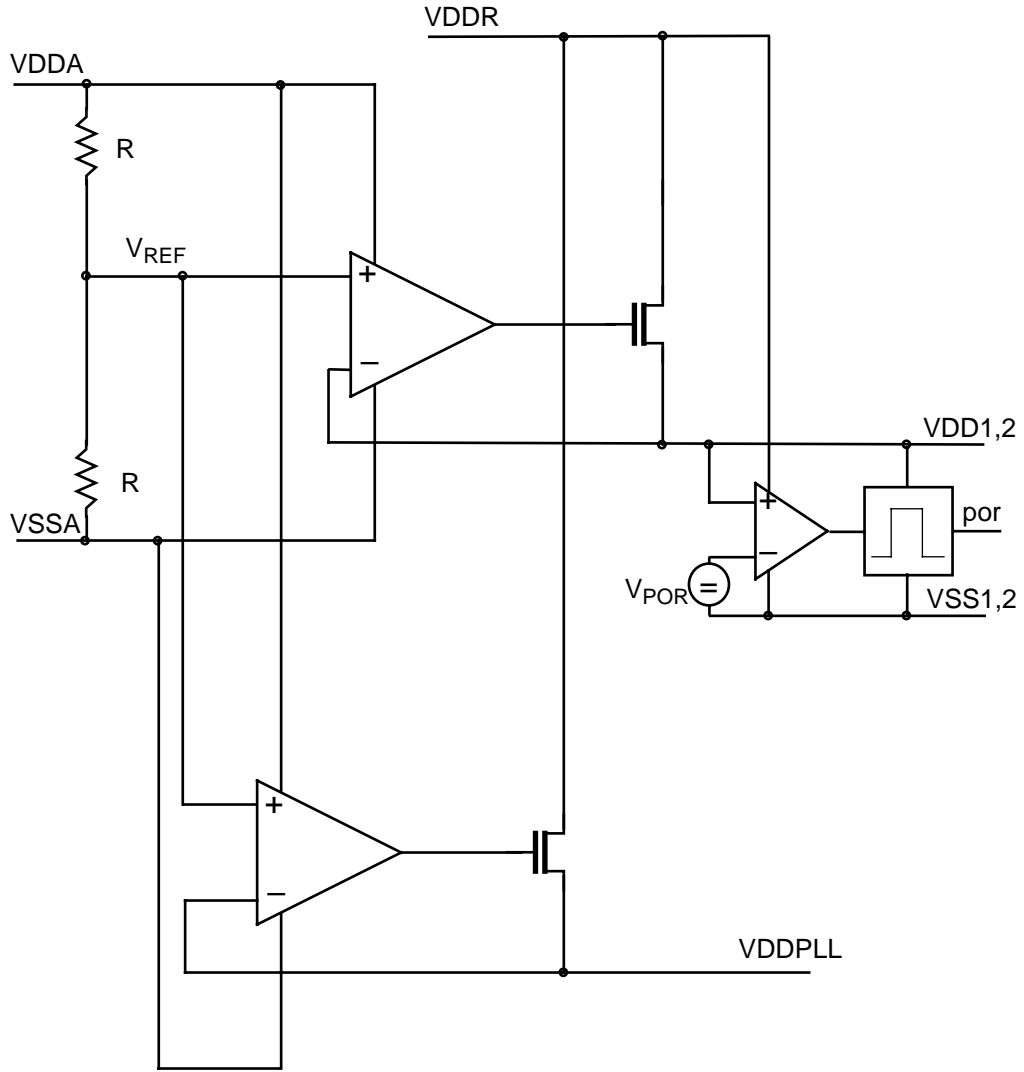

Figure 14 VREG Block Diagram

Functional Description

The voltage regulator module generates the supply voltage needed for the core logic as well as for the oscillator/pll section. The reference for the regulation loops are derived from a voltage divider connected between VDDA and VSSA. Both regulation loops, VDD and VDDPLL, consist of an operational amplifier driving an nmos power transistor in unit gain configuration. If there is no significant demand of output current (the CPU is in stop or pseudo stop mode) the voltage regulator is brought into standby mode, to decrease power consumption of the voltage regulator itself.

The voltage regulator can be enabled/disabled by the logic level on the VREGEN pin.

The level of VDD is internally monitored to generate a power on reset signal. If VDD is below $V_{POR\text{A}}$ reset will be asserted and a power on reset sequence will be triggered as soon as VDD rises above $V_{POR\text{R}}$.

Change of VDDA or VSSA levels will directly influence the voltage levels at VDD and VDDPLL. Because of this reason, it is sufficient to monitor the level of VDDA externally to generate a system reset if the supply voltage is out of specification limits.

Please note VDDA, VDDR and VSSX are internally connected by anti parallel diodes.

External Pin Connection

The PCB must be carefully laid out to ensure proper operation of the voltage regulator as well as of the MCU itself. The following rules must be observed:

- Every supply pair must be decoupled by a ceramic capacitor connected as near as possible to the corresponding pins (C1 – C6).
- Central point of the ground star should be the VSSR pin.

Voltage Regulator (VREG)

- Use low ohmic low inductance connections between VSS1, VSS2 and VSSR.
- VSSPLL must be directly connected to VSSR.
- Keep traces of VSSPLL, EXTAL and XTAL as short as possible and occupied board area for C7, C8 and Q1 as small as possible.
- Central power input should be fed in at the VDDA/VSSA pins.

Table 26 Recommended Components

Component	Purpose	Type	Value
C1	VDD1 filter cap	ceramic X7R	100 to 220nF
C2	VDD2 filter cap	ceramic X7R	100 to 220nF
C3	VDDA filter cap	ceramic X7R	100nF
C4	VDDR filter cap	X7R/tantalum	>=100nF
C5	VDDPLL filter cap	ceramic X7R	100nF
C6	VDDX filter cap	X7R/tantalum	>=100nF
C7	OSC load cap	See PLL specification chapter	
C8	OSC load cap		
C9	PLL loop filter cap		
C10	PLL loop filter cap		
R1	PLL loop filter res		
Q1	Quartz		

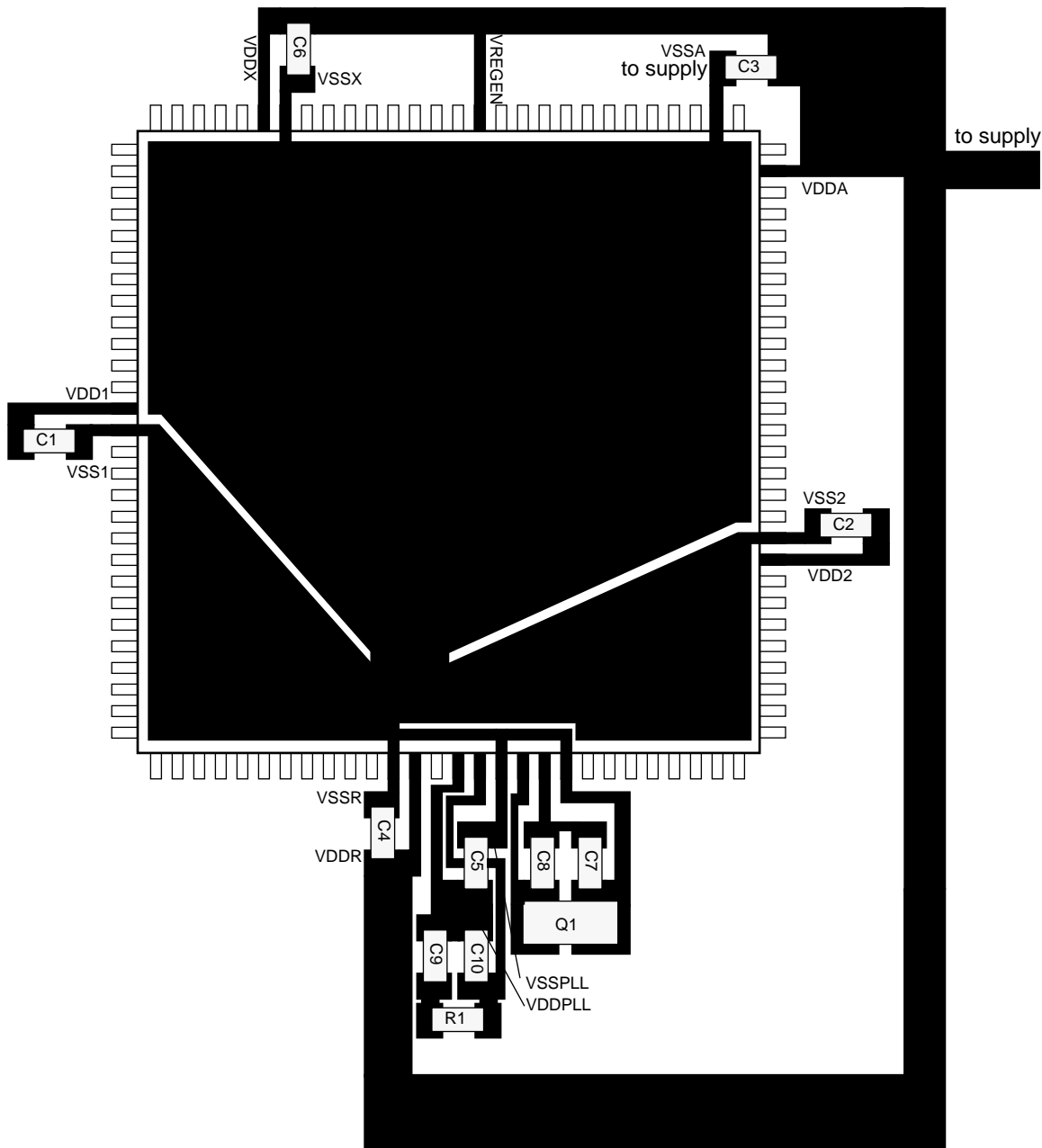

Figure 15 Recommended PCB layout

Voltage Regulator (VREG)

Reset Initialization

On system power up, the voltage regulator is started in run mode if VREGEN is connected to VDDA. VDDA must be monitored by an external voltage comparator to ensure that the MCU is not executing code while the power supply is out of specification limits to avoid erroneous operation.

Modes of Operation

The voltage regulator has three operating modes: run, standby and disabled.

Normal Operation: In run mode, both regulating loops of the voltage regulator are active.
Run This mode is selected whenever the CPU is neither in stop nor in pseudo stop mode and VREGEN is externally connected to VDDA.

Special Operation: Standby mode is selected when the CPU is in stop or pseudo stop mode
Standby and VREGEN is externally connected to VDDA. In standby mode, the gates of the power transistors are directly connected to the reference voltage $V_{REF} ((VDDA - VSSA)/2)$, the loop amplifiers are switched off. In this case, the voltage regulator acts as a voltage clamp. In standby mode, the source resistance of the regulator is increased, but power consumption is significantly decreased.

Special Operation: Shutdown mode can be selected by connecting VREGEN to VSSA. In
Disabled this case, VDD and VDDPLL ($2.5V \pm 10\%$) must be supplied externally. In shutdown mode, VREG will also generate the power on reset signal.

Flash EEPROM 256K

Contents

Glossary	165
Overview	166
Features	167
Block Diagram	168
Module Memory Map	169
Functional Description	174
Register Descriptions	177
External Pin Descriptions	190
Reset Initialization	190
Modes of Operation	190
Low Power Options	190
Interrupt Operation	191

Glossary

Flash Module	Includes Bus Interface, Command Control, NVM BIST controller and four Flash blocks of 64K bytes each.
Flash Block	64K byte Flash macro organized as 32K by 16bit Words. Includes high voltage generation and parametric test features.
Flash Page	16K bytes of Flash located in address range \$4000–\$7FFF, \$8000–\$BFFF or \$C000–\$FFFF.
Erase Sector	512 bytes of Flash (8 rows of 32 words)

Flash EEPROM 256K

Banked Register	A register operating on one flash block which shares the same register address as the equivalent registers for the other flash blocks. The active register bank is selected by two bank-select bits in the unbanked register space.
Unbanked Register	A register which operates on all flash blocks.
Command Sequence	Three-step MCU instructions sequence to program or erase the Flash.

Overview

The 256K flash module is comprised of four 64K bytes blocks. They serve as electrically erasable and programmable, non-volatile program and data memory. The flash EEPROM is ideal for program and data storage for single-chip applications allowing for field reprogramming without requiring external programming voltage sources.

Each 64K byte flash block is arranged in a 32K by 16-bit configuration and may be read as either bytes, aligned words or misaligned words. Access time is one bus cycle for byte, and aligned word and two bus cycles for misaligned word read. Write operations for program or erase are only allowed as aligned word accesses. Each 64K block is organized in 1024 rows of 32 words. An erase sector contains 8 rows or 512 bytes. The erase mode supports erase sector as small as 512 bytes as well as mass erase of each 64K byte block. An erased word reads \$FFFF and a programmed word reads \$0000.

The programming voltage required to program and erase the flash is generated internally by on-chip charge pumps. Program and erase operations are performed by a command driven interface from the microcontroller using an internal state machine. All flash blocks can be programmed or erased at the same time, however it is not possible to read from a flash block while it is being erased or programmed.

It is possible to perform 'Read-While-Write', i.e. program or erase one flash block under control of software routines executing out of another flash block.

Each block has hardware interlocks which protect data from accidental corruption. One protected area is located at the upper address of the flash module (\$xxxx –\$FFFF) normally used for boot code and another area is located at the lowest address (\$4000–\$xxxx). Two additional areas are located in the mapped memory pages \$3A (\$8000–\$xxxx) and \$3B (\$xxxx–\$BFFF).

Security information preventing intrusive access to the MCU is stored within the flash module.

Features

- 256K bytes of Flash made of four 64K byte blocks
 - Single supply program and erase.
 - Automated program and erase algorithm.
 - Interrupt on command completion.
 - All four flash blocks can be programmed and erased in parallel.
 - Read-While-Write.
 - Fast sector erase and word program operation.
 - Flexible protection scheme against accidental program or erase.
 - Security feature.

Flash EEPROM 256K

Block Diagram

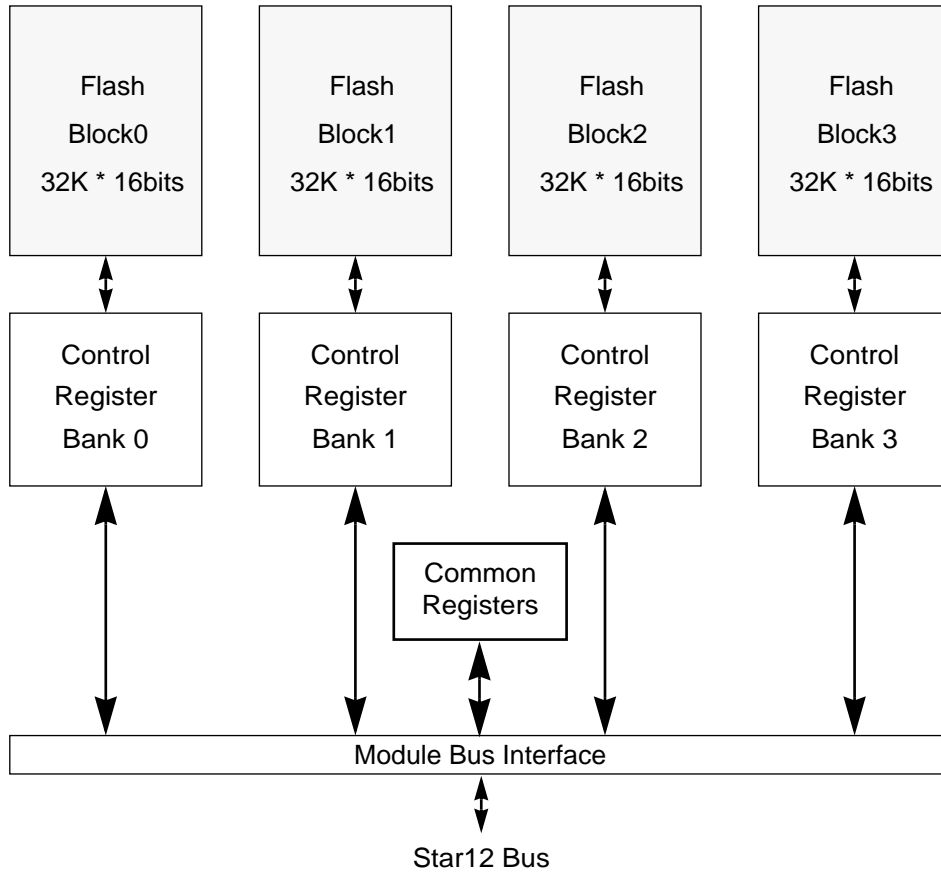

Figure 16 Flash 256K Block Diagram

Module Memory Map

Overview

The memory data is accessible in the address range \$4000–\$FFFF. All 16 pages of 16K bytes are accessible in the address range \$8000–\$BFFF by using the PPAGE register.

The flash module contains a bank of control and status registers in the same address space $INITRG + \$100 - INITRG + \$10F$ for each of the blocks. The active register bank selected via the Flash Configuration Register which is unbanked (unique) in the address space

Data Memory Map

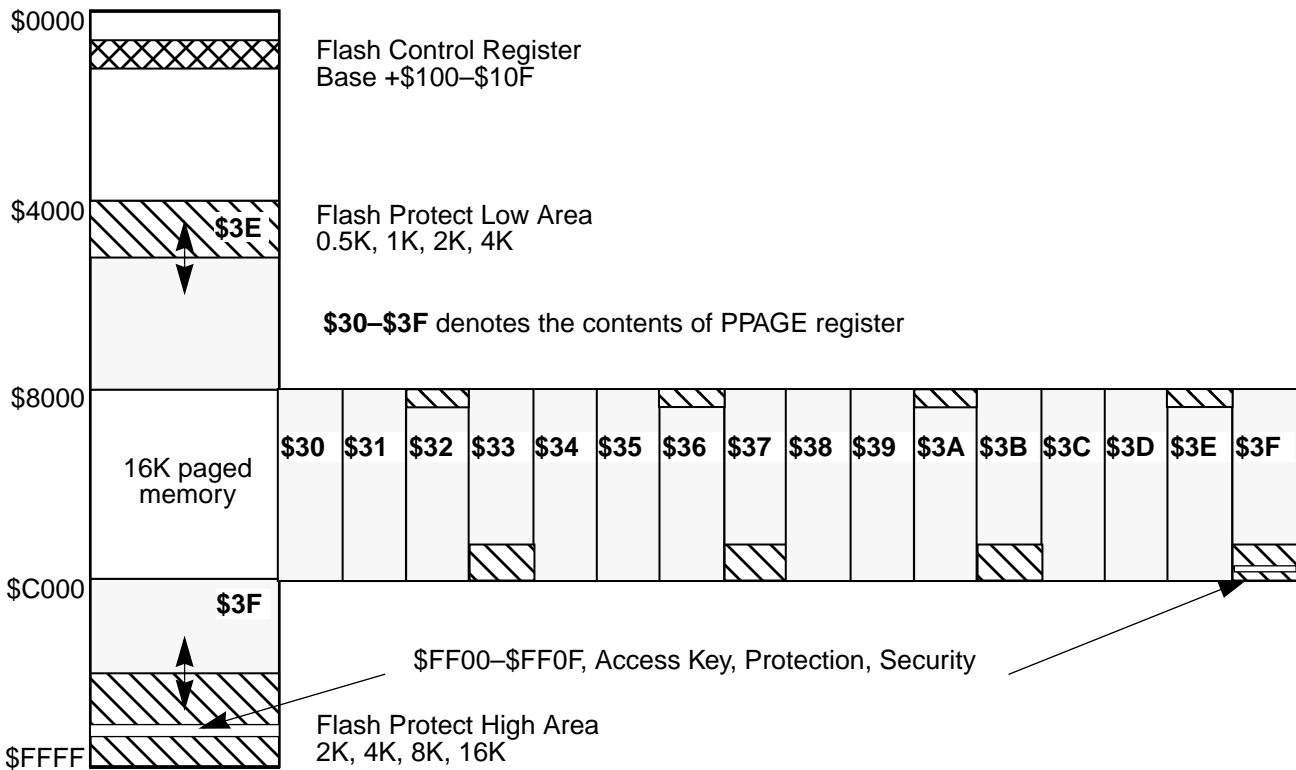

Figure 17 Flash Data Memory Map

Flash EEPROM 256K

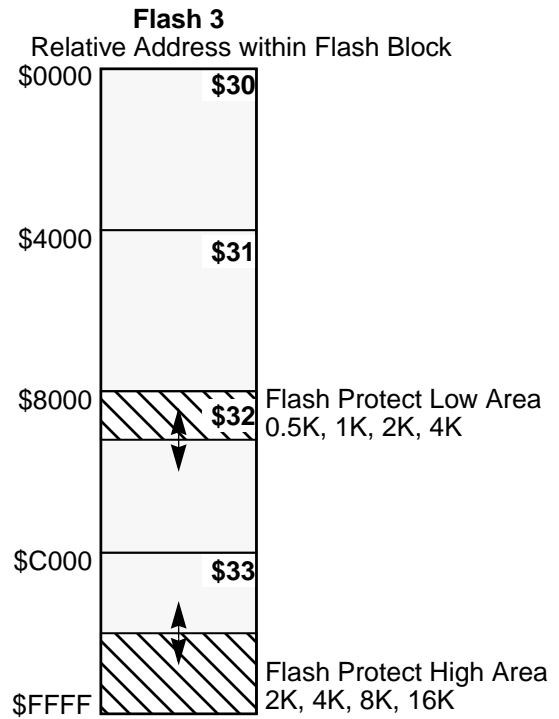
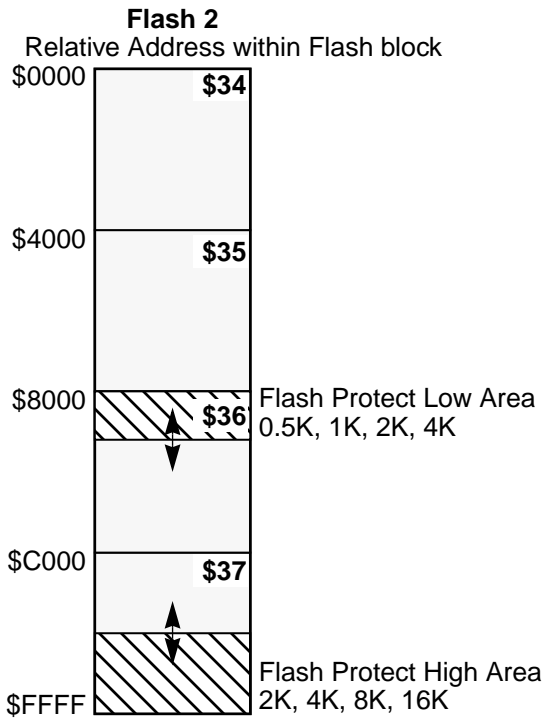
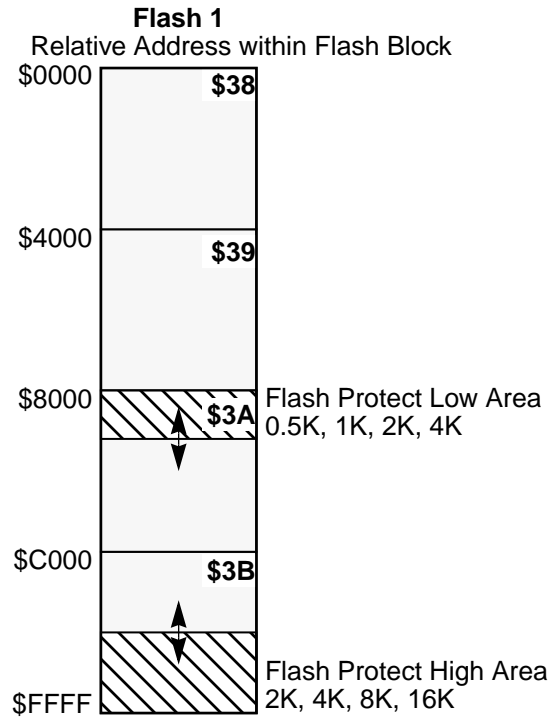
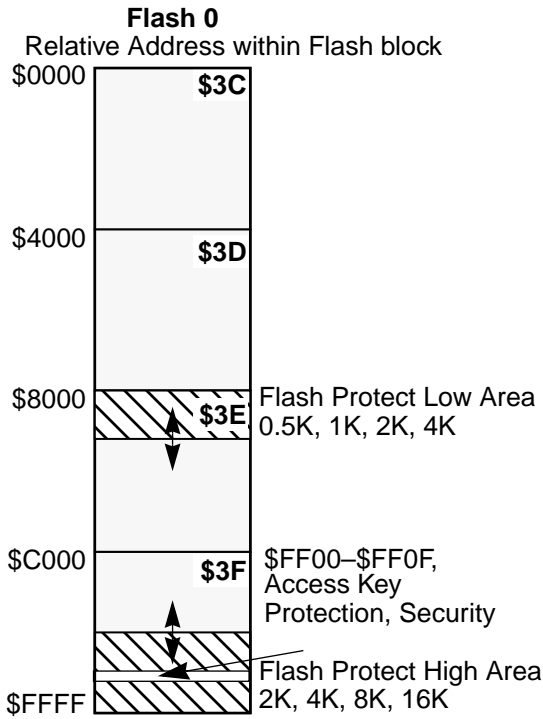

Figure 18 Flash Block Memory Maps and Paging



Flash Data Memory Map

Since the address range of the flash module is larger than the 64K (16-bit) native address space of the STAR12 the modules will be mapped through an address window from \$8000-\$BFFF in 16K byte blocks. The additional address bits are located in the PPAGE register.

Table 27 Flash Memory Mapping

MCU Address Range	PPAGE	Flash Block	Block Relative Address
\$4000-\$7FFF	unpaged \$3E	0	\$8000-\$BFFF
\$8000-\$BFFF	\$30	3	\$0000-\$3FFF
“	\$31	3	\$4000-\$7FFF
“	\$32	3	\$8000-\$BFFF
“	\$33	3	\$C000-\$FFFF
“	\$34	2	\$0000-\$3FFF
“	\$35	2	\$4000-\$7FFF
“	\$36	2	\$8000-\$BFFF
“	\$37	2	\$C000-\$FFFF
“	\$38	1	\$0000-\$3FFF
“	\$39	1	\$4000-\$7FFF
“	\$3A	1	\$8000-\$BFFF
“	\$3B	1	\$C000-\$FFFF
“	\$3C	0	\$0000-\$3FFF
“	\$3D	0	\$4000-\$7FFF
“	\$3E	0	\$8000-\$BFFF
“	\$3F	0	\$C000-\$FFFF
\$C000-\$FFFF	unpaged \$3F	0	\$C000-\$FFFF

Flash EEPROM 256K
**Flash Protection
Option Fields**

Flash block 0 also holds a field of 16-bytes containing Security, Protection as well as “backdoor” comparison bytes. The layout of this field is as follows:

Table 28 Flash 0 Protection/Security Field

Address	Size	Description
\$FF00–\$FF07	8	Backdoor comparison key
\$FF08–\$FF09	2	Reserved
\$FF0A	1	Protection byte for Flash block 3
\$FF0B	1	Protection byte for Flash block 2
\$FF0C	1	Protection byte for Flash block 1
\$FF0D	1	Protection byte for Flash block 0
\$FF0E	1	Reserved
\$FF0F	1	Security Byte

**Register Memory
Map**

In order to accommodate several flash blocks with a minimum of register address space, a set of registers (\$_104–\$_10B) are duplicated in four banks. The active bank is selected by the bits BKSEL[1:0] in the unbanked Flash Configuration Register (FCNFG).

Register name		Bit 7	6	5	4	3	2	1	Bit 0	Addr. Offset
FCLKDIV	Read:	FDIVLD	PRDIV8	FDIV5	FDIV4	FDIV3	FDIV2	FDIV1	FDIV0	\$0000
	Write:									
FSEC	Read:	KEYEN	NV6	NV5	NV4	NV3	NV2	SEC01	SEC00	\$0001
	Write:									
Reserved for Factory Test	Read:	0	0	0	0	0	0	0	0	\$0002
	Write:									
FCNFG	Read:	CBEIE	CCIE	KEYACC	0	0	0	BKSEL1	BKSEL0	\$0003
	Write:									

Unbanked Registers
Banked Registers

= Unimplemented or reserved

Figure 19 Flash Control Register Map

Register name		Bit 7	6	5	4	3	2	1	Bit 0	Addr. Offset
FPROT	Read:	FPOPEN	F	FPHDIS	FPHS1	FPHS0	FPLDIS	FPLS1	FPLS0	\$0004
	Write:									
FSTAT	Read:	CBEIF	CCIF	PVIOL	ACCERR	0	BLANK	0	0	\$0005
	Write:									
FCMD	Read:	0	ERASE	PROG	0	0	ERVER	0	MASS	\$0006
	Write:									
Reserved for Factory Test	Read:	0	0	0	0	0	0	0	0	\$0007
	Write:									
Reserved for Factory Test	Read:	0	0	0	0	0	0	0	0	\$0008
	Write:									
Reserved for Factory Test	Read:	0	0	0	0	0	0	0	0	\$0009
	Write:									
Reserved for Factory Test	Read:	0	0	0	0	0	0	0	0	\$000A
	Write:									
Reserved for Factory Test	Read:	0	0	0	0	0	0	0	0	\$000B
	Write:									
Unused	Read:	0	0	0	0	0	0	0	0	\$000C
	Write:									
Unused	Read:	0	0	0	0	0	0	0	0	\$000D
	Write:									
Unused	Read:	0	0	0	0	0	0	0	0	\$000E
	Write:									
Unused	Read:	0	0	0	0	0	0	0	0	\$000F
	Write:									

= Unimplemented or reserved

Figure 19 Flash Control Register Map (Continued)

NOTE: Register Address = Base Address + Address Offset, where the Base Address is defined at the MCU level and the Address Offset is defined at the module level.

Functional Description

NOTE: All internal program and erase timings are handled by a state machine. The timebase is derived from the oscillator clock OSCCLK via a programmable down counter. The command register as well as the associated address and data registers operate as a buffer and a register (2-stage FIFO), so that a new command along with the necessary data and address can be stored to the buffers while the previous command is still in progress. Buffers empty condition as well as command completion are signalled by flags in the status register. Interrupts will be generated if enabled. The main reason for this approach is that the maximum high-voltage active time for a flash row is limited to t_{HV} . Starting and stopping the high voltage after every word however would increase the programming time by a factor of two. The internal programming state machine will therefore keep the high voltage circuitry alive if a new program command operating on the same flash row (only address bits A[5:1] are allowed to change) is available, when the current program command is completed. The next programming cycle can then start without a delay. However if the command has changed, the address is not within the same row or the command buffer is empty, the high voltage will be turned off and restarted with the new command if required.

Program and Erase Procedures

Prior to issuing any program or erase commands it is necessary to program the FCLKDIV register to divide the oscillator clock to within the 150KHz to 200KHz range. Program and erase commands will not function if this register has not been initialized. See FCLKDIV register description for further details.

A Command State Machine, shared between all four flash blocks, is used to supervise the command sequence.

To prepare for a program or erase command sequence it is necessary to set the PPAGE and FCNFG registers as follows:

1. Write to bits BKSEL[1:0] in the FCNFG register to select the bank of registers associated with the 64K flash block to be programmed or erased (i.e. Flash 0, 1, 2 or 3) See [Figure 17](#) for further details.

2. Write to the (core) PPAGE register (\$x030) to select one of the 16K page to be programmed if programming in the \$8000–\$BFFF address range. There is no need to set PPAGE when programming in the \$4000–\$7FFF or \$C000–\$FFFF address ranges.

After this initialization step the CBEIF flag should be tested to ensure that the address, data and command buffers are empty. If so, the command sequence can be started. The 3-step command sequence must be strictly adhered to and no intermediate writes to Flash registers are permitted between the 3 steps. The command sequence is as follows:

1. Write an aligned data word (16-bits) to be programmed to the flash address space between \$4000 and \$FFFF. The address and data will be stored in internal buffers. For program, all address bits are valid. For erase, the value of the data bytes is don't care. For mass erase the address can be anywhere in the available address space of the 64K byte block to be erased. For sector erase the address bits 8:0 are don't cared.
2. Write the program or erase command to the command buffer.
3. Reset CBEIF flag by writing a "1". This will launch the command. The ACCERR and PVIOL flags should be tested to ensure the command sequence was valid. Five cycles after the CBEIF flag is cleared the CCIF flag will be cleared by hardware indicating that the command was successfully launched. The CBEIF flag will be set again indicating the address, data and command buffers are ready for a new command sequence to begin.

The completion of the command is indicated by the CCIF flag setting (Command Complete Interrupt Flag)

The Command State Machine will flag errors in program or erase sequences by means of the ACCERR (access error) and PVIOL (protection violation) flags in the FSTAT register. An erroneous command sequence will immediately abort and set the appropriate flag. The user has then to clear the ACCERR or PVIOL flags before being able to commence another command sequence.

The ACCERR flag will be set during the command sequence if any of the following illegal operations are performed. Such operations will cause the command sequence to immediately abort:

1. Writing to the flash address space before initializing FCLKDIV.
2. Writing to the flash address space in the range \$8000–\$BFFF when PPAGE does not select a 16K block in the flash selected by BKSEL[1:0].
3. Writing to the flash address space \$4000–\$7FFF or \$C000–\$FFFF with BKSEL[1:0] not selecting Flash 0.
4. Writing a misaligned word or a byte to the flash address space.
5. Writing to the flash address space while CBEIF is not set.
6. Writing a second aligned word to the flash address space before executing a program or erase command on the previously written word.
7. Writing to any Flash register other than FCMD after writing an aligned word to the flash address space.
8. Writing a second command to the FCMD register before executing the previously written command.
9. Writing a MASS erase command to FCMD while any protection is enabled. See FPROT register description.
10. Writing a SECTOR erase command to FCMD while protection is enabled for that sector. See FPROT register description.
11. Writing to any Flash register other than FSTAT (to clear CBEIF) after writing to the command register.
12. Reading from the flash block while a command sequence is being entered or a program or erase command is being executed (i.e. CCIF not set). Such a read access returns non valid data. Any other block which is not being programmed can be read.

By writing a 0 to the CBEIF flag the command sequence can be aborted after the aligned word write to the flash address space or after writing a command to the FCMD register and before the command is launched.

The PVIOL flag will be set after the aligned write to the flash address space if an attempt to program or erase a protected area of the flash array is made. Such an operation will cause the command sequence to immediately abort. The user must clear the PVIOL flag before being able to commence another command sequence.

Register Descriptions

NOTE: All bits of all registers in this module are completely synchronous to internal clocks during a register read.

FCLKDIV — Flash Clock Divider Register

Address Offset: \$0000

	Bit 7	6	5	4	3	2	1	Bit 0
Read:	FDIVLD	PRDIV8	FDIV5	FDIV4	FDIV3	FDIV2	FDIV1	FDIV0
Write:								
Reset:	0	0	0	0	0	0	0	0

 = Reserved or unimplemented

Read: Anytime

Write: Once in normal mode, anytime in special mode

This register is unbanked. It is used to divide the external oscillator frequency down to a frequency required by the program/erase state machines.

FDIVLD — Flash Clock Divider Loaded

This bit is set when the FCLKDIV register is written to. If this bit is “0” the register has not been written since the last reset. Trying to program or erase the flash without having written to this register previously will result in an access error and the command will not be executed.

1 = Register has been written to since the last reset.

0 = Register has not been written to.

PRDIV8 — Enable Prescaler by 8

1 = Enables a prescaler by 8 before feeding into the FCLKDIV divider.

0 = OSCCLK is directly fed into the FCLKDIV divider

FDIV[5:0] — Flash Clock Divider

The combination of FDIV8 and FDIV[5:0] is used to divide the oscillator clock down to a frequency of 150KHz - 200KHz. This resulting clock, FCLK, is used to drive the program and erase state machines for the flash.

For frequencies of OSCCLK > 12.8MHz the Prescaler bit FDIV8 must be turned on.

FCLKDIV must be chosen such that the following equation is valid.

$$\text{If FDIV8} == 1 \text{ then CLK} = \text{OSCCLK} / 8, \text{ else CLK} = \text{OSCCLK}$$

$$\text{FCLKDIV} = \text{INT} (\text{CLK}[\text{KHz}] / 200\text{KHz})$$

The clock to the flash timing control is therefore:

$$\text{FCLK} = \text{CLK} / (\text{FDIV}[5:0] + 1)$$

$$150\text{KHz} < \text{FCLK} \leq 200\text{KHz}$$

For example, if OSCCLK = 950KHz, FCLKDIV should be set to 4 and FDIV8 set to 0. The resulting FCLK is 190KHz. As a result the flash timings are increased by:

$$(200 - 190) / 200 \times 100\% = 5\%$$

Remark: INT means rounding towards 0.

Example: INT(950KHz/200KHz) = 4.

WARNING: *Programming the flash with OSCCLK < 500KHz should be avoided. Setting FCLKDIV to a value such that FCLK < 150KHz can destroy the flash due to overstress. Setting FCLKDIV to a value such that FCLK > 200KHz can result in improperly programmed memory cells.*

NOTE: *Command execution time will increase proportionally with the period of FCLK.*

Table 29 Example FCLKDIV settings

Oscillator Frequency	PRDIV8	FDIV[5:0]	FCLK Frequency	FCLK Period
1.0MHz	0	000100	200KHz	5us
2.0MHz	0	001001	200KHz	5us
4.0MHz	0	010011	200KHz	5us
8.0MHz	0	100111	200KHz	5us
16.0MHz	1	001001	200KHz	5us

FSEC — Flash Security Register

Address Offset: \$0001

	Bit 7	6	5	4	3	2	1	Bit 0
Read:	KEYEN	NV6	NV5	NV4	NV3	NV2	SEC01	SEC00
Write:								
Reset:	F	F	F	F	F	F	F	F

= Reserved or unimplemented

Read: Anytime

Write: Never

This register is unbanked. It holds all bits associated with the device security. This register is loaded from flash address \$FF0F during the reset sequence, indicated by “F” in the reset row of the register description.

KEYEN — Enable backdoor key to security

1 = Backdoor to flash read via BDM or external bus interface is enabled

0 = Backdoor to flash read via BDM or external bus interface is disabled

When KEYEN is set, the user can then bypass the security by:

1. Setting the KEYACC bit in the configuration (FCNFG) register.
2. Writing the correct four 16bit words to the flash using the backdoor comparison keys addresses.
3. Clear the KEYACC bit.
4. If all four 16bit words match the flash content, the MCU is unsecured by forcing the bits SEC[1:0] to the unsecure state.
5. If any of the four 16bit words does not match the flash content the MCU remains secured and a security violation signal is sent to the CPU.

The user has full control on those 4 words = 64 bits. The contents of the flash is not changed by unsecuring the device. After the next reset sequence the device is secured again unless the flash security byte was changed by program or erase.

NV[6:2] — Non Volatile flag bits

These 5 bits are available to the user as non-volatile flags

SEC0[1:0] — memory security bits

Those two bits define the secure state of the device

Table 30 Security States

SEC0[1:0]	Description
00	secured
01	secured
10	unsecured
11	secured

For further details on the operation of a secured device see security specification in section Operating Modes.

WARNING: *If security is enabled then in order to perform product analysis either it must be disabled by the backdoor key or the array must be totally erased.*

FCNFG — Flash Configuration Register

Address Offset: \$0003

	Bit 7	6	5	4	3	2	1	Bit 0
Read:	CBEIE	CCIE	KEYACC	0	0	0	BKSEL1	BKSEL0
Write:								
Reset:	0	0	0	0	0	0	0	0

= Reserved or unimplemented

Read: Anytime

Write: Anytime

This register is unbanked. It enables the interrupts, gates the security backdoor writes and selects the register bank to be operated on.

CBEIE — Command Buffers Empty Interrupt Enable

This bit enables the interrupts in case of empty address, data and command buffers.

- 1 = An interrupt will be requested whenever the CBEIF flag is set
- 0 = Command Buffers Empty Interrupts disabled

CCIE — Command Complete Interrupt Enable

This bit enables the interrupts in case of all commands being completed.

- 1 = An interrupt will be requested whenever the CCIF flag is set
- 0 = Command Complete Interrupts disabled

KEYACC — Enable Security Key Writing

- 1 = Writes to flash module are interpreted as keys to open the backdoor.
- 0 = Flash writes are interpreted as the start of a program or erase sequence.

BKSEL[1:0]— Register bank select

These two bits are used to select which of the four register banks are addressed. The register bank associated with Flash 0 is the default out of reset. The bank selection is according to the following table:

Table 31 Register Bank Selects

BKSEL[1:0]	Description
00	Flash 0
01	Flash 1
10	Flash 2
11	Flash 3

FPROT — Flash Protection Register

Address Offset: \$0004

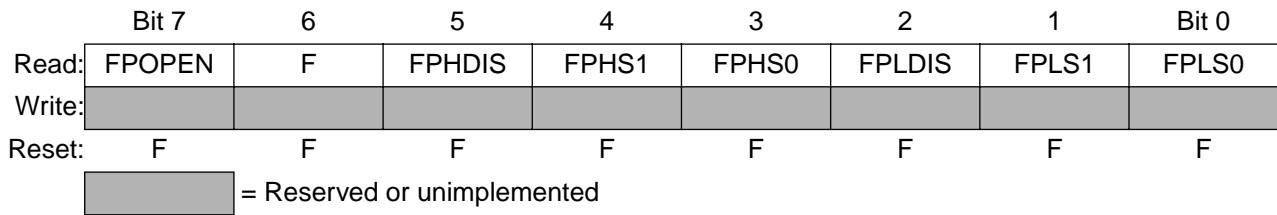

Read: Anytime
Write: Only in special modes

This register is banked.

The flash protection registers are loaded during the reset sequence from address \$FF0D for flash block 0, \$FF0C for flash block 1, \$FF0B for flash block 2 and \$FF0A for flash block 3. This is indicated by the “F” in the reset row of the register diagram. This register determines whether a whole block or subsections of a block are protected against accidental program or erase. Each flash block can have two protected areas, one starting from relative address \$8000 (called lower) towards higher addresses and the other growing downwards from \$FFFF (called higher). While the later is mainly targeted to hold the boot loader code since it covers the vector space (flash 0), the other area may be used to keep critical parameters. Trying to alter any of the protected areas will result in a protect violation error and bit PVIOL will be set in the Flash Status Register FSTAT. A mass erase of the full 64K byte block is only

possible when protection is fully disabled by setting the FPLDIS and FPHDIS bits.

In order to change the flash protection in special modes, the protection register can be written directly.

In order to change the protection in user mode the flash locations \$FF0A, \$FF0B, \$FF0C and \$FF0D have to be re-programmed and the MCU reset to reload the FPROT registers from those flash locations.

The size of the protected ranges for the lower and higher subsections are determined by FPHS1, FPHS0 and FPLS1, FPLS0 respectively. The protections are disabled by the bits FPHDIS and FPLDIS respectively.

FPOPEN — Opens the flash block or subsections of it for program or erase.

1 = The flash block or subsections are enabled to program or erase.

0 = The whole flash block is protected. In this case the other bits within the protect register are don't care.

FPHDIS — Flash Protection Higher address range disable

This bit determines whether there is a protected area at the higher end of the flash block address map.

1 = Protection disabled

0 = Protection enabled

FPHS[1:0] — Flash Protection Higher address size

These 2 bits determine the size of the protected area.

Table 32 Higher Address Range Protection

FPHS[1:0]	FLASH BLOCK	PPAGE	Protected Address Range	Protected Size
00	0	\$3F	\$F800-\$FFFF	2K
01	0	\$3F	\$F000-\$FFFF	4K
10	0	\$3F	\$E000-\$FFFF	8K
11	0	\$3F	\$C000-\$FFFF	16K
00	0	\$3F	\$B800-\$BFFF	2K
01	0	\$3F	\$B000-\$BFFF	4K
10	0	\$3F	\$A000-\$BFFF	8K
11	0	\$3F	\$8000-\$BFFF	16K
00	1	\$3B	\$B800-\$BFFF	2K
01	1	\$3B	\$B000-\$BFFF	4K
10	1	\$3B	\$A000-\$BFFF	8K
11	1	\$3B	\$8000-\$BFFF	16K
00	2	\$37	\$B800-\$BFFF	2K
01	2	\$37	\$B000-\$BFFF	4K
10	2	\$37	\$A000-\$BFFF	8K
11	2	\$37	\$8000-\$BFFF	16K
00	3	\$33	\$B800-\$BFFF	2K
01	3	\$33	\$B000-\$BFFF	4K
10	3	\$33	\$A000-\$BFFF	8K
11	3	\$33	\$8000-\$BFFF	16K

FPLDIS — Flash Protection Lower address range disable

This bit determines whether there is a protected area at the lower end of the flash block address map.

1 = Protection disabled

0 = Protection enabled

FPLS[1:0] — Flash Protection Lower Address size
 These 2 bits determine the size of the protected area.

Table 33 Lower Address Range Protection

FPLS[1:0]	FLASH BLOCK	PPAGE	Protected Address Range	Protected Size
00	0	\$3E	\$4000–\$41FF	512 Bytes
01	0	\$3E	\$4000–\$43FF	1K
10	0	\$3E	\$4000–\$47FF	2K
11	0	\$3E	\$4000–\$4FFF	4K
00	0	\$3E	\$8000–\$81FF	512 Bytes
01	0	\$3E	\$8000–\$83FF	1K
10	0	\$3E	\$8000–\$87FF	2K
11	0	\$3E	\$8000–\$8FFF	4K
00	1	\$3A	\$8000–\$81FF	512 Bytes
01	1	\$3A	\$8000–\$83FF	1K
10	1	\$3A	\$8000–\$87FF	2K
11	1	\$3A	\$8000–\$8FFF	4K
00	2	\$36	\$8000–\$81FF	512 Bytes
01	2	\$36	\$8000–\$83FF	1K
10	2	\$36	\$8000–\$87FF	2K
11	2	\$36	\$8000–\$8FFF	4K
00	3	\$32	\$8000–\$81FF	512 Bytes
01	3	\$32	\$8000–\$83FF	1K
10	3	\$32	\$8000–\$87FF	2K
11	3	\$32	\$8000–\$8FFF	4K

Flash EEPROM 256K
FSTAT — Flash Status Register

Address Offset: \$0005

	Bit 7	6	5	4	3	2	1	Bit 0
Read:	CBEIF	CCIF	PVIOL	ACCERR	0	BLANK	0	0
Write:								
Reset:	1	1	0	0	0	0	0	0

= Reserved or unimplemented

Read: Anytime

Write: Anytime to clear flags

This register is banked. The bits in this register are set by various conditions.

CBEIF — Command Buffers Empty Interrupt Flag

Indicates that the address, data and command buffers are empty so that a new command sequence can be started. The flag is cleared by writing a “1”. By clearing the flag the command sequence is launched. Writing a “0” aborts a command sequence that has not yet been launched and sets the ACCERR flag.

1 = Buffers are ready to accept a new command.

0 = Buffers are full.

CCIF — Command Complete Interrupt Flag

Indicates that there are no more commands pending. The flag is cleared by hardware. Writing has no effect.

1 = All commands are completed

0 = Command in progress

PVIOL — Protection violation

Indicates an attempt was made to program or erase an address in a protected memory area. A subsequent program or erase command cannot be executed while this flag is set. The flag is cleared by writing a “1”. Writing a “0” has no effect. The flag is also cleared by writing a new, valid command after CBEIF is cleared or when CCIF is clear.

1 = A protection violation has occurred.

0 = no failure

ACCERR — Access error

Indicates an illegal access to the flash block or violation of the defined command sequence. This can be:

1. Writing to the flash address space before initializing FCLKDIV.
2. Writing to the flash address space in the range \$8000–\$BFFF when PPAGE does not select a 16K block in the flash selected by BKSEL[1:0].
3. Writing to the flash address space \$4000–\$7FFF or \$C000–\$FFFF with BKSEL[1:0] not selecting Flash 0.
4. Writing a misaligned word or a byte to the flash address space.
5. Writing to the flash address space while CBEIF is not set.
6. Writing a second aligned word to the flash address space before executing a program or erase command on the previously written word.
7. Writing to any Flash register other than FCMD after writing an aligned word to the flash address space.
8. Writing a second command to the FCMD register before executing the previously written command.
9. Writing a MASS erase command to FCMD while any protection is enabled. See FPROT register description.
10. Writing a SECTOR erase command to FCMD while protection is enabled for that sector. See FPROT register description.
11. Writing to any Flash register other than FSTAT (to clear CBEIF) after writing to the command register.
12. Reading from the flash block while a command sequence is being entered or a program or erase command is being executed. (i.e. CCIF not set). Such a read access returns non valid data
13. The part enters STOP mode and a program or erase command is in progress. The command is aborted.

The flag is cleared by writing a “1”. Writing a “0” has no effect.

1 = Access error has occurred.

0 = Command sequence or command execution successfully completed.

Flash EEPROM 256K

BLANK — Blank Verify Flag

Indicates that the flash block is fully erased in response to an Erase-Verify command. The flag is cleared by writing a “1”. Writing a “0” has no effect.

- 1 = Flash block fully erased.
- 0 = Flash block not fully erased.

BITS[1:0] — These bits are reserved for factory testing and are not available to the user.

FCMD — Flash Command Buffer and Register

Address Offset: \$0006

	Bit 7	6	5	4	3	2	1	Bit 0
Read:	0	ERASE	PROG	0	0	ERVER	0	MASS
Write:								
Reset:	0	0	0	0	0	0	0	0

= Reserved or unimplemented

Read: Anytime

Write: After aligned write to the flash address space in the command sequence. (See PVIOL description in FSTAT register)

This register is banked and buffered.

ERASE — Erase flash

Erases a flash sector (512 bytes) or the whole flash depending on the MASS bit. Trying to erase a sector located in a protected area will result in a protection violation indicated by the PVIOL bit in the FSTAT register being set.

- 1 = Perform a sector erase if MASS=0 or a mass erase if MASS=1.
- 0 = -

PROG — Word programming

Trying to program a word located in a protected area will result in a protection error indicated by PVIOL set.

- 1 = Program memory
- 0 = -

ERVER — Enable Erase Verify

Verifies the flash block is fully erased. A successful verification will set the BLANK bit in the FSTAT register.

- 1 = Perform an erase verify after mass erase.
- 0 = -

MASS — Enables Mass Erase

Perform a mass erase of the selected 64K byte block. This bit works in conjunction with the ERASE bit. If any protection is active on the selected block, mass erase has no effect and the PVIOL bit in the FSTAT register is set.

Write at anytime.

- 1 = Perform a mass erase of the whole block.
- 0 = Perform sector erase.

Table 34 Valid Commands

Command	Meaning	Remarks
\$20	Memory Program	Program 1 word (2 bytes)
\$40	Sector Erase	Erase 512 bytes
\$41	Mass Erase	Erase all 64K bytes
\$05	Erase Verify	Verify all 64K bytes are erased
other	Illegal	Generate an access error

The registers \$107–\$10B are reserved for factory testing and are not available to the user.

External Pin Descriptions

This module does not have external pins relevant for the user.

Reset Initialization

Out of reset the module holds core activity while the Protection and Security registers are loaded from Flash 0. Thereafter, the Flash module is immediately accessible, operating in read mode.

If a reset occurs while any command is in progress that command will be immediately aborted. The state of the word being programmed or the sector / block being erased is not guaranteed.

Modes of Operation

Security Modes The flash module provides the necessary security information to the rest of the chip. This information is stored within a byte in the flash block 0 (\$FF0F). This byte is read automatically after each reset and stored in a volatile register. This information also protects the flash module from intrusive reads via the external bus interface or the BDM mode. The customer however can disable the security by providing a 64 bit key.

Low Power Options

When the array or the registers are not being accessed clocking to the register block is shut off to save power. The only exceptions to this are the flag bits in the FSTAT registers which are updated by internal state machines.

Run Mode No special current saving modes available.

Wait Mode When the MCU enters WAIT mode and any command is active (CCIF = 0) the command will be completed. If enabled, the CCIF interrupt can be used to waken the MCU out of Wait mode.

Stop Mode No low power options exist for this module in stop mode. If a command is active (CCIF = 0) when the MCU enters the STOP mode, the command will be aborted and the high voltage circuitry to the Flash array will be switched off.

Interrupt Operation

This module can generate an interrupt when all commands are completed or the address, data and command buffers are empty.

Interrupt Sources

Table 35 Flash 256K Interrupt Sources

Interrupt Source	Interrupt Flag	Local Enable	Global (CCR) Mask
Flash Address, Data and Command Buffers empty	CBEIF Flash 0,1,2 or 3	CBEIE	I Bit
All Commands are completed	CCIF Flash 0,1,2 or 3	CCIE	I Bit

NOTE: *Vector addresses and their relative interrupt priority are determined at the MCU level.*

The following algorithm is used for generating interrupt via the relevant block (see [Figure 20](#)).

This system uses the CBEIE and CBEIF as well as the block select bits (BLKSEL) to discriminate for the interrupt generation. By taking account of the selected block, the system is prevented from generating false interrupts when the command buffer is empty in an unselected block.

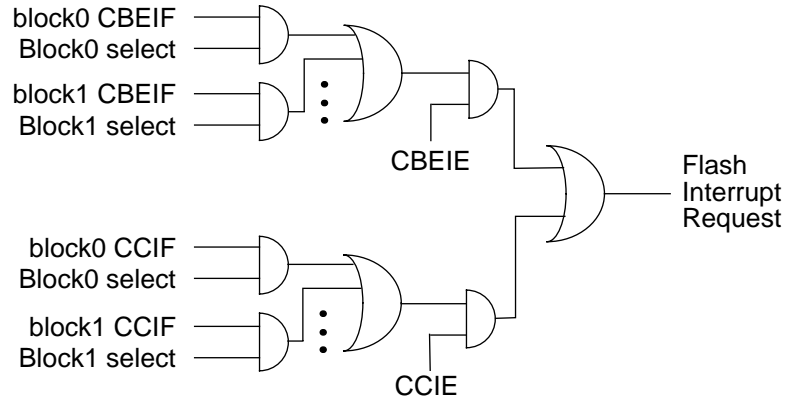

Figure 20 256K (4 Blocks) Flash Interrupt Implementation.

CAUTION: *When programming or erasing Flash Block 0 the interrupt vectors are not readable. It is therefor not recommended to program or erase the Flash Block 0 with interrupts enabled.*

Recovery from STOP or WAIT

The module can recover the part from WAIT, if the interrupts are enabled.

There is no capability to recover from STOP.

EEPROM 4K

Contents

Glossary	193
Overview	194
Features	194
Block Diagram	195
Module Memory Map	195
Functional Description	198
Register Descriptions	201
External Pin Descriptions	210
Reset Initialization	210
Modes of Operation	210
Interrupt Operation	211

Glossary

EEPROM Module	Includes Bus Interface, Command Control, NVM BIST controller and a 4k byte EEPROM block.
EEPROM Block	4K byte EEPROM macro organized as 2048 by 16bit Words including high voltage generation and parametric test features.
Erase Sector	4 bytes (2 words)
Command Sequence	Three-step MCU instructions sequence to program or erase the Flash.

Overview

The 4k byte EEPROM module serves as electrically erasable and programmable, non-volatile data memory without requiring external programming voltage sources.

The EEPROM may be read as either bytes, aligned words or misaligned words. Access time is one bus cycle for byte and aligned word and two bus cycles for misaligned word read. Write operations for program or erase are only allowed as aligned word accesses. The 4k byte array is organized in 2048 rows of 2 bytes. An erase sector contains 2 rows. The erase mode supports erase sector of 4 bytes as well as a mass erase of the entire 4k byte block.

The programming voltage required to program and erase the EEPROM is generated internally by on-chip charge pumps. Program and erase operations are performed by a command driven interface from the microcontroller using an internal state machine. It is not possible to read from the EEPROM block while it is being erased or programmed.

The EEPROM has hardware interlocks which protect data from accidental corruption. The protected area is located at the upper address end of the EEPROM module (\$xxxx – \$xFFF). The size of the protected area can be set from 0 to 512 bytes in multiples of 64 bytes and grows downwards from address \$xFFF.

Features

- 4k bytes of EEPROM
 - Single supply program and erase.
 - Automated program and erase algorithm.
 - Interrupt on command completion.
 - Fast sector erase and word program operation.
 - Flexible protection scheme against accidental program or erase.

Block Diagram

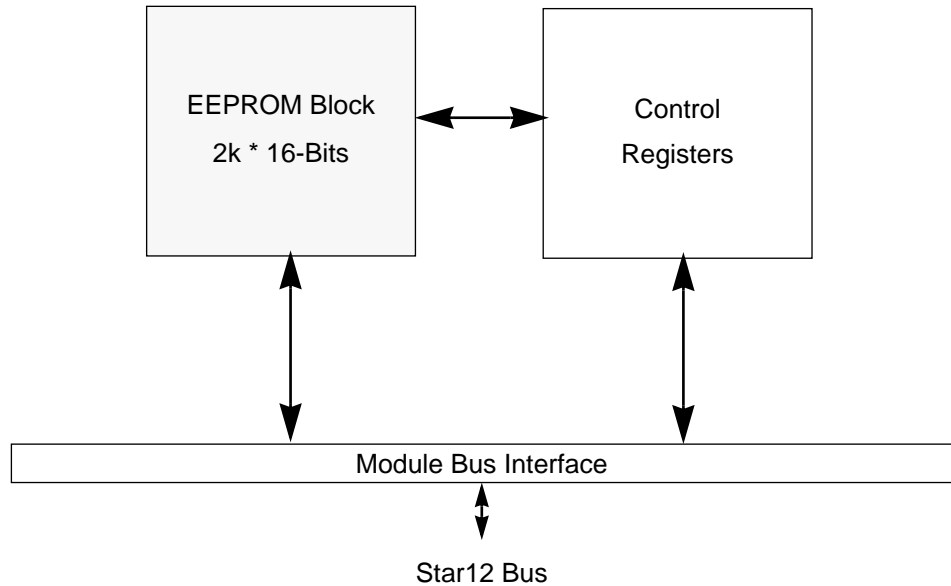

Figure 21 EEPROM 4K Block Diagram

Module Memory Map

Overview

The memory data is accessible in the address range \$x000 - \$xFFF and can be re-mapped to any 4k boundary in the MCU address range. After reset the MCU register block will be mapped on top of the EEPROM in the address range \$0000 - \$03FF. The EEPROM module contains a bank of control and status registers in the same address space INITRG +\$110 - INITRG +\$10B.

EEPROM 4K

Data Memory Map

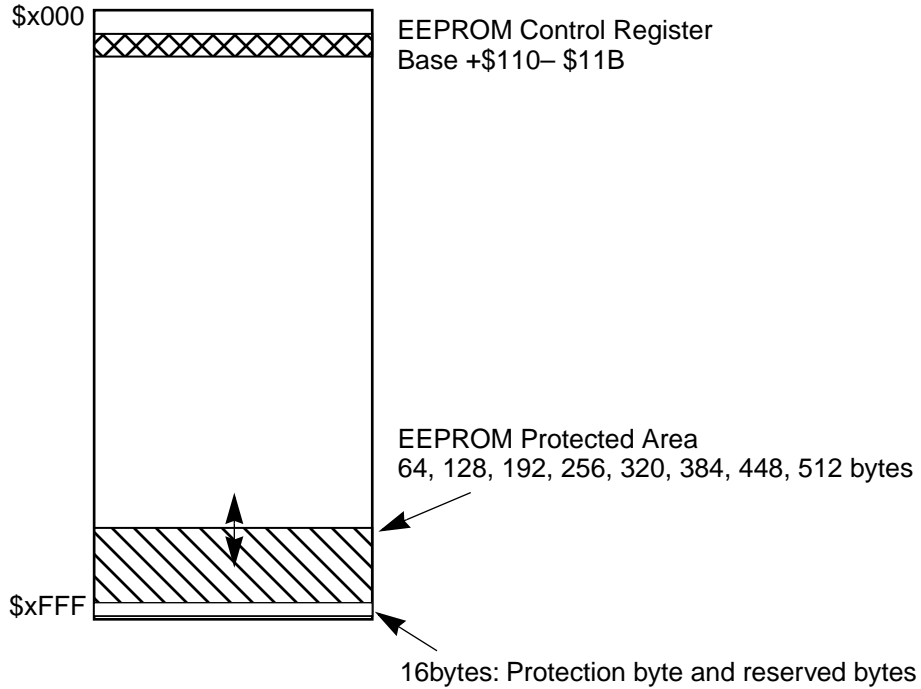

Figure 22 EEPROM Data Memory Map

EEPROM Protection Option Fields

The EEPROM block reserves one byte, \$xFFD as a protection byte which is loaded to the EPROT register on reset.

Register Memory Map

Freescale Semiconductor, Inc.

Register name		Bit 7	6	5	4	3	2	1	Bit 0	Addr. Offset
ECLKDIV	Read:	EDIVLD	PRDIV8	EDIV5	EDIV4	EDIV3	EDIV2	EDIV1	EDIV0	\$0000
	Write:									
Unused	Read:	0	0	0	0	0	0	0	0	\$0001
	Write:									
Reserved for Factory Test	Read:	0	0	0	0	0	0	0	0	\$0002
	Write:									
ECNFG	Reset:									\$0003
	Read:	CBEIE	CCIE	0	0	0	0	0	0	
EPROT	Write:									\$0004
	Read:	EPOPEN	F	F	F	EPDIS	EP2	EP1	EP0	
ESTAT	Write:									\$0005
	Read:	CBEIF	CCIF	PVIOL	ACCERR	0	BLANK	0	0	
ECMD	Write:									\$0006
	Read:	0			0	0		0		
Reserved for Factory Test	Write:		ERASE	PROG			ERVER		MASS	\$0007
	Read:	0	0	0	0	0	0	0	0	
Reserved for Factory Test	Write:									\$0008
	Read:	0	0	0	0	0	0	0	0	
Reserved for Factory Test	Write:									\$0009
	Read:	0	0	0	0	0	0	0	0	
Reserved for Factory Test	Write:									\$000A
	Read:	0	0	0	0	0	0	0	0	
Reserved for Factory Test	Write:									\$000B
	Read:	0	0	0	0	0	0	0	0	

= Unimplemented or reserved

Figure 23 EEPROM Control Register Map

NOTE: *Register Address = Base Address + Address Offset, where the Base Address is defined at the MCU level and the Address Offset is defined at the module level.*

Functional Description

All internal program and erase timings are handled by a state machine. The timebase is derived from the oscillator clock OSCCLK via a programmable down counter. The command register as well as the associated address and data registers operate as a buffer and a register (2-stage FIFO), so that a new command along with the necessary data and address can be stored to the buffers while the previous command is still in progress. Buffers empty situation as well as command completion are signalled by flags in the status register. Interrupts will be generated if enabled.

Program and Erase Procedures

Prior to issuing any program or erase commands it is first necessary to program the ECLKDIV register to divide the oscillator clock to within the 150KHz to 200KHz range. Program and erase commands will not function if this register has not been initialized. See ECLKDIV register description for further details.

A Command State Machine is used to supervise the command sequence.

The CBEIF flag should be tested to ensure that the address, data and command buffers are empty. If so, the command sequence can be started. The 3-step command sequence must be strictly adhered to and no intermediate writes to EEPROM registers are permitted between the 3 steps. The command sequence is as follows:

1. Write an aligned data word (16-bits) to be programmed to the EEPROM address space between \$x000 and \$xFFF. The address and data will be stored in internal buffers. For program, all address bits are valid. For erase, the value of the data bytes is don't care. For mass erase the address can be anywhere in the available address space of the 4k byte block to be erased. For sector erase the address bits 1:0 are don't cared.
2. Write the program or erase command to the command buffer.
3. Reset CBEIF flag by writing a "1". This will launch the command. The ACCERR and PVIOL flags should be tested to ensure the command sequence was valid. Five cycles after the CBEIF flag is cleared the CCIF flag will be cleared by hardware indicating that the command was successfully launched. The CBEIF flag will be set again indicating the address, data and command buffers are ready for a new command sequence to begin.

The completion of the command is indicated by the CCIF flag setting (Command Complete Interrupt Flag)

The Command State Machine will flag errors in program or erase sequences by means of the ACCERR (access error) and PVIOL (protection violation) flags in the FSTAT register. An erroneous command sequence will immediately abort and set the appropriate flag. The user has then to clear the ACCERR or PVIOL flags before being able to commence another command sequence.

The ACCERR flag will be set during the command sequence if any of the following illegal operations are performed. Such operations will cause the command sequence to immediately abort:

1. Writing to the EEPROM address space before initializing ECLKDIV.
2. Writing a misaligned word or a byte to the EEPROM address space.
3. Writing to the EEPROM address space while CBEIF is not set.
4. Writing a second aligned word to the EEPROM address space before executing a program or erase command on the previously written word.
5. Writing to any EEPROM register other than ECMD after writing an aligned word to the EEPROM address space.

6. Writing a second command to the ECMD register before executing the previously written command.
7. Writing a MASS erase command to ECMD while any protection is enabled. See EPROT register description.
8. Writing a SECTOR erase command to ECMD while protection is enabled for that sector. See EPROT register description.
9. Writing to any EEPROM register other than ESTAT (to clear CBEIF) after writing to the command register.
10. Reading from the EEPROM array while a command sequence is being entered or a program or erase command is being executed (i.e. CCIF not set). Such a read access returns non valid data.

NOTE: *By writing a 0 to the CBEIF flag the command sequence can be aborted after the aligned word write to the flash address space or after writing a command to the ECMD register and before the command is launched.*

The PVIOL flag will be set after the aligned write to the EEPROM address space if an attempt to program or erase a protected area of the EEPROM array is made. Such an operation will cause the command sequence to immediately abort. The user must clear the PVIOL flag before being able to commence another command sequence.

Register Descriptions

NOTE: All bits of all registers in this module are completely synchronous to internal clocks during a register read.

ECLKDIV — EEPROM Clock Divider Register.

Address Offset: \$0000

	Bit 7	6	5	4	3	2	1	Bit 0
Read:	EDIVLD	PRDIV8	EDIV5	EDIV4	EDIV3	EDIV2	EDIV1	EDIV0
Write:								
Reset:	0	0	0	0	0	0	0	0

= Reserved or unimplemented

Read: Anytime

Write: Once in normal modes, anytime in special modes

EDIVLD — EEPROM Clock Divider Loaded

This bit is set when the ECLKDIV register is written to. If this bit is “0” the register has not been written since the last reset. Trying to program or erase the EEPROM without having written to this register previously will result in an access error and the command will not be executed.

1 = Register has been written to since the last reset.

0 = Register has not been written to since the last reset.

PRDIV8 — Enable Prescaler by 8

1 = Enables a prescaler by 8 before feeding into the ECLKDIV divider.

0 = OSCCLK is directly fed into the ECLKDIV divider.

EDIV[5:0] — EEPROM Clock Divider

The combination of FDIV8 and EDIV[5:0] is used to divide the oscillator clock down to a frequency of 150KHz - 200KHz. This resulting clock, ECLK, is used to drive the program and erase state

machines for the EEPROM.

For frequencies of OSCCLK > 12.8MHz the Prescaler bit FDIV8 must be turned on.

ECLKDIV must be chosen such that the following equation is valid.

$$\text{If FDIV8} == 1 \text{ then CLK} = \text{OSCCLK} / 8, \text{ else CLK} = \text{OSCCLK}$$

$$\text{ECLKDIV} = \text{INT} (\text{CLK}[\text{KHz}] / 200\text{KHz})$$

The clock to the EEPROM timing control is therefore:

$$\text{ECLK} = \text{CLK} / (\text{EDIV}[5:0] + 1)$$

$$150\text{KHz} < \text{ECLK} \leq 200\text{KHz}$$

For example, if OSCCLK = 950KHz, ECLKDIV should be set to 4 and PRDIV8 set to 0. The resulting ECLK is 190KHz. As a result the EEPROM timings are increased by:

$$(200 - 190) / 200 \times 100\% = 5\%$$

Remark: INT means rounding towards 0.

Example: INT(950KHz/200KHz) = 4.

WARNING: *Programming the EEPROM with OSCCLK < 500KHz should be avoided. Setting ECLKDIV to a value such that ECLK < 150KHz can destroy the EEPROM due to overstress. Setting ECLKDIV to a value such that ECLK > 200KHz can result in improperly programmed memory cells.*

NOTE: *Command execution time will increase proportionally with the period of ECLK.*

Table 36 Example ECLKDIV settings

Oscillator Frequency	PRDIV	EDIV[5:0]	ECLK Frequency	ECLK Period
1.0MHz	0	000100	200KHz	5us
2.0MHz	0	001001	200KHz	5us
4.0MHz	0	010011	200KHz	5us
8.0MHz	0	100111	200KHz	5us
16.0MHz	1	001001	200KHz	5us

**ECNFG — EEPROM
Configuration
Register**

Address Offset: \$0003

	Bit 7	6	5	4	3	2	1	Bit 0
Read:	CBEIE	CCIE	0	0	0	0	0	0
Write:								
Reset:	0	0	0	0	0	0	0	0

= Reserved or unimplemented

Read: Anytime
Write: Anytime

This register enables the interrupts

CBEIE — Command Buffers Empty Interrupt Enable

This bit enables the interrupts in case of an empty address, data and command buffers.

- 1 = An interrupt will be requested whenever the CBEIF flag is set
- 0 = Command Buffers Empty Interrupts disabled

CCIE — Command Complete Interrupt Enable

This bit enables the interrupts in case of all commands being completed.

- 1 = An interrupt will be requested whenever the CCIF flag is set
- 0 = Command Complete Interrupts disabled

EEPROM 4K

EPROT — EEPROM

Protection

Register

Address Offset: \$0004

	Bit 7	6	5	4	3	2	1	Bit 0
Read:	EPOPEN	F	F	F	EPDIS	EP2	EP1	EP0
Write:								
Reset:	F	F	F	F	F	F	F	F

 = Reserved or unimplemented

Read: Anytime

Write: Only in special modes

This register is banked.

The EEPROM protection registers are loaded during the reset sequence from address $\$_FFD$ as indicated by the “F” in the reset row of the register diagram. This register determines whether the whole block or a subsection of the block is protected against accidental program or erase. The protected area grows downwards from $\$xFFF$. This area may be used to keep critical parameters. Trying to alter the protected area will result in a protect violation error and bit PVIOL will be set in the EEPROM Status Register ESTAT. A mass erase of the full 4k byte block is only possible when EPDIS is set.

In order to change the EEPROM protection in special modes, the protection register can be written directly.

In order to change the protection in user mode the EEPROM location $\$_FFD$ has to be re-programmed and the MCU reset to reload the EPROT register from that EEPROM location.

The size of the protected range is determined by EP[2:0]. The protection is disabled by the bit EPDIS.

EPOPEN — Opens the EEPROM block or a subsection of it for program or erase.

1 = The EEPROM block or subsections are enabled to program or erase.

0 = The whole EEPROM block is protected. In this case the other bits within the protect register are don't care.

EPDIS — EEPROM Protection disable

This bit determines whether there is a protected area at the higher end of the EEPROM block address map.

1 = Protection disabled

0 = Protection enabled

EP[2:0] — EEPROM Protection address size

These 3 bits determine the size of the protected area.

Table 37 Address Range Protection

EP[2:0]	Protected Address Range	Protected Size
000	\$_FC0 - \$_FFF	64 bytes
001	\$_F80 - \$_FFF	128 bytes
010	\$_F40 - \$_FFF	192 bytes
011	\$_F00 - \$_FFF	256 bytes
100	\$_EC0 - \$_FFF	320 bytes
101	\$_E80 - \$_FFF	384 bytes
110	\$_E40 - \$_FFF	448 bytes
111	\$_E00 - \$_FFF	512 bytes

The EEPROM holds a field of 16-bytes consisting of 1 protection byte and 15 reserved bytes. The layout of this field is:

Table 38 Flash 0 Protection/Security Field

Address	Size	Description
\$_FF0 - \$_FFC	13	Reserved
\$_FFD	1	Protection byte for EEPROM
\$_FFE - \$_FFF	2	Reserved

EEPROM 4K

**ESTAT — EEPROM
Status Register**

Address Offset: \$0005

	Bit 7	6	5	4	3	2	1	Bit 0
Read:	CBEIF	CCIF	PVIOL	ACCERR	0	BLANK	0	0
Write:								
Reset:	1	1	0	0	0	0	0	0

= Reserved or unimplemented

Read: Anytime
Write: Anytime to clear flags

The bits in this register are set by various conditions.

CBEIF — Command Buffer Empty Interrupt Flag

Indicates that the address, data and command buffer are empty so that a new command sequence can be started. The flag is cleared by writing a “1”. By clearing the flag the command sequence is launched. Writing a “0” aborts a command sequence that has not yet been launched and sets the ACCERR flag.

- 1 = Buffers are ready to accept a new command
- 0 = Buffers are full

CCIF — Command Complete Interrupt Flag

Indicates that there are no more commands pending. The flag is cleared by hardware. Writing has no effect.

- 1 = All commands are completed
- 0 = Command in progress

PVIOL — Protection violation

Indicates an attempt was made to program or erase an address in a protected memory area. A subsequent program or erase command cannot be executed while this flag is set. The flag is cleared by writing a “1”. Writing a “0” has no effect. The flag is also cleared by writing a new, valid command after CBEIF is cleared or when CCIF is clear.

- 1 = A protection violation has occurred.
- 0 = No violation occurred

ACCERR — Access error

Indicates an illegal access to the EEPROM block or violation of the defined command sequence. This can be:

1. Writing to the EEPROM address space before initializing ECLKDIV.
2. Writing a misaligned word or a byte to the EEPROM address space.
3. Writing to the EEPROM address space while CBEIF is not set.
4. Writing a second aligned word to the EEPROM address space before executing a program or erase command on the previously written word.
5. Writing to any EEPROM register other than ECMD after writing an aligned word to the EEPROM address space.
6. Writing a second command to the ECMD register before executing the previously written command.
7. Writing a MASS erase command to ECMD while any protection is enabled. See EPROT register description.
8. Writing a sector erase command to ECMD while protection is enabled for that sector. See EPROT register description.
9. Writing to any EEPROM register other than ESTAT (to clear CBEIF) after writing to the command register.
10. Reading from the EEPROM block while a command sequence is being entered or a program or erase command is being executed. (i.e. CCIF not set). Such a read access returns non valid data

The flag is cleared by writing a “1”. Writing a “0” has no effect.

1 = Access error has occurred.

0 = No failure.

BLANK — Blank Verify Flag

Indicates that the EEPROM block is fully erased in response to an Erase- Verify command. The flag is cleared by writing a “1”. Writing a “0” has no effect.

1 = EEPROM block fully erased.

0 = EEPROM block not fully erased.

BITS[1:0] — These bits are reserved for factory testing.

EEPROM 4K

**ECMD — EEPROM
Command Buffer
and Register**

Address Offset: \$0006

	Bit 7	6	5	4	3	2	1	Bit 0
Read:	0			0	0		0	
Write:		ERASE	PROG			ERVER		MASS
Reset:	0	0	0	0	0	0	0	0

= Reserved or unimplemented

Read: Anytime

Write: After aligned write to the EEPROM address space in the command sequence. (See PVIOL description in ESTAT register)

This register is buffered. The bits 6,5,2 and 0 are associated with erase, program and verify commands. The buffer is always read. The register cannot be read.

ERASE — Erase EEPROM

Erases a EEPROM sector or the whole EEPROM depending on the MASS bit. Trying to erase a sector located in a protected area will result in a protection error indicated by PVIOL set.

- 1 = Perform a sector erase if MASS=0 or a mass erase if MASS=1.
- 0 = -

PROG — Word programming

Trying to program a word located in a protected area will result in a protection error indicated by PVIOL set.

- 1 = Program memory
- 0 = -

ERVER — Enable Erase Verify

Verifies the EEPROM block is fully erased. A successful verification will set the BLANK bit in the ESTAT register.

- 1 = Perform an erase verify after mass erase.
- 0 = -

MASS — Enables Mass Erase

Perform a mass erase of the selected 4k byte block. This bit works in conjunction with the ERASE bit. If any protection is active on the selected block, mass erase has no effect and PVIOL is set.

- 1 = Perform a mass erase of the whole block
- 0 = Perform sector erase

Table 39 Valid Commands

Command	Meaning	Remarks
\$20	Memory Program	Program 1 word (2 bytes)
\$40	Sector Erase	Erase 4 bytes
\$41	Mass Erase	Erase all 4k bytes
\$05	Erase Verify	Verify all 4k bytes are erased
other	Illegal	Generate an access error

The registers \$0007 to \$000B are reserved for factory testing and are not available to the user.

External Pin Descriptions

This module does not have external pins relevant for the user.

Reset Initialization

Out of reset the module is immediately accessible operating in read mode.

If a reset occurs while any command is in progress that command will be immediately aborted. The state of the word being programmed or the sector / block being erased is not guaranteed.

Modes of Operation

Security Modes There are no security modes for the EEPROM.

Low Power Options When the array or the registers are not being accessed clocking to the register block is shut off to save power. The only exceptions to this are the flag bits in the ESTAT register which are updated by internal state machines.

Run Mode No special current saving modes available.

Wait Mode When the MCU enters WAIT mode and any command is active (CCIF = 0) the command will be completed. If enabled, the CCIF interrupt can be used to waken the MCU out of Wait mode.

Stop Mode No low power options exist for this module in stop mode. If a command is active (CCIF = 0) when the MCU enters the STOP mode, the command will be aborted and the and the high voltage circuitry to the EEPROM array will be switched off.

Interrupt Operation

This module can generate an interrupt when all commands are completed or the command buffer is empty.

Interrupt Sources

Table 40 EEPROM 4K Interrupt Sources

Interrupt Source	Interrupt Flag	Local Enable	Global (CCR) Mask
EEPROM Address, Data and Command Buffers empty	CBEIF EEPROM	CBEIE	I Bit
All Commands are completed	CCIF EEPROM	CCIE	I Bit

NOTE: *Vector addresses and their relative interrupt priority are determined at the MCU level.*

Recovery from STOP or WAIT

The module can recover the part from WAIT, if the interrupts are enabled.

There is no capability to recover from STOP.



Port Integration Module

Contents

Overview	213
Block Diagram	215
Register Map	217
External Pin Descriptions	216
80 Pin QFP bond-out version	216
Register Map	217
Register Descriptions	222
Reset Initialization	251
Functional Description	251
Low Power Options	255
Interrupt Operation	256

Overview

The Port Integration Module establishes the interface between the peripheral modules and the I/O pins for all ports except A, B, E and K. Those ports are handled by the HC12 multiplexed bus interface and described in [Bus Control and Input/Output](#), due to their tight link with the external bus interface and special modes.

The two 8-bit ports associated with the ATD are included in the ATD module due to their sensitivity to electrical noise, requiring special care on routing and design.

This section covers port T connected to the timer module, the serial port S associated with 2 SCI and 1 SPI module, the multiplex ports M, associated with 4 CAN and 1 BDLC module, and P, connected to the PWM and 2 SPI modules, the standard I/O port H, and finally the port J

associated with the fifth CAN module and the IIC interface¹. Ports P, H and J can also be used as external interrupt sources.

Each I/O pin can be configured by several registers: Input/output selection, drive strength reduction, enable and select of pull resistors, interrupt enable and status flags.

The port integration module is device dependant which is reflected in its naming.

A standard port has the following minimum features:

- Input/output selection
- 5V output drive with two selectable drive strength
- 5V digital and analog input
- Input with selectable pull-up or pull-down device

Optional features:

- Open drain for wired-or connections
- Interrupt inputs with glitch filtering

Table 41 Port Reset State and Priority Summary

Port	Reset States					Priority
	Data Direction	Pull Mode	Red. Drive	Wired-Or Mode	Inter-rupt	
T	input	hiz	disabled	n/a	n/a	ECT > GPIO
S	input	pull-up	disabled	disabled	n/a	SCI, SPI > GPIO
M	input	hiz	disabled	disabled	n/a	CAN > BDLC > GPIO
P	input	hiz	disabled	n/a	disabled	PWM > SPI > GPIO
H	input	hiz	disabled	n/a	disabled	GPIO
J	input	pull-up	disabled	n/a	disabled	CAN > IIC > GPIO

1. The port control register addresses are allocated in the order of their most likely occurrence, i.e. almost all STAR12 derivatives will have a timer port, and a very limited number will have a IIC module. This allows best consistency in the address allocation.

Block Diagram

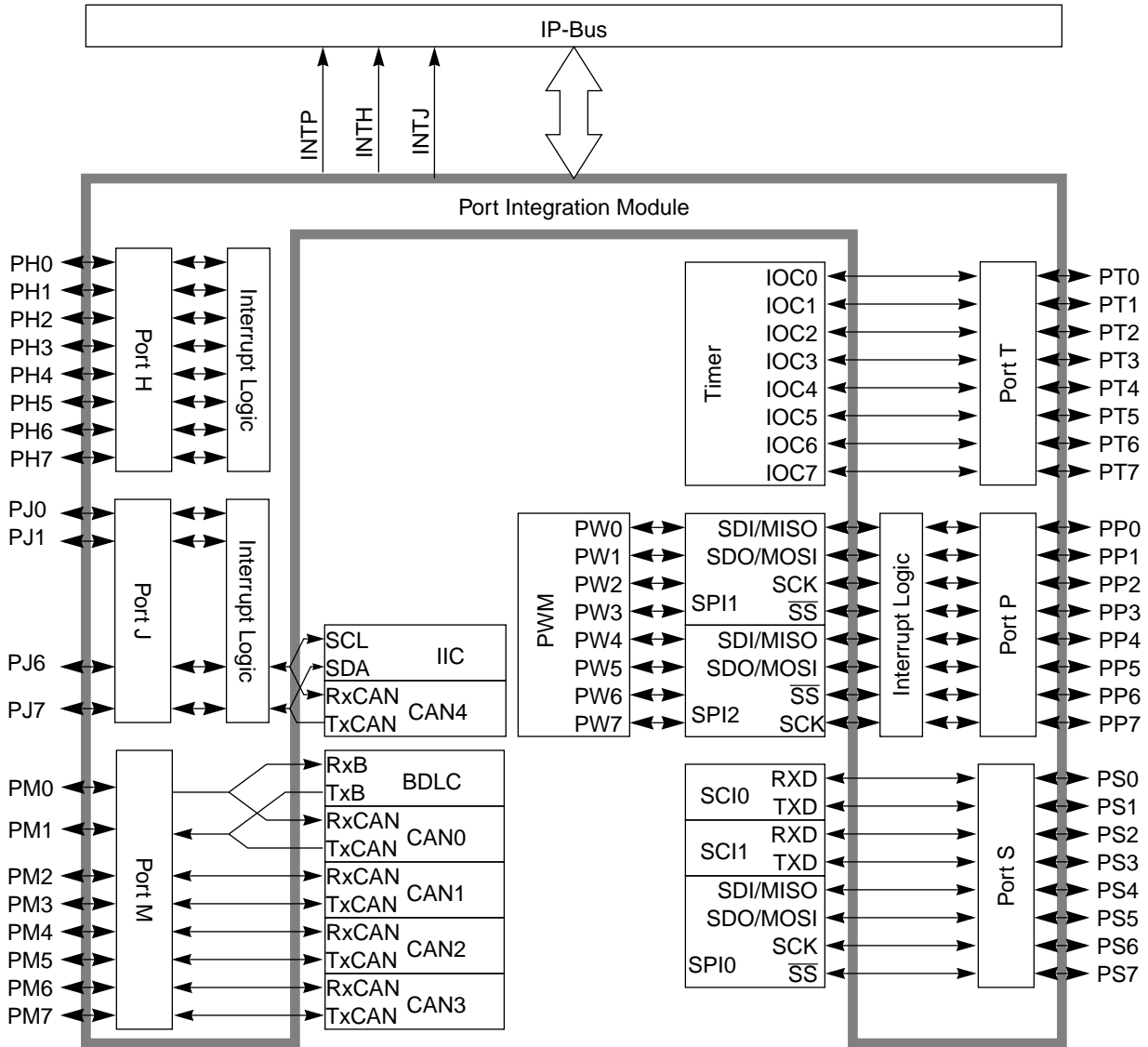

Figure 24 PIM_9DP256 Block Diagram

External Pin Descriptions

All ports start up as general purpose inputs on reset.

80 Pin QFP bond-out version

In case the port pins are not bonded out in the chosen package the user should initialize the registers to be inputs with enabled pull resistance to avoid excess current consumption. This applies to the following pins:

- All port K and H.
- Port PP6, PJ1–0, PM7–4.
- PAD15–8. The A/D converter associated with those pins (ATD1) should be disabled.

Register Map

Register name		Bit 7	6	5	4	3	2	1	Bit 0	Addr. Offset
PTT	Read:	PTT7	PTT6	PTT5	PTT4	PTT3	PTT2	PTT1	PTT0	\$0000
	Write:									
PTIT	Read:	PTIT7	PTIT6	PTIT5	PTIT4	PTIT3	PTIT2	PTIT1	PTIT0	\$0001
	Write:									
DDRT	Read:	DDRT7	DDRT6	DDRT5	DDRT4	DDRT3	DDRT2	DDRT1	DDRT0	\$0002
	Write:									
RDRT	Read:	RDRT7	RDRT6	RDRT5	RDRT4	RDRT3	RDRT2	RDRT1	RDRT0	\$0003
	Write:									
PERT	Read:	PERT7	PERT6	PERT5	PERT4	PERT3	PERT2	PERT1	PERT0	\$0004
	Write:									
PPST	Read:	PPST7	PPST6	PPST5	PPST4	PPST3	PPST2	PPST1	PPST0	\$0005
	Write:									
Unimplemented	Read:	0	0	0	0	0	0	0	0	\$0006
	Write:									
Unimplemented	Read:	0	0	0	0	0	0	0	0	\$0007
	Write:									
PTS	Read:	PTS7	PTS6	PTS5	PTS4	PTS3	PTS2	PTS1	PTS0	\$0008
	Write:									
PTIS	Read:	PTIS7	PTIS6	PTIS5	PTIS4	PTIS3	PTIS2	PTIS1	PTIS0	\$0009
	Write:									
DDRS	Read:	DDRS7	DDRS6	DDRS5	DDRS4	DDRS3	DDRS2	DDRS1	DDRS0	\$000A
	Write:									
RDRS	Read:	RDRS7	RDRS6	RDRS5	RDRS4	RDRS3	RDRS2	RDRS1	RDRS0	\$000B
	Write:									
PERS	Read:	PERS7	PERS6	PERS5	PERS4	PERS3	PERS2	PERS1	PERS0	\$000C
	Write:									

= Unimplemented or reserved

Figure 25 PIM_912DP256 Register Map

Port Integration Module

Register name		Bit 7	6	5	4	3	2	1	Bit 0	Addr. Offset
PPSS	Read: Write:	PPSS7	PPSS6	PPSS5	PPSS4	PPSS3	PPSS2	PPSS1	PPSS0	\$000D
WOMS	Read: Write:	WOMS7	WOMS6	WOMS5	WOMS4	WOMS3	WOMS2	WOMS1	WOMS0	\$000E
Unimplemented	Read: Write:	0	0	0	0	0	0	0	0	\$000F
PTM	Read: Write:	PTM7	PTM6	PTM5	PTM4	PTM3	PTM2	PTM1	PTM0	\$0010
PTIM	Read: Write:	PTIM7	PTIM6	PTIM5	PTIM4	PTIM3	PTIM2	PTIM1	PTIM0	\$0011
DDRM	Read: Write:	DDRM7	DDRM6	DDRM5	DDRM4	DDRM3	DDRM2	DDRM1	DDRM0	\$0012
RDRM	Read: Write:	RDRM7	RDRM6	RDRM5	RDRM4	RDRM3	RDRM2	RDRM1	RDRM0	\$0013
PERM	Read: Write:	PERM7	PERM6	PERM5	PERM4	PERM3	PERM2	PERM1	PERM0	\$0014
PPSM	Read: Write:	PPSM7	PPSM6	PPSM5	PPSM4	PPSM3	PPSM2	PPSM1	PPSM0	\$0015
WOMM	Read: Write:	WOMM7	WOMM6	WOMM5	WOMM4	WOMM3	WOMM2	WOMM1	WOMM0	\$0016
Unimplemented	Read: Write:	0	0	0	0	0	0	0	0	\$0017
PTP	Read: Write:	PTP7	PTP6	PTP5	PTP4	PTP3	PTP2	PTP1	PTP0	\$0018
PTIP	Read: Write:	PTIP7	PTIP6	PTIP5	PTIP4	PTIP3	PTIP2	PTIP1	PTIP0	\$0019

= Unimplemented or reserved

Figure 25 PIM_912DP256 Register Map

Register name		Bit 7	6	5	4	3	2	1	Bit 0	Addr. Offset
DDRP	Read:	DDRP7	DDRP6	DDRP5	DDRP4	DDRP3	DDRP2	DDRP1	DDRP0	\$001A
	Write:									
RDRP	Read:	RDRP7	RDRP6	RDRP5	RDRP4	RDRP3	RDRP2	RDRP1	RDRP0	\$001B
	Write:									
PERP	Read:	PERP7	PERP6	PERP5	PERP4	PERP3	PERP2	PERP1	PERP0	\$001C
	Write:									
PPSP	Read:	PPSP7	PPSP6	PPSP5	PPSP4	PPSP3	PPSP2	PPSP1	PPSP0	\$001D
	Write:									
PIEP	Read:	PIEP7	PIEP6	PIEP5	PIEP4	PIEP3	PIEP2	PIEP1	PIEP0	\$001E
	Write:									
PIFP	Read:	PIFP7	PIFP6	PIFP5	PIFP4	PIFP3	PIFP2	PIFP1	PIFP0	\$001F
	Write:									
PTH	Read:	PTH7	PTH6	PTH5	PTH4	PTH3	PTH2	PTH1	PTH0	\$0020
	Write:									
PTIH	Read:	PTIH7	PTIH6	PTIH5	PTIH4	PTIH3	PTIH2	PTIH1	PTIH0	\$0021
	Write:									
DDRH	Read:	DDRH7	DDRH6	DDRH5	DDRH4	DDRH3	DDRH2	DDRH1	DDRH0	\$0022
	Write:									
RDRH	Read:	RDRH7	RDRH6	RDRH5	RDRH4	RDRH3	RDRH2	RDRH1	RDRH0	\$0023
	Write:									
PERH	Read:	PERH7	PERH6	PERH5	PERH4	PERH3	PERH2	PERH1	PERH0	\$0024
	Write:									
PPSH	Read:	PPSH7	PPSH6	PPSH5	PPSH4	PPSH3	PPSH2	PPSH1	PPSH0	\$0025
	Write:									
PIEH	Read:	PIEH7	PIEH6	PIEH5	PIEH4	PIEH3	PIEH2	PIEH1	PIEH0	\$0026
	Write:									
PIFH	Read:	PIFH7	PIFH6	PIFH5	PIFH4	PIFH3	PIFH2	PIFH1	PIFH0	\$0027
	Write:									

= Unimplemented or reserved

Figure 25 PIM_912DP256 Register Map

Port Integration Module

Register name		Bit 7	6	5	4	3	2	1	Bit 0	Addr. Offset
PTJ	Read:	PTJ7	PTJ6	0	0	0	0	PTJ1	PTJ0	\$0028
	Write:									
PTIJ	Read:	PTIJ7	PTIJ6	0	0	0	0	PTIJ1	PTIJ0	\$0029
	Write:									
DDRJ	Read:	DDRJ7	DDRJ6	0	0	0	0	DDRJ1	DDRJ0	\$002A
	Write:									
RDRJ	Read:	RDRJ7	RDRJ6	0	0	0	0	RDRJ1	RDRJ0	\$002B
	Write:									
PERJ	Read:	PERJ7	PERJ6	0	0	0	0	PERJ1	PERJ0	\$002C
	Write:									
PPSJ	Read:	PPSJ7	PPSJ6	0	0	0	0	PPSJ1	PPSJ0	\$002D
	Write:									
PIEJ	Read:	PIEJ7	PIEJ6	0	0	0	0	PIEJ1	PIEJ0	\$002E
	Write:									
PIFJ	Read:	PIFJ7	PIFJ6	0	0	0	0	PIFJ1	PIFJ0	\$002F
	Write:									
Unimplemented	Read:	0	0	0	0	0	0	0	0	\$0030
	Write:									
Unimplemented	Read:	0	0	0	0	0	0	0	0	\$0031
	Write:									
Unimplemented	Read:	0	0	0	0	0	0	0	0	\$0032
	Write:									
Unimplemented	Read:	0	0	0	0	0	0	0	0	\$0033
	Write:									
Unimplemented	Read:	0	0	0	0	0	0	0	0	\$0034
	Write:									

= Unimplemented or reserved

Figure 25 PIM_912DP256 Register Map

Register name		Bit 7	6	5	4	3	2	1	Bit 0	Addr. Offset
Unimplemented	Read:	0	0	0	0	0	0	0	0	\$0035
	Write:									
Unimplemented	Read:	0	0	0	0	0	0	0	0	\$0036
	Write:									
Unimplemented	Read:	0	0	0	0	0	0	0	0	\$0037
	Write:									
Unimplemented	Read:	0	0	0	0	0	0	0	0	\$0038
	Write:									
Unimplemented	Read:	0	0	0	0	0	0	0	0	\$0039
	Write:									
Unimplemented	Read:	0	0	0	0	0	0	0	0	\$003A
	Write:									
Unimplemented	Read:	0	0	0	0	0	0	0	0	\$003B
	Write:									
Unimplemented	Read:	0	0	0	0	0	0	0	0	\$003C
	Write:									
Unimplemented	Read:	0	0	0	0	0	0	0	0	\$003D
	Write:									
Unimplemented	Read:	0	0	0	0	0	0	0	0	\$003E
	Write:									
Unimplemented	Read:	0	0	0	0	0	0	0	0	\$003F
	Write:									

= Unimplemented or reserved

Figure 25 PIM_912DP256 Register Map

NOTE: *Register Address = Base Address + Address Offset, where the Base Address is defined at the MCU level and the Address Offset is defined at the module level.*

Register Descriptions

The following table summarizes the effect on the various configuration bits, data direction (DDR), output level (I/O), reduced drive (RDR), pull enable (PE), polarity select (PS) and interrupt enable (IE) for the ports. The configuration bit PS is used for two purposes:

1. Configure the sensitive interrupt edge (rising or falling), if interrupt is enabled.
2. Select either a pull-up or pull-down device if PE is active.

Table 42 Pin Configuration Summary

DDR	IO	RDR	PE	PS	IE ⁽¹⁾	Function	Pull Device	Interrupt
0	X	X	0	X	0	Input	Disabled	Disabled
0	X	X	1	0	0	Input	Pull Up	Disabled
0	X	X	1	1	0	Input	Pull Down	Disabled
0	X	X	0	0	1	Input	Disabled	falling edge
0	X	X	0	1	1	Input	Disabled	rising edge
0	X	X	1	0	1	Input	Pull Up	falling edge
0	X	X	1	1	1	Input	Pull Down	rising edge
1	0	0	X	X	0	Output, full drive to 0	Disabled	Disabled
1	1	0	X	X	0	Output, full drive to 1	Disabled	Disabled
1	0	1	X	X	0	Output, reduced drive to 0	Disabled	Disabled
1	1	1	X	X	0	Output, reduced drive to 1	Disabled	Disabled
1	0	0	X	0	1	Output, full drive to 0	Disabled	falling edge
1	1	0	X	1	1	Output, full drive to 1	Disabled	rising edge
1	0	1	X	0	1	Output, reduced drive to 0	Disabled	falling edge
1	1	1	X	1	1	Output, reduced drive to 1	Disabled	rising edge

1. Applicable only on port P, H and J.

NOTE: *All bits of all registers in this module are completely synchronous to internal clocks during a register read.*

**Port T I/O
Register (PTT)**

Address Offset: \$0000

	Bit 7	6	5	4	3	2	1	Bit 0
Read:	PTT7	PTT6	PTT5	PTT4	PTT3	PTT2	PTT1	PTT0
Write:								
ECT:	I/OC7	I/OC6	I/OC5	I/OC4	I/OC3	I/OC2	I/OC1	I/OC0
Reset:	0	0	0	0	0	0	0	0

 = Reserved or unimplemented

Read: Anytime.

Write: Anytime.

If the data direction bits of the associated I/O pins are set to 1, a read returns the value of the port register, otherwise the value at the pins is read.

**Port T Input
Register (PTIT)**

Address Offset: \$0001

	Bit 7	6	5	4	3	2	1	Bit 0
Read:	PTIT7	PTIT6	PTIT5	PTIT4	PTIT3	PTIT2	PTIT1	PTIT0
Write:								
Reset:	-	-	-	-	-	-	-	-

 = Reserved or unimplemented

Read: Anytime.

Write: Never; writes to this register have no effect.

This register always reads back the status of the associated pins. This can also be used to detect overload or short circuit conditions on output pins.

Port Integration Module

**Port T Data
Direction Register
(DDRT)**

Address Offset: \$0002

	Bit 7	6	5	4	3	2	1	Bit 0
Read:	DDRT7	DDRT6	DDRT5	DDRT4	DDRT3	DDRT2	DDRT1	DDRT0
Write:								
Reset:	0	0	0	0	0	0	0	0

 = Reserved or unimplemented

Read: Anytime.

Write: Anytime.

This register configures each port T pin as either input or output. The ECT forces the I/O state to be an output for each timer port associated with an enabled output compare. In these cases the data direction bits will not change.

The DDRT bits revert to controlling the I/O direction of a pin when the associated timer output compare is disabled.

The timer input capture always monitors the state of the pin.

DDRT[7:0] — Data Direction Port T

1 = Associated pin is configured as output.

0 = Associated pin is configured as input.

Due to internal synchronization circuits, it can take up to 2 bus cycles until the correct value is read on PTT or PTIT registers, when changing the DDRT register.

Port T Reduced Drive Register (RDRT)

Address Offset: \$0003

	Bit 7	6	5	4	3	2	1	Bit 0
Read:	RDRT7	RDRT6	RDRT5	RDRT4	RDRT3	RDRT2	RDRT1	RDRT0
Write:								
Reset:	0	0	0	0	0	0	0	0

 = Reserved or unimplemented

Read: Anytime.

Write: Anytime.

This register configures the drive strength of each port T output pin as either full or reduced. If the port is used as input this bit is ignored.

RDRT[7:0] — Reduced Drive Port T

1 = Associated pin drives at about 1/3 of the full drive strength.

0 = Full drive strength at output.

Port T Pull Device Enable Register (PERT)

Address Offset: \$0004

	Bit 7	6	5	4	3	2	1	Bit 0
Read:	PERT7	PERT6	PERT5	PERT4	PERT3	PERT2	PERT1	PERT0
Write:								
Reset:	0	0	0	0	0	0	0	0

 = Reserved or unimplemented

Read: Anytime.

Write: Anytime.

This register configures whether a pull-up or a pull-down device is activated, if the port is used as input. This bit has no effect if the port is used as output. Out of reset no pull device is enabled.

PERT[7:0] — Pull Device Enable Port T

1 = Either a pull-up or pull-down device is enabled.

0 = Pull-up or pull-down device is disabled.

Port Integration Module

**Port T Polarity
Select Register (PPST)**

Address Offset: \$0005

	Bit 7	6	5	4	3	2	1	Bit 0
Read:	PPST7	PPST6	PPST5	PPST4	PPST3	PPST2	PPST1	PPST0
Write:								
Reset:	0	0	0	0	0	0	0	0

 = Reserved or unimplemented

Read: Anytime.

Write: Anytime.

This register selects whether a pull-down or a pull-up device is connected to the pin.

PPST[7:0] — Pull Select Port T

1 = A pull-down device is connected to the associated port T pin, if enabled by the associated bit in register PERT and if the port is used as input.

0 = A pull-up device is connected to the associated port T pin, if enabled by the associated bit in register PERT and if the port is used as input.

**Port S I/O Register
(PTS)**

Address Offset: \$0008

	Bit 7	6	5	4	3	2	1	Bit 0
Read:	PTS7	PTS6	PTS5	PTS4	PTS3	PTS2	PTS1	PTS0
Write:								
SPI/SCI:	$\overline{SS0}$	SCK0	MOSI0	MISO0	TxD1	RxD1	TxD0	RxD0
Reset:	0	0	0	0	0	0	0	0

 = Reserved or unimplemented

Read: Anytime.

Write: Anytime.

If the data direction bits of the associated I/O pins are set to 1, a read returns the value of the port register, otherwise the value at the pins is read.

The SPI pins (PS[7:4]) configuration is determined by several status bits in the SPI module. See [Serial Peripheral Interface \(SPI\) section for details](#).

The SCI ports associated with transmit pins 3 and 1 are configured as outputs if the transmitter is enabled.

The SCI pins associated with receive pins 2 and 0 are configured as inputs if the receiver is enabled. See [Serial Communications Interface \(SCI\) section for details](#).

Port S Input Register (PTIS)

Address Offset: \$0009

	Bit 7	6	5	4	3	2	1	Bit 0
Read:	PTIS7	PTIS6	PTIS5	PTIS4	PTIS3	PTIS2	PTIS1	PTIS0
Write:								
Reset:	-	-	-	-	-	-	-	-

 = Reserved or unimplemented

Read: Anytime.

Write: Never; writes to this register have no effect.

This register always reads back the status of the associated pins. This also can be used to detect overload or short circuit conditions on output pins.

Port S Data Direction Register (DDRS)

Address Offset: \$000A

	Bit 7	6	5	4	3	2	1	Bit 0
Read:	DDRS7	DDRS6	DDRS5	DDRS4	DDRS3	DDRS2	DDRS1	DDRS0
Write:								
Reset:	0	0	0	0	0	0	0	0

 = Reserved or unimplemented

Read: Anytime.

Write: Anytime.

This register configures each port S pin as either input or output. If SPI is enabled, the SPI determines the pin direction. *For details see [Serial Peripheral Interface \(SPI\) section](#).*

If the associated SCI transmit or receive channel is enabled this register has no effect on the pins. The pin is forced to be an output if a SCI transmit channel is enabled, it is forced to be an input if the SCI receive channel is enabled.

The DDRS bits revert to controlling the I/O direction of a pin when the associated channel is disabled.

DDRS[7:0] — Data Direction Port S

1 = Associated pin is configured as output.

0 = Associated pin is configured as input.

Due to internal synchronization circuits, it can take up to 2 bus cycles until the correct value is read on PTS or PTIS registers, when changing the DDRS register.

Port S Reduced Drive Register (RDRS)

Address Offset: \$000B

	Bit 7	6	5	4	3	2	1	Bit 0
Read:	RDRS7	RDRS6	RDRS5	RDRS4	RDRS3	RDRS2	RDRS1	RDRS0
Write:								
Reset:	0	0	0	0	0	0	0	0

 = Reserved or unimplemented

Read: Anytime.

Write: Anytime.

This register configures the drive strength of each port S output pin as either full or reduced. If the port is used as input this bit is ignored.

RDRS[7:0] — Reduced Drive Port S

1 = Associated pin drives at about 1/3 of the full drive strength.

0 = Full drive strength at output.

**Port S Pull Device
Enable Register
(PERS)**

Address Offset: \$000C

	Bit 7	6	5	4	3	2	1	Bit 0
Read:	PERS7	PERS6	PERS5	PERS4	PERS3	PERS2	PERS1	PERS0
Write:								
Reset:	1	1	1	1	1	1	1	1

 = Reserved or unimplemented

Read: Anytime.

Write: Anytime.

This register configures whether a pull-up or a pull-down device is activated, if the port is used as input or as output in wired-or (open drain) mode. This bit has no effect if the port is used as push-pull output. Out of reset a pull-up device is enabled.

PERS[7:0] — Pull Device Enable Port S

1 = Either a pull-up or pull-down device is enabled.

0 = Pull-up or pull-down device is disabled.

**Port S Polarity
Select Register
(PPSS)**

Address Offset: \$000D

	Bit 7	6	5	4	3	2	1	Bit 0
Read:	PPSS7	PPSS6	PPSS5	PPSS4	PPSS3	PPSS2	PPSS1	PPSS0
Write:								
Reset:	0	0	0	0	0	0	0	0

 = Reserved or unimplemented

Read: Anytime.

Write: Anytime.

This register selects whether a pull-down or a pull-up device is connected to the pin.

PPSS[7:0] — Pull Select Port S

- 1 = A pull-down device is connected to the associated port S pin, if enabled by the associated bit in register PERS and if the port is used as input.
- 0 = A pull-up device is connected to the associated port S pin, if enabled by the associated bit in register PERS and if the port is used as input or as wired-or output.

Port S Wired-Or Mode Register (WOMS)

Address Offset: \$000E

	Bit 7	6	5	4	3	2	1	Bit 0
Read:	WOMS7	WOMS6	WOMS5	WOMS4	WOMS3	WOMS2	WOMS1	WOMS0
Write:								
Reset:	0	0	0	0	0	0	0	0

= Reserved or unimplemented

Read: Anytime.
Write: Anytime.

This register configures the output pins as wired-or. If enabled the output is driven active low only (open-drain). A logic level of '1' is not driven. It applies also to the SPI and SCI outputs and allows a multipoint connection of several serial modules. This bit has no influence on pins used as inputs.

WOMS[7:0] — Wired-Or Mode Port S

- 1 = Output buffers operate as open-drain outputs.
- 0 = Output buffers operate as push-pull outputs.

**Port M I/O
Register (PTM)**

Address Offset: \$0010

	Bit 7	6	5	4	3	2	1	Bit 0
Read:	PTM7	PTM6	PTM5	PTM4	PTM3	PTM2	PTM1	PTM0
Write:	PTM7	PTM6	PTM5	PTM4	PTM3	PTM2	PTM1	PTM0
CAN:	TxCAN3	RxCAN3	TxCAN2	RxCAN2	TxCAN1	RxCAN1	TxCAN0	RxCAN0
J1850:							TxBDLC	RxBDLC
Reset:	0	0	0	0	0	0	0	0

 = Reserved or unimplemented

Read: Anytime.

Write: Anytime.

If the data direction bits of the associated I/O pins are set to 1, a read returns the value of the port register, otherwise the value at the pins is read.

The CAN function (TxCAN and RxCAN) takes precedence over the general purpose I/O function if the associated CAN module is enabled. See [MSCAN section](#).

The BDLC function takes precedence over the general purpose I/O function associated with if enabled. See [Byte Data Link Controller Module section](#).

If both CAN0 and BDLC are enabled the CAN functionality takes precedence.

**Port M Input
Register (PTIM)**

Address Offset: \$0011

	Bit 7	6	5	4	3	2	1	Bit 0
Read:	PTIM7	PTIM6	PTIM5	PTIM4	PTIM3	PTIM2	PTIM1	PTIM0
Write:								
Reset:	-	-	-	-	-	-	-	-

 = Reserved or unimplemented

Read: Anytime.

Write: Never; writes to this register have no effect.

Port Integration Module

This register always reads back the status of the associated pins. This can also be used to detect overload or short circuit conditions on output pins.

**Port M Data
Direction Register
(DDRM)**

Address Offset: \$0012

	Bit 7	6	5	4	3	2	1	Bit 0
Read:	DDRM7	DDRM6	DDRM5	DDRM4	DDRM3	DDRM2	DDRM1	DDRM0
Write:								
Reset:	0	0	0	0	0	0	0	0

 = Reserved or unimplemented

Read: Anytime.
Write: Anytime.

This register configures each port M pin as either input or output. The CAN/BDLC forces the I/O state to be an output for each port line associated with an enabled output (TxCAN[3:0], TxBDLC). It also forces the I/O state to be an input for each port line associated with an enabled input (RxCAN[3:0], RxBDLC). In those cases the data direction bits will not change.

The DDRM bits revert to controlling the I/O direction of a pin when the associated peripheral module is disabled.

DDRM[7:0] — Data Direction Port M

- 1 = Associated pin is configured as output.
- 0 = Associated pin is configured as input.

Due to internal synchronization circuits, it can take up to 2 bus cycles until the correct value is read on PTM or PTIM registers, when changing the DDRM register.

Port M Reduced Drive Register (RDRM)

Address Offset: \$0013

	Bit 7	6	5	4	3	2	1	Bit 0
Read:	RDRM7	RDRM6	RDRM5	RDRM4	RDRM3	RDRM2	RDRM1	RDRM0
Write:								
Reset:	0	0	0	0	0	0	0	0

 = Reserved or unimplemented

Read: Anytime.

Write: Anytime.

This register configures the drive strength of each port M output pin as either full or reduced. If the port is used as input this bit is ignored.

RDRM[7:0] — Reduced Drive Port M

1 = Associated pin drives at about 1/3 of the full drive strength.

0 = Full drive strength at output.

Port M Pull Device Enable Register (PERM)

Address Offset: \$0014

	Bit 7	6	5	4	3	2	1	Bit 0
Read:	PERM7	PERM6	PERM5	PERM4	PERM3	PERM2	PERM1	PERM0
Write:								
Reset:	0	0	0	0	0	0	0	0

 = Reserved or unimplemented

Read: Anytime.

Write: Anytime.

This register configures whether a pull-up or a pull-down device is activated, if the port is used as input or wired-or output. This bit has no effect if the port is used as push-pull output. Out of reset no pull device is enabled.

Port Integration Module

PERM[7:0] — Pull Device Enable Port M

1 = Either a pull-up or pull-down device is enabled.

0 = Pull-up or pull-down device is disabled.

**Port M Polarity
Select Register
(PPSM)**

Address Offset: \$0015

	Bit 7	6	5	4	3	2	1	Bit 0
Read:	PPSM7	PPSM6	PPSM5	PPSM4	PPSM3	PPSM2	PPSM1	PPSM0
Write:								
Reset:	0	0	0	0	0	0	0	0

 = Reserved or unimplemented

Read: Anytime.

Write: Anytime.

This register selects whether a pull-down or a pull-up device is connected to the pin. If CAN is active a pull-up device can be activated on the RxCAN[3:0] inputs, but not a pull-down. If BDLC is active a pull-down device can be activated on the RxBDLC pin but not a pull-up.

PPSM[7:0] — Pull Select Port M

1 = A pull-down device is connected to the associated port M pin, if enabled by the associated bit in register PERM and if the port is used as a general purpose or BDLC input but not as RxCAN.

0 = A pull-up device is connected to the associated port M pin, if enabled by the associated bit in register PERM and if the port is used as general purpose or RxCAN input but not as BDLC.

**Port M Wired-Or
Mode Register
(WOMM)**

Address Offset: \$0016

	Bit 7	6	5	4	3	2	1	Bit 0
Read:	WOMM7	WOMM6	WOMM5	WOMM4	WOMM3	WOMM2	WOMM1	WOMM0
Write:								
Reset:	0	0	0	0	0	0	0	0

 = Reserved or unimplemented

Read: Anytime.

Write: Anytime.

This register configures the output pins as wired-or. If enabled the output is driven active low only (open-drain). A logic level of '1' is not driven. It applies also to the CAN and BDLC outputs and allows a multipoint connection of several serial modules. This bit has no influence on pins used as inputs.

WOMM[7:0] — Wired-Or Mode Port M

1 = Output buffers operate as open-drain outputs.

0 = Output buffers operate as push-pull outputs.

**Port P I/O Register
(PTP)**

Address Offset: \$0018

	Bit 7	6	5	4	3	2	1	Bit 0
Read:	PTP7	PTP6	PTP5	PTP4	PTP3	PTP2	PTP1	PTP0
Write:								
PWM:	PWM7	PWM6	PWM5	PWM4	PWM3	PWM2	PWM1	PWM0
SPI:	SCK2	SS2	MOSI2	MISO2	SS1	SCK1	MOSI1	MISO1
Reset:	0	0	0	0	0	0	0	0

 = Reserved or unimplemented

Read: Anytime.

Write: Anytime.

If the data direction bits of the associated I/O pins are set to 1, a read returns the value of the port register, otherwise the value at the pins is

read.

The PWM function takes precedence over the general purpose I/O function if the associated PWM channel is enabled. While channels 6–0 are output only if the respective channel is enabled, channel 7 can be PWM output or input if the shutdown feature is enabled. *See Chapter PWM.*

The SPI function takes precedence over the general purpose I/O function associated with if enabled. *See Chapter SPI.*

If both PWM and SPI are enabled the PWM functionality takes precedence.

Port P Input Register (PTIP)

Address Offset: \$0019

	Bit 7	6	5	4	3	2	1	Bit 0
Read:	PTIP7	PTIP6	PTIP5	PTIP4	PTIP3	PTIP2	PTIP1	PTIP0
Write:								
Reset:	-	-	-	-	-	-	-	-

 = Reserved or unimplemented

Read: Anytime.

Write: Never; writes to this register have no effect.

This register always reads back the status of the associated pins. This can be also used to detect overload or short circuit conditions on output pins.

**Port P Data
Direction Register
(DDRP)**

Address Offset: \$001A

	Bit 7	6	5	4	3	2	1	Bit 0
Read:	DDRP7	DDRP6	DDRP5	DDRP4	DDRP3	DDRP2	DDRP1	DDRP0
Write:								
Reset:	0	0	0	0	0	0	0	0

 = Reserved or unimplemented

Read: Anytime.

Write: Anytime.

This register configures each port P pin as either input or output. If the associated PWM channel or SPI module is enabled this register has no effect on the pins.

The PWM forces the I/O state to be an output for each port line associated with an enabled PWM7–0 channel. Channel 7 can force the pin to input if the shutdown feature is enabled.

If a SPI module is enabled, the SPI determines the pin direction. *For details see SPI specification.*

The DDRM bits revert to controlling the I/O direction of a pin when the associated PWM channel is disabled.

DDRP[7:0] — Data Direction Port P

1 = Associated pin is configured as output.

0 = Associated pin is configured as input.

Due to internal synchronization circuits, it can take up to 2 bus cycles until the correct value is read on PTP or PTIP registers, when changing the DDRP register.

Port Integration Module

Port P Reduced Drive Register (RDRP)

Address Offset: \$001B

	Bit 7	6	5	4	3	2	1	Bit 0
Read:	RDRP7	RDRP6	RDRP5	RDRP4	RDRP3	RDRP2	RDRP1	RDRP0
Write:								
Reset:	0	0	0	0	0	0	0	0

= Reserved or unimplemented

Read: Anytime.

Write: Anytime.

This register configures the drive strength of each port P output pin as either full or reduced. If the port is used as input this bit is ignored.

RDRP[7:0] — Reduced Drive Port P

1 = Associated pin drives at about 1/3 of the full drive strength.

0 = Full drive strength at output.

Port P Pull Device Enable Register (PERP)

Address Offset: \$001C

	Bit 7	6	5	4	3	2	1	Bit 0
Read:	PERP7	PERP6	PERP5	PERP4	PERP3	PERP2	PERP1	PERP0
Write:								
Reset:	0	0	0	0	0	0	0	0

= Reserved or unimplemented

Read: Anytime.

Write: Anytime.

This register configures whether a pull-up or a pull-down device is activated, if the port is used as input. This bit has no effect if the port is used as output. Out of reset no pull device is enabled.

PERP[7:0] — Pull Device Enable Port P

1 = Either a pull-up or pull-down device is enabled.

0 = Pull-up or pull-down device is disabled.

**Port P Polarity
Select Register
(PPSP)**

Address Offset: \$001D

	Bit 7	6	5	4	3	2	1	Bit 0
Read:	PPSP7	PPSP6	PPSP5	PPSP4	PPSP3	PPSP2	PPSP1	PPSP0
Write:								
Reset:	0	0	0	0	0	0	0	0

 = Reserved or unimplemented

Read: Anytime.

Write: Anytime.

This register serves a dual purpose by selecting the polarity of the active interrupt edge as well as selecting a pull-up or pull-down device if enabled.

PPSP[7:0] — Polarity Select Port P

1 = Rising edge on the associated port P pin sets the associated flag bit in the PIFP register.

A pull-down device is connected to the associated port P pin, if enabled by the associated bit in register PERP and if the port is used as input.

0 = Falling edge on the associated port P pin sets the associated flag bit in the PIFP register.

A pull-up device is connected to the associated port P pin, if enabled by the associated bit in register PERP and if the port is used as input.

Port Integration Module

Port P Interrupt Enable Register (PIEP)

Address Offset: \$001E

	Bit 7	6	5	4	3	2	1	Bit 0
Read:	PIEP7	PIEP6	PIEP5	PIEP4	PIEP3	PIEP2	PIEP1	PIEP0
Write:								
Reset:	0	0	0	0	0	0	0	0

= Reserved or unimplemented

Read: Anytime.

Write: Anytime.

This register disables or enables on a per pin basis the edge sensitive external interrupt associated with port P.

PIEP[7:0] — Interrupt Enable Port P

1 = Interrupt is enabled.

0 = Interrupt is disabled (interrupt flag masked).

Port P Interrupt Flag Register (PIFP)

Address Offset: \$001F

	Bit 7	6	5	4	3	2	1	Bit 0
Read:	PIFP7	PIFP6	PIFP5	PIFP4	PIFP3	PIFP2	PIFP1	PIFP0
Write:								
Reset:	0	0	0	0	0	0	0	0

= Reserved or unimplemented

Read: Anytime.

Write: Anytime.

Each flag is set by an active edge on the associated input pin. This could be a rising or a falling edge based on the state of the PPSP register. To clear this flag, write '1' to the corresponding bit in the PIFP register.

Writing a '0' has no effect.

PIFP[7:0] — Interrupt Flags Port P

1 = Active edge on the associated bit has occurred (an interrupt will occur if the associated enable bit is set).
Writing a '1' clears the associated flag.

Writing a '1' clears the associated flag.

0 = No active edge pending.

Writing a '0' has no effect.

Port H I/O Register (PTH)

Address Offset: \$0020

	Bit 7	6	5	4	3	2	1	Bit 0
Read:	PTH7	PTH6	PTH5	PTH4	PTH3	PTH2	PTH1	PTH0
Write:								
Reset:	0	0	0	0	0	0	0	0

= Reserved or unimplemented

Read: Anytime.

Write: Anytime.

If the data direction bits of the associated I/O pins are set to 1, a read returns the value of the port register, otherwise the value at the pins is read.

Port H Input Register (PTIH)

Address Offset: \$0021

	Bit 7	6	5	4	3	2	1	Bit 0
Read:	PTIH7	PTIH6	PTIH5	PTIH4	PTIH3	PTIH2	PTIH1	PTIH0
Write:								
Reset:	-	-	-	-	-	-	-	-

= Reserved or unimplemented

Read: Anytime.

Write: Never; writes to this register have no effect.

This register always reads back the status of the associated pins. This can also be used to detect overload or short circuit conditions on output pins.

Port Integration Module

Port H Data Direction Register (DDRH)

Address Offset: \$0022

	Bit 7	6	5	4	3	2	1	Bit 0
Read:	DDRH7	DDRH6	DDRH5	DDRH4	DDRH3	DDRH2	DDRH1	DDRH0
Write:								
Reset:	0	0	0	0	0	0	0	0

= Reserved or unimplemented

Read: Anytime.

Write: Anytime.

This register configures each port H pin as either input or output.

DDRH[7:0] — Data Direction Port H

1 = Associated pin is configured as output.

0 = Associated pin is configured as input.

Due to internal synchronization circuits, it can take up to 2 bus cycles until the correct value is read on PTH or PTIH registers, when changing the DDRH register.

Port H Reduced Drive Register (RDRH)

Address Offset: \$0023

	Bit 7	6	5	4	3	2	1	Bit 0
Read:	RDRH7	RDRH6	RDRH5	RDRH4	RDRH3	RDRH2	RDRH1	RDRH0
Write:								
Reset:	0	0	0	0	0	0	0	0

= Reserved or unimplemented

Read: Anytime.

Write: Anytime.

This register configures the drive strength of each port H output pin as either full or reduced. If the port is used as input this bit is ignored.

RDRH[7:0] — Reduced Drive Port H

1 = Associated pin drives at about 1/3 of the full drive strength.

0 = Full drive strength at output.

**Port H Pull Device
Enable Register
(PERH)**

Address Offset: \$0024

	Bit 7	6	5	4	3	2	1	Bit 0
Read:	PERH7	PERH6	PERH5	PERH4	PERH3	PERH2	PERH1	PERH0
Write:								
Reset:	0	0	0	0	0	0	0	0

= Reserved or unimplemented

Read: Anytime.

Write: Anytime.

This register configures whether a pull-up or a pull-down device is activated, if the port is used as input. This bit has no effect if the port is used as output. Out of reset no pull device is enabled.

PERH[7:0] — Pull Device Enable Port H

1 = Either a pull-up or pull-down device is enabled.

0 = Pull-up or pull-down device is disabled.

**Port H Polarity
Select Register
(PPSH)**

Address Offset: \$0025

	Bit 7	6	5	4	3	2	1	Bit 0
Read:	PPSH7	PPSH6	PPSH5	PPSH4	PPSH3	PPSH2	PPSH1	PPSH0
Write:								
Reset:	0	0	0	0	0	0	0	0

= Reserved or unimplemented

Read: Anytime.

Write: Anytime.

This register serves a dual purpose by selecting the polarity of the active interrupt edge as well as selecting a pull-up or pull-down device if enabled.

PPSH[7:0] — Polarity Select Port H

1 = Rising edge on the associated port H pin sets the associated flag bit in the PIFH register.

A pull-down device is connected to the associated port H pin, if enabled by the associated bit in register PERH and if the port is used as input.

0 = Falling edge on the associated port H pin sets the associated flag bit in the PIFH register.

A pull-up device is connected to the associated port H pin, if enabled by the associated bit in register PERH and if the port is used as input.

Port H Interrupt Enable Register (PIEH)

Address Offset: \$0026

	Bit 7	6	5	4	3	2	1	Bit 0
Read:	PIEH7	PIEH6	PIEH5	PIEH4	PIEH3	PIEH2	PIEH1	PIEH0
Write:								
Reset:	0	0	0	0	0	0	0	0

 = Reserved or unimplemented

Read: Anytime.

Write: Anytime.

This register disables or enables on a per pin basis the edge sensitive external interrupt associated with port H.

PIEH[7:0] — Interrupt Enable Port H

1 = Interrupt is enabled.

0 = Interrupt is disabled (interrupt flag masked).

**Port H Interrupt
Flag Register
(PIFH)**

Address Offset: \$0027

	Bit 7	6	5	4	3	2	1	Bit 0
Read:	PIFH7	PIFH6	PIFH5	PIFH4	PIFH3	PIFH2	PIFH1	PIFH0
Write:								
Reset:	0	0	0	0	0	0	0	0

= Reserved or unimplemented

Read: Anytime.
Write: Anytime.

Each flag is set by an active edge on the associated input pin. This could be a rising or a falling edge based on the state of the PPSH register. To clear this flag, write '1' to the corresponding bit in the PIFH register. Writing a '0' has no effect.

PIFH[7:0] — Interrupt Flags Port H

- 1 = Active edge on the associated bit has occurred (an interrupt will occur if the associated enable bit is set).
Writing a '1' clears the associated flag.
- 0 = No active edge pending.
Writing a '0' has no effect.

**Port J I/O
Register (PTJ)**

Address Offset: \$0028

	Bit 7	6	5	4	3	2	1	Bit 0
Read:	PTJ7	PTJ6	0	0	0	0	PTJ1	PTJ0
Write:								
CAN:	TxCAN4	RxCAN4						
IIC:	SCL	SDA						
Reset:	0	0	0	0	0	0	0	0

= Reserved or unimplemented

Read: Anytime.
Write: Anytime.

Port Integration Module

If the data direction bits of the associated I/O pins are set to 1, a read returns the value of the port register, otherwise the value at the pins is read.

The CAN function (TxCAN and RxCAN) takes precedence over the general purpose I/O function if the associated CAN module is enabled. *See Chapter CAN.*

The IIC function takes precedence over the general purpose I/O function associated with if enabled.

If both CAN4 and IIC are enabled the CAN functionality takes precedence. *See Chapter IIC.*

If the IIC module is enabled the SDA and SCL outputs are configured as open-drain outputs.

Port J Input Register (PTIJ)

Address Offset: \$0029

	Bit 7	6	5	4	3	2	1	Bit 0
Read:	PTIJ7	PTIJ6	0	0	0	0	PTIJ1	PTIJ0
Write:								
Reset:	-	-	0	0	0	0	-	-

 = Reserved or unimplemented

Read: Anytime.

Write: Never; writes to this register have no effect.

This register always reads back the status of the associated pins. This can be used to detect overload or short circuit conditions on output pins.

**Port J Data
Direction Register
(DDRJ)**

Address Offset: \$002A

	Bit 7	6	5	4	3	2	1	Bit 0
Read:	DDRJ7	DDRJ6	0	0	0	0	DDRJ1	DDRJ0
Write:								
Reset:	0	0	-f	-f	-f	-f	0	0

= Reserved or unimplemented

Read: Anytime.

Write: Anytime.

This register configures each port J pin as either input or output. The CAN forces the I/O state to be an output on PJ7 (TxCAN4) and an input on pin PJ6 (RxCAN4). The IIC forces the I/O state to be an output or input dependent on the state of the IIC bus if enabled. In these cases the data direction bits will not change. The DDRJ bits revert to controlling the I/O direction of a pin when the associated timer output compare is disabled.

DDRJ[7:6][1:0] — Data Direction Port J

1 = Associated pin is configured as output.

0 = Associated pin is configured as input.

Due to internal synchronization circuits, it can take up to 2 bus cycles until the correct value is read on PTJ or PTIJ registers, when changing the DDRJ register.

Port Integration Module

Port J Reduced Drive Register (RDRJ)

Address Offset: \$002B

	Bit 7	6	5	4	3	2	1	Bit 0
Read:	RDRJ7	RDRJ6	0	0	0	0	RDRJ1	RDRJ0
Write:								
Reset:	0	0	0	0	0	0	0	0

= Reserved or unimplemented

Read: Anytime.

Write: Anytime.

This register configures the drive strength of each port J output pin as either full or reduced. If the port is used as input this bit is ignored.

RDRJ[7:6][1:0] — Reduced Drive Port J

1 = Associated pin drives at about 1/3 of the full drive strength.

0 = Full drive strength at output.

Port J Pull Device Enable Register (PERJ)

Address Offset: \$002C

	Bit 7	6	5	4	3	2	1	Bit 0
Read:	PERJ7	PERJ6	0	0	0	0	PERJ1	PERJ0
Write:								
Reset:	1	1	0	0	0	0	1	1

= Reserved or unimplemented

Read: Anytime.

Write: Anytime.

This register configures whether a pull-up or a pull-down device is activated, if the port is used as input or as wired-or output. This bit has no effect if the port is used as push-pull output. Out of reset a pull-up device is enabled.

PERJ[7:6][1:0] — Pull Device Enable Port J

1 = Either a pull-up or pull-down device is enabled.

0 = Pull-up or pull-down device is disabled.

**Port J Polarity
Select Register
(PPSJ)**

Address Offset: \$002D

	Bit 7	6	5	4	3	2	1	Bit 0
Read:	PPSJ7	PPSJ6	0	0	0	0	PPSJ1	PPSJ0
Write:								
Reset:	0	0	0	0	0	0	0	0

= Reserved or unimplemented

Read: Anytime.

Write: Anytime.

This register serves a dual purpose by selecting the polarity of the active interrupt edge as well as selecting a pull-up or pull-down device if enabled.

PPSJ[7:6][1:0] — Polarity Select Port H

1 = Rising edge on the associated port J pin sets the associated flag bit in the PIFJ register.

A pull-down device is connected to the associated port J pin, if enabled by the associated bit in register PERJ and if the port is used as input.

0 = Falling edge on the associated port J pin sets the associated flag bit in the PIFJ register.

A pull-up device is connected to the associated port J pin, if enabled by the associated bit in register PERJ and if the port is used as general purpose input, general purpose output in wired-or configuration or as IIC port.

Port Integration Module

Port J Interrupt Enable Register (PIEJ)

Address Offset: \$002E

	Bit 7	6	5	4	3	2	1	Bit 0
Read:	PIEJ7	PIEJ6	0	0	0	0	PIEJ1	PIEJ0
Write:								
Reset:	0	0	0	0	0	0	0	0

= Reserved or unimplemented

Read: Anytime.

Write: Anytime.

This register disables or enables on a per pin basis the edge sensitive external interrupt associated with port J.

PIEJ[7:6][1:0] — Interrupt Enable Port J

1 = Interrupt is enabled.

0 = Interrupt is disabled (interrupt flag masked).

Port J Interrupt Flag Register (PIFJ)

Address Offset: \$002F

	Bit 7	6	5	4	3	2	1	Bit 0
Read:	PIFJ7	PIFJ6	0	0	0	0	PIFJ1	PIFJ0
Write:								
Reset:	0	0	0	0	0	0	0	0

= Reserved or unimplemented

Read: Anytime.

Write: Anytime.

Each flag is set by an active edge on the associated input pin. This could be a rising or a falling edge based on the state of the PPSJ register. To clear this flag, write '1' to the corresponding bit in the PIFJ register.

Writing a '0' has no effect.

PIFH[7:6][1:0] — Interrupt Flags Port J

1 = Active edge on the associated bit has occurred (an interrupt will occur if the associated enable bit is set).
Writing a '1' clears the associated flag.

0 = No active edge pending.
Writing a '0' has no effect.

Reset Initialization

All registers including the data registers get set/reset asynchronously.

Functional Description

General

Each pin can act as general purpose I/O. In addition the pin can act as an output from a peripheral module or an input to a peripheral module. A set of configuration registers is common to all ports. All registers can be written at any time, however a specific configuration might not become active.

Example:

Selecting a pull-up resistor. This resistor does not become active while the port is used as a push-pull output.

I/O register

This register holds the value driven out to the pin if the port is used as a general purpose I/O. Writing to this register has only an effect on the pin if the port is used as general purpose output. When reading this address, the value of the pins is returned if the data direction register bits are set to 0. If the data direction register bits are set to 1, the contents of the I/O register is returned. This is independent of any other configuration.

Input register

This is a read-only register and always returns the value of the pin.

Port Integration Module

Data direction register

This register defines whether the pin is used as an input or an output. If a peripheral module controls the pin the contents of the data direction register is ignored.

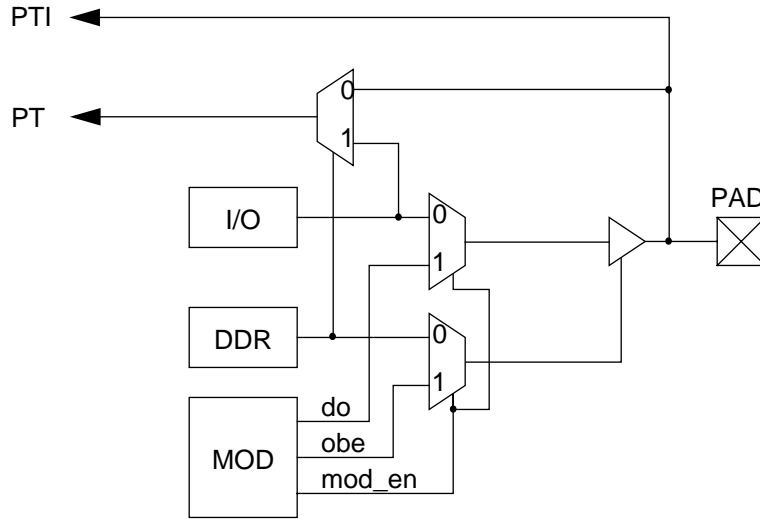

Figure 26 Illustration of I/O pin functionality

Reduced drive register

If the port is used as an output the register allows the configuration of the drive strength.

Pull device enable register

This register turns on a pull-up or pull-down device. It becomes only active if the pin is used as an input or as a wired-or output.

Polarity select register

This register selects either a pull-up or pull-down device if enabled. It becomes only active if the pin is used as an input. A pull-up device can be activated if the pin is used as a wired-or output.

Port T

This port is associated with the Enhanced Capture Timer module. In all modes, port T pins PT[7:0] can be used for either general-purpose I/O, or with the channels of the Enhanced Capture Timer. During reset, port T pins are configured as high-impedance inputs.

Port S This port is associated with the serial SCI and SPI modules. In all modes, port S pins PS[7:0] can be used either for general-purpose I/O, or with the SCI and SPI subsystems. During reset, port S pins are configured as inputs with pull-up.

Port M This port is associated with the J1850 and 4 CAN modules. In all modes, port M pins PM[7:0] can be used for either general purpose I/O, or with the CAN and J1850 subsystems. Pins PM0 and PM1 are shared between the CAN0 and the BDLC (J1850) module. If CAN0 is enabled the pins become CAN transmit and receive pins. If BLDC is enabled and CAN0 is disabled, pins become active BDLC transmit and receive pins. During reset, port M pins are configured as high-impedance inputs.

Port P This port is associated with the PWM and 2 SPI modules. In all modes, port P pins PP[7:0] can be used for either general purpose I/O, or with the PWM and SPI subsystems. The pins are shared between the PWM channels and the SPI1 and SPI2 modules. If the PWM is enabled the pins become PWM output channels with the exception of pin 7 which can be PWM input or output. If SPI1 or SPI2 are enabled and PWM is disabled, the respective pin configuration is determined by several status bits in the SPI modules. During reset, port P pins are configured as high-impedance inputs.

Port P offers 8 I/O pins with edge triggered interrupt capability in wired-or fashion. The interrupt enable as well as the sensitivity to rising or falling edges can be individually configured on per pin basis. All 8 bits/pins share the same interrupt vector. Interrupts can be used with the pins configured as inputs or outputs.

An interrupt is generated when a bit in the port interrupt flag register and its corresponding port interrupt enable bit are both set.

This external interrupt feature is capable to wake up the CPU when it is in STOP or WAIT mode.

A digital filter on each pin prevents pulses shorter than a specified time from generating an interrupt (see [Pulse Detection Criteria](#)). Four

consecutive samples have to be either low or high in order to detect a valid low or high input.

The filters are continuously clocked by the bus clock in RUN and WAIT mode. In STOP mode the clock is generated by a single RC oscillator in the Port Integration Module. To maximize current saving the RC oscillator runs only if the following condition is true on any pin:

- Active level at the input as defined by the port polarity select register (PPS)
- and port interrupt enabled (PIE=1)
- and port interrupt flag not set (PIF=0).

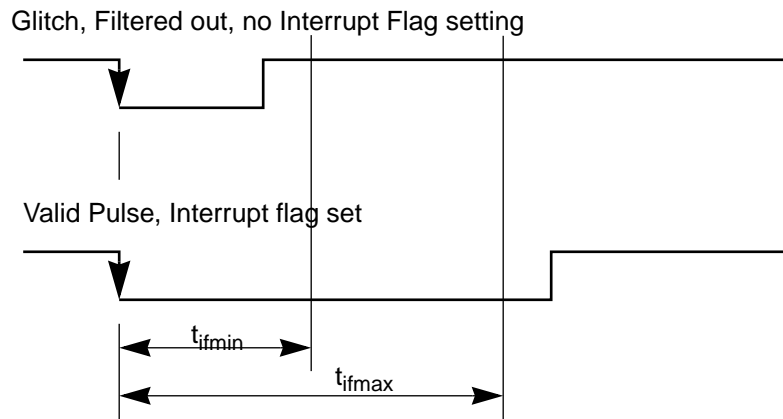

Figure 27 Interrupt Glitch Filter on Port P, H and J

Table 43 Pulse Detection Criteria

Pulse	Mode			
	STOP		STOP ⁽¹⁾	
	t_{if}	Unit	t_{if}	Unit
Ignored	$t_{pulse} \leq 3$	bus clocks	$t_{pulse} \leq 3.2$	μs
Uncertain	$3 < t_{pulse} < 4$	bus clocks	$3.2 < t_{pulse} < 10$	μs
Valid	$t_{pulse} \geq 4$	bus clocks	$t_{pulse} \geq 10$	μs

1. These values include the spread of the oscillator frequency over temperature, voltage and process.

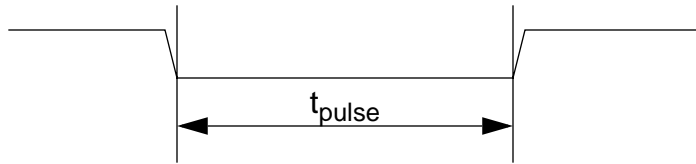

Figure 28 Pulse Illustration

Port H Port H offers 8 I/O ports with the same interrupt features as port P.

Port J This port is associated with the fifth CAN and the IIC module. In all modes, port J pins PJ[7:6] and PJ[1:0] can be used for either general purpose I/O, or with the CAN and IIC subsystems. Pins PJ6 and PJ7 are shared between the CAN4 and the IIC module. If CAN4 is enabled the pins become CAN transmit and receive pins. If IIC is enabled and CAN4 is disabled, the pins become IIC open-drain output pins. During reset, port J pins are configured as inputs with pull-up.

Port J offers 4 I/O ports with the same interrupt features as port P.

Low Power Options

Run Mode No low power options exist for this module in run mode.

Wait Mode No low power options exist for this module in wait mode.

Stop Mode All clocks are stopped. There are however asynchronous paths to generate interrupts from STOP on port P, H and J.

Interrupt Operation

Port P, H and J generate a separate edge sensitive interrupt if enabled.

Interrupt Sources

Table 44 Port Integration Module Interrupt Sources

Interrupt Source	Interrupt Flag	Local Enable	Global (CCR) Mask
Port P	PIFP[7:0]	PIEP[7:0]	I Bit
Port H	PIFH[7:0]	PIEH[7:0]	I Bit
Port J	PIFJ[7:6][1:0]	PIFJ[7:6][1:0]	I Bit

NOTE: *Vector addresses and their relative interrupt priority are determined at the MCU level.*

Recovery from STOP

This module can generate wake-up interrupts from STOP on port P, H and J. For other sources of external interrupts refer to the respective module specification.

Clocks and Reset Generator (CRG)

Contents

Overview	257
Features	258
Block Diagram	259
Register Map	260
Functional Description	261
Register Descriptions	279
External Pin Descriptions	292
Reset Initialization	294
Interrupt Operation	294
Low Power Options	296

Overview

This specification describes the function of the Clocks and Reset Generator (CRG) and Oscillator (OSC) modules.

Features

The main features of this block are:

- Crystal (or ceramic resonator) oscillator (OSC)
 - Crystal Monitor (CM)
 - Startup counter
- Phase Locked Loop (PLL) frequency multiplier
 - Reference divider
 - Automatic Bandwidth control mode for low-jitter operation
 - Automatic Frequency lock detector
 - CPU interrupt on Entry or Exit from Locked condition
 - Self Clock mode in absence of reference clock
- System Clock Generator (CGEN)
 - External Clock mode
 - System clock switch
 - System clocks off during WAIT mode
- System Reset Generator (RGEN)
 - Computer Operating Properly (COP) Watchdog Timer with time-out clear window.
 - Loss of crystal clock reset
 - External pin reset
- Real-Time Interrupt (RTI)

Block Diagram

The block diagram below shows a high level view of the CRG and OSC modules.

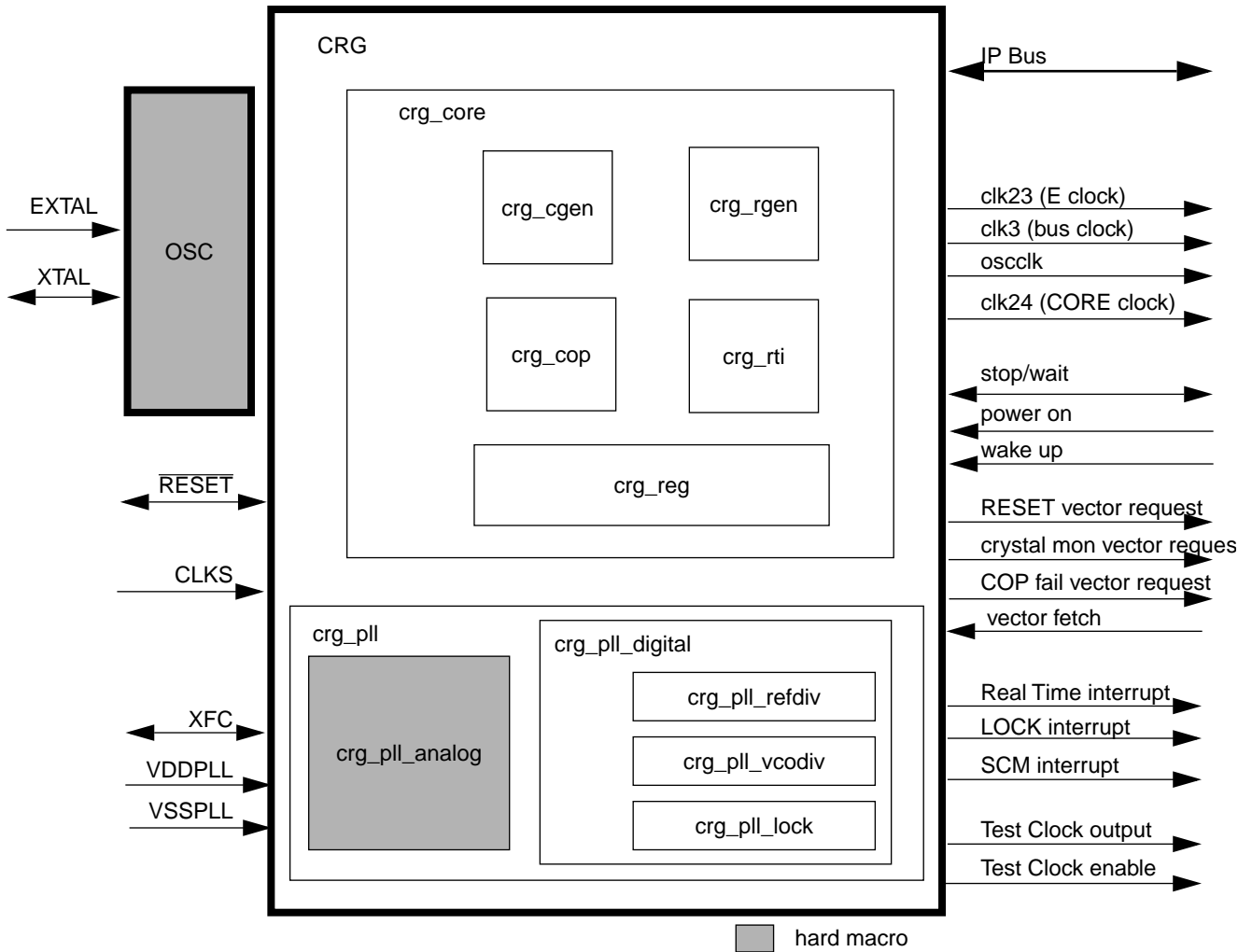

Figure 29 Block diagram of CRG and OSC

Clocks and Reset Generator (CRG)
Register Map

The register map for the CRG appears below.

Reg Name		Bit 7	6	5	4	3	2	1	Bit 0
SYNR	Read:	0	0	SYN5	SYN4	SYN3	SYN2	SYN1	SYN0
	Write:								
REFDV	Read:	0	0	0	0	REFDV3	REFDV2	REFDV1	REFDV0
	Write:								
CTFLG	Read:	TOUT7	TOUT6	TOUT5	TOUT4	TOUT3	TOUT2	TOUT1	TOUT0
	Write:								
CRGFLG	Read:	RTIF	PORF	0	LOCKIF	LOCK	TRACK	SCMIF	SCM
	Write:								
CRGINT	Read:	RTIE	0	0	LOCKIE	0	0	SCMIE	0
	Write:								
CLKSEL	Read:	PLLSEL	PSTP	SYSWAI	ROAWAI	PLLWAI	CWAI	RTIWAI	COPWAI
	Write:								
PLLCTL	Read:	CME	PLLON	AUTO	ACQ	0	0	0	SCME
	Write:								
RTICTL	Read:	0	RTR6	RTR5	RTR4	RTR3	RTR2	RTR1	RTR0
	Write:								
COPCTL	Read:	WCOP	0	0	0	0	CR2	CR1	CR0
	Write:								
FORBYP	Read:	RTIBYP	COPBYP	0	PLLBYP	SCBYP	0	FCM	0
	Write:								
CTCTL	Read:	TCTL7	TCTL6	TCTL5	TCTL4	TCTL3	TCTL2	TCTL1	TCTL0
	Write:								
ARMCOP	Read:	0	0	0	0	0	0	0	0
	Write:	Bit 7	Bit 6	Bit 5	Bit 4	Bit 3	Bit 2	Bit 1	Bit 0

= Reserved or unimplemented

Table 45 CRG Register Address Summary

Register	SYN	REFDV	CTFLG	CRGFLG	CRGINT	CLKSEL
Base Address	\$0000	\$0001	\$0002	\$0003	\$0004	\$0005
Register	PLLCTL	RTICTL	COPCTL	FORBYP	CTCTL	ARMCOP
Base Address	\$0006	\$0007	\$0008	\$0009	\$000A	\$000B

NOTE: *Register Address = Module Address + Base Address + Address Offset*

The Module Address is determined at the MCU level.

The Address Offset is determined by a switch in the i/o of the module. If the switch is set, the address offset is four bytes, and if it is clear there is no offset.

Functional Description

Oscillator (OSC)

The oscillator block has two external pins, EXTAL and XTAL. See [Register Descriptions](#). The oscillator input pin, EXTAL, is intended to be connected to either a crystal or an external clock source. The XTAL pin is an output signal that provides crystal circuit feedback and can be buffered to drive other devices with same voltage amplitude. It is also used as an input pin during test when the MCU has an external clock source.

A buffered EXTAL signal, OSCCLK, becomes the internal reference clock. The oscillator is enabled based on the PSTP bit, and the STOP condition. The oscillator is disabled when the part is in STOP mode except when Pseudo-Stop mode is enabled. See [Register Descriptions](#) for detailed bit descriptions.

To improve noise immunity, the OSC is powered by the VDDPLL and VSSPLL power supply pins.

Clocks and Reset Generator (CRG)

The crystal oscillator is equipped with a feedback system which does not waste current generating harmonics. Its configuration is “Colpitts oscillator with translated ground”. The transconductor used is driven by a current source under the control of a peak detector which will measure the amplitude of the AC signal appearing on EXTAL node in order to implement an Amplitude Limitation Control (ALC) loop. The ALC loop is in charge of reducing the quiescent current in the transconductor as a result of an increase in the peak-to-peak oscillation amplitude.

Crystal Monitor (CM)

The crystal monitor circuit is based on an internal resistor-capacitor (RC) time delay so that it can operate without any MCU clocks. If no clock edges are detected within this RC time delay, the crystal monitor indicates failure which asserts self clock mode or generates a system reset depending on the state of SCME bit. If the crystal monitor is disabled or the presence of clocks are detected no failure is indicated. The crystal monitor function is enabled/disabled by the CME control bit. See [Register Descriptions](#).

Startup counter

The Startup Counter is a 14-stage ripple free-running counter that counts system clock cycles to ensure proper oscillator start up recovery. It is initialized at power on, stop mode, and any failure indicated by the crystal monitor when SCME bit is cleared. See [Crystal loss, stop and startup](#) for more information.

Phase Locked Loop (PLL)

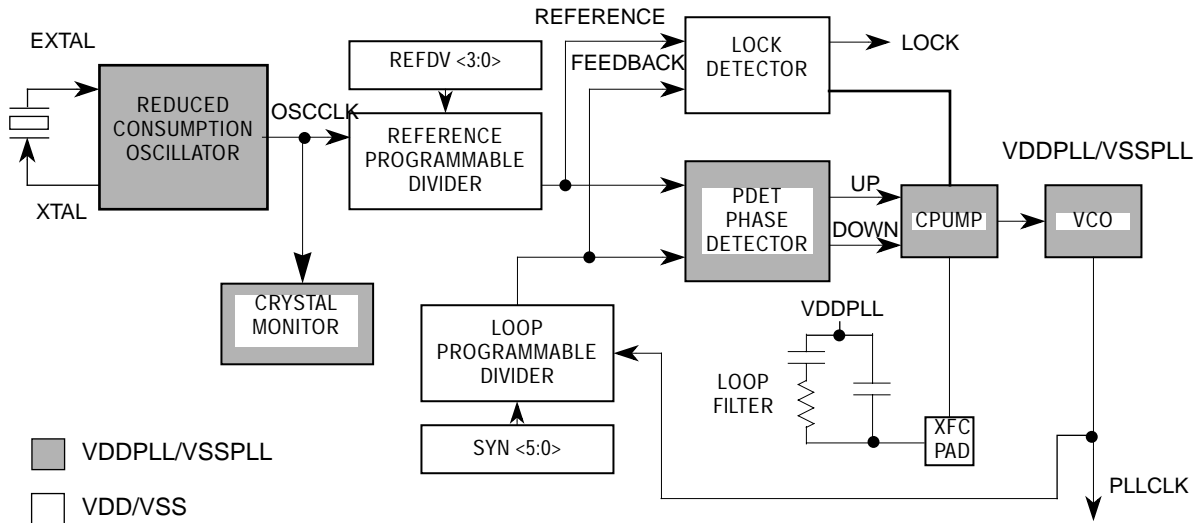

Figure 30 PLL Functional Diagram

The PLL is used to run the MCU from a different time base than the incoming crystal value. For increased flexibility, the crystal clock can be divided in a range of 1 to 16 to generate the reference frequency. This offers a finer multiplication granularity. The PLL can multiply this reference clock by a multiple of 2, 4, 6, ... 126,128 based on the SYN register.

$$PLLCLK = 2 \times OSCCLK \times [SYNR + 1] / [REFDV + 1]$$

NOTE: Although it is possible to set the two dividers to command a very high clock frequency, do not exceed the specified bus frequency limit for the MCU.

The PLL is a frequency generator that operates in either acquisition mode or tracking mode, depending on the difference between the output frequency and the target frequency. The PLL can change between acquisition and tracking modes either automatically or manually.

Clocks and Reset Generator (CRG)

The VCO has a minimum operating frequency, which corresponds to the self clock mode frequency.

NOTE: *Although it is possible to synthesize a PLLCLK frequency less than OSCCLK, some systems using a constant OSCCLK frequency base may not be able to operate.*

PLL operation

The OSCCLK input is fed through the reference programmable divider and is divided in a range of 1 to 16, [REFDV +1], to output the REFERENCE clock. The VCO output clock, PLLCLK, is fed back through the programmable loop divider and is divided in a range of 2 to 128 in increments of two, $2 \times [\text{SYNR} + 1]$, to output the FEEDBACK clock. See [Figure 30](#).

The phase detector then compares the FEEDBACK clock, with the REFERENCE clock. Correction pulses are generated based on the phase difference between the two signals. The loop filter then slightly alters the D.C. voltage on the external filter connected to XFC pad, based on the width and direction of the correction pulse. The filter can make fast or slow corrections depending on its mode, described in [Acquisition and tracking Modes](#) below. The values of the external filter network and the reference frequency determines the speed of the corrections and the stability of the PLL.

Acquisition and tracking Modes

The lock detector compares the frequencies of the FEEDBACK clock, and the REFERENCE clock. Therefore, the speed of the lock detector is directly proportional to the final reference frequency. The circuit determines the mode of the PLL and the lock condition based on this comparison.

The PLL filter is manually or automatically configured into one of two operating modes:

Acquisition mode — In acquisition mode, the filter can make large frequency corrections to the VCO. This mode is used at PLL start-up or when the PLL has suffered a severe noise hit and the VCO frequency is far off the desired frequency. When in acquisition mode, the TRACK status bit is cleared in the CRGFLG register.

Tracking mode — In tracking mode, the filter makes only small corrections to the frequency of the VCO. PLL jitter is much lower in tracking mode, but the response to noise is also slower. The PLL enters tracking mode when the VCO frequency is nearly correct and the TRACK bit is set in the CRGFLG register.

The PLL can change the bandwidth or operational mode of the loop filter manually or automatically.

In automatic bandwidth control mode (AUTO = 1), the lock detector automatically switches between acquisition and tracking modes. Automatic bandwidth control mode also is used to determine when the PLL clock, PLLCLK, is safe to use as the source for the system clock, SYSCLK. If PLL LOCK interrupt requests are enabled, the software can wait for an interrupt request and then check the LOCK bit. If CPU interrupts are disabled, software can poll the LOCK bit continuously (during PLL start-up, usually) or at periodic intervals. In either case, only when the LOCK bit is set, is the PLLCLK clock safe to use as the source for the system clock. If the PLL is selected as the source for the system clock and the LOCK bit is clear, the PLL has suffered a severe noise hit and the software must take appropriate action, depending on the application.

The following conditions apply when the PLL is in automatic bandwidth control mode (AUTO=1):

- The TRACK bit is a read-only indicator of the mode of the filter.
- The TRACK bit is set when the VCO frequency is within a certain tolerance, Δ_{trk} , and is clear when the VCO frequency is out of a certain tolerance, Δ_{unt} .
- The LOCK bit is a read-only indicator of the locked state of the PLL.
- The LOCK bit is set when the VCO frequency is within a certain tolerance, Δ_{Lock} , and is cleared when the VCO frequency is out of a certain tolerance, Δ_{unl} .
- CPU interrupts can occur if enabled (LOCKIE = 1) when the lock condition changes, toggling the LOCK bit.

Clocks and Reset Generator (CRG)

The PLL also can operate in manual mode (AUTO = 0). Manual mode is used by systems that do not require an indicator of the lock condition for proper operation. Such systems typically operate well below the maximum system frequency, f_{sys} , and require fast start-up. The following conditions apply when in manual mode:

- ACQ is a writable control bit that controls the mode of the filter. Before turning on the PLL in manual mode, the ACQ bit should be set to configure the filter in acquisition mode.
- Before entering tracking mode (ACQ = 0), software must wait a given time, t_{acq} , after turning on the PLL by setting PLLON in the PLL control register, or wait until TRACK bit gets set.
- Software must wait a given time, t_{al} , after entering tracking mode before selecting the PLLCLK as the SYSCLK clock source (PLLSEL = 1).

Self clock mode

The VCO has a minimum operating frequency, f_{VCOMIN} . If the crystal frequency is not available due to a failure or due to long crystal start-up time, the MCU system clock can be supplied by the VCO. This mode of operation is called Self-Clock mode. See [Crystal loss, stop and startup](#) for more information.

Crystal loss, stop and startup

The lack of external clocks can occur in three configurations, which are described below:

1. At Power-On Reset.
2. During normal clock operation.
3. In the STOP exit sequence.

Crystal startup at Power-On

Any reset sets the Crystal Monitor Enable bit, CME, the PLLON bit, and the self clock mode enable bit, SCME. Therefore, if the MCU is powered up without an external clock, self-clock mode is activated.

During a normal power up sequence without an external clock, after the POR pulse falling edge, the VCO supplies the self-clock mode frequency to the 14-stage Startup Counter as the output of the PLLSEL bit is forced

high. After the Startup Counter reaches the end of the count, 8192 self clock mode cycles, reset is released. At this time, if the crystal monitor indicates the presence of an external clock, self-clock mode is de-asserted and the MCU exits reset normally, using OSCCLK clock. In case the crystal start-up time is longer than the initial count of 8192 self clock mode cycles, or in the absence of an external clock, the MCU leaves the reset state in self-clock mode. Both SCM and SCMIF bits are set indicating the MCU is not operating at the desired frequency. Each time the Startup Counter reaches the end of the count, a check of the crystal monitor status is performed. When the presence of an external clock is detected, the SCM flag is cleared. This sets the self-clock interrupt flag and if enabled by the SCMIE bit, the self-clock mode interrupt is requested.

See [Figure 31](#).

Clocks and Reset Generator (CRG)

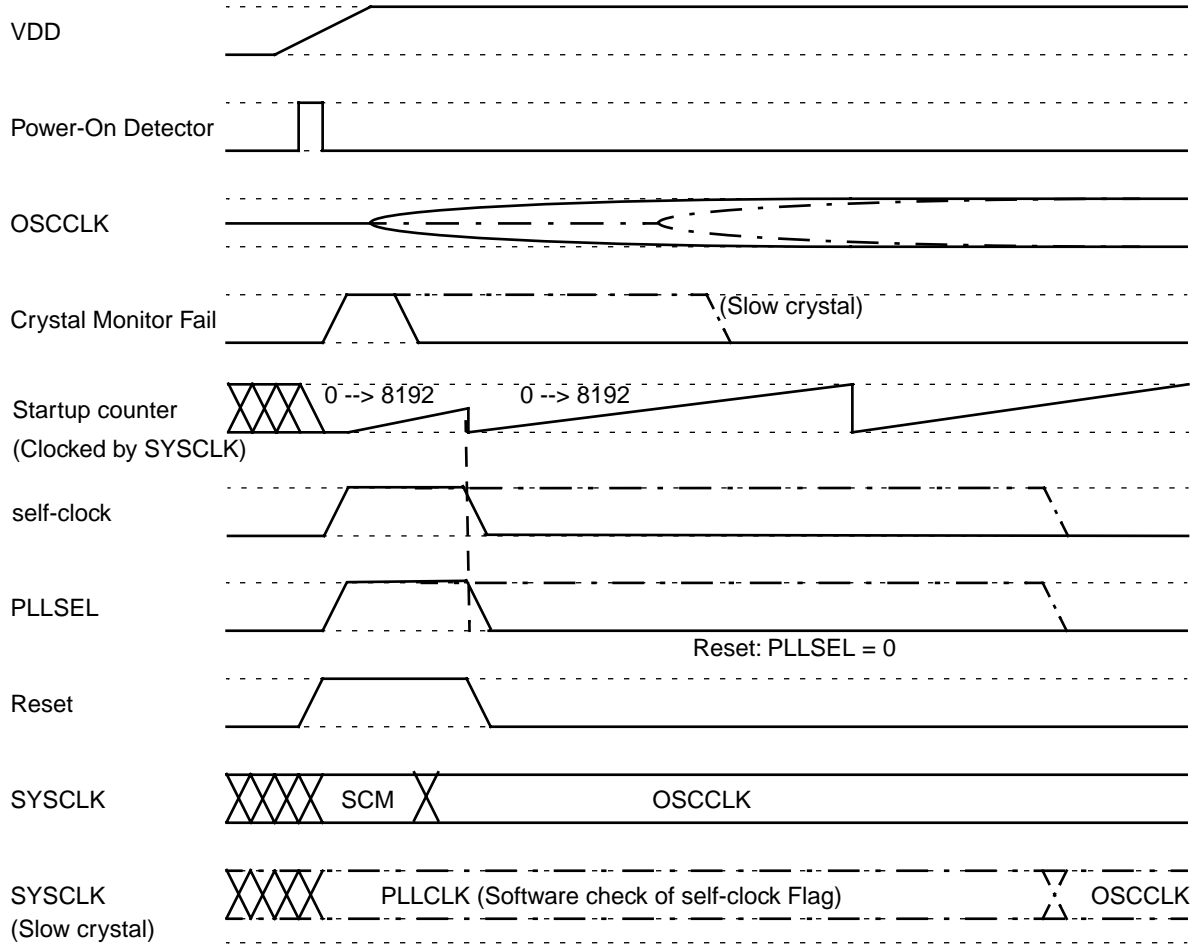

Figure 31 No Clock at Power-On

Crystal Clock Loss during Normal Operation

The self-clock mode enable bit, SCME, the crystal monitor enable bit, CME, and the PLLSEL bit determine how the MCU responds to an external crystal clock loss.

If the CME bit is cleared when a loss of crystal clock happens, the MCU goes static if PLLSEL is cleared, or it drifts to self clock mode if PLLSEL is set but the self clock mode status will not be indicated.

If the SCME bit is cleared, with CME set, and a loss of crystal clock is detected by the crystal monitor circuit, the MCU resets. The MCU remains static until crystal activity is detected. Then the Startup Counter

counts 8192 crystal clock cycles and at the end of the start up count the MCU completes its internal reset sequence.

If the SCME and CME bits are set, and a loss of crystal clock is detected by the crystal monitor circuit, the PLL VCO clock at its minimum frequency is provided as the system clock (self clock mode), allowing the MCU to continue operating. In self-clock mode, PLLON and PLLSEL outputs are forced high. The SCM flag in the CRGFLG register indicates that the MCU is running in self-clock mode. A change of this flag sets the self-clock interrupt flag and if enabled by the SCMIE bit, the self-clock mode interrupt is requested.

Each time the Startup Counter reaches the end of the count, a check of the crystal monitor status is performed. When the presence of an external clock is detected, the MCU leaves self-clock mode and the SCM flag is cleared. This also sets the self-clock interrupt flag. Upon leaving self-clock mode, PLLSEL is restored to its value before the crystal clock loss, and the system clock returns to its previous frequency. If AUTO and PLLSEL were set before the crystal clock loss, the system clock ramps-up and the PLL locks at the previously selected frequency. See [Figure 32](#).

NOTE: *There is a delay between the loss of crystal clock and its detection by the crystal monitor. If the MCU is clocked by OSCCLK and the PLL is not used there is a potential for runaway code by the CPU before self clock mode is activated. The best policy is to clear SCME when the MCU is clocked by OSCCLK to get a monitor reset. The COP watch dog should always be enabled in order to reset the MCU in case of a code runaway situation.*

Clocks and Reset Generator (CRG)

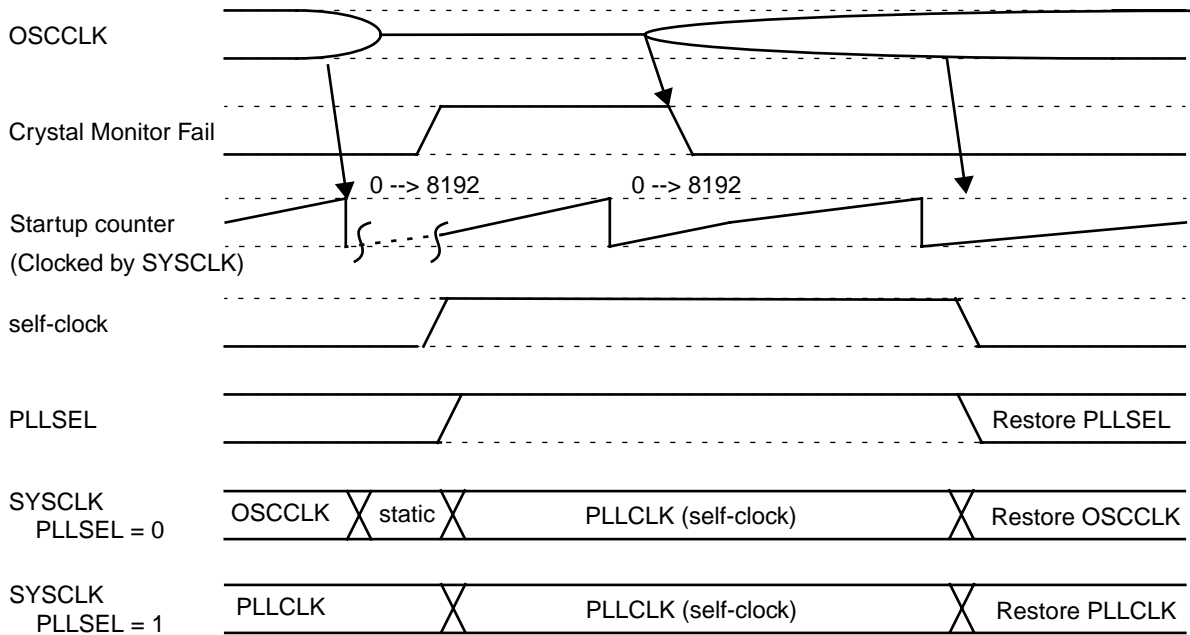

Figure 32 Crystal Clock Loss during Normal Operation

STOP mode

If CME bit is cleared, the MCU goes into STOP mode when a STOP instruction is executed. STOP mode can then be exited with an external asynchronous interrupt or an external reset. The clock generator remains static until crystal activity is detected. The MCU will continue activity after the Startup Counter completes 8192 OSCCLK cycles.

If CME bit is set and SCME bit is cleared, a crystal monitor failure is detected when a STOP instruction is executed and the MCU resets. The MCU remains in reset until the Startup counter completes counting 8192 OSCCLK cycles.

If CME and SCME bits are set, the MCU goes into STOP mode when a STOP instruction is executed. STOP mode can then be exited with an external asynchronous interrupt or an external reset.

Upon exiting STOP with an interrupt, the MCU goes into self-clock mode in the absence of a stable oscillator and the output of the PLLSEL bit is forced high. The MCU recovers from STOP in self-clock mode, with both SCM and SCMIF bits set, to indicate it is not operating at the desired frequency. The VCO supplies the self clock mode frequency to the

Startup Counter. When the presence of an external clock is detected, the SCM flag is cleared. This sets the self-clock interrupt flag and if enabled by the SCMIE bit, the self-clock mode interrupt is requested. Upon leaving self-clock mode, PLLSEL is restored to its value before the loss of crystal clock, and the system clock returns to its previous frequency. If AUTO and PLLSEL were set before the crystal clock loss, the system clock ramps-up and the PLL locks at the previously selected frequency. To prevent PLL operation when the external clock frequency comes back, the software should clear the PLLSEL bit while running in self-clock mode.

Upon exiting STOP with an external reset, the MCU remains in reset until the Startup counter reaches the end of the 8192 OSCCLK cycles.

See [Figure 33](#).

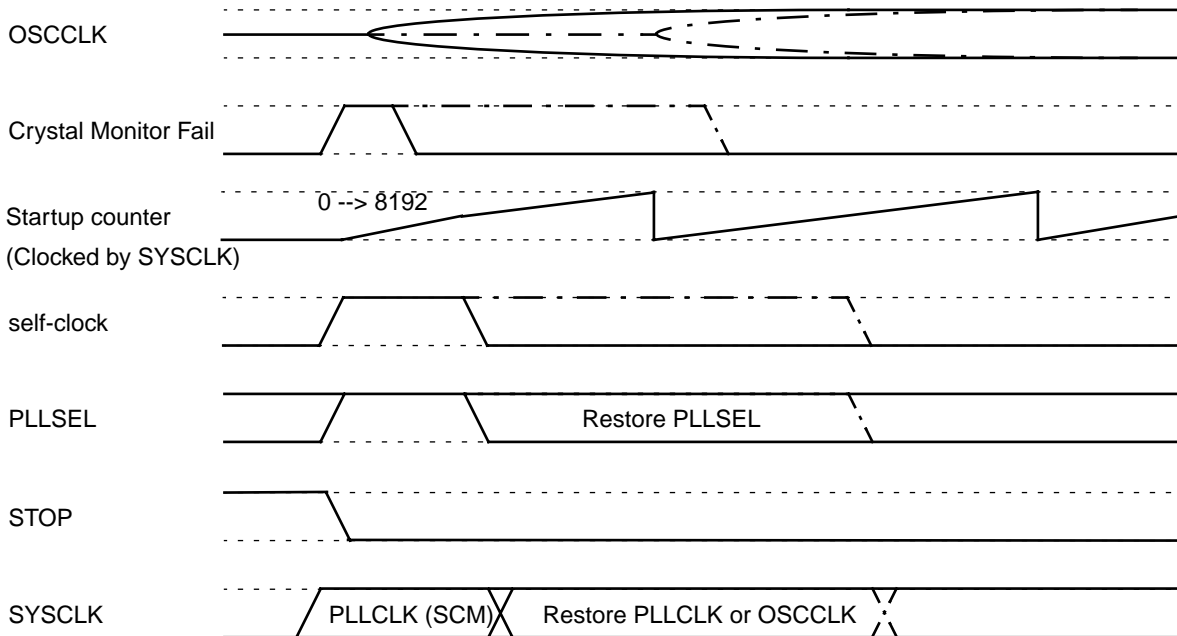

Figure 33 STOP Exit and Fast STOP Recovery

Clocks and Reset Generator (CRG)
Table 46 Outcome of oscillation absence conditions

Condition	Startup counter clock	Outcome
POR	Self clock	Part resets. Startup counter starts in self clock mode. Part switches to OSCCLK when crystal monitor indicates no failure and at the end of the startup counter.
CME=0; PLLSEL=0; SCME=x Crystal failure	None	Part goes static
CME=0; PLLSEL=1; SCME=x Crystal failure	None	Part drifts to self clock frequency but mode is not asserted.
CME=1; PLLSEL=x; SCME=0 Crystal failure	OSCCLK	Part resets. Clocks are not used until the end of the Startup counter, and then part comes out of reset.
CME=1; PLLSEL=x; SCME=1 Crystal failure	Self clock	Part goes into self clock mode.
CME=x; PLLSEL=0; SCME=0 STOP exit w/ async interrupt	OSCCLK	Clocks are not used until the end of the Startup counter.
CME=x; PLLSEL=1; SCME=0 STOP exit w/ async interrupt	PLLCLK	Clocks are not used until the end of the Startup counter.
CME=x; PLLSEL=x; SCME=1 STOP exit w/ async interrupt	Self clock	Part wakes up in self clock mode. Part returns to previous if crystal monitor indicates no failure at the end of the Startup counter.
CME=x; PLLSEL=x; SCME=0 RESET during STOP before monitor timeout	OSCCLK	Part resets. Clocks are not used until the end of the Startup counter.
CME=x; PLLSEL=x; SCME=1 RESET during STOP before monitor timeout	Self clock	Part resets. Clocks are not used until the end of the Startup counter.
CME=0; PLLSEL=x; SCME=0 RESET during STOP after monitor timeout	OSCCLK	Part resets. Clocks are not used until the end of the Startup counter.
CME=1; PLLSEL=x; SCME=0 RESET during STOP after monitor timeout	OSCCLK	Monitor reset occurs. Clocks are not used until the end of the Startup counter.
CME=x; PLLSEL=x; SCME=1 RESET during STOP after monitor timeout	Self clock	Part resets. Clocks are not used until the end of the Startup counter.

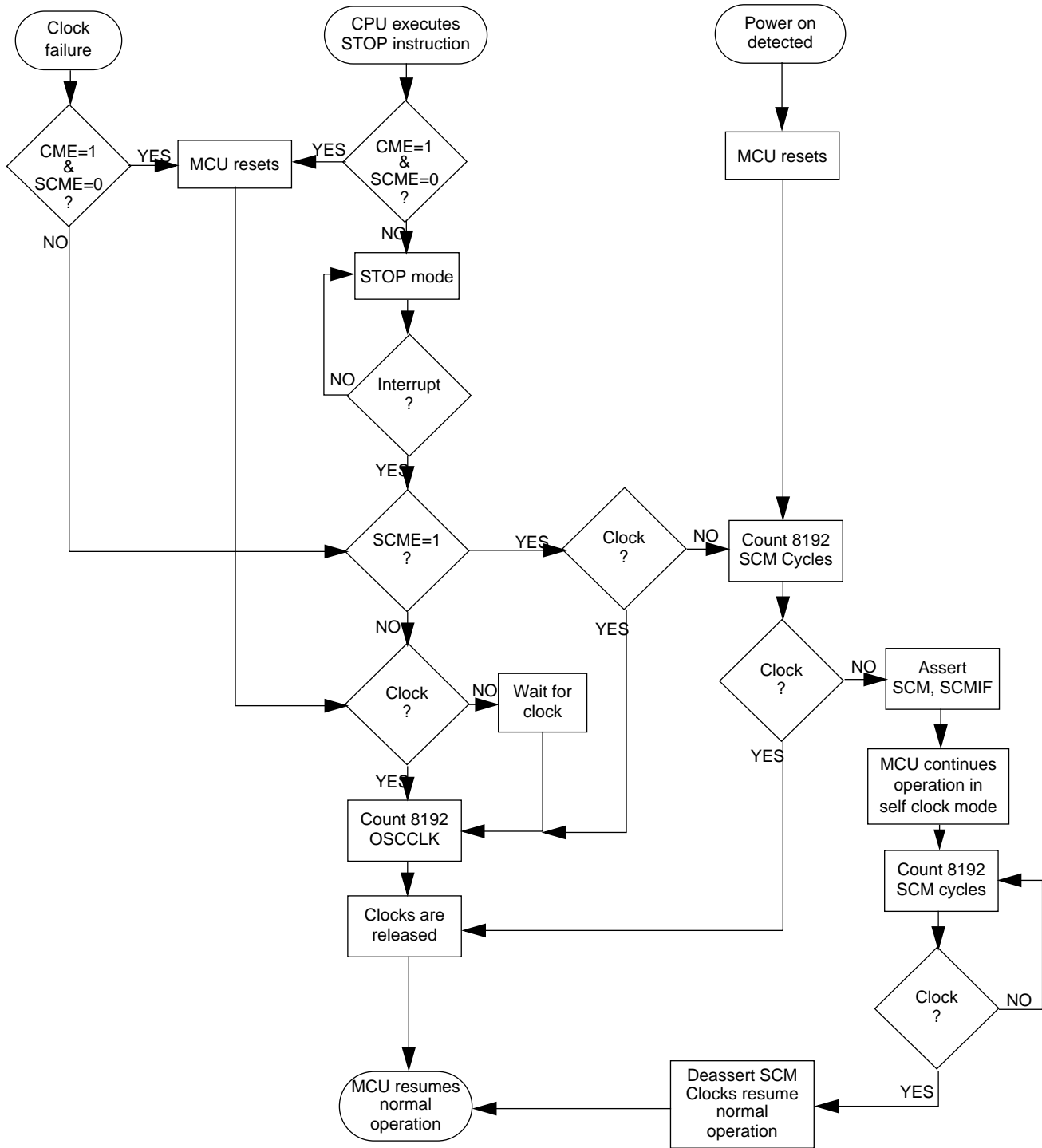

Figure 34 Crystal loss, stop and startup sequence

Clocks and Reset Generator (CRG)

**System Clocks
Generator**

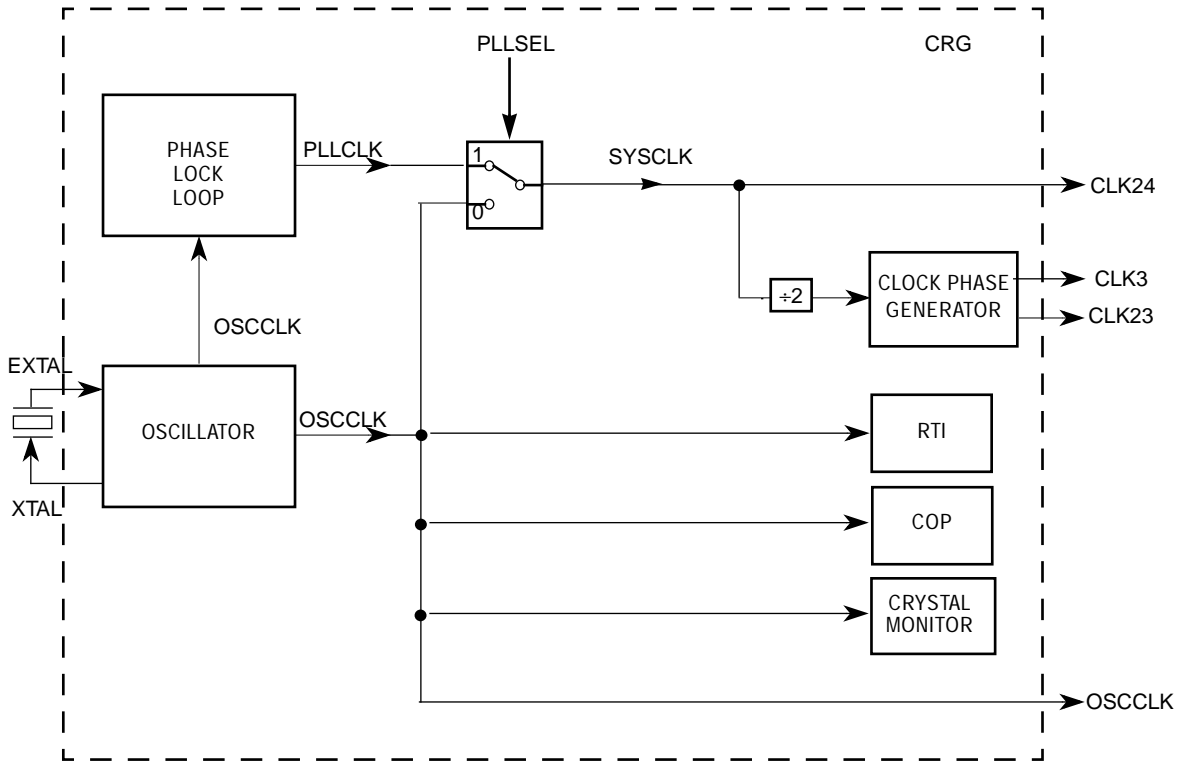

Figure 35 Clock Generator

The clock generator creates the system clocks used in the MCU. The peripheral and memory modules use CLK3. The CLK23 signal is used to generate the clock visible at the ECLK pin. The CLK24 signal is the clock for the STAR12 Core. [Figure 36](#) shows the ideal phase relationships of the system clocks.

PLL clock mode is selected with PLLSEL bit in the CLKSEL register. When selected, the PLL output clock drives SYSCLK for the main system including the CPU and peripherals. The PLL cannot be turned off if the PLL clock is selected. When PLLSEL is changed, it takes several cycles to make the transition. During the transition, all clocks freeze and CPU activity ceases.

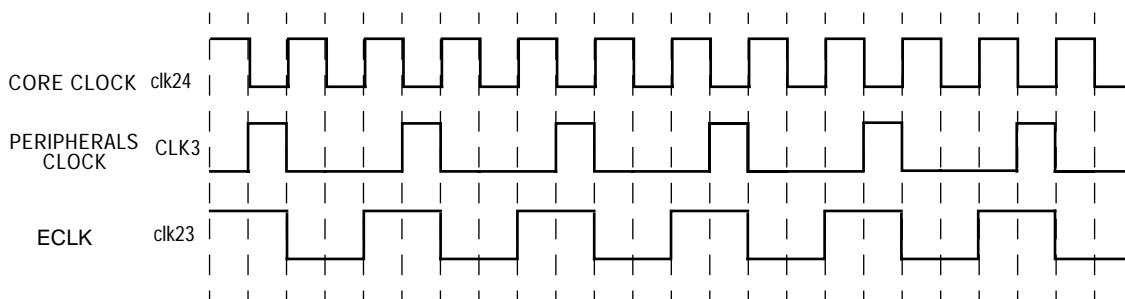

Figure 36 System clocks phase relationship

External clock mode

The oscillator can be completely bypassed and turned off by selecting an external clock source instead. The crystal monitor, PLL, RTI, COP and OSCCLK are driven by this external clock instead of the output of the oscillator. This mode is latched during reset by driving the \overline{XCLKS} (external clock select) input low while the RESET pin is low.

System Reset Generator

The reset sequence is initiated by any of the following events:

- Low level is detected at the \overline{RESET} pin
- COP watchdog timer times out
- Power-on is detected
- Crystal monitor failure is detected and the SCME bit is cleared

External circuitry connected to the \overline{RESET} pin should not include a large capacitance that would interfere with the ability of this signal to rise to a valid logic one within 64 SYSCLK cycles after the low drive is released. Upon detection of any reset, an internal circuit drives the \overline{RESET} pin low and a clocked reset sequence controls when the MCU can begin normal processing.

NOTE: *Entry into reset is asynchronous and does not require a clock. However, the MCU cannot sequence out of reset without a system clock.*

In the case of a crystal monitor failure, the MCU remains static until crystal activity and a stable amplitude signal are detected before the reset recovery sequence starts (\overline{RESET} is driven low throughout this

Clocks and Reset Generator (CRG)

static period). In the case of POR, the reset recovery sequence starts in self clock mode. The internal reset recovery sequence then drives $\overline{\text{RESET}}$ low for 128 SYSCLK cycles and releases the drive to allow $\overline{\text{RESET}}$ to rise. 64 SYSCLK cycles later this circuit samples the $\overline{\text{RESET}}$ pin to see if it has risen to a logic one level. If $\overline{\text{RESET}}$ is low at this point, the reset is assumed to be coming from an external request and the internally latched states of the COP timeout and crystal monitor failure are cleared so the normal reset vector (\$FFFE:FFFF) is taken when $\overline{\text{RESET}}$ is finally released. If $\overline{\text{RESET}}$ is high after this 64 cycle delay, the reset source is tentatively assumed to be either a COP failure or a crystal monitor failure. If the internally latched state of the crystal monitor fail circuit is true, processing begins by fetching the crystal monitor vector (\$FFFC:FFFD). If no crystal monitor failure is indicated, and the latched state of the COP timeout is true, processing begins by fetching the COP vector (\$FFFA:FFFB). If neither crystal monitor fail nor COP timeout are pending, processing begins by fetching the normal reset vector (\$FFFE:FFFF).

Computer Operating Properly (COP) Watchdog

The COP watchdog enables the user to check that a program is running and sequencing properly. When the COP is being used, software is responsible for keeping a free running watchdog timer from timing out. If the watchdog timer times out it is an indication that the software is no longer being executed in the intended sequence; thus a system reset is initiated. The watchdog timer runs with OSCCLK. Three control bits in the COPCTL register allow selection of seven COP time-out periods.

When COP is enabled, the program must write \$55 and \$AA (in this order) to the ARMCOP register during the selected time-out period. Once this is done, the internal COP counter resets to the start of a new time-out period. If the program fails to do this the part will reset. Also, if any value other than \$55 or \$AA is written, the part is immediately reset.

Windowed COP operation is enabled by setting WCOP in the COPCTL register. In this mode, writes to the ARMCOP register to clear the COP timer must occur in the last 25% of the selected time-out period. A premature write will immediately reset the part. See [Figure 37](#).

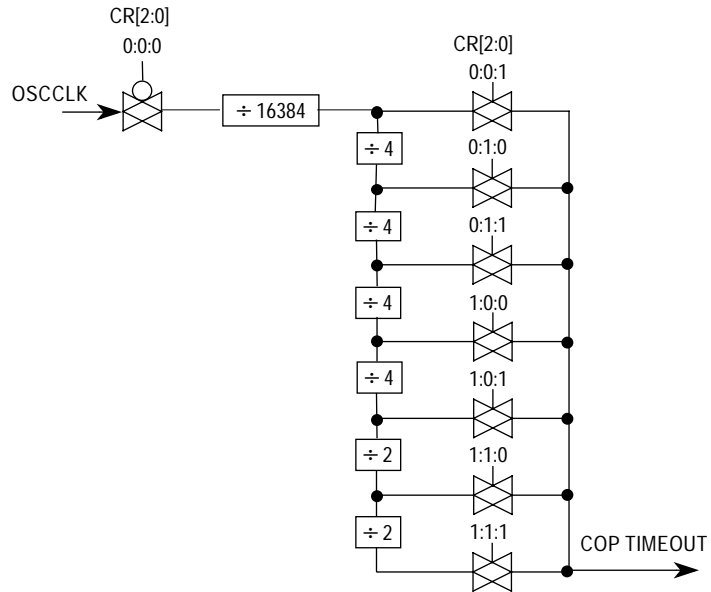

Figure 37 Clock Chain for COP

Power-On detect sequence

Figure 38 and Figure 39 show the power-up sequence for cases when the $\overline{\text{RESET}}$ pin is tied to VDD and when the $\overline{\text{RESET}}$ pin is held low.

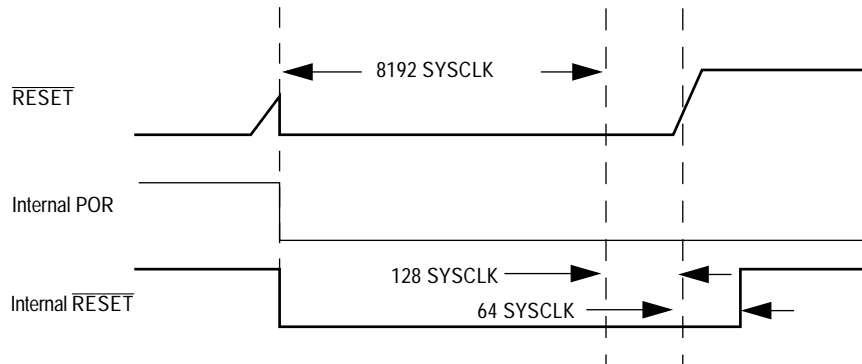

Figure 38 $\overline{\text{RESET}}$ pin tied to VDD (by a pull-up resistor)

Clocks and Reset Generator (CRG)

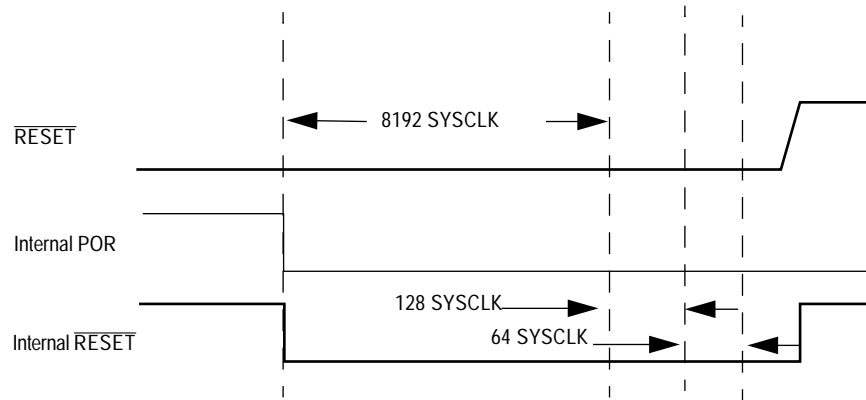

Figure 39 $\overline{\text{RESET}}$ pin held low externally

Real Time Interrupt (RTI)

The RTI can be used to generate a hardware interrupt at a fixed periodic rate. If enabled (by setting RTIE=1), this interrupt will occur at the rate selected by the RTICTL register. The RTI timer runs with OSCCLK. See [Figure 40](#). The RTIF bit is set to one at the end of the RTI time-out period.

NOTE: An RTI period starts from the previous RTI time-out or reset, not from when RTIF is cleared.

To initialize the internal RTI counter, write to the RTICTL register.

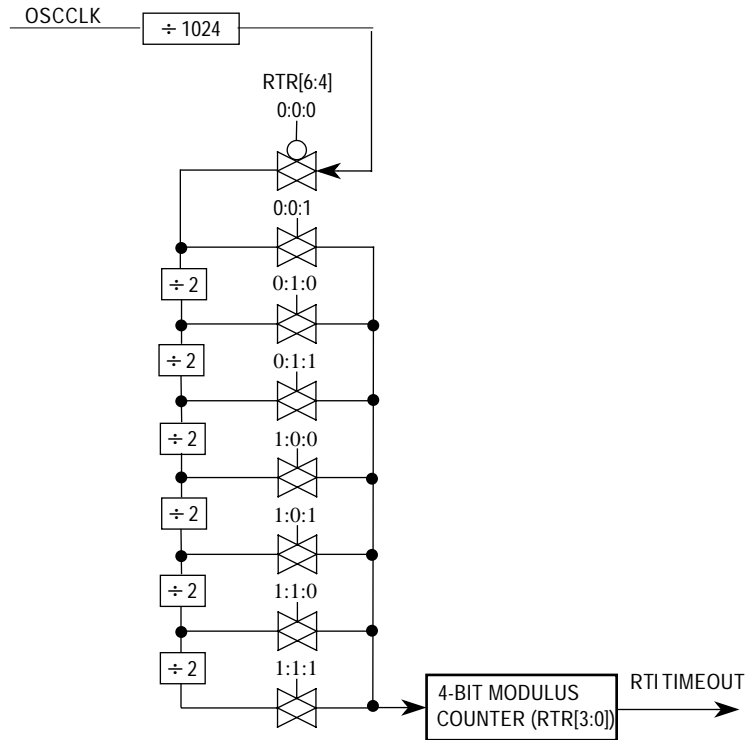

Figure 40 Clock Chain for RTI

Register Descriptions

NOTE: All bits of all registers in this module are completely synchronous to internal clocks during a register read.

CRG Synthesizer Register (SYNR)

The SYNR register controls the multiplication factor of the PLL. If the PLL is on, the count in the loop divider (SYNR) register effectively multiplies up the PLLCLK from the reference frequency by 2 x N, where N is SYNR+1.

$$PLLCLK = 2 \times OSCCLK \times \frac{(SYNR + 1)}{(REFDV + 1)}$$

CAUTION: PLLCLK should not exceed the maximum operating system frequency

Clocks and Reset Generator (CRG)

Address Offset: \$0000

	Bit 7	6	5	4	3	2	1	0
Read:	0	0	SYN5	SYN4	SYN3	SYN2	SYN1	SYN0
Write:	[Unimplemented or reserved]							
Reset:	0	0	0	0	0	0	0	0
	[Unimplemented or reserved]		= Unimplemented or reserved					

Read: anytime.

Write: anytime except if PLLSEL = 1.

Write to this register initializes the lock detector.

CRG Reference Divider Register (REFDV)

The REFDV register provides a finer granularity for the PLL multiplier steps. The count in the reference divider divides OSCCLK frequency by REFDV+1.

Address Offset: \$0001

	Bit 7	6	5	4	3	2	1	0
Read:	0	0	0	0	REFDV3	REFDV2	REFDV1	REFDV0
Write:	[Unimplemented or reserved]							
Reset:	0	0	0	0	0	0	0	0
	[Unimplemented or reserved]				= Unimplemented or reserved			

Read: anytime.

Write: anytime except when PLLSEL = 1.

Write to this register initializes the lock detector.

CRG Test Flags Register (CTFLG)

The CTFLG register is reserved for test mode only.:

Address Offset: \$0002

	Bit 7	6	5	4	3	2	1	0
Read:	TOUT7	TOUT6	TOUT5	TOUT4	TOUT3	TOUT2	TOUT1	TOUT0
Write:								
Reset:	0	0	0	0	0	0	0	0

Read: always read \$00 except in test modes.

Write: only in test modes.

CRG Flags Register (CRGFLG)

Address Offset: \$0003

	Bit 7	6	5	4	3	2	1	0
Read:	RTIF	PORF	0	LOCKIF	LOCK	TRACK	SCMIF	SCM
Write:								
Reset:	0	(1)	0	0	0	0	0	0

= Unimplemented or reserved

1. PORF set to 1 when a power on reset occurs. Unaffected by non-POR resets.

Read anytime. Refer to each bit for write conditions.

RTIF — Real Time Interrupt Flag

The RTIF bit is automatically set to one at the end of every RTI period. This flag can only be cleared by writing a 1. Writing a 0 has no effect.

- 0 = Time-out has not yet occurred.
- 1 = Set when the time-out period is met.

PORF — Power on Reset Flag

The PORF bit is automatically set to one when a power on reset occurs. This flag can only be cleared by writing a 1. Writing a 0 has no effect.

- 0 = Power on reset has not yet occurred

Clocks and Reset Generator (CRG)

1 = Set when a power on reset has occurred

LOCKIF — PLL Lock Interrupt Flag

This flag can only be cleared by writing a 1. Writing a 0 has no effect.

0 = No change in LOCK bit

1 = LOCK condition has changed, either from a locked state to an unlocked state or vice versa.

LOCK — Lock Status

Write never. This bit is cleared in Self-Clocked Mode as the lock detector can not operate without the reference frequency.

0 = PLL VCO is not within the desired tolerance of the target frequency.

1 = After the PLL is turned on, indicates the PLL VCO is within the desired tolerance of the target frequency.

TRACK — Track Status

Write never. This bit is cleared in Self-Clocked Mode as the lock detector can not operate without the reference frequency. See [Acquisition and tracking Modes](#) for more information.

0 = Acquisition mode status.

1 = Tracking mode status.

SCMIF — Self-clock mode Interrupt Flag

The flag can only be cleared by writing a 1. Writing a 0 has no effect.

0 = No change in SCM bit.

1 = SCM condition has changed, either entered or exited self-clock mode.

SCM — Self-clock mode Status

Write never. See [Crystal loss, stop and startup](#) for more information.

0 = MCU is operating normally with OSCCLK available.

1 = PLL self-clock is supplied to the MCU upon loss of OSCCLK.

CRG Interrupt Enable Register (CRGINT)

Address Offset: \$0004

	Bit 7	6	5	4	3	2	1	0
Read:	RTIE	0	0	LOCKIE	0	0	SCMIE	0
Write:								
Reset:	0	0	0	0	0	0	0	0

Read and write anytime.

RTIE — Real Time Interrupt Enable

0 = Interrupt requests from RTI are disabled.

1 = Interrupt will be requested whenever RTIF is set.

LOCKIE — Lock Interrupt Enable

0 = LOCK interrupt requests are disabled.

1 = Interrupt will be requested whenever LOCKIF is set.

SCMIE — Self-clock mode Interrupt Enable

0 = SCM interrupt requests are disabled.

1 = Interrupt will be requested whenever SCMIF is set.

CRG Clock Select Register (CLKSEL)

Address Offset: \$0005

	Bit 7	6	5	4	3	2	1	0
Read:	PLLSEL	PSTP	SYSWAI	ROAWAI	PLLWAI	CWAI	RTIWAI	COPWAI
Write:								
Reset:	0	0	0	0	0	0	0	0

Read anytime. Refer to each bit for write conditions.

Clocks and Reset Generator (CRG)

PLLSEL — PLL selected for system clock

Write anytime except when LOCK is cleared and AUTO is set, or TRACK is cleared and AUTO is cleared. In self-clock mode, the output of the PLLSEL bit is forced to 1, but the PLLSEL bit reads the latched value.

0 = SYSCLK is derived from OSCCLK.

1 = SYSCLK is derived from PLLCLK.

PSTP — Pseudo Stop

User mode: Write once

Test mode: Write anytime

In Pseudo-STOP mode, the oscillator is still running while the MCU is maintained in STOP mode.

0 = Pseudo-STOP oscillator mode is disabled.

1 = Pseudo-STOP oscillator mode is enabled.

NOTE: *Pseudo-STOP allows for faster STOP recovery and reduces the mechanical stress and aging of the resonator in case of frequent STOP conditions at the expense of a slightly increased power consumption.*

SYSWAI — System clocks stop in WAIT mode

User mode: Write once

Test mode: Write anytime

0 = Allows the system clocks to continue running in wait mode.

1 = Disables all the system clocks (CLK24, CLK23, CLK3 and OSCCLK) whenever the part goes into wait mode.

NOTE: *RTI and COP are not affected by SYSWAI bit.*

ROAWAI — Reduced Oscillator Amplitude in WAIT mode

User mode: Write once

Test mode: Write anytime

0 = Normal peak-peak oscillator amplitude in wait mode.

1 = Reduced peak-peak oscillator amplitude in wait mode.

NOTE: *Lower peak to peak oscillator amplitude exhibit lower power consumption but could have adverse effects during any Electro-Magnetic Susceptibility (EMS) tests.*

PLLWAI — PLL stops in WAIT mode

User mode: Write once

Test mode: Write anytime

If PLLWAI is set, PLLON and PLLSEL bits remain set during wait mode but the PLL is powered down. Upon exiting wait mode, an automatic recovery delay is imposed until LOCK is detected. AUTO bit is forced to 1 if PLLWAI is set.

0 = Allows the PLL to keep running in wait mode.

1 = Disables the PLL whenever the part goes into wait mode.

CWAI — CLK24 and CLK23 stop in WAIT mode

User mode: Write once

Test mode: Write anytime

0 = Allows CLK24 and CLK23 to continue running in wait mode.

1 = Disables CLK24 and CLK23 whenever the part goes into wait mode.

RTIWAI — RTI stops in WAIT mode

User mode: Write once

Test mode: Write anytime

0 = Allows the RTI to continue running in wait mode.

1 = Disables and initializes the RTI dividers whenever the part goes into wait mode.

COPWAI — COP stops in WAIT mode

User mode: Write once

Test mode: Write anytime

0 = Allows the COP to continue running in wait mode.

1 = Disables and initializes the COP dividers whenever the part goes into wait mode.

Clocks and Reset Generator (CRG)

CRG PLL Control Register (PLLCTL)

A description of the PLLCTL register follows:

Address Offset: \$0006

	Bit 7	6	5	4	3	2	1	0
Read:	CME	PLLON	AUTO	ACQ	0	0	0	SCME
Write:								
Reset:	1	1	1	1	0	0	0	1

Read anytime. Refer to each bit for write conditions.

CME — Crystal Monitor Enable

Write anytime.

0 = Crystal monitor is disabled.

1 = Crystal monitor is enabled. Slow or stopped clocks (including the stop instruction) will cause a crystal failure reset sequence or self-clock mode.

PLLON — Phase Lock Loop On

Write anytime except when PLLSEL = 1. In self-clock mode, the output of the PLLON bit is forced to 1, but the PLLON bit reads the latched value.

0 = PLL is turned off.

1 = PLL is turned on. If AUTO bit is set, the PLL will lock automatically.

AUTO — Automatic Bandwidth Control

Automatic bandwidth control selects either the high bandwidth (acquisition) mode or the low bandwidth (tracking) mode depending on how close to the desired frequency the VCO is running.

Write anytime except when PLLWAI is set and AUTO bit is forced to 1.

0 = Automatic Mode Control is disabled and the PLL is under software control, using ACQ bit.

1 = Automatic Mode Control is enabled and ACQ bit has no effect.

ACQ — Acquisition

Write anytime. If AUTO =1 this bit has no effect.

- 0 = Low bandwidth software selected
- 1 = High bandwidth software selected

SCME — Self-clock mode enable

User mode: Write once

Test mode: Write anytime

- 0 = Detection of crystal clock failure causes crystal monitor reset
- 1 = Detection of crystal clock failure forces the MCU in self-clock mode.

CRG RTI Control Register (RTICTL)

This register initializes the RTI frequency.

Address Offset: \$0007

	Bit 7	6	5	4	3	2	1	0
Read:	0	RTR6	RTR5	RTR4	RTR3	RTR2	RTR1	RTR0
Write:								
Reset:	0	0	0	0	0	0	0	0

Read and write anytime.

A write to this register will initialize the RTI counter.

RTR[6:4] — Real Time Interrupt Prescale Rate Select

These bits select the prescale rate for the RTI. See [Table 47](#).

RTR[3:0] — Real Time Interrupt Modulus Counter Select

These bits select the modulus counter target value to provide additional granularity. See [Table 47](#).

[Table 47](#) shows all possible divide values selectable by the RTICTL register. The source clock for the RTI is OSCCLK.

Clocks and Reset Generator (CRG)
Table 47 RTI Frequency Divide Rates

RTR[3:0]	RTR[6:4] =							
	000 (OFF)	001 (2 ¹⁰)	010 (2 ¹¹)	011 (2 ¹²)	100 (2 ¹³)	101 (2 ¹⁴)	110 (2 ¹⁵)	111 (2 ¹⁶)
0 (÷1)	OFF*	2 ¹⁰	2 ¹¹	2 ¹²	2 ¹³	2 ¹⁴	2 ¹⁵	2 ¹⁶
1 (÷2)	OFF	2x2 ¹⁰	2x2 ¹¹	2x2 ¹²	2x2 ¹³	2x2 ¹⁴	2x2 ¹⁵	2x2 ¹⁶
2 (÷3)	OFF	3x2 ¹⁰	3x2 ¹¹	3x2 ¹²	3x2 ¹³	3x2 ¹⁴	3x2 ¹⁵	3x2 ¹⁶
3 (÷4)	OFF	4x2 ¹⁰	4x2 ¹¹	4x2 ¹²	4x2 ¹³	4x2 ¹⁴	4x2 ¹⁵	4x2 ¹⁶
4 (÷5)	OFF	5x2 ¹⁰	5x2 ¹¹	5x2 ¹²	5x2 ¹³	5x2 ¹⁴	5x2 ¹⁵	5x2 ¹⁶
5 (÷6)	OFF	6x2 ¹⁰	6x2 ¹¹	6x2 ¹²	6x2 ¹³	6x2 ¹⁴	6x2 ¹⁵	6x2 ¹⁶
6 (÷7)	OFF	7x2 ¹⁰	7x2 ¹¹	7x2 ¹²	7x2 ¹³	7x2 ¹⁴	7x2 ¹⁵	7x2 ¹⁶
7 (÷8)	OFF	8x2 ¹⁰	8x2 ¹¹	8x2 ¹²	8x2 ¹³	8x2 ¹⁴	8x2 ¹⁵	8x2 ¹⁶
8 (÷9)	OFF	9x2 ¹⁰	9x2 ¹¹	9x2 ¹²	9x2 ¹³	9x2 ¹⁴	9x2 ¹⁵	9x2 ¹⁶
9 (÷10)	OFF	10x2 ¹⁰	10x2 ¹¹	10x2 ¹²	10x2 ¹³	10x2 ¹⁴	10x2 ¹⁵	10x2 ¹⁶
10 (÷11)	OFF	11x2 ¹⁰	11x2 ¹¹	11x2 ¹²	11x2 ¹³	11x2 ¹⁴	11x2 ¹⁵	11x2 ¹⁶
11 (÷12)	OFF	12x2 ¹⁰	12x2 ¹¹	12x2 ¹²	12x2 ¹³	12x2 ¹⁴	12x2 ¹⁵	12x2 ¹⁶
12 (÷13)	OFF	13x2 ¹⁰	13x2 ¹¹	13x2 ¹²	13x2 ¹³	13x2 ¹⁴	13x2 ¹⁵	13x2 ¹⁶
13 (÷14)	OFF	14x2 ¹⁰	14x2 ¹¹	14x2 ¹²	14x2 ¹³	14x2 ¹⁴	14x2 ¹⁵	14x2 ¹⁶
14 (÷15)	OFF	15x2 ¹⁰	15x2 ¹¹	15x2 ¹²	15x2 ¹³	15x2 ¹⁴	15x2 ¹⁵	15x2 ¹⁶
15 (÷16)	OFF	16x2 ¹⁰	16x2 ¹¹	16x2 ¹²	16x2 ¹³	16x2 ¹⁴	16x2 ¹⁵	16x2 ¹⁶

* Denotes default value out of reset.

CRG COP Control Register (COPCTL)

A description of the COPCTL register follows:.

Address Offset: \$0008

	Bit 7	6	5	4	3	2	1	0
Read:	WCOP	0	0	0	0	CR2	CR1	CR0
Write:								
Reset:	0	0	0	0	0	0	0	0

Read anytime.

Write once in user mode, anytime in test mode. A write to this register will initialize the COP counter.

WCOP — Window COP mode
 0 = Normal COP operation
 1 = Window COP operation

When set, a write to the ARMCOP register must occur in the last 25% of the selected period. A premature write will also reset the part. As long as all writes occur during this window, \$55 can be written as often as desired. Once \$AA is written after the \$55, the time-out logic restarts and the user must wait until the next window before writing to ARMCOP. [Table 48](#) shows the exact duration of this window for the seven available COP rates.

CR[2:0] — COP Watchdog Timer Rate select
 These bits select the COP time-out rate.

The following equations describe the timeout period as well as the latest and earliest time for the write to the ARMCOP register.

$$\text{TimeOut} = \text{WindowEnd} = \text{OscClkPeriod} \cdot (\text{OscClkDivider} + 3)$$

$$\text{WindowStart} = \text{OscClkPeriod} \cdot ((0.75 \cdot \text{OscClkDivider}) + 9)$$

Clocks and Reset Generator (CRG)

Table 48 COP Watchdog Rates⁽¹⁾

CR2	CR1	CR0	Divide OSCCLK by	Window COP enabled:	
				Window start (OSCCLK Periods)	Window end OSCCLK Periods)
0	0	0	OFF	OFF	OFF
0	0	1	2 ¹⁴	12297	16387
0	1	0	2 ¹⁶	49161	65539
0	1	1	2 ¹⁸	196,617	262,147
1	0	0	2 ²⁰	786,441	1,048,579
1	0	1	2 ²²	3,145,737	4,194,307
1	1	0	2 ²³	6,291,465	8,388,611
1	1	1	2 ²⁴	12,582,921	16,777,219

1. Times are referenced from the previous COP time-out reset (writing \$55/\$AA to the ARMCOP register)

CRG Force and Bypass Test Register (FORBYP)

The FORBYP register is reserved for test mode only.:

Address Offset: \$0009

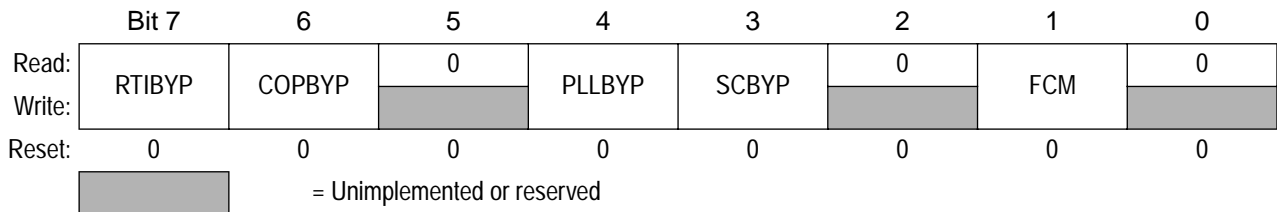

Read: always read \$00 except in test modes.

Write: only in test modes.

CRG Test Control Register (CTCTL)

The CTCTL register is reserved for test mode only.:

Address Offset: \$000A

	Bit 7	6	5	4	3	2	1	0
Read:	TCTL7	TCTL6	TCTL5	TCTL4	TCTL3	TCTL2	TCTL1	TCTL0
Write:								
Reset:	0	0	0	0	0	0	0	0

Read: always read \$00 except in test modes.

Write: only in test modes.

CRG COP Timer Arm/Reset Register (ARMCOP)

This register is used to arm and reset the COP time-out.

Address Offset: \$000E

	Bit 7	6	5	4	3	2	1	0
Read:	0	0	0	0	0	0	0	0
Write:	Bit 7	Bit 6	Bit 5	Bit 4	Bit 3	Bit 2	Bit 1	Bit 0
Reset:	0	0	0	0	0	0	0	0

Always reads \$00.

Writing \$55 to this address is the first step of the COP watchdog sequence.

Writing \$AA to this address is the second step of the COP watchdog sequence.

Other instructions may be executed between these writes but both must be completed in the correct order prior to time-out to avoid a COP reset. Writing any value (when COP is enabled by setting CR[2:0] nonzero) other than \$55 or \$AA causes a COP reset to occur.

External Pin Descriptions

VDDPLL, VSSPLL These pins provide operating voltage and ground for the Phased-Locked Loop. This allows the supply voltage to the PLL to be bypassed independently.

XFC A passive external loop filter must be placed on the control line (XFC pad). The filter is a second-order, low-pass filter to eliminate the VCO input ripple. The value of the external filter network and the reference frequency determines the speed of the corrections and the stability of the PLL.

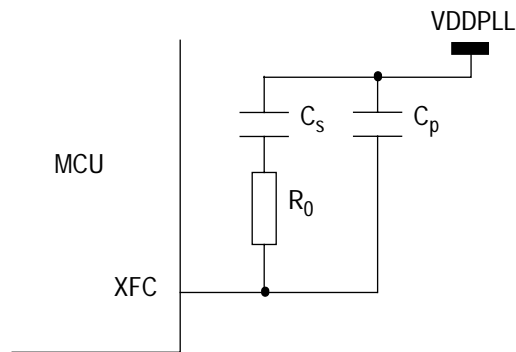

Figure 41 PLL Loop Filter Connections

EXTAL, XTAL These pins provide the interface for either a crystal or a CMOS compatible clock to control the internal clock generator circuitry. EXTAL is the external clock input or the input to the crystal oscillator amplifier. XTAL is the output of the crystal oscillator amplifier. All the device clocks are derived from the EXTAL input frequency.

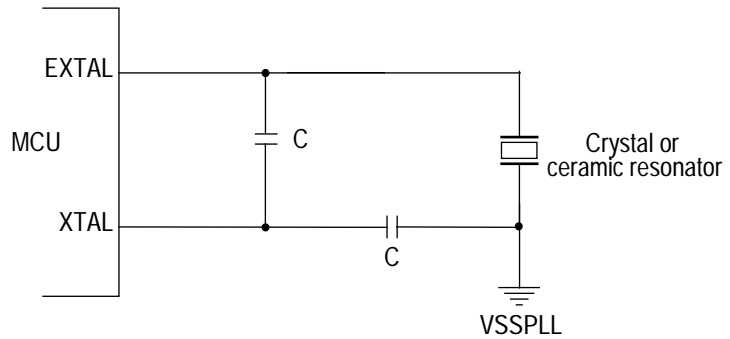

Figure 42 Common Crystal Connections

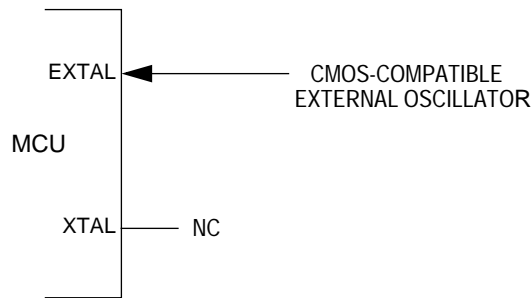

Figure 43 External Oscillator Connections

Reset ($\overline{\text{RESET}}$)

$\overline{\text{RESET}}$ is an active low bidirectional control signal that acts as an input to initialize the MCU to a known start-up state. It also acts as an open-drain output to indicate that an internal failure has been detected in either the crystal monitor or COP watchdog circuit. The MCU goes into reset asynchronously and comes out of reset synchronously. This allows the part to reach a proper reset state even if the clocks have failed, while allowing synchronized operation when starting out of reset. See [System Reset Generator](#).

Clocks and Reset Generator (CRG)

Reset Initialization

When a reset occurs, CRG registers and control bits are changed to known start-up states, as outlined in [Register Descriptions](#).

Interrupt Operation

- Real Time Interrupt** The CRG generates a real time interrupt when the selected interrupt time period elapses. RTI interrupts are locally disabled by setting the RTIE bit to zero. The real time interrupt flag (RTIF) is set to 1 when a timeout occurs, and is cleared to 0 by a write to 1 to the RTIF bit.

- COP (Computer Operating Properly) Watchdog Reset** The device will generate a reset when a COP watchdog failure occurs. This is locally disabled by setting the COP rate select bits in COPCTL (CR2,CR1,CR0) to zero.

- Crystal Monitor Reset** The device will generate a reset when a crystal monitor failure occurs. This is locally disabled by clearing CME bit in PLLCTL register.

Interrupt Vectors The interrupts/reset vectors requested by the CRG are listed below.

Table 49 CRG Interrupt Vectors

Vector Address	Interrupt Source	CCR Mask	Local Enable	HPRIO Value to Elevate
\$FFFF, \$FFFE	Reset	None	None	–
\$FFFC, \$FFFD	crystal monitor reset	None	PLLCTL (CME)	–
\$FFFA, \$FFFB	COP watchdog reset	None	COPCTL (CR[2:0] nonzero)	–
(1)	Real time interrupt	I bit	CRGINT (RTIE)	(2)
(3)	LOCK interrupt	I bit	CRGINT (LOCKIE)	(4)
(5)	SCM interrupt	I bit	CRGINT (SCMIE)	(6)

1. RTI vector address is specific to MCU, refer to MCU specification.
2. RTI HPRIO value is specific to MCU, refer to MCU specification.
3. LOCK vector address is specific to MCU, refer to MCU specification.
4. LOCK HPRIO value is specific to MCU, refer to MCU specification.
5. SCM vector address is specific to MCU, refer to MCU specification.
6. SCM HPRIO value is specific to MCU, refer to MCU specification.

Low Power Options

This section summarizes the low power options available in the CRG sub-block. Low power design practices are implemented where possible.

Run Mode

The RTI can be stopped by setting the associated rate select bits to zero. The COP can be stopped by setting the associated rate select bits to zero in special mode.

Wait Mode

During WAIT mode if SYSWAI bit is set, CLK24, CLK3, CLK23 and OSCCLK to peripherals are not running.

During WAIT mode if CWAI bit is set, CLK24 and CLK23 are not running.

The RTI stays running during WAIT mode unless RTIWAI is set. If the RTIWAI bit is set the RTI dividers get initialized during WAIT mode.

The COP stays running during WAIT mode unless COPWAI is set. If the COPWAI bit is set, the COP dividers get initialized during WAIT mode.

The Crystal Monitor stays running during WAIT mode unless CME is cleared.

The PLL shuts down during WAIT mode and recovers automatically if PLLWAI bit is set.

Stop Mode

All clocks are stopped in STOP mode. The oscillator is disabled in STOP mode unless the PSTP bit is set. All counters and dividers remain frozen but do not initialize.

Pulse Width Modulator (PWM)

Contents

Overview	297
Features	298
Block Diagram	299
External Pin Descriptions	299
Register Map	300
Register Descriptions	302
Functional Description	324
Reset Initialization	338
Modes of Operation	339
Low Power Options	340
Interrupt Operation	340

Overview

The Pulse Width Modulation (PWM) definition is based on the MC68HC11KD2 and the HC12 PWM definitions. This PWM contains the basic features from the HC11 with some of the enhancements incorporated on the HC12. In addition, the module is now expanded to eight channels with independent control of left and center aligned outputs on each channel. In all basic functionality, it will behave similarly to the HC11 PWM with the additional HC12 PWM features of center aligned output mode and four available clock sources.

The PWM module contains eight channels. Each of these channels has a programmable period and duty cycle as well as a dedicated counter. A flexible clock select scheme allows a total of four different clock sources to be used with the counters. Each of the modulators can create independent continuous waveforms with software-selectable duty rates

Pulse Width Modulator (PWM)

from 0% to 100%. The PWM outputs can be programmed as left aligned outputs or center aligned outputs.

Features

- Eight independent PWM channels with programmable period and duty cycle.
- Dedicated counter for each PWM channel.
- Programmable PWM enable/disable for each channel.
- Software selection of PWM duty pulse polarity for each channel.
- Period and duty cycle are double buffered. Change takes effect when the end of the effective period is reached (PWM counter reaches zero) or when the channel is disabled.
- Programmable center or left aligned outputs on individual channels.
- Eight 8-bit channel or four 16-bit channel PWM resolution.
- Four clock sources (A, B, SA and SB) provide for a wide range of frequencies.
- Programmable Clock Select Logic.
- Emergency shutdown.

Block Diagram

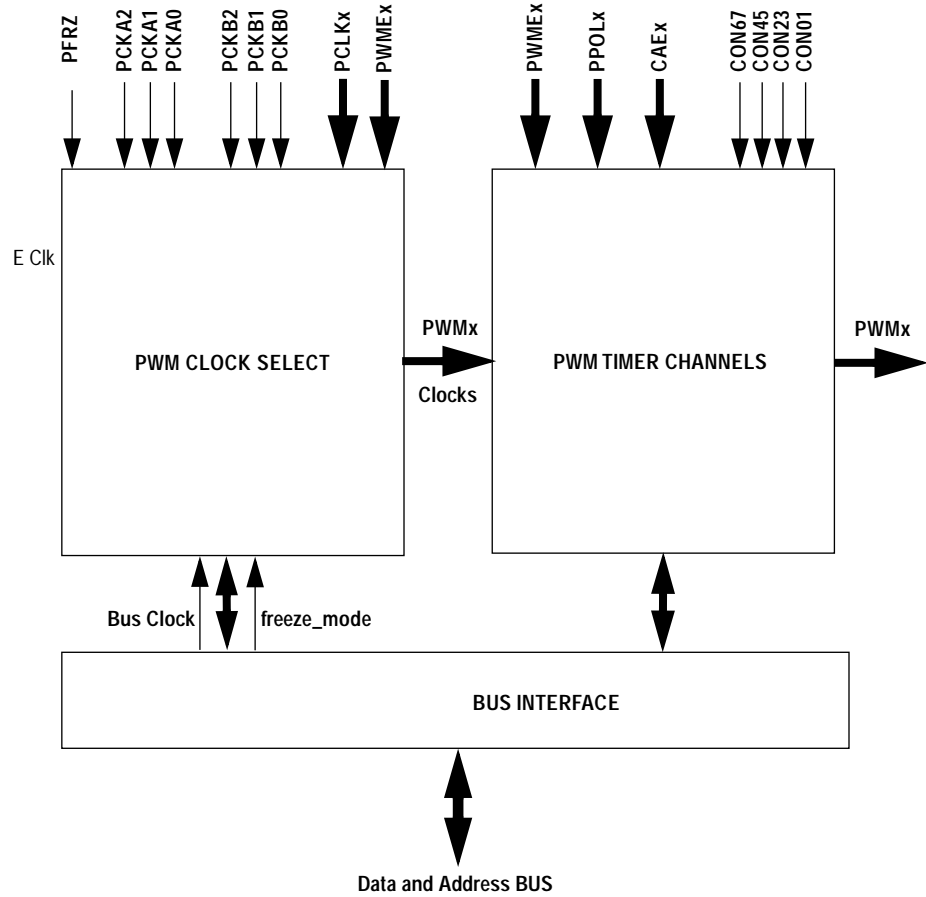

Figure 44 Pulse Width Modulation Block Diagram

External Pin Descriptions

The PWM module has no external pins.

Pulse Width Modulator (PWM)
Register Map

This section describes the content of the registers in the PWM. The base address of the PWM module is determined at the MCU level when the MCU is defined. The register decode map is fixed and begins at the first address of the module address offset. The figure below shows the registers associated with the PWM and their relative offset from the base address. The register detail description follows the order they appear in the register map.

Reserved bits within a register will always read as 0 and the write will be unimplemented. Unimplemented functions are indicated by shaded bits.

Register Name	Bit 7	Bit 6	Bit 5	Bit 4	Bit 3	Bit 2	Bit 1	Bit 0	Address Offset
PWME	Read: PWME7 Write: PWME7	PWME6	PWME5	PWME4	PWME3	PWME2	PWME1	PWME0	\$0000
PWMPOL	Read: PPOL7 Write: PPOL7	PPOL6	PPOL5	PPOL4	PPOL3	PPOL2	PPOL1	PPOL0	\$0001
PWMCLK	Read: PCLK7 Write: PCLK7	PCLK6	PCLK5	PCLK4	PCLK3	PCLK2	PCLK1	PCLK0	\$0002
PWMPRCLK	Read: 0 Write: 0	PCKB2	PCKB1	PCKB0	0	PCKA2	PCKA1	PCKA0	\$0003
PWMC AE	Read: CAE7 Write: CAE7	CAE6	CAE5	CAE4	CAE3	CAE2	CAE1	CAE0	\$0004
PWMCTL	Read: CON67 Write: CON67	CON45	CON23	CON01	PSWAI	PFRZ	0	0	\$0005
PWMTST	Read: 0 Write: 0	0	0	0	0	0	0	0	\$0006
PWMPRSC	Read: 0 Write: 0	0	0	0	0	0	0	0	\$0007
PWMSCLA	Read: Bit 7 Write: Bit 7	6	5	4	3	2	1	Bit 0	\$0008
PWMSCLB	Read: Bit 7 Write: Bit 7	6	5	4	3	2	1	Bit 0	\$0009
PWMSCNTA	Read: 0 Write: 0	0	0	0	0	0	0	0	\$000A
PWMSCNTB	Read: 0 Write: 0	0	0	0	0	0	0	0	\$000B

= Unimplemented

Figure 45 PWM Register Map

Register Name		Bit 7	Bit 6	Bit 5	Bit 4	Bit 3	Bit 2	Bit 1	Bit 0	Address Offset
PWMCNT0	Read:	Bit 7	6	5	4	3	2	1	Bit 0	\$000C
	Write:	0	0	0	0	0	0	0	0	
PWMCNT1	Read:	Bit 7	6	5	4	3	2	1	Bit 0	\$000D
	Write:	0	0	0	0	0	0	0	0	
PWMCNT2	Read:	Bit 7	6	5	4	3	2	1	Bit 0	\$000E
	Write:	0	0	0	0	0	0	0	0	
PWMCNT3	Read:	Bit 7	6	5	4	3	2	1	Bit 0	\$000F
	Write:	0	0	0	0	0	0	0	0	
PWMCNT4	Read:	Bit 7	6	5	4	3	2	1	Bit 0	\$0010
	Write:	0	0	0	0	0	0	0	0	
PWMCNT5	Read:	Bit 7	6	5	4	3	2	1	Bit 0	\$0011
	Write:	0	0	0	0	0	0	0	0	
PWMCNT6	Read:	Bit 7	6	5	4	3	2	1	Bit 0	\$0012
	Write:	0	0	0	0	0	0	0	0	
PWMCNT7	Read:	Bit 7	6	5	4	3	2	1	Bit 0	\$0013
	Write:	0	0	0	0	0	0	0	0	
PWMPER0	Read:	Bit 7	6	5	4	3	2	1	Bit 0	\$0014
	Write:									
PWMPER1	Read:	Bit 7	6	5	4	3	2	1	Bit 0	\$0015
	Write:									
PWMPER2	Read:	Bit 7	6	5	4	3	2	1	Bit 0	\$0016
	Write:									
PWMPER3	Read:	Bit 7	6	5	4	3	2	1	Bit 0	\$0017
	Write:									
PWMPER4	Read:	Bit 7	6	5	4	3	2	1	Bit 0	\$0018
	Write:									
PWMPER5	Read:	Bit 7	6	5	4	3	2	1	Bit 0	\$0019
	Write:									
PWMPER6	Read:	Bit 7	6	5	4	3	2	1	Bit 0	\$001A
	Write:									
PWMPER7	Read:	Bit 7	6	5	4	3	2	1	Bit 0	\$001B
	Write:									
PWMDTY0	Read:	Bit 7	6	5	4	3	2	1	Bit 0	\$001C
	Write:									
PWMDTY1	Read:	Bit 7	6	5	4	3	2	1	Bit 0	\$001D
	Write:									
PWMDTY2	Read:	Bit 7	6	5	4	3	2	1	Bit 0	\$001E
	Write:									
PWMDTY3	Read:	Bit 7	6	5	4	3	2	1	Bit 0	\$001F
	Write:									

= Unimplemented

Figure 45 PWM Register Map

Pulse Width Modulator (PWM)

Register Name		Bit 7	Bit 6	Bit 5	Bit 4	Bit 3	Bit 2	Bit 1	Bit 0	Address Offset
PWMDTY4	Read:	Bit 7	6	5	4	3	2	1	Bit 0	\$0020
	Write:									
PWMDTY5	Read:	Bit 7	6	5	4	3	2	1	Bit 0	\$0021
	Write:									
PWMDTY6	Read:	Bit 7	6	5	4	3	2	1	Bit 0	\$0022
	Write:									
PWMDTY7	Read:	Bit 7	6	5	4	3	2	1	Bit 0	\$0023
	Write:									
PWMSDN	Read:	PWMIF	PWMIE	0	PWMLVL	0	PWM7IN	PWM7INL	PWM7ENA	\$0024
	Write:			PWMRSTRT						
RESERVED1	Read:	0	0	0	0	0	0	0	0	\$0025
	Write:									
RESERVED2	Read:	0	0	0	0	0	0	0	0	\$0026
	Write:									
RESERVED3	Read:	0	0	0	0	0	0	0	0	\$0027
	Write:									

= Unimplemented

Figure 45 PWM Register Map

NOTE: *Register Address = Base Address + Address Offset, where the Base Address is defined at the MCU level and the Address Offset is defined at the module level.*

Register Descriptions

This section describes in detail all the registers and register bits in the PWM module.

NOTE: *All bits of all registers in this module are completely synchronous to internal clocks during a register read.*

PWM Enable Register (PWME)

Address Offset: \$0000

	Bit 7	6	5	4	3	2	1	Bit 0
Read:	PWME7	PWME6	PWME5	PWME4	PWME3	PWME2	PWME1	PWME0
Write:								
Reset:	0	0	0	0	0	0	0	0

Each PWM channel has an enable bit (PWME_x) to start its waveform output. When any of the PWME_x bits are set (PWME_x=1), the associated PWM output is enabled immediately. However, the actual PWM waveform is not available on the associated PWM output until its clock source begins its next cycle due to the synchronization of PWME_x and the clock source.

The first PWM cycle after enabling the channel can be irregular.

An exception to this is when channels are concatenated. Once concatenated mode is enabled (CON_{xx} bits set in PWMCTL register) then enabling/disabling the corresponding 16-bit PWM channel is controlled by the low order PWME_x bit. In this case, the high order bytes PWME_x bits have no effect and their corresponding PWM output lines are disabled.

Read: anytime

Write: anytime

PWME7 — Pulse Width Channel 7 Enable

1 = Pulse Width channel 7 is enabled. The pulse modulated signal becomes available at PWM output line7 when its clock source begins its next cycle.

0 = Pulse Width channel 7 is disabled.

PWME6 — Pulse Width Channel 6 Enable

1 = Pulse Width channel 6 is enabled. The pulse modulated signal becomes available at port PWM output line6 when its clock source begins its next cycle. If CON67=1, then bit has no effect and PWM output line6 is disabled.

0 = Pulse Width channel 6 is disabled.

Pulse Width Modulator (PWM)

PWME5 — Pulse Width Channel 5 Enable

1 = Pulse Width channel 5 is enabled. The pulse modulated signal becomes available at PWM, o/p bit 5 when its clock source begins its next cycle.

0 = Pulse Width channel 5 is disabled.

PWME4 — Pulse Width Channel 4 Enable

1 = Pulse Width channel 4 is enabled. The pulse modulated signal becomes available at PWM, o/p bit 4 when its clock source begins its next cycle. If CON45=1, then bit has no effect and PWM output line4 is disabled.

0 = Pulse Width channel 4 is disabled.

PWME3 — Pulse Width Channel 3 Enable

1 = Pulse Width channel 3 is enabled. The pulse modulated signal becomes available at PWM, o/p bit 3 when its clock source begins its next cycle.

0 = Pulse Width channel 3 is disabled.

PWME2 — Pulse Width Channel 2 Enable

1 = Pulse Width channel 2 is enabled. The pulse modulated signal becomes available at PWM, o/p bit 2 when its clock source begins its next cycle. If CON23=1, then bit has no effect and PWM output line2 is disabled.

0 = Pulse Width channel 2 is disabled.

PWME1 — Pulse Width Channel 1 Enable

1 = Pulse Width channel 1 is enabled. The pulse modulated signal becomes available at PWM, o/p bit 1 when its clock source begins its next cycle.

0 = Pulse Width channel 1 is disabled.

PWME0 — Pulse Width Channel 0 Enable

1 = Pulse Width channel 0 is enabled. The pulse modulated signal becomes available at PWM, o/p bit 0 when its clock source begins its next cycle. If CON01=1, then bit has no effect and PWM output line0 is disabled.

0 = Pulse Width channel 0 is disabled.

**PWM Polarity
Register (PWMPOL)**

Address Offset: \$0001

	Bit 7	6	5	4	3	2	1	Bit 0
Read:	PPOL7	PPOL6	PPOL5	PPOL4	PPOL3	PPOL2	PPOL1	PPOL0
Write:								
Reset:	0	0	0	0	0	0	0	0

The starting polarity of each PWM channel waveform is determined by the associated PPOLx bit in the PWMPOL register. If the polarity bit is one, the PWM channel output is high at the beginning of the cycle and then goes low when the duty count is reached. Conversely, if the polarity bit is zero, the output starts low and then goes high when the duty count is reached.

Read: anytime

Write: anytime

CAUTION: *PPOLx register bits can be written anytime. If the polarity is changed while a PWM signal is being generated, a truncated or stretched pulse can occur during the transition.*

PPOL7 — Pulse Width Channel 7 Polarity

1 = PWM channel 7 output is high at the beginning of the period, then goes low when the duty count is reached.

0 = PWM channel 7 output is low at the beginning of the period, then goes high when the duty count is reached.

PPOL6 — Pulse Width Channel 6 Polarity

1 = PWM channel 6 output is high at the beginning of the period, then goes low when the duty count is reached.

0 = PWM channel 6 output is low at the beginning of the period, then goes high when the duty count is reached.

PPOL5 — Pulse Width Channel 5 Polarity

1 = PWM channel 5 output is high at the beginning of the period, then goes low when the duty count is reached.

0 = PWM channel 5 output is low at the beginning of the period, then goes high when the duty count is reached.

Pulse Width Modulator (PWM)

PPOL4 — Pulse Width Channel 4 Polarity

1 = PWM channel 4 output is high at the beginning of the period, then goes low when the duty count is reached.

0 = PWM channel 4 output is low at the beginning of the period, then goes high when the duty count is reached.

PPOL3 — Pulse Width Channel 3 Polarity

1 = PWM channel 3 output is high at the beginning of the period, then goes low when the duty count is reached.

0 = PWM channel 3 output is low at the beginning of the period, then goes high when the duty count is reached.

PPOL2 — Pulse Width Channel 2 Polarity

1 = PWM channel 2 output is high at the beginning of the period, then goes low when the duty count is reached.

0 = PWM channel 2 output is low at the beginning of the period, then goes high when the duty count is reached.

PPOL1 — Pulse Width Channel 1 Polarity

1 = PWM channel 1 output is high at the beginning of the period, then goes low when the duty count is reached.

0 = PWM channel 1 output is low at the beginning of the period, then goes high when the duty count is reached.

PPOL0 — Pulse Width Channel 0 Polarity

1 = PWM channel 0 output is high at the beginning of the period, then goes low when the duty count is reached.

0 = PWM channel 0 output is low at the beginning of the period, then goes high when the duty count is reached.

PWM Clock Select Register (PWMCLK)

Address Offset: \$0002

	Bit 7	6	5	4	3	2	1	Bit 0
Read:	PCLK7	PCLK6	PCLK5	PCLK4	PCLK3	PCLK2	PCLK1	PCLK0
Write:								
Reset:	0	0	0	0	0	0	0	0

Each PWM channel has a choice of two clocks to use as the clock source for that channel as described below.

Read: anytime

Write: anytime

CAUTION: Register bits PCLK0 to PCLK7 can be written anytime. If a clock select is changed while a PWM signal is being generated, a truncated or stretched pulse can occur during the transition.

PCLK7 — Pulse Width Channel 7 Clock Select

1 = Clock SB is the clock source for PWM channel 7.

0 = Clock B is the clock source for PWM channel 7.

PCLK6 — Pulse Width Channel 6 Clock Select

1 = Clock SB is the clock source for PWM channel 6.

0 = Clock B is the clock source for PWM channel 6.

PCLK5 — Pulse Width Channel 5 Clock Select

1 = Clock SA is the clock source for PWM channel 5.

0 = Clock A is the clock source for PWM channel 5.

PCLK4 — Pulse Width Channel 4 Clock Select

1 = Clock SA is the clock source for PWM channel 4.

0 = Clock A is the clock source for PWM channel 4.

PCLK3 — Pulse Width Channel 3 Clock Select

1 = Clock SB is the clock source for PWM channel 3.

0 = Clock B is the clock source for PWM channel 3.

Pulse Width Modulator (PWM)

PCLK2 — Pulse Width Channel 2 Clock Select
 1 = Clock SB is the clock source for PWM channel 2.
 0 = Clock B is the clock source for PWM channel 2.

PCLK1 — Pulse Width Channel 1 Clock Select
 1 = Clock SA is the clock source for PWM channel 1.
 0 = Clock A is the clock source for PWM channel 1.

PCLK0 — Pulse Width Channel 0 Clock Select
 1 = Clock SA is the clock source for PWM channel 0.
 0 = Clock A is the clock source for PWM channel 0.

**PWM Prescale
 Clock Select
 Register
 (PWMPRCLK)**

Address Offset: \$0003

	Bit 7	6	5	4	3	2	1	Bit 0
Read:	0	PCKB2	PCKB1	PCKB0	0	PCKA2	PCKA1	PCKA0
Write:								
Reset:	0	0	0	0	0	0	0	0

= Reserved or unimplemented

This register selects the prescale clock source for clocks A and B independently.

Read: anytime
 Write: anytime

CAUTION: *PCKB2–0 and PCKA2–0 register bits can be written anytime. If the clock pre-scale is changed while a PWM signal is being generated, a truncated or stretched pulse can occur during the transition.*

PCKB2–PCKB0 — Prescaler Select for Clock B

Clock B is one of two clock sources which can be used for channels 2, 3, 6, or 7. These three bits determine the rate of clock B, as shown in the following table.

Table 50 Clock B Prescaler Selects

PCKB2	PCKB1	PCKB0	Value of Clock B
0	0	0	E
0	0	1	E / 2
0	1	0	E / 4
0	1	1	E / 8
1	0	0	E / 16
1	0	1	E / 32
1	1	0	E / 64
1	1	1	E / 128

PCKA2–PCKA0 — Prescaler Select for Clock A

Clock A is one of two clock sources which can be used for channels 0, 1, 4, or 5. These three bits determine the rate of clock A, as shown in the following table.

Table 51 Clock A Prescaler Selects

PCKA2	PCKA1	PCKA0	Value of Clock A
0	0	0	E
0	0	1	E / 2
0	1	0	E / 4
0	1	1	E / 8
1	0	0	E / 16
1	0	1	E / 32
1	1	0	E / 64
1	1	1	E / 128

Pulse Width Modulator (PWM)

**PWM Center Align
Enable Register
(PWMCAE)**

Address Offset: \$0004

	Bit 7	6	5	4	3	2	1	Bit 0
Read:	CAE7	CAE6	CAE5	CAE4	CAE3	CAE2	CAE1	CAE0
Write:								
Reset:	0	0	0	0	0	0	0	0

The PWMCAE register contains eight control bits for the selection of center aligned outputs or left aligned outputs for each PWM channel. If the CAEx bit is set to a one, the corresponding PWM output will be center aligned. If the CAEx bit is cleared, the corresponding PWM output will be left aligned. Reference [Left Aligned Outputs](#) and [Center Aligned Outputs](#) for a more detailed description of the PWM output modes.

Read: anytime

Write: anytime

CAUTION: *Write these bits only when the corresponding channel is disabled.*

CAE7 — Center Aligned Output Mode on channel 7
 1 = Channel 7 operates in Center Aligned Output Mode.
 0 = Channel 7 operates in Left Aligned Output Mode.

CAE6 — Center Aligned Output Mode on channel 6
 1 = Channel 6 operates in Center Aligned Output Mode.
 0 = Channel 6 operates in Left Aligned Output Mode.

CAE5 — Center Aligned Output Mode on channel 5
 1 = Channel 5 operates in Center Aligned Output Mode.
 0 = Channel 5 operates in Left Aligned Output Mode.

CAE4 — Center Aligned Output Mode on channel 4
 1 = Channel 4 operates in Center Aligned Output Mode.
 0 = Channel 4 operates in Left Aligned Output Mode.

CAE3 — Center Aligned Output Mode on channel 3
 1 = Channel 3 operates in Center Aligned Output Mode.
 0 = Channel 3 operates in Left Aligned Output Mode.

- CAE2 — Center Aligned Output Mode on channel 2
1 = Channel 2 operates in Center Aligned Output Mode.
0 = Channel 2 operates in Left Aligned Output Mode.
- CAE1 — Center Aligned Output Mode on channel 1
1 = Channel 1 operates in Center Aligned Output Mode.
0 = Channel 1 operates in Left Aligned Output Mode.
- CAE0 — Center Aligned Output Mode on channel 0
1 = Channel 0 operates in Center Aligned Output Mode.
0 = Channel 0 operates in Left Aligned Output Mode.

PWM Control Register (PWMCTL)

Address Offset: \$0005

	Bit 7	6	5	4	3	2	1	Bit 0
Read:	CON67	CON45	CON23	CON01	PSWAI	PFRZ	0	0
Write:								
Reset:	0	0	0	0	0	0	0	0

The PWMCTL register provides for various control of the PWM module.
Read: anytime
Write: anytime

There are four control bits for concatenation, each of which is used to concatenate a pair of PWM channels into one 16-bit channel. When channels 6 and 7 are concatenated, channel 6 registers become the high order bytes of the double byte channel as shown in [Figure 52](#). Similarly, when channels 4 and 5 are concatenated, channel 4 registers become the high order bytes of the double byte channel. When channels 2 and 3 are concatenated, channel 2 registers become the high order bytes of the double byte channel. When channels 0 and 1 are concatenated, channel 0 registers become the high order bytes of the double byte channel.

Reference [PWM 16-Bit Functions](#) for a more detailed description of the concatenation PWM Function.

Pulse Width Modulator (PWM)

CAUTION: *Change these bits only when both corresponding channels are disabled.*

CON67 — Concatenate channels 6 and 7

1 = Channels 6 and 7 are concatenated to create one 16-bit PWM channel. Channel 6 becomes the high order byte and channel 7 becomes the low order byte. Channel 7 output pin is used as the output for this 16-bit PWM (bit 7 of port PWMP). Channel 7 clock select control-bit determines the clock source, channel 7 polarity bit determines the polarity, channel 7 enable bit enables the output and channel 7 center aligned enable bit determines the output mode.

0 = Channels 6 and 7 are separate 8-bit PWMs.

CON45 — Concatenate channels 4 and 5

1 = Channels 4 and 5 are concatenated to create one 16-bit PWM channel. Channel 4 becomes the high order byte and channel 5 becomes the low order byte. Channel 5 output pin is used as the output for this 16-bit PWM (bit 5 of port PWMP). Channel 5 clock select control-bit determines the clock source, channel 5 polarity bit determines the polarity, channel 5 enable bit enables the output and channel 5 center aligned enable bit determines the output mode.

0 = Channels 4 and 5 are separate 8-bit PWMs.

CON23 — Concatenate channels 2 and 3

1 = Channels 2 and 3 are concatenated to create one 16-bit PWM channel. Channel 2 becomes the high order byte and channel 3 becomes the low order byte. Channel 3 output pin is used as the output for this 16-bit PWM (bit 3 of port PWMP). Channel 3 clock select control-bit determines the clock source, channel 3 polarity bit determines the polarity, channel 3 enable bit enables the output and channel 3 center aligned enable bit determines the output mode.

0 = Channels 2 and 3 are separate 8-bit PWMs.

CON01 — Concatenate channels 0 and 1

1 = Channels 0 and 1 are concatenated to create one 16-bit PWM channel. Channel 0 becomes the high order byte and channel 1 becomes the low order byte. Channel 1 output pin is used as

the output for this 16-bit PWM (bit 1 of port PWMP). Channel 1 clock select control-bit determines the clock source, channel 1 polarity bit determines the polarity, channel 1 enable bit enables the output and channel 1 center aligned enable bit determines the output mode.

0 = Channels 0 and 1 are separate 8-bit PWMs.

PSWAI — PWM Stops in Wait Mode

Enabling this bit allows for lower power consumption in Wait Mode by disabling the input clock to the prescaler.

1 = Stop the input clock to the prescaler whenever the MCU is in Wait Mode.

0 = Allow the clock to the prescaler to continue while in wait mode.

PFRZ — PWM Counters Stop in Freeze Mode

1 = Disable PWM input clock to the prescaler whenever the part is in freeze mode. This is useful for emulation.

0 = Allow PWM to continue while in freeze mode.

Reserved Register (PWMTST)

Address Offset: \$0006

	Bit 7	6	5	4	3	2	1	Bit 0
Read:	0	0	0	0	0	0	0	0
Write:								
Reset:	0	0	0	0	0	0	0	0

= Reserved or unimplemented

This register is reserved for factory testing of the PWM module and is not available in normal modes.

Read: always read \$00 in normal modes

Write: unimplemented in normal modes

WARNING: *Writing to this register when in special modes can alter the PWM functionality.*

Pulse Width Modulator (PWM)

**Reserved Register
(PWMPRSC)**

Address Offset: \$0007

	Bit 7	6	5	4	3	2	1	Bit 0
Read:	0	0	0	0	0	0	0	0
Write:								
Reset:	0	0	0	0	0	0	0	0

= Reserved or unimplemented

This register is reserved for factory testing of the PWM module and is not available in normal modes.

Read: always read \$00 in normal modes

Write: unimplemented in normal modes

WARNING: *Writing to this register when in special modes can alter the PWM functionality.*

**PWM Scale A
Register
(PWMSCLA)**

Address Offset: \$0008

	Bit 7	6	5	4	3	2	1	Bit 0
Read:	Bit 7	6	5	4	3	2	1	Bit 0
Write:	Bit 7	6	5	4	3	2	1	Bit 0
Reset:	0	0	0	0	0	0	0	0

PWMSCLA is the programmable scale value used in scaling clock A to generate clock SA. Clock SA is generated by taking clock A, dividing it by the value in the PWMSCLA register and dividing that by two.

$$\text{Clock SA} = \text{Clock A} / (2 * \text{PWMSCLA})$$

NOTE: When PWMSCLA = \$00, PWMSCLA value is considered a full scale value of 256. Clock A is thus divided by 512.

Any value written to this register will cause the scale counter to load the new scale value (PWMSCLA).

Read: anytime

Write: anytime (causes the scale counter to load the PWMSCLA value)

**PWM Scale B
Register
(PWMSCLB)**

Address Offset: \$0009

	Bit 7	6	5	4	3	2	1	Bit 0
Read:	Bit 7	6	5	4	3	2	1	Bit 0
Write:	Bit 7	6	5	4	3	2	1	Bit 0
Reset:	0	0	0	0	0	0	0	0

PWMSCLB is the programmable scale value used in scaling clock B to generate clock SB. Clock SB is generated by taking clock B, dividing it by the value in the PWMSCLB register and dividing that by two.

$$\text{Clock SB} = \text{Clock B} / (2 * \text{PWMSCLB})$$

NOTE: When PWMSCLB = \$00, PWMSCLB value is considered a full scale value of 256. Clock B is thus divided by 512.

Any value written to this register will cause the scale counter to load the new scale value (PWMSCLB).

Read: anytime

Write: anytime (causes the scale counter to load the PWMSCLB value)

**Reserved Registers
(PWMSCLTx)**

Address Offset: \$000A–\$000B

	Bit 7	6	5	4	3	2	1	Bit 0
Read:	0	0	0	0	0	0	0	0
Write:	0	0	0	0	0	0	0	0
Reset:	0	0	0	0	0	0	0	0

= Reserved or unimplemented

Pulse Width Modulator (PWM)

These registers are reserved for factory testing of the PWM module and are not available in normal modes.

Read: always read \$00 in normal modes

Write: unimplemented in normal modes

WARNING: *Writing to this register when in special modes can alter the PWM functionality.*

PWM Channel Counter Registers (PWMCNTx)

Each channel has a dedicated 8-bit up/down counter which runs at the rate of the selected clock source. The counter can be read at any time without affecting the count or the operation of the PWM channel. In left aligned output mode, the counter counts from 0 to the value in the period register – 1. In center aligned output mode, the counter counts from 0 up to the value in the period register and then back down to 0.

Any value written to the counter causes the counter to reset to \$00, the counter direction to be set to up, the immediate load of both duty and period registers with values from the buffers, and the output to change according to the polarity bit. The counter is also cleared at the end of the effective period (see Sections [Left Aligned Outputs](#) and [Center Aligned Outputs](#) for more details). When the channel is disabled (PWME_x=0), the PWMCNT_x register does not count. When a channel becomes enabled (PWME_x=1), the associated PWM counter starts at the count in the PWMCNT_x register. For more detailed information on the operation of the counters, reference [PWM Timer Counters](#).

In concatenated mode, writes to the 16-bit counter by using a 16-bit access or writes to either the low or high order byte of the counter will reset the 16-bit counter. Reads of the 16-bit counter must be made by 16-bit access to maintain data coherency

CAUTION: *Writing to the counter while the channel is enabled can cause an irregular PWM cycle to occur.*

	Bit 7	6	5	4	3	2	1	Bit 0
Address	\$000C							PWMCNT0
Read:	Bit 7	6	5	4	3	2	1	Bit 0
Write:	0	0	0	0	0	0	0	0
Reset:	0	0	0	0	0	0	0	0
Address	\$000D							PWMCNT1
Read:	Bit 7	6	5	4	3	2	1	Bit 0
Write:	0	0	0	0	0	0	0	0
Reset:	0	0	0	0	0	0	0	0
Address	\$000E							PWMCNT2
Read:	Bit 7	6	5	4	3	2	1	Bit 0
Write:	0	0	0	0	0	0	0	0
Reset:	0	0	0	0	0	0	0	0
Address	\$000F							PWMCNT3
Read:	Bit 7	6	5	4	3	2	1	Bit 0
Write:	0	0	0	0	0	0	0	0
Reset:	0	0	0	0	0	0	0	0
Address	\$0010							PWMCNT4
Read:	Bit 7	6	5	4	3	2	1	Bit 0
Write:	0	0	0	0	0	0	0	0
Reset:	0	0	0	0	0	0	0	0
Address	\$0011							PWMCNT5
Read:	Bit 7	6	5	4	3	2	1	Bit 0
Write:	0	0	0	0	0	0	0	0
Reset:	0	0	0	0	0	0	0	0
Address	\$0012							PWMCNT6
Read:	Bit 7	6	5	4	3	2	1	Bit 0
Write:	0	0	0	0	0	0	0	0
Reset:	0	0	0	0	0	0	0	0
Address	\$0013							PWMCNT7
Read:	Bit 7	6	5	4	3	2	1	Bit 0
Write:	0	0	0	0	0	0	0	0
Reset:	0	0	0	0	0	0	0	0

Read: anytime

Write: anytime (any value written causes PWM counter to be reset to \$00)

Pulse Width Modulator (PWM)
**PWM Channel
Period Registers
(PWMPERx)**

There is a dedicated period register for each channel. The value in this register determines the period of the associated PWM channel.

The period registers for each channel are double buffered so that if they change while the channel is enabled, the change will NOT take effect until one of the following occurs:

- The effective period ends
- The counter is written (counter resets to \$00)
- The channel is disabled

In this way, the output of the PWM will always be either the old waveform or the new waveform, not some variation in between. If the channel is not enabled, then writes to the period register will go directly to the latches as well as the buffer.

NOTE: *Reads of this register return the most recent value written. Reads do not necessarily return the value of the currently active period due to the double buffering scheme.*

Reference [PWM Period and Duty](#) for more information.

To calculate the output period, take the selected clock source period for the channel of interest (A, B, SA, or SB) and multiply it by the value in the period register for that channel:

- Left Aligned Output (CAEx=0)

$$\text{PWMx Period} = \text{Channel Clock Period} * \text{PWMPERx}$$
- Center Aligned Output (CAEx=1)

$$\text{PWMx Period} = \text{Channel Clock Period} * (2 * \text{PWMPERx})$$

For Boundary Case programming values, please refer to [PWM Boundary Cases](#).



Freescale Semiconductor, Inc.

Pulse Width Modulator (PWM) Register Descriptions

	Bit 7	6	5	4	3	2	1	Bit 0
Address	\$0014							PWMPER0
Read:	Bit 7	6	5	4	3	2	1	Bit 0
Write:	Bit 7	6	5	4	3	2	1	Bit 0
Reset:	1	1	1	1	1	1	1	1
Address	\$0015							PWMPER1
Read:	Bit 7	6	5	4	3	2	1	Bit 0
Write:	Bit 7	6	5	4	3	2	1	Bit 0
Reset:	1	1	1	1	1	1	1	1
Address	\$0016							PWMPER2
Read:	Bit 7	6	5	4	3	2	1	Bit 0
Write:	Bit 7	6	5	4	3	2	1	Bit 0
Reset:	1	1	1	1	1	1	1	1
Address	\$0017							PWMPER3
Read:	Bit 7	6	5	4	3	2	1	Bit 0
Write:	Bit 7	6	5	4	3	2	1	Bit 0
Reset:	1	1	1	1	1	1	1	1
Address	\$0018							PWMPER4
Read:	Bit 7	6	5	4	3	2	1	Bit 0
Write:	Bit 7	6	5	4	3	2	1	Bit 0
Reset:	1	1	1	1	1	1	1	1
Address	\$0019							PWMPER5
Read:	Bit 7	6	5	4	3	2	1	Bit 0
Write:	Bit 7	6	5	4	3	2	1	Bit 0
Reset:	1	1	1	1	1	1	1	1
Address	\$001A							PWMPER6
Read:	Bit 7	6	5	4	3	2	1	Bit 0
Write:	Bit 7	6	5	4	3	2	1	Bit 0
Reset:	1	1	1	1	1	1	1	1
Address	\$001B							PWMPER7
Read:	Bit 7	6	5	4	3	2	1	Bit 0
Write:	Bit 7	6	5	4	3	2	1	Bit 0
Reset:	1	1	1	1	1	1	1	1

Read: anytime

Write: anytime

Pulse Width Modulator (PWM)
**PWM Channel
Duty Registers
(PWMDTYx)**

There is a dedicated duty register for each channel. The value in this register determines the duty of the associated PWM channel. The duty value is compared to the counter and if it is equal to the counter value a match occurs and the output changes state.

The duty registers for each channel are double buffered so that if they change while the channel is enabled, the change will NOT take effect until one of the following occurs:

- The effective period ends
- The counter is written (counter resets to \$00)
- The channel is disabled

In this way, the output of the PWM will always be either the old duty waveform or the new duty waveform, not some variation in between. If the channel is not enabled, then writes to the duty register will go directly to the latches as well as the buffer.

NOTE: Reads of this register return the most recent value written. Reads do not necessarily return the value of the currently active duty due to the double buffering scheme.

Reference [PWM Period and Duty](#) for more information.

NOTE: Depending on the polarity bit, the duty registers will contain the count of either the high time or the low time. If the polarity bit is one, the output starts high and then goes low when the duty count is reached, so the duty registers contain a count of the high time. If the polarity bit is zero, the output starts low and then goes high when the duty count is reached, so the duty registers contain a count of the low time.

To calculate the output duty cycle (high time as a % of period) for a particular channel:

- Polarity = 0 (PPOLx=0)
Duty Cycle = $[(PWMPERx - PWMDTYx) / PWMPERx] * 100\%$
- Polarity = 1 (PPOLx=1)
Duty Cycle = $[PWMDTYx / PWMPERx] * 100\%$

For Boundary Case programming values, please refer to [PWM Boundary Cases](#).

	Bit 7	6	5	4	3	2	1	Bit 0
Address	\$001C							PWMDTY0
Read:	Bit 7	6	5	4	3	2	1	Bit 0
Write:								
Reset:	1	1	1	1	1	1	1	1
Address	\$001D							PWMDTY1
Read:	Bit 7	6	5	4	3	2	1	Bit 0
Write:								
Reset:	1	1	1	1	1	1	1	1
Address	\$001E							PWMDTY2
Read:	Bit 7	6	5	4	3	2	1	Bit 0
Write:								
Reset:	1	1	1	1	1	1	1	1
Address	\$001F							PWMDTY3
Read:	Bit 7	6	5	4	3	2	1	Bit 0
Write:								
Reset:	1	1	1	1	1	1	1	1
Address	\$0020							PWMDTY4
Read:	Bit 7	6	5	4	3	2	1	Bit 0
Write:								
Reset:	1	1	1	1	1	1	1	1
Address	\$0021							PWMDTY5
Read:	Bit 7	6	5	4	3	2	1	Bit 0
Write:								
Reset:	1	1	1	1	1	1	1	1
Address	\$0022							PWMDTY6
Read:	Bit 7	6	5	4	3	2	1	Bit 0
Write:								
Reset:	1	1	1	1	1	1	1	1
Address	\$0023							PWMDTY7
Read:	Bit 7	6	5	4	3	2	1	Bit 0
Write:								
Reset:	1	1	1	1	1	1	1	1

Read: anytime

Write: anytime

Pulse Width Modulator (PWM)

PWM Shutdown Register (PWMSDN)

Address Offset: \$0024

	Bit 7	6	5	4	3	2	1	Bit 0
Read:	PWMIF	PWMIE	0	PWMLVL	0	PWM7IN	PWM7INL	PWM7ENA
Write:			PWMRSTRT					
Reset:	0	0	0	0	0	0	0	0

 = Reserved or unimplemented

The PWMSDN register provides for the shutdown functionality of the PWM module in the emergency cases.

Read: anytime

Write: anytime

PWM7ENA — PWM emergency shutdown Enable

If this bit is '1' the pin associated with channel 7 is forced to input and the emergency shutdown feature is enabled. All the other bits in this register are meaningful only if PWM7ENA = 1.

- 1 = PWM emergency feature is enabled.
- 0 = PWM emergency feature disabled.

PWM7INL — PWM shutdown active input level for ch. 7.

If the emergency shutdown feature is enabled (PWM7ENA = 1), this bit determines the active level of the PWM7 channel.

- 1 = Active level is high
- 0 = Active level is low

PWM7IN — PWM channel 7 input status.

This reflects the current status of the PWM7 pin.

PWMLVL — PWM shutdown output Level.

If active level as defined by the PWM7IN input, gets asserted all enabled PWM channels are immediately driven to the level defined by PWMLVL.

- 1 = PWM outputs are forced to 1.
- 0 = PWM outputs are forced to 0

PWMRSTRT — PWM Restart.

The PWM can only be restarted if the PWM channel input is de-asserted. After writing a '1' to the PWMRSTRT bit (trigger event) the PWM channels start running after the corresponding counter passes next 'counter == 0' phase.

Also if the PWM7ENA bit is reset to 0, the PWM do not start before the counter passes \$00.

The bit is always read as '0'.

PWMIE — PWM Interrupt Enable

If interrupt is enabled an interrupt to the CPU is asserted.

1 = PWM interrupt is enabled.

0 = PWM interrupt is disabled.

PWMIF — PWM Interrupt Flag

Any change from passive to asserted (active) state or from active to passive state will be flagged by setting the PWMIF flag = 1. The flag is cleared by writing a '1' to it. Writing a '0' has no effect.

1 = change on PWM7IN input

0 = No change on PWM7IN input.

Reserved Registers

– PWM Reserved

Memory Space

Address Offset: \$0025, \$0026, \$0027

	Bit 7	6	5	4	3	2	1	Bit 0
Read:	0	0	0	0	0	0	0	0
Write:								
Reset:	0	0	0	0	0	0	0	0

= Reserved or unimplemented

The following registers are reserved for PWM future expansion. Reading any one of these locations returns \$00. Writing any one of these locations has no effect.

Read: will always read \$00

Write: unimplemented

Functional Description

PWM Clock Select There are four available clocks called clock A, clock B, clock SA (Scaled A), and clock SB (Scaled B). These four clocks are based on the clock, E Clock which runs at the same frequency as the IP bus clock *ipg_clock*.

NOTE: *All E Clock (E) references within this document are used to refer only to the frequency and do not suggest that this clock is actually used in implementation.*

For the MC9S12DP256, E clock is same as the ipg_clk. So all reference to E clock in this document are to be read as ipg_clk.

Clock A and B can be software selected to be E, E/2, E/4, E/8,..., E/64, E/128. Clock SA uses clock A as an input and divides it further with a reloadable counter. Similarly, Clock SB uses clock B as an input and divides it further with a reloadable counter. The rates available for clock SA are software selectable to be clock A divided by 2, 4, 6, 8, ..., or 512 in increments of divide by 2. Similar rates are available for clock SB. Each PWM channel has the capability of selecting one of two clocks, either the pre-scaled clock (clock A or B) or the scaled clock (clock SA or SB).

The block diagram in [Figure 46](#) shows the four different clocks and how the scaled clocks are created.

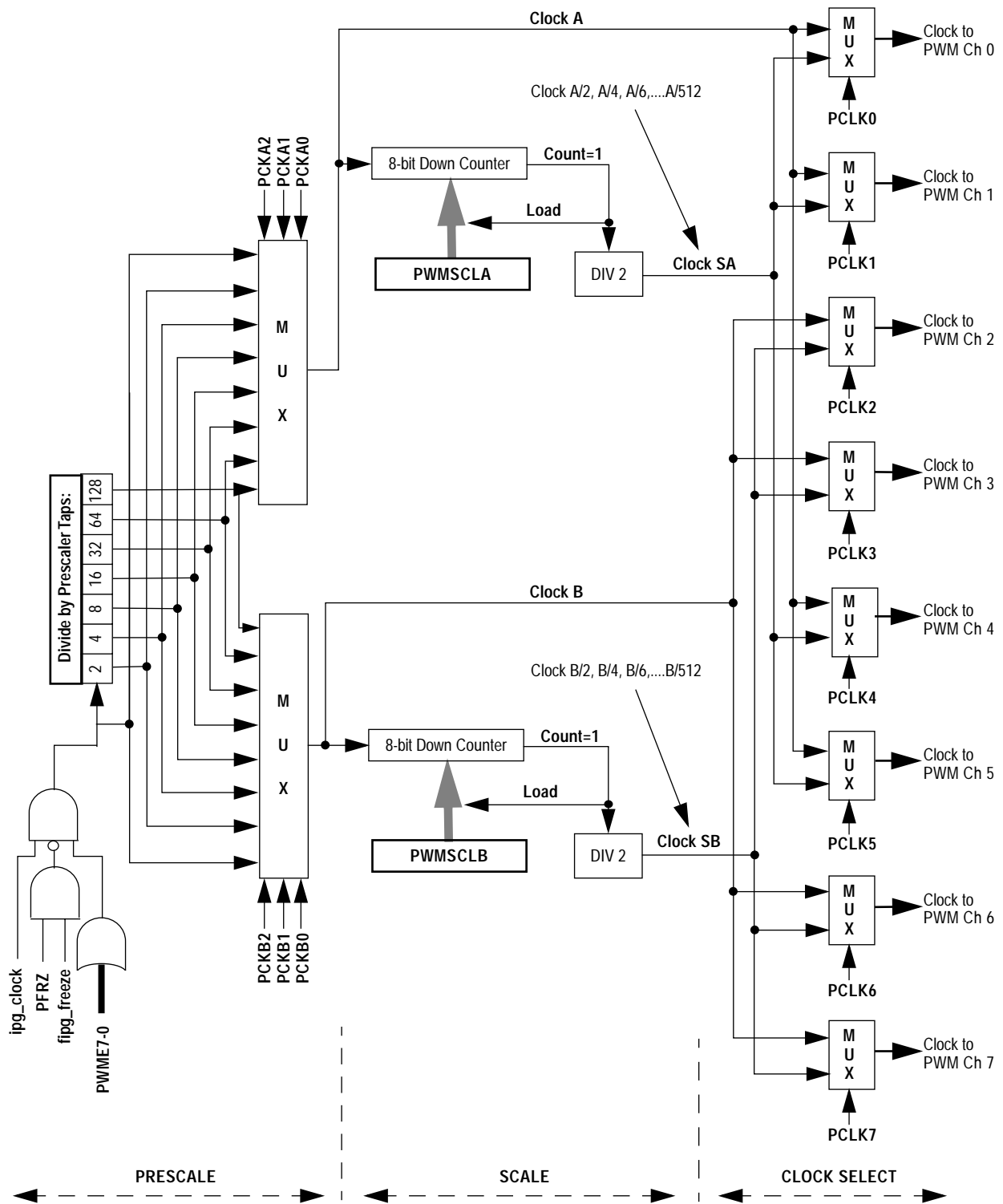

Figure 46 PWM Clock Select Block Diagram

Pulse Width Modulator (PWM)
Prescale

The input clock to the PWM prescaler is the bus clock. It can be disabled whenever the part is in freeze mode by setting the PFRZ bit in the PWMCTL register. If this bit is set, whenever the MCU is in freeze mode (ipg_freeze active) the input clock to the prescaler is disabled. This is useful for emulation in order to freeze the PWM. The input clock can also be disabled when all eight PWM channels are disabled (PWME7–0=0). This is useful for reducing power by disabling the prescale counter.

Clock A and clock B are scaled values of the input clock. The value is software selectable for both clock A and clock B and has options of E, E/2, E/4, E/8, E/16, E/32, E/64, or E/128. The value selected for clock A is determined by the PCKA2, PCKA1, PCKA0 bits in the PWMPRCLK register. The value selected for clock B is determined by the PCKB2, PCKB1, PCKB0 bits also in the PWMPRCLK register.

Clock Scale

The scaled A clock uses clock A as an input and divides it further with a user programmable value and then divides this by 2. The scaled B clock uses clock B as an input and divides it further with a user programmable value and then divides this by 2. The rates available for clock SA are software selectable to be clock A divided by 2, 4, 6, 8, ..., or 512 in increments of divide by 2. Similar rates are available for clock SB.

Clock A is used as an input to an 8-bit down counter. This down counter loads a user programmable scale value from the scale register (PWMSCLA). When the down counter reaches one, two things happen; a pulse is output and the 8-bit counter is re-loaded. The output signal from this circuit is further divided by two. This gives a greater range with only a slight reduction in granularity. Clock SA equals Clock A divided by two times the value in the PWMSCLA register.

NOTE: $Clock\ SA = Clock\ A / (2 * PWMSCLA)$

When PWMSCLA = \$00, PWMSCLA value is considered a full scale value of 256. Clock A is thus divided by 512.

Similarly, Clock B is used as an input to an 8-bit down counter followed by a divide by two producing clock SB. Thus, clock SB equals Clock B divided by two times the value in the PWMSCLB register.

NOTE: $Clock\ SB = Clock\ B / (2 * PWMSCLB)$

When PWMSCLB = \$00, PWMSCLB value is considered a full scale value of 256. Clock B is thus divided by 512.

As an example, consider the case in which the user writes \$FF into the PWMSCLA register. Clock A for this case will be E divided by 4. A pulse will occur at a rate of once every 255x4 E cycles. Passing this through the divide by two circuit produces a clock signal at an E divided by 2040 rate. Similarly, a value of \$01 in the PWMSCLA register when clock A is E divided by 4 will produce a clock at an E divided by 8 rate.

Writing to PWMSCLA or PWMSCLB causes the associated 8-bit down counter to be re-loaded. Otherwise, when changing rates the counter would have to count down to \$01 before counting at the proper rate. Forcing the associated counter to re-load the scale register value every time PWMSCLA or PWMSCLB is written prevents this.

CAUTION: *Writing to the scale registers while channels are operating can cause irregularities in the PWM outputs.*

Clock Select

Each PWM channel has the capability of selecting one of two clocks. For channels 0, 1, 4, and 5 the clock choices are clock A or clock SA. For channels 2, 3, 6, and 7 the choices are clock B or clock SB. The clock selection is done with the PCLKx control bits in the PWMCLK register.

CAUTION: *Changing clock control bits while channels are operating can cause irregularities in the PWM outputs.*

PWM Channel Timers

The main part of the PWM module are the actual timers. Each of the timer channels has a counter, a period register and a duty register (each are 8-bit). The waveform output period is controlled by a match between the period register and the value in the counter. The duty is controlled by a match between the duty register and the counter value and causes the state of the output to change during the period. The starting polarity of the output is also selectable on a per channel basis. Shown below in [Figure 47](#) is the block diagram for the PWM timer

Pulse Width Modulator (PWM)

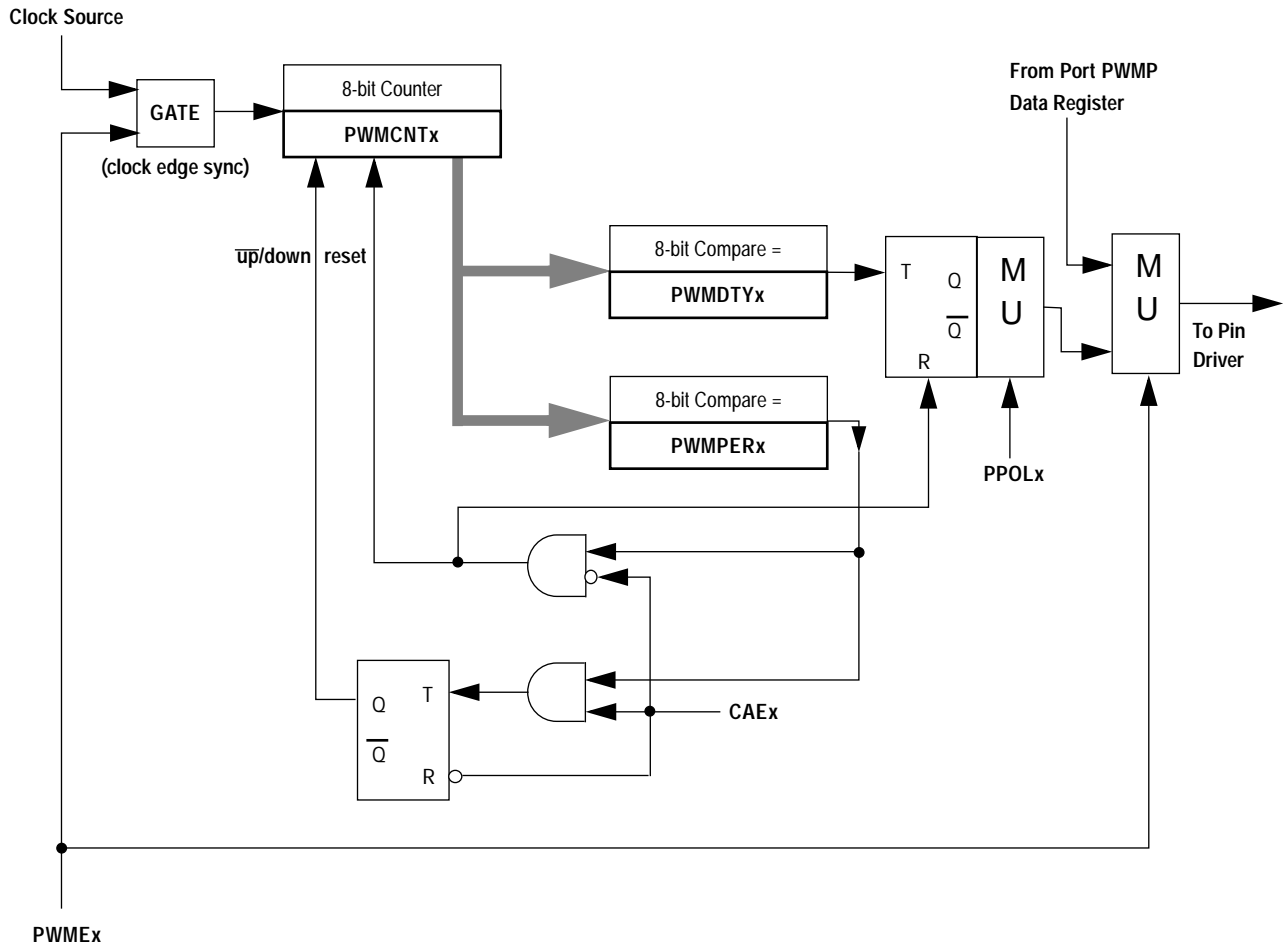

Figure 47 PWM Timer Channel Block Diagram

PWM Enable

Each PWM channel has an enable bit (PWME_x) to start its waveform output. When any of the PWME_x bits are set (PWME_x=1), the associated PWM output signal is enabled immediately. However, the actual PWM waveform is not available on the associated PWM output until its clock source begins its next cycle due to the synchronization of PWME_x and the clock source. An exception to this is when channels are concatenated. Refer to [PWM 16-Bit Functions](#) for more detail.

CAUTION: *The first PWM cycle after enabling the channel can be irregular.*

On the front end of the PWM timer, the clock is enabled to the PWM circuit by the PWME_x bit being high. There is an edge-synchronizing circuit to guarantee that the clock will only be enabled or disabled at an

edge. When the channel is disabled (PWME_x=0), the counter for the channel does not count.

PWM Polarity

Each channel has a polarity bit to allow starting a waveform cycle with a high or low signal. This is shown on the block diagram as a mux select of either the Q output or the \bar{Q} output of the PWM output flip flop. When one of the bits in the PWM_{POL} register is set, the associated PWM channel output is high at the beginning of the waveform, then goes low when the duty count is reached. Conversely, if the polarity bit is zero, the output starts low and then goes high when the duty count is reached.

PWM Period and Duty

Dedicated period and duty registers exist for each channel and are double buffered so that if they change while the channel is enabled, the change will NOT take effect until one of the following occurs:

- The effective period ends
- The counter is written (counter resets to \$00)
- The channel is disabled

In this way, the output of the PWM will always be either the old waveform or the new waveform, not some variation in between. If the channel is not enabled, then writes to the period and duty registers will go directly to the latches as well as the buffer.

A change in duty or period can be forced into effect 'immediately' by writing the new value to the duty and/or period registers and then writing to the counter. This forces the counter to reset and the new duty and/or period values to be latched. In addition, since the counter is readable it is possible to know where the count is with respect to the duty value and software can be used to make adjustments

CAUTION: *When forcing a new period or duty into effect immediately, an irregular PWM cycle can occur.*

NOTE: Depending on the polarity bit, the duty registers will contain the count of either the high time or the low time.

Pulse Width Modulator (PWM)

*PWM Timer
Counters*

Each channel has a dedicated 8-bit up/down counter which runs at the rate of the selected clock source (reference [PWM Clock Select](#) for the available clock sources and rates). The counter compares to two registers, a duty register and a period register as shown in [Figure 47](#). When the PWM counter matches the duty register the output flip-flop changes state causing the PWM waveform to also change state. A match between the PWM counter and the period register behaves differently depending on what output mode is selected as shown in [Figure 47](#) and described in [Left Aligned Outputs](#) and [Center Aligned Outputs](#).

Each channel counter can be read at anytime without affecting the count or the operation of the PWM channel.

Any value written to the counter causes the counter to reset to \$00, the counter direction to be set to up, the immediate load of both duty and period registers with values from the buffers, and the output to change according to the polarity bit. When the channel is disabled (PWME_x=0), the counter stops. When a channel becomes enabled (PWME_x=1), the associated PWM counter continues from the count in the PWMCNT_x register. This allows the waveform to continue where it left off when the channel is re-enabled. When the channel is disabled, writing '0' to the period register will cause the counter to reset on the next selected clock.

NOTE: *If the user wants to start a new 'clean' PWM waveform without any 'history' from the old waveform, the user must write to channel counter (PWMCNT_x) prior to enabling the PWM channel (PWME_x=1).*

Generally, writes to the counter are done prior to enabling a channel in order to start from a known state. However, writing a counter can also be done while the PWM channel is enabled (counting). The effect is similar to writing the counter when the channel is disabled except that the new period is started immediately with the output set according to the polarity bit.

CAUTION: *Writing to the counter while the channel is enabled can cause an irregular PWM cycle to occur.*

The counter is cleared at the end of the effective period (see [Left Aligned Outputs](#) and [Center Aligned Outputs](#) for more details).

Table 52 PWM Timer Counter Conditions

Counter Clears (\$00)	Counter Counts	Counter Stops
When PWMCNTx register written to any value	When PWM channel is enabled (PWME _x =1). Counts from last value in PWMCNT _x .	When PWM channel is disabled (PWME _x =0)
Effective period ends		

Left Aligned Outputs

The PWM timer provides the choice of two types of outputs, Left Aligned or Center Aligned outputs. They are selected with the CAEx bits in the PWMCAE register. If the CAEx bit is cleared (CAEx=0), the corresponding PWM output will be left aligned.

In left aligned output mode, the 8-bit counter is configured as an up counter only. It compares to two registers, a duty register and a period register as shown in the block diagram in [Figure 47](#). When the PWM counter matches the duty register the output flip-flop changes state causing the PWM waveform to also change state. A match between the PWM counter and the period register resets the counter and the output flip-flop as shown in [Figure 47](#) as well as performing a load from the double buffer period and duty register to the associated registers as described in [PWM Period and Duty](#). The counter counts from 0 to the value in the period register – 1.

NOTE: *Changing the PWM output mode from Left Aligned Output to Center Aligned Output (or vice versa) while channels are operating can cause irregularities in the PWM output. It is recommended to program the output mode before enabling the PWM channel.*

Pulse Width Modulator (PWM)

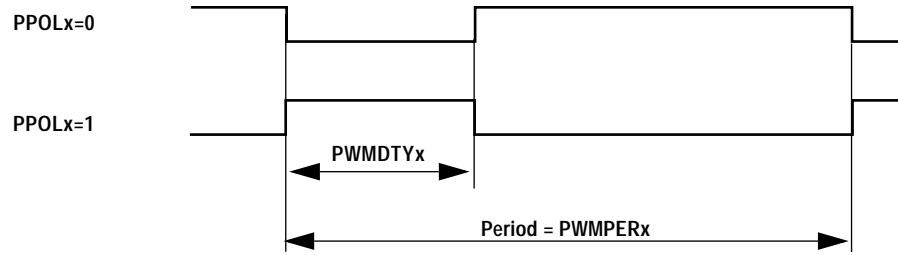

Figure 48 PWM Left Aligned Output Waveform

To calculate the output frequency in left aligned output mode for a particular channel, take the selected clock source frequency for the channel (A, B, SA, or SB) and divide it by the value in the period register for that channel.

- PWMx Frequency = Clock(A, B, SA, or SB) / PWMPERx
- PWMx Duty Cycle (high time as a % of period):
 - Polarity = 0 (PPOLx=0)
 Duty Cycle = [(PWMPERx-PWMDTYx)/PWMPERx] * 100%
 - Polarity = 1 (PPOLx=1)
 Duty Cycle = [PWMDTYx / PWMPERx] * 100%

As an example of a left aligned output, consider the following case:

Clock Source = E, where E=10MHz (100ns period)

PPOLx = 0

PWMPERx = 4

PWMDTYx = 1

PWMx Frequency = 10MHz/4 = 2.5MHz

PWMx Period = 400ns

PWMx Duty Cycle = 3/4 *100% = 75%

The output waveform generated is shown in [Figure 49](#).

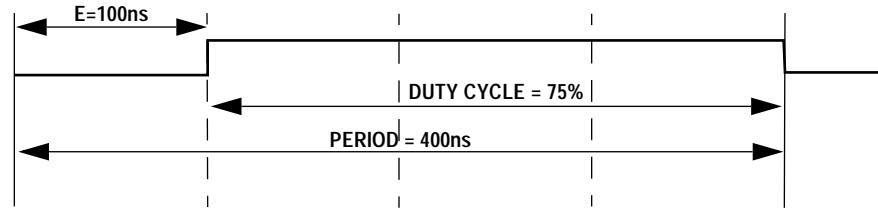

Figure 49 PWM Left Aligned Output Example Waveform

*Center Aligned
Outputs*

For Center Aligned Output Mode selection, set the CAEx bit (CAEx=1) in the PWMCAE register and the corresponding PWM output will be center aligned.

The 8-bit counter operates as an up/down counter in this mode and is set to up whenever the counter is equal to \$00. The counter compares to two registers, a duty register and a period register as shown in the block diagram in [Figure 47](#). When the PWM counter matches the duty register the output flip-flop changes state causing the PWM waveform to also change state. A match between the PWM counter and the period register changes the counter direction from an up-count to a down-count. When the PWM counter decrements and matches the duty register again, the output flip-flop changes state causing the PWM output to also change state. When the PWM counter decrements and reaches zero, the counter direction changes from a down-count back to an up-count and a load from the double buffer period and duty registers to the associated registers is performed as described in [PWM Period and Duty](#). The counter counts from 0 up to the value in the period register and then back down to 0. Thus the effective period is $PWMPERx2$.

NOTE: *Changing the PWM output mode from Left Aligned Output to Center Aligned Output (or vice versa) while channels are operating can cause irregularities in the PWM output. It is recommended to program the output mode before enabling the PWM channel.*

Pulse Width Modulator (PWM)

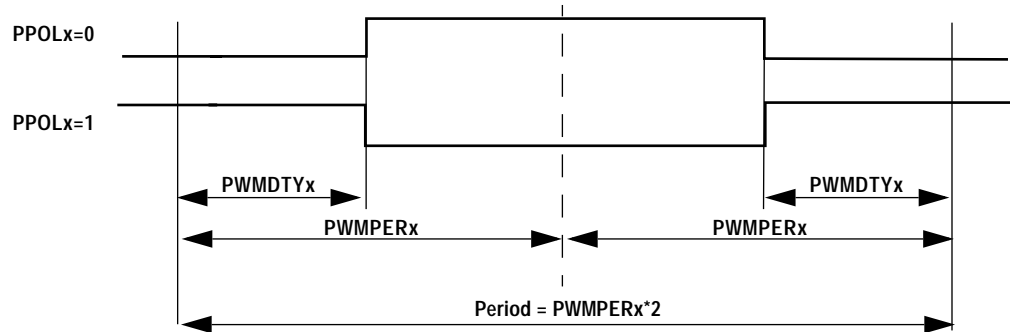

Figure 50 PWM Center Aligned Output Waveform

To calculate the output frequency in center aligned output mode for a particular channel, take the selected clock source frequency for the channel (A, B, SA, or SB) and divide it by twice the value in the period register for that channel.

- PWMx Frequency = Clock(A, B, SA, or SB) / (2*PWMPERx)
- PWMx Duty Cycle (high time as a % of period):
 - Polarity = 0 (PPOLx=0)
Duty Cycle = [(PWMPERx-PWMDTYx)/PWMPERx] * 100%
 - Polarity = 1 (PPOLx=1)
Duty Cycle = [PWMDTYx / PWMPERx] * 100%

As an example of a center aligned output, consider the following case:

Clock Source = E, where E=10MHz (100ns period)

PPOLx = 0

PWMPERx = 4

PWMDTYx = 1

PWMx Frequency = 10MHz/8 = 1.25MHz

PWMx Period = 800ns

PWMx Duty Cycle = 3/4 *100% = 75%

The output waveform generated is shown in [Figure 51](#)

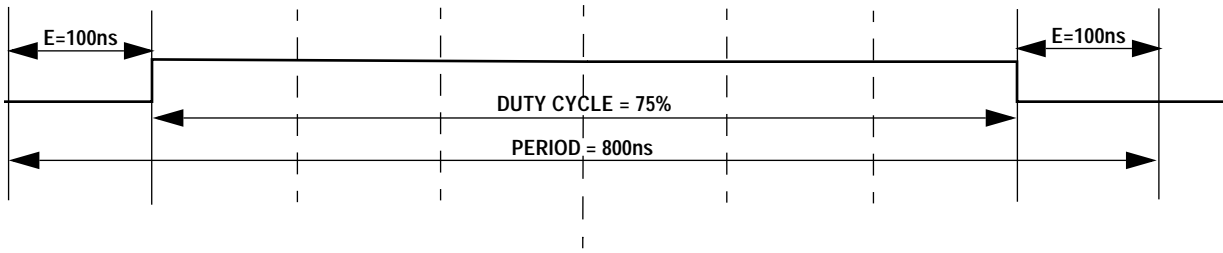

Figure 51 PWM Center Aligned Output Example Waveform

PWM 16-Bit Functions

The PWM timer also has the option of generating 8-channels of 8-bits or 4-channels of 16-bits for greater PWM resolution. This 16-bit channel option is achieved through the concatenation of two 8-bit channels.

The PWMCTL register contains four control bits, each of which is used to concatenate a pair of PWM channels into one 16-bit channel. Channels 6 and 7 are concatenated with the CON67 bit, channels 4 and 5 are concatenated with the CON45 bit, channels 2 and 3 are concatenated with the CON23 bit, and channels 0 and 1 are concatenated with the CON01 bit.

CAUTION: *Change these bits only when both corresponding channels are disabled.*

When channels 6 and 7 are concatenated, channel 6 registers become the high order bytes of the double byte channel as shown in [Figure 52](#). Similarly, when channels 4 and 5 are concatenated, channel 4 registers become the high order bytes of the double byte channel. When channels 2 and 3 are concatenated, channel 2 registers become the high order bytes of the double byte channel. When channels 0 and 1 are concatenated, channel 0 registers become the high order bytes of the double byte channel.

Pulse Width Modulator (PWM)

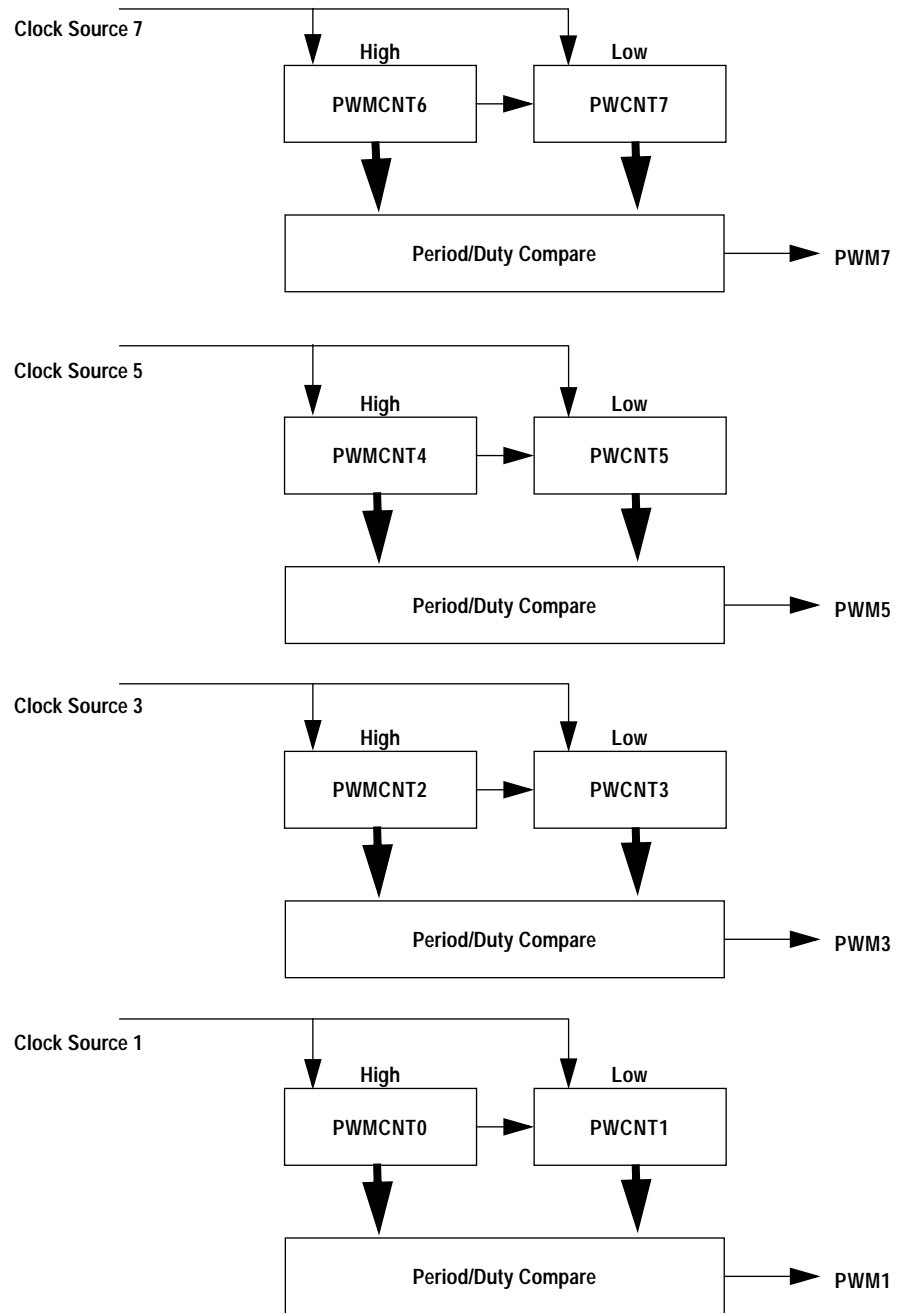

Figure 52 PWM 16-Bit Mode

When using the 16-bit concatenated mode, the clock source is determined by the low order 8-bit channel clock select control bits. That is channel 7 when channels 6 and 7 are concatenated, channel 5 when

channels 4 and 5 are concatenated, channel 3 when channels 2 and 3 are concatenated, and channel 1 when channels 0 and 1 are concatenated. The resulting PWM is output to the pins of the corresponding low order 8-bit channel as also shown in [Figure 52](#). The polarity of the resulting PWM output is controlled by the PPOLx bit of the corresponding low order 8-bit channel as well.

Once concatenated mode is enabled (CONxx bits set in PWMCTL register) then enabling/disabling the corresponding 16-bit PWM channel is controlled by the low order PWME_x bit. In this case, the high order bytes PWME_x bits have no effect and their corresponding PWM output is disabled.

In concatenated mode, writes to the 16-bit counter by using a 16-bit access or writes to either the low or high order byte of the counter will reset the 16-bit counter. Reads of the 16-bit counter must be made by 16-bit access to maintain data coherency.

Either left aligned or center aligned output mode can be used in concatenated mode and is controlled by the low order CAE_x bit. The high order CAE_x bit has no effect.

The table shown below is used to summarize which channels are used to set the various control bits when in 16-bit mode.

Table 53 16-bit Concatenation Mode Summary

CONxx	PWME _x	PPOL _x	PCLK _x	CAE _x	PWM _x OUTPUT
CON67	PWME7	PPOL7	PCLK7	CAE7	PWM7
CON45	PWME5	PPOL5	PCLK5	CAE5	PWM5
CON23	PWME3	PPOL3	PCLK3	CAE3	PWM3
CON01	PWME1	PPOL1	PCLK1	CAE1	PWM1

Pulse Width Modulator (PWM)
PWM Boundary Cases

The following table summarizes the boundary conditions for the PWM regardless of the output mode (Left Aligned or Center Aligned) and 8-bit (normal) or 16-bit (concatenation):

Table 54 PWM Boundary Cases

PWMDTYx	PWMPERx	PPOLx	PWMx Output
\$00 (indicates no duty)	>\$00	1	Always Low
\$00 (indicates no duty)	>\$00	0	Always High
XX	\$00 ⁽¹⁾ (indicates no period)	1	Always High
XX	\$00 ¹ (indicates no period)	0	Always Low
>= PWMPERx	XX	1	Always High
>= PWMPERx	XX	0	Always Low

1. Counter=\$00 and does not count.

Reset Initialization

The reset state of each individual bit is listed within the Register Description section (see [Register Descriptions](#)) which details the registers and their bit-fields. All special functions or modes which are initialized during or just following reset are described within this section.

- The 8-bit up/down counter is configured as an up counter out of reset.
- All the channels are disabled and all the counters don't count.

Modes of Operation

Normal Modes The PWM module behaves as described within this specification in all normal modes.

Special Modes The PWM module behaves as described within this specification in all special modes.

WARNING: *While in special modes, do not access registers \$0006, \$0007, \$000A and \$000B. Writing to any of these registers can alter the PWM functionality.*

Emulation Modes In Freeze Mode, there is an option to disable the input clock to the prescaler by setting the PFRZ bit in the PWMCTL register. If this bit is set, whenever the MCU is in freeze mode the input clock to the prescaler is disabled. This feature is useful during emulation as it allows the PWM function to be suspended. In this way, the counters of the PWM can be stopped while in freeze mode so that once normal program flow is continued, the counters are re-enabled to simulate real-time operations. Since the registers can still be accessed in this mode, to re-enable the prescaler clock, either disable the PFRZ bit or exit freeze mode.

Security Modes The PWM module has no security features.

Pulse Width Modulator (PWM)

Low Power Options

This section summarizes the low power options available in the PWM module. Low power design practices are implemented where possible.

The IP bus module clock (ipb_clk) is used for the programming model register writes. This clock is active only when module_en is asserted.

Run Mode

While in run mode, if all eight PWM channels are disabled (PWME7–0=0), the prescaler counter shuts off for power savings (see [Figure 46](#)).

Wait Mode

The PWM will keep running in WAIT unless the PSWAI bit in the PWMCTL register is enabled. This allows for lower power consumption in WAIT mode by disabling the input clock to the prescaler. When in WAIT mode with this bit set, no activity in the PWM occurs and the PWM outputs go to a static state (high or low).

Stop Mode

In STOP mode, the PWM module is stopped since all the clocks from IP bus to the module are stopped. The PWM outputs go to a static state (high or low).

Interrupt Operation

The PWM module has only one interrupt which is generated at the time of emergency shutdown, if the corresponding enable bit (PWMIE in the PWMSDN register) is set.

Enhanced Capture Timer (ECT)

Contents

Overview	341
Features	342
Modes of Operation	342
Abbreviations	342
Block Diagram	344
Signal Descriptions	350
Module Memory Map	351
Register Quick Reference	354
Register Descriptions	356
Modes of Operation	383
Interrupts	386
Description of Interrupt Operation	387

Overview

The HC12 Enhanced Capture Timer module has the features of the HC12 Standard Timer module enhanced by additional features in order to enlarge the field of applications, in particular for automotive ABS applications.

The basic timer consists of a 16-bit, software-programmable counter driven by a prescaler. This timer can be used for many purposes, including input waveform measurements while simultaneously generating an output waveform. Pulse widths can vary from microseconds to many seconds.

A full access for the counter registers or the input capture/output compare registers should take place in one clock cycle. Accessing high

Enhanced Capture Timer (ECT)

byte and low byte separately for all of these registers may not yield the same result as accessing them in one word.

Features

- 16-Bit Buffer Register for four Input Capture (IC) channels.
- Four 8-Bit Pulse Accumulators with 8-bit buffer registers associated with the four buffered IC channels. Configurable also as two 16-Bit Pulse Accumulators.
- 16-Bit Modulus Down-Counter with 4-bit Prescaler.
- Four user selectable Delay Counters for input noise immunity increase.
- Support for only 16-bit access on the IP bus.

Modes of Operation

- STOP: Timer and modulus counter are off since clocks are stopped.
- FREEZE: Timer and modulus counter keep on running, unless TSFRZ in TSCR(\$06) is set to one.
- WAIT: Counters keep on running, unless TSWAI in TSCR (\$06) is set to one.
- NORMAL: Timer and modulus counter keep on running, unless TEN in TSCR(\$06) respectively MCEN in MCCTL (\$26) are cleared.

Abbreviations

Following abbreviations are used in the document.

M clock – Module clock (clk of IPbus)



PACLK – 16-bit pulse accumulator A (PACA) clock

Enhanced Capture Timer (ECT)

Block Diagram

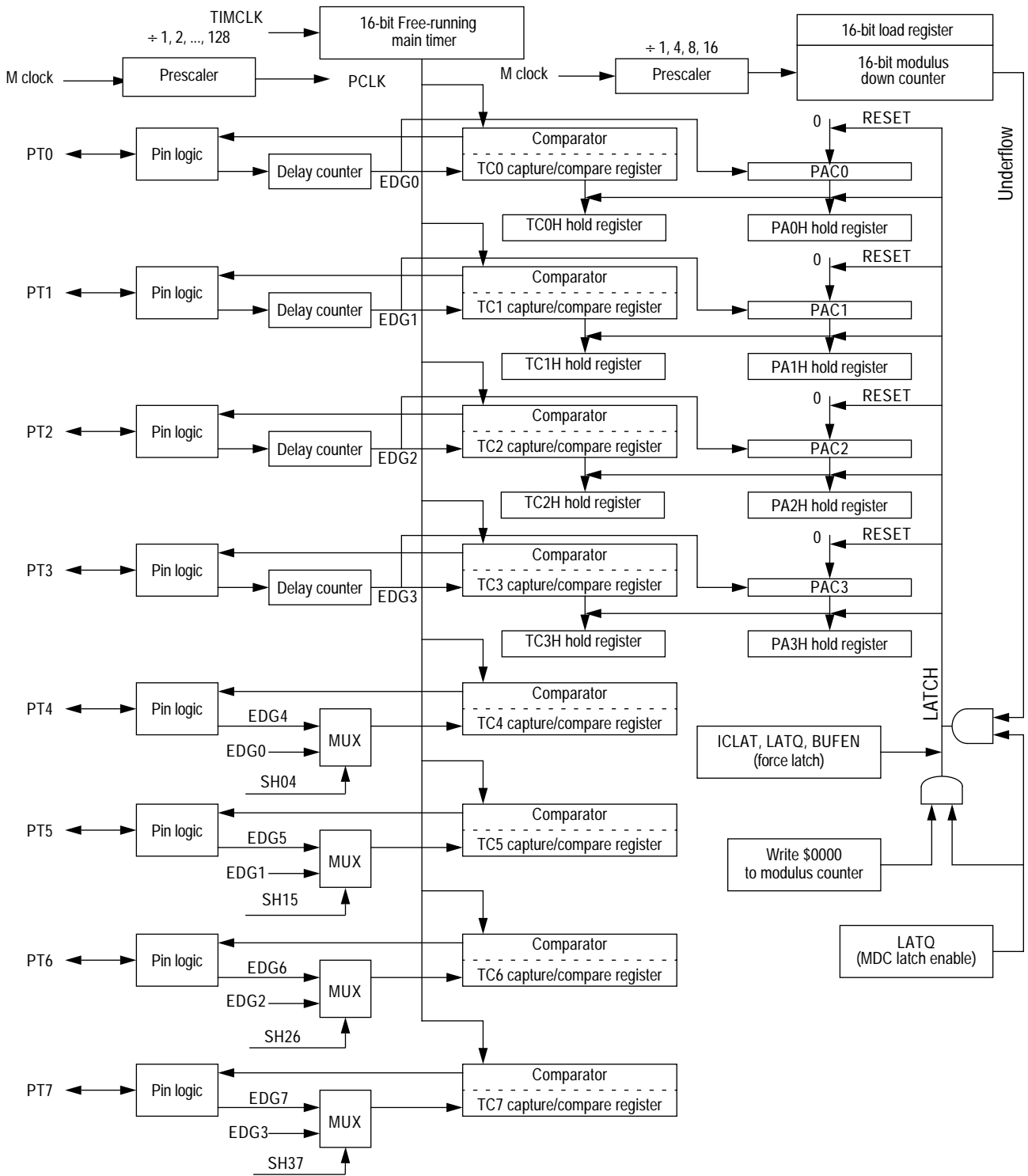

Figure 53 Timer Block Diagram in Latch Mode

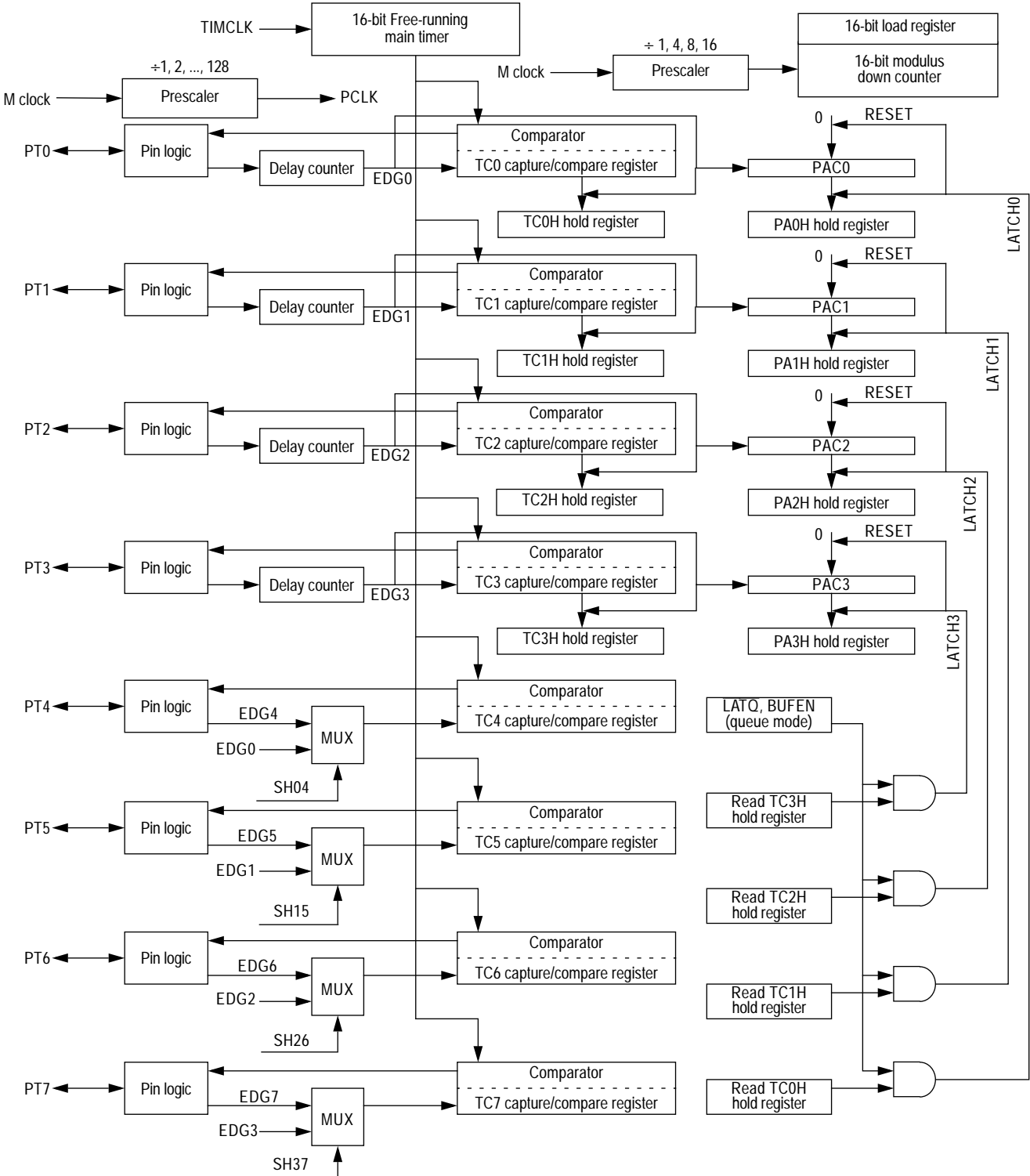

Figure 54 Timer Block Diagram in Queue Mode

Enhanced Capture Timer (ECT)

Freescale Semiconductor, Inc.

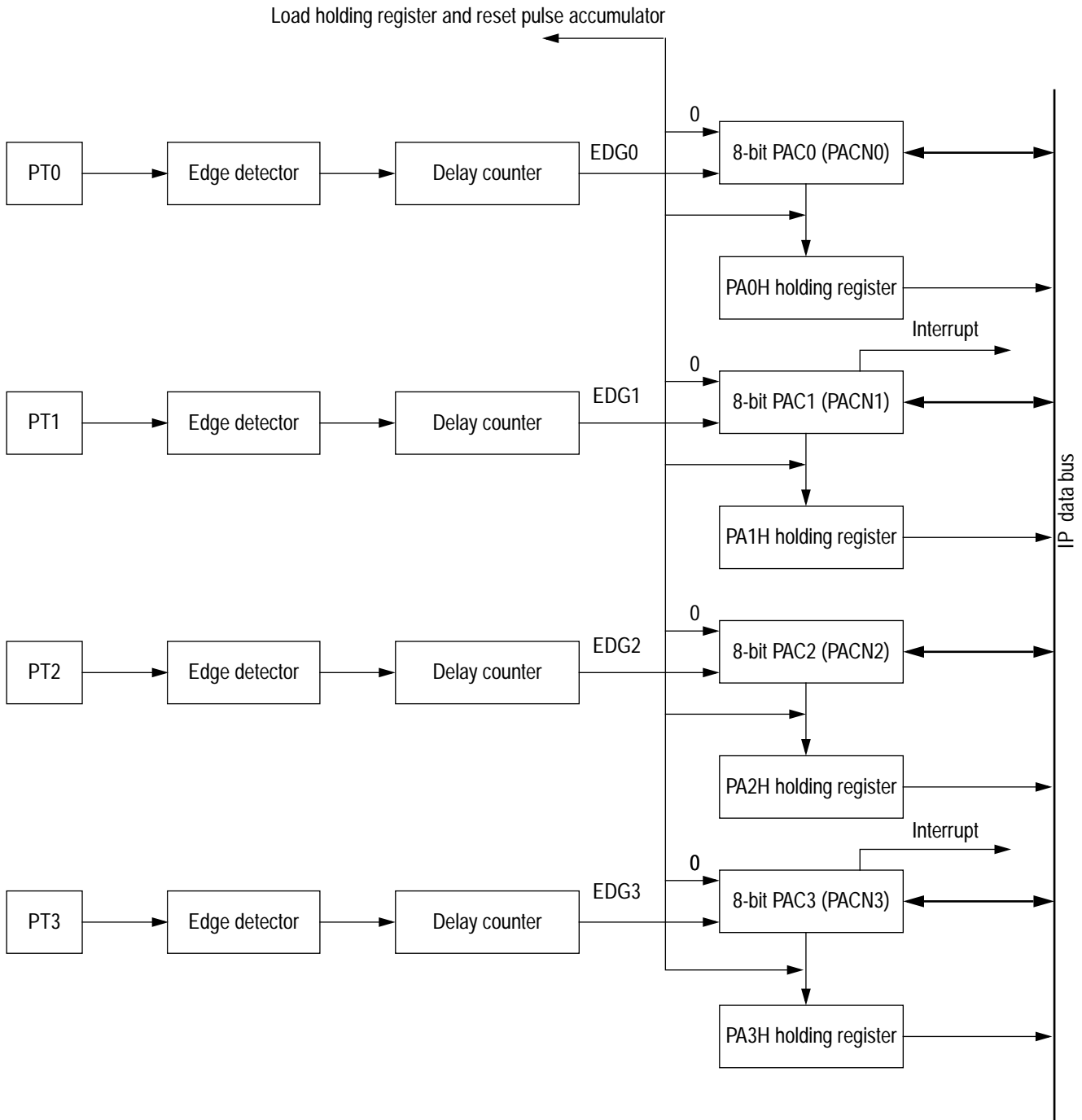

Figure 55 8-Bit Pulse Accumulators Block Diagram

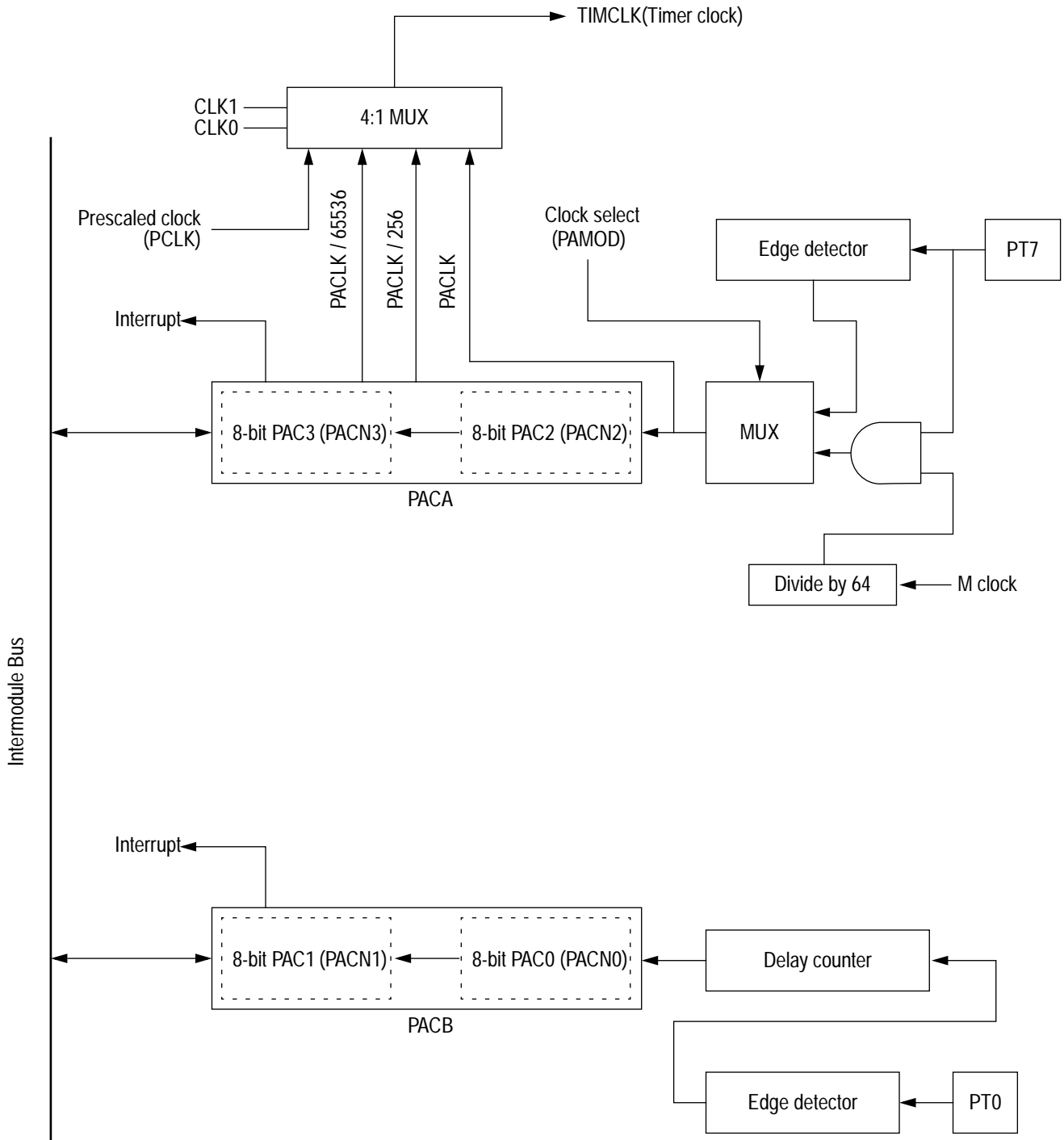

Figure 56 16-Bit Pulse Accumulators Block Diagram

Enhanced Capture Timer (ECT)

Freescale Semiconductor, Inc.

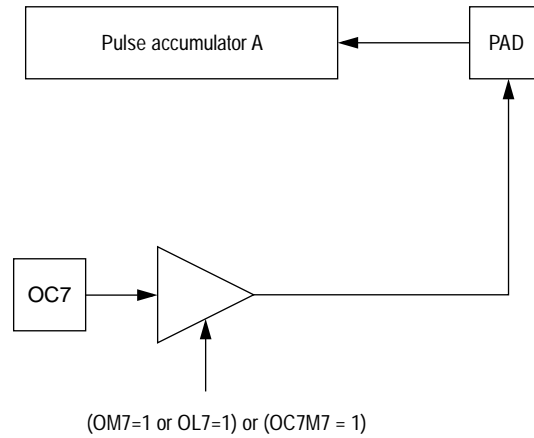

Figure 57 Block Diagram for Port7 with Output compare/Pulse Accumulator A

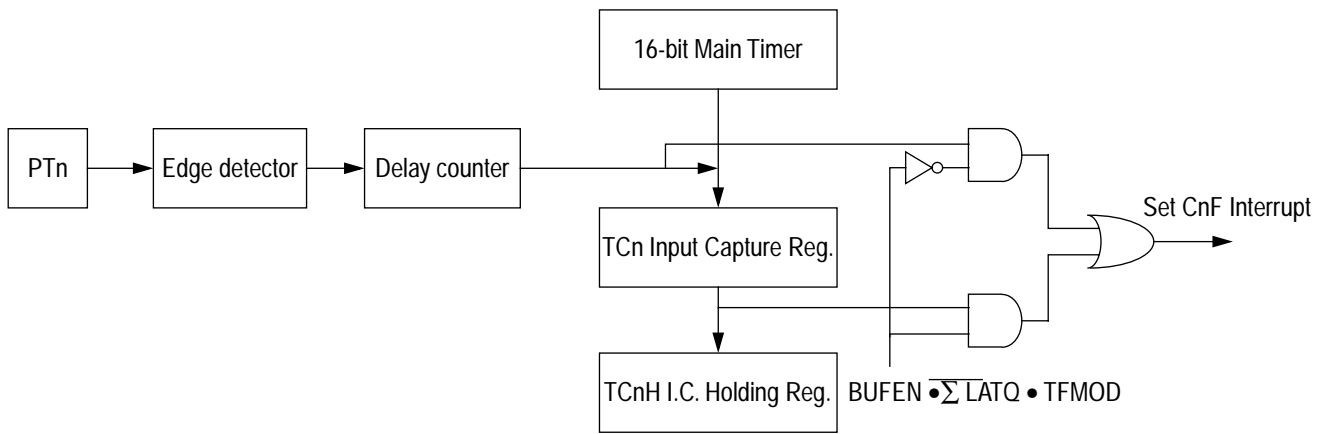

Figure 58 Interrupt Flag Setting

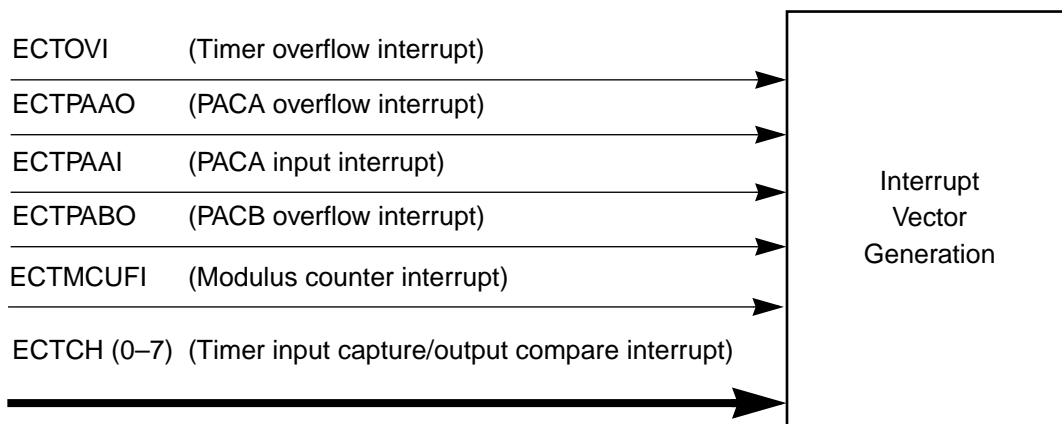

Figure 59 Interrupt Enable Bits

Enhanced Capture Timer (ECT)

Signal Descriptions

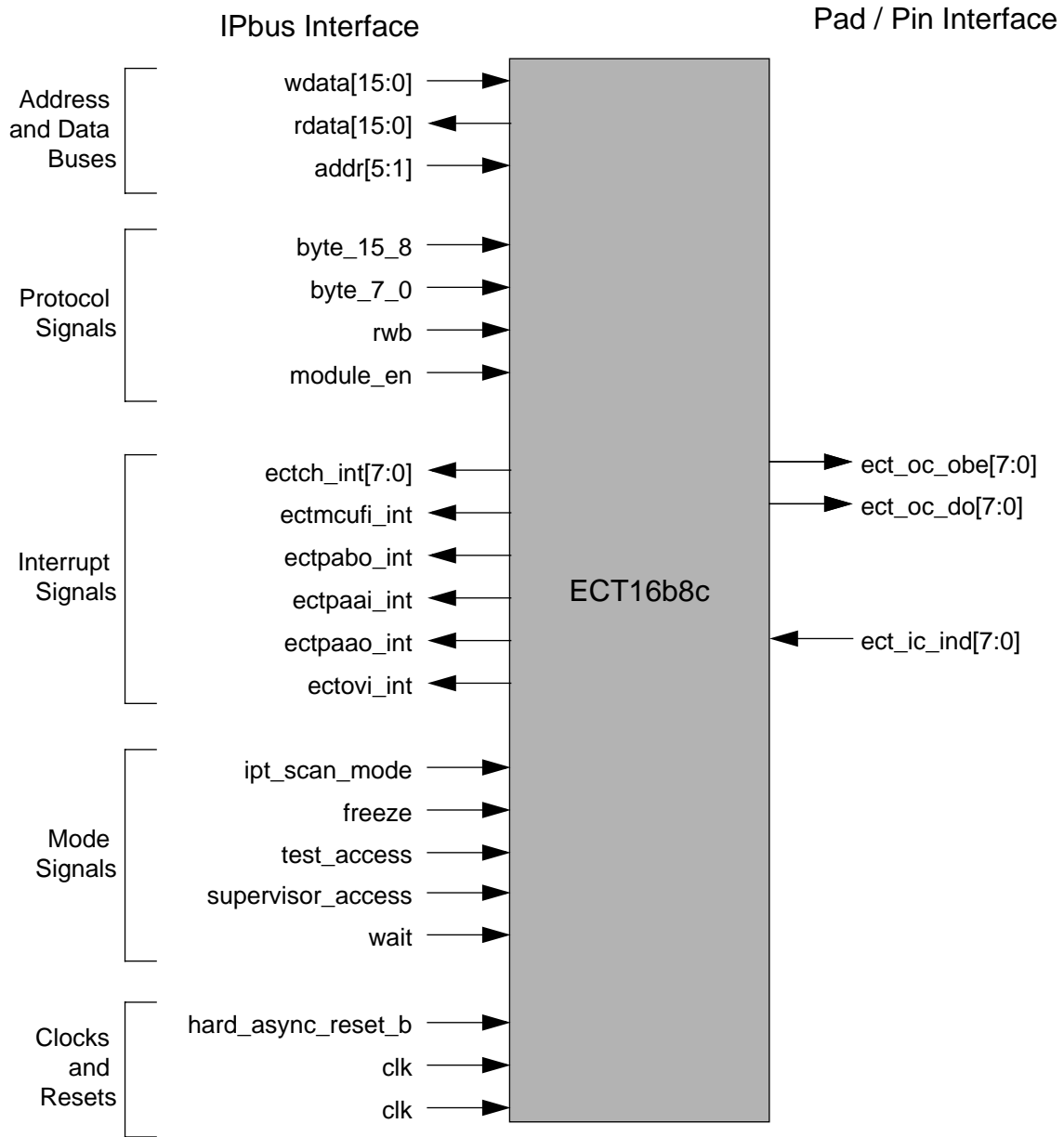

Figure 60 ECT16b8c Block Interface

Module Specific Signals

Figure 61 summarizes the ect_16b8c signal characteristics.

Figure 61 ECT16b8c Signal Characteristics

Signal Name	Mnemonic	Input/Output	Active State	Reset State	Function
Pad Input Signals					
Timer Input Data	ect_ic_ind[7:0]	Input	—	—	Input digital from buffer to module
Pad Control Signals					
Output buffer enable	ect_oc_obe[7:0]	Output	High	8'h00	When asserted the pad output is driven by the timer outputs
Output Signals					
Timer Output Data	ect_oc_do[7:0]	Output	—	—	Output data from the module to the pads

ect_oc_obe[7:0] These signals are the output buffer enable. When asserted, then pad is driven by the timer outputs. When negated the timer outputs do not drive the pad.

ect_oc_do[7:0] These signals are the output data from the module to the pads.

ect_ic_ind[7:0] Input digital from input buffer to module.

Module Memory Map

The memory map for the ECT module is given below in [Table 55](#). The Address listed for each register is the address offset. The total address for each register is the sum of the base address for the ECT module and the address offset for each register.

Enhanced Capture Timer (ECT)
Table 55 Module Memory Map

Offset	Use	Access
\$_00	Timer Input Capture/Output Compare Select (TIOS)	Read/Write
\$_01	Timer Compare Force Register (CFORC)	Read/Write ¹
\$_02	Output Compare 7 Mask Register (OC7M)	Read/Write
\$_03	Output Compare 7 Data Register (OC7D)	Read/Write
\$_04	Timer Count Register High (TCNT)	Read/Write ²
\$_05	Timer Count Register Low (TCNT)	Read/Write ²
\$_06	Timer System Control Register1 (TSCR1)	Read/Write
\$_07	Timer Toggle Overflow Register (TTOV)	Read/Write
\$_08	Timer Control Register1 (TCTL1)	Read/Write
\$_09	Timer Control Register2 (TCTL2)	Read/Write
\$_0A	Timer Control Register3 (TCTL3)	Read/Write
\$_0B	Timer Control Register4 (TCTL4)	Read/Write
\$_0C	Timer Interrupt Enable Register (TIE)	Read/Write
\$_0D	Timer System Control Register2 (TSCR2)	Read/Write
\$_0E	Main Timer Interrupt Flag1 (TFLG1)	Read/Write
\$_0F	Main Timer Interrupt Flag2 (TFLG2)	Read/Write
\$_10	Timer Input Capture/Output Compare Register0 High (TC0)	Read/Write ³
\$_11	Timer Input Capture/Output Compare Register0 Low (TC0)	Read/Write ³
\$_12	Timer Input Capture/Output Compare Register1 High (TC1)	Read/Write ³
\$_13	Timer Input Capture/Output Compare Register1 Low (TC1)	Read/Write ³
\$_14	Timer Input Capture/Output Compare Register2 High (TC2)	Read/Write ³
\$_15	Timer Input Capture/Output Compare Register2 Low (TC2)	Read/Write ³
\$_16	Timer Input Capture/Output Compare Register3 High (TC3)	Read/Write ³
\$_17	Timer Input Capture/Output Compare Register3 Low (TC3)	Read/Write ³
\$_18	Timer Input Capture/Output Compare Register4 High (TC4)	Read/Write ³
\$_19	Timer Input Capture/Output Compare Register4 Low (TC4)	Read/Write ³
\$_1A	Timer Input Capture/Output Compare Register5 High (TC5)	Read/Write ³
\$_1B	Timer Input Capture/Output Compare Register5 Low (TC5)	Read/Write ³
\$_1C	Timer Input Capture/Output Compare Register6 High (TC6)	Read/Write ³
\$_1D	Timer Input Capture/Output Compare Register6 Low (TC6)	Read/Write ³
\$_1E	Timer Input Capture/Output Compare Register7 High (TC7)	Read/Write ³
\$_1F	Timer Input Capture/Output Compare Register7 Low (TC7)	Read/Write ³
\$_20	16-Bit Pulse Accumulator A Control Register (PACTL)	Read/Write
\$_21	Pulse Accumulator A Flag Register (PAFLG)	Read/Write

Table 55 Module Memory Map

\$_22	Pulse Accumulator Count Register3 (PACN3)	Read/Write
\$0023	Pulse Accumulator Count Register2 (PACN2)	Read/Write
\$0024	Pulse Accumulator Count Register1 (PACN1)	Read/Write
\$0025	Pulse Accumulator Count Register0 (PACN0)	Read/Write
\$0026	16-Bit Modulus Down Counter Register (MCCTL)	Read/Write
\$0027	16-Bit Modulus Down Counter Flag Register (MCFLG)	Read/Write
\$0028	Input Control Pulse Accumulator Register (ICPAR)	Read/Write
\$0029	Delay Counter Control Register (DLYCT)	Read/Write
\$002A	Input Control Overwrite Register (ICOVW)	Read/Write
\$002B	Input Control System Control Register (ICSYS)	Read/Write ⁴
\$002C	Reserved	–
\$002D	Timer Test Register (TIMTST)	Read/Write ²
\$002E	Reserved	–
\$002F	Reserved	–
\$0030	16-Bit Pulse Accumulator B Control Register (PBCTL)	Read/Write
\$0031	16-Bit Pulse Accumulator B Flag Register (PBFLG)	Read/Write
\$0032	8-Bit Pulse Accumulator Holding Register3 (PA3H)	Read/Write ⁵
\$0033	8-Bit Pulse Accumulator Holding Register2 (PA2H)	Read/Write ⁵
\$0034	8-Bit Pulse Accumulator Holding Register1 (PA1H)	Read/Write ⁵
\$0035	8-Bit Pulse Accumulator Holding Register0 (PA0H)	Read/Write ⁵
\$0036	Modulus Down-Counter Count Register High (MCCNT)	Read/Write
\$0037	Modulus Down-Counter Count Register Low (MCCNT)	Read/Write
\$0038	Timer Input Capture Holding Register0 High (TC0H)	Read/Write ⁵
\$0039	Timer Input Capture Holding Register0 Low (TC0H)	Read/Write ⁵
\$003A	Timer Input Capture Holding Register1 High (TC1H)	Read/Write ⁵
\$003B	Timer Input Capture Holding Register1 Low (TC1H)	Read/Write ⁵
\$003C	Timer Input Capture Holding Register2 High (TC2H)	Read/Write ⁵
\$003D	Timer Input Capture Holding Register2 Low (TC2H)	Read/Write ⁵
\$003E	Timer Input Capture Holding Register3 High (TC3H)	Read/Write ⁵
\$003F	Timer Input Capture Holding Register3 Low (TC3H)	Read/Write ⁵

NOTE:

1. Always read \$00.
2. Only writable in special modes (test_mode = 1).
3. Write to these registers have no meaning or effect during input capture.
4. May be written once (test_mode = 0) but writes are always permitted when test_mode = 0
5. Write has no effect.



Enhanced Capture Timer (ECT)

Register Quick Reference

	Bit 7	6	5	4	3	2	1	Bit 0	
\$0000	IOS7	IOS6	IOS5	IOS4	IOS3	IOS2	IOS1	IOS0	TIOS
\$0001	FOC7	FOC6	FOC5	FOC4	FOC3	FOC2	FOC1	FOC0	CFORC
\$0002	OC7M7	OC7M6	OC7M5	OC7M4	OC7M3	OC7M2	OC7M1	OC7M0	OC7M
\$0003	OC7D7	OC7D6	OC7D5	OC7D4	OC7D3	OC7D2	OC7D1	OC7D0	OC7D
\$0004	Bit 15	14	13	12	11	10	9	Bit 8	TCNT(hi)
\$0005	Bit 7	6	5	4	3	2	1	Bit 0	TCNT(lo)
\$0006	TEN	TSWAI	TSFRZ	TFFCA	3	2	1	Bit 0	TSCR1
\$0007	TOV7	TOV6	TOV5	TOV4	TOV3	TOV2	TOV1	TOV0	TTOV
\$0008	OM7	OL7	OM6	OL6	OM5	OL5	OM4	OL4	TCTL1
\$0009	OM3	OL3	OM2	OL2	OM1	OL1	OM0	OL0	TCTL2
\$000A	EDG7B	EDG7A	EDG6B	EDG6A	EDG5B	EDG5A	EDG4B	EDG4A	TCTL3
\$000B	EDG3B	EDG3A	EDG2B	EDG2A	EDG1B	EDG1A	EDG0B	EDG0A	TCTL4
\$000C	C7I	C6I	C5I	C4I	C3I	C2I	C1I	C0I	TIE
\$000D	TOI	0	0	0	TCRE	PR2	PR1	PR0	TSCR2
\$000E	C7F	C6F	C5F	C4F	C3F	C2F	C1F	C0F	TFLG1
\$000F	TOF	0	0	0	0	0	0	0	TFLG2
\$0010	Bit 15	14	13	12	11	10	9	Bit 8	TC0(hi)
\$0011	Bit 7	6	5	4	3	2	1	Bit 0	TC0(lo)
\$0012	Bit 15	14	13	12	11	10	9	Bit 8	TC1(hi)
\$0013	Bit 7	6	5	4	3	2	1	Bit 0	TC1(lo)
\$0014	Bit 15	14	13	12	11	10	9	Bit 8	TC2(hi)
\$0015	Bit 7	6	5	4	3	2	1	Bit 0	TC2(lo)
\$0016	Bit 15	14	13	12	11	10	9	Bit 8	TC3(hi)
\$0017	Bit 7	6	5	4	3	2	1	Bit 0	TC3(lo)
\$0018	Bit 15	14	13	12	11	10	9	Bit 8	TC4(hi)
\$0019	Bit 7	6	5	4	3	2	1	Bit 0	TC4(lo)
\$001A	Bit 15	14	13	12	11	10	9	Bit 8	TC5(hi)
\$001B	Bit 7	6	5	4	3	2	1	Bit 0	TC5(lo)
\$001C	Bit 15	14	13	12	11	10	9	Bit 8	TC6(hi)
\$001D	Bit 7	6	5	4	3	2	1	Bit 0	TC6(lo)
\$001E	Bit 15	14	13	12	11	10	9	Bit 8	TC7(hi)
\$001F	Bit 7	6	5	4	3	2	1	Bit 0	TC7(lo)

	Bit 7	6	5	4	3	2	1	Bit 0	
\$0020	0	PAEN	PAMOD	PEDGE	CLK1	CLK0	PAOVI	PAI	PACTL
\$0021	0	0	0	0	0	0	PAOVF	PAIF	PAFLG
\$0022	Bit 7	6	5	4	3	2	1	Bit 0	PACN3(hi)
\$0023	Bit 7	6	5	4	3	2	1	Bit 0	PACN2(lo)
\$0024	Bit 7	6	5	4	3	2	1	Bit 0	PACN1(hi)
\$0025	Bit 7	6	5	4	3	2	1	Bit 0	PACN0(lo)
\$0026	MCZI	MODMC	RDMCL	ICLAT	FLMC	MCEN	MCPR1	MCPR0	MCCTL
\$0027	MCZF	0	0	0	POLF3	POLF2	POLF1	POLF0	MCFLG
\$0028	0	0	0	0	PA3EN	PA2EN	PA1EN	PA0EN	ICPAR
\$0029	0	0	0	0	0	0	DLY1	DLY0	DLYCT
\$002A	NOVW7	NOVW6	NOVW5	NOVW4	NOVW3	NOVW2	NOVW1	NOVW0	ICOVW
\$002B	SH37	SH26	SH15	SH04	TFMOD	PACMX	BUFEN	LATQ	ICSYS
\$002C	0	0	0	0	0	0	0	0	Reserved
\$002D	0	0	0	0	0	0	TCBYP	0	TIMTST
\$002E	0	0	0	0	0	0	0	0	Reserved
\$002F	0	0	0	0	0	0	0	0	Reserved
\$0030	0	PBEN	0	0	0	0	PBOVI	0	PBCTL
\$0031	0	0	0	0	0	0	PBOVF	0	PBFLG
\$0032	Bit 7	6	5	4	3	2	1	Bit 0	PA3H
\$0033	Bit 7	6	5	4	3	2	1	Bit 0	PA2H
\$0034	Bit 7	6	5	4	3	2	1	Bit 0	PA1H
\$0035	Bit 7	6	5	4	3	2	1	Bit 0	PA0H
\$0036	Bit 15	14	13	12	11	10	9	Bit 8	MCCNT(hi)
\$0037	Bit 7	6	5	4	3	2	1	Bit 0	MCCNT(lo)
\$0038	Bit 15	14	13	12	11	10	9	Bit 8	TC0H(hi)
\$0039	Bit 7	6	5	4	3	2	1	Bit 0	TC0H(lo)
\$003A	Bit 15	14	13	12	11	10	9	Bit 8	TC1H(hi)
\$003B	Bit 7	6	5	4	3	2	1	Bit 0	TC1H(lo)
\$003C	Bit 15	14	13	12	11	10	9	Bit 8	TC2H(hi)
\$003D	Bit 7	6	5	4	3	2	1	Bit 0	TC2H(lo)
\$003E	Bit 15	14	13	12	11	10	9	Bit 8	TC3H(hi)
\$003F	Bit 7	6	5	4	3	2	1	Bit 0	TC3H(lo)

Figure 62 ECT Register Quick Reference

Enhanced Capture Timer (ECT)

Register Descriptions

This section consists of register descriptions in address order. Each description includes a standard register diagram with an associated figure number. Details of register bit and field function follow the register diagrams, in bit order.

**Timer Input
Capture/Output
Compare Select
(TIOS)**

Register offset: \$0000

	Bit 7	6	5	4	3	2	1	Bit 0
	IOS7	IOS6	IOS5	IOS4	IOS3	IOS2	IOS1	IOS0
RESET:	0	0	0	0	0	0	0	0

Read or write anytime.

IOS[7:0] — Input Capture or Output Compare Channel Configuration
 1 = The corresponding channel acts as an output compare.
 0 = The corresponding channel acts as an input capture

**Timer Compare
Force Register
(CFORC)**

Register offset: \$0001

	Bit 7	6	5	4	3	2	1	Bit 0
	FOC7	FOC6	FOC5	FOC4	FOC3	FOC2	FOC1	FOC0
RESET:	0	0	0	0	0	0	0	0

Read anytime but will always return \$00 (1 state is transient). Write anytime.

FOC[7:0] — Force Output Compare Action for Channel 7–0

A write to this register with the corresponding data bit(s) set causes the action which is programmed for output compare ‘n’ to occur

immediately. The action taken is the same as if a successful comparison had just taken place with the TCn register except the interrupt flag does not get set

NOTE: *A successful channel 7 output compare overrides any channel 6:0 compares. If forced output compare on any channel occurs at the same time as the successful output compare then forced output compare action will take precedence and interrupt flag won't get set.*

**Output Compare 7
Mask Register
(OC7M)**

Register offset: \$0002

	Bit 7	6	5	4	3	2	1	Bit 0
	OC7M7	OC7M6	OC7M5	OC7M4	OC7M3	OC7M2	OC7M1	OC7M0
RESET:	0	0	0	0	0	0	0	0

Read or write anytime.

Setting the OC7Mn (n ranges from 0 to 6) will set the corresponding port to be an output port when the corresponding TIOSn (n ranges from 0 to 6) bit is set to be an output compare.

NOTE: *A successful channel 7 output compare overrides any channel 6:0 compares. For each OC7M bit that is set, the output compare action reflects the corresponding OC7D bit.*

Enhanced Capture Timer (ECT)

**Output Compare 7
Data Register
(OC7D)**

Register offset: \$0003

	Bit 7	6	5	4	3	2	1	Bit 0
	OC7D7	OC7D6	OC7D5	OC7D4	OC7D3	OC7D2	OC7D1	OC7D0
RESET:	0	0	0	0	0	0	0	0

Read or write anytime.

A channel 7 output compare can cause bits in the output compare 7 data register to transfer to the timer port data register depending on the output compare 7 mask register.

**Timer Count
Register (TCNT)**

Register offset: \$0004–\$0005

	Bit 15	14	13	12	11	10	9	Bit 8
	Bit 7	6	5	4	3	2	1	Bit 0
RESET:	0	0	0	0	0	0	0	0

The 16-bit main timer is an up counter.

A full access for the counter register should take place in one clock cycle. A separate read/write for high byte and low byte will give a different result than accessing them as a word.

Read anytime.

Write has no meaning or effect in the normal mode; only writable in special modes (test_mode = 1).

The period of the first count after a write to the TCNT registers may be a different size because the write is not synchronized with the prescaler clock.

**Timer System
Control Register 1
(TSCR1)**

Register offset: \$0006

	Bit 7	6	5	4	3	2	1	Bit 0
	TEN	TSWAI	TSFRZ	TFFCA				
RESET:	0	0	0	0	0	0	0	0

Read or write anytime.

TEN — Timer Enable

- 1 = Allows the timer to function normally.
- 0 = Disables the main timer, including the counter. Can be used for reducing power consumption.

If for any reason the timer is not active, there is no ÷64 clock for the pulse accumulator since the ÷64 is generated by the timer prescaler.

TSWAI — Timer Module Stops While in Wait

- 1 = Disables the timer module when the MCU is in the wait mode. Timer interrupts cannot be used to get the MCU out of wait.
- 0 = Allows the timer module to continue running during wait.

TSWAI also affects pulse accumulators and modulus down counters.

TSFRZ — Timer and Modulus Counter Stop While in Freeze Mode

- 1 = Disables the timer and modulus counter whenever the MCU is in freeze mode. This is useful for emulation.
- 0 = Allows the timer and modulus counter to continue running while in freeze mode.

TSFRZ does not stop the pulse accumulator.

Enhanced Capture Timer (ECT)

TFFCA — Timer Fast Flag Clear All

1 = For TFLG1(\$0E), a read from an input capture or a write to the output compare channel (\$10–\$1F) causes the corresponding channel flag, CnF, to be cleared. For TFLG2 (\$0F), any access to the TCNT register (\$04, \$05) clears the TOF flag. Any access to the PACN3 and PACN2 registers (\$22, \$23) clears the PAOVF and PAIF flags in the PAFLG register (\$21). Any access to the PACN1 and PACN0 registers (\$24, \$25) clears the PBOVF flag in the PBFLG register (\$31). This has the advantage of eliminating software overhead in a separate clear sequence. Extra care is required to avoid accidental flag clearing due to unintended accesses.

0 = Allows the timer flag clearing to function normally.

Timer Toggle On Overflow Register 1 (TOV)

Register offset: \$0007

	Bit 7	6	5	4	3	2	1	0
	TOV7	TOV6	TOV5	TOV4	TOV3	TOV2	TOV1	TOV0
RESET	0	0	0	0	0	0	0	0

Read or write anytime.

TOVx — Toggle On Overflow Bits

TOVx toggles output compare pin on overflow. This feature only takes effect when in output compare mode. When set, it takes precedence over forced output compare but not channel 7 override events.

1 = Toggle output compare pin on overflow feature enabled

0 = Toggle output compare pin on overflow feature disabled

**Timer Control
Registers 1 and 2
(TCTL1, TCTL2)**

Register offset: \$0008

	Bit 7	6	5	4	3	2	1	Bit 0
TCTL1	OM7	OL7	OM6	OL6	OM5	OL5	OM4	OL4
RESET	0	0	0	0	0	0	0	0

Register offset: \$0009

	Bit 7	6	5	4	3	2	1	0
TCTL2	OM3	OL3	OM2	OL2	OM1	OL1	OM0	OL0
RESET	0	0	0	0	0	0	0	0

Read or write anytime.

OMn — Output Mode

OLn — Output Level

These eight pairs of control bits are encoded to specify the output action to be taken as a result of a successful OCn compare. When either OMn or OLn is one, the pin associated with OCn becomes an output tied to OCn.

NOTE: *To enable output action by OMn and OLn bits on timer port, the corresponding bit in OC7M should be cleared.*

Table 56 Compare Result Output Action

OMn	OLn	Action
0	0	Timer disconnected from output pin logic
0	1	Toggle OCn output line
1	0	Clear OCn output line to zero
1	1	Set OCn output line to one

To operate the 16-bit pulse accumulators A and B (PACA and PACB) independently of input capture or output compare 7 and 0 respectively the user must set the corresponding bits IOSn = 1, OMn = 0 and OLn = 0. OC7M7 or OC7M0 in the OC7M register must also be cleared.

Enhanced Capture Timer (ECT)

**Timer Control
Registers 3 and 4
(TCTL3, TCTL4)**

Register offset: \$000A

	Bit 7	6	5	4	3	2	1	Bit 0
TCTL3	EDG7B	EDG7A	EDG6B	EDG6A	EDG5B	EDG5A	EDG4B	EDG4A
RESET:	0	0	0	0	0	0	0	0

Register offset: \$000B

	Bit 7	6	5	4	3	2	1	Bit 0
TCTL4	EDG3B	EDG3A	EDG2B	EDG2A	EDG1B	EDG1A	EDG0B	EDG0A
RESET:	0	0	0	0	0	0	0	0

Read or write anytime.

EDGnB, EDGnA — Input Capture Edge Control

These eight pairs of control bits configure the input capture edge detector circuits.

The four pairs of control bits of TCTL4 also configure the 8 bit pulse accumulators PAC0–3.

For 16-bit pulse accumulator PACB, EDGE0B & EDGE0A, control bits of TCTL4 will decide the active edge.

Table 57 Edge Detector Circuit Configuration

EDGnB	EDGnA	Configuration
0	0	Capture disabled
0	1	Capture on rising edges only
1	0	Capture on falling edges only
1	1	Capture on any edge (rising or falling)

**Timer Interrupt
Enable Register
(TIE)**

Register offset: \$000C

	Bit 7	6	5	4	3	2	1	Bit 0
	C7I	C6I	C5I	C4I	C3I	C2I	C1I	C0I
RESET:	0	0	0	0	0	0	0	0

Read or write anytime.

The bits in TIE correspond bit-for-bit with the bits in the TFLG1 status register. If cleared, the corresponding flag is disabled from causing a hardware interrupt. If set, the corresponding flag is enabled to cause a interrupt.

C7I–C0I — Input Capture/Output Compare “x” Interrupt Enable

**Timer System
Control Register 2
(TSCR2)**

Register offset: \$000D

	Bit 7	6	5	4	3	2	1	Bit 0
	TOI	0	0	0	TCRE	PR2	PR1	PR0
RESET:	0	0	0	0	0	0	0	0

Read or write anytime.

TOI — Timer Overflow Interrupt Enable

- 1 = Hardware interrupt requested when TOF flag set
- 0 = Interrupt inhibited

TCRE — Timer Counter Reset Enable

This bit allows the timer counter to be reset by a successful output compare 7 event. This mode of operation is similar to an up-counting modulus counter.

- 1 = Counter reset by a successful output compare 7
- 0 = Counter reset inhibited and counter free runs

Enhanced Capture Timer (ECT)

If TC7 = \$0000 and TCRE = 1, TCNT will stay at \$0000 continuously.
 If TC7 = \$FFFF and TCRE = 1, TOF will never be set when TCNT is reset from \$FFFF to \$0000.

PR2, PR1, PR0 — Timer Prescaler Select

These three bits specify the number of ÷2 stages that are to be inserted between the module clock and the main timer counter.

Table 58 Prescaler Selection

PR2	PR1	PR0	Prescale Factor
0	0	0	1
0	0	1	2
0	1	0	4
0	1	1	8
1	0	0	16
1	0	1	32
1	1	0	64
1	1	1	128

The newly selected prescale factor will not take effect until the next synchronized edge where all prescale counter stages equal zero.

**Main Timer
 Interrupt Flag 1
 (TFLG1)**

Register offset: \$000E

	Bit 7	6	5	4	3	2	1	Bit 0
	C7F	C6F	C5F	C4F	C3F	C2F	C1F	C0F
RESET:	0	0	0	0	0	0	0	0

TFLG1 indicates when interrupt conditions have occurred. To clear a bit in the flag register, write a one to the bit.

Use of the TFMOD bit in the ICSYS register (\$2B) in conjunction with the use of the ICOVW register (\$2A) allows a timer interrupt to be generated after capturing two values in the capture and holding registers instead of generating an interrupt for every capture.

Read anytime. Write used in the clearing mechanism (set bits cause corresponding bits to be cleared). Writing a zero will not affect current status of the bit.

When TFFCA bit in TSCR register is set, a read from an input capture or a write into an output compare channel (\$10–\$1F) will cause the corresponding channel flag CnF to be cleared.

C7F–C0F — Input Capture/Output Compare Channel ‘n’ Flag.

C0F can also be set by 16-bit Pulse Accumulator B (PACB).

C3F–C0F can also be set by 8-bit pulse accumulators PAC3–PAC0.

**Main Timer
Interrupt Flag 2
(TFLG2)**

Register offset: \$000F

	Bit 7	6	5	4	3	2	1	Bit 0
TOF	0	0	0	0	0	0	0	0
RESET:	0	0	0	0	0	0	0	0

TFLG2 indicates when interrupt conditions have occurred. To clear a bit in the flag register, write the bit to one.

Read anytime. Write used in clearing mechanism (set bits cause corresponding bits to be cleared).

Any access to TCNT will clear TFLG2 register if the TFFCA bit in TSCR register is set.

TOF — Timer Overflow Flag

Set when 16-bit free-running timer overflows from \$FFFF to \$0000. This bit is cleared automatically by a write to the TFLG2 register with bit 7 set. (See also TCRE control bit explanation.)

Enhanced Capture Timer (ECT)

**Timer Input
Capture/Output
Compare
Registers 0–7
(TC0–TC7)**

Register offset: \$0010–\$001F

TC0	Bit 15	14	13	12	11	10	9	Bit 8
	Bit 7	6	5	4	3	2	1	Bit 0
TC1	Bit 15	14	13	12	11	10	9	Bit 8
	Bit 7	6	5	4	3	2	1	Bit 0
TC2	Bit 15	14	13	12	11	10	9	Bit 8
	Bit 7	6	5	4	3	2	1	Bit 0
TC3	Bit 15	14	13	12	11	10	9	Bit 8
	Bit 7	6	5	4	3	2	1	Bit 0
TC4	Bit 15	14	13	12	11	10	9	Bit 8
	Bit 7	6	5	4	3	2	1	Bit 0
TC5	Bit 15	14	13	12	11	10	9	Bit 8
	Bit 7	6	5	4	3	2	1	Bit 0
TC6	Bit 15	14	13	12	11	10	9	Bit 8
	Bit 7	6	5	4	3	2	1	Bit 0
TC7	Bit 15	14	13	12	11	10	9	Bit 8
	Bit 7	6	5	4	3	2	1	Bit 0
RESET	0	0	0	0	0	0	0	0

Depending on the TIOS bit for the corresponding channel, these registers are used to latch the value of the free-running counter when a defined transition is sensed by the corresponding input capture edge detector or to trigger an output action for output compare.

Read anytime. Write anytime for output compare function. Writes to these registers have no meaning or effect during input capture. All timer input capture/output compare registers are reset to \$0000.

**16-Bit Pulse
Accumulator A
Control Register
(PACTL)**

Register offset: \$0020

	Bit 7	6	5	4	3	2	1	Bit 0
	0	PAEN	PAMOD	PEDGE	CLK1	CLK0	PAOVI	PAI
RESET:	0	0	0	0	0	0	0	0

16-Bit Pulse Accumulator A (PACA) is formed by cascading the 8-bit pulse accumulators PAC3 and PAC2.

When PAEN is set, the PACA is enabled. The PACA shares the input pin with IC7.

Read: any time

Write: any time

PAEN — Pulse Accumulator A System Enable

1 = Pulse Accumulator A system enabled. The two 8-bit pulse accumulators PAC3 and PAC2 are cascaded to form the PACA 16-bit pulse accumulator. When PACA is enabled, the PACN3 and PACN2 registers contents are respectively the high and low byte of the PACA.

PA3EN and PA2EN control bits in ICPAR (\$28) have no effect. Pulse Accumulator Input Edge Flag (PAIF) function is enabled.

0 = 16-Bit Pulse Accumulator A system disabled. 8-bit PAC3 and PAC2 can be enabled when their related enable bits in ICPAR (\$28) are set.

Pulse Accumulator Input Edge Flag (PAIF) function is disabled.

PAEN is independent from TEN. With timer disabled, the pulse accumulator can still function unless pulse accumulator is disabled.

Enhanced Capture Timer (ECT)

PAMOD — Pulse Accumulator Mode

This bit is active only when the Pulse Accumulator A is enabled (PAEN = 1).

- 1 = gated time accumulation mode
- 0 = event counter mode

PEDGE — Pulse Accumulator Edge Control

This bit is active only when the Pulse Accumulator A is enabled (PAEN = 1).

For PAMOD bit = 0 (event counter mode).

- 1 = rising edges on PT7 pin cause the count to be incremented
- 0 = falling edges on PT7 pin cause the count to be incremented

For PAMOD bit = 1 (gated time accumulation mode).

- 1 = PT7 input pin low enables M (module clock) divided by 64 clock to Pulse Accumulator and the trailing rising edge on PT7 sets the PAIF flag
- 0 = PT7 input pin high enables M (module clock) divided by 64 clock to Pulse Accumulator and the trailing falling edge on PT7 sets the PAIF flag.

Table 59 Pin Action

PAMOD	PEDGE	Pin Action
0	0	Falling edge
0	1	Rising edge
1	0	Div. by 64 clock enabled with pin high level
1	1	Div. by 64 clock enabled with pin low level

If the timer is not active (TEN = 0 in TSCR), there is no divide-by-64 since the ÷64 clock is generated by the timer prescaler.

CLK1, CLK0 — Clock Select Bits

Table 60 Clock Selection

CLK1	CLK0	Clock Source
0	0	Use timer prescaler clock as timer counter clock
0	1	Use PACLK as input to timer counter clock
1	0	Use PACLK/256 as timer counter clock frequency
1	1	Use PACLK/65536 as timer counter clock frequency

For the description of PACLK please refer to [Figure 56](#).

If the pulse accumulator is disabled (PAEN = 0), the prescaler clock from the timer is always used as an input clock to the timer counter. The change from one selected clock to the other happens immediately after these bits are written.

PAOVI — Pulse Accumulator A Overflow Interrupt enable

1 = interrupt requested if PAOVF is set

0 = interrupt inhibited

PAI — Pulse Accumulator Input Interrupt enable

1 = interrupt requested if PAIF is set

0 = interrupt inhibited

**Pulse
Accumulator A
Flag Register
(PAFLG)**

Register offset: \$0021

	Bit 7	6	5	4	3	2	1	Bit 0
	0	0	0	0	0	0	PAOVF	PAIF
RESET:	0	0	0	0	0	0	0	0

Read or write anytime. When the TFFCA bit in the TSCR register is set, any access to the PACNT register will clear all the flags in the PAFLG register.

PAOVF — Pulse Accumulator A Overflow Flag

Set when the 16-bit pulse accumulator A overflows from \$FFFF to \$0000, or when 8-bit pulse accumulator 3 (PAC3) overflows from \$FF to \$00.

When PACMX = 1, PAOVF bit can also be set if 8-bit pulse accumulator 3 (PAC3) reaches \$FF followed by an active edge on PT3.

This bit is cleared automatically by a write to the PAFLG register with bit 1 set.

Enhanced Capture Timer (ECT)

PAIF — Pulse Accumulator Input edge Flag

Set when the selected edge is detected at the PT7 input pin. In event mode the event edge triggers PAIF and in gated time accumulation mode the trailing edge of the gate signal at the PT7 input pin triggers PAIF.

This bit is cleared by a write to the PAFLG register with bit 0 set. Any access to the PACN3, PACN2 registers will clear all the flags in this register when TFFCA bit in register TSCR(\$06) is set.

Pulse Accumulators Count Registers (PACN3, PACN2)

Register offset: \$0022–\$0023

PACN3	Bit 7	6	5	4	3	2	1	Bit 0
PACN2	Bit 7	6	5	4	3	2	1	Bit 0
RESET:	0	0	0	0	0	0	0	0

Read or write any time.

The two 8-bit pulse accumulators PAC3 and PAC2 are cascaded to form the PACA 16-bit pulse accumulator. When PACA is enabled (PAEN=1 in PACTL, \$20) the PACN3 and PACN2 registers contents are respectively the high and low byte of the PACA.

When PACN3 overflows from \$FF to \$00, the Interrupt flag PAOVF in PAFLG (\$21) is set.

Full count register access should take place in one clock cycle. A separate read/write for high byte and low byte will give a different result than accessing them as a word.

**Pulse
Accumulators
Count Registers
(PACN1, PACN0)**

Register offset: \$0024–\$0025

PACN1	Bit 7	6	5	4	3	2	1	Bit 0
PACN0	Bit 7	6	5	4	3	2	1	Bit 0
RESET	0	0	0	0	0	0	0	0

Read or write any time.

The two 8-bit pulse accumulators PAC1 and PAC0 are cascaded to form the PACB 16-bit pulse accumulator. When PACB is enabled, (PBEN=1 in PBCTL, \$30) the PACN1 and PACN0 registers contents are respectively the high and low byte of the PACB.

When PACN1 overflows from \$FF to \$00, the Interrupt flag PBOVF in PBFLG (\$31) is set.

Full count register access should take place in one clock cycle. A separate read/write for high byte and low byte will give a different result than accessing them as a word.

**16–Bit Modulus
Down-Counter
Control Register
(MCCTL)**

Register offset: \$0026

	Bit 7	6	5	4	3	2	1	Bit 0
	MCZI	MODMC	RDMCL	ICLAT	FLMC	MCEN	MCPR1	MCPR0
RESET:	0	0	0	0	0	0	0	0

Read or write any time.

MCZI — Modulus Counter Underflow Interrupt Enable
 1 = Modulus counter interrupt is enabled.
 0 = Modulus counter interrupt is disabled.

Enhanced Capture Timer (ECT)

MODMC — Modulus Mode Enable

1 = Modulus mode is enabled. When the counter reaches \$0000, the counter is loaded with the latest value written to the modulus count register.

0 = The counter counts once from the value written to it and will stop at \$0000.

NOTE: *For proper operation, the MCEN bit should be cleared before modifying the MODMC bit in order to reset the modulus counter to \$FFFF.*

RDMCL — Read Modulus Down-Counter Load

1 = Reads of the modulus count register will return the contents of the load register.

0 = Reads of the modulus count register will return the present value of the count register.

ICLAT — Input Capture Force Latch Action

When input capture latch mode is enabled (LATQ and BUFEN bit in ICSYS (\$2B) are set, a write one to this bit immediately forces the contents of the input capture registers TC0 to TC3 and their corresponding 8-bit pulse accumulators to be latched into the associated holding registers. The pulse accumulators will be automatically cleared when the latch action occurs.

Writing zero to this bit has no effect. Read of this bit will return always zero.

FLMC — Force Load Register into the Modulus Counter Count Register

This bit is active only when the modulus down-counter is enabled (MCEN=1).

A write one into this bit loads the load register into the modulus counter count register. This also resets the modulus counter prescaler.

Write zero to this bit has no effect.

When MODMC=0, counter starts counting and stops at \$0000.

Read of this bit will return always zero.

MCEN — Modulus Down-Counter Enable

1 = Modulus counter is enabled.

0 = Modulus counter disabled.

When MCEN=0, the counter is preset to \$FFFF. This will prevent an early interrupt flag when the modulus down-counter is enabled.

MCPR1, MCPR0 — Modulus Counter Prescaler select

These two bits specify the division rate of the modulus counter prescaler.

The newly selected prescaler division rate will not be effective until a load of the load register into the modulus counter count register occurs.

Table 61 Modulus Counter Prescaler Select

MCPR1	MCPR0	Prescaler division rate
0	0	1
0	1	4
1	0	8
1	1	16

**16-Bit Modulus
Down-Counter
FLAG Register
(MCFLG)**

Register offset: \$0027

	Bit 7	6	5	4	3	2	1	Bit 0
	MCZF	0	0	0	POLF3	POLF2	POLF1	POLF0
RESET:	0	0	0	0	0	0	0	0

Read: any time
Write: Only for clearing bit 7

MCZF — Modulus Counter Underflow Flag

The flag is set when the modulus down-counter reaches \$0000.

A write one to this bit clears the flag. Write zero has no effect.

Any access to the MCCNT register will clear the MCZF flag in this register when TFFCA bit in register TSCR(\$06) is set.

POLF3–POLF0 — First Input Capture Polarity Status

This are read only bits. Write to these bits has no effect.

Enhanced Capture Timer (ECT)

Each status bit gives the polarity of the first edge which has caused an input capture to occur after capture latch has been read.

Each POLFx corresponds to a timer PORTx input.

1 = The first input capture has been caused by a rising edge.

0 = The first input capture has been caused by a falling edge.

Input Control Pulse Accumulators Register (ICPAR)

Register offset: \$0028

	Bit 7	6	5	4	3	2	1	Bit 0
	0	0	0	0	PA3EN	PA2EN	PA1EN	PA0EN
RESET	0	0	0	0	0	0	0	0

The 8-bit pulse accumulators PAC3 and PAC2 can be enabled only if PAEN in PATCL (\$20) is cleared. If PAEN is set, PA3EN and PA2EN have no effect.

The 8-bit pulse accumulators PAC1 and PAC0 can be enabled only if PBEN in PBTCL (\$30) is cleared. If PBEN is set, PA1EN and PA0EN have no effect.

Read or write any time.

PAXEN — 8-Bit Pulse Accumulator 'x' Enable

1 = 8-Bit Pulse Accumulator is enabled.

0 = 8-Bit Pulse Accumulator is disabled.

Delay Counter Control Register (DLYCT)

Register offset: \$0029

	Bit 7	6	5	4	3	2	1	Bit 0
	0	0	0	0	0	0	DLY1	DLY0
RESET:	0	0	0	0	0	0	0	0

Read or write any time.

If enabled, after detection of a valid edge on input capture pin, the delay counter counts the pre-selected number of M clock (module clock) cycles, then it will generate a pulse on its output. The pulse is generated only if the level of input signal, after the preset delay, is the opposite of the level before the transition. This will avoid reaction to narrow input pulses.

After counting, the counter will be cleared automatically.

Delay between two active edges of the input signal period should be longer than the selected counter delay.

DLYx — Delay Counter Select

Table 62 Delay Counter Select

DLY1	DLY0	Delay
0	0	Disabled (bypassed)
0	1	256M clock cycles
1	0	512M clock cycles
1	1	1024 M clock cycles

Here 'M' refers to module clock.

**Input Control
Overwrite Register
(ICOVW)**

Register offset: \$002A

	Bit 7	6	5	4	3	2	1	Bit 0
NOVW7	NOVW6	NOVW5	NOVW4	NOVW3	NOVW2	NOVW1	NOVW0	
RESET:	0	0	0	0	0	0	0	0

Read or write any time.

An IC register is empty when it has been read or latched into the holding register.

A holding register is empty when it has been read.

Enhanced Capture Timer (ECT)

NOVWx — No Input Capture Overwrite

- 1 = The related capture register or holding register cannot be written by an event unless they are empty (see [IC Channels](#)). This will prevent the captured value to be overwritten until it is read or latched in the holding register.
- 0 = The contents of the related capture register or holding register can be overwritten when a new input capture or latch occurs.

**Input Control
System Control
Register (ICSYS)**

Register offset: \$002B

	Bit 7	6	5	4	3	2	1	Bit 0
	SH37	SH26	SH15	SH04	TFMOD	PACMX	BUFEN	LATQ
RESET:	0	0	0	0	0	0	0	0

Read: any time

Write: May be written once (test_mode = 0). Writes are always permitted when test_mode = 1.

SHxy — Share Input action of Input Capture Channels x and y

- 1 = The channel input 'x' causes the same action on the channel 'y'. The port pin 'x' and the corresponding edge detector is used to be active on the channel 'y'.
- 0 = Normal operation

TFMOD — Timer Flag-setting Mode

Use of the TFMOD bit in the ICSYS register (\$2B) in conjunction with the use of the ICOVW register (\$2A) allows a timer interrupt to be generated after capturing two values in the capture and holding registers instead of generating an interrupt for every capture.

By setting TFMOD in queue mode, when NOVW bit is set and the corresponding capture and holding registers are emptied, an input capture event will first update the related input capture register with the main timer contents. At the next event the TCn data is transferred to the TCnH register, The TCn is updated and the CnF interrupt flag is set. See [Figure 58](#).

In all other input capture cases the interrupt flag is set by a valid external event on PTn.

1 = If in queue mode (BUFEN=1 and LATQ=0), the timer flags C3F–C0F in TFLG1 (\$0E) are set only when a latch on the corresponding holding register occurs.

If the queue mode is not engaged, the timer flags C3F–C0F are set the same way as for TFMOD=0.

0 = The timer flags C3F–C0F in TFLG1 (\$0E) are set when a valid input capture transition on the corresponding port pin occurs.

PACMX — 8-Bit Pulse Accumulators Maximum Count

1 = When the 8-bit pulse accumulator has reached the value \$FF, it will not be incremented further. The value \$FF indicates a count of 255 or more.

0 = Normal operation. When the 8-bit pulse accumulator has reached the value \$FF, with the next active edge, it will be incremented to \$00.

BUFEN — IC Buffer Enable

1 = Input Capture and pulse accumulator holding registers are enabled. The latching mode is defined by LATQ control bit. Write one into ICLAT bit in MCCTL (\$26), when LATQ is set will produce latching of input capture and pulse accumulators registers into their holding registers.

0 = Input Capture and pulse accumulator holding registers are disabled.

LATQ — Input Control Latch or Queue Mode Enable

The BUFEN control bit should be set in order to enable the IC and pulse accumulators holding registers. Otherwise LATQ latching modes are disabled.

Write one into ICLAT bit in MCCTL (\$26), when LATQ and BUFEN are set will produce latching of input capture and pulse accumulators registers into their holding registers.

1 = Latch Mode is enabled. Latching function occurs when modulus down-counter reaches zero or a zero is written into the count register MCCNT (see [Buffered IC Channels](#)).

Enhanced Capture Timer (ECT)

With a latching event the contents of IC registers and 8-bit pulse accumulators are transferred to their holding registers. 8-bit pulse accumulators are cleared.

0 = Queue Mode of Input Capture is enabled.

The main timer value is memorized in the IC register by a valid input pin transition.

With a new occurrence of a capture, the value of the IC register will be transferred to its holding register and the IC register memorizes the new timer value.

Timer Test Register (TIMTST)

Register offset: \$002D

	Bit 7	6	5	4	3	2	1	Bit 0
	0	0	0	0	0	0	TCBYP	0
RESET	0	0	0	0	0	0	0	0

Read: any time

Write: only in special mode (test_mode = 1).

TCBYP — Main Timer Divider Chain Bypass

1 = For testing only. The 16-bit free-running timer counter is divided into two 8-bit halves and the prescaler is bypassed. The clock drives both halves directly.

When the high byte of timer counter TCNT (\$04) overflows from \$FF to \$00, the TOF flag in TFLG2 (\$0F) will be set.

0 = Normal operation

**16-Bit Pulse
Accumulator B
Control Register
(PBCTL)**

Register offset: \$0030

	Bit 7	6	5	4	3	2	1	Bit 0
	0	PBEN	0	0	0	0	PBOVI	0
RESET:	0	0	0	0	0	0	0	0

Read or write any time.

16-Bit Pulse Accumulator B (PACB) is formed by cascading the 8-bit pulse accumulators PAC1 and PAC0.

When PBEN is set, the PACB is enabled. The PACB shares the input pin with IC0.

PBEN — Pulse Accumulator B System Enable

- 1 = Pulse Accumulator B system enabled. The two 8-bit pulse accumulators PAC1 and PAC0 are cascaded to form the PACB 16-bit pulse accumulator. When PACB is enabled, the PACN1 and PACN0 registers contents are respectively the high and low byte of the PACB. PA1EN and PA0EN control bits in ICPAR (\$28) have no effect.
- 0 = 16-bit Pulse Accumulator system disabled. 8-bit PAC1 and PAC0 can be enabled when their related enable bits in ICPAR (\$28) are set.

PBEN is independent from TEN. With timer disabled, the pulse accumulator can still function unless pulse accumulator is disabled.

PBOVI — Pulse Accumulator B Overflow Interrupt enable

- 1 = interrupt requested if PBOVF is set
- 0 = interrupt inhibited

Enhanced Capture Timer (ECT)
**Pulse Accumulator
B Flag Register
(PBFLG)**

Register offset: \$0031

	Bit 7	6	5	4	3	2	1	Bit 0
	0	0	0	0	0	0	PBOVF	0
RESET:	0	0	0	0	0	0	0	0

Read or write any time.

PBOVF — Pulse Accumulator B Overflow Flag

This bit is set when the 16-bit pulse accumulator B overflows from \$FFFF to \$0000, or when 8-bit pulse accumulator 1 (PAC1) overflows from \$FF to \$00.

This bit is cleared by a write to the PBFLG register with bit 1 set.

Any access to the PACN1 and PACN0 registers will clear the PBOVF flag in this register when TFFCA bit in register TSCR(\$06) is set.

When PACMX=1, PBOVF bit can also be set if 8-bit pulse accumulator 1 (PAC1) reaches \$FF and followed an active edge comes on PT1.

**8-Bit Pulse
Accumulators
Holding Registers
(PA3H–PA0H)**

Register offset: \$0032–\$0035

PA3H	Bit 7	6	5	4	3	2	1	Bit 0
PA2H	Bit 7	6	5	4	3	2	1	Bit 0
PA1H	Bit 7	6	5	4	3	2	1	Bit 0
PA0H	Bit 7	6	5	4	3	2	1	Bit 0
RESET:	0	0	0	0	0	0	0	0

Read: any time

Write: has no effect.

These registers are used to latch the value of the corresponding pulse accumulator when the related bits in register ICPAR (\$28) are enabled (see [Pulse Accumulators](#)).

**Modulus
Down-Counter
Count Register
(MCCNT)**

Register offset: \$0036–\$0037

	Bit 15	14	13	12	11	10	9	Bit 8
	Bit 7	6	5	4	3	2	1	Bit 0
RESET:	1	1	1	1	1	1	1	1

Read or write any time.

A full access for the counter register should take place in one clock cycle. A separate read/write for high byte and low byte will give different result than accessing them as a word.

If the RDMCL bit in MCCTL register is cleared, reads of the MCCNT register will return the present value of the count register. If the RDMCL bit is set, reads of the MCCNT will return the contents of the load register.

If a \$0000 is written into MCCNT and modulus counter while LATQ and BUFEN in ICSYS (\$2B) register are set, the input capture and pulse accumulator registers will be latched.

With a \$0000 write to the MCCNT, the modulus counter will stay at zero and does not set the MCZF flag in MCFLG register.

If modulus mode is enabled (MODMC=1), a write to this address will update the load register with the value written to it. The count register will not be updated with the new value until the next counter underflow.

The FLMC bit in MCCTL (\$26) can be used to immediately update the count register with the new value if an immediate load is desired.

Enhanced Capture Timer (ECT)

If modulus mode is not enabled (MODMC=0), a write to this address will clear the prescaler and will immediately update the counter register with the value written to it and down-counts once to \$0000

**Timer Input
Capture Holding
Registers 0–3
(TC0H–TC3H)**

Register offset: \$0038–\$003F

TC0H	Bit 15	14	13	12	11	10	9	Bit 8
	Bit 7	6	5	4	3	2	1	Bit 0
TC1H	Bit 15	14	13	12	11	10	9	Bit 8
	Bit 7	6	5	4	3	2	1	Bit 0
TC2H	Bit 15	14	13	12	11	10	9	Bit 8
	Bit 7	6	5	4	3	2	1	Bit 0
TC3H	Bit 15	14	13	12	11	10	9	Bit 8
	Bit 7	6	5	4	3	2	1	Bit 0
RESET	0	0	0	0	0	0	0	0

Read: any time
Write: has no effect.

These registers are used to latch the value of the input capture registers TC0–TC3. The corresponding IOSx bits in TIOS (\$00) should be cleared (see [IC Channels](#)).

Modes of Operation

The Enhanced Capture Timer has 8 Input Capture, Output Compare (IC/OC) channels same as on the HC12 standard timer (timer channels TC0 to TC7). When channels are selected as input capture by selecting the IOSx bit in TIOS register, they are called Input Capture (IC) channels.

Four IC channels are the same as on the standard timer with one capture register each which memorizes the timer value captured by an action on the associated input pin.

Four other IC channels, in addition to the capture register, have also one buffer each called holding register. This permits to memorize two different timer values without generation of any interrupt.

Four 8-bit pulse accumulators are associated with the four buffered IC channels. Each pulse accumulator has a holding register to memorize their value by an action on its external input. Each pair of pulse accumulators can be used as a 16-bit pulse accumulator.

The 16-bit modulus down-counter can control the transfer of the IC registers contents and the pulse accumulators to the respective holding registers for a given period, every time the count reaches zero.

The modulus down-counter can also be used as a stand-alone time base with periodic interrupt capability.

IC Channels

The IC channels are composed of four standard IC registers and four buffered IC channels.

An **IC register** is **empty** when it has been read or latched into the holding register.

A **holding register** is **empty** when it has been read.

Non-Buffered IC Channels

The main timer value is memorized in the IC register by a valid input pin transition. If the corresponding NOVWx bit of the ICOVW register is

Enhanced Capture Timer (ECT)

cleared, with a new occurrence of a capture, the contents of IC register are overwritten by the new value.

If the corresponding NOVWx bit of the ICOVW register is set, the capture register cannot be written unless it is empty.

This will prevent the captured value to be overwritten until it is read.

Buffered IC Channels

There are two modes of operations for the buffered IC channels.

- IC Latch Mode:

When enabled (LATQ=1), the main timer value is memorized in the IC register by a valid input pin transition.

The value of the buffered IC register is latched to its holding register by the Modulus counter for a given period when the count reaches zero, by a write \$0000 to the modulus counter or by a write to ICLAT in the MCCTL register.

If the corresponding NOVWx bit of the ICOVW register is cleared, with a new occurrence of a capture, the contents of IC register are overwritten by the new value. In case of latching, the contents of its holding register are overwritten.

If the corresponding NOVWx bit of the ICOVW register is set, the capture register or its holding register cannot be written by an event unless they are empty (see [IC Channels](#)). This will prevent the captured value to be overwritten until it is read or latched in the holding register.

- IC queue mode:

When enabled (LATQ=0), the main timer value is memorized in the IC register by a valid input pin transition.

If the corresponding NOVWx bit of the ICOVW register is cleared, with a new occurrence of a capture, the value of the IC register will be transferred to its holding register and the IC register memorizes the new timer value.

If the corresponding NOVWx bit of the ICOVW register is set, the capture register or its holding register cannot be written by an event unless they are empty (see [IC Channels](#)).

In queue mode, reads of holding register will latch the corresponding pulse accumulator value to its holding register.

Pulse Accumulators

There are four 8-bit pulse accumulators with four 8-bit holding registers associated with the four IC buffered channels. A pulse accumulator counts the number of active edges at the input of its channel.

The user can prevent 8-bit pulse accumulators counting further than \$FF by PACMX control bit in ICSYS (\$2B). In this case a value of \$FF means that 255 counts or more have occurred.

Each pair of pulse accumulators can be used as a 16-bit pulse accumulator.

There are two modes of operation for the pulse accumulators.

Pulse Accumulator latch mode

The value of the pulse accumulator is transferred to its holding register when the modulus down-counter reaches zero, a write \$0000 to the modulus counter or when the force latch control bit ICLAT is written.

At the same time the pulse accumulator is cleared.

Pulse Accumulator queue mode

When queue mode is enabled, reads of an input capture holding register will transfer the contents of the associated pulse accumulator to its holding register.

At the same time the pulse accumulator is cleared.

Modulus Down-Counter

The modulus down-counter can be used as a time base to generate a periodic interrupt. It can also be used to latch the values of the IC registers and the pulse accumulators to their holding registers.

The action of latching can be programmed to be periodic or only once.

Enhanced Capture Timer (ECT)

Interrupts

This section describes interrupts originated by the ECT block. The MCU must service the interrupt requests. [Table 63](#) lists the interrupts generated by the ECT to communicate with the MCU.

Table 63 ECT Interrupts

Interrupt	Offset (1)	Vector ¹	Priority ¹	Source	Description
ectch_int[7:0]	–	–	–	Timer Channel 7–0	Active high timer channel interrupts 7–0
ectmcufi_int	–	–	–	Modulus counter underflow	Active high modulus counter interrupt
ectpabo_int	–	–	–	Pulse Accumulator B Overflow	Active high pulse accumulator B interrupt
ectpaai_int	–	–	–	Pulse Accumulator A Input	Active high pulse accumulator A input interrupt
ectpao_int	–	–	–	Pulse Accumulator A Overflow	Pulse accumulator overflow interrupt
ectovi_int	–	–	–	Timer Overflow	Timer Overflow interrupt

1. Chip Dependent

Description of Interrupt Operation

The ECT only originates interrupt requests. The following is a description of how the ECT makes a request and how the MCU should acknowledge that request. The interrupt vector offset and interrupt number are chip dependent.

**Channel [7:0]
Interrupt
(ectch_int[7:0])**

This active high output will be asserted by the module to request a timer channel 7–0 interrupt to be serviced by the system controller.

**Modulus Counter
Interrupt
(ectmcufi_int)**

This active high output will be asserted by the module to request a modulus counter underflow interrupt to be serviced by the system controller.

**Pulse
Accumulator B
Overflow Interrupt
(ectpabo_int)**

This active high output will be asserted by the module to request a timer pulse accumulator B overflow interrupt to be serviced by the system controller.

**Pulse
Accumulator A
Input Interrupt
(ectpaai_int)**

This active high output will be asserted by the module to request a timer pulse accumulator A input interrupt to be serviced by the system controller.

**Pulse
Accumulator A
Overflow Interrupt
(ectpaao_int)**

This active high output will be asserted by the module to request a timer pulse accumulator A overflow interrupt to be serviced by the system controller.

**Timer Overflow
Interrupt
(ectovi_int)**

This active high output will be asserted by the module to request a timer overflow interrupt to be serviced by the system controller.



Serial Communications Interface (SCI)

Contents

Overview	389
Features	389
Modes of Operation	390
SCI Interface Diagram	392
Block Diagram	392
Signal Descriptions	393
Module Memory Map	394
Register Quick Reference	395
Register Descriptions	396
Functional Description	406
Modes of Operation	424
Interrupt Operation	425

Overview

The SCI allows asynchronous serial communications with peripheral devices and other CPUs.

Features

The SCI includes these distinctive features:

- Full-duplex operation
- Standard mark/space non-return-to-zero (NRZ) format
- 13-bit baud rate selection
- Programmable 8-bit or 9-bit data format

Serial Communications Interface (SCI)

- Separately enabled transmitter and receiver
- Programmable transmitter output parity
- Two receiver wakeup methods:
 - Idle line wakeup
 - Address mark wakeup
- Interrupt-driven operation with eight flags:
 - Transmitter empty
 - Transmission complete
 - Receiver full
 - Idle receiver input
 - Receiver overrun
 - Noise error
 - Framing error
 - Parity error
- Receiver framing error detection
- Hardware parity checking
- 10/13 bit software selectable break character length¹
- 1/16 bit-time noise detection
- Fully scan testable design

Modes of Operation

The SCI functions the same in normal, special, and emulation modes. It has two low power modes, wait and stop modes.

- Run Mode

This is the basic mode of operation.

1. This feature is not available on the first mask set (0K36N)

- Wait Mode

SCI operation in wait mode is a configurable low power mode. Depending on the state of internal bits, the SCI can operate normally when the CPU is in wait mode or the SCI clock generation can be turned off and the SCI module enters a power conservation state during wait mode. In the later case, any transmission or reception in progress stops at wait mode entry.

- Stop Mode

The SCI is inactive in stop mode for reduced power consumption. The STOP instruction does not affect SCI register states.

Serial Communications Interface (SCI)

SCI Interface Diagram

Block Diagram

Figure 63 is a block diagram of the SCI.

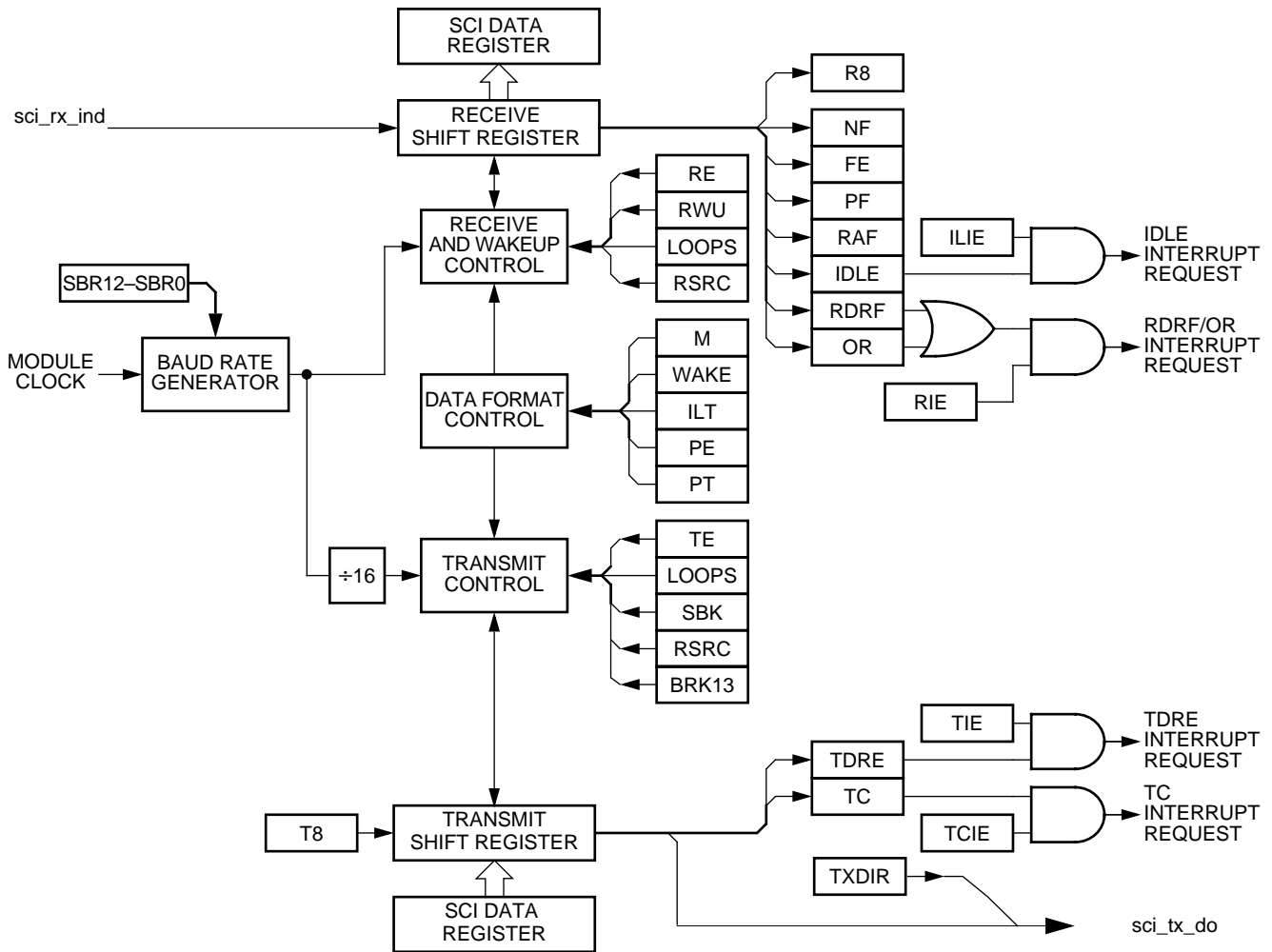

Figure 63 SCI Block Diagram

Signal Descriptions
Table 64 Signal Properties

Name	Function
sci_rx_ind	Receive input signal from pad
sci_rx_do	Receive data output from module
sci_rx_port_en	Receive enable signal
sci_rx_obe	Receive input/output configure
sci_tx_ind	Transmit input signal from pad
sci_tx_do	Transmit data output from module
sci_tx_port_en	Transmit enable signal
sci_tx_obe	Transmit input/output configure

Detailed Descriptions

- sci_rx_ind* This is the unsynchronized receiver input from the pad.
- sci_rx_do* This is the receive data output from the module.
- sci_rx_port_en* Receiver enable signal. This signal is an output of the SCI and is made active when the SCI wants to control the receive pad.
- sci_rx_obe* If the pad is controlled by the SCI, then this signal determines whether the SCI will drive **sci_rx_do**.
- sci_tx_ind* This is the unsynchronized transmitter input from the pad.
- sci_tx_do* This is the transmit data output from the module.
- sci_tx_port_en* Transmitter enable signal. This signal is an output of the SCI and is made active when the SCI wants to control the transmit pad.

Serial Communications Interface (SCI)

sci_tx_obe If the pad is controlled by the SCI, then this signal determines whether the SCI will drive **sci_tx_do**.

Interrupt Signal The SCI has one interrupt signal. Refer to the [Interrupt Operation](#) subsection for more details.

Module Memory Map

The memory map for the SCI module is given below in [Table 65](#). The Address listed for each register is the address offset. The total address for each register is the sum of the base address for the SCI module and the address offset for each register.

Table 65 Module Memory Map

Offset	Use	Access
\$000	SCI Baud Rate Register High (SCIBDH)	Read/Write
\$001	SCI Baud Rate Register Low (SCIBDL)	Read/Write
\$002	SCI Control Register1 (SCICR1)	Read/Write
\$003	SCI Control Register 2 (SCICR2)	Read/Write
\$004	SCI Status Register 1 (SCISR1)	Read
\$005	SCI Status Register 2(SCISR2)	Read/Write
\$006	SCI Data Register High (SCIDRH)	Read/Write
\$007	SCI Data Register Low (SCIDRL)	Read/Write

Register Quick Reference

Register name		Bit 7	6	5	4	3	2	1	Bit 0	Addr. offset
SCIBDH	Read:	0	0	0	SBR12	SBR11	SBR10	SBR9	SBR8	\$000
	Write:									
SCIBDL	Read:	SBR7	SBR6	SBR5	SBR4	SBR3	SBR2	SBR1	SBR0	\$001
	Write:									
SCICR1	Read:	LOOPS	SCISWAI	RSRC	M	WAKE	ILT	PE	PT	\$002
	Write:									
SCICR2	Read:	TIE	TCIE	RIE	ILIE	TE	RE	RWU	SBK	\$003
	Write:									
SCISR1	Read:	TDRE	TC	RDRF	IDLE	OR	NF	FE	PF	\$004
	Write:									
SCISR2	Read:	0	0	0	0	0	BRK13	TXDIR	RAF	\$005
	Write:									
SCIDRH	Read:	R8	T8	0	0	0	0	0	0	\$006
	Write:									
SCIDRL	Read:	R7	R6	R5	R4	R3	R2	R1	R0	\$007
	Write:	T7	T6	T5	T4	T3	T2	T1	T0	

= Reserved or unimplemented

Figure 64 SCI Register Quick Reference

Serial Communications Interface (SCI)

Register Descriptions

This section consists of register descriptions in address order. Each description includes a standard register diagram with an associated figure number. Writes to a reserved register location do not have any effect and reads of these locations return a zero. Details of register bit and field function follow the register diagrams, in bit order.

SCI Baud Rate Registers (SCIBDH/L)

Address Offset: \$000

	7	6	5	4	3	2	1	0
R	0	0	0	SBR12	SBR11	SBR10	SBR9	SBR8
W								

RESET: 0 0 0 0 0 0 0 0 0

= Unimplemented or Reserved

Address Offset: \$001

	7	6	5	4	3	2	1	0
R	SBR7	SBR6	SBR5	SBR4	SBR3	SBR2	SBR1	SBR0
W								

RESET: 0 0 0 0 0 0 1 0 0

= Unimplemented or Reserved

The SCI Baud Rate Register is used by the counter to determine the baud rate of the SCI. The formula for calculating the baud rate is:

$$\text{SCI baud rate} = \text{SCI module clock} / (16 \times \text{BR}),$$

where BR is the content of the SCI baud rate registers, bits SBR12 through SBR0. The baud rate registers can contain a value from 1 to 8191.

Read: anytime. A read will not return the correct data if only SCIBDH is written to. SCIBDL must also be written to, following a write to SCIBDH.

Write: anytime

SBR12–SBR0 — SCI Baud Rate Bits

The baud rate for the SCI is determined by these 13 bits.

NOTE: *The baud rate generator is disabled until the TE bit or the RE bit is set for the first time after reset. The baud rate generator is disabled when BR = 0.*

NOTE: *Writing to SCIBDH has no effect without writing to SCIBDL, since writing to SCIBDH puts the data in a temporary location until SCIBDL is written to.*

SCI Control Register 1

Address Offset: \$002

	7	6	5	4	3	2	1	0
R	LOOPS	SCISWAI	RSRC	M	WAKE	ILT	PE	PT
W								
RESET:	0	0	0	0	0	0	0	0

 = Unimplemented or Reserved

Read: anytime

Write: anytime

LOOPS — Loop Select Bit

LOOPS enables loop operation. In loop operation, the RXD pin is disconnected from the SCI and the transmitter output is internally connected to the receiver input. Both the transmitter and the receiver must be enabled to use the loop function.

1 = Loop operation enabled

0 = Normal operation enabled

The receiver input is determined by the RSRC bit.

SCISWAI — SCI Stop in Wait Mode Bit

SCISWAI disables the SCI in wait mode.

1 = SCI disabled in wait mode

Serial Communications Interface (SCI)

0 = SCI enabled in wait mode

RSRC — Receiver Source Bit

When LOOPS = 1, the RSRC bit determines the source for the receiver shift register input.

1 = Receiver input connected externally to transmitter

0 = Receiver input internally connected to transmitter output

Table 66 Loop Functions

LOOPS	RSRC	Function
0	x	Normal operation
1	0	Loop mode with Rx input internally connected to Tx output
1	1	Single-wire mode with Rx input connected to sci_tx_ind

M — Data Format Mode Bit

MODE determines whether data characters are eight or nine bits long.

1 = One start bit, nine data bits, one stop bit

0 = One start bit, eight data bits, one stop bit

WAKE — Wakeup Condition Bit

WAKE determines which condition wakes up the SCI: a logic 1 (address mark) in the most significant bit position of a received data character or an idle condition on the **sci_rx_ind**.

1 = Address mark wakeup

0 = Idle line wakeup

ILT — Idle Line Type Bit

ILT determines when the receiver starts counting logic 1s as idle character bits. The counting begins either after the start bit or after the stop bit. If the count begins after the start bit, then a string of logic 1s preceding the stop bit may cause false recognition of an idle character. Beginning the count after the stop bit avoids false idle character recognition, but requires properly synchronized transmissions.

1 = Idle character bit count begins after stop bit

0 = Idle character bit count begins after start bit

PE — Parity Enable Bit

PE enables the parity function. When enabled, the parity function inserts a parity bit in the most significant bit position.

- 1 = Parity function enabled
- 0 = Parity function disabled

PT — Parity Type Bit

PT determines whether the SCI generates and checks for even parity or odd parity. With even parity, an even number of 1s clears the parity bit and an odd number of 1s sets the parity bit. With odd parity, an odd number of 1s clears the parity bit and an even number of 1s sets the parity bit.

- 1 = Odd parity
- 0 = Even parity

**SCI Control
Register 2
(SCICR2)**

Address Offset: \$003

	7	6	5	4	3	2	1	0
R	TIE	TCIE	RIE	ILIE	TE	RE	RWU	SBK
W								
RESET:	0	0	0	0	0	0	0	0

= Unimplemented or Reserved

Read: anytime
Write: anytime

TIE — Transmitter Interrupt Enable Bit

TIE enables the transmit data register empty flag, TDRE, to generate interrupt requests.

- 1 = TDRE interrupt requests enabled
- 0 = TDRE interrupt requests disabled

Serial Communications Interface (SCI)

TCIE — Transmission Complete Interrupt Enable Bit

TCIE enables the transmission complete flag, TC, to generate interrupt requests.

- 1 = TC interrupt requests enabled
- 0 = TC interrupt requests disabled

RIE — Receiver Full Interrupt Enable Bit

RIE enables the receive data register full flag, RDRF, or the overrun flag, OR, to generate interrupt requests.

- 1 = RDRF and OR interrupt requests enabled
- 0 = RDRF and OR interrupt requests disabled

ILIE — Idle Line Interrupt Enable Bit

ILIE enables the idle line flag, IDLE, to generate interrupt requests.

- 1 = IDLE interrupt requests enabled
- 0 = IDLE interrupt requests disabled

TE — Transmitter Enable Bit

TE enables the SCI transmitter and configures the TXD pin as being controlled by the SCI. The TE bit can be used to queue an idle preamble.

- 1 = Transmitter enabled
- 0 = Transmitter disabled

RE — Receiver Enable Bit

RE enables the SCI receiver.

- 1 = Receiver enabled
- 0 = Receiver disabled

RWU — Receiver Wakeup Bit

Standby state

- 1 = Normal operation
- 0 = RWU enables the wakeup function and inhibits further receiver interrupt requests. Normally, hardware wakes the receiver by automatically clearing RWU.

SBK — Send Break Bit

Toggling SBK sends one break character (10 or 11 logic 0s, respectively 13 or 14 logics 0s if BRK13 is set). Toggling implies clearing the SBK bit before the break character has finished transmitting. As long as SBK is set, the transmitter continues to send complete break characters (10 or 11, respectively 13 or 14 bits).

- 1 = Transmit break characters
- 0 = No break characters

SCI Status Register 1 (SCISR1)

The SCISR1 and SCISR2 register provides inputs to the MCU for generation of SCI interrupts. Also, these registers can be polled by the MCU to check the status of these bits. The flag-clearing procedures require that the status register be read followed by a read or write to the SCI Data Register. It is permissible to execute other instructions between the two steps as long as it does not compromise the handling of I/O, but the order of operations is important for flag clearing.

Address Offset: \$004

	7	6	5	4	3	2	1	0
R	TDRE	TC	RDRF	IDLE	OR	NF	FE	PF
W								
RESET:	1	1	0	0	0	0	0	0

 = Unimplemented or Reserved

Read: anytime

Write: has no meaning or effect

TDRE — Transmit Data Register Empty Flag

TDRE is set when the transmit shift register receives a byte from the SCI data register. When TDRE is 1, the transmit data register (SCIDRH/L) is empty and can receive a new value to transmit. Clear TDRE by reading SCI status register 1 (SCISR1) with TDRE set and then writing to SCI data register low (SCIDRL).

- 1 = Byte transferred to transmit shift register; transmit data register empty
- 0 = No byte transferred to transmit shift register

Serial Communications Interface (SCI)

TC — Transmit Complete Flag

TC is set low when there is a transmission in progress or when a preamble or break character is loaded. TC is set high when the TDRE flag is set and no data, preamble, or break character is being transmitted. When TC is set, the `sci_tx_do` becomes idle (logic 1). Clear TC by reading SCI status register 1 (SCISR1) with TC set and then writing to SCI data register low (SCIDRL). TC is cleared automatically when data, preamble, or break is queued and ready to be sent. TC is cleared in the event of a simultaneous set and clear of the TC flag (transmission not complete).

- 1 = No transmission in progress
- 0 = Transmission in progress

RDRF — Receive Data Register Full Flag

RDRF is set when the data in the receive shift register transfers to the SCI data register. Clear RDRF by reading SCI status register 1 (SCISR1) with RDRF set and then reading SCI data register low (SCIDRL).

- 1 = Received data available in SCI data register
- 0 = Data not available in SCI data register

IDLE — Idle Line Flag

IDLE is set when 10 consecutive logic 1s (if M=0) or 11 consecutive logic 1s (if M=1) appear on the receiver input. Once the IDLE flag is cleared, a valid frame must again set the RDRF flag before an idle condition can set the IDLE flag. Clear IDLE by reading SCI status register 1 (SCISR1) with IDLE set and then reading SCI data register low (SCIDRL).

- 1 = Receiver input has become idle
- 0 = Receiver input is either active now or has never become active since the IDLE flag was last cleared

NOTE: *When the receiver wakeup bit (RWU) is set, an idle line condition does not set the IDLE flag.*

OR — Overrun Flag

OR is set when software fails to read the SCI data register before the receive shift register receives the next frame. The OR bit is set immediately after the stop bit has been completely received for the second frame. The data in the shift register is lost, but the data already in the SCI data registers is not affected. Clear OR by reading SCI status register 1 (SCISR1) with OR set and then reading SCI data register low (SCIDRL).

- 1 = Overrun
- 0 = No overrun

NF — Noise Flag

NF is set when the SCI detects noise on the receiver input. NF bit is set during the same cycle as the RDRF flag but does not get set in the case of an overrun. Clear NF by reading SCI status register 1 (SCISR1) and then reading SCI data register low (SCIDRL).

- 1 = Noise
- 0 = No noise

FE — Framing Error Flag

FE is set when a logic 0 is accepted as the stop bit. FE bit is set during the same cycle as the RDRF flag, but does not get set in the case of an overrun. FE inhibits further data reception until it is cleared. Clear FE by reading SCI status register 1 (SCISR1) with FE set and then reading the SCI data register low (SCIDRL).

- 1 = Framing error
- 0 = No framing error

PF — Parity Error Flag

PF is set when the parity enable bit, PE, is set and the parity of the received data does not match its parity bit. Clear PF by reading SCI status register 1 (SCISR1), and then reading SCI data register low (SCIDRL).

- 1 = Parity error
- 0 = No parity error

Serial Communications Interface (SCI)

**SCI Status Register
2 (SCISR2)**

Address Offset: \$005

	7	6	5	4	3	2	1	0
R	0	0	0	0	0	BRK13	TXDIR	RAF
W								
RESET:	0	0	0	0	0	0	0	0



= Unimplemented or Reserved

Read: anytime

Write: anytime; writing accesses SCI status register 2; writing to any bits except TXDIR and BRK13 has no effect

BRK13 — Break Transmit character length

This bit determines whether the transmit break character is 10 or 11 bit respectively 13 or 14 bits long. The detection of a framing error is not affected by this bit.

- 1 = Break character is 13 or 14 bit long
- 0 = Break Character is 10 or 11 bit long

TXDIR — Transmitter pin data direction in Single-Wire mode.

This bit determines whether the TXD pin is going to be used as an input or output, in the Single-Wire mode of operation. This bit is only relevant in the Single-Wire mode of operation.

- 1 = TXD pin to be used as an output in Single-Wire mode
- 0 = TXD pin to be used as an input in Single-Wire mode

RAF — Receiver Active Flag

RAF is set when the receiver detects a logic 0 during the RT1 time period of the start bit search. RAF is cleared when the receiver detects an idle character.

- 1 = Reception in progress
- 0 = No reception in progress

**SCI Data Registers
(SCIDRH/L)**

Address Offset: \$006

	7	6	5	4	3	2	1	0
R	R8	T8	0	0	0	0	0	0
W								
RESET:	0	0	0	0	0	0	0	0

= Unimplemented or Reserved

Address Offset: \$007

	7	6	5	4	3	2	1	0
R	R7	R6	R5	R4	R3	R2	R1	R0
W	T7	T6	T5	T4	T3	T2	T1	T0
RESET:	0	0	0	0	0	0	0	0

= Unimplemented or Reserved

Read: anytime; reading accesses SCI receive data register
Write: anytime; writing accesses SCI transmit data register; writing to R8 has no effect

R8 — Received Bit 8

R8 is the ninth data bit received when the SCI is configured for 9-bit data format (M = 1).

T8 — Transmit Bit 8

T8 is the ninth data bit transmitted when the SCI is configured for 9-bit data format (M = 1).

R7–R0 — Received bits seven through zero for 9-bit or 8-bit data formats

T7–T0 — Transmit bits seven through zero for 9-bit or 8-bit formats

NOTE: *If the value of T8 is the same as in the previous transmission, T8 does not have to be rewritten. The same value is transmitted until T8 is rewritten.*

Serial Communications Interface (SCI)

NOTE: In 8-bit data format, only SCI data register low (SCIDRL) needs to be accessed.

NOTE: When transmitting in 9-bit data format and using 8-bit write instructions, write first to SCI data register high (SCIDRH), then SCIDRL.

Functional Description

This section provides a complete functional description of the SCI block, detailing the operation of the design from the end user perspective in a number of subsections.

Figure 63 shows the structure of the SCI module. The SCI allows full duplex, asynchronous, NRZ serial communication between the CPU and remote devices, including other CPUs. The SCI transmitter and receiver operate independently, although they use the same baud rate generator. The CPU monitors the status of the SCI, writes the data to be transmitted, and processes received data.

Data Format

The SCI uses the standard NRZ mark/space data format illustrated in Figure 65 below.

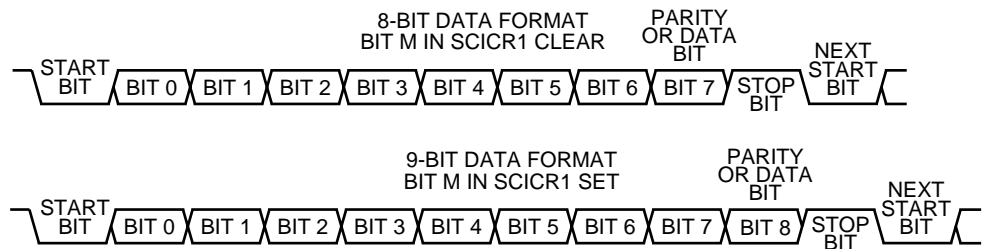

Figure 65 SCI Data Formats

Each data character is contained in a frame that includes a start bit, eight or nine data bits, and a stop bit. Clearing the M bit in SCI control register 1 configures the SCI for 8-bit data characters. A frame with eight data

bits has a total of 10 bits. Setting the M bit configures the SCI for nine-bit data characters. A frame with nine data bits has a total of 11 bits.

Table 67 Example of 8-bit Data Formats

Start Bit	Data Bits	Address Bits	Parity Bits	Stop Bit
1	8	0	0	1
1	7	0	1	1
1	7	1 ⁽¹⁾	0	1

1. The address bit identifies the frame as an address character. See section on [Receiver Wakeup](#).

When the SCI is configured for 9-bit data characters, the ninth data bit is the T8 bit in SCI data register high (SCIDRH). It remains unchanged after transmission and can be used repeatedly without rewriting it. A frame with nine data bits has a total of 11 bits.

Table 68 Example of 9-Bit Data Formats

Start Bit	Data Bits	Address Bits	Parity Bits	Stop Bit
1	9	0	0	1
1	8	0	1	1
1	8	1 ⁽¹⁾	0	1

1. The address bit identifies the frame as an address character. See section on [Receiver Wakeup](#).

Baud Rate Generation

A 13-bit modulus counter in the baud rate generator derives the baud rate for both the receiver and the transmitter. The value from 0 to 8191 written to the SBR12–SBR0 bits determines the module clock divisor. The SBR bits are in the SCI baud rate registers (SCIBDH and SCIBDL). The baud rate clock is synchronized with the bus clock and drives the receiver. The baud rate clock divided by 16 drives the transmitter. The receiver has an acquisition rate of 16 samples per bit time.

Baud rate generation is subject to two sources of error:

- Integer division of the module clock may not give the exact target frequency.

Serial Communications Interface (SCI)

- Synchronization with the bus clock can cause phase shift.

Figure 69 lists some examples of achieving target baud rates with a module clock frequency of 25 MHz

$$\text{SCI baud rate} = \text{SCI module clock} / (16 * \text{SCIBR}[12:0])$$

Table 69 Baud Rates (Example: Module Clock = 25.0 MHz)

Bits SBR[12-0]	Receiver Clock (Hz)	Transmitter Clock (Hz)	Target Baud Rate	Error (%)
14	1785714	111607	115200	-3.12
27	925926	57870	57600	0.47
41	609756	38110	38,400	-0.76
81	308642	19290	19,200	0.47
163	153374	9586	9600	-0.15
326	76687	4793	4800	-0.15
651	38402	2400	2400	0.01
1302	19201	1200	1200	0.01
2604	9601	600	600	0.01
5208	4800	300	300	0.01

NOTE: The maximum divider rate is 8191.

Transmitter

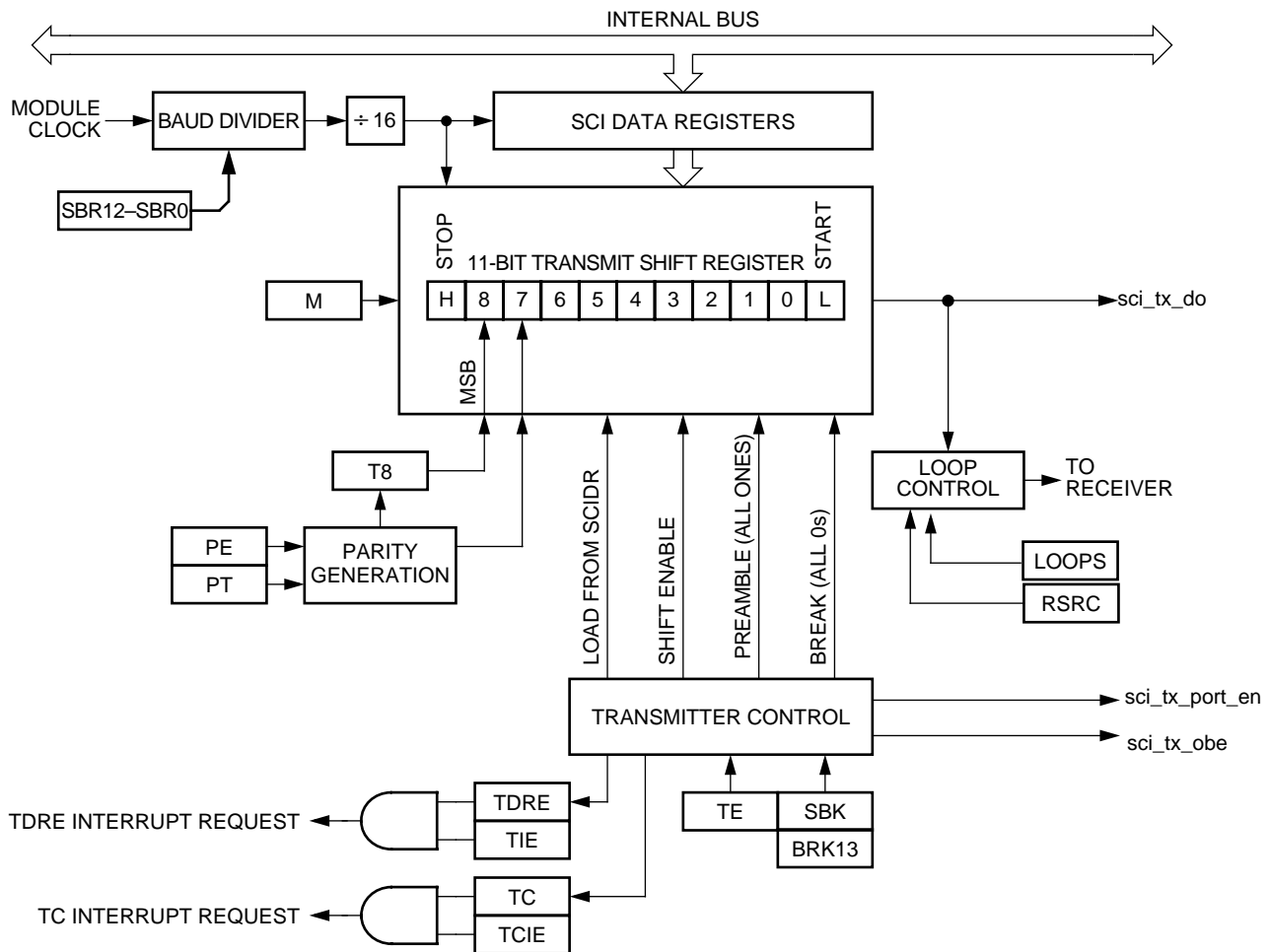

Figure 66 Transmitter Block Diagram

*Transmitter
Character Length*

The SCI transmitter can accommodate either 8-bit or 9-bit data characters. The state of the M bit in SCI control register 1 (SCICR1) determines the length of data characters. When transmitting 9-bit data, bit T8 in SCI data register high (SCIDRH) is the ninth bit (bit 8).

*Character
Transmission*

To transmit data, the MCU writes the data bits to the SCI data registers (SCIDRH/SCIDRL), which in turn are transferred to the transmitter shift register. The transmit shift register then shifts a frame out through the **sci_tx_do** signal, after it has prefaced it with a start bit and appended it

Serial Communications Interface (SCI)

with a stop bit. The SCI data registers (SCIDRH and SCIDRL) are the write-only buffers between the internal data bus and the transmit shift register.

The SCI also sets a flag, the transmit data register empty flag (TDRE), every time it transfers data from the buffer (SCIDRH/L) to the transmitter shift register. The transmit driver routine may respond to this flag by writing another byte to the Transmitter buffer (SCIDRH/SCIDRL), while the shift register is still shifting out the first byte.

To initiate an SCI transmission:

4. Configure the SCI:
 - a. Select a baud rate. Write this value to the SCI baud registers (SCIBDH/L) to begin the baud rate generator. Remember that the baud rate generator is disabled when the baud rate is zero. Writing to the SCIBDH has no effect without also writing to SCIBDL.
 - b. Write to SCICR1 to configure word length, parity, and other configuration bits (LOOPS, RSRC, M, WAKE, ILT, PE, PT).
 - c. Enable the transmitter, interrupts, receive, and wake up as required, by writing to the SCICR2 register bits (TIE, TCIE, RIE, ILIE, TE, RE, RWU, SBK). A preamble or idle character will now be shifted out of the transmitter shift register.
5. Transmit Procedure for Each Byte:
 - a. Poll the TDRE flag by reading the SCISR1 or responding to the TDRE interrupt. Keep in mind that the TDRE bit resets to one.
 - b. If the TDRE flag is set, write the data to be transmitted to SCIDRH/L, where the ninth bit is written to the T8 bit in SCIDRH if the SCI is in 9-bit data format. A new transmission will not result until the TDRE flag has been cleared.
6. Repeat step 2 for each subsequent transmission.

NOTE: *The TDRE flag is set when the shift register is loaded with the next data to be transmitted from SCIDRH/L, which happens, generally speaking, a little over half-way through the stop bit of the previous frame.*

Specifically, this transfer occurs 9/16ths of a bit time AFTER the start of the stop bit of the previous frame.

Writing the TE bit from 0 to a 1 automatically loads the transmit shift register with a preamble of 10 logic 1s (if M = 0) or 11 logic 1s (if M = 1). After the preamble shifts out, control logic transfers the data from the SCI data register into the transmit shift register. A logic 0 start bit automatically goes into the least significant bit position of the transmit shift register. A logic 1 stop bit goes into the most significant bit position.

Hardware supports odd or even parity. When parity is enabled, the most significant bit (msb) of the data character is the parity bit.

The transmit data register empty flag, TDRE, in SCI status register 1 (SCISR1) becomes set when the SCI data register transfers a byte to the transmit shift register. The TDRE flag indicates that the SCI data register can accept new data from the internal data bus. If the transmit interrupt enable bit, TIE, in SCI control register 2 (SCICR2) is also set, the TDRE flag generates a transmitter interrupt request.

When the transmit shift register is not transmitting a frame, the **sci_tx_do** signal goes to the idle condition, logic 1. If at any time software clears the TE bit in SCI control register 2 (SCICR2), the transmitter enable signal goes low and the transmit signal goes idle.

If software clears TE while a transmission is in progress (TC = 0), the frame in the transmit shift register continues to shift out. Then the **sci_tx_port_en** signal is de-asserted and the **sci_tx_do** signal goes idle even if there is data pending in the SCI data register. To avoid accidentally cutting off the last frame in a message, always wait for TDRE to go high after the last frame before clearing TE.

To separate messages with preambles of minimum idle line time, use this sequence between messages:

1. Write the last byte of the first message to SCIDRH/L.
2. Wait for the TDRE flag to go high, indicating the transfer of the last frame to the transmit shift register.
3. Queue a preamble by clearing and then setting the TE bit.
4. Write the first byte of the second message to SCIDRH/L.

Serial Communications Interface (SCI)

Break Characters Writing a logic 1 to the send break bit, SBK, in SCI control register 2 (SCICR2) loads the transmit shift register with a break character. A break character contains all logic 0s and has no start, stop, or parity bit. Break character length depends on the M bit in SCI control register 1 (SCICR1). As long as SBK is at logic 1, transmitter logic continuously loads break characters into the transmit shift register. After software clears the SBK bit, the shift register finishes transmitting the last break character and then transmits at least one logic 1. The automatic logic 1 at the end of a break character guarantees the recognition of the start bit of the next frame.

The SCI recognizes a break character when a start bit is followed by eight or nine logic 0 data bits and a logic 0 where the stop bit should be. Receiving a break character has these effects on SCI registers:

- Sets the framing error flag, FE
- Sets the receive data register full flag, RDRF
- Clears the SCI data registers (SCIDRH/L)
- May set the overrun flag, OR, noise flag, NF, parity error flag, PE, or the receiver active flag, RAF (see [SCI Status Register 1 \(SCISR1\)](#) and [SCI Status Register 2 \(SCISR2\)](#))

Idle Characters An idle character contains all logic 1s and has no start, stop, or parity bit. Idle character length depends on the M bit in SCI control register 1 (SCICR1). The preamble is a synchronizing idle character that begins the first transmission initiated after writing the TE bit from 0 to 1.

If the TE bit is cleared during a transmission, the **sci_tx_do** signal becomes idle after completion of the transmission in progress. Clearing and then setting the TE bit during a transmission queues an idle character to be sent after the frame currently being transmitted.

NOTE: *When queueing an idle character, return the TE bit to logic 1 before the stop bit of the current frame shifts out through the **sci_tx_do** signal. Setting TE after the stop bit appears on **sci_tx_do** causes data previously written to the SCI data register to be lost. Toggle the TE bit for a queued idle character while the TDRE flag is set and immediately before writing the next byte to the SCI data register.*

NOTE: If the TE bit is clear and the transmission is complete, the SCI is not the master of the TXD pin.

Receiver

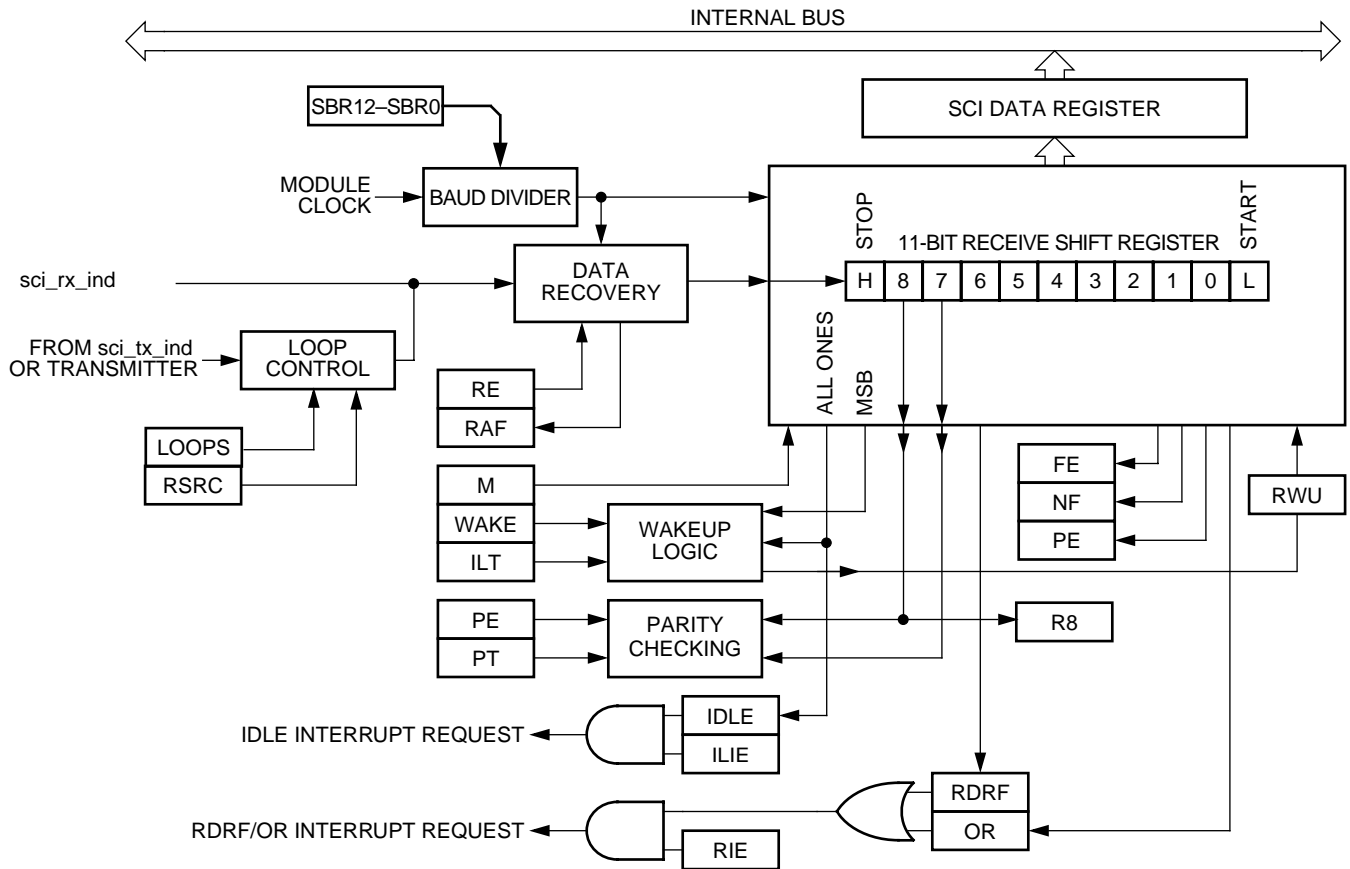

Figure 67 SCI Receiver Block Diagram

*Receiver
Character Length*

The SCI receiver can accommodate either 8-bit or 9-bit data characters. The state of the M bit in SCI control register 1 (SCICR1) determines the length of data characters. When receiving 9-bit data, bit R8 in SCI data register high (SCIDRH) is the ninth bit (bit 8).

Serial Communications Interface (SCI)

Character Reception

During an SCI reception, the receive shift register shifts a frame in from the **sci_rx_ind** signal. The SCI data register is the read-only buffer between the internal data bus and the receive shift register.

After a complete frame shifts into the receive shift register, the data portion of the frame transfers to the SCI data register. The receive data register full flag, RDRF, in SCI status register 1 (SCISR1) becomes set, indicating that the received byte can be read. If the receive interrupt enable bit, RIE, in SCI control register 2 (SCICR2) is also set, the RDRF flag generates an RDRF interrupt request.

Data Sampling

The receiver samples the **sci_rx_ind** signal at the RT clock rate. The RT clock is an internal signal with a frequency 16 times the baud rate. To adjust for baud rate mismatch, the RT clock (see [Figure 68](#)) is re-synchronized:

- After every start bit
- After the receiver detects a data bit change from logic 1 to logic 0 (after the majority of data bit samples at RT8, RT9, and RT10 returns a valid logic 1 and the majority of the next RT8, RT9, and RT10 samples returns a valid logic 0)

To locate the start bit, data recovery logic does an asynchronous search for a logic 0 preceded by three logic 1s. When the falling edge of a possible start bit occurs, the RT clock begins to count to 16.

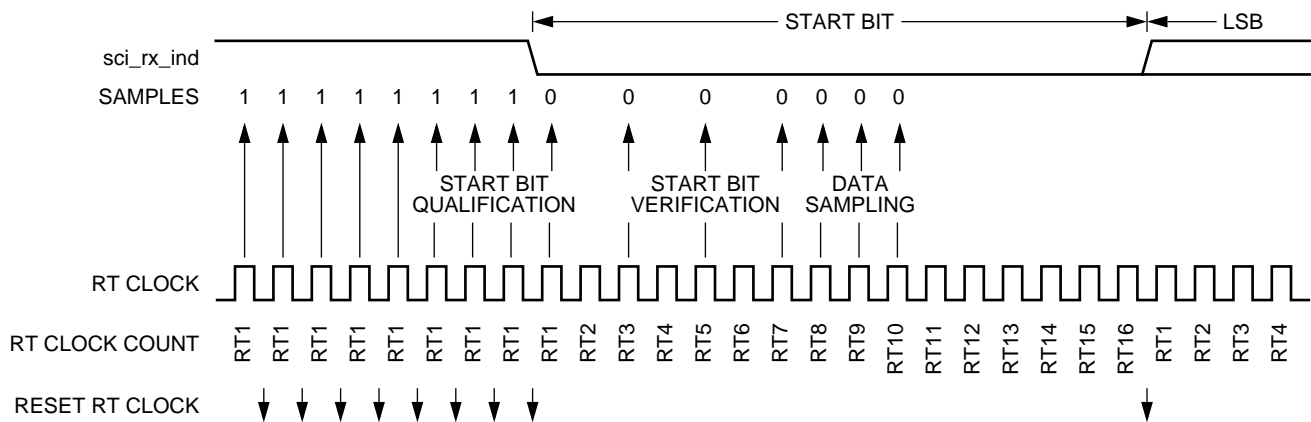

Figure 68 Receiver Data Sampling

To verify the start bit and to detect noise, data recovery logic takes samples at RT3, RT5, and RT7. [Figure 70](#) summarizes the results of the start bit verification samples.

Table 70 Start Bit Verification

RT3, RT5, and RT7 Samples	Start Bit Verification	Noise Flag
000	Yes	0
001	Yes	1
010	Yes	1
011	No	0
100	Yes	1
101	No	0
110	No	0
111	No	0

If start bit verification is not successful, the RT clock is reset and a new search for a start bit begins.

To determine the value of a data bit and to detect noise, recovery logic takes samples at RT8, RT9, and RT10. [Figure 71](#) summarizes the results of the data bit samples.

Table 71 Data Bit Recovery

RT8, RT9, and RT10 Samples	Data Bit Determination	Noise Flag
000	0	0
001	0	1
010	0	1
011	1	1
100	0	1
101	1	1
110	1	1
111	1	0

NOTE: *The RT8, RT9, and RT10 samples do not affect start bit verification. If any or all of the RT8, RT9, and RT10 start bit samples are logic 1s following a successful start bit verification, the noise flag (NF) is set and the receiver assumes that the bit is a start bit (logic 0).*

To verify a stop bit and to detect noise, recovery logic takes samples at RT8, RT9, and RT10. [Figure 72](#) summarizes the results of the stop bit samples.

Serial Communications Interface (SCI)

Table 72 Stop Bit Recovery

RT8, RT9, and RT10 Samples	Framing Error Flag	Noise Flag
000	1	0
001	1	1
010	1	1
011	0	1
100	1	1
101	0	1
110	0	1
111	0	0

In Figure 69, the verification samples RT3 and RT5 determine that the first low detected was noise and not the beginning of a start bit. The RT clock is reset and the start bit search begins again. The noise flag is not set because the noise occurred before the start bit was found.

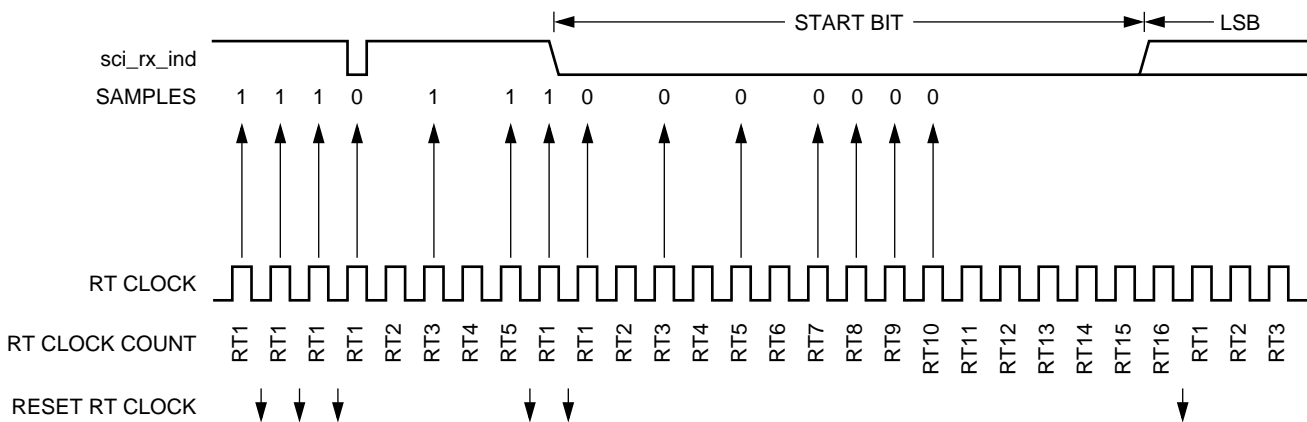

Figure 69 Start Bit Search Example 1

In Figure 70, verification sample at RT3 is high. The RT3 sample sets the noise flag. Although the perceived bit time is misaligned, the data samples RT8, RT9, and RT10 are within the bit time and data recovery is successful.

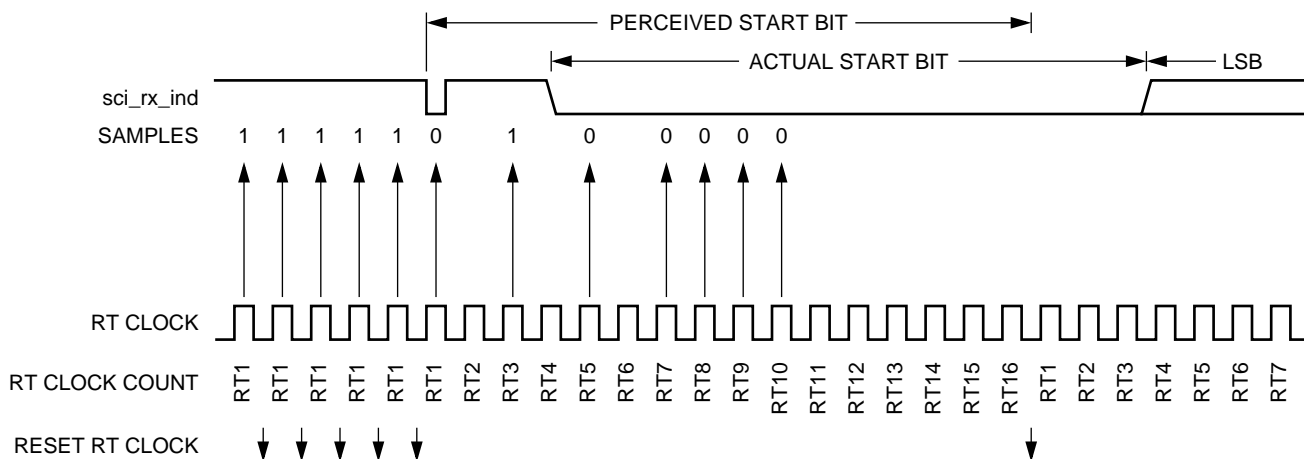

Figure 70 Start Bit Search Example 2

In [Figure 71](#), a large burst of noise is perceived as the beginning of a start bit, although the test sample at RT5 is high. The RT5 sample sets the noise flag. Although this is a worst-case misalignment of perceived bit time, the data samples RT8, RT9, and RT10 are within the bit time and data recovery is successful.

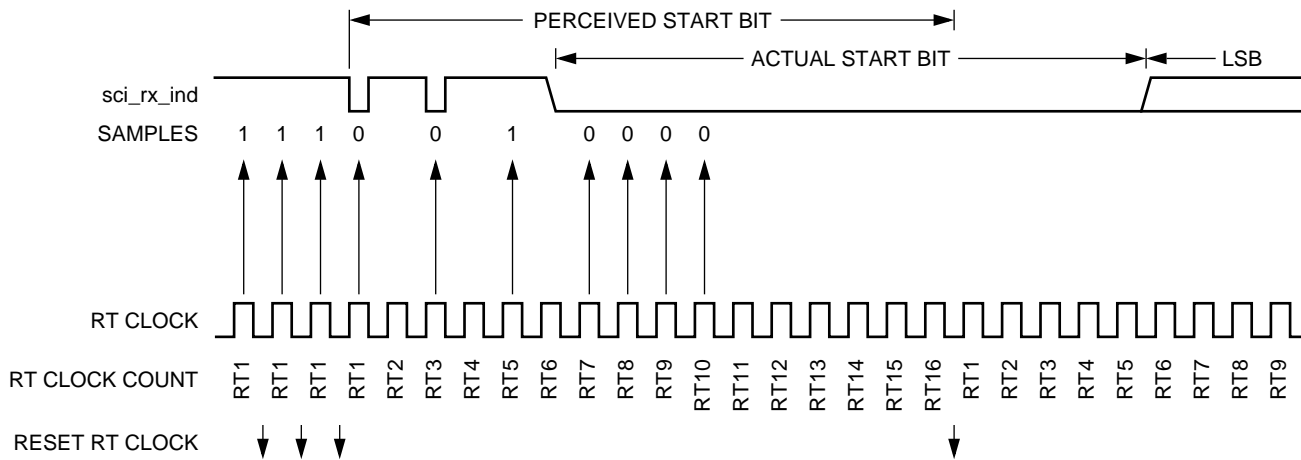

Figure 71 Start Bit Search Example 3

In [Figure 74](#), a noise burst makes the majority of data samples RT8, RT9, and RT10 high. This sets the noise flag but does not reset the RT clock. In start bits only, the RT8, RT9, and RT10 data samples are ignored.

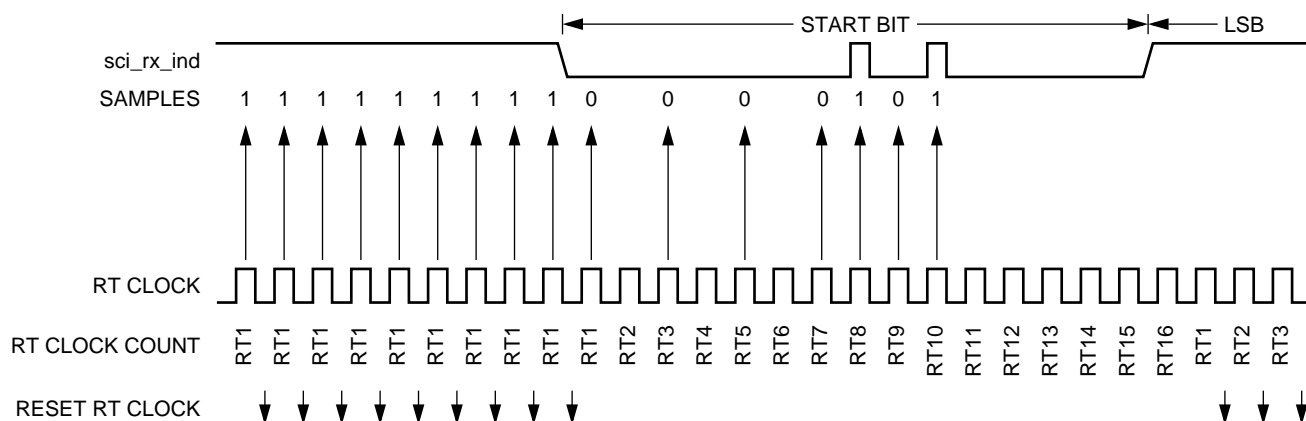

Figure 74 Start Bit Search Example 6

Framing Errors

If the data recovery logic does not detect a logic 1 where the stop bit should be in an incoming frame, it sets the framing error flag, FE, in SCI status register 1 (SCISR1). A break character also sets the FE flag because a break character has no stop bit. The FE flag is set at the same time that the RDRF flag is set.

Baud Rate Tolerance

A transmitting device may be operating at a baud rate below or above the receiver baud rate. Accumulated bit time misalignment can cause one of the three stop bit data samples (RT8, RT9, and RT10) to fall outside the actual stop bit. A noise error will occur if the RT8, RT9, and RT10 samples are not all the same logical values. A framing error will occur if the receiver clock is misaligned in such a way that the majority of the RT8, RT9, and RT10 stop bit samples are a logic zero.

As the receiver samples an incoming frame, it re-synchronizes the RT clock on any valid falling edge within the frame. Resynchronization within frames will correct a misalignment between transmitter bit times and receiver bit times.

Serial Communications Interface (SCI)

*Slow Data
Tolerance*

Figure 75 shows how much a slow received frame can be misaligned without causing a noise error or a framing error. The slow stop bit begins at RT8 instead of RT1 but arrives in time for the stop bit data samples at RT8, RT9, and RT10.

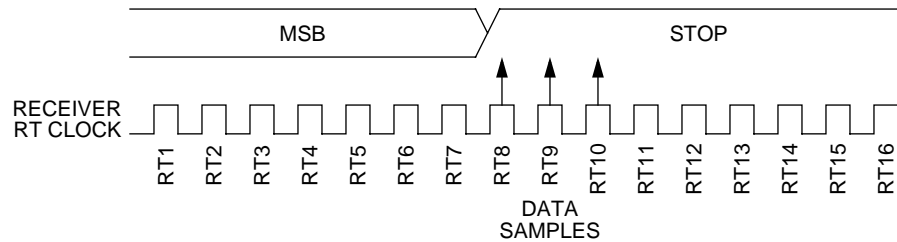

Figure 75 Slow Data

For an 8-bit data character, data sampling of the stop bit takes the receiver 9 bit times x 16 RT cycles + 10 RT cycles = 154 RT cycles.

With the misaligned character shown in Figure 75, the receiver counts 154 RT cycles at the point when the count of the transmitting device is 9 bit times x 16 RT cycles + 3 RT cycles = 147 RT cycles.

The maximum percent difference between the receiver count and the transmitter count of a slow 8-bit data character with no errors is:

$$((154 - 147) / 154) \times 100 = 4.54\%$$

For a 9-bit data character, data sampling of the stop bit takes the receiver 10 bit times x 16 RT cycles + 10 RT cycles = 170 RT cycles.

With the misaligned character shown in Figure 75, the receiver counts 170 RT cycles at the point when the count of the transmitting device is 10 bit times x 16 RT cycles + 3 RT cycles = 163 RT cycles.

The maximum percent difference between the receiver count and the transmitter count of a slow 9-bit character with no errors is:

$$((170 - 163) / 170) \times 100 = 4.12\%$$

*Fast Data
Tolerance*

Figure 76 shows how much a fast received frame can be misaligned. The fast stop bit ends at RT10 instead of RT16 but is still sampled at RT8, RT9, and RT10.

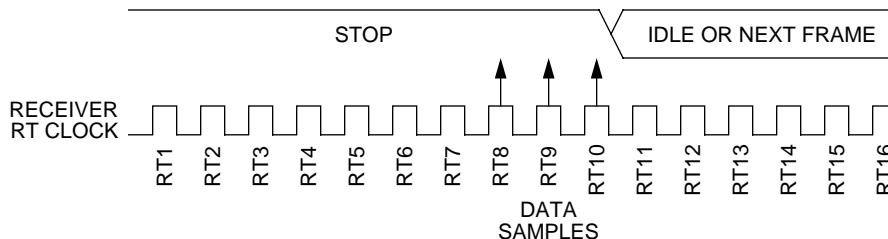

Figure 76 Fast Data

For an 8-bit data character, data sampling of the stop bit takes the receiver 9 bit times x 16 RT cycles + 10 RT cycles = 154 RT cycles.

With the misaligned character shown in Figure 76, the receiver counts 154 RT cycles at the point when the count of the transmitting device is 10 bit times x 16 RT cycles = 160 RT cycles.

The maximum percent difference between the receiver count and the transmitter count of a fast 8-bit character with no errors is:

$$((154 - 160) / 154) \times 100 = 3.90\%$$

For a 9-bit data character, data sampling of the stop bit takes the receiver 10 bit times x 16 RT cycles + 10 RT cycles = 170 RT cycles.

With the misaligned character shown in Figure 76, the receiver counts 170 RT cycles at the point when the count of the transmitting device is 11 bit times x 16 RT cycles = 176 RT cycles.

The maximum percent difference between the receiver count and the transmitter count of a fast 9-bit character with no errors is:

$$((170 - 176) / 170) \times 100 = 3.53\%$$

Receiver Wakeup

To enable the SCI to ignore transmissions intended only for other receivers in multiple-receiver systems, the receiver can be put into a standby state. Setting the receiver wakeup bit, RWU, in SCI control register 2 (SCICR2) puts the receiver into a standby state during which

Serial Communications Interface (SCI)

receiver interrupts are disabled. The SCI will still load the receive data into the SCIDRH/L registers, but it will not set the RDRF flag.

The transmitting device can address messages to selected receivers by including addressing information in the initial frame or frames of each message.

The WAKE bit in SCI control register 1 (SCICR1) determines how the SCI is brought out of the standby state to process an incoming message. The WAKE bit enables either idle line wakeup or address mark wakeup.

*Idle input line
wakeup
(WAKE = 0)*

In this wakeup method, an idle condition on the **sci_rx_ind** signal clears the RWU bit and wakes up the SCI. The initial frame or frames of every message contain addressing information. All receivers evaluate the addressing information, and receivers for which the message is addressed process the frames that follow. Any receiver for which a message is not addressed can set its RWU bit and return to the standby state. The RWU bit remains set and the receiver remains on standby until another idle character appears on the **sci_rx_ind** signal.

Idle line wakeup requires that messages be separated by at least one idle character and that no message contains idle characters.

The idle character that wakes a receiver does not set the receiver idle bit, IDLE, or the receive data register full flag, RDRF.

The idle line type bit, ILT, determines whether the receiver begins counting logic 1s as idle character bits after the start bit or after the stop bit. ILT is in SCI control register 1 (SCICR1).

*Address mark
wakeup
(WAKE = 1)*

In this wakeup method, a logic 1 in the most significant bit (msb) position of a frame clears the RWU bit and wakes up the SCI. The logic 1 in the msb position marks a frame as an address frame that contains addressing information. All receivers evaluate the addressing information, and the receivers for which the message is addressed process the frames that follow. Any receiver for which a message is not addressed can set its RWU bit and return to the standby state. The RWU bit remains set and the receiver remains on standby until another address frame appears on the **sci_rx_ind** signal.

The logic 1 msb of an address frame clears the receiver's RWU bit before the stop bit is received and sets the RDRF flag.

Address mark wakeup allows messages to contain idle characters but requires that the msb be reserved for use in address frames.

NOTE: *With the WAKE bit clear, setting the RWU bit after the **sci_rx_ind** signal has been idle can cause the receiver to wake up immediately.*

Single-Wire Operation

Normally, the SCI uses two pins for transmitting and receiving. In single-wire operation, the RXD pin is disconnected from the SCI. The SCI uses the TXD pin for both receiving and transmitting.

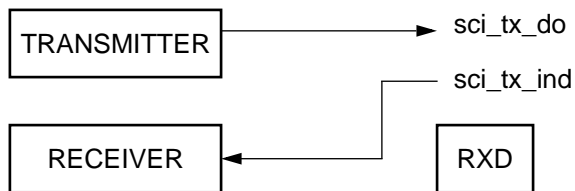

Figure 77 Single-Wire Operation (LOOPS = 1, RSRC = 1)

Enable single-wire operation by setting the LOOPS bit and the receiver source bit, RSRC, in SCI control register 1 (SCICR1). Setting the LOOPS bit disables the path from the **sci_rx_ind** signal to the receiver. Setting the RSRC bit connects the receiver input to the output of the TXD pin driver. Both the transmitter and receiver must be enabled (TE=1 and RE=1). The TXDIR bit (SCISR2[1]) determines whether the TXD pin is going to be used as an input (TXDIR = 0) or an output (TXDIR = 1) in this mode of operation.

Loop Operation

In loop operation the transmitter output goes to the receiver input. The **sci_rx_ind** signal is disconnected from the SCI.

Serial Communications Interface (SCI)

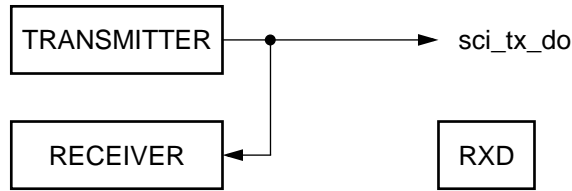

Figure 78 Loop Operation (LOOPS = 1, RSRC = 0)

Enable loop operation by setting the LOOPS bit and clearing the RSRC bit in SCI control register 1 (SCICR1). Setting the LOOPS bit disables the path from the **sci_rx_ind** signal to the receiver. Clearing the RSRC bit connects the transmitter output to the receiver input. Both the transmitter and receiver must be enabled (TE = 1 and RE = 1).

Modes of Operation

Run Mode Normal mode of operation.

Wait Mode SCI operation in wait mode depends on the state of the SCISWAI bit in the SCI control register 1 (SCICR1).

- If SCISWAI is clear, the SCI operates normally when the CPU is in wait mode.
- If SCISWAI is set, SCI clock generation ceases and the SCI module enters a power-conservation state when the CPU is in wait mode. Setting SCISWAI does not affect the state of the receiver enable bit, RE, or the transmitter enable bit, TE.

If SCISWAI is set, any transmission or reception in progress stops at wait mode entry. The transmission or reception resumes when either an internal or external interrupt brings the CPU out of wait mode. Exiting wait mode by reset aborts any transmission or reception in progress and resets the SCI.

Stop Mode

The SCI is inactive during stop mode for reduced power consumption. The STOP instruction does not affect the SCI register states, but the SCI module clock will be disabled. The SCI operation resumes from where it left off after an external interrupt brings the CPU out of stop mode. Exiting stop mode by reset aborts any transmission or reception in progress and resets the SCI.

Interrupt Operation

Recovery from Wait Mode

The SCI interrupt request can be used to bring the CPU out of wait mode.

System Level Interrupt Sources

This section describes the interrupt originated by the SCI block. The MCU must service the interrupt requests. [Table 73](#) lists the five interrupt sources of the SCI. The local enables for the five SCI interrupt sources, are described in [Table 73](#).

Table 73 SCI Interrupt Sources

Interrupt	Source	Description
TDRE	SCISR1[7]	Active high level detect. Indicates that a byte was transferred from SCIDRH/L to the transmit shift register.
TC	SCISR1[6]	Active high level detect. Indicates that a transmit is complete.
RDRF	SCISR1[5]	Active high level detects. The RDRF interrupt indicates that received data is available in the SCI data register.
OR	SCISR1[3]	Active high level detects. This interrupt indicates that an overrun condition has occurred.
IDLE	SCISR1[4]	Active high level detect. Indicates that receiver input has become idle.

The SCI only originates interrupt requests. The following is a description of how the SCI makes a request and how the MCU should acknowledge that request. The interrupt vector offset and interrupt number are chip dependent. The SCI only has a single interrupt line (**sci_int**, active high

Serial Communications Interface (SCI)

operation) and all the following interrupts, when generated, are ORed together and issued through that port.

<i>TDRE Description</i>	The TDRE interrupt is set high by the SCI when the transmit shift register receives a byte from the SCI data register. A TDRE interrupt indicates that the transmit shift register (SCIDRH/L) is empty and that a new byte can be written to the SCIDRH/L for transmission. Clear TDRE by reading SCI status register 1 with TDRE set and then writing to SCI data register low (SCIDRL).
<i>TC Description</i>	The TC interrupt is set by the SCI when a transmission has been completed. A TC interrupt indicates that there is no transmission in progress. TC is set high when the TDRE flag is set and no data, preamble, or break character is being transmitted. When TC is set, the TXD pin becomes idle (logic 1). Clear TC by reading SCI status register 1 (SCISR1) with TC set and then writing to SCI data register low (SCIDRL). TC is cleared automatically when data, preamble, or break is queued and ready to be sent.
<i>RDRF Description</i>	The RDRF interrupt is set when the data in the receive shift register transfers to the SCI data register. A RDRF interrupt indicates that the received data has been transferred to the SCI data register and that the byte can now be read by the MCU. The RDRF interrupt is cleared by reading the SCI status register one (SCISR1) and then reading SCI data register low (SCIDRL).
<i>OR Description</i>	The OR interrupt is set when software fails to read the SCI data register before the receive shift register receives the next frame. The newly acquired data in the shift register will be lost in this case, but the data already in the SCI data registers is not affected. The OR interrupt is cleared by reading the SCI status register one (SCISR1) and then reading SCI data register low (SCIDRL).
<i>IDLE Description</i>	The IDLE interrupt is set when 10 consecutive logic 1s (if M=0) or 11 consecutive logic 1s (if M=1) appear on the receiver input. Once the IDLE is cleared, a valid frame must again set the RDRF flag before an



Freescale Semiconductor, Inc.

Serial Communications Interface (SCI)
Interrupt Operation

idle condition can set the IDLE flag. Clear IDLE by reading SCI status register 1 (SCISR1) with IDLE set and then reading SCI data register low (SCIDRL).



Serial Peripheral Interface (SPI)

Contents

Overview	429
Features	430
Modes of Operation	430
Block Diagram	431
Signal Descriptions	432
Module Memory Map	436
Register Quick Reference	437
Register Descriptions	438
Functional Description	446
Low Power Mode Options	457
Errata	459
Reset	460
Interrupts	460

Overview

The Serial Peripheral Interface module allows full-duplex, synchronous, serial communication between the MCU and peripheral devices. Software can poll the SPI status flags or the SPI operation can be interrupt driven

Serial Peripheral Interface (SPI)

Features

The Serial Peripheral Interface includes these distinctive features:

- Master mode and slave mode
- Bi-directional mode
- Slave select output
- Mode fault error flag with CPU interrupt capability
- Double-buffered operation
- Serial clock with programmable polarity and phase
- Control of SPI operation during wait mode

Modes of Operation

The SPI functions in three modes, run, wait, and stop.

- Run Mode
This is the basic mode of operation.
- Wait Mode
SPI operation in wait mode is a configurable low power mode. Depending on the state of internal bits, the SPI can operate normally when the CPU is in wait mode or the SPI clock generation can be turned off and the SPI module enters a power conservation state during wait mode. During wait mode, any master transmission in progress stops. Reception and transmission of a byte as slave continues so that the slave is synchronized to the master.
- Stop Mode
The SPI is inactive in stop mode for reduced power consumption. The STOP instruction does not affect or depend on SPI register states. Again, reception and transmission of a byte as slave continues to stay synchronized with the master.

This is a high level description only, detailed descriptions of operating modes are contained in section [Low Power Mode Options](#).

Block Diagram

Figure 79 is a block diagram of the Serial Peripheral Interface.

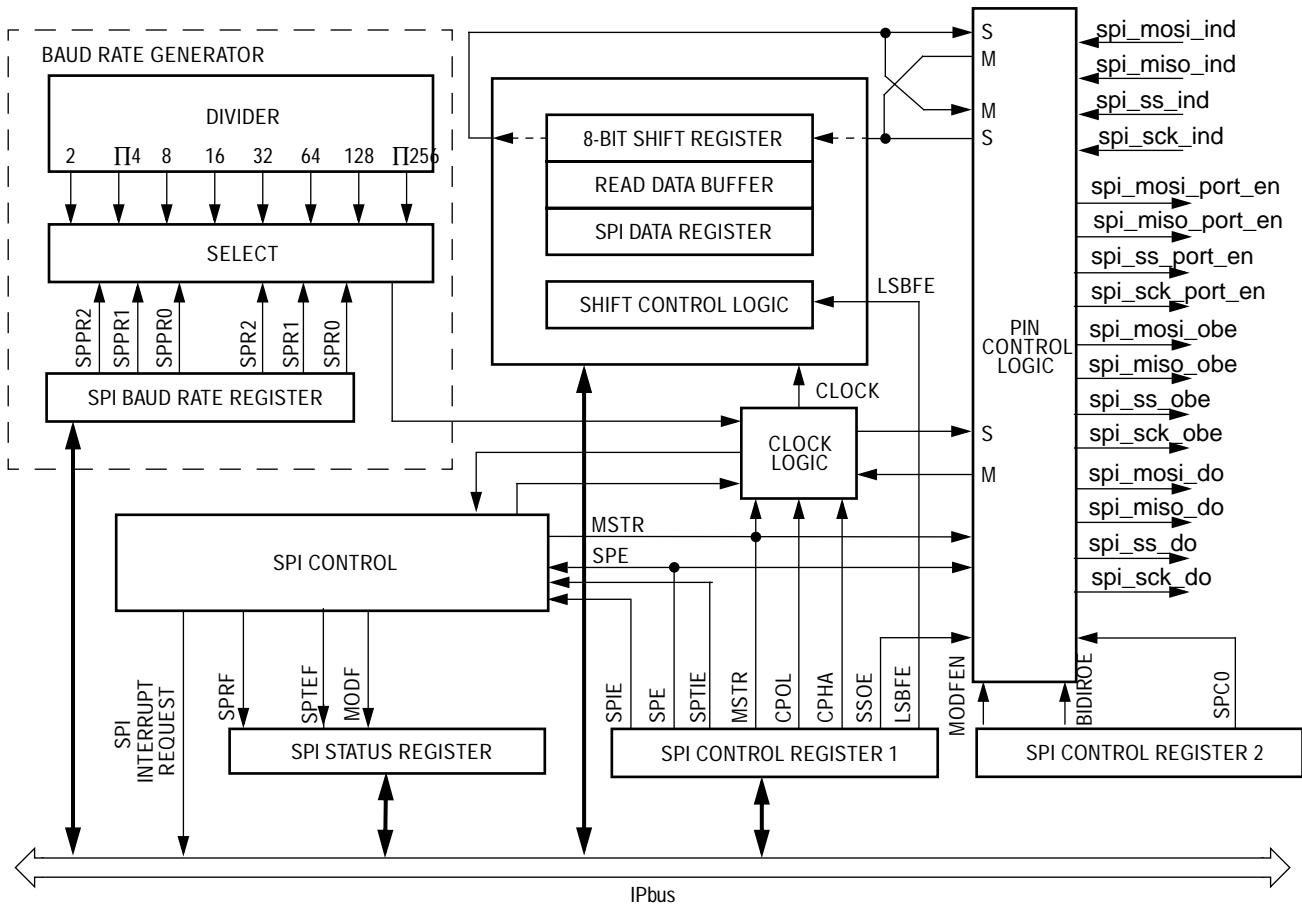

Figure 79 SPI Block Diagram

Serial Peripheral Interface (SPI)
Signal Descriptions

Table 74 summarizes the Serial Peripheral Interface pad interface signal characteristics.

Table 74 SPI Pad Interface Signal Characteristics

Signal Name	Mnemonic	Input/Output	Active State	Reset State	Function
Input Signals					
Slave Data in	spi_mosi_ind	Input	—	—	Input mosi port from SPI Pads
Master Data in	spi_miso_ind	Input	—	—	Input miso port from SPI Pads
Slave Select in	spi_ss_ind	Input	Low	—	Input slave select port from SPI Pads
Serial Clock in	spi_sck_ind	Input	High Low	—	Input serial clock from SPI Pads
Control Signals					
MOSI port enable	spi_mosi_port_en	Output	High		Indicates that the SPI is the master of the pad.
MISO port enable	spi_miso_port_en	Output	High		Indicates that the SPI is the master of the pad.
\overline{SS} port enable	spi_ss_port_en	Output	High		Indicates that the SPI is the master of the pad.
SCK port enable	spi_sck_port_en	Output	High		Indicates that the SPI is the master of the pad.
MOSI Output enable	spi_mosi_obe	Output	High		Indicates that the output buffer should be turned on, so the SPI pin value is driving the wire.
MISO Output enable	spi_miso_obe	Output	High		Indicates that the output buffer should be turned on, so the SPI pin value is driving the wire.
\overline{SS} Output enable	spi_ss_obe	Output	High		Indicates that the output buffer should be turned on, so the SPI pin value is driving the wire.
SCK Output enable	spi_sck_obe	Output	High		Indicates that the output buffer should be turned on, so the SPI pin value is driving the wire.
Output Signals					
Master Data out	spi_mosi_do	Output	—	—	Output mosi port to SPI Pads
Slave Data out	spi_miso_do	Output	—	—	Output miso port to SPI Pads
Slave Select out	spi_ss_do	Output	—	—	Output ss port to SPI Pads
Serial Clock out	spi_sck_do	Output	—	—	Output sck port to SPI Pads

Basically four signals are used in the following configuration (Refer to [Figure 80](#)) to generate each of the ports MISO, MOSI, SCK and \overline{SS} .

Figure 80 SPI External Interface

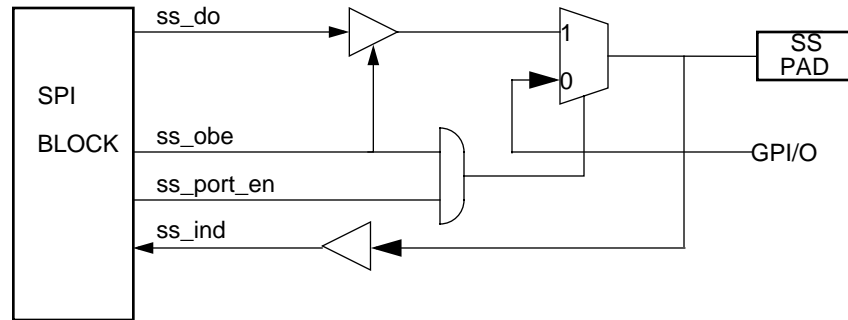

Pad Input Signals

- Slave Data in (spi_mosi_ind)* This is one of the two SPI module pins that transmit serial data. This pin is accepted as an input by the SPI when the SPI is configured as a slave.
- Master Data in (spi_miso_ind)* This is one of the two SPI module pins that transmit serial data. This pin is accepted as an input by the SPI when the SPI is configured as a master.
- Slave Select in (spi_ss_ind)* This pin is used to indicate that the SPI module has been selected for data transfer. This pin is always accepted as an input by the SPI when the SPI is configured as a slave.
- Serial Clock in (spi_sck_ind)* This pin is used as the clock with respect to which the data is accepted.

Pad Control Signals

- Mosi port enable (mosi_port_en)* This pin indicates that the SPI is the master of the MOSI pad.

Serial Peripheral Interface (SPI)

Normally this signal is asserted when the SPE bit of the SPICR1 register is set. Also, when configured in Slave mode and in Bidirectional mode of operation, this signal is de-asserted.

*Miso port enable
(miso_port_en)*

This pin indicates that the SPI is the master of the MISO pad.

Normally this signal is asserted when the SPE bit of the SPICR1 register is set. Also, when configured in Master mode and in Bidirectional mode of operation, this signal is de-asserted.

*SS port enable
(ss_port_en)*

This pin indicates that the SPI is the master of the SS pad.

Normally this signal is asserted when the SPE bit of the SPICR1 register is set. When configured in Master mode and MODFEN bit of SPICR2 is cleared, then this signal is de-asserted.

*Sck port enable
(sck_port_en)*

This pin indicates that the SPI is the master of the SCK pad. Normally this signal is asserted when the SPE bit of the SPICR1 register is set.

*Mosi port output
enable
(mosi_obe)*

This pin indicates that the MOSI output buffer is enabled if mosi_port_en was set.

If the bidirectional serial pin mode is selected in the master, MOSI becomes MOMI (master out/master in) and the direction is controlled by the BIDIROE bit 3 of the SPI control register 2.

*Miso port output
enable
(miso_obe)*

This pin indicates that the MISO output buffer is enabled if miso_port_en was set.

If the bidirectional serial pin mode is selected in the slave, MISO becomes SISO (slave in/slave out) and the direction is controlled by the BIDIROE bit 3 of the SPI control register 2.

*SS port output
enable (ss_obe)*

This pin indicates that the SS output buffer is enabled if ss_port_en was set.

SCK port output enable (sck_obe) This pin indicates that the SCK output buffer is enabled if sck_port_en was set.

Output Signals

Master Data out (spi_mosi_do) This pin is used to transmit data out of the SPI module when it is configured as a Master.

Slave Data out (spi_miso_do) This pin is used to transmit data out of the SPI module when it is configured as a Slave.

Slave select out (spi_ss_do) This pin is used to output the select signal from the SPI module to another peripheral with which a data transfer is to take place.

Serial Clock out (spi_sck_do) This pin is used to output the clock with respect to which the SPI transfers data.

Module Memory Map

The memory map for the Serial Peripheral Interface is given below in [Table 75](#). The address listed for each register is the sum of a base address and an address offset. The base address is defined at the SoC level and the address offset is defined at the module level. Reads from reserved addresses (\$0006 through \$0007 and \$0004) return zeros and writes to reserved addresses have no effect.

Table 75 Module Memory Map

Address	Use	Access
\$0000	SPI Control Register 1	Read / Write
\$0001	SPI Control Register 2	Read / Write ⁽¹⁾
\$0002	SPI Baud Rate Register	Read / Write ⁽¹⁾
\$0003	SPI Status Register	Read ⁽²⁾
\$0004	Reserved	--- ⁽²⁾ ⁽³⁾
\$0005	SPI Data Register	Read / Write
\$0006	Reserved	--- ⁽²⁾ ⁽³⁾
\$0007	Reserved	--- ⁽²⁾ ⁽³⁾

1. Certain bits are non-writable.
2. Writes to this register are ignored.
3. Reading from this register returns all zeros.

Register Quick Reference

Register Name	Bit 7	6	5	4	3	2	1	Bit 0	Address Offset	
SPICR1	R W	SPIE	SPE	SPTIE	MSTR	CPOL	CPHA	SSOE	LSBFE	\$0000
SPICR2	R W	0	0	0	MODFEN	BIDIROE	0	SPISWAI	SPC0	\$0001
SPIBR	R W	0	SPPR2	SPPR1	SPPR0	0	SPR2	SPR1	SPR0	\$0002
SPISR	R W	SPRF	0	SPTEF	MODF	0	0	0	0	\$0003
SPI Reserved	R W	0	0	0	0	0	0	0	0	\$0004
SPIDR	R W	Bit 7	6	5	4	3	2	1	Bit 0	\$0005
SPI Reserved	R W	0	0	0	0	0	0	0	0	\$0006
SPI Reserved	R W	0	0	0	0	0	0	0	0	\$0007

= Unimplemented or Reserved

Figure 81 SPI Register Summary

Serial Peripheral Interface (SPI)

Register Descriptions

This section consists of register descriptions in address order. Each description includes a standard register diagram with an associated figure number. Details of register bit and field function follow the register diagrams, in bit order.

SPI Control
Register 1 (SPICR1)

Address Offset: \$0000

	Bit 7	6	5	4	3	2	1	Bit 0
R	SPIE	SPE	SPTIE	MSTR	CPOL	CPHA	SSOE	LSBFE
W								
Reset:	0	0	0	0	0	1	0	0

Read: anytime

Write: anytime

SPIE — SPI Interrupt Enable Bit

This bit enables SPI interrupts each time the SPIF or MODF status flag is set.

1 = SPI interrupts enabled.

0 = SPI interrupts disabled.

SPE — SPI System Enable Bit

This bit enables the SPI system and dedicates the SPI port pins to SPI system functions. When SPE is clear, the SPI system is initialized but in a low-power disabled state.

1 = SPI port pins are dedicated to SPI functions.

0 = SPI system is in a low-power, disabled state.

SPTIE — SPI Transmit Interrupt Enable

This bit enables SPI interrupt generated each time the SPTEF flag is set.

1 = SPTEF interrupt enabled.

0 = SPTEF interrupt disabled.

MSTR — SPI Master/Slave Mode Select Bit

- 1 = Master mode
- 0 = Slave mode

CPOL — SPI Clock Polarity Bit

This bit selects an inverted or non-inverted SPI clock. To transmit data between SPI modules, the SPI modules must have identical CPOL values.

- 1 = Active-low clocks selected; SCK idles high
- 0 = Active-high clocks selected; SCK idles low

CPHA — SPI Clock Phase Bit

This bit is used to shift the SCK serial clock.

- 1 = The first SCK edge is issued at the beginning of the 8-cycle transfer operation
- 0 = The first SCK edge is issued one-half cycle into the 8-cycle transfer operation

SSOE — Slave Select Output Enable

The SS output feature is enabled only in the master mode by asserting the SSOE as shown in [Table 76](#).

Table 76 \overline{SS} Input / Output Selection

MOD FEN	SSOE	Master Mode	Slave Mode
0	0	----	\overline{SS} input
0	1	----	\overline{SS} input
1	0	\overline{SS} input with MODF feature	\overline{SS} input
1	1	\overline{SS} output	\overline{SS} input

LSBFE — SPI LSB-First Enable

This bit does not affect the position of the msb and lsb in the data register. Reads and writes of the data register always have the msb in bit 7.

- 1 = Data is transferred least significant bit first.
- 0 = Data is transferred most significant bit first.

Serial Peripheral Interface (SPI)

SPI Control

Register 2 (SPICR2)

Address Offset: \$0001

	Bit 7	6	5	4	3	2	1	Bit 0
R	0	0	0	MODFEN	BIDIROE	0	SPISWAI	SPC0
W								
Reset:	0	0	0	0	0	0	0	0

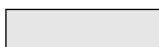

= Unimplemented or Reserved

Read: anytime

Write: anytime; writes to unimplemented bits have no effect

MODFEN — Mode Fault Enable Bit

This bit when set allows the MODF flag to be set. If the MODF flag is set, clearing the MODFEN does not clear the MODF flag. If the SPI is enabled as master and the MODFEN bit is low, then the \overline{SS} is available as a general purpose I/O.

When the SPI is enabled as a slave, the \overline{SS} is available only as an input regardless of the value of MODFEN.

- 1 = Enable setting the MODF error
- 0 = Disable the MODF error

BIDIROE — Output enable in the Bidirectional mode of operation

This bit along with the MSTR bit of SPCR1 is used to enable the output buffer when the SPI is configured in bidirectional mode.

- 1 = Output buffer enabled
- 0 = Output buffer disabled

SPISWAI — SPI Stop in Wait Mode Bit

This bit is used for power conservation while in wait mode.

- 1 = Stop SPI clock generation when in wait mode
- 0 = SPI clock operates normally in wait mode

SPC0 — Serial Pin Control Bit 0

With the MSTR control bit, this bit enables bidirectional pin configurations as shown in [Table 77](#).

Table 77 Bidirectional Pin Configurations

Pin Mode		SPC0	MSTR	MISO (1)	MOSI (2)	SCK (3)	\overline{SS} (4)
A	Normal	0	0	Slave Out	Slave In	SCK in	\overline{SS} in
B			1	Master In	Master Out	SCK out	\overline{SS} I/O
C	Bidirectional	1	0	Slave I/O	---	SCK in	\overline{SS} In
D			1	---	Master I/O	SCK out	\overline{SS} I/O

1. Slave output is enabled if BIDIROE bit = 1, \overline{SS} = 0, and MSTR = 0 (C)
2. Master output is enabled if BIDIROE bit = 1 and MSTR = 1 (D)
3. SCK output is enabled if MSTR = 1 (B, D)
4. \overline{SS} output is enabled if MODFEN bit = 1, SSOE = 1, and MSTR = 1 (B, D).

SPI Baud Rate Register (SPIBR)

Address Offset: \$0002

	Bit 7	6	5	4	3	2	1	Bit 0
R	0	SPPR2	SPPR1	SPPR0	0	SPR2	SPR1	SPR0
W								
Reset:	0	0	0	0	0	0	0	0

= Unimplemented or Reserved

Read: anytime

Write: anytime; writes to unimplemented bits have no effect

NOTE: *Writing to this register during data transfers may cause spurious results*

SPPR2–SPPR0 — SPI Baud Rate Preselection Bits

SPR2–SPR0 — SPI Baud Rate Selection Bits

These bits specify the SPI baud rates as shown in the table below

The baud rate divisor equation is as follows

$$\text{BaudRateDivisor} = (\text{SPPR} + 1) \cdot 2^{(\text{SPR} + 1)}$$



Serial Peripheral Interface (SPI)

Table 78 SPI Baud Rate Selection (25 MHz Module Clock)

SPPR2	SPPR1	SPPR0	SPR2	SPR1	SPR0	SPI Module Clock Divisor	Baud Rate
0	0	0	0	0	0	2	12.5 MHz
0	0	0	0	0	1	4	6.25 MHz
0	0	0	0	1	0	8	3.125 MHz
0	0	0	0	1	1	16	1.56 MHz
0	0	0	1	0	0	32	781.25 KHz
0	0	0	1	0	1	64	390.63 kHz
0	0	0	1	1	0	128	195.31 kHz
0	0	0	1	1	1	256	97.69 kHz
0	0	1	0	0	0	4	6.25 Mhz
0	0	1	0	0	1	8	3.13 MHz
0	0	1	0	1	0	16	1.56 MHz
0	0	1	0	1	1	32	781.25 KHz
0	0	1	1	0	0	64	390.63 kHz
0	0	1	1	0	1	128	195.31 kHz
0	0	1	1	1	0	256	97.69 kHz
0	0	1	1	1	1	512	48.81 kHz
0	1	0	0	0	0	6	4.17 MHz
0	1	0	0	0	1	12	2.08 MHz
0	1	0	0	1	0	24	1.04 MHz
0	1	0	0	1	1	48	520.81 kHz
0	1	0	1	0	0	96	260.44 kHz
0	1	0	1	0	1	192	130.25 kHz
0	1	0	1	1	0	384	65.13 kHz
0	1	0	1	1	1	768	32.56 kHz
0	1	1	0	0	0	8	3.13 MHz
0	1	1	0	0	1	16	1.56 MHz
0	1	1	0	1	0	32	781.25 KHz
0	1	1	0	1	1	64	390.63 kHz
0	1	1	1	0	0	128	195.31 kHz
0	1	1	1	0	1	256	97.69 kHz
0	1	1	1	1	0	512	48.81 kHz
0	1	1	1	1	1	1024	24.44 kHz
1	0	0	0	0	0	10	2.5 MHz
1	0	0	0	0	1	20	1.25 MHz
1	0	0	0	1	0	40	625 KHz
1	0	0	0	1	1	80	312.5 kHz

Table 78 SPI Baud Rate Selection (25 MHz Module Clock)

SPPR2	SPPR1	SPPR0	SPR2	SPR1	SPR0	SPI Module Clock Divisor	Baud Rate
1	0	0	1	0	0	160	156.25 kHz
1	0	0	1	0	1	320	78.13 kHz
1	0	0	1	1	0	640	39.06 kHz
1	0	0	1	1	1	1280	20.19 kHz
1	0	1	0	0	0	12	2.08 MHz
1	0	1	0	0	1	24	1.04 MHz
1	0	1	0	1	0	48	520.81 kHz
1	0	1	0	1	1	96	260.44 kHz
1	0	1	1	0	0	192	130.25 kHz
1	0	1	1	0	1	384	65.13 kHz
1	0	1	1	1	0	768	32.56 kHz
1	0	1	1	1	1	1536	16.25 kHz
1	1	0	0	0	0	14	1.79 MHz
1	1	0	0	0	1	28	893.75 KHz
1	1	0	0	1	0	56	446.44 kHz
1	1	0	0	1	1	112	223.19 kHz
1	1	0	1	0	0	224	111.63 kHz
1	1	0	1	0	1	448	55.81 kHz
1	1	0	1	1	0	896	27.88 kHz
1	1	0	1	1	1	1792	13.94 kHz
1	1	1	0	0	0	16	1.56 MHz
1	1	1	0	0	1	32	781.25 KHz
1	1	1	0	1	0	64	390.63 kHz
1	1	1	0	1	1	128	195.31 kHz
1	1	1	1	0	0	256	97.69 kHz
1	1	1	1	0	1	512	48.81 kHz
1	1	1	1	1	0	1024	24.44 kHz
1	1	1	1	1	1	2048	12.19 kHz

NOTE: For consecutive transmissions, the Baud rate selected should be less than $\text{Module Clock}/4$. If consecutive transmissions are attempted at a rate greater than or equal to $\text{Module Clock}/4$, it could lead to reception of corrupt data.

Serial Peripheral Interface (SPI)

SPI Status Register (SPISR)

Address Offset: \$0003

	Bit 7	6	5	4	3	2	1	Bit 0
R	SPRF	0	SPTEF	MODF	0	0	0	0
W								
Reset:	0	0	1	0	0	0	0	0

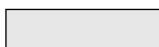

= Unimplemented or Reserved

Read: anytime

Write: has no meaning or effect

SPRF — SPRF Receive Interrupt Flag

This bit is set after the eighth SCK cycle in a data transfer and is cleared by reading the SPISR register (with SPIF set) followed by a read access to the SPI data register.

1 = New data Copied to SPIDR

0 = Transfer not yet complete

SPTEF — SPI Transmit Empty Interrupt Flag

This bit is set each time the transmit data register transfers a byte into the shift register. SPTEF generates an SPTEF CPU interrupt request if the SPTIE bit in the SPICR1 is also set. This bit is cleared by reading the SPISR register (with SPTEF set) followed by a write access to the SPI data register. For an idle master or idle slave that has no data loaded into its transmit buffer, the SPTEF will be set again within two bus cycles since the transmit buffer empties into the shift register. This allows the user to queue up 16-bit value to send. For an already active slave, the load of the shift register cannot occur until the transmission is complete. The SPTEF indicates when the next write can occur

1 = SPI Data register empty

0 = SPI Data register not empty

MODF — Mode Fault Flag

This bit is set if the \overline{SS} input becomes low while the SPI is configured as a master. The flag is cleared automatically by a read of the SPI status register (with MODF set) followed by a write to the SPI control register 1. The MODF flag is set only if the MODFEN bit of SPICR2 register is set, Refer to MODFEN bit description in [SPI Control Register 2 \(SPICR2\)](#).

- 1 = Mode fault has occurred.
- 0 = Mode fault has not occurred.

SPI Data Register (SPIDR)

Address Offset: \$0005

	Bit 7	6	5	4	3	2	1	Bit 0
R	Bit 7	6	5	4	3	2	2	Bit 0
W	Bit 7	6	5	4	3	2	2	Bit 0
Reset:	0	0	0	0	0	0	0	0

Read: anytime; normally read only after SPIF is set
Write: anytime; see SPTEF

The SPI Data register is both the input and output register for SPI data. A write to this register allows a data byte to be queued and transmitted. For a SPI configured as a master, a queued data byte is transmitted immediately after the previous transmission has completed. The SPI Transmitter empty flag in SPISR indicates when the SPI data register is ready to accept new data.

NOTE: *Do not write to the SPI data register unless the SPTEF bit is high.*

Reading the data can occur anytime from after the SPIF is set to before the end of the next transfer. If the SPIF is not serviced by the end of the successive transfers, those data bytes are lost and the data within the SPIDR retains the first byte until SPIF is serviced.

Functional Description

The SPI module allows full-duplex, synchronous, serial communication between the MCU and peripheral devices. Software can poll the SPI status flags or SPI operation can be interrupt driven.

The SPI system is enabled by setting the SPI enable (SPE) bit in SPI control register 1. While SPE is set, the four associated SPI port pins are dedicated to the SPI function as:

- Slave select (\overline{SS})
- Serial clock (SCK)
- Master out/slave in (MOSI)
- Master in/slave out (MISO)

The main element of the SPI system is the SPI data register. The 8-bit data register in the master and the 8-bit data register in the slave are linked by the MOSI and MISO pins to form a distributed 16-bit register. When a data transfer operation is performed, this 16-bit register is serially shifted eight bit positions by the SCK clock from the master; data is exchanged between the master and the slave. Data written to the master SPI data register becomes the output data for the slave, and data read from the master SPI data register after a transfer operation is the input data from the slave.

A write to the SPI data register puts data into the transmit buffer if the previous transmission was complete. When a transfer is complete, received data is moved into a receive data register. Data may be read from this double-buffered system any time before the next transfer is complete. This 8-bit data register acts as the SPI receive data register for reads and as the SPI transmit data register for writes. A single SPI register address is used for reading data from the read data buffer and for writing data to the shifter.

The clock phase control bit (CPHA) and a clock polarity control bit (CPOL) in the SPI control register 1 select one of four possible clock formats to be used by the SPI system. The CPOL bit simply selects a non-inverted or inverted clock. The CPHA bit is used to accommodate

two fundamentally different protocols by shifting the clock by a half cycle or by not shifting the clock (see [Transmission Formats](#)).

The SPI can be configured to operate as a master or as a slave. When MSTR in SPI control register1 is set, the master mode is selected; when the MSTR bit is clear, the slave mode is selected.

Master Mode

The SPI operates in master mode when the MSTR bit is set. Only a master SPI module can initiate transmissions. A transmission begins by writing to the master SPI data register. If the shift register is empty, the byte immediately transfers to the shift register. The byte begins shifting out on the MOSI pin under the control of the serial clock.

The SPR2, SPR1, and SPR0 baud rate selection bits in conjunction with the SPPR2, SPPR1, and SPPR0 baud rate preselection bits in the SPI baud rate register control the baud rate generator and determine the speed of the shift register. The SCK pin is the SPI clock output. Through the SCK pin, the baud rate generator of the master controls the shift register of the slave peripheral.

Consecutive transmissions are possible but care should be taken to set the Baud rate selection bits to correspond to a frequency less than $\text{busclock}/4$.

In master mode, the function of the serial data output pin (MOSI) and the serial data input pin (MISO) is determined by the SPC0 and MSTR control bits.

The $\overline{\text{SS}}$ pin is normally an input which should remain in the inactive high state. However, in the master mode, if both MODFEN bit and SSOE bit are set, then the $\overline{\text{SS}}$ pin is the slave select output.

The $\overline{\text{SS}}$ output becomes low during each transmission and is high when the SPI is in the idling state. If the $\overline{\text{SS}}$ input becomes low while the SPI is configured as a master, it indicates a mode fault error where more than one master may be trying to drive the MOSI and SCK lines simultaneously. In this case, the SPI immediately clears the output buffer enables associated with the MISO, MOSI (or MOMI), and SCK pins so that these pins become inputs. This mode fault error also clears the SPE and MSTR control bits and sets the mode fault (MODF) flag in the SPI

Serial Peripheral Interface (SPI)

status register. If the SPI interrupt enable bit (SPIE) is set when the MODF bit gets set, then an SPI interrupt sequence is also requested

When a write to the SPI data register in the master occurs, there is a half SCK-cycle delay. After the delay, SCK is started within the master. The rest of the transfer operation differs slightly, depending on the clock format specified by the SPI clock phase bit, CPHA, in SPI control register 1 (see [Transmission Formats](#)).

Slave Mode

The SPI operates in slave mode when the MSTR bit in SPI control register 1 is clear. In slave mode, SCK is the SPI clock input from the master, and \overline{SS} is the slave select input. Before a data transmission occurs, the \overline{SS} pin of the slave SPI must be at logic 0. \overline{SS} must remain low until the transmission is complete.

In slave mode, the function of the serial data output pin (MISO) and serial data input pin (MOSI) is determined by the SPC0 bit in SPI control register 2 and the MSTR control bit. While in slave mode, the \overline{SS} input controls the serial data output pin; if \overline{SS} is high (not selected), the serial data output pin is high impedance, and, if \overline{SS} is low the first bit in the SPI data register is driven out of the serial data output pin. Also, if the slave is not selected (\overline{SS} is high), then the SCK input is ignored and no internal shifting of the SPI shift register takes place.

Although the SPI is capable of full-duplex operation, some SPI peripherals are capable of only receiving SPI data in a slave mode. For these simpler devices, there is no serial data out pin.

NOTE: *When peripherals with full-duplex capability are used, take care not to simultaneously enable two receivers whose serial outputs drive the same system slave's serial data output line.*

As long as no more than one slave device drives the system slave's serial data output line, it is possible for several slaves to receive the same transmission from a master, although the master would not receive return information from all of the receiving slaves.

If the CPHA bit in SPI control register 1 is clear, odd numbered edges on the SCK input cause the data at the serial data input pin to be latched.

Even numbered edges cause the value previously latched from the serial data input pin to shift into the LSB of the SPI shifter.

If the CPHA bit is set, even numbered edges on the SCK input cause the data at the serial data input pin to be latched. Odd numbered edges cause the value previously latched from the serial data input pin to shift into the LSB of the SPI shifter.

When CPHA is set, the first edge is used to get the first data bit onto the serial data output pin. When CPHA is clear and the \overline{SS} input is low (slave selected), the first bit of the SPI data is driven out of the serial data output pin. After the eighth shift, the transfer is considered complete and the received data is transferred into the SPI data register. To indicate transfer is complete, the SPIF flag in the SPI status register is set.

During an SPI transmission, data is transmitted (shifted out serially) and received (shifted in serially) simultaneously. The serial clock (SCK) synchronizes shifting and sampling of the information on the two serial data lines. A slave select line allows selection of an individual slave SPI device; slave devices that are not selected do not interfere with SPI bus activities. Optionally, on a master SPI device, the slave select line can be used to indicate multiple-master bus contention.

Transmission Formats

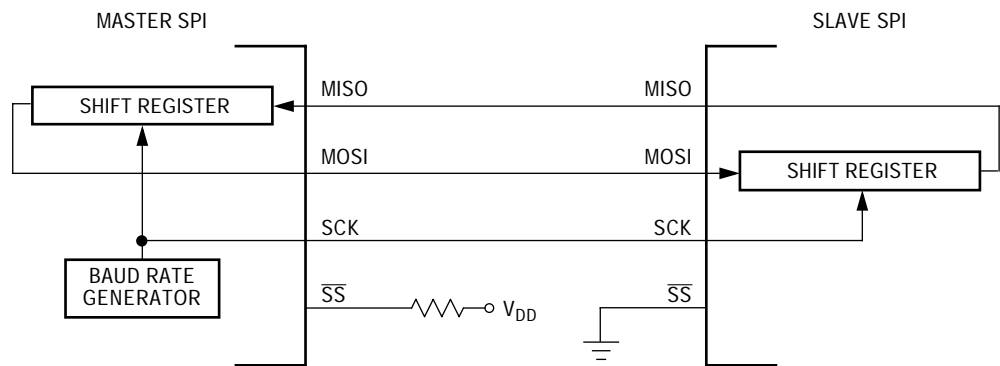

Figure 82 Master/Slave Transfer Block Diagram

Serial Peripheral Interface (SPI)*Clock Phase and Polarity Controls*

Using two bits in the SPI control register¹, software selects one of four combinations of serial clock phase and polarity.

The CPOL clock polarity control bit specifies an active high or low clock and has no significant effect on the transmission format.

The CPHA clock phase control bit selects one of two fundamentally different transmission formats.

Clock phase and polarity should be identical for the master SPI device and the communicating slave device. In some cases, the phase and polarity are changed between transmissions to allow a master device to communicate with peripheral slaves having different requirements.

CPHA = 0 Transfer Format

The first edge on the SCK line is used to clock the first data bit of slave into the master and the first data bit of master into the slave. In some peripherals, the first bit of the slave's data is available at the slave data out pin as soon as the slave is selected. In this format, the first SCK edge is not issued until a half cycle into the 8-cycle transfer operation. The first edge of SCK is delayed a half cycle by clearing the CPHA bit.

The SCK output from the master remains in the inactive state for a half SCK period before the first edge appears. A half SCK cycle later, the second edge appears on the SCK line. When this second edge occurs, the value previously latched from the serial data input pin is shifted into the LSB of the shifter.

After this second edge, the next bit of the SPI master data is transmitted out of the serial data output pin of the master to the serial input pin on the slave. This process continues for a total of 16 edges on the SCK line, with data being latched on odd numbered edges and shifted on even numbered edges.

Data reception is double buffered. Data is shifted serially into the SPI shift register during the transfer and is transferred to the parallel SPI data register after the last bit is shifted in.

After the 16th (last) SCK edge:

- Data that was previously in the master SPI data register should now be in the slave data register and the data that was in the slave data register should be in the master.
- The SPIF flag in the SPI status register is set indicating that the transfer is complete.

Figure 83 is a timing diagram of an SPI transfer where CPHA = 0. SCK waveforms are shown for CPOL = 0 and CPOL = 1. The diagram may be interpreted as a master or slave timing diagram since the SCK, MISO, and MOSI pins are connected directly between the master and the slave. The MISO signal is the output from the slave and the MOSI signal is the output from the master. The \overline{SS} pin of the master must be either high or reconfigured as a general-purpose output not affecting the SPI.

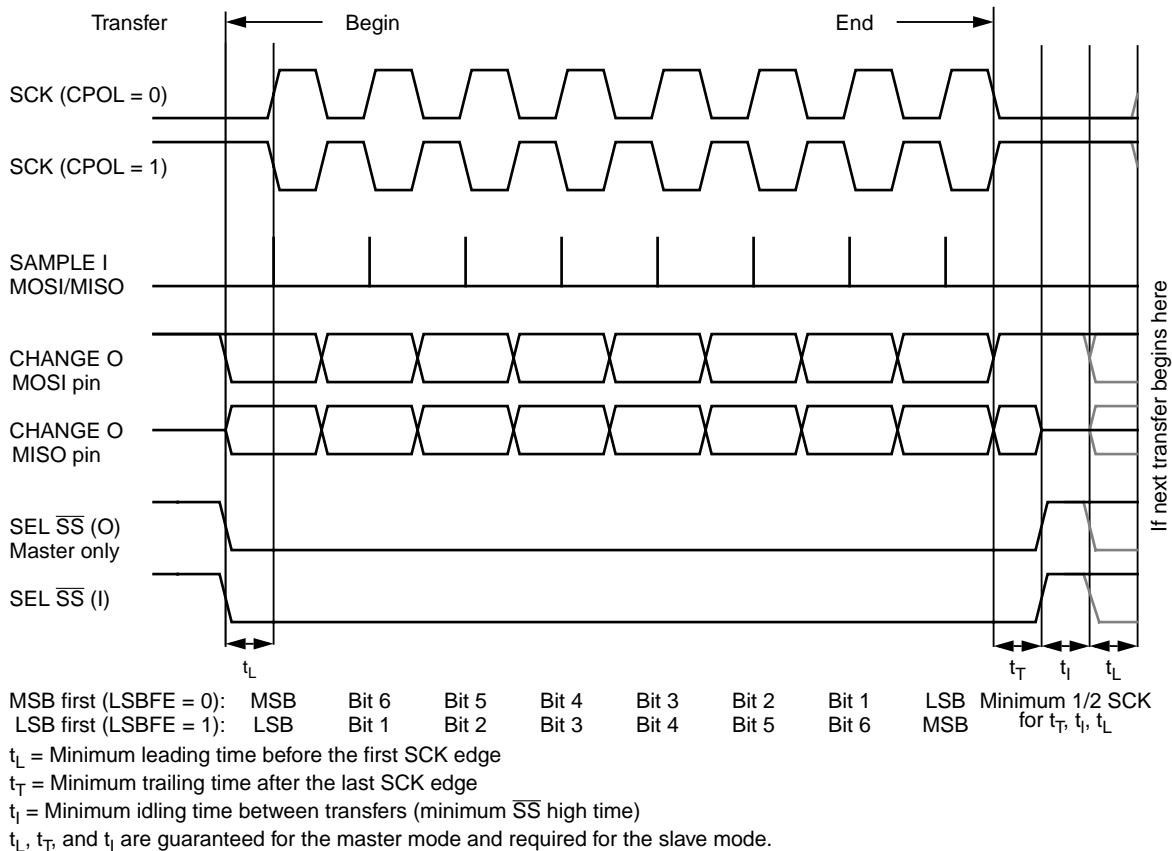

Figure 83 SPI Clock Format 0 (CPHA = 0)

Serial Peripheral Interface (SPI)

The \overline{SS} line can remain active low between successive transfers.

NOTE: *There is a functional hazard, the SPI may lose data in this mode (CPHA=0) if configured as a slave with the SCK rate at div2 of the slave's module clock (see [Errata](#)).*

CPHA = 1 Transfer Format

Some peripherals require the first SCK edge before the first data bit becomes available at the data out pin; the second edge clocks data into the system. In this format, the first SCK edge is issued by setting the CPHA bit at the beginning of the 8-cycle transfer operation.

The first edge of SCK occurs immediately after the half SCK clock cycle synchronization delay. This first edge commands the slave to transfer its most significant data bit to the serial data input pin of the master.

A half SCK cycle later, the second edge appears on the SCK pin. This is the latching edge for both the master and slave.

When the third edge occurs, the value previously latched from the serial data input pin is shifted into the LSB of the SPI shifter. After this edge, the next bit of the master data is coupled out of the serial data output pin of the master to the serial input pins on the slave.

This process continues for a total of 16 edges on the SCK line with data being latched on even numbered edges and shifting taking place on odd numbered edges.

Data reception is double buffered; data is serially shifted into the SPI shift register during the transfer and is transferred to the parallel SPI data register after the last bit is shifted in.

After the 16th SCK edge:

- Data that was previously in the SPI data register of the master is now in the data register of the slave, and data that was in the data register of the slave is in the master.
- The SPIF flag bit in SPISR is set indicating that the transfer is complete.

[Figure 84](#) shows two clocking variations for CPHA = 1. The diagram may be interpreted as a master or slave timing diagram since the SCK, MISO,

and MOSI pins are connected directly between the master and the slave. The MISO signal is the output from the slave, and the MOSI signal is the output from the master. The \overline{SS} line is the slave select input to the slave. The \overline{SS} pin of the master must be either high or reconfigured as a general-purpose output not affecting the SPI.

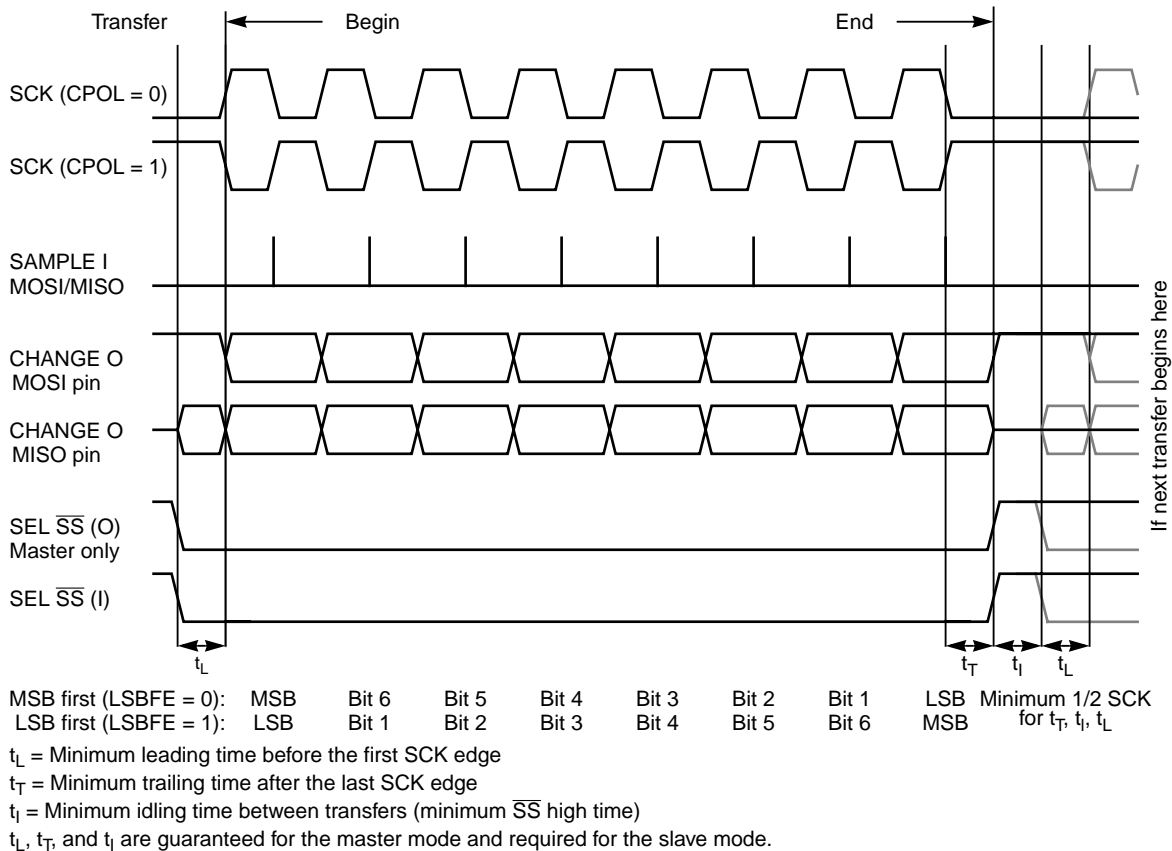

Figure 84 SPI Clock Format 1 (CPHA = 1)

The \overline{SS} line can remain active low between successive transfers (can be tied low at all times). This format is sometimes preferred in systems having a single fixed master and a single slave that drive the MISO data line.

The SPI interrupt request flag (SPIF) is common to both the master and slave modes. SPIF gets set after the last SCK cycle in a data transfer operation to indicate that the transfer is complete. SPIF is cleared

Serial Peripheral Interface (SPI)

automatically when the SPI status register is read (with SPIF set) followed by a read or write to the SPI data register. If the SPIE bit is set when the SPIF flag is set, a hardware interrupt is requested.

SPI Baud Rate Generation

Baud rate generation consists of a series of divider stages. Six bits in the SPI baud rate register (SPPR2, SPPR1, SPPR0, SPR2, SPR1, and SPR0) determine the divisor to the SPI module clock which results in the SPI baud rate.

The SPI clock rate is determined by the product of the value in the baud rate preselection bits (SPPR2–SPPR0) and the value in the baud rate selection bits (SPR2–SPR0). The module clock divisor equation is shown in [Figure 85](#).

When all bits are clear (the default condition), the SPI module clock is divided by 2. When the selection bits (SPR2–SPR0) are 001 and the preselection bits (SPPR2–SPPR0) are 000, the module clock divisor becomes 4. When the selection bits are 010, the module clock divisor becomes 8, etc.

When the preselection bits are 001, the divisor determined by the selection bits is multiplied by 2. When the preselection bits are 010, the divisor is multiplied by 3, etc. See [Table 78](#) for baud rate calculations for all bit conditions, based on a 25 MHz SPI module clock. The two sets of selects allows the clock to be divided by a non-power of two to achieve other baud rates such as divide by 6, divide by 10, etc.

The baud rate generator is activated only when the SPI is in the master mode and a serial transfer is taking place. In the other cases, the divider is disabled to decrease I_{DD} current.

$$\text{BaudRateDivisor} = (\text{SPPR} + 1) \cdot 2^{(\text{SPR} + 1)}$$

Figure 85 Baud Rate Divisor Equation

Special Features

\overline{SS} Output

The \overline{SS} output feature automatically drives the \overline{SS} pin low during transmission to select external devices and drives it high during idle to deselect external devices. When \overline{SS} output is selected, the \overline{SS} output pin is connected to the \overline{SS} input pin of the external device.

The \overline{SS} output is available only in master mode during normal SPI operation by asserting SSOE and MODFEN bit as shown in [Table 76](#).

The mode fault feature is disabled while \overline{SS} output is enabled.

NOTE: *Care must be taken when using the \overline{SS} output feature in a multimaster system since the mode fault feature is not available for detecting system errors between masters.*

Bidirectional Mode (MOMI or SISO)

The bidirectional mode is selected when the SPC0 bit is set in SPI control register 2 (see [Normal Mode and Bidirectional Mode](#)). In this mode, the SPI uses only one serial data pin for the interface with external device(s). The MSTR bit decides which pin to use. The MOSI pin becomes the serial data I/O (MOMI) pin for the master mode, and the MISO pin becomes serial data I/O (SISO) pin for the slave mode. The MISO pin in the master mode and MOSI pin in the slave mode become general-purpose I/O.

Serial Peripheral Interface (SPI)

Table 79 Normal Mode and Bidirectional Mode

When SPE = 1	Master Mode MSTR = 1	Slave Mode MSTR = 0
<p>Normal Mode SPC0 = 0</p>		
<p>Bidirectional Mode SPC0 = 1</p>		

The direction of each serial I/O pin depends on the BIDIROE bit. If the pin is configured as an output, serial data from the shift register is driven out on the pin. The same pin is also the serial input to the shift register.

The SCK is output for the master mode and input for the slave mode.

The \overline{SS} is the input or output for the master mode, and it is always the input for the slave mode.

The bidirectional mode does not affect SCK and \overline{SS} functions.

Error Conditions

The SPI has one error condition

- Mode fault error

Mode Fault Error

If the \overline{SS} input becomes low while the SPI is configured as a master, it indicates a system error where more than one master may be trying to drive the MOSI and SCK lines simultaneously. This condition is not permitted in normal operation; the MODF bit in the SPI status register is set automatically provided the MODFEN bit is set.

In the special case where the MODFEN bit is cleared, the \overline{SS} pin is a general purpose input/output pin for the SPI system configured in master mode. In this special case, the mode error function is inhibited and MODF remains cleared.

In case the SPI system is configured as a slave and the MODFEN bit is cleared the \overline{SS} pin is a dedicated input pin.

When a mode fault error occurs, the SPE and MSTR bits are cleared thereby clearing the output enable for the SCK, MISO, and MOSI (for MOMI) pins cleared. This forces those pins to be high impedance inputs to avoid any possibility of conflict with another output driver.

If the mode fault error occurs in the bidirectional mode for a SPI system configured in master mode, MISO (SISO) is not affected. No mode fault error occurs in the bidirectional mode for SPI system configured in slave mode.

The mode fault flag is cleared automatically by a read of the SPI status register (with MODF set) followed by a write to SPI control register 1.

Low Power Mode Options

SPI in Run Mode In run mode with the SPI system enable (SPE) bit in the SPI control register clear, the SPI system is in a low-power, disabled state. SPI registers can still be accessed, but clocks to the core of this module are disabled.

SPI in Wait Mode SPI operation in wait mode depends upon the state of the SPISWAI bit in SPI control register 2.

- If SPISWAI is clear, the SPI operates normally when the CPU is in wait mode
- If SPISWAI is set, SPI clock generation ceases and the SPI module enters a power conservation state when the CPU is in wait mode.

Serial Peripheral Interface (SPI)

- If SPISWAI is set and the SPI is configured for master, any transmission and reception in progress stops at wait mode entry. The transmission and reception resumes when the SPI exits wait mode.
- If SPISWAI is set and the SPI is configured as a slave, any transmission and reception in progress continues if the SCK continues to be driven from the master. This keeps the slave synchronized to the master and the SCK.

If the master transmits several bytes while the slave is in wait mode, the slave will continue to send out bytes consistent with the its operation mode at the start of wait mode (i.e. If the slave is currently sending its SPIDR to the master, it will continue to send the same byte. Else if the slave is currently sending the last received byte from the master, it will continue to send each previous master byte).

NOTE: *Care must be taken when expecting data from a master while the slave is in wait or stop mode. Even though the shift register will continue to operate, the rest of the SPI is shut down (i.e. a SPIF interrupt will **not** be generated until exiting stop or wait mode). Also, the byte from the shift register will not be copied into the SPIDR register until after the slave SPI has exited wait or stop mode. A SPIF flag and SPIDR copy is only generated if wait mode is entered or exited during a transmission. If the slave enters wait mode in idle mode and exits wait mode in idle mode, neither a SPIF nor a SPIDR copy will occur.*

SPI in Stop Mode

Stop mode is dependent on the system. The SPI enters stop mode when the module clock is disabled (held high or low). If the SPI is in master mode and exchanging data when the CPU enters stop mode, the transmission is frozen until the CPU exits stop mode. After stop, data to and from the external SPI is exchanged correctly. In slave mode, the SPI will stay synchronized with the master.

The stop mode is equivalent to the wait mode with the SPISWAI bit set except that the stop mode is not dependent on the SPISWAI bit.

Errata

There is a case where data may be lost between the master and slave SPI modules. This occurs only if the following settings are true:

1. SCK is running at busclock/2 in slave mode of operation
2. Transmission protocol CPHA = 0
3. SPIDR write to slave just before SS sync goes low

Figure 86 depicts the module clock just before the SCK edge. Since the SPTEF flag is high a write to the SPIDR is allowed in cycle shown in the figure.

This write results in a load of the shifter, which in turn causes the MISO to change. The changing MISO happens at about the time when the master wishes to sample the MISO line. The first bit of the transfer may not be stable when the master samples it, so the byte sent to the master may be corrupted.

Figure 86 Data Transfer Error

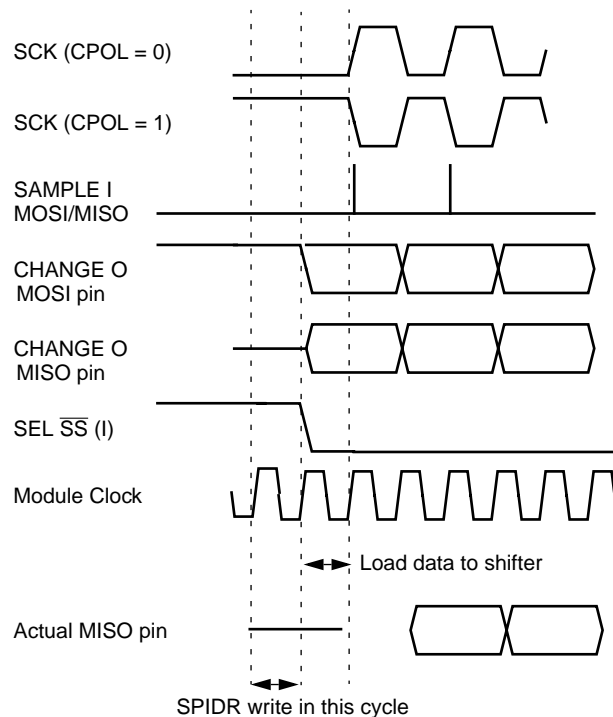

Serial Peripheral Interface (SPI)

This hazard is most visible when the SCK runs at div2 of the slave's module clock. At other baud rates, there is more time between the falling SS signal and the first SCK edge. i.e. div4 has two module clocks between the SS fall and the SCK edge.

Reset

The reset values of registers and signals are described in [Registers](#). All registers reset to a particular value. If a data transmission occurs in slave mode after reset without a write to SPIDR, it will transmit random data or the byte last received from the master before the reset. Reading from the SPIDR after reset will always read a byte of zeros.

Interrupts

This section describes interrupts originated by the Serial Peripheral Interface. The MCU must service the interrupt requests. [Table 80](#) lists the three sources of interrupts generated by the SPI module. The SPI module communicates with the MCU through one interrupt port.

Table 80 SPI Interrupt Signals

Interrupt sources ⁽¹⁾	Offset	Vector	Priority	Interrupt Port	Description
Mode Fault	Chip Dependent	Chip Dependent	Chip Dependent	spi_int	Active high detect. MODF occurs when a logic zero occurs on the \overline{SS} pin of a master SPI
Transfer Complete	Chip Dependent	Chip Dependent	Chip Dependent	spi_int	Active high detect. SPIF occurs after the last SCK cycle in a data transfer operation to indicate that the transfer is complete.
SPI Transmitter Empty	Chip Dependent	Chip Dependent	Chip Dependent	spi_int	Active high detect. SPTEF occurs when the SPI data register transfers a byte into the Transmit shift register.

1. SPI Interrupts must be enabled by setting the SPIE bit or SPTIE bit in the SPICR1. Otherwise, *_int signal will never toggle to high.

Description of Interrupt Operation	<p>The Serial Peripheral Interface only originates interrupt requests. The following is a description of how the Serial Peripheral Interface makes a request and how the MCU should acknowledge that request. The interrupt vector offset and interrupt priority are chip dependent.</p>
<i>MODF Description</i>	<p>MODF occurs when the master detects an error on the \overline{SS} pin. The master SPI must be configured for the MODF feature (see Table 76). Once MODF is set, the current transfer is halted and the following bits are changed:</p> <ul style="list-style-type: none"> • SPE=0, The SPI automatically disables itself. • MSTR=0, The master bit in SPICR1 resets. <p>The MODF interrupt is reflected in the status register MODF flag. Clearing the flag will also clear the interrupt. This interrupt will stay active while the MODF flag is set. MODF has an automatic clearing process which is described in SPI Status Register (SPISR).</p>
<i>SPIF Description</i>	<p>SPIF occurs when the SPI receives/transmits the last SCK edge in a data transfer operation. Once SPIF is set, it does not clear until it is serviced. SPIF has an automatic clearing process which is described in SPI Status Register (SPISR). In the event that the SPIF is not serviced before the end of the next transfer (i.e. SPIF remains active throughout another transfer), the latter transfers will be ignored and no new data will be copied into the SPIDR.</p>
<i>SPTEF Description</i>	<p>SPTEF occurs when the SPI Data register transfers a byte into the transmit buffer. Once SPTEF is set, it does not clear until it is serviced. SPTEF has an automatic clearing process which is described in SPI Status Register (SPISR).</p>



Inter-IC Bus (IIC)

Contents

Overview	463
Features	464
Modes of Operation	464
Block Diagram	465
Signal Descriptions	467
Module Memory Map	468
Register Quick Reference	469
Register Descriptions	469
I-Bus Protocol	478
Interrupt Operation	483
Modes of Operation	484
Programming	485

Overview

The Inter-IC Bus (IIC or I2C) is a two-wire, bidirectional serial bus that provides a simple, efficient method of data exchange between devices. Being a two-wire device, the IIC Bus minimizes the need for large numbers of connections between devices, and eliminates the need for an address decoder.

This bus is suitable for applications requiring occasional communications over a short distance between a number of devices. It also provides flexibility, allowing additional devices to be connected to the bus for further expansion and system development.

The interface is designed to operate up to 100Kbps with maximum bus loading and timing. The device is capable of operating at higher baud rates, up to a maximum of clock/20, with reduced bus loading. The

maximum communication length and the number of devices that can be connected are limited by a maximum bus capacitance of 400pF.

Features

The IIC module has the following key features:

- Compatible with I2C Bus standard
- Multi-master operation
- Software programmable for one of 256 different serial clock frequencies
- Software selectable acknowledge bit
- Interrupt driven byte-by-byte data transfer
- Arbitration lost interrupt with automatic mode switching from master to slave
- Calling address identification interrupt
- Start and stop signal generation/detection
- Repeated start signal generation
- Acknowledge bit generation/detection
- Bus busy detection

Modes of Operation

The IIC functions the same in normal, special, and emulation modes. It has two low power modes, wait and stop modes.

- Run Mode

This is the basic mode of operation.

- Wait Mode

IIC operation in wait mode is a configurable low power mode. Depending on the state of internal bits, the IIC can operate normally when the CPU is in wait mode or the IIC clock generation can be turned off and the IIC module enters a power conservation state during wait mode. In the later case, any transmission or reception in progress stops at wait mode entry.

- Stop Mode

The IIC is inactive in stop mode for reduced power consumption. The STOP instruction does not affect IIC register states.

Block Diagram

The block diagram of the IIC module is shown in [Figure 87](#).

Inter-IC Bus (IIC)

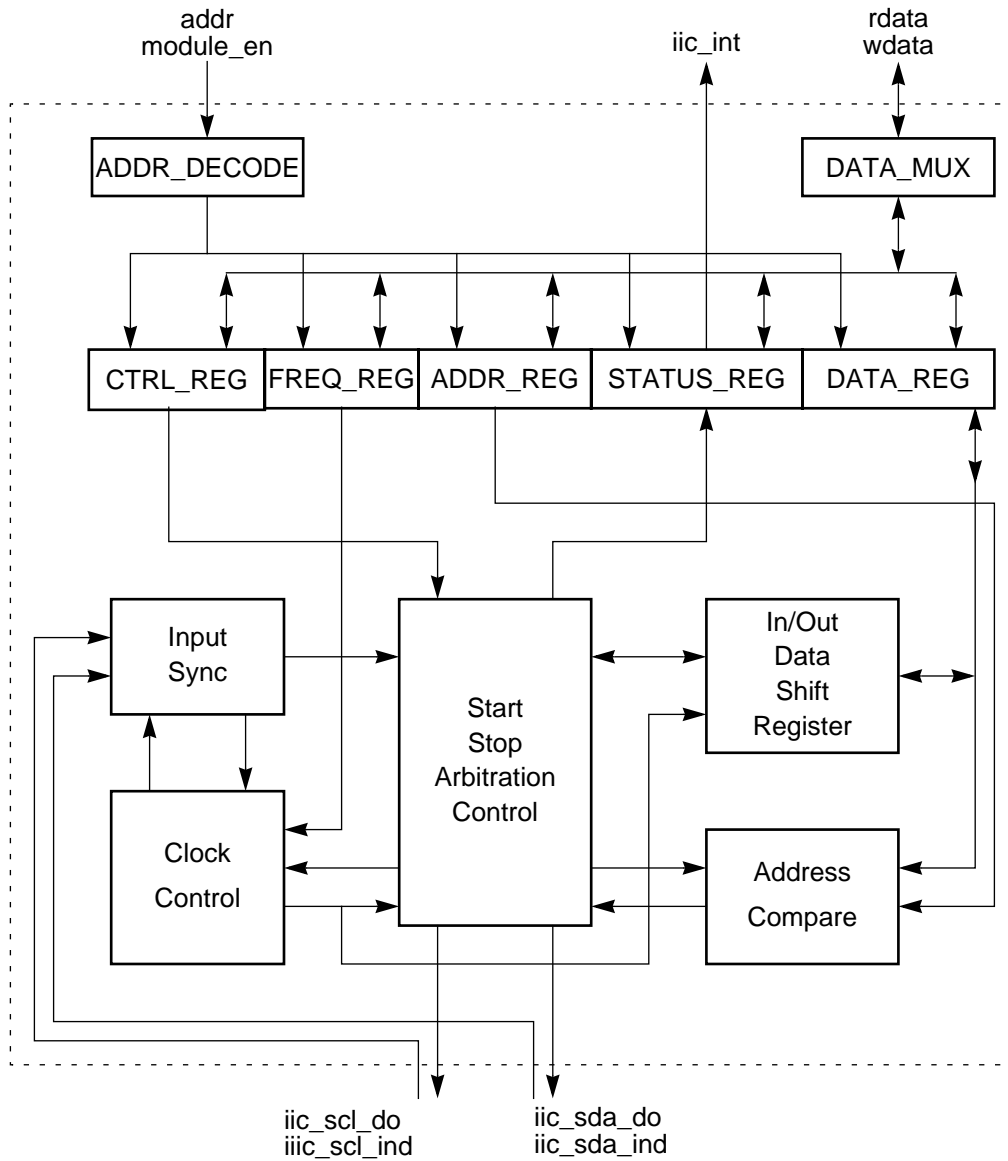

Figure 87 IIC Block Diagram

Signal Descriptions

The IIC is a 16-bit module.

Table 81 Signal Properties

Name	Function
iic_scl_ind	SCL input signal from pad
iic_scl_do	SCL data output from module
iic_scl_port_en	SCL enable signal
iic_scl_obe	SCL input/output configure
iic_sda_ind	SDA input signal from pad
iic_sda_do	SDA data output from module
iic_sda_port_en	SDA enable signal
iic_sda_obe	SDA input/output configure
iic_int	IIC interrupt signal

- iic_scl_ind** This is the unsynchronized SCL input from the pad.
- iic_scl_do** This is the SCL data output from the module.
- iic_scl_port_en** SCL pad enable signal. This signal is an output of the IIC and is made active when the IIC wants to control the SCL pad.
- iic_scl_obe** If the pad is controlled by the IIC, then this signal determines whether the IIC will drive **iic_scl_do**.
- iic_sda_ind** This is the unsynchronized SDA input from the pad.
- iic_sda_do** This is the SDA output from the module.
- iic_sda_port_en** SDA pad enable signal. This signal is an output of the IIC and is made active when the IIC wants to control the SDA pad.

Inter-IC Bus (IIC)

iic_sda_obe If the pad is controlled by the IIC, then this signal determines whether the IIC will drive **iic_sda_do**.

Interrupt Signals The IIC has one interrupt signal **iic_int**. Refer to Section 6 of this document for the details regarding this signal.

Module Memory Map

The memory map for the IIC module is given below in **Table 3-1**. The Address listed for each register is the address offset. The total address for each register is the sum of the base address for the IIC module and the address offset for each register.

Table 82 Module Memory Map

Offset	Use	Access
\$0000	IIC Address Register	Read/Write
\$0001	IIC Frequency Divider Register	Read/Write
\$0002	IIC Control Register	Read/Write
\$0003	IIC Status Register)	Read/Write
\$0004	IIC Data I/O Register	Read/Write

Register Quick Reference

Table 83 Register Quick Reference

Register name		Bit 7	6	5	4	3	2	1	Bit 0	Addr. offset
IBAD	Read:	ADR7	ADR6	ADR5	ADR4	ADR3	ADR2	ADR1	0	\$0000
	Write:									
	Reset	0	0	0	0	0	0	0	0	
IBFD	Read:	IBC7	IBC6	IBC5	IBC4	IBC3	IBC2	IBC1	IBC0	\$0001
	Write:									
	Reset	0	0	0	0	0	0	0	0	
IBCR	Read:	IBEN	IBIE	MS/SL	Tx/Rx	TXAK	RSTA	0	IBSWAI	\$0002
	Write:									
	Reset	0	0	0	0	0	0	0	0	
IBSR	Read:	TCF	IAAS	IBB	IBAL	0	SRW	IBIF	RXAK	\$0003
	Write:									
	Reset	1	0	0	0	0	0	0	0	
IBDR	Read:	D7	D6	D5	D4	D3	D2	D1	D0	\$0004
	Write:									
	Reset	0	0	0	0	0	0	0	0	

Register Descriptions

This section consists of register descriptions in address order. Each description includes a standard register diagram with an associated figure number. Details of register bit and field function follow the register diagrams, in bit order.

Inter-IC Bus (IIC)

IIC Address Register (IBAD)

Address Offset: \$0000

	Bit 7	6	5	4	3	2	1	Bit 0
	ADR7	ADR6	ADR5	ADR4	ADR3	ADR2	ADR1	0
RESET:	0	0	0	0	0	0	0	0

Read and write anytime

This register contains the address the IIC Bus will respond to when addressed as a slave; note that it is not the address sent on the bus during the address transfer

ADR7–ADR1 — Slave Address

Bit 1 to bit 7 contain the specific slave address to be used by the IIC Bus module.

The default mode of IIC Bus is slave mode for an address match on the bus.

RESERVED

Bit 0 of the IBAD is reserved for future compatibility. This bit will always read 0.

**IIC Frequency
Divider Register
(IBFD)**

Address Offset: \$0001

	Bit 7	6	5	4	3	2	1	Bit 0
	IBC7	IBC6	IBC5	IBC4	IBC3	IBC2	IBC1	IBC0
Reset:	0	0	0	0	0	0	0	0

Read and write anytime

IBC7–IBC0 — I-Bus Clock Rate 7–0

This field is used to prescale the clock for bit rate selection. The bit clock generator is implemented as a prescale divider: IBC7–6 and IBC5–3 select the prescaler divider, and IBC2–0 select the shift register tap point. The IBC bits are decoded to give the Tap and Prescale values as shown in [Table 84](#).

Table 84 I-Bus Tap and Prescale Values

IBC2-0 (bin)	SCL Tap (clocks)	SDA Tap (clocks)
000	5	1
001	6	1
010	7	2
011	8	2
100	9	3
101	10	3
110	12	4
111	15	4

IBC5-3 (bin)	scl2tap (clocks)	tap2tap (clocks)
000	5	1
001	6	2
010	6	4
011	6	8
100	14	16
101	30	32
110	62	64

IBC5-3 (bin)	scl2tap (clocks)	tap2tap (clocks)
111	126	128

Table 85 Divider Factor

IBC7-6	DIV
00	1
01	2
10	4
11	RESERVED

The number of clocks from the falling edge of SCL to the first tap (Tap[1]) is defined by the values shown in the scl2tap column of [Figure 84](#), all subsequent tap points are separated by $2^{\text{IBC5-3}}$ as shown in the tap2tap column in [Figure 84](#). The SCL Tap is used to generate the SCL period and the SDA Tap is used to determine the delay from the falling edge of SCL to SDA changing, the SDA hold time.

IBC7–6 defines the divider factor DIV. The values of DIV are shown in [Table 85](#).

The equation used to generate the divider values from the IBFD bits is:

$$\text{SCL Divider} = \text{DIV} \times \{ 2 \times (\text{scl2tap} + [(\text{SCL_Tap} - 1) \times \text{tap2tap}] + 2) \}$$

The SDA hold delay is equal to the CPU clock period multiplied by the SDA Hold value shown in **Table 1-2**. The equation used to generate the SDA Hold value from the IBFD bits is:

$$\text{SCL Hold} = \text{DIV} \times \{ \text{scl2tap} + [(\text{SCL_Tap} - 1) \times \text{tap2tap}] + 3 \}$$

**IIC Control
Register (IBCR)**

Address Offset: \$0002

	Bit 7	6	5	4	3	2	1	Bit 0
	IBEN	IBIE	MS/ \overline{SL}	Tx/ \overline{Rx}	TXAK	RSTA	0	IBSWAI
Reset:	0	0	0	0	0	0	0	0

Read and write anytime

IBEN — I-Bus Enable

This bit controls the software reset of the entire IIC Bus module.

- 1 = The IIC Bus module is enabled. This bit must be set before any other IBCR bits have any effect.
- 0 = The module is reset and disabled. This is the power-on reset situation. When low the interface is held in reset but registers can still be accessed.

If the IIC Bus module is enabled in the middle of a byte transfer the interface behaves as follows: slave mode ignores the current transfer on the bus and starts operating whenever a subsequent start condition is detected. Master mode will not be aware that the bus is busy, hence if a start cycle is initiated then the current bus cycle may become corrupt. This would ultimately result in either the current bus master or the IIC Bus module losing arbitration, after which bus operation would return to normal.

IBIE — I-Bus Interrupt Enable

- 1 = Interrupts from the IIC Bus module are enabled. An IIC Bus interrupt occurs provided the IBIF bit in the status register is also set.
- 0 = Interrupts from the IIC Bus module are disabled. Note that this does not clear any currently pending interrupt condition.

MS/ \overline{SL} — Master/Slave mode select bit

Upon reset, this bit is cleared. When this bit is changed from 0 to 1, a START signal is generated on the bus, and the master mode is selected. When this bit is changed from 1 to 0, a STOP signal is

generated and the operation mode changes from master to slave. $\overline{MS/SL}$ is cleared without generating a STOP signal when the master loses arbitration.

1 = Master Mode

0 = Slave Mode

Tx/\overline{Rx} — Transmit/Receive mode select bit

This bit selects the direction of master and slave transfers. When addressed as a slave this bit should be set by software according to the SRW bit in the status register. In master mode this bit should be set according to the type of transfer required. Therefore, for address cycles, this bit will always be high.

1 = Transmit

0 = Receive

TXAK — Transmit Acknowledge enable

This bit specifies the value driven onto SDA during data acknowledge cycles for both master and slave receivers. The IIC module will always acknowledge address matches, provided it is enabled, regardless of the value of TXAK. Note that values written to this bit are only used when the IIC Bus is a receiver, not a transmitter.

1 = No acknowledge signal response is sent (i.e., acknowledge bit = 1)

0 = An acknowledge signal will be sent out to the bus at the 9th clock bit after receiving one byte data

RSTA — Repeat Start

Writing a 1 to this bit will generate a repeated START condition on the bus, provided it is the current bus master. This bit will always be read as a low. Attempting a repeated start at the wrong time, if the bus is owned by another master, will result in loss of arbitration.

1 = Generate repeat start cycle

RESERVED

Bit 1 of the IBCR is reserved for future compatibility. This bit will always read 0.

IBSWAI — I-Bus Interface Stop in WAIT mode

1 = Halt IIC Bus module clock generation in WAIT mode

0 = IIC Bus module clock operates normally

Wait mode is entered via execution of a CPU WAI instruction. In the event that the IBSWAI bit is set, all clocks internal to the IIC will be stopped and any transmission currently in progress will halt. If the CPU were woken up by a source other than the IIC module, then clocks would restart and the IIC would continue where it left off in the previous transmission. It is not possible for the IIC to wake up the CPU when its internal clocks are stopped.

If it were the case that the IBSWAI bit was cleared when the WAI instruction was executed, the IIC internal clocks and interface would remain alive, continuing the operation which was currently underway. It is also possible to configure the IIC such that it will wake up the CPU via an interrupt at the conclusion of the current operation. See the discussion on the IBIF and IBIE bits in the IBSR and IBCR, respectively.

IIC Status Register (IBSR)

Address Offset: \$0003

	Bit 7	6	5	4	3	2	1	Bit 0
	TCF	IAAS	IBB	IBAL	0	SRW	IBIF	RXAK
Reset:	1	0	0	0	0	0	0	0

This status register is read-only with exception of bit 1 (IBIF) and bit 4 (IBAL), which are software clearable

TCF — Data transferring bit

While one byte of data is being transferred, this bit is cleared. It is set by the falling edge of the 9th clock of a byte transfer. Note that this bit is only valid during or immediately following a transfer to the IIC module or from the IIC module.

- 1 = Transfer complete
- 0 = Transfer in progress

IAAS — Addressed as a slave bit

When its own specific address (I-Bus Address Register) is matched with the calling address, this bit is set. The CPU is interrupted provided the IBIE is set. Then the CPU needs to check the SRW bit and set its Tx/Rx mode accordingly. Writing to the I-Bus Control Register clears this bit.

- 1 = Addressed as a slave
- 0 = Not addressed

IBB — Bus busy bit

This bit indicates the status of the bus. When a START signal is detected, the IBB is set. If a STOP signal is detected, it is cleared.

- 1 = Bus is busy
- 0 = Bus is idle

IBAL — Arbitration Lost

The arbitration lost bit (IBAL) is set by hardware when the arbitration procedure is lost. Arbitration is lost in the following circumstances:

1. SDA sampled as a low when the master drives a high during an address or data transmit cycle.
2. SDA sampled as a low when the master drives a high during the acknowledge bit of a data receive cycle.
3. A start cycle is attempted when the bus is busy.
4. A repeated start cycle is requested in slave mode.
5. A stop condition is detected when the master did not request it.

This bit must be cleared by software, by writing a low to it.

RESERVED

Bit 3 of IBSR is reserved for future use. A read operation on this bit will return 0.

SRW — Slave Read/Write

When IAAS is set this bit indicates the value of the R/W command bit of the calling address sent from the master.

This bit is only valid when the I-Bus is in slave mode, a complete address transfer has occurred with an address match and no other transfers have been initiated.

Checking this bit, the CPU can select slave transmit/receive mode according to the command of the master.

- 1 = Slave transmit, master reading from slave
- 0 = Slave receive, master writing to slave

IBIF — I-Bus Interrupt

The IBIF bit is set when an interrupt is pending, which will cause a processor interrupt request provided IBIE is set. IBIF is set when one of the following events occurs:

1. Complete one byte transfer (set at the falling edge of the 9th clock).
2. Receive a calling address that matches its own specific address in slave receive mode.
3. Arbitration lost.

This bit must be cleared by software, writing a low to it, in the interrupt routine.

RXAK — Received Acknowledge

The value of SDA during the acknowledge bit of a bus cycle. If the received acknowledge bit (RXAK) is low, it indicates an acknowledge signal has been received after the completion of 8 bits data transmission on the bus. If RXAK is high, it means no acknowledge signal is detected at the 9th clock.

- 1 = No acknowledge received
- 0 = Acknowledge received

Inter-IC Bus (IIC)

IIC Data I/O Register (IBDR)

Address Offset: \$0004

	Bit 7	6	5	4	3	2	1	Bit 0
	D7	D6	D5	D4	D3	D2	D1	D0
Reset:	0	0	0	0	0	0	0	0

In master transmit mode, when data is written to the IBDR a data transfer is initiated. The most significant bit is sent first. In master receive mode, reading this register initiates next byte data receiving. In slave mode, the same functions are available after an address match has occurred. Note that the Tx/Rx bit in the IBCR must correctly reflect the desired direction of transfer in master and slave modes for the transmission to begin. For instance, if the IIC is configured for master transmit but a master receive is desired, then reading the IBDR will not initiate the receive.

Reading the IBDR will return the last byte received while the IIC is configured in either master receive or slave receive modes. The IBDR does not reflect every byte that is transmitted on the IIC bus, nor can software verify that a byte has been written to the IBDR correctly by reading it back.

In master transmit mode, the first byte of data written to IBDR following assertion of $\overline{MS/\overline{SL}}$ is used for the address transfer and should comprise of the calling address (in position D7-D1) concatenated with the required R/\overline{W} bit (in position D0).

I-Bus Protocol

The IIC Bus system uses a Serial Data line (SDA) and a Serial Clock Line (SCL) for data transfer. All devices connected to it must have open drain or open collector outputs. Logic AND function is exercised on both lines with external pull-up resistors, the value of these resistors is system dependent.

Normally, a standard communication is composed of four parts: START signal, slave address transmission, data transfer and STOP signal. They are described briefly in the following sections and illustrated in [Figure 88](#).

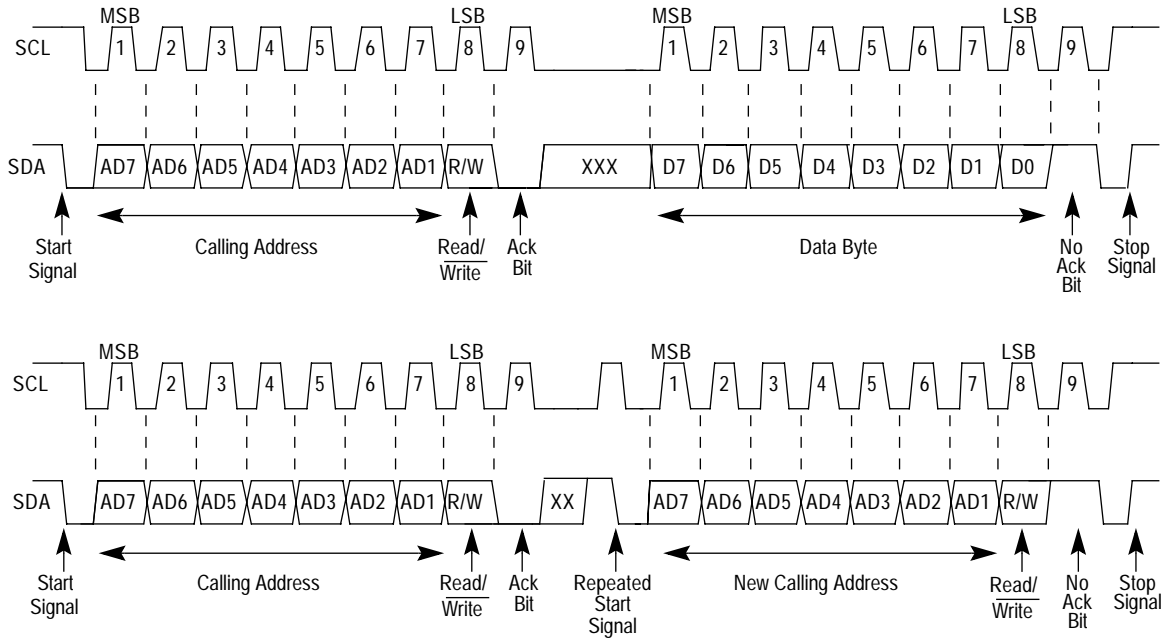

Figure 88 I-Bus Transmission Signals

START Signal

When the bus is free, i.e. no master device is engaging the bus (both SCL and SDA lines are at logical high), a master may initiate communication by sending a START signal. As shown in [Figure 88](#), a START signal is defined as a high-to-low transition of SDA while SCL is high. This signal denotes the beginning of a new data transfer (each data transfer may contain several bytes of data) and brings all slaves out of their idle states.

Slave Address Transmission

The first byte of data transfer immediately after the START signal is the slave address transmitted by the master. This is a seven-bit calling address followed by a R/W bit. The R/W bit tells the slave the desired direction of data transfer.

1 = Read transfer, the slave transmits data to the master.

0 = Write transfer, the master transmits data to the slave.

Only the slave with a calling address that matches the one transmitted by the master will respond by sending back an acknowledge bit. This is done by pulling the SDA low at the 9th clock (see [Figure 88](#)).

No two slaves in the system may have the same address. If the IIC Bus is master, it must not transmit an address that is equal to its own slave address. The IIC Bus cannot be master and slave at the same time. However, if arbitration is lost during an address cycle the IIC Bus will revert to slave mode and operate correctly even if it is being addressed by another master.

Data Transfer

Once successful slave addressing is achieved, the data transfer can proceed byte-by-byte in a direction specified by the R/W bit sent by the calling master.

All transfers that come after an address cycle are referred to as data transfers, even if they carry sub-address information for the slave device.

Each data byte is 8 bits long. Data may be changed only while SCL is low and must be held stable while SCL is high as shown in [Figure 88](#). There is one clock pulse on SCL for each data bit, the MSB being transferred first. Each data byte has to be followed by an acknowledge bit, which is signalled from the receiving device by pulling the SDA low at the ninth clock. So one complete data byte transfer needs nine clock pulses.

If the slave receiver does not acknowledge the master, the SDA line must be left high by the slave. The master can then generate a stop signal to abort the data transfer or a start signal (repeated start) to commence a new calling.

If the master receiver does not acknowledge the slave transmitter after a byte transmission, it means 'end of data' to the slave, so the slave releases the SDA line for the master to generate STOP or START signal.

STOP Signal	<p>The master can terminate the communication by generating a STOP signal to free the bus. However, the master may generate a START signal followed by a calling command without generating a STOP signal first. This is called repeated START. A STOP signal is defined as a low-to-high transition of SDA while SCL at logical “1” (see Figure 88).</p> <p>The master can generate a STOP even if the slave has generated an acknowledge at which point the slave must release the bus.</p>
Repeated START Signal	<p>As shown in Figure 88, a repeated START signal is a START signal generated without first generating a STOP signal to terminate the communication. This is used by the master to communicate with another slave or with the same slave in different mode (transmit/receive mode) without releasing the bus.</p>
Arbitration Procedure	<p>The Inter-IC bus is a true multi-master bus that allows more than one master to be connected on it. If two or more masters try to control the bus at the same time, a clock synchronization procedure determines the bus clock, for which the low period is equal to the longest clock low period and the high is equal to the shortest one among the masters. The relative priority of the contending masters is determined by a data arbitration procedure, a bus master loses arbitration if it transmits logic “1” while another master transmits logic “0”. The losing masters immediately switch over to slave receive mode and stop driving SDA output. In this case the transition from master to slave mode does not generate a STOP condition. Meanwhile, a status bit is set by hardware to indicate loss of arbitration.</p>
Clock Synchronization	<p>Since wire-AND logic is performed on SCL line, a high-to-low transition on SCL line affects all the devices connected on the bus. The devices start counting their low period and once a device's clock has gone low, it holds the SCL line low until the clock high state is reached. However, the change of low to high in this device clock may not change the state of the SCL line if another device clock is still within its low period. Therefore, synchronized clock SCL is held low by the device with the longest low period. Devices with shorter low periods enter a high wait</p>

state during this time (see Figure 89). When all devices concerned have counted off their low period, the synchronized clock SCL line is released and pulled high. There is then no difference between the device clocks and the state of the SCL line and all the devices start counting their high periods. The first device to complete its high period pulls the SCL line low again.

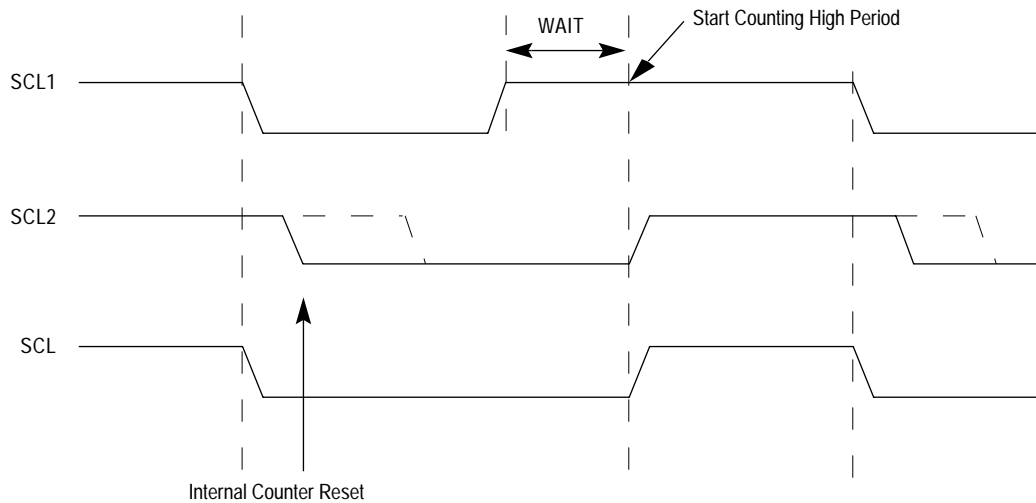

Figure 89 I-Bus Clock Synchronization

Handshaking

The clock synchronization mechanism can be used as a handshake in data transfer. Slave devices may hold the SCL low after completion of one byte transfer (9 bits). In such case, it halts the bus clock and forces the master clock into wait states until the slave releases the SCL line.

Clock Stretching

The clock synchronization mechanism can be used by slaves to slow down the bit rate of a transfer. After the master has driven SCL low the slave can drive SCL low for the required period and then release it. If the slave SCL low period is greater than the master SCL low period then the resulting SCL bus signal low period is stretched.

Interrupt Operation

**System Level
Interrupt Sources** There is one interrupt signal that is sent from the IIC to the core.

**Interrupt
Descriptions** See the Interrupts section of the End User Guide, which describes the Interrupt signals generated by the IIC Status registers.

Internally there are three types of interrupts. These are generated on

1. Arbitration Lost Interrupt
2. Byte Transfer Interrupt
3. Address Detect Interrupt

There is only one interrupt signal **iic_int** to **core**. The interrupt is driven by Bit IBIF (of the IIC Status Register) and masked with bit IBIE (of the IIC Control Register). This bit must be cleared by software by writing a low to it in the interrupt routine. **core** can determine the Interrupt type after reading the Status Register.

**Arbitration Lost
Interrupt** The Inter-IC bus is a true multi-master bus that allows more than one master to be connected on it. If two or more masters try to control the bus at the same time, the relative priority of the contending masters is determined by a data arbitration procedure. The IIC module asserts this interrupt when It loses the data arbitration process. And IBAL bit in Status Register is also set.

Arbitration is lost in the following circumstances:

1. SDA sampled as a low when the master drives a high during an address or data transmit cycle.
2. SDA sampled as a low when the master drives a high during the acknowledge bit of a data receive cycle.
3. A start cycle is attempted when the bus is busy.
4. A repeated start cycle is requested in slave mode.
5. A stop condition is detected when the master did not request it.

Inter-IC Bus (IIC)

This bit must be cleared by software, by writing a low to it.

Byte Transfer Interrupt After completion of byte transfer, TCF (Data Transfer) bit is set at the falling edge of the 9th clock to indicate the completion of Byte Transfer.

Address Detect Interrupt When its own specific address (I-Bus Address Register) is matched with the calling address, IAAS bit in Status register is set. The CPU is interrupted provided the IBIE is set. Then the CPU needs to check the SRW bit and set its Tx/Rx mode accordingly.

Modes of Operation

The IIC functions the same in normal, special, and emulation modes. It has two low power modes, wait and stop modes.

Run Mode This is the basic mode of operation.

Wait Mode IIC operation in wait mode is a configurable low power mode. Depending on the state of internal bits, the IIC can operate normally when the CPU is in wait mode or the IIC clock generation can be turned off and the IIC module enters a power conservation state during wait mode. In the later case, any transmission or reception in progress stops at wait mode entry.

Stop Mode The IIC is inactive in stop mode for reduced power consumption. The STOP instruction does not affect IIC register states.

Programming

Initialization Sequence

Reset will put the IIC Control Register to its default status. Before the interface can be used to transfer serial data, an initialization procedure must be carried out, as follows:

1. Update the Frequency Divider Register (IBFD) and select the required division ratio to obtain SCL frequency from system clock.
2. Update the IIC Address Register (IBAD) to define its slave address.
3. Set the IBEN bit of the IIC Control Register (IBCR) to enable the IIC system.
4. Modify the bits of the IIC Control Register (IBCR) to select Master/Slave mode, Transmit/Receive mode and interrupt enable or not.

Generation of START

After completion of the initialization procedure, serial data can be transmitted by selecting the 'master transmitter' mode. If the device is connected to a multi-master bus system, the state of the IIC Busy Bit (IBB) must be tested to check whether the serial bus is free.

If the bus is free (IBB=0), the start condition and the first byte (the slave address) can be sent. The data written to the data register comprises the slave calling address and the LSB set to indicate the direction of transfer required from the slave.

The bus free time (i.e., the time between a STOP condition and the following START condition) is built into the hardware that generates the START cycle. Depending on the relative frequencies of the system clock and the SCL period it may be necessary to wait until the IIC is busy after writing the calling address to the IBDR before proceeding with the following instructions. This is illustrated in the following example.

Inter-IC Bus (IIC)

An example of a program which generates the START signal and transmits the first byte of data (slave address) is shown below:

```

CHFLAG   BRSET   IBSR,#$20,*   ;WAIT FOR IBB FLAG TO CLEAR
TXSTART  BSET    IBCR,#$30    ;SET TRANSMIT AND MASTER MODE
                                     ;i.e. GENERATE START CONDITION
                                     ;TRANSMIT THE CALLING
                                     ;ADDRESS, D0=R/W
                                     ;WAIT FOR IBB FLAG TO SET
          MOVEB   CALLING,IBDR
IBFREE   BRCLR   #5,IBSR,#$20,*

```

**Post-Transfer
Software
Response**

Transmission or reception of a byte by the IIC will set the data transferring bit (TCF) to 1, which indicates one byte communication is finished. The IIC interrupt bit (IBIF) is set also; an interrupt will be generated if the interrupt function is enabled during initialization by setting the IBIE bit. Software must clear the IBIF bit in the interrupt routine first. The TCF bit will be cleared by reading from the IIC Data I/O Register (IBDR) in receive mode or writing to IBDR in transmit mode.

Software may service the IIC I/O in the main program by monitoring the IBIF bit if the interrupt function is disabled. Note that polling should monitor the IBIF bit rather than the TCF bit since their operation is different when arbitration is lost.

Note that when an interrupt occurs at the end of the address cycle the master will always be in transmit mode, i.e. the address is transmitted. If master receive mode is required, indicated by R/\overline{W} bit in IBDR, then the Tx/\overline{Rx} bit should be toggled at this stage.

During slave mode address cycles (IAAS=1) the SRW bit in the status register is read to determine the direction of the subsequent transfer and the Tx/\overline{Rx} bit is programmed accordingly. For slave mode data cycles (IAAS=0) the SRW bit is not valid, the Tx/\overline{Rx} bit in the control register should be read to determine the direction of the current transfer.

The following is an example of a software response by a 'master transmitter' in the interrupt routine (see [Figure 90](#)).

```

ISR      BCLR      IBSR,#$02          ;CLEAR THE IBIF FLAG
          BRCLR    IBCR,#$20,SLAVE    ;BRANCH IF IN SLAVE MODE
          BRCLR    IBCR,#$10,RECEIVE  ;BRANCH IF IN RECEIVE MODE
          BRSET    IBSR,#$01,END      ;IF NO ACK, END OF TRANSMISSION
TRANSMIT MOVB     DATABUF,IBDR       ;TRANSMIT NEXT BYTE OF DATA
  
```

Generation of STOP

A data transfer ends with a STOP signal generated by the 'master' device. A master transmitter can simply generate a STOP signal after all the data has been transmitted. The following is an example showing how a stop condition is generated by a master transmitter.

```

MASTX    TST      TXCNT              ;GET VALUE FROM THE
          ;TRANSMITTING COUNTER
          BEQ      END                ;END IF NO MORE DATA
          BRSET    IBSR,#$01,END      ;END IF NO ACK
          MOVB     DATABUF,IBDR       ;TRANSMIT NEXT BYTE OF DATA
          DEC      TXCNT              ;DECREASE THE TXCNT
          BRA      EMASTX             ;EXIT
END       BCLR     IBCR,#$20          ;GENERATE A STOP CONDITION
EMASTX   RTI
  
```

If a master receiver wants to terminate a data transfer, it must inform the slave transmitter by not acknowledging the last byte of data which can be done by setting the transmit acknowledge bit (TXAK) before reading the 2nd last byte of data. Before reading the last byte of data, a STOP signal must be generated first. The following is an example showing how a STOP signal is generated by a master receiver.

```

MASR     DEC      RXCNT              ;DECREASE THE RXCNT
          BEQ      ENMASR             ;LAST BYTE TO BE READ
          MOVB     RXCNT,D1           ;CHECK SECOND LAST BYTE
          DEC      D1                 ;TO BE READ
          BNE      NXMAR              ;NOT LAST OR SECOND LAST
LAMAR    BSET     IBCR,#$08          ;SECOND LAST, DISABLE ACK
          ;TRANSMITTING
          BRA      NXMAR
ENMASR   BCLR     IBCR,#$20          ;LAST ONE, GENERATE 'STOP' SIGNAL
NXMAR    MOVB     IBDR,RXBUF         ;READ DATA AND STORE
          RTI
  
```

Inter-IC Bus (IIC)

Generation of Repeated START

At the end of data transfer, if the master still wants to communicate on the bus, it can generate another START signal followed by another slave address without first generating a STOP signal. A program example is as shown.

```

RESTART      BSET      IBCR,#$04      ANOTHER START (RESTART)
              MOVVB    CALLING,IBDR    ;TRANSMIT THE CALLING ADDRESS
              ;D0=R/W
    
```

Slave Mode

In the slave interrupt service routine, the module addressed as slave bit (IAAS) should be tested to check if a calling of its own address has just been received (see [Figure 90](#)). If IAAS is set, software should set the transmit/receive mode select bit (Tx/Rx̄ bit of IBCR) according to the R/W̄ command bit (SRW). Writing to the IBCR clears the IAAS automatically. Note that the only time IAAS is read as set is from the interrupt at the end of the address cycle where an address match occurred, interrupts resulting from subsequent data transfers will have IAAS cleared. A data transfer may now be initiated by writing information to IBDR, for slave transmits, or dummy reading from IBDR, in slave receive mode. The slave will drive SCL low in-between byte transfers, SCL is released when the IBDR is accessed in the required mode.

In slave transmitter routine, the received acknowledge bit (RXAK) must be tested before transmitting the next byte of data. Setting RXAK means an 'end of data' signal from the master receiver, after which it must be switched from transmitter mode to receiver mode by software. A dummy read then releases the SCL line so that the master can generate a STOP signal.

Arbitration Lost

If several masters try to engage the bus simultaneously, only one master wins and the others lose arbitration. The devices which lost arbitration are immediately switched to slave receive mode by the hardware. Their data output to the SDA line is stopped, but SCL is still generated until the end of the byte during which arbitration was lost. An interrupt occurs at the falling edge of the ninth clock of this transfer with $IBAL=1$ and $MS/\overline{SL}=0$. If one master attempts to start transmission while the bus is being engaged by another master, the hardware will inhibit the transmission; switch the MS/\overline{SL} bit from 1 to 0 without generating STOP condition; generate an interrupt to CPU and set the IBAL to indicate that the attempt to engage the bus is failed. When considering these cases, the slave service routine should test the IBAL first and the software should clear the IBAL bit if it is set.

Inter-IC Bus (IIC)

Freescale Semiconductor, Inc.

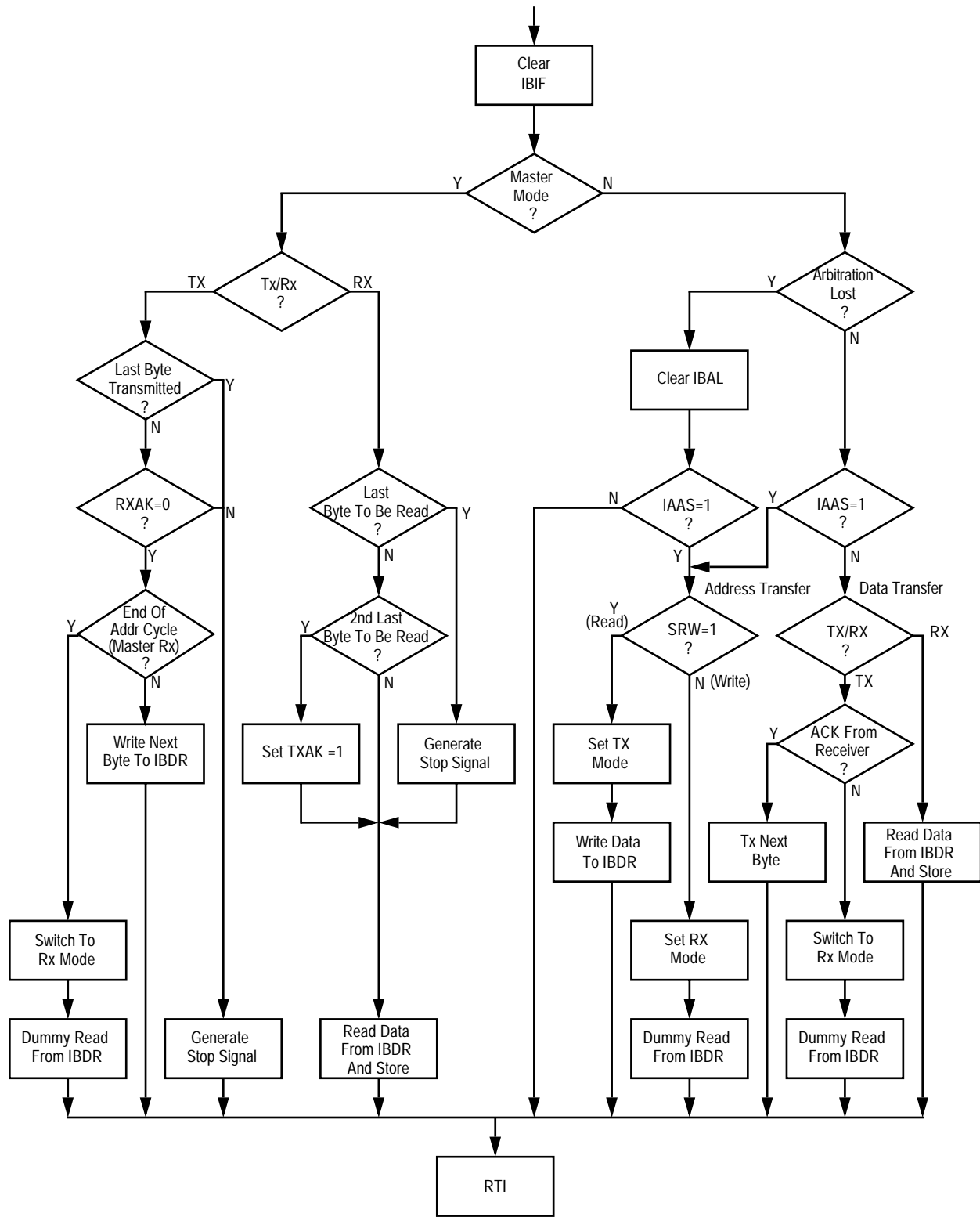

Figure 90 Flow-Chart of Typical I-Bus Interrupt Routine

Contents

Overview	491
Features	492
Block Diagram	493
External Pin Descriptions	494
Register Map	496
Functional Description	499
Register Descriptions	512
Modes of Operation	546
Low Power Options	547
Interrupt Operation	553

Overview

The Motorola Scalable Controller Area Network (MSCAN) definition is based on the MSCAN12 definition which is the specific implementation of the Motorola Scalable CAN concept targeted for the Motorola MC68HC12 Microcontroller Family.

The module is a communication controller implementing the CAN 2.0 A/B protocol as defined in the BOSCH specification dated September 1991. For users to fully understand the MSCAN specification, it is recommended that the Bosch specification be read first to familiarize the reader with the terms and concepts contained within this document.

The CAN protocol was primarily, but not only, designed to be used as a vehicle serial data bus, meeting the specific requirements of this field: real-time processing, reliable operation in the EMI environment of a vehicle, cost-effectiveness and required bandwidth.

MSCAN utilizes an advanced buffer arrangement resulting in a predictable real-time behavior and simplifies the application software.

Features

The basic features of the MSCAN are as follows:

- Modular architecture
- Implementation of the CAN protocol – Version 2.0A/B
 - Standard and extended data frames
 - 0–8 bytes data length
 - Programmable bit rate up to 1 Mbps¹
 - Support for remote frames
- 4 receive buffers with FIFO storage scheme
- 3 transmit buffers with internal prioritization using a ‘local priority’ concept
- Flexible maskable identifier filter supports two full size extended identifier filters (two 32-bit) or four 16-bit filters or eight 8-bit filters
- Programmable wake-up functionality with integrated low-pass filter
- Programmable loop back mode supports self-test operation
- Programmable listen-only mode for monitoring of CAN bus
- Separate signalling and interrupt capabilities for all CAN receiver and transmitter error states (Warning, Error Passive, Bus-Off)
- Programmable MSCAN clock source either system clock or crystal oscillator output
- Internal timer for time-stamping of received and transmitted messages
- Three low power modes: Sleep, Power Down and MSCAN Enable

1. Depending on the actual bit timing and the clock jitter of the PLL.

- Global initialization of configuration registers

Block Diagram

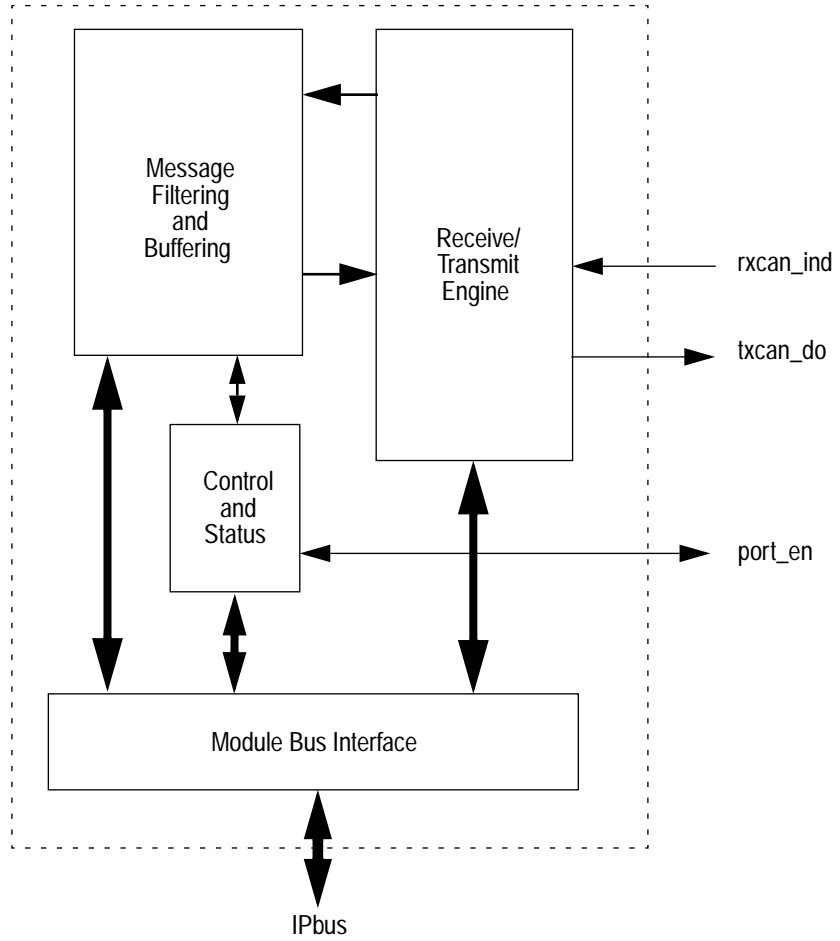

Figure 91 MSCAN Block Diagram

External Pin Descriptions

The MSCAN uses 2 external pins, 1 input (RxCAN) and 1 output (TxCAN). The TxCAN output pin represents the logic level on the CAN:

- '0' is for a dominant state
- '1' is for a recessive state

When the MSCAN is enabled (CANE=1) via the CANCTL1 register, the TxCAN and RxCAN pins will be enabled within the Port Module. This is indicated to Port Module using a dedicated enable line (ipp_port_en). When the MSCAN is disabled (CANE=0), these pins are available as general purpose I/O in the Port Module

A typical CAN system with MSCAN is shown in [Figure 92](#). Each CAN station is connected physically to the CAN bus lines through a transceiver chip. The transceiver is capable of driving the large current needed for the CAN bus and has current protection against defected CAN or defected stations.

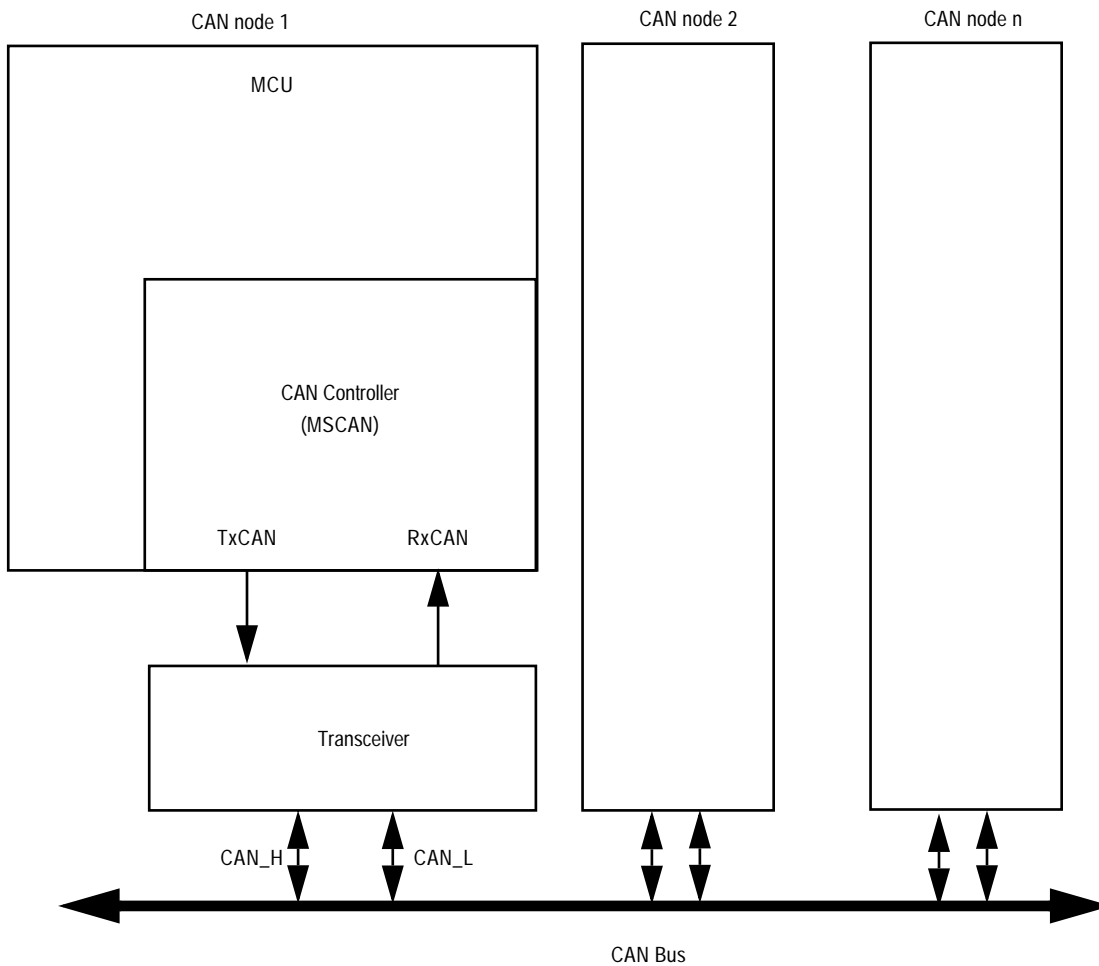

Figure 92 The CAN System

Register Map

The MSCAN occupies 64 bytes in the memory space. The base address of the MSCAN module is determined at the MCU level when the MCU is defined. The register decode map is fixed and begins at the first address of the module address offset.

Address Offset	
\$0000	CONTROL REGISTERS 12 BYTES
\$000B	
\$000C	RESERVED 2 BYTES
\$000D	
\$000E	ERROR COUNTERS 2 BYTES
\$000F	
\$0010	IDENTIFIER FILTER 16 BYTES
\$001F	
\$0020	RECEIVE BUFFER 16 BYTES (Window)
\$002F	
\$0030	TRANSMIT BUFFER 16 BYTES (Window)
\$003F	

Figure 93 MSCAN Register Organization

Figure 94 shows the individual registers associated with the MSCAN and their relative offset from the base address. The detailed register descriptions follow in the order they appear in the register map.

Reserved bits within a register always read as 0 and a write is unimplemented¹. Unimplemented functions are indicated by shading the bit.

Register name		Bit 7	6	5	4	3	2	1	Bit 0	Addr. Offset
CANCTL0	Read:	RXFRM	RXACT	CSWAI	SYNCH	TIME	WUPE	SLPRQ	INITRQ	\$0000
	Write:									
CANCTL1	Read:	CANE	CLKSRC	LOOPB	LISTEN	0	WUPM	SLPAK	INITAK	\$0001
	Write:									
CANBTR0	Read:	SJW1	SJW0	BRP5	BRP4	BRP3	BRP2	BRP1	BRP0	\$0002
	Write:									
CANBTR1	Read:	SAMP	TSEG22	TSEG21	TSEG20	TSEG13	TSEG12	TSEG11	TSEG10	\$0003
	Write:									
CANRFLG	Read:	WUPIF	CSCIF	RSTAT1	RSTAT0	TSTAT1	TSTAT0	OVRIF	RXF	\$0004
	Write:									
CANRIER	Read:	WUPIE	CSCIE	RSTATE1	RSTATE0	TSTATE1	TSTATE0	OVRIE	RXFIE	\$0005
	Write:									
CANTFLG	Read:	0	0	0	0	0	TXE2	TXE1	TXE0	\$0006
	Write:									
CANTIER	Read:	0	0	0	0	0	TXEIE2	TXEIE1	TXEIE0	\$0007
	Write:									
CANTARQ	Read:	0	0	0	0	0	ABTRQ2	ABTRQ1	ABTRQ0	\$0008
	Write:									
CANTAAK	Read:	0	0	0	0	0	ABTAK2	ABTAK1	ABTAK0	\$0009
	Write:									
CANTBSEL	Read:	0	0	0	0	0	TX2	TX1	TX0	\$000A
	Write:									
CANIDAC	Read:	0	0	IDAM1	IDAM0	0	IDHIT2	IDHIT1	IDHIT0	\$000B
	Write:									
RESERVED	Read:	0	0	0	0	0	0	0	0	\$000C -\$000D
	Write:									
CANRXERR	Read:	RXERR7	RXERR6	RXERR5	RXERR4	RXERR3	RXERR2	RXERR1	RXERR0	\$000E
	Write:									
CANTXERR	Read:	TXERR7	TXERR6	TXERR5	TXERR4	TXERR3	TXERR2	TXERR1	TXERR0	\$000F
	Write:									
CANIDAR0	Read:	AC7	AC6	AC5	AC4	AC3	AC2	AC1	AC0	\$0010
	Write:									

= Unimplemented

Figure 94 MSCAN Register Map

1. Reserved bits within the Tx- & Rx-Buffers (CANTXFG, CANRXFG) will be read as 'X', because of RAM based implementation.

MSCAN

Register name		Bit 7	6	5	4	3	2	1	Bit 0	Addr. Offset
CANIDAR1	Read: Write:	AC7	AC6	AC5	AC4	AC3	AC2	AC1	AC0	\$0011
CANIDAR2	Read: Write:	AC7	AC6	AC5	AC4	AC3	AC2	AC1	AC0	\$0012
CANIDAR3	Read: Write:	AC7	AC6	AC5	AC4	AC3	AC2	AC1	AC0	\$0013
CANIDMR0	Read: Write:	AM7	AM6	AM5	AM4	AM3	AM2	AM1	AM0	\$0014
CANIDMR1	Read: Write:	AM7	AM6	AM5	AM4	AM3	AM2	AM1	AM0	\$0015
CANIDMR2	Read: Write:	AM7	AM6	AM5	AM4	AM3	AM2	AM1	AM0	\$0016
CANIDMR3	Read: Write:	AM7	AM6	AM5	AM4	AM3	AM2	AM1	AM0	\$0017
CANIDAR4	Read: Write:	AC7	AC6	AC5	AC4	AC3	AC2	AC1	AC0	\$0018
CANIDAR5	Read: Write:	AC7	AC6	AC5	AC4	AC3	AC2	AC1	AC0	\$0019
CANIDAR6	Read: Write:	AC7	AC6	AC5	AC4	AC3	AC2	AC1	AC0	\$001A
CANIDAR7	Read: Write:	AC7	AC6	AC5	AC4	AC3	AC2	AC1	AC0	\$001B
CANIDMR4	Read: Write:	AM7	AM6	AM5	AM4	AM3	AM2	AM1	AM0	\$001C
CANIDMR5	Read: Write:	AM7	AM6	AM5	AM4	AM3	AM2	AM1	AM0	\$001D
CANIDMR6	Read: Write:	AM7	AM6	AM5	AM4	AM3	AM2	AM1	AM0	\$001E
CANIDMR7	Read: Write:	AM7	AM6	AM5	AM4	AM3	AM2	AM1	AM0	\$001F
CANRXFG	Read: Write:	FOREGROUND RECEIVE BUFFER								\$0020– \$002F
CANTXFG	Read: Write:	FOREGROUND TRANSMIT BUFFER								\$0030– \$003F

= Unimplemented

Figure 94 MSCAN Register Map

NOTE: Register Address = Base Address + Address Offset, where the Base Address is defined at the MCU level and the Address Offset is defined at the module level.

Functional Description

Message Storage MSCAN facilitates a sophisticated message storage system which addresses the requirements of a broad range of network applications.

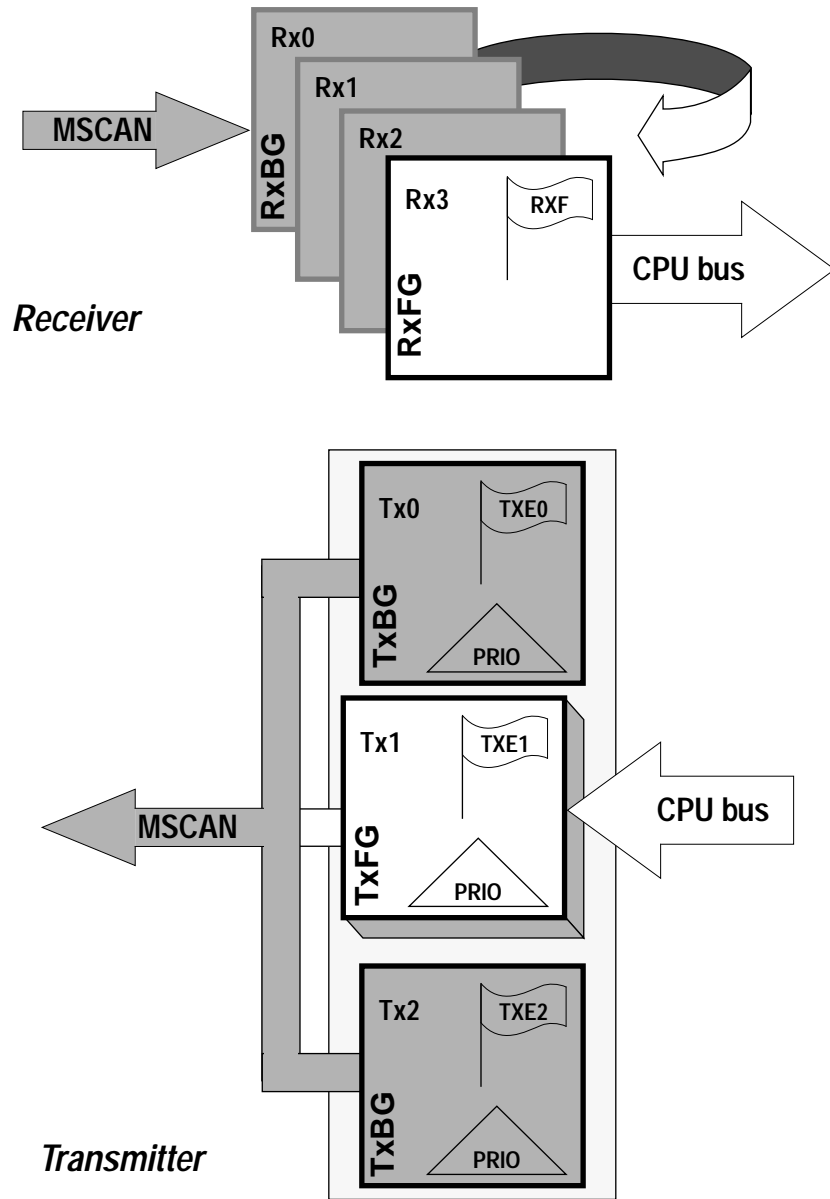

Figure 95 User Model for Message Buffer Organization

Message Transmit Background

Modern application layer software is built upon two fundamental assumptions:

1. Any CAN node is able to send out a stream of scheduled messages without releasing the bus between the two messages. Such nodes arbitrate for the bus immediately after sending the previous message and only release the bus in case of lost arbitration.
2. The internal message queue within any CAN node is organized such that the highest priority message is sent out first, if more than one message is ready to be sent.

The above behavior cannot be achieved with a single transmit buffer. That buffer must be reloaded right after the previous message is sent. This loading process lasts a finite amount of time and has to be completed within the Inter-Frame Sequence (IFS)¹ to be able to send an uninterrupted stream of messages. Even if this is feasible for limited CAN bus speeds, it requires that the CPU react with short latencies to the transmit interrupt.

A double buffer scheme de-couples the reloading of the transmit buffer from the actual message sending and, as such, reduces the reactivity requirements on the CPU. Problems can arise if the sending of a message is finished while the CPU re-loads the second buffer. No buffer would then be ready for transmission and the bus would be released.

At least three transmit buffers are required to meet the first of the above requirements under all circumstances. The MSCAN has three transmit buffers.

The second requirement calls for some sort of internal prioritization which the MSCAN implements with the 'local priority' concept described in [Transmit Structures](#).

Transmit Structures

The MSCAN has a triple transmit buffer scheme which allows multiple messages to be set up in advance and achieve an optimized real-time performance. The three buffers are arranged as shown in [Figure 95](#).

1. Reference the Bosch CAN 2.0A/B protocol specification dated September 1991.

All three buffers have a 13 byte data structure similar to the outline of the receive buffers (see [Programmer's Model of Message Storage](#)). An additional [Transmit Buffer Priority Register \(TBPR\)](#) contains an 8-bit 'Local Priority' field (PRIO). The remaining two bytes are used for time stamping of a message, if required (see [Time Stamp Register \(TSRH, TSRL\)](#)).

To transmit a message, the CPU has to identify an available transmit buffer which is indicated by a set Transmitter Buffer Empty (TXEx) flag (see [MSCAN Transmitter Flag Register \(CANTFLG\)](#)). If a transmit buffer is available, the CPU has to set a pointer to this buffer by writing to the CANTBSEL register (see [MSCAN Transmit Buffer Selection \(CANTBSEL\)](#)). This makes the respective buffer accessible within the CANTXFG address space (see [Programmer's Model of Message Storage](#)). The algorithmic feature associated with the CANTBSEL register simplifies the transmit buffer selection. In addition this scheme makes the handler software simpler as only one address area is applicable for the transmit process. In addition the required address space is minimized.

The CPU then stores the identifier, the control bits and the data content into one of the transmit buffers. Finally, the buffer is flagged as ready for transmission by clearing the associated TXE flag.

The MSCAN then schedules the message for transmission and signals the successful transmission of the buffer by setting the associated TXE flag. A transmit interrupt (see [Interrupt Operation](#)) is generated¹ when TXEx is set and can be used to drive the application software to re-load the buffer.

In case more than one buffer is scheduled for transmission when the CAN bus becomes available for arbitration, the MSCAN uses the 'local priority' setting of the three buffers to determine the prioritization. For this purpose, every transmit buffer has an 8-bit local priority field (PRIO). The application software programs this field when the message is set up. The local priority reflects the priority of this particular message relative to the set of messages being transmitted from this node. The lowest binary

1. The transmit interrupt occurs only if not masked. A polling scheme can be applied on TXEx also.

value of the PRIO field is defined to be the highest priority. The internal scheduling process takes place whenever the MSCAN arbitrates for the bus. This is also the case after the occurrence of a transmission error.

When a high priority message is scheduled by the application software, it may become necessary to abort a lower priority message in one of the three transmit buffers. As messages that are already in transmission cannot be aborted, the user has to request the abort by setting the corresponding Abort Request bit (ABTRQ) (see [MSCAN Transmitter Message Abort Control \(CANTARQ\)](#)). The MSCAN then grants the request, if possible, by: 1) setting the corresponding Abort Acknowledge flag (ABTAK) in the CANTAACK register, 2) setting the associated TXE flag to release the buffer, and 3) generating a transmit interrupt. The transmit interrupt handler software can tell from the setting of the ABTAK flag whether the message was aborted (ABTAK=1) or sent (ABTAK=0).

Receive Structures

The received messages are stored in a four stage input FIFO. The four message buffers are alternately mapped into a single memory area (see [User Model for Message Buffer Organization](#)). While the background receive buffer (RxBG) is exclusively associated with the MSCAN, the foreground receive buffer (RxFG) is addressable by the CPU (see [User Model for Message Buffer Organization](#)). This scheme simplifies the handler software as only one address area is applicable for the receive process.

All receive buffers have a size of 15 bytes to hold the CAN control bits, the identifier (standard or extended), the data contents and a time stamp, if enabled (for details see [Programmer's Model of Message Storage](#))¹.

The Receiver Full flag (RXF) (see [MSCAN Receiver Flag Register \(CANRFLG\)](#)) signals the status of the foreground receive buffer. When the buffer contains a correctly received message with a matching identifier, this flag is set.

On reception, each message is checked to see if it passes the filter (see [Identifier Acceptance Filter](#)) and in parallel, is written into the active

1. Reference the Bosch CAN 2.0A/B protocol specification dated September 1991 for details.

RxBG. After successful reception of a valid message the MSCAN shifts the content of RxBG into the receiver FIFO¹, sets the RXF flag, and generates a receive interrupt (see [Interrupt Operation](#)) to the CPU². The user's receive handler has to read the received message from the RxFG and then reset the RXF flag to acknowledge the interrupt and to release the foreground buffer. A new message, which can follow immediately after the IFS field of the CAN frame, is received into the next available RxBG. If the MSCAN receives an invalid message in its RxBG (wrong identifier, transmission errors etc.) the actual contents of the buffer will be over-written by the next message. The buffer will then not be shifted into the FIFO.

When the MSCAN module is transmitting, the MSCAN receives its own transmitted messages into the background receive buffer, RxBG, but does not shift it into the receiver FIFO, generate a receive interrupt, or acknowledge its own messages on the CAN bus. The exception to this rule is in loop back mode (see [MSCAN Control 1 Register \(CANCTL1\)](#)) where the MSCAN treats its own messages exactly like all other incoming messages. The MSCAN receives its own transmitted messages in the event that it loses arbitration³. If arbitration is lost, the MSCAN must be prepared to become a receiver.

An overrun condition occurs when all receive message buffers in the FIFO are filled with correctly received messages with accepted identifiers and another message is correctly received from the bus with an accepted identifier. The latter message is discarded and an error interrupt with overrun indication is generated if enabled (see [Interrupt Operation](#)). The MSCAN is still able to transmit messages while the receiver FIFO being filled, but all incoming messages are discarded. As soon as a receive buffer in the FIFO is available again, new valid messages will be accepted.

1. As long as the FIFO Buffer is not completely filled.

2. The receive interrupt occurs only if not masked. A polling scheme can be applied on RXF also.

3. Reference the Bosch CAN 2.0A/B protocol specification dated September 1991 for details.

**Identifier
Acceptance Filter**

The MSCAN Identifier Acceptance Registers (see [MSCAN Identifier Acceptance Registers \(CANIDAR0–7\)](#)) define the acceptable patterns of the standard or extended identifier (ID10–ID0 or ID28–ID0). Any of these bits can be marked ‘don’t care’ in the MSCAN Identifier Mask Registers (see [MSCAN Identifier Mask Registers \(CANIDMR0–7\)](#)).

A filter hit is indicated to the application software by a set Receive Buffer Full flag (RXF=1) and three bits in the CANIDAC register (see [MSCAN Identifier Acceptance Control Register \(CANIDAC\)](#)). These Identifier Hit flags (IDHIT2–0) clearly identify the filter section that caused the acceptance. They simplify the application software’s task to identify the cause of the receiver interrupt. In case more than one hit occurs (two or more filters match), the lower hit has priority.

A very flexible programmable generic identifier acceptance filter has been introduced to reduce the CPU interrupt loading. The filter is programmable to operate in four different modes¹:

- Two identifier acceptance filters, each to be applied to a) the full 29 bits of the extended identifier and to the following bits of the CAN 2.0B frame: Remote Transmission Request (RTR), Identifier Extension (IDE), and Substitute Remote Request (SRR) or b)² the 11 bits of the standard identifier plus the RTR and IDE bits of the CAN 2.0A/B messages. This mode implements two filters for a full length CAN 2.0B compliant extended identifier. [Figure 96](#) shows how the first 32-bit filter bank (CANIDAR0–3, CANIDMR0–3) produces a filter 0 hit. Similarly, the second filter bank (CANIDAR4–7, CANIDMR4–7) produces a filter 1 hit.
- Four identifier acceptance filters, each to be applied to a) the 14 most significant bits of the extended identifier plus the SRR and IDE bits of CAN 2.0B messages or b) the 11 bits of the standard identifier, the RTR and IDE bits of CAN 2.0A/B messages. [Figure 97](#) shows how the first 32-bit filter bank (CANIDAR0–3,

1. For a better understanding of references made within the filter mode description, reference the Bosch specification dated September 1991 which details the CAN 2.0A/B protocol.

2. Although this mode can be used for standard identifiers, it is recommended to use the four or eight identifier acceptance filters for standard identifiers

CANIDMR0–3) produces filter 0 and 1 hits. Similarly, the second filter bank (CANIDAR4–7, CANIDMR4–7) produces filter 2 and 3 hits.

- Eight identifier acceptance filters, each to be applied to the first 8 bits of the identifier. This mode implements eight independent filters for the first 8 bits of a CAN 2.0A/B compliant standard identifier or a CAN 2.0B compliant extended identifier. [Figure 98](#) shows how the first 32-bit filter bank (CANIDAR0–3, CANIDMR0–3) produces filter 0 to 3 hits. Similarly, the second filter bank (CANIDAR4–7, CANIDMR4–7) produces filter 4 to 7 hits.
- Closed filter. No CAN message is copied into the foreground buffer RxFG, and the RXF flag is never set.

MSCAN

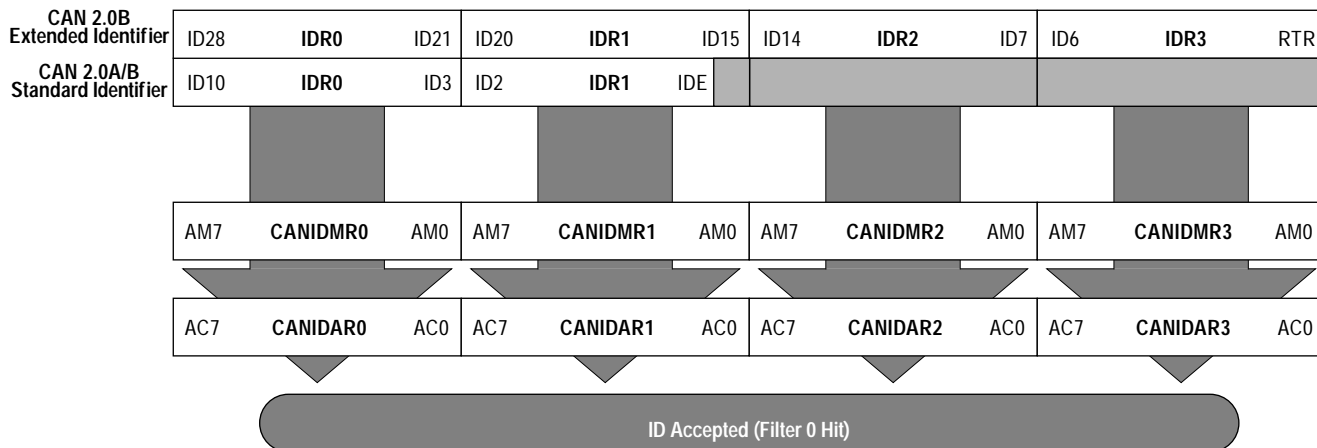

Figure 96 32-bit Maskable Identifier Acceptance Filter

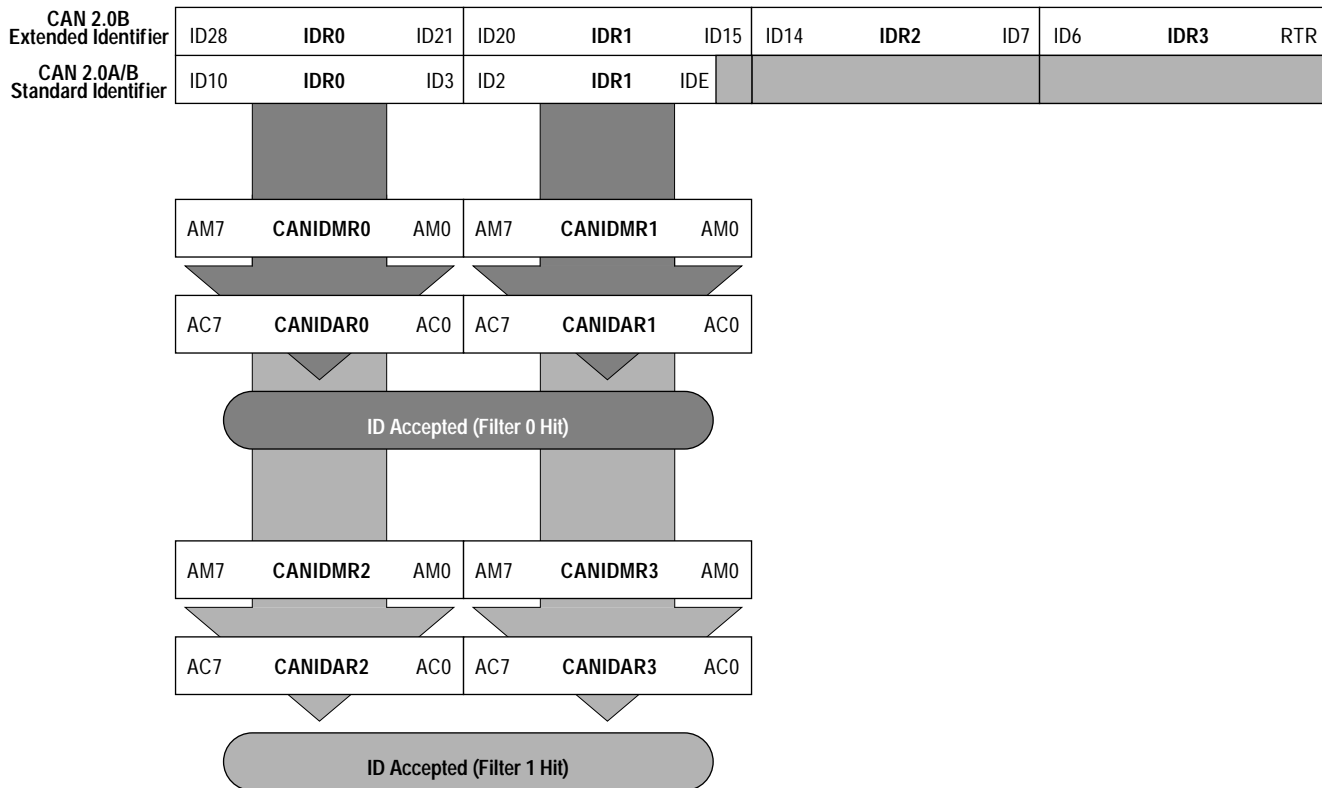

Figure 97 16-bit Maskable Identifier Acceptance Filters

CAN 2.0B Extended Identifier	ID28	IDR0	ID21	ID20	IDR1	ID15	ID14	IDR2	ID7	ID6	IDR3	RTR
CAN 2.0A/B Standard Identifier	ID10	IDR0	ID3	ID2	IDR1	IDE						

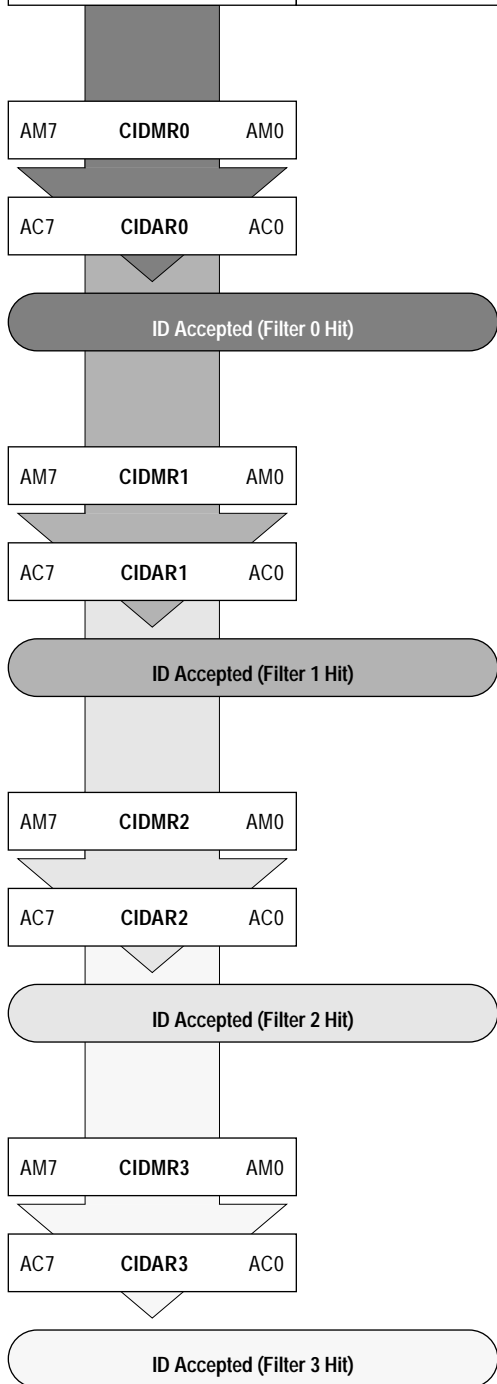

Figure 98 8-bit Maskable Identifier Acceptance Filters

MSCAN

Protocol Violation Protection

The MSCAN protects the user from accidentally violating the CAN protocol through programming errors. The protection logic implements the following features:

- The receive and transmit error counters cannot be written or otherwise manipulated.
- All registers which control the configuration of the MSCAN cannot be modified while the MSCAN is on-line. The MSCAN has to be in Initialization Mode. The corresponding INITRQ/INITAK handshake bits in the CANCTL0/CANCTL1 registers (see [MSCAN Control 0 Register \(CANCTL0\)](#)) serve as a lock to protect the following registers:
 - MSCAN Control 1 Register (CANCTL1)
 - MSCAN Bus Timing Registers 0 and 1 (CANBTR0, CANBTR1)
 - MSCAN Identifier Acceptance Control Register (CANIDAC)
 - MSCAN Identifier Acceptance Registers (CANIDAR0–7)
 - MSCAN Identifier Mask Registers (CANIDMR0–7)
- The TxCAN pin is immediately forced to a recessive state when the MSCAN goes into the Power Down Mode or Initialization Mode (see [MSCAN Power Down Mode](#) and [MSCAN Initialization Mode](#)).
- The MSCAN enable bit (CANE) is only writable once in normal modes as further protection against inadvertently disabling the MSCAN.

Clock System

[Figure 99](#) shows the structure of the MSCAN clock generation circuitry. With this flexible clocking scheme, the MSCAN is able to handle CAN bus rates ranging from 10 Kbps up to 1 Mbps.

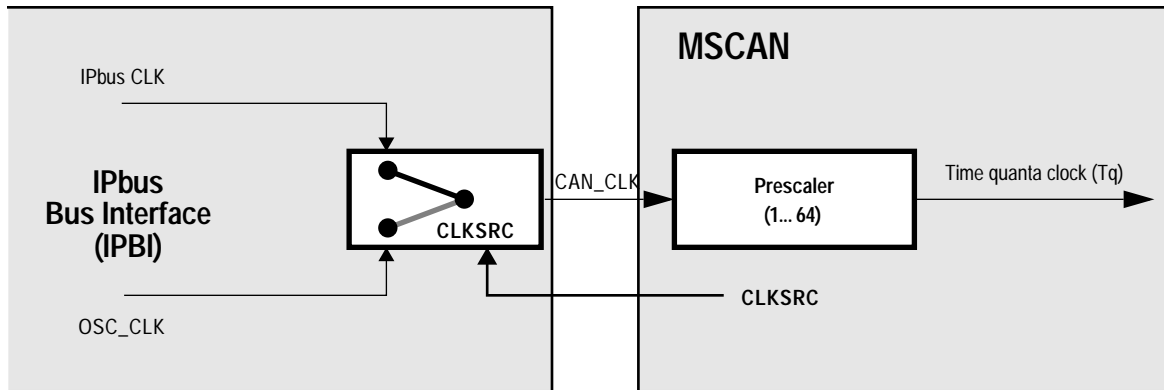

Figure 99 MSCAN Clocking Scheme

The Clock Source bit (CLKSRC) in the CANCTL1 register (see [MSCAN Control 1 Register \(CANCTL1\)](#)) defines whether the internal CAN_CLK is connected to the output of a crystal oscillator (OSC_CLK) or to the IPbus bus clock (CLK).

The clock source has to be chosen such that the tight oscillator tolerance requirements (up to 0.4%) of the CAN protocol are met. Additionally, for high CAN bus rates (1 Mbps), a 45%-55% duty cycle of the clock is required.

NOTE: *If the system clock is generated from a PLL, it is recommended to select the crystal clock source rather than the system clock source due to jitter considerations, especially at the faster CAN bus rates.*

For microcontrollers without a clock and reset generator (CRG), CAN_CLK is driven from the crystal oscillator (OSC_CLK).

A programmable prescaler generates the time quanta (Tq) clock from CAN_CLK. A time quantum is the atomic unit of time handled by the MSCAN.

$$f_{Tq} = \frac{f_{CANCLK}}{(\text{Prescaler value})}$$

A bit time is subdivided into three segments^{1 2} (see [Figure 100](#)):

- SYNC_SEG: This segment has a fixed length of one time quantum. Signal edges are expected to happen within this section.
- Time Segment 1: This segment includes the PROP_SEG and the PHASE_SEG1 of the CAN standard. It can be programmed by setting the parameter TSEG1 to consist of 4 to 16 time quanta.
- Time Segment 2: This segment represents the PHASE_SEG2 of the CAN standard. It can be programmed by setting the TSEG2 parameter to be 2 to 8 time quanta long.

$$\text{Bit Rate} = \frac{f_{Tq}}{\text{(number of Time Quanta)}}$$

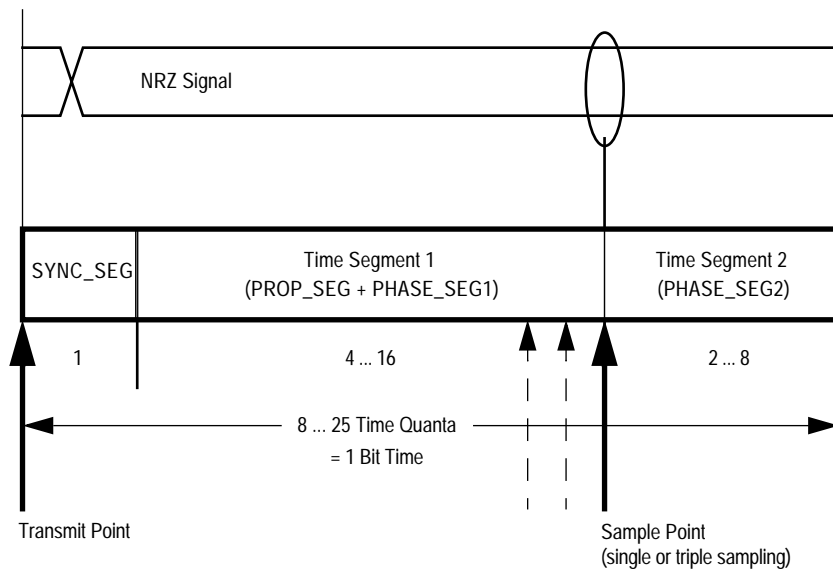

Figure 100 Segments within the Bit Time

1. For further explanation of the under-lying concepts please refer to ISO/DIS 11519-1, Section 10.3.
2. Reference the Bosch CAN 2.0A/B protocol specification dated September 1991 for bit timing.

Table 86 Time Segment Syntax

Syntax	Description
SYNC_SEG	System expects transitions to occur on the bus during this period.
Transmit Point	A node in transmit mode transfers a new value to the CAN bus at this point.
Sample Point	A node in receive mode samples the bus at this point. If the three samples per bit option is selected, then this point marks the position of the third sample.

The Synchronization Jump Width¹ can be programmed in a range of 1 to 4 time quanta by setting the SJW parameter.

The above parameters are set by programming the MSCAN Bus Timing Registers (CANBTR0, CANBTR1) (see [MSCAN Bus Timing Register 0 \(CANBTR0\)](#) and [MSCAN Bus Timing Register 1 \(CANBTR1\)](#)).

[Figure 101](#) gives an overview of the CAN compliant segment settings and the related parameter values.

NOTE: *It is the user's responsibility to ensure the bit time settings are in compliance with the CAN standard.*

Time Segment 1	TSEG1	Time Segment 2	TSEG2	Synchronization Jump Width	SJW
5 .. 10	4 .. 9	2	1	1 .. 2	0 .. 1
4 .. 11	3 .. 10	3	2	1 .. 3	0 .. 2
5 .. 12	4 .. 11	4	3	1 .. 4	0 .. 3
6 .. 13	5 .. 12	5	4	1 .. 4	0 .. 3
7 .. 14	6 .. 13	6	5	1 .. 4	0 .. 3
8 .. 15	7 .. 14	7	6	1 .. 4	0 .. 3
9 .. 16	8 .. 15	8	7	1 .. 4	0 .. 3

Figure 101 CAN Standard Compliant Bit Time Segment Settings

1. Reference the Bosch CAN 2.0A/B protocol specification dated September 1991 for bit timing.

Timer Stamp

The MSCAN generates an internal time stamp whenever a valid frame is received or transmitted and the TIME bit is enabled. Because the CAN specification defines a frame to be valid if no errors occur before the End of Frame (EOF) field is transmitted successfully, the actual value of an internal timer is written at EOF to the appropriate time stamp position within the transmit buffer. For receive frames the time stamp is written to the receive buffer.

Register Descriptions

This section describes in detail all the registers and register bits in the MSCAN module.

NOTE: *All bits of all registers in this module are completely synchronous to internal clocks during a register read.*

Programmer's Model of Control Registers

The programmer's model is laid out for maximum simplicity and efficiency. The [Register Map](#) provides an overview of the control registers for the MSCAN.

MSCAN Control 0 Register (CANCTL0)

The CANCTL0 register provides for various control of the MSCAN module as described below.

Address Offset: \$0000

	Bit 7	6	5	4	3	2	1	Bit 0
Read:	RXFRM	RXACT	CSWAI	SYNCH	TIME	WUPE	SLPRQ	INITRQ
Write:								
Reset:	0	0	0	0	0	0	0	1

= Unimplemented

NOTE: *The CANCTL0 register, except the WUPE, INITRQ and SLPRQ bits, is held in the reset state when the Initialization Mode is active (INITRQ=1 and INITAK=1). This register is writable again as soon as the Initialization Mode is left (INITRQ=0 and INITAK=0).*

Read: anytime

Write: anytime when out of initialization; exceptions are bits RXACT and SYNCH which are read-only and bit RXFRM which is set by the module. A write of '1' to the RXFRM register clears the flag and a write of '0' is ignored

RXFRM — Received Frame Flag

This bit is read and clear only. It is set when a receiver has received a valid message correctly, independently of the filter configuration. Once set, it remains set until cleared by software or reset. Clearing is done by writing a '1' to the bit. This bit is not valid in loop back mode.

1 = A valid message was received since last clearing of this flag
0 = No valid message was received since last clearing this flag.

NOTE: *The MSCAN must be in run mode for this bit to become set.*

RXACT — Receiver Active Status

This flag indicates the MSCAN is receiving a message. The flag is controlled by the receiver front end. This bit is not valid in loop back mode.

1 = MSCAN is receiving a message (including when arbitration is lost)¹
0 = MSCAN is transmitting or idle¹.

CSWAI — CAN Stops in Wait Mode

Enabling this bit allows for lower power consumption in Wait Mode by disabling all the clocks at the bus interface to the MSCAN module.

1 = The module ceases to be clocked during WAIT mode.
0 = The module is not affected during WAIT mode.

CAUTION: *In order to protect from accidentally violating the CAN protocol the TxCAN pin is immediately forced to a recessive state when the MCU enters Wait (CSWAI=1) or Stop Mode (see [MSCAN Power Down Mode](#))*

1. See the Bosch CAN 2.0A/B protocol specification dated September 1991 for a detailed definition of transmitter and receiver states.

SYNCH — Synchronized Status

This flag indicates whether the MSCAN is synchronized to the CAN bus and, as such, can participate in the communication process. It is set and cleared by the MSCAN.

1 = MSCAN is synchronized to the CAN bus.

0 = MSCAN is not synchronized to the CAN bus.

TIME — Timer Enable

This bit activates an internal 16-bit wide free running timer which is clocked by the bit clock. If the timer is enabled, a 16-bit time stamp will be assigned to each transmitted/received message within the active Tx/Rx buffer. As soon as a message is acknowledged on CAN, the time stamp will be written to the highest bytes (\$_E, \$_F) in the appropriate buffer (see [Programmer's Model of Message Storage](#)). The internal timer is reset (all bits set to '0') when Initialization Mode is active.

1 = Enable internal MSCAN timer.

0 = Disable internal MSCAN timer.

WUPE — Wake-Up Enable

This configuration bit allows the MSCAN to restart when being locked in idle state during Sleep Mode and traffic on CAN is detected (see [MSCAN Sleep Mode](#)).

1 = Wake-Up enabled – The MSCAN is able to restart.

0 = Wake-Up disabled – The MSCAN ignores traffic on CAN.

CAUTION: *The CPU has to make sure that the wake-up option WUPE register is enabled, if the recovery mechanism from STOP or WAIT is required.*

SLPRQ — Sleep Mode Request

This bit requests the MSCAN to enter Sleep Mode, which is an internal power saving mode (see [MSCAN Sleep Mode](#)). If a message transfer on CAN is ongoing when receiving this request, MSCAN will wait until end of current message before entering Sleep Mode. The module indicates entry to Sleep Mode by setting SLPK=1 (see [MSCAN Control 1 Register \(CANCTL1\)](#)). Sleep Mode will be active

until SLPRQ is cleared by the CPU or, depending on the setting of WUPE bit, the MSCAN detects bus activity on CAN and clears the SLPRQ itself.

- 1 = Sleep Mode Request – The MSCAN locks in idle state.
- 0 = Running – The MSCAN functions normally.

NOTE: *The MCU cannot clear the SLPRQ bit before the MSCAN has entered Sleep Mode (SLPRQ=1 and SLPAK=1)*

INITRQ — Initialization Mode Request

When this bit is set by the CPU, the MSCAN skips to Initialization Mode (see [MSCAN Initialization Mode](#)). Any ongoing transmission or reception is aborted and synchronization to the bus is lost. The module indicates entry to Initialization Mode by setting INITAK=1 (see [MSCAN Control 1 Register \(CANCTL1\)](#)).

The following registers enter their hard reset state and restore their default values: CANCTL0¹, CANRFLG², CANRIER³, CANTFLG, CANTIER, CANTARQ, CANTAACK, CANTBSEL.

The registers CANCTL1, CANBTR0, CANBTR1, CANIDAC, CANIDAR0–7, CANIDMR0–7 can only be written by the CPU when the MSCAN is in Initialization Mode (INITRQ=1 and INITAK=1). The values of the error counters are not affected by initialization.

When this bit is cleared by the CPU, the MSCAN restarts and then tries to synchronize to the CAN bus. If the MSCAN is not in bus-off state, it synchronizes after 11 consecutive recessive bits on the bus; if the MSCAN is in bus-off state it continues to wait for 128 occurrences of 11 consecutive recessive bits.

Writing to other bits in CANCTL0, CANRFLG, CANRIER, CANTFLG or CANTIER must only be done after Initialization Mode is left, which is INITRQ=0 and INITAK=0.

- 1 = MSCAN in initialization state.
- 0 = Normal operation.

1. except the INITRQ and SLPRQ bits
 2. The TSTAT1, TSTAT0 bits are not affected by Initialization Mode
 3. The RSTAT1, RSTAT0 bits are not affected by Initialization Mode

MSCAN

NOTE: The MCU cannot clear the INITRQ bit before the MSCAN has entered Initialization Mode (INITRQ=1 and INITAK=1)

CAUTION: In order to protect from accidentally violating the CAN protocol the TxCAN pin is immediately forced to a recessive state when the Initialization Mode is requested by the MCU. Thus the recommended procedure is to bring the MSCAN into Sleep Mode (SLPRQ=1 and SLPAK=1) before.

MSCAN Control 1 Register (CANCTL1)

The CANCTL1 register provides for various control and handshake status information of the MSCAN module as described below.

Address Offset: \$0001

	Bit 7	6	5	4	3	2	1	Bit 0
Read:	CANE	CLKSRC	LOOPB	LISTEN	0	WUPM	SLPAK	INITAK
Write:								
Reset:	0	0	0	1	0	0	0	1

= Unimplemented

Read: anytime

Write: anytime when INITRQ=1 and INITAK=1, except CANE which is write once in normal modes and anytime in special modes when the MSCAN is in Initialization Mode (INITRQ=1 and INITAK=1).

CANE — MSCAN Enable

- 1 = The MSCAN module is enabled.
- 0 = The MSCAN module is disabled.

CLKSRC — MSCAN Clock Source

This bit defines the clock source for the MSCAN module (only for systems with a system clock generation module; see [Clock System](#) and [Figure 99](#)).

- 1 = The MSCAN clock source is the ungated IPbus clock (CLK).
- 0 = The MSCAN clock source is the oscillator clock (OSC_CLK).

LOOPB — Loop Back Self Test Mode

When this bit is set, the MSCAN performs an internal loop back which can be used for self test operation. The bit stream output of the transmitter is fed back to the receiver internally. The RxCAN input pin is ignored and the TxCAN output goes to the recessive state (logic '1'). The MSCAN behaves as it does normally when transmitting and treats its own transmitted message as a message received from a remote node. In this state, the MSCAN ignores the bit sent during the ACK slot in the CAN frame Acknowledge field to ensure proper reception of its own message. Both transmit and receive interrupts are generated.

LISTEN — Listen Only Mode

This bit configures the MSCAN as a bus monitor. When the bit is set, all valid CAN messages with matching ID are received, but no acknowledgement or error frames are sent out (see [Listen-Only Mode](#)). In addition the error counters are frozen. Listen Only Mode supports applications which require 'hot plugging' or throughput analysis. The MSCAN is unable to transmit any messages, when Listen Only Mode is active.

- 1 = Listen Only Mode activated
- 0 = normal operation

WUPM — Wake-Up Mode

This bit defines whether the integrated low-pass filter is applied to protect the MSCAN from spurious wake-up (see [MSCAN Sleep Mode](#)).

- 1 = MSCAN wakes-up the CPU only in case of a dominant pulse on the bus which has a length of T_{wup} and WUPE=1 in CANCTL0 (see [MSCAN Control 0 Register \(CANCTL0\)](#)).
- 0 = MSCAN wakes-up the CPU after any recessive to dominant edge on the CAN bus and WUPE=1 in CANCTL0.

SLPAK — Sleep Mode Acknowledge

This flag indicates whether the MSCAN module has entered Sleep Mode (see [MSCAN Sleep Mode](#)). It is used as a handshake flag for the SLPRQ Sleep Mode request. Sleep Mode is active when

INITRQ=1 and INITAK=1. Depending on the setting of the WUPE bit the MSCAN will clear the flag if it detects bus activity on CAN while in Sleep Mode.

- 1 = Sleep Mode Active – The MSCAN has entered Sleep Mode.
- 0 = Running – The MSCAN operates normally.

INITAK — Initialization Mode Acknowledge

This flag indicates whether the MSCAN module is in Initialization Mode (see [MSCAN Initialization Mode](#)). It is used as a handshake flag for the INITRQ Initialization Mode request. Initialization Mode is active when INITRQ=1 and INITAK=1.

The registers CANCTL1, CANBTR0, CANBTR1, CANIDAC, CANIDAR0–7, CANIDMR0–7 can only be written by the CPU when the MSCAN is in Initialization Mode.

- 1 = Initialization Mode Active – The MSCAN has entered Initialization Mode.
- 0 = Running – The MSCAN operates normally.

MSCAN Bus Timing Register 0 (CANBTR0)

The CANBTR0 register provides for various bus timing control of the MSCAN module as described below.

Address Offset: \$0002

	Bit 7	6	5	4	3	2	1	Bit 0
Read:	SJW1	SJW0	BRP5	BRP4	BRP3	BRP2	BRP1	BRP0
Write:								
Reset:	0	0	0	0	0	0	0	0

Read: anytime

Write: anytime in Initialization Mode (INITRQ=1 and INITAK=1)

SJW1, SJW0 — Synchronization Jump Width

The synchronization jump width defines the maximum number of time quanta (Tq) clock cycles a bit can be shortened or lengthened to achieve resynchronization to data transitions on the bus (see [Table 87](#)).

Table 87 Synchronization Jump Width

SJW1	SJW0	Synchronization jump width
0	0	1 Tq clock cycle
0	1	2 Tq clock cycles
1	0	3 Tq clock cycles
1	1	4 Tq clock cycles

BRP[5–0] — Baud Rate Prescaler

These bits determine the time quanta (Tq) clock which is used to build up the individual bit timing, as shown in [Table 88](#).

Table 88 Baud Rate Prescaler

BRP5	BRP4	BRP3	BRP2	BRP1	BRP0	Prescaler value (P)
0	0	0	0	0	0	1
0	0	0	0	0	1	2
0	0	0	0	1	0	3
0	0	0	0	1	1	4
:	:	:	:	:	:	:
1	1	1	1	1	0	63
1	1	1	1	1	1	64

MSCAN

MSCAN Bus Timing Register 1 (CANBTR1)

The CANBTR1 register provides for various bus timing control of the MSCAN module as described below.

Address Offset: \$0003

	Bit 7	6	5	4	3	2	1	Bit 0
Read:	SAMP	TSEG22	TSEG21	TSEG20	TSEG13	TSEG12	TSEG11	TSEG10
Write:								
Reset:	0	0	0	0	0	0	0	0

Read: anytime

Write: anytime in Initialization Mode (INITRQ=1 and INITAK=1)

SAMP — Sampling

This bit determines the number of samples of the serial bus to be taken per bit time. If set, three samples per bit are taken; the regular one (sample point) and two preceding samples using a majority rule. For higher bit rates, it is recommended that SAMP be cleared which means that only one sample is taken per bit.

1 = Three samples per bit¹.

0 = One sample per bit.

TSEG22–TSEG20 — Time Segment 2

Time segments within the bit time fix the number of clock cycles per bit time and the location of the sample point (see [Figure 100](#)).

Time segment 2 (TSEG2) values are programmable as shown in [Table 89](#).

1. In this case, PHASE_SEG1 must be at least 2 Time Quanta.

Table 89 Time Segment 2 Values

TSEG22	TSEG21	TSEG20	Time segment 2
0	0	0	1 Tq clock cycle ⁽¹⁾
0	0	1	2 Tq clock cycles
.	.	.	.
1	1	0	7 Tq clock cycles
1	1	1	8 Tq clock cycles

1. This setting is not valid. Please refer to [Figure 101](#) for valid settings.

TSEG13–TSEG10 — Time Segment 1

Time segments within the bit time fix the number of clock cycles per bit time and the location of the sample point (see [Figure 100](#)).

Time segment 1 (TSEG1) values are programmable as shown in [Table 90](#).

Table 90 Time Segment 1 Values

TSEG13	TSEG12	TSEG11	TSEG10	Time segment 1
0	0	0	0	1 Tq clock cycle ⁽¹⁾
0	0	0	1	2 Tq clock cycles ¹
0	0	1	0	3 Tq clock cycles ¹
0	0	1	1	4 Tq clock cycles
.
1	1	1	0	15 Tq clock cycles
1	1	1	1	16 Tq clock cycles

1. This setting is not valid. Please refer to [Figure 101](#) for valid settings.

The bit time is determined by the oscillator frequency, the baud rate prescaler, and the number of time quanta (Tq) clock cycles per bit (as shown in [Table 89](#) and [Table 90](#) above).

$$\text{Bit Time} = \frac{(\text{Prescaler value})}{f_{\text{CANCLK}}} \cdot (\text{number of Time Quanta})$$

MSCAN

MSCAN Receiver
Flag Register
(CANRFLG)

A flag can only be cleared when the condition which caused the setting is no longer valid and can only be cleared by software (writing a '1' to the corresponding bit position). Every flag has an associated interrupt enable bit in the CANRIER register.

Address Offset: \$0004

	Bit 7	6	5	4	3	2	1	Bit 0
Read:	WUPIF	CSCIF	RSTAT1	RSTAT0	TSTAT1	TSTAT0	OVRIFF	RXF
Write:								
Reset:	0	0	0	0	0	0	0	0

NOTE: The CANRFLG register is held in the reset state¹ when the Initialization Mode is active (INITRQ=1 and INITAK=1). This register is writable again as soon as the Initialization Mode is left (INITRQ=0 and INITAK=0).

Read: anytime

Write: anytime when out of Initialization Mode, except RSTAT[1:0] & TSTAT[1:0] flags which are read only; write of '1' clears flag; write of '0' ignored

WUPIF — Wake-up Interrupt Flag

If the MSCAN detects bus activity while in Sleep Mode (see [MSCAN Sleep Mode](#)) and the WUPE=1 in CANTCTL0 (see [MSCAN Control 0 Register \(CANCTL0\)](#)), it will set the WUPIF flag. If not masked, a Wake-Up interrupt is pending while this flag is set.

- 1 = MSCAN detected activity on the bus and requested wake-up.
- 0 = No wake-up activity observed while in Sleep Mode.

CSCIF — CAN Status Change Interrupt Flag

This flag is set when the MSCAN changes its current bus status due to the actual value of the Transmit Error Counter (TEC) and the Receive Error Counter (REC). An additional 4-bit (RSTAT[1:0], TSTAT[1:0]) status register, which is split into separate sections for TEC/REC, informs the system on the actual bus status (see [MSCAN Receiver Interrupt Enable Register \(CANRIER\)](#)). If not masked, an Error interrupt is pending while this flag is set. CSCIF provides a

1. The RSTAT[1:0, TSTAT[1:0] bits are not affected by Initialization Mode

blocking interrupt. That guarantees that the Receiver / Transmitter status bits (RSTAT/TSTAT) are only updated when no CAN Status Change interrupt is pending. If the TECs/RECs change their current value after the CSCIF is asserted and therefore would cause an additional state change in the RSTAT/TSTAT bits, these bits keep their old state bits until the current CSCIF interrupt is cleared again.

1 = MSCAN changed current bus status.

0 = No change in bus status occurred since last interrupt.

RSTAT1–RSTAT0 — Receiver Status Bits

The values of the Error Counters control the actual bus status of the MSCAN. As soon as the Status Change Interrupt Flag (CSCIF) is set these bits indicate the appropriate receiver related bus status of the MSCAN. The coding for the bits RSTAT1, RSTAT0 is:

11 = BusOff¹: 255 > Transmit Error Counter

10 = RxERR: 127 < Receive Error Counter

01 = RxWRN: 96 < Receive Error Counter ≤ 127

00 = RxOK: 0 ≤ Receive Error Counter ≤ 96

TSTAT1–TSTAT0 — Transmitter Status Bits

The values of the Error Counters control the actual bus status of the MSCAN. As soon as the Status Change Interrupt Flag (CSCIF) is set these bits indicate the appropriate transmitter related bus status of the MSCAN. The coding for the bits TSTAT1, TSTAT0 is:

11 = BusOff: 255 > Transmit Error Counter

10 = TxERR: 127 < Transmit Error Counter ≤ 255

01 = TxWRN: 96 < Transmit Error Counter ≤ 127

00 = TxOK: 0 ≤ Transmit Error Counter ≤ 96

OVRIF — Overrun Interrupt Flag

This flag is set when a data overrun condition occurs. If not masked, an Error interrupt is pending while this flag is set.

1 = A data overrun detected.

0 = No data overrun condition.

1. Redundant Information for the most critical bus status which is 'CAN BusOff'. This only occurs if the Tx Error Counter exceeds a number of 255 errors. CAN Bus Off affects the receiver state. As soon as the transmitter leaves its Bus Off state the receiver state skips to RxOK too. Refer also to TSTAT[1:0] coding.

RXF — Receive Buffer Full

The RXF flag is set by the MSCAN when a new message is available in the receiver FIFO. This flag indicates whether the shifted buffer is loaded with a correctly received message (matching identifier, matching Cyclic Redundancy Code (CRC) and no other errors detected). After the CPU has read that message from the RxFG buffer in the receiver FIFO, the RXF flag must be cleared to release the buffer. Depending on the clocking relationship between CAN and CPU clock domain the time until the RXF flag gets asserted again will vary¹. A set RXF flag prohibits the shifting of the next FIFO entry into the foreground buffer (RxFG). If not masked, a Receive interrupt is pending while this flag is set.

- 1 = The receiver FIFO is not empty. A new message is available in the RxFG.
- 0 = No new message available within the RxFG.

WARNING: *To ensure data integrity, do not read the receive buffer registers while the RXF flag is cleared.*

MSCAN Receiver Interrupt Enable Register (CANRIER)

This register contains the interrupt enable bits for the interrupt flags described above.

Address Offset: \$0005

	Bit 7	6	5	4	3	2	1	Bit 0
Read:	WUPIE	CSCIE	RSTATE1	RSTATE0	TSTATE1	TSTATE0	OVRIE	RXFIE
Write:								
Reset:	0	0	0	0	0	0	0	0

NOTE: *The CANRIER register is held in the reset state² when the Initialization Mode is active (INITRQ=1 and INITAK=1). This register is writable again as soon as the Initialization Mode is left (INITRQ=0 and INITAK=0).*

1. In case there is another CAN message in the FIFO buffer.
 2. The RSTATE[1:0], TSTATE[1:0] bits are not affected by Initialization Mode

Read: anytime

Write: anytime when out of Initialization Mode

WUPIE — Wake-up Interrupt Enable

1 = A wake-up event causes a wake-up interrupt request.

0 = No interrupt request is generated from this event.

NOTE: *The CPU has to make sure that the Wake-up interrupt register and the WUPIE register (see [MSCAN Control 0 Register \(CANCTL0\)](#)) is enabled, if the recovery mechanism from STOP or WAIT is required.*

CSCIE — CAN Status Change Interrupt Enable

1 = A CAN Status Change event causes an error interrupt request.

0 = No interrupt request is generated from this event.

RSTATE1, RSTATE0— Receiver Status Change Enable

These RSTAT enable bits control the sensitivity level in which receiver state changes are causing CSCIF interrupts. Independent of the chosen sensitivity level the RSTAT flags still indicate the actual receiver state and are only updated if no CSCIF interrupt is pending.

11 = generate CSCIF interrupt on all state changes

10 = generate CSCIF interrupt only if the receiver enters or leaves 'RxErr' or 'BusOff'¹ state. Discard other receiver state changes for generating CSCIF interrupt.

01 = generate CSCIF interrupt only if the receiver enters or leaves 'BusOff' state. Discard other receiver state changes for generating CSCIF interrupt.

00 = do not generate any CSCIF interrupt caused by receiver state changes.

1. BusOff state is only defined by the CAN standard for transmitters. Because the only possible state change for the transmitter from BusOff to TxOK also forces the receiver to skip its current state to RxOK, the coding of the RXSTAT[1:0] flags define an additional BusOff state for the receiver (see [MSCAN Receiver Flag Register \(CANRFLG\)](#))

TSTATE1, TSTATE0 — Transmitter Status Change Enable

These TSTAT enable bits control the sensitivity level in which transmitter state changes are causing CSCIF interrupts. Independent of the chosen sensitivity level the TSTAT flags still indicate the actual transmitter state and are only updated if no CSCIF interrupt is pending.

- 11 = generate CSCIF interrupt on all state changes
- 10 = generate CSCIF interrupt only if the transmitter enters or leaves 'TxErr' or 'BusOff' state. Discard other transmitter state changes for generating CSCIF interrupt.
- 01 = generate CSCIF interrupt only if the transmitter enters or leaves 'BusOff' state. Discard other transmitter state changes for generating CSCIF interrupt.
- 00 = do not generate any CSCIF interrupt caused by transmitter state changes.

OVRIE — Overrun Interrupt Enable

- 1 = An overrun event causes an error interrupt request.
- 0 = No interrupt request is generated from this event.

RXFIE — Receiver Full Interrupt Enable

- 1 = A receive buffer full (successful message reception) event causes a receiver interrupt request.
- 0 = No interrupt request is generated from this event.

*MSCAN
Transmitter Flag
Register
(CANTFLG)*

The Transmit Buffer Empty flags each have an associated interrupt enable bit in the CANTIER register.

Address Offset: \$0006

	Bit 7	6	5	4	3	2	1	Bit 0
Read:	0	0	0	0	0	TXE2	TXE1	TXE0
Write:								
Reset:	0	0	0	0	0	1	1	1

= Unimplemented

NOTE: *The CANTFLG register is held in the reset state when the Initialization Mode is active (INITRQ=1 and INITAK=1). This register is writable again as soon as the Initialization Mode is left (INITRQ=0 and INITAK=0).*

Read: anytime

Write: anytime for TXEx flags when not in Initialization Mode; write of '1' clears flag, write of '0' ignored

TXE2–TXE0 —Transmitter Buffer Empty

This flag indicates that the associated transmit message buffer is empty, and thus not scheduled for transmission. The CPU must clear the flag after a message is set up in the transmit buffer and is due for transmission. The MSCAN sets the flag after the message is sent successfully. The flag is also set by the MSCAN when the transmission request is successfully aborted due to a pending abort request (see [MSCAN Transmitter Message Abort Control \(CANTARQ\)](#)). If not masked, a Transmit interrupt is pending while this flag is set.

Clearing a TXEx flag also clears the corresponding ABTAKx (see [MSCAN Transmitter Message Abort Control \(CANTAACK\)](#)). When a TXEx flag is set, the corresponding ABTRQx bit is cleared (see [MSCAN Transmitter Message Abort Control \(CANTARQ\)](#)).

When Listen-Mode is active (see [MSCAN Control 1 Register \(CANCTL1\)](#)) the TXEx flags cannot be cleared and no transmission is started.

1 = The associated message buffer is empty (not scheduled).

0 = The associated message buffer is full (loaded with a message due for transmission).

WARNING: *To ensure data integrity, do not write to the transmit buffer registers while the associated TXE flag is cleared.*

MSCAN

MSCAN
Transmitter
Interrupt Enable
Register (CANTIER)

This register contains the interrupt enable bits for the Transmit Buffer Empty interrupt flags.

Address Offset: \$0007

	Bit 7	6	5	4	3	2	1	Bit 0
Read:	0	0	0	0	0	TXEIE2	TXEIE1	TXEIE0
Write:								
Reset:	0	0	0	0	0	0	0	0

= Unimplemented

NOTE: *The CANTCR register is held in the reset state when the Initialization Mode is active (INITRQ=1 and INITAK=1). This register is writable again as soon as the Initialization Mode is left (INITRQ=0 and INITAK=0).*

Read: anytime

Write: anytime when not in Initialization Mode

TXEIE2–TXEIE0 — Transmitter Empty Interrupt Enable

1 = A transmitter empty (transmit buffer available for transmission) event causes a transmitter empty interrupt request.

0 = No interrupt request is generated from this event.

MSCAN
Transmitter
Message Abort
Control
(CANTARQ)

The CANTARQ register provides for abort request of queued messages as described below.

Address Offset: \$0008

	Bit 7	6	5	4	3	2	1	Bit 0
Read:	0	0	0	0	0	ABTRQ2	ABTRQ1	ABTRQ0
Write:								
Reset:	0	0	0	0	0	0	0	0

= Unimplemented

NOTE: The CANTARQ register is held in the reset state when the Initialization Mode is active (INITRQ=1 and INITAK=1). This register is writable again as soon as the Initialization Mode is left (INITRQ=0 and INITAK=0).

Read: anytime

Write: anytime when not in Initialization Mode

ABTRQ2–ABTRQ0 — Abort Request

The CPU sets the ABTRQx bit to request that a scheduled message buffer (TXEx=0) be aborted. The MSCAN grants the request if the message has not already started transmission, or if the transmission is not successful (lost arbitration or error). When a message is aborted, the associated TXE (see [MSCAN Transmitter Flag Register \(CANTFLG\)](#)) and Abort Acknowledge flags (ABTAK, see [MSCAN Transmitter Message Abort Control \(CANTAACK\)](#)) are set and a transmit interrupt occurs if enabled. The CPU cannot reset ABTRQx. ABTRQx is reset whenever the associated TXE flag is set.

1 = Abort request pending.

0 = No abort request.

MSCAN

MSCAN
Transmitter
Message Abort
Control
(CANTAACK)

The CANTAACK register indicates the successful abort of a queued message, if requested by the appropriate bits in the CANTARQ register

Address Offset: \$0009

	Bit 7	6	5	4	3	2	1	Bit 0
Read:	0	0	0	0	0	ABTAK2	ABTAK1	ABTAK0
Write:								
Reset:	0	0	0	0	0	0	0	0

 = Unimplemented

NOTE: The CANTAACK register is held in the reset state when the Initialization Mode is active (INITRQ=1 and INITAK=1).

Read: anytime

Write: unimplemented for ABTAKx flags;

ABTAK2–ABTAK0 — Abort Acknowledge

This flag acknowledges that a message was aborted due to a pending abort request from the CPU. After a particular message buffer is flagged empty, this flag can be used by the application software to identify whether the message was aborted successfully or was sent anyway. The ABTAKx flag is cleared whenever the corresponding TXE flag is cleared.

1 = The message was aborted.

0 = The message was not aborted.

MSCAN Transmit Buffer Selection (CANTBSEL)

The CANTBSEL register allows the selection of the actual transmit message buffer, which will be then accessible in the CANTXFG register space (see [Programmer's Model of Control Registers](#)).

Address Offset: \$000A

	Bit 7	6	5	4	3	2	1	Bit 0
Read:	0	0	0	0	0	TX2	TX1	TX0
Write:								
Reset:	0	0	0	0	0	0	0	0

= Unimplemented

NOTE: *The CANTBSEL register is held in the reset state when the Initialization Mode is active (INITRQ=1 and INITAK=1). This register is writable again as soon as the Initialization Mode is left (INITRQ=0 and INITAK=0).*

Read: find the lowest ordered bit set to '1', all other bits will be read as '0'
Write: anytime when not in Initialization Mode

Tx2–TX0 — Transmit Buffer Select

The lowest numbered bit places the respective transmit buffer in the CANTXFG register space (e.g. TX1=1 and TX0=1 selects transmit buffer TX0, TX1=1 and TX0=0 selects transmit buffer TX1)

1 = The associated message Buffer is selected, if lowest numbered bit.

0 = The associated message buffer is deselected

NOTE: *The following gives a short programming example of the usage of the CANTBSEL register:*

The application software wants to get the next available transmit buffer. It reads the CANTFLG register and writes this value back into the CANTBSEL register. In this example Tx buffers TX1 and TX2 are available. The value read from CANTFLG is therefore 8'b0000_0110. When writing this value back to CANTBSEL the Tx buffer TX1 is selected in the CANTXFG because the lowest numbered bit set to '1' is at bit position 1. Reading back this value out of CANTBSEL results in 8'b0000_0010, because only the lowest numbered bit position set to '1' is presented. This mechanism eases the application software the selection of the next available Tx buffer.

```

LDAA CANTFLG      ; value read is 8'b0000_0110
STAA CANTBSEL     ; value written is 8'b0000_0110
LDAA CANTBSEL     ; value read is 8'b0000_0010
.                 ;
.                 ; Fill TxBuffer
.                 ;
LDAA CANTBSEL     ; Read actual TxBuffer selection
STAA CANTFLG     ; Transmit selected TxBuffer
    
```

NOTE: If all transmit message buffers are deselected no accesses are allowed to the CANTXFG registers.

MSCAN Identifier Acceptance Control Register (CANIDAC)

The CANIDAC register provides for identifier acceptance control as described below.

Address Offset: \$000B

	Bit 7	6	5	4	3	2	1	Bit 0
Read:	0	0	IDAM1	IDAM0	0	IDHIT2	IDHIT1	IDHIT0
Write:								
Reset:	0	0	0	0	0	0	0	0

= Unimplemented

Read: anytime

Write: anytime in Initialization Mode (INITRQ=1 and INITAK=1), except bits IDHITx which are unimplemented

IDAM1–IDAM0 — Identifier Acceptance Mode

The CPU sets these flags to define the identifier acceptance filter organization (see [Identifier Acceptance Filter](#)). [Table 91](#) summarizes the different settings. In Filter Closed mode, no message is accepted such that the foreground buffer is never reloaded.

Table 91 Identifier Acceptance Mode Settings

IDAM1	IDAM0	Identifier Acceptance Mode
0	0	Two 32 bit Acceptance Filters
0	1	Four 16 bit Acceptance Filters
1	0	Eight 8 bit Acceptance Filters
1	1	Filter Closed

IDHIT2–IDHIT0 — Identifier Acceptance Hit Indicator

The MSCAN sets these flags to indicate an identifier acceptance hit (see [Identifier Acceptance Filter](#)). [Table 92](#) summarizes the different settings.

Table 92 Identifier Acceptance Hit Indication

IDHIT2	IDHIT1	IDHIT0	Identifier Acceptance Hit
0	0	0	Filter 0 Hit
0	0	1	Filter 1 Hit
0	1	0	Filter 2 Hit
0	1	1	Filter 3 Hit
1	0	0	Filter 4 Hit
1	0	1	Filter 5 Hit
1	1	0	Filter 6 Hit
1	1	1	Filter 7 Hit

The IDHITx indicators are always related to the message in the foreground buffer (RxFG). When a message gets shifted into the foreground buffer of the receiver FIFO the indicators are updated as well.

Reserved Registers These registers are reserved for factory testing of the MSCAN module and are not available in normal modes.

Address Offset: \$000C–\$000D

Bit 7 6 5 4 3 2 1 Bit 0

MSCAN

Read:	0	0	0	0	0	0	0	0
Write:								
Reset:	0	0	0	0	0	0	0	0

= Unimplemented

Read: always read \$00 in normal modes
 Write: unimplemented in normal modes

WARNING: *Writing to these registers when in special modes can alter the MSCAN functionality.*

MSCAN Receive Error Counter Register (CANRXERR)

This register reflects the status of the MSCAN receive error counter.

Address Offset: \$000E

	Bit 7	6	5	4	3	2	1	Bit 0
Read:	RXERR7	RXERR6	RXERR5	RXERR4	RXERR3	RXERR2	RXERR1	RXERR0
Write:								
Reset:	0	0	0	0	0	0	0	0

= Unimplemented

Read: only when in Sleep Mode (SLPRQ=1 and SLPK=1) or Initialization Mode (INITRQ=1 and INITAK=1)
 Write: unimplemented

WARNING: *Reading this register when in any other mode other than sleep or initialization, may return an incorrect value.*

Writing to this register when in special modes can alter the MSCAN functionality.

MSCAN Transmit
Error Counter
Register
(CANTXERR)

This register reflects the status of the MSCAN transmit error counter.

Address Offset: \$000F

	Bit 7	6	5	4	3	2	1	Bit 0
Read:	TXERR7	TXERR6	TXERR5	TXERR4	TXERR3	TXERR2	TXERR1	TXERR0
Write:								
Reset:	0	0	0	0	0	0	0	0

 = Unimplemented

Read: only when in Sleep Mode (SLPRQ=1 and SLPAK=1) or Initialization Mode (INITRQ=1 and INITAK=1)

Write: unimplemented

WARNING: *Reading this register when in any other mode other than sleep or initialization, may return an incorrect value.*

Writing to this register when in special modes can alter the MSCAN functionality.

MSCAN Identifier
Acceptance
Registers
(CANIDAR0–7)

On reception, each message is written into the background receive buffer. The CPU is only signalled to read the message if it passes the criteria in the identifier acceptance and identifier mask registers (accepted); otherwise, the message is overwritten by the next message (dropped).

The acceptance registers of the MSCAN are applied on the IDR0 to IDR3 registers (see [Identifier Registers \(IDR0–3\)](#)) of incoming messages in a bit by bit manner (see [Identifier Acceptance Filter](#)).

For extended identifiers, all four acceptance and mask registers are applied. For standard identifiers, only the first two (CANIDAR0/1, CANIDMR0/1) are applied.

MSCAN

Bit 7 6 5 4 3 2 1 Bit 0
 Address Offset: \$0010 CANIDAR0

Read:	AC7	AC6	AC5	AC4	AC3	AC2	AC1	AC0
Write:								
Reset:	0	0	0	0	0	0	0	0

Address Offset: \$0011 CANIDAR1

Read:	AC7	AC6	AC5	AC4	AC3	AC2	AC1	AC0
Write:								
Reset:	0	0	0	0	0	0	0	0

Address Offset: \$0012 CANIDAR2

Read:	AC7	AC6	AC5	AC4	AC3	AC2	AC1	AC0
Write:								
Reset:	0	0	0	0	0	0	0	0

Address Offset: \$0013 CANIDAR3

Read:	AC7	AC6	AC5	AC4	AC3	AC2	AC1	AC0
Write:								
Reset:	0	0	0	0	0	0	0	0

Bit 7 6 5 4 3 2 1 Bit 0
 Address Offset: \$0018 CANIDAR4

Read:	AC7	AC6	AC5	AC4	AC3	AC2	AC1	AC0
Write:								
Reset:	0	0	0	0	0	0	0	0

Address Offset: \$0019 CANIDAR5

Read:	AC7	AC6	AC5	AC4	AC3	AC2	AC1	AC0
Write:								
Reset:	0	0	0	0	0	0	0	0

Address Offset: \$001A CANIDAR6

Read:	AC7	AC6	AC5	AC4	AC3	AC2	AC1	AC0
Write:								
Reset:	0	0	0	0	0	0	0	0

Address Offset: \$001B CANIDAR7

Read:	AC7	AC6	AC5	AC4	AC3	AC2	AC1	AC0
Write:								
Reset:	0	0	0	0	0	0	0	0

Read: anytime

Write: anytime in Initialization Mode (INITRQ=1 and INITAK=1)

AC7–AC0 — Acceptance Code Bits

AC7–AC0 comprise a user defined sequence of bits with which the corresponding bits of the related identifier register (IDRn) of the receive message buffer are compared. The result of this comparison is then masked with the corresponding identifier mask register.

*MSCAN Identifier
Mask Registers
(CANIDMR0–7)*

The identifier mask register specifies which of the corresponding bits in the identifier acceptance register are relevant for acceptance filtering. To receive standard identifiers in 32 bit filter mode, it is required to program the last three bits (AM2–AM0) in the mask registers CANIDMR1 and CANIDMR5 to ‘don’t care’. To receive standard identifiers in 16 bit filter mode, it is required to program the last three bits (AM2–AM0) in the mask registers CANIDMR1, CANIDMR3, CANIDMR5 and CANIDMR7 to ‘don’t care’.

MSCAN

	Bit 7	6	5	4	3	2	1	Bit 0
Address Offset: \$0014								CANIDMR0
Read:	AM7	AM6	AM5	AM4	AM3	AM2	AM1	AM0
Write:								
Reset:	0	0	0	0	0	0	0	0

Address Offset: \$0015								CANIDMR1
Read:	AM7	AM6	AM5	AM4	AM3	AM2	AM1	AM0
Write:								
Reset:	0	0	0	0	0	0	0	0

Address Offset: \$0016								CANIDMR2
Read:	AM7	AM6	AM5	AM4	AM3	AM2	AM1	AM0
Write:								
Reset:	0	0	0	0	0	0	0	0

Address Offset: \$0017								CANIDMR3
Read:	AM7	AM6	AM5	AM4	AM3	AM2	AM1	AM0
Write:								
Reset:	0	0	0	0	0	0	0	0

	Bit 7	6	5	4	3	2	1	Bit 0
Address Offset: \$001C								CANIDMR4
Read:	AM7	AM6	AM5	AM4	AM3	AM2	AM1	AM0
Write:								
Reset:	0	0	0	0	0	0	0	0

Address Offset: \$001D								CANIDMR5
Read:	AM7	AM6	AM5	AM4	AM3	AM2	AM1	AM0
Write:								
Reset:	0	0	0	0	0	0	0	0

Address Offset: \$001E								CANIDMR6
Read:	AM7	AM6	AM5	AM4	AM3	AM2	AM1	AM0
Write:								
Reset:	0	0	0	0	0	0	0	0

Address Offset: \$001F								CANIDMR7
Read:	AM7	AM6	AM5	AM4	AM3	AM2	AM1	AM0
Write:								
Reset:	0	0	0	0	0	0	0	0

Read: anytime

Write: anytime in Initialization Mode (INITRQ=1 and INITAK=1)

AM7–AM0 — Acceptance Mask Bits

If a particular bit in this register is cleared, this indicates that the corresponding bit in the identifier acceptance register must be the same as its identifier bit before a match is detected. The message is accepted if all such bits match. If a bit is set, it indicates that the state of the corresponding bit in the identifier acceptance register does not affect whether or not the message is accepted.

1 = Ignore corresponding acceptance code register bit.

0 = Match corresponding acceptance code register and identifier bits.

**Programmer's
Model of Message
Storage**

The following section details the organization of the receive and transmit message buffers and the associated control registers. For reasons of programmer interface simplification, the receive and transmit message buffers have the same outline. Each message buffer allocates 16 bytes in the memory map containing a 13 byte data structure. An additional Transmit Buffer Priority Register (TBPR) is defined for the transmit buffers. Within the last two bytes of this memory map the MSCAN stores a special 16-bit time stamp, which is sampled from an internal timer after successful transmission or reception of a message. This feature is only available for transmit and receiver buffers, if the TIME bit is set (see [MSCAN Control 0 Register \(CANCTL0\)](#)). The Time Stamp register is written by the MSCAN. The CPU can only read these registers.

Addr	Register Name
\$00x0	Identifier Register 0
\$00x1	Identifier Register 1
\$00x2	Identifier Register 2
\$00x3	Identifier Register 3
\$00x4	Data Segment Register 0
\$00x5	Data Segment Register 1
\$00x6	Data Segment Register 2
\$00x7	Data Segment Register 3
\$00x8	Data Segment Register 4
\$00x9	Data Segment Register 5
\$00xA	Data Segment Register 6
\$00xB	Data Segment Register 7
\$00xC	Data Length Register
\$00xD	Transmit Buffer Priority Register ⁽¹⁾
\$00xE	Time Stamp Register (High Byte) ⁽²⁾
\$00xF	Time Stamp Register (High Byte) ⁽³⁾

Figure 102 Message Buffer Organization

1. Not Applicable for Receive Buffers
2. Read-Only for CPU
3. Read-Only for CPU

Figure 103 shows the common 13 byte data structure of receive and transmit buffers for extended identifiers. The mapping of standard identifiers into the IDR registers is shown in Figure 104. All bits of the receive and transmit buffers are 'x' out of reset because of RAM based implementation¹.

1. Exception: The Transmit Priority Registers are '0' out of reset

Register name		Bit 7	6	5	4	3	2	1	Bit 0	ADDR
IDR0	Read:	ID28	ID27	ID26	ID25	ID24	ID23	ID22	ID21	\$00x0
	Write:									
IDR1	Read:	ID20	ID19	ID18	SRR (=1)	IDE (=1)	ID17	ID16	ID15	\$00x1
	Write:									
IDR2	Read:	ID14	ID13	ID12	ID11	ID10	ID9	ID8	ID7	\$00x2
	Write:									
IDR3	Read:	ID6	ID5	ID4	ID3	ID2	ID1	ID0	RTR	\$00x3
	Write:									
DSR0	Read:	DB7	DB6	DB5	DB4	DB3	DB2	DB1	DB0	\$00x4
	Write:									
DSR1	Read:	DB7	DB6	DB5	DB4	DB3	DB2	DB1	DB0	\$00x5
	Write:									
DSR2	Read:	DB7	DB6	DB5	DB4	DB3	DB2	DB1	DB0	\$00x6
	Write:									
DSR3	Read:	DB7	DB6	DB5	DB4	DB3	DB2	DB1	DB0	\$00x7
	Write:									
DSR4	Read:	DB7	DB6	DB5	DB4	DB3	DB2	DB1	DB0	\$00x8
	Write:									
DSR5	Read:	DB7	DB6	DB5	DB4	DB3	DB2	DB1	DB0	\$00x9
	Write:									
DSR6	Read:	DB7	DB6	DB5	DB4	DB3	DB2	DB1	DB0	\$00xA
	Write:									
DSR7	Read:	DB7	DB6	DB5	DB4	DB3	DB2	DB1	DB0	\$00xB
	Write:									
DLR	Read:					DLC3	DLC2	DLC1	DLC0	\$00xC
	Write:									

= Unused

Figure 103 Receive / Transmit Message Buffer Extended Identifier

Read: anytime for transmit buffers; only when RXF flag is set for receive buffers (see [MSCAN Receiver Flag Register \(CANRFLG\)](#)).

Write: anytime for transmit buffers when TXEx flag is set (see [MSCAN Transmitter Flag Register \(CANTFLG\)](#)) and the corresponding transmit buffer is selected in CANTBSEL (see [MSCAN Transmit Buffer Selection \(CANTBSEL\)](#)); unimplemented for receive buffers

Reset: \$xx because of RAM based implementation

Register name		Bit 7	6	5	4	3	2	1	Bit 0	ADDR
IDR0	Read:	ID10	ID9	ID8	ID7	ID6	ID5	ID4	ID3	\$00x0
	Write:									
IDR1	Read:	ID2	ID1	ID0	RTR	IDE (=0)				\$00x1
	Write:									
IDR2	Read:									\$00x2
	Write:									
IDR3	Read:									\$00x3
	Write:									

= Unused

Figure 104 Standard Identifier Mapping

Identifier Registers (IDR0–3)

The identifier registers for an extended format identifier consist of a total of 32 bits; ID28–ID0, SRR, IDE, and RTR bits. The identifier registers for a standard format identifier consist of a total of 13 bits; ID10–ID0, RTR, and IDE bits.

ID28–ID0 — Extended format identifier

The identifiers consist of 29 bits (ID28–ID0) for the extended format. ID28 is the most significant bit and is transmitted first on the bus during the arbitration procedure. The priority of an identifier is defined to be highest for the smallest binary number.

ID10–ID0 — Standard format identifier

The identifiers consist of 11 bits (ID10–ID0) for the standard format. ID10 is the most significant bit and is transmitted first on the bus during the arbitration procedure. The priority of an identifier is defined to be highest for the smallest binary number.

SRR — Substitute Remote Request

This fixed recessive bit is used only in extended format. It must be set to 1 by the user for transmission buffers and is stored as received on the CAN bus for receive buffers.

IDE — ID Extended

This flag indicates whether the extended or standard identifier format is applied in this buffer. In the case of a receive buffer, the flag is set as received and indicates to the CPU how to process the buffer identifier registers. In the case of a transmit buffer, the flag indicates to the MSCAN what type of identifier to send.

1 = Extended format (29 bit)

0 = Standard format (11 bit)

RTR — Remote Transmission Request

This flag reflects the status of the Remote Transmission Request bit in the CAN frame. In the case of a receive buffer, it indicates the status of the received frame and supports the transmission of an answering frame in software. In the case of a transmit buffer, this flag defines the setting of the RTR bit to be sent.

1 = Remote frame

0 = Data frame

*Data Segment
Registers (DSR0–7)*

The eight data segment registers, each with bits DB7–DB0, contain the data to be transmitted or received. The number of bytes to be transmitted or received is determined by the data length code in the corresponding DLR register.

DB7–DB0 — Data Bits 7–0
*Data Length
Register (DLR)*

This register keeps the data length field of the CAN frame.

DLC3–DLC0 — Data Length Code bits

The data length code contains the number of bytes (data byte count) of the respective message. During the transmission of a remote frame, the data length code is transmitted as programmed while the

number of transmitted data bytes is always 0. The data byte count ranges from 0 to 8 for a data frame. Table 93 shows the effect of setting the DLC bits.

Table 93 Data length codes

Data length code				Data byte count
DLC3	DLC2	DLC1	DLC0	
0	0	0	0	0
0	0	0	1	1
0	0	1	0	2
0	0	1	1	3
0	1	0	0	4
0	1	0	1	5
0	1	1	0	6
0	1	1	1	7
1	0	0	0	8

Transmit Buffer Priority Register (TBPR)

This register defines the local priority of the associated message buffer. The local priority is used for the internal prioritization process of the MSCAN and is defined to be highest for the smallest binary number. The MSCAN implements the following internal prioritization mechanisms:

- All transmission buffers with a cleared TXEx flag participate in the prioritization immediately before the SOF (Start of Frame) is sent.
- The transmission buffer with the lowest local priority field wins the prioritization.
- In cases of more than one buffer having the same lowest priority, the message buffer with the lower index number wins.

Address Offset: \$xxxF

	Bit 7	6	5	4	3	2	1	Bit 0
Read:	PRI07	PRI06	PRI05	PRI04	PRI03	PRI02	PRI01	PRI00
Write:								
Reset:	0	0	0	0	0	0	0	0

Read: anytime
Write: anytime

*Time Stamp
Register (TSRH,
TSRL)*

If the TIME bit is enabled, the MSCAN will write a special time stamp to the respective registers in the active transmit or receive buffer as soon as a message has been acknowledged on the CAN bus (see [MSCAN Control 0 Register \(CANCTL0\)](#)). The time stamp is written on the bit sample point for the recessive bit of the ACK delimiter in the CAN frame. In case of a transmission, the CPU can only read the time stamp after the respective transmit buffer has been flagged empty.

The timer value, which is used for stamping, is taken from a free running internal CAN bit clock. A timer overrun is not indicated by the MSCAN. The timer is reset (all bits set to '0') during Initialization Mode. The CPU can only read the Time Stamp registers.

Address Offset: \$xxxE

	Bit 7	6	5	4	3	2	1	Bit 0
Read:	TSR15	TSR14	TSR13	TSR12	TSR11	TSR10	TSR9	TSR8
Write:								
Reset:	X	X	X	X	X	X	X	X

Address Offset: \$xxxF

	Bit 7	6	5	4	3	2	1	Bit 0
Read:	TSR7	TSR6	TSR5	TSR4	TSR3	TSR2	TSR1	TSR0
Write:								
Reset:	X	X	X	X	X	X	X	X

Read: anytime
Write: unimplemented

Modes of Operation

Normal Modes	The MSCAN module behaves as described within this specification in all normal modes.
Special Modes	The MSCAN module behaves as described within this specification in all special modes.
Emulation Modes	In all emulation modes, the MSCAN module behaves just like normal modes as described within this specification.
Listen-Only Mode	In an optional bus monitoring mode (Listen-Only), the CAN node is able to receive valid data frames and valid remote frames, but it sends only 'recessive' bits on the CAN bus. In addition it cannot start a transmission. If the MAC sublayer is required to send a 'dominant' bit (ACK bit, overload flag, active error flag), the bit is rerouted internally so that the MAC sublayer monitors this 'dominant bit, although the CAN bus may remain in recessive state externally.
Security Modes	The MSCAN module has no security features.

Low Power Options

If the MSCAN is disabled (CANE=0), the MSCAN clocks are stopped for power savings.

If the MSCAN is enabled (CANE=1), the MSCAN has two additional modes with reduced power consumption, compared to normal mode: Sleep and Power Down Mode. In Sleep Mode power consumption is reduced by stopping all clocks except those to access the registers from the CPU side. In Power Down Mode, all clocks are stopped and no power is consumed.

[Table 94](#) summarizes the combinations of MSCAN and CPU modes. A particular combination of modes is entered by the given settings on the CSWAI and SLPRQ/SLPAK bits.

For all modes, an MSCAN wake-up interrupt can only occur if the MSCAN is in Sleep Mode (SLPRQ=1 and SLPK=1), wake-up functionality is enabled (WUPE=1) and the wake-up interrupt is enabled (WUPIE=1).

Table 94 CPU vs. MSCAN Operating Modes

CPU Mode	MSCAN Mode			
	Normal	Power Down	Sleep	(CANE=0)
RUN	CSWAI = X ⁽¹⁾ SLPRQ = 0 SLPAK = 0		CSWAI = X SLPRQ = 1 SLPAK = 1	CSWAI = X SLPRQ = X SLPAK = X
WAIT		CSWAI = 1 SLPRQ = X SLPAK = X	CSWAI = 0 SLPRQ = 1 SLPAK = 1	CSWAI = X SLPRQ = X SLPAK = X
STOP	CSWAI = X SLPRQ = 0 SLPAK = 0	CSWAI = X SLPRQ = X SLPAK = X	CSWAI = X SLPRQ = 1 SLPAK = 1	CSWAI = X SLPRQ = X SLPAK = X

1. 'X' means don't care.

MSCAN

CPU Run Mode	As can be seen in Table 94 , only MSCAN Sleep Mode is available as low power option, when CPU is in run mode.
CPU Wait Mode	<p>The WAI instruction puts the MCU in a low power consumption stand-by mode. If the CSWAI bit is set, then additional power can be saved in Power Down Mode since the CPU clocks are stopped. After leaving this Power Down Mode the MSCAN restarts its internal controllers and enters Normal Mode again</p> <p>While the CPU is in Wait Mode, the MSCAN can be operated in Normal Mode and generate interrupts (registers can be accessed via background debug mode). The MSCAN can also operate in any of the low power modes depending on the values of the SLPRQ/SLPAK and CSWAI bits as seen in Table 94.</p>
Stop Mode	The STOP instruction puts the MCU in a low power consumption stand-by mode. In Stop mode, the MSCAN operates in Power Down mode regardless of the value of the SLPRQ/SLPAK and CSWAI bits (see CPU vs. MSCAN Operating Modes).
MSCAN Sleep Mode	<p>The CPU can request the MSCAN to enter this low power mode by asserting the SLPRQ bit in the CANCTL0 register. The time when the MSCAN enters Sleep Mode depends on a fixed synchronisation delay and its current activity:</p> <ul style="list-style-type: none"> • If it is transmitting, it continues to transmit until the entire message is transmitted and then goes into Sleep Mode. • If it is receiving, it waits for the end of this message and then goes into Sleep Mode. • If it is neither transmitting nor receiving, it immediately goes into Sleep Mode.

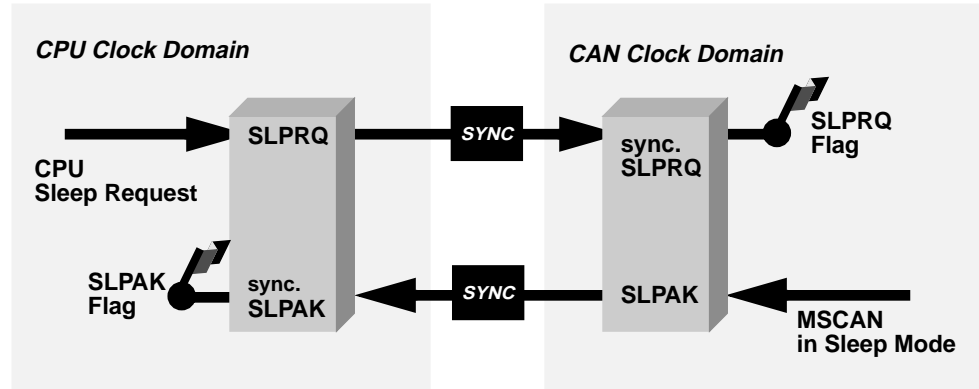

Figure 105 Sleep Request / Acknowledge Cycle

CAUTION: *The application software must avoid setting up a transmission (by clearing one or more TXEx flag(s)) and immediately request Sleep Mode (by setting SLPRQ). It depends on the exact sequence of operations whether the MSCAN starts transmitting or goes into Sleep Mode directly.*

If Sleep Mode is active, the SLPRQ and SLPK bits are set (see [Figure 105](#)). The application software must use SLPK as a handshake indication for the request (SLPRQ) to go into Sleep Mode.

When in Sleep Mode (SLPRQ=1 and SLPK=1), the MSCAN stops its internal clocks. However, clocks to allow register accesses from the CPU side still run. If the MSCAN is in bus-off state, it stops counting the 128*11 consecutive recessive bits due to the stopped clocks. The TxCAN pin remains in a recessive state. If RXF=1, the message can be read and RXF can be cleared. Shifting a new message into the foreground buffer of the receiver FIFO (RxFG) does not take place while in Sleep Mode. It is possible to access the transmit buffers and to clear the associated TXE flags. No message abort takes place while in sleep mode. If the WUPE bit in CANCLT0 is not asserted, the MSCAN will mask any activity it detects on CAN. The RxCAN pin is therefore held internally in a recessive state. This locks the MSCAN in Sleep Mode (see [Figure 106](#)).

The MSCAN is only able to leave Sleep Mode (wake-up) when

- bus activity occurs and WUPE=1 or
- the MCU clears the SLPRQ bit

NOTE: The MCU cannot clear the SLPRQ bit before Sleep Mode (SLPRQ=1 and SLPAK=1) is active.

After wake-up, the MSCAN waits for 11 consecutive recessive bits to synchronize to the bus. As a consequence, if the MSCAN is woken-up by a CAN frame, this frame is not received. The receive message buffers (RxFG and RxBG) contain messages if they were received before sleep mode was entered. All pending actions will be executed upon wakeup; copying of RxBG into RxFG, message aborts and message transmissions. If the MSCAN is still in bus-off state after sleep mode was left, it continues counting the 128*11 consecutive recessive bits.

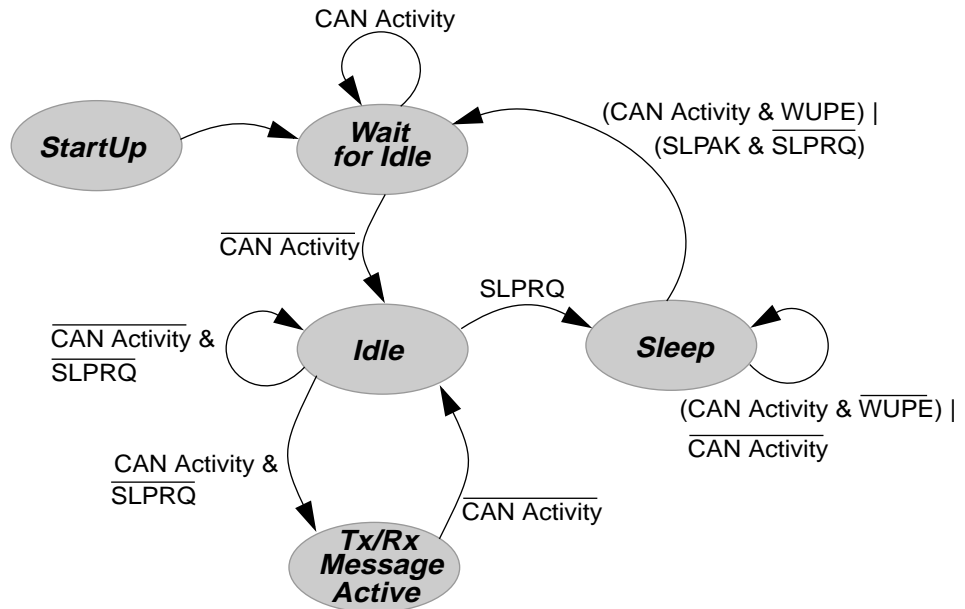

Figure 106 Simplified State Transitions for Entering/Leaving Sleep Mode

MSCAN Initialization Mode

In Initialization Mode, any ongoing transmission or reception is immediately aborted and synchronization to the bus is lost potentially causing CAN protocol violations. To protect the CAN bus system from fatal consequences of violations, the MSCAN immediately drives the TxCAN pin into a recessive state.

The user is responsible for ensuring that the MSCAN is not active when Initialization Mode is entered. The recommended procedure is to bring

the MSCAN into Sleep Mode ($SLPRQ=1$ and $SLPAK=1$) before setting the $INITRQ$ bit in the $CANCTL0$ register. Otherwise the abort of an ongoing message can cause an error condition and can have an impact on the other bus devices.

In Initialization Mode, the MSCAN is stopped. However, interface registers can still be accessed. This mode is used to reset the $CANTCTL0$, $CANRFLG$, $CANRIER$, $CANTFLG$, $CANTIER$, $CANTARQ$, $CANTAACK$, $CANTBSEL$ registers to their default values. In addition it enables the configuration of the $CANBTR0$, $CANBTR1$ bit timing registers, $CANIDAC$ and the $CANIDAR$, $CANIDMR$ message filters. See [MSCAN Control 0 Register \(\$CANCTL0\$ \)](#) for a detailed description of the Initialization Mode.

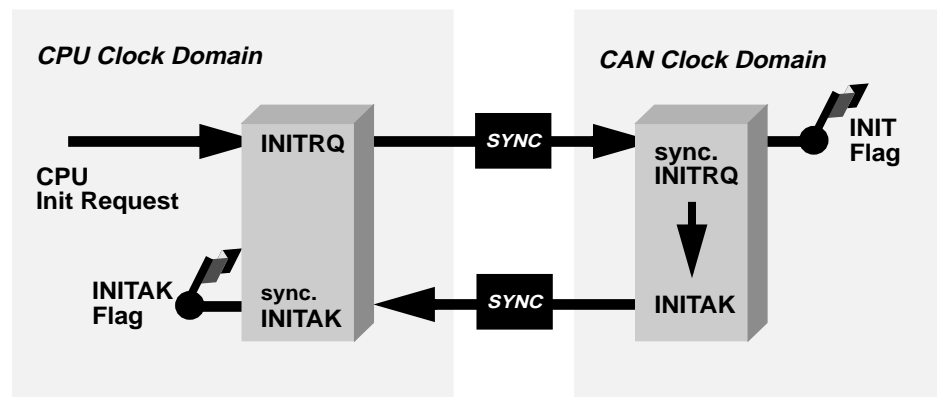

Figure 107 Initialization Request/Acknowledge Cycle

Due to independent clock domains within the MSCAN the $INITRQ$ has to be synchronized to all domains by using a special handshake mechanism. This handshake causes additional synchronisation delay (see [Initialization Request/Acknowledge Cycle](#)). If there is no message transfer ongoing on the CAN bus, the minimum delay will be two additional bus clocks and three additional CAN clocks. When all parts of the MSCAN are in Initialization Mode the $INITAK$ flag is set. The application software must use $INITAK$ as a handshake indication for the request ($INITRQ$) to go into Initialization Mode.

NOTE: *The MCU cannot clear the $INITRQ$ bit before Initialization Mode ($INITRQ=1$ and $INITAK=1$) is active.*

MSCAN
MSCAN Power Down Mode

The MSCAN is in Power Down Mode when [Table 94](#)

- the CPU is in Stop Mode or
- the CPU is in Wait Mode and the CSWAI bit is set.

When entering the Power Down Mode, the MSCAN immediately stops all ongoing transmissions and receptions, potentially causing CAN protocol violations. To protect the CAN bus system from fatal consequences of violations to the above rule, the MSCAN immediately drives the TxCAN pin into a recessive state.

CAUTION: *The user is responsible for ensuring that the MSCAN is not active when Power Down Mode is entered. The recommended procedure is to bring the MSCAN into Sleep Mode before the STOP or WAI instruction (if CSWAI is set) is executed. Otherwise the abort of an ongoing message can cause an error condition and can have an impact on the other bus devices.*

In Power Down Mode, all clocks are stopped and no registers can be accessed. If the MSCAN was not in Sleep Mode before Power Down Mode became active, the module would perform an internal recovery cycle after powering up. This causes some fixed delay before the module enters Run Mode again.

Programmable Wake-Up Function

The MSCAN can be programmed to wake-up the MSCAN as soon as bus activity is detected (see control bit WUPE in [MSCAN Control 0 Register \(CANCTL0\)](#)). The sensitivity to existing bus action can be modified by applying a low-pass filter function to the RxCAN input line while in Sleep Mode (see control bit WUPM in [MSCAN Control 1 Register \(CANCTL1\)](#)). This feature can be used to protect the MSCAN from wake-up due to short glitches on the CAN bus lines. Such glitches can result e.g. from electromagnetic interference within noisy environments.

Interrupt Operation

The MSCAN supports four interrupt vectors mapped onto eight different interrupt sources, any of which can be individually masked (for details see sections [MSCAN Receiver Flag Register \(CANRFLG\)](#) to [MSCAN Transmitter Interrupt Enable Register \(CANTIER\)](#)):

- *Transmit Interrupt:* At least one of the three transmit buffers is empty (not scheduled) and can be loaded to schedule a message for transmission. The TXEx flag of the empty message buffer is set.
- *Receive Interrupt:* A message is successfully received and shifted into the foreground buffer (RxFG) of the receiver FIFO. This interrupt is generated immediately after receiving the EOF symbol. The RXF flag is set. If there are multiple messages in the receiver FIFO, the RXF flag is set as soon as the next message is shifted to the foreground buffer.
- *Wake-Up Interrupt:* Activity on the CAN bus occurred during MSCAN internal Sleep Mode and WUPE (see [MSCAN Control 0 Register \(CANCTL0\)](#)) enabled.
- *Error Interrupt:* An overrun of the receiver FIFO, error or warning condition occurred. The [MSCAN Receiver Flag Register \(CANRFLG\)](#) indicates one of the following conditions:
 - *Overrun:* An overrun condition of the receiver FIFO as described in [Receive Structures](#) occurred.
 - *CAN Status Change:* The actual value of the Transmit and Receive Error Counters control the bus state of the MSCAN. As soon as the Error Counters skip into a critical range (Tx/Rx-Warning, Tx/Rx-Error, Bus-Off) the MSCAN flags out an error condition. The status change, which caused the error condition, is indicated within the TSTAT and RSTAT flags (see [Receive Structures](#) and [MSCAN Receiver Interrupt Enable Register \(CANRIER\)](#)).
 - *Bus Off:* The Transmit Error Counter has exceeded 255 and MSCAN has gone to Bus-Off state. This flag is redundant with respect to the Can Status Change Interrupt Flag (CSCIF) flag

MSCAN

Interrupt Acknowledge

Interrupts are directly associated with one or more status flags in either the [MSCAN Receiver Flag Register \(CANRFLG\)](#) or the [MSCAN Transmitter Flag Register \(CANTFLG\)](#). Interrupts are pending as long as one of the corresponding flags is set. The flags in the above registers must be reset within the interrupt handler to handshake the interrupt. The flags are reset by writing a '1' to the corresponding bit position. A flag cannot be cleared if the respective condition still prevails.

CAUTION: *It must be guaranteed that the CPU only clears the bit causing the current interrupt. For this reason, bit manipulation instructions (BSET) must not be used to clear interrupt flags. These instructions may cause accidental clearing of interrupt flags which are set after entering the current interrupt service routine.*

Interrupt Sources

The MSCAN supports four interrupt functions as shown in [Table 95](#).

NOTE: *The vector addresses and the relative interrupt priority are determined at the MCU level.*

Table 95 MSCAN Interrupt Sources

Interrupt Function	Interrupt Flag	Local Enable	Global (CCR) Mask
Wake-Up	WUPIF	WUPIE	I Bit
Error Interrupts	CSCIF	CSCIE	
	OVRIF	OVRIE	
Receive	RXF	RXFIE	
Transmit	TXE0	TXEIE0	
	TXE1	TXEIE1	
	TXE2	TXEIE2	

Recovery from STOP or WAIT

The MSCAN can recover from STOP or WAIT via the wake-up interrupt. This interrupt can only occur if the MSCAN is in sleep mode (SLPRQ=1 and SLPK=1), the wake-up option is enabled (WUPE=1) and the wake-up interrupt is enabled (WUPIE=1).

Analog to Digital Converter

Contents

Overview	555
Features	556
Block Diagram	557
Register Map	559
Functional Description	561
Register Descriptions	572
External Pin Descriptions	595
Reset Initialization	596
Modes of Operation	597
Sample Conversion	599
General Purpose Input Ports	602

Overview

This A/D converter is designed as a peripheral bus environment module for the MC9S12DP256 Modular Microcontroller Family. The A/D architecture is a successive approximation architecture that has been used for many years on microcontroller units (MCUs). It is a rugged and proven architecture capable of 10-bit accuracy when operated on-chip with a clocked MCU.

This module is designed to be upwards compatible with the 68HC11 standard 8-bit A/D converters. Many of the operating modes are defined based on the 68HC11 requirements. In addition, there are new operating modes that are unique to the HC12 design.

Features

- 8/10 Bit Resolution.
- 7 μ sec, 10-Bit Single Conversion Time.
- Sample Buffer Amplifier.
- Programmable Sample Time.
- Left/Right Justified, Signed/Unsigned Result Data.
- External Trigger Control.
- Conversion Completion Interrupt Generation.
- Analog Input Multiplexer for 8 Analog Input Channels.
- Analog/Digital Input Pin Multiplexing.
- 1 to 8 Conversion Sequence Lengths.
- Continuous Conversion Mode.
- Multiple Channel Scans.

Block Diagram

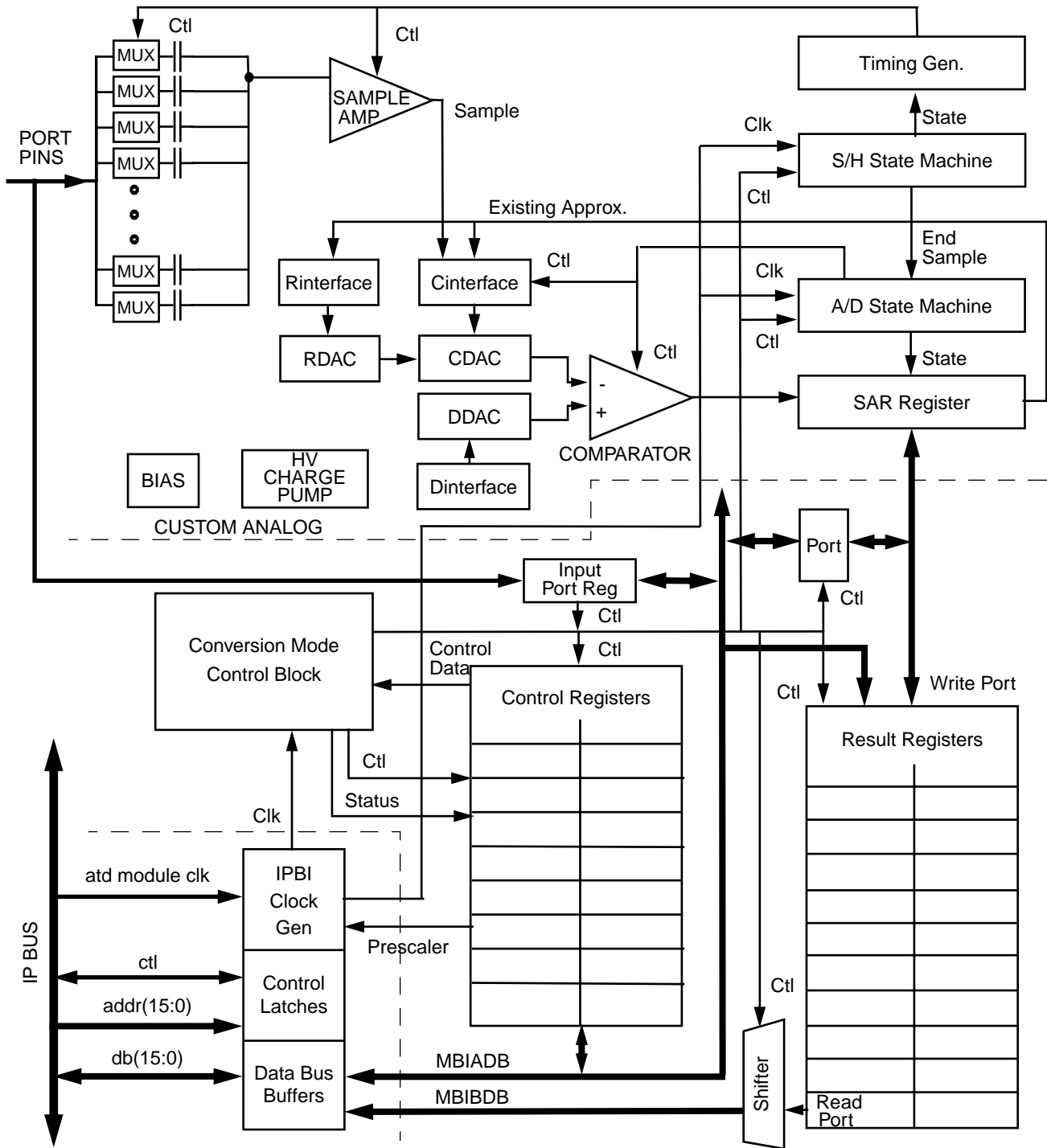

Figure 108 ATD Module Block Diagram

Analog to Digital Converter

Functional Block Diagram

The block diagram in [Figure 108](#) illustrates the functional structure of the A/D module. The functionality is divided into three submodules as denoted by the dashed lines on the figure. These are the IP Bus Interface, the Conversion Mode Control/Register File, and the Custom Analog.

The IP Bus Interface connects the module to the bus. The objective was to design an ATD module with a generic I/O requirements; this would connect to a particular bus with a specific bus interface. The bus interface contains a clock generation block which clocks the rest of the module. This groups the module's clocking requirements into one block.

The Conversion Mode Control/Register File defines the HC12 programmers environment for the ATD module. All of the control, status, test, and result registers are located in this submodule. The mechanics that control the various operating modes and scans for the module are implemented here.

The Custom Analog performs analog to digital conversions. It accepts signals from the conversion control machine and the sample machine. This sub-module contains all analog and digital electronics required to perform a single conversion.

A more complete description of each sub-module is provided in the Functional Description section of the specification.

Register Map

Add	Reg Name		Bit 7	6	5	4	3	2	1	Bit 0
\$00	ATDCTL0	Read:	0	0	0	0	0	0	0	0
		Write:								
\$01	ATDCTL1	Read:	0	0	0	0	0	0	0	0
		Write:								
\$02	ATDCTL2	Read:								
		Write:	ADPU	AFFC	AWAI	ETRIGLE	ETRIGP	ETRIGE	ASCIE	ASCIF
\$03	ATDCTL3	Read:	0							
		Write:		S8C	S4C	S2C	S1C	FIFO	FRZ1	FRZ0
\$04	ATDCTL4	Read:								
		Write:	SRES8	SMP1	SMP0	PRS4	PRS3	PRS2	PRS1	PRS0
\$05	ATDCTL5	Read:					0			
		Write:	DJM	DSGN	SCAN	MULT		CC	CB	CA
\$06	ATDSTAT0	Read:	SCF	0	ETORF	FIFOR	0	CC2	CC1	CC0
		Write:								
\$07	ATDSTAT1	Read:	CCF7	CCF6	CCF5	CCF4	CCF3	CCF2	CCF1	CCF0
		Write:								
\$08	ATDTEST0	Read:	SAR9	SAR8	SAR7	SAR6	SAR5	SAR4	SAR3	SAR2
		Write:								
\$09	ATDTEST1	Read:	SAR1	SAR0	0	0	0		0	
		Write:						RST		SC
\$0A	reserved0A	Read:	0	0	0	0	0	0	0	0
		Write:								
\$0B	reserved0B	Read:	0	0	0	0	0	0	0	0
		Write:								
\$0C	reserved0C	Read:	0	0	0	0	0	0	0	0
		Write:								
\$0D	ATDDIEN	Read:								
		Write:	Bit7	Bit6	Bit 5	Bit 4	Bit 3	Bit 2	Bit 1	Bit 0
\$0E	reserved0E	Read:	0	0	0	0	0	0	0	0
		Write:								
\$0F	PORTAD1	Read:	Bit7	Bit6	Bit5	Bit4	Bit3	Bit2	Bit1	Bit0
		Write:								
\$10	ATDDR0H	Read:	Bit15	Bit14	Bit13	Bit12	Bit11	Bit10	Bit9	Bit8
		Write:								
\$11	ATDDR0L	Read:	Bit7	Bit6	Bit5	Bit4	Bit3	Bit2	Bit1	Bit0
		Write:								
\$12	ATDDR1H	Read:	Bit15	Bit14	Bit13	Bit12	Bit11	Bit10	Bit9	Bit8
		Write:								

= Unimplemented or Reserved

Analog to Digital Converter

Add	Reg Name		Bit 7	6	5	4	3	2	1	Bit 0
\$13	ATDDR1L	Read:	Bit7	Bit6	Bit5	Bit4	Bit3	Bit2	Bit1	Bit0
		Write:								
\$14	ATDDR2H	Read:	Bit15	Bit14	Bit13	Bit12	Bit11	Bit10	Bit9	Bit8
		Write:								
\$15	ATDDR2L	Read:	Bit7	Bit6	Bit5	Bit4	Bit3	Bit2	Bit1	Bit0
		Write:								
\$16	ATDDR3H	Read:	Bit15	Bit14	Bit13	Bit12	Bit11	Bit10	Bit9	Bit8
		Write:								
\$17	ATDDR3L	Read:	Bit7	Bit6	Bit5	Bit4	Bit3	Bit2	Bit1	Bit0
		Write:								
\$18	ATDDR4H	Read:	Bit15	Bit14	Bit13	Bit12	Bit11	Bit10	Bit9	Bit8
		Write:								
\$19	ATDDR4L	Read:	Bit7	Bit6	Bit5	Bit4	Bit3	Bit2	Bit1	Bit0
		Write:								
\$1A	ATDDR5H	Read:	Bit15	Bit14	Bit13	Bit12	Bit11	Bit10	Bit9	Bit8
		Write:								
\$1B	ATDDR5L	Read:	Bit7	Bit6	Bit5	Bit4	Bit3	Bit2	Bit1	Bit0
		Write:								
\$1C	ATDDR6H	Read:	Bit15	Bit14	Bit13	Bit12	Bit11	Bit10	Bit9	Bit8
		Write:								
\$1D	ATDDR6L	Read:	Bit7	Bit6	Bit5	Bit4	Bit3	Bit2	Bit1	Bit0
		Write:								
\$1E	ATDDR7H	Read:	Bit15	Bit14	Bit13	Bit12	Bit11	Bit10	Bit9	Bit8
		Write:								
\$1F	ATDDR7L	Read:	Bit7	Bit6	Bit5	Bit4	Bit3	Bit2	Bit1	Bit0
		Write:								



= Unimplemented or Reserved

Functional Description

Please refer to the functional block diagram [Figure 108](#) in reference to the functional description of the ATD module

Custom Analog

Sample and Hold Submodule

The Sample and Hold (S/H) Machine accepts analog signals from the external world and stores them as capacitor charge on a storage node in the module. With the exception of the storage node, this sub-module contains all analog and digital electronics required to perform a single sample. The current sample process uses a stage approach. During the stage, the sample amplifier is used to quickly charge the storage node with a reflection of the sample capacitor potential. The final stage connects the input directly to the storage node to complete the sample for high accuracy.

This submodule accepts as input a begin_sample signal, a sample time code, a channel select code, a reset signal, a power down signal, two clock signals, and 8 analog lines. This submodule provides as output an end_sample signal and an analog sampled signal (during the sample period). For power, this submodule requires VDD, VDDA, VSS, and VSSA. Two bias lines are required from the bias generator.

When not sampling, the sample and hold submodule disables its own clocks at the input into this submodule. The analog electronics still draw their quiescent current. The power down (ADPU) bit must be set to disable both the digital clocks and the analog power consumption.

The input analog signals are unipolar. The signals must fall within the potential range of VSSA to VDDA (analog electronics supply potentials).

This sub-module is not required in order to perform the special conversions (i.e.: to convert V_{rl} , V_{rh} , and $(V_{rl}+V_{rh})/2$).

Analog Input Multiplexer

The analog input multiplexer selects one of the 8 external analog input channels to generate an analog sample. It can be expanded to 16 external analog input channels.

Analog to Digital Converter

The analog input multiplexer includes negative stress protection circuitry which prevents crosstalk between channels when the applied input potentials are within specification.

Sample Buffer Amplifier

The sample amplifier is used to buffer the input analog signal so that the storage node can be quickly charged to the sample potential.

Limitations

The current ATD module architecture allows for only one sample storage node which is located in the A/D machine. As a result, only one sample can be held at a time; this means the S/H machine and the A/D machine cannot run concurrently even though they are independent machines. The minimum conversion time is therefore dependent on the program selection of the sample time. The current minimum conversion time specification uses the minimum sample time.

No DC level correction, channel to channel gain adjust, or other data acquisition functions are currently performed on the input analog signals.

Analog-to-Digital Converter Submodule

The Analog-to-Digital (A/D) Machine performs analog to digital conversions. The resolution of the A/D converter is program selectable at either 8 or 10 bits. This machine uses a successive approximation A/D architecture. It functions by comparing the stored analog sample potential with a series of digitally generated analog potentials. By following a binary search algorithm, the converter locates the approximating potential that is nearest to the sampled potential.

This submodule contains all the necessary analog and digital electronics to perform a single analog to digital conversion. This module accepts as input a begin_sample signal, an end_sample signal, a 8/10 bit resolution select line, a special conversion select line, a two wire conversion type bus, a reset signal, a power down signal, a clock signal, an input analog signal, and two reference potentials. This submodule provides as output a 10-bit digital word and an end_convert signal as outputs. For power, this submodule requires VDD, VDDA, VSS, VSSA. and Vhv (the in-module generated high voltage potential). One bias line is required from the bias generator.

When not sampling, the analog-to-digital submodule disables its own clocks at the input into this submodule. The analog electronics still draws quiescent current. The power down (ADPU) bit must be set to disable both the digital clocks and the analog power consumption.

Note that only analog input signals within the potential range of V_{RL} to V_{RH} (A/D reference potentials) will result in a non-railed digital output codes.

This sub-module performs special test conversions internally without the aid of the sample submodule (i.e.: to convert V_{RL} , V_{RH} , and $(V_{RL}+V_{RH})/2$).

*Resistor and
Capacitor DAC
Arrays*

The A/D core is a 10 bit analog to digital converter implemented in a 0.25 micron CMOS process capable of being manufactured in numerous foundries without detrimental affects. It must also be capable of accepting 5 volts inputs without permanent damage while simultaneously operating at 5 volts. This can be rather challenging.

The heart of the converter consist of a combination of resistors and capacitors. In particular, a thermometer code 7 bit resistor string for the MSB and 3 bits of capacitors to determine the LSB. The chip presently operates with a single-ended signal but can be modified for a sign bit which would allow for negative signals.

The design is a 10 bit single ended design using a “pseudo” differential scheme. The first 7 MSB bits consist of a 1 of 128 resistor string. The remaining 3 LSB bits are binary weighted capacitor of value 8c, 4c, 2c, and 1c. The last C is an extra C which can be used for offset compensation of + 1/2 LSB.

Comparator

The comparator is a three stage comparator. The first two stages are capacitively coupled, differential comparator stages; these add a fixed gain to the comparison signal. The last stage is a clocked regenerative comparator stage; this stage drives the input comparison signal to the operating potential rails. The input offset voltage of the comparator is removed from the stored sample by zeroing the comparator before the sample process. The gain required by the comparator for 10-bit accuracy is greater than 60dB.

Analog to Digital Converter

<i>A/D State Machine and SAR (Successive Approximation Register)</i>	<p>The A/D state machine controls the conversion process in the A/D converter. The machine needs to know when a sample period is occurring since the sample storage node is located on the CDAC capacitor array. The machine works closely with the SAR to perform a binary search algorithm. The intermediate results in the SAR are used by the CDAC and RDAC interface circuits to determine which switches to set to generate the next approximation potential. At the end of the conversion process, the SAR contains the nearest approximation to the sampled signal given the resolution of the A/D converter.</p>
<i>Limitations</i>	<p>The specification minimum conversion time is set by the settling time of the digitally generated compare potentials. The settling time is limited by the RC time constant of the RDAC/CDAC arrays. Basically it takes 2 clocks to settle. So the time constant is approximately 1 μsec.</p>
Conversion Mode Control and Register File	<p>This section defines the programmer interface to the ATD module. The register file defines the address space used to access the module's controls, status, and data. The conversion mode control uses the control register settings to define the overall flow of the ATD module's operations.</p>
<i>Control/Status Registers and Control Section</i>	<p>There are eight control registers and three status registers associated with the ATD module. IP bus writes to ATDCTL4&5 registers initiate a new conversion sequence. If a conversion sequence is already running, this sequence will be aborted and a new sequence will be begun.</p> <p>The Mode Control communicates with the S/H machine and the A/D machine when necessary to collect samples and perform conversions. The Mode Control issues a "begin_sample" signal which for a normal conversion signals the S/H machine to begin collecting a sample and for the A/D machine to begin receiving a sample. At the end of the sample period, the S/H machine issues a end_sample signal which signals the A/D machine to begin the analog to digital conversion process. The conversion process is terminated when the A/D machine issues an end_convert signal back to the Mode Control unit. For special test mode conversions (V_{RL}, V_{RH}, $(V_{RL}+V_{RH})/2$), the sample machine is important because it generates an end_sample signal; the A/D machine uses the</p>

reference potentials to set the sampled signal level within itself without relying on the sample machine to deliver them.

Mode Control organizes the conversion sequences, specifies the input sample channel, implements the external trigger mode, and move digital output data from the SAR to the result registers. One important task is to control register file read/write timing to avoid conflicts between IP bus accesses and ATD module updates to the same register at the same time.

The result registers consists of two port latches. The SAR writes data into the register through one port; the module data bus reads data out of the registers through the other port.

*External Trigger
Input (ETRIG)*

The external trigger feature allows the user to synchronize ATD conversions to the external environment events rather than relying on software to signal the ATD module when ATD conversions are to take place. The input signal is programmable to be edge or level sensitive with polarity control. If level sensitivity is selected the **atd_etrig** input signal is treated like a trigger gate.

In edge trigger mode the **active edge** of the external trigger signal is used to signal the ATD module when to begin sampling the input.

A summary of the external trigger function is shown in [Table 96](#). This table gives a brief description of the different combinations of control bits and their affect on the external trigger function.

Table 96 External Trigger Control Bits

ETRIGLE	ETRIGP	ETRIGE	SCAN	Description
X	X	0	0	Ignores external trigger. Performs one conversion sequence and stops.
X	X	0	1	Ignores external trigger. Performs continuous conversion sequences.
0	0	1	X	Falling edge triggered. Performs one conversion sequence per trigger.
0	1	1	X	Rising edge triggered. Performs one conversion sequence per trigger.
1	0	1	X	Trigger active low. Performs continuous conversions while trigger is active.
1	1	1	X	Trigger active high. Performs continuous conversions while trigger is active.

During a conversion, if additional active edges are detected, an overrun error condition exists. If one or more edges are detected during a conversion sequence, the overrun flag is set; ETORF bit in ATDSTAT0.

In level trigger mode, the active level of the external trigger signal is used to gate the ATD module. The ATD conversion is performed immediately after the sample period is completed. At the end of conversion sequence, if the active level is still present the sample and conversion process is performed again.

In either level or edge triggered modes, the first conversion begins when the trigger is received. In both cases, the maximum latency time for the ATD module is 1 ATD module clock cycle plus any skew or delay introduced by the trigger circuitry.

NOTE: *Note that if the ETRIG input shares an analog channel input any ATD conversions performed on samples from the external trigger channel will be erroneous while the external trigger mode is enabled.*

The external trigger input is enabled by the ETRIGE, ETRIGP, ETRIGLE control bits in ATDCTL2. When ETRIGE is first enabled, a conversion sequence is initiated by an external event transitioning the ETRIG pin. Once ETRIGE is enabled, conversions cannot be started by a write to ATDCTL5, but rather must be triggered externally.

External trigger mode operates with the other operating modes to produce a variety of external triggered modes. For example, by selecting a conversion sequence length of one, the ATD module can be made to perform a single conversion per active edge of the external trigger. Since, interrupts can be generated by the end of the sequence, this mode will signal the MCU after single external events. By selecting a larger conversion sequence length, an entire sequence of conversions can be performed on one external trigger event.

If the level mode is active and the external trigger both de-asserts and re-asserts itself during a conversion sequence, this does not constitute an overrun. Therefore, the flag is not set. If the trigger is left asserted in level mode while a sequence is completing, another sequence will be triggered immediately. If the level sensitive mode is selected and ETRIG input is held active, subsequent conversion sequences occur after the sequence complete flag is set.

**General Purpose
Digital Input Port
Operation**

The input channel pins can be multiplexed between analog and digital data. As analog inputs, they are multiplexed and sampled to supply signals to the A/D converter. As digital inputs, they supply external input data that can be accessed through the digital port registers.

The analog/digital multiplex operation is performed in the input pads. The input pad is always connected to the analog inputs of the ATD module. The input pad signal is buffered before the data is bussed to the digital port registers. The buffer is a schmitt trigger nand so that the buffer can be turned off; this is important so that the buffer does not draw excess current when analog potentials are presented at its input. This is particularly important when some of the inputs are being used as digital inputs and some as analog inputs. To minimize excess current draw, the buffer is enabled only if the respective ATDDIEN bit is set. If this bit is not set a digital read will always return a “1”. Analog signals present on

the input pins at the digital sampling time that don't meet the V_{IL} or V_{IH} specification will return unknown digital values. A read of the PORTAD1 may affect the accuracy of an in progress sample period but will not affect an in progress A/D conversion.

There is a digital, 8-bit, input-only port associated with the ATD. It is accessed through the 8-bit Port Data Register (PORTAD1). The number of bits utilized in the port register depends on the number of analog channels implemented with the 8 channel ATD module.

Clock Prescale Function

To keep the ATD module's conversion clock within the specified frequency range, a clock prescale function is available. This function divides the ATD module clock by a program selectable binary constant in order to generate the ATD module's conversion clock. The ATD conversion clock is used to clock both the sample machine and the A/D machine.

Another important benefit of the prescaled clock feature is that it allows the user control over the sample period. Note that if the prescale function is used this way, the conversion time is also affected.

The prescale feature is based on a 5 bit modulus counter and will divide the clock by an integer value between 1 and 32. The final clock frequency is obtained with a further division by 2. Therefore, the highest possible ATD conversion clock frequency is one half of the ATD module clock frequency, but cannot be faster than the maximum ATD operating frequency as defined in the electrical specification. The maximum speed of ATD conversion frequency is 2 MHz. [Table 102](#) lists the prescale value for various setting of the control register bits. [Figure 109](#) is a block diagram of the clock prescale logic.

The ATD conversion clock and the ATD module clock have a direct phase relationship. However, the ATD module operates as if it is effectively asynchronous to IP bus cycles.

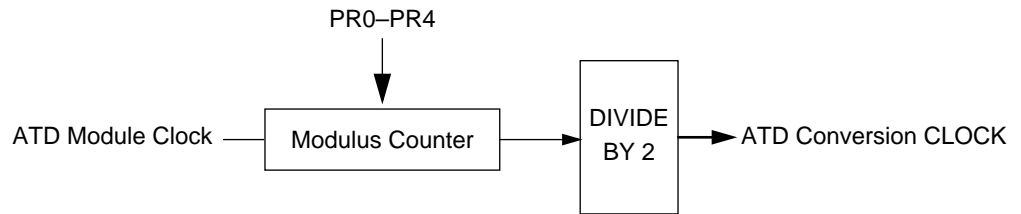

Figure 109 ATD Clock Select/Prescale.

Power Down Mode

The ATD module can be powered down under program control. This is done by turning the clock signals off to the digital electronics of the module and eliminating the quiescent current draw of the analog electronics.

Program power down control is implemented in one of three ways. First, by using the ADPU bit in control register ATDCTL2, the module can be powered down when this bit is reset to zero. Second, when the module bus **ipg_stop** is activated, the module will power down for the duration of the **ipg_stop** signal. Third, if the module stop_in_wait enable bit is set and the **ipg_wait** line is activated, the module will power down for the duration of the **ipg_wait** signal.

Note that the reset default for the ADPU bit is zero. Therefore, when this module is reset, it is reset into the power down state. (The exception is the test mode power down which resets the module into idle mode.)

Once the command to power down has been received, the ATD module aborts any conversion sequence in progress and enters lower power mode. When the module is powered up again, the module must be given time to stabilize the bias settings in the analog electronics before conversions can be performed. Note that powering up the module does not reset the module since the register file is not initialized.

Note that in power down mode, the control and result registers are still accessible.

Analog to Digital Converter

**Background
Debug (ATD
FREEZE) Mode**

When debugging an application, it is useful to have the ATD pause when a breakpoint is encountered. To accommodate this, there are two FREEZE bits in the ATDCTL3 register used to select one of three responses: First, the ATD module may ignore the background signal. Second, it may respond to the freeze request by finishing the current conversion and freezing before starting the next sample period. Third, it may respond by immediately freezing.

The FREEZE state is implemented by stopping the ATD clock when the module background signal is asserted. Control and timing logic is static allowing the register contents and timing position to be remembered indefinitely. The analog electronics remains powered up; however, leakage onto the storage node and comparator reference capacitors may compromise the accuracy of a frozen conversion depending on the length of the freeze period. When the background signal is negated, clock activity resumes. The bus interface remains active to allow module access to the ATD register block during the frozen period.

Module Reset

The ATD module is reset on two different events. First, if the IP bus master reset signal is activated, the ATD module is reset. Second, if the RST bit in the ATDTEST register is activated, the ATD module is reset. The single difference between the two events is that the RST bit event does not reset the ADPU bit to its reset state value - i.e.: the module is not reset into a powered down state.

The ATD module reset function places the module back into an initialized state. If the module is performing a conversion sequence, both the current conversion and the sequence are terminated. The conversion complete flags are cleared and any pending interrupts are cancelled. Note that the control, test, and status registers are initialized on reset; the initialized register state is defined in the register description section of this specification.

The ATD module is powered down on reset (except for the RST bit reset event). This occurs as a function of the register file initialization; the reset definition of the ADPU bit (power down bit) is zero or powered down. Note the RST bit reset event does not reset the ADPU bit to its reset value so the module will be returned to an idle state following this reset triggering event.

Note that when the module powers up via the **ipg_wait** signal that the ATD is *not* reset; ATD operation proceeds as it was prior to entering the wait. Freezing the module does not cause it to be reset. If a freeze mode is entered and defines that the current conversion be terminated, then this is done and the module will be idle after exiting the freeze state, but the module is not initialized. Powering the module up (using the ADPU bit) does not cause the module to reset since the register file is not initialized. Finally, writing to control register ATDCTL4/5 does *not* cause the module to be reset; the current conversion and sequence will be terminated and new ones started; the conversion complete flags and pending interrupts will be cleared. However, this is a restart operation rather than a reset operation because the register file is not initialized.

Freescale Semiconductor, Inc.

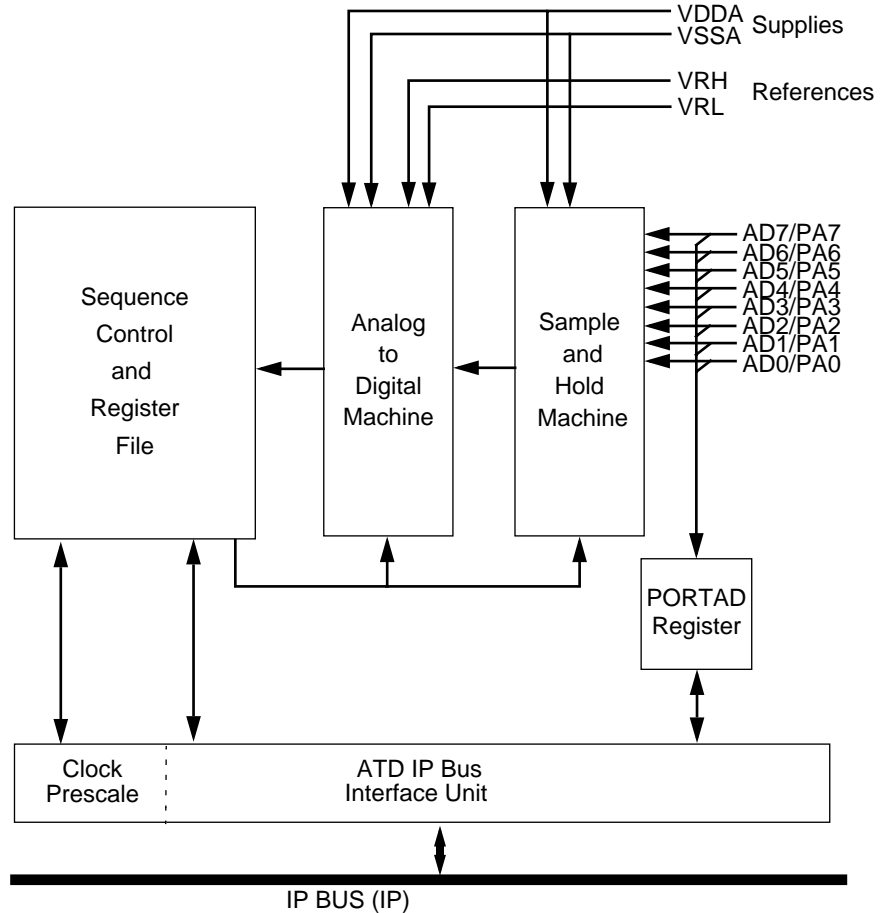

Figure 110 ATD Block Interface Diagram

Register Descriptions

**Register
Arrangement and
IP Address
Mapping**

The base address of the module is hardware programmable. The ATD register map is fixed and begins at the module's base address.

[Figure 111](#) summarizes the ATD module's address space. The following subsections describe the bit-level arrangement and functionality of each register.

The ATD module is clocked by the ATD module clock. The module signals valid output data to the MCU via interrupts or conversion complete flags. Therefore, it does not need a synchronizing signal to inform the CPU of conversion complete.

The module has two internal buses with which to move control, status, and result data between internal registers and the IP bus. The IP bus controls activity on these internal buses based on bus requests to the ATD module. The ATD module moves result data into the dual ported result registers through a separate dedicated result bus to avoid collisions with IP bus accesses. Special attention is paid so that IP bus accesses to the ATD register file do not conflict with module updates to the same register at the same time.

When control bits are written by the IP bus, they update the control register immediately. If an A/D conversion is in progress, the results are not guaranteed until the next A/D conversion cycle begins.

		Offset from Base Address	Register Name
ATDCTL0	ATDCTL1	\$00, \$01	reserved
ATDCTL2	ATDCTL3	\$02, \$03	ATD Control Register 2 & 3
ATDCTL4	ATDCTL5	\$04, \$05	ATD Control Register 4 & 5
ATDSTAT0	ATDSTAT1	\$06, \$07	ATD Status Register 0 & 1
ATDTEST0	ATDTEST1	\$08, \$09	ATD Test Register 0 & 1
-	-	\$0A, \$0B, \$0C	reserved
-	ATDDIEN	\$0D	ATD Input Enable Mask Register
-	-	\$0E	reserved
-	PORTAD1	\$0F	PORTAD Register
ATDDR0H	ATDDR0L	\$10, \$11	ATD Result Register 0 (ATDDR0)
ATDDR1H	ATDDR1L	\$12, \$13	ATD Result Register 1 (ATDDR1)
ATDDR2H	ATDDR2L	\$14, \$15	ATD Result Register 2 (ATDDR2)
ATDDR3H	ATDDR3L	\$16, \$17	ATD Result Register 3 (ATDDR3)
ATDDR4H	ATDDR4L	\$18, \$19	ATD Result Register 4 (ATDDR4)
ATDDR5H	ATDDR5L	\$1A, \$1B	ATD Result Register 5 (ATDDR5)
ATDDR6H	ATDDR6L	\$1C, \$1D	ATD Result Register 6 (ATDDR6)
ATDDR7H	ATDDR7L	\$1E, \$1F	ATD Result Register 7 (ATDDR7)

Figure 111 Summary of ATD Module Register File

Analog to Digital Converter

ATD Control Register 2 & 3 (ATDCTL2, ATDCTL3)

The ATD control register 2 & 3 are used to select the power up mode, fast flag clear mode, wait mode, 1 to 8 channel mode, interrupt control, and freeze control. Writes to these registers will *not* abort current conversion sequence *nor* start a new sequence.

Address Offset: \$0002–\$0003

	Bit 15	14	13	12	11	10	9	Bit 8
	ADPU	AFFC	AWAI	ETRIGLE	ETRIGP	ETRIGE	ASCIE	ASCIF
Reset:	0	0	0	0	0	0	0	0
	Bit 7	6	5	4	3	2	1	Bit 0
	0	S8C	S4C	S2C	S1C	FIFO	FRZ1	FRZ0
Reset:	0	0	1	0	0	0	0	0

READ: any time
 WRITE: any time
 (except for Bit 8 – ASCIF, READ: any time, WRITE: not allowed)

Bit Positions: 7

This bit is unused and always reads back as zero

ADPU — ATD Disable / Power Down

- 1 = Normal ATD functionality.
- 0 = Disable and power down the ATD.

This bit provides program on/off control over the ATD module allowing reduced MCU power consumption when the ATD is not being used. When reset to zero, the ADPU bit aborts any conversion sequence in progress. Because the analog electronics is turned off when powered down, the ATD requires a recovery time period when ADPU bit is enabled.

AFFC — ATD Fast Conversion Complete Flag Clear

- 1 = All ATD conversion complete flags use fast clear mode.
- 0 = All ATD conversion complete flags clear normally.

Normal conversion complete clearing means that the status register must be read after the conversion complete flag has been set before that flag can be reset. After the status register read, a read to the associated result register causes its conversion complete flag in the status register to be cleared. The SCF flag is cleared when a new

conversion sequence is begun by writing to control register ATDCTL4/5. In application where the ATD module is being polled to determine if an ATD conversion is complete, this feature provides a convenient way of clearing the status register conversion complete flag.

In applications where ATD interrupts are used to signal conversion completion, the precondition of reading the status register can be eliminated – hence the fast conversion complete flag clear mode. In this mode, any access to a result register will cause its associated conversion complete flag in the status register to be cleared. The SCF flag is cleared after the first (any) result register is read.

AWAI — ATD Wait Mode

- 1 = Enable ATD wait function during MCU Wait mode.
- 0 = Disable ATD wait function.

The wait function allows the MCU to selectively halt and power down the ATD module. If the AWAI bit is set and the MCU asserts the IP bus **wait_mode**, then the ATD module immediately halts operation and powers down. When the **wait_mode** is released, the ATD module powers up and continues operation. The module is *not* reset; the register file is *not* initialized; the conversion sequence is *not* restarted. If the AWAI is reset (zero), then the ATD module ignores the **wait_mode** line.

ETRIGLE — External Trigger Level/Edge control

- This bit sets the mode of the incoming external trigger signal
- 1 = Level mode – active level gates ATD operation
 - 0 = Edge mode – active edge mode

ETRIGP — External Trigger Polarity

- This bit controls the polarity of the external trigger signal
- 1 = Active high level or rising edge active
 - 0 = Active low level or falling edge active

ETRIGE — External Trigger Mode enable

- 1 = Enable external trigger mode
- 0 = Disable external trigger mode.

External trigger mode allows the user to synchronize sample and ATD conversions processes with external events.

External Gated Continuous-Scan Mode is defined when the SCAN and ETRIGLE bits are set. It allows the user to synchronize the conversion process with external events and control the number of conversion performed in sequence. The ETRIG active level initiates a conversion and at the end of the conversion if the ETRIGE bit is active another sample is initiated.

Note that the conversion results for the external trigger channel have no meaning while external trigger mode is enabled.

Table 97 Left Justified, Signed and Unsigned ATD Output Codes

Input Signal Vrl = 0 Volts Vrh = 5.12 Volts	Signed 8-Bit Codes	Unsigned 8-Bit Codes	Signed 10-Bit Codes	Unsigned 10-Bit Codes
5.120 Volts	7F	FF	7FC0	FFC0
5.100	7F	FF	7F00	FF00
5.080	7E	FE	7E00	FE00
2.580	01	81	0100	8100
2.560	00	80	0000	8000
2.540	FF	7F	FF00	7F00
0.020	81	01	8100	0100
0.000	80	00	8000	0000

ASCIE — ATD Sequence Complete Interrupt Enable

1 = Enables ATD interrupt on Sequence Complete.

0 = Disables ATD interrupt.

The sequence complete interrupt function signals the MCU when a conversion sequence is complete. At this time, the result registers contain the result data generated by the conversion sequence. If this interrupt function is disabled, then the conversion complete flags must be polled to determine when a conversion or a conversion sequence is complete. Note that reset clears pending interrupts.

ASCIF — ATD Sequence Complete Interrupt Flag

1 = ATD sequence complete interrupt occurred.

0 = No ATD sequence complete interrupt occurred.

The sequence complete interrupt flag. This flag is not cleared until the interrupt is serviced (by reading the result data in such a way that the conversion complete flag is cleared), a new conversion sequence is initiated, or the module is reset. This bit is not writable in any mode.

S8C/S4C/S2C/S1C — Conversion Sequence Length

S8C/S4C/S2C/S1C represents a binary value which is the length of the conversion sequence. [Table 98](#) lists the coding combinations implemented.

Table 98 Conversion Sequence Length Coding.

S8C	S4C	S2C	S1C	Number of Conversions per Sequence
0	0	0	0	8
0	0	0	1	1
0	0	1	0	2
0	0	1	1	3
0	1	0	0	4
0	1	0	1	5
0	1	1	0	6
0	1	1	1	7
1	X	X	X	8

At reset, S4C is set to 1, so that the sequence length is 4 after reset. This is to maintain software continuity to HC12 family. In other HC12 designs, the reset state for the SxCs are 0, which defaults to a sequence length of four.

Note that the maximum number of conversions in a sequence depends on how many channels are available in the ATD module. This module is an 8 channel module. The number of result registers is also 8. Each A/D conversion result is stored in one result register. Therefore the maximum number of conversions in a sequence is limited to the number of result registers in the module. In this case, the maximum number of conversions is 8; therefore, at 0000, the number of conversions is 8.

The result register assignments made to a conversion sequence follow a few simple rules. Normally, the first result is placed in the first register; the second result is placed in the second register, and so on. [Table 99](#) presents the result register assignments for the various conversion lengths that are normally made. If FIFO mode is used, the result register assignments differ. The results are placed in consecutive registers between conversion sequences; the result register mapping wraps around when the end of the register file is reached.

Table 99 Result Register Assignment for Different Conversion Sequences.

Number of Conversions per Sequence	Result Register Assignment
1	ATDDR0
2	ATDDR0 through ATDDR1
3	ATDDR0 through ATDDR2
4	ATDDR0 through ATDDR3
5	ATDDR0 through ATDDR4
6	ATDDR0 through ATDDR5
7	ATDDR0 through ATDDR6
8	ATDDR0 through ATDDR7

FIFO — Result Register FIFO Mode

- 1 = Result registers **do not** map to the conversion sequence.
- 0 = Result registers maps to the conversion sequence.

In normal operation, the A/D conversion results map into the result registers based on the conversion sequence; the result of the first conversion appears in the first result register, the second result in the second result register, and so on. In FIFO mode the result register counter is not reset at the beginning or ending of a conversion sequence; conversion results are placed in consecutive result registers between sequences. The result register counter wraps around when it reaches the end of the result register file. The

conversion counter value in ATDSTAT0 can be used to determine where in the result register file, the next conversion result will be placed.

The results register counter is initialized to zero on three events: on reset, the beginning of a normal (non-FIFO) conversion sequence, and the end of a normal (non-FIFO) conversion sequence. Therefore, the reset bit in register ATDTEST1 can be toggled to zero the result register counter; any sequence allowed to complete normally will zero the result register counter; a new sequence (non-FIFO) initiated with a write to ATDCTL4/5 followed by a write to ATDCTL3 to set the FIFO bit will start a FIFO sequence with the result register initialized.

Finally, which result registers hold valid data can be tracked using the conversion complete flags. Fast flag clear mode may or may not be useful in a particular application to track valid data.

FRZ1, FRZ0 — Background Debug Freeze Enable

Background debug freeze function allows the ATD module to pause when a breakpoint is encountered. A breakpoint is signaled when the IP bus asserts the ipg_freeze signal. [Table 100](#) shows how FRZ1 and FRZ0 determine the ATD's response to a breakpoint. When the ipg_freeze signal is released, the ATD module continues operating as it was before the breakpoint occurred. The module is *not* reset; the register file is *not* initialized; the conversion sequence is *not* restarted (i.e.: current sequence is aborted and a new one started).

Table 100 Module Freeze Response

FRZ1	FRZ0	ATD RESPONSE
0	0	Ignore the background signal
0	1	Reserved
1	0	Finish current conversion, then freeze
1	1	Freeze Immediately

Analog to Digital Converter

ATD Control Register 4 (ATDCTL4)

ATD control register 4 is used to select the ATD conversion clock frequency (based on the ATD module clock), select the length of the third phase of the sample period, and set the resolution of the A/D conversion (i.e.: 8-bits or 10-bits). All writes to this register have an immediate effect. If a conversion is in progress, the entire conversion sequence is aborted.

Address Offset: \$0004

	Bit 15	14	13	12	11	10	9	Bit 8
	SRES8	SMP1	SMP0	PRS4	PRS3	PRS2	PRS1	PRS0
Reset:	0	0	0	0	0	1	0	1

SRES8 — A/D Resolution Select
 1 = 8-bit resolution selected.
 0 = 10-bit resolution selected.

This bit determines the resolution of the A/D converter: 8-bits or 10-bits. The A/D converter has the accuracy of a 10-bit converter. However, if low resolution is required, the conversion can be speeded up by selecting 8-bit resolution.

SMP0, SMP1 — Sample Time Select

These two bits select the length of the third phase of the sample period in ATD conversion clock cycles. Note that the ATD conversion clock period is itself a function of the prescaler value (bits PRS0-4). The sample period consists of three phases. The first phase is two ATD conversion clock cycles long and samples the signal on the channel's sample capacitor. The second phase is four clock cycles and its purpose is to quickly transfer the sample onto the A/D machine's storage node in preparation for conversion. The third phase occurs after the buffered sample and transfer and attaches the

external analog signal directly to the storage node for final charging and high accuracy. [Table 101](#) lists the lengths available for the third sample phase.

Table 101 Sample Time Select

SMP1	SMP0	Final Sample Time
0	0	2 A/D clock periods
0	1	4 A/D clock periods
1	0	8 A/D clock periods
1	1	16 A/D clock periods

PRS0, PRS1, PRS2, PRS3, PRS4 — ATD Clock Prescaler

The binary prescaler value (0 to 31) plus one (1 to 32) becomes the divide-by factor for a modulus counter used to prescale the ATD module clock frequency. The resulting scaled clock is further divided by 2 before the ATD conversion clock is generated. This clock is used to drive the S/H and A/D machines.

Note that the maximum ATD conversion clock frequency is half of the ATD module clock. The default prescaler value is one which results in a default ATD conversion clock frequency that is quarter of the ATD module clock. [Table 102](#) illustrates the divide-by operation and the appropriate range of ATD module clock frequencies.

Table 102 Clock Prescaler Values

Prescale Value	Total Divisor Value	Max ATD Module Clock ⁽¹⁾	Min ATD Module Clock ⁽²⁾
00000	divide by 2	4 MHz	1 MHz
00001	divide by 4	8 MHz	2 MHz
00010	divide by 6	12 MHz	3 MHz
00011	divide by 8	16 MHz	4 MHz
00100	divide by 10	20 MHz	5 MHz
00101	divide by 12	24 MHz	6 MHz
00110	divide by 14	28 MHz	7 MHz
00111	divide by 16	32 MHz	8 MHz
01000	divide by 18	36 MHz	9 MHz
01001	divide by 20	40 MHz	10 MHz
01010	divide by 22	44 MHz	11 MHz
01011	divide by 24	48 MHz	12 MHz
01100	divide by 26	52 MHz	13 MHz
01101	divide by 28	56 MHz	14 MHz
01110	divide by 30	60 MHz	15 MHz
01111	divide by 32	64 MHz	16 MHz
10000	divide by 34	68 MHz	17 MHz
10001	divide by 36	72 MHz	18 MHz
10010	divide by 38	76 MHz	19 MHz
10011	divide by 40	80 MHz	20 MHz
10100	divide by 42	84 MHz	21 MHz
10101	divide by 44	88 MHz	22 MHz
10110	divide by 46	92 MHz	23 MHz
10111	divide by 48	96 MHz	24 MHz
11000	divide by 50	100 MHz	25 MHz
11001	divide by 52	104 MHz	26 MHz
11010	divide by 54	108 MHz	27 MHz
11011	divide by 56	112 MHz	28 MHz
11100	divide by 58	116 MHz	29 MHz
11101	divide by 60	120 MHz	30 MHz
11110	divide by 62	124 MHz	31 MHz
11111	divide by 64	128 MHz	32 MHz

1. Maximum ATD conversion clock frequency is 2MHz. The max. ATD module clock frequency is computed from the max. ATD clock frequency times the indicated prescaler setting.

2. Minimum ATD clock frequency is 500KHz. The min. ATD module clock frequency is computed from the min. ATD clock frequency times the indicated prescaler setting.

ATD Control Register 5 (ATDCTL5)

ATD control register 5 determines the type of conversion sequence and the analog input channels sampled. All writes to this register have an immediate effect. If a conversion is in progress, the entire conversion

sequence is aborted. A write to this register (or ATDCTL4) initiates a new conversion sequence.

Address Offset: \$0005

	Bit 7	6	5	4	3	2	1	Bit 0
	DJM	DSGN	SCAN	MULT	0	CC	CB	CA
Reset:	0	0	0	0	0	0	0	0

DJM — Result Register Data Justification Mode

- 1 = Right justified mode.
- 0 = Left justified mode.

This bit determines how the result register data maps onto the IP data bus bits. The mapping depends on resolution setting of the A/D converter.

For 10-bit resolution, left justified mode maps a result register into data bus bits 6 through 15; bit 15 is the MSB. In right justified mode, the result registers maps onto data bus bits 0 through 9; bit 9 is the MSB.

For 8-bit resolution, left justified mode maps a result into the high byte (bits 8 though 15; bit 15 is the MSB). Right justified maps a result into the low byte (bits 0 through 7; bit 7 is the MSB).

The IP bus signal **sz8** forces all data transfers to be 8-bits wide. This does not affect the justification of the data. Only the byte addressed is retrieved.

DSGN — Signed/Unsigned Result Data Mode

- 1 = Signed result register data select.
- 0 = Unsigned result register data select.

The signed/unsigned result data control bit determined is the result data read from the result registers is signed data or unsigned data. Signed data is represented as 2's complement data.

Note that signed data is not available for right justified data. Therefore, sign extension hardware is not required.

[Table 103](#) summarizes the result data formats available and how they are set up using the control bits.

Table 104 illustrates the difference between the signed and unsigned, left justified output codes for an input signal range between 0 and 5.1 Volts.

Table 103 Result Data Formats Available.

SRES8	DJM	DSGN	Result Data Formats Description and Bus Bit Mapping
1	0	0	8-bit/left justified/unsigned - bits 8-15
1	0	1	8-bit/ left justified/signed - bits 8-15
1	1	X	8-bit/right justified/unsigned - bits 0-7
0	0	0	10-bit/left justified/unsigned - bits 6-15
0	0	1	10-bit/left justified/signed - bits 6-15
0	1	X	10-bit/right justified/unsigned - bits 0-9

Table 104 Left Justified, Signed and Unsigned ATD Output Codes.

Input Signal Vrl = 0 Volts Vrh = 5.12 Volts	Signed 8-Bit Codes	Unsigned 8-Bit Codes	Signed 10-Bit Codes	Unsigned 10-Bit Codes
5.120 Volts	7F	FF	7FC0	FFC0
5.100	7F	FF	7F00	FF00
5.080	7E	FE	7E00	FE00
2.580	01	81	0100	8100
2.560	00	80	0000	8000
2.540	FF	7F	FF00	7F00
0.020	81	01	8100	0100
0.000	80	00	8000	0000

SCAN — Continuous Conversion Sequence Mode

1 = Perform conversion sequences continuously.

0 = Perform a conversion sequence and return to idle mode.

The scan mode bit controls whether or not conversion sequences are performed continuously or not. If this control bit is 0, a write to control register 4 or 5 will initiate a conversion sequence; the conversion sequence will be executed; sequence complete flag (SCF) will be set, and the module will return to idle mode. In this mode, the module remains powered up but no conversions are performed; the module waits for the next conversion sequence to be initiated.

If this control bit is 1, a single conversion sequence initiation will result in continuously executed conversion sequence. When a conversion sequence completes, the sequence complete flag (SCF) is set and a new sequence is immediately begun. The conversion mode characteristics of each sequence are identical. If a new conversion mode is required, the existing continuous sequence must be interrupted, the control registers modified, and a new conversion sequence initiated.

MULT — Multi-Channel Sample Mode

1 = Sample across many channels.

0 = Sample only the specified channel.

When MULT is 0, the ATD sequence controller samples only from the specified analog input channel for an entire conversion sequence. The analog channel is selected by channel selection code (control bits CC/CB/CA located in ATDCTL5). When MULT is 1, the ATD sequence controller samples across channels. The number of channels sampled is determined by the sequence length value (S8C, S1C control bits). The first analog channel examined is determined by channel selection code (CC, CB, CA control bits); subsequent channels sampled in the sequence are determined by incrementing the channel selection code.

CC, CB, CA — Analog Input Channel Select Code

These bits select the analog input channel(s) whose signals are sampled and converted to digital codes. [Table 105](#) lists the coding used to select the various analog input channels. In the case of single channel scans (MULT=0), this selection code specified the channel examined. In the case of multi-channel scans (MULT=1), this selection code represents the first channel to be examined in the conversion sequence. Subsequent channels are determined by incrementing channel selection code; selection codes that reach the maximum value wrap around to the minimum value.

Note that for special conversion mode, bits CC/CB/CA have a different function. Instead of specifying the analog input channel, they identify which special channel conversion is to take place. See [Table 106](#) for a list of the special conversions that are available through these bits.

Table 105 Analog Input Channel Select Coding

CC	CB	CA	Analog Input Channel
0	0	0	AD0
0	0	1	AD1
0	1	0	AD2
0	1	1	AD3
1	0	0	AD4
1	0	1	AD5
1	1	0	AD6
1	1	1	AD7

A/D Status Register (ATDSTAT)

The ATD Status registers contain the conversion complete flags and the conversion sequence counter. The status registers are normally read-only. In special (test) mode, the SCF bit and the CCF bits may also be written.

Address Offset: \$0006–\$0007

	Bit 15	14	13	12	11	10	9	Bit 8
	SCF	0	ETORF	FIFOR	0	CC2	CC1	CC0
Reset:	0	0	0	0	0	0	0	0
	Bit 7	6	5	4	3	2	1	Bit 0
	CCF7	CCF6	CCF5	CCF4	CCF3	CCF2	CCF1	CCF0
Reset:	0	0	0	0	0	0	0	0

SCF — Sequence Complete Flag

This flag is set upon completion of a conversion sequence. If conversion sequences are continuously performed (SCAN=1), the flag is set after each one is completed. How this flag is cleared depends on the setting of the fast flag clear bit (AFFC in ATDCTL2). When AFFC=0, SCF is cleared when a new conversion sequence is initiated (write to register ATDCTL4/5). When AFFC=1, SCF is cleared after reading the first (any) result register.

ETORF — External Trigger Overrun Flag

While in edge trigger mode, if additional active edges are detected while a conversion sequence is in process the overrun flag is set.

- 1 = External trigger overrun error has occurred
- 0 = No External trigger overrun error has occurred

FIFOR — FIFO Over Run Flag.

- 1 = An over run condition exists
- 0 = No over run has occurred

This bit indicates that a result register has been written to before its associated conversion complete flag (CCF) has been cleared. This flag is most useful when using the FIFO mode because the flag potentially indicates that result registers are out of sync with the input channels. However, it is also practical for non-FIFO modes, and indicates that a result register has been over written before it has been read (i.e. the old data has been lost).

CC2/CC1/CC0 — Conversion Counter

This 3-bit value represents the contents of the result register counter; the result register counter points to the result register that will receive the result of the current conversion. If not in FIFO mode, the register counter is initialized to zero when a new conversion sequence is begun. If in FIFO mode, the register counter is not initialized. The result register count wraps around when its maximum value is reached.

CCF7 through CCF0 — Conversion Complete Flags

A conversion complete flag is set at the end of each conversion in a conversion sequence. The flags are associated with the conversion position in a sequence (and also the result register number).

Therefore, CCF0 is set when the first conversion in a sequence is complete and the result is available in result register ATDDR0; CCF1 is set when the second conversion in a sequence is complete and the result is available in ATDDR1, and so forth.

The conversion complete flags are cleared depending on the setting of the fast flag clear bit (AFFC in ATDCTL2). When AFFC=0, the status register containing the conversion complete flag must be read as a precondition before the flag can be cleared. The flag is actually

cleared during a subsequent access to the result register. This provides a convenient method for clearing the conversion complete flag when the user is polling the ATD module; it ensures the user is signaled as to the availability of new data and avoids having to have the user clear the flag explicitly.

When $AFFC=1$, the conversion complete flags are cleared when their associated result registers are read; reading the status register is not a necessary condition in order to clear them. This is the easiest method for clearing the conversion complete flags which is useful when the ATD module signals conversion completion with interrupt signals.

The conversion complete flags are normally read only; in special (test) mode they can be written. Note for writing ATDCTL4/5 registers. When ATDCTL4/5 register is written, the SCF flags and all CCFx flags are cleared; any pending interrupt request is canceled.

**ATD TEST Module
Test Register
(ATDTEST)**

The test registers implement various special (test) modes used to test the ATD module. The reset bit in ATDTEST1 is always read/write. The SAR (successive approximation register) can always be read but only written in special (test) mode.

When writing to the SAR in special (test) mode, it is advised to use 16 bit write. Using an 8-bit write to ATDTEST0 will corrupt the SAR[1:0] (ATDTEST1 [7:6]) bits. This is a known bug.

The functions implemented by the test registers are reserved for factory test.

Address Offset: \$0008–\$0009

	Bit 15	14	13	12	11	10	9	Bit 8
	SAR9	SAR8	SAR7	SAR6	SAR5	SAR4	SAR3	SAR2
Reset:	1	0	0	0	0	0	0	0
	Bit 7	6	5	4	3	2	1	Bit 0
	SAR1	SAR0	0	0	0	RST	ATDCLK	SC
Reset:	0	0	0	0	0	0	0	0

SAR 9–0 — Successive Approximation Register

This ten bit value represents the contents of the AD machine’s successive approximation register. This value can always be read. It can only be written in special (test) mode. Note that ATDTEST0 acts as a ten bit register since the entire SAR is read/written when accessing this address.

RST — Test Mode Reset Bit

- 1 = Reset the ATD module.
- 0 = No reset.

When set, this bit causes the ATD module to reset itself. This resets all registers to their reset state (note the system reset state of the reset bit is zero), with the exception of the ADPU bit and itself. This also aborts the current conversion and conversion sequence, clears all pending interrupts, and puts the module in an idle mode.

Resetting to idle mode defines the only exception of the reset control bit condition to the general (bus) reset condition. The reset control bit does not initialize the ADPU bit to its reset condition and therefore does not power down the module. This exception allows the module to remain active for other test operations.

ATDCLK — Display the state of the ATD conversion clock

This bit can be used to display the state of the ATD conversion clock ATDCLK when in special mode. Note that this bit cannot be written to. Note further that ATDCLK will reset upon the start of a new conversion sequence.

SC — Special Channel Conversion Mode

- 1 = Perform special channel ATD conversion.
- 0 = Perform ATD conversion on an analog input channel.

SC determines if the ATD module performs ATD conversions on any of the analog input channels (normal operation) or whether it performs a conversion on one of the defined, special channels. The special channels are normally used to test the ATD machine and include converting the high and low reference potentials for the module. The control bits CC/CB/CA are used to indicate which special channels is to be converted. [Table 106](#) lists the currently available special channels. The last column in the table denote the expected digital code that should be generated by the special conversion for 8-bit resolution.

Table 106 Special Channel Conversion Select Coding

CC	CB	CA	Special Channel	Expected Digital Result Code
0	X	X	reserved	–
1	0	0	VRH	\$FF
1	0	1	VRL	\$00
1	1	0	$(VRH + VRL)/2$	\$80
1	1	1	reserved	–

**ATD Input Enable
Mask Register
(ATDDIEN)**

Address Offset: \$000D

	Bit 7	6	5	4	3	2	1	Bit 0
	Bit 7	Bit 6	Bit 5	Bit 4	Bit 3	Bit 2	Bit 1	Bit 0
Reset:	0	0	0	0	0	0	0	0

This register is added for controlling the PORTAD1. Each bit individually enables the corresponding digital input buffers of PORTAD1

- 1 = Enable digital input buffer
- 0 = Disable digital input buffer

This enable register confers the user greater control over the use of the ports. Note that when ATDDIEN enable bit is set, it will enable the input buffers continuously. The user is advised that if this bit is set while simultaneously using it as an analog port, the input buffer maybe in the linear region and therefore it may consume excessive power.

If the ATDDIEN bit is clear, a port read will return a “1”.

If the buffers are enabled during conversion, it will burn more power. The recommendation is to have buffers disabled during conversion. Due to internal synchronization circuits it can take up yo 2 bus cycles until the correct value is read on the PORTAD1 register.

Analog to Digital Converter

Port Data Register (PORTAD1)

The input data port associated with the ATD module is input-only. The port pins are shared with the analog A/D inputs.

Address Offset: \$000F

	Bit 7	6	5	4	3	2	1	Bit 0
	Bit 7	Bit 6	Bit 5	Bit 4	Bit 3	Bit 2	Bit 1	Bit 0
Pin Function	AN7	AN6	AN5	AN4	AN3	AN2	AN1	AN0

Reset: Reading this register out of reset will result in a “1” unless the pin was enabled by setting the respective bit in the ATDDIEN register, which is cleared out of reset.

The ATD input ports may be used for general purpose digital input. When the port data registers are read, they contain the digital levels appearing on the input pins at the time of the read. Input pins with signal potentials not meeting V_{IL} or V_{IH} specifications will have an indeterminate value.

Use of any Port pin for digital input does not preclude the use of any other Port pin for analog input. Note that the digital/analog multiplexing function is performed in the input pad. The port registers are connected to the input pads through a tristate buffers. These buffers are only activated when a read to a port register is performed so that analog signal potentials on the input pins will not cause the buffers to draw excess supply current.

Writes to this register have no meaning at any time.

**ATDDR_x A/D
Conversion Result
Registers
(ATDDR₀–15)**

Left Justified Result Data

Address Offset: \$_01(2x)

ATDDR _x H	Bit 15	14	13	12	11	10	9	Bit 8
10-bit data	Bit 9 MSB	Bit 8	Bit 7	Bit 6	Bit 5	Bit 4	Bit 3	Bit 2
8-bit data	Bit 7 MSB	Bit 6	Bit 5	Bit 4	Bit 3	Bit 2	Bit 1	Bit 0
RESET	U	U	U	U	U	U	U	U

Address Offset: \$_01(2x+1)

ATDDR _x L	Bit 7	6	5	4	3	2	1	Bit 0
10-bit data	Bit 1	Bit 0	0	0	0	0	0	0
8-bit data	1	0	0	0	0	0	0	0
RESET	U	U	U	U	U	U	U	U

Right Justified Result Data

Address Offset: \$_01(2x)

ATDDR _x H	Bit 15	14	13	12	11	10	9	Bit 8
10-bit data	0	0	0	0	0	0	Bit 9 MSB	Bit 8
8-bit data	0	0	0	0	0	0	0	0
RESET	U	U	U	U	U	U	U	U

Address Offset: \$_01(2x+1)

ATDDR _x L	Bit 7	6	5	4	3	2	1	Bit 0
10-bit data	Bit 7	Bit 6	Bit 5	Bit 4	Bit 3	Bit 2	Bit 1	Bit 0
8-bit data	Bit 7 MSB	Bit 6	Bit 5	Bit 4	Bit 3	Bit 2	Bit 1	Bit 0
RESET	U	U	U	U	U	U	U	U

$x = 0, 1, 2, 3, 4, 5, 6, 7$

The A/D conversion results are stored in 8 result registers. These registers are designated ATDDR₀ through ATDDR₇. The number of result registers in a particular version of the ATD module equals the number of analog input channels.

The result data is formatted in the result registers based on two criteria. First there is left and right justification; this selection is made using the DJM control bit in ATDCTL2. Second there is signed and unsigned data;

this selection is made using the DSGN control bit in ATDCTL2. Note that the signed data is stored in 2s complement format. Note that signed data only exists in left justified format so that no sign extension hardware is required. Signed data selected for right justified format is ignored.

For 8-bit result data, the result data maps between the high (left justified) and low (right justified) order bytes of the result register. For 10-bit result data, the result data maps between bits 6–15 (left justified) and bits 0–9 (right justified) of the result register. Therefore for each bit in the SAR, there are 3 possible mappings of this bit into the result registers.

These registers are normally read-only. In special (test) mode the result registers can be written.

External Pin Descriptions

The basic ATD requires a total of 12 pins to implement the 8 input channel A/D converter. The pins fall into four categories: channel input pins (one of the channel input pins is muxed with the ETRIG input), reference potential pins (VRL and VRH), and analog supply potential pins (VDDA and VSSA). These pins are described below.

Channel Pins

The 8 channel pins serve three purposes.

First, the channel pins are used as the analog input pins of the ATD. Each pin is connected to an analog switch which serves as the signal gate into the sample submodule.

Second, the channel pins can also be used to collect general purpose digital input data. The digital data must meet the V_{IH} and V_{IL} specifications. The channel pins are also connected to the input of a Schmitt Trigger which drives the digital data to the Port Data Register (PORTAD1). The Schmitt Trigger is disabled when the respective ATDDIEN bit is set to “0”. The digital input data is accessed via the PORTAD1 Registers. Since the port PORTAD1 pins are used only as inputs in normal operating modes, no data direction register is necessary for this port.

Third, channel 7 pin is used to provide the external trigger signal to the module. The ATDDIEN bit 7 must be set to enable schmitt trigger input buffer.

External Trigger Input Pin (ETRIG)

As a module variability, the ETRIG pin may occupy a separate pin, or the channel 7 pin may be used to provide the external trigger input signal when the external trigger mode is enabled. External trigger mode is enabled using the control bits in the ATDCTL2 register. Triggering is synchronized to the ATD module clock; when a active falling or rising edge on the trigger signal or the correct level is detected, a new conversion cycle begins.

Analog to Digital Converter

Analog Reference Pins

These two pins serve as the source for the high (V_{RH}) and low (V_{RL}) reference potentials for the converter.

Separation from the power supply pins accommodates the filtering necessary to achieve the accuracy of which the system is capable.
Dedicated Analog Supply Pins

These two pins are used to supply power (V_{DDA} and V_{SSA}) to the analog section of the chip. Dedicated power is required to isolate the sensitive analog circuitry from the normal levels of noise present on the digital power supply.

Reset Initialization

The reset state of each individual bit is listed within the Register Description section (see Register Descriptions) which details the registers and their bit-fields. All special functions or modes which are initialized during or just following reset are described within this section.

Modes of Operation

Analog to digital conversions in this module are performed in sequences. There are a variety of different sequences that are programmable; these different sequences are referred to as conversion modes¹. A particular conversion mode is defined by how many A/D conversions are performed in a sequence, which analog input channels are examined during a sequence, sample time length, whether sequences are performed continuously or not, what event is used to trigger a conversion, result register assignments, and so on.

The conversion modes for the ATD module are defined by the settings of four control bits and three control values. The control bits are ETRIGE in ATDCTL2 and MULT, SCAN and SC in ATDCTL5. In brief, ETRIGE controls whether an external trigger is used to start a conversion sequence. MULT controls whether the sequence examines a single analog input channel or scans a number of different channels. SCAN determines if sequences are performed continuously. SC determines if we are performing a special conversion (i.e.: convert V_{rl} , V_{rh} , $(V_{rl}+V_{rh})/2$, usually used for test purposes). The control values are bits CC/CB/CA in ATDCTL3/5 which define the input channels to be examined; S8C/S1C in ATDCTL3/5 define the number of conversions in a sequence; SMP0/SMP1 in ATDCTL4 define the length of the sample time.

Sequences are initiated by writing to control registers 4 and 5. For the continuous sequence modes, conversions will not stop until either another non-continuous conversion sequence is initiated and finishes, the ATD is powered down (ADPU control bit), the ATD is reset (by the bus or the control bit), the bus **ipg_wait** line is activated (if the wait bit is activated), or the bus **ipg_stop** line is activated. Note that the **ipg_wait** signal suspends the current conversion until the **ipg_wait** is deactivated - it does not terminate the conversion. The result of suspended conversion is not guaranteed.

The MCU can use one of two methods to learn when the result data is available in the result registers. First, the interrupt enable bit can be used to interrupt the MCU when the sequence is complete. Second, the conversion complete flags can be used to poll the ATD module to

determine when the result registers have been filled. The SCF bit is set after the completion of each sequence. The CCF bit associated with each result register is set when that register is loaded with result data.

1) Do not confuse **conversion modes** with **MCU operating modes** such as STOP, WAIT, IDLE, RUN, DEBUG, and SPECIAL (test) modes, and do not confuse with **module defined operating modes** such as power down, fast flag clear, 8-bit resolution, 10-bit resolution, interrupt enable, clock prescaler setting, and freeze modes, and finally do not confuse with **module result data formats** such as right justify mode, left justify mode, and signed/unsigned data.

Special Operation Special mode is a device test mode. Special mode is entered when the IP **ipbi_test_mod** signal is asserted. This mode allows increased access to the control, status, and test registers. A number of special mode test functions are also available.

Run Mode RUN mode for the ATD module is defined as the state where the ATD module is powered up and currently performing an A/D conversion. Complete access to all control, status, and result registers is available. The module is consuming maximum power.

Wait Mode WAIT mode is a maskable form of power saving.

WAIT mode is signalled to the ATD by asserting the **ipg_wait** signal on the bus. If the AWAI control bit in ATDCTL2 is set, then the ATD responds to WAIT mode. If the AWAI control bit is clear, then the ATD ignores the **ipg_wait** signal. The ATD response to the wait mode is to power down the module. The module is released from WAIT mode when the **ipg_wait** signal is released.

In this mode, the MCU does *not* have access to the control, status, or result registers.

Stop Mode STOP mode is a global mode that can be used to place the entire device into power saving operation.

STOP mode is signalled to the ATD by asserting the **ipg_stop** signal. This causes the ATD module to power down the ATD module. The digital

clocks are disabled to most of the module and the analog quiescent current draw is turned off; this places the module into its power down state. This mode is equivalent to clearing the ADPU control bit in ATDCTL2. The module is released from STOP mode when the **ipg_stop** signal is released.

In this mode, the MCU still has access to the control, status, and result registers.

IDLE Mode

IDLE mode for the ATD module is defined as the state where the ATD module is powered up and ready to perform an A/D conversion, but not actually performing a conversion at the present time. Complete access to all control, status, and result registers is available. The module is consuming near maximum power.

Sample Conversion

The sample/conversion time has three components: the initial sample time, the final sample time, and resolution time. The initial sample time is fixed at 2 ATD clock cycles. The final sample time is programmable through control register ATDCTL 4 and can be 2, 4, 8, or 16 ATD clock cycles long. For a 10-bit conversion, the resolution time is 10 ATD clock cycles.

[Figure 112](#) illustrates how an ATD sample/conversion period is broken into its various components for an 10-bit conversion with a programmable sample time of 2 ATD clock cycles.

Analog to Digital Converter

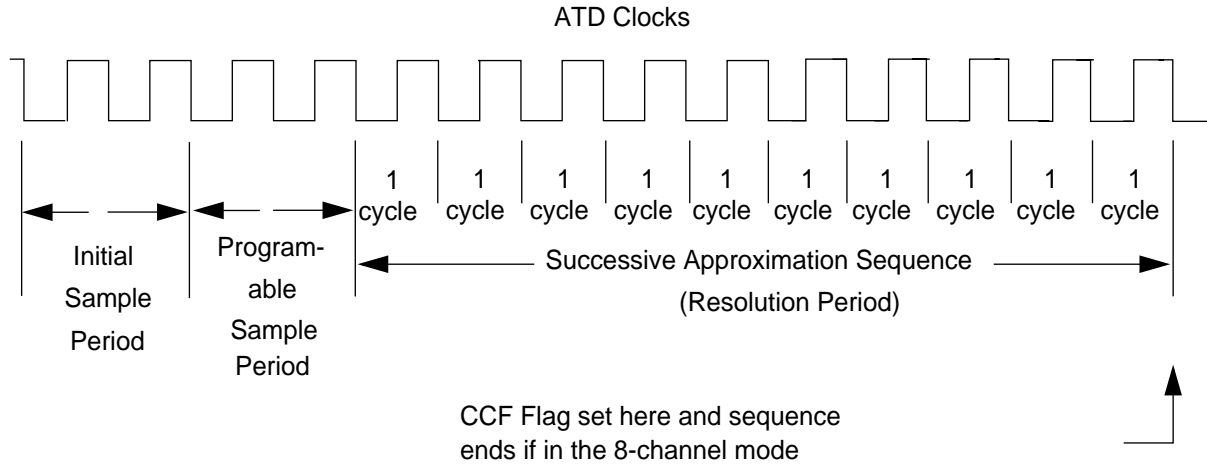

Figure 112 ATD Sample/Conversion Timing – 10 bit conversion, 2 cycle programmable sample period

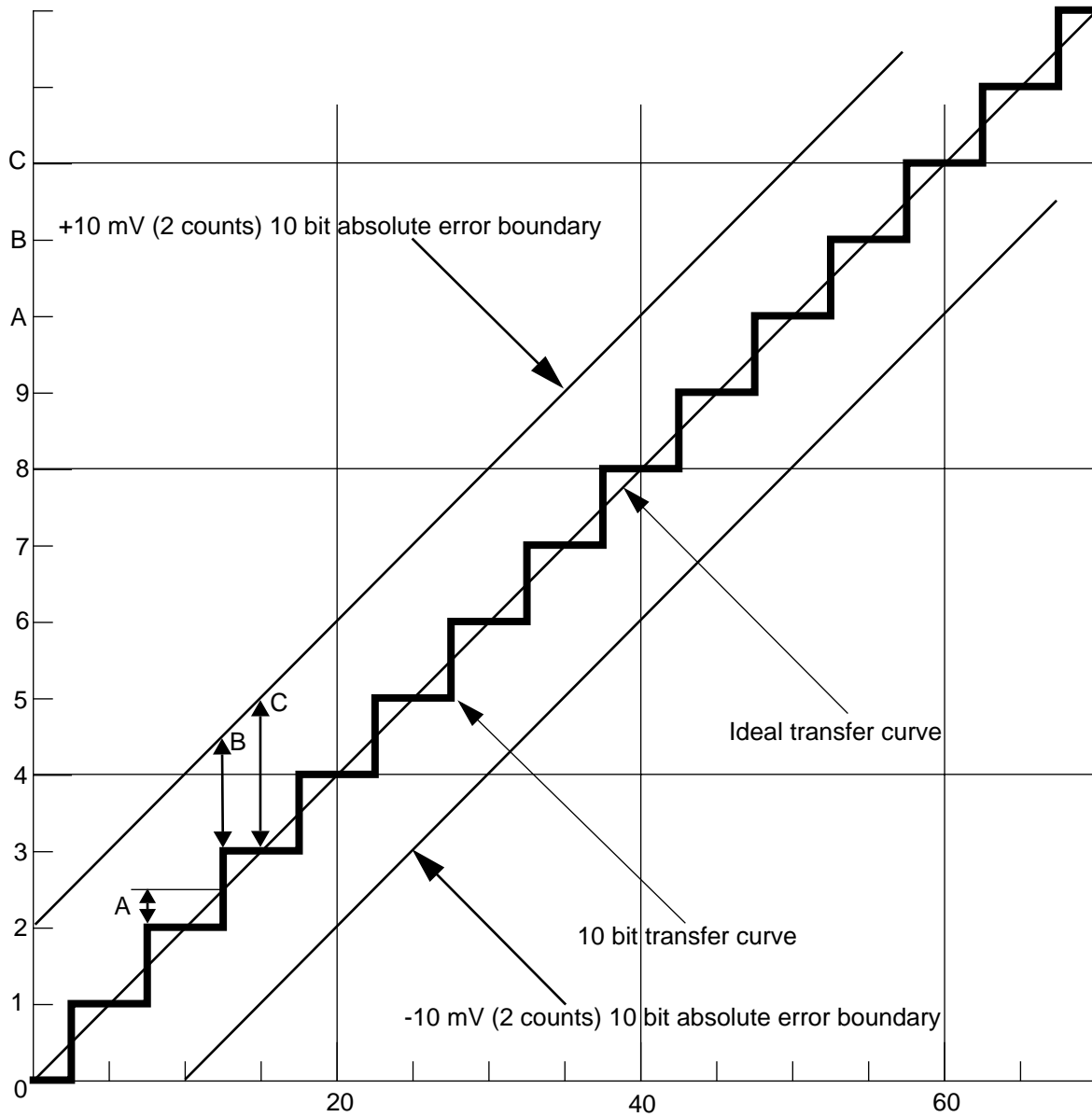

Figure 113 ATD Accuracy Definitions

NOTES *Example:*

- 1) Input in millivolts, $V_{REFH} - V_{REFL} = 5.120$ Volts
- 2) one 10-Bit count = 5 mV.
- 3) A = inherent 10-Bit quantization error OF 2.5mV
- 4) B = circuit-contributed +7.5mV ERROR
- 5) C = +10mV absolute error equals 2 10-Bit counts

General Purpose Input Ports

The input channel pins can be multiplexed between analog and digital data. As analog inputs, they are multiplexed and sampled to supply signals to the A/D converter. As digital inputs, they supply external input data that can be accessed through the digital port registers. Each digital input is individually enabled by each bit of the register ATDDIEN.

The analog/digital multiplex operation is performed in the input pads. The input pad is always connected to the analog inputs of the ATD module. The input pad signal is buffered before the data is bussed to the digital port registers. The buffer is a schmitt trigger nand gate so that the buffer can be turned off. This is important so that the buffer does not draw excess current when analog potentials are presented at its input. This is particularly important when some of the inputs are being used as digital inputs and some as analog inputs. Analog signals present on the input pins at the digital sampling time that don't meet the V_{IL} or V_{IH} specification will return unknown digital values. A read of the PORTAD1 may affect the accuracy of an in progress sample period but will not affect an in progress A/D conversion.

There is a digital, 8-bit, input-only port associated with the ATD. It is accessed through the 8-bit Port Data Registers (PORTAD1). The number of bits utilized in the port register depends on the number of analog channels implemented with the 8 channel ATD module.

Byte Data Link Controller Module

Contents

Overview	603
Features	604
Block Diagram	605
Register Map	606
Functional Description	607
Register Descriptions	633
External Pin Descriptions	653
Reset Initialization/Basic Operation	653
Transmitting A Message	658
Receiving A Message	664
Transmitting An In-Frame Response (IFR)	669
Receiving An In-Frame Response (IFR)	681
Special BDLC Operations	683
Modes of Operation	684
Interrupt Operation	689
Low Power Options	689

Overview

The BDLC module is a serial communication module which allows the user to send and receive messages across a Society of Automotive Engineers (SAE) J1850 serial communication network. The user's software handles each transmitted or received message on a byte-by-byte basis, while the BDLC performs all of the network access, arbitration, message framing and error detection duties.

It is recommended that the reader be familiar with the operation and requirements of the SAE J1850 protocol as described in the document

“SAE Standard J1850 Class B Data Communications Network Interface” prior to proceeding with this specification.

The BDLC module is designed in a modular structure for use as an IP block.

Features

Features of the BDLC module include the following:

- SAE J1850 Class B Data Communications Network Interface Compatible and ISO Compatible for Low-Speed (≤ 125 Kbps) Serial Data Communications in Automotive Applications
- 10.4 Kbps Variable Pulse Width (VPW) Bit Format
- Digital Noise Filter
- Collision Detection
- Hardware Cyclical Redundancy Check (CRC) Generation and Checking
- Block Mode Receive and Transmit Supported
- 4X Receive Mode, 41.6 Kbps, Supported
- Digital Loopback Mode
- In-Frame Response (IFR) Types 0, 1, 2, and 3 Supported
- Dedicated Register for Symbol Timing Adjustments
- IP Bus Interface
- Power-Saving Stop and Wait Modes with Automatic Wakeup on Network Activity
- Polling and CPU Interrupt Generation with Vector Lookup Available

Block Diagram

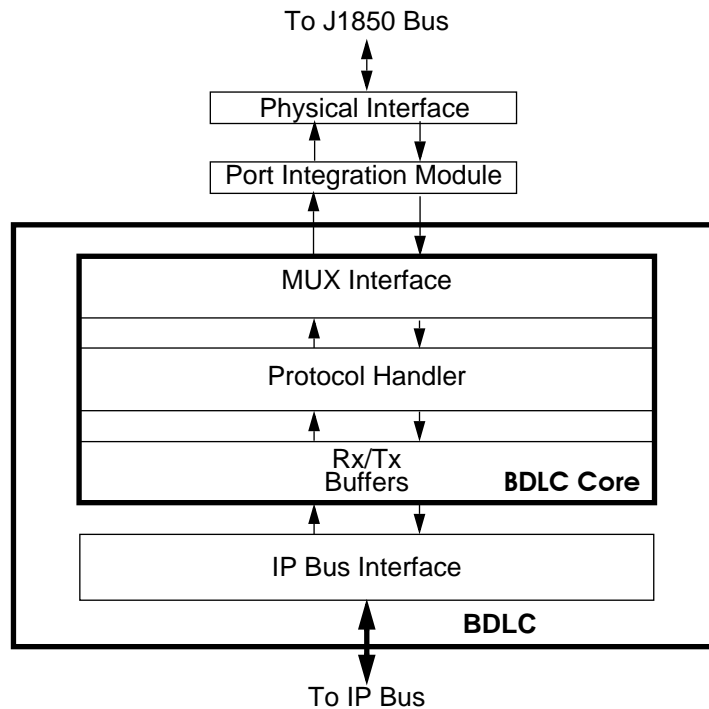

Figure 114 BDLC Block Diagram

Figure 107 shows the organization of the BDLC module. The IP Bus Interface provides the link between the IP Bus and the Buffers. The Buffers provide storage for data received and data to be transmitted onto the J1850 bus. The Protocol Handler is responsible for the encoding and decoding of data bits and special message symbols during transmission and reception. The MUX Interface provides the link between the BDLC digital section and the analog Physical Interface. The wave shaping, driving and digitizing of data is performed by the Physical Interface.

NOTE: *The Physical Interface is not implemented in the BDLC and must be provided externally.*

The main functional blocks of the BDLC are explained in greater detail in the following sections.

Use of the BDLC module in message networking fully implements the “SAE Standard J1850 Class B Data Communication Network Interface” specification.

Register Map

Reg Name		Bit 7	6	5	4	3	2	1	Bit 0
DLCBCR1	Read:	IMSG	CLKS	0	0	0	0	IE	WCM
	Write:								
	Reset:	1	1	0	0	0	0	0	0
DLCBSVR	Read:	0	0	I3	I2	I1	I0	0	0
	Write:								
	Reset:	0	0	0	0	0	0	0	0
DLCBCR2	Read:	SMRST	DLOOP	RX4XE	NBFS	TEOD	TSIFR	TMIFR1	TMIFR0
	Write:								
	Reset:	0	1	0	0	0	0	0	0
DLCBDR	Read:	D7	D6	D5	D4	D3	D2	D1	D0
	Write:								
	Reset:	0	0	0	0	0	0	0	0
DLCBARD	Read:	0	RXPOL	0	0	BO3	BO2	BO1	BO0
	Write:								
	Reset:	0	1	0	0	0	1	1	1
DLCBRSR	Read:	0	0	R5	R4	R3	R2	R1	R0
	Write:								
	Reset:	0	0	0	0	0	0	0	0
DLCSCR	Read:	0	0	0	BDLCE	0	0	0	0
	Write:								
	Reset:	0	0	0	0	0	0	0	0
DLCBSTAT	Read:	0	0	0	0	0	0	0	IDLE
	Write:	Unimplemented				Reserved		Unimplemented	
	Reset:	0	0	0	0	0	0	0	0

Table 107 BDLC Register Address Summary

Register	DLCBCR1	DLCBSVR	DLCBCR2	DLCBDR
Address Offset	\$_00	\$_01	\$_02	\$_03
Register	DLCBARD	DLCBRSR	DLCSCR	DLCBSTAT
Address Offset	\$_04	\$_05	\$_06	\$_07

Functional Description

Mux Interface The MUX Interface is responsible for bit encoding/decoding and digital noise filtering between the Protocol Handler and the Physical Interface.

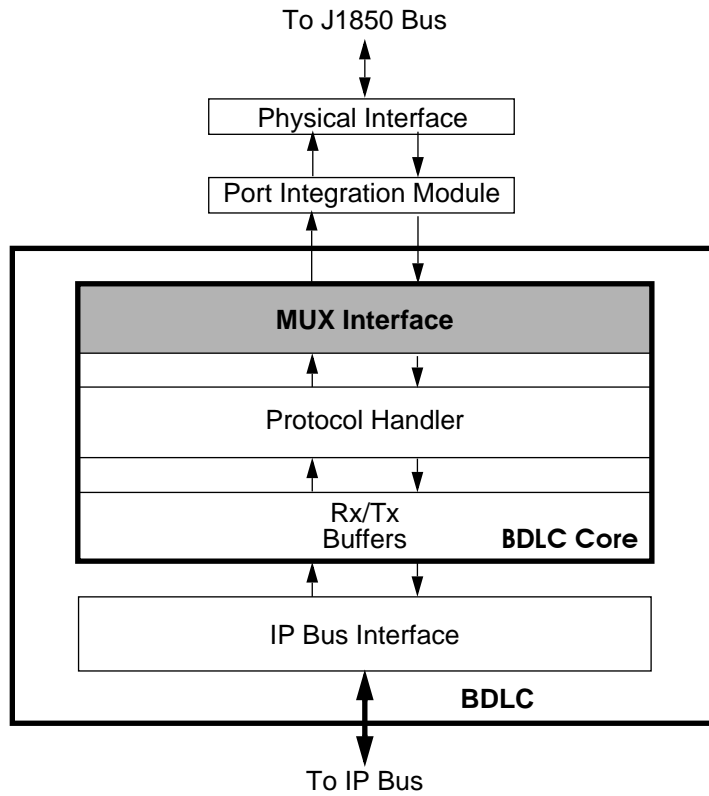

Figure 115 BDLC Block Diagram – Mux Interface

Rx Digital Filter

The Receiver section of the BDLC includes a digital low pass filter to remove narrow noise pulses from the incoming message. An outline of the digital filter is shown in [Figure 116](#).

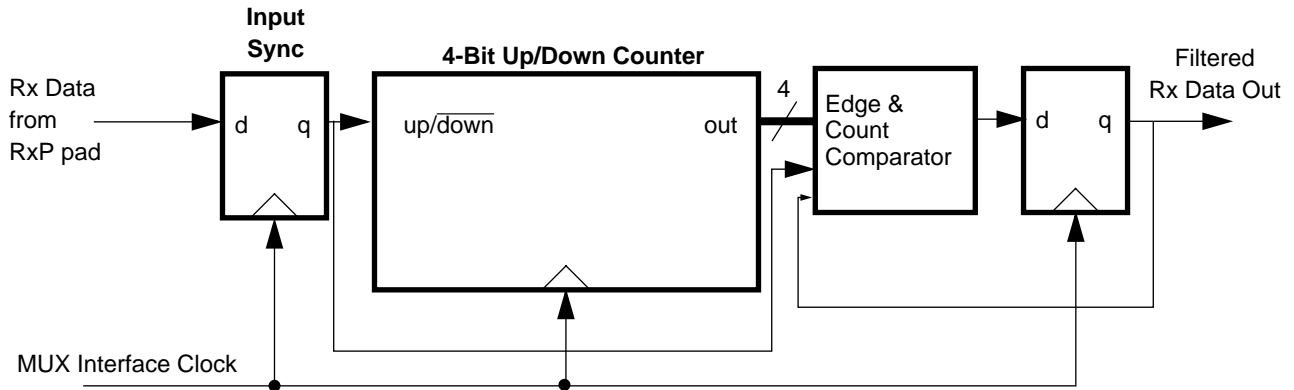

Figure 116 BDLC Rx Digital Filter Block Diagram

Operation

The clock for the digital filter is provided by the MUX Interface clock. At each positive edge of the clock signal, the current state of the Receiver input signal from the RxP pad is sampled. The RxP signal state is used to determine whether the counter should increment or decrement at the next positive edge of the clock signal.

The counter will increment if the input data sample is high but decrement if the input sample is low. The counter will thus progress up towards '15' if, on average, the RxP signal remains high or progress down towards '0' if, on average, the RxP signal remains low.

When the counter eventually reaches the value '15', the digital filter decides that the condition of the RxP signal is at a stable logic level one and the Data Latch is set, causing the Filtered Rx Data signal to become a logic level one. Furthermore, the counter is prevented from overflowing and can only be decremented from this state.

Alternatively, should the counter eventually reach the value '0', the digital filter decides that the condition of the RxP signal is at a stable logic level zero and the Data Latch is reset, causing the Filtered Rx Data signal to become a logic level zero. Furthermore, the counter is prevented from underflowing and can only be incremented from this state.

The Data Latch will retain its value until the counter next reaches the opposite end point, signifying a definite transition of the RxP signal.

Performance

The performance of the digital filter is best described in the time domain rather than the frequency domain.

If the signal on the RxP signal transitions, then there will be a delay before that transition appears at the Filtered Rx Data output signal. This delay will be between 15 and 16 clock periods, depending on where the transition occurs with respect to the sampling points. This ‘filter delay’ must be taken into account when performing message arbitration.

For example, if the frequency of the MUX Interface clock (f_{bdlc}) is 1.0486MHz, then the period (t_{bdlc}) is 954ns and the maximum filter delay in the absence of noise will be 15.259us.

The effect of random noise on the RxP signal depends on the characteristics of the noise itself. Narrow noise pulses on the RxP signal will be completely ignored if they are shorter than the filter delay. This provides a degree of low pass filtering.

If noise occurs during a symbol transition, the detection of that transition may be delayed by an amount equal to the length of the noise burst. This is just a reflection of the uncertainty of where the transition is truly occurring within the noise.

Noise pulses that are wider than the filter delay, but narrower than the shortest allowable symbol length will be detected by the next stage of the BDLC’s receiver as an invalid symbol.

Noise pulses that are longer than the shortest allowable symbol length will normally be detected as an invalid symbol or as invalid data when the frame’s CRC is checked.

J1850 Frame Format

All messages transmitted on the J1850 bus are structured using the format:

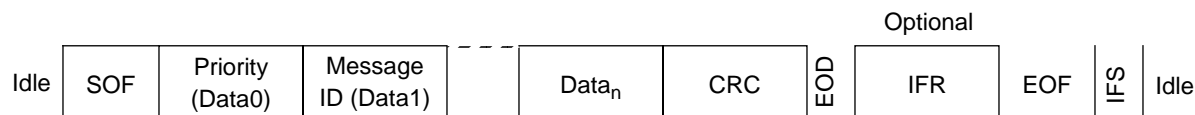

Figure 117 J1850 Bus Message Format (VPW)

SAE J1850 states that each message has a maximum length of 101 bit times or 12 bytes (excluding SOF, EOD, NB and EOF).

SOF – Start of Frame Symbol

All messages transmitted onto the J1850 bus must begin with an long active SOF symbol. This indicates to any listeners on the J1850 bus the start of a new message transmission. The SOF symbol is not used in the CRC calculation.

Data – In Message Data Bytes

The data bytes contained in the message include the message priority/type, message I.D. byte, and any actual data being transmitted to the receiving node. The message format used by the BDLC is similar to the 3 Byte Consolidated Header message format outlined by the SAE J1850 document. See SAE J1850 – Class B Data Communications Network Interface, for more information about 1 and 3 Byte Headers.

Messages transmitted by the BDLC onto the J1850 bus must contain at least one data byte, and therefore can be as short as one data byte and one CRC byte. Each data byte in the message is 8 bits in length, transmitted MSB to LSB.

CRC – Cyclical Redundancy Check Byte

This byte is used by the receiver(s) of each message to determine if any errors have occurred during the transmission of the message. The BDLC calculates the CRC byte and appends it onto any messages transmitted onto the J1850 bus, and also performs CRC detection on any messages it receives from the J1850 bus.

CRC generation uses the divisor polynomial $X^8+X^4+X^3+X^2+1$. The remainder polynomial is initially set to all ones, and then each byte in the message after the SOF symbol is serially processed through the CRC generation circuitry. The one's complement of the remainder then

becomes the 8-bit CRC byte, which is appended to the message after the data bytes, in MSB to LSB order.

When receiving a message, the BDLC uses the same divisor polynomial. All data bytes, excluding the SOF and EOD symbols, but including the CRC byte, are used to check the CRC. If the message is error free, the remainder polynomial will equal $X^7+X^6+X^2$ (\$C4), regardless of the data contained in the message. If the calculated CRC does not equal \$C4, the BDLC will recognize this as a CRC error and set the CRC error flag in the BSVR register.

EOD – End of Data Symbol

The EOD symbol is a long passive period on the J1850 bus used to signify to any recipients of a message that the transmission by the originator has completed. No flag is set upon reception of EOD symbol.

IFR – In Frame Response Bytes

The IFR section of the J1850 message format is optional. Users desiring further definition of in-frame response should review the “SAE J1850 Class B Data Communications Network Interface” specification.

EOF – End of Frame Symbol

This symbol is a passive period on the J1850 bus, longer than an EOD symbol, which signifies the end of a message. Since an EOF symbol is longer than an EOD symbol, if no response is transmitted after an EOD symbol, it becomes an EOF, and the message is assumed to be completed. The EOF flag is set upon receiving the EOF symbol.

IFS – Inter-Frame Separation Symbol

The IFS symbol is a passive period on the J1850 bus which allows proper synchronization between nodes during continuous message transmission. The IFS symbol is transmitted by a node following the completion of the EOF period.

When the last byte of a message has been transmitted onto the J1850 bus, and the EOF symbol time has expired, all nodes must then wait for the IFS symbol time to expire before transmitting an SOF, marking the beginning of another message.

However, if the BDLC is waiting for the IFS period to expire before beginning a transmission and a rising edge is detected before the IFS time has expired, it will internally synchronize to that edge.

A rising edge may occur during the IFS period because of varying clock tolerances and loading of the J1850 bus, causing different nodes to observe the completion of the IFS period at different times. Receivers must synchronize to any SOF occurring during an IFS period to allow for individual clock tolerances.

Break

If the BDLC is transmitting at the time a BREAK is detected, it treats the BREAK as if a transmission error had occurred, and halts transmission. The BDLC cannot transmit a BREAK symbol. If while receiving a message the BDLC detects a BREAK symbol, it treats the BREAK as a reception error and sets the invalid symbol flag. If while receiving a message in 4X mode, the BDLC detects a BREAK symbol, it treats the BREAK as a reception error, sets BSVR register to \$1C, and exits 4X mode. The RX4XE bit in BCR2 is automatically cleared upon reception of the BREAK symbol.

Idle Bus

An idle condition exists on the bus during any passive period after expiration of the IFS period. Any node sensing an idle bus condition can begin transmission immediately.

J1850 VPW Symbols

Variable Pulse Width modulation (VPW) is an encoding technique in which each bit is defined by the time between successive transitions, and by the level of the bus between transitions, active or passive. Active and passive bits are used alternately. This encoding technique is used to reduced the number of bus transitions for a given bit rate.

The symbol values shown below are nominal values. Refer to the electrical specification for a more complete description of symbol values. Each logic one or logic zero contains a single transition, and can be at either the active or passive level and one of two lengths, either 64 μ s or 128 μ s (T_{NOM} at 10.4kbps baud rate), depending upon the encoding of the previous bit. The SOF, EOD, EOF and IFS symbols will always be encoded at an assigned level and length. See [Figure 118](#).

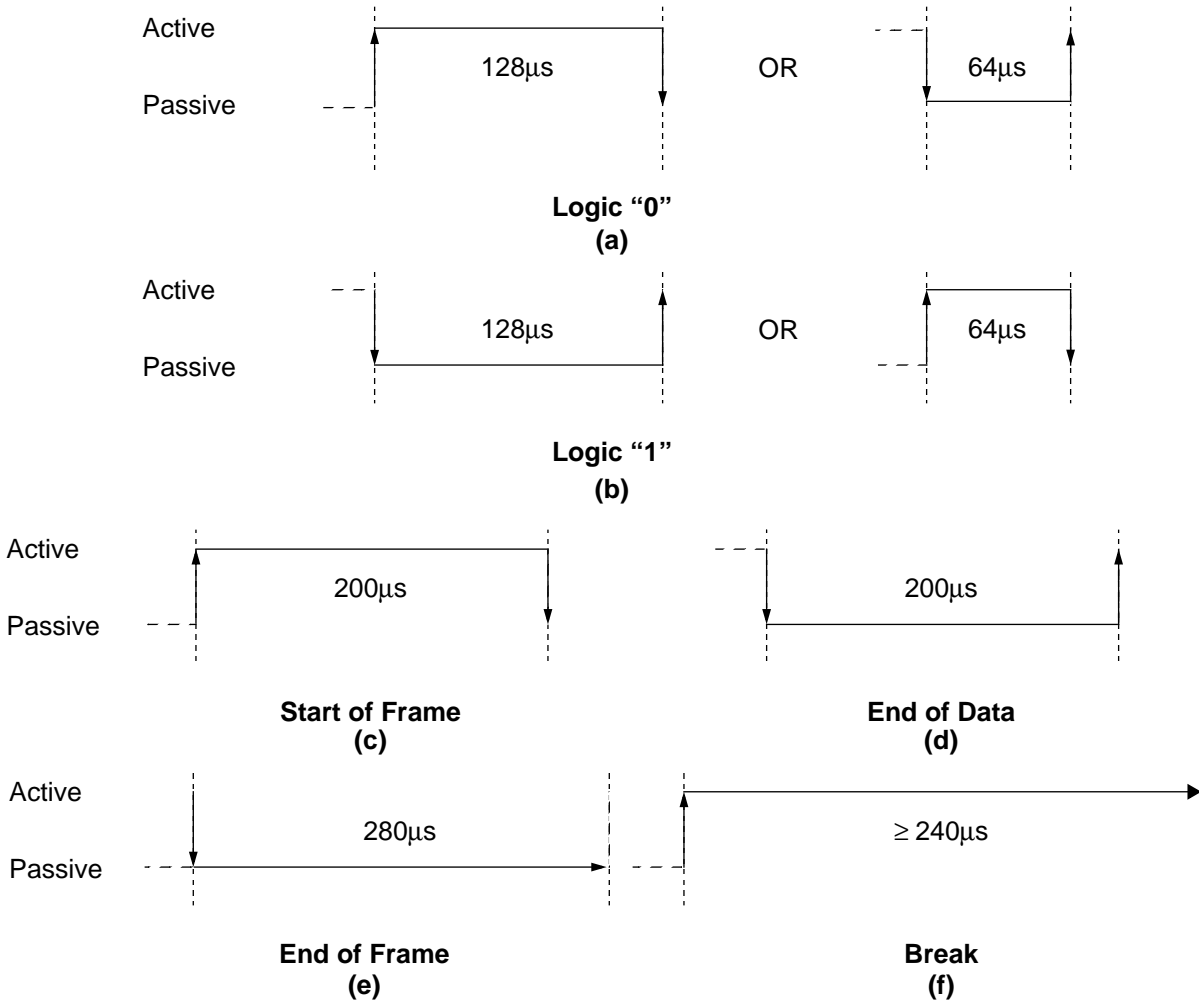

Figure 118 J1850 VPW Symbols

Each message will begin with an SOF symbol, an active symbol, and therefore each data byte (including the CRC byte) will begin with a passive bit, regardless of whether it is a logic one or a logic zero. All VPW bit lengths stated in the following descriptions are typical values at a 10.4kbps bit rate.

Logic "0"

A logic zero is defined as either an active to passive transition followed by a passive period 64μs in length, or a passive to active transition followed by an active period 128μs in length (Figure 118(a)).

Byte Data Link

<i>Logic "1"</i>	A logic one is defined as either an active to passive transition followed by a passive period 128 μ s in length, or a passive to active transition followed by an active period 64 μ s in length (Figure 118(b)).
<i>NB – Normalization Bit</i>	The NB symbol has the same property as a logic "1" or a logic "0". It is only used in IFR message responses.
<i>SOF -- Start of Frame Symbol</i>	The SOF symbol is defined as passive to active transition followed by an active period 200 μ s in length (Figure 118(c)). This allows the data bytes which follow the SOF symbol to begin with a passive bit, regardless of whether it is a logic one or a logic zero.
<i>EOD – End of Data Symbol</i>	The EOD symbol is defined as an active to passive transition followed by a passive period 200 μ s in length (Figure 118(d)).
<i>EOF – End of Frame Symbol</i>	The EOF symbol is defined as an active to passive transition followed by a passive period 280 μ s in length (Figure 118(e)). If there is no IFR byte transmitted after an EOD symbol is transmitted, after another 80 μ s the EOD becomes an EOF, indicating the completion of the message.
<i>IFS – Inter-Frame Separation Symbol</i>	The IFS symbol is defined as a passive period 300 μ s in length. The IFS symbol contains no transition, since when used it always follows an EOF symbol.
<i>BREAK – Break Signal</i>	The BREAK signal is defined as a passive to active transition followed by an active period of at least 240 μ s (Figure 118(f)).
<i>IDLE</i>	An IDLE is defined as a passive period greater than 300 μ s in length.
<i>J1850 VPW Valid/Invalid Bits & Symbols</i>	<p>The timing tolerances for receiving data bits and symbols from the J1850 bus have been defined to allow for variations in oscillator frequencies. In many cases the maximum time allowed to define a data bit or symbol is equal to the minimum time allowed to define another data bit or symbol.</p> <p>Since the minimum resolution of the BDLC for determining what symbol is being received is equal to a single period of the MUX Interface clock,</p>

(t_{bdlc}) an apparent separation in these maximum time/minimum time concurrences equal to one cycle of t_{bdlc} occurs.

This one clock resolution allows the BDLC to properly differentiate between the different bits and symbols, without reducing the valid window for receiving bits and symbols from transmitters onto the J1850 bus having varying oscillator frequencies.

In VPW bit encoding, the tolerances for the both passive and active data bits and symbols are defined with no gaps between definitions. For example, the maximum length of a passive logic zero is equal to the minimum length of a passive logic one, and the maximum length of an active logic zero is equal to the minimum length of a valid SOF symbol.

*Transmit and
Receive Symbol
Timing
Specifications*

Tables 108 through 113 contain the SAE J1850 transmit and receive symbol timing specifications for the BDLC. The units used in these tables are mux interface clock periods (t_{bdlc}). The mux interface clock is a divided down version of the IP bus clock input to the module (see [BDLC Rate Select Register \(DLCBRSR\)](#)). The mux interface clock drives the transmit and receive counters which control symbol generation and identification. The symbol timing in effect during J1850 operations is dependent the state of two control bits: the CLKS bit DLCBCR1, which indicates whether the IP bus clock is an integer frequency or a binary frequency; the RX4XE bit in DLCBCR2, which is used to select 4X receiver operation.

Tables 108 and 110 indicate the transmit and receive timing for integer IP bus frequencies (CLKS = 0) and 4X receive operation disabled (RX4XE = 0). It is assumed that for integer bus frequencies the divided down mux interface clock frequency will be 1MHz ($t_{\text{bdlc}} = 1 \mu\text{s}$).

Tables 109 and 111 indicated the transmit and receive timing for binary IP bus frequencies (CLKS = 1) and 4X receive operation disabled (RX4XE = 0). It is assumed that for binary bus frequencies the divided down mux interface clock frequency will be 1.048576 MHz ($t_{\text{bdlc}} = 0.953674 \mu\text{s}$). The symbol timing values are adjusted to compensate for the shortening of the mux interface clock period.

Tables 112 and 113 show how the receive symbol timing values are adjusted when 4X receive operation is enabled (RX4XE = 1) for both

integer bus frequencies (CLKS = 0) and binary bus frequencies (CLKS = 1), respectively.

The values specified in the tables are for the symbols appearing on the SAE J1850 bus. These values assume the BDLC is communicating on the SAE J1850 bus using an external analog transceiver, and that the BDLC analog roundtrip delay value programmed into the DLCBARD register is the appropriate value for the transceiver being used. If these conditions are not met, the symbol timings being measured on the SAE J1850 bus will be significantly affected. For a detailed description of how symbol timings are measured on the SAE J1850 bus, refer to the appropriate SAE documents.

Table 108 BDLC Transmitter VPW Symbol Timing for Integer Frequencies

Number	Characteristic	Symbol	Min	Typ	Max	Unit
1	Passive Logic 0	T_{tvp1}	62	64	66	t_{bdlc}
2	Passive Logic 1	T_{tvp2}	126	128	130	t_{bdlc}
3	Active Logic 0	T_{tva1}	126	128	130	t_{bdlc}
4	Active Logic 1	T_{tva2}	62	64	66	t_{bdlc}
5	Start of Frame (SOF)	T_{tva3}	198	200	202	t_{bdlc}
6	End of Data (EOD) ¹	T_{tvp3}	162	164	166	t_{bdlc}
7	End of Frame (EOF) ¹	T_{tv4}	238	240	242	t_{bdlc}
8	Inter-Frame Separator (IFS) ¹	T_{tv5}	298	300	302	t_{bdlc}

NOTE:

1. The transmitter timing for this symbol depends upon the minimum detection time of the symbol by the receiver.

Table 109 BDLC Transmitter VPW Symbol Timing for Binary Frequencies

Number	Characteristic	Symbol	Min	Typ	Max	Unit
1	Passive Logic 0	T_{tvp1}	65	67	69	t_{bdlc}
2	Passive Logic 1	T_{tvp2}	132	134	136	t_{bdlc}
3	Active Logic 0	T_{tva1}	132	134	136	t_{bdlc}
4	Active Logic 1	T_{tva2}	65	67	69	t_{bdlc}
5	Start of Frame (SOF)	T_{tva3}	208	210	212	t_{bdlc}
6	End of Data (EOD) ¹	T_{tvp3}	170	172	174	t_{bdlc}
7	End of Frame (EOF) ¹	T_{tv4}	250	252	254	t_{bdlc}
8	Inter-Frame Separator (IFS) ¹	T_{tv5}	313	315	317	t_{bdlc}

NOTE:
 1. The transmitter timing for this symbol depends upon the minimum detection time of the symbol by the receiver.

Table 110 BDLC Receiver VPW Symbol Timing for Integer Frequencies

Number	Characteristic	Symbol ¹	Min	Typ	Max	Unit
1	Passive Logic 0	T_{rvp1}	32	64	95	t_{bdlc}
2	Passive Logic 1	T_{rvp2}	96	128	163	t_{bdlc}
3	Active Logic 0	T_{rva1}	96	128	163	t_{bdlc}
4	Active Logic 1	T_{rva2}	32	64	95	t_{bdlc}
5	Start of Frame (SOF)	T_{rva3}	164	200	239	t_{bdlc}
6	End of Data (EOD)	T_{rvp3}	164	200	239	t_{bdlc}
7	End of Frame (EOF)	T_{rv4}	240	280	299	t_{bdlc}
8	Inter-Frame Separator (IFS)	T_{rv5}	300	---	---	t_{bdlc}
9	Break Signal (BREAK)	T_{rv6}	240	---	---	t_{bdlc}

NOTE:
 The receiver symbol timing boundaries are subject to an uncertainty of $1 t_{bdlc}$ due to sampling considerations.

Table 111 BDLC Receiver VPW Symbol Timing for Binary Frequencies

Number	Characteristic	Symbol ¹	Min	Typ	Max	Unit
1	Passive Logic 0	T_{rvp1}	34	67	100	t_{bdlc}
2	Passive Logic 1	T_{rvp2}	101	134	171	t_{bdlc}
3	Active Logic 0	T_{rva1}	101	134	171	t_{bdlc}
4	Active Logic 1	T_{rva2}	34	67	100	t_{bdlc}
5	Start of Frame (SOF)	T_{rva3}	172	210	251	t_{bdlc}
6	End of Data (EOD)	T_{rvp3}	172	210	251	t_{bdlc}
7	End of Frame (EOF)	T_{rv4}	252	293	314	t_{bdlc}
8	Inter-Frame Separator (IFS)	T_{rv5}	315	---	---	t_{bdlc}
9	Break Signal (BREAK)	T_{rv6}	252	---	---	t_{bdlc}

NOTE:

1. The receiver symbol timing boundaries are subject to an uncertainty of 1 t_{bdlc} due to sampling considerations.

Table 112 BDLC Receiver VPW 4X Symbol Timing for Integer Frequencies

Number	Characteristic	Symbol ¹	Min	Typ	Max	Unit
1	Passive Logic 0	T_{rvp1}	8	16	23	t_{bdlc}
2	Passive Logic 1	T_{rvp2}	24	32	40	t_{bdlc}
3	Active Logic 0	T_{rva1}	24	32	40	t_{bdlc}
4	Active Logic 1	T_{rva2}	8	16	23	t_{bdlc}
5	Start of Frame (SOF)	T_{rva3}	41	50	59	t_{bdlc}
6	End of Data (EOD)	T_{rvp3}	41	50	59	t_{bdlc}

Table 112 BDLC Receiver VPW 4X Symbol Timing for Integer Frequencies

Number	Characteristic	Symbol ¹	Min	Typ	Max	Unit
7	End of Frame (EOF)	T_{rv4}	60	70	74	t_{bdlc}
8	Inter-Frame Separator (IFS)	T_{rv5}	75	---	---	t_{bdlc}
9	Break Signal (BREAK)	T_{rv6}	60	---	---	t_{bdlc}

NOTE:

1. The receiver symbol timing boundaries are subject to an uncertainty of $1 t_{bdlc}$ due to sampling considerations.

Table 113 BDLC Receiver VPW 4X Symbol Timing for Binary Frequencies

Number	Characteristic	Symbol ¹	Min	Typ	Max	Unit
1	Passive Logic 0	T_{rvp1}	9	17	25	t_{bdlc}
2	Passive Logic 1	T_{rvp2}	26	34	42	t_{bdlc}
3	Active Logic 0	T_{rva1}	26	34	42	t_{bdlc}
4	Active Logic 1	T_{rva2}	9	17	25	t_{bdlc}
5	Start of Frame (SOF)	T_{rva3}	43	53	62	t_{bdlc}
6	End of Data (EOD)	T_{rvp3}	43	53	62	t_{bdlc}
7	End of Frame (EOF)	T_{rv4}	63	74	78	t_{bdlc}
8	Inter-Frame Separator (IFS)	T_{rv5}	79	---	---	t_{bdlc}
9	Break Signal (BREAK)	T_{rv6}	63	---	---	t_{bdlc}

NOTE:

1. The receiver symbol timing boundaries are subject to an uncertainty of $1 t_{bdlc}$ due to sampling considerations.

The min and max symbol limits shown in the following sections ([Invalid Passive Bit to Valid BREAK Symbol](#)) and figures ([Figure 119](#) – [Figure 122](#)) refer to the values listed in [Tables 108](#) through [113](#).

Byte Data Link

Invalid Passive Bit If the passive to active transition beginning the next data bit or symbol occurs between the active to passive transition beginning the current data bit or symbol and $T_{rvp1(\text{Min})}$, the current bit would be invalid. See [Figure 119\(1\)](#).

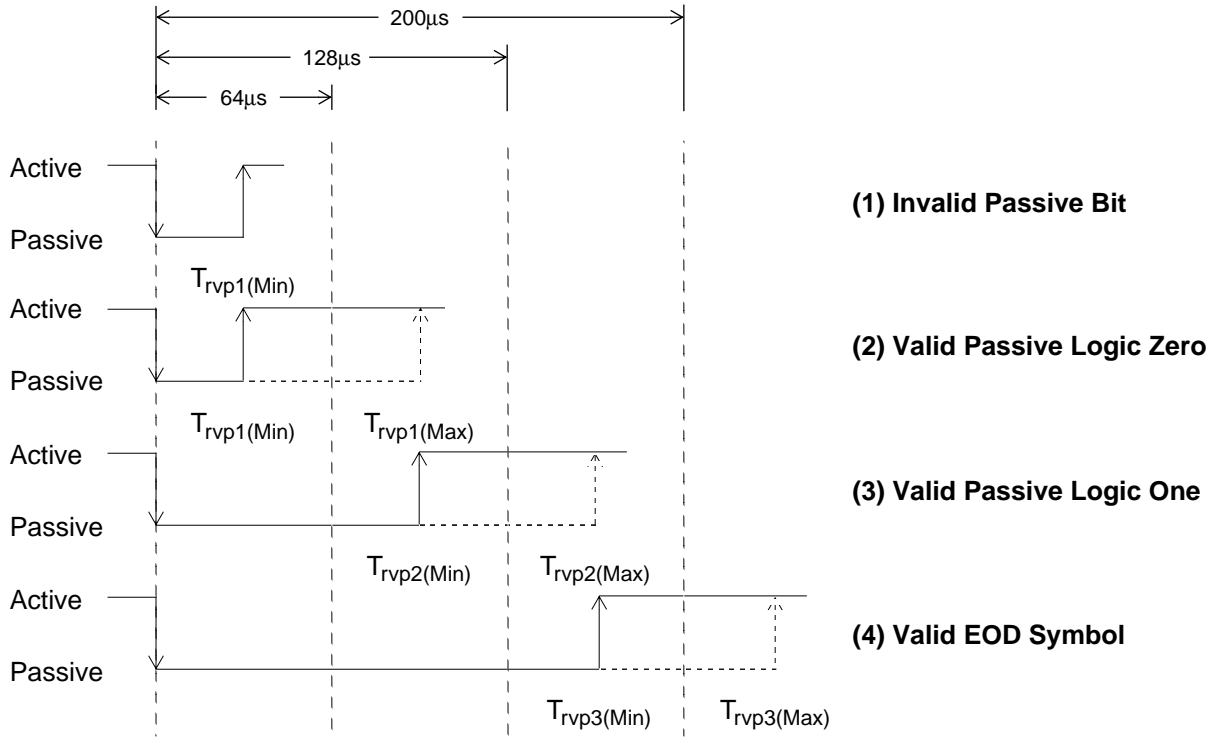

Figure 119 J1850 VPW Passive Symbols

Valid Passive Logic Zero If the passive to active transition beginning the next data bit or symbol occurs between $T_{rvp1(\text{Min})}$ and $T_{rvp1(\text{Max})}$, the current bit would be considered a logic zero. See [Figure 119\(2\)](#).

Valid Passive Logic One If the passive to active transition beginning the next data bit or symbol occurs between $T_{rvp2(\text{Min})}$ and $T_{rvp2(\text{Max})}$, the current bit would be considered a logic one. See [Figure 119\(3\)](#).

Valid EOD Symbol

If the passive to active transition beginning the next data bit or symbol occurs between $T_{rvp3(\text{Min})}$ and $T_{rvp3(\text{Max})}$, the current symbol would be considered a valid EOD symbol. See [Figure 119\(4\)](#).

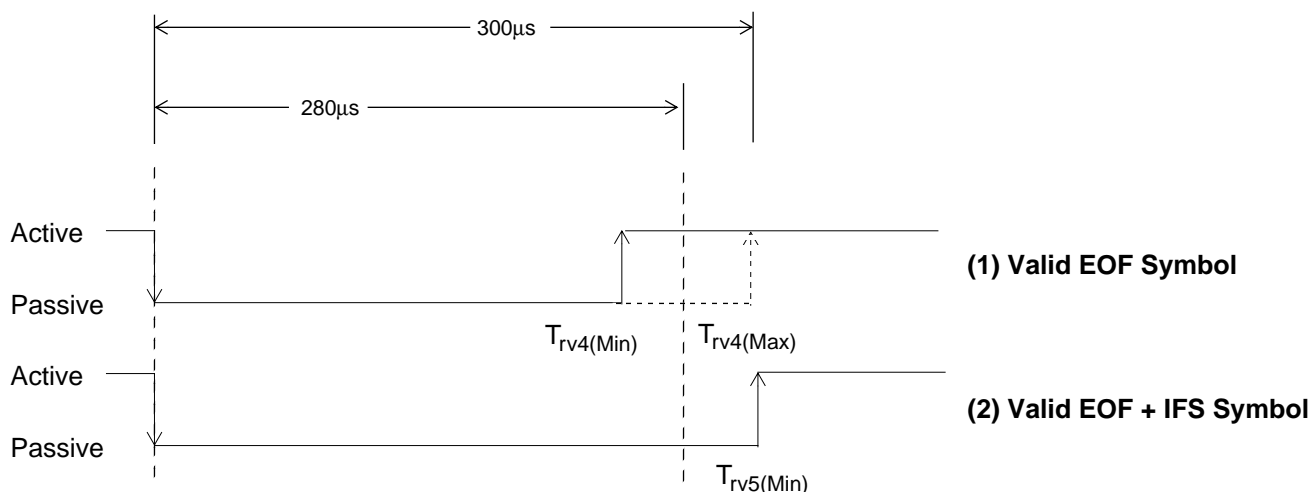

Figure 120 J1850 VPW EOF and IFS Symbols

Valid EOF & IFS Symbol

In [Figure 120\(1\)](#), if the passive to active transition beginning the SOF symbol of the next message occurs between $T_{rv4(\text{Min})}$ and $T_{rv4(\text{Max})}$, the current symbol will be considered a valid EOF symbol.

If the passive to active transition beginning the SOF symbol of the next message occurs after $T_{rv5(\text{Min})}$, the current symbol will be considered a valid EOF symbol followed by a valid IFS symbol. See [Figure 120\(2\)](#). All nodes must wait until a valid IFS symbol time has expired before beginning transmission. However, due to variations in clock frequencies and bus loading, some nodes may recognize a valid IFS symbol before others, and immediately begin transmitting. Therefore, anytime a node waiting to transmit detects a passive to active transition once a valid EOF has been detected, it should immediately begin transmission, initiating the arbitration process.

Idle Bus

If the passive to active transition beginning the SOF symbol of the next message does not occur before $T_{tv5(\text{Min})}$, the bus is considered to be idle, and any node wishing to transmit a message may do so immediately.

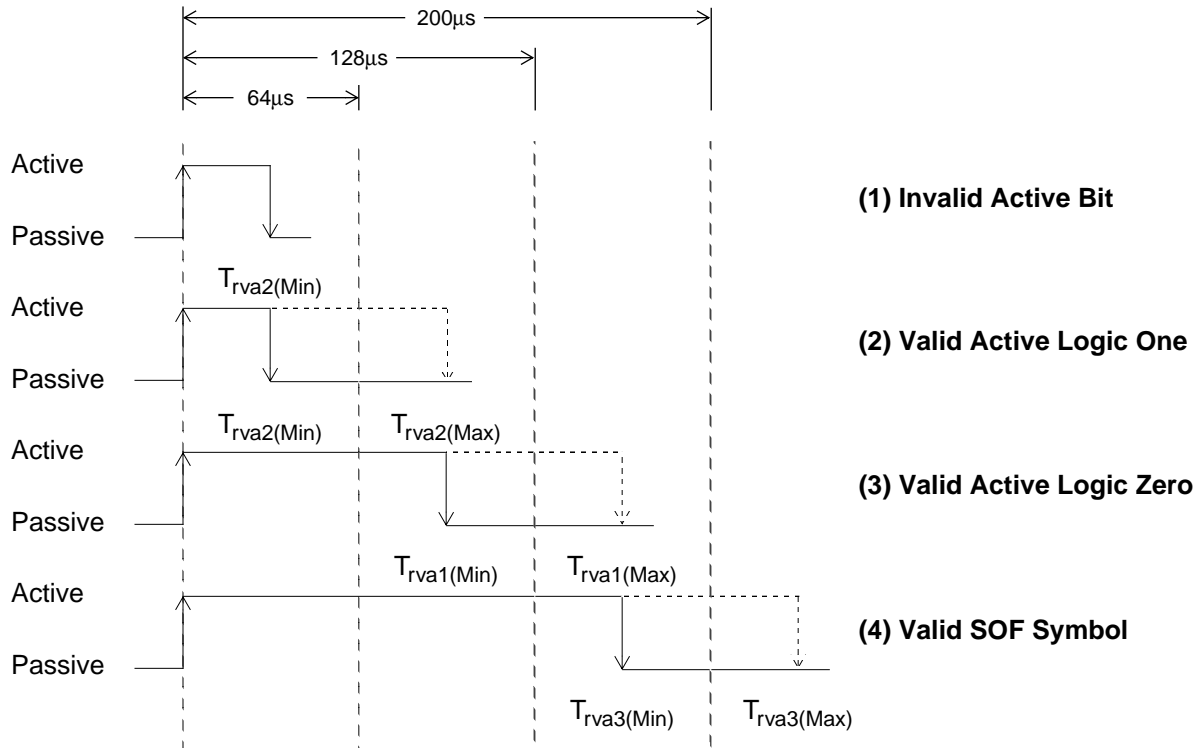

Figure 121 J1850 VPW Active Symbols

Invalid Active Bit If the active to passive transition beginning the next data bit or symbol occurs between the passive to active transition beginning the current data bit or symbol and $T_{rva2(Min)}$, the current bit would be invalid. See [Figure 121\(1\)](#).

Valid Active Logic One If the active to passive transition beginning the next data bit or symbol occurs between $T_{rva2(Min)}$ and $T_{rva2(Max)}$, the current bit would be considered a logic one. See [Figure 121\(2\)](#).

Valid Active Logic Zero If the active to passive transition beginning the next data bit or symbol occurs between $T_{rva1(Min)}$ and $T_{rva1(Max)}$, the current bit would be considered a logic zero. See [Figure 121\(3\)](#).

Valid SOF Symbol If the active to passive transition beginning the next data bit or symbol occurs between $T_{rva3(Min)}$ and $T_{rva3(Max)}$, the current symbol would be considered a valid SOF symbol. See [Figure 121\(4\)](#).

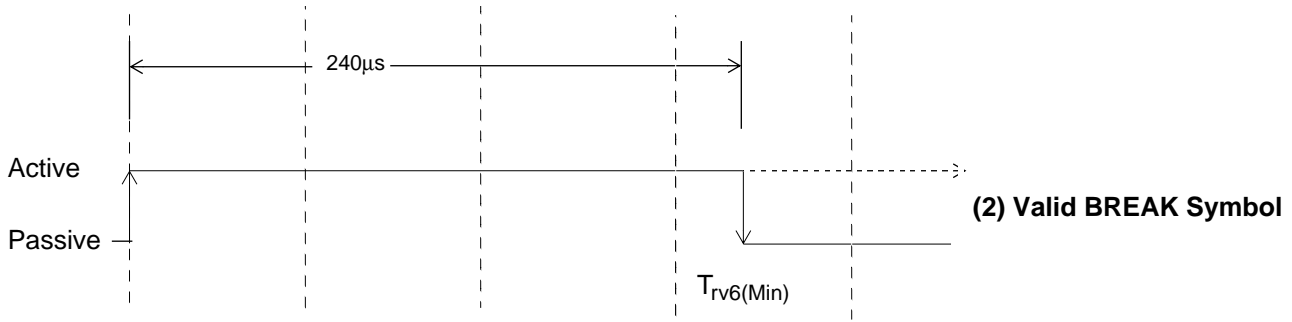

Figure 122 J1850 VPW BREAK Symbol

Valid BREAK Symbol

If the next active to passive transition does not occur until after $T_{rv6(Min)}$, the current symbol will be considered a valid BREAK symbol. A BREAK symbol should be followed by a SOF symbol beginning the next message to be transmitted onto the J1850 bus. See [Figure 122](#).

Message Arbitration

Message arbitration on the J1850 bus is accomplished in a non-destructive manner, allowing the message with the highest priority to be transmitted, while any transmitters which lose arbitration simply stop transmitting and wait for an idle bus to begin transmitting again.

If the BDLC wishes to transmit onto the J1850 bus, but detects that another message is in progress, it automatically waits until the bus is idle. However, if multiple nodes begin to transmit in the same synchronization window, message arbitration will occur beginning with the first bit after the SOF symbol and continue with each bit thereafter.

The VPW symbols and J1850 bus electrical characteristics are carefully chosen so that a logic zero (active or passive type) will always dominate over a logic one (active or passive type) simultaneously transmitted. Hence logic zeroes are said to be 'dominant' and logic ones are said to be 'recessive'.

Whenever a node transmits a recessive bit and detects a dominant bit, it loses arbitration, and immediately stops transmitting. This is known as 'bitwise arbitration'. The loss of arbitration flag (in DLCBSVR) is set when arbitration is lost. If the interrupt enable bit (IE in DLCBCR1) is set, an interrupt request from the BDLC is generated. Reading the DLCBSVR register will clear this flag.

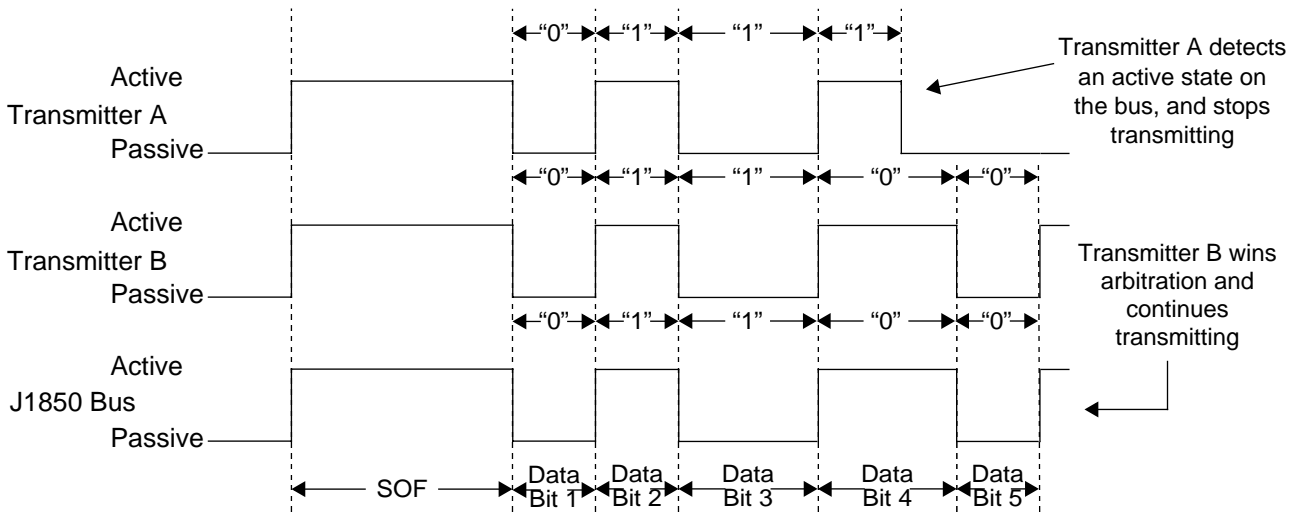

Figure 123 J1850 VPW Bitwise Arbitrations

During arbitration, or even throughout the transmitting message, when an opposite bit is detected, transmission is immediately stopped unless it occurs on the 8th bit of a byte. In this case the BDLC will automatically append up to two extra 1 bits and then stop transmitting. These two extra bits will be arbitrated normally and thus will not interfere with another message. The second 1 bit will not be sent if the first loses arbitration. If the BDLC has lost arbitration to another valid message then the two extra ones will not corrupt the current message. However, if the BDLC has lost arbitration due to noise on the bus, then the two extra ones will ensure that the current message will be detected and ignored as a noise-corrupted message.

Since a “0” dominates a “1”, the message with the lowest value will have the highest priority, and will always win arbitration, i.e. a message with priority 000 will win arbitration over a message with priority 011. This method of arbitration will work no matter how many bits of priority encoding are contained in the message.

Protocol Handler

The Protocol Handler is responsible for framing, collision detection, arbitration, CRC generation/checking, and error detection. The Protocol Handler conforms to SAE J1850 – Class B Data Communications Network Interface.

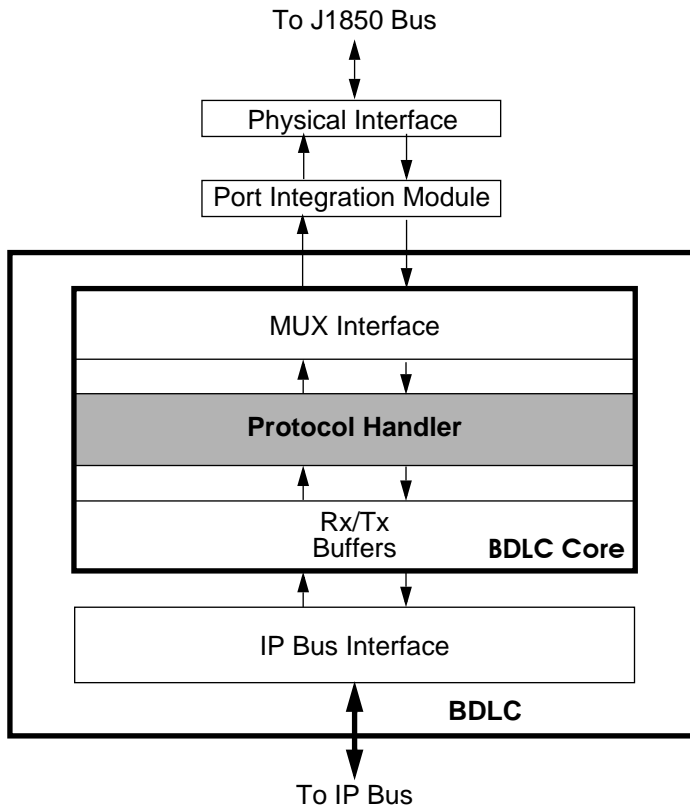

Figure 124 BDLC Block Diagram - Protocol Handler

Protocol Architecture

The Protocol Handler contains the State Machine, Rx Shadow Register, Tx Shadow Register, Rx Shift Register, Tx Shift Register, and Loopback Multiplexer as shown in [Figure 125](#). Each block will now be described in more detail.

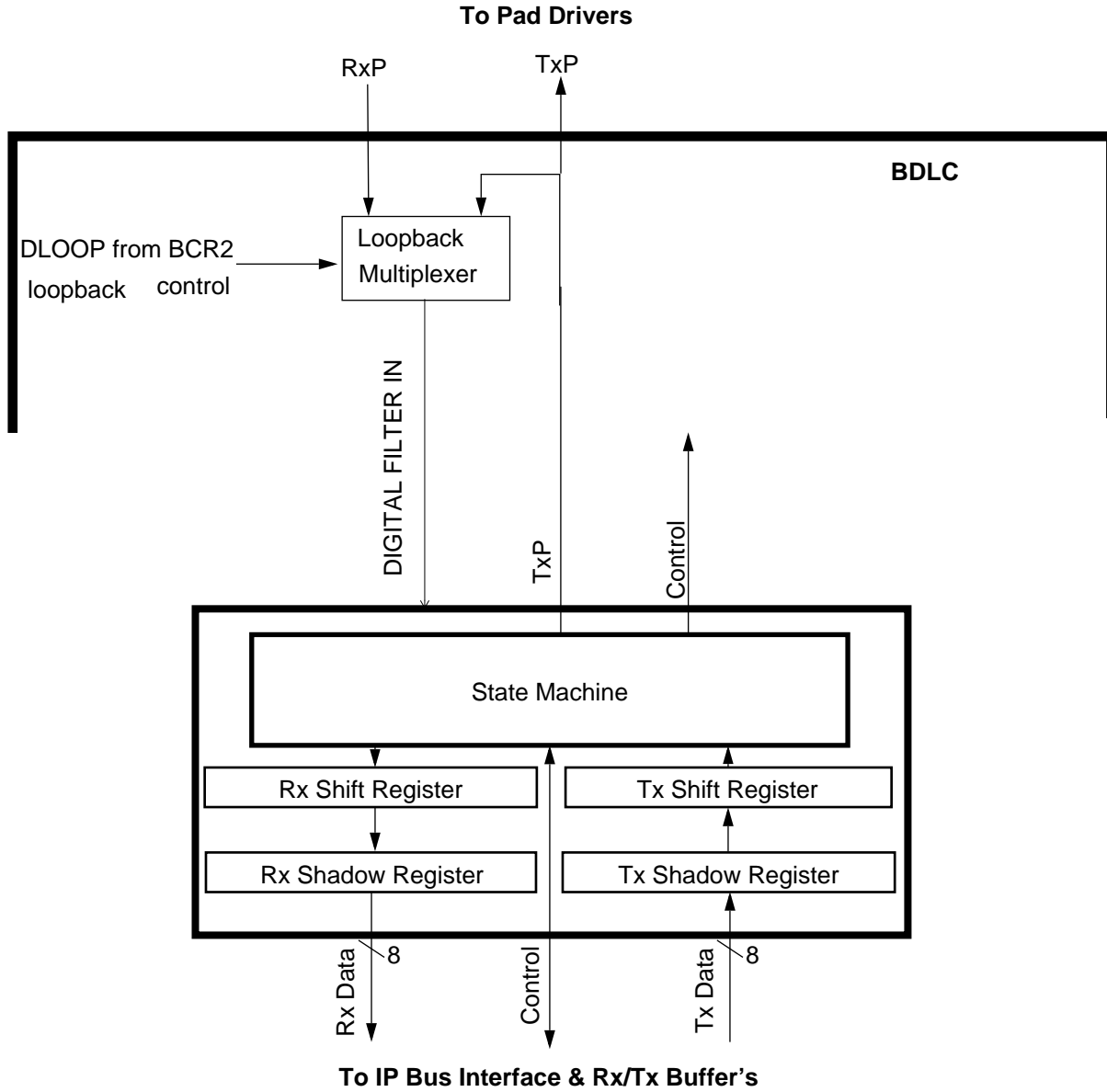

Figure 125 BDLC Protocol Handler Outline

Rx & Tx Shift Registers

The Rx Shift Register gathers received serial data bits from the J1850 bus and makes them available in parallel form to the Rx Shadow Register. The Tx Shift Register takes data, in parallel form, from the Tx Shadow Register and presents it serially to the State Machine so that it can be transmitted onto the J1850 bus.

<i>Rx & Tx Shadow Registers</i>	<p>Immediately after the Rx Shift Register has completed shifting in a byte of data, this data is transferred to the Rx Shadow Register and RDRF or RXIFR is set and interrupt is generated if the interrupt enable bit (IE) in BCR1 is set. After the transfer takes place, this new data byte in the Rx Shadow Register is available to the IP Bus interface, and the Rx Shift Register is ready to shift in the next byte of data. Data in Rx Shadow Register must be retrieved by the CPU before it is overwritten by new data from the Rx Shift Register.</p> <p>Once the Tx Shift Register has completed its shifting operation for the current byte, the data byte in the Tx Shadow Register is loaded into the Tx Shift Register. After this transfer takes place, the Tx Shadow Register is ready to accept new data from the IP Bus.</p>
<i>Digital Loopback Multiplexer</i>	<p>The Digital Loopback Multiplexer connects the input of the receive digital filter (See Figure 125) to either the transmit signal out to the pad (TxP) or the receive signal from the pad (RxP), depending on the state of the DLOOP bit in DLCBCR2 register.</p>
<i>State Machine</i>	<p>All of the functions associated with performing the protocol are executed or controlled by the State Machine. The State Machine is responsible for framing, collision detection, arbitration, CRC generation/checking, and error detection. The following sections describe the BDLC's actions in a variety of situations.</p>
<i>4X Mode</i>	<p>The BDLC can exist on the same J1850 bus as modules which use a special 4X (41.6 kbps) mode of J1850 VPW operation. The BDLC cannot transmit in 4X mode, but can receive messages in 4X mode, if the RX4X bit is set in BCR2 register. If the RX4X bit is not set in the BCR2 register, any 4X message on the J1850 bus is treated as noise by the BDLC and is ignored. Likewise, 4X messages transmitted on the SAE J1850 bus when the BDLC is in normal mode will be interpreted as noise on the network by the BDLC.</p>
<i>Receiving a Message in Block Mode</i>	<p>Although not a part of the SAE J1850 protocol, the BDLC does allow for a special "Block Mode" of operation of the receiver. As far as the BDLC is concerned, a Block Mode message is simply a long J1850 frame that</p>

contains an indefinite number of data bytes. All of the other features of the frame remain the same, including the SOF, CRC, and EOD symbols.

Another node wishing to send a Block Mode transmission must first inform all other nodes on the network that this is about to happen. This is usually accomplished by sending a special predefined message.

Transmitting a Message in Block Mode

A Block mode message is transmitted inherently by simply loading the bytes one by one into the BDR register until the message is complete. The programmer should wait until the TDRE flag is set prior to writing a new byte of data into the BDR register. The BDLC does not contain any predefined maximum J1850 message length requirement.

J1850 Bus Errors

The BDLC detects several types of transmit and receive errors which can occur during the transmission of a message onto the J1850 bus.

Transmission Error

If the BDLC is transmitting a message and the message received contains a symbol error, a framing error, a bus fault, a BREAK symbol, or a logic '1' symbol when a logic "0" is being transmitted, this constitutes a transmission error. Receiving a logic '0' symbol when transmitting a logic '1' is considered a loss of arbitration condition (See section [Message Arbitration](#)) and not a transmission error. When a transmission error is detected the BDLC will immediately cease transmitting. Further transmission or reception will be disabled until a valid EOF symbol is detected on the J1850 bus. The error condition is reflected by setting the symbol invalid or out of range flag in the DLCBSVR register. If the interrupt enable bit (IE in DLCBCR1) is set, an interrupt request from the BDLC is generated. Reading the DLCBSVR register will clear this flag.

CRC Error

A cyclical redundancy check (CRC) error is detected when the data bytes and CRC byte of a received message are processed, and the CRC calculation result is not equal to \$C4. The CRC code should detect any single and 2 bit errors, as well as all 8 bit burst errors, and almost all other types of errors. The CRC error flag (in DLCBSVR) is set when a CRC error is detected. If the interrupt enable bit (IE in DLCBCR1) is set, an interrupt request from the BDLC is generated. Reading the DLCBSVR register will clear this flag.

Symbol Error

A symbol error is detected when an abnormal (invalid) symbol is detected in a message being received from the J1850 bus. See sections [Invalid Passive Bit](#) and [Invalid Active Bit](#) which define invalid symbols. The symbol invalid or out of range flag (in DLCBSVR) is set when a symbol error is detected. If the interrupt enable bit (IE in DLCBCR1) is set, an interrupt request from the BDLC is generated. Reading the DLCBSVR register will clear this flag.

Framing Error

A framing error is detected when a received symbol occurs in an inappropriate location in the message frame. The following situations result in framing errors:

- An active logic “0” or logic “1” received as the first symbol of the frame.
- An SOF symbol received in any location other than the first symbol of a frame. Erroneous locations include: Within the data portion of a message or IFR; Immediately following the EOD in a message or IFR.
- An EOD symbol received on a non-byte boundary in a message or IFR.
- An active logic “0” or logic “1” received immediately following the EOD at the end of an IFR.

The symbol invalid or out of range flag (in DLCBSVR) is set when a framing error is detected. If the interrupt enable bit (IE in DLCBCR1) is set, an interrupt request from the BDLC is generated. Reading the DLCBSVR register will clear this flag.

Bus Fault

If a bus fault occurs, the response of the BDLC will depend upon the type of bus fault.

If the bus is shorted to V_{DD} , the BDLC will wait for the bus to fall to a passive state before it will attempt to transmit a message. As long as the short remains, the BDLC will never attempt to transmit a message onto the J1850 bus.

If the bus is shorted to ground, the BDLC will see an idle bus, begin to transmit the message, and then detect a transmission error, since the

short to ground would not allow the bus to be driven to the active (dominant) state. The BDLC will wait for assertion of the receive pin for (64 - analog round trip delay) t_{bdlc} cycles, after assertion of the transmit pin, before detecting the error. If the transmission is an IFR, the BDLC will wait for (280 - analog round trip delay) t_{bdlc} cycles before detecting an error. The “analog round trip delay” is determined by the value stored in the DLCBARD register. The BDLC will set the symbol invalid or out of range flag (in DLCBSVR), abort that transmission and wait for the next IP Bus command to transmit. In this case, the transmitter does not have to wait for an EOF symbol to be received to be enabled. If the interrupt enable bit (IE in DLCBCR1) is set, an interrupt request from the BDLC is generated. Reading the DLCBSVR register will clear this flag.

In any case, if the bus fault is temporary, as soon as the fault is cleared, the BDLC will resume normal operation. If the bus fault is permanent, it may result in permanent loss of communication on the J1850 bus.

BREAK – Break

Any BDLC transmitting at the time a BREAK is detected will treat the BREAK as if a transmission error had occurred, and halt transmission.

If while receiving a message the BDLC detects a BREAK symbol, it will treat the BREAK as a reception error.

If a BREAK symbol is received while the BDLC is transmitting or receiving, the symbol invalid or out of range flag (in DLCBSVR) is set. Further transmission/reception will be disabled until the J1850 bus returns to the passive state and a valid EOF symbol is detected on the J1850 bus. If the interrupt enable bit (IE in DLCBCR1) is set, an interrupt request from the BDLC is generated. Reading the DLCBSVR register will clear this flag.

The BDLC cannot transmit a BREAK symbol. It can only receive a BREAK symbol from the J1850 bus.

Bus Error Summary

The possible J1850 bus errors and the actions taken by the BDLC are summarized in [Table 114](#).

Table 114 BDLC J1850 Error Summary

Error Condition	BDLC Function
Transmission Error	BDLC will immediately cease transmitting. Further transmission and reception will be disabled until a valid EOF symbol is detected. The symbol invalid or out of range flag will be set and interrupt generated if enabled.
Cyclical Redundancy Check (CRC) Error	CRC error flag set and interrupt generated if enabled.
Symbol Error	The symbol invalid or out of range flag will be set and interrupt generated if enabled. Transmission and reception will be disabled until a valid EOF symbol is detected.
Framing Error	The symbol invalid or out of range flag will be set and interrupt generated if enabled. Transmission and reception will be disabled until a valid EOF symbol is detected.
Bus short to V_{DD} .	The BDLC will not transmit until short is corrected and a valid EOF is detected. Depending upon when short occurs and is corrected, this error condition may set the symbol invalid or out of range, crc error, or loss of arbitration flags.
Bus short to GND.	Short will be seen as an idle bus by BDLC. If a transmission attempt is made before short is corrected, the symbol invalid or out of range flag will be set and interrupt generated if enabled. Another transmission can be initiated as soon as short is corrected.
BREAK symbol reception	If doing so, the BDLC will immediately cease transmitting. Symbol invalid or out of range flag set and interrupt generated if enabled. Transmission and reception will be disabled until a valid EOF symbol is detected.

IP Bus Interface

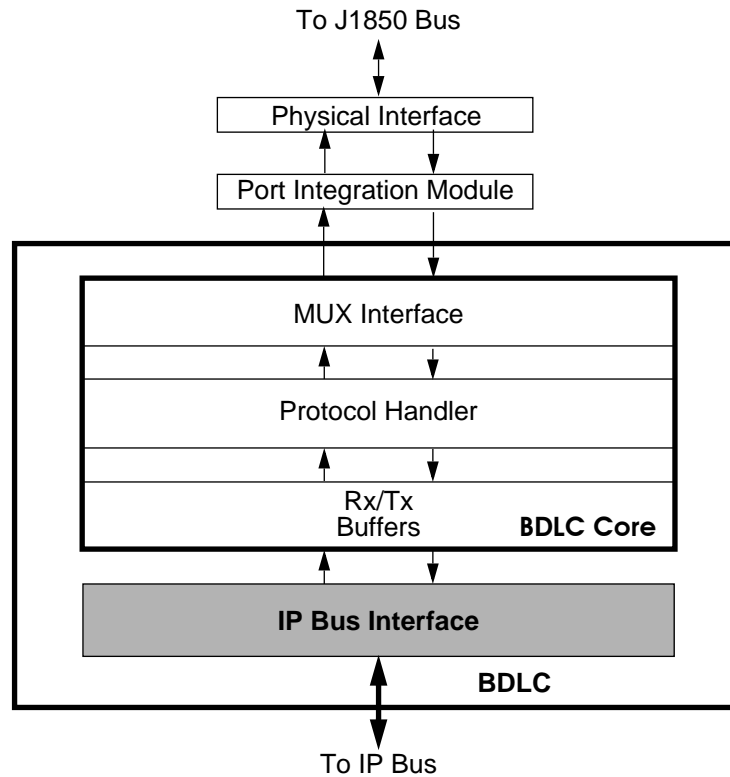

Figure 126 BDLC Block Diagram - IP Bus Interface

The IP Bus Interface provides the interface between the IP Bus and the rest of the BDLC. The address space of the BDLC is continuous, consisting of 8 bytes starting at the base address. The base address of the module is hardware programmable as defined by the IP Bus Specification.

The register decode map is fixed and begins at the first address of the Module Base Address. [Table 107](#) in [Register Map](#) shows the registers associated with the BDLC module and their relative offset from the base address.

Register Descriptions

NOTE: All bits of all registers in this module are completely synchronous to internal clocks during a register read.

BDLC Control Register 1 (DLCBCR1)

This register is used to configure and control the BDLC.

Address Offset: \$0000

	Bit 7	6	5	4	3	2	1	Bit 0
Read:	IMSG	CLKS	0	0	0	0	IE	WCM
Write:								
Reset:	1	1	0	0	0	0	0	0

= Unimplemented

READ: any time

WRITE: IMMSG, IE, and WCM any time.

CLKS write once in normal and emulation modes.

CLKS bit has modified functionality in special test mode.

Writes to unimplemented bits 5-2 are ignored.

IMMSG — Ignore Message (Bit 7)

This bit allows the CPU to ignore messages by disabling updates of the DLCBSVR register until a new Start of Frame (SOF) or a BREAK symbol is detected. BDLC transmitter and receiver operation are unaffected by the state of the IMMSG bit.

1 = Disable DLCBSVR Updates. When set, all BDLC interrupt sources (exceptions are described below) will be prevented from updating DLCBSVR status bits. Setting IMMSG does not clear pending interrupt flags, the behavior of which will still be as described in [BDLC State Vector Register \(DLCBSVR\)](#). If this bit is set while the BDLC is receiving or transmitting a message, state vector register updates will be inhibited for the rest of the message.

0 = Enable DLCBSVR Updates. This bit is automatically cleared by the reception of a SOF symbol or a BREAK symbol. It will then allow updates of the state vector register to occur.

There are two situations in which interrupts will not be masked by the IMMSG bit: when a wakeup interrupt occurs; and when a receiver error occurs which causes a byte pending transmission to be flushed from the transmit shadow register. See [BDLC Data Register \(DLCBDR\)](#) for a description of the conditions which cause a pending transmission to be flushed.

CLKS — Clock Select (Bit 6)

The nominal BDLC operating frequency (mux interface clock frequency - f_{bdlc}) **must** always be 1.048576 MHz or 1 MHz in order for J1850 bus communications to take place properly. The CLKS register bit is provided to allow the user to indicate to the BDLC which frequency (1.048576 MHz or 1 MHz) is used so that each symbol time can be automatically adjusted.

The CLKS bit is a write once bit. All writes to this bit will be ignored after the first one.

1 = Binary frequency (1.048576 MHz) is used for f_{bdlc} .

0 = Integer frequency (1 MHz) is used. for f_{bdlc}

[J1850 VPW Valid/Invalid Bits & Symbols](#) describes the transmitter and receiver VPW symbol timing for integer and binary frequencies.

IE — Interrupt Enable (Bit 1)

This bit determines whether the BDLC will generate CPU interrupt requests. It does not affect CPU interrupt requests when exiting the BDLC Stop or Wait modes. Interrupt requests will be maintained until all of the interrupt request sources are cleared, by performing the specified actions upon the BDLC's registers. Interrupts that were pending at the time that this bit is cleared may be lost.

1 = Enable interrupt requests from BDLC

0 = Disable interrupt requests from BDLC

If the programmer does not wish to use the interrupt capability of the BDLC, the BDLC State Vector Register (DLCBSVR) can be polled periodically by the programmer to determine BDLC states. Refer to [BDLC State Vector Register \(DLCBSVR\)](#) for a description of DLCBSVR register and how to clear interrupt requests.

WCM — Wait Clock Mode (Bit 0)

This bit determines how the BDLC responds when the CPU enters WAIT mode. As described in [Modes of Operation](#), the BDLC can respond by either entering BDLC_STOP mode, where all internal clocks are stopped, or entering BDLC_WAIT mode where internal clocks are allowed to run.

- 1 = Stop BDLC internal clocks during CPU wait mode (BDLC_STOP)
- 0 = Run BDLC internal clocks during CPU wait mode (BDLC_WAIT)

BDLC State Vector Register (DLCBSVR)

This register is provided to substantially decrease the CPU overhead associated with servicing interrupts while under operation of a MUX protocol. It provides a index offset that is directly related to the BDLC's current state, which can be used with a user supplied jump table to rapidly enter an interrupt service routine. This eliminates the need for the user to maintain a duplicate state machine in software.

Address Offset: \$0001

	Bit 7	6	5	4	3	2	1	Bit 0
Read:	0	0	I3	I2	I1	I0	0	0
Write:								
Reset:	0	0	0	0	0	0	0	0

= Unimplemented

READ: any time

WRITE: ignored

I[3:0] — Interrupt State Vector (Bits 5–2)

These bits indicate the source of the interrupt request that is currently pending. The encoding of these bits follows

Table 115 Interrupt Sources

BSVR	I3	I2	I1	I0	Interrupt Source	Priority
\$00	0	0	0	0	No Interrupts Pending	0 (lowest)
\$04	0	0	0	1	Received EOF	1
\$08	0	0	1	0	Received IFR byte (RXIFR)	2
\$0C	0	0	1	1	Rx data register full (RDRF)	3
\$10	0	1	0	0	Tx data register empty (TDRE)	4
\$14	0	1	0	1	Loss of arbitration	5
\$18	0	1	1	0	CRC error	6
\$1C	0	1	1	1	Symbol invalid or out of range	7
\$20	1	0	0	0	Wakeup	8 (highest)

Bits I0, I1, I2, and I3 are cleared by a read of the DLCBSVR register except when the BDLC Data Register needs servicing (RDRF, RXIFR, or TDRE conditions). RXIFR and RDRF can only be cleared by a read of the BSVR register followed by a read of DLCBDR. TDRE can either be cleared by a read of the DLCBSVR register followed by a write to the DLCBDR register, or by setting the TEOB bit in BCR2. TDRE can also be cleared by the setting of the Loss of Arbitration, CRC Error, or Invalid Symbol flags.

Upon receiving a BDLC interrupt, the user may read the value within the DLCBSVR, transferring it to the CPU's Index Register. The value may then be used to index into a 'jump table', with entries 4 bytes apart, to quickly enter the appropriate service routine. For example:

```

SERVICELDX    BSVR      Fetch State Vector Number
                JMP      JMPTAB,X Enter service routine,
                *                (must end in an 'RTI')
                *
JMPTAB JMP      SERVE0   Service condition #0
          NOP
          JMP      SERVE1   Service condition #1
          NOP
          JMP      SERVE2   Service condition #2
          NOP
          ...      ...      ...
    
```

```
JMP    SERVE8  Service condition #8
END
```

Note that the NOPs are just used to align the JMPs onto 4-byte boundaries so that the value in the DLCBSVR may be used intact. Each of the service routines must end with an 'RTI' instruction to guarantee correct continued operation of the device. Note also that the first entry can be omitted since it corresponds to no interrupt occurring.

The service routines should clear all of the sources that are causing the pending interrupts. Note that the clearing of a high priority interrupt may still leave a lower priority interrupt pending, in which case bits I0, I1 and I2 of the DLCBSVR will then reflect the source of the remaining interrupt request.

If fewer states are used, or if a different software approach is taken, the jump table may be made smaller or omitted altogether.

BDLC Control Register 2 (DLCBCR2)

This register controls transmitter operations of the BDLC.

Address Offset: \$0002

	Bit 7	6	5	4	3	2	1	Bit 0
Read:	SMRST	DLOOP	RX4XE	NBFS	TEOD	TSIFR	TMIFR1	TMIFR0
Write:								
Reset:	0	1	0	0	0	0	0	0

READ: any time

WRITE: any time

SMRST — State Machine Reset (Bit 7)

The programmer can use this bit to reset the BDLC state machines to an initial state after the user put the off-chip analog transceiver in loop back mode.

- 1 = Setting SMRST arms the state machine reset generation logic. Setting SMRST does not affect BDLC behavior in any way.

0 = Clearing SMRST after it has been set will cause the generation of a state machine reset. After SMRST is cleared, the BDLC requires the bus to be idle for a minimum of an End of Frame symbol (EOF) time before allowing the reception of a message. The BDLC requires the bus to be idle for a minimum of an Inter-Frame Separator symbol (IFS) time before allowing any message to be transmitted.

DLOOP — Digital Loopback Mode (Bit 6)

This bit determines the source to which the input of the digital filter is connected and can be used to isolate bus fault conditions. If a fault condition has been detected on the bus, this control bit allows the programmer to disconnect the digital filter from input from the receive pin (RxP) and connect it to the transmit output to the pin (TxP). In this configuration, data sent from the transmit buffer should be reflected back into the receive buffer. If no faults exist in the digital block, the fault is in the physical interface block or elsewhere on the J1850 bus.

1 = When set, digital filter input is connected to the transmitter output. The BDLC is now in Digital Loopback Mode of operation. The transmit pin (TxP) is driven low and not driven by the transmitter output.

0 = When cleared, digital filter input is connected to receive pin (RxP) and the transmitter output is connected to the transmit pin (TxP). The BDLC is taken out of Digital Loopback Mode and can now drive and receive from the J1850 bus normally. After writing DLOOP to zero, the BDLC requires the bus to be idle for a minimum of an End of Frame symbol time before allowing a reception of a message. The BDLC requires the bus to be idle for a minimum of an Inter-Frame Separator symbol time before allowing any message to be transmitted.

NOTE: *The DLOOP bit is a fault condition aid and should never be altered after the DLCBDR is loaded for transmission. Changing DLOOP during a transmission may cause corrupted data to be transmitted onto the J1850 network.*

RX4XE — Receive 4X Enable (Bit 5)

This bit determines if the BDLC operates at normal transmit and receive speed (10.4 kbps) or receive only at 41.6 kbps. This feature is useful for fast download of data into a J1850 node for diagnostic or factory programming of the node.

1 = When set, the BDLC is put in 4X (41.6 kbps) receive only operation.

0 = When cleared, the BDLC transmits and receives at 10.4 kbps. Reception of a BREAK symbol automatically clears this bit and sets the symbol invalid or out of range flag (DLCBSVR = \$1C).

The effect of 4X receive operation on receive symbol timing boundaries is described in section [Transmit and Receive Symbol Timing Specifications](#). The RX4XE bit is not affected by entry or exit from BDLC stop or wait modes.

NBFS — Normalization Bit Format Select (Bit 4)

This bit controls the format of the Normalization Bit (NB). SAE J1850 strongly encourages the use of an active long, '0', for In-Frame Responses containing CRC and active short, '1', for In-Frame Responses without CRC.

1 = NB that is received or transmitted is a '0' when the response part of an In-Frame Response (IFR) ends with a CRC byte. NB that is received or transmitted is a '1' when the response part of an In-Frame Response (IFR) does not end with a CRC byte.

0 = NB that is received or transmitted is a '1' when the response part of an In-Frame Response (IFR) ends with a CRC byte. NB that is received or transmitted is a '0' when the response part of an In-Frame Response (IFR) does not end with a CRC byte.

TEOD — Transmit End of Data (Bit 3)

This bit is set by the programmer to indicate the end of a message being sent by the BDLC. It will append an 8-bit CRC after completing transmission of the current byte in the Tx Shift Register followed by the EOD symbol. If the transmit shadow register (refer to [Rx & Tx Shadow Registers](#) for a description of the transmit shadow register) is full when TEOD is set, the CRC byte and EOD will be transmitted after the current byte in the Tx Shift Register and the byte in the Tx

Shadow Register have been transmitted. Once TEOD is set, the transmit data register empty flag (TDRE) in the BDLC State Vector Register (DLCBSVR) is cleared to allow lower priority interrupts to occur. This bit is also used to end an IFR. Bits TSIFR, TMIFR1, and TMIFR0 determine whether a CRC byte is appended before EOD transmission for IFRs.

1 = Transmit EOD symbol.

0 = The TEOD bit will be automatically cleared after the first CRC bit is sent, or if an error or loss of arbitration is detected on the bus. When TEOD is used to end an IFR transmission, TEOD is cleared when the BDLC receives back a valid EOD symbol, or an error condition or loss of arbitration occurs.

TSIFR, TMIFR1, TMIFR0 — Transmit In-Frame Response Control (Bits 2-0)

These three bits control the type of In-Frame Response being sent. The programmer should not set more than one of these control bits to a one at any given time. However, if more than one of these three control bits are set to one, the priority encoding logic will force the internal register bits to a known value as shown in the following table. But, when these bits are read, they will be the same as written earlier. For instance, if “011” is written to TSIFR, TMIFR1, TMIFR0, then internally, they’ll be encoded as “010”. However, when these bits are later read back, it’ll still be “011”.

Table 116 Transmit In-Frame Response Control Bit Priority Encoding

Write			Read			Actual (internal register)		
TSIFR	TMIFR1	TMIFR0	TSIFR	TMIFR1	TMIFR0	TSIFR	TMIFR1	TMIFR0
0	0	0	0	0	0	0	0	0
1	X	X	1	X	X	1	0	0
0	1	X	0	1	X	0	1	0
0	0	1	0	0	1	0	0	1

The BDLC supports the In-frame Response (IFR) feature of J1850 by setting these bits correctly. The four types of J1850 IFR are shown in [Types of In-Frame Response](#). The purpose of the in-frame response modes is to allow single or multiple nodes to acknowledge receipt of the data by responding to a received message after they have seen the EOD symbol. For VPW modulation, the first bit of the IFR is always passive; therefore, an active normalization bit must be generated by the responder and sent prior to its ID/address byte. When there are multiple responders on the J1850 bus, only one normalization bit is sent which assists all other transmitting nodes to sync their responses.

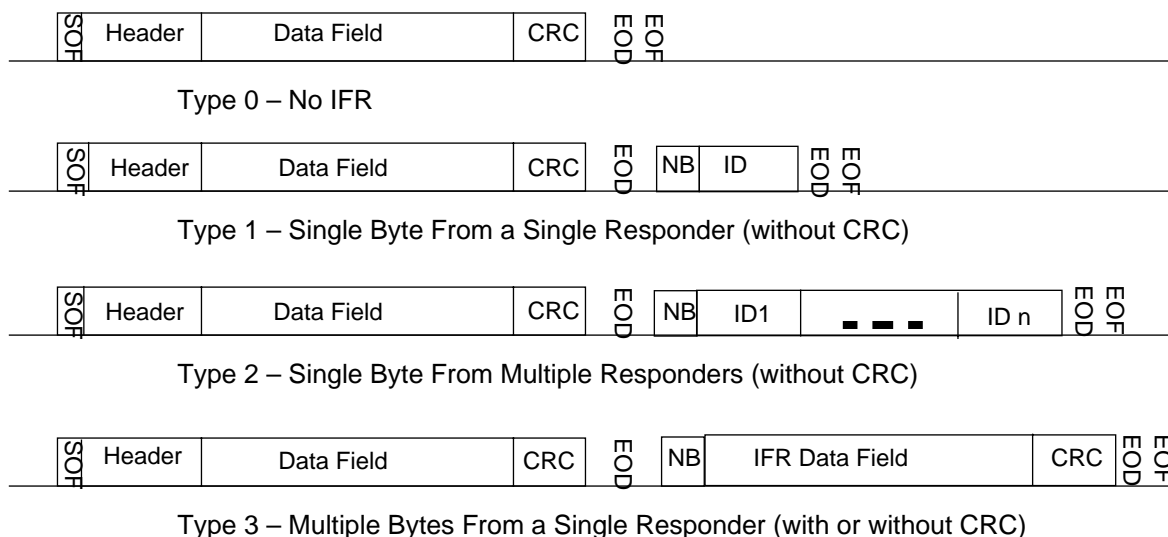

Figure 127 Types of In-Frame Response

TSIFR — Transmit Single Byte IFR with no CRC (Type 1 or 2)

This bit is used to request the BDLC to transmit the byte in the BDLC Data Register (DLCBDR) as a single byte IFR with no CRC. Typically, the byte transmitted is a unique identifier or address of the transmitting (responding) node.

- 1 = If this bit is set prior to a valid EOD being received with no CRC error, once the EOD symbol has been received the BDLC will attempt to transmit the appropriate normalization bit followed by the byte in the DLCBDR.

0 = The TSIFR bit will be automatically cleared once the EOD following one or more IFR bytes has been received or an error is detected on the bus.

The user must set the TSIFR bit before the EOF following the main part of the message frame is received, or no IFR transmit attempts will be made for the current message. If another node transmits an IFR to this message, the user must set the TSIFR bit before the normalization bit is received or no IFR transmit attempts will be made for the message. If another node does transmit a successful IFR or a reception error occurs, the TSIFR bit will be cleared. If not, the IFR will be transmitted after the EOD of the next received message.

If a loss of arbitration occurs when the BDLC attempts transmission, after the IFR byte winning arbitration completes transmission, the BDLC will again attempt to transmit the byte in the DLCBDR (with no normalization bit). The BDLC will continue transmission attempts until an error is detected on the bus, or TEOD is set by the CPU, or the BDLC transmission is successful.

NOTE: Setting the TEOD bit before transmission of the IFR byte will direct the BDLC to make only one attempt at transmitting the byte.

If loss of arbitration occurs in the last bit of the IFR byte, two additional '1' bits **will not** be sent out because the BDLC will attempt to retransmit the byte in the transmit shift register after the IFR byte winning arbitration completes transmission.

TMIFR1 — Transmit Multiple Byte IFR with CRC (Type 3)

This bit requests the BDLC to transmit the byte in the BDLC Data Register (DLCBDR) as the first byte of a multiple byte IFR with CRC or as a single byte IFR with CRC. Response IFR bytes are still subject to J1850 message length maximums.

1 = If this bit is set prior to a valid EOD being received with no CRC error, once the EOD symbol has been received the BDLC will attempt to transmit the appropriate normalization bit followed by IFR bytes. The programmer should set TEOD after the last IFR byte has been written into DLCBDR register. After TEOD has been set and the last IFR byte has been transmitted, the CRC byte is transmitted.

0 = The TMIFR1 bit will be automatically cleared once the BDLC has successfully transmitted the CRC byte and EOD symbol, by the detection of an error on the multiplex bus, a transmitter underrun, or loss of arbitration.

After the byte in the DLCBDR has been loaded into the transmit shift register, the TDRE flag will be set in the DLCBSVR register, similar to the main message transmit sequence. If the interrupt enable bit (IE in DLCBCR1) is set, an interrupt request from the BDLC is generated. The programmer should then load the next byte of the IFR into the DLCBDR for transmission. When the last byte of the IFR has been loaded into the DLCBDR, the programmer should set the TEOD bit in the BDLC control register 2 (DLCBCR2). This will instruct the BDLC to transmit a CRC byte once the byte in the DLCBDR is transmitted, and then transmit an EOD symbol, indicating the end of the IFR portion of the message frame.

However, if the programmer wishes to transmit a single byte followed by a CRC byte, the programmer should load the byte into the DLCBDR and then set the TMIFR1 bit before the EOD symbol has been received. Once the TDRE flag is set and interrupt occurs (if enabled), the programmer should then set the TEOD bit in DLCBCR2. This will result in the byte in the DLCBDR being the only byte transmitted before the IFR CRC byte.

The user must set the TMIFR1 bit before the EOF following the main part of the message frame is received, or no IFR transmit attempts will be made for the current message. If another node transmits an IFR to this message, the user must set the TMIFR1 bit before the normalization bit is received or no IFR transmit attempts will be made for the message. If another node does transmit a successful IFR or a reception error occurs, the TMIFR1 bit will be cleared. If not, the IFR will be transmitted after the EOD of the next received message.

If a transmitter underrun error occurs during transmission (caused by the programmer not writing another byte to the DLCBDR following the TDRE flag being set) the BDLC will automatically disable the transmitter after the byte currently in the shifter plus two extra 1-bits have been transmitted. The receiver will pick this up as a framing error and relay it in the State Vector Register as an invalid symbol error. The TMIFR1 bit will also be cleared.

If a loss of arbitration occurs when the BDLC is transmitting a multiple byte IFR with CRC, the BDLC will go to the loss of arbitration state, set the appropriate flag and cease transmission. The TMIFR1 bit will be cleared and no attempt will be made to retransmit the byte in the DLCBDR. If loss of arbitration occurs in the last bit of the IFR byte, two additional one bits (a passive long followed by an active short) **will** be sent out.

NOTE: *The extra logic 1s are an enhancement to the J1850 protocol which forces a byte boundary condition fault. This is helpful in preventing noise on the J1850 bus from corrupting a message.*

TMIFR0 — Transmit Multiple Byte IFR with no CRC (Type 3)

This bit is used to request the BDLC to transmit the byte in the BDLC Data Register (DLCBDR) as the first byte of a multiple byte IFR without CRC. Response IFR bytes are still subject to J1850 message length maximums.

1 = If this bit is set prior to a valid EOD being received with no CRC error, once the EOD symbol has been received the BDLC will attempt to transmit the appropriate normalization bit followed by IFR bytes. The programmer should set TEOD after the last IFR byte has been written into DLCBDR register. After TEOD has been set, the last IFR byte to be transmitted will be the last byte which was written into the DLCBDR register.

0 = The TMIFR0 bit will be automatically cleared once the BDLC has successfully transmitted the EOD symbol, by the detection of an error on the multiplex bus, a transmitter underrun, or loss of arbitration.

After the byte in the DLCBDR has been loaded into the transmit shift register, the TDRE flag will be set in the DLCBSVR register, similar to the main message transmit sequence. If the interrupt enable bit (IE in DLCBCR1) is set, an interrupt request from the BDLC is generated. The programmer should then load the next byte of the IFR into the DLCBDR for transmission. When the last byte of the IFR has been loaded into the DLCBDR, the programmer should set the TEOD bit in the DLCBCR2 register. This will instruct the BDLC to transmit an EOD symbol, indicating the end of the IFR portion of the message frame. The BDLC will not append a CRC.

However, if the programmer wishes to transmit a single byte, the programmer should load the byte into the DLCBDR and then set the TMIFR0 bit before the EOD symbol has been received. Once the TDRE flag is set and interrupt occurs (if enabled), the programmer should then set the TEOD bit in DLCBCR2. This will result in the byte in the DLCBDR being the only byte transmitted.

The user must set the TMIFR0 bit before the EOF following the main part of the message frame is received, or no IFR transmit attempts will be made for the current message. If another node transmits an IFR to this message, the user must set the TMIFR0 bit before the normalization bit is received or no IFR transmit attempts will be made for the message. If another node does transmit a successful IFR or a reception error occurs, the TMIFR0 bit will be cleared. If not, the IFR will be transmitted after the EOD of the next received message.

If a transmitter underrun error occurs during transmission (caused by the programmer not writing another byte to the DLCBDR following the TDRE flag being set) the BDLC will automatically disable the transmitter after the byte currently in the shifter plus two extra 1-bits have been transmitted. The receiver will pick this up as a framing error and relay it in the State Vector Register as an invalid symbol error. The TMIFR0 bit will also be cleared.

If a loss of arbitration occurs when the BDLC is transmitting a multiple byte IFR without CRC, the BDLC will go to the loss of arbitration state, set the appropriate flag and cease transmission. The TMIFR0 bit will be cleared and no attempt will be made to retransmit the byte in the DLCBDR. If loss of arbitration occurs in the last bit of the IFR byte, two additional one bits (a passive long followed by an active short) **will** be sent out.

NOTE: *The extra logic 1s are an enhancement to the J1850 protocol which forces a byte boundary condition fault. This is helpful in preventing noise on the J1850 bus from corrupting a message.*

Byte Data Link

BDLC Data Register (DLCBDR)

This register is used to pass the data to be transmitted to the J1850 bus from the CPU to the BDLC. It is also used to pass data received from the J1850 bus to the CPU.

Address Offset: \$0003

	Bit 7	6	5	4	3	2	1	Bit 0
Read:	D7	D6	D5	D4	D3	D2	D1	D0
Write:								
Reset:	0	0	0	0	0	0	0	0

READ: any time

WRITE: any time

D7:D0 — Receive/Transmit Data (Bits 7 - 0)

Each data byte (after the first one) should be written only after a “Tx Data Register Empty” (TDRE) interrupt has occurred, or the DLCBSVR register has been polled indicating this condition.

Data read from this register will be the last data byte received from the J1850 bus. This received data should only be read after a “Rx Data Register Full” (RDRF) or “Received IFR byte” (RXIFR) interrupt has occurred or the DLCBSVR register has been polled indicating either of these two conditions.

The DLCBDR register is double buffered via a transmit shadow register and a receive shadow register. After the byte in the transmit shift register has been transmitted, the byte currently stored in the transmit shadow register is loaded into the transmit shift register. Once the transmit shift register has shifted the first bit out, the TDRE flag is set, and the shadow register is ready to accept the next byte of data.

The receive shadow register works similarly. Once a complete byte has been received, the receive shift register stores the newly received byte into the receive shadow register. The RDRF flag (or RXIFR flag if the received byte is part of an IFR) is set to indicate that a new byte of data has been received. The programmer has one BDLC byte reception time to read the shadow register and clear the RDRF or RXIFR flag before the shadow register is overwritten by the newly received byte.

If the user writes the first byte of a message to be transmitted to the DLCBDR and then determines that a different message should be transmitted, the user can write a new byte to the DLCBDR up until the transmission begins. This new byte will replace the original byte in the DLCBDR.

From the time a byte is written to the DLCBDR until it is transferred to the transmit shift register, the transmit shadow register is considered full and the byte pending transmission. If one of the IFR transmission control bits (TSIFR, TMIFR1, or TMIFR0 in DLCBCR2) is also set, the byte is pending transmission as an IFR. A byte pending transmission will be flushed from the transmit shadow register and the transmission canceled if one of the following occurs: a loss of arbitration or transmitter error on the byte currently being transmitted; a symbol error, framing error, bus fault, or BREAK symbol is received. If the byte pending transmission is an IFR byte, the reception of a message with a CRC error will also cause the byte in the transmit shadow register to be flushed.

To abort an in-progress transmission, the programmer should simply stop loading more data into the BDR. This will cause a transmitter underrun error and the BDLC will automatically disable the transmitter on the next non-byte boundary. This means that the earliest a transmission can be halted is after at least one byte (plus two extra 1-bits) has been transmitted. The receiver will pick this up as an error and relay it in the State Vector Register as an invalid symbol error.

Byte Data Link

BDLC Analog Round Trip Delay Register (DLCBARD)

This register is used to program the BDLC so that it compensates for the round trip delays of different external transceivers. Also the polarity of the receive pin (RxP) is set in this register.

Address Offset: \$0004

	Bit 7	6	5	4	3	2	1	Bit 0
Read:	0	RXPOL	0	0	BO3	BO2	BO1	BO0
Write:								
Reset:	0	1	0	0	0	1	1	1

= Unimplemented

READ: any time

WRITE: write once in normal and emulation modes.

Register functionality modified in special test mode.

Writes to unimplemented bits 7, 5, 4 are ignored.

RXPOL — Receive Pin Polarity (Bit 6)

The Receive pin Polarity bit is used to select the polarity of incoming signal on the receive pin. Some external analog transceiver inverts the receive signal from the J1850 bus before feeding back to the digital receive pin.

1 = Select normal/true polarity; true non-inverted signal from J1850 bus, i.e., the external transceiver does not invert the receive signal.

0 = Select inverted polarity, where external transceiver inverts the receive signal.

BO3-BO0 — BDLC Analog Roundtrip Delay Offset Field (Bits 3-0)

BO[3:0] adjust the transmitted symbol timings to account for the differing roundtrip delays found in different SAE J1850 analog transceivers. The allowable delay range is from 9 μ s to 24 μ s, with a nominal target of 16 μ s (reset value). Refer to [Table 117](#) for the BO[3:0] values corresponding to the expected transceiver delays and the resultant transmitter timing adjustment (in mux interface clock periods (t_{bdlc})). Refer to the analog transceiver device specification for

the expected roundtrip delay through both the transmitter and the receiver. The sum of these two delays makes up the total roundtrip delay value.

Table 117 BARD Values vs. Transceiver Delay and Transmitter Timing Adjustment

BARD Offset Bits (BO3,BO2,BO1,BO0)	Corresponding Expected Transceiver's delays (μ s)	Transmitter Symbol Timing Adjustment (t_{bdlc}) ¹
0000	9	9
0001	10	10
0010	11	11
0011	12	12
0100	13	13
0101	14	14
0110	15	15
0111	16	16
1000	17	17
1001	18	18
1010	19	19
1011	20	20
1100	21	21
1101	22	22
1110	23	23
1111	24	24
NOTE: 1. The transmitter symbol timing adjustment is the same for binary and integer bus frequencies.		

Byte Data Link

BDLC Rate Select Register (DLCBRSR) This register determines the divider prescaler value for the mux interface clock (f_{bdlc}).

Address Offset: \$0005

	Bit 7	6	5	4	3	2	1	Bit 0
Read:	0	0	R5	R4	R3	R2	R1	R0
Write:	Unimplemented							
Reset:	0	0	0	0	0	0	0	0

 = Unimplemented

READ: any time

WRITE: write once in normal and emulation modes.

Register functionality modified in special test mode.

Writes to unimplemented bits 7, 6 are ignored.

R5-R0 — Rate Select (Bits 5-0)

These bits determine the amount by which the frequency of the system clock signal is divided to generate the MUX Interface clock (f_{bdlc}) which defines the basic timing resolution of the MUX Interface. The value programmed into these bits is dependent on the chosen system clock frequency. See [Table 118](#) and [Table 119](#) for example rate selects for different bus frequencies. All divisor values from divide by 1 to divide by 64 are possible, but are not shown in the tables.

NOTE: *Although the maximum divider is 64, a divider which will generate a 1 MHz or 1.048576 MHz f_{bdlc} must be selected in order for J1850 communications to occur.*

NOTE: The BRSR is always loaded with “desired divisor” -1 and comes out of reset programmed for a divide by 1 clock rate (BRSR = \$00).

Table 118 BDLC Rate Selection for Binary Frequencies

IP bus clock frequency	R[5:0]	division	f_{bdlc}
$f_{CLOCK}=1.048576$ MHz	\$00	1	1.048576 MHz
$f_{CLOCK}=2.09715$ MHz	\$01	2	1.048576 MHz
$f_{CLOCK}=3.14573$ MHz	\$02	3	1.048576 MHz
$f_{CLOCK}=4.19430$ MHz	\$03	4	1.048576 MHz
$f_{CLOCK}=8.38861$ MHz	\$07	8	1.048576 MHz
$f_{CLOCK}=10.48576$ MHz	\$09	10	1.048576 MHz
$f_{CLOCK}=67.10886$ MHz	\$3F	64	1.048576 MHz

Table 119 BDLC Rate Selection for Integer Frequencies

IP bus clock frequency	R[5:0]	division	f_{bdlc}
$f_{CLOCK}=1.00000$ MHz	\$00	1	1.000000 MHz
$f_{CLOCK}=2.00000$ MHz	\$01	2	1.000000 MHz
$f_{CLOCK}=3.00000$ MHz	\$02	3	1.000000 MHz
$f_{CLOCK}=4.00000$ MHz	\$03	4	1.000000 MHz
$f_{CLOCK}=8.00000$ MHz	\$07	8	1.000000 MHz
$f_{CLOCK}=10.00000$ MHz	\$09	10	1.000000 MHz
$f_{CLOCK}=64.00000$ MHz	\$3F	64	1.000000 MHz

Byte Data Link

BDLC Control Register (DLCSCR)

The following register enables the BLDC_IP.

Address Offset: \$0006

	Bit 7	6	5	4	3	2	1	Bit 0
Read:	0	0	0	BDLCE	0	0	0	0
Write:								
Reset:	0	0	0	0	0	0	0	0

= Unimplemented

READ: any time

WRITE: any time

BDLCE — BDLC Enable (Bit 4)

This bit serves as a mux interface clock (f_{bdlc}) enable/disable for power savings.

- 1 = The mux interface clock (f_{bdlc}) and BDLC are enabled to allow J1850 communications to take place.
- 0 = The mux interface clock (f_{bdlc}) is disabled shutting down the BDLC for power saving. Bus clocks are still running allowing registers to be accessed.

BDLC Status Register (DLCBSTAT)

This register indicates the status of the BDLC.

Address Offset: \$0007

	Bit 7	6	5	4	3	2	1	Bit 0	
Read:	0	0	0	0	0	0	0	IDLE	
Write:	Unimplemented					Reserved		Unimplemented	
Reset:	0	0	0	0	0	0	0	0	

= Reserved or Unimplemented

READ: any time

WRITE: ignored in normal and emulation modes

Register functionality is modified in special test mode.

IDLE Idle (Bit 0)

This bit indicates when the BDLC is idle.

1 = BDLC has received IFS and no data is being transmitted or received.

0 = BDLC is either transmitting or receiving data.

NOTE: *BDLC is only idle after receiving IFS. The IDLE bit is 0 during reset since the BDLC needs to wait for an IFS before becoming idle. Noise on the bus will be filtered and the IDLE bit will remain unchanged.*

External Pin Descriptions

The BDLC module has a control bit, BDLCE, for two external pins, PM0 and PM1. The BDLCE bit enables and disables the BDLC and its J1850 functions. The transmit pin (Txp) function is multiplexed on the PM1 port and the receive pin (Rxp) function is multiplexed on the PM0 port. The BDLC pins are shared with the CAN0 pins. When the BDLC is enabled, the BDLC function takes control of these two shared pins.

NOTE: *If both BDLC and CAN0 are enabled, the CAN0 will take control of these two pins and no BDLC function will occur on these pins.*

Reset Initialization/Basic Operation

The reset state of each individual bit is listed within the Register Descriptions section [Register Descriptions](#) which details the registers and their bit-fields.

This section includes sample flows for initializing the BDLC and using it to transmit and receive messages.

Initialization Sequence

To initialize the BDLC, the user should first write the desired data to the configuration bits. The BDLC should then be taken out of digital and analog loopback mode and enabled. Exiting from loopback mode will

entail change of state indications in the DLCBSVR which must be dealt with. Once this is complete, CPU interrupts can be enabled (if desired), and then the BDLC module is capable of SAE J1850 serial network communication. For an illustration of the sequence necessary for initializing the BDLC, refer to [Figure 128](#).

Initializing the Configuration Bits

The first step necessary for initializing the BDLC following an MCU reset is to write the desired values to each of the BDLC control registers. This is best done by storing predetermined initialization values directly into these registers. The following description outlines a basic flow for initializing the BDLC. This basic flow does not detail more elaborate initialization routines, such as performing digital and analog loopback tests before enabling the BDLC for SAE J1850 communication. However, from the following descriptions and the BDLC specification, the user should be able to develop routines for performing various diagnostic procedures such as loopback tests.

Step 1 - Initialize DLCBARD

Begin initialization of the configuration bits by writing the desired analog transceiver configuration data into the DLCBARD register. Following this write to DLCBARD, all of these bits will become read only.

Step 2- Initialize DLCBRSR

The next step in BDLC initialization is to write the desired bus clock divisor minus one into the DLCBRSR register. The divisor should be chosen to generate a 1 MHz or 1.048576 MHz mux interface clock (f_{bdlc}). Following this write to DLCBRSR, all of these bits will become read only.

Step 3- Initialize DLCBCR2

The next step in BDLC initialization should be writing the configuration bits into the DLCBCR2 register. This initialization description assumes that the BDLC will be put into normal mode (not 4X mode), and that the BDLC should not yet exit either digital or analog loopback mode. Therefore, this step should write SMRST and DLOOP as logic ones, RX4XE as a logic zero, write NBFS to the desired level, and write TEOD, TSIFR, TMIFR1 and TMIFR0 as logic zeros. These last four bits **MUST** be written as logic zeros in order to prevent undesired operation of the BDLC.

*Step 4- Initialize
DLCBCR1*

The next step in BDLC initialization is to write the configuration bits in DLCBCR1. The CLKS bit should be written to its desired values at this time, following which it will become read-only. The IE bit should be written as a logic zero at this time so BDLC interrupts of the CPU will remain masked for the time being. The IMSG bit should be written as a logic one to prevent any receive events from setting the DLCBSVR until a valid SOF (or BREAK) symbol has been received by the BDLC.

**Exiting Loopback
Mode and
Enabling the BDLC**

Once the configuration bits have been written to the desired values, the BDLC should be taken out of loopback and connected to the SAE J1850 bus. This is done by clearing the DLOOP bit and then setting the BDLCE bit in the DLCSCR.

*Step 5- Perform
Loopback Tests
(optional)*

Once the BDLC is configured for desired operation, the user may wish to perform digital and/or analog loopback tests to determine the integrity of the link to the SAE J1850 network. This would involve leaving the DLOOP bit (DLCBCR2) set, setting the BDLCE bit, performing the desired loopback tests and finally exiting digital loopback mode by clearing DLOOP in the DLCBCR2.

*Step 6- Exit
Loopback Mode
and enable the
BDLC*

If loopback mode tests are not to be performed the BDLC can be removed from digital loopback mode by clearing the DLOOP bit. The BDLC can then be enabled by setting the BDLCE bit in the DLCSCR.

Once DLOOP is cleared and BDLCE is set, the BDLC is ready for SAE J1850 communication. However, to ensure that the BDLC does not attempt to receive a message already in progress or to transmit a message while another device is transmitting, the BDLC must first observe an EOF symbol on the bus before the receiver will be activated. To activate the transmitter, the BDLC will need to observe an Inter-Frame Separator symbol.

**Enabling BDLC
Interrupts**

The final step in readying the BDLC for proper communication is to clear any pending interrupt sources and then, if desired, enable BDLC interrupts of the CPU.

Byte Data Link

*Step 7- Clear
Pending BDLC
Interrupts*

In order to ensure that the BDLC does not immediately generate a CPU interrupt when interrupts are enabled, the user should read the DLCBSVR to determine if any BDLC interrupt sources are pending before setting the IE bit in the BCR1. If the BSVR reads as a%00000000, no interrupts are pending and the user is free to enable BDLC interrupts, if desired.

If the DLCBSVR indicates that an interrupt is pending, the user should perform whatever actions are necessary to clear the interrupt source before enabling the interrupts. Whether any interrupts are pending will depend primarily upon how much time passes between the exit from loopback modes and enabling the BDLC and the enabling of interrupts. It is a good practice to always clear any source of interrupts before enabling interrupts on any MCU subsystem.

If any interrupts are pending ($\text{DLCBSVR} \neq \%00000000$), then each interrupt source should be dealt with accordingly. Once all of the interrupt sources have been dealt with, the DLCBSVR should read%00000000, and the user is then free to enable BDLC interrupts.

*Step 8- Enable
BDLC Interrupts*

The last step in initializing the BDLC module is to enable interrupts to the CPU, if so desired. This is done by simply setting the IE bit in the DLCBCR1. Following this, the BDLC module is ready for operating in interrupt mode. If the user chooses not to enable interrupts, the DLCBSVR must be polled periodically to ensure that state changes in the BDLC are detected and dealt with appropriately.

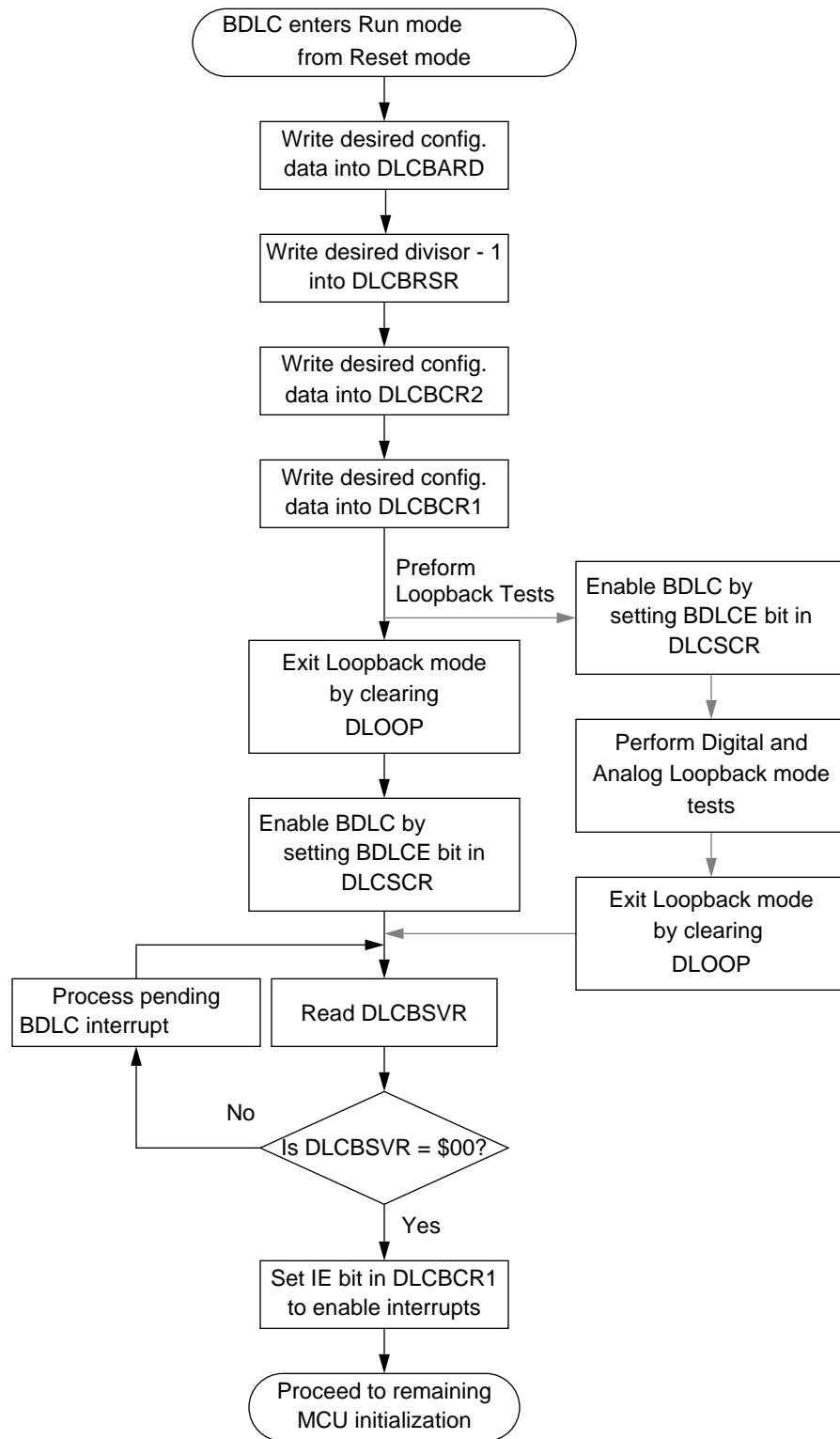

Figure 128 Basic BDLC Initialization Flowchart

Transmitting A Message

The design of the BDLC module enables the user to easily handle message reception and message transmission separately. This can greatly simplify the communication software, as all received messages can be handled virtually the same, regardless of their origin.

This chapter will therefore describe only the steps necessary for transmitting a message, and will not address the resulting reception of that message by the BDLC. Message reception is described in [Receiving A Message](#). Later sections will deal with transmitting and receiving In-Frame Responses on the SAE J1850 bus.

BDLC Transmission Control Bits

There is only one BDLC control bit which is used when transmitting a message onto the SAE J1850 bus. This bit, the Transmit End of Data (TEOD) bit, is set by the user to indicate to the BDLC that the last byte of that part of the message frame has been loaded into the DLCBDR. The TEOD bit, located in DLCBCR2, is also used when transmitting an In-Frame Response (IFR), but that usage is described in [Transmitting An In-Frame Response \(IFR\)](#). Setting the TEOD bit indicates to the BDLC that the last byte written to the BDLC Data Register is the final byte to be transmitted, and that following this byte a CRC byte and EOD symbol should be transmitted automatically. Setting the TEOD bit will also inhibit any further TDRE interrupts until TEOD is cleared. The TEOD bit will be cleared on the rising edge of the first bit of the transmitted CRC byte, or if an error or loss of arbitration is detected on the bus.

BDLC Data Register

The BDLC Data Register is a double-buffered register which is used for handling the transmitted and received message bytes. Bytes to be transmitted onto the SAE J1850 bus are written to the DLCBDR, and bytes received from the bus by the BDLC are read from the DLCBDR. Since this register is double buffered, bytes written into it cannot be read by the CPU. If this is attempted, the byte which is read will be the last byte placed in the DLCBDR by the BDLC, not the last byte written to the

DLCBDR by the CPU. For an illustration of the DLCBDR, refer to [BDLC Data Register \(DLCBDR\)](#).

Transmitting a Message with the BDLC

To transmit a message using the BDLC, the user just writes the first byte of the message to be transmitted into the DLCBDR, initiating the transmission process. When the TDRE status appears in the DLCBSVR, the user writes the next byte into the DLCBDR. Once all of the bytes have been loaded into the DLCBDR, the user sets the TEOD bit, and the BDLC completes the message transmission. What follows is an overview of the basic steps required to transmit a message onto an SAE J1850 network using the BDLC. For an illustration of this sequence, refer to [Basic BDLC Transmit Flowchart](#).

NOTE: *Due to the byte-level architecture of the BDLC module, the 12-byte limit on message length as defined in SAE J1850 must be enforced by the user's software. The number of bytes in a message (transmitted or received) has no meaning to the BDLC.*

Step 1: Write the First Byte into the DLCBDR

To initiate a message transmission, the CPU simply loads the first byte of the message to be transmitted into the DLCBDR. The BDLC will then perform the necessary bus acquisition duties to determine when the message transmission can begin.

Once the BDLC determines that the SAE J1850 bus is free, a Start of Frame (SOF) symbol will be transmitted, followed by the byte written to the DLCBDR. Once the BDLC readies this byte for transmission, the DLCBSVR will reflect that the next byte can be written to the DLCBDR (TDRE interrupt).

NOTE: *If the user writes the first byte of a message to be transmitted to the DLCBDR and then determines that a different message should be transmitted, the user can write a new byte to the DLCBDR up until the transmission begins. This new byte will replace the original byte in the DLCBDR.*

Byte Data Link

Step 2: When TDRE is Indicated, Write the Next Byte into the DLCBDR

When a TDRE state is reflected in the BSVR, the CPU writes the next byte to be transmitted into the BDR. This step is repeated until the last byte to be transmitted is written to the DLCBDR.

NOTE: *Due to the design and operation of the BDLC, when transmitting a message the user may write two, or possibly even three of the bytes to be transmitted into the DLCBDR before the first RDRF interrupt occurs. For this reason, the user should never use receive interrupts to control the sequencing of bytes to be transmitted.*

Step 3: Write the Last Byte to the DLCBDR and Set TEOD

Once the user has written the last byte to be transmitted into the DLCBDR, the user then sets the TEOD bit in DLCBCR2. When the TEOD bit is set, once the byte written to the DLCBDR is transmitted onto the bus, the BDLC will begin transmitting the 8-bit CRC byte, as specified in SAE J1850. Following the CRC byte, the BDLC will transmit an EOD symbol onto the SAE J1850 bus, indicating that this part of the message has been completed. If no IFR bytes are transmitted following the EOD, an EOF will be recognized and the message will be complete.

Setting the TEOD bit is the last step the CPU needs to take to complete the message transmission, and no further transmission-related interrupts will occur. Once the message has been completely received by the BDLC, an EOF interrupt will be generated. However, this is technically a receive function which can be handled by the message reception routine.

NOTE: *While the TEOD bit is typically set immediately following the write of the last byte to the BDR, it is also acceptable to wait until a TDRE interrupt is generated before setting the TEOD bit. While the example flowchart in [Figure 129](#) shows the TEOD bit being set after the write to the BDR, either method is correct. If a TDRE interrupt is pending, it will be cleared when the TEOD bit is set.*

Transmitting Exceptions

While this is the basic transmit flow, at times the message transmit process will be interrupted. This can be due to a loss of arbitration to a higher priority message or due to an error being detected on the

network. For the transmit routine, either of these events can be dealt with in a similar manner.

Loss of Arbitration

If a loss of arbitration (LOA) occurs while the BDLC is transmitting onto the SAE J1850 bus, the BDLC will immediately stop transmitting, and a LOA status will be reflected in the DLCBSVR. If the loss of arbitration has occurred on a byte boundary, an RDRF interrupt may also be pending once the LOA interrupt is cleared.

When a loss of arbitration occurs, the J1850 message handling software should immediately switch into the receive mode. If the TEOD bit was set, it will be cleared automatically. **If another attempt is to be made to transmit the same message, the user must start the transmit sequence over from the beginning of the message.**

Error Detection

Similar to a loss of arbitration, if any error (except a CRC error) is detected on the SAE J1850 bus during a transmission, the BDLC will stop transmitting immediately. The byte which was being transmitted will be discarded, and the “Symbol Invalid or Out of Range” status will be reflected in the DLCBSVR. As with the loss of arbitration, if the TEOD bit was set, it will be cleared automatically, and any attempt to transmit the same message will have to start from the beginning.

If a CRC error occurs following a transmission, this will also be reflected in the DLCBSVR. However, since the CRC error is really a receive error based on the received CRC byte, at this point all bytes of the message will have been transmitted. It is therefore up to the user’s software to determine if another attempt should be made to transmit the message in which the error occurred.

Transmitter Underrun

A transmitter underrun can occur when a TDRE interrupt is not serviced in a timely fashion. If the last byte loaded into the DLCBDR is completely transmitted onto the network before the next byte is loaded into the BDR, a transmitter underrun will occur. If this does happen, the BDLC will transmit two additional logic ones to ensure that the partial message which was transmitted onto the bus does not end on a byte boundary. This will be followed by an EOD and EOF symbol. The only indication to the CPU that an underrun occurred is the Symbol Invalid or Out of Range

error which will be indicated in the DLCBSVR. As with the other errors, it is up to the user's software to determine if another transmission attempt should be made.

*In-Frame
Response to a
Transmitted
Message*

If an In-Frame Response (IFR) is received following the transmission of a message, the status indicating that an IFR byte has been received will be indicated in the DLCBSVR before an EOF is indicated. Refer to [Receiving An In-Frame Response \(IFR\)](#) for a description of how to handle the reception of IFR bytes.

**Aborting a
Transmission**

The BDLC module does not have a mechanism designed specifically for aborting a transmission. Since the module transmits each message on a byte-by-byte basis, there is little need to implement an abort mechanism. If the user has loaded a byte into the DLCBDR to initiate a message transmission and decides to send a different message, the byte in the DLCBDR can be replaced, right up to the point that the message transmission begins.

If the user has loaded a byte into the DLCBDR and then decides not to send any message at all, the user can let the byte transmit, and when the TDRE interrupt occurs let the transmitter underrun. This will cause two extra logic ones followed by an EOF to be transmitted. While this method may require a small amount of bus bandwidth, the need to do this should be very rare. Replacing the byte originally written to the BDR with \$FF will also increase the probability of the transmitter losing arbitration if another node begins transmitting at the same time, also reducing the bus bandwidth needed.

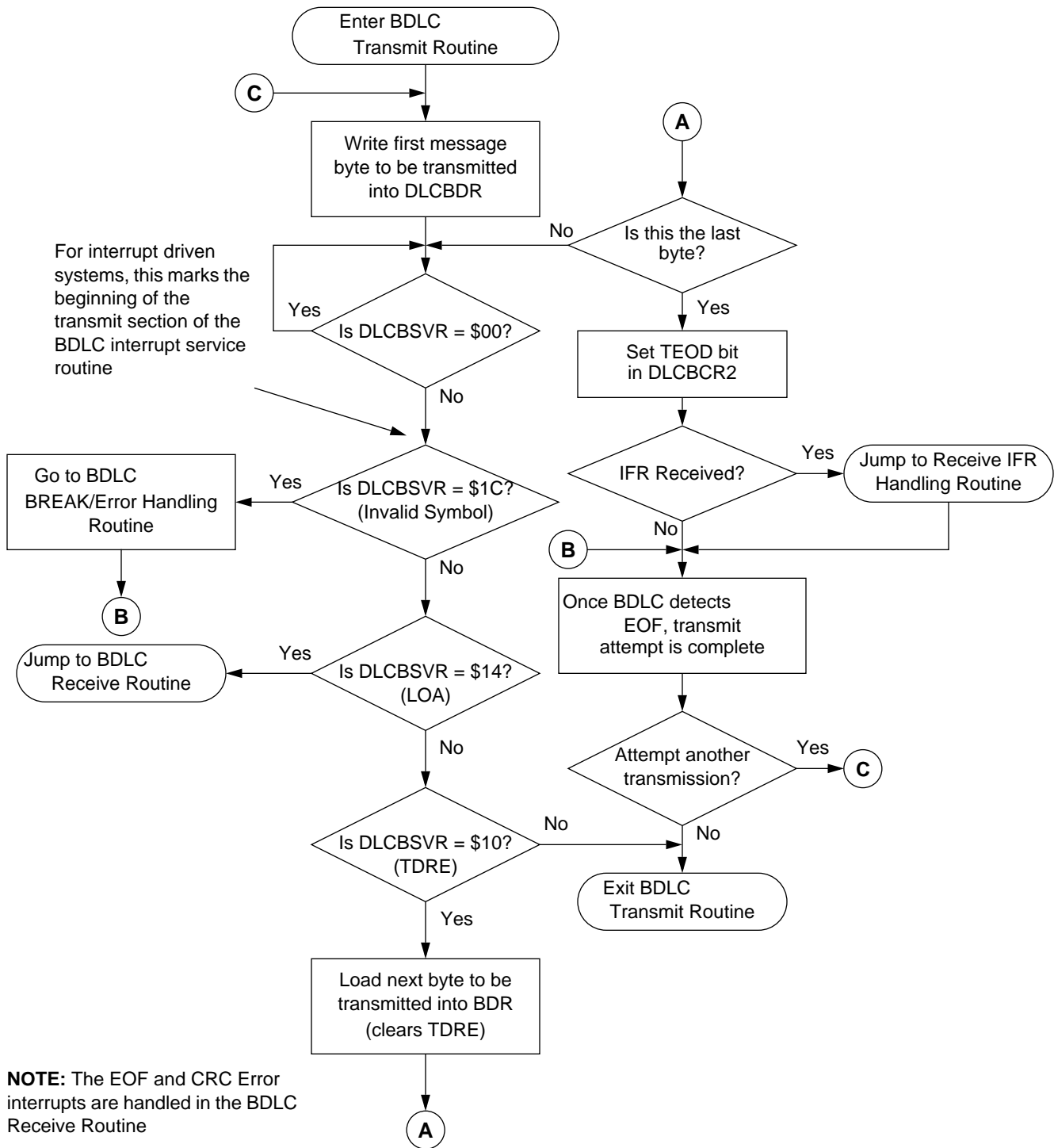

Figure 129 Basic BDLC Transmit Flowchart

Receiving A Message

The design of the BDLC makes it especially easy to use for receiving messages off of the SAE J1850 bus. When the first byte of a message comes in, the DLCBSVR will indicate to the CPU that a byte has been received. As each successive byte is received, that will in turn be reflected in the DLCBSVR. When the message is complete and the EOF has been detected on the bus, the DLCBSVR will reflect this, indicating that the message is complete.

The basic steps required for receiving a message from the SAE J1850 bus are outlined below. For more information on receiving IFR bytes, refer to [Receiving An In-Frame Response \(IFR\)](#).

BDLC Reception Control Bits

The only control bit which is used for message reception, the IMMSG bit, is actually used to prevent message reception. As described in [IMMSG — Ignore Message \(Bit 7\)](#), when the IMMSG bit is set BDLC interrupts of the CPU are inhibited until the next SOF symbol is received. This allows the BDLC to ignore the remainder of a message once the CPU has determined that it is of no interest. This helps reduce the amount of CPU overhead used to service messages received from the SAE J1850 network, since otherwise the BDLC would require attention from the CPU for each byte broadcast on the network. The IMMSG bit is cleared when the BDLC receives an SOF symbol, or it can also be cleared by the CPU.

NOTE: *While the IMMSG bit can be used to prevent the CPU from having to service the BDLC for every byte transmitted on the SAE J1850 bus, **the IMMSG bit should never be used to ignore the BDLC's own transmission.** Because setting the IMMSG bit prevents all DLCBSVR bits from being updated until an SOF is received, the user would not receive any further transmit-related interrupts until another SOF was received, making it very difficult for the CPU to complete the transmission correctly.*

Receiving a Message with the BDLC

Receiving a message using the BDLC is extremely straight-forward. As each byte of a message is received and placed into the DLCBDR, the BDLC will indicate this to the CPU with an Rx Data Register Full (RDRF) status in the DLCBSVR. When an EOF symbol is received, indicating to the CPU that the message is complete, this too will be reflected in the DLCBSVR.

Outlined below are the basic steps to be followed for receiving a message from the SAE J1850 bus with the BDLC. For an illustration of this sequence, refer to [Basic BDLC Receive Flowchart](#).

Step 1: When RDRF Interrupt Occurs, Retrieve Data Byte

When the first byte of a message following a valid SOF symbol is received that byte is placed in the DLCBDR, and an RDRF state is reflected in the DLCBSVR. No indication of the SOF reception is made, since the end of the previous message is marked by an EOF indication. The first RDRF state following this EOF indication should allow the user to determine when a new message begins.

The RDRF interrupt is cleared when the received byte is read from the DLCBDR. Once this is done, no further CPU intervention is necessary until the next byte is received, and this step is repeated.

All bytes of the message, including the CRC byte, will be placed into the DLCBDR as they are received for the CPU to retrieve.

Step 2: When an EOF is Received, the Message is Complete

Once all bytes (including the CRC byte) have been received from the bus, the bus will be idle for a time period equal to an EOD symbol. Once the EOD symbol is received, the BDLC will verify that the CRC byte is correct. If the CRC byte is not correct, this will be reflected in the DLCBSVR.

If no In-Frame Response bytes are transmitted following the EOD symbol, the EOD will transition into an EOF symbol. When the EOF is received it will be reflected in the DLCBSVR, indicating to the user that the message is complete. If IFR bytes do follow the first EOD symbol, once they are complete another EOD will be transmitted, followed by an EOF.

Once the EOF state is reflected in the DLCBSVR, this indicates to the user that the message is complete, and that when another byte is received it is the first byte of a new message.

Filtering Received Messages

No message filtering hardware is included on the BDLC, so all message filtering functions must be performed in software. Because the BDLC handles each message on a byte-by-byte basis, message filtering can be done as each byte is received, rather than after the entire message is complete. This enables the CPU to decide while a message is still in progress whether or not that message is of any interest.

At any point during a message, if the CPU determines that the message is of no interest the IMSG bit can be set. Setting the IMSG bit commands the BDLC not to update the DLCBSVR until the next valid SOF is received. This prevents the CPU from having to service the BDLC for each byte of every message sent over the network.

Receiving Exceptions

As with a message transmission, this basic message reception flow can be interrupted if errors are detected by the BDLC. This can occur if an incorrect CRC is detected or if an invalid or out of range symbol appears on the SAE J1850 bus. A problem can also arise if the CPU fails to service the DLCBDR in a timely manner during a message reception.

Receiver Overrun

Once a message byte has been received, the CPU must service the DLCBDR before the next byte is received, or the first byte will be lost. If the DLCBDR is not serviced quickly enough, the next byte received will be written over the previous byte in the DLCBDR. No receiver overrun indication is made to the CPU. If the CPU fails to service the BDLC during the reception of an entire message, the byte remaining in the DLCBDR will be last byte received (usually a CRC byte).

Once a receiver overrun occurs, there is no way for the CPU to recover the lost byte(s), so the entire message should be discarded. To prevent receiver overrun, the user should ensure that a BDLC RDRF interrupt will be serviced before the next byte can be received. When polling the DLCBSVR, the user should select a polling interval which will provide timely monitoring of the BDLC.

CRC Error

If a CRC error is detected during a message reception, this will be reflected in the BSVR once an EOD time is recognized by the BDLC. Since all bytes of the message will have been received when this error is detected, it is up to the user to ensure that all the received message bytes are discarded.

Invalid or Out of Range Symbol

If an invalid or out of range symbol, a framing error or a BREAK symbol is detected on the SAE J1850 bus during the reception of a message, the BDLC will immediately stop receiving the message and discard any partially received byte. The “Symbol Invalid or Out of Range” status will immediately be reflected in the DLCBSVR. Following this the BDLC will wait until the bus has been idle for a time period equal to an EOF symbol before receiving another message. As with the CRC error, the user should discard any partially received message if this occurs.

In-Frame Response to a Received Message

As mentioned above, if one or more IFR bytes are received following the reception of a message, the status indicating the reception of the IFR byte(s) will be indicated in the DLCBSVR before the EOF is indicated. Refer to [Receiving An In-Frame Response \(IFR\)](#) for a description of how to deal with the reception of IFR bytes.

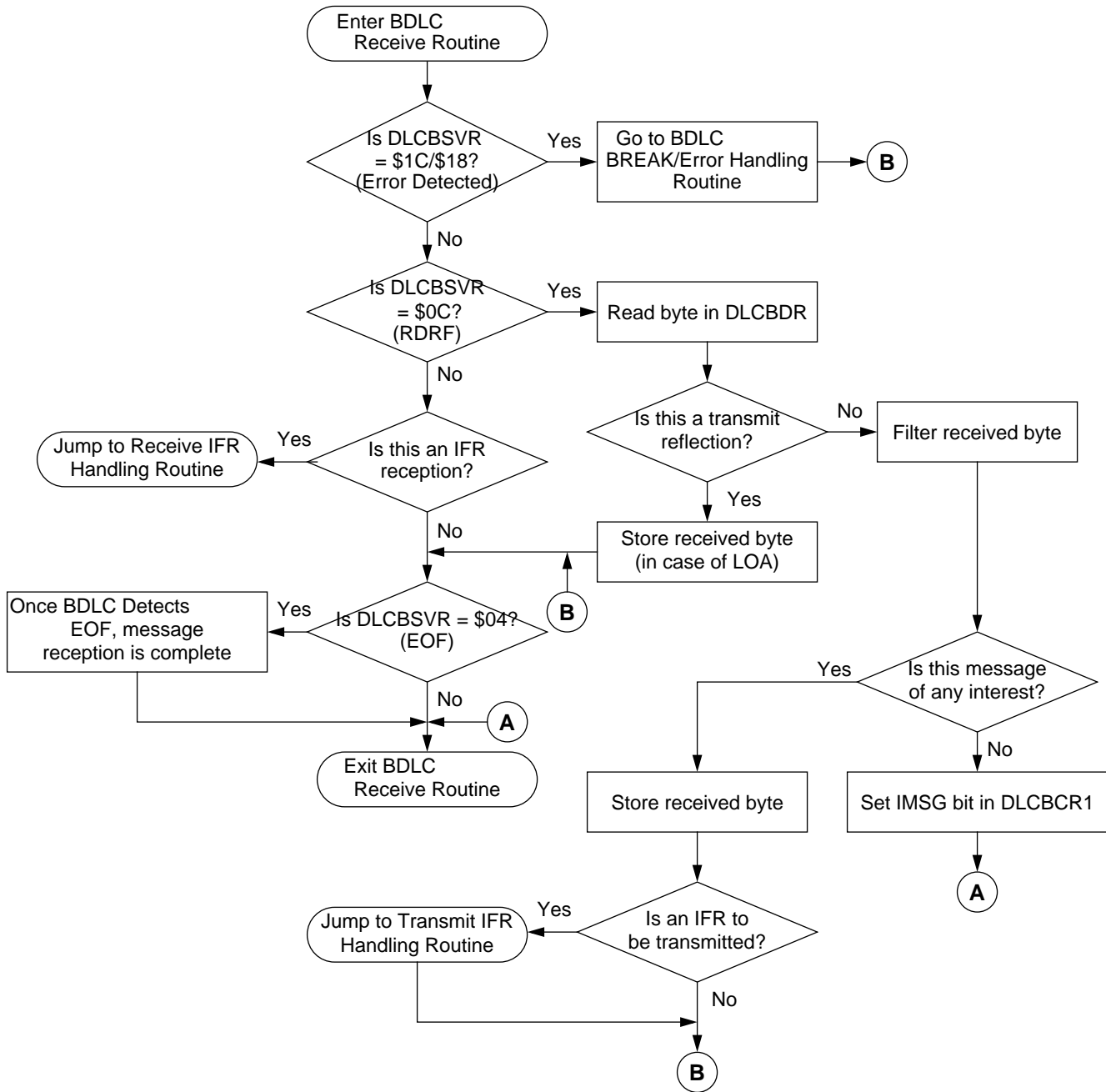

Figure 130 Basic BDLC Receive Flowchart

Transmitting An In-Frame Response (IFR)

The BDLC can be used to transmit all four types of In-Frame Response (IFR) which are defined in SAE J1850. A very brief definition of each IFR type is given below. For a more detailed description of each, refer the SAE J1850 document.

The explanation regarding IFR support by the BDLC which assumes the user is familiar with the use of IFRs as defined in SAE J1850, and understands the message header bit encoding and normalization bit formats which are used with the different types of IFRs. For more information on this, refer to the SAE J1850 document.

IFR Types Supported by the BDLC

SAE J1850 defines four distinct types of IFR. The first (and most basic) IFR is Type 0, or no IFR. IFR types 1, 2 & 3 are each made up of one or more bytes and, depending upon the type used, may be followed by a CRC byte. The BDLC is designed to allow the user to transmit and receive all types of SAE J1850 IFRs, but only the network framing/error checking/bus acquisition duties are performed by the BDLC. The user is responsible for determining the type of IFR to be transmitted, the number of retries to be made (if allowed), and the allowable number of bytes to be transmitted.

IFR Type 0: No Response

The most basic type of IFR is no IFR. The Type 0 IFR, as defined in SAE J1850, is no response. The EOD and EOF symbols follow directly after the CRC byte at the end of the message frame being transmitted. This type of IFR is, of course, inherently supported by the BDLC with no additional user intervention required.

IFR Type 1: Single Byte from a Single Responder

SAE J1850 defines the Type 1 IFR as a single byte from a single receiver. This type of IFR is used to acknowledge to the transmitter that the message frame was transmitted successfully on the network, and that at least one receiver received it correctly. A Type 1 IFR generally consists of the physical node ID of the receiver responding to the message, with no CRC byte appended. This type of response is used for Broadcast-type messages, where there may be several intended

receivers for a message but the transmitter only wants to know that at least one node received it. In this case, all receivers will begin transmitting their node ID following the EOD. Since all nodes on an SAE J1850 network have a unique node ID, if multiple nodes begin transmitting their node ID simultaneously, arbitration takes place. The node with the highest priority (lowest value) ID wins this arbitration process, and that node's ID makes up the IFR. No retries are attempted by the nodes which lose arbitration during a Type 1 IFR transmission.

A Type 1 IFR can also be used as a response to a physically addressed message, where the only intended receiver is the one which responds. In this case, no arbitration would take place during the IFR transmission, but the resulting IFR would still consist of a single byte.

*IFR Type 2: Single
Byte from Multiple
Responders*

The Type 2 IFR, as defined in SAE J1850, is a series of single bytes, each transmitted by a different responder. This IFR type not only acknowledges to the transmitter that the message was transmitted successfully, but also reveals which receivers actually received the message. As with the Type 1 IFR, no CRC byte is appended to the end of a Type 2 IFR.

This IFR type is typically used with Function-type messages, where the original transmitter may need to know which nodes actually received the message. The basic difference between this type of IFR and the Type 1 IFR is that the nodes which lose arbitration while attempting to transmit their node ID during a Type 2 IFR wait until the byte which wins arbitration is transmitted and then again attempt to transmit their node ID onto the bus. The result is a series of node IDs, one from each receiver of the original message.

*IFR Type 3: Multiple
Bytes from a Single
Responder*

The last type of IFR defined by SAE J1850 is the Type 3 IFR. This IFR type consists of one or more bytes from a single responder. This type of IFR is used to return data to the original transmitter within the original message frame. This type of IFR may or may not have a CRC byte appended to it.

The Type 3 IFR is typically used with Function Read-type or Function Query-type messages, where the original transmitter is requesting data from the intended receiver. The node requesting the data transmits the

initial portion of the message, and the intended receiver responds by transmitting the desired data in an IFR. In most cases, the original message requiring a Type 3 IFR is addressed to one particular node, so no arbitration should take place during the IFR portion of the message.

BDLC IFR Transmit Control Bits

The BDLC has three bits which are used to control the transmission of an In-Frame Response. These bits, all located in DLCBCR2, are TSIFR, TMIFR1 and TMIFR0. Each is used in conjunction with the TEOB bit to transmit one of three IFR types defined in SAE J1850. What follows is a brief description of each bit.

Because each of the bits used for transmitting an IFR with the BDLC is used to transmit a particular type of IFR, only one bit should be set by the CPU at a time. However, should more than one of these bits get set at one time, a priority encoding scheme is used to determine which type of IFR is sent. This scheme prevents unpredictable operation caused by conflicting signals to the BDLC. [Table 120](#) illustrates which IFR bit will actually be acted upon by the BDLC should multiple IFR bits get set at the same time.

NOTE: *As with transmitted messages, IFRs transmitted by the BDLC will also be received by the BDLC. For a description of how IFR bytes received by the BDLC should be handled, refer to [Receiving An In-Frame Response \(IFR\)](#).*

Table 120 IFR Control Bit Priority Encoding

Read/Write			Actual		
TSIFR	TMIFR1	TMIFR0	TSIFR	TMIFR1	TMIFR0
0	0	0	0	0	0
1	X	X	1	0	0
0	1	X	0	1	0
0	0	1	0	0	1

Byte Data Link

**Transmit Single
Byte IFR**

The Transmit Single Byte IFR (TSIFR) bit in DLCBCR2 is used to transmit Type 1 and Type 2 IFRs onto the SAE J1850 bus. If this bit is set after a byte is loaded into the BDR, the BDLC will attempt to send that byte, preceded by the appropriate Normalization Bit, as a single byte IFR without a CRC. If arbitration is lost, the BDLC will automatically attempt to transmit the byte again (without a Normalization Bit) as soon as the byte winning arbitration completes transmission. Attempts to transmit the byte will continue until either the byte is successfully transmitted, the TEOD bit is set by the user or an error is detected on the bus.

The user must set the TSIFR bit before the EOD following the main part of the message frame is received, or no IFR transmit attempts will be made for the current message. If another node does transmit an IFR to this message or a reception error occurs, the TSIFR bit will be cleared. If not, the IFR will be transmitted after the EOD of the next received message.

The TSIFR bit will be automatically cleared once the EOD following one or more IFR bytes has been received or an error is detected on the bus.

**Transmit Multi-Byte
IFR 1**

The Transmit Multi-Byte IFR 1 (TMIFR1) bit is used to transmit an SAE J1850 Type 3 IFR with a CRC byte appended. If this bit is set after the user has loaded the first byte of a multi-byte IFR into the DLCBDR, the BDLC will begin transmitting that byte, preceded by the appropriate Normalization Bit, onto the SAE J1850 bus. Once this happens a TDRE interrupt will occur, indicating to the user that the next IFR byte should be loaded into the DLCBDR. When the last byte to be transmitted is written to the DLCBDR, the user sets the TEOD bit. This will cause a CRC byte and an EOD symbol to be transmitted following the last IFR byte.

As with the TSIFR bit, the TMIFR1 bit must be set before the EOD symbol is received, or it will remain cleared and no IFR transmit attempt will be made. The TMIFR1 bit will be cleared once the CRC byte and EOD are transmitted, if an error is detected on the bus, if a loss of arbitration occurs during the IFR transmission or if a transmitter underrun occurs when the user fails to service the TDRE interrupt in a

timely manner. If a loss of arbitration occurs while the Type 3 IFR is being transmitted, transmission will halt immediately and the loss of arbitration will be indicated in the DLCBSVR.

Transmit Multi-Byte IFR 0

The Transmit Multi-Byte IFR 0 (TMIFR0) bit is used to transmit an SAE J1850 Type 3 IFR without a CRC byte appended. If this bit is set after the user has loaded the first byte of a multi-byte IFR into the DLCBDR, the BDLC will begin transmitting that byte, preceded by the appropriate Normalization Bit, onto the SAE J1850 bus. Once this happens a TDRE interrupt will occur, indicating to the user that the next IFR byte should be loaded into the DLCBDR. When the last byte to be transmitted is written to the DLCBDR, the user sets the TEOD bit. This will cause an EOD symbol to be transmitted following the last IFR byte.

As with the TSIFR and TMIFR1 bits, the TMIFR0 bit must be set before the EOD symbol is received, or it will remain cleared and no IFR transmit attempt will be made. The TMIFR0 bit will be cleared once the CRC byte and EOD are transmitted, if an error is detected on the bus, if a loss of arbitration occurs during the IFR transmission or if a transmitter underrun occurs when the user fails to service the TDRE interrupt in a timely manner. If a loss of arbitration occurs while the Type 3 IFR is being transmitted, transmission will halt immediately and the loss of arbitration will be indicated in the DLCBSVR.

NOTE: *The TMIFR0 bit should not be used to transmit a Type 1 IFR. If a loss of arbitration occurs on the last bit of a byte being transmitted using the TMIFR0 bit, two extra logic ones will be transmitted to ensure that the IFR will not end on a byte boundary. This can cause an error in a Type 1 IFR.*

Transmitting An IFR with the BDLC

While the design of the BDLC makes the transmission of each type of IFR similar, the steps necessary for sending each will be discussed. Again, a discussion of the bytes making up any particular IFR is not within the scope of this document. For a more detailed description of the use of IFRs on an SAE J1850 network, refer to the SAE J1850 document.

Byte Data Link

Transmitting a Type 1 IFR

To transmit a Type 1 IFR, the user loads the byte to be transmitted into the DLCBDR and sets both the TSIFR bit and the TEOD bit. This will direct the BDLC to attempt transmitting the byte written to the DLCBDR one time, preceded by the appropriate Normalization Bit. If the transmission is not successful, the byte will be discarded and no further transmission attempts will be made. For an illustration of the steps described below, refer to [Transmitting A Type 1 IFR](#).

Step 1: Load the IFR Byte into the BDR

The user begins initiation of a Type 1 IFR by loading the desired IFR byte into the DLCBDR. If a byte has already been written into the DLCBDR for transmission as a new message, the user can simply write the IFR byte to the DLCBDR, replacing the previously written byte. This must be done before the first EOD symbol is received.

Step 2: Set the TSIFR and TEOD Bits

The final step in transmitting a Type 1 IFR with the BDLC is to set the TSIFR and TEOD bits in DLCBCR2. Setting both bits will direct the BDLC to make one attempt at transmitting the byte in the DLCBDR as an IFR. If the byte is transmitted successfully, or if an error or loss of arbitration occurs, TEOD and TSIFR will be cleared and no further transmit attempts will be made.

Transmitting a Type 2 IFR

To transmit a Type 2 IFR, the user loads the byte to be transmitted into the DLCBDR and sets the TSIFR bit. Once this is done, the BDLC will attempt to transmit the byte in the DLCBDR as a single byte IFR, preceded by the appropriate Normalization Bit. If the first BDLC loses arbitration on the first attempt, it will make repeated attempts to transmit this byte until it is successful, an error occurs or the user sets the TEOD bit.

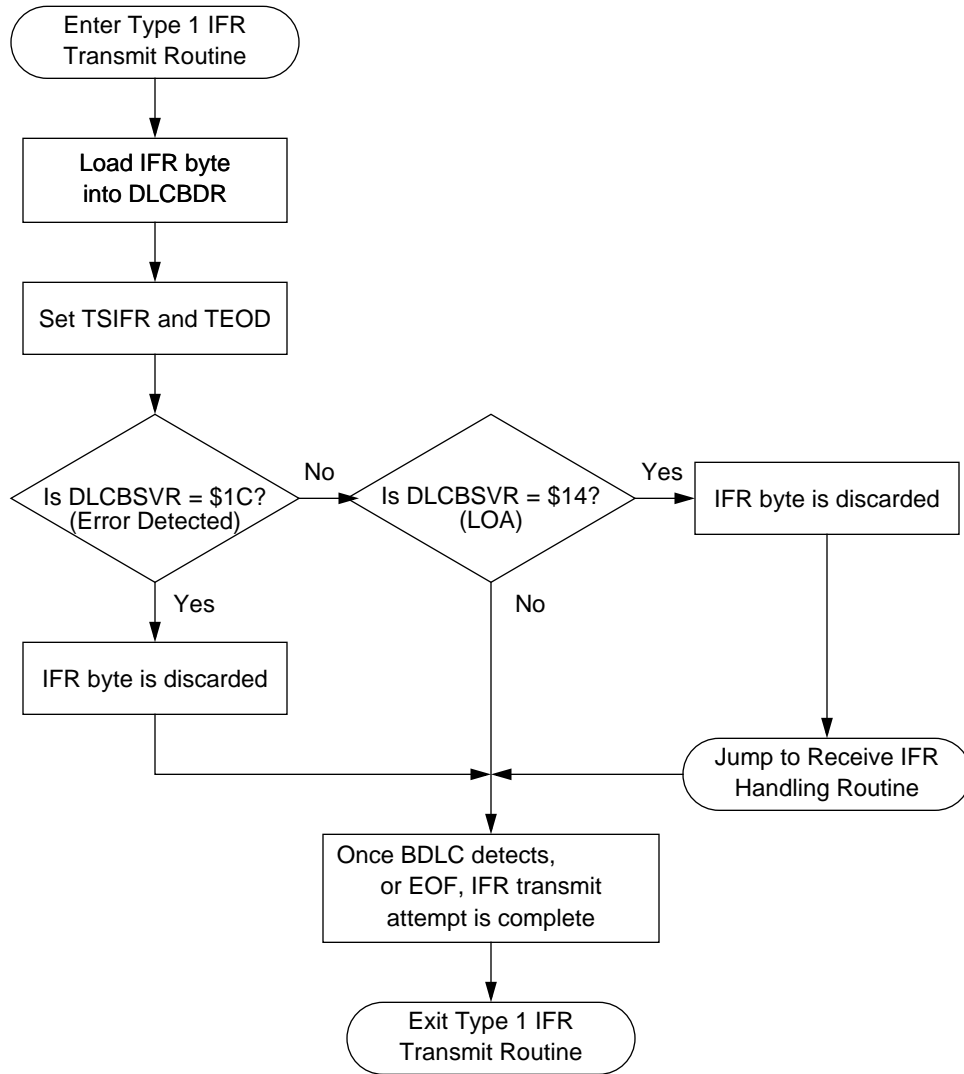

Figure 131 Transmitting A Type 1 IFR

Step 1: Load the IFR Byte into the BDR

As with the Type 1 IFR, the user begins initiation of a Type 2 IFR by loading the desired IFR byte into the DLCBDR. If a byte has already been written into the DLCBDR for transmission as a new message, the user can simply write the IFR byte to the DLCBDR, replacing the previously written byte. This must be done before the first EOD symbol is received.

Byte Data Link

Step 2: Set the TSIFR Bit

The second step necessary for transmitting a Type 2 IFR is to set the TSIFR bit in DLCBCR2. Setting this bit will direct the BDLC to attempt to transmit the byte in the DLCBDR as an IFR until it is successful. If the byte is transmitted successfully, or if an error or loss of arbitration occurs, TSIFR will be cleared and no further transmit attempts will be made.

Step 3: If Necessary, Set the TEOD Bit

The third step in transmitting a Type 2 IFR is only necessary if the user wishes to halt the transmission attempts. This may be necessary if the BDLC's attempt to transmit the byte loaded into the DLCBDR continually loses arbitration, and the overall message length approaches the 12-byte limit as defined in SAE J1850.

If it becomes necessary to halt the IFR transmission attempts, the user simply sets the TEOD bit in BCR2. If the BDLC is between transmission attempts, it will make one more attempt to transmit the IFR byte. If it is transmitting the byte when TEOD is set, the BDLC will continue the transmission until it is successful or it loses arbitration to another transmitter. At this point it will then discard the byte and make no more transmit attempts.

NOTE: *When transmitting a Type 2 IFR, the user should monitor the number of IFR bytes received to ensure that the overall message length does not exceed the 12-byte limit for the length of SAE J1850 messages. The user should set the TEOD bit when the 11th byte is received, which will prevent the 12-byte limit from being exceeded.*

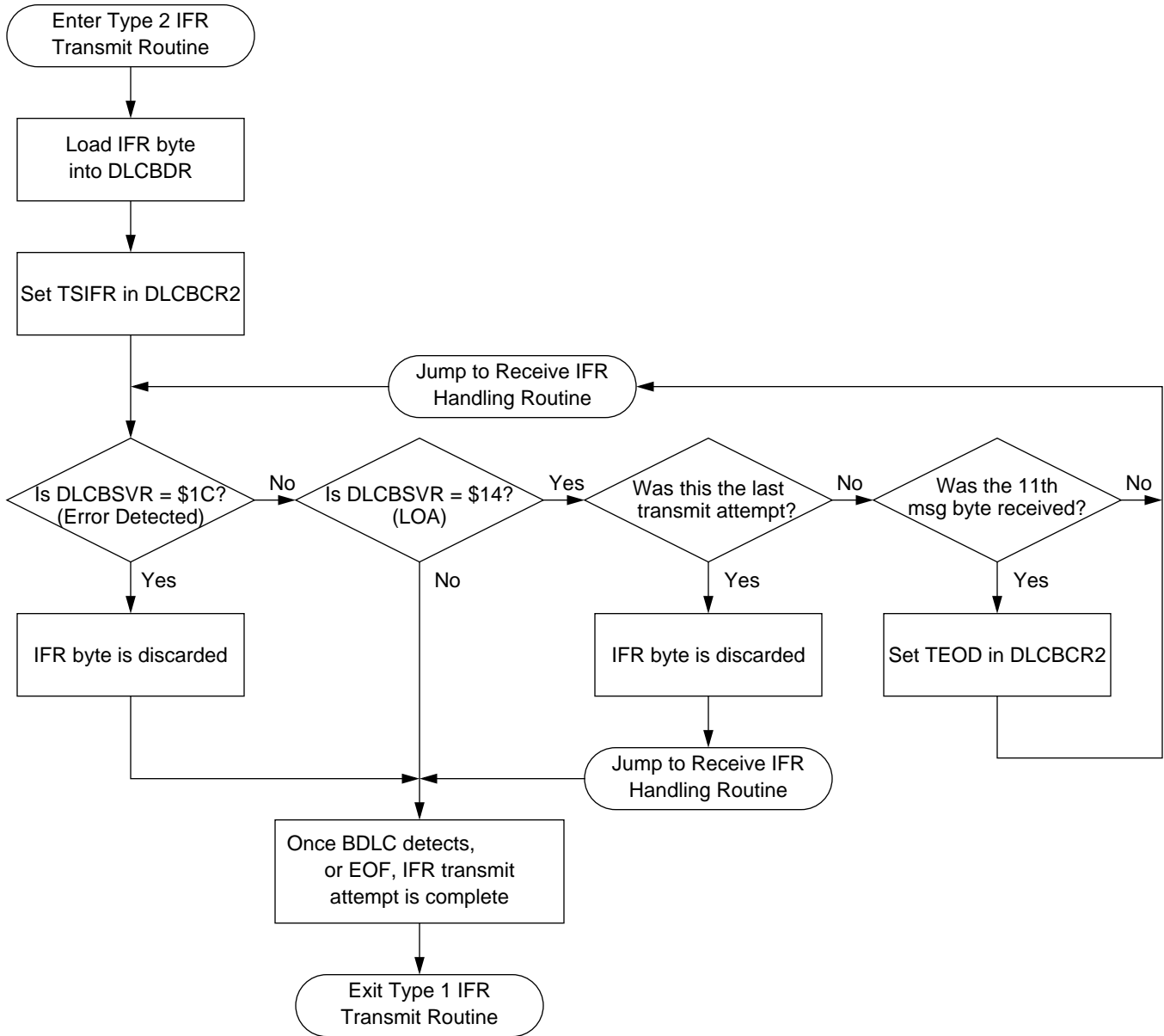

Figure 132 Transmitting A Type 2 IFR

Transmitting a Type 3 IFR

Transmitting a Type 3 IFR, with or without a CRC byte, is done in a fashion similar to transmitting a message frame. The user loads the first byte to be transmitted into the DLCBDR and then sets the appropriate TMIFR bit, depending upon whether a CRC byte is desired. When the

last byte is written to the BDR, the TEOD bit is set, and a CRC byte (if desired) and an EOD are then transmitted. Because the two versions of the Type 3 IFR are transmitted identically, the description which follows will discuss both. For an illustration of the Type 3 IFR transmit sequence, refer to [Transmitting A Type 3 IFR](#).

Step 1: Load the First IFR Byte into the DLCBDR

The user begins initiation of a Type 3 IFR, as with each of the other IFR types, by loading the desired IFR byte into the DLCBDR. If a byte has already been written into the DLCBDR for transmission as a new message, the user can simply write the first IFR byte to the DLCBDR, replacing the previously written byte. This must be done before the first EOD symbol is received.

Step 2: Set the TMIFR Bit

The second step necessary for transmitting a Type 3 IFR is to set the desired TMIFR bit in DLCBCR2, depending upon whether or not a CRC is desired. As previously described in [BDLC IFR Transmit Control Bits](#), the TMIFR1 bit should be set if the user requires a CRC byte to be appended following the last byte of the Type 3 IFR, and TMIFR0 if no CRC byte is required.

Setting the TMIFR1 or TMIFR0 bit will direct the BDLC to transmit the byte in the BDR as the first byte of a single or multi-byte IFR preceded by the appropriate Normalization Bit. Once this has occurred, the DLCBSVR will reflect that the next byte of the IFR can be written to the DLCBDR (TDRE interrupt).

The user must set the TMIFR1 or TMIFR0 bit before the EOD following the main part of the message frame is received, or no IFR transmit attempts will be made for the current message. If another node does transmit an IFR to this message or a reception error occurs, the TMIFR1 or TMIFR0 bit will be cleared. If not, the IFR will be transmitted after the EOD of the next received message.

Step 3: When TDRE is Indicated, Write the Next IFR Byte into the DLCBDR

When a TDRE state is reflected in the DLCBSVR, the CPU writes the next IFR byte to be transmitted into the DLCBDR, clearing the TDRE interrupt. This step is repeated until the last IFR byte to be transmitted is written to the DLCBDR.

NOTE: *As when transmitting a message, when transmitting a Type 3 IFR the user may write two, or possibly even three of the bytes to be transmitted into the DLCBDR before the first RxIFR interrupt occurs. For this reason, the user should never use receive IFR byte interrupts to control the sequencing of IFR bytes to be transmitted.*

Step 4: Write the Last IFR Byte into the DLCBDR and Set TEOD

Once the last IFR byte to be transmitted is written to the DLCBDR, the CPU then sets the TEOD bit in DLCBCR2. Once the TEOD bit is set, after the last IFR byte written to the DLCBDR is transmitted onto the bus, if the TMIFR1 bit has been set the BDLC will begin transmitting the CRC byte, followed by an EOD. If the TMIFR0 bit has been set, the last IFR byte will immediately be followed by the transmission of an EOD. Following the EOD, and EOF will be recognized and the message will be complete.

If at any time during the transmission of a Type 3 IFR a loss of arbitration occurs, the TMIFR bit which is set and the TEOD bit (if set) will be cleared, any IFR byte being transmitted will be discarded and the loss of arbitration state will be reflected in the DLCBSVR. Likewise, if an error is detected during the transmission of a Type 3 IFR the IFR control bits will be cleared, the byte being transmitted will be discarded and the DLCBSVR will reflect the detected error.

NOTE: *If the Type 3 IFR being transmitted is made up of a single byte, the appropriate TMIFR bit and the TEOD bit can be set at the same time. The BDLC will then treat that byte as both the first and last IFR byte to be sent.*

Transmitting IFR Exceptions

This basic IFR transmitting flow can be interrupted for the same reasons as a normal message transmission. The IFR transmit process can be adversely affected due to a loss of arbitration, an Invalid or Out of Range Symbol, or due to a transmitter underrun caused by the CPU failing to service a TDRE interrupt in a timely fashion. For a description of how these exceptions can affect the IFR transmit process, refer to [Transmitting Exceptions](#).

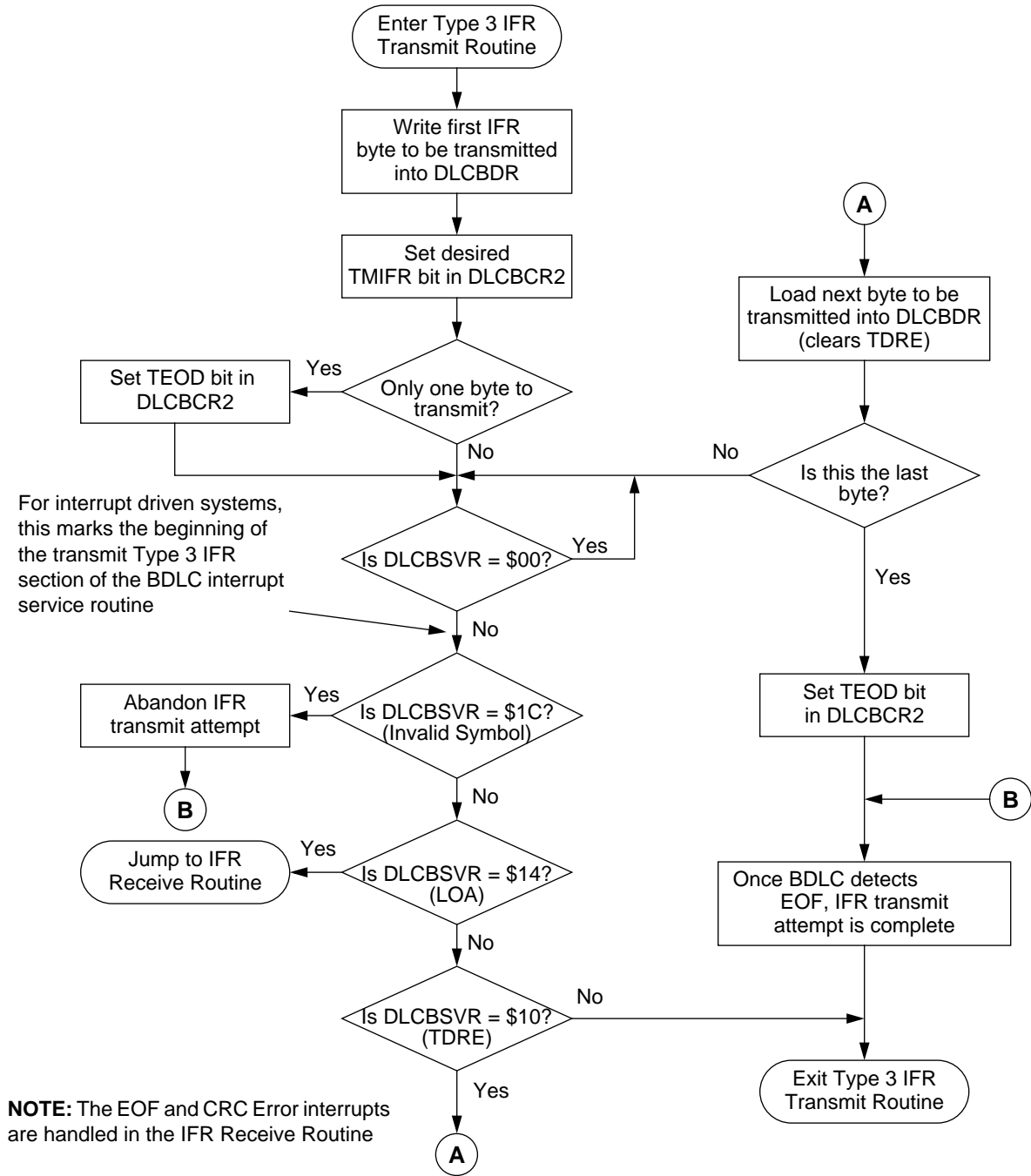

Figure 133 Transmitting A Type 3 IFR

Receiving An In-Frame Response (IFR)

Receiving an In-Frame Response with the BDLC is very similar to receiving a message frame. As each byte of an IFR is received, the DLCBSVR will indicate this to the CPU. An EOF indication in the DLCBSVR indicates that the IFR (and message) is complete. Also, the IMMSG bit can also be used to command the BDLC to mask any further network activity from the CPU, including IFR bytes being received, until the next valid SOF is received.

NOTE: *As with a message transmission, the IMMSG bit should never be used to ignore the BDLC's own IFR transmissions. This is again due to the DLCBSVR bits being inhibited from updating until IMMSG is cleared, preventing the CPU from detecting any IFR-related state changes which may be of interest.*

Receiving an IFR with the BDLC

Receiving an IFR from the SAE J1850 bus requires the same procedure that receiving a message does, except that as each byte is received the Received IFR Byte (RxIFR) state is indicated in the DLCBSVR. All other actions are the same. For an illustration of the steps described below, refer to [Receiving An IFR With the BDLC](#).

Step 1: When RxIFR Interrupt Occurs, Retrieve IFR Byte

When the first byte of an IFR following a valid EOD symbol is received that byte is placed in the DLCBDR, and an RxIFR state is reflected in the DLCBSVR. No indication of the EOD reception is made, since the RxIFR state will indicate that the main portion of the message has ended and the IFR portion has begun.

The RxIFR interrupt is cleared when the received IFR byte is read from the DLCBDR. Once this is done, no further CPU intervention is necessary until the next IFR byte is received, and this step is repeated. As with a message reception, all bytes of the IFR, including the CRC byte, will be placed into the DLCBDR as they are received for the CPU to retrieve.

Byte Data Link

When an EOF is Received, the IFR (and Message) is Complete

Once all IFR bytes (including the possible CRC byte) have been received from the bus, the bus will again be idle for a time period equal to an EOD symbol. Following this, the BDLC will determine whether or not the last byte of the IFR is a CRC byte, and if so verify that the CRC byte is correct. If the CRC byte is not correct, this will be reflected in the DLCBSVR.

After an additional period of time the EOD symbol will transition into an EOF symbol. When the EOF is received it will be reflected in the DLCBSVR, indicating to the user that the IFR, and the message, is complete.

Freescale Semiconductor, Inc.

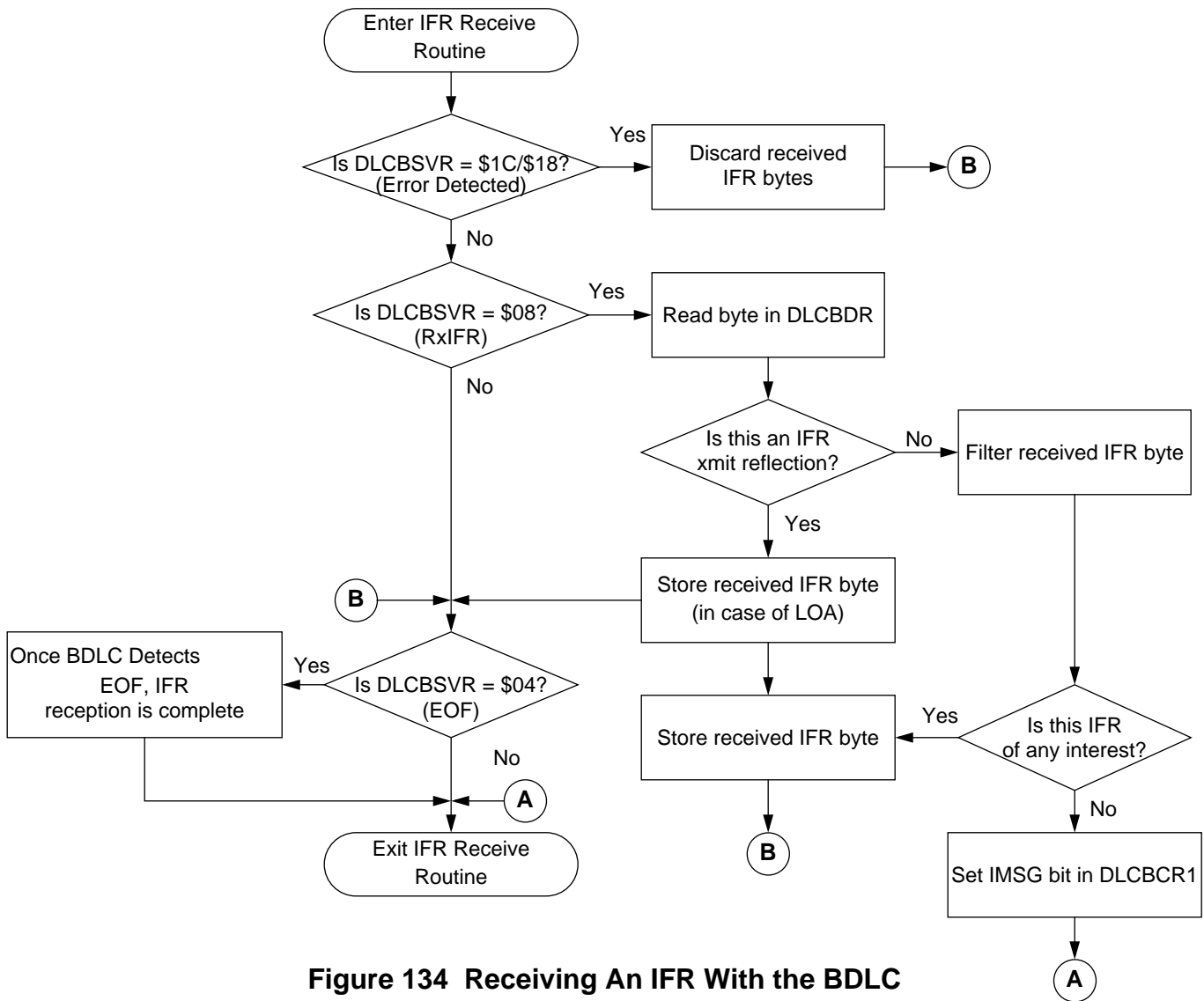

Figure 134 Receiving An IFR With the BDLC

Receiving IFR Exceptions

This basic IFR receiving flow can be interrupted for the same reasons as a normal message reception. The IFR receiving process can be adversely affected due to a CRC error, an Invalid or Out of Range Symbol or due to a receiver overrun caused by the CPU failing to service an RxIFR interrupt in a timely fashion. For a description of how these exceptions can affect the IFR receiving process, refer to [Receiving Exceptions](#).

Special BDLC Operations

There are a few special operations which the BDLC can perform. What follows is a brief description of each of these functions and when they might be used.

Transmitting Or Receiving A Block Mode Message

The BDLC, because it handles each message on a byte-by-byte basis, has the inherent capability of handling messages any number of bytes in length. While during normal operation this requires the user to carefully monitor message lengths to ensure compliance with SAE J1850 message limits, often in a production or diagnostic environment messages which exceed the SAE J1850 limits can be beneficial. This is especially true when large amounts of configuration data need to be downloaded over the SAE J1850 network.

Because of the BDLC's architecture, it can both transmit and receive messages of unlimited length. The CRC calculations, both for transmitting and receiving, are not limited to eight bytes, but will instead be calculated and verified using all bytes in the message, regardless of the number. All control bits, including TEOD and IMSG, also work in an identical manner, regardless of the length of the message.

To transmit or receive these "Block Mode" messages, no extra BDLC control functions must be performed. The user simply transmits or receives as many bytes as desired in one message frame, and the BDLC will operate just as if a message of normal length was being used.

**Receiving A
Message In 4X
Mode**

In a diagnostic or production environment large amounts of data may need to be downloaded across the network to a component or module. This data is often sent in a large “Block Mode” message (see above) which violates the SAE J1850 limit for message length. In order to speed up the downloading of these large blocks of data, they are sometimes transmitted at four times (4X) the normal bit rate for the Variable Pulse Width modulation version of SAE J1850. This higher speed transmission, nominally 41.6kbps, allows these large blocks to be transmitted much more quickly.

The BDLC is designed to receive (but not transmit) messages transmitted at this higher speed. By setting the RX4XE bit in DLCBCR2, the user can command the BDLC to receive any message sent over the network at a 4X rate.

If the BDLC is placed in this 4X mode, messages transmitted at the normal bit rate will not be received correctly. Likewise, 4X messages transmitted on the SAE J1850 bus when the BDLC is in normal mode will be interpreted as noise on the network by the BDLC. The RX4XE bit is not affected by entry or exit from BDLC stop or wait modes. For more information on the RX4XE bit, refer to [RX4XE — Receive 4X Enable \(Bit 5\)](#).

Modes of Operation

The BDLC has 6 main modes of operation which interact with the power supplies, pins, and the rest of the MCU as shown below. The operation of the BDLC in Normal and Special Modes are described later in this section.

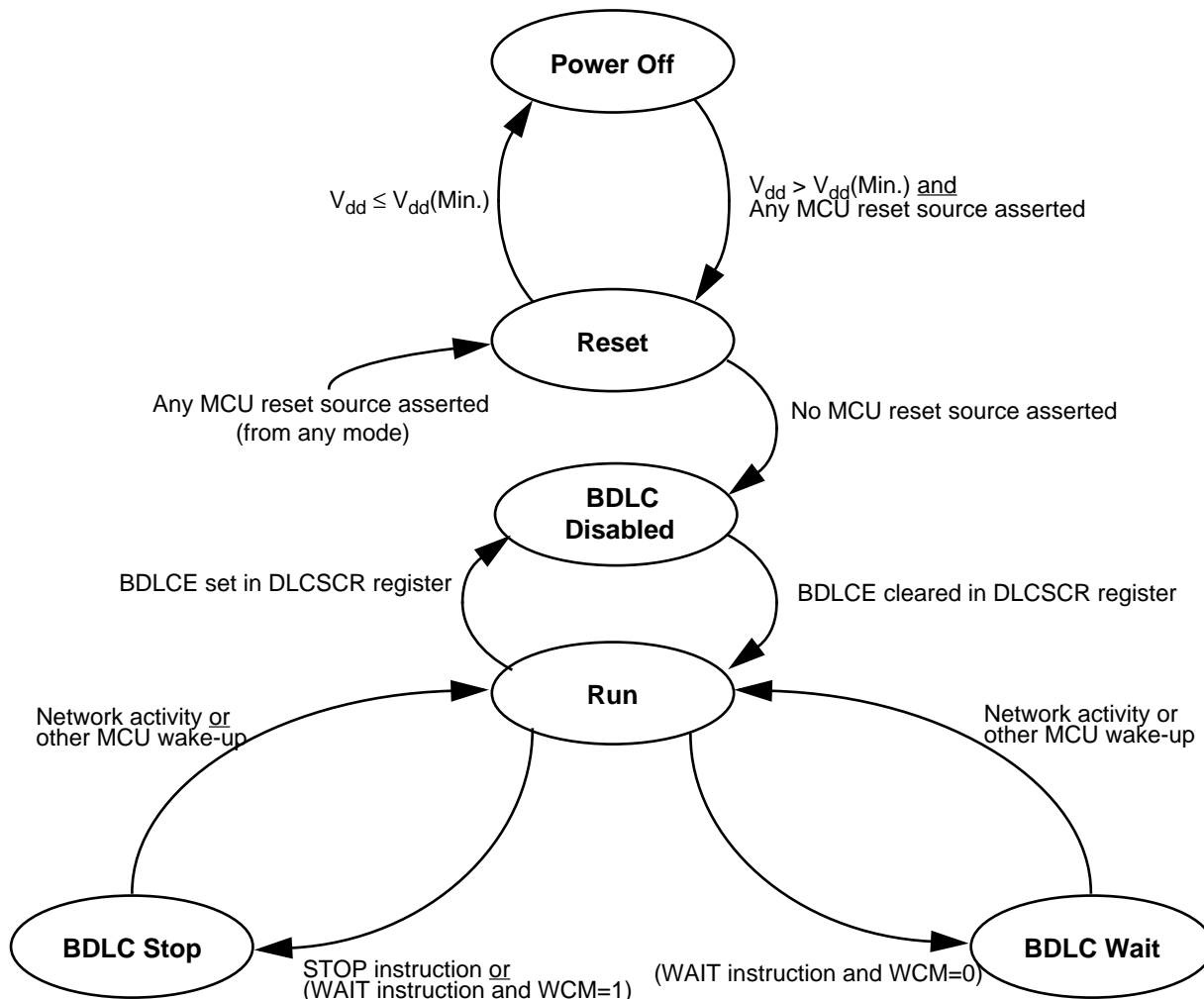

Figure 135 BDLC Operating Modes State Diagram

Power Off

This mode is entered from the Reset mode whenever the BDLC supply voltage V_{dd} drops below its minimum specified value for the BDLC to guarantee operation. The BDLC will be placed in the Reset mode by a system Low Voltage Reset (LVR) before being powered down. In this mode, the pin input and output specifications are not guaranteed.

Reset

This mode is entered from the Power Off mode whenever the BDLC supply voltage V_{dd} rises above its minimum specified value ($V_{dd(MIN)}$)

and some MCU reset source is asserted. To prevent the BDLC from entering an unknown state, the internal MCU reset is asserted while powering up the BDLC. BDLC Reset mode is also entered from any other mode as soon as one of the MCU's possible reset sources (e.g. LVR, POR, COP watchdog, Reset pin etc.) is asserted.

In this mode, the internal BDLC voltage references are operative, V_{dd} is supplied to the internal circuits, which are held in their reset state and the internal BDLC system clock is running. Registers will assume their reset condition. Outputs are held in their programmed Reset state, inputs and network activity are ignored.

BDLC Disabled

This mode is entered from the Reset mode after all MCU reset sources are no longer asserted. It is entered from the Run mode whenever the BDLCE bit in the DLCSCR register is cleared.

In this mode the mux interface clock (f_{bdlc}) is stopped to conserve power and allow the BDLC to be configured for proper operation on the J1850 bus. The IP bus interface clocks are left running in this mode to allow access to all BDLC registers for initialization.

Run

This mode is entered from the BDLC Disabled mode when the BDLCE bit in the DLCSCR register is set. It is entered from the BDLC Wait mode whenever activity is sensed on the J1850 bus or some other MCU source wakes the CPU out of Wait mode.

It is entered from the BDLC Stop mode whenever network activity is sensed or some other MCU source wakes the CPU out of Stop mode. Messages will not be received properly until the clocks have stabilized and the CPU is also in the Run mode.

In this mode, normal network operation takes place. The user should ensure that all BDLC transmissions have ceased, by reading the IDLE bit in the DLCBSTAT register, before exiting this mode.

BDLC Wait

This power conserving mode is automatically entered from the Run mode whenever the CPU executes a WAIT instruction and if the WCM

bit in the DLCBCR1 register is previously cleared. In this mode, the BDLC internal clocks continue to run. Any activity on the J1850 network will cause the BDLC to exit BDLC Wait mode and generate an unmaskable interrupt of the CPU. This Wakeup interrupt state is reflected in the DLCBSVR, encoded as the highest priority interrupt. This interrupt can be cleared by the CPU with a read of the DLCBSVR.

*Wakeup from
BDLC Wait with
CPU in WAIT*

If the CPU executes the WAIT instruction and the BDLC enters the WAIT mode (WCM = 0), the clocks to the BDLC as well as the clocks in the MCU continue to run. Therefore, the message which wakes up the BDLC from WAIT and the CPU from WAIT mode will also be received correctly by the BDLC. This is because all of the required clocks continue to run in the BDLC in WAIT mode. The wakeup behavior of the BDLC applies regardless of whether the BDLC is in normal or 4X mode when the WAIT instruction is executed.

BDLC Stop

This power conserving mode is automatically entered from the Run mode whenever the CPU executes a STOP instruction, or if the CPU executes a WAIT instruction and the WCM bit in the DLCBCR1 register is previously set. In this mode, the BDLC internal clocks are stopped. Any activity on the network will cause the BDLC to exit BDLC Stop mode and generate an unmaskable interrupt of the CPU. This Wakeup interrupt state is reflected in the DLCBSVR, encoded as the highest priority interrupt. This interrupt can be cleared by the CPU with a read of the DLCBSVR. Depending upon which low-power mode instruction the CPU executes to cause the BDLC to enter BDLC Stop, the message which wakes up the BDLC (and the CPU) may or may not be received. There are two different possibilities, both of which is described below. These descriptions apply regardless of whether the BDLC is in normal or 4X mode when the STOP or WAIT instruction is executed.

*Wakeup from
BDLC Stop with
CPU in STOP*

When the CPU executes the STOP instruction, all clocks in the MCU, including clocks to the BDLC, are turned off. Therefore, the message which wakes up the BDLC and the CPU from STOP mode will not be received. This is due primarily to the amount of time required for the MCU's oscillator to stabilize before the clocks can be applied internally to the other MCU modules, including the BDLC.

Byte Data Link

*Wakeup from
BDLC Stop with
CPU in WAIT*

If the CPU executes the WAIT instruction and the BDLC enters the Stop mode (WCM = 1), the clocks to the BDLC are turned off, but the clocks in the MCU continue to run. Therefore, the message which wakes up the BDLC from Stop and the CPU from WAIT mode will be received correctly by the BDLC. This is because very little time is required for the CPU to turn the clocks to the BDLC back on once the Wakeup interrupt occurs.

NOTE: *While the BDLC will correctly receive a message which arrives when the BDLC is in Stop mode or Wait mode and the MCU is in WAIT mode, if the user enters this mode while a message is being received, the data in the message will become corrupted. This is due to the steps required for the BDLC to resume operation upon exiting Stop mode or Wait mode, and its subsequent resynchronization with the SAE J1850 bus.*

Digital Loopback

When a bus fault has been detected, the digital loopback mode is used to determine if the fault condition is caused by failure in the node's internal circuits or elsewhere in the network, including the node's analog physical interface. In this mode, the input to the digital filter is disconnected from the receive pin input (RxP). The input to the digital filter is then connected to the transmitter output to form the loopback connection. The transmit pin (TxP) is negated and will always drive a passive state onto the bus. Digital loopback mode is entered by setting the DLOOP bit in [BDLC Control Register 2 \(DLCBCR2\)](#).

Normal and Emulation Mode Operation

The BDLC operates in the same manner in all Normal and Emulation Modes. All BDLC registers can be read and written except those that are reserved, unimplemented, or write once. The user must be careful not to unintentionally write a register when using 16-bit writes in order to avoid unexpected BDLC behavior.

Special Mode Operation

Some aspects of BDLC operation can be modified in special test mode. This mode is reserved for internal use only.

Interrupt Operation

The BDLC will generate an Interrupt Request to the CPU when a BDLC interrupt source is pending in the DLCBSVR. All DLCBSVR interrupts except the Wakeup Interrupt (DLCBSVR=\$20) can be masked by clearing the IE bit in DLCBCR1. Refer to [BDLC State Vector Register \(DLCBSVR\)](#) for a description of the BDLC interrupt sources and how to service them.

Low Power Options

The BDLC can save power in Disabled, Wait, and Stop modes. A complete description of what the BDLC does while in a low power mode can be found in [Modes of Operation](#).



Background Debug Module (BDM)

Contents

Overview	691
Interface Signals	692
Registers	693
Operation	698
Modes of Operation	710
Low-Power Options	711
Interrupt Operation	711

Overview

The Background Debug Mode (BDM) sub-block is a single-wire, background debug system implemented in on-chip hardware for minimal CPU intervention. All interfacing with the BDM is done via the BKGD pin.

Features

- Single-wire communication with host development system
- Active out of reset in special single-chip mode
- Nine hardware commands using free cycles, if available, for minimal CPU intervention
- Hardware commands not requiring active BDM
- 15 firmware commands execute from the standard BDM firmware lookup table
- Instruction tagging capability
- Software control of BDM operation during wait mode
- Software selectable clocks

Background Debug Module

- BDM disabled when secure feature is enabled

Block Diagram

The block diagram of the BDM is shown in Figure 136 below.

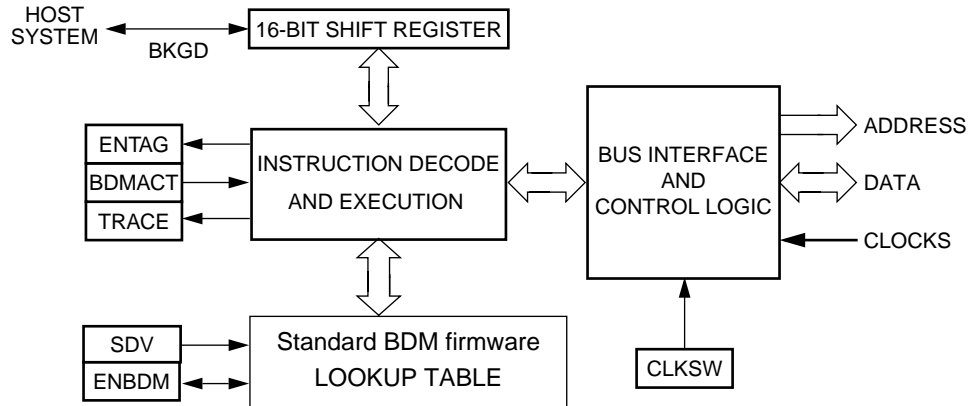

Figure 136 BDM Block Diagram

Interface Signals

A single-wire interface pin is used to communicate with the BDM system. Two additional pins are used for instruction tagging.

- BKGD — Background interface pin
- TAGHI — High byte instruction tagging pin
- TAGLO — Low byte instruction tagging pin

BKGD and TAGHI share the same pin. TAGLO and LSTRB share the same pin.

Background Interface Pin (BKGD)

Debugging control logic communicates with external devices serially via the single-wire background interface pin (BKGD). During reset, this pin is a mode select input which selects between normal and special modes of operation. After reset, this pin becomes the dedicated serial interface pin for the background debug mode.

High Byte Instruction Tagging Pin (TAGHI)

This pin is used to tag the high byte of an instruction. When instruction tagging is on, a logic 0 at the falling edge of the external clock (ECLK) tags the high half of the instruction word being read into the instruction queue.

Low Byte Instruction Tagging Pin (TAGLO)

This pin is used to tag the low byte of an instruction. When instruction tagging is on and low strobe is enabled, a logic 0 at the falling edge of the external clock (ECLK) tags the low half of the instruction word being read into the instruction queue.

Registers

A summary of the registers associated with the BDM is shown in [Figure 137](#) below. Registers are accessed by host-driven communications to the BDM hardware using READ_BD and WRITE_BD commands. Detailed descriptions of the registers and associated bits are given in the subsections that follow.

Address	Register Name		Bit 7	6	5	4	3	2	1	Bit 0
\$FF00	BDM reserved	Read:	X	X	X	X	X	X	0	0
		Write:								
\$FF01	BDMSTS	Read:	ENBDM	BDMACT	ENTAG	SDV	TRACE	CLKSW	UNSEC	0
		Write:								
\$FF02	BDM reserved	Read:	X	X	X	X	X	X	X	X
		Write:								
\$FF03	BDM reserved	Read:	X	X	X	X	X	X	X	X
		Write:								
\$FF04	BDM reserved	Read:	X	X	X	X	X	X	X	X
		Write:								
\$FF05	BDM reserved	Read:	X	X	X	X	X	X	X	X
		Write:								

= Unimplemented X = Indeterminate

Background Debug Module

Address	Register Name		Bit 7	6	5	4	3	2	1	Bit 0
\$FF06	BDMCCR	Read:	CCR7	CCR6	CCR5	CCR4	CCR3	CCR2	CCR1	CCR0
		Write:								
\$FF07	BDMINR	Read:	REG15	REG14	REG13	REG12	REG11	0	0	0
		Write:								

= Unimplemented X = Indeterminate

Figure 137 BDM Register Map Summary

BDM Status Register (BDMSTS)

Address: \$FF01

	Bit 7	6	5	4	3	2	1	Bit 0
Read:	ENBDM	BDMACT	ENTAG	SDV	TRACE	CLKSW	UNSEC	0
Write:								
Reset:								
Special single-chip mode:	0	1	0	0	0	0	0	0
Special peripheral mode:	0	1	0	0	0	0	0	0
All other modes:	0	0	0	0	0	0	0	0

= Unimplemented

Read: All modes through BDM operation

Write: All modes but subject to the following:

- BDMACT can only be set by BDM hardware upon entry into BDM. It can only be cleared by the standard BDM firmware lookup table upon exit from BDM active mode.
- CLKSW can only be written via BDM hardware or standard BDM firmware write commands.
- All other bits, while writable via BDM hardware or standard BDM firmware write commands, should only be altered by the BDM hardware or standard firmware lookup table as part of BDM command execution.

- ENBDM should only be set via a BDM hardware command if the BDM firmware commands are needed. (This does not apply in Special Single Chip Mode).

ENBDM — Enable BDM

This bit controls whether the BDM is enabled or disabled. When enabled, BDM can be made active to allow firmware commands to be executed. When disabled, BDM cannot be made active but BDM hardware commands are still allowed.

1 = BDM enabled

0 = BDM disabled

NOTE: *ENBDM is set by the firmware immediately out of reset in special single-chip mode.*

BDMACT — BDM active status

This bit becomes set upon entering BDM. The standard BDM firmware lookup table is then enabled and put into the memory map. BDMACT is cleared by a carefully timed store instruction in the standard BDM firmware as part of the exit sequence to return to user code and remove the BDM memory from the map.

1 = BDM active

0 = BDM not active

ENTAG — Tagging enable

This bit indicates whether instruction tagging is enabled or disabled. It is set when the TAGGO command is executed and cleared when BDM is entered. The serial system is disabled and the tag function enabled 16 cycles after this bit is written. BDM cannot process serial commands while tagging is active.

1 = Tagging enabled

0 = Tagging not enabled, or BDM active

SDV — Shift data valid

This bit is set and cleared by the BDM hardware. It is set after data has been transmitted as part of a firmware read command or after data has been received as part of a firmware write command. It is

cleared when the next BDM command has been received or BDM is exited. SDV is used by the standard BDM firmware to control program flow execution.

- 1 = Data phase of command is complete
- 0 = Data phase of command not complete

TRACE — TRACE1 BDM firmware command is being executed

This bit gets set when a BDM TRACE1 firmware command is first recognized. It will stay set as long as continuous back-to-back TRACE1 commands are executed. This bit will get cleared when the next command that is not a TRACE1 command is recognized.

- 1 = TRACE1 command is being executed
- 0 = TRACE1 command is not being executed

CLKSW — Clock switch

The CLKSW bit controls which clock the BDM operates with. It is only writable from a hardware BDM command. A 150 cycle delay at the clock speed that is active during the data portion of the command will occur before the new clock source is guaranteed to be active. The start of the next BDM command uses the new clock for timing subsequent BDM communications.

- 1 = BDM system operates with bus rate
- 0 = BDM system operates with alternate clock

WARNING: *Care must be taken when CLKSW=0 to ensure that the alternate clock frequency does not exceed that of the bus clock frequency. The BDM will not operate correctly if this condition exists.*

UNSEC — Unsecure

This bit is only writable in special single chip mode from a hardware BDM command and always gets reset to zero. It is in a zero state as secure mode is entered so that the secure BDM firmware lookup table is enabled and put into the memory map along with the standard BDM firmware lookup table.

The secure BDM firmware lookup table verifies that the on-chip EEPROM and Flash EEPROM are erased. This being the case, the UNSEC bit is set and the BDM program jumps to the start of the standard BDM firmware lookup table and the secure BDM firmware lookup table is turned off.

- 1 = the system is in a unsecured mode
- 0 = the system is in a secured mode

WARNING: *When UNSEC is set, security is off and the user can change the state of the secure bits in the on-chip Flash EEPROM. Note that if the user does not change the state of the bits to “unsecured” mode, the system will be secured again when it is next taken out of reset.*

BDM CCR Holding Register (BDMCCR)

Address: \$FF06

	Bit 7	6	5	4	3	2	1	Bit 0
Read:	CCR7	CCR6	CCR5	CCR4	CCR3	CCR2	CCR1	CCR0
Write:								
Reset:	0	0	0	0	0	0	0	0

Read: All modes
Write: All modes

NOTE: *When BDM is made active, the CPU stores the value of the CCR register in the BDMCCR register. However, out of special single-chip reset, the BDMCCR is set to \$D8 and not \$D0 which is the reset value of the CCR register.*

When entering background debug mode, the BDM CCR holding register is used to save the contents of the condition code register of the user’s program. It is also used for temporary storage in the standard BDM firmware mode. The BDM CCR holding register can be written to modify the CCR value.

Background Debug Module

BDM Internal Register Position Register (BDMINR)

Address: \$FF07

	Bit 7	6	5	4	3	2	1	Bit 0
Read:	REG15	REG14	REG13	REG12	REG11	0	0	0
Write:								
Reset:	0	0	0	0	0	0	0	0

 = Unimplemented

Read: All modes

Write: Never

REG15–REG11 — Internal register map position

These five bits show the state of the upper five bits of the base address for the system’s relocatable register block. BDMINR is a shadow of the INITRG register which maps the register block to any 2K byte space within the first 32K bytes of the 64K byte address space.

Operation

The BDM receives and executes commands from a host via a single wire serial interface. There are two types of BDM commands, namely, hardware commands and firmware commands.

Hardware commands are used to read and write target system memory locations and to enter active background debug mode (see [BDM Hardware Commands](#)). Target system memory includes all memory that is accessible by the CPU.

Firmware commands are used to read and write CPU resources and to exit from active background debug mode (see [Standard BDM Firmware Commands](#)). The CPU resources referred to are the accumulator (D), X index register (X), Y index register (Y), stack pointer (SP), and program counter (PC).

Hardware commands can be executed at any time and in any mode excluding a few exceptions as highlighted in [Modes of Operation](#) below. Firmware commands can only be executed when the system is in active background debug mode (BDM).

Security

If the user resets into special single chip mode with the system secured, a SECURE BDM FIRMWARE lookup table is brought into the map overlapping a portion of the STANDARD BDM FIRMWARE lookup table. The secure BDM firmware verifies that the on-chip EEPROM and Flash EEPROM are erased. This being the case, the UNSEC bit will get set. The BDM program jumps to the start of the standard BDM firmware and the secure BDM firmware is turned off.

Enabling and Activating BDM

The system must be in active BDM to execute standard BDM firmware commands. BDM can be activated only after being enabled. BDM is enabled by setting the ENBDM bit in the BDM status (BDMSTS) register. The ENBDM bit is set by writing to the BDM status (BDMSTS) register, via the single-wire interface, using a hardware command such as WRITE_BD_BYTE.

After being enabled, BDM is activated by one of the following¹:

- Hardware BACKGROUND command
- BDM external instruction tagging mechanism
- CPU BGND instruction
- Breakpoint sub-block's force or tag mechanism²

When BDM is activated, the CPU finishes executing the current instruction and then begins executing the firmware in the standard BDM firmware lookup table. When BDM is activated by the breakpoint sub-block, the type of breakpoint used determines if BDM becomes active before or after execution of the next instruction.

1. BDM is enabled and active immediately out of special single-chip reset (see [Special Operation](#)).

2. This method is only available on systems that have a a Breakpoint sub-block.

Background Debug Module

NOTE: *If an attempt is made to activate BDM before being enabled, the CPU resumes normal instruction execution after a brief delay. If BDM is not enabled, any hardware BACKGROUND commands issued are ignored by the BDM and the CPU is not delayed.*

In active BDM, the BDM registers and standard BDM firmware lookup table are mapped to addresses \$FF00 to \$FFFF. BDM registers are mapped to addresses \$FF00 to \$FF07. The BDM uses these registers which are readable anytime by the BDM. These registers are not, however, readable by user programs.

BDM Hardware Commands

Hardware commands are used to read and write target system memory locations and to enter active background debug mode. Target system memory includes all memory that is accessible by the CPU such as on-chip RAM, EEPROM, Flash EEPROM, I/O and control registers, and all external memory.

Hardware commands are executed with minimal or no CPU intervention and do not require the system to be in active BDM for execution, although, they can still be executed in this mode. When executing a hardware command, the BDM sub-block waits for a free CPU bus cycle so that the background access does not disturb the running application program. If a free cycle is not found within 128 clock cycles, the CPU is momentarily frozen so that the BDM can steal a cycle. When the BDM finds a free cycle, the operation does not intrude on normal CPU operation provided that it can be completed in a single cycle. However, if an operation requires multiple cycles, the CPU is frozen until the operation is complete, even though the BDM found a free cycle.

The BDM hardware commands are listed in [Table 121](#).

Table 121 Hardware Commands

Command	Opcode (hex)	Data	Description
BACKGROUND	90	None	Enter background mode if firmware is enabled.
READ_BD_BYTE	E4	16-bit address 16-bit data out	Read from memory with standard BDM firmware lookup table in map. Odd address data on low byte; even address data on high byte
READ_BD_WORD	EC	16-bit address 16-bit data out	Read from memory with standard BDM firmware lookup table in map. Must be aligned access.
READ_BYTE	E0	16-bit address 16-bit data out	Read from memory with standard BDM firmware lookup table out of map. Odd address data on low byte; even address data on high byte
READ_WORD	E8	16-bit address 16-bit data out	Read from memory with standard BDM firmware lookup table out of map. Must be aligned access.
WRITE_BD_BYTE	C4	16-bit address 16-bit data in	Write to memory with standard BDM firmware lookup table in map. Odd address data on low byte; even address data on high byte
WRITE_BD_WORD	CC	16-bit address 16-bit data in	Write to memory with standard BDM firmware lookup table in map. Must be aligned access
WRITE_BYTE	C0	16-bit address 16-bit data in	Write to memory with standard BDM firmware lookup table out of map. Odd address data on low byte; even address data on high byte
WRITE_WORD	C8	16-bit address 16-bit data in	Write to memory with standard BDM firmware lookup table out of map. Must be aligned access.

The READ_BD and WRITE_BD commands allow access to the BDM register locations. These locations are not normally in the system memory map but share addresses with the application in memory. To distinguish between physical memory locations that share the same address, BDM memory resources are enabled just for the READ_BD and WRITE_BD access cycle. This allows the BDM to access BDM locations unobtrusively, even if the addresses conflict with the application memory map.

**Standard BDM
Firmware
Commands**

Firmware commands are used to access and manipulate CPU resources. The system must be in active BDM to execute standard BDM firmware commands (see [Enabling and Activating BDM](#)). Normal

Background Debug Module

instruction execution is suspended while the CPU executes the firmware located in the standard BDM firmware lookup table. The hardware command BACKGROUND is the usual way to activate BDM.

As the system enters active BDM, the standard BDM firmware lookup table and BDM registers become visible in the on-chip memory map at \$FF00-\$FFFF, and the CPU begins executing the standard BDM firmware. The standard BDM firmware watches for serial commands and executes them as they are received. The firmware commands are shown in [Table 122](#).

Table 122 Firmware Commands

Command	Opcode (hex)	Data	Description
READ_NEXT	62	16-bit data out	Increment X by 2 ($X = X + 2$), then read word X points to.
READ_PC	63	16-bit data out	Read program counter.
READ_D	64	16-bit data out	Read D accumulator.
READ_X	65	16-bit data out	Read X index register.
READ_Y	66	16-bit data out	Read Y index register.
READ_SP	67	16-bit data out	Read stack pointer.
WRITE_NEXT	42	16-bit data in	Increment X by 2 ($X=X+2$), then write word to location pointed to by X.
WRITE_PC	43	16-bit data in	Write program counter.
WRITE_D	44	16-bit data in	Write D accumulator.
WRITE_X	45	16-bit data in	Write X index register.
WRITE_Y	46	16-bit data in	Write Y index register.
WRITE_SP	47	16-bit data in	Write stack pointer.
GO	08	none	Go to user program.
TRACE1	10	none	Execute one user instruction then return to active BDM.
TAGGO	18	none	Enable tagging and go to user program.

BDM Command Structure

Hardware and firmware BDM commands start with an 8-bit opcode followed by a 16-bit address and/or a 16-bit data word depending on the command. All the read commands return 16 bits of data despite the byte or word implication in the command name.

NOTE: *8-bit reads return 16-bits of data, of which, only one byte will contain valid data. If reading an even address, the valid data will appear in the MSB. If reading an odd address, the valid data will appear in the LSB.*

NOTE: *16-bit misaligned reads and writes are not allowed. If attempted, the BDM will ignore the least significant bit of the address and will assume an even address from the remaining bits.*

For hardware data read commands, the external host must wait 150 target clock cycles¹ after sending the address before attempting to obtain the read data. This is to be certain that valid data is available in the BDM shift register, ready to be shifted out. For hardware write commands, the external host must wait 150 target clock cycles after sending the data to be written before attempting to send a new command. This is to avoid disturbing the BDM shift register before the write has been completed. The 150 target clock cycle delay in both cases includes the maximum 128 cycle delay that can be incurred as the BDM waits for a free cycle before stealing a cycle.

For firmware read commands, the external host must wait 32 target clock cycles after sending the command opcode before attempting to obtain the read data. This allows enough time for the requested data to be made available in the BDM shift register, ready to be shifted out. For firmware write commands, the external host must wait 32 target clock cycles after sending the data to be written before attempting to send a new command. This is to avoid disturbing the BDM shift register before the write has been completed.

The external host should wait 64 target clock cycles after a TRACE1 or GO command before starting any new serial command. This is to allow the CPU to exit gracefully from the standard BDM firmware lookup table

1. Target clock cycles are cycles measured using the target system's serial clock rate. See [BDM Serial Interface](#) and [BDM Status Register \(BDMSTS\)](#) for information on how serial clock rate is selected.

Background Debug Module

and resume execution of the user code. Disturbing the BDM shift register prematurely may adversely affect the exit from the standard BDM firmware lookup table.

Figure 138 represents the BDM command structure. The command blocks illustrate a series of eight bit times starting with a falling edge. The bar across the top of the blocks indicates that the BKGD line idles in the high state. The time for an 8-bit command is 8×16 target clock cycles.

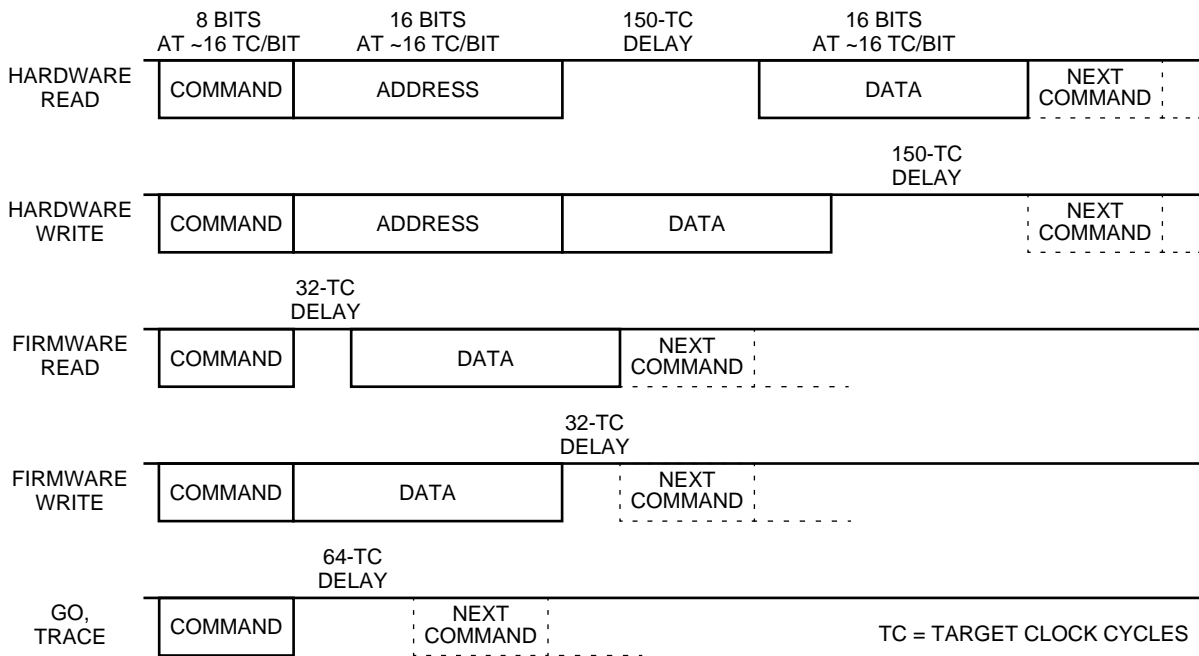

Figure 138 BDM Command Structure

BDM Serial Interface

The BDM communicates with external devices serially via the BKGD pin. During reset, this pin is a mode select input which selects between normal and special modes of operation. After reset, this pin becomes the dedicated serial interface pin for the BDM.

The BDM serial interface is timed using the clock selected by the CLKSW bit in the status register (see [BDM Status Register \(BDMSTS\)](#)). This clock will be referred to as the target clock in the following explanation.

The BDM serial interface uses a clocking scheme in which the external host generates a falling edge on the BKGD pin to indicate the start of each bit time. This falling edge is sent for every bit whether data is transmitted or received. Data is transferred most significant bit (MSB) first at 16 target clock cycles per bit. The interface times out if 512 clock cycles occur between falling edges from the host.

The BKGD pin is a pseudo open-drain pin and has an weak on-chip active pull-up that is enabled at all times. It is assumed that there is an external pullup and that drivers connected to BKGD do not typically drive the high level. Since R-C rise time could be unacceptably long, the target system and host provide brief driven-high (speedup) pulses to drive BKGD to a logic 1. The source of this speedup pulse is the host for transmit cases and the target for receive cases.

The timing for host-to-target is shown in [Figure 139](#) and that of target-to-host in [Figure 140](#) and [Figure 141](#) below. All four cases begin when the host drives the BKGD pin low to generate a falling edge. Since the host and target are operating from separate clocks, it can take the target system up to one full clock cycle to recognize this edge. The target measures delays from this perceived start of the bit time while the host measures delays from the point it actually drove BKGD low to start the bit up to one target clock cycle earlier. Synchronization between the host and target is established in this manner at the start of every bit time.

[Figure 139](#) shows an external host transmitting a logic 1 and transmitting a logic 0 to the BKGD pin of a target system. The host is asynchronous to the target, so there is up to a one clock-cycle delay from the host-generated falling edge to where the target recognizes this edge as the beginning of the bit time. Ten target clock cycles later, the target senses the bit level on the BKGD pin. Internal glitch detect logic requires the pin be driven high no later that eight target clock cycles after the falling edge for a logic 1 transmission.

Since the host drives the high speedup pulses in these two cases, the rising edges look like digitally driven signals.

Background Debug Module

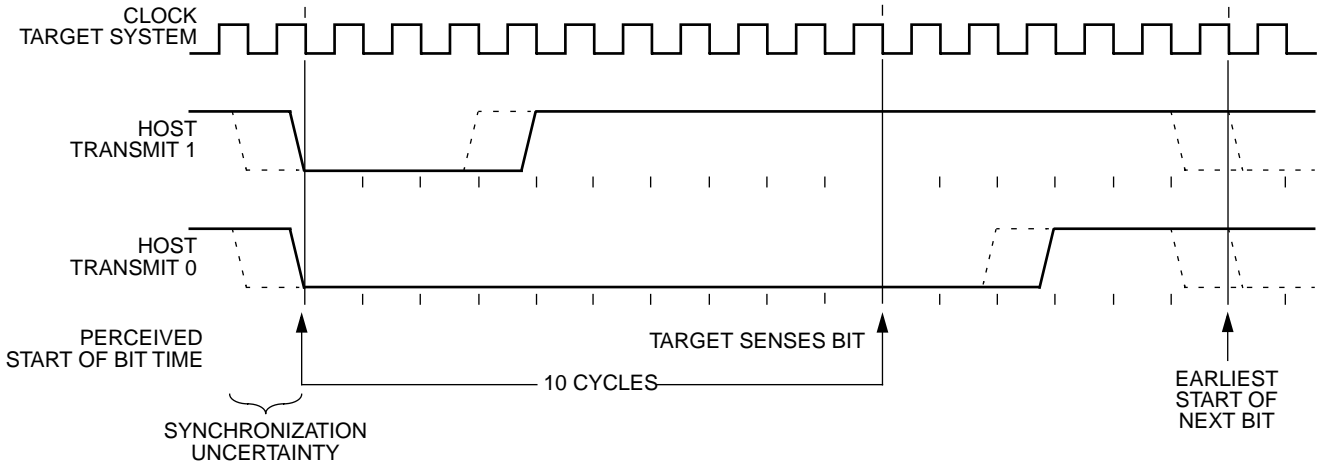

Figure 139 BDM Host-to-Target Serial Bit Timing

The receive cases are more complicated. [Figure 140](#) shows the host receiving a logic 1 from the target system. Since the host is asynchronous to the target, there is up to one clock-cycle delay from the host-generated falling edge on BKGD to the perceived start of the bit time in the target. The host holds the BKGD pin low long enough for the target to recognize it (at least two target clock cycles). The host must release the low drive before the target drives a brief high speedup pulse seven target clock cycles after the perceived start of the bit time. The host should sample the bit level about 10 target clock cycles after it started the bit time.

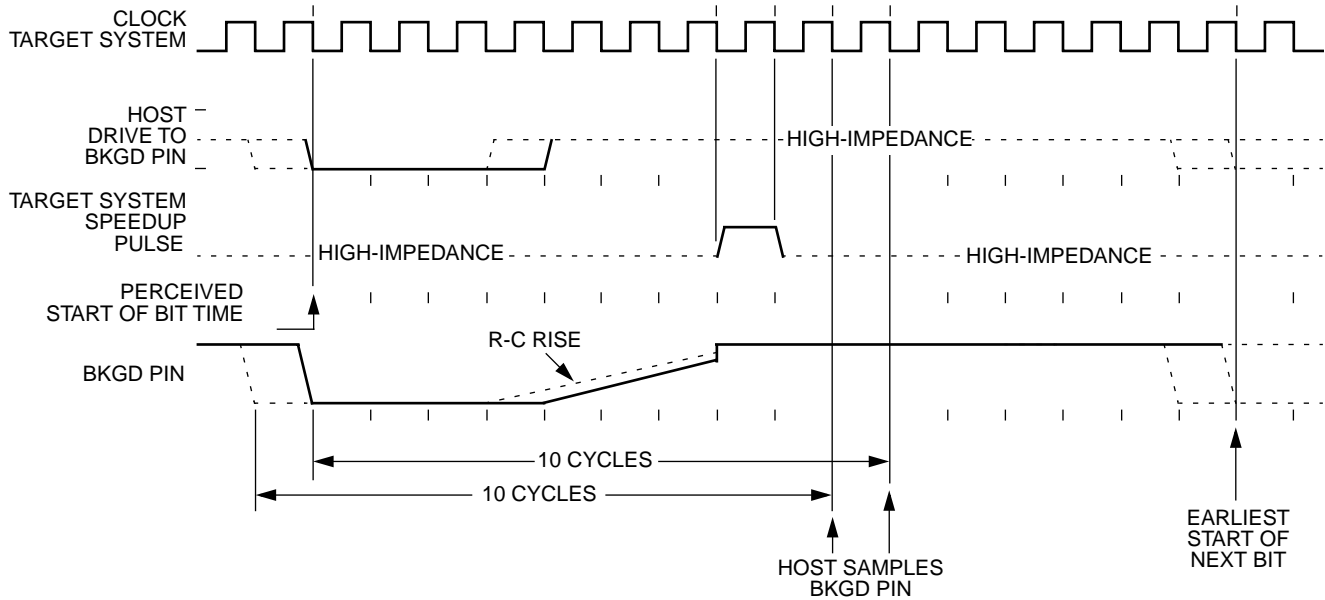

Figure 140 BDM Target-to-Host Serial Bit Timing (Logic 1)

Figure 141 shows the host receiving a logic 0 from the target. Since the host is asynchronous to the target, there is up to a one clock-cycle delay from the host-generated falling edge on BKGD to the start of the bit time as perceived by the target. The host initiates the bit time but the target finishes it. Since the target wants the host to receive a logic 0, it drives the BKGD pin low for 13 target clock cycles then briefly drives it high to speed up the rising edge. The host samples the bit level about 10 target clock cycles after starting the bit time.

Background Debug Module

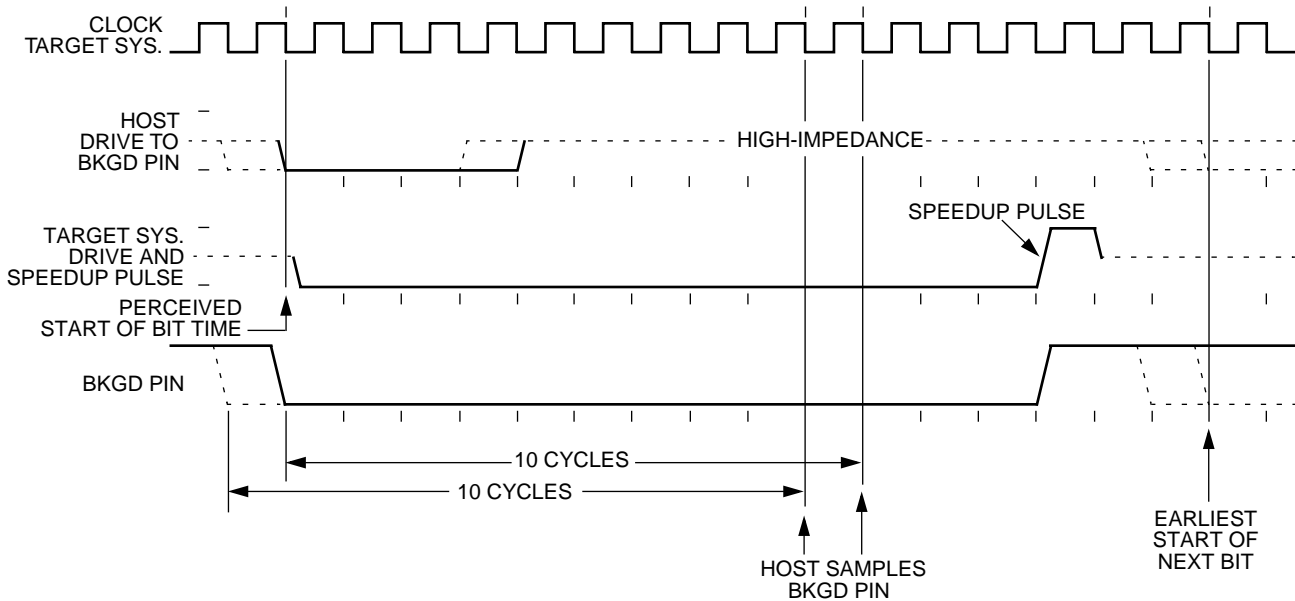

Figure 141 BDM Target-to-Host Serial Bit Timing (Logic 0)

Instruction Tracing

When a TRACE1 command is issued to the BDM in active BDM, the CPU exits the standard BDM firmware and executes a single instruction in the user code. Once this has occurred, the CPU is forced to return to the standard BDM firmware and the BDM is active and ready to receive a new command. If the TRACE1 command is issued again, the next user instruction will be executed. This facilitates stepping or tracing through the user code one instruction at a time.

If an interrupt is pending when a TRACE1 command is issued, the interrupt stacking operation occurs but no user instruction is executed. Once back in standard BDM firmware execution, the program counter points to the first instruction in the interrupt service routine.

Instruction Tagging

The instruction queue and cycle-by-cycle CPU activity are reconstructible in real time or from trace history that is captured by a logic analyzer. However, the reconstructed queue cannot be used to stop the CPU at a specific instruction, because execution already has begun by the time an operation is visible outside the system. A separate instruction tagging mechanism is provided for this purpose.

The tag follows program information as it advances through the instruction queue. When a tagged instruction reaches the head of the queue, the CPU enters active BDM rather than executing the instruction.

NOTE: *Tagging is disabled when BDM becomes active and BDM serial commands are not processed while tagging is active.*

Executing the BDM TAGGO command configures two system pins for tagging. The TAGLO signal shares a pin with the LSTRB signal, and the TAGHI signal shares a pin with the BKGD signal.

Table 123 shows the functions of the two tagging pins. The pins operate independently, that is, the state of one pin does not affect the function of the other. The presence of logic level 0 on either pin at the fall of the external clock (ECLK) performs the indicated function. High tagging is allowed in all modes. Low tagging is allowed only when low strobe is enabled (LSTRB is allowed only in wide expanded modes and emulation expanded narrow mode).

Table 123 Tag Pin Function

TAGHI	TAGLO	Tag
1	1	No tag
1	0	Low byte
0	1	High byte
0	0	Both bytes

Modes of Operation

BDM is available in all operating modes but must be enabled before firmware commands are executed.

Some system peripherals may have a control bit which allows suspending the peripheral function during background debug mode.

In special single-chip mode, background operation is enabled and active out of reset. This allows programming a system with blank memory.

BDM is also active out of special peripheral mode reset and can be turned off by clearing the BDMACT bit in the BDM status (BDMSTS) register. This allows testing of the BDM memory space as well as the user's memory space.

NOTE: *The BDM serial system should not be used in special peripheral mode since the CPU, which in other modes interfaces with the BDM to relinquish control of the bus during a free cycle or a steal operation, is not operating in this mode.*

Normal Operation BDM operates the same in all normal modes.

Special Operation

Special single-chip mode BDM is enabled and active immediately out of reset. This allows programming a system with blank memory.

Special peripheral mode BDM is enabled and active immediately out of reset. BDM can be disabled by clearing the BDMACT bit in the BDM status (BDMSTS) register. The BDM serial system should not be used in special peripheral mode.

Emulation Modes In emulation modes, the BDM operates as in all normal modes.

Low-Power Options

Run Mode The BDM does not include disable controls that would conserve power during run mode.

Wait Mode The BDM cannot be used in wait mode if the system disables the clocks to the BDM.

Stop Mode The BDM is completely shutdown in stop mode.

Interrupt Operation

The BDM does not generate interrupt requests.



Breakpoint (BKP) Module

Contents

Overview	713
Features	714
Block Diagram	715
External Pin Descriptions	716
Register Descriptions	716
Functional Description	723
Breakpoint Operating Modes	724
Breakpoint Types	725
Modes of Operation	725
Low Power Options	726
Modes of Operation	725
Interrupt Operation	726
General Purpose I/O Ports	726

Overview

Hardware breakpoints are used to debug software on the STAR12 CPU by comparing actual address and data values to predetermined data in setup registers. A successful comparison will place the CPU in background debug mode (BDM) or initiate a software interrupt (SWI).

The Breakpoint Module contains two modes of operation:

1. Dual Address Mode, where a match on either of two addresses will cause a Software Interrupt (SWI) or cause the part to enter Background Debug Mode.
2. Full Breakpoint Mode, where a match on address and data will cause a Software Interrupt (SWI) or cause the part to enter Background Debug Mode.

Breakpoint (BKP) Module

There are two types of breakpoints: tagged and forced. Forced breakpoints occur at the next instruction boundary if a match occurs and tagged breakpoints allow breaking just before a specific instruction executes. Tagged breakpoints will only occur on addresses. Tagging on data is not allowed; however, if this occurs, nothing will occur within the BKP module.

The breakpoint module allows breaking within a 256 byte address range and/or within expanded memory, allows matching of the data bus as well as address matching, allows breakpoints to match 8 bit or 16 bit data, and allows forced breakpoints to match on a read or write cycle.

Features

- Full or Dual Breakpoint Mode
 - Compare on address and data (Full)
 - Compare on either of two addresses (Dual)
- BDM or SWI Breakpoint
 - Enter BDM on breakpoint (BDM)
 - Execute SWI on breakpoint (SWI)
- Tagged or Forced Breakpoint
 - Break just before a specific instruction will begin execution (TAG)
 - Break on the first instruction boundary after a match occurs (Force)
- Single, Range, or Page address compares
 - Compare on address (Single)
 - Compare on address 256 byte (Range)
 - Compare on any 16K Page (Page)
- Compare address on read or write on forced breakpoints
- High and/or low byte data compares

Block Diagram

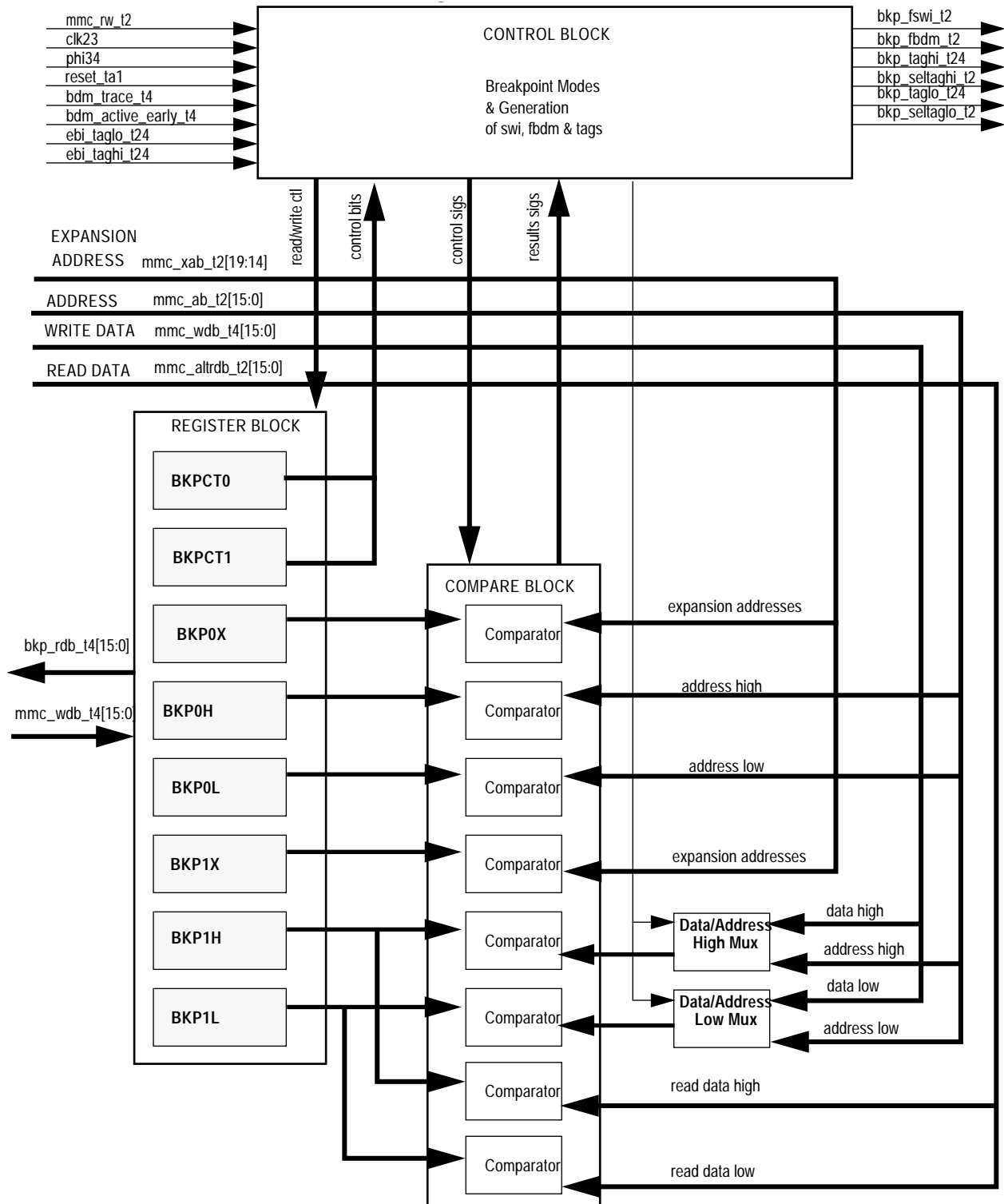

Figure 142 Breakpoint Module Block Diagram

Breakpoint (BKP) Module

External Pin Descriptions

The BKP sub-block does not access any external pins.

Register Descriptions

There are eight 8-bit registers in the BKP module.

NOTE: *All bits of all registers in this module are completely synchronous to internal clocks during a register read.*

Breakpoint Control Register 0 (BKPCT0) This register is used to set the breakpoint modes.
Read and write: anytime.

Address \$_00

	Bit 7	6	5	4	3	2	1	Bit 0
Read:	BKEN	BKFULL	BKBDM	BKTAG	0	0	0	0
Write:								
Reset:	0	0	0	0	0	0	0	0

= Reserved or unimplemented

BKEN — Breakpoint Enable

This bit enables the module.
0 = Breakpoint module off.
1 = Breakpoint module on.

BKFULL— Full Breakpoint Mode Enable

This bit controls whether the breakpoint module is in Dual Mode or Full Mode
0 = Dual Address Mode enabled.
1 = Full Breakpoint Mode enabled.

BKBDM — Breakpoint Background Debug Mode Enable

This bit determines if the breakpoint causes the part to enter Background Debug Mode (BDM) or initiate a Software Interrupt (SWI)

- 0 = Go to Software Interrupt on a compare.
- 1 = Go to BDM on a compare.

BKTAG — Breakpoint on Tag

This bit controls whether the breakpoint will cause a break on the next instruction boundary (force) or on a match that will be an executable opcode (tagged). Non-executed opcodes cannot cause a tagged breakpoint

- 0 = On match, break at the next instruction boundary (force).
- 1 = On match, break if the match is an instruction that will be executed (tagged).

Breakpoint Control Register 1 (BKPC1)

This register is used to control the breakpoint logic that resides within the Core.

Read and write: anytime.

Address	\$_01							
	Bit 7	6	5	4	3	2	1	Bit 0
Read:	BK0MBH	BK0MBL	BK1MBH	BK1MBL	BK0RWE	BK0RW	BK1RWE	BK1RW
Write:								
Reset:	0	0	0	0	0	0	0	0

BK0MBH:BK0MBL — Breakpoint Mask High Byte and Low Byte for First Address

In Dual or Full Mode, these bits may be used to mask (disable) the comparison of the high and low bytes of the first address breakpoint. (See **Table 124.**)

Table 124 Breakpoint Mask Bits for First Address

BK0MBH:BK0MBL	Address Compare	BKP0X	BKP0H	BKP0L
x:0	Full Address Compare	Yes ⁽¹⁾	Yes	Yes
0:1	256 byte Address Range	Yes ⁽¹⁾	Yes	No
1:1	16K byte Address Range	Yes ⁽¹⁾	No	No

1. If page is selected.

The x:0 case is for a Full Address Compare. When a program page is selected the full address compare will be based on bits {mmc_xab[19:14],mmc_ab_t2[13:0]} for a 20-bit compare. The registers used for the compare are {BKP0X[5:0],BKP0H[5:0],BKP0L[7:0]}. When a program page is not selected the full address compare will be based on bits mmc_ab_t2[15:0] for a 16-bit compare. The registers used for the compare are {BKP0H[7:0],BKP0L[7:0]}.

The 1:0 case is not sensible because it would ignore the high order address and compare the low order and expansion addresses. Logic forces this case to compare all address lines (effectively ignoring the BK0MBH control bit).

The 1:1 case is useful for triggering a breakpoint on any access to a particular expansion page. This only makes sense if a program page is being accessed so the breakpoint trigger will only occur if BKP0X compares.

BK1MBH:BK1MBL — Breakpoint Mask High Byte and Low Byte of Data (Second Address)

In Dual Mode, these bits may be used to mask (disable) the comparison of the high and/or low bytes of the second address breakpoint. (See **Table 125**).

Table 125 Breakpoint Mask Bits for Second Address (Dual Mode)

BK1MBH:BK1MBL	Address Compare	BKP1X	BKP1H	BKP1L
x:0	Full Address Compare	Yes ⁽¹⁾	Yes	Yes
0:1	256 byte Address Range	Yes ⁽¹⁾	Yes	No
1:1	16K byte Address Range	Yes ⁽¹⁾	No	No

1. If page is selected.

The x:0 case is for a Full Address Compare. When a program page is selected the full address compare will be based on bits {mmc_xab[19:14],mmc_ab_t2[13:0]} for a 20-bit compare. The registers used for the compare are {BKP1X[5:0],BKP1H[5:0],BKP1L[7:0]}. When a program page is not selected the full address compare will be based on bits mmc_ab_t2[15:0] for a 16-bit compare. The registers used for the compare are {BKP1H[7:0],BKP1L[7:0]}.

The 1:0 case is not sensible because it would ignore the high order address and compare the low order and expansion addresses. Logic forces this case to compare all address lines (effectively ignoring the BK1MBH control bit).

The 1:1 case is useful for triggering a breakpoint on any access to a particular expansion page. This only makes sense if a program page is being accessed so the breakpoint trigger will only occur if BKP1X compares.

Breakpoint (BKP) Module

In Full Mode, these bits may be used to mask (disable) the comparison of the high and/or low bytes of the data breakpoint. (See **Table 126**.)

Table 126 Breakpoint Mask Bits for Data Breakpoints (Full Mode)

BK1MBH:BK1MBL	Data Compare	BKP1X	BKP1H	BKP1L
0:0	High and Low Byte Compare	No ⁽¹⁾	Yes	Yes
0:1	High Byte	No ⁽¹⁾	Yes	No
1:0	Low Byte	No ⁽¹⁾	No	Yes
1:1	No Compare	No ⁽¹⁾	No	No

1. Expansion addresses for breakpoint 1 are not available in this mode.

BK0RWE — R/\overline{W} Compare Enable

Enables the comparison of the R/\overline{W} signal for first address breakpoint. This bit is not useful in tagged breakpoints.

0 = R/\overline{W} is not used in the comparisons.

1 = R/\overline{W} is used in comparisons.

BK0RW — R/\overline{W} Compare Value

When BK0RWE=1, this bit determines the type of bus cycle to match on first address breakpoint. When BK0RWE=0, this bit has no effect.

0 = Write cycle will be matched.

1 = Read cycle will be matched

BK1RWE — R/\overline{W} Compare Enable

In Dual Mode, this bit enables the comparison of the R/\overline{W} signal to further specify what causes a match for the second address breakpoint. This bit is not useful on tagged breakpoints or in Full Mode and is therefore a don't care.

0 = R/\overline{W} is not used in comparisons.

1 = R/\overline{W} is used in comparisons.

BK1RW — R/W Compare Value

When BK1RWE=1, this bit determines the type of bus cycle to match on the second address breakpoint. When BK1RWE=0, this bit has no effect.

0 = Write cycle will be matched.

1 = Read cycle will be matched.

**First Address
Memory
Expansion
Breakpoint
Register (BKPOX)**

This register contains the data to be matched against expansion address lines for the first address breakpoint when a page is selected.

Read and write: anytime.

Address	\$__02							
	Bit 7	6	5	4	3	2	1	Bit 0
Read:	0	0	BK0V5	BK0V4	BK0V3	BK0V2	BK0V1	BK0V0
Write:								
Reset:	0	0	0	0	0	0	0	0

= Reserved or unimplemented

BK0V[5:0] — First Address Breakpoint Expansion Address Value

**First Address High
Byte Breakpoint
Register (BKP0H)**

This register is used to set the breakpoint when compared against the high byte of the address.

Read and write: anytime

Address	\$__03							
	Bit 7	6	5	4	3	2	1	Bit 0
Read:	Bit 15	14	13	12	11	10	9	Bit 8
Write:								
Reset:	0	0	0	0	0	0	0	0

Breakpoint (BKP) Module

First Address Low Byte Breakpoint Register (BKP0L) This register is used to set the breakpoint when compared against the low byte of the address.
Read and write: anytime

Address \$_04

	Bit 7	6	5	4	3	2	1	Bit 0
Read:	Bit 7	6	5	4	3	2	1	Bit 0
Write:	Bit 7	6	5	4	3	2	1	Bit 0
Reset:	0	0	0	0	0	0	0	0

Second Address Memory Expansion Breakpoint Register (BKP1X) In Dual Mode, this register contains the data to be matched against expansion address lines for the second address breakpoint when a page is selected. In Full Mode, this register is not used.
Read and write: anytime

Address \$_05

	Bit 7	6	5	4	3	2	1	Bit 0
Read:	0	0	BK1V5	BK1V4	BK1V3	BK1V2	BK1V1	BK1V0
Write:			BK1V5	BK1V4	BK1V3	BK1V2	BK1V1	BK1V0
Reset:	0	0	0	0	0	0	0	0

= Reserved or unimplemented

BK1V[5:0] — Second Address Breakpoint Expansion Address Value

Data (Second Address) High Byte Breakpoint Register (BKP1H) In Dual Mode, this register is used to compare against the high order address lines. In Full Mode, this register is used to compare against the high order data lines.
Read and write: anytime

Address \$_06

	Bit 7	6	5	4	3	2	1	Bit 0
Read:	Bit 15	14	13	12	11	10	9	Bit 8
Write:	Bit 15	14	13	12	11	10	9	Bit 8
Reset:	0	0	0	0	0	0	0	0

Data (Second Address) Low Byte Breakpoint Register (BKP1L)

In Dual Mode, this register is used to compare against the low order address lines. In Full Mode, this register is used to compare against the low order data lines.

Read and write: anytime

Address	\$_07							
	Bit 7	6	5	4	3	2	1	Bit 0
Read:	Bit 7	6	5	4	3	2	1	Bit 0
Write:								
Reset:	0	0	0	0	0	0	0	0

Functional Description

There are three main sub-blocks in the breakpoint module.

Register Block This block contains the eight registers which make up the BKP register space.

Compare Block This block contains all logic necessary to perform the required address and data signal comparisons.

Control Block This block contains the generation and drive logic for the tag high, tag low, force SWI and force BDM signals for the CPU. It also generates the register read and write signals and comparator block enables.

NOTE: *There is a two cycle latency for address compares for forces, two cycle latency for write data compares, and a three cycle latency for read data compares.*

Breakpoint Operating Modes

Dual Address Mode

When Dual Address Mode is enabled, two address breakpoints can be set. Each breakpoint can cause a software interrupt (SWI) or cause the part to enter BDM. The BDM requests have a higher priority than the SWI requests. No data breakpoints are allowed.

The BKTAG bit in the BKPCT0 register selects whether the breakpoint mode is force or tag. The BKxMBH:L bits in the BKPCT1 register select whether or not the breakpoint is matched exactly or is a range breakpoint. They also select whether the address is matched on the high byte, low byte, both bytes, and/or memory expansion. The BKxRW and BKxRWE bits in the BKPCT1 register select whether the type of bus cycle to match is a read, write, or both when performing forced breakpoints.

Full Breakpoint Mode

When in Full Breakpoint Mode, the part enters background debug mode or initiates a software interrupt. The BDM requests have a higher priority than the SWI requests. This mode requires a match on address and data for a breakpoint to occur. R/W matches are also allowed.

The BKTAG bit in the BKPCT0 register selects whether the breakpoint mode is forced or tagged. If the BKTAG bit is set in BKPCT0, then only address is matched, data is ignored. The BK0MBH:L bits in the BKPCT1 register select whether or not the breakpoint is matched exactly, is a range breakpoint, or is in page space. The BK1MBH:L bits in the BKPCT1 register select whether the data is matched on the high byte, low byte, or both bytes. The BK0RW and BK0RWE bits in the BKPCT1 register select whether the type of bus cycle to match is a read or a write when performing forced breakpoints. BK1RW and BK1RWE bits in the BKPCT1 register are not used in Full Mode.

Breakpoint Types

The priority of the breakpoint types is as follows. The Breakpoint module gives priority to BDM requests over SWI requests. The external bus interface tags that pass through the BKP module can only assert BDM requests.

Table 127 Priority of Forces and Tags

Forces	Tags
Force BDM from BDM Module	External Bus Interface Tags
Force BDM from BKP Module	Breakpoint Module Tags

SWI

During a breakpoint, a signal generated by the breakpoint module is asserted, causing the CPU to execute a SWI instead of the BGND instruction.

BDM

Breakpoints are not allowed if the BDM mode is already active. Active mode means the CPU is executing out of the BDM ROM. While in BDM trace mode, tagging into BDM is not allowed.

NOTE: *BDM should not be entered from a breakpoint unless the ENABLE bit is set in the BDM. Even if the ENABLE bit in the BDM is negated, the CPU actually executes the BDM ROM code. It checks the ENABLE and returns if enable is not set. If the BDM is not serviced by the monitor, then the breakpoint would be re-asserted when the BDM returns to normal CPU flow.*

There is no hardware to enforce restriction of breakpoint operation if the BDM is not enabled.

Modes of Operation

The Breakpoint Module performs the same in all modes of operation.

Breakpoint (BKP) Module

Low Power Options

Low power options are available in the BKP sub-block.

Run Mode In run mode, if BKEN=0, all clocks to the breakpoint system are disabled.

Wait Mode Wait mode power savings can be achieved by having the clock generator shut down the core clock if the BDM is not used.

Stop Mode The BKP sub-block will be completely shutdown during a STOP instruction.

Reset Initialization

The reset state of each individual bit is listed within the Register Description section, which details the registers and their bit-fields. All registers are reset by the system reset.

Interrupt Operation

The BKP sub-block causes the CPU to generate SWI interrupts when BKBDM bit is equal to zero.

General Purpose I/O Ports

The BKP sub-block does not include any general purpose I/O ports.

Revision History

This section lists the revision history of the document since Rev 1.0 (the first general release). Data for previous revisions is unavailable.

Changes from Rev 1.0 to Rev 1.1

Section	Page (in Rev 1.1)	Description of change
General Description	various	Notes about 80-pin version of device added
Pinout and Signal Description	various	Notes about 80-pin version of device added
Pinout and Signal Description	54	Table 7: Pin 46 corrected from XTAL to EXTAL
Pinout and Signal Description	54	Table 7: Pin 47 corrected from EXTAL to XTAL
Pinout and Signal Description	55	Table 7: Pin 68 corrected from PAD10/AN08 to PAD08/AN08



Revision History

A — See “accumulators (A and B or D).”

accumulators (A and B or D) — Two 8-bit (A and B) or one 16-bit (D) general-purpose registers in the CPU. The CPU uses the accumulators to hold operands and results of arithmetic and logic operations.

acquisition mode — A mode of PLL operation with large loop bandwidth. Also see ‘tracking mode’.

address bus — The set of wires that the CPU or DMA uses to read and write memory locations.

addressing mode — The way that the CPU determines the operand address for an instruction. The M68HC12 CPU has 15 addressing modes.

ALU — See “arithmetic logic unit (ALU).”

analogue-to-digital converter (ATD) — The ATD module is an 8-channel, multiplexed-input successive-approximation analog-to-digital converter.

arithmetic logic unit (ALU) — The portion of the CPU that contains the logic circuitry to perform arithmetic, logic, and manipulation operations on operands.

asynchronous — Refers to logic circuits and operations that are not synchronized by a common reference signal.

ATD — See “analogue-to-digital converter”.

B — See “accumulators (A and B or D).”

baud rate — The total number of bits transmitted per unit of time.

BCD — See “binary-coded decimal (BCD).”

binary — Relating to the base 2 number system.

binary number system — The base 2 number system, having two digits, 0 and 1. Binary arithmetic is convenient in digital circuit design because digital circuits have two permissible voltage levels, low and high. The binary digits 0 and 1 can be interpreted to correspond to the two digital voltage levels.

binary-coded decimal (BCD) — A notation that uses 4-bit binary numbers to represent the 10 decimal digits and that retains the same positional structure of a decimal number. For example,

234 (decimal) = 0010 0011 0100 (BCD)

bit — A binary digit. A bit has a value of either logic 0 or logic 1.

branch instruction — An instruction that causes the CPU to continue processing at a memory location other than the next sequential address.

break module — The break module allows software to halt program execution at a programmable point in order to enter a background routine.

breakpoint — A number written into the break address registers of the break module. When a number appears on the internal address bus that is the same as the number in the break address registers, the CPU executes the software interrupt instruction (SWI).

break interrupt — A software interrupt caused by the appearance on the internal address bus of the same value that is written in the break address registers.

bus — A set of wires that transfers logic signals.

bus clock — See "CPU clock".

byte — A set of eight bits.

CAN — See "Motorola scalable CAN."

CCR — See "condition code register."

central processor unit (CPU) — The primary functioning unit of any computer system. The CPU controls the execution of instructions.

CGM — See "clock generator module (CGM)."

clear — To change a bit from logic 1 to logic 0; the opposite of set.

clock — A square wave signal used to synchronize events in a computer.

clock generator module (CGM) — The CGM module generates a base clock signal from which the system clocks are derived. The CGM may include a crystal oscillator circuit and/or phase-locked loop (PLL) circuit.

comparator — A device that compares the magnitude of two inputs. A digital comparator defines the equality or relative differences between two binary numbers.

computer operating properly module (COP) — A counter module that resets the MCU if allowed to overflow.

condition code register (CCR) — An 8-bit register in the CPU that contains the interrupt mask bit and five bits that indicate the results of the instruction just executed.

control bit — One bit of a register manipulated by software to control the operation of the module.

control unit — One of two major units of the CPU. The control unit contains logic functions that synchronize the machine and direct various operations. The control unit decodes instructions and generates the internal control signals that perform the requested operations. The outputs of the control unit drive the execution unit, which contains the arithmetic logic unit (ALU), CPU registers, and bus interface.

COP — See "computer operating properly module (COP)."

CPU — See "central processor unit (CPU)."

CPU12 — The CPU of the MC68HC12 Family.

CPU clock — Bus clock select bits BCSP and BCSS in the clock select register (CLKSEL) determine which clock drives SYSCLK for the main system, including the CPU and buses. When EXTALi drives the SYSCLK, the CPU or bus clock frequency (f_0) is equal to the EXTALi frequency divided by 2.

CPU cycles — A CPU cycle is one period of the internal bus clock, normally derived by dividing a crystal oscillator source by two or more so the high and low times will be equal. The length of time required to execute an instruction is measured in CPU clock cycles.

CPU registers — Memory locations that are wired directly into the CPU logic instead of being part of the addressable memory map. The CPU always has direct access to the information in these registers. The CPU registers in an M68HC12 are:

- A (8-bit accumulator)
- B (8-bit accumulator)
 - D (16-bit accumulator formed by concatenation of accumulators A and B)
- IX (16-bit index register)
- IY (16-bit index register)
- SP (16-bit stack pointer)
- PC (16-bit program counter)
- CCR (8-bit condition code register)

cycle time — The period of the operating frequency: $t_{CYC} = 1/f_{OP}$.

D — See “accumulators (A and B or D).”

decimal number system — Base 10 numbering system that uses the digits zero through nine.

duty cycle — A ratio of the amount of time the signal is on versus the time it is off. Duty cycle is usually represented by a percentage.

ECT — See “enhanced capture timer.”

EEPROM — Electrically erasable, programmable, read-only memory. A nonvolatile type of memory that can be electrically erased and reprogrammed.

EPROM — Erasable, programmable, read-only memory. A nonvolatile type of memory that can be erased by exposure to an ultraviolet light source and then reprogrammed.

enhanced capture timer (ECT) — The HC12 Enhanced Capture Timer module has the features of the HC12 Standard Timer module enhanced by additional features in order to enlarge the field of applications.

exception — An event such as an interrupt or a reset that stops the sequential execution of the instructions in the main program.

fetch — To copy data from a memory location into the accumulator.

firmware — Instructions and data programmed into nonvolatile memory.

flash EEPROM — Electrically erasable, programmable, read-only memory. A nonvolatile type of memory that can be electrically erased and reprogrammed. Does not support byte or word erase.

free-running counter — A device that counts from zero to a predetermined number, then rolls over to zero and begins counting again.

full-duplex transmission — Communication on a channel in which data can be sent and received simultaneously.

hexadecimal — Base 16 numbering system that uses the digits 0 through 9 and the letters A through F.

high byte — The most significant eight bits of a word.

illegal address — An address not within the memory map

illegal opcode — A nonexistent opcode.

index registers (IX and IY) — Two 16-bit registers in the CPU. In the indexed addressing modes, the CPU uses the contents of IX or IY to determine the effective address of the operand. IX and IY can also serve as a temporary data storage locations.

input/output (I/O) — Input/output interfaces between a computer system and the external world. A CPU reads an input to sense the level of an external signal and writes to an output to change the level on an external signal.

instructions — Operations that a CPU can perform. Instructions are expressed by programmers as assembly language mnemonics. A CPU interprets an opcode and its associated operand(s) and instruction.

interrupt — A temporary break in the sequential execution of a program to respond to signals from peripheral devices by executing a subroutine.

interrupt request — A signal from a peripheral to the CPU intended to cause the CPU to execute a subroutine.

I/O — See “input/output (I/O).”

jitter — Short-term signal instability.

latch — A circuit that retains the voltage level (logic 1 or logic 0) written to it for as long as power is applied to the circuit.

latency — The time lag between instruction completion and data movement.

least significant bit (LSB) — The rightmost digit of a binary number.

logic 1 — A voltage level approximately equal to the input power voltage (V_{DD}).

logic 0 — A voltage level approximately equal to the ground voltage (V_{SS}).

low byte — The least significant eight bits of a word.

M68HC12 — A Motorola family of 16-bit MCUs.

mark/space — The logic 1/logic 0 convention used in formatting data in serial communication.

mask — 1. A logic circuit that forces a bit or group of bits to a desired state. 2. A photomask used in integrated circuit fabrication to transfer an image onto silicon.

MCU — Microcontroller unit. See “microcontroller.”

memory location — Each M68HC12 memory location holds one byte of data and has a unique address. To store information in a memory location, the CPU places the address of the location on the address bus, the data information on the data bus, and asserts the write signal. To read information from a memory location, the CPU places the address of the location on the address bus and asserts the read signal. In response to the read signal, the selected memory location places its data onto the data bus.

memory map — A pictorial representation of all memory locations in a computer system.

MI-Bus — See "Motorola interconnect bus".

microcontroller — Microcontroller unit (MCU). A complete computer system, including a CPU, memory, a clock oscillator, and input/output (I/O) on a single integrated circuit.

modulo counter — A counter that can be programmed to count to any number from zero to its maximum possible modulus.

most significant bit (MSB) — The leftmost digit of a binary number.

Motorola interconnect bus (MI-Bus) — The Motorola Interconnect Bus (MI Bus) is a serial communications protocol which supports distributed real-time control efficiently and with a high degree of noise immunity.

Motorola scalable CAN (msCAN) — The Motorola scalable controller area network is a serial communications protocol that efficiently supports distributed real-time control with a very high level of data integrity.

msCAN — See "Motorola scalable CAN".

MSI — See "multiple serial interface".

multiple serial interface — A module consisting of multiple independent serial I/O sub-systems, e.g. two SCI and one SPI.

multiplexer — A device that can select one of a number of inputs and pass the logic level of that input on to the output.

nibble — A set of four bits (half of a byte).

object code — The output from an assembler or compiler that is itself executable machine code, or is suitable for processing to produce executable machine code.

opcode — A binary code that instructs the CPU to perform an operation.

open-drain — An output that has no pullup transistor. An external pullup device can be connected to the power supply to provide the logic 1 output voltage.

operand — Data on which an operation is performed. Usually a statement consists of an operator and an operand. For example, the operator may be an add instruction, and the operand may be the quantity to be added.

oscillator — A circuit that produces a constant frequency square wave that is used by the computer as a timing and sequencing reference.

OTPROM — One-time programmable read-only memory. A nonvolatile type of memory that cannot be reprogrammed.

- overflow** — A quantity that is too large to be contained in one byte or one word.
- page zero** — The first 256 bytes of memory (addresses \$0000–\$00FF).
- parity** — An error-checking scheme that counts the number of logic 1s in each byte transmitted. In a system that uses odd parity, every byte is expected to have an odd number of logic 1s. In an even parity system, every byte should have an even number of logic 1s. In the transmitter, a parity generator appends an extra bit to each byte to make the number of logic 1s odd for odd parity or even for even parity. A parity checker in the receiver counts the number of logic 1s in each byte. The parity checker generates an error signal if it finds a byte with an incorrect number of logic 1s.
- PC** — See “program counter (PC).”
- peripheral** — A circuit not under direct CPU control.
- phase-locked loop (PLL)** — A clock generator circuit in which a voltage controlled oscillator produces an oscillation which is synchronized to a reference signal.
- PLL** — See "phase-locked loop (PLL)."
- pointer** — Pointer register. An index register is sometimes called a pointer register because its contents are used in the calculation of the address of an operand, and therefore points to the operand.

- polarity** — The two opposite logic levels, logic 1 and logic 0, which correspond to two different voltage levels, V_{DD} and V_{SS} .
- polling** — Periodically reading a status bit to monitor the condition of a peripheral device.
- port** — A set of wires for communicating with off-chip devices.
- prescaler** — A circuit that generates an output signal related to the input signal by a fractional scale factor such as 1/2, 1/8, 1/10 etc.
- program** — A set of computer instructions that cause a computer to perform a desired operation or operations.
- program counter (PC)** — A 16-bit register in the CPU. The PC register holds the address of the next instruction or operand that the CPU will use.
- pull** — An instruction that copies into the accumulator the contents of a stack RAM location. The stack RAM address is in the stack pointer.
- pullup** — A transistor in the output of a logic gate that connects the output to the logic 1 voltage of the power supply.
- pulse-width** — The amount of time a signal is on as opposed to being in its off state.
- pulse-width modulation (PWM)** — Controlled variation (modulation) of the pulse width of a signal with a constant frequency.
- push** — An instruction that copies the contents of the accumulator to the stack RAM. The stack RAM address is in the stack pointer.
- PWM period** — The time required for one complete cycle of a PWM waveform.

RAM — Random access memory. All RAM locations can be read or written by the CPU. The contents of a RAM memory location remain valid until the CPU writes a different value or until power is turned off.

RC circuit — A circuit consisting of capacitors and resistors having a defined time constant.

read — To copy the contents of a memory location to the accumulator.

register — A circuit that stores a group of bits.

reserved memory location — A memory location that is used only in special factory test modes. Writing to a reserved location has no effect. Reading a reserved location returns an unpredictable value.

reset — To force a device to a known condition.

ROM — Read-only memory. A type of memory that can be read but cannot be changed (written). The contents of ROM must be specified before manufacturing the MCU.

SCI — See "serial communication interface module (SCI)."

serial — Pertaining to sequential transmission over a single line.

serial communications interface module (SCI) — A module that supports asynchronous communication.

serial peripheral interface module (SPI) — A module that supports synchronous communication.

set — To change a bit from logic 0 to logic 1; opposite of clear.

shift register — A chain of circuits that can retain the logic levels (logic 1 or logic 0) written to them and that can shift the logic levels to the right or left through adjacent circuits in the chain.

signed — A binary number notation that accommodates both positive and negative numbers. The most significant bit is used to indicate whether the number is positive or negative, normally logic 0 for positive and logic 1 for negative. The other seven bits indicate the magnitude of the number.

software — Instructions and data that control the operation of a microcontroller.

software interrupt (SWI) — An instruction that causes an interrupt and its associated vector fetch.

SPI — See "serial peripheral interface module (SPI)."

stack — A portion of RAM reserved for storage of CPU register contents and subroutine return addresses.

stack pointer (SP) — A 16-bit register in the CPU containing the address of the next available storage location on the stack.

start bit — A bit that signals the beginning of an asynchronous serial transmission.

status bit — A register bit that indicates the condition of a device.

stop bit — A bit that signals the end of an asynchronous serial transmission.

subroutine — A sequence of instructions to be used more than once in the course of a program. The last instruction in a subroutine is a return from subroutine (RTS) instruction. At each place in the main program where the subroutine instructions are needed, a jump or branch to subroutine (JSR or BSR) instruction is used to call the subroutine. The CPU leaves the flow of the main program to execute the instructions in the subroutine. When the RTS instruction is executed, the CPU returns to the main program where it left off.

synchronous — Refers to logic circuits and operations that are synchronized by a common reference signal.

timer — A module used to relate events in a system to a point in time.

toggle — To change the state of an output from a logic 0 to a logic 1 or from a logic 1 to a logic 0.

tracking mode — A mode of PLL operation with narrow loop bandwidth. Also see 'acquisition mode.'

two's complement — A means of performing binary subtraction using addition techniques. The most significant bit of a two's complement number indicates the sign of the number (1 indicates negative). The two's complement negative of a number is obtained by inverting each bit in the number and then adding 1 to the result.

unbuffered — Utilizes only one register for data; new data overwrites current data.

unimplemented memory location — A memory location that is not used. Writing to an unimplemented location has no effect. Reading an unimplemented location returns an unpredictable value.

variable — A value that changes during the course of program execution.

VCO — See "voltage-controlled oscillator."

vector — A memory location that contains the address of the beginning of a subroutine written to service an interrupt or reset.

voltage-controlled oscillator (VCO) — A circuit that produces an oscillating output signal of a frequency that is controlled by a dc voltage applied to a control input.

waveform — A graphical representation in which the amplitude of a wave is plotted against time.

wired-OR — Connection of circuit outputs so that if any output is high, the connection point is high.

word — A set of two bytes (16 bits).

write — The transfer of a byte of data from the CPU to a memory location.



Literature Updates

This document contains the latest data available at publication time. For updates, contact one of the centers listed below:

Literature Distribution Centers

Order literature by mail or phone.

USA/Europe

Motorola Literature Distribution
P.O. Box 5405
Denver, Colorado, 80217
Phone 1-303-675-2140

Japan

Motorola Japan Ltd.
Tatsumi-SPD-JLDC
Toshikatsu Otsuki
6F Seibu-Butsuryu Center
3-14-2 Tatsumi Koto-Ku
Tokyo 135, Japan
Phone 03-3521-8315

Hong Kong

Motorola Semiconductors H.K. Ltd.
8B Tai Ping Industrial Park
51 Ting Kok Road
Tai Po, N.T., Hong Kong
Phone 852-26629298



Customer Focus Center

1-800-521-6274

Microcontroller Division's Web Site

Directly access the Microcontroller Division's web site with the following URL:

<http://www.motorola.com/semiconductors>



Freescale Semiconductor, Inc.

Freescale Semiconductor, Inc.

**For More Information On This Product,
Go to: www.freescale.com**



X-ON Electronics

Largest Supplier of Electrical and Electronic Components

Click to view similar products for [16-bit Microcontrollers - MCU category](#):

Click to view products by [NXP manufacturer](#):

Other Similar products are found below :

[M30302FCPP#U3](#) [MB90F036APMC-GSE1](#) [MB90F428GCPFR-GSE1](#) [MB96F683RBPMC-GSAE1](#) [R5F10MMGDFB#30](#)
[R5F111PGGFB#30](#) [R5F117BCGNA#20](#) [DF3026XBL25V](#) [DF36014GFTV](#) [DF36014GFXV](#) [DF36024GFTV](#) [DF36034GFPV](#)
[R5F11B7EANA#U0](#) [R5F21172DSP#U0](#) [MB90092PF-G-BNDE1](#) [MB90F335APMC1-G-SPE1](#) [MB90F345CAPFR-GSE1](#) [MB90F568PMCR-GE1](#) [MB90F882ASPMC-GE1](#) [MB96F395RSAPMC-GSE2](#) [DF36024GFXV](#) [UPD78F1018F1-BA4-A](#) [MB96F018RBPMC-GSE1](#)
[MB90F867ASPFR-GE1](#) [DF2239FA20IV](#) [R5F117BCGFP#30](#) [LC88F58B0AU-SQFPH](#) [MB90F548GPF-GE1](#) [MB90214PF-GT-310-BND-AE1](#)
[MB90F342CESPQC-GSE2](#) [MB90F428GAPF-GSE1](#) [ML620Q504H-NNNTBWBX](#) [S912ZVH128F2VLL](#) [UPD78F1500AGK-GAK-AX](#)
[HD64F3337SF16V](#) [MB90F428GCPF-GSE1](#) [MB90F342ESPMC-G-JNE1](#) [MB90022PF-GS-358E1](#) [MB96F395RWAPMC-GSE2](#)
[MB96395RSAPMC-GS-110E2](#) [MB90F883CSPMC-GE1](#) [S912ZVHY64F1CLL](#) [S912ZVHY64F1VLQ](#) [ST10F280](#) [MB96F338RSAPMCR-GK5E2](#) [CY90096PF-G-002-BND-ERE1](#) [ML62Q1569-NNNGAZ0AX](#) [ML62Q1739-NNNGAZ0AX](#) [ML62Q1749-NNNGAZ0AX](#)
[ML62Q1579-NNNGAZ0AX](#)