

MCF51AG128 ColdFire Microcontroller

Covers: MCF51AG128 and MCF51AG96

The MCF51AG128 is a member of the ColdFire® family of 32-bit variable-length reduced instruction set (RISC) microcontroller. This document provides an overview of the MCF51AG128 series MCUs, focusing on its highly integrated and diverse feature set.

The MCF51AG128 derivative are low-cost, low-power, and high-performance 32-bit ColdFire V1 microcontroller units (MCUs) designed for industrial and appliance applications. It is an ideal upgrade for designs based on the MC9S08AC128 series of 8-bit microcontrollers.

The MCF51AG128 features the following functional units:

- 32-bit Version 1 ColdFire® central processor unit (CPU)
 - Up to 50.33 MHz ColdFire CPU from 2.7 V to 5.5 V
 - Provide 0.94 Dhrystone 2.1 DMIPS per MHz performance when running from internal RAM (0.76 DMIPS per MHz when running from flash)
 - Implements Coldfire Instruction Set Revision C (ISA_C)
- On-chip memory
 - Up to 128 KB flash memory read/program/erase over full operating voltage and temperature
 - Up to 16 KB random access memory (RAM)
 - Security circuitry to prevent unauthorized access to RAM and flash contents
- Power-Saving Modes
 - Three ultra-low power stop modes and reduced power wait mode
 - Peripheral clock enable register can disable clocks to unused modules, thereby reducing currents
- System Protection
 - Advanced independent clocked watchdog (WDOG) with features like, robust refresh mechanism, windowed mode, high granulation timeout, fast test of timeout, and always forces a reset
 - Additional external watchdog monitor (EWM) to help reset external circuits

MCF51AG128

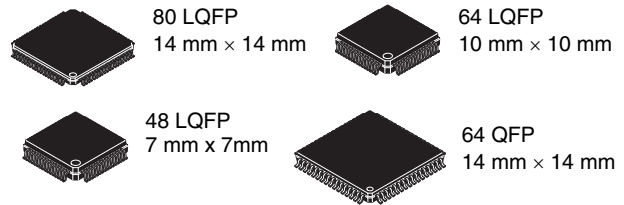

- Low-voltage detection with reset or interrupt
- Separate low voltage warning with selectable trip points
- Illegal opcode and illegal address detection with reset
- Flash block protection for each array to prevent accidental write/erasure
- Hardware CRC module to support fast cyclic redundancy checks
- Debug Support
 - Single-wire back ground debug interface
 - Real-time debug support, with six hardware breakpoints (4 PC, 1 address pair and 1 data) that can be configured into a 1- or 2-level trigger
 - On-chip trace buffer provides programmable start/stop recording conditions
 - Support for real-time program (and optional partial data) trace using the debug visibility bus
- DMA Controller
 - Four independently programmable DMA channels provide the means to directly transfer data between system memory and I/O peripherals
 - DMA enabled peripherals include IIC, SCI, SPI, FTM, HSCMP, ADC, RTC, and eGPIO, and the DMA request from these peripherals can be configured as DMA source or as an iEvent input
- CFI_INTC
 - Support of 44 peripheral I/O interrupt requests and seven software (one per level) interrupt requests
 - Fixed association between interrupt request source, level and priority, up to two requests can be remapped to the highest maskable level and priority
 - Unique vector number for each interrupt source
 - Support for service routine interrupt acknowledge (software IACK) read cycles for improved system performance
 - Ability to mask any individual or all interrupt sources

Freescale reserves the right to change the detail specifications as may be required to permit improvements in the design of its products.

- System Clock Sources
 - Oscillator (XOSC) — Loop-control pierce oscillator; crystal or ceramic resonator range of 31.25 kHz to 38.4 kHz or 1 MHz to 16 MHz
 - Internal Clock Source (ICS) — Frequency-locked-loop (FLL) controlled by internal or external reference; trimmable internal reference allows 0.2% resolution and 2% deviation (1% across 0 to 70 °C)
- Peripherals
 - ADC — 24 analog inputs with 12 bits resolution; output formatted in 12-, 10- or 8-bit right-justified format; single or continuous conversion (automatic return to idle after single conversion); interrupt or DMA request when conversion complete; operation in low-power modes for lower noise operation; asynchronous clock source for lower noise operation; selectable asynchronous hardware conversion triggers from RTC, PDB, or iEvent; dual samples based on hardware triggers during ping-pong mode; on-chip temperature sensor
 - PDB — 16-bit of resolution with prescaler; seven possible trigger events input; positive transition of trigger event signal initiates the counter; support continuous trigger or single shot, bypass mode; supports two triggered delay outputs or ORed together; pulsed output could be used for HSCMP windowing signal
 - iEvent — User programmable combinational boolean output using the four selected iEvent input channels for use as interrupt requests, DMA transfer requests, or hardware triggers
 - FTM — Two 6-channel flexible timer/PWM modules with DMA request option; deadtime insertion is available for each complementary channel pair; channels operate as pairs with equal outputs, pairs with complimentary outputs or independent channels (with independent outputs); 16-bit free-running counter; the load of the FTM registers which have write buffer can be synchronized; write protection for critical registers; backwards compatible with TPM
 - TPM — 16-bit free-running or modulo up/down count operation; two channels, each channel may be input capture, output compare, or edge-aligned PWM; one interrupt per channel plus terminal count interrupt
 - CRC — High speed hardware CRC generator circuit using 16-bit shift register; CRC16-CCITT compliancy with $x^{16} + x^{12} + x^5 + 1$ polynomial; error detection for all single, double, odd, and most multi-bit errors; programmable initial seed value
 - HSCMP — Two analog comparators with selectable interrupt on rising edge, falling edge, or either edges of comparator output; the positive and negative inputs of the comparator are both driven from 4-to-1 muxes; programmable voltage reference from two internal DACs; support DMA transfer
 - IIC — Compatible with IIC bus standard and SMBus version 2 features; up to 100 kbps with maximum bus loading; multi-master operation; software programmable for one of 64 different serial clock frequencies; programmable slave address and glitch input filter; interrupt driven byte-by-byte data transfer; arbitration lost interrupt with automatic mode switching from master to slave; calling address identification interrupt; bus busy detection; broadcast and 10-bit address extension; address matching causes wake-up when MCU is in Stop3 mode; DMA support
 - SCI — Two serial communications interface modules with optional 13-bit break; full-duplex, standard non-return-to-zero (NRZ) format; double-buffered transmitter and receiver with separate enables; 13-bit baud rate selection with /32 fractional divide; interrupt-driven or polled operation; hardware parity generation and checking; programmable 8-bit or 9-bit character length; receiver wakeup by idle-line or address-mark; address match feature in receiver to reduce address-mark wakeup ISR overhead; 1/16 bit-time noise detection; DMA transmission for both transmit and receive
 - SPI — Two serial peripheral interfaces with full-duplex or single-wire bidirectional option; double-buffered transmitter and receiver; master or slave mode operation; selectable MSB-first or LSB-first shifting; 8-bit or 16-bit data modes; programmable transmit bit rate; receive data buffer hardware match feature; DMA transmission for transmit and receive
- Input/Output
 - Up to 69 GPIOs and one Input-only pin
 - Interrupt or DMA request with selectable polarity on all input pins
 - Programmable glitch filter, hysteresis and configurable pull up/down device on all input pins
 - Configurable slew rate and drive strength on all output pins
 - Independent pin value register to read logic level on digital pin
 - Up to 16 rapid general purpose I/O (RGPIO) pins connected to the processor's local 32-bit platform bus with set, clear, and faster toggle functionality

Table of Contents

1	MCF51AG128 Family Configurations	4
1.1	Device Comparison	4
1.2	Block Diagram	5
1.3	Features	7
1.4	Pin Assignments	9
2	Preliminary Electrical Characteristics	14
2.1	Parameter Classification	14
2.2	Absolute Maximum Ratings	14
2.3	Thermal Characteristics	15
2.4	Electrostatic Discharge (ESD) Protection Characteristics	16
2.5	DC Characteristics	17
2.6	Supply Current Characteristics	21
2.7	High Speed Comparator (HSCMP) Electricals	23
2.8	Digital to Analog (DAC) Characteristics	23
2.9	ADC Characteristics	23
2.10	External Oscillator (XOSC) Characteristics	27
2.11	ICS Specifications	28
2.12	AC Characteristics	30
2.12.1	Control Timing	30
2.12.2	Timer (TPM/FTM) Module Timing	31
2.12.3	SPI Characteristics	32
2.13	Flash Specifications	34
2.14	EMC Performance	35
2.14.1	Radiated Emissions	35
3	Ordering Information	36
4	Package Information	36
5	Mechanical Outline Drawings	37
5.1	80-pin LQFP Package	37
5.2	64-pin LQFP Package	40
5.3	64-pin QFP Package	43
5.4	48-pin LQFP Package	46
6	Revision History	48

List of Tables

Table 1.	MCF51AG128 Series Device Comparison	4
Table 2.	MCF51AG128 Series Functional Units	7
Table 3.	Pin Availability by Package Pin-Count	12
Table 4.	Parameter Classifications	14
Table 5.	Absolute Maximum Ratings	15
Table 6.	Thermal Characteristics	15
Table 7.	ESD and Latch-up Test Conditions	16
Table 9.	DC Characteristics	17

Table 8.	ESD and Latch-Up Protection Characteristics	17
Table 10.	Supply Current Characteristics	21
Table 11.	HSCMP Electrical Specifications	23
Table 12.	5V 12-bit ADC Operating Conditions	23
Table 13.	5 V 12-bit ADC Characteristics ($V_{REFH} = V_{DDA}$, $V_{REFL} = V_{SSA}$)	25
Table 14.	Oscillator Electrical Specifications (Temperature Range = -40 to 105 °C Ambient)	27
Table 15.	ICS Frequency Specifications (Temperature Range = -40 to 105 °C Ambient)	28
Table 16.	Control Timing	30
Table 17.	TPM/FTM Input Timing	31
Table 18.	SPI Timing Characteristics	32
Table 19.	Flash Characteristics	35
Table 20.	Orderable Part Number Summary	36
Table 21.	Package Descriptions	36
Table 22.	Revision History	48

List of Figures

Figure 1.	MCF51AG128 Series MCUs Block Diagram	6
Figure 2.	80-Pin LQFP	9
Figure 3.	64-Pin QFP and LQFP	10
Figure 4.	48-Pin LQFP	11
Figure 5.	Typical I_{OH} vs. $V_{DD} - V_{OH}$ (Low Drive, $PTxDSn = 0$)	19
Figure 6.	Typical I_{OH} vs. $V_{DD} - V_{OH}$ (High Drive, $PTxDSn = 1$)	19
Figure 7.	Typical I_{OL} vs. V_{OL} (Low Drive, $PTxDSn = 0$)	20
Figure 8.	Typical I_{OL} vs. V_{OL} (High Drive, $PTxDSn = 1$)	20
Figure 9.	Run Current at Different Conditions	22
Figure 10.	ADC Input Impedance Equivalency Diagram	25
Figure 11.	Reset Timing	30
Figure 12.	IRQ/KBIPx Timing	31
Figure 13.	Timer External Clock	31
Figure 14.	Timer Input Capture Pulse	31
Figure 15.	SPI Master Timing (CPHA = 0)	33
Figure 16.	SPI Master Timing (CPHA = 1)	33
Figure 17.	SPI Slave Timing (CPHA = 0)	34
Figure 18.	SPI Slave Timing (CPHA = 1)	34

1 MCF51AG128 Family Configurations

1.1 Device Comparison

The following table compares the various device derivatives available within the MCF51AG128 series MCUs.

Table 1. MCF51AG128 Series Device Comparison

Feature	MCF51AG128			MCF51AG96		
	80-pin	64-pin	48-pin	80-pin	64-pin	48-pin
Flash memory size (KB)	128			96		
RAM size (KB)	16					
ColdFire V1 core with BDM (background debug module)	Yes					
HSCMP (analog comparator)	2	2	1	2	2	1
ADC (analog-to-digital converter) channels (12-bit)	24	19	12	24	19	12
CRC (cyclic redundancy check)	Yes					
DAC	2	2	1	2	2	1
DMA controller	4-ch					
iEvent (intelligent Event module)	Yes					
EWM (External Watchdog Monitor)	Yes					
WDOG (Watchdog timer)	Yes					
RTC	Yes					
DBG (debug module)	Yes					
IIC (inter-integrated circuit)	1	1	No	1	1	No
IRQ (interrupt request input)	Yes					
INTC (interrupt controller)	Yes					
LVD (low-voltage detector)	Yes					
ICS (internal clock source)	Yes					
OSC (crystal oscillator)	Yes					
Port I/O ¹	69	53	39	69	53	39
RGPIO (rapid general-purpose I/O)	16	16	15	16	16	15
SCI (serial communications interface)	2					
SPI1 (serial peripheral interface)	Yes					
SPI2 (serial peripheral interface)	Yes	No	No	Yes	No	No
FTM1 (flexible timer module) channels	6 ²					
FTM2 channels	6 ²					

Table 1. MCF51AG128 Series Device Comparison (continued)

Feature	MCF51AG128			MCF51AG96		
	80-pin	64-pin	48-pin	80-pin	64-pin	48-pin
TPM3 (timer pulse-width modulator) channels	2					
Debug Visibility Bus	Yes	No	No	Yes	No	No

¹ Up to 16 pins on Ports E and F are shared with the ColdFire Rapid GPIO module.

² Some pins of FTMx might not be bonded on small package, therefore these channels could be used as soft timer only.

1.2 Block Diagram

Figure 1 shows the connections between the MCF51AG128 series pins and modules.

MCF51AG128 Family Configurations

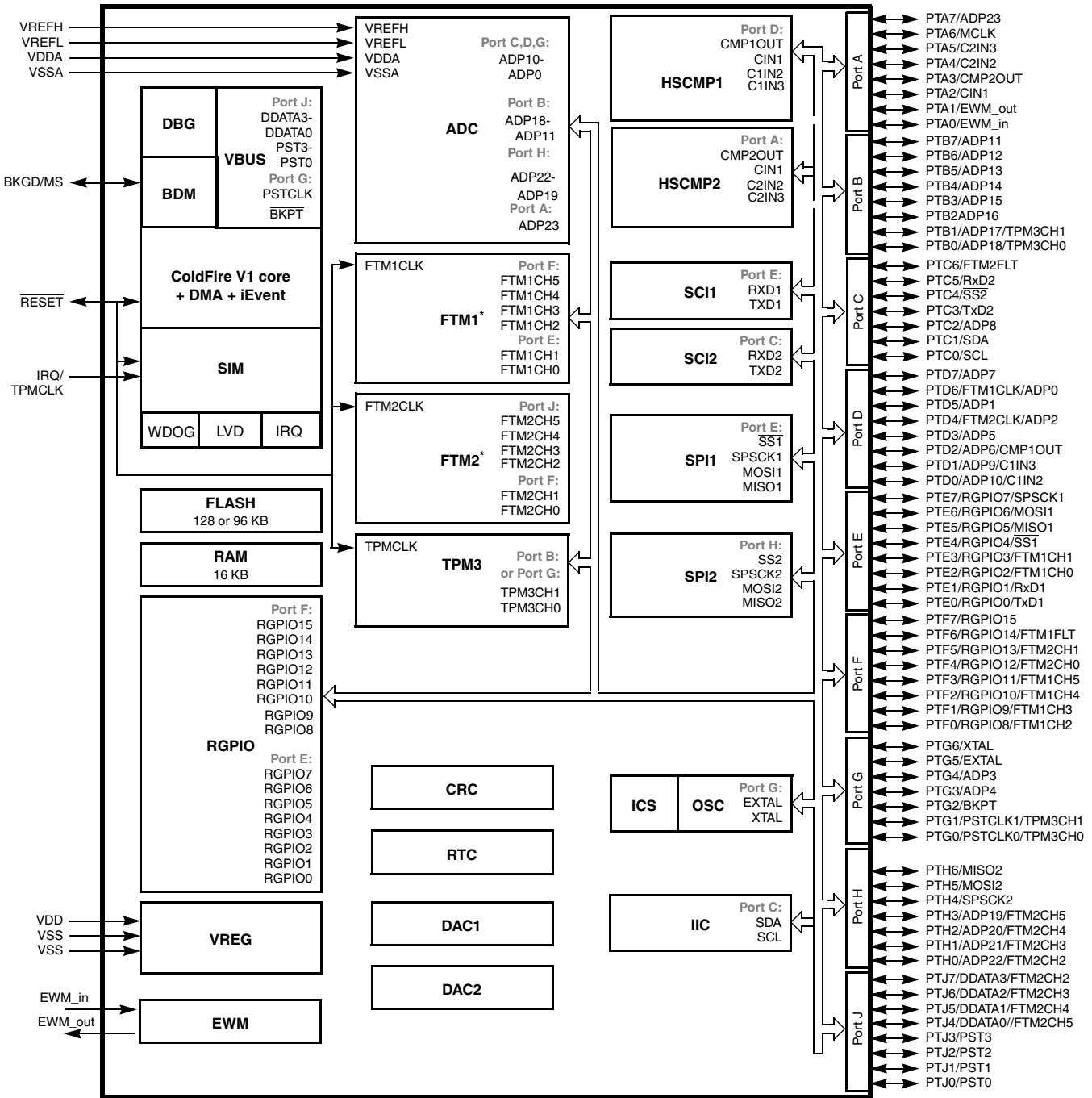

Figure 1. MCF51AG128 Series MCUs Block Diagram

1.3 Features

Table 2 describes the functional units of the MCF51AG128 series.

Table 2. MCF51AG128 Series Functional Units

Functional Unit	Function
CF1Core (V1 ColdFire core)	Executes programs and interrupt handlers
BDM (background debug module)	Provides single pin debugging interface (part of the V1 ColdFire core)
DBG (debug)	Provides debugging and emulation capabilities (part of the V1 ColdFire core)
VBUS (debug visibility bus)	Allows for real-time program traces (part of the V1 ColdFire core)
SIM (system integration module)	Controls resets and chip level interfaces between modules
Flash (flash memory)	Provides storage for program code, constants, and variables
RAM (random-access memory)	Provides storage for program variables
RGPIO (rapid general-purpose input/output)	Allows for I/O port access at CPU clock speeds
VREG (voltage regulator)	Controls power management across the device
LVD (low-voltage detect)	Monitors internal and external supply voltage levels, and generates a reset or interrupt when the voltages are too low
CF1_INTC (interrupt controller)	Controls and prioritizes all device interrupts
ADC (analog-to-digital converter)	Measures analog voltages at up to 12 bits of resolution
FTM1, FTM2 (flexible timer/pulse-width modulators)	Provide a variety of timing-based features
TPM3 (timer/pulse-width modulator)	Provides a variety of timing-based features
CRC (cyclic redundancy check)	Accelerates computation of CRC values for ranges of memory
HSCMP1, HSCMP2 (analog comparators)	Compare two analog inputs
DAC1, DAC2 (digital-to-analog converter)	Provide programmable voltage reference for HSCMPx
IIC (inter-integrated circuit)	Supports standard IIC communications protocol
ICS (internal clock source)	Provides clocking options for the device, including a frequency-locked loop (FLL) for multiplying slower reference clock sources
OSC (crystal oscillator)	Allows a crystal or ceramic resonator to be used as the system clock source or reference clock for the FLL
SCI1, SCI2 (serial communications interfaces)	Serial communications UARTs capable of supporting RS-232 and LIN protocols
SPI1, SPI2 (8/16-bit serial peripheral interfaces)	Provide 8/16-bit 4-pin synchronous serial interface
DMA	Provides the means to directly transfer data between system memory and I/O peripherals
iEvent	Highly programmable module for creating combinational boolean outputs for use as interrupt requests, DMA transfer requests, or hardware triggers
EWM (External Watchdog Monitor)	Additional watchdog system to help reset external circuits

Table 2. MCF51AG128 Series Functional Units (continued)

Functional Unit	Function
WDOG (Watchdog timer)	keeps a watch on the system functioning and resets it in case of its failure
RTC (Real Time Counter)	Provides a constant time-base with optional interrupt

1.4 Pin Assignments

This section describes the pin assignments for the available packages.

Figure 2 shows the pinout of the 80-pin LQFP.

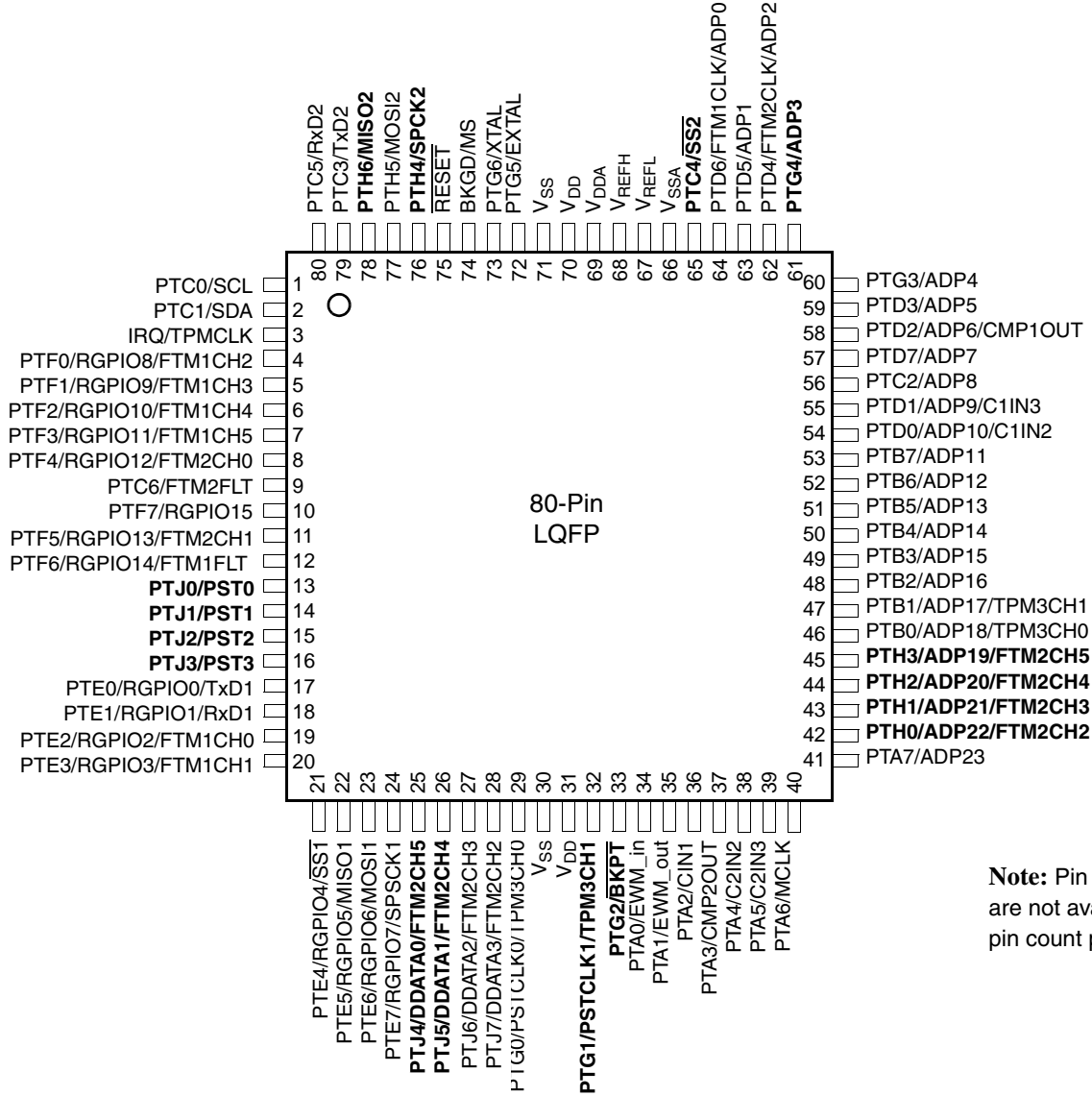

Note: Pin names in bold are not available in lower pin count packages.

Figure 2. 80-Pin LQFP

Figure 3 shows the pinout of the 64-pin LQFP and QFP.

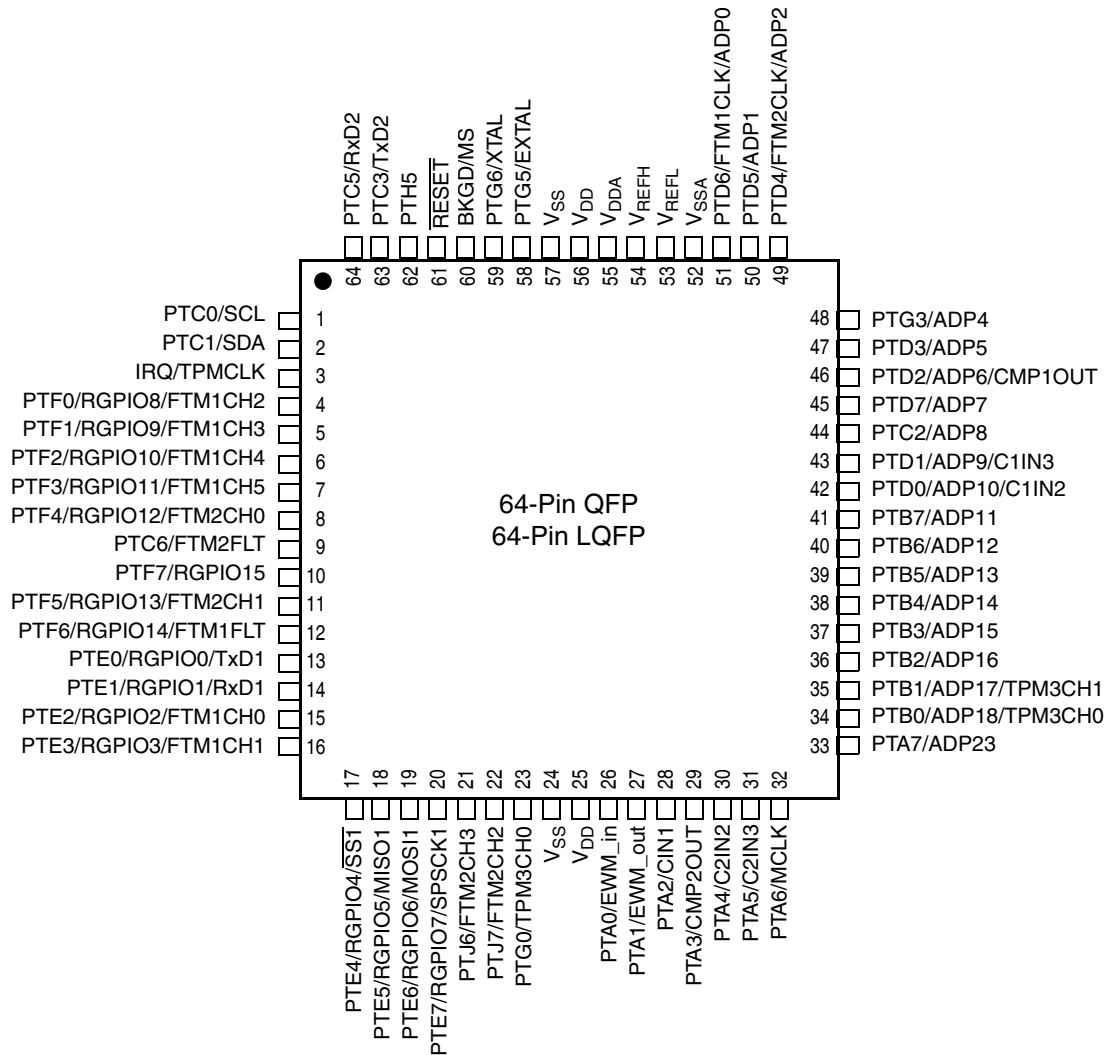

Figure 3. 64-Pin QFP and LQFP

Figure 4 shows the pinout of the 48-pin LQFP.

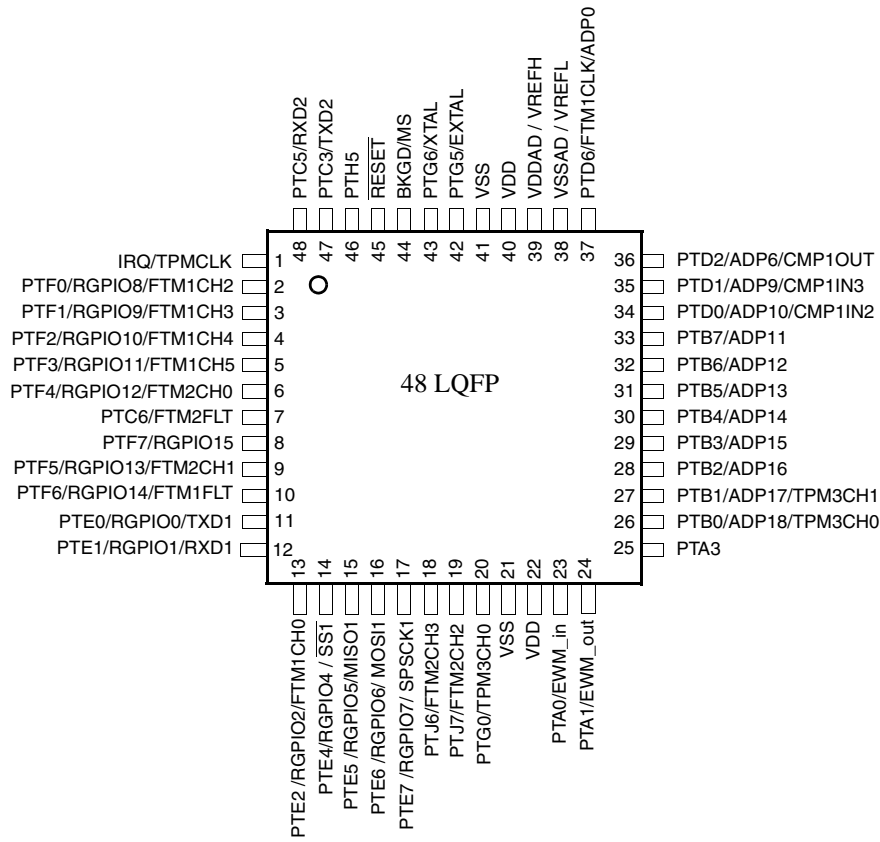

Figure 4. 48-Pin LQFP

Table 3 shows the package pin assignments.

Table 3. Pin Availability by Package Pin-Count

Pin Number			Lowest <-- Priority --> Highest		
80	64	48	Port Pin	Alt 1	Alt 2
1	1	—	PTC0	SCL	
2	2	—	PTC1	SDA	
3	3	1	IRQ	TPMCLK ¹	
4	4	2	PTF0	RGPIO8	FTM1CH2
5	5	3	PTF1	RGPIO9	FTM1CH3
6	6	4	PTF2	RGPIO10	FTM1CH4
7	7	5	PTF3	RGPIO11	FTM1CH5
8	8	6	PTF4	RGPIO12	FTM2CH0
9	9	7	PTC6	FTM2FLT	
10	10	8	PTF7	RGPIO15	
11	11	9	PTF5	RGPIO13	FTM2CH1
12	12	10	PTF6	RGPIO14	FTM1FLT
13	—	—	PTJ0	PST0	
14	—	—	PTJ1	PST1	
15	—	—	PTJ2	PST2	
16	—	—	PTJ3	PST3	
17	13	11	PTE0	RGPIO0	TxD1
18	14	12	PTE1	RGPIO1	RxD1
19	15	13	PTE2	RGPIO2	FTM1CH0
20	16	—	PTE3	RGPIO3	FTM1CH1
21	17	14	PTE4	RGPIO4	SS1
22	18	15	PTE5	RGPIO5	MISO1
23	19	16	PTE6	RGPIO6	MOSI1
24	20	17	PTE7	RGPIO7	SPSCK1
25	—	—	PTJ4	DDATA0	FTM2CH5
26	—	—	PTJ5	DDATA1	FTM2CH4
27	21	18	PTJ6	DDATA2	FTM2CH3
28	22	19	PTJ7	DDATA3	FTM2CH2
29	23	20	PTG0	PSTCLK0	TPM3CH0
30	24	21	V _{SS}		
31	25	22	V _{DD}		
32	—	—	PTG1	PSTCLK1	TPM3CH1
33	—	—	PTG2	BKPT	
34	26	23	PTA0	EWM_in	
35	27	24	PTA1	EWM_out	
36	28	—	PTA2	CIN1	
37	29	25	PTA3	CMP2OUT	
38	30	—	PTA4	C2IN2	
39	31	—	PTA5	C2IN3	
40	32	—	PTA6	MCLK	

Table 3. Pin Availability by Package Pin-Count (continued)

Pin Number			Lowest <-- Priority --> Highest		
80	64	48	Port Pin	Alt 1	Alt 2
41	33	—	PTA7	ADP23	
42	—	—	PTH0	ADP22	FTM2CH2
43	—	—	PTH1	ADP21	FTM2CH3
44	—	—	PTH2	ADP20	FTM2CH4
45	—	—	PTH3	ADP19	FTM2CH5
46	34	26	PTB0	ADP18	TPM3CH0
47	35	27	PTB1	ADP17	TPM3CH1
48	36	28	PTB2	ADP16	
49	37	29	PTB3	ADP15	
50	38	30	PTB4	ADP14	
51	39	31	PTB5	ADP13	
52	40	32	PTB6	ADP12	
53	41	33	PTB7	ADP11	
54	42	34	PTD0	ADP10	C1IN2
55	43	35	PTD1	ADP9	C1IN3
56	44	—	PTC2	ADP8	
57	45	—	PTD7	ADP7	
58	46	36	PTD2	ADP6	CMP1OUT
59	47	—	PTD3	ADP5	
60	48	—	PTG3	ADP4	
61	—	—	PTG4	ADP3	
62	49	—	PTD4	FTM2CLK	ADP2
63	50	—	PTD5	ADP1	
64	51	37	PTD6	FTM1CLK	ADP0
65	—	—	PTC4	$\overline{SS2}$	
66	52	38	V _{SSA}		
67	53	38	V _{REFL}		
68	54	39	V _{REFH}		
69	55	39	V _{DDA}		
70	56	40	V _{DD}		
71	57	41	V _{SS}		
72	58	42	PTG5	EXTAL	
73	59	43	PTG6	XTAL	
74	60	44	BKGD	MS	
75	61	45	\overline{RESET}		
76	—	—	PTH4	SPSCK2	
77	62	46	PTH5	MOSI2	
78	—	—	PTH6	MISO2	
79	63	47	PTC3	TxD2	
80	64	48	PTC5	RxD2	

¹ TPMCLK, FTM1CLK, and FTM2CLK options are configured via software; out of reset, FTM1CLK, FTM2CLK, and TPMCLK are available to FTM1, FTM2, and TPM3 respectively.

2 Preliminary Electrical Characteristics

This section contains electrical specification tables and reference timing diagrams for the MCF51AG128 series MCUs, including detailed information on power considerations, DC/AC electrical characteristics, and AC timing specifications.

The electrical specifications are preliminary and are from previous designs or design simulations. These specifications may not be fully tested or guaranteed at this early stage of the product life cycle. These specifications will, however, be met for production silicon. Finalized specifications will be published after complete characterization and device qualifications have been completed.

NOTE

The parameters specified in this data sheet supersede any values found in the module specifications.

2.1 Parameter Classification

The electrical parameters shown in this supplement are guaranteed by various methods. To give the customer a better understanding the following classification is used and the parameters are tagged accordingly in the tables where appropriate:

Table 4. Parameter Classifications

P	Those parameters are guaranteed during production testing on each individual device.
C	Those parameters are achieved by the design characterization by measuring a statistically relevant sample size across process variations.
T	Those parameters are achieved by design characterization on a small sample size from typical devices under typical conditions unless otherwise noted. All values shown in the typical column are within this category.
D	Those parameters are derived mainly from simulations.

NOTE

The classification is shown in the column labeled “C” in the parameter tables where appropriate.

2.2 Absolute Maximum Ratings

Absolute maximum ratings are stress ratings only, and functional operation at the maxima is not guaranteed. Stress beyond the limits specified in [Table 5](#) may affect device reliability or cause permanent damage to the device. For functional operating conditions, refer to the remaining tables in this section.

This device contains circuitry protecting against damage due to high static voltage or electrical fields; however, it is advised that normal precautions be taken to avoid application of any voltages higher than maximum-rated voltages to this high-impedance circuit. Reliability of operation is enhanced if unused inputs are tied to an appropriate logic voltage level (for instance, either V_{SS} or V_{DD}).

Table 5. Absolute Maximum Ratings

Rating	Symbol	Value	Unit
Supply voltage	V_{DD}	-0.3 to 5.8	V
Input voltage	V_{In}	-0.3 to $V_{DD} + 0.3$	V
Instantaneous maximum current Single pin limit (applies to all port pins) ^{1, 2, 3}	I_D	±25	mA
Maximum current into V_{DD}	I_{DD}	120	mA
Storage temperature	T_{stg}	-55 to 150	°C

¹ Input must be current limited to the value specified. To determine the value of the required current-limiting resistor, calculate resistance values for positive (V_{DD}) and negative (V_{SS}) clamp voltages, then use the larger of the two resistance values.

² All functional non-supply pins are internally clamped to V_{SS} and V_{DD} .

³ Power supply must maintain regulation within operating V_{DD} range during instantaneous and operating maximum current conditions. If positive injection current ($V_{In} > V_{DD}$) is greater than I_{DD} , the injection current may flow out of V_{DD} and could result in external power supply going out of regulation. Ensure external V_{DD} load will shunt current greater than maximum injection current. This will be the greatest risk when the MCU is not consuming power. Examples are: if no system clock is present, or if the clock rate is very low which would reduce overall power consumption.

2.3 Thermal Characteristics

This section provides information about operating temperature range, power dissipation, and package thermal resistance. Power dissipation on I/O pins is usually small compared to the power dissipation in on-chip logic and it is user-determined rather than being controlled by the MCU design. To take $P_{I/O}$ into account in power calculations, determine the difference between actual pin voltage and V_{SS} or V_{DD} and multiply by the pin current for each I/O pin. Except in cases of unusually high pin current (heavy loads), the difference between pin voltage and V_{SS} or V_{DD} is very small.

Table 6. Thermal Characteristics

Rating	Symbol	Value	Unit
Operating temperature range (packaged)	T_A	-40 to 105	°C
Maximum junction temperature	T_J	150	°C
Thermal resistance ^{1,2,3,4}			
80-pin LQFP	1s	56	°C/W
	2s2p	45	
64-pin QFP	1s	54	
	2s2p	41	
64-pin LQFP	1s	67	
	2s2p	49	
48-pin LQFP	1s	69	
	2s2p	51	

Preliminary Electrical Characteristics

- ¹ Junction temperature is a function of die size, on-chip power dissipation, package thermal resistance, mounting site (board) temperature, ambient temperature, air flow, power dissipation of other components on the board, and board thermal resistance.
- ² Junction to Ambient Natural Convection
- ³ 1s — Single layer board, one signal layer
- ⁴ 2s2p — Four layer board, 2 signal and 2 power layers

The average chip-junction temperature (T_J) in °C can be obtained from:

$$T_J = T_A + (P_D \times \theta_{JA}) \quad \text{Eqn. 1}$$

where:

T_A = Ambient temperature, °C

θ_{JA} = Package thermal resistance, junction-to-ambient, °C/W

$P_D = P_{int} + P_{I/O}$

$P_{int} = I_{DD} \times V_{DD}$, Watts — chip internal power

$P_{I/O}$ = Power dissipation on input and output pins — user determined

For most applications, $P_{I/O} \ll P_{int}$ and can be neglected. An approximate relationship between P_D and T_J (if $P_{I/O}$ is neglected) is:

$$P_D = K \div (T_J + 273 \text{ °C}) \quad \text{Eqn. 2}$$

Solving [Equation 1](#) and [Equation 2](#) for K gives:

$$K = P_D \times (T_A + 273 \text{ °C}) + \theta_{JA} \times (P_D)^2 \quad \text{Eqn. 3}$$

where K is a constant pertaining to the particular part. K can be determined from [Equation 3](#) by measuring P_D (at equilibrium) for a known T_A . Using this value of K, the values of P_D and T_J can be obtained by solving [Equation 1](#) and [Equation 2](#) iteratively for any value of T_A .

2.4 Electrostatic Discharge (ESD) Protection Characteristics

Although damage from static discharge is much less common on these devices than on early CMOS circuits, normal handling precautions should be used to avoid exposure to static discharge. Qualification tests are performed to ensure that these devices can withstand exposure to reasonable levels of static without suffering any permanent damage.

All ESD testing is in conformity with CDF-AEC-Q00 Stress Test Qualification for Automotive Grade Integrated Circuits. (<http://www.aecouncil.com/>) This device was qualified to AEC-Q100 Rev E.

A device is considered to have failed if, after exposure to ESD pulses, the device no longer meets the device specification requirements. Complete dc parametric and functional testing is performed per the applicable device specification at room temperature followed by hot temperature, unless specified otherwise in the device specification.

Table 7. ESD and Latch-up Test Conditions

Model	Description	Symbol	Value	Unit
Human Body	Series Resistance	R1	1500	Ω
	Storage Capacitance	C	100	pF
	Number of Pulse per pin	—	3	—

Table 7. ESD and Latch-up Test Conditions (continued)

Model	Description	Symbol	Value	Unit
Latch-up	Minimum input voltage limit	—	-2.5	V
	Maximum input voltage limit	—	7.5	V

Table 8. ESD and Latch-Up Protection Characteristics

Num	Rating	Symbol	Min	Max	Unit
1	Human Body Model (HBM)	V_{HBM}	±2000	—	V
2	Charge Device Model (CDM)	V_{CDM}	±500	—	V
3	Latch-up Current at $T_A = 85^\circ\text{C}$	I_{LAT}	±100	—	mA

2.5 DC Characteristics

This section includes information about power supply requirements, I/O pin characteristics, and power supply current in various operating modes.

Table 9. DC Characteristics

Num	C	Parameter	Symbol	Min	Typical ¹	Max	Unit
1	—	Operating voltage		2.7	—	5.5	V
2	P	Output high voltage — Low Drive (PTxDSn = 0) 5 V, $I_{Load} = -5$ mA 3 V, $I_{Load} = -1.5$ mA 5V, $I_{Load} = -3$ mA, PTC0 and PTC1 3V, $I_{Load} = -1.5$ mA, PTC0 and PTC1	V_{OH}	$V_{DD} - 1.5$	—	—	V
		$V_{DD} - 0.8$		—	—		
		Output high voltage — High Drive (PTxDSn = 1) 5 V, $I_{Load} = -20$ mA 3 V, $I_{Load} = -8$ mA 5V, $I_{Load} = -12$ mA, PTC0 and PTC1 3V, $I_{Load} = -8$ mA, PTC0 and PTC1		$V_{DD} - 1.5$	—	—	
				$V_{DD} - 0.8$	—	—	
				$V_{DD} - 0.4$	—	—	
				$V_{DD} - 0.4$	—	—	
3	P	Output low voltage — Low Drive (PTxDSn = 0) 5 V, $I_{Load} = 5$ mA 3 V, $I_{Load} = 1.5$ mA 5V, $I_{Load} = 3$ mA, PTC0 and PTC1 3V, $I_{Load} = 1.5$ mA, PTC0 and PTC1	V_{OL}	—	—	1.5	V
		—		—	0.8		
		Output low voltage — High Drive (PTxDSn = 1) 5 V, $I_{Load} = 20$ mA 3 V, $I_{Load} = 8$ mA 5V, $I_{Load} = 12$ mA, PTC0 and PTC1 3V, $I_{Load} = 8$ mA, PTC0 and PTC1		—	—	1.5	
				—	—	0.8	
				—	—	0.4	
				—	—	0.4	
4	C	Output high current — Max total I_{OH} for all ports 5V 3V	I_{OHT}	— —	— —	100 60	mA
5	C	Output low current — Max total I_{OL} for all ports 5 V 3 V	I_{OLT}	— —	— —	100 60	mA

Table 9. DC Characteristics (continued)

Num	C	Parameter	Symbol	Min	Typical ¹	Max	Unit	
6	P	Input high voltage; all digital inputs	V_{IH}	$0.65 \times V_{DD}$	—	—	V	
7	P	Input low voltage; all digital inputs	V_{IL}	—	—	$0.35 \times V_{DD}$		
8	D	Input hysteresis; all digital inputs	V_{hys}	$0.06 \times V_{DD}$	—	—	mV	
9	P	Input leakage current; input only pins ²	$ I_{In} $	—	0.1	1	μA	
10	P	High Impedance (off-state) leakage current ²	$ I_{OZ} $	—	0.1	1	μA	
11	P	Internal pullup resistors ³	R_{PU}	20	45	65	k Ω	
		Internal pullup resistors PTC0 and PTC1		10	22	32		
12	P	Internal pulldown resistors ⁴	R_{PD}	20	45	65	k Ω	
13	C	Input Capacitance; all non-supply pins	C_{In}	—	—	8	pF	
14	P	POR rearm voltage	V_{POR}	0.9	1.4	2.0	V	
15	D	POR rearm time	t_{POR}	10	—	—	μs	
16	P	Low-voltage detection threshold — high range	V_{LVD1}	V_{DD} falling	3.9	4.0	4.1	V
				V_{DD} rising	4.0	4.1	4.2	
17	P	Low-voltage detection threshold — low range	V_{LVD0}	V_{DD} falling	2.48	2.56	2.64	V
				V_{DD} rising	2.54	2.62	2.70	
18	P	Low-voltage warning threshold — high range 1	V_{LVW3}	V_{DD} falling	4.5	4.6	4.7	V
				V_{DD} rising	4.6	4.7	4.8	
19	P	Low-voltage warning threshold — high range 0	V_{LVW2}	V_{DD} falling	4.2	4.3	4.4	V
				V_{DD} rising	4.3	4.4	4.5	
20	P	Low-voltage warning threshold low range 1	V_{LVW1}	V_{DD} falling	2.84	2.92	3.00	V
				V_{DD} rising	2.90	2.98	3.06	
21	P	Low-voltage warning threshold — low range 0	V_{LVW0}	V_{DD} falling	2.66	2.74	2.82	V
				V_{DD} rising	2.72	2.80	2.88	
22	T	Low-voltage inhibit reset/recover hysteresis	V_{hys}	5 V	—	100	—	mV
				3 V	—	60	—	
23	D	RAM retention voltage	V_{RAM}	—	0.6	1.0	V	
24	D	DC injection current ^{5 6 7 8} (single pin limit)	I_{IC}	$V_{IN} > V_{DD}$	0	—	2	mA
				$V_{IN} < V_{SS}$	0	—	-0.2	
		DC injection current (Total MCU limit, includes sum of all stressed pins)		$V_{IN} > V_{DD}$	0	—	25	mA
				$V_{IN} < V_{SS}$	0	—	-5	

- ¹ Typical values are based on characterization data at 25°C unless otherwise stated.
- ² Measured with $V_{In} = V_{DD}$ or V_{SS} .
- ³ Measured with $V_{In} = V_{SS}$.
- ⁴ Measured with $V_{In} = V_{DD}$.
- ⁵ Power supply must maintain regulation within operating V_{DD} range during instantaneous and operating maximum current conditions. If positive injection current ($V_{In} > V_{DD}$) is greater than I_{DD} , the injection current may flow out of V_{DD} and could result in external power supply going out of regulation. Ensure external V_{DD} load will shunt current greater than maximum injection current. This will be the greatest risk when the MCU is not consuming power. Examples are: if no system clock is present, or if clock rate is very low (which would reduce overall power consumption).
- ⁶ All functional non-supply pins are internally clamped to V_{SS} and V_{DD} .
- ⁷ Input must be current limited to the value specified. To determine the value of the required current-limiting resistor, calculate resistance values for positive and negative clamp voltages, then use the larger of the two values.
- ⁸ The $\overline{\text{RESET}}$ pin does not have a clamp diode to V_{DD} . Do not drive this pin above V_{DD} .

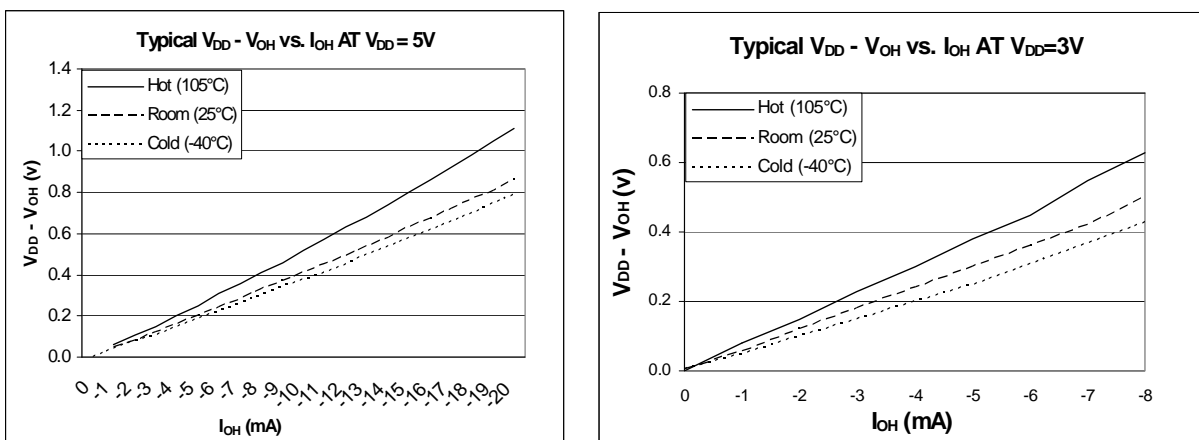
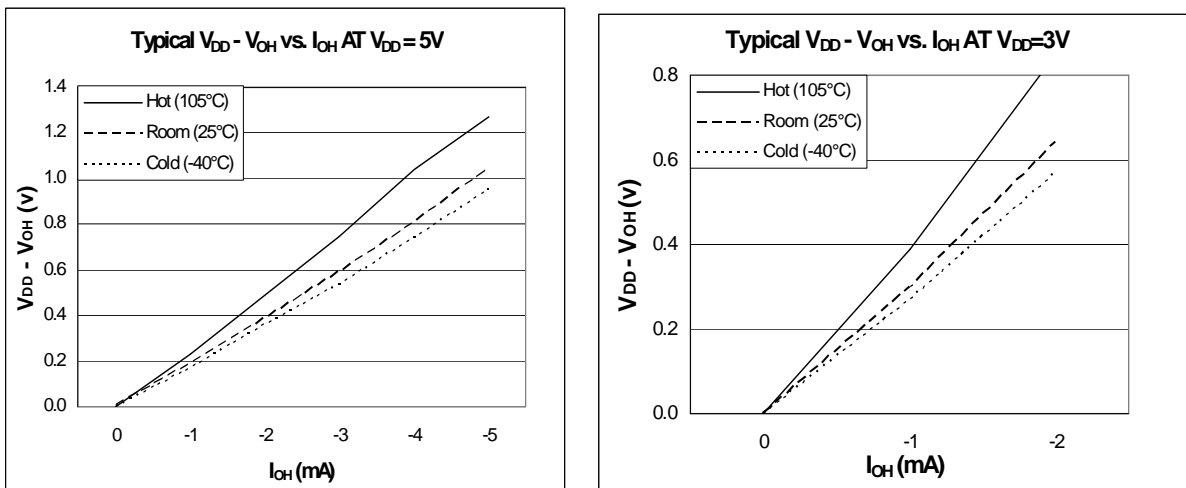

Figure 6. Typical I_{OH} vs. $V_{DD} - V_{OH}$ (High Drive, $PTxDSn = 1$)

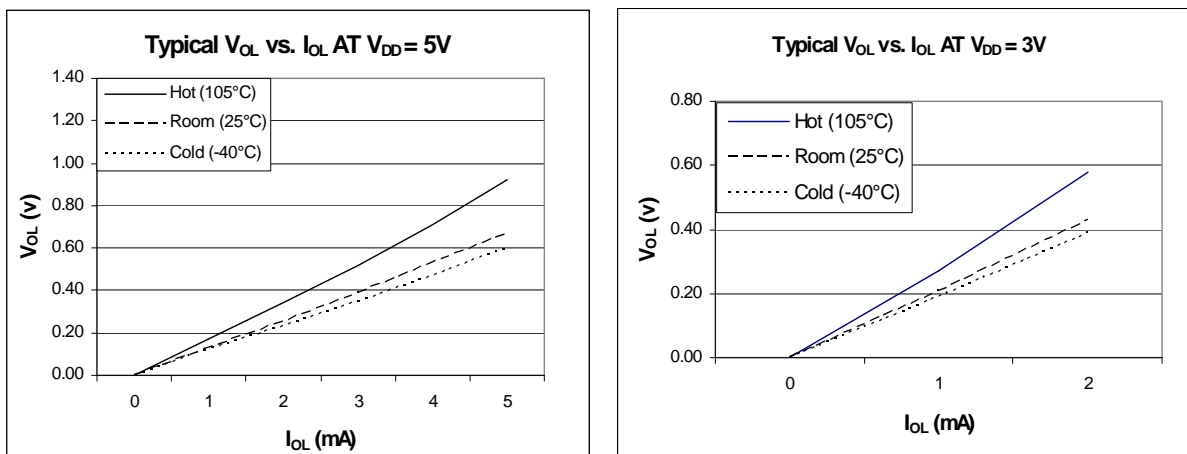

Figure 7. Typical I_{OL} vs. V_{OL} (Low Drive, $PTxDSn = 0$)

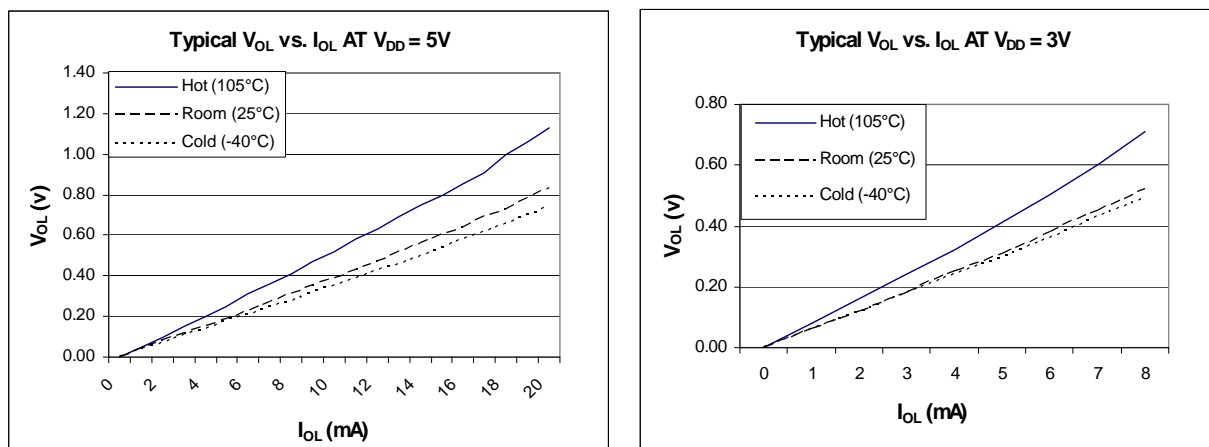

Figure 8. Typical I_{OL} vs. V_{OL} (High Drive, $PTxDSn = 1$)

2.6 Supply Current Characteristics

Table 10. Supply Current Characteristics

Num	C	Parameter	Symbol	V _{DD} (V)	Typical ¹	Max ²	Unit
1	C	Run supply current ³ measured at 4 MHz CPU clock (All Peripheral Clocks are ON)	R _I DD	5	5.8	7	mA
				3	5.7	7	
2	C	Run supply current ³ measured at 16 MHz CPU clock (All Peripheral Clocks are ON)	R _I DD	5	21	25	mA
				3	20.9	25	
3	C	Run supply current ³ measured at 32 MHz CPU clock (All Peripheral Clocks are ON)	R _I DD	5	39.2	50	mA
				3	39.1	50	
4	P	Run supply current ³ measured at 50MHz CPU clock (All Peripheral Clocks are ON)	R _I DD	5	57.9	70	mA
				3	57.8	70	
5	C	Run supply current ³ measured at 4 MHz CPU clock (All Peripheral Clocks are OFF ⁴)	R _I DD	5	4.7	6	mA
				3	4.6	6	
6	C	Run supply current ³ measured at 16 MHz CPU clock (All Peripheral Clocks are OFF ⁴)	R _I DD	5	16.1	20	mA
				3	15.9	20	
7	C	Run supply current ³ measured at 32 MHz CPU clock (All Peripheral Clocks are OFF ⁴)	R _I DD	5	29	35	mA
				3	28.9	35	
8	C	Run supply current ³ measured at 50 MHz CPU clock (All Peripheral Clocks are OFF ⁴)	R _I DD	5	44.1	50	mA
				3	44.0	50	
9	C	Wait supply current ³ measured at 4 MHz CPU clock	W _I DD	5	3.2	5	mA
				3	3.2	5	
10	C	Wait supply current ³ measured at 16 MHz CPU clock	W _I DD	5	10.1	13	mA
				3	10	13	
11	C	Wait supply current ³ measured at 32 MHz CPU clock	W _I DD	5	19	25	mA
				3	18.8	25	
12	C	Wait supply current ³ measured at 50 MHz CPU clock	W _I DD	5	29.2	40	mA
				3	29	40	
13	C	Stop2 mode supply current	S ₂ I _{DD}	5	1.17	3	μA
	P				1.35	3	
	C			28.6	40		
	C			1.0	3		
C	-40 °C	Stop2 mode supply current	S ₂ I _{DD}	3	1.34	3	μA
					P	1.34	
				C	26.8	40	

Table 10. Supply Current Characteristics

Num	C	Parameter	Symbol	V _{DD} (V)	Typical ¹	Max ²	Unit	
14	C P C	Stop3 mode supply current -40 °C 25 °C 105 °C	S3I _{DD}	5	1.2	3	μA	
					1.7	3		
					43.3	60		
	C P C			-40 °C 25 °C 105 °C	3	1.04	3	μA
						1.6	3	
						45.5	60	
15	C P C	Stop4 mode supply current -40 °C 25 °C 105 °C	S4I _{DD}	5	106	130	μA	
					109	130		
					155	170		
	C P C			-40 °C 25 °C 105 °C	3	95	130	μA
						98	130	
						142	170	
16	C	RTC adder to stop2 or stop3 ⁵ , 25 °C	S23I _{DDRTC}	5	300	—	nA	
				3	300	—	nA	
17	C	Adder to stop3 for oscillator enabled ⁶ (ERCLKEN = 1 and EREFSTEN = 1)	S3I _{DDOSC}	5, 3	5	—	μA	

¹ Typicals are measured at 25 °C.

² Values given here are preliminary estimates prior to completing characterization.

³ Code run from flash, FEI mode, and does not include any dc loads on port pins. Bus CLK= (CPU CLK/2)

⁴ GPIO filters are working on LPO clock.

⁵ Most customers are expected to use auto-wakeup from stop2 or stop3 instead of the higher current wait mode.

⁶ Values given under the following conditions: low range operation (RANGE = 0), low power mode (HGO = 0).

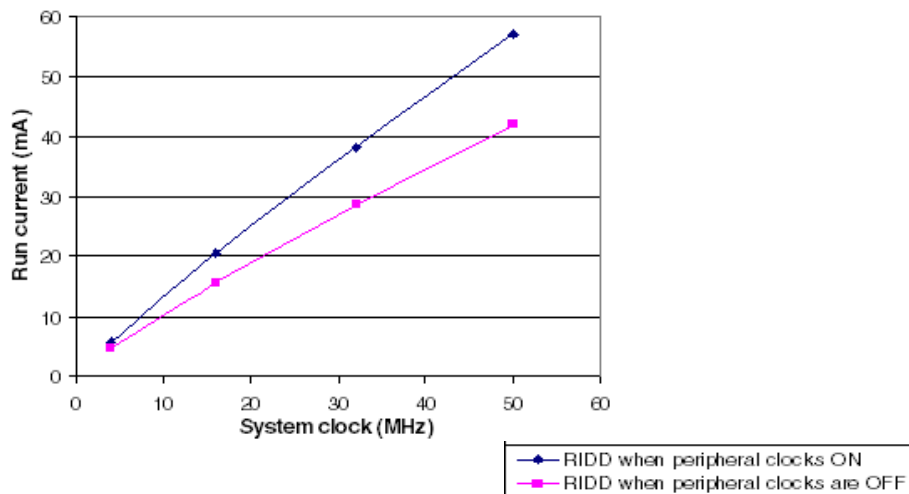

Figure 9. Run Current at Different Conditions

2.7 High Speed Comparator (HSCMP) Electricals

Table 11. HSCMP Electrical Specifications

Num	C	Rating	Symbol	Min	Typical	Max	Unit
1	—	Supply voltage	V_{DD}	2.7	—	5.5	V
2	T	Supply current, high speed mode (EN = 1, PMODE = 1)	I_{DDAHS}	—	200	—	μA
3	T	Supply current, low speed mode (EN = 1, PMODE = 0)	I_{DDALS}	—	20	—	μA
4	—	Analog input voltage	V_{AIN}	$V_{SS} - 0.3$	—	V_{DD}	V
5	D	Analog input offset voltage	V_{AIO}	—	5	40	mV
6	D	Analog Comparator hysteresis	V_H	3.0	9.0	20.0	mV
7	D	Propagation delay, high speed mode (EN = 1, PMODE = 1)	t_{DHS}	—	70	120	ns
8	D	Propagation delay, low speed mode (EN = 1, PMODE = 0)	t_{DLS}	—	400	600	ns
9	D	Analog Comparator initialization delay	t_{AINIT}	—	400	—	ns

2.8 Digital to Analog (DAC) Characteristics

Num	C	Rating	Symbol	Min	Typical	Max	Unit
1	D	Supply voltage	V_{DDA}	2.7	—	5.5	V
2	D	Supply current (enabled)	I_{DDAC}	—	—	20	μA
3	D	Supply current (stand-by)	I_{DDACS}	—	—	150	nA
4	D	DAC reference input voltage	V_{in1}, V_{in2}	V_{SSA}	—	V_{DDA}	V
5	D	DAC setup delay	t_{PRGST}	—	1000	—	nS
6	D	DAC step size	V_{step}	$3V_{in}/128$	$V_{in}/32$	$5V_{in}/128$	V
7	D	DAC output voltage range	V_{dacout}	$V_{in}/32$	—	V_{in}	V
8	P	Bandgap voltage reference factory trimmed at $V_{DD} = 5 V$, Temp = 25 °C	V_{BG}	1.18	1.20	1.21	V

2.9 ADC Characteristics

Table 12. 5V 12-bit ADC Operating Conditions

Num	C	Characteristic	Conditions	Symb	Min	Typical ¹	Max	Unit	Comment
1	D	Supply voltage	Absolute	V_{DDA}	2.7	—	5.5	V	—
			Delta to V_{DD} $(V_{DD} - V_{DDA})^2$	ΔV_{DDA}	-100	0	100	mV	—
2	D	Ground voltage	Delta to V_{SS} $(V_{SS} - V_{SSA})^2$	ΔV_{SSA}	-100	0	100	mV	—

Table 12. 5V 12-bit ADC Operating Conditions (continued)

Num	C	Characteristic	Conditions	Symb	Min	Typical ¹	Max	Unit	Comment
3	D	Ref Voltage High	—	V _{REFH}	2.7	V _{DDA}	V _{DDA}	V	—
4	D	Ref Voltage Low	—	V _{REFL}	V _{SSAD}	V _{SSA}	V _{SSA}	V	—
5	D	Input Voltage	—	V _{ADIN}	V _{REFL}	—	V _{REFH}	V	—
6	C	Input Capacitance	—	C _{ADIN}	—	4.5	5.5	pF	—
7	C	Input Resistance	—	R _{ADIN}	—	3	5	kΩ	—
8	C	Analog Source Resistance	12 bit mode f _{ADCK} > 4 MHz f _{ADCK} < 4 MHz	R _{AS}	—	—	2	kΩ	External to MCU
	10 bit mode f _{ADCK} > 4 MHz f _{ADCK} < 4 MHz		—		—	5			
	8 bit mode (all valid f _{ADCK})		—		—	10			
9	D	ADC Conversion Clock Freq.	High Speed (ADLPC = 0)	f _{ADCK}	0.4	—	8.0	MHz	—
	D		Low Power (ADLPC = 1)		0.4	—	4.0		—

¹ Typical values assume V_{DDA} = 5.0 V, Temp = 25 °C, f_{ADCK} = 1.0 MHz unless otherwise stated. Typical values are for reference only and are not tested in production.

² DC potential difference.

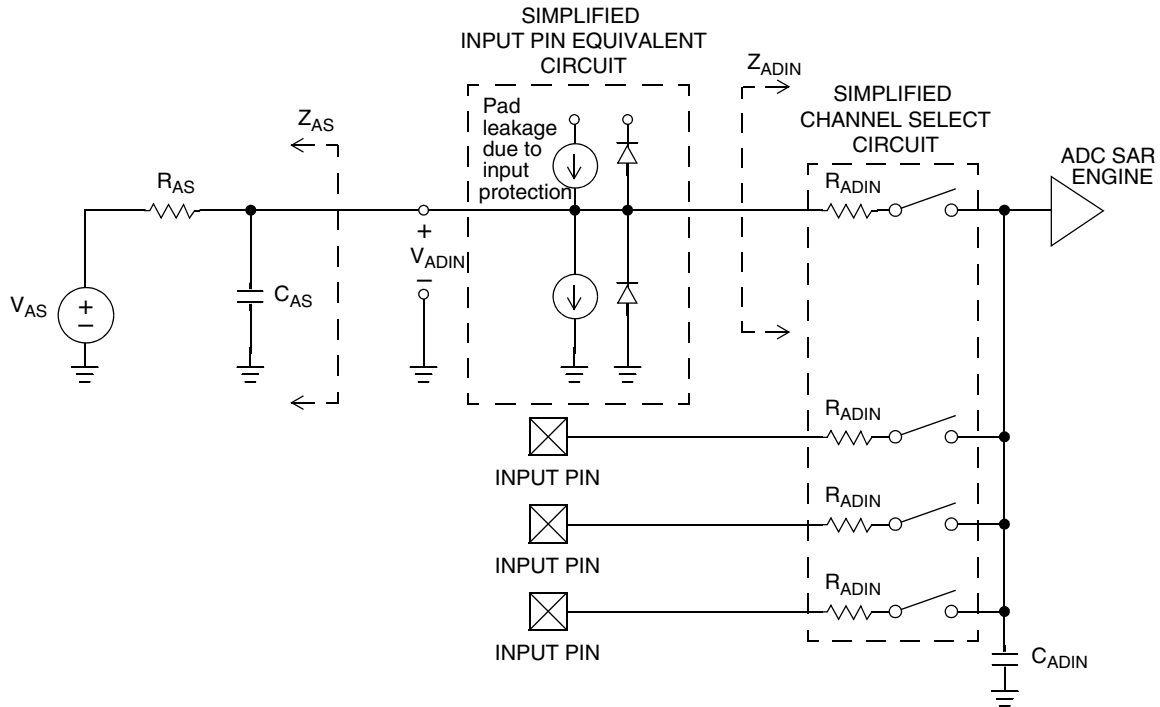

Figure 10. ADC Input Impedance Equivalency Diagram

Table 13. 5 V 12-bit ADC Characteristics ($V_{REFH} = V_{DDA}$, $V_{REFL} = V_{SSA}$)

Num	C	Characteristic	Conditions	Symb	Min	Typical ¹	Max	Unit	Comment
1	T	Supply Current ADLPC = 1 ADLSMP = 1 ADCO = 1	—	I_{DDAD}	—	181	—	μA	—
2	T	Supply Current ADLPC = 1 ADLSMP = 0 ADCO = 1	—	I_{DDAD}	—	334	—	μA	—
3	T	Supply Current ADLPC = 0 ADLSMP = 1 ADCO = 1	—	I_{DDAD}	—	385	—	μA	—
4	D	Supply Current ADLPC = 0 ADLSMP = 0 ADCO = 1	—	I_{DDAD}	—	0.717	1	mA	—
5	T	Supply Current	Stop, Reset, Module Off	I_{DDAD}	—	0.065	1	μA	—

Table 13. 5 V 12-bit ADC Characteristics ($V_{REFH} = V_{DDA}$, $V_{REFL} = V_{SSA}$) (continued)

Num	C	Characteristic	Conditions	Symb	Min	Typical ¹	Max	Unit	Comment
6	P	ADC Asynchronous Clock Source	High Speed (ADLPC = 0)	f_{ADACK}	2	3.3	5	MHz	$t_{ADACK} = 1/f_{ADACK}$
			Low Power (ADLPC = 1)		1.25	2	3.3		
7	P	Conversion Time (Including sample time)	Short Sample (ADLSMP = 0)	t_{ADC}	—	20	—	ADCK cycles	See Table 10 for conversion time variances
			Long Sample (ADLSMP = 1)		—	40	—		
8	T	Sample Time	Short Sample (ADLSMP = 0)	t_{ADS}	—	3.5	—	ADCK cycles	
			Long Sample (ADLSMP = 1)		—	23.5	—		
9	T	Total Unadjusted Error	12 bit mode	E_{TUE}	—	± 3.0	—	LSB ²	Includes quantization
	P		10 bit mode		—	± 1	± 2.5		
	T		8 bit mode		—	± 0.5	± 1.0		
10	T	Differential Non-Linearity	12 bit mode	DNL	—	± 1.75	—	LSB ²	—
	P		10 bit mode ³		—	± 0.5	± 1.0		
	T		8 bit mode ⁵		—	± 0.3	± 0.5		
11	T	Integral Non-Linearity	12 bit mode	INL	—	± 1.5	—	LSB ²	—
	P		10 bit mode		—	± 0.5	± 1.0		
	T		8 bit mode		—	± 0.3	± 0.5		
12	T	Zero-Scale Error	12 bit mode	E_{ZS}	—	± 1.5	—	LSB ²	$V_{ADIN} = V_{SSAD}$
	P		10 bit mode		—	± 0.5	± 1.5		
	T		8 bit mode		—	± 0.5	± 0.5		
13	T	Full-Scale Error	12 bit mode	E_{FS}	—	± 1	—	LSB ²	$V_{ADIN} = V_{DDAD}$
	P		10 bit mode		—	± 0.5	± 1		
	T		8 bit mode		—	± 0.5	± 0.5		
14	D	Quantization Error	12 bit mode	E_Q	—	-1 to 0	—	LSB ²	—
			10 bit mode		—	—	± 0.5		
			8 bit mode		—	—	± 0.5		
15	D	Input Leakage Error	12 bit mode	E_{IL}	—	± 1	—	LSB ²	Pad leakage ⁴ * R_{AS}
			10 bit mode		—	± 0.2	± 2.5		
			8 bit mode		—	± 0.1	± 1		

Table 13. 5 V 12-bit ADC Characteristics ($V_{REFH} = V_{DDA}$, $V_{REFL} = V_{SSA}$) (continued)

Num	C	Characteristic	Conditions	Symb	Min	Typical ¹	Max	Unit	Comment
16	D	Temp Sensor Voltage	25 °C	V_{TEMP25}	—	1.396	—	mV	—
17	D	Temp Sensor Slope	−40 °C — 25 °C	m	—	3.266	—	mV/°C	—
			25 °C — 85 °C		—	3.638	—		

¹ Typical values assume $V_{DDA} = 5.0$ V, Temp = 25 °C, $f_{ADCK} = 1.0$ MHz unless otherwise stated. Typical values are for reference only and are not tested in production.

² $1 \text{ LSB} = (V_{REFH} - V_{REFL})/2^N$

³ Monotonicity and No-Missing-Codes guaranteed in 10 bit and 8 bit modes

⁴ Based on input pad leakage current. Refer to pad electricals.

2.10 External Oscillator (XOSC) Characteristics

Table 14. Oscillator Electrical Specifications (Temperature Range = −40 to 105 °C Ambient)

Num	C	Rating	Symbol	Min	Typical ¹	Max	Unit
1	C	Oscillator crystal or resonator (EREFS = 1, ERCLKEN = 1)	f_{lo} f_{hi} f_{hi-hgo} f_{hi-lp}	32 1 1 1	— — — —	38.4 16 16 8	kHz MHz MHz MHz
		Low range (RANGE = 0)					
		High range (RANGE = 1) FEE or FBE mode ²					
		High range (RANGE = 1, HGO = 1) FBELP mode					
2	—	Load capacitors	C_1 C_2	See crystal or resonator manufacturer's recommendation.			
3	—	Feedback resistor	R_F		10 1	—	MΩ
4	—	Series resistor	R_S				kΩ
		Low range, low gain (RANGE = 0, HGO = 0)					
		Low range, high gain (RANGE = 0, HGO = 1)					
		High range, low gain (RANGE = 1, HGO = 0)					
		High range, high gain (RANGE = 1, HGO = 1)					
≥ 8 MHz							
4 MHz							
1 MHz							
5	T	Crystal start-up time ³	$t_{CSTL-LP}$ $t_{CSTL-HGO}$ $t_{CSTH-LP}$ $t_{CSTH-HGO}$				ms
		Low range, low gain (RANGE = 0, HGO = 0)					
		Low range, high gain (RANGE = 0, HGO = 1)					
		High range, low gain (RANGE = 1, HGO = 0) ⁴					
		High range, high gain (RANGE = 1, HGO = 1) ³					
6	T	Square wave input clock frequency (EREFS = 0, ERCLKEN = 1)	f_{extal}	0.03125 0 0	— — —	50.33 50.33 50.33	MHz
		FEE mode ²					
		FBE mode ²					
		FBELP mode					

¹ Data in Typical column was characterized at 5.0 V, 25 °C or is typical recommended value.

Preliminary Electrical Characteristics

- ² When MCG is configured for FEE or FBE mode, input clock source must be divisible using RDIV to within the range of 31.25 kHz to 39.0625 kHz.
- ³ This parameter is characterized and not tested on each device. Proper PC board layout procedures must be followed to achieve specifications.
- ⁴ 4 MHz crystal

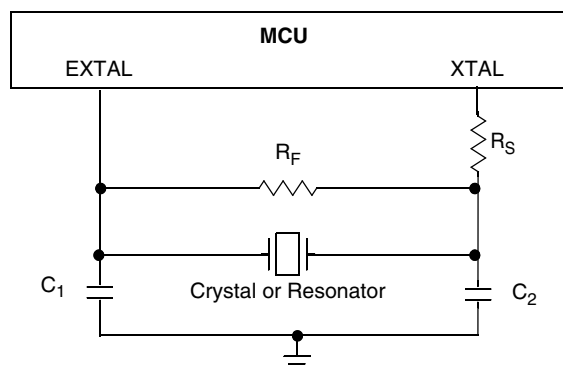

2.11 ICS Specifications

Table 15. ICS Frequency Specifications (Temperature Range = –40 to 105 °C Ambient)

Num	C	Rating	Symbol	Min	Typical ¹	Max	Unit	
1	C	Internal reference frequency - factory trimmed at V _{DD} = 5 V and temperature = 25 °C	f _{int_ft}	—	32.768	—	kHz	
2	C	Average internal reference frequency – untrimmed	f _{int_ut}	31.25	—	39.06	kHz	
3	T	Internal reference startup time	t _{irefst}	—	60	100	μs	
4	C	DCO output frequency range - untrimmed ²	f _{dco_ut}	Low range (DRS = 00)	16	—	20	MHz
	C			Mid range (DRS = 01)	32	—	40	
	C			High range (DRS = 10)	48	—	60	
5	P	DCO output frequency ² Reference = 32768Hz and DMX32 = 1	f _{dco_DM32}	Low range (DRS = 00)	—	16.82	—	MHz
	P			Mid range (DRS = 01)	—	33.69	—	
	P			High range (DRS = 10)	—	50.48	—	
6	D	Resolution of trimmed DCO output frequency at fixed voltage and temperature (using FTRIM)	Δf _{dco_res_t}	—	±0.1	±0.2	%f _{dco}	
7	D	Resolution of trimmed DCO output frequency at fixed voltage and temperature (not using FTRIM)	Δf _{dco_res_t}	—	±0.2	±0.4	%f _{dco}	
8	D	Total deviation of trimmed DCO output frequency over full voltage and temperature range	Δf _{dco_t}	—	0.5 –1.0	±2	%f _{dco}	
9	D	Total deviation of trimmed DCO output frequency over fixed voltage and temperature range of 0 –70 °C	Δf _{dco_t}	—	±0.5	±1	%f _{dco}	

Table 15. ICS Frequency Specifications (continued)(Temperature Range = –40 to 105 °C Ambient)

Num	C	Rating	Symbol	Min	Typical ¹	Max	Unit
10	D	FLL acquisition time ³	$t_{fill_acquire}$	—	—	1	ms
11	D	Long term Jitter of DCO output clock (averaged over 2ms interval) ⁴	C_{Jitter}	—	0.02	0.2	% f_{dco}
12	D	Loss of external clock minimum freq. (RANGE = 0) <ul style="list-style-type: none"> • ext. clock freq: above $(3/5)f_{int}$, never reset • ext. clock freq: between $(2/5)f_{int}$ and $(3/5)f_{int}$, maybe reset (phase dependency) • ext. clock freq: below $(2/5)f_{int}$, always reset 	f_{loc_low}	$(3/5) \times f_{int}$	—	—	kHz
13	D	Loss of external clock minimum freq. (RANGE = 1) <ul style="list-style-type: none"> • ext. clock freq: above $(16/5)f_{int}$, never reset • ext. clock freq: between $(15/5)f_{int}$ and $(16/5)f_{int}$, maybe reset (phase dependency) • ext. clock freq: below $(15/5)f_{int}$, always reset 	f_{loc_high}	$(16/5) \times f_{int}$	—	—	kHz

¹ Data in Typical column was characterized at 3.0 V, 25 °C or is typical recommended value

² The resulting bus clock frequency should not exceed the maximum specified bus clock frequency of the device.

³ This specification applies to any time the FLL reference source or reference divider is changed, trim value changed or changing from FLL disabled (BLPE, BLPI) to FLL enabled (FEI, FEE, FBE, FBI). If a crystal/resonator is being used as the reference, this specification assumes it is already running.

⁴ Jitter is the average deviation from the programmed frequency measured over the specified interval at maximum f_{BUS} . Measurements are made with the device powered by filtered supplies and clocked by a stable external clock signal. Noise injected into the FLL circuitry by V_{DD} and V_{SS} and variation in crystal oscillator frequency increase the C_{Jitter} percentage for a given interval.

2.12 AC Characteristics

This section describes ac timing characteristics for each peripheral system.

2.12.1 Control Timing

Table 16. Control Timing

Num	C	Parameter	Symbol	Min	Typ ¹	Max	Unit
1	D	Bus frequency ($t_{cyc} = 1/f_{Bus}$)	f_{Bus}	dc	—	24	MHz
2	D	Internal low-power oscillator period	t_{LPO}	800	—	1500	μ s
3	D	External reset pulse width ² ($t_{cyc} = 1/f_{Self_reset}$)	t_{extrst}	100	—	—	ns
4	D	Reset low drive	t_{rstdrv}	$66 \times t_{cyc}$	—	—	ns
5	D	Active background debug mode latch setup time	t_{MSSU}	500	—	—	ns
6	D	Active background debug mode latch hold time	t_{MSH}	100	—	—	ns
7	D	IRQ pulse width Asynchronous path ² Synchronous path ³	t_{ILIH}, t_{IHIL}	100 $1.5 \times t_{cyc}$	—	—	ns
8		Port rise and fall time (load = 30 pF for SPI, rest 50 pF) ⁴ Slew rate control disabled (PTxSE = 0) High drive Slew rate control enabled (PTxSE = 1) High drive Slew rate control disabled (PTxSE = 0) Low drive Slew rate control enabled (PTxSE = 1) Low drive	t_{Rise}, t_{Fall}	— —	11 35 40 75		ns

¹ Typical values are based on characterization data at $V_{DD} = 5.0$ V, 25 °C unless otherwise stated.

² This is the shortest pulse that is guaranteed to be recognized as a \overline{RESET} pin request. Shorter pulses are not guaranteed to override reset requests from internal sources.

³ This is the minimum pulse width that is guaranteed to pass through the pin synchronization circuitry. Shorter pulses may or may not be recognized. In stop mode, the synchronizer is bypassed so shorter pulses can be recognized in that case.

⁴ Timing is shown with respect to 20% V_{DD} and 80% V_{DD} levels. Temperature range -40°C to 105°C .



Figure 11. Reset Timing

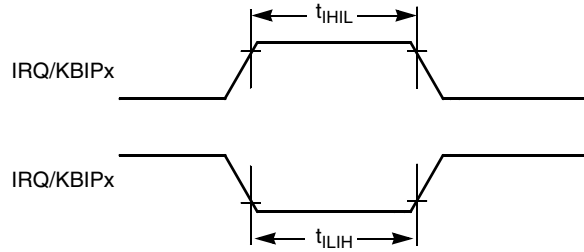

Figure 12. IRQ/KBIPx Timing

2.12.2 Timer (TPM/FTM) Module Timing

Synchronizer circuits determine the shortest input pulses that can be recognized or the fastest clock that can be used as the optional external source to the timer counter. These synchronizers operate from the current bus rate clock.

Table 17. TPM/FTM Input Timing

NUM	C	Function	Symbol	Min	Max	Unit
1	—	External clock frequency	f_{TPMext}	DC	$f_{Bus}/4$	MHz
2	—	External clock period	t_{TPMext}	4	—	t_{cyc}
3	D	External clock high time	t_{clkh}	1.5	—	t_{cyc}
4	D	External clock low time	t_{clkl}	1.5	—	t_{cyc}
5	D	Input capture pulse width	t_{ICPW}	1.5	—	t_{cyc}

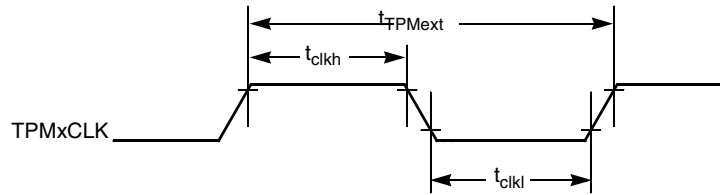

Figure 13. Timer External Clock

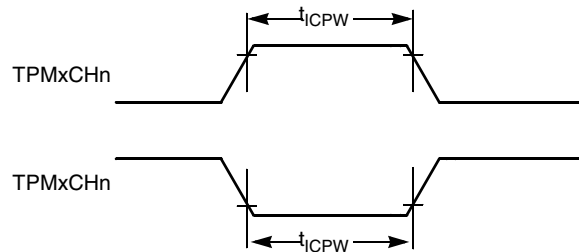

Figure 14. Timer Input Capture Pulse

2.12.3 SPI Characteristics

Table 18 and Figure 15 through Figure 18 describe the timing requirements for the SPI system.

Table 18. SPI Timing Characteristics

No.	C	Function	Symbol	Min	Max	Unit
—	D	Operating frequency Master Slave	f_{op}	$f_{Bus}/2048$ 0	$f_{Bus}/2$ $f_{Bus}/4$	Hz
1	D	SPSCK period Master Slave	t_{SPSCK}	2 4	2048 —	t_{cyc} t_{cyc}
2	D	Enable lead time Master Slave	t_{Lead}	1/2 1	— —	t_{SPSCK} t_{cyc}
3	D	Enable lag time Master Slave	t_{Lag}	1/2 1	— —	t_{SPSCK} t_{cyc}
4	D	Clock (SPSCK) high or low time Master Slave	t_{WSPSCK}	$t_{cyc} - 30$ $t_{cyc} - 30$	$1024 t_{cyc}$ —	ns ns
5	D	Data setup time (inputs) Master Slave	t_{SU}	30 30	— —	ns ns
6	D	Data hold time (inputs) Master Slave	t_{HI}	10 10	— —	ns ns
7	D	Slave access time	t_a	—	—	t_{cyc}
8	D	Slave MISO disable time	t_{dis}	—	—	t_{cyc}
9	D	Data valid time (maximum delay after SPCLK edge to Data output) Master Slave	t_V^1	— —	25 70	ns ns
10	D	Data hold time (minimum delay after SPCLK edge to Data output) Master Slave	t_{HO}^1	10 10	— —	ns ns

¹ SPI Output Load = 30 pf

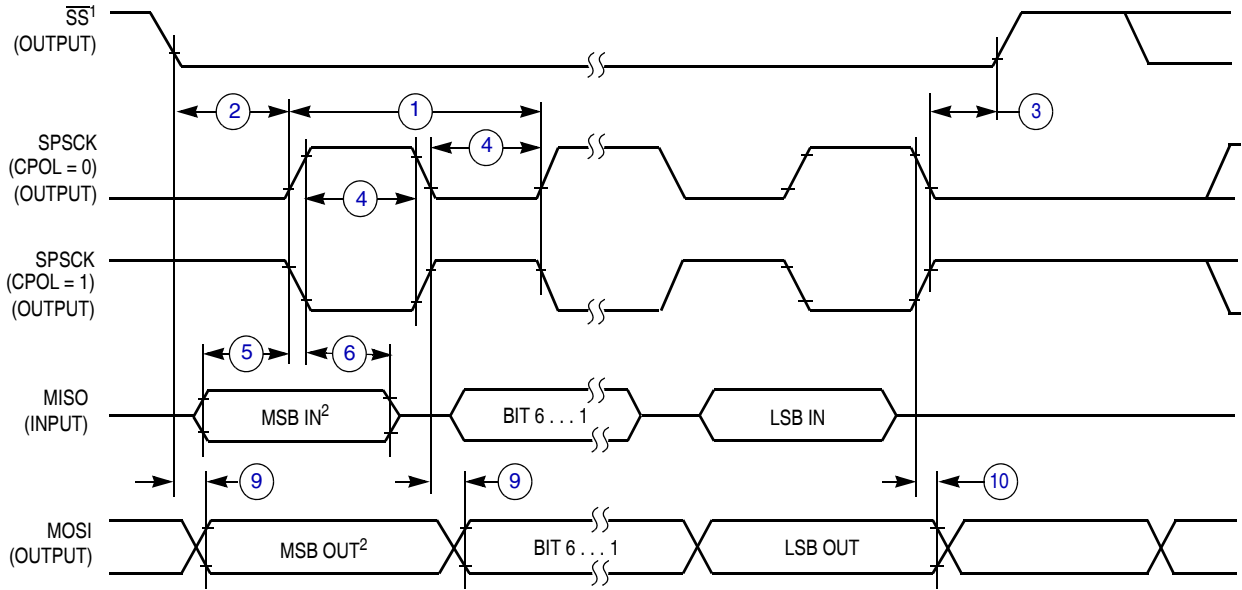

NOTES:

1. \overline{SS} output mode (DDS7 = 1, SSOE = 1).
2. LSBF = 0. For LSBF = 1, bit order is LSB, bit 1, ..., bit 6, MSB.

Figure 15. SPI Master Timing (CPHA = 0)

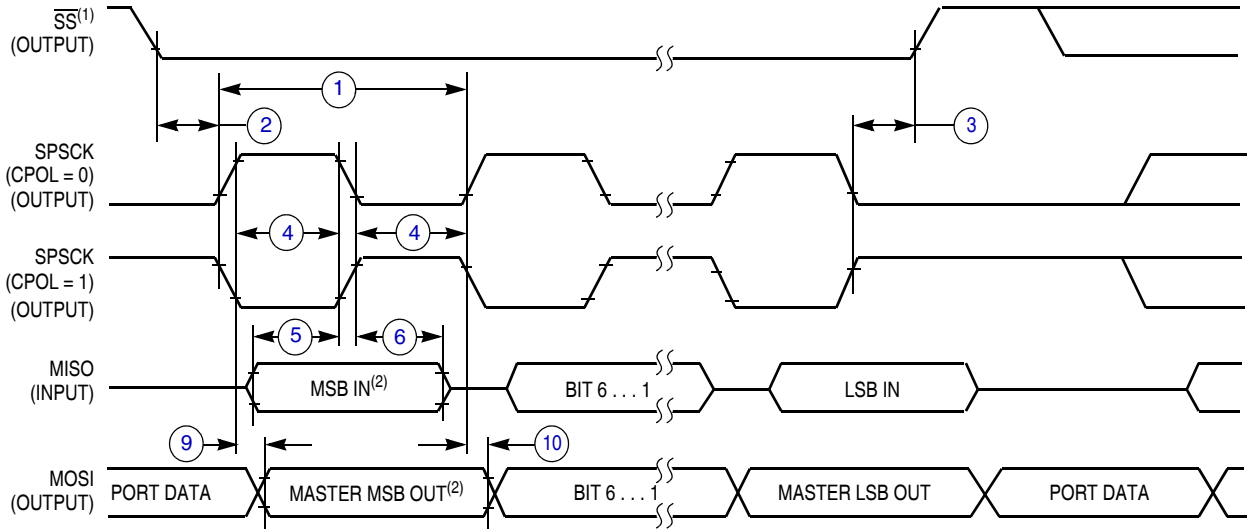

NOTES:

1. \overline{SS} output mode (DDS7 = 1, SSOE = 1).
2. LSBF = 0. For LSBF = 1, bit order is LSB, bit 1, ..., bit 6, MSB.

Figure 16. SPI Master Timing (CPHA = 1)

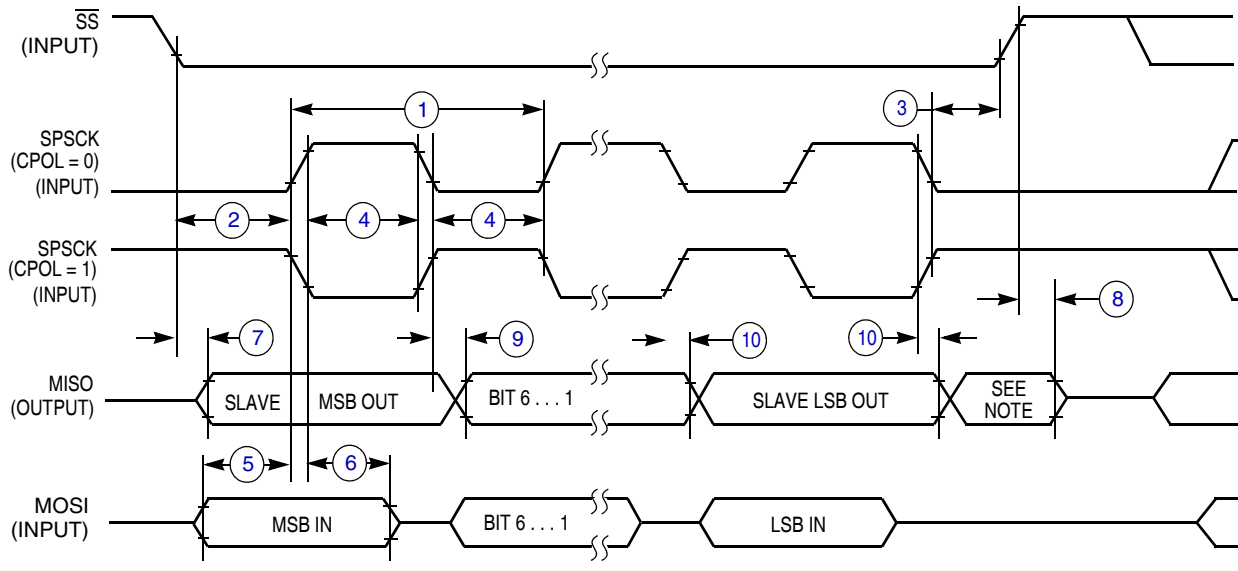

NOTE:

1. Not defined but normally MSB of character just received

Figure 17. SPI Slave Timing (CPHA = 0)

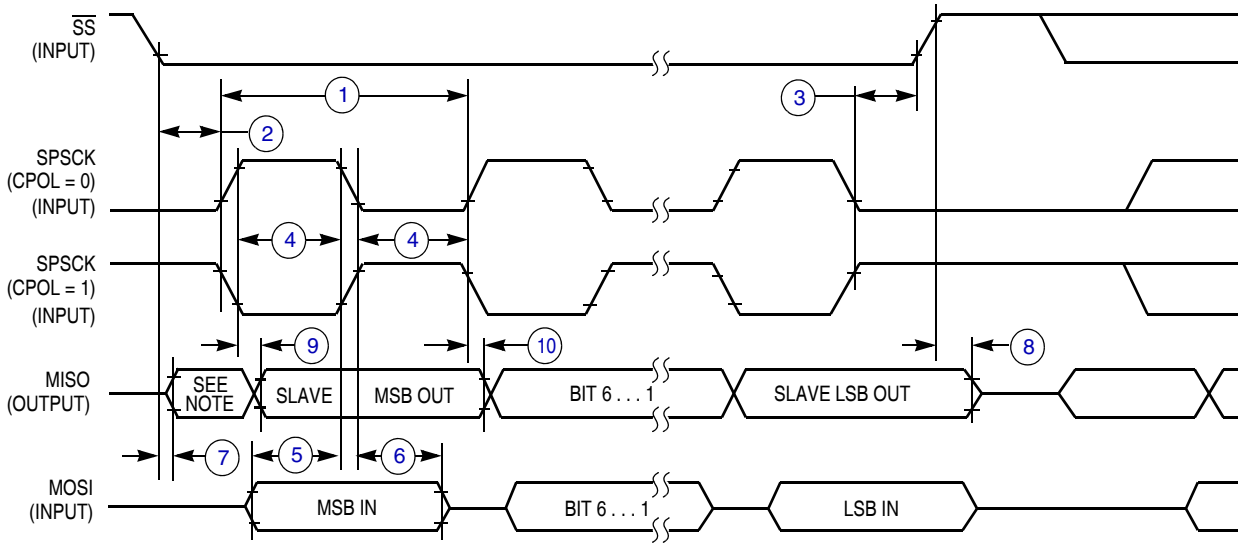

NOTE:

1. Not defined but normally LSB of character just received

Figure 18. SPI Slave Timing (CPHA = 1)

2.13 Flash Specifications

This section provides details about program/erase times and program-erase endurance for the Flash memory.

Program and erase operations do not require any special power sources other than the normal V_{DD} supply. For more detailed information about program/erase operations, see *MCF51AG128 Reference Manual*.

Table 19. Flash Characteristics

Num	C	Characteristic	Symbol	Min	Typical ¹	Max	Unit
1	—	Supply voltage for program/erase	$V_{\text{prog/erase}}$	2.7		5.5	V
2	—	Supply voltage for read operation	V_{Read}	2.7		5.5	V
3	—	Internal FCLK frequency ²	f_{FCLK}	150		200	kHz
4	—	Internal FCLK period (1/FCLK)	t_{Fcyt}	5		6.67	μs
5	—	Byte program time (random location) ²	t_{prog}	9			t_{Fcyt}
6	—	Byte program time (burst mode) ²	t_{Burst}	4			t_{Fcyt}
7	—	Page erase time ³	t_{Page}	4000			t_{Fcyt}
8	—	Mass erase time ²	t_{Mass}	20,000			t_{Fcyt}
9	C	Program/erase endurance ⁴ T_L to $T_H = -40\text{ }^\circ\text{C}$ to $105\text{ }^\circ\text{C}$ $T = 25\text{ }^\circ\text{C}$		10,000 —	— 100,000	— —	cycles
10	C	Data retention ⁵	$t_{\text{D_ret}}$	15	100	—	years

¹ Typical values are based on characterization data at $V_{\text{DD}} = 5.0\text{ V}$, $25\text{ }^\circ\text{C}$ unless otherwise stated.

² The frequency of this clock is controlled by a software setting.

³ These values are hardware state machine controlled. User code does not need to count cycles. This information supplied for calculating approximate time to program and erase.

⁴ **Typical endurance for flash** was evaluated for this product family on the HC9S12Dx64. For additional information on how Freescale Semiconductor defines typical endurance, please refer to Engineering Bulletin EB619/D, *Typical Endurance for Nonvolatile Memory*.

⁵ **Typical data retention** values are based on intrinsic capability of the technology measured at high temperature and de-rated to $25\text{ }^\circ\text{C}$ using the Arrhenius equation. For additional information on how Freescale Semiconductor defines typical data retention, please refer to Engineering Bulletin EB618/D, *Typical Data Retention for Nonvolatile Memory*.

2.14 EMC Performance

Electromagnetic compatibility (EMC) performance is highly dependant on the environment in which the MCU resides. Board design and layout, circuit topology choices, location and characteristics of external components as well as MCU software operation all play a significant role in EMC performance. The system designer should consult Freescale applications notes such as AN2321, AN1050, AN1263, AN2764, and AN1259 for advice and guidance specifically targeted at optimizing EMC performance.

2.14.1 Radiated Emissions

Microcontroller radiated RF emissions are measured from 150 kHz to 1 GHz using the TEM/GTEM Cell method in accordance with the IEC 61967-2 and SAE J1752/3 standards. The measurement is performed with the microcontroller installed on a custom EMC evaluation board while running specialized EMC test software. The radiated emissions from the microcontroller are measured in a TEM cell in two package orientations (North and East). For more detailed information concerning the evaluation results, conditions and setup, please refer to the EMC Evaluation Report for this device.

3 Ordering Information

This section contains ordering information for MCF51AG128 devices.

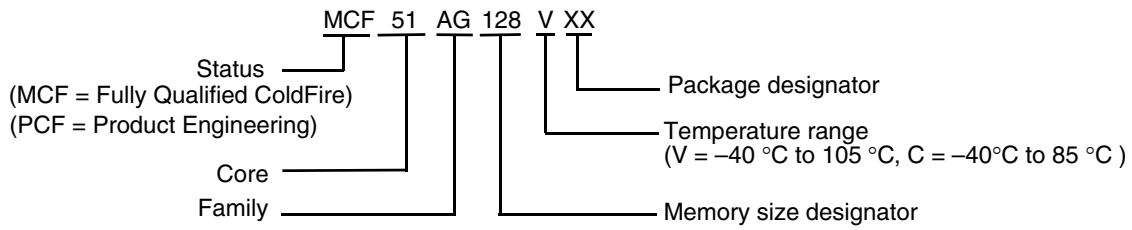

Table 20. Orderable Part Number Summary

Freescale Part Number	Description	Flash / SRAM (KB)	Package	Temperature
MCF51AG128VLK	MCF51AG128 ColdFire Microcontroller	128 / 16	80 LQFP	-40°C to 105°C
MCF51AG128VLH	MCF51AG128 ColdFire Microcontroller	128 / 16	64 LQFP	-40°C to 105°C
MCF51AG128VQH	MCF51AG128 ColdFire Microcontroller	128 / 16	64 QFP	-40°C to 105°C
MCF51AG128VLF	MCF51AG128 ColdFire Microcontroller	128 / 16	48 LQFP	-40°C to 105°C
MCF51AG96VLK	MCF51AG96 ColdFire Microcontroller	96 / 16	80 LQFP	-40°C to 105°C
MCF51AG96VLH	MCF51AG96 ColdFire Microcontroller	96 / 16	64 LQFP	-40°C to 105°C
MCF51AG96VQH	MCF51AG96 ColdFire Microcontroller	96 / 16	64 QFP	-40°C to 105°C
MCF51AG96VLF	MCF51AG96 ColdFire Microcontroller	96 / 16	48 LQFP	-40°C to 105°C

4 Package Information

Table 21. Package Descriptions

Pin Count	Package Type	Abbreviation	Designator	Case No.	Document No.
80	Low Quad Flat Package	LQFP	LK	917A	98ASS23237W
64	Low Quad Flat Package	LQFP	LH	840F	98ASS23234W
64	Quad Flat Package	QFP	QH	840B	98ASB42844B
48	Low Quad Flat Package	LQFP	LF	932	98ASH00962A

5 Mechanical Outline Drawings

5.1 80-pin LQFP Package

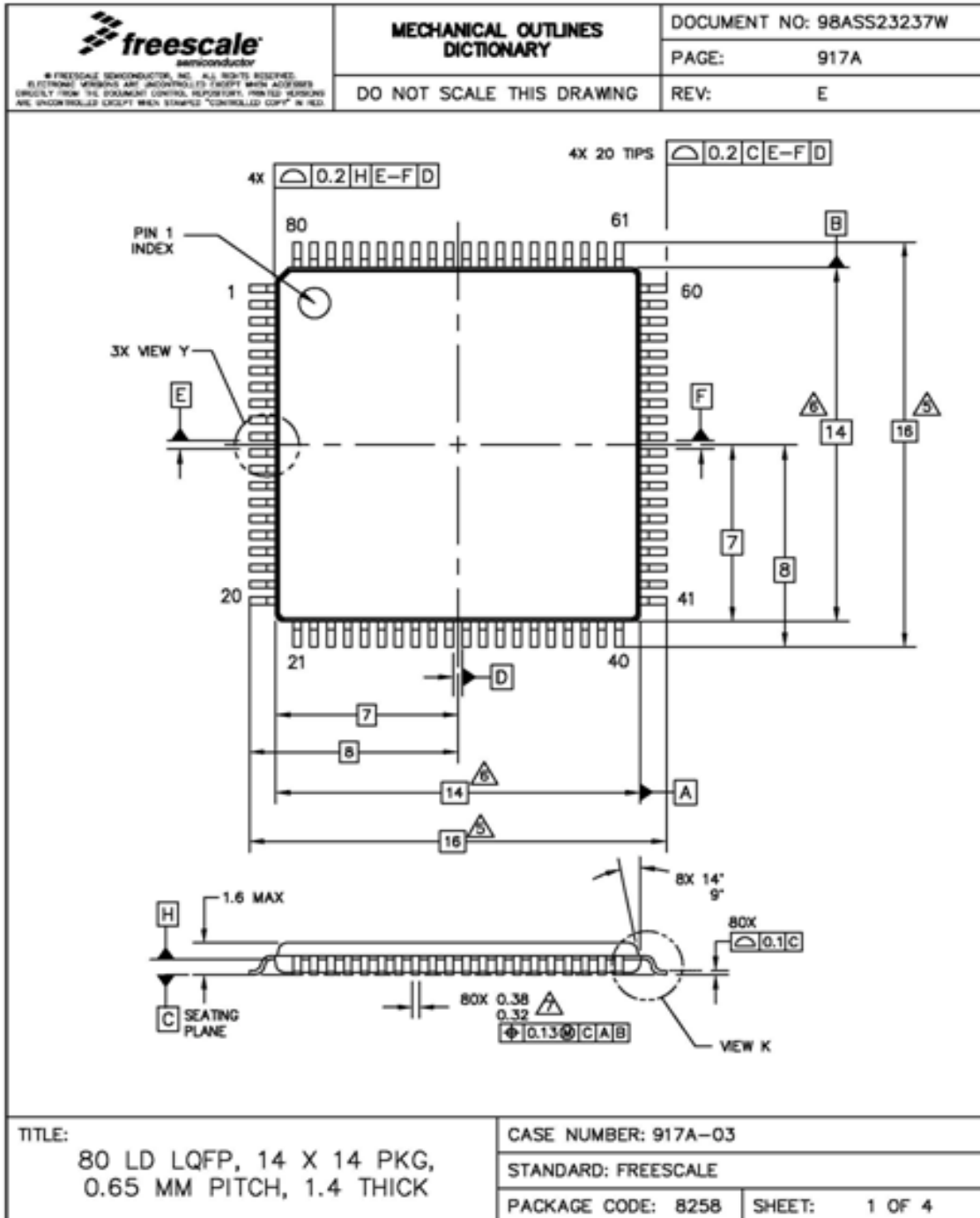

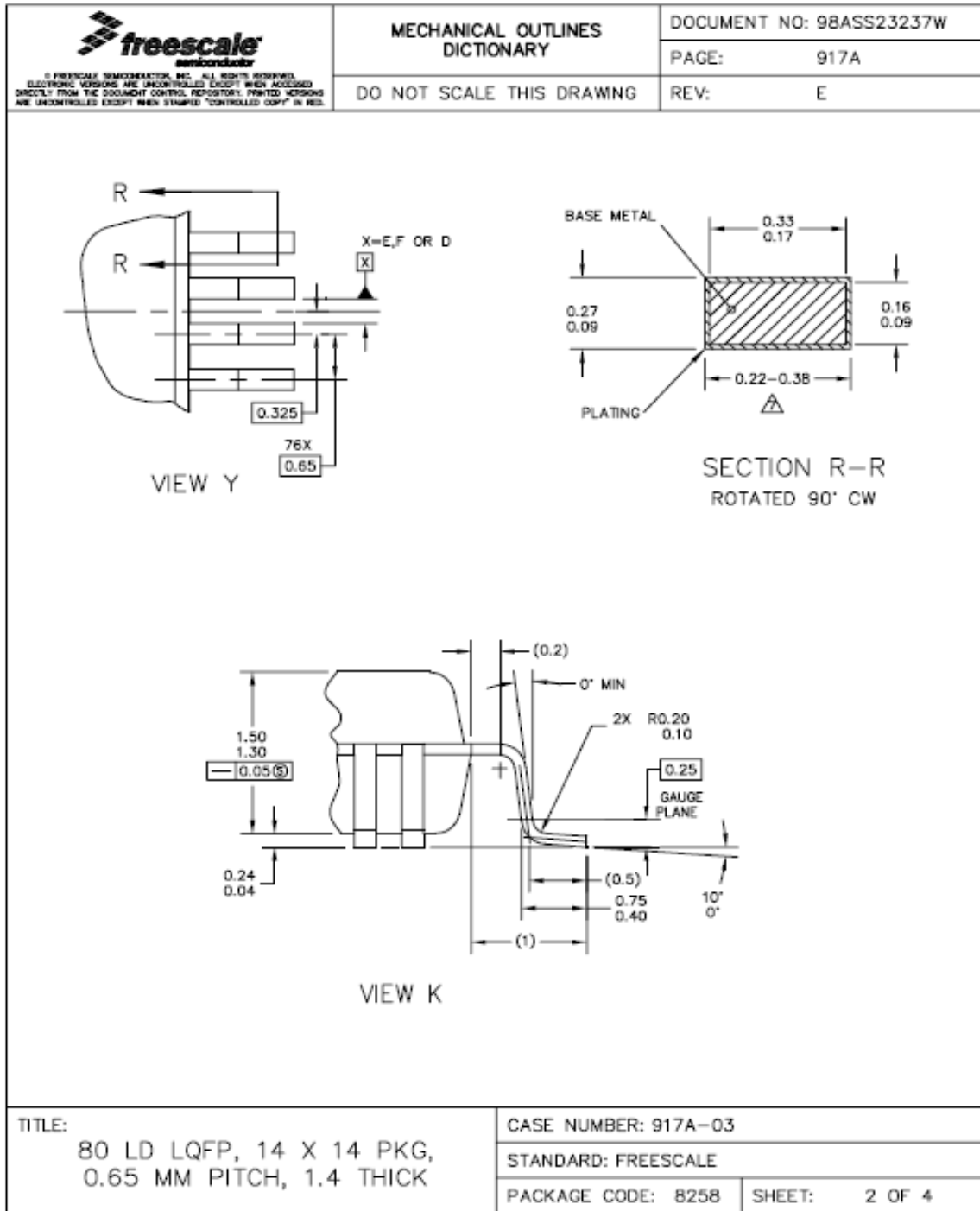

<p><small>© FREESCALE SEMICONDUCTOR, INC. ALL RIGHTS RESERVED. ELECTRONIC VERSIONS ARE UNCONTROLLED EXCEPT WHEN ACCESSED DIRECTLY FROM THE DOCUMENT CONTROL REPOSITORY. PRINTED VERSIONS ARE UNCONTROLLED EXCEPT WHEN STAMPED "CONTROLLED COPY" IN RED.</small></p>	MECHANICAL OUTLINES DICTIONARY	DOCUMENT NO: 98ASS23237W	
	DO NOT SCALE THIS DRAWING	PAGE:	917A
		REV:	E
<p>NOTES:</p> <ol style="list-style-type: none"> DIMENSIONING AND TOLERANCING PER ASME Y14.5M-1994. CONTROLLING DIMENSION : MILIMETER. DATUM PLANE H IS LOCATED AT THE BOTTOM OF LEAD AND IS COINCIDENT WITH THE LEAD WHERE THE LEAD EXITS THE PLASTIC BODY AT THE BOTTOM OF THE PARTING LINE. DATUM E, F AND D TO BE DETERMINED AT DATUM PLANE H. <p>5. DIMENSIONS TO BE DETERMINED AT SEATING PLANE C.</p> <p>6. DIMENSIONS DO NOT INCLUDE MOLD PROTRUSION. ALLOWABLE PROTRUSION IS 0.25 PER SIDE. DIMENSIONS DO INCLUDE MOLD MISMATCH AND ARE DETERMINED AT DATUM PLANE H.</p> <p>7. DIMENSION DOES NOT INCLUDE DAMBAR PROTRUSION. DAMBAR PROTRUSION SHALL NOT CAUSE THE LEAD WIDTH TO EXCEED 0.46. MINIMUM SPACE BETWEEN PROTRUSION AND ADJACENT LEAD OR PROTRUSION 0.07.</p>			
TITLE: 80 LD LQFP, 14 X 14 PKG, 0.65 MM PITCH, 1.4 THICK		CASE NUMBER: 917A-03	
		STANDARD: FREESCALE	
		PACKAGE CODE: 8258	SHEET: 3 OF 4

5.2 64-pin LQFP Package

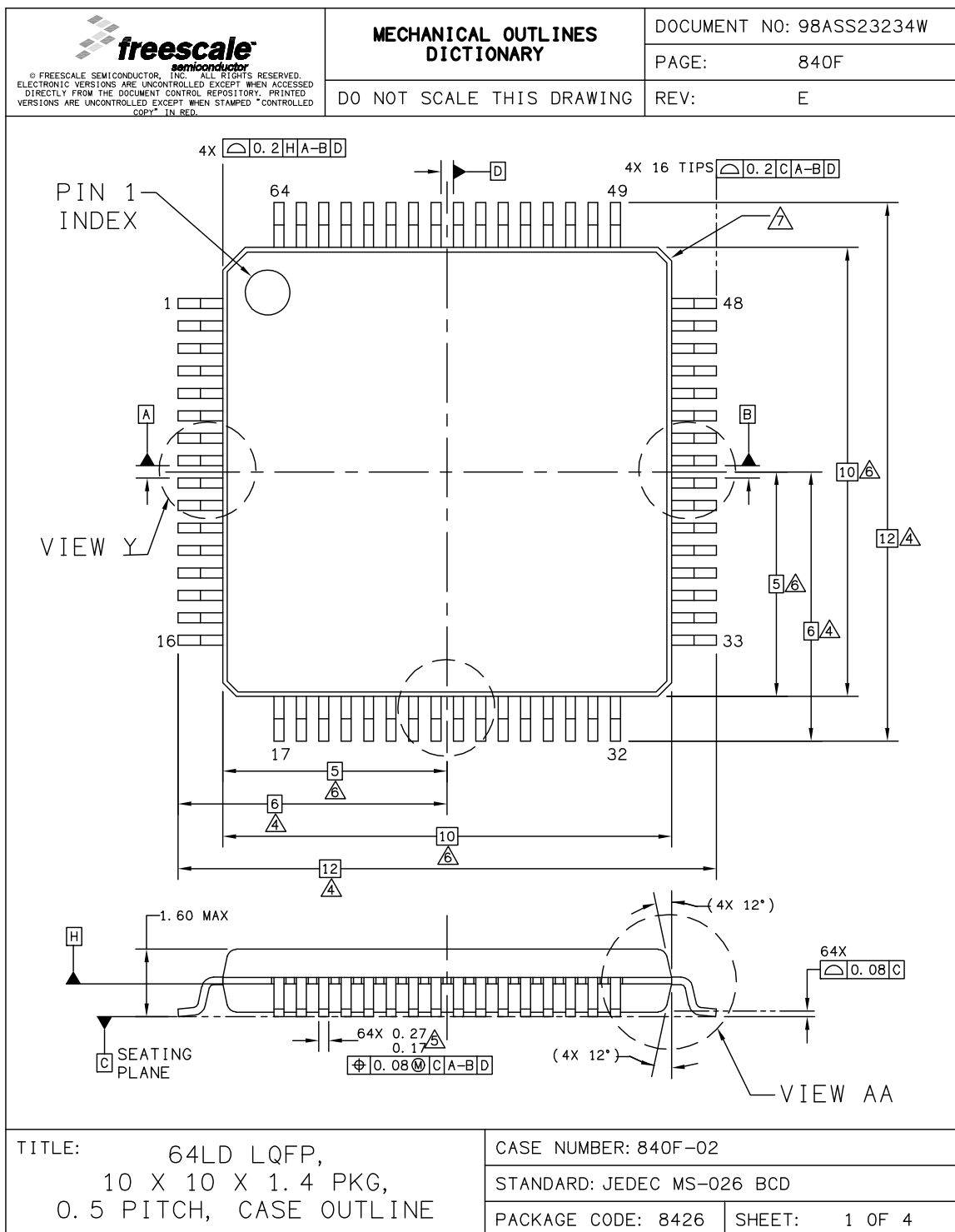

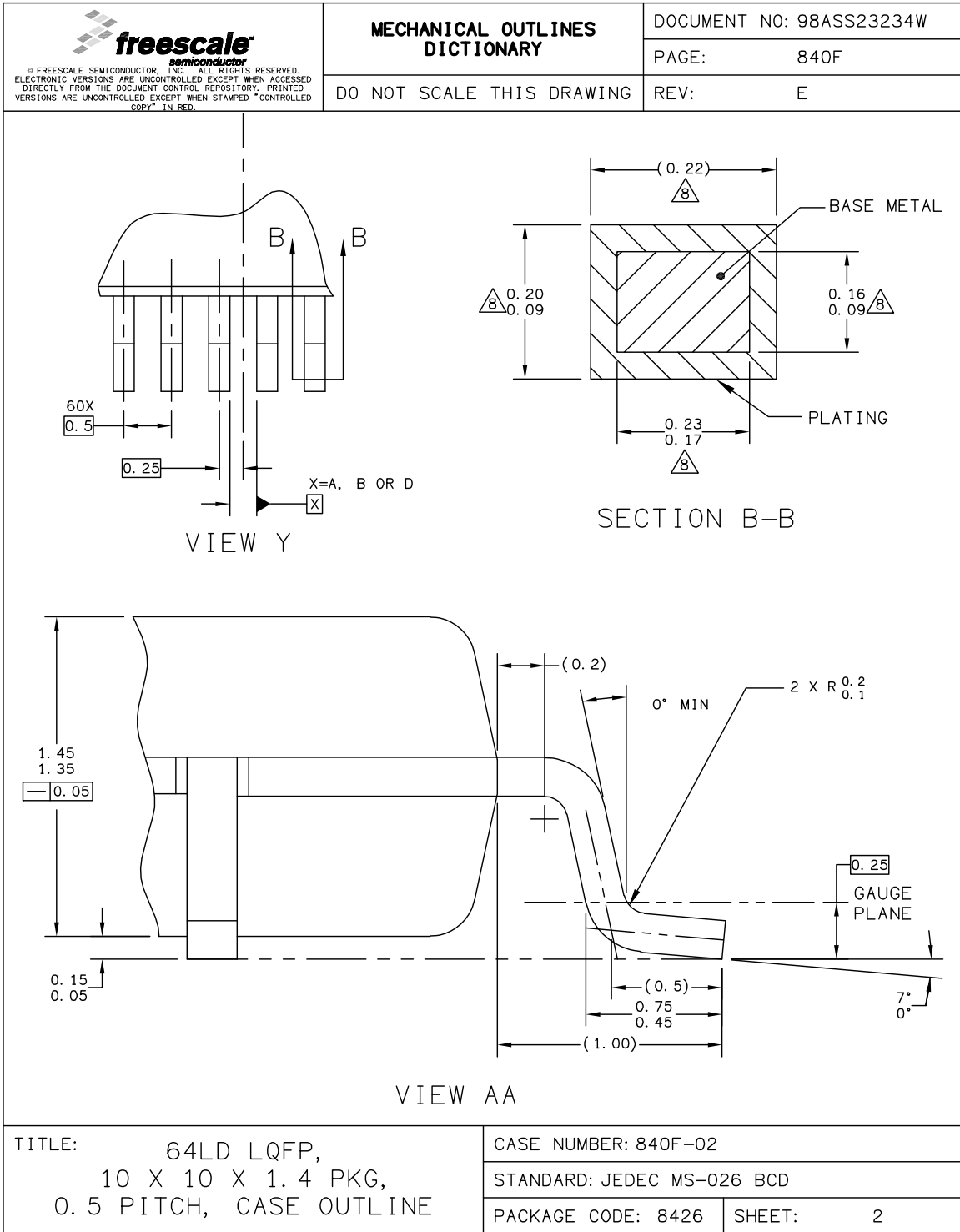

<p>© FREESCALE SEMICONDUCTOR, INC. ALL RIGHTS RESERVED. ELECTRONIC VERSIONS ARE UNCONTROLLED EXCEPT WHEN ACCESSED DIRECTLY FROM THE DOCUMENT CONTROL REPOSITORY. PRINTED VERSIONS ARE UNCONTROLLED EXCEPT WHEN STAMPED "CONTROLLED COPY" IN RED.</p>	<p>MECHANICAL OUTLINES DICTIONARY</p> <p>DO NOT SCALE THIS DRAWING</p>	DOCUMENT NO: 98ASS23234W	
		PAGE:	840F
		REV:	E
<p>NOTES:</p> <ol style="list-style-type: none"> 1. DIMENSIONS ARE IN MILLIMETERS. 2. DIMENSIONING AND TOLERANCING PER ASME Y14.5M-1994. 3. DATUMS A, B AND D TO BE DETERMINED AT DATUM PLANE H. 4. DIMENSIONS TO BE DETERMINED AT SEATING PLANE C. 5. THIS DIMENSION DOES NOT INCLUDE DAMBAR PROTRUSION. ALLOWABLE DAMBAR PROTRUSION SHALL NOT CAUSE THE LEAD WIDTH TO EXCEED THE UPPER LIMIT BY MORE THAN 0.08 mm AT MAXIMUM MATERIAL CONDITION. DAMBAR CANNOT BE LOCATED ON THE LOWER RADIUS OR THE FOOT. MINIMUM SPACE BETWEEN PROTRUSION AND ADJACENT LEAD SHALL NOT BE LESS THAN 0.07 mm. 6. THIS DIMENSION DOES NOT INCLUDE MOLD PROTRUSION. ALLOWABLE PROTRUSION IS 0.25 mm PER SIDE. THIS DIMENSION IS MAXIMUM PLASTIC BODY SIZE DIMENSION INCLUDING MOLD MISMATCH. 7. EXACT SHAPE OF EACH CORNER IS OPTIONAL. 8. THESE DIMENSIONS APPLY TO THE FLAT SECTION OF THE LEAD BETWEEN 0.1 mm AND 0.25 mm FROM THE LEAD TIP. 			
<p>TITLE: 64LD LQFP, 10 X 10 X 1.4 PKG, 0.5 PITCH, CASE OUTLINE</p>		CASE NUMBER: 840F-02	
		STANDARD: JEDEC MS-026 BCD	
		PACKAGE CODE: 8426	SHEET: 3

5.3 64-pin QFP Package

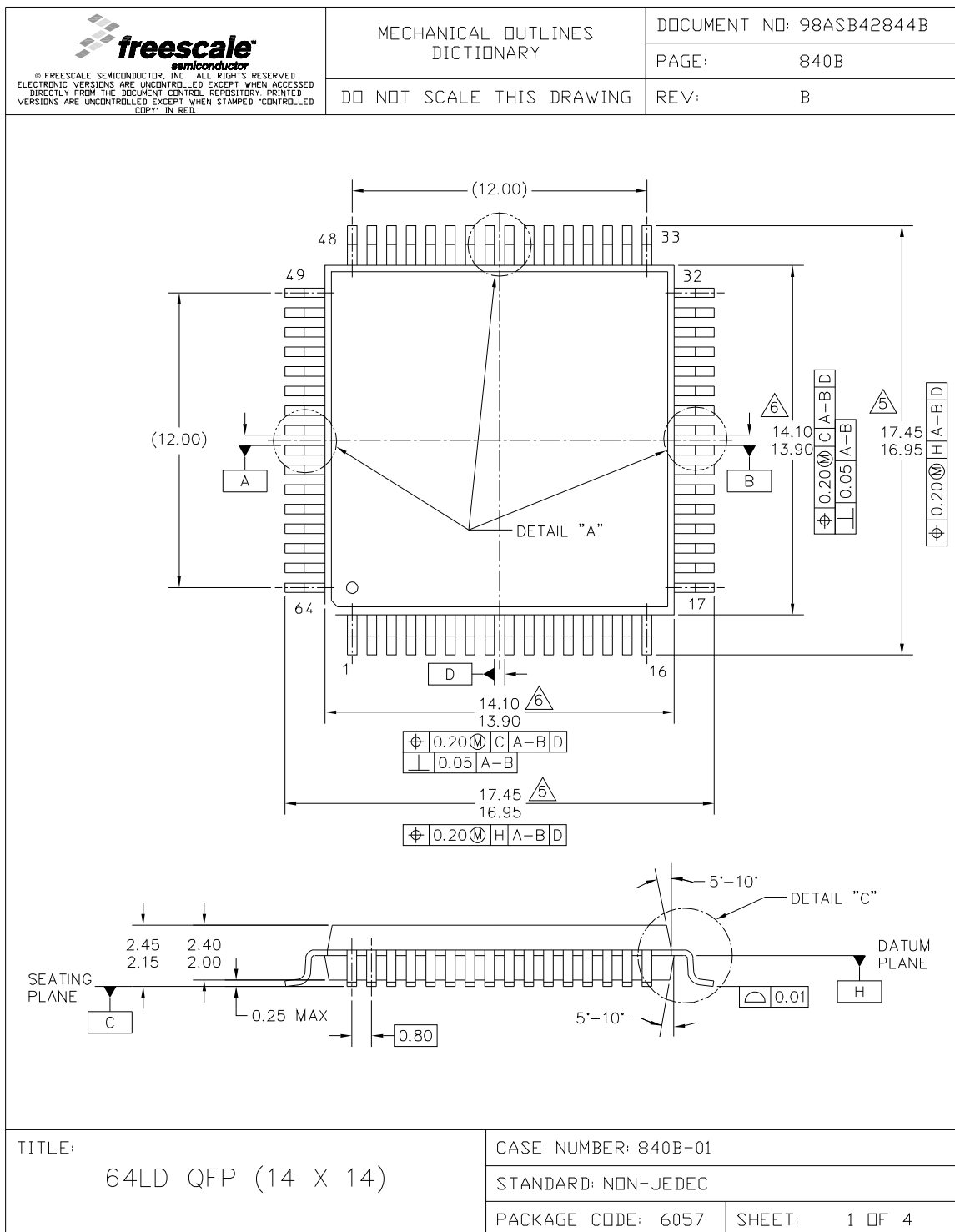

TITLE:
64LD QFP (14 X 14)

CASE NUMBER: 840B-01

STANDARD: NON-JEDEC

PACKAGE CODE: 6057

SHEET: 1 OF 4

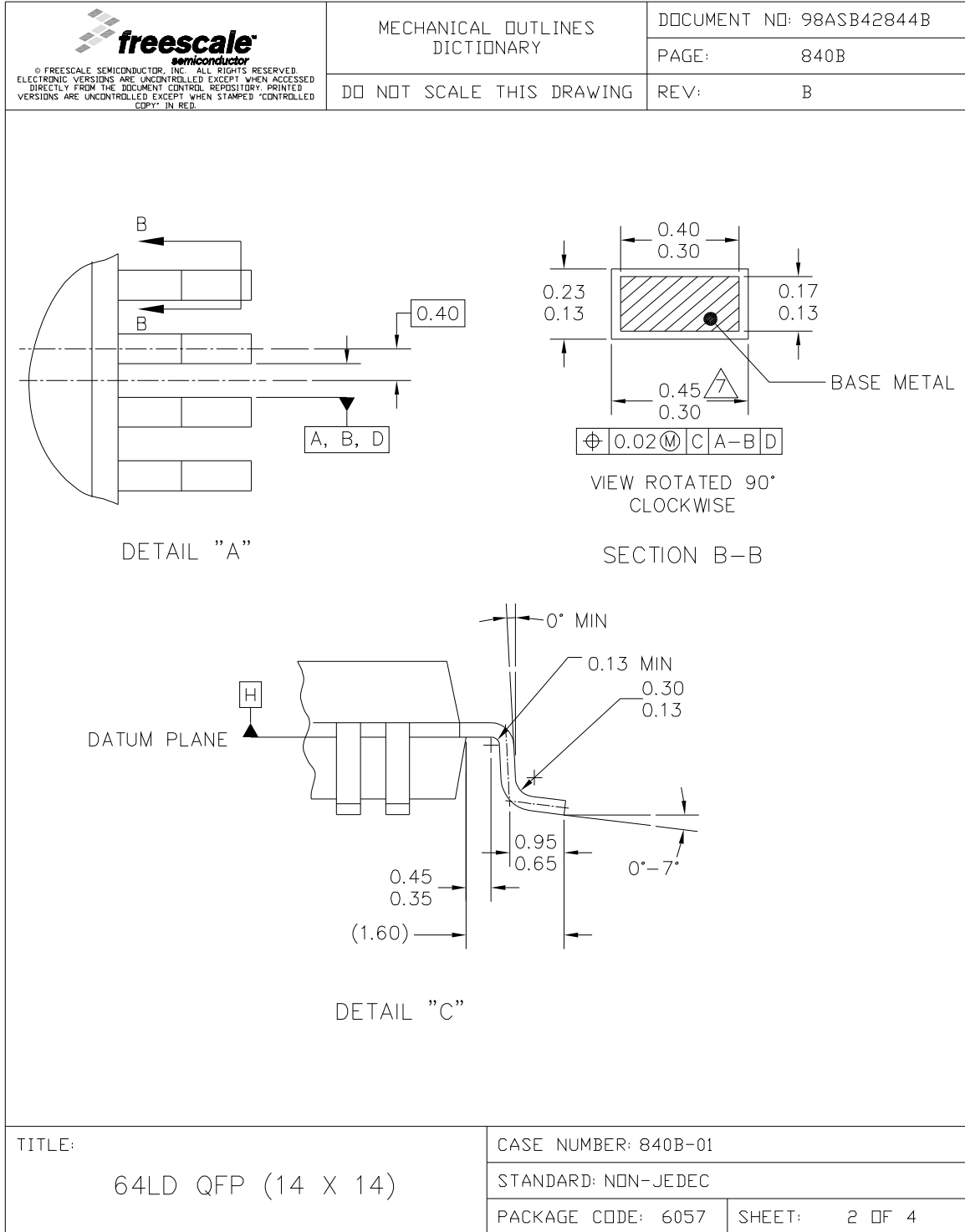

<p>© FREESCALE SEMICONDUCTOR, INC. ALL RIGHTS RESERVED. ELECTRONIC VERSIONS ARE UNCONTROLLED EXCEPT WHEN ACCESSED DIRECTLY FROM THE DOCUMENT CONTROL REPOSITORY. PRINTED VERSIONS ARE UNCONTROLLED EXCEPT WHEN STAMPED "CONTROLLED COPY" IN RED.</p>	MECHANICAL OUTLINES DICTIONARY		DOCUMENT NO: 98ASB42844B	
	DO NOT SCALE THIS DRAWING		PAGE:	840B
			REV:	B
<p>NOTES:</p> <ol style="list-style-type: none"> DIMENSIONING AND TOLERANCING PER ASME Y14.5M, 1994. CONTROLLING DIMENSION: MILLIMETER. DATUM PLANE -H- IS LOCATED AT BOTTOM OF LEAD AND IS COINCIDENT WITH THE LEAD WHERE THE LEAD EXITS THE PLASTIC BODY AT THE BOTTOM OF THE PARTING LINE. DATUMS A-B AND -D- TO BE DETERMINED AT DATUM PLANE -H-. <p> DIMENSIONS TO BE DETERMINED AT SEATING PLANE -C-.</p> <p> DIMENSIONS DO NOT INCLUDE MOLD PROTRUSION. ALLOWABLE PROTRUSION IS 0.25mm PER SIDE. DIMENSIONS DO INCLUDE MOLD MISMATCH AND ARE DETERMINED AT DATUM PLANE -H-.</p> <p> DIMENSION DOES NOT INCLUDE DAMBAR PROTRUSION. ALLOWABLE DAMBAR PROTRUSION SHALL BE 0.08mm TOTAL IN EXCESS OF THE DIMENSION AT MAXIMUM MATERIAL CONDITION. DAMBAR CANNOT BE LOCATED ON THE LOWER RADIUS OR THE FOOT.</p>				
TITLE:		CASE NUMBER: 840B-01		
64LD QFP (14 X 14)		STANDARD: NON-JEDEC		
		PACKAGE CODE: 6057	SHEET: 3 OF 4	

5.4 48-pin LQFP Package

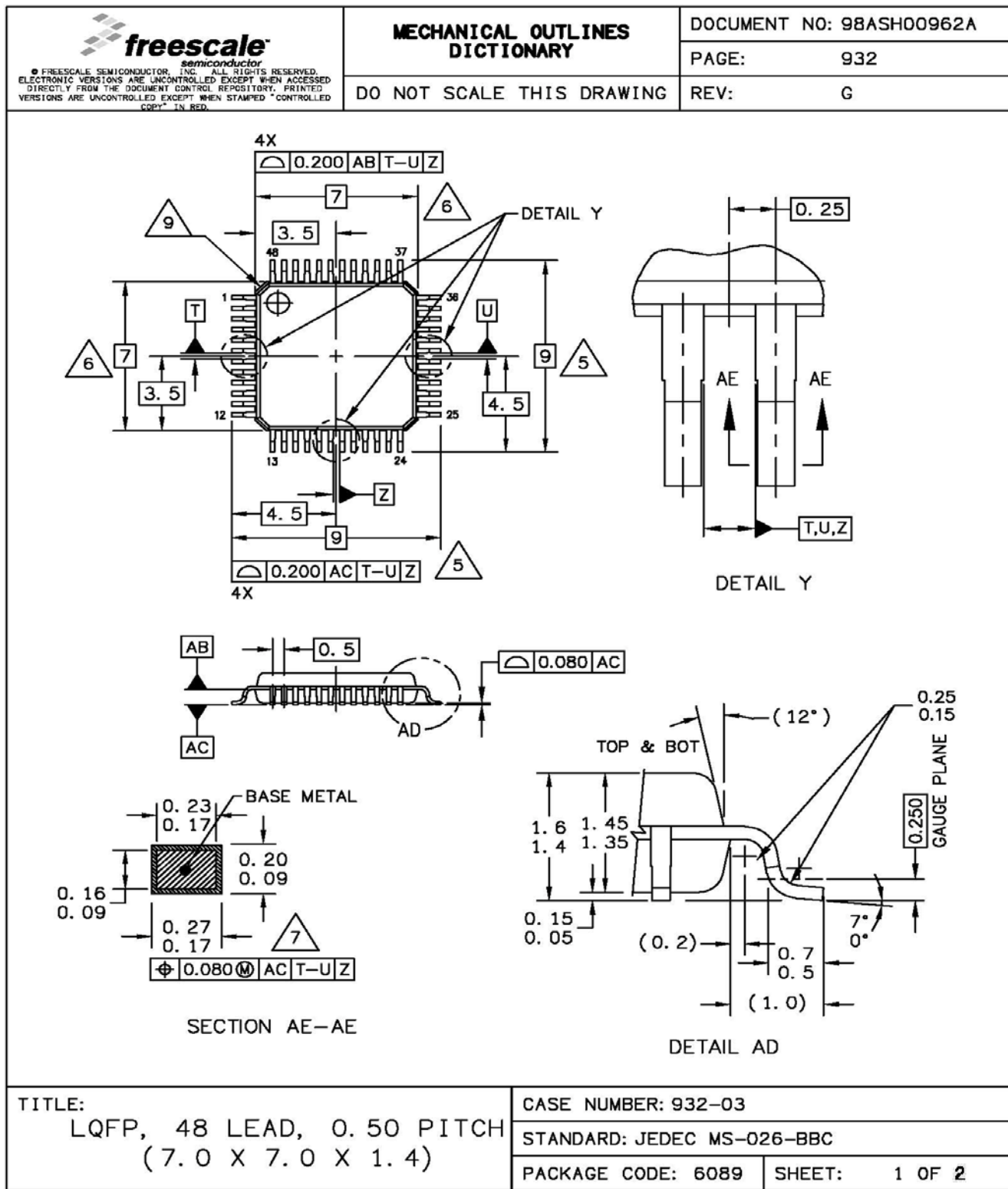

TITLE:
LQFP, 48 LEAD, 0.50 PITCH
(7.0 X 7.0 X 1.4)

CASE NUMBER: 932-03	
STANDARD: JEDEC MS-026-BBC	
PACKAGE CODE: 6089	SHEET: 1 OF 2

<p>freescale semiconductor</p> <small>© FREESCALE SEMICONDUCTOR, INC. ALL RIGHTS RESERVED. ELECTRONIC VERSIONS ARE UNCONTROLLED EXCEPT WHEN ACCESSED DIRECTLY FROM THE DOCUMENT CONTROL REPOSITORY. PRINTED VERSIONS ARE UNCONTROLLED EXCEPT WHEN STAMPED "CONTROLLED COPY" IN RED.</small>	MECHANICAL OUTLINES DICTIONARY	DOCUMENT NO: 98ASH00962A	
		DO NOT SCALE THIS DRAWING	PAGE: 932
			REV: G
<p>NOTES:</p> <ol style="list-style-type: none"> 1. DIMENSIONS AND TOLERANCING PER ASME Y14.5M-1994. 2. CONTROLLING DIMENSION: MILLIMETER. 3. DATUM PLANE AB IS LOCATED AT BOTTOM OF LEAD AND IS COINCIDENT WITH THE LEAD WHERE THE LEAD EXITS THE PLASTIC BODY AT THE BOTTOM OF THE PARTING LINE. 4. DATUMS T, U, AND Z TO BE DETERMINED AT DATUM PLANE AB. 5. DIMENSIONS TO BE DETERMINED AT SEATING PLANE AC. 6. DIMENSIONS DO NOT INCLUDE MOLD PROTRUSION. ALLOWABLE PROTRUSION IS 0.250 PER SIDE. DIMENSIONS DO INCLUDE MOLD MISMATCH AND ARE DETERMINED AT DATUM PLANE AB. 7. THIS DIMENSION DOES NOT INCLUDE DAMBAR PROTRUSION. DAMBAR PROTRUSION SHALL NOT CAUSE THE LEAD WIDTH TO EXCEED 0.350. 8. MINIMUM SOLDER PLATE THICKNESS SHALL BE 0.0076. 9. EXACT SHAPE OF EACH CORNER IS OPTIONAL. 			
TITLE: LQFP, 48 LEAD, 0.50 PITCH (7.0 X 7.0 X 1.4)		CASE NUMBER: 932-03	
		STANDARD: JEDEC MS-026-BBC	
		PACKAGE CODE: 6089	SHEET: 2 OF 2

6 Revision History

Table 22. Revision History

Rev. No.	Date	Description
1	11/2008	Initial Draft Release.
2	4/2009	Internal Release.
3	5/2009	Alpha Customer Release.
4	12/2009	<ul style="list-style-type: none"> • Added 48-pin LQFP information; • Updated Section 2.5/17 and 2.6/21. • Provided the supply current in Section 2.7/23, and setup delay in Section 2.8/23.
5	6/2010	<ul style="list-style-type: none"> • Updated Table 10. • Added Figure 9. • Corrected pin names of PTG6 and PTG5 in 48-pin LQFP. • Standardized Generation 2008 Watchdog to Watchdog. • In Table 9, updated Output high/low voltage — Low Drive (PTxDSn = 0) 3 V, I_{Load} value.

THIS PAGE INTENTIONALLY BLANK

How to Reach Us:**Home Page:**

www.freescale.com

Web Support:

<http://www.freescale.com/support>

USA/Europe or Locations Not Listed:

Freescale Semiconductor, Inc.
Technical Information Center, EL516
2100 East Elliot Road
Tempe, Arizona 85284
+1-800-521-6274 or +1-480-768-2130
www.freescale.com/support

Europe, Middle East, and Africa:

Freescale Halbleiter Deutschland GmbH
Technical Information Center
Schatzbogen 7
81829 Muenchen, Germany
+44 1296 380 456 (English)
+46 8 52200080 (English)
+49 89 92103 559 (German)
+33 1 69 35 48 48 (French)
www.freescale.com/support

Japan:

Freescale Semiconductor Japan Ltd.
Headquarters
ARCO Tower 15F
1-8-1, Shimo-Meguro, Meguro-ku,
Tokyo 153-0064
Japan
0120 191014 or +81 3 5437 9125
support.japan@freescale.com

Asia/Pacific:

Freescale Semiconductor China Ltd.
Exchange Building 23F
No. 118 Jianguo Road
Chaoyang District
Beijing 100022
China
+86 10 5879 8000
support.asia@freescale.com

For Literature Requests Only:

Freescale Semiconductor Literature Distribution Center
1-800-441-2447 or 303-675-2140
Fax: 303-675-2150
LDCForFreescaleSemiconductor@hibbertgroup.com

Information in this document is provided solely to enable system and software implementers to use Freescale Semiconductor products. There are no express or implied copyright licenses granted hereunder to design or fabricate any integrated circuits or integrated circuits based on the information in this document.

Freescale Semiconductor reserves the right to make changes without further notice to any products herein. Freescale Semiconductor makes no warranty, representation or guarantee regarding the suitability of its products for any particular purpose, nor does Freescale Semiconductor assume any liability arising out of the application or use of any product or circuit, and specifically disclaims any and all liability, including without limitation consequential or incidental damages. "Typical" parameters that may be provided in Freescale Semiconductor data sheets and/or specifications can and do vary in different applications and actual performance may vary over time. All operating parameters, including "Typicals", must be validated for each customer application by customer's technical experts. Freescale Semiconductor does not convey any license under its patent rights nor the rights of others. Freescale Semiconductor products are not designed, intended, or authorized for use as components in systems intended for surgical implant into the body, or other applications intended to support or sustain life, or for any other application in which the failure of the Freescale Semiconductor product could create a situation where personal injury or death may occur. Should Buyer purchase or use Freescale Semiconductor products for any such unintended or unauthorized application, Buyer shall indemnify and hold Freescale Semiconductor and its officers, employees, subsidiaries, affiliates, and distributors harmless against all claims, costs, damages, and expenses, and reasonable attorney fees arising out of, directly or indirectly, any claim of personal injury or death associated with such unintended or unauthorized use, even if such claim alleges that Freescale Semiconductor was negligent regarding the design or manufacture of the part.

RoHS-compliant and/or Pb-free versions of Freescale products have the functionality and electrical characteristics as their non-RoHS-compliant and/or non-Pb-free counterparts. For further information, see <http://www.freescale.com> or contact your Freescale sales representative.

For information on Freescale's Environmental Products program, go to <http://www.freescale.com/epp>.

Freescale™ and the Freescale logo are trademarks of Freescale Semiconductor, Inc. All other product or service names are the property of their respective owners.
© Freescale Semiconductor, Inc. 2010. All rights reserved.

Document Number: MCF51AG128

Rev. 5
6/2010

X-ON Electronics

Largest Supplier of Electrical and Electronic Components

Click to view similar products for [32-bit Microcontrollers - MCU category](#):

Click to view products by [NXP manufacturer](#):

Other Similar products are found below :

[MB91F575BHSPMC-GSE1](#) [MB91F594BSPMC-GSE1](#) [PIC32MX120F032B-50I/ML](#) [MB91F464AAPMC-GSE2](#) [MB91F577BHSPMC-GSE1](#)
[MB91F528USCPMC-GSE2](#) [MB91F248PFV-GE1](#) [MB91F594BPMC-GSE1](#) [MB91243PFV-GS-136E1](#) [MB91F577BHSPMC1-GSE1](#)
[PIC32MM0032GPL020-E/ML](#) [PIC32MM0016GPL028-E/SS](#) [PIC32MM0016GPL028-E/ML](#) [PIC32MM0032GPL028-E/ML](#)
[PIC32MM0032GPL028-E/M6](#) [SPC5604BF2VLL6](#) [MB91F526KSEPMC-GSE1](#) [TLE9872QTW40XUMA1](#) [FT902L-T](#) [R5F564MLCDFB#31](#)
[R5F564MLCDFC#31](#) [R5F523E5ADFL#30](#) [R5F524TAADFF#31](#) [MCF51AC256ACPUE](#) [PIC32MX150F128D-I/ML](#) [PIC32MX230F064D-](#)
[I/PT](#) [PIC32MM0064GPL028-I/ML](#) [PIC32MM0064GPL028-I/SP](#) [PIC32MM0064GPL028-I/SO](#) [PIC32MX120F032D-I/TL](#)
[PIC32MX130F064D-I/ML](#) [PIC32MZ2064DAB169-I/HF](#) [PIC32MZ2064DAB288-I/4J](#) [ATUC256L4U-AUT](#) [R5F56318CDBG#U0](#)
[PIC32MX150F128C-I/TL](#) [PIC32MX130F064C-ITL](#) [PIC32MX230F064D-IML](#) [PIC32MX154F128D-I/PT](#) [PIC32MX154F128B-V/SO](#)
[AT32UC3L0128-AUT](#) [PIC32MX254F128B-I/SO](#) [PIC32MX230F128H-I/MR](#) [PIC32MX150F128D-50I/TL](#) [PIC32MZ1064DAB288-I/4J](#)
[PIC32MZ1064DAB169-I/HF](#) [ATUC64D4-Z1UT](#) [AT32UC3A3128S-CTUT](#) [ATUC128L3U-Z3UT](#) [ATUC64L3U-Z3UT](#)