

## Quick Start Guide

# Multisensory Enablement Kit

## i.MX 8QuadMax MEK CPU Board

Based on i.MX 8QuadMax Application Processor



# GET TO KNOW THE MEK BASED ON i.MX 8QUADMAX APPLICATION PROCESSOR

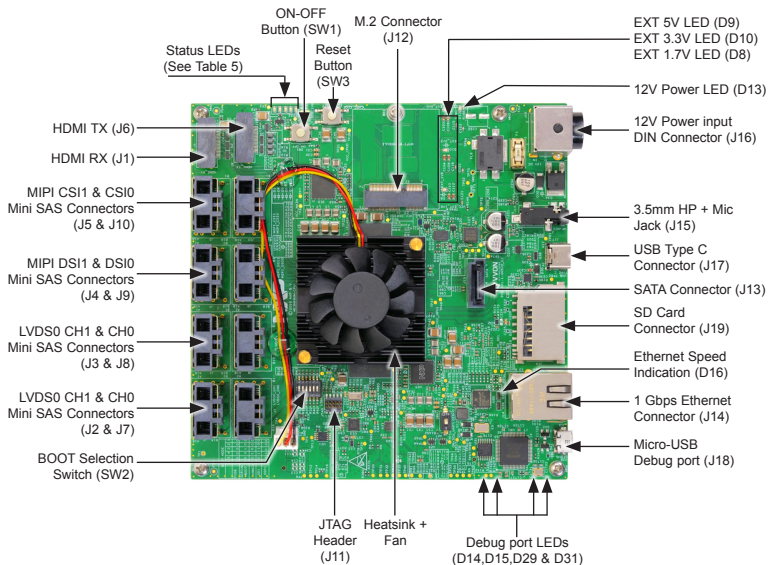
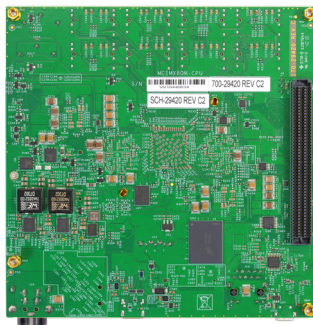

Figure 1: Main interfaces of i.MX 8QuadMax MEK CPU board



Board-to-Board Connector  
for Interface with Base Board  
Part Number: MCIMX8-8X-BB

Figure 2: Bottom View i.MX 8QuadMax MEK CPU board



Mini SAS Connector

HDMI Connector

Figure 3: LVDS to HDMI Adaptor Card  
Part Number: IMX-LVDS-HDMI

### ABOUT THE MULTISENSORY ENABLEMENT KIT BASED ON THE i.MX 8QUADMAX APPLICATION PROCESSOR.

The i.MX 8QuadMax Multisensory Enablement Kit (MEK) is an evaluation platform for the i.MX 8QuadMax Application Processor. Hardware design files, software tools and board support packages (BSPs) for Linux, Android, and FreeRTOS are available for customers to use as a reference for starting design of their products.

The i.MX 8QuadMax MEK consists of a CPU board and an optional Base board, MCIMX8-8X-BB (ordered separately).

Extended Audio features are supported by an Audio card (IMX- AUD-IO) which is included with the BaseBoard.

## FEATURES

The following features are available with the MEK CPU board based on the i.MX 8QuadMax application processor:

- i.MX 8QuadMax processor with 9 cores (4x Arm® Cortex®-A53, 2x Cortex-A72, 2x Cortex-M4F, 1x HIFI4 DSP)
- 2x 3 GB 32-bit LPDDR4 with 1.6 GHz clock
- eMMC 5.0, 32 GB
- 64 MB Octal SPI NOR flash
- SD card Connector
- USB Type-C connector
- 1Gbps Ethernet
- SATA Connector
- Micro-USB to serial Converter for debug
- 4x mini-SAS LVDS connectors
- 2x mini-SAS MIPI-DSI connectors
- 2x Camera MIPI-CSI through mini-SAS connector
- HDMI Transmitter-Compatible with HDMI 2.0, eDP 1.4 and DP 1.2
- HDMI Receiver-Compatible with HDMI 2.0
- Sensors including:
  - Accelerometer
  - Gyroscope
  - Pressure Sensor with Altimetry
  - Ambient light sensor
- LEDs for Power and Reset Indication
- M.2 Connector for WiFi/BT (PCIe, USB, UART, I<sup>2</sup>C and I<sup>2</sup>S)
- Audio codec (headphone + mic jack)
- JTAG 10-Pin Connector

### GETTING STARTED

This section describes how to use the MEK and the required accessories to develop applications using the kit.

#### 1 Unpacking the Kit

The MEK is shipped with the items listed in Table 1. Ensure the items are available in the i.MX 8QuadMax MEK.

ITEM	DESCRIPTION
CPU board	CPU board with i.MX 8QuadMax application processor, memory and PMIC
Power supply	Power supply , 12V DC, 11.5A, Level VI , With DIN 4 Pin Output Type
AC Power cord	IEC cable assembly with locking system for IEC C14 inlet, US version, 1.83M
Worldwide Adapter	Hardware accessory , universal power adapter
LVDS-to-HDMI Adapter Card	PWA, IMX-LVDS-HDMI
Mini SAS cable	Cable assembly , IPASS(Mini-SAS), internal cable, 36 CKT 4X W/ Sidebands
JTAG- GEN2 Adapter Card	10-to-20 pin JTAG adapter
10-wire ribbon cable	Cable, Ribbon IDC, 1.27MM, 4", 10POS for JTAG adapter
USB Type-C cable	Cable -Assembly , USB 3.0 Type-A Female, USB Type-C Male, Shielded, 200mm
SD Card with BSP image	Module, SD Card, 16GB, Class -10
Micro USB Cable	USB Cable, USB A Male to Micro B , for interface to debug port
QSG	Quick Start Guide

Table 1: Contents of the i.MX 8QuadMax Multisensory Enablement Kit

## 2 Optional Accessories

Table 2 lists additional equipment not included with the i.MX 8QuadMax MEK.

ITEM	DESCRIPTION
HDMI Display	HDMI Display would be needed to connect to the LVDS to HDMI Adapter card

Table 2: Equipment provided by customer

### SETTING UP THE SYSTEM

#### 1 SD Card

Insert the MicroSD card into socket J19 on the MEK CPU Board.

#### 2 Connect USB Debug Cable

Connect the micro-B end of a USB cable into debug port, J18. Connect the other end of the cable to a PC acting as a host terminal.

Open the terminal window (i.e., Hyper Terminal or Tera Term) and apply the following configuration.

- Baud rate: 115200
- Data bits: 8
- Stop bit: 1
- Parity: None
- Flow control: None

#### 3 Connect the Headphone (Optional)

Connect the Headphone to the Audio Jack J15 (close to USB type C Connector)

#### 4 Connect Ethernet Cable (Optional)

Connect an Ethernet cable to the Ethernet Jack J14 (close to the Debug port).

#### 5 Connect USB type-C Cable (Optional)

Connect the Type C Male connector of the supplied USB Type-C male to Type- A female cable to the Type-C connector J17 (Close to the SD slot).



## 6 LVDS Adapter Card and Display (optional)

Connect the LVDS-to-HDMI daughter card to J2/J3/J7/J8 with the Mini SAS cable supplied in the package.

## 7 Wi-Fi / Bluetooth Module (Optional)

Connect the M.2 form factor Wi-Fi-Bluetooth module with E-key to the M.2 Connector J12. (Order from Murata)

## 8 Connect Power Supply

Connect the plug of the 12V power supply to the DIN connector J16. When power is connected to the MEK, it will automatically begin the boot sequence.

**CAUTION: To avoid damage, do not hot plug the daughter cards while the CPU card power is ON.**

### BOOT PROCESS FOR LINUX IMAGE

#### Boot Process

- Switch SW2 to OFF, OFF, ON, ON, OFF, OFF (from 1-6 bit) to boot from the SD card, as shown in Figure 4.
- Power on the MEK board.
- During the boot process, there will be console prints on the terminal window of the PC (if connected).
- To work from the terminal window on the host PC, press 'Enter' at the terminal window to get the command prompt. Account name: root, password none.

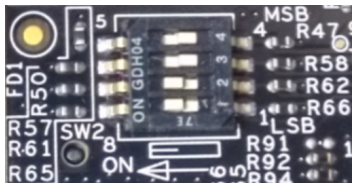

Figure 4: BOOT MODE switch

## DIP SWITCH CONFIGURATION

Table 3 shows the switch (SW2) configuration of boot mode for i.MX 8QuadMax MEK.

POS-6	POS-5	POS-4	POS-3	POS-2	POS-1	BOOT DEVICE
0	0	0	0	0	0	<b>BOOT From Fuse</b>
0	0	0	1	0	0	Serial Download
0	0	1	0	0	0	EMMC0
0	0	1	1	0	0	SD1
0	1	1	0	0	0	Octal SPI

Table 3: i.MX 8QuadMax MEK CPU DIP switch configuration

### BUTTON FUNCTIONS

Table 4 shows the functions of the push buttons and switches on the board.

ITEM	DESCRIPTION
SW1	MEK ON/OFF button <ul style="list-style-type: none"><li>• Press and hold f or 0.5 sec to turn ON, press and hold f or 5 sec to turn OFF.</li></ul>
SW2	MEK BOOT selection switch <ul style="list-style-type: none"><li>• Used f or boot conf igation according to SCU boot mode.</li></ul>
SW3	MEK RESET button <ul style="list-style-type: none"><li>• Pressing of the button will reset the sy stem and begin a boot sequence</li></ul>

Table 4: MEK board button operations

## LED STATUS

Table 5 shows the status of LEDs on the board

ITEM	DESCRIPTION
D5	Processor RESET status • ON : i.MX 8QM is in Active State , OFF : i.MX 8QM is in Reset State
D16	Ethernet speed Indication • ON : 1 Gbps , OFF : 10/100 Mbps
D4	PMIC Standby • ON : PMIC is in Standby mode , OFF : PMIC is in operational mode
D3	User Debug LED, controlled by SCU GPIO • ON : GPIO high , OFF : GPIO low
D13	12V Supply ON
D8	EXT_1V8 Supply ON
D10	EXT_3V3 Supply ON
D9	EXT_5V0 Supply ON
D6	According to M.2 module behavior
D7	According to M.2 module behavior
D31	UART Data RX (Pulses when Transmitting Data via USB)
D29	UART Data TX (Pulses when Receiving Data via USB)
D15	M40 UART0 Data RX (Pulses when Transmitting Data via USB)
D14	M40 UART0 Data TX (Pulses when Transmitting Data via USB)

Table 5: i.MX 8QM MEK CPU – LED Status

## SUPPORT

Visit [www.nxp.com/support](http://www.nxp.com/support) for a list of phone numbers within your region.

## WARRANTY

Visit [www.nxp.com/warranty](http://www.nxp.com/warranty) for complete warranty information.

## HOME PAGE

Visit [www.nxp.com/imx8x](http://www.nxp.com/imx8x) for more information.



## Get Started

Download installation software and documentation under **"Jump Start Your Design"** at [www.nxp.com/imx8QXPMEK](http://www.nxp.com/imx8QXPMEK).

[www.nxp.com](http://www.nxp.com)

NXP and the NXP logo are trademarks of NXP B.V. All other product or service names are the property of their respective owners. Arm and Cortex are registered trademarks of Arm Limited (or its subsidiaries) in the EU and/or elsewhere. All rights reserved. © 2019 NXP B.V.

Doc Number: IMX8QUADMAXQSG REV 3  
Agile Number: 926-29420 REV C

## X-ON Electronics

Largest Supplier of Electrical and Electronic Components

*Click to view similar products for [Development Boards & Kits - ARM category](#):*

*Click to view products by [NXP manufacturer](#):*

Other Similar products are found below :

[SAFETI-HSK-RM48](#) [PICOHOBBITFL](#) [CC-ACC-MMK-2443](#) [TWR-MC-FRDMKE02Z](#) [EVALSPEAR320CPU](#) [EVB-SCMIMX6SX](#)  
[MAX32600-KIT#](#) [TMDX570LS04HDK](#) [TXSD-SV70](#) [OM13080UL](#) [EVAL-ADUC7120QSPZ](#) [OM13082UL](#) [TXSD-SV71](#)  
[YGRPEACHNORMAL](#) [OM13076UL](#) [PICODWARFFL](#) [YR8A77450HA02BG](#) [3580](#) [32F3348DISCOVERY](#) [ATTINY1607](#) [CURIOSITY](#)  
[NANO](#) [PIC16F15376](#) [CURIOSITY NANO BOARD](#) [PIC18F47Q10](#) [CURIOSITY NANO](#) [VISIONSTK-6ULL V.2.0](#) [80-001428](#) [DEV-17717](#)  
[EAK00360](#) [YR0K77210B000BE](#) [RTK7EKA2L1S00001BE](#) [MAX32651-EVKIT#](#) [SLN-VIZN-IOT](#) [LV18F V6 DEVELOPMENT SYSTEM](#)  
[READY FOR AVR BOARD](#) [READY FOR PIC BOARD](#) [READY FOR PIC \(DIP28\)](#) [EVB-VF522R3](#) [AVRPLC16 V6 PLC SYSTEM](#)  
[MIKROLAB FOR AVR XL](#) [MIKROLAB FOR PIC L](#) [MINI-AT BOARD - 5V](#) [MINI-M4 FOR STELLARIS](#) [MOD-09.Z](#) [BUGGY +](#)  
[CLICKER 2 FOR PIC32MX + BLUETOOT](#) [1410](#) [LETS MAKE PROJECT PROGRAM. RELAY PIC](#) [LETS MAKE - VOICE](#)  
[CONTROLLED LIGHTS](#) [LPC-H2294](#) [DSPIC-READY2 BOARD](#) [DSPIC-READY3 BOARD](#) [MIKROBOARD FOR ARM 64-PIN](#)  
[MIKROLAB FOR AVR](#)