

EFFICIENT ELECTRIC MOTOR CONTROL WITH MCSPTR2A5775E



Expanding on the highly integrated MPC5775E microcontroller, the MCSPTR2A5775E motor control kit enables complex electric motor drive in the most efficient way for application targeting up to ISO 26262 ASIL D

The MCSPTR2A5775E motor control kit uses an enhanced time processing unit (eTPU) to offload the CPU and manage the PWM, the software resolver digital converter (RDC) and the FOC motor control algorithm as well, if needed.

The eTPU architecture provides the flexibility for customers by enabling a single-chip solution that can run sophisticated motor control systems without the need for a separate hardware resolver-to-digital converter. The eTPU can be used in three different configurations for maximum effectiveness.

MCSPTR2A5775E MOTOR CONTROL KIT FEATURES

- MPC5775E-EVB controller board with two eTPUs for PWM, resolver and FOC management
- MPC5775E EVB: MPC5775E evaluation board with Ethernet, LIN and CAN connectivity support, JTAG and OpenSDA programming/debugging
- 3-phase PMSM/BLDC low-voltage power stage based on the MC33937A pre-driver integrated circuit
- 3-phase PMSM motor with resolver, 25 V per phase, 3000 RPM, 0.51 Nm, 160 W, 7.6 A
- +24 VDC power supply
- Current sensing via shunt resistor

MCSPTR2A5775E TARGET APPLICATIONS:

- PMSM, BLDC motor control
- FOC
- Power inverter
- Powertrain motor control

SOFTWARE AND TOOLS

The MCSPTR2A5775E motor control kit is supported by S32 Design Studio, FreeMASTER and MCAT and comes pre-compiled with FOC motor control FOC firmware. MCSPTR2A5775E is also supported by the Model-Based Design Toolbox and its community at www.nxp.com/MBDT.

- S32DS
- Motor control firmware
- Freemaster GUI and Motor Control Application Tuning (MCAT)
- eTPU Function Selector
- Math and Motor Control Libraries
- MATLAB® Simulink® compatibility
- Detailed 3-Phase PMSM Motor Control Application Note with Software and Featured MCAT Tool
- Quick Start Guide

MCSPTR2A5775E ENABLEMENT NXP SOLUTION INCLUDES:

- Detailed 3-Phase PMSM Motor Control Application Note with Software and Featured MCAT Tool
- Quick Start Guide
- eTPU library usage in an application note

MCSPTR2A5775E BLOCK DIAGRAM

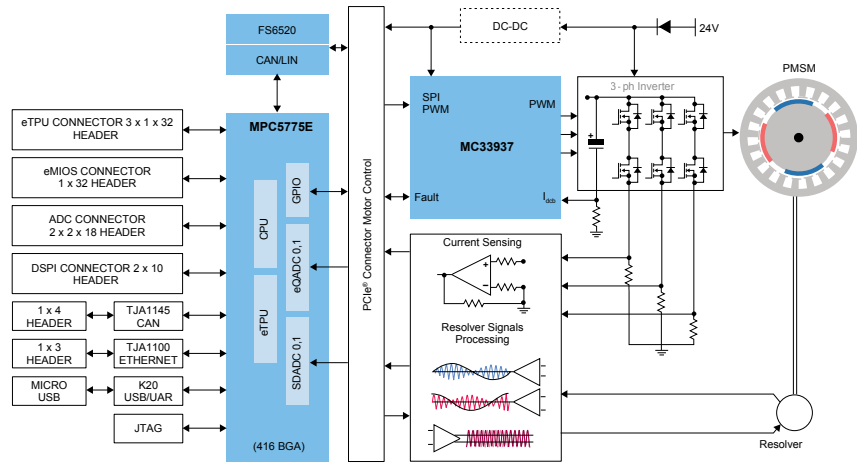

MCSPTR2A5775E FOC CONTROL LOOP

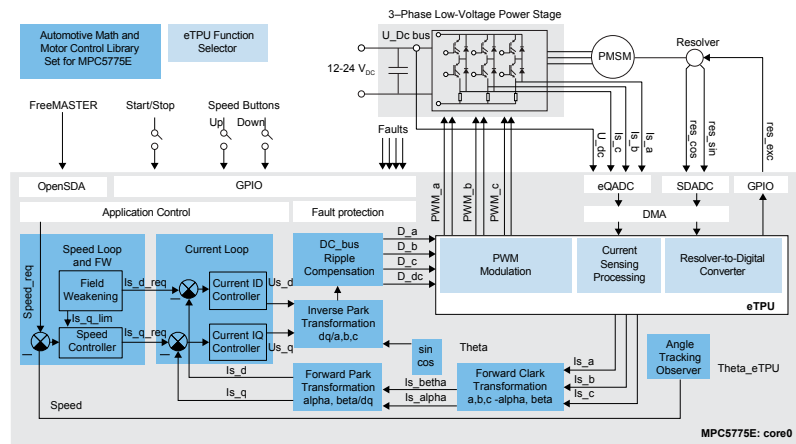

X-ON Electronics

Largest Supplier of Electrical and Electronic Components

Click to view similar products for [Power Management IC Development Tools](#) category:

Click to view products by [NXP](#) manufacturer:

Other Similar products are found below :

[EVAL-ADM1168LQEBZ](#) [EVB-EP5348UI](#) [MIC23451-AAAYFL EV](#) [MIC5281YMME EV](#) [DA9063-EVAL](#) [ADP122-3.3-EVALZ](#) [ADP130-0.8-EVALZ](#) [ADP130-1.2-EVALZ](#) [ADP130-1.5-EVALZ](#) [ADP130-1.8-EVALZ](#) [ADP1712-3.3-EVALZ](#) [ADP1714-3.3-EVALZ](#) [ADP1715-3.3-EVALZ](#) [ADP1716-2.5-EVALZ](#) [ADP1740-1.5-EVALZ](#) [ADP1752-1.5-EVALZ](#) [ADP1828LC-EVALZ](#) [ADP1870-0.3-EVALZ](#) [ADP1871-0.6-EVALZ](#) [ADP1873-0.6-EVALZ](#) [ADP1874-0.3-EVALZ](#) [ADP1882-1.0-EVALZ](#) [ADP199CB-EVALZ](#) [ADP2102-1.25-EVALZ](#) [ADP2102-1.875EVALZ](#) [ADP2102-1.8-EVALZ](#) [ADP2102-2-EVALZ](#) [ADP2102-3-EVALZ](#) [ADP2102-4-EVALZ](#) [ADP2106-1.8-EVALZ](#) [ADP2147CB-110EVALZ](#) [AS3606-DB](#) [BQ24010EVM](#) [BQ24075TEVM](#) [BQ24155EVM](#) [BQ24157EVM-697](#) [BQ24160EVM-742](#) [BQ24296MEVM-655](#) [BQ25010EVM](#) [BQ3055EVM](#) [NCV891330PD50GEVB](#) [ISLUSBI2CKIT1Z](#) [LM2744EVAL](#) [LM2854EVAL](#) [LM3658SD-AEV/NOPB](#) [LM3658SDEV/NOPB](#) [LM3691TL-1.8EV/NOPB](#) [LM4510SDEV/NOPB](#) [LM5033SD-EVAL](#) [LP38512TS-1.8EV](#)