

MIMXRT1020 EVK Board Hardware User's Guide

1. Introduction

This Hardware User's Guide for the MIMXRT1020 Evaluation Kit (EVK) is based on the NXP Semiconductor i.MX RT1020 Processor. This board is fully supported by NXP Semiconductor. The guide includes system setup and debugging, and provides detailed information on overall design and usage of the EVK board from a hardware systems perspective.

1.1. Board overview

This EVK board is a platform designed to showcase the most commonly used features of the i.MX RT1020 Processor in a small, low cost package. The MIMXRT1020 EVK board is an entry level development board, which gives the developer the option of becoming familiar with the processor before investing a large amount of resources in more specific designs.

Contents

1.	Introduction	1
1.1.	Board overview	1
1.2.	MIMXRT1020 EVK contents	2
1.3.	MIMXRT1020 EVK Board revision history	3
2.	Specifications	3
2.1.	i.MX RT1020 processor	5
2.2.	Boot Mode configurations.....	5
2.3.	Power tree	6
2.4.	SDRAM memory	9
2.5.	SD Card slot.....	9
2.6.	QSPI flash	9
2.7.	Ethernet connector	9
2.8.	USB PHY connector	10
2.9.	Audio input / output connector.....	10
2.10.	OpenSDA circuit (DAP-Link).....	10
2.11.	JTAG connector	10
2.12.	Arduino expansion port.....	11
2.13.	User interface LED indicator	13
3.	PCB information	13
4.	EVK design files	13
5.	Contents of the Evaluation Kit	14
6.	Revision history.....	14



Features of the MIMXRT1020 EVK board are shown in [Table 1](#)

Table 1. Board features

Processor	NXP Processor	MIMXRT1021
DRAM Memory	SDRAM 256 Mb, 166MHz	MT48LC16M16A2P
DCDC	MPS	MP2144GJ
LDO	UNION	UM1750S-00
Mass Storage	TF Card Slot	
	64 Mbit Quad SPI Flash	
Ethernet	10/100 Mbit/s Ethernet Connector. PHY Chip: KSZ8081RNB	
USB	USB 2.0 OTG Connector	
Audio Connector	3.5 mm Audio Stereo Headphone Jack	
	Board-Mounted Microphone	
	Left & Right Speaker Out Connectors	
Power Connector	5V DC-Jack	
Debug Connector	JTAG 20-pin Connector (SWD by default)	
	OpenSDA with DAP-Link	
Sensor	FXOS8700CQ: 6-Axis Ecompass (3-Axis Mag, 3-Axis Accel)	
CAN	CAN Bus Connector	
User Interface Button	ON/OFF, POR Reset, POWER Reset, USER Button	
Led Indicator	Power Status, Reset, OpenSDA, USER LED	
Expansion Port	Arduino Interface	
PCB	3.543-inch x 5.5118-inch (9cm x 14cm), 2-layer board	

1.2. MIMXRT1020 EVK contents

The MIMXRT1020 EVK contains the following items:

- MIMXRT1020 EVK Board
- USB Cable (Micro B)

1.3. MIMXRT1020 EVK Board revision history

- Rev A: Prototype.

2. Specifications

This chapter provides detailed information about the electrical design and practical considerations of the EVK Board, and is organized to discuss each block in the following block diagram of the EVK board. (*Figure 1*)

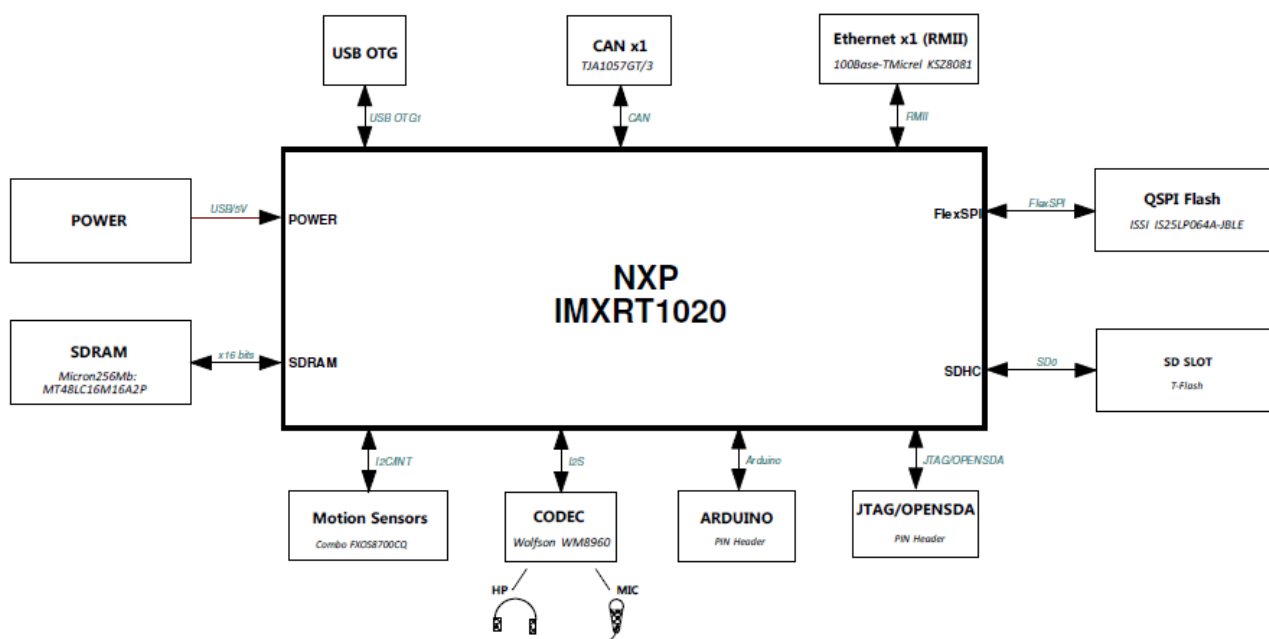

Figure 1. Block diagram

The overview of the MIMXRT1020 EVK Board is shown in *Figure 1* & *Figure 2*.

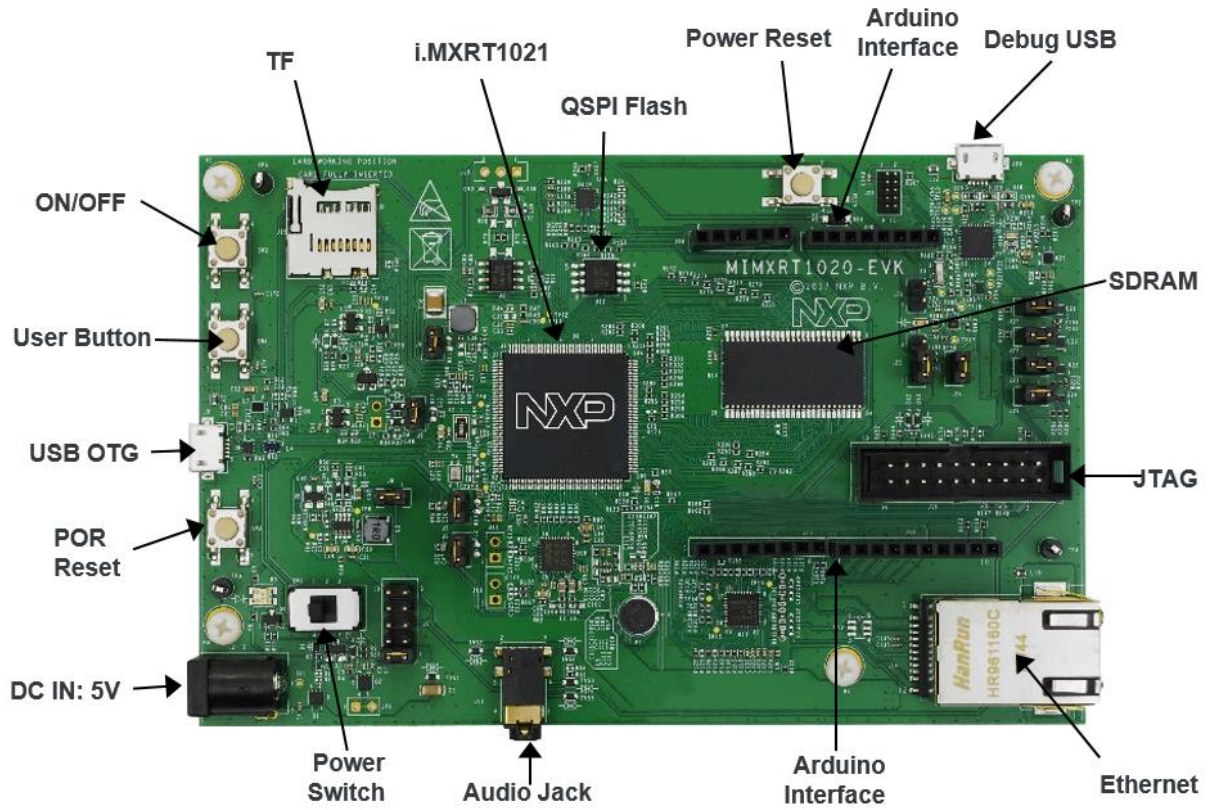

Figure 2. Overview of the MIMXRT1020 EVK Board (Front side)

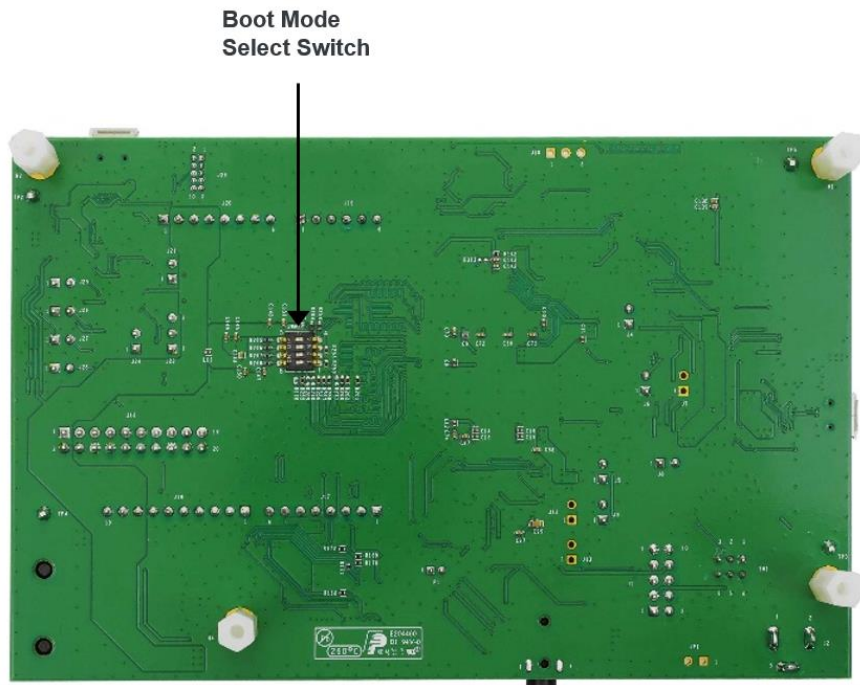

Figure 3. Overview of the MIMXRT1020 EVK Board (Back side)

2.1. i.MX RT1020 processor

The i.MX RT1020 is a new processor family featuring NXP's advanced implementation of the Arm® Cortex®-M7 Core. It provides high CPU performance and best real-time response. The i.MX RT1020 provides various memory interfaces, including SDRAM, Raw NAND FLASH, NOR FLASH, SD/eMMC, Quad SPI, HyperBus and a wide range of other interfaces for connecting peripherals, such as WLAN, Bluetooth™, GPS. Same as other i.MX processors, i.MX RT1020 also has rich audio features, including SPDIF and I2S audio interface.

The i.MX RT1020 applications processor can be used in areas such as industrial HMI, IoT, motor control and home appliances. The architecture's flexibility enables it to be used in a wide variety of other general embedded applications too. The i.MX processor provides all interfaces necessary to connect peripherals such as WLAN, Bluetooth™, GPS.

The more detail information about i.MX RT1020 can be found in the Datasheet and Reference Manual

2.2. Boot Mode configurations

The device has four boot modes (one is reserved for NXP's use). The boot mode is selected based on the binary value stored in the internal BOOT_MODE register. Switch (SW8-3 & SW8-4) is used to select the boot mode on the MIMXRT1020 EVK Board.

Table 2. Boot Mode pin settings

BOOT_MODE[1:0] (SW8-3 SW8-4)	BOOT Type
00	Boot From Fuses
01	Serial Downloader
10	Internal Boot
11	Reserved

Typically, the internal boot is selected for normal boot, which is configured by external BOOT_CFG GPIOs. The following [Table 3](#) shows the typical Boot Mode and Boot Device settings.

Table 3. Typical Boot Mode and Boot Device settings

SW8-1	SW8-2	SW8-3	SW8-4	Boot Device
OFF	OFF	ON	OFF	QSPI Flash
OFF	ON	ON	OFF	SD Card

NOTE

For more information about boot mode configuration, see the System Boot chapter of the MIMXRT1020 Reference Manual. (waiting for update)

For more information about MIMXRT1020 EVK boot device selection and configuration, see the main board schematic. (waiting for update)

2.3. Power tree

A DC 5 V external power supply is used to supply the MIMXRT1020 EVK Board at J2, and a slide switch SW1 is used to turn the Power ON/OFF. J23 and J9 also can be used to supply the EVK Board. Different power supply need to configure different Jumper setting of J1. [Table 4](#) shows the details:

Table 4. Jumper settings of Power Supply

Power Supply	J1 Setting
J2	1-2
J9	3-4
J23	5-6

NOTE

For some computers' USB, it cannot support 500ma before establishing communication. In this case, it is recommended to replace the computer or use the power adapter(J2) to power the EVK Board.

The power tree is shown in [Figure 4](#)

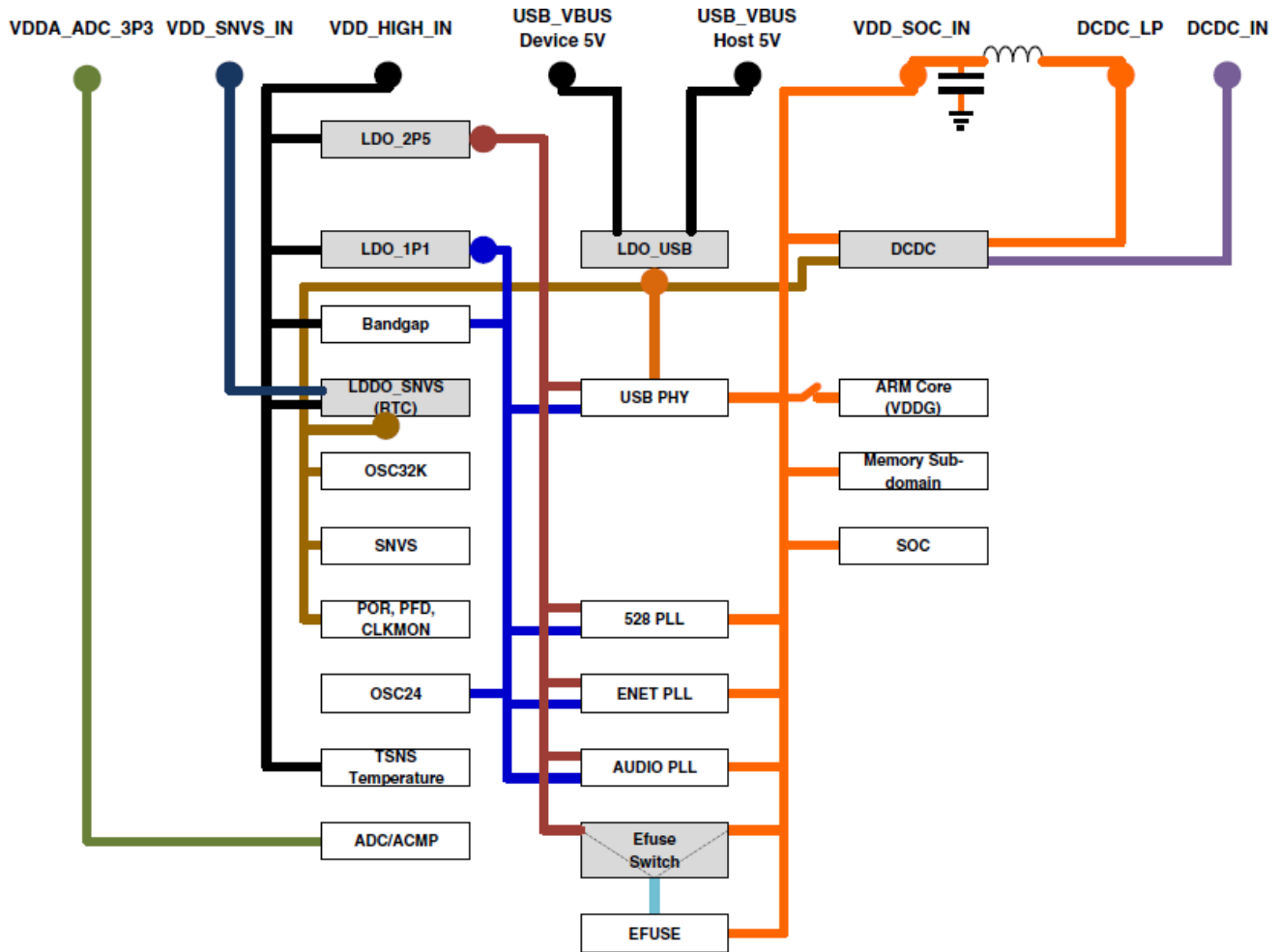

Figure 4. Power Tree

The power control logic of the MIMXRT1020 EVK board is shown in the Figure 5:

- It will power up SNVS, and then PMIC_REQ_ON will be switched on to enable external DC/DC to power up other power domains.
- ON/OFF button is used to switch ON/OFF PMIC_REQ_ON to control power modes.
- RESET button and WDOG output are used to reset the system power.

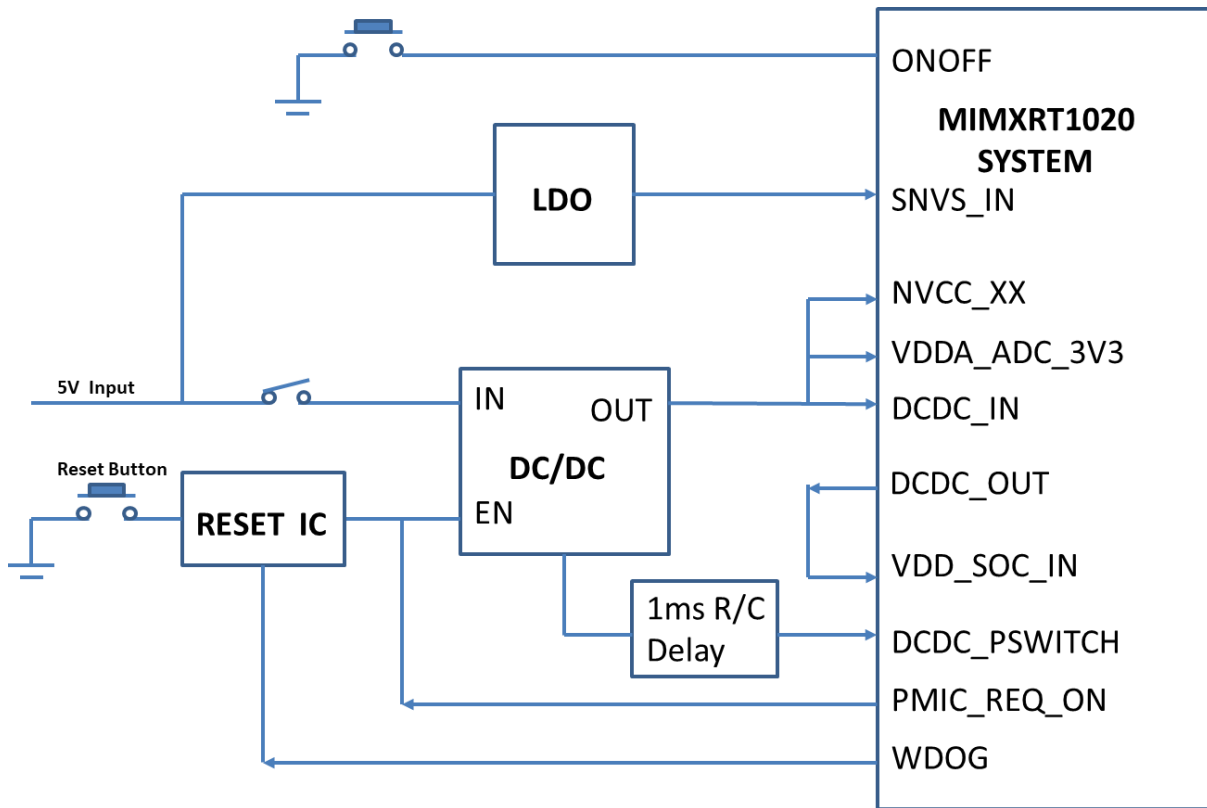

Figure 5. Power Control Diagram

The power rails on the board are shown in [Table 5](#).

Table 5. Power Rails

Power Rail	MIN (V)	TYP (V)	MAX (V)	Description
VDD_SOC_IN	0.925	--	1.26	Core supplies input voltage
VDD_HIGH_IN	3	3.3	3.6	VDD_HIGH_IN supply voltage
DCDC_IN	3	3.3	3.6	Power for DCDC
VDD_SNVS_IN	2.4	3	3.6	Power for SNVS and RTC
USB_OTG1_VBUS	4.4	5	5.5	Power for USB VBUS
VDDA_ADC	3	3.3	3.6	Power for 12-bit ADC
NVCC_SD0	3	3.3	3.6	Power for GPIO in SDIO1 bank (3.3V mode)

	1.65	1.8	1.95	Power for GPIO in SDIO1 bank (1.8V mode)
NVCC_GPIO	3	3.3	3.6	IO power for GPIO

2.4. SDRAM memory

One 256 Mb, 166 MHz SDRAM (MT48LC16M16A2P) is used on the EVK Board.

2.5. SD Card slot

There is a SD card slot(J15) on the MIMXRT1020 EVK Board. J15 is the Micro SD slot for USDHC1 interface. If the developer wants to boot from the SD Card, the boot device switch (SW8) settings should be: OFF, ON, ON, OFF, as shown in [Table 3](#).

2.6. QSPI flash

A 64 Mbit QSPI Flash is used on the MIMXRT1020 EVK Board. If the developer wants to boot from the QSPI Flash, the boot device switch(SW8) settings should be: OFF, OFF, ON, OFF, as shown in [Table 3](#).

2.7. Ethernet connector

There is one Ethernet Mac controller in the MIMXRT1020 processor. The Ethernet subsystem of the MIMXRT1020 EVK Board is provided by the KSZ8081RNB 10/100M Ethernet Transceiver (U11) and a RJ45 (J14) with integrated Magnetic.



Figure 6. Ethernet Connector RJ45

2.8. USB PHY connector

The MIMXRT1020 contains a integrated USB 2.0 PHYs capable of connecting to USB host/device systems at the USB low-speed (LS) rate of 1.5 Mbits/s, full-speed (FS) rate of 12 Mbits/s or at the USB 2.0 high-speed (HS) rate of 480 Mbits/s.

2.9. Audio input / output connector

The Audio CODEC used on the MIMXRT1020 EVK Board is Wolfson's Low Power, high quality Stereo Codec, WM8960. The MIMXRT1020 EVK Board include one headphone interface (J11), one onboard MIC (P1), two speaker interfaces (J12, J13). J11 is a 3.5 mm audio stereo headphone jack, which supports jack detect.

2.10. OpenSDA circuit (DAP-Link)

The OpenSDA circuit (CMSIS–DAP) is an open-standard serial and debug adapter. It bridges serial and debug communications between a USB host and an embedded target processor.

CMSIS-DAP features a mass storage device (MSD) bootloader, which provides a quick and easy mechanism for loading different CMSIS-DAP Applications such as flash programmers, run-control debug interfaces, serial-to-USB converters, and more. Two or more CMSIS-DAP applications can run simultaneously. For example, run-control debug application and serial-to-USB converter runs in parallel to provide a virtual COM communication interface while allowing code debugging via CMSIS-DAP with just single USB connection.

For the MIMXRT1020 EVK Board, J23 is the connector between the USB host and the target processor. Jumper to serial downloader mode to use stable DAP-Link debugger function. If developer wants to make OpenSDA going to the bootloader mode, and press SW5 when power on. Meanwhile, the OpenSDA supports drag/drop feature for U-Disk. First, use the serial downloader mode and drag/drop the image file to U-Disk. Then select QSPI Flash as boot device and reset the Board, the image will run.

2.11. JTAG connector

J16 is a standard 20-pin/2.54 mm Box Header Connector for JTAG. The pin definitions are shown in [Figure 7](#). Support SWD by default.

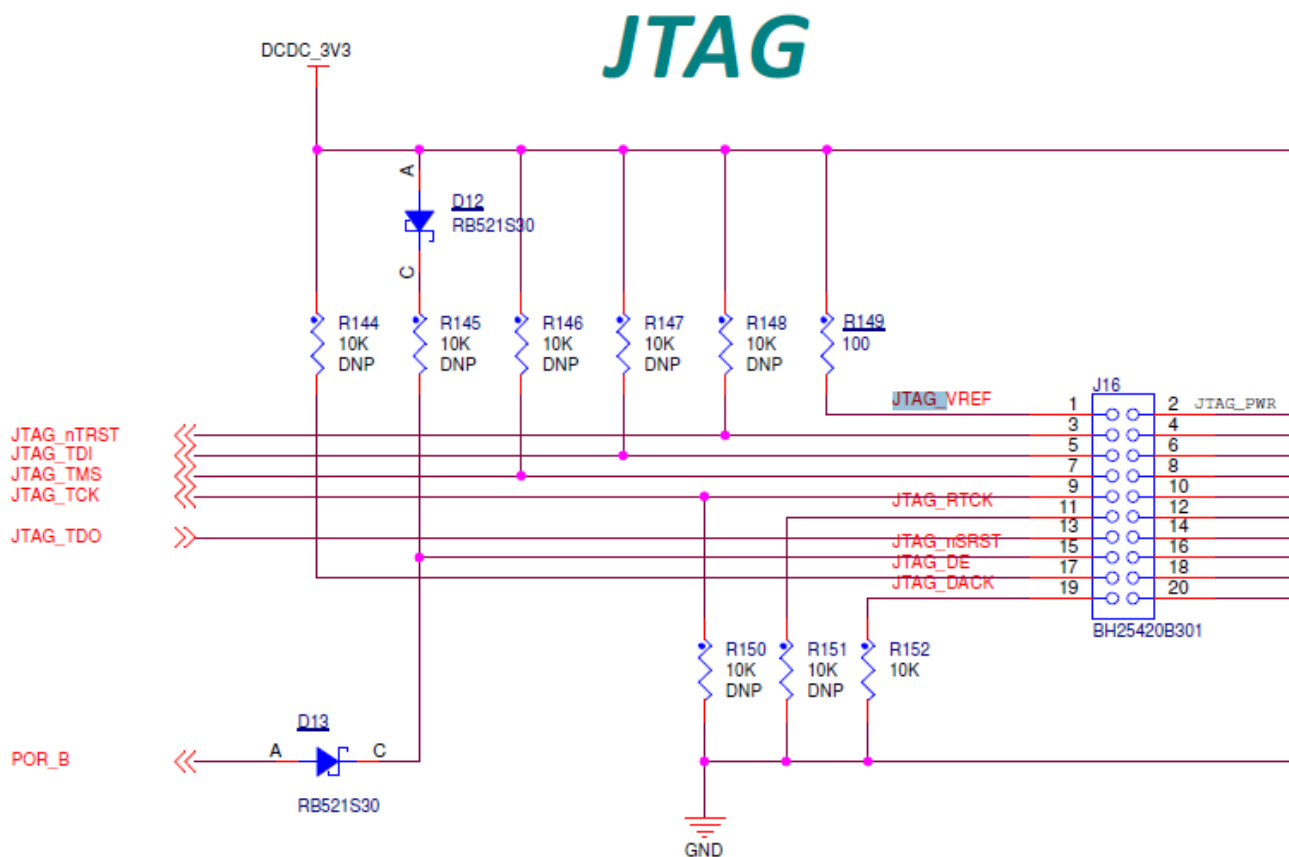

Figure 7. JTAG pin definitions

2.12. Arduino expansion port

J17 – J20 (unpopulated) is defined as Arduino Interface. The pin definitions of Arduino Interface are shown in [Table 6](#).

Table 6. Arduino Interface pin definitions

J17	J18
UART_RX/D0	A0/ADC0
UART_TX/D1	A1/ADC1
D2/INT0	A2/ADC2
D3/INT1/PWM/OC2B	A3/ADC3
D4/T0/XCK	A4/ADC4/SDA
D5/TI/PWM	A5/ADC5/SCL
D6/AIN0/PWM/OC0A	

D7/AIN1/PWM

J19	J20
D8/CLKO/ICP1	NC
D9/OC1A/PWM	IOREF
D10/SPI_CS	RESET
D11/OC2A/PWM/SPI_MOSI	3.3V
D12/SPI_MISO	5V
D13/SPI_CLK	GND
GND	GND
AREF	VIN
D14/I2C_SDA	
D15/I2C_SCL	

2.12.1. Power switch

SW1 is a slide switch to control the power of the MIMXRT1020 EVK Board when the power supply is from J2. The function of this switch is listed below:

- Sliding the switch to the ON position connects the 5 V power supply to the Evaluation board main power system.
- Sliding the switch to OFF position immediately removes all power from the board.

2.12.2. ON/OFF button

SW2 is the ON/OFF button for MIMXRT1020 EVK Board. A short pressing in OFF mode causes the internal power management state machine to change state to ON. In ON mode, a short pressing generates an interrupt (intended to be a software-controllable(power-down)). An approximate 5 seconds or more pressing causes a forced OFF. Both boot mode inputs can be disconnected.

2.12.3. Reset button

There are two Reset Button on the EVK Board. SW5 is the Power Reset Button. Pressing the SW5 in the Power On state will force to reset the system power except SNVS domain. The Processor will be immediately turn off and reinitiate a boot cycle from the Processor Power Off state. SW3 is POR Reset Button.

2.12.4. USER button

SW4 is the USER Button(GPIO5-00) for developers using. Pressing can produce changes in high and low levels.

2.13. User interface LED indicator

There are four LED status indicators located on the EVK Board. The functions of these LEDs include:

- Main Power Supply(D3)
Green: DC 5V main supply is normal.
Red: J2 input voltage is over 5.6V.
Off: the board is not powered.
- Reset RED LED(D15)
- OpenSDA LED(D16)
- USER LED(D5)

3. PCB information

The MIMXRT1020 EVK Board is made using standard 2-layer technology. The material used was FR-4. The PCB stack-up information is shown in [Table 7](#).

Table 7. Board stack-up information

Layer	Description	Copper(Oz)	Dielectric Thickness(mil)
Top	Signal, Power, GND	1	1.4
Dielectric	FR4	-	56
Bottom	Signal, Power, GND	1	1.4

4. EVK design files

The schematics, layout files, and gerber files (including Silkscreen) can be downloaded from nxp.com/MIMXRT1020-EVK(waiting for update).

5. Contents of the Evaluation Kit

Table 8. EVK contents

Item	Description
EVK Board	EVK Board with processor, memory, interfaces, etc
USB Cable	USB cable (Micro-B to Standard-A)

NOTE

Power adaptor, Micro SD Card are not standard parts of the Evaluation Kit.

6. Revision history

Table 9 summarizes the changes made to this document since the initial release.

Table 9. Revision history

Revision number	Date	Substantive changes
0	05/2018	Initial release

How to Reach Us:

Home Page:
nxp.com

Web Support:
nxp.com/support

Information in this document is provided solely to enable system and software implementers to use NXP products. There are no express or implied copyright licenses granted hereunder to design or fabricate any integrated circuits based on the information in this document. NXP reserves the right to make changes without further notice to any products herein.

NXP makes no warranty, representation, or guarantee regarding the suitability of its products for any particular purpose, nor does NXP assume any liability arising out of the application or use of any product or circuit, and specifically disclaims any and all liability, including without limitation consequential or incidental damages. "Typical" parameters that may be provided in NXP data sheets and/or specifications can and do vary in different applications, and actual performance may vary over time. All operating parameters, including "typicals", must be validated for each customer application by customer's technical experts. NXP does not convey any license under its patent rights nor the rights of others. NXP sells products pursuant to standard terms and conditions of sale, which can be found at the following address: nxp.com/SalesTermsandConditions.

While NXP has implemented advanced security features, all products may be subject to unidentified vulnerabilities. Customers are responsible for the design and operation of their applications and products to reduce the effect of these vulnerabilities on customer's applications and products, and NXP accepts no liability for any vulnerability that is discovered. Customers should implement appropriate design and operating safeguards to minimize the risks associated with their applications and products.

NXP, the NXP logo, NXP SECURE CONNECTIONS FOR A SMARTER WORLD, , Freescale, the Freescale logo, and Kinetis, are trademarks of NXP B.V. All other product or service names are the property of their respective owners. Arm and Cortex are registered trademarks of Arm Limited (or its subsidiaries) in the EU and/or elsewhere. All rights reserved.

© 2018 NXP B.V.

Document Number: MIMXRT1020EVKHUG
Rev. 0
05/2018



X-ON Electronics

Largest Supplier of Electrical and Electronic Components

Click to view similar products for [Development Boards & Kits - ARM category](#):

Click to view products by [NXP manufacturer](#):

Other Similar products are found below :

[SAFETI-HSK-RM48](#) [PICOHOBBITFL](#) [CC-ACC-MMK-2443](#) [TWR-MC-FRDMKE02Z](#) [EVALSPEAR320CPU](#) [EVB-SCMIMX6SX](#)
[MAX32600-KIT#](#) [TMDX570LS04HDK](#) [TXSD-SV70](#) [OM13080UL](#) [EVAL-ADUC7120QSPZ](#) [OM13082UL](#) [TXSD-SV71](#)
[YGRPEACHNORMAL](#) [OM13076UL](#) [PICODWARFFL](#) [YR8A77450HA02BG](#) [3580](#) [32F3348DISCOVERY](#) [ATTINY1607](#) [CURIOSITY](#)
[NANO](#) [PIC16F15376](#) [CURIOSITY NANO BOARD](#) [PIC18F47Q10](#) [CURIOSITY NANO](#) [VISIONSTK-6ULL V.2.0](#) [80-001428](#) [DEV-17717](#)
[EAK00360](#) [YR0K77210B000BE](#) [RTK7EKA2L1S00001BE](#) [MAX32651-EVKIT#](#) [SLN-VIZN-IOT](#) [LV18F V6 DEVELOPMENT SYSTEM](#)
[READY FOR AVR BOARD](#) [READY FOR PIC BOARD](#) [READY FOR PIC \(DIP28\)](#) [EVB-VF522R3](#) [AVRPLC16 V6 PLC SYSTEM](#)
[MIKROLAB FOR AVR XL](#) [MIKROLAB FOR PIC L](#) [MINI-AT BOARD - 5V](#) [MINI-M4 FOR STELLARIS](#) [MOD-09.Z](#) [BUGGY +](#)
[CLICKER 2 FOR PIC32MX + BLUETOOT](#) [1410](#) [LETS MAKE PROJECT PROGRAM. RELAY PIC](#) [LETS MAKE - VOICE](#)
[CONTROLLED LIGHTS](#) [LPC-H2294](#) [DSPIC-READY2 BOARD](#) [DSPIC-READY3 BOARD](#) [MIKROBOARD FOR ARM 64-PIN](#)
[MIKROLAB FOR AVR](#)