

Heterojunction Bipolar Transistor Technology (InGaP HBT)

High Efficiency/Linearity Amplifier

The MMA25312B is a 2-stage high efficiency InGaP HBT driver amplifier designed for use in 2400 MHz ISM applications, WLAN (802.11g), WiMAX (802.16e) and wireless broadband mesh networks. It is suitable for applications with frequencies from 2300 to 2700 MHz using simple external matching components with a 3 to 5 V supply.

- Typical Performance: $V_{CC1} = V_{CC2} = V_{BIAS} = 5 \text{ Vdc}$, $I_{CQ} = 150 \text{ mA}$

Frequency	P_{out} (dBm)	G_{ps} (dB)	EVM (%)	Test Signal
2450 MHz	20.5	27.4	3.0	WLAN (802.11g)
2350 MHz	23.0	27.2	3.0	WiMAX (802.16e)

Features

- Frequency: 2300–2700 MHz
- P1dB: 31 dBm @ 2500 MHz
- Power Gain: 26 dB @ 2500 MHz
- Third Order Output Intercept Point: 40 dBm @ 2500 MHz
- Active Bias Control (On-chip)
- Single 3 to 5 V Supply
- Single-ended Power Detector
- Cost-effective 12-pin, 3 mm QFN Surface Mount Plastic Package
- In Tape and Reel. T1 Suffix = 1,000 Units, 12 mm Tape Width, 7-inch Reel.

Table 1. Typical CW Performance ⁽¹⁾

Characteristic	Symbol	2300 MHz	2500 MHz	2700 MHz	Unit
Small-Signal Gain (S21)	G_p	26	26	24.5	dB
Input Return Loss (S11)	IRL	-14	-12	-12	dB
Output Return Loss (S22)	ORL	-11	-13	-15	dB
Power Output @ 1dB Compression	P1dB	30	31	29.8	dBm

1. $V_{CC1} = V_{CC2} = V_{BIAS} = 5 \text{ Vdc}$, $T_A = 25^\circ\text{C}$, 50 ohm system, CW Application Circuit

Table 3. Thermal Characteristics

Characteristic	Symbol	Value ⁽²⁾	Unit
Thermal Resistance, Junction to Case Case Temperature 91°C, $V_{CC1} = V_{CC2} = V_{BIAS} = 5 \text{ Vdc}$	$R_{\theta JC}$	92	°C/W

2. Refer to AN1955, *Thermal Measurement Methodology of RF Power Amplifiers*. Go to <http://www.freescale.com/rf>. Select Documentation/Application Notes - AN1955.

MMA25312BT1

2300–2700 MHz, 26 dB
31 dBm
InGaP HBT LINEAR AMPLIFIER



QFN 3 x 3

Table 2. Maximum Ratings

Rating	Symbol	Value	Unit
Supply Voltage	V_{CC}	6	V
Supply Current	I_{CC}	550	mA
RF Input Power	P_{in}	30	dBm
Storage Temperature Range	T_{stg}	-65 to +150	°C
Junction Temperature	T_J	175	°C

Table 4. Electrical Characteristics ($V_{CC1} = V_{CC2} = V_{BIAS} = 5$ Vdc, 2500 MHz, $T_A = 25^\circ\text{C}$, 50 ohm system, in Freescale CW Application Circuit)

Characteristic	Symbol	Min	Typ	Max	Unit
Small-Signal Gain (S21)	G_p	24.5	26	—	dB
Input Return Loss (S11)	IRL	—	-12	—	dB
Output Return Loss (S22)	ORL	—	-13	—	dB
Power Output @ 1dB Compression	P1dB	—	31	—	dBm
Third Order Output Intercept Point, Two-Tone CW	OIP3	—	40	—	dBm
Noise Figure	NF	—	3.8	—	dB
Supply Current	I_{CQ}	110	124	138	mA
Supply Voltage	V_{CC}	—	5	—	V

Table 5. ESD Protection Characteristics

Test Methodology	Class
Human Body Model (per JESD 22-A114)	2
Machine Model (per EIA/JESD 22-A115)	A
Charge Device Model (per JESD 22-C101)	IV

Table 6. Moisture Sensitivity Level

Test Methodology	Rating	Package Peak Temperature	Unit
Per JESD22-A113, IPC/JEDEC J-STD-020	1	260	$^\circ\text{C}$

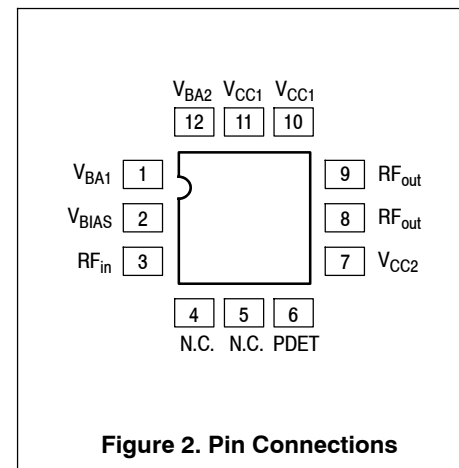
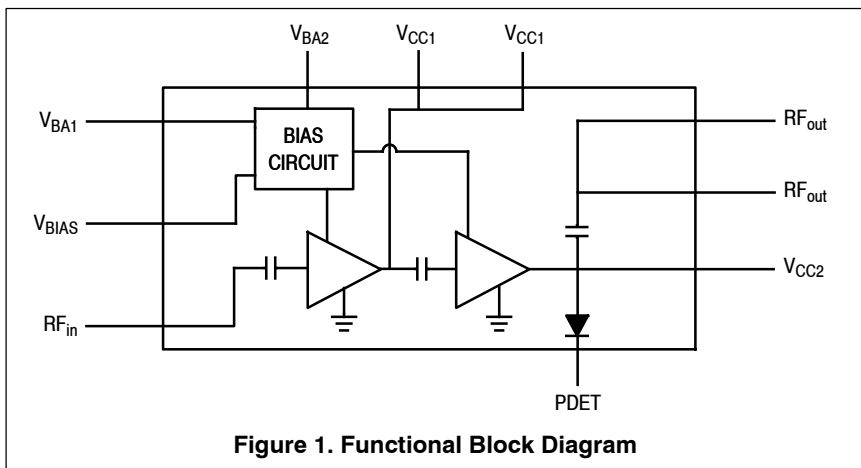

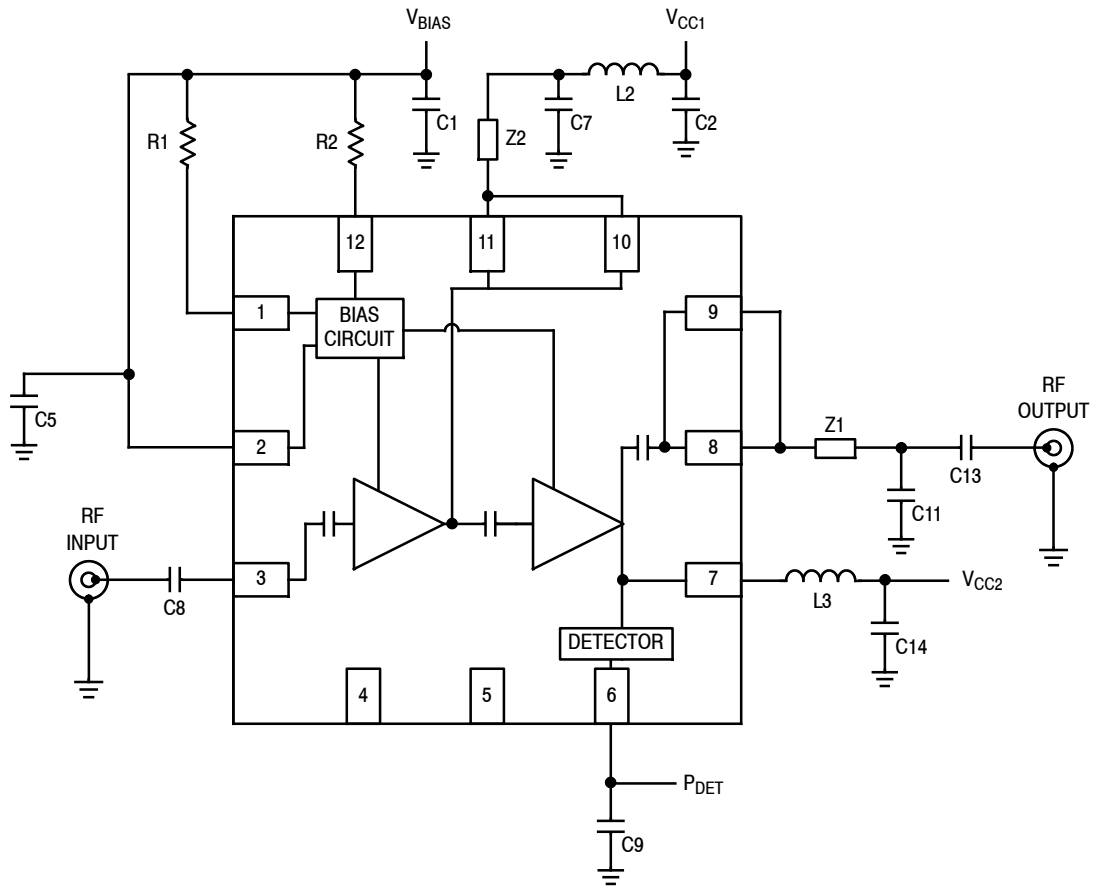

Z1 0.140" x 0.030" Microstrip
 Z2 0.073" x 0.030" Microstrip

Figure 3. MMA25312BT1 Test Circuit Schematic — 2500 MHz, 5 Volt Operation

Table 7. MMA25312BT1 Test Circuit Component Designations and Values — 2500 MHz, 5 Volt Operation

Part	Description	Part Number	Manufacturer
C1, C2	1 μ F Chip Capacitors	GRM155R61A105KE15	Murata
C3, C4, C6, C10, C12, C15	Components Not Placed		
C5, C9	100 pF Chip Capacitors	GRM1555C1H101JA01	Murata
C7	8.2 pF Chip Capacitor	04023J8R2BBS	AVX
C8, C13	22 pF Chip Capacitors	04023J22R0BBS	AVX
C11	1.5 pF Chip Capacitor	04023J1R5BBS	AVX
C14	4.7 μ F Chip Capacitor	GRM188R60J475KE19D	Murata
L2	1.2 nH Chip Inductor	LL1608-FH1N2S	TOKO
L3	22 nH Chip Inductor	LL1608-FH22N0S	TOKO
R1	330 Ω , 1/16 W Chip Resistor	RC0402JR-07330RL	Yageo
R2	1210 Ω , 1/16 W Chip Resistor	RC0402JR-071K21L	Yageo
R3	Component Not Placed		
PCB	0.014", $\epsilon_r = 3.7$	FR408	Isola

Note: Component numbers C3, C4, C6, C10, C12, C15 and R3 are labeled on board but not placed.

Note: Component L1 intentionally omitted.

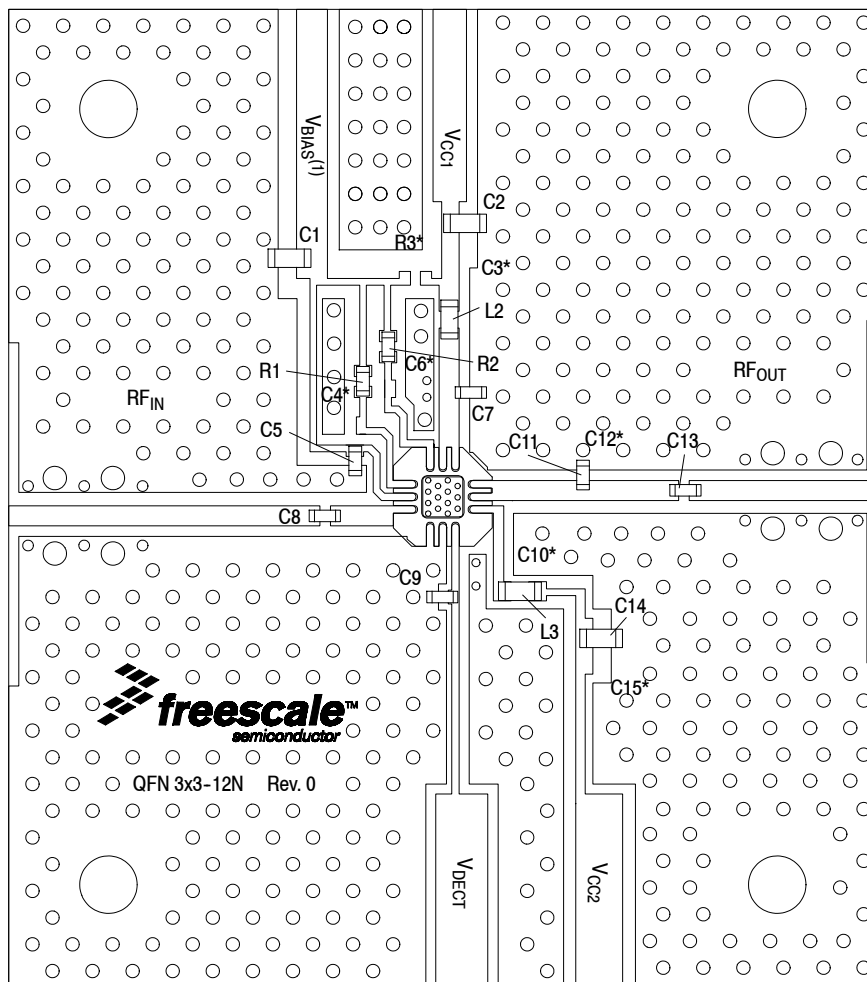

(1) V_{BIAS} [Board] supplies V_{BA1} , V_{BA2} and V_{BIAS} [Device].
 Note: Component numbers C3*, C4*, C6*, C10*, C12*, C15* and R3* are labeled on board but not placed.

Figure 4. MMA25312BT1 Test Circuit Component Layout — 2500 MHz, 5 Volt Operation

Table 7. MMA25312BT1 Test Circuit Component Designations and Values — 2500 MHz, 5 Volt Operation

Part	Description	Part Number	Manufacturer
C1, C2	1 μ F Chip Capacitors	GRM155R61A105KE15	Murata
C3, C4, C6, C10, C12, C15	Components Not Placed		
C5, C9	100 pF Chip Capacitors	GRM1555C1H101JA01	Murata
C7	8.2 pF Chip Capacitor	04023J8R2BBS	AVX
C8, C13	22 pF Chip Capacitors	04023J22R0BBS	AVX
C11	1.5 pF Chip Capacitor	04023J1R5BBS	AVX
C14	4.7 μ F Chip Capacitor	GRM188R60J475KE19D	Murata
L2	1.2 nH Chip Inductor	LL1608-FH1N2S	TOKO
L3	22 nH Chip Inductor	LL1608-FH22N0S	TOKO
R1	330 Ω , 1/16 W Chip Resistor	RC0402JR-07330RL	Yageo
R2	1210 Ω , 1/16 W Chip Resistor	RC0402JR-071K21L	Yageo
R3	Component Not Placed		
PCB	0.014", $\epsilon_r = 3.7$	FR408	Isola

Note: Component L1 intentionally omitted.

(Component Designations and Values table repeated for reference.)

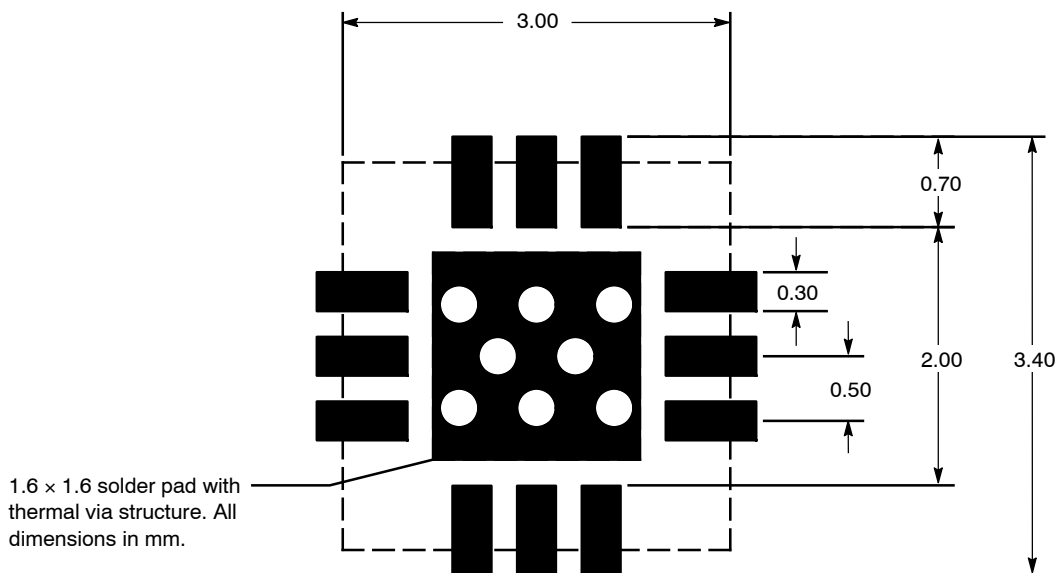
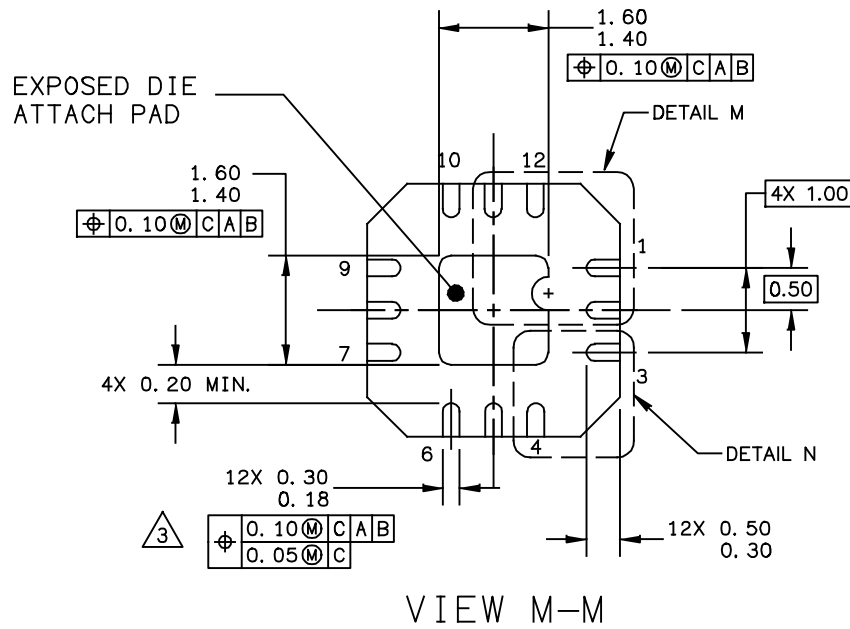
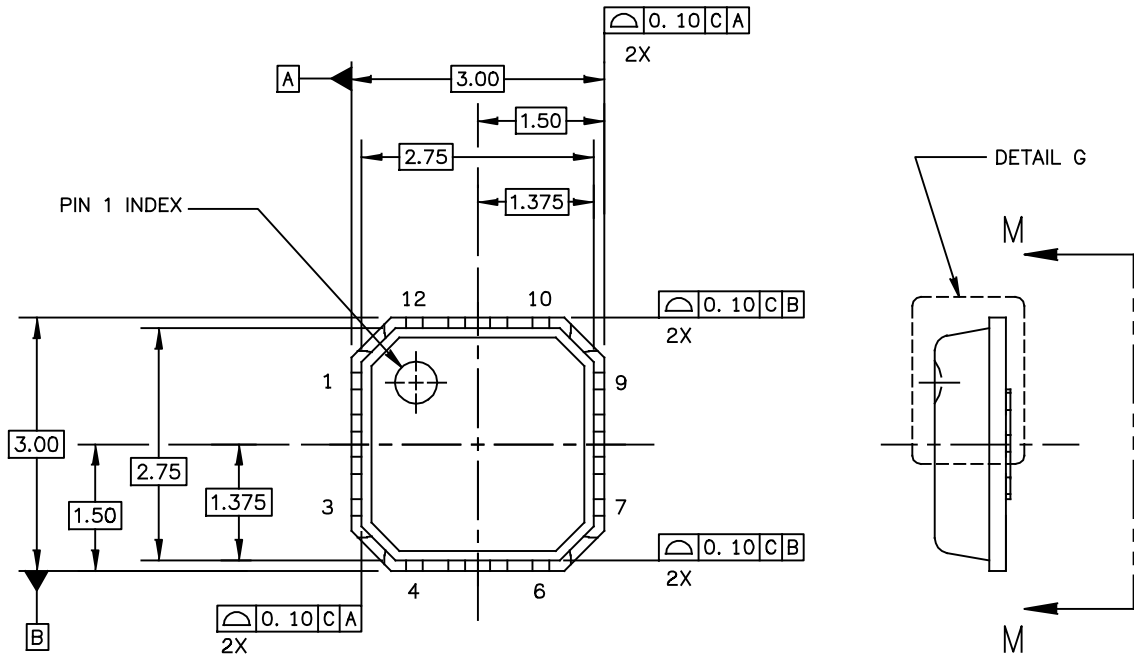

Figure 5. PCB Pad Layout for QFN 3 x 3



Figure 6. Product Marking

PACKAGE DIMENSIONS



VIEW M-M

© FREESCALE SEMICONDUCTOR, INC. ALL RIGHTS RESERVED.	MECHANICAL OUTLINE	PRINT VERSION NOT TO SCALE	
TITLE: THERMALLY ENHANCED QUAD FLAT NON-LEADED PACKAGE (QFN) 12 TERMINAL, 0.5 PITCH (3X3X0.85)	DOCUMENT NO: 98ASA00227D	REV: 0	
	CASE NUMBER: 2131-01	14 MAY 2010	
	STANDARD: NON-JEDEC		

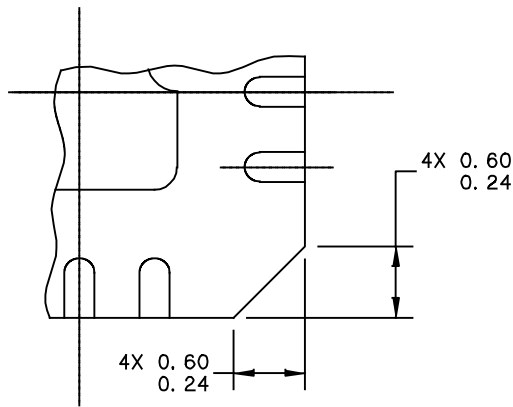

DETAIL N
CORNER CONFIGURATION

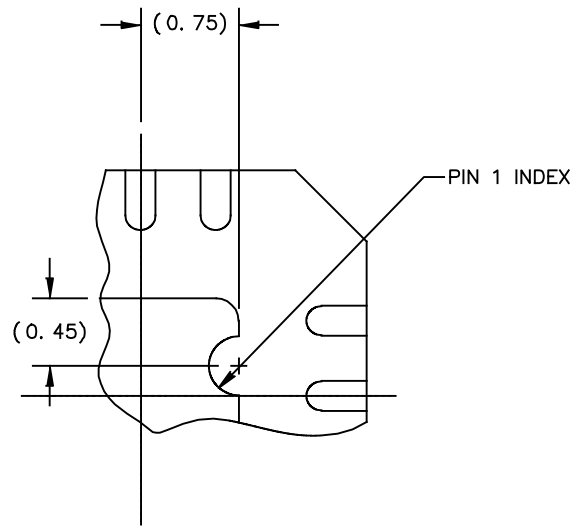

DETAIL M
PIN 1 BACKSIDE INDEX

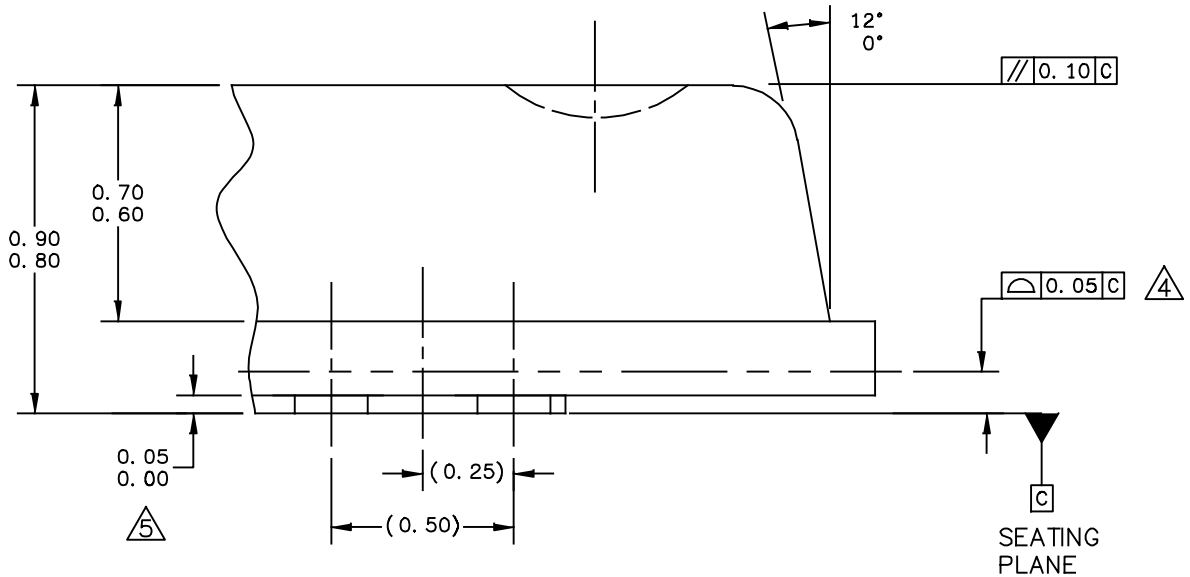

DETAIL G
VIEW ROTATED 90° CW

© FREESCALE SEMICONDUCTOR, INC. ALL RIGHTS RESERVED.	MECHANICAL OUTLINE	PRINT VERSION NOT TO SCALE	
TITLE: THERMALLY ENHANCED QUAD FLAT NON-LEADED PACKAGE (QFN) 12 TERMINAL, 0.5 PITCH (3X3X0.85)	DOCUMENT NO: 98ASA00227D	REV: 0	
	CASE NUMBER: 2131-01	14 MAY 2010	
	STANDARD: NON-JEDEC		

NOTE:

1. ALL DIMENSIONS ARE IN MILLIMETERS.
2. DIMENSIONING & TOLERANCING PER ASME Y14.5 – 2009.
3. THIS DIMENSION APPLIES TO PLATED TERMINAL AND IS MEASURED BETWEEN 0.15 AND 0.30 MM FROM TERMINAL TIP.
4. BILATERAL COPLANARITY ZONE APPLIES TO THE EXPOSED PAD AS WELL AS THE TERMINALS.
5. THIS DIMENSION APPLIED ONLY FOR TERMINALS.

© FREESCALE SEMICONDUCTOR, INC. ALL RIGHTS RESERVED.	MECHANICAL OUTLINE	PRINT VERSION NOT TO SCALE	
TITLE: THERMALLY ENHANCED QUAD FLAT NON-LEADED PACKAGE (QFN) 12 TERMINAL, 0.5 PITCH (3X3X0.85)	DOCUMENT NO: 98ASA00227D	REV: 0	
	CASE NUMBER: 2131-01	14 MAY 2010	
	STANDARD: NON-JEDEC		

Refer to the following resources to aid your design process.

Application Notes

- AN1955: Thermal Measurement Methodology of RF Power Amplifiers
- AN3100: General Purpose Amplifier and MMIC Biasing

Software

- .s2p File

Development Tools

- Printed Circuit Boards

For Software and Tools, do a Part Number search at <http://www.freescale.com>, and select the “Part Number” link. Go to Software & Tools on the part’s Product Summary page to download the respective tool.

FAILURE ANALYSIS

At this time, because of the physical characteristics of the part, failure analysis is limited to electrical signature analysis. In cases where Freescale is contractually obligated to perform failure analysis (FA) services, full FA may be performed by third party vendors with moderate success. For updates contact your local Freescale Sales Office.

REVISION HISTORY

The following table summarizes revisions to this document.

Revision	Date	Description
0	Sept. 2012	<ul style="list-style-type: none"> • Initial Release of Data Sheet
1	Mar. 2013	<ul style="list-style-type: none"> • Added typical performance bullet and frequency table for WLAN (802.11g) and WiMAX (802.16e), p. 1 • Table 7, Test Circuit Component Designations and Values - 2500 MHz, 5 Volt Operation: updated R1 description from 430 Ω, 1/16 Ω Chip Resistor to 330 Ω, 1/16 W Chip Resistor and R1 part number from RC0402JR-07430RL to RC0402JR-07330RL. Updated R2 description from 1.6 kΩ, 1/16 W Chip Resistor to 1210 Ω, 1/16 W Chip Resistor and R2 part number from RC0402JR-071K60L to RC0402JR-071K21L to reflect WiMAX, WLAN circuit performance, pp. 3, 4 • Removed Fig. 5, Test Circuit Schematic - 2500 MHz, 3.3 Volt Operation, Table 8, Test Circuit Component Designations and Values - 2500 MHz, 3.3 Volt Operation and Fig. 6, Test Circuit Component Layout - 2500 MHz, 3.3 Volt Operation, pp. 5, 6
2	Sept. 2014	<ul style="list-style-type: none"> • Table 2, Maximum Ratings: updated Junction Temperature from 150°C to 175°C to reflect recent test results of the device, p. 1 • Added Failure Analysis information, p. 9

How to Reach Us:

Home Page:
freescale.com

Web Support:
freescale.com/support

Information in this document is provided solely to enable system and software implementers to use Freescale products. There are no express or implied copyright licenses granted hereunder to design or fabricate any integrated circuits based on the information in this document.

Freescale reserves the right to make changes without further notice to any products herein. Freescale makes no warranty, representation, or guarantee regarding the suitability of its products for any particular purpose, nor does Freescale assume any liability arising out of the application or use of any product or circuit, and specifically disclaims any and all liability, including without limitation consequential or incidental damages. "Typical" parameters that may be provided in Freescale data sheets and/or specifications can and do vary in different applications, and actual performance may vary over time. All operating parameters, including "typicals," must be validated for each customer application by customer's technical experts. Freescale does not convey any license under its patent rights nor the rights of others. Freescale sells products pursuant to standard terms and conditions of sale, which can be found at the following address: freescale.com/SalesTermsandConditions.

Freescale and the Freescale logo are trademarks of Freescale Semiconductor, Inc., Reg. U.S. Pat. & Tm. Off. All other product or service names are the property of their respective owners.

© 2012–2014 Freescale Semiconductor, Inc.

X-ON Electronics

Largest Supplier of Electrical and Electronic Components

Click to view similar products for [RF Amplifier](#) category:

Click to view products by [NXP](#) manufacturer:

Other Similar products are found below :

[A82-1](#) [BGA622H6820XTSA1](#) [BGA 728L7 E6327](#) [BGB719N7ESDE6327XTMA1](#) [HMC397-SX](#) [HMC405](#) [HMC561-SX](#) [HMC8120-SX](#)
[HMC8121-SX](#) [HMC-ALH382-SX](#) [HMC-ALH476-SX](#) [SE2433T-R](#) [SMA3101-TL-E](#) [SMA39](#) [A66-1](#) [A66-3](#) [A67-1](#) [LX5535LQ](#) [LX5540LL](#)
[MAAM02350](#) [HMC3653LP3BETR](#) [HMC549MS8GETR](#) [HMC-ALH435-SX](#) [SMA101](#) [SMA32](#) [SMA411](#) [SMA531](#) [SST12LP17E-XX8E](#)
[SST12LP19E-QX6E](#) [WPM0510A](#) [HMC5929LS6TR](#) [HMC5879LS7TR](#) [HMC1126](#) [HMC1087F10](#) [HMC1086](#) [HMC1016](#) [SMA1212](#)
[MAX2689EWS+T](#) [MAAMSS0041TR](#) [MAAM37000-A1G](#) [LTC6430AIUF-15#PBF](#) [CHA5115-QDG](#) [SMA70-2](#) [SMA4011](#) [A231](#) [HMC-](#)
[AUH232](#) [LX5511LQ](#) [LX5511LQ-TR](#) [HMC7441-SX](#) [HMC-ALH310](#)