

Xtrinsic MMA52xxAKW PSI5 Inertial Sensor

The MMA52xxAKW family, a SafeAssure solution, includes the PSI5 Version 1.3 asynchronous mode compatible overdamped X-axis satellite accelerometers.

Features

- $\pm 60g$ to $\pm 480g$ Full-Scale Range
- 400 Hz, 3-Pole Low-Pass Filter
- Single Pole, High-Pass Filter with Fast Startup and Output Rate Limiting
- PSI5 Version 1.3 Asynchronous Mode Compatible
 - PSI5-A10P-228/1L Compatible
 - Baud Rate: 125 kBaud
 - 10-bit Data
 - Even Parity Error Detection
- 16 μs Internal Sample Rate, with Interpolation to 1 μs
- Pb-Free 16-Pin QFN, 6 by 6 Package
- Qualified AECQ100, Revision G, Grade 1 (-40°C to +125°C)
(<http://www.aecouncil.com/>)

Typical Applications

- Airbag Front and Side Crash Detection

MMA52xxAKW

Bottom View

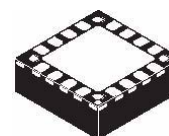

16-PIN QFN
CASE 2086-01

Top View

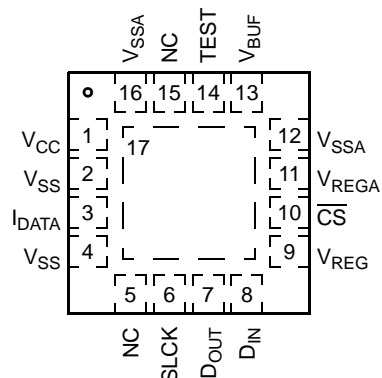

PIN CONNECTIONS

ORDERING INFORMATION

Device	Axis	Range	Package	Shipping
MMA5206AKW	X	60g	2086-01	Tubes
MMA5212AKW	X	120g	2086-01	Tubes
MMA5224AKW	X	240g	2086-01	Tubes
MMA5248AKW	X	480g	2086-01	Tubes
MMA5206AKWR2	X	60g	2086-01	Tape & Reel
MMA5212AKWR2	X	120g	2086-01	Tape & Reel
MMA5224AKWR2	X	240g	2086-01	Tape & Reel
MMA5248AKWR2	X	480g	2086-01	Tape & Reel

Application Diagram

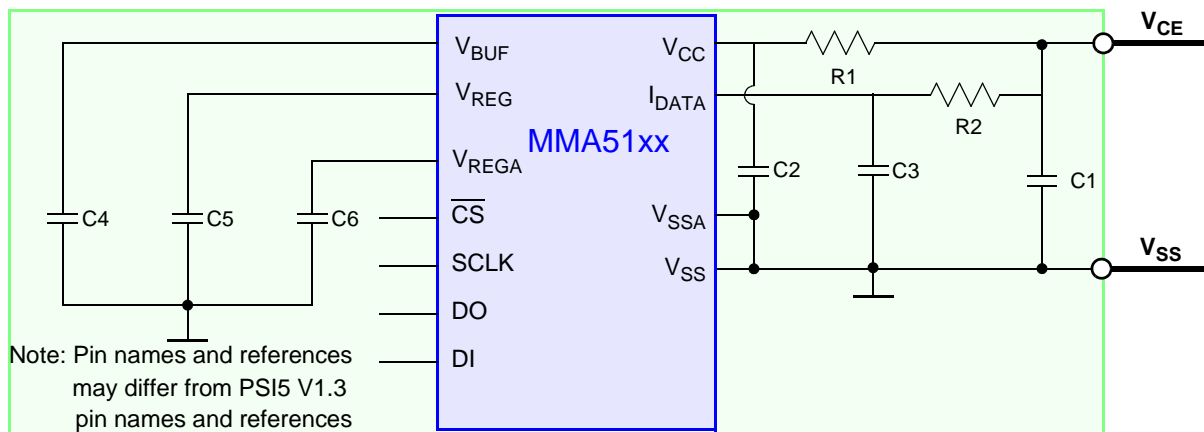

Figure 1. Application Diagram

External Component Recommendations			
Ref Des	Type	Description	Purpose
C1	Ceramic	2.2 nF, 10%, 50V minimum, X7R	V _{CC} Power Supply Decoupling and Signal Damping
C3	Ceramic	470 pF, 10%, 50V minimum, X7R	I _{DATA} Filtering and Signal Damping
C2	Ceramic	15 nF, 10%, 50V minimum, X7R	V _{CC} Power Supply Decoupling
C4, C5, C6	Ceramic	1 μF, 10%, 10V minimum, X7R	Voltage Regulator Output Capacitor(s)
R1	General Purpose	82Ω, 5%, 200 PPM	V _{CC} Filtering and Signal Damping
R2	General Purpose	27Ω, 5%, 200 PPM	I _{DATA} Filtering and Signal Damping

Device Orientation

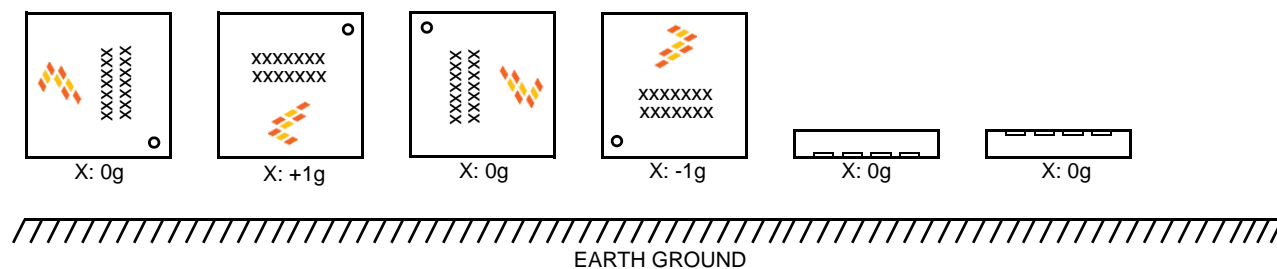

Figure 2. Device Orientation Diagram

Internal Block Diagram

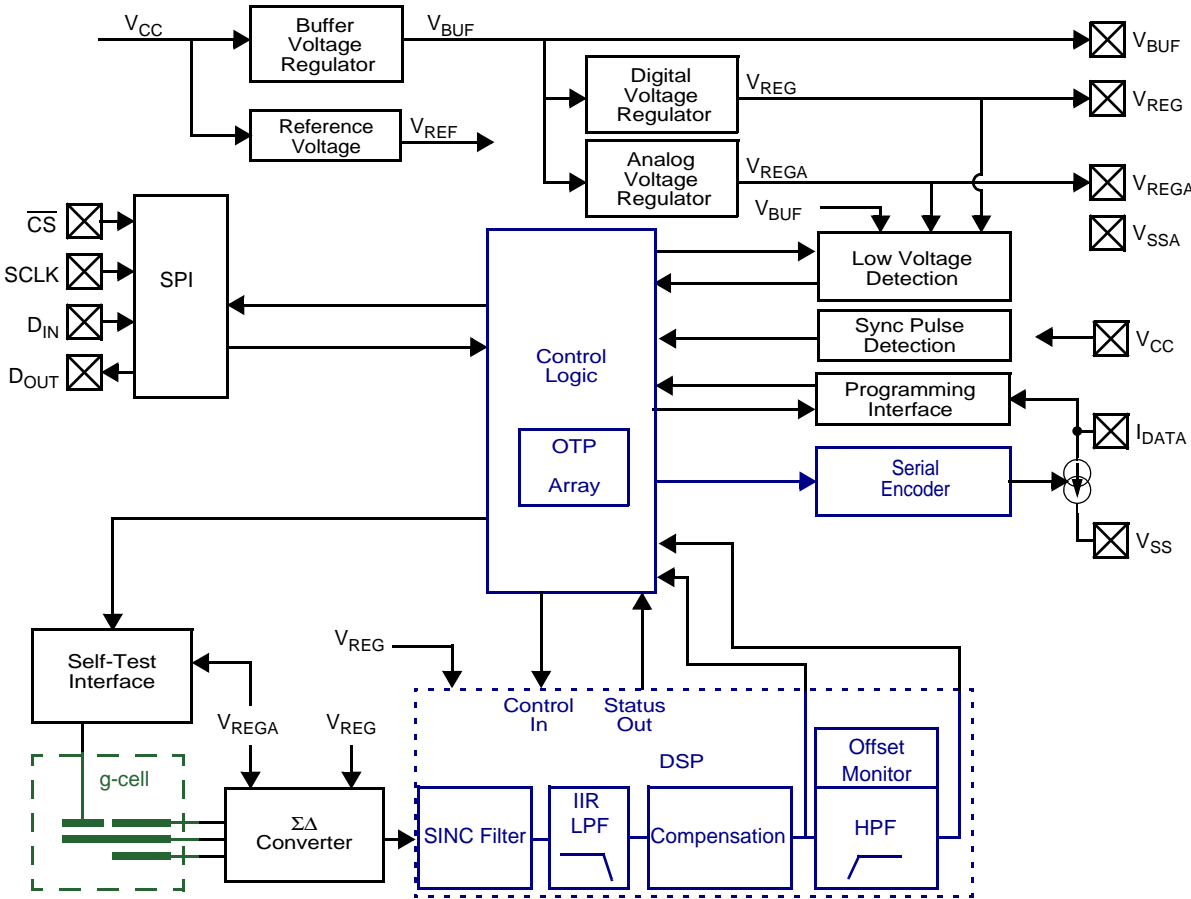

Figure 3. Block Diagram

1 Pin Connections

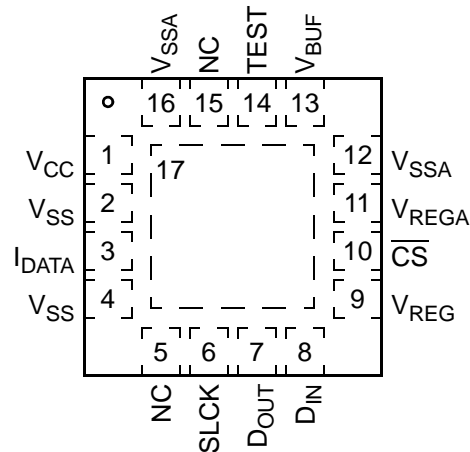

Figure 4. Top View, 16-Pin QFN Package

Table 1. Pin Description

Pin	Pin Name	Formal Name	Definition
1	V _{CC}	Supply	This pin is connected to the PSI5 power and data line through a resistor and supplies power to the device. An external capacitor must be connected between this pin and V _{SS} . Reference Figure 1 .
2	V _{SS}	Digital GND	This pin is the power supply return node for the digital circuitry.
3	I _{DATA}	Response Current	This pin is connected to the PSI5 power and data line through a resistor and modulates the response current for PSI5 communication. Reference Figure 1 .
4	V _{SS}	Digital GND	This pin is the power supply return node for the digital circuitry.
5	NC	Not Connected	This pin must be left unconnected in the application.
6	SCLK	SPI Clock	This input pin provides the serial clock to the SPI port for test purposes. An internal pulldown device is connected to this pin. This pin must be grounded or left unconnected in the application.
7	D _{OUT}	SPI Data Out	This pin functions as the serial data output from the SPI port for test purposes. This pin must be left unconnected in the application.
8	D _{IN}	SPI Data In	This pin functions as the serial data input to the SPI port for test purposes. An internal pulldown device is connected to this pin. This pin must be grounded or left unconnected in the application.
9	V _{REG}	Digital Supply	This pin is connected to the power supply for the internal digital circuitry. An external capacitor must be connected between this pin and V _{SS} . Reference Figure 1 .
10	CS	Chip Select	This input pin provides the chip select to the SPI port for test purposes. An internal pullup device is connected to this pin. This pin must be left unconnected in the application.
11	V _{REGA}	Analog Supply	This pin is connected to the power supply for the internal analog circuitry. An external capacitor must be connected between this pin and V _{SSA} . Reference Figure 1 .
12	V _{SSA}	Analog GND	This pin is the power supply return node for the analog circuitry.
13	V _{BUF}	Power Supply	This pin is connected to a buffer regulator for the internal circuitry. The buffer regulator supplies both the analog (V _{REGA}) and digital (V _{REG}) supplies to provide immunity from EMC and supply dropouts on V _{CC} . An external capacitor must be connected between this pin and V _{SS} . Reference Figure 1 .
14	TEST	Test Pin	This pin is must be grounded or left unconnected in the application.
15	NC	Not Connected	This pin must be left unconnected in the application.
16	V _{SSA}	Analog GND	This pin is the power supply return node for the analog circuitry.
17	PAD	Die Attach Pad	This pin is the die attach flag, and is internally connected to V _{SS} .
	Corner Pads	Corner Pads	The corner pads are internally connected to V _{SS} .

2 Electrical Characteristics

2.1 Maximum Ratings

Maximum ratings are the extreme limits to which the device can be exposed without permanently damaging it.

#	Rating	Symbol	Value	Unit	
1	Supply Voltage (V_{CC} , I_{DATA})				(3)
2	Reverse Current ≤ 160 mA, $t \leq 80$ ms	V_{CC_REV}	-0.7	V	(3)
3	Continuous	V_{CC_MAX}	+20.0	V	(9)
	Transient (< 10 μ s)	V_{CC_TRANS}	+25.0	V	
4	V_{BUF_Test}		-0.3 to +4.2	V	(3)
5	V_{REG} , V_{REGA} , $SCLK$, \overline{CS} , D_{IN} , D_{OUT}		-0.3 to +3.0	V	(3)
6	Powered Shock (six sides, 0.5 ms duration)	g_{pms}	± 2000	g	(3)
7	Unpowered Shock (six sides, 0.5 ms duration)	g_{shock}	± 2500	g	(3)
8	Drop Shock (to concrete, tile or steel surface, 10 drops, any orientation)	h_{DROP}	1.2	m	(5)
9	Electrostatic Discharge (per AECQ100)				
10	External Pins (V_{CC} , I_{DATA} , V_{SS} , V_{SSA}), HBM (100 pF, 1.5 k Ω)	V_{ESD}	± 4000	V	(5)
11	HBM (100 pF, 1.5 k Ω)	V_{ESD}	± 2000	V	(5)
12	CDM ($R = 0\Omega$)	V_{ESD}	± 1500	V	(5)
	MM (200 pF, 0Ω)	V_{ESD}	± 200	V	(5)
13	Temperature Range				
14	Storage	T_{stg}	-40 to +125	$^{\circ}$ C	(3)
	Junction	T_J	-40 to +150	$^{\circ}$ C	(9)
15	Thermal Resistance	θ_{JC}	2.5	$^{\circ}$ C/W	(9, 14)

2.2 Operating Range

$V_L \leq (V_{CC} - V_{SS}) \leq V_H$, $T_L \leq T_A \leq T_H$, $\Delta T \leq 25$ K/min, unless otherwise specified.

#	Characteristic	Symbol	Min	Typ	Max	Units	
16	Supply Voltage	V_{CC}	V_L 4.2	—	V_H 17.0	V	(1)
17		V_{CC_UV}	$V_{VCC_UV_F}$	—	V_L	V	(9)
18	Operating Temperature Range	T_A	T_L -40	—	T_H +105	$^{\circ}$ C	(1)
19		T_A	-40	—	+125	$^{\circ}$ C	(3)

2.3 Electrical Characteristics - Supply and I/O

$V_L \leq (V_{CC} - V_{SS}) \leq V_H$, $T_L \leq T_A \leq T_H$, $\Delta T \leq 25$ K/min, unless otherwise specified.

#	Characteristic	Symbol	Min	Typ	Max	Units	
20	Quiescent Supply Current *	I_{IDLE}	4.0	—	8.0	mA	(1)
21	Modulation Supply Current *	I_{MOD}	$I_{IDLE} + 22.0$	$I_{IDLE} + 26.0$	$I_{IDLE} + 30.0$	mA	(1)
22	Inrush Current (Power On until V_{BUF} , V_{REG} , V_{REGA} Stable)	I_{INRUSH}	—	—	30	mA	(3)
23	Internally Regulated Voltages *	V_{BUF}	3.60	3.80	4.00	V	(1)
24	V_{REG} *	V_{REG}	2.425	2.50	2.575	V	(1)
25	V_{REGA} *	V_{REGA}	2.425	2.50	2.575	V	(1)
26	Low Voltage Detection Threshold						
27	V_{CC} Falling	$V_{VCC_UV_F}$	3.40	3.70	4.0	V	(3, 6)
28	V_{BUF} Falling	$V_{BUF_UV_F}$	2.95	3.15	3.35	V	(3, 6)
29	V_{REG} Falling	$V_{REG_UV_F}$	2.15	2.25	2.35	V	(3, 6)
29	V_{REGA} Falling	$V_{REGA_UV_F}$	2.15	2.25	2.35	V	(3, 6)
30	Hysteresis						
31	V_{CC}	V_{CC_HYST}	0.10	0.25	0.40	V	(3)
32	V_{BUF}	V_{BUF_HYST}	0.05	0.10	0.15	V	(3)
33	V_{REG}	V_{REG_HYST}	0.05	0.10	0.15	V	(3)
33	V_{REGA}	V_{REGA_HYST}	0.05	0.10	0.15	V	(3)
34	External Capacitor (V_{BUF} , V_{REG} , V_{REGA}) Capacitance		500	1000	1500	nF	(9)
35	ESR (including interconnect resistance)	ESR	0	—	200	m Ω	(9)
36	Output High Voltage (DO) $I_{Load} = 100 \mu A$	V_{OH}	$V_{REG} - 0.1$	—	—	V	(9)
37	Output Low Voltage (DO) $I_{Load} = 100 \mu A$	V_{OL}	—	—	0.1	V	(9)
38	Input High Voltage CS, SCLK, DI	V_{IH}	$0.7 * V_{REG}$	—	—	V	(9)
39	Input Low Voltage \overline{CS} , SCLK, DI	V_{IL}	—	—	$0.3 * V_{REG}$	V	(9)
40	Input Current High (at V_{IH}) (DI)	I_{IH}	-100	—	-10	μA	(9)
41	Low (at V_{IL}) (CS)	I_{IL}	10	—	100	μA	(9)
42	Pulldown Resistance (SCLK)	R_{PD}	20	∞	100	k Ω	(9)

2.4 Electrical Characteristics - Sensor and Signal Chain

$V_L \leq (V_{CC} - V_{SS}) \leq V_H$, $T_L \leq T_A \leq T_H$, $\Delta T \leq 25$ K/min, unless otherwise specified.

#	Characteristic	Symbol	Min	Typ	Max	Units	
43	Sensitivity (10-bit output @ 100 Hz, referenced to 0 Hz) ±60g Range	* SENS	—	8	—	LSB/g	(1)
44	±120g Range	* SENS	—	4	—	LSB/g	(1)
45	±240g Range	* SENS	—	2	—	LSB/g	(1)
46	±480g Range	* SENS	—	1	—	LSB/g	(1)
Total Sensitivity Error (including non-linearity)							
47	$T_A = 25^\circ\text{C}$, $\leq \pm 240\text{g}$	* ΔSENS_{240}	-5	—	+5	%	(1)
48	$T_L \leq T_A \leq T_H$, $\leq \pm 240\text{g}$	* ΔSENS_{240}	-7	—	+7	%	(1)
49	$T_L \leq T_A \leq T_H$, $\leq \pm 240\text{g}$, $V_{VCC_UV_F} \leq V_{CC} \leq V_L$	* ΔSENS_{240}	-7	—	+7	%	(9)
50	$T_A = 25^\circ\text{C}$, $> \pm 240\text{g}$	* ΔSENS_{480}	-5	—	+5	%	(1)
51	$T_L \leq T_A \leq T_H$, $> \pm 240\text{g}$	* ΔSENS_{480}	-7	—	+7	%	(1)
52	$T_L \leq T_A \leq T_H$, $> \pm 240\text{g}$, $V_{VCC_UV_F} \leq V_{CC} \leq V_L$	* ΔSENS_{480}	-7	—	+7	%	(9)
Digital Offset Before Offset Cancellation							
53	10-bit	* $\text{OFF}_{10\text{Bit}}$	-52	0	+52	LSB	(1)
54	10-bit, $T_L \leq T_A \leq T_H$, $V_{VCC_UV_F} \leq V_{CC} \leq V_L$	* $\text{OFF}_{10\text{Bit}}$	-52	0	+52	LSB	(9)
Digital Offset After Offset Cancellation							
55	10-bit, 0.3 Hz HPF or 0.1 Hz HPF	* $\text{OFF}_{10\text{Bit}}$	-1	0	+1	LSB	(1)
56	10-bit, 0.04 Hz HPF	* $\text{OFF}_{10\text{Bit}}$	-2	0	+2	LSB	(9)
57	Continuous Offset Monitor Limit 10-bit output, before compensation	OFF_{MON}	-66	—	+66	LSB	(3)
58	Range of Output (10-bit Mode) Acceleration	RANGE	-480	—	+480	LSB	(3)
Cross-Axis Sensitivity							
59	Z-axis to X-axis	* V_{ZX}	-5	—	+5	%	(3)
60	Y-axis to X-axis	* V_{YX}	-5	—	+5	%	(3)
61	System Output Noise Peak (10-bit Mode, 1 Hz - 1 kHz, All Ranges)	* η_{Peak}	-4	—	+4	LSB	(3)
62	System Output Noise RMS (10-bit mode, 1 Hz - 1 kHz, All Ranges)	* η_{RMS}	—	—	+1.0	LSB	(3)
Non-linearity							
63	10-bit output, $\leq \pm 240\text{g}$	$\text{NL}_{\text{OUT}_{240\text{g}}}$	-2	—	+2	%	(3)
64	10-bit output, $> \pm 240\text{g}$	$\text{NL}_{\text{OUT}_{480\text{g}}}$	-2	—	+2	%	(3)

2.5 Electrical Characteristics - Self-Test and Overload

$V_L \leq (V_{CC} - V_{SS}) \leq V_H$, $T_L \leq T_A \leq T_H$, $\Delta T \leq 25$ K/min, unless otherwise specified.

#	Characteristic	Symbol	Min	Typ	Max	Units	
65	10-Bit Output During Active Self-Test ($T_L \leq T_A \leq T_H$) ±60g Range *	g_{ST10_60X}	120	—	280	LSB	(3)
66	±120g Range *	g_{ST10_120X}	40	—	160	LSB	(3)
67	±240g Range *	g_{ST10_240X}	56	—	184	LSB	(3)
68	±480g Range *	g_{ST10_480X}	8	—	112	LSB	(3)
69	Acceleration (without hitting internal g-cell stops) ±60g Range Positive/Negative	$g_{g-cell_Clip60X}$	400	456	500	g	(9)
70	Acceleration (without hitting internal g-cell stops) ±120g Range Positive/Negative	$g_{g-cell_Clip120X}$	400	456	500	g	(9)
71	Acceleration (without hitting internal g-cell stops) ±240g Range Positive/Negative	$g_{g-cell_Clip240X}$	1750	2065	2300	g	(9)
72	Acceleration (without hitting internal g-cell stops) ±480g Range Positive/Negative	$g_{g-cell_Clip480X}$	1750	2065	2300	g	(9)
73	$\Sigma\Delta$ and Sinc Filter Clipping Limit ±60g Range Positive/Negative	$g_{ADC_Clip60X}$	191	210	233	g	(9)
74	$\Sigma\Delta$ and Sinc Filter Clipping Limit ±120g Range Positive/Negative	$g_{ADC_Clip120X}$	353	380	410	g	(9)
75	$\Sigma\Delta$ and Sinc Filter Clipping Limit ±240g Range Positive/Negative	$g_{ADC_Clip240X}$	928	1055	1218	g	(9)
76	$\Sigma\Delta$ and Sinc Filter Clipping Limit ±480g Range Positive/Negative	$g_{ADC_Clip480X}$	1690	1879	2106	g	(9)

2.6 Dynamic Electrical Characteristics - PSI5

$V_L \leq (V_{CC} - V_{SS}) \leq V_H$, $T_L \leq T_A \leq T_H$, $\Delta T \leq 25$ K/min, unless otherwise specified

#	Characteristic	Symbol	Min	Typ	Max	Units	
77	Initialization Timing Phase 1	t_{PSI5_INIT1}	—	$532000 / f_{OSC}$	—	s	(7)
78	Phase 2 (10-Bit, Asynchronous Mode 0, k = 8)	$t_{PSI5_INIT2_10a0}$	—	$512 * t_{ASYNC}$	—	s	(7)
79	Phase 3 (10-Bit, Asynchronous Mode 0, ST_RPT = 0)	$t_{PSI5_INIT3_10a0}$	—	$19 * t_{ASYNC}$	—	s	(7, 12)
80	Offset Cancellation Stage 1 Operating Time	t_{OC1}	—	$320000 / f_{OSC}$	—	s	(7)
81	Offset Cancellation Stage 2 Operating Time	t_{OC2}	—	$280000 / f_{OSC}$	—	s	(7)
82	Self-Test Stage 1 Operating Time	t_{ST1}	—	$128000 / f_{OSC}$	—	s	(7)
83	Self-Test Stage 2 Operating Time	t_{ST2}	—	$128000 / f_{OSC}$	—	s	(7)
84	Self-Test Stage 3 Operating Time	t_{ST3}	—	$128000 / f_{OSC}$	—	s	(7)
85	Self-Test Repetitions	ST_RPT	0	—	5		(7, 12)
86	Programming Mode Entry Window	t_{PME}	—	$300000 / f_{OSC}$	—	s	(7)
87	Data Transmission Single Bit Time (PSI5 Low Bit Rate) *	t_{BIT_LOW}	7.6000	8.0000	8.4000	μ s	(7)
88	Modulation Current (20% to 80% of $I_{MOD} - I_{IDLE}$) Rise Time	t_{RISE}	324	463	602	ns	(3)
89	Position of bit transition (PSI5 Low Baud Rate) *	$t_{Bittrans_LowBaud}$	49	50	51	%	(7)
90	Asynchronous Response Time *	t_{ASYNC}	—	$912 / f_{OSC}$	—	s	(7)

2.7 Dynamic Electrical Characteristics - Signal Chain

$V_L \leq (V_{CC} - V_{SS}) \leq V_H$, $T_L \leq T_A \leq T_H$, $\Delta T \leq 25$ K/min, unless otherwise specified

#	Characteristic	Symbol	Min	Typ	Max	Units	
91	Internal Oscillator Frequency *	f_{OSC}	3.80	4	4.20	MHz	(1)
92	DSP Low-Pass Filter (Note15) Cutoff frequency LPF0 (referenced to 0 Hz)	f_{C_LPF0}	—	400	—	Hz	(7)
93	Filter Order LPF0 *	O_{LPF0}	—	3	—	1	(7)
94	DSP Offset Cancellation Low-Pass Filter (Note 15) Offset Cancellation Low-Pass Filter Input Sample Rate	$t_{OC_SampleRate}$	—	256	—	μ s	(7)
95	Stage 1 Cutoff frequency, Startup Phase 1	f_{C_OC10}	—	10.0	—	Hz	(7)
96	Stage 1 Filter Order, Startup Phase 1	O_{OC10}	—	1	—	1	(7)
97	Stage 2 Cutoff frequency, Startup Phase 1	f_{C_OC03}	—	0.300	—	Hz	(7)
98	Stage 2 Filter Order, Startup Phase 1	O_{OC03}	—	1	—	1	(7)
99	Cutoff frequency, Option 0	f_{C_OC0}	—	0.100	—	Hz	(7)
100	Filter Order, Option 0	O_{OC0}	—	1	—	1	(7)
101	Offset Cancellation Output Update Rate (10-Bit Mode)	$t_{offRate_10}$	—	$f_{OSC} / 2e6$	—	s	(7)
102	Offset Cancellation Output Step Size (10-Bit Mode)	OFF _{Step_10}	—	0.5	—	LSB	(7)
103	Offset Monitor Update Frequency	OFFMON _{OSC}	—	$f_{OSC} / 2000$	—	Hz	(7)
104	Offset Monitor Count Limit	OFFMON _{CNTLIMIT}	—	4096	—	1	(7)
105	Offset Monitor Counter Size	OFFMON _{CNTSIZE}	—	8192	—	1	(7)
106	Sensing Element Natural Frequency $\pm 60g$	f_{gcell_X60}	12651	—	13871	Hz	(9)
107	$\pm 120g$	f_{gcell_X120}	12651	—	13871	Hz	(9)
108	$\pm 240g$	f_{gcell_X240}	26000	—	28700	Hz	(9)
109	$\pm 480g$	f_{gcell_X480}	26000	—	28700	Hz	(9)
110	Sensing Element Rolloff Frequency (-3 db) $\pm 60g$	f_{gcell_X60}	938	—	2592	Hz	(9)
111	$\pm 120g$	f_{gcell_X120}	938	—	2592	Hz	(9)
112	$\pm 240g$	f_{gcell_X240}	3952	—	14370	Hz	(9)
113	$\pm 480g$	f_{gcell_X480}	3952	—	14370	Hz	(9)
114	Sensing Element Damping Ratio $\pm 60g$	ζ_{gcell_X60}	2.760	—	6.770	—	(9)
115	$\pm 120g$	ζ_{gcell_X120}	2.760	—	6.770	—	(9)
116	$\pm 240g$	ζ_{gcell_X240}	1.260	—	3.602	—	(9)
117	$\pm 480g$	ζ_{gcell_X480}	1.260	—	3.602	—	(9)
118	Sensing Element Delay (@100 Hz) $\pm 60g$	$f_{gcell_delay_X60}$	63	—	170	μ s	(9)
119	$\pm 120g$	$f_{gcell_delay_X120}$	63	—	170	μ s	(9)
120	$\pm 240g$	$f_{gcell_delay_X240}$	13	—	40	μ s	(9)
121	$\pm 480g$	$f_{gcell_delay_X480}$	13	—	40	μ s	(9)
122	Package Resonance Frequency	$f_{Package}$	100	—	—	kHz	(9)

2.8 Dynamic Electrical Characteristics - Supply and SPI

$V_L \leq (V_{CC} - V_{SS}) \leq V_H$, $T_L \leq T_A \leq T_H$, $\Delta T \leq 25$ K/min, unless otherwise specified

#	Characteristic	Symbol	Min	Typ	Max	Units	
123	Quiescent Current Settling Time (Power Applied to $I_q = I_{IDLE} \pm 2$ mA)	t_{SET}	—	—	5	ms	(3)
124	Reset Recovery Internal Delay (After internal POR)	t_{INT_INIT}	—	$16000 / f_{OSC}$	—	s	(7)
125	V_{CC} Micro-cut ($C_{BUF}=C_{REG}=C_{REGA}=1$ μ F)	$t_{VCC_MICROCUTmin}$ $t_{VCC_MICROCUT}$ t_{VCC_RESET}	30	—	—	μ s	(3)
126	Survival Time (V_{CC} disconnect without Reset, $C_{BUF}=C_{REG}=C_{REGA}=700$ nF)		50	—	—	μ s	(3)
127	Reset Time (V_{CC} disconnect above which Reset is guaranteed)		—	—	1000	μ s	(3)
128	V_{BUF} , Capacitor Monitor Disconnect Time (Figure 9)	$t_{POR_CAPTEST}$	—	$12000 / f_{OSC}$	—	s	(7)
129	POR to first Capacitor Test Disconnect Disconnect Delay, Asynchronous Mode (Figure 9)	$t_{CAPTEST_ADLY}$	—	$688 / f_{OSC}$	—	s	(7)
130	V_{REG} , V_{REGA} Capacitor Monitor	$t_{POR_CAPTEST}$ $t_{CAPTEST_RATE}$	—	$12000 / f_{OSC}$	—	s	(7)
131	POR to first Capacitor Test Disconnect Disconnect Rate		—	$256 / f_{OSC}$	—	s	(7)
132	Serial Interface Timing (See Figure 6, $C_{DOUT} \leq 80$ pF, $R_{DOUT} \geq 10$ k Ω)						
133	Clock (SCLK) period (10% of V_{CC} to 10% of V_{CC})	t_{SCLK}	320	—	—	ns	(9)
134	Clock (SCLK) high time (90% of V_{CC} to 90% of V_{CC})	t_{SCLKH}	120	—	—	ns	(9)
135	Clock (SCLK) low time (10% of V_{CC} to 10% of V_{CC})	t_{SCLKL}	120	—	—	ns	(9)
136	Clock (SCLK) rise time (10% of V_{CC} to 90% of V_{CC})	t_{SCLKR}	—	15	40	ns	(9)
137	Clock (SCLK) fall time (90% of V_{CC} to 10% of V_{CC})	t_{SCLKF}	—	15	28	ns	(9)
138	\overline{CS} asserted to SCLK high ($\overline{CS} = 10\%$ of V_{CC} to SCLK = 10% of V_{CC})	t_{LEAD}	60	—	—	ns	(9)
139	\overline{CS} asserted to D_{OUT} valid ($\overline{CS} = 10\%$ of V_{CC} to $D_{OUT} = 10/90\%$ of V_{CC})	t_{ACCESS}	—	—	60	ns	(9)
140	Data setup time ($D_{IN} = 10/90\%$ of V_{CC} to SCLK = 10% of V_{CC})	t_{SETUP}	20	—	—	ns	(9)
141	D_{IN} Data hold time (SCLK = 90% of V_{CC} to $D_{IN} = 10/90\%$ of V_{CC})	t_{HOLD_IN}	10	—	—	ns	(9)
142	D_{OUT} Data hold time (SCLK = 90% of V_{CC} to $D_{OUT} = 10/90\%$ of V_{CC})	t_{HOLD_OUT}	0	—	—	ns	(9)
143	SCLK low to data valid (SCLK = 10% of V_{CC} to $D_{OUT} = 10/90\%$ of V_{CC})	t_{VALID}	—	—	50	ns	(9)
144	SCLK low to \overline{CS} high (SCLK = 10% of V_{CC} to $\overline{CS} = 90\%$ of V_{CC})	t_{LAG}	60	—	—	ns	(9)
145	\overline{CS} high to D_{OUT} disable ($\overline{CS} = 90\%$ of V_{CC} to $D_{OUT} = Hi Z$)	$t_{DISABLE}$	—	—	60	ns	(9)
	\overline{CS} high to \overline{CS} low ($\overline{CS} = 90\%$ of V_{CC} to $\overline{CS} = 90\%$ of V_{CC})	t_{CSN}	1000	—	—	ns	(9)

- Parameters tested 100% at final test.
- Parameters tested 100% at wafer probe.
- Verified by characterization
- * Indicates critical characteristic.
- Verified by qualification testing.
- Parameters verified by pass/fail testing in production.
- Functionality guaranteed by modeling, simulation and/or design verification. Circuit integrity assured through IDDQ and scan testing. Timing is determined by internal system clock frequency.
- N/A.
- Verified by simulation.
- N/A.
- Measured at V_{CC} pin; V_{SYNC} guaranteed across full V_{IDLE} range.
- Self-Test repeats on failure up to a ST_RPT_{MAX} times before transmitting Sensor Error Message.
- N/A.
- Thermal resistance between the die junction and the exposed pad; cold plate is attached to the exposed pad.
- Filter cutoff frequencies are directly dependent upon the internal oscillator frequency.

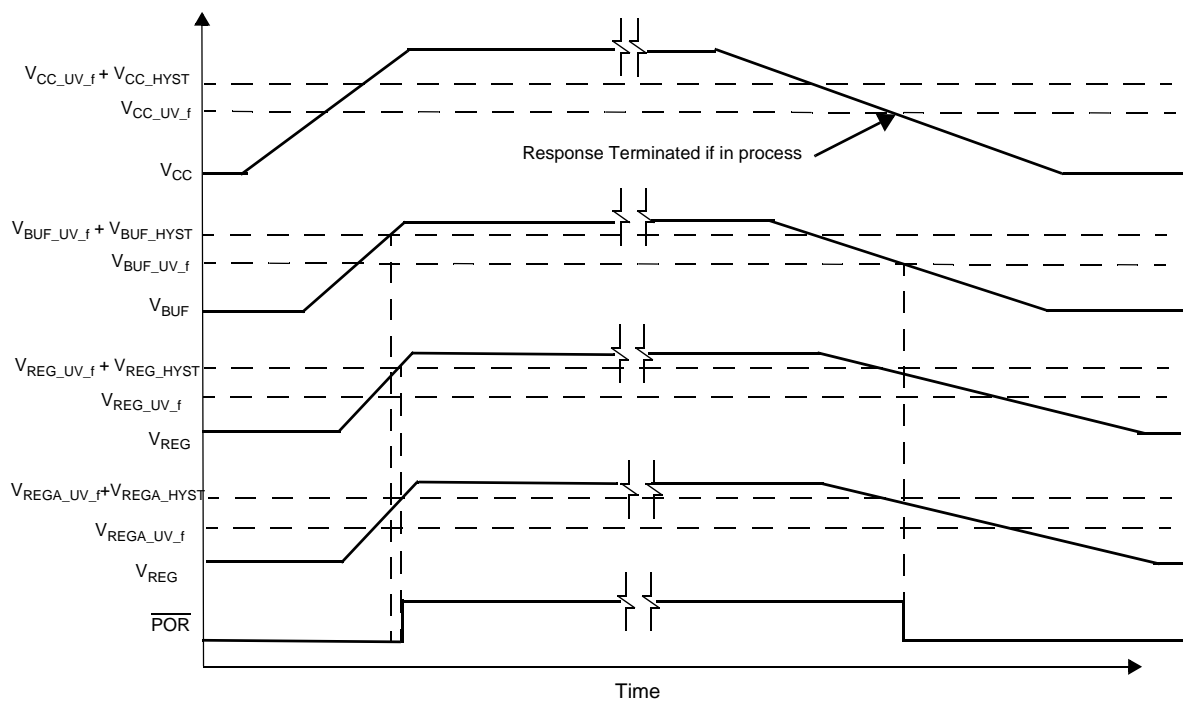

Figure 5. Powerup Timing

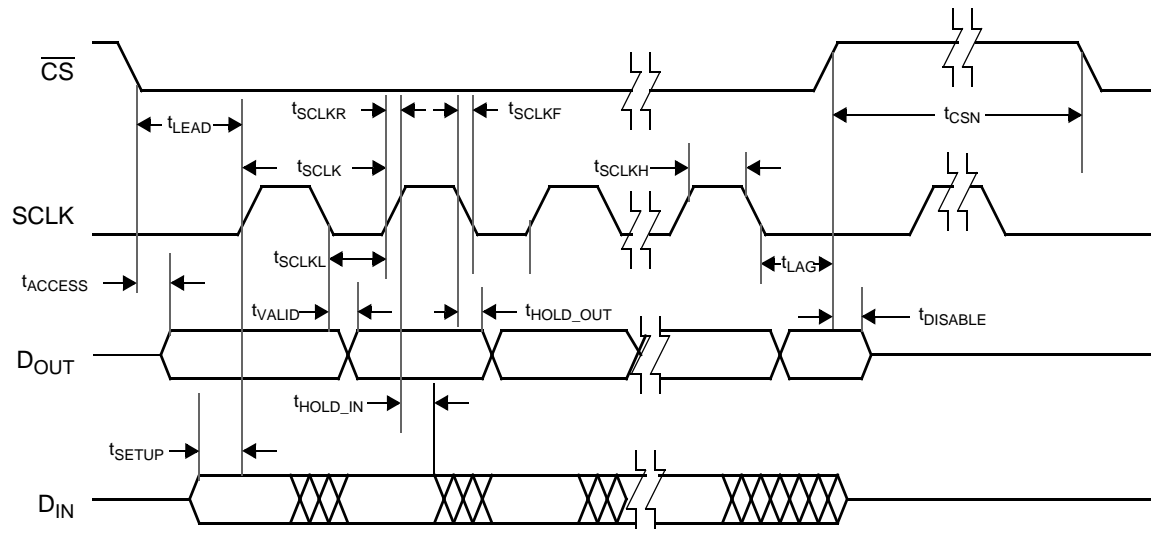

Figure 6. Serial Interface Timing

3 Functional Description

3.1 User Accessible Data Array

A user accessible data array allows for each device to be customized. The array consists of an OTP factory programmable block, an OTP user programmable block, and read-only registers for device status. The OTP blocks incorporate independent error detection circuitry for fault detection (reference [Section 3.2](#)). Portions of the factory programmable array are reserved for factory-programmed trim values. The user accessible data is shown in [Table 2](#).

Table 2. User Accessible Data

Byte Addr (XLong Msg)	Register	Nibble Addr (Long Msg)	Bit Function				Nibble Addr (Long Msg)	Bit Function				Type
			7	6	5	4		3	2	1	0	
\$00	SN0	\$01	SN[7]	SN[6]	SN[5]	SN[4]	\$00	SN[3]	SN[2]	SN[1]	SN[0]	R
\$01	SN1	\$03	SN[15]	SN[14]	SN[13]	SN[12]	\$02	SN[11]	SN[10]	SN[9]	SN[8]	
\$02	SN2	\$05	SN[23]	SN[22]	SN[21]	SN[20]	\$04	SN[19]	SN[18]	SN[17]	SN[16]	
\$03	SN3	\$07	SN[31]	SN[30]	SN[29]	SN[28]	\$06	SN[27]	SN[26]	SN[25]	SN[24]	
\$04	DEVCFG1	\$09	0	0	1	0	\$08	0	RNG[2]	RNG[1]	RNG[0]	
\$05	DEVCFG2	\$0B	0	0	0	0	\$0A	0	0	0	0	
\$06	DEVCFG3	\$0D	0	0	0	0	\$0C	0	0	0	0	
\$07	DEVCFG4	\$0F	0	0	0	0	\$0E	0	0	0	0	
\$08	DEVCFG5	\$11	0	0	0	0	\$10	0	0	0	0	
\$09	DEVCFG6	\$13	0	1	0	0	\$12	0	0	0	0	
\$0A	DEVCFG7	\$15	0	0	0	0	\$14	0	0	0	0	
\$0B	DEVCFG8	\$17	1	0	1	0	\$16	0	0	0	0	
\$0C	SC	\$19	0	TM_B	RESERVED	IDEN_B	\$18	OC_INIT_B	IDEF_B	OFF_B	0	
\$0D	MFG_ID	\$1B	0	0	0	0	\$1A	0	0	0	0	

Type codes

R: Readable register via PSI5

3.1.1 Device Serial Number Registers

A unique serial number is programmed into the serial number registers of each device during manufacturing. The serial number is composed of the following information:

Bit Range	Content
SN[12:0]	Serial Number
SN[31:13]	Lot Number

Serial numbers begin at 1 for all produced devices in each lot and are sequentially assigned. Lot numbers begin at 1 and are sequentially assigned. No lot will contain more devices than can be uniquely identified by the 13-bit serial number. Depending on lot size and quantities, all possible lot numbers and serial numbers may not be assigned.

The serial number registers are included in the factory programmed OTP CRC verification. Reference [Section 3.2](#) for details regarding the CRC verification. Beyond this, the contents of the serial number registers have no impact on device operation or performance, and are only used for traceability purposes.

3.1.2 Factory Configuration Register (DEVCFG1)

The factory configuration register is a factory programmed, read-only register which contains user specific device configuration information. The factory configuration register is included in the factory programmed OTP CRC verification.

Location		Bit							
Address	Register	7	6	5	4	3	2	1	0
\$04	DEVCFG1	0	0	1	0	0	RNG[2]	RNG[1]	RNG[0]
Factory Default		0	0	1	0	0	0	0	0

3.1.2.1 Range Indication Bits (RNG[2:0])

The range indication bits are factory programmed and indicate the full-scale range of the device as shown below.

RNG[2]	RNG[1]	RNG[0]	Full-Scale Acceleration Range	g-Cell Design	PSI5 Init Data Transmission (D9) Reference Table 9
0	0	0	Reserved	N/A	0001
0	0	1	±60g	Medium-g	0111
0	1	0	Reserved	N/A	0010
0	1	1	±120 g	Medium-g	1000
1	0	0	Reserved	N/A	0011
1	0	1	±240 g	High-g	1001
1	1	0	Reserved	N/A	0100
1	1	1	±480 g	High-g	1010

3.1.3 Status Check Register (SC)

The status check register is a read-only register containing device status information.

Location		Bit							
Address	Register	7	6	5	4	3	2	1	0
\$0C	SC	0	TM_B	RESERVED	IDEN_B	OC_INIT_B	IDEF_B	OFF_B	0

3.1.3.1 Test Mode Flag (TM_B)

The test mode bit is cleared if the device is in test mode.

TM_B	Operating Mode
0	Test Mode is active
1	Test Mode is not active

3.1.3.2 Internal Data Error Flag (IDEN_B)

The internal data error bit is cleared if a register data error detection mismatch is detected in the user accessible OTP array. A device reset is required to clear the error.

IDEN_B	Error Condition
0	Error detection mismatch in user programmable OTP array
1	No error detected

3.1.3.3 Offset Cancellation Init Status Flag (OC_INIT_B)

The offset cancellation initialization status bit is set once the offset cancellation initialization process is complete, and the filter has switched to normal mode.

OC_INIT_B	Error Condition
0	Offset Cancellation in initialization
1	Offset Cancellation initialization complete (t_{OC1} and t_{OC2} expired)

3.1.3.4 Internal Factory Data Error Flag (IDEF_B)

The internal factory data error bit is cleared if a register data CRC fault is detected in the factory programmable OTP array. A device reset is required to clear the error.

IDEF_B	Error Condition
0	CRC error in factory programmable OTP array
1	No error detected

3.1.3.5 Offset Error Flag (OFF_B)

The offset error flag is cleared if the acceleration signal reaches the offset limit.

OFF_B	Error Condition
0	Offset error detected
1	No error detected

3.2 OTP Array Error Detection

The Factory programmed OTP array is verified for errors with a 3-bit CRC. The CRC verification is enabled only when the factory programmed array is locked. The CRC verification uses a generator polynomial of $g(x) = X^3 + X + 1$, with a seed value = '111'.

The CRC is continuously calculated on the factory programmable array with the exception of the factory lock bits. Bits are fed in from right to left (LSB first), and top to bottom (lower addresses first) in the register map. The calculated CRC is then compared against the stored 3 bit CRC. If a CRC error is detected in the OTP array, the IDEF_B bit is cleared in the SC register.

The CRC verification is completed on the memory registers which hold a copy of the fuse array values, not the fuse array values.

3.3 Voltage Regulators

The device derives its internal supply voltage from the V_{CC} and V_{SS} pins. Separate internal voltage regulators are used for the analog (V_{REGA}) and digital circuitry (V_{REG}). The analog and digital regulators are supplied by a buffer regulator (V_{BUF}) to provide immunity from EMC and supply dropouts on V_{CC} . External filter capacitors are required, as shown in Figure 1.

The voltage regulator module includes voltage monitoring circuitry which holds the device in reset following power-on until the internal voltages have increased above the undervoltage detection thresholds. The voltage monitor asserts internal reset when the external supply or internally regulated voltages fall below the undervoltage detection thresholds. A reference generator provides a reference voltage for the $\Sigma\Delta$ converter.

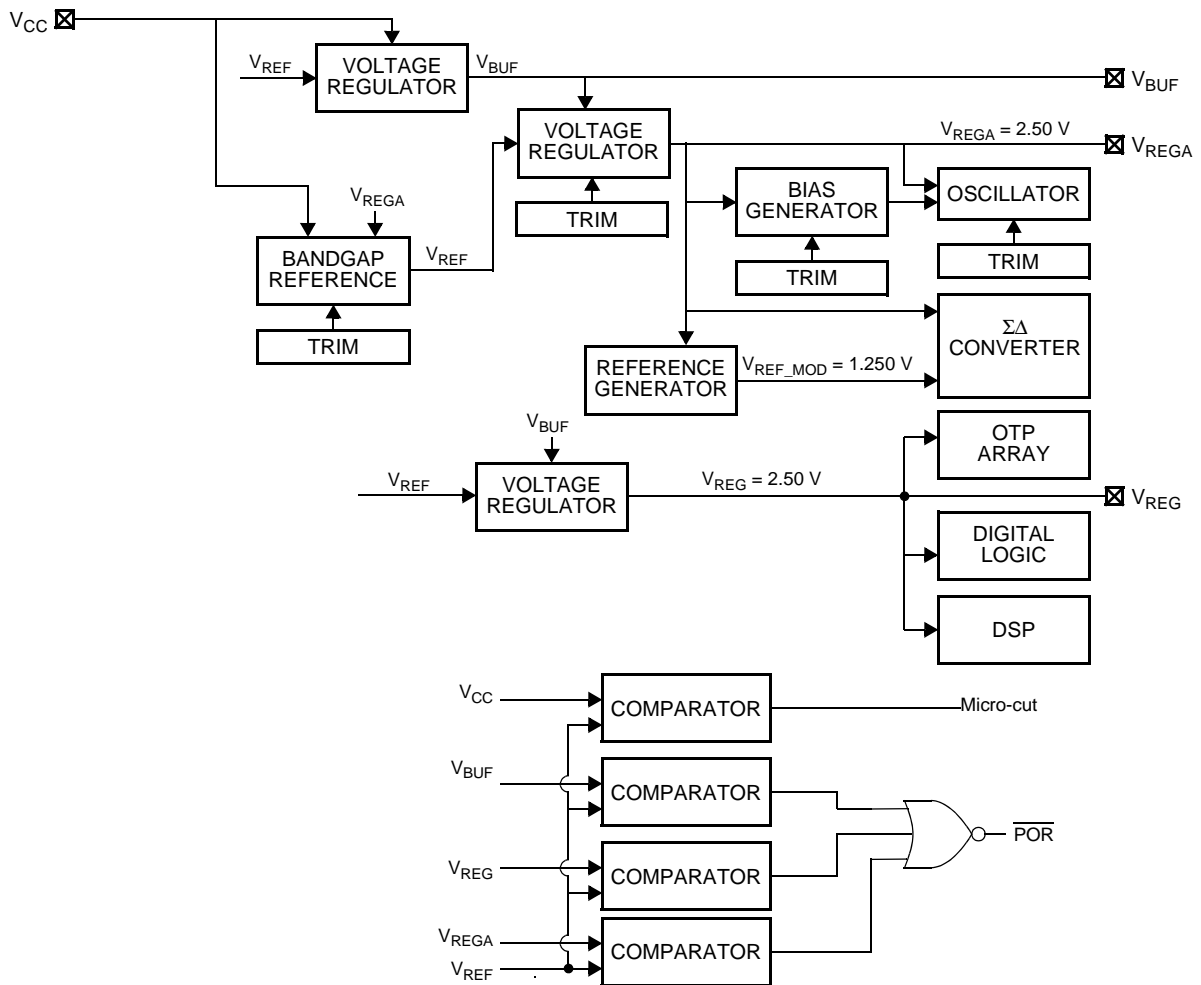

Figure 7. Voltage Regulation and Monitoring

3.3.1 V_{BUF} , V_{REG} and V_{REGA} Regulator Capacitor

The internal regulators require an external capacitor between each of the regulator pins (V_{BUF} , V_{REG} , or V_{REGA}) and the associated the V_{SS} / V_{SSA} pin for stability. [Figure 1](#) shows the recommended types and values for each of these capacitors.

3.3.2 V_{CC} , V_{BUF} , V_{REG} and V_{REGA} Undervoltage Monitor

A circuit is incorporated to monitor the supply voltage (V_{CC}) and all internally regulated voltages (V_{BUF} , V_{REG} and V_{REGA}). If any of internal regulator voltages fall below the specified undervoltage thresholds in [Section 2](#), the device will be reset. If V_{CC} falls below the specified threshold, PSI5 transmissions are terminated for the present response. Once the supply returns above the threshold, the device will respond to the next detected sync pulse. Reference [Figure 8](#).

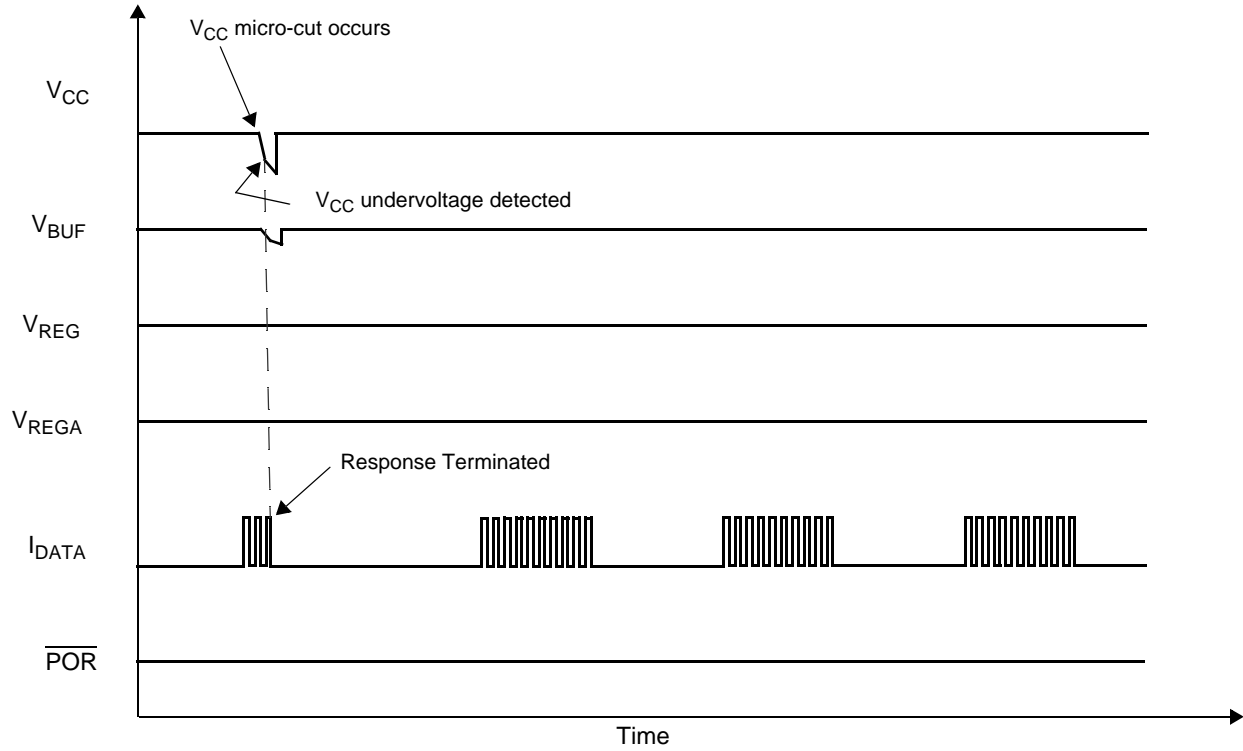

Figure 8. V_{CC} Micro-Cut Response

3.3.3 V_{BUF} , V_{REG} , and V_{REGA} Capacitance Monitor

A monitor circuit is incorporated to ensure predictable operation if the connection to the external V_{BUF} , V_{REG} , or V_{REGA} , capacitor becomes open.

The V_{BUF} regulator is disabled $t_{CAPTEST_ADLY}$ seconds after each data transmission for a duration of $t_{CAPTEST_TIME}$ seconds. If the external capacitor is not present, the regulator voltage will fall below the internal reset threshold, forcing a device reset.

The V_{REG} and V_{REGA} regulators are disabled at a continuous rate ($t_{CAPTEST_RATE}$), for a duration of $t_{CAPTEST_TIME}$ seconds. If either external capacitor is not present, the associated regulator voltage will fall below the internal reset threshold, forcing a device reset.

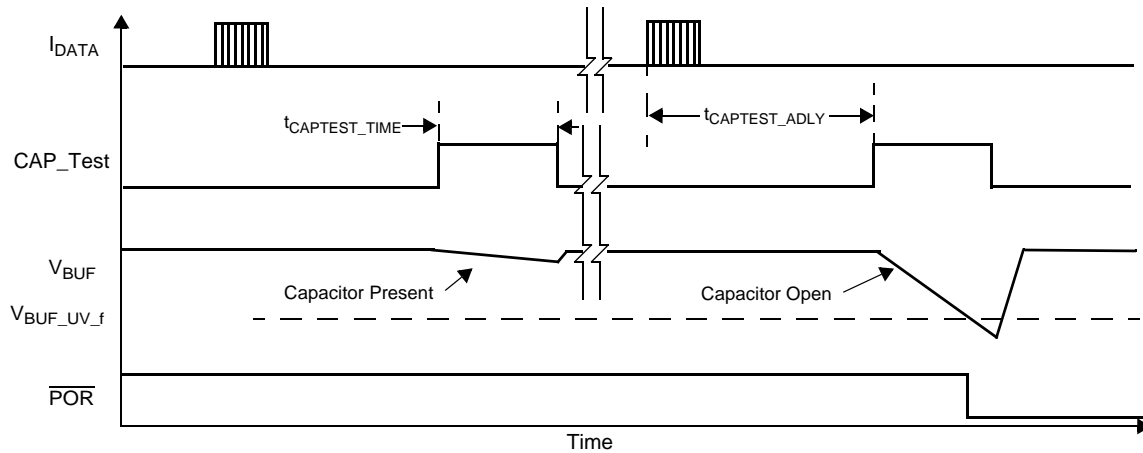

Figure 9. V_{BUF} Capacitor Monitor - Asynchronous Mode

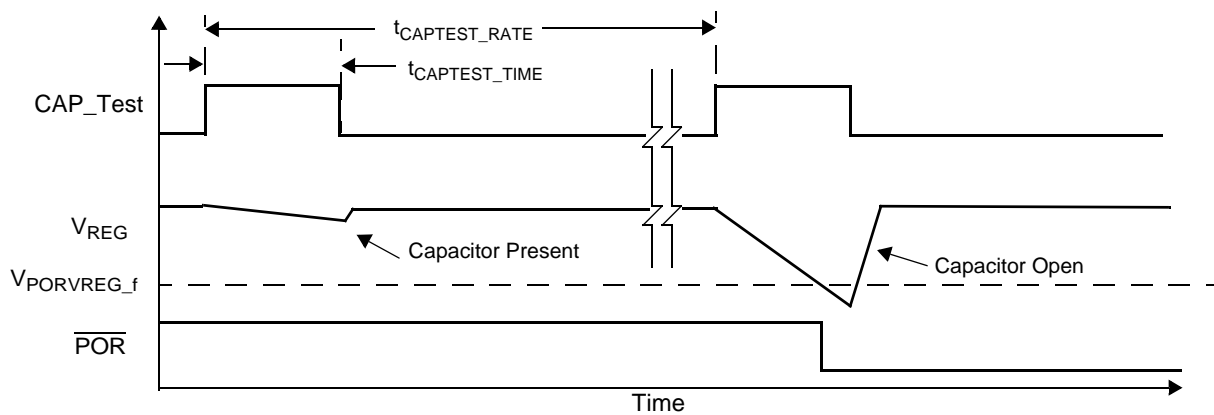

Figure 10. V_{REG} Capacitor Monitor

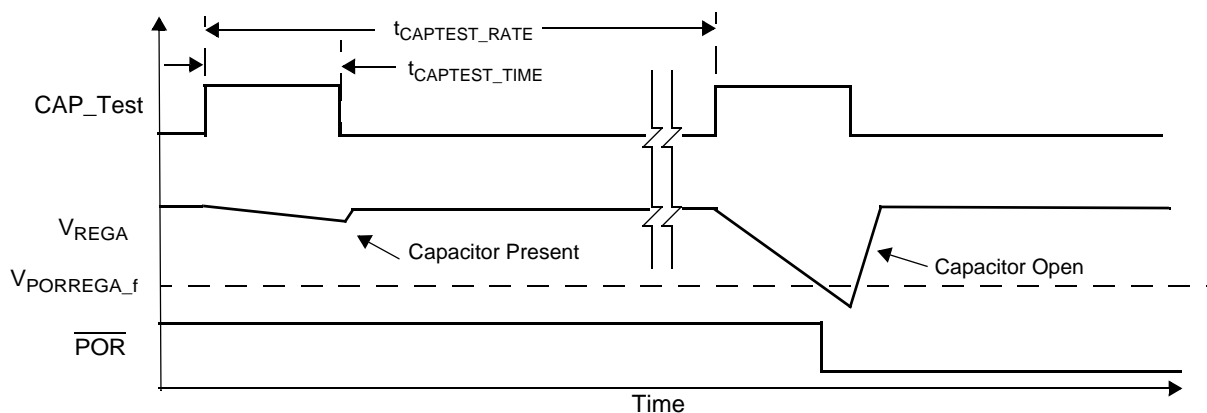

Figure 11. VREGA Capacitor Monitor

3.4 Internal Oscillator

A factory trimmed oscillator is included as specified in [Section 2](#).

3.5 Acceleration Signal Path

3.5.1 Transducer

The transducer is an overdamped mass-spring-damper system defined by the following transfer function:

where:

$$H(s) = \frac{\omega_n^2}{s^2 + 2 \cdot \zeta \cdot \omega_n \cdot s + \omega_n^2}$$

ζ = Damping Ratio

ω_n = Natural Frequency = $2 \cdot \Pi \cdot f_n$

Reference [Section 2.7](#) for transducer parameters.

3.5.2 $\Sigma\Delta$ Converter

A sigma delta modulator converts the differential capacitance of the transducer to a 1 MHz data stream that is input to the DSP block.

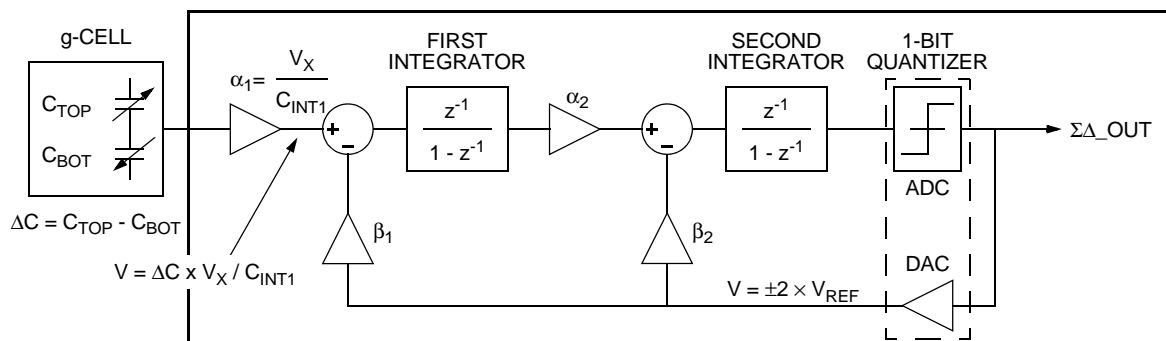

Figure 12. $\Sigma\Delta$ Converter Block Diagram

3.5.3 Digital Signal Processing Block

A Digital Signal Processing (DSP) block is used to perform signal filtering and compensation. A diagram illustrating the signal processing flow within the DSP block is shown in [Figure 13](#).

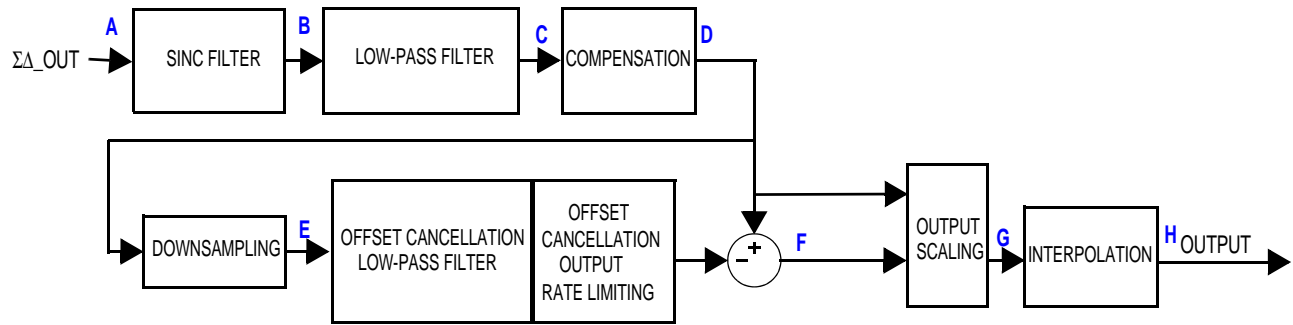

Figure 13. Signal Chain Diagram

Table 3. Signal Chain Characteristics

	Description	Sample Time (μs)	Data Width (Bits)	Over Range (Bits)	Signal Width (Bits)	Signal Noise (Bits)	Signal Margin (Bits)	Typical Block Latency	Reference
A	SD	1	1		1			203/f _{osc}	Section 3.5.2
B	SINC Filter	16	20		13				Section 3.5.3.2
C	Low-Pass Filter	16	26	4	10	3	9	Reference Section 3.5.3.2	Section 3.5.3.2
D	Compensation	16	26	4	10	3	9	68/f _{osc}	
E	Down Sampling	16	26	4	10	3	9		
F	High-Pass Filter	16	26	4	10	3	9	Reference Section 3.5.3.3	Section 3.5.3.3
G	DSP Sampling	16			10			4/f _{osc}	Section 3.5.3.5
	10-Bit Output Scaling								
H	Interpolation	1			10			64/f _{osc}	Section 3.5.3.5

3.5.3.1 Decimation Sinc Filter

The serial data stream produced by the ΣΔ converter is decimated and converted to parallel values by a 3rd order 16:1 sinc filter with a decimation factor of 16.

$$H(z) = \left[\frac{1 - z^{-16}}{16 \times (1 - z^{-1})} \right]^3$$

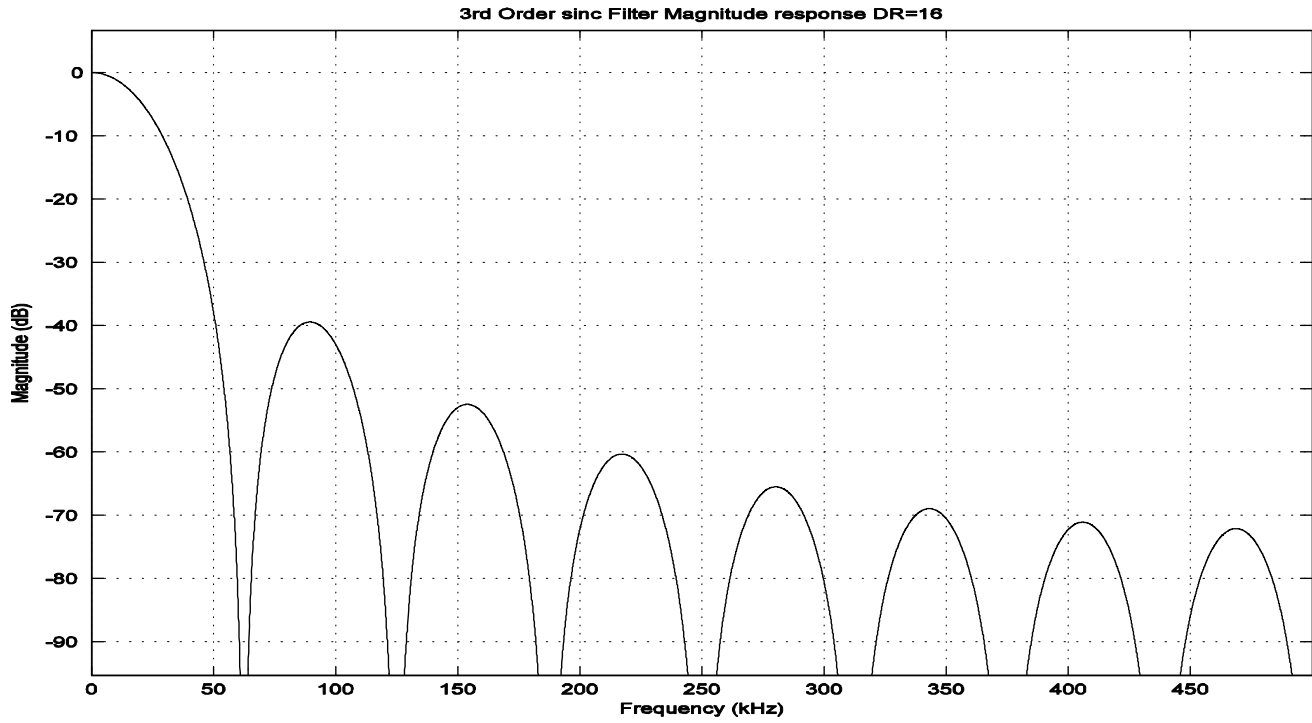

Figure 14. Sinc Filter Response, $t_s = 16 \mu s$

3.5.3.2 Low-Pass Filter

Data from the Sinc filter is processed by an infinite impulse response (IIR) low-pass filter.

$$H(z) = a_0 \cdot \frac{(n_{11} \cdot z^0) + (n_{12} \cdot z^{-1}) + (n_{13} \cdot z^{-2})}{(d_{11} \cdot z^0) + (d_{12} \cdot z^{-1}) + (d_{13} \cdot z^{-2})} \cdot \frac{(n_{21} \cdot z^0) + (n_{22} \cdot z^{-1}) + (n_{23} \cdot z^{-2})}{(d_{11} \cdot z^0) + (d_{22} \cdot z^{-1}) + (d_{23} \cdot z^{-2})}$$

Table 4. Low-Pass Filter Coefficients

Description	Filter Coefficients				Group Delay
400 Hz, 3-Pole LPF	a ₀	5.189235225042199e-02			2816/f _{osc}
	n ₁₁	1.629077582099646e-03	d ₁₁	1.0	
	n ₁₂	1.630351547919014e-03	d ₁₂	-9.481076477495780e-01	
	n ₁₃	0	d ₁₃	0	
	n ₂₁	2.500977520825902e-01	d ₂₁	1.0	
	n ₂₂	4.999999235890745e-01	d ₂₂	-1.915847097557409e+00	
	n ₂₃	2.499023243303036e-01	d ₂₃	9.191065266874253e-01	

Note: Low-Pass Filter values do not include g-cell frequency response.

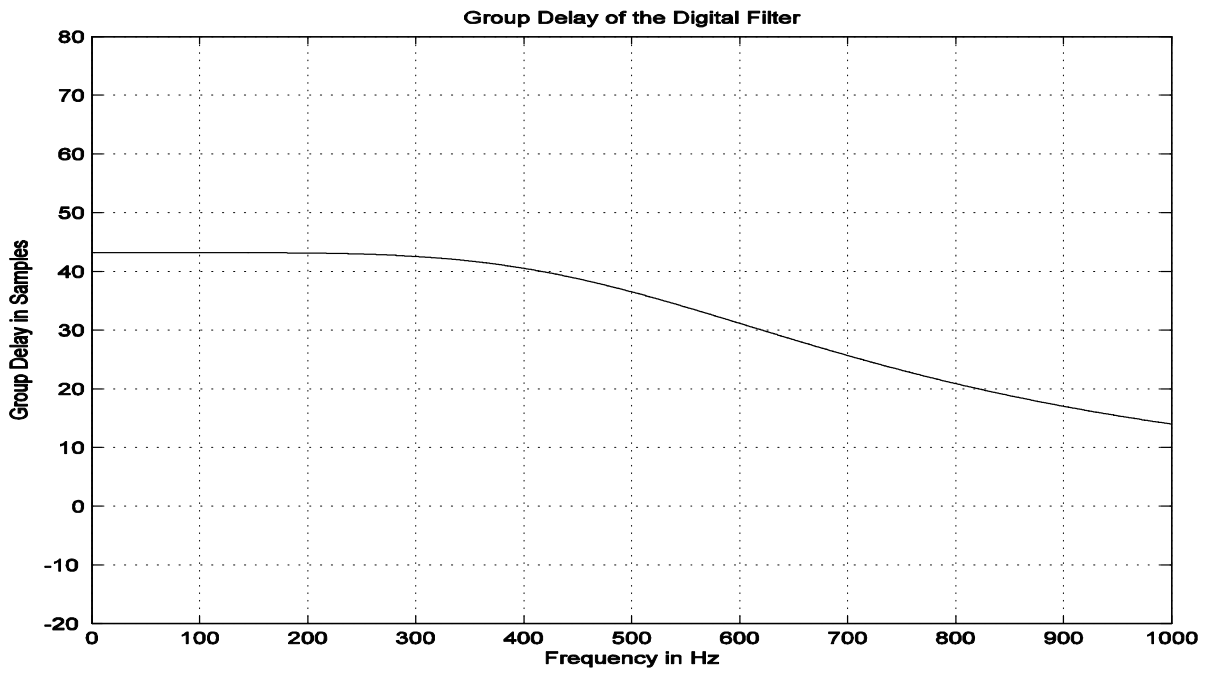
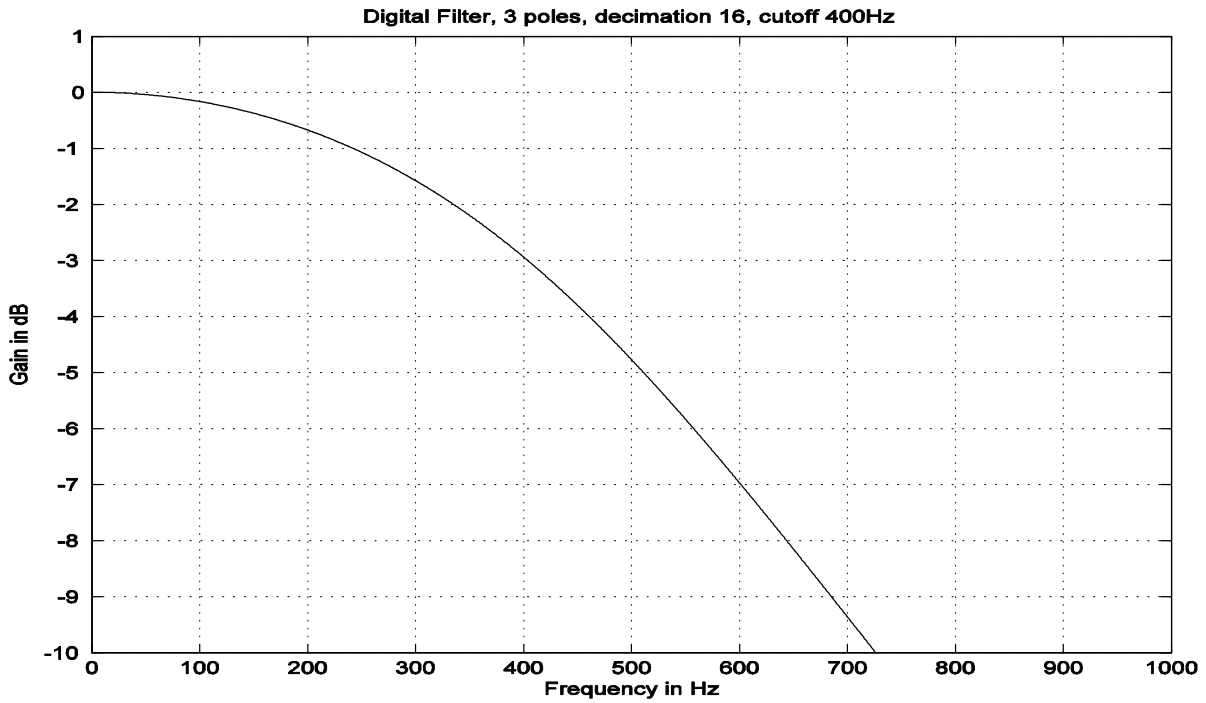

Figure 15. Low-Pass Filter Characteristics: $f_c = 400$ Hz, 3-Pole, $t_s = 16 \mu s$

3.5.3.3 Offset Cancellation

The device provides an offset cancellation circuit to remove internal offset error. A block diagram of the offset cancellation is shown in Figure 16.

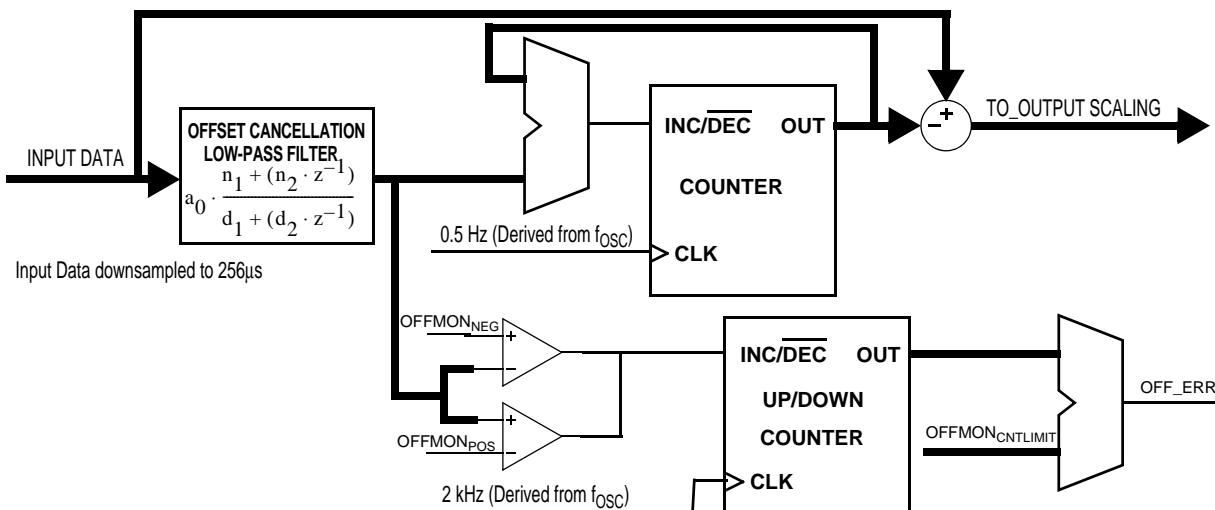

Figure 16. Offset Cancellation Block Diagram

The transfer function for the offset LPF is:

$$H(z) = a_0 \cdot \frac{n_1 + (n_2 \cdot z^{-1})}{d_1 + (d_2 \cdot z^{-1})}$$

Response parameters are specified in Section 2 and the offset LPF coefficients are specified in Table 6.

During startup, two phases of the offset LPF are used to allow for fast convergence of the internal offset error during initialization. The timing and characteristics of each phase are shown in Table 5 and Table 6 and specified in Section 2. For more information regarding the startup timing, reference the PSi5 initialization information in Section 4.4. The offset low-pass filter used in normal operation is selected by the OC_FILT bit as shown in Table 5.

During the Initialization Self-Test phase, the offset cancellation circuit output value is frozen.

During normal operation, output rate limiting is applied to the output of the high-pass filter. Rate limiting updates the offset cancellation output by OFF_Step_xx LSB every tOffRate_xx seconds.

Table 5. Offset Cancellation Startup Characteristics and Timing

Offset Cancellation Startup Phase	Offset LPF	Output Rate Limiting	Total Time for Phase
1	10 Hz	Bypassed	80 ms
2	0.3 Hz	Bypassed	70 ms
Self-Test	0.3 Hz	Bypassed (Frozen during ST2)	96 ms per Self-Test Sequence (up to 6 repeats)
Complete	0.1 Hz	Enabled	N/A

Table 6. High-Pass Filter Coefficients

Description	Coefficients				Group Delay
10 Hz HPF	ao ₀	0.015956938266754			16.384 ms
	no ₁	0.499998132328277	do ₁	1.0	
	no ₂	0.499998132328277	do ₂	-0.984043061733246	
0.3 Hz HPF	ao ₀	0.000482380390167			537.6 ms
	no ₁	0.499938218213271	do ₁	1.0	
	no ₂	0.499938218213271	do ₂	-0.999517619609833	
0.1 Hz HPF	ao ₀	0.0001608133316040			1591ms
	no ₁	0.4999999403953552	do ₁	1.0	
	no ₂	0.4999999403953552	do ₂	-0.9998391270637512	

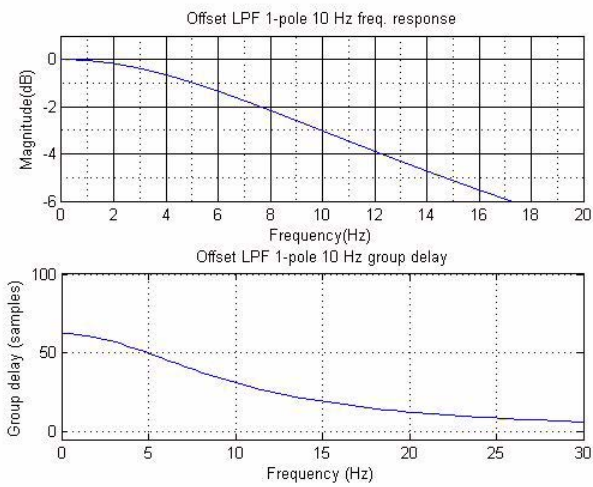

Figure 17. 10 Hz Offset Cancellation Low-Pass Filter Characteristics

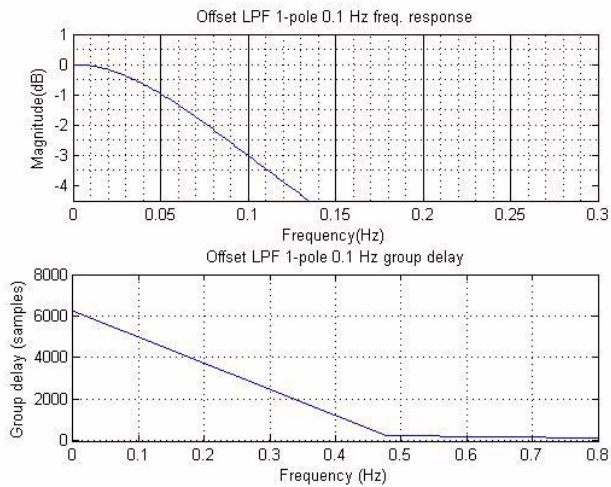

Figure 18. 0.1 Hz Offset Cancellation Low-Pass Filter Characteristics

3.5.3.4 Offset Monitor

The device includes an offset monitor circuit. The output of the single pole low-pass filter in the offset cancellation block is continuously monitored against the offset limits specified in [Section 2.4](#). An up/down counter is employed to count up if the output exceeds the limits, and to count down if the output is within the limits. The output of the counter is compared against the count limit $OFFMON_{CNTLIMIT}$. If the counter exceeds the limit, the OFF_B flag in the SC register is cleared. The counter rails once the max counter value is reached ($OFFMON_{CNTSIZE}$). The offset monitor is disabled during Initialization Phase 1, Phase 2, and Phase 3.

3.5.3.5 Data Interpolation

The device includes 16 to 1 linear data interpolation to minimize the system sample jitter. Each result produced by the digital signal processing chain is delayed one sample time.

3.5.3.6 Output Scaling

The 26-bit digital output from the DSP is clipped and scaled to a 10-bit word which spans the acceleration range of the device. [Figure 19](#) shows the method used to establish the output acceleration data word from the 26-bit DSP output.

Over Range			Signal										Noise				Margin				
D25	D24	D23	D22	D21	D20	D19	D18	D17	D16	D15	D14	D13	D12	D11	D10	D9	D8	...	D2	D1	D0
10-bit Data Word				D21	D20	D19	D18	D17	D16	D15	D14	D13	D12	Using Rounding							

Figure 19. 10-Bit Output Scaling Diagram

3.6 Overload Response

3.6.1 Overload Performance

The device is designed to operate within a specified range. Acceleration beyond that range (overload) impacts the output of the sensor. Acceleration beyond the range of the device can generate a DC shift at the output of the device that is dependent upon the overload frequency and amplitude. The g-cell is overdamped, providing the optimal design for overload performance. However, the performance of the device during an overload condition is affected by many other parameters, including:

- g-cell damping
- Non-linearity
- Clipping limits
- Symmetry

Figure 20 shows the g-cell, ADC and output clipping of the device over frequency. The relevant parameters are specified in Section 2.

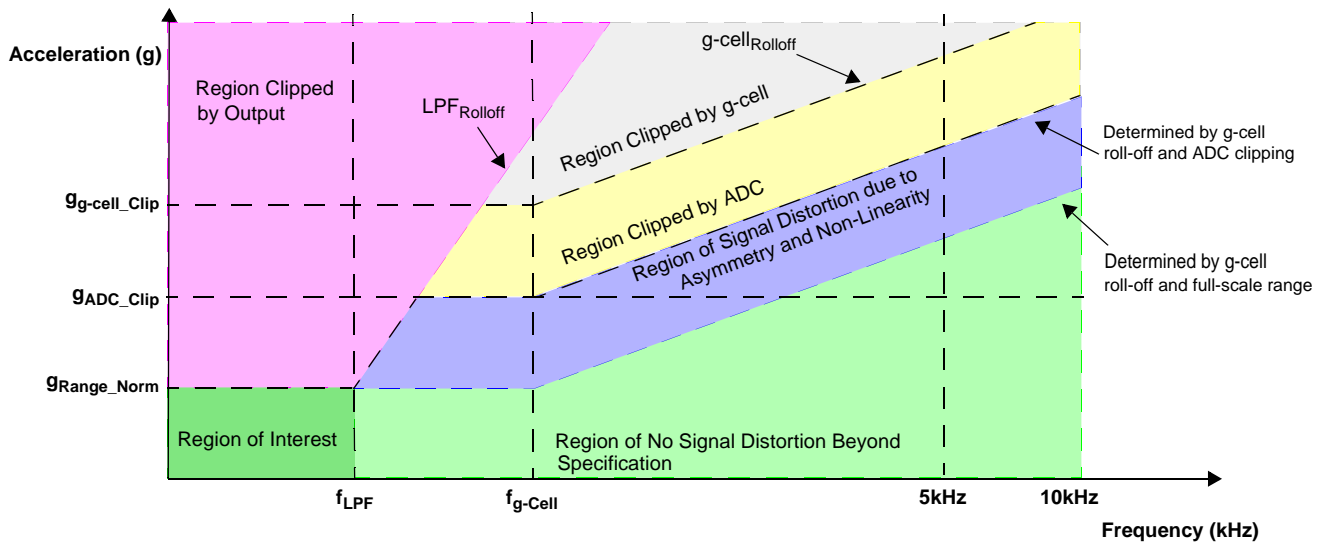

Figure 20. Output Clipping vs. Frequency

3.6.2 Sigma Delta Modulator Over Range Response

Over Range conditions exist when the signal level is beyond the full-scale range of the device but within the computational limits of the DSP. The $\Sigma\Delta$ converter can saturate at levels above those specified in Section 2 (G_{ADC_CLIP}). The DSP operates predictably under all cases of over range, although the signal may include residual high frequency components for some time after returning to the normal range of operation due to non-linear effects of the sensor.

4 PSI5 Layer and Protocol

4.1 Communication Interface Overview

The communication interface between a master device and the MMA52xx is established via a PSI5 compatible 2-wire interface. Figure 21 shows the PSI5 master to slave connections.

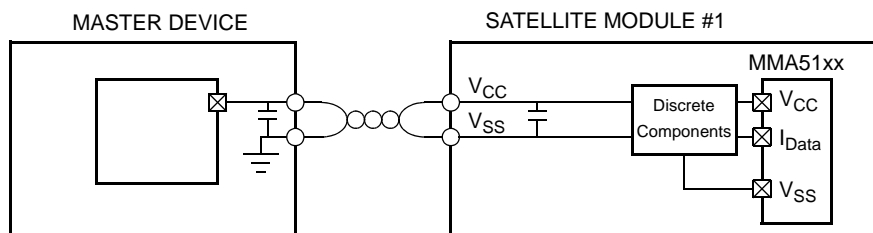

Figure 21. PSI5 Satellite Interface Diagram

4.2 Data Transmission Physical Layer

The device uses a two wire interface for both its power supply (V_{CC}), and data transmission. Data transmissions from the device to the PSI5 master are accomplished via modulation of the current on the power supply line.

4.3 Data Transmission Data Link Layer

4.3.1 Bit Encoding

The device outputs data by modulation of the V_{CC} current using Manchester 2 Encoding. Data is stored in a transition occurring in the middle of the bit time. The signal idles at the normal quiescent supply current. A logic low is defined as an increase in current at the middle of a bit time. A logic high is defined as a decrease in current at the middle of a bit time. There is always a transition in the middle of the bit time. If consecutive "1" or "0" data are transmitted, There will also be a transition at the start of a bit time.

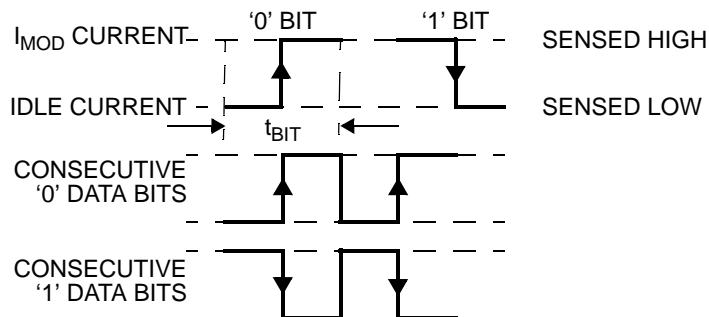

Figure 22. Manchester 2 Data Bit Encoding

4.3.2 Data Transmission

Transmission frames are composed of two start bits, a 10-bit data word, and error detection bit(s). Data words are transmitted least-significant bit (LSB) first. A typical Manchester-encoded transmission frame is illustrated in Figure 23.

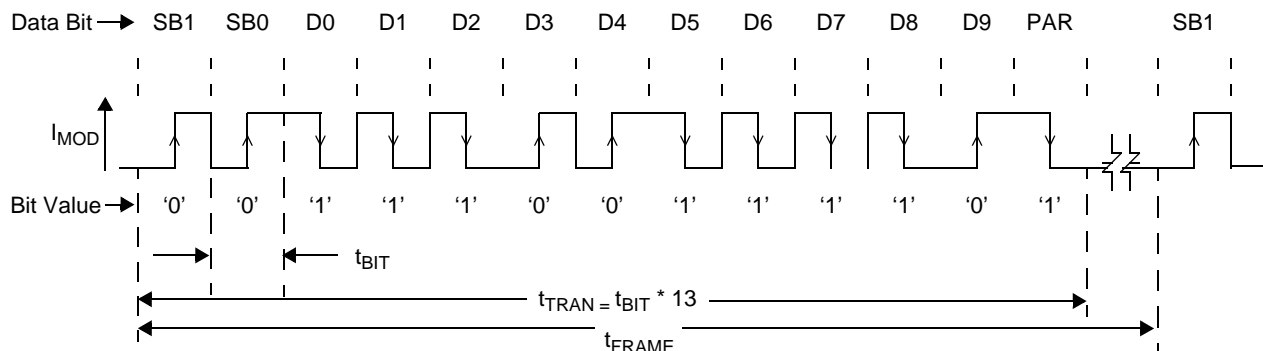

Figure 23. Example Manchester Encoded Data Transfer - PSI5-x10P

4.3.3 Error Detection

Error detection of the transmitted data is accomplished via a parity bit. Even parity is employed. The number of logic "1" bits in the transmitted message must be an even number.

4.3.4 Data Range Values

Table 8 shows the details for each data range.

Table 7. PS15 Data Values

10-Bit Data Value		Description
Decimal	Hex	
+511	\$1FF	Reserved
•	•	
•	•	
•	•	
+502	\$1F6	Sensor Defect Error Message
+501	\$1F5	
+500	\$1F4	Reserved
+499	\$1F3	
•	•	
•	•	
+489	\$1E9	Sensor Busy
+488	\$1E8	Sensor Ready
+487	\$1E7	Sensor Ready, but Unlocked
+486	\$1E6	Reserved
+485	\$1E5	
•	•	
•	•	
+481	\$1E1	Maximum positive acceleration value
+480	\$1E0	Positive acceleration values
•	•	
•	•	
•	•	
+3	\$03	
+2	\$02	0g level
+1	\$01	
0	0	
-1	\$3FF	Negative acceleration values
-2	\$3FE	
-3	\$3FD	
•	•	Maximum negative acceleration value
•	•	
-480	\$220	Initialization Data Codes 10-Bit Status Data Nibble 1 - 16 (0000 - 1111) (Dx)
-481	\$21F	
•	•	
-496	\$210	Initialization Data IDs Block ID 1 - 16 (10-bit Mode) (IDx)
-497	\$20F	
•	•	
•	•	
-512	\$200	

4.4 Initialization

Following powerup, the device proceeds through an initialization process which is divided into 3 phases:

- Initialization Phase 1: No Data transmissions occur
- Initialization Phase 2: Sensor self-test and transmission of configuration information
- Initialization Phase 3: Transmission of “Sensor Busy”, and “Sensor Ready” / “Sensor Defect” message

Once initialization is completed the device begins normal mode operation, which continues as long as the supply voltage remains within the specified limits.

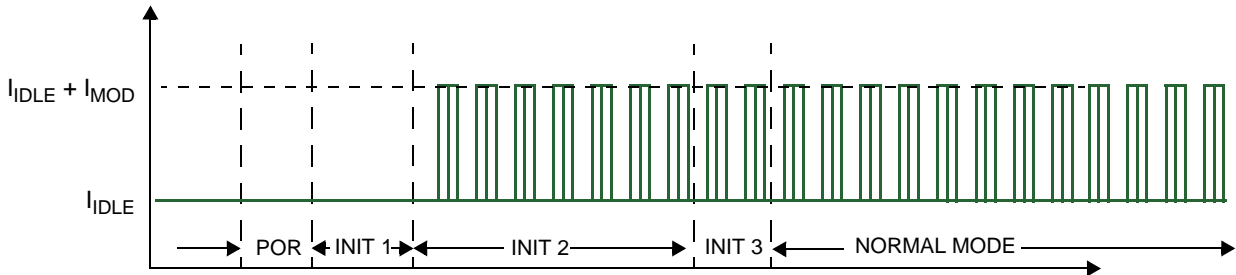

Figure 24. PSI5 Sensor 10-Bit Initialization

During PSI5 initialization, the device completes an internal initialization process consisting of the following:

- Power-on Reset
- Device Initialization
- Program Mode Entry Verification
- Offset Cancellation Initialization (2 Stages)
- Self-Test

Figure 25 shows the timing for internal and external initialization.

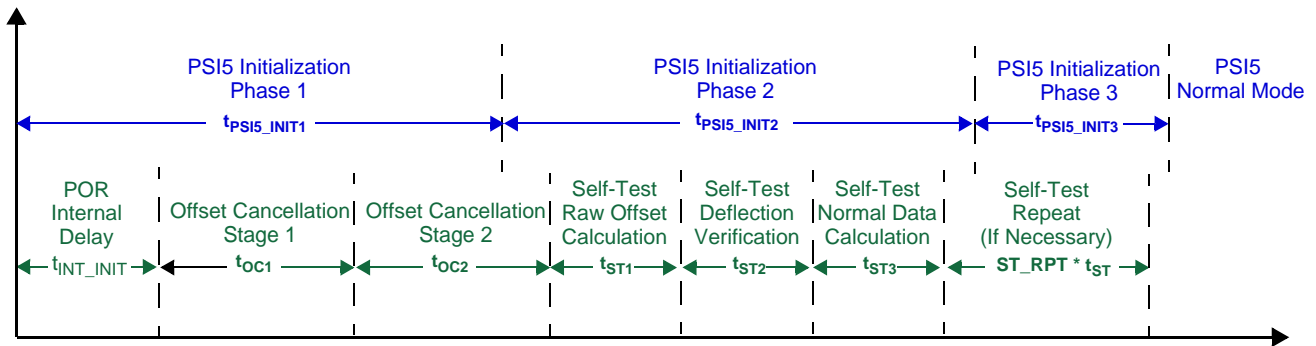

Figure 25. Initialization Timing

4.4.1 PSI5 Initialization Phase 1

During PSI5 initialization phase 1, the device begins internal initialization and self checks, but transmits no data. Initialization begins with the sequence below and shown in [Figure 25](#):

- Internal Delay to ensure analog circuitry has stabilized (t_{INT_INIT})
- Offset Cancellation phase 1 Initialization (t_{OC1})
- Offset Cancellation phase 2 Initialization (t_{OC2})

4.4.2 PSI5 Initialization Phase 2

During PSI5 initialization phase 2, the device continues its internal self checks and transmits the PSI5 initialization phase 2 data. Initialization is transmitted using the initialization data codes and IDs specified in [Table 9](#), and in the order shown in [Figure 26](#).

D1						D2						...	D32								
ID1 ₁	D1 ₁	ID1 ₂	D1 ₂	...	ID1 _k	D1 _k	ID2 ₁	D2 ₁	ID2 ₂	D2 ₂	...	ID2 _k	D2 _k	...	ID32 ₁	D32 ₁	ID32 ₂	D32 ₂	...	ID32 _k	D32 _k
Repeat k times						Repeat k times						...	Repeat k times								

Figure 26. PSI5 Initialization Phase 2 Data Transmission Order (10-bit Mode)

The Initialization phase 2 time is calculated with the following equation:

$$t_{PHASE2} = TRANS_{NIBBLE} \times k \times (\text{DataFields}) \times t_{ASYNC}$$

where:

- $TRANS_{NIBBLE}$ = # of Transmissions per Data Nibble
2 for 10-bit Data: 1 for ID, and 1 for Data
- k = the repetition rate for the data fields
- Data Fields = 32 data fields for 10-bit data
- t_{S-S} = Sync Pulse Period

4.4.2.1 PSi5 Initialization Phase 2

In PSi5 initialization phase 2, 10-bit mode, the device transmits a sequence of sensor specific configuration and serial number information. The transmission data is in conformance with the PSi5 specification, Revision 1.3, Revision 1.10. The data content and transmission format is shown in [Table 8](#) and [Table 9](#). Times are calculated using the equation in [Section 4.4.2](#).

Table 8. Initialization Phase 2 Time

Operating Mode	Repetition Rate (k)	# of Transmissions	Nominal Phase 2 Time
Asynchronous Mode (228 μs)	8	512	116.7 ms

Table 9. PSi5 Initialization Phase 2 Data

PSi5 V1.2 Field ID #	PSi5 V1.2 Nibble ID #	Page Address	PSi5 Nibble Address	Register Address	Description	Value	
F1	D1	0	0000	Hard-coded	Protocol Revision = V1.3	0100	
F2	D2, D3		0001, 0010	Hard-coded	Number of Data Blocks = 32	0010 0000	
F3	D4, D5		0100, 0110	MFG_ID[7:0]	Manufacturer ID	0100 0110	
F4	D6, D7		0101, 0110	Hard-coded	Sensor Type = Acceleration (high-g)	0000 0001	
F5	D8		0111	Factory Programmed	Axis	0000	
	D9		1000	±60g: 0111 ±120g: 1000 ±240g: 1001 ±480g: 1010	Range	Varies	
F6	D10		1001	DEVCFG2[7:4]	Sensor Specific Information	0000	
	D11		1010	DEVCFG2[3:0]	Sensor Specific Information	0000	
F7	D12		1011	Hard-coded	Product Revision	Factory	
	D13		1100	Hard-coded	Product Revision	Factory	
	D14		1101	DEVCFG6[3:0]	Product Revision	0000	
F8	D15		1110	Factory Programmed		0001	
	D16		1111			0010	
	D17		0000			0000	
	D18	0001	0000				
F9	D19	1	0010	SN0 (High Nibble)	MMA52xx Serial Number	Factory	
	D20		0011	SN0 (Low Nibble)	MMA52xx Serial Number	Factory	
	D21		0100	SN1 (High Nibble)	MMA52xx Serial Number	Factory	
	D22		0101	SN1 (Low Nibble)	MMA52xx Serial Number	Factory	
	D23		0110	SN2 (High Nibble)	MMA52xx Serial Number	Factory	
	D24		0111	SN2 (Low Nibble)	MMA52xx Serial Number	Factory	
	D25		1000	SN3 (High Nibble)	MMA52xx Serial Number	Factory	
	D26		1001	SN3 (Low Nibble)	MMA52xx Serial Number	Factory	
	D27		1010	Factory Programmed			0000
	D28		1011				0000
	D29		1100				0000
	D30		1101				0000
	D31		1110				0000
	D32		1111				0000

4.4.3 Internal Self-Test

During PSI5 Initialization Phase 2 and Phase 3, the device completes it's internal self-test as described below and shown in Figure 25.

- Self-Test Phase 1 - Raw Offset Calculation
 - The average offset is calculated for t_{ST1} (Self-Test Disabled).
- Self-Test Phase 2 - Self-Test Deflection Verification
 - The offset cancellation value is frozen for $t_{ST2} + 2ms$
 - Self-Test is enabled
 - After $t_{ST2}/2$, the acceleration output value is averaged for $t_{ST2}/2$ to determine the self-test value
 - The self-test value is compared against the limits specified in Section 2.5
 - Self-Test is disabled
- Self-Test Phase 3 - Self-Test Normal Data Calculation
 - The average offset is calculated for t_{ST3}
 - If Self-Test passed, the device advances to normal mode
 - If Self-Test failed, the device repeats Self-Test Phases 1 through 3 up to ST_RPT times.

4.4.4 Initialization Phase 3

During PSI5 initialization phase 3, the device completes it's internal self checks, and transmits a combination of “Sensor Busy”, “Sensor Ready”, or “Sensor Defect” messages as defined in Table 7. Self-Test is repeated on failure up to ST_RPT times to provide immunity to misuse inputs during initialization. Self-Test terminates successfully after one successful self-test sequence.

Table 10 shows the nominal Initialization Phase 3 times for self-test repeats. Times are calculated using the following equation.

$$t_{PSI5INIT3} = \text{ROUNDUP}\left(\frac{(t_{INTINIT} + t_{OC1} + t_{OC2} + (t_{ST1} + t_{ST2} + t_{ST3}) \times (STRPT + 1)) - (t_{PSI5INIT1} + t_{PSI5INIT2xx})}{t_{ASYNC}} + 2\right) \times t_{ASYNC}$$

Table 10. Initialization Phase 3 Time

Operating Mode	Self-Test Repetitions	# of Sensor Busy Messages	# of Sensor Ready or Sensor Defect Messages	Nominal Phase 3 Time (ms)
10-Bit Asynchronous Mode 0 (228 μs)	0	2	2	0.91
	1	423		96.90
	2	844		192.89
	3	1265		288.88
	4	1686		384.86
	5	2107		480.85

4.5 Error Handling

4.5.1 Sensor Defect Message

The following failures will cause the device to transmit a “Sensor Defect” error message:

Error Condition	Error Type
Offset Error	Temporary (Normal transmissions continue once offset returns within limits)
Self-Test Failure	Latched until reset
IDEN_B, IDEF_B flag cleared	Latched until reset

4.5.2 No Response Error

The following failures will cause the device to stop transmitting:

Error Condition	Error Type
Undervoltage Failure (V_{CC})	Temporary: Normal transmissions continue once voltage returns above failure limit)

5 Package

5.1 Case Outline Drawing

Reference Freescale Case Outline Drawing # 98ASA00090D

http://www.freescale.com/files/shared/doc/package_info/98ASA00090D.pdf

5.2 Recommended Footprint

Reference Freescale Application Note AN3111, latest revision:

http://www.freescale.com/files/sensors/doc/app_note/AN3111.pdf

Table 11. Revision History

Revision number	Revision date	Description of changes
0	09/2012	<ul style="list-style-type: none"> • Initial release.

How to Reach Us:**Home Page:**

freescale.com

Web Support:

freescale.com/support

Information in this document is provided solely to enable system and software implementers to use Freescale products. There are no express or implied copyright licenses granted hereunder to design or fabricate any integrated circuits based on the information in this document.

Freescale reserves the right to make changes without further notice to any products herein. Freescale makes no warranty, representation, or guarantee regarding the suitability of its products for any particular purpose, nor does Freescale assume any liability arising out of the application or use of any product or circuit, and specifically disclaims any and all liability, including without limitation consequential or incidental damages. "Typical" parameters that may be provided in Freescale data sheets and/or specifications can and do vary in different applications, and actual performance may vary over time. All operating parameters, including "typicals," must be validated for each customer application by customer's technical experts. Freescale does not convey any license under its patent rights nor the rights of others. Freescale sells products pursuant to standard terms and conditions of sale, which can be found at the following address: <http://www.reg.net/v2/webservices/Freescale/Docs/TermsandConditions.htm>.

Freescale, the Freescale logo, Altivec, C-5, CodeTest, CodeWarrior, ColdFire, C-Ware, Energy Efficient Solutions logo, Kinetis, mobileGT, PowerQUICC, Processor Expert, QorIQ, Qorivva, StarCore, Symphony, and VortiQa are trademarks of Freescale Semiconductor, Inc., Reg. U.S. Pat. & Tm. Off. Airfast, BeeKit, BeeStack, ColdFire+, CoreNet, Flexis, MagniV, MXC, Platform in a Package, QorIQ Qonverge, QUICC Engine, Ready Play, SafeAssure, SMARTMOS, TurboLink, Vybrid, and Xtrinsic are trademarks of Freescale Semiconductor, Inc. All other product or service names are the property of their respective owners.

© 2012 Freescale Semiconductor, Inc.

X-ON Electronics

Largest Supplier of Electrical and Electronic Components

Click to view similar products for [Accelerometers](#) category:

Click to view products by [NXP](#) manufacturer:

Other Similar products are found below :

[AD22372Z-RL7](#) [ADXL313WACPZ-RL](#) [805M1-0050-01](#) [MXC6655XA](#) [MMA7455LT](#) [805M1-0200-01](#) [810M1-0025X](#) [AIS328DQTR](#)
[832M1-0050](#) [805-0050](#) [AD22301](#) [ADXL354BEZ](#) [SCA620-EF8H1A-1](#) [MC3413](#) [MXC6244AU](#) [3038-0500](#) [ACH-01-04/10](#) [4692](#)
[ADXL372BCCZ-RL7](#) [735T](#) [787-500](#) [787AM8](#) [793-6](#) [793L](#) [997-M4](#) [HV101](#) [HV102](#) [HV200](#) [PC420VP-50](#) [PC420VR-10](#) [786A](#) [786A-IS](#)
[787A](#) [787A-IS](#) [HT786A](#) [HT787A](#) [PC420VP-10](#) [ADCMXL1021-1BMLZ](#) [ADIS16003CCCZ](#) [ADIS16006CCCZ](#) [ADIS16228CMLZ](#)
[ADXL700WBRWZ-RL](#) [ADXL1003BCPZ](#) [ADXL103CE-REEL](#) [ADXL203CE-REEL](#) [ADXL206HDZ](#) [ADXL213AE](#) [ADXL213AE-REEL](#)
[ADXL288WBRDZ-RL](#) [ADXL295WBRDZ-RL](#)