



NT3H1101/NT3H1201

NTAG I²C - Energy harvesting NFC Forum Type 2 Tag with field detection pin and I²C interface

Rev. 3.3 — 15 July 2015
265433

Product data sheet
COMPANY PUBLIC

1. General description

NTAG I²C - The entry to the NFC world: simple and lowest cost.

The NTAG I²C is the first product of NXP's NTAG family offering both contactless and contact interfaces (see [Figure 1](#)). In addition to the passive NFC Forum compliant contactless interface, the IC features an I²C contact interface, which can communicate with a microcontroller if the NTAG I²C is powered from an external power supply. An additional externally powered SRAM mapped into the memory allows a fast data transfer between the RF and I²C interfaces and vice versa, without the write cycle limitations of the EEPROM memory.

The NTAG I²C product features a configurable field detection pin, which provides a trigger to an external device depending on the activities at the RF interface.

The NTAG I²C product can also supply power to external (low power) devices (e.g. a microcontroller) via the embedded energy harvesting circuitry.

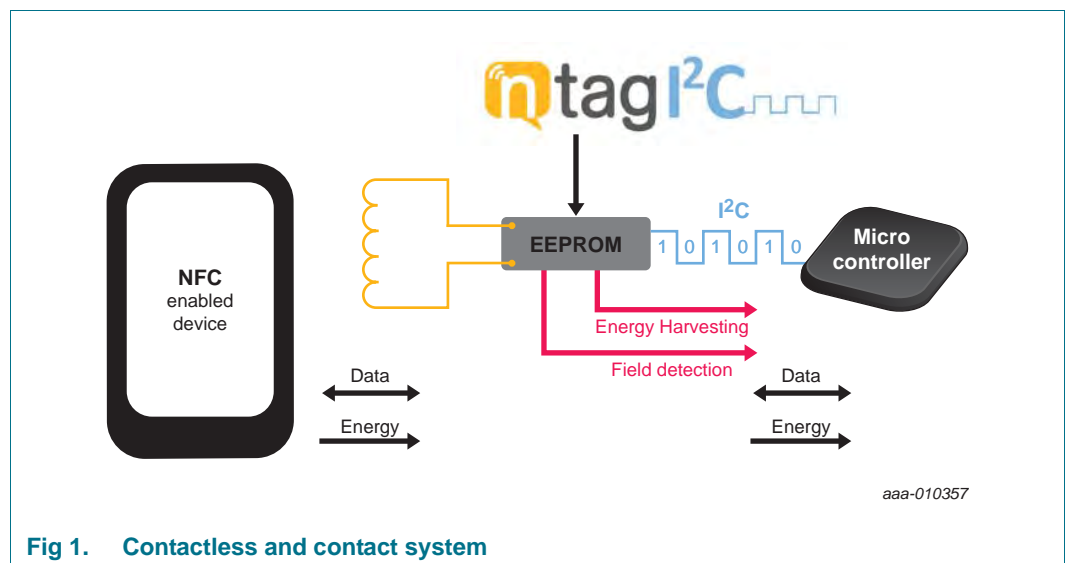

2. Features and benefits

2.1 Key features

- RF interface NFC Forum Type 2 Tag compliant
- I²C interface
- Configurable field detection pin based on open drain implementation that can be triggered upon the following events:
 - ◆ RF field presence
 - ◆ First start of communication
 - ◆ Selection of the tag only
- 64 byte SRAM buffer for fast transfer of data (Pass-through mode) between the RF and the I²C interfaces located outside the User Memory
- Wake up signal at the field detect pin when:
 - ◆ New data has arrived from one interface
 - ◆ Data has been read by the receiving interface
- Clear arbitration between RF and I²C interfaces:
 - ◆ First come, first serve strategy
 - ◆ Status flag bits to signal if one interface is busy writing to or reading data from the EEPROM
- Energy harvesting functionality to power external devices (e.g. microcontroller)
- FAST READ command for faster data reading

2.2 RF interface

- Contactless transmission of data
- NFC Forum Type 2 Tag compliant (see [Ref. 1](#))
- Operating frequency of 13.56 MHz
- Data transfer of 106 kbit/s
- 4 bytes (one page) written including all overhead in 4.8 ms via EEPROM or 0.8 ms via SRAM (Pass-through mode)
- Data integrity of 16-bit CRC, parity, bit coding, bit counting
- Operating distance of up to 100 mm (depending on various parameters, such as field strength and antenna geometry)
- True anticollision
- Unique 7 byte serial number (cascade level 2 according to ISO/IEC 14443-3 (see [Ref. 2](#)))

2.3 Memory

- 1904 bytes freely available with User Read/Write area (476 pages with 4 bytes per pages) for the NTAG I²C 2k version
- 888 bytes freely available with User Read/Write area (222 pages with 4 bytes per pages) for the NTAG I²C 1k version
- Field programmable RF read-only locking function with static and dynamic lock bits configurable from both I²C and NFC interfaces
- 64 bytes SRAM volatile memory without write endurance limitation

- Data retention time of 20 years
- Write endurance 500,000 cycles

2.4 I²C interface

- I²C slave interface supports Standard (100 kHz) and Fast (up to 400 kHz) mode (see [Ref. 3](#))
- 16 bytes (one block) written in 4.5 ms (EEPROM) or 0.4 ms (SRAM - Pass-through mode) including all overhead
- RFID chip can be used as standard I²C EEPROM

2.5 Security

- Manufacturer-programmed 7-byte UID for each device
- Capability container with one time programmable bits
- Field programmable read-only locking function per page for first 12 pages and per 16 (1k version) or 32 (2k version) pages for the extended memory section

2.6 Key benefits

- The Pass-through mode allows fast download and upload of data from RF to I²C and vice versa without the cycling limitation of EEPROM
- NDEF message storage up to 1904 bytes (2k version) or up to 888 bytes (1k version)
- The mapping of the SRAM inside the User Memory buffer allows dynamic update of NDEF message content

3. Applications

With all its integrated features and functions the NTAG I²C is the ideal solution to enable a contactless communication via an NFC device (e.g., NFC enabled mobile phone) to an electronic device for:

- Zero power configuration (late customization)
- Smart customer interaction (e.g., easier after sales service, such as firmware update)
- Advanced pairing (for e.g., WiFi or Blue tooth) for dynamic generation of sessions keys

Easier product customization and customer experience for the following applications:

- Home automation
- Home appliances
- Consumer electronics
- Healthcare
- Printers
- Smart meters

4. Ordering information

Table 1. Ordering information

Type number	Package		Version
	Name	Description	
NT3H1101W0FUG	FFC bumped	8 inch wafer, 150um thickness, on film frame carrier, electronic fail die marking according to SECS-II format), Au bumps, 1k Bytes memory, 50pF input capacitance	-
NT3H1201W0FUG	FFC bumped	8 inch wafer, 150um thickness, on film frame carrier, electronic fail die marking according to SECS-II format), Au bumps, 2k Bytes memory, 50pF input capacitance	-
NT3H1101W0FHK	XQFN8	Plastic, extremely thin quad flat package; no leads; 8 terminals; body 1.6 x 1.6 x 0.6mm; 1k bytes memory, 50pF input capacitance	SOT902-3
NT3H1201W0FHK	XQFN8	Plastic, extremely thin quad flat package; no leads; 8 terminals; body 1.6 x 1.6 x 0.6mm; 2k bytes memory, 50pF input capacitance	SOT902-3
NT3H1101W0FTT	TSSOP8	Plastic thin shrink small outline package; 8 leads; body width 3 mm; 1k bytes memory; 50pF input capacitance	SOT505-1
NT3H1201W0FTT	TSSOP8	Plastic thin shrink small outline package; 8 leads; body width 3 mm; 2k bytes memory; 50pF input capacitance	SOT505-1

5. Marking

Table 2. Marking codes

Type number	Marking code
NT3H1201FHK	N12
NT3H1101FHK	N11
NT3H1101W0FFT	31101
NT3H1201W0FFT	31201

6. Block diagram

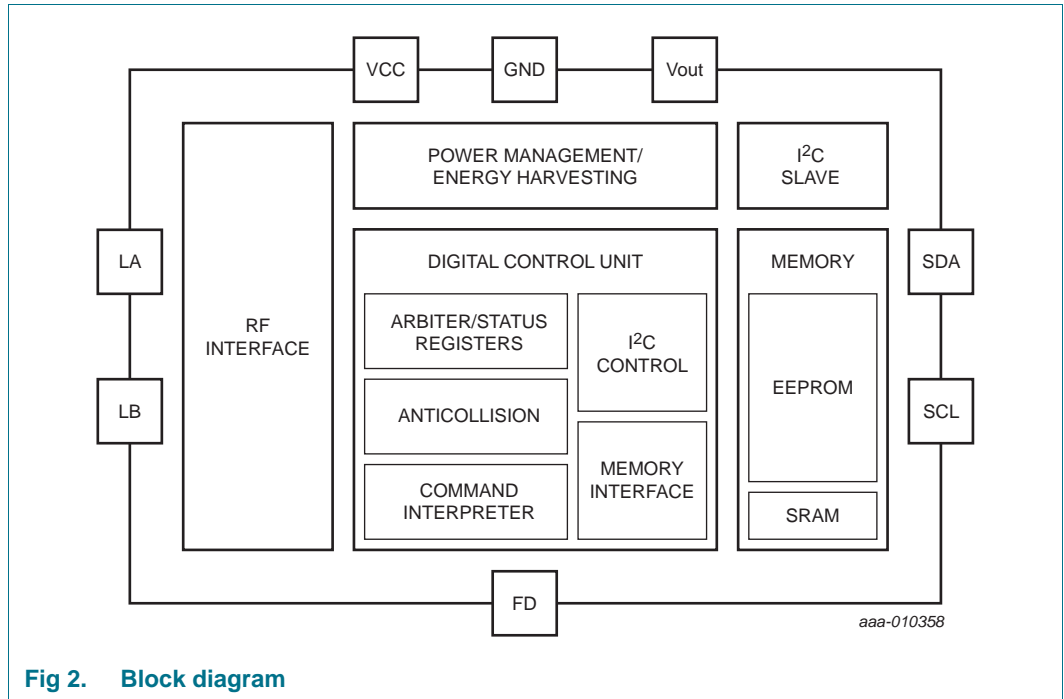
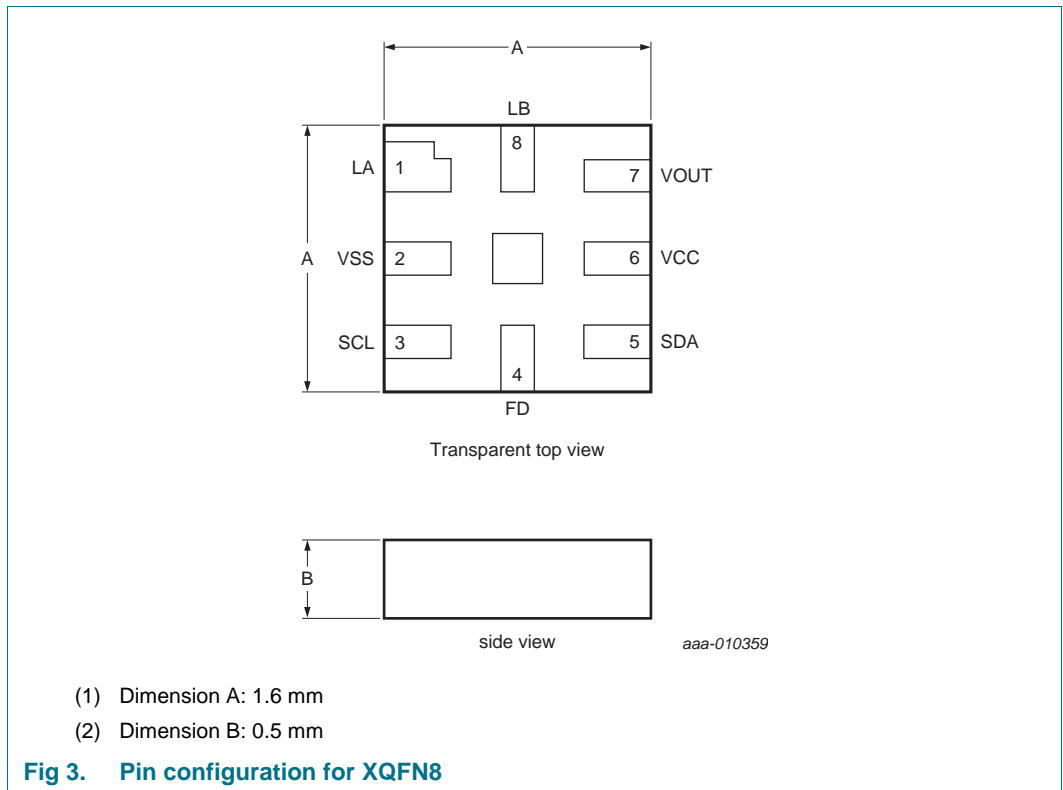

Fig 2. Block diagram

7. Pinning information

7.1 Pinning

7.1.1 XQFN8



7.1.2 TSSOP8

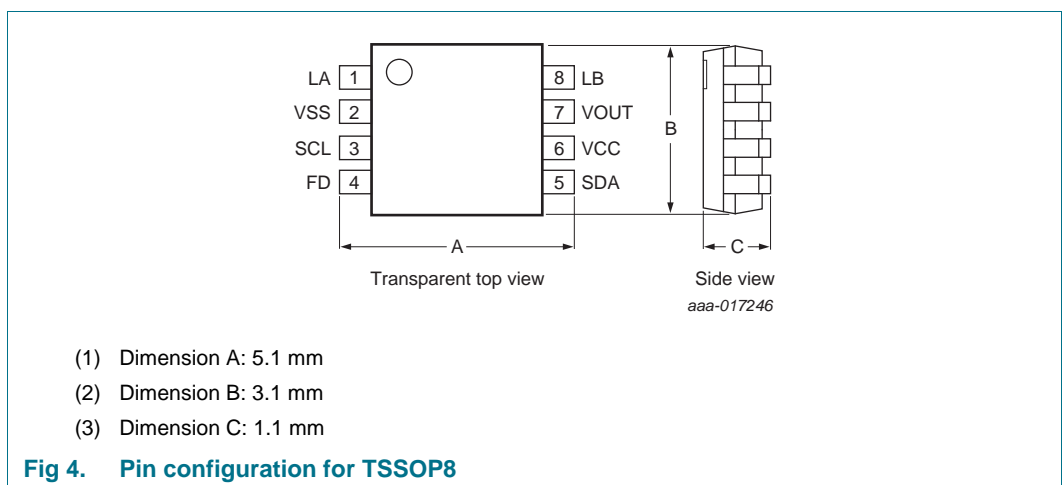

7.2 Pin description

Table 3. Pin description for XQFN8 and TSSOP8

Pin	Symbol	Description
1	LA	Antenna connection LA
2	VSS	GND
3	SCL	Serial Clock I ² C
4	FD	Field detection
5	SDA	Serial data I ² C
6	VCC	VCC in connection (external power supply)
7	VOUT	Voltage out (energy harvesting)
8	LB	Antenna connection LB

NXP recommends leaving the central pad of the XQFN8 package unconnected.

8. Functional description

8.1 Block description

NTAG I²C ICs consist of (see details below): 2016 bytes of EEPROM memory, 64 Bytes of SRAM, a RF interface, Digital Control Unit (DCU), Power Management Unit (PMU) and an I²C interface. Energy and data are transferred via an antenna consisting of a coil with a few turns, which is directly connected to NTAG I²C IC.

- RF interface:
 - modulator/demodulator
 - rectifier
 - clock regenerator
 - Power-On Reset (POR)
 - voltage regulator
- Anticollision: multiple cards may be selected and managed in sequence
- Command interpreter: processes memory access commands supported by the NTAG I²C
- EEPROM interface

8.2 RF interface

The RF-interface is based on the ISO/IEC 14443 Type A standard.

This RF interface is passive and therefore requires to be supplied by an RF field (e.g. NFC enabled device) at all times to be able to operate. It is not operating even if the NTAG I²C is powered via its contact interface (V_{CC}).

Data transmission from the RF interface is only happening if RF field from an NFC enabled device is available and adequate commands are sent to retrieve data from the NTAG I²C.

For both directions of data communication, there is one start bit (start of communication) at the beginning of each frame. Each byte is transmitted with an odd parity bit at the end. The LSB of the byte with the lowest address of the selected block is transmitted first.

The maximum length of an NFC device to tag frame used in this product is 82 bits (7 data bytes + 2 CRC bytes = 7×9 + 2×9 + 1 start bit).

The maximum length of a tag to NFC device frame (response to READ command) is 163 bits (16 data bytes + 2 CRC bytes = 16 × 9 + 2 × 9 + 1 start bit).

In addition the proprietary FAST_READ command has a variable response frame length, which depends on the start and end address parameters. E.g. when reading the SRAM at once the length of the response is 595 bits (64 data bytes + 2 CRC bytes = 64 × 9 + 2 × 9 + 1 start bit). The overall maximum supported response frame length for FAST READ is up to 9235 bits (1024 data bytes + 2 CRC bytes = 1024 × 9 + 2 × 9 + 1 start bit), but here the maximum frame length supported by the NFC device must be taken into account when issuing this command.

For a multi-byte parameter, the least significant byte is always transmitted first. For example, when reading from the memory using the READ command, byte 0 from the addressed block is transmitted first, followed by bytes 1 to byte 3 out of this block. The same sequence continues for the next block and all subsequent blocks.

8.2.1 Data integrity

The following mechanisms are implemented in the contactless communication link between the NFC device and the NTAG I²C IC to ensure very reliable data transmission:

- 16 bits CRC per block
- Parity bits for each byte
- Bit count checking
- Bit coding to distinguish between “1”, “0” and “no information”
- Channel monitoring (protocol sequence and bit stream analysis)

The commands are initiated by the NFC device and controlled by the Digital Control Unit of the NTAG I²C IC. The command response depends on the state of the IC, and for memory operations, also on the access conditions valid for the corresponding page.

8.2.2 RF communication principle

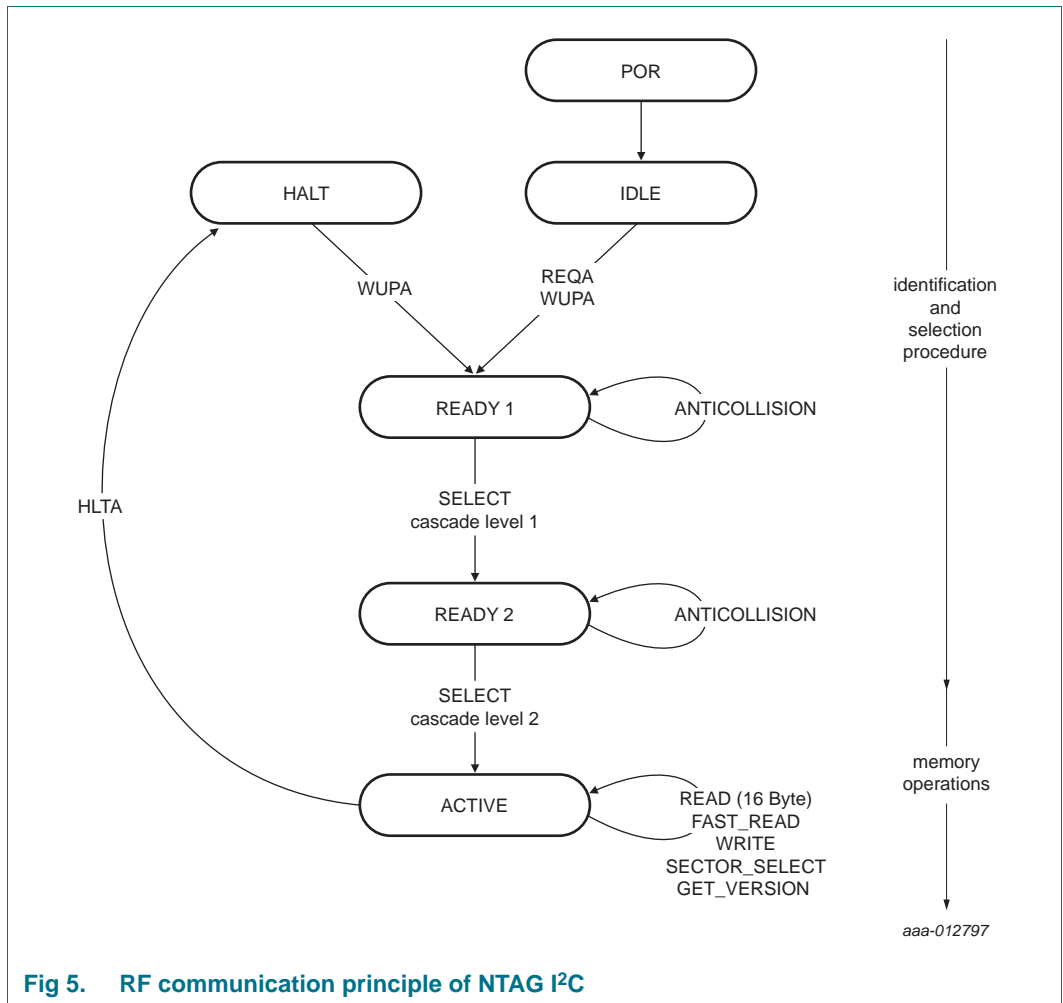

Fig 5. RF communication principle of NTAG I²C

The overall RF communication principle is summarized in [Figure 5](#).

8.2.2.1 IDLE state

After a power-on reset (POR), the NTAG I²C switches to the IDLE state. It only exits this state when a REQA or a WUPA command is received from the NFC device. Any other data received while in this state is interpreted as an error, and the NTAG I²C remains in the IDLE state.

After a correctly executed HLTA command e.g., out of the ACTIVE state, the default waiting state changes from the IDLE state to the HALT state. This state can then only be exited with a WUPA command.

8.2.2.2 READY 1 state

In the READY 1 state, the NFC device resolves the first part of the UID (3 bytes) using the ANTICOLLISION or SELECT commands in cascade level 1. This state is correctly exited after execution of the following command:

- SELECT command from cascade level 1: the NFC device switches the NTAG I²C into READY2 state where the second part of the UID is resolved.

8.2.2.3 READY 2 state

In the READY 2 state, the NTAG I²C supports the NFC device in resolving the second part of its UID (4 bytes) with the cascade level 2 ANTICOLLISION command. This state is usually exited using the cascade level 2 SELECT command.

Remark: The response of the NTAG I²C to the SELECT command is the Select Acknowledge (SAK) byte. In accordance with ISO/IEC 14443, this byte indicates if the anticollision cascade procedure has finished. If finished, the NTAG I²C is now uniquely selected and only this device will communicate with the NFC device even when other contactless devices are present in the NFC device field.

8.2.2.4 ACTIVE state

All memory operations are operated in the ACTIVE state.

The ACTIVE state is exited with the HLTA command and upon reception, the NTAG I²C transits to the HALT state. Any other data received when the device is in this state is interpreted as an error. Depending on its previous state, the NTAG I²C returns to either to the IDLE state or HALT state.

8.2.2.5 HALT state

HALT and IDLE states constitute the two wait states implemented in the NTAG I²C. An already processed NTAG I²C can be set into the HALT state using the HLTA command. In the anticollision phase, this state helps the NFC device distinguish between processed tags and tags yet to be selected. The NTAG I²C can only exit this state upon execution of the WUPA command. Any other data received when the device is in this state is interpreted as an error, and NTAG I²C state remains unchanged.

8.3 Memory organization

The memory map is detailed in [Table 4](#) (1k memory) and [Table 5](#) (2k memory) from the RF interface and in [Table 6](#) (1k memory) and [Table 7](#) (2k memory) from the I²C interface. The SRAM memory is not mapped from the RF interface, because in the default settings of the NTAG I²C the Pass-through mode is not enabled. Please refer to [Section 11](#) for examples of memory map from the RF interface with SRAM mapping.

The structure of manufacturing data, static lock bytes, capability container and user memory pages (except of the user memory length) are compatible with other NTAG products.

Any memory access which starts at a valid address and extends into an invalid access region will return 00h value in the invalid region.

8.3.1 Memory map from RF interface

Memory access from the RF interface is organized in pages of 4 bytes each.

Table 4. NTAG I²C 1k memory organization from the RF interface

Sector address	Page address		Byte number within a page				Access conditions
	Dec.	Hex.	0	1	2	3	
0	0	00h	Serial number				READ
	1	01h	Serial number		Internal		READ
	2	02h	Internal		Static lock bytes		READ/R&W
	3	03h	Capability Container (CC)				READ&WRITE
	4	04h	User memory				READ&WRITE
					
	15	0Fh					
					
	225	E1h					
	226	E2h	Dynamic lock bytes		00h		R&W/READ
	227	E3h	Invalid access - returns NAK				n.a.
	228	E4h					
	229	E5h					
	230	E6h					
	231	E7h					
	232	E8h	Configuration registers				see 8.3.11
	233	E9h					
	234	EAh					
	Invalid access - returns NAK				n.a.
255	FFh						
1	Invalid access - returns NAK				n.a.
2	Invalid access - returns NAK				n.a.
3	0	00h	Invalid access - returns NAK				n.a.
					
	248	F8h	Session registers				see 8.3.11
	249	F9h					
	Invalid access - returns NAK				n.a.
255	FFh						

Table 5. NTAG I²C 2k memory organization from the RF interface

Sector address	Page address		Byte number within a page				Access conditions
	Dec.	Hex.	0	1	2	3	
0	0	00h	Serial number				READ
	1	01h	Serial number		Internal		READ
	2	02h	Internal		Static lock bytes		READ/R&W
	3	03h	Capability Container (CC)				READ&WRITE
	4	04h	User memory				READ&WRITE
					
	15	0Fh					
					
	255	FFh					
1	0	...	User memory				READ&WRITE
	1	...					
					
					
	223	DFh					
	224	E0h	Dynamic lock bytes		00h		R&W/READ
	225	E1h	Invalid access - returns NAK				n.a.
	226	E2h					
	227	E3h					
	228	E4h					
	229	E5h					
	230	E6h					
	231	E7h	Configuration registers				see 8.3.11
	232	E8h					
	233	E9h					
	234	EAh	Invalid access - returns NAK				n.a.
					
255	FFh						
2	Invalid access - returns NAK				n.a.
3	0	00h	Invalid access - returns NAK				n.a.
					
	248	F8h	Session registers				see 8.3.11
	249	F9h					
	Invalid access - returns NAK				n.a.
255	FFh						

8.3.2 Memory map from I²C interface

The memory access of NTAG I²C from the I²C interface is organized in blocks of 16 bytes each.

Table 6. NTAG I²C 1k memory organization from the I²C interface

I ² C block address		Byte number within a block				Access conditions
		0	1	2	3	
		4	5	6	7	
		8	9	10	11	
Dec.	Hex.	12	13	14	15	
0	00h	I ² C addr.*	Serial number			R&W/READ
		Serial number			Internal	READ
		Internal		Static lock bytes		READ/R&W
		Capability Container (CC)				READ&WRITE
1	01h	User memory				READ&WRITE
...	...					
55	37h					
56	38h	User memory				READ&WRITE
		User memory				READ&WRITE
		Dynamic lock bytes			00h	READ&WRITE
		00h	00h	00h	00h	READ
57	39h	Invalid access - returns NAK				n.a.
58	3Ah	Configuration registers				see 8.3.11
		00h	00h	00h	00h	READ
		00h	00h	00h	00h	
59	3Bh	Invalid access - returns NAK				n.a.
...	...					
247	F7h					
248	F8h	SRAM memory (64 bytes)				READ&WRITE
...	...					
251	FBh					
...	...	Invalid access - returns NAK				n.a.
254	FEh	Session registers (requires READ register command)				see 8.3.11
		00h	00h	00h	00h	READ
		00h	00h	00h	00h	
...	...	Invalid access - returns NAK				n.a.

Remark: * The byte 0 of block 0 is always read as 04h. Writing to this byte modifies the I²C address.

Table 7. NTAG I²C 2k memory organization from the I²C interface

I ² C block address		Byte number within a block				Access conditions
		0	1	2	3	
		4	5	6	7	
		8	9	10	11	
Dec.	Hex.	12	13	14	15	
0	00h	I ² C addr.*	Serial number			R&W/READ
		Serial number			Internal	READ
		Internal		Static lock bytes		READ/R&W
		Capability Container (CC)				READ&WRITE
1	01h	User memory				READ&WRITE
...	...					
119	77h					
120	78h	Dynamic lock bytes			00h	READ&WRITE
		00h	00h	00h	00h	READ
		00h	00h	00h	00h	
		00h	00h	00h	00h	
121	79h	Invalid access - returns NAK				n.a.
122	7Ah	Configuration registers				see 8.3.11
		00h	00h	00h	00h	READ
		00h	00h	00h	00h	
127	7Bh	Invalid access - returns NAK				n.a.
...	...					
247	F7h					
248	F8h	SRAM memory (64 bytes)				READ&WRITE
...	...					
251	FBh					
...	...	Invalid access - returns NAK				n.a.
254	FEh	Session registers (requires READ register command)				see 8.3.11
		00h	00h	00h	00h	READ
		00h	00h	00h	00h	
...	...	Invalid access - returns NAK				n.a.

Remark: * The byte 0 of block 0 is always read as 04h. Writing to this byte modifies the I²C address.

8.3.3 EEPROM

The EEPROM is a non volatile memory that stores the 7 byte UID, the memory lock conditions, IC configuration information and the 1904 bytes user data (888 byte user data in case of the NTAG I²C 1k version).

8.3.4 SRAM

For frequently changing data, a volatile memory of 64 bytes with unlimited endurance is built in. The 64 bytes are mapped in a similar way as done in the EEPROM, i.e., 64 bytes are seen as 16 pages of 4 bytes.

The SRAM is only available if the tag is powered via the VCC pin.

The SRAM is located at the end of the memory space and it is always directly accessible by the I²C host (addresses F8h to FBh). An RF reader cannot access the SRAM memory in normal mode (i.e., outside the Pass-through mode). The SRAM is only accessible by the RF reader if the SRAM is mirrored onto the EEPROM memory space.

With Memory Mirror enabled (SRAM_MIRROR_ON_OFF = 1b - see [Section 11.2](#)), the SRAM can be mirrored in the User Memory (page 1 to page 116 - see [Section 11.2](#)) for access from the RF side.

The Memory mirror must be enabled once both interfaces are ON as this feature is disabled after each POR.

The register SRAM_MIRROR_BLOCK (see [Table 14](#)) indicates the address of the first page of the SRAM buffer. In the case where the SRAM mirror is enabled and the READ command is addressing blocks where the SRAM mirror is located, the SRAM mirror byte values will be returned instead of the EEPROM byte values. Similarly, if the tag is not VCC powered, the SRAM mirror is disabled and reading out the bytes related to the SRAM mirror position would return the values from the EEPROM.

In the Pass-through mode (PTHRU_ON_OFF = 1b - see [Section 8.3.11](#)), the SRAM is mirrored to the fixed address 240 - 255 for RF access (see [Section 11](#)) in the first memory sector for NTAG I²C 1k and in the second memory sector for NTAG I²C 2k.

8.3.5 UID/serial number

The unique 7-byte serial number (UID) is programmed into the first 7 bytes of memory covering page addresses 00h and 01h - see [Figure 6](#). These bytes are programmed and write protected in the production test.

SN0 holds the Manufacturer ID for NXP Semiconductors (04h) in accordance with ISO/IEC 14443-3.

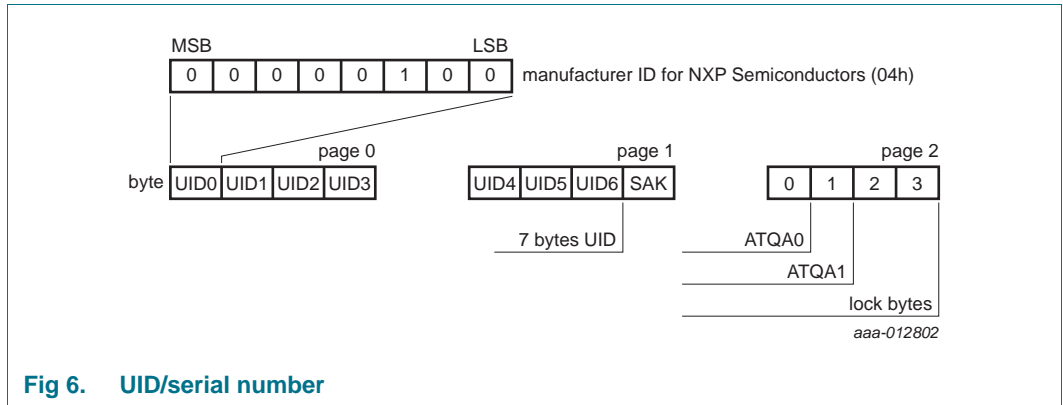

Fig 6. UID/serial number

8.3.6 Static lock bytes

The bits of byte 2 and byte 3 of page 02h (via RF) or byte 10 and 11 address 0h (via I²C) represent the field programmable, read-only locking mechanism (see Figure 7). Each page from 03h (CC) to 0Fh can be individually locked by setting the corresponding locking bit L_x to logic 1 to prevent further write access. After locking, the corresponding page becomes read-only memory.

The three least significant bits of lock byte 0 are the block-locking bits. Bit 2 controls pages 0Ah to 0Fh (via RF), bit 1 controls pages 04h to 09h (via RF) and bit 0 controls page 03h (CC). Once the block-locking bits are set, the locking configuration for the corresponding memory area is frozen.

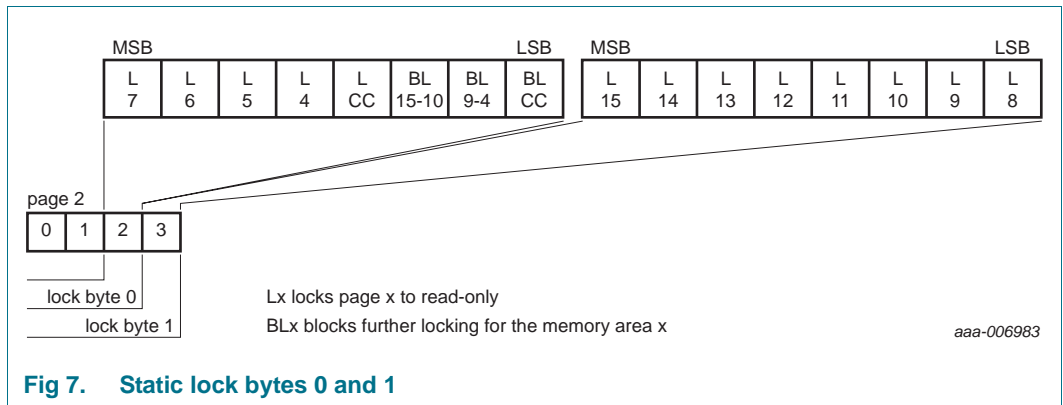

Fig 7. Static lock bytes 0 and 1

For example, if BL15-10 is set to logic 1, then bits L15 to L10 (lock byte 1, bit[7:2]) can no longer be changed. The static locking and block-locking bits are set by the bytes 2 and 3 of the WRITE command to page 02h. The contents of the lock bytes are bit-wise OR'ed and the result then becomes the new content of the lock bytes.

This process is irreversible from RF perspective. If a bit is set to logic 1, it cannot be changed back to logic 0. From I²C perspective, the bits can be reset to 0b by writing bytes 10 and 11 of block 0. I²C address is coded in byte 0 of block 0 and may be changed unintentionally.

The contents of bytes 0 and 1 of page 02h are unaffected by the corresponding data bytes of the WRITE.

The default value of the static lock bytes is 00 00h.

8.3.7 Dynamic Lock Bytes

To lock the pages of NTAG I²C starting at page address 10h and onwards, the dynamic lock bytes are used. The dynamic lock bytes are located at page E2h sector 0 (NTAG I2C 1k) or address E0h sector 1 (NTAG I2C 2k). The three lock bytes cover the memory area of 830 data bytes (NTAG I2C 1k) or 1846 data bytes (NTAG I2C 2k). The granularity is 16 pages for NTAG I2C 1k (see [Figure 8](#)) and 32 pages for NTAG I2C 2k (see [Figure 9](#)) compared to a single page for the first 48 bytes (see [Figure 7](#)).

Remark: Set all bits marked with RFUI to 0 when writing to the dynamic lock bytes.

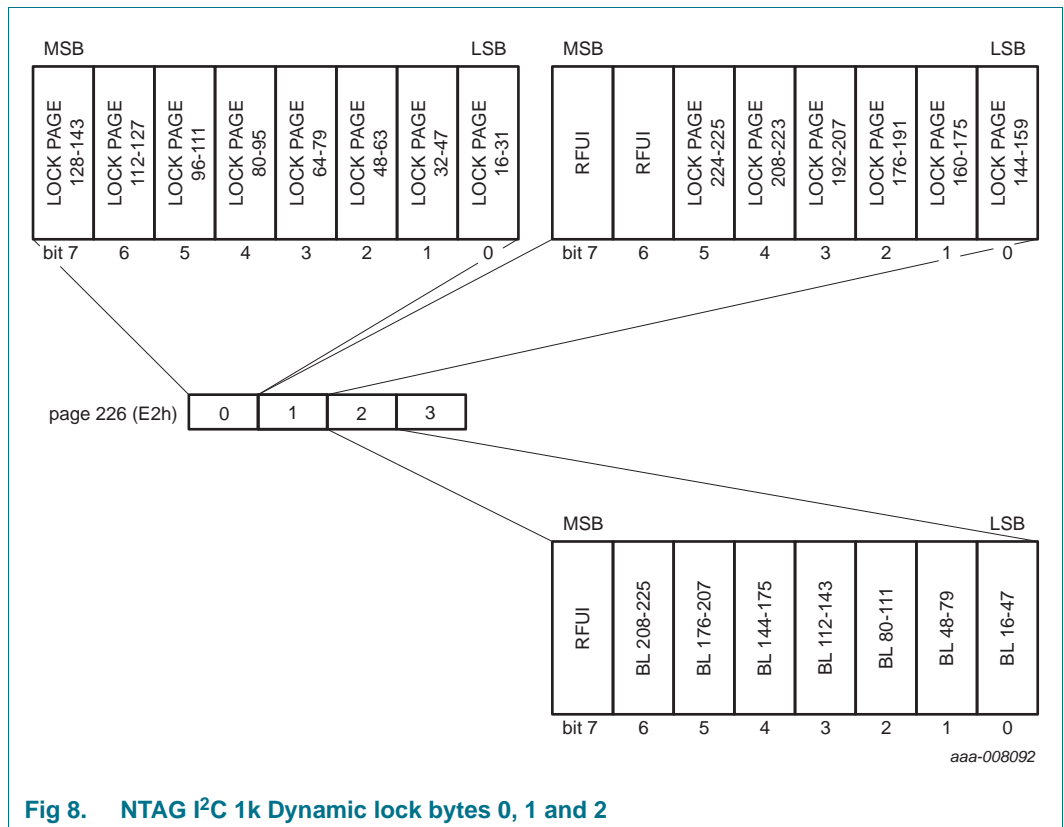

Fig 8. NTAG I²C 1k Dynamic lock bytes 0, 1 and 2

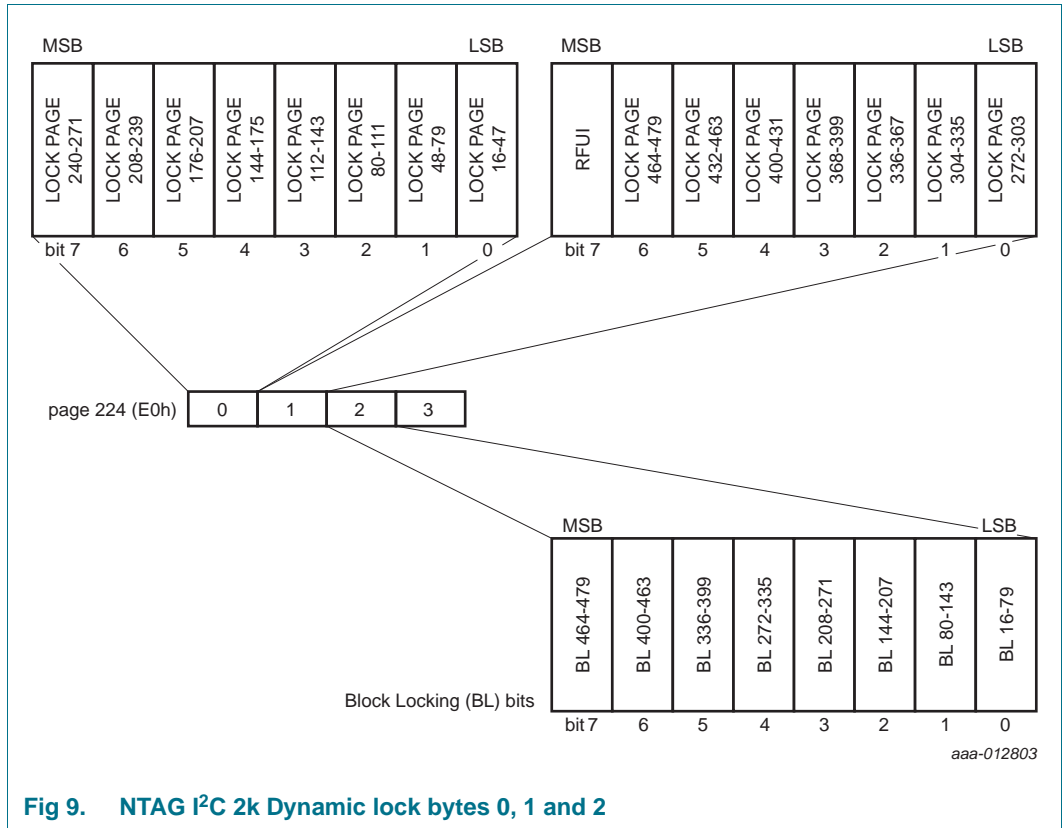

Fig 9. NTAG I²C 2k Dynamic lock bytes 0, 1 and 2

The default value of the dynamic lock bytes is 00 00 00h. The value of Byte 3 is always 00h when read.

Reading the 3 bytes for the dynamic lock bytes and the Byte 3 (00h) from RF interface (address E2h sector 0 (NTAG I²C 1k) or E0h sector 1 (NTAG I²C 2k) or from I²C (address 38h (NTAG I²C 1k) or 78h (NTAG I²C 2k)) will also return a fixed value for the next 12 bytes of 00h.

Like for the static lock bytes, this process of modifying the dynamic lock bytes is irreversible from RF perspective. If a bit is set to logic 1, it cannot be changed back to logic 0. From I²C perspective, the bits can be reset to 0b.

8.3.8 Capability Container (CC bytes)

The Capability Container CC (page 03h) is programmed during the IC production according to the NFC Forum Type 2 Tag specification (see [Ref. 1](#)). These bytes may be bit-wise modified by a WRITE command from the I²C or RF interface. Once set to 1b, it is only possible to reset it to 0b from I²C perspective. I²C address (byte 0) and static lock bytes (byte 10 and byte 11) are coded in block 0 and may be changed unintentionally.

See examples for NTAG I²C 1k version in [Figure 10](#) and for NTAG I²C 2k version in [Figure 11](#).

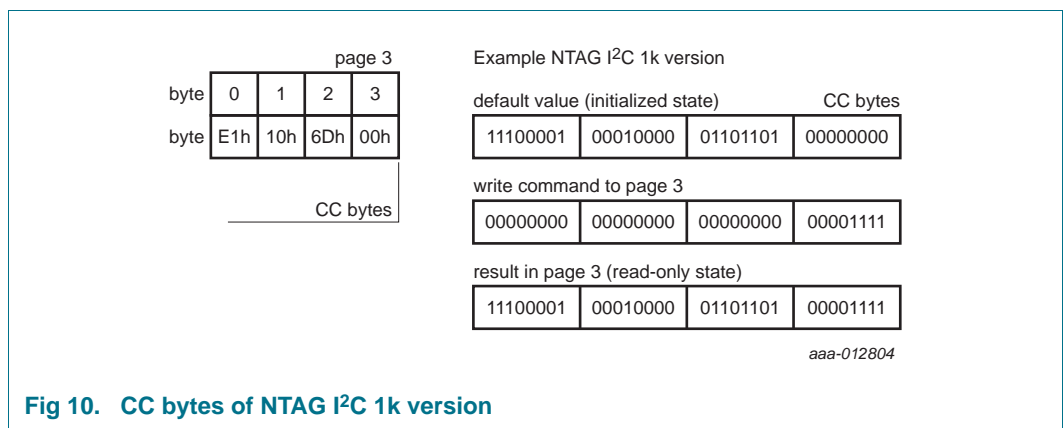

Fig 10. CC bytes of NTAG I²C 1k version

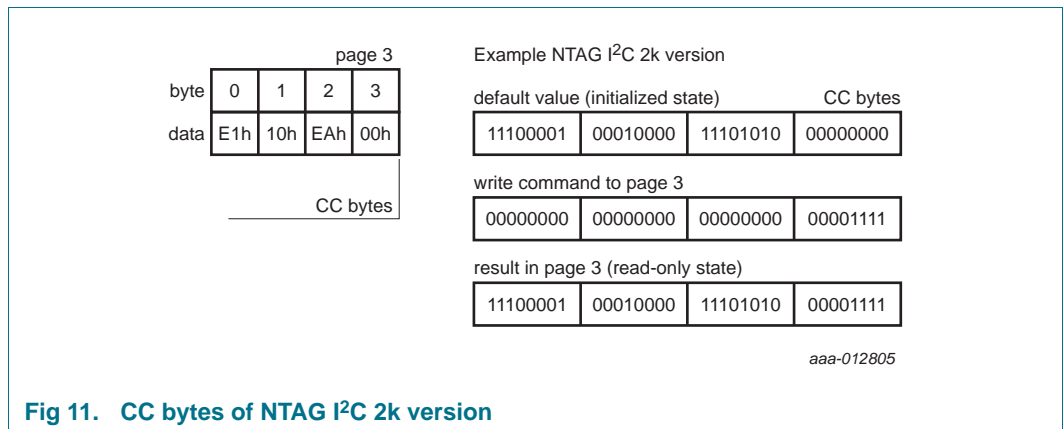

Fig 11. CC bytes of NTAG I²C 2k version

The default values of the CC bytes at delivery are defined in [Section 8.3.10](#).

8.3.9 User Memory pages

Pages 04h to E1h via the RF interface - Block 01h to 37h, plus the first 8 bytes of block 38h via the I²C interface are the user memory read/write areas for NTAG I²C 1k version.

Pages 04h (sector 0) to DFh (sector 1) via the RF interface - Block 1h to 77h via the I²C interface are the user memory read/write areas for NTAG I²C 2k version.

The default values of the data pages at delivery are defined in [Section 8.3.10](#).

8.3.10 Memory content at delivery

The capability container in page 03h and the page 04h and 05h of NTAG I²C is pre-programmed to the initialized state according to the NFC Forum Type 2 Tag specification (see [Ref. 1](#)) as defined in [Table 8](#) (NTAG I²C 1k version) and [Table 9](#) (NTAG I²C 2k version). This content is READ only from the RF side and READ&WRITE from the I²C side.

The User memory contains an empty NDEF TLV.

Remark: The default content of the data pages from page 05h onwards is not defined at delivery.

Table 8. Memory content at delivery NTAG I²C 1k version

Page Address	Byte number within page			
	0	1	2	3
03h	E1h	10h	6Dh	00h
04h	03h	00h	FEh	00h
05h	00h	00h	00h	00h

Table 9. Memory content at delivery NTAG I²C 2k version

Page Address	Byte number within page			
	0	1	2	3
03h	E1h	10h	EAh	00h
04h	03h	00h	FEh	00h
05h	00h	00h	00h	00h

8.3.11 NTAG I²C configuration and session registers

NTAG I²C functionalities can be configured and read in two separate locations depending if the configurations shall be effective within the communication session (session registers) or by default after Power On Reset (POR) (configuration bits).

The configuration registers of pages E8h to E9h (sector 0 - see [Table 10](#), or 1 - see [Table 11](#), depending if it is for NTAG I²C 1k or 2k) via the RF interface or block 3Ah or 7Ah (depending if it is for NTAG I²C 1k or 2k) via the I²C interface are used to configure the default functionalities of the NTAG I²C. Those bit values are stored in the EEPROM and represent the default settings to be effective after POR. Their values can be read & written by both interfaces when applicable and when not locked by the register lock bits (see REG_LOCK in [Table 13](#)).

Table 10. Configuration registers NTAG I²C 1k

RF address (sector 0)		I ² C Address		Byte number			
Dec	Hex	Dec	Hex	0	1	2	3
232	E8h	58	3Ah	NC_REG	LAST_NDEF_BLOCK	SRAM_MIRROR_BLOCK	WDT_LS
233	E9h			WDT_MS	I2C_CLOCK_STR	REG_LOCK	00h fixed

Table 11. Configuration registers NTAG I²C 2k

RF address (sector 1)		I ² C Address		Byte number			
Dec	Hex	Dec	Hex	0	1	2	3
232	E8h	122	7Ah	NC_REG	LAST_NDEF_BLOCK	SRAM_MIRROR_BLOCK	WDT_LS
233	E9h			WDT_MS	I2C_CLOCK_STR	REG_LOCK	00h fixed

The session registers Pages F8h to F9h (sector 3) via the RF interface or block FEh via I²C, see [Table 12](#), are used to configure or monitor the values of the current communication session. Those bits can only be read via the RF interface but both read and written via the I²C interface.

Table 12. Session registers NTAG I²C 1k and 2k

RF address (sector 3)		I ² C Address		Byte number			
Dec	Hex	Dec	Hex	0	1	2	3
248	F8h	254	FEh	NC_REG	LAST_NDEF_BLOCK	SRAM_MIRROR_BLOCK	WDT_LS
249	F9h			WDT_MS	I2C_CLOCK_STR	NS_REG	00h fixed

Both the session and the configuration bits have the same register except the REG_LOCK bits, which are only available in the configuration bits and the NS_REG bits which are only available in the session registers. After POR, the configuration bits are loaded into the session registers. During the communication session, the values can be changed, but the related effect will only be visible within the communication session for the session registers or after POR for the configuration bits. After POR, the registers values will be again brought back to the default configuration values.

All registers and configuration default values, access conditions and descriptions are defined in [Table 13](#) and [Table 14](#).

Reading and writing the session registers via I²C can only be done via the READ and WRITE registers operation - see [Section 9.8](#).

Table 13. Configuration bytes

Bit	Field	Access via RF	Access via I ² C	Default values	Description
Configuration register: NC_REG					
7	I2C_RST_ON_OFF	R&W	R&W	0b	enables soft reset through I ² C repeated start - see Section 9.3
6	RFU	READ	R&W	0b	reserved for future use - keep at 0b
5	FD_OFF	R&W	R&W	00b	defines the event upon which the signal output on the FD pin is brought up 00b... if the field is switched off 01b... if the field is switched off or the tag is set to the HALT state 10b... if the field is switched off or the last page of the NDEF message has been read (defined in LAST_NDEF_BLOCK) 11b... (if FD_ON = 11b) if the field is switched off or if last data is read by I ² C (in Pass-through mode RF --> I ² C) or last data is written by I ² C (in Pass-through mode I ² C--> RF) 11b... (if FD_ON = 00b or 01b or 10b) if the field is switched off See Section 8.4 for more details
4					
3	FD_ON	R&W	R&W	00b	defines the event upon which the signal output on the FD pin is brought down 00b... if the field is switched on 01b... by first valid start of communication (SoC) 10b... by selection of the tag 11b (in Pass-through mode RF-->I ² C) if the data is ready to be read from the I ² C interface 11b (in Pass-through mode I ² C--> RF) if the data is read by the RF interface See Section 8.4 for more details
2					
1	RFU	READ	R&W	0b	reserved for future use - keep at 0b
0	TRANSFER_DIR	R&W	R&W	1b	defines the data flow direction for the data transfer 0b... From I ² C to RF interface 1b... From RF to I ² C interface In case the Pass-through mode is not enabled 0b... no WRITE access from the RF side

Table 13. ...continued Configuration bytes

Bit	Field	Access via RF	Access via I ² C	Default values	Description
Configuration register: LAST_NDEF_BLOCK					
7-0	LAST_NDEF_BLOCK	R&W	R&W	00h	Address of last BLOCK (16bytes) of NDEF message from I ² C addressing. An RF read of the last page of the I ² C block, specified by LAST_NDEF_BLOCK sets the register NDEF_DATA_READ to 1b and triggers FD_OFF if FD_OFF is set to 10b 01h is page 04h (first page of the User Memory) from RF addressing 02h is page 08h 03h is page 0Ch 37h is page DCh - memory sector 0 (last possible page of User memory for NTAG I ² C 1k) 77h is page DCh - memory sector 1 (last page possible of the User Memory for NTAG I ² C 2k)
Configuration register: SRAM_MIRROR_BLOCK					
7-0	SRAM_MIRROR_BLOCK	R&W	R&W	F8h	Address of first BLOCK (16bytes) of SRAM buffer when mirrored into the User memory from I ² C addressing 01h is page 04h (first page of the User Memory) from RF addressing 02h is page 08h 03h is page 0Ch 34h is page D0h - memory sector 0 (last possible page of User memory for NTAG I ² C 1k) 74h is page D0h - memory sector 1 (last page possible of the User Memory for NTAG I ² C 2k)
Configuration register: WDT_LS					
7-0	WDT_LS	R&W	R&W	48h	Least Significant byte of watchdog time control register

Table 13. ...continued Configuration bytes

Bit	Field	Access via RF	Access via I ² C	Default values	Description
Configuration register: WDT_MS					
7-0	WDT_MS	R&W	R&W	08h	Most Significant byte of watchdog time control register. When writing WDT_MS byte, the content of WDT_MS and WDT_LS gets active for the watchdog timer.
Configuration register: I2C_CLOCK_STR					
7-1	RFU	READ	READ	0...0b	reserved for future use, all 7 bits locked to 0b
0	I2C_CLOCK_STR	R&W	R&W	1b	Enables (1b) or disable (0b) the I ² C clock stretching
Configuration register: REG_LOCK					
7-2	RFU	READ	READ	000000b	reserved for future use, all 6 bits locked to 0b
1	REG_LOCK_I2C	R&W	R&W	0b	0b... Enable writing of the configuration bytes via I ² C 1b... Disable writing of the configuration bytes via I ² C Once set to 1b, cannot be reset to 0b anymore.
0	REG_LOCK_RF	R&W	R&W	0b	0b... Enable writing of the configuration bytes via RF 1b... Disable writing of the configuration bytes via RF Once set to 1b, cannot be reset to 0b anymore.

Table 14. Session register bytes

Bit	Field	Access via RF	Access via I ² C	Default values	Description
Session register: NC_REG					
7	I2C_RST_ON_OFF	READ	R&W	-	see configuration bytes description
6	PTHRU_ON_OFF	READ	R&W	0b	1b... enables data transfer via the SRAM buffer (Pass-through mode)
5	FD_OFF	READ	R&W	-	see configuration bytes description
4					
3	FD_ON	READ	R&W	-	see configuration bytes description
2					
1	SRAM_MIRROR_ON_OFF	READ	R&W	0b	1b enables SRAM mirroring
0	PTHRU_DIR	READ	R&W		see configuration bytes description
Session register: LAST_NDEF_BLOCK					
7-0	LAST_NDEF_BLOCK	READ	R&W	-	see configuration bytes description
Session register: SRAM_MIRROR_BLOCK					
7-0	SRAM_MIRROR_BLOCK	READ	R&W	-	see configuration bytes description
Session register: WDT_LS					
7-0	WDT_LS	READ	R&W	-	see configuration bytes description

Table 14. ...continued Session register bytes

Bit	Field	Access via RF	Access via I ² C	Default values	Description
Session register: WDT_MS					
7-0	WDT_MS	READ	R&W	-	see configuration bytes description
Session register: I2C_CLOCK_STR					
7-1	RFU	READ	READ	-	reserved for future use, all 7 bits locked to 0b
0	I2C_CLOCK_STR	READ	READ		See configuration bytes description
Session register: NS_REG					
7	NDEF_DATA_READ	READ	READ	0b	1b... all data bytes read from the address specified in LAST_NDEF_BLOCK. value is reset to 0b when read
6	I2C_LOCKED	READ	R&W	0b	1b... Memory access is locked to the I ² C interface
5	RF_LOCKED	READ	READ	0b	1b... Memory access is locked to the RF interface
4	SRAM_I2C_READY	READ	READ	0b	1b... data is ready in SRAM buffer to be read by I2C
3	SRAM_RF_READY	READ	READ	0b	1b... data is ready in SRAM buffer to be read by RF
2	EEPROM_WR_ERR	READ	R&W	0b	1b... HV voltage error during EEPROM write or erase cycle Needs to be written back via I ² C to 0b to be cleared
1	EEPROM_WR_BUSY	READ	READ	0b	1b... EEPROM write cycle in progress - access to EEPROM disabled 0b... EEPROM access possible
0	RF_FIELD_PRESENT	READ	READ	0b	1b... RF field is detected

8.4 Configurable Field Detection Pin

The field detection feature provides the capability to trigger an external device (e.g. μ Controller) or switch on the connected circuitry by an external power management unit depending on activities on the RF interface.

The conditions for the activation of the field detection signal (FD_ON) can be:

- The presence of the RF field
- The detection of a valid command (Start of Communication)
- The selection of the IC.

The conditions for the de-activation of the field detection signal (FD_OFF) can be:

- The absence of the RF field
- The detection of the HALT state
- The RF interface has read the last part of the NDEF message defined with LAST_NDEF_BLOCK

All the various combinations of configurations are described in [Table 13](#) and illustrated in [Figure 12](#), [Figure 13](#) and [Figure 14](#) for all various combination of the field detection signal configuration.

The field detection pin can also be used as a handshake mechanism in the Pass-through mode to signal to the external microcontroller if

- New data are written to SRAM on the RF interface
- Data written to SRAM from the microcontroller are read via the RF interface.

See [Section 11](#) for more information on this handshake mechanism.

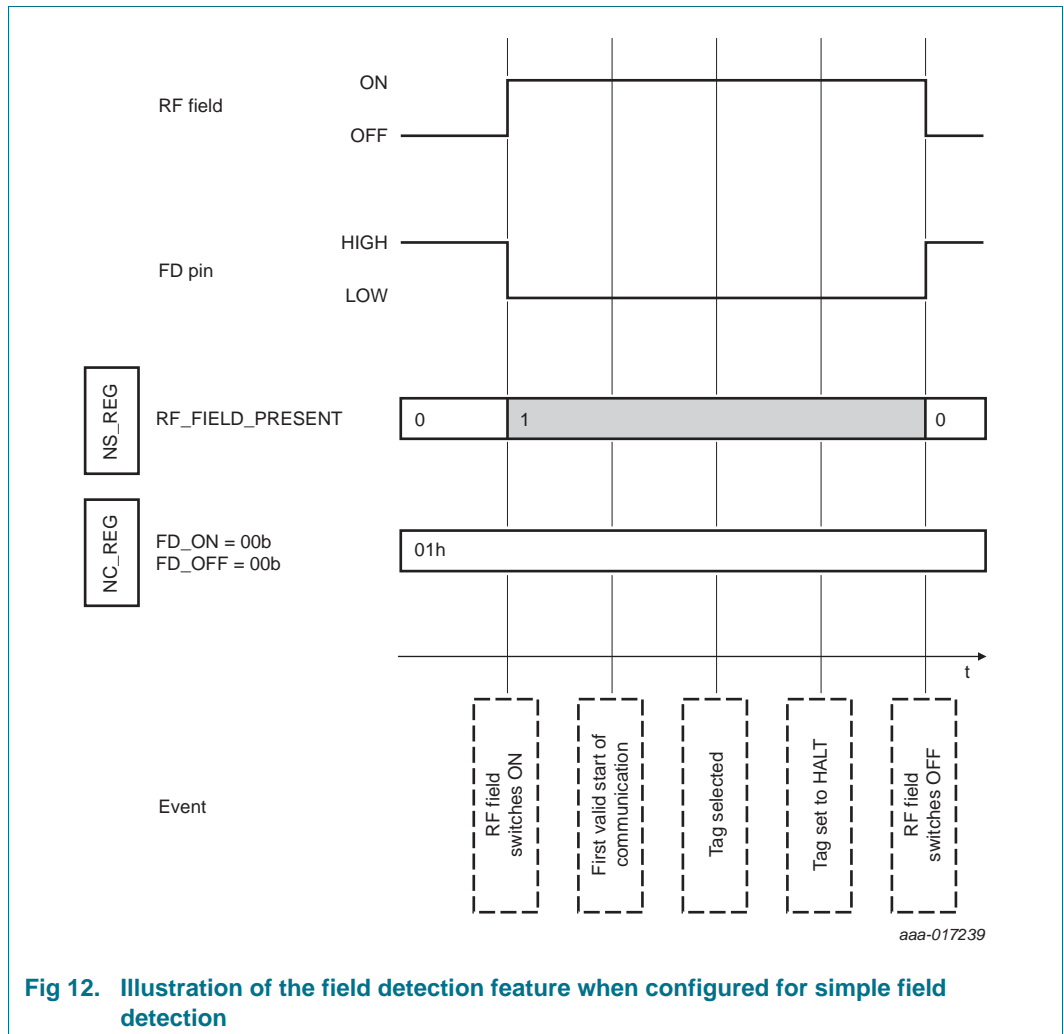

Fig 12. Illustration of the field detection feature when configured for simple field detection

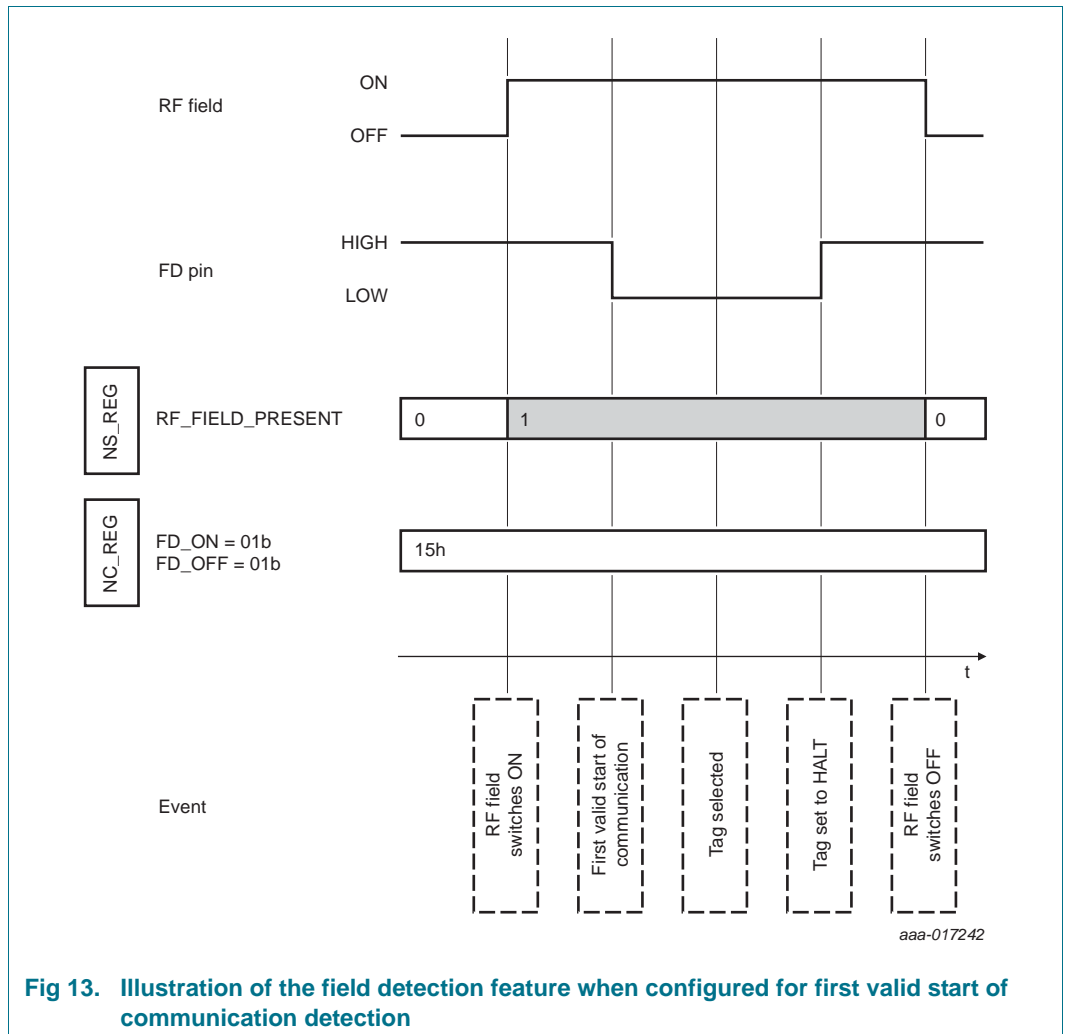

Fig 13. Illustration of the field detection feature when configured for first valid start of communication detection

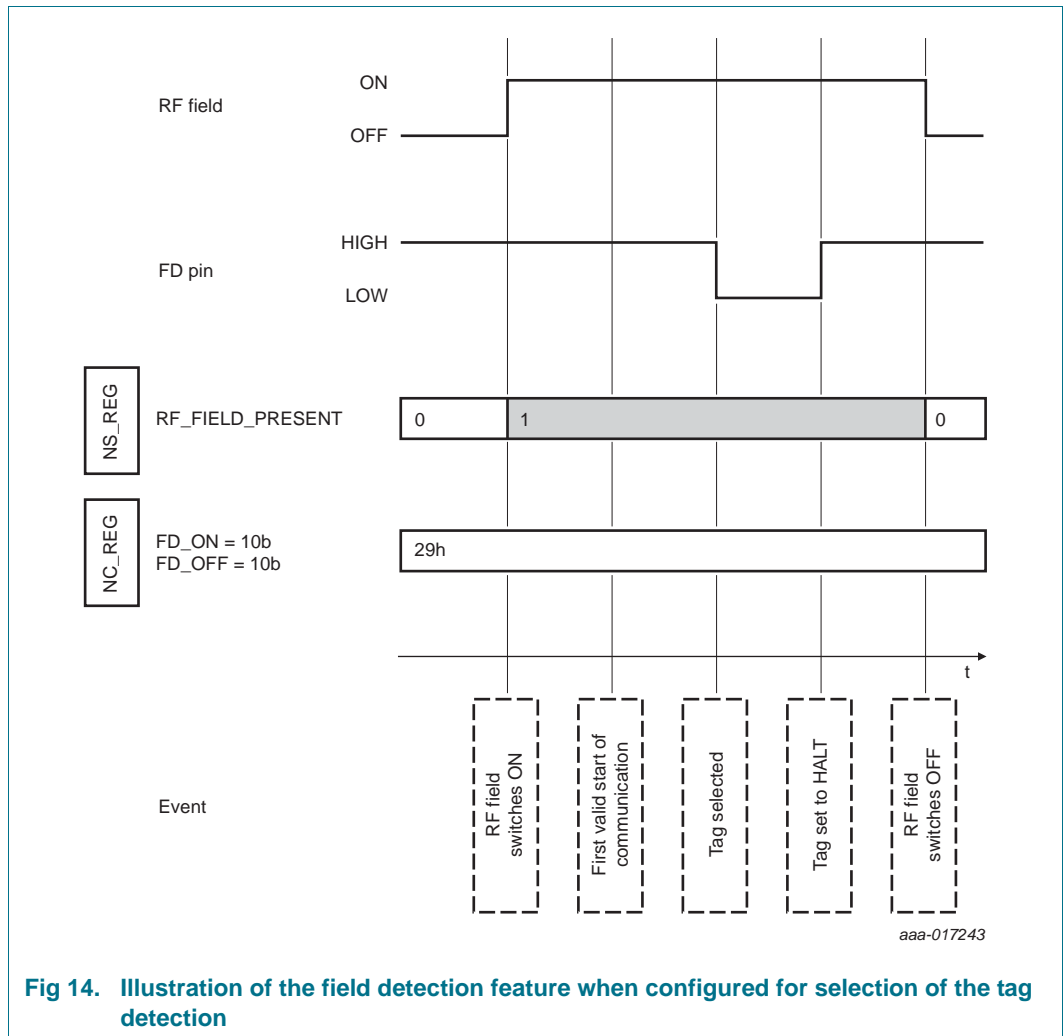

Fig 14. Illustration of the field detection feature when configured for selection of the tag detection

8.5 Watchdog timer

In order to allow the I²C interface to perform all necessary commands (READ, WRITE...), the memory access remains locked to the I²C interface until the register I2C_LOCKED is cleared by the host - see [Table 14](#).

In order however to avoid that the memory stays 'locked' to the I²C for a long period of time, it is possible to program a watchdog timer to unlock the I²C host from the tag, so that the RF reader can access the tag after a period of time of inactivity. The host itself will not be notified of this event directly, but the NS_REG register is updated accordingly (the register bit I2C_LOCKED will be cleared - see [Table 14](#)).

The default value is set to 20 ms (848h), but the watch dog timer can be freely set from 0001h (9.43 μ s) up to FFFFh (617.995 ms). The timer starts ticking when the communication between the NTAG I²C and the I²C interface starts. In case the communication with the I²C is still going on after the watchdog timer expires, the communication will continue until the communication has completed. Then the status register I2C_LOCKED will be immediately cleared.

In the case where the communication with the I²C interface has completed before the end of the timer and the status register I2C_LOCKED was not cleared by the host, it will be cleared at the end of the watchdog timer.

The watchdog timer is only effective if the VCC pin is powered and will be reset and stopped if the NTAG I²C is not VCC powered or if the register status I2C_LOCKED is set to 0b and RF_LOCKED is set to 1b.

8.6 Energy harvesting

The NTAG I²C provides the capability to supply external low power devices with energy generated from the RF field of a NFC device.

The voltage and current from the energy harvesting depend on various parameters, such as the strength of the RF field, the tag antenna size, or the distance from the NFC device. At room temperature, NTAG I²C could provide typically 5 mA at 2 V on the VOUT pin with an NFC Phone.

Operating NTAG I²C in energy harvesting mode requires a number of precautions:

- A significant capacitor is needed to guarantee operation during RF communication. The total capacitor between VOUT and GND shall be in the range of 150nF to 200 nF.
- If NTAG I²C also powers the I²C bus, then VCC must be connected to VOUT, and pull-up resistors on the SCL and SDA pins must be sized to control SCL and SDA sink current when those lines are pulled low by NTAG I²C or the I²C host
- If NTAG I²C also powers the Field Detect bus, then the pull-up resistor on the Field Detect line must be sized to control the sink current into the Field Detect pin when NTAG I²C pulls it low
- The NFC reader device communicating with NTAG I²C shall apply polling cycles including an RF Field Off condition of at least 5.1 ms as defined in NFC Forum Activity specification (see [Ref. 4](#), chapter 6).

Note that increasing the output current on the V_{out} decreases the RF communication range.

9. I²C commands

For details about I²C interface refer to [Ref. 3](#).

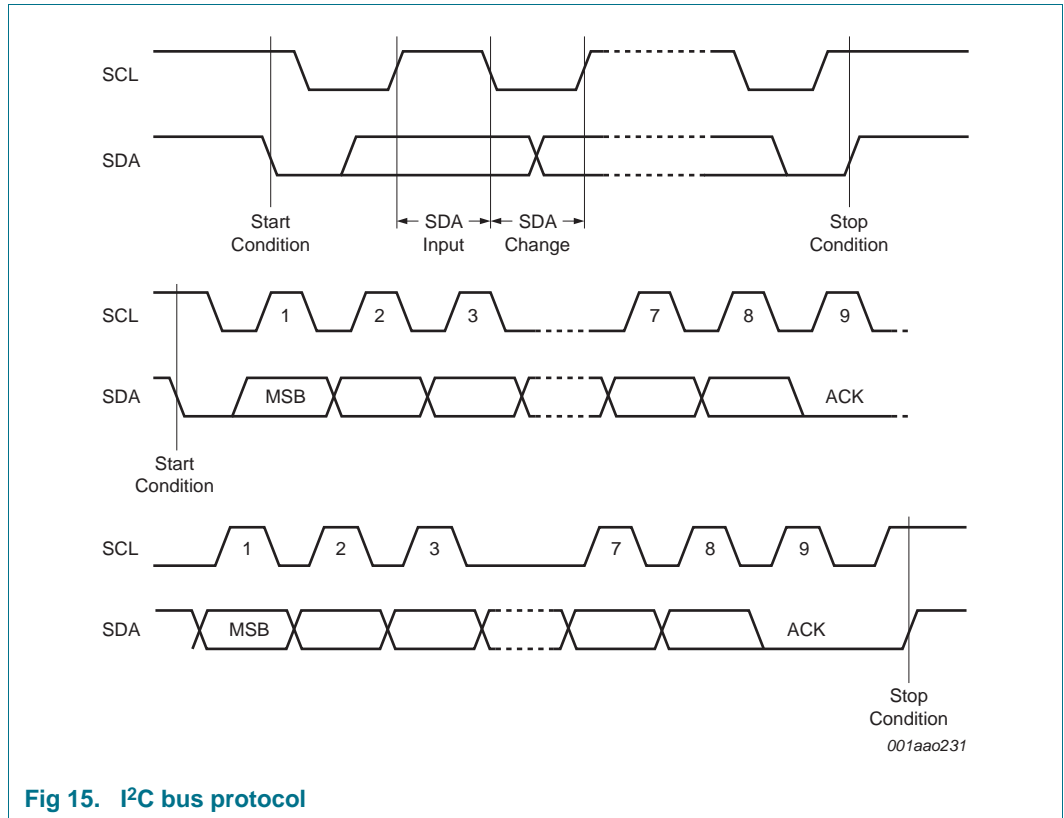

Fig 15. I²C bus protocol

The NTAG I²C supports the I²C protocol. This protocol is summarized in [Figure 15](#). Any device that sends data onto the bus is defined as a transmitter, and any device that reads the data from the bus is defined as a receiver. The device that controls the data transfer is known as the “bus master”, and the other as the “slave” device. A data transfer can only be initiated by the bus master, which will also provide the serial clock for synchronization. The NTAG I²C is always a slave in all communications.

9.1 Start condition

Start is identified by a falling edge of Serial Data (SDA), while Serial Clock (SCL) is stable in the high state. A Start condition must precede any data transfer command. The NTAG I²C continuously monitors SDA (except during a Write cycle) and SCL for a Start condition, and will not respond unless one is given.

9.2 Stop condition

Stop is identified by a rising edge of SDA while SCL is stable and driven high. A Stop condition terminates communication between the NTAG I²C and the bus master. A Stop condition at the end of a Write command triggers the internal Write cycle.

9.3 Soft reset feature

In the case where the I²C interface is constantly powered on, NTAG I²C can trigger a reset of the I²C interface via its soft reset feature- see [Table 13](#).

When this feature is enabled, if the microcontroller does not issue a stop condition between two start conditions, this situation will trigger a reset of the I²C interface and hence may hamper the communication via the I²C interface.

9.4 Acknowledge bit (ACK)

The acknowledge bit is used to indicate a successful byte transfer. The bus transmitter, whether it is the bus master or slave device, releases Serial Data (SDA) after sending eight bits of data. During the 9th clock pulse period, the receiver pulls Serial Data (SDA) low to acknowledge the receipt of the eight data bits.

9.5 Data input

During data input, the NTAG I²C samples SDA on the rising edge of SCL. For correct device operation, SDA must be stable during the rising edge of SCL, and the SDA signal must change only when SCL is driven low.

9.6 Addressing

To start communication between a bus master and the NTAG I²C slave device, the bus master must initiate a Start condition. Following this initiation, the bus master sends the device address. The NTAG I²C address from I²C consists of a 7-bit device identifier (see [Table 15](#) for default value).

The 8th bit is the Read/Write bit (RW). This bit is set to 1 for Read and 0 for Write operations.

If a match occurs on the device address, the NTAG I²C gives an acknowledgment on SDA during the 9th bit time. If the NTAG I²C does not match the device select code, it deselects itself from the bus and clear the register I2C_LOCKED (see [Table 12](#)).

Table 15. Default NTAG I²C address from I²C

	Device address							R/W
	b7	b6	b5	b4	b3	b2	b1	
Value	1 ^[1]	0 ^[1]	1 ^[1]	0 ^[1]	1 ^[1]	0 ^[1]	1 ^[1]	1/0

[1] Initial values - can be changed.

The I²C address of the NTAG I²C (byte 0 - block 0h) can only be modified by the I²C interface. Both interfaces have no READ access to this address and a READ command from the RF or I²C interface to this byte will only return 04h (manufacturer ID for NXP Semiconductors - see [Figure 6](#)).

9.7 READ and WRITE Operation

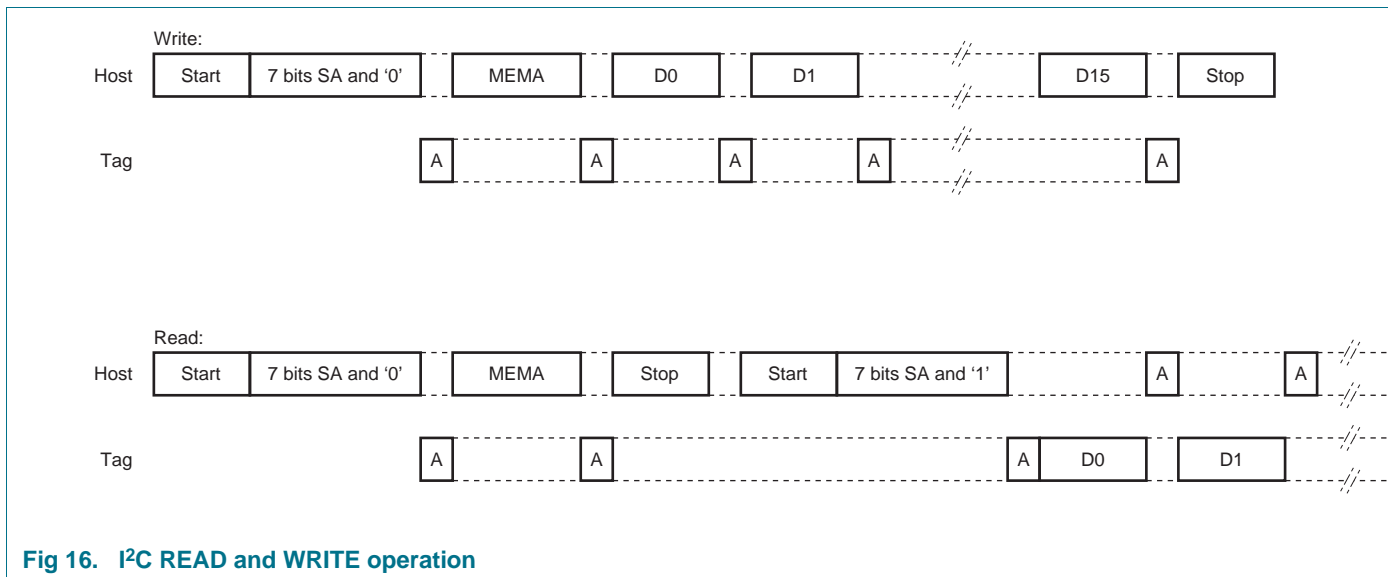

Fig 16. I²C READ and WRITE operation

The READ and WRITE operation handle always 16 bytes to be read or written (one block - see [Table 7](#))

For the READ operation (see [Figure 16](#)), following a Start condition, the bus master/host sends the NTAG I²C slave address code (SA - 7 bits) with the Read/Write bit (RW) reset to 0. The NTAG I²C acknowledges this (A), and waits for one address byte (MEMA), which should correspond to the address of the block of memory (SRAM or EEPROM) that is intended to be read. The NTAG I²C responds to a valid address byte with an acknowledge (A). A Stop condition can be then issued. Then the host again issues a start condition followed by the NTAG I²C slave address with the Read/Write bit set to 1b. When I2C_CLOCK_STR is set to 0b, a pause of at least 50 μ s shall be kept before this start condition. The NTAG I²C acknowledges this (A) and sends the first byte of data read (D0). The bus master/host acknowledges it (A) and the NTAG I²C will subsequently transmit the following 15 bytes of memory read with an acknowledge from the host after every byte. After the last byte of memory data has been transmitted by the NTAG I²C, the bus master/host will acknowledge it and issue a Stop condition.

For the WRITE operation (see [Figure 16](#)), following a Start condition, the bus master/host sends the NTAG I²C slave address code (SA - 7 bits) with the Read/Write bit (RW) reset to 0. The NTAG I²C acknowledges this (A), and waits for one address byte (MEMA), which should correspond to the address of the block of memory (SRAM or EEPROM) that is intended to be written. The NTAG I²C responds to a valid address byte with an acknowledge (A) and, in the case of a WRITE operation, the bus master/host starts transmitting each 16 bytes (D0...D15) that shall be written at the specified address with an acknowledge of the NTAG I²C after each byte (A). After the last byte acknowledge from the NTAG I²C, the bus master/host issues a Stop condition.

The memory address accessible via the READ and WRITE operations can only correspond to the EEPROM or SRAM (respectively 00h to 3Ah or F8h to FBh for NTAG I²C 1k and 00h to 7Ah or F8h to FBh for NTAG I²C 2k).

9.8 WRITE and READ register operation

In order to modify or read the session register bytes (see [Table 14](#)), NTAG I²C requires the WR operation (see [Figure 17](#)).

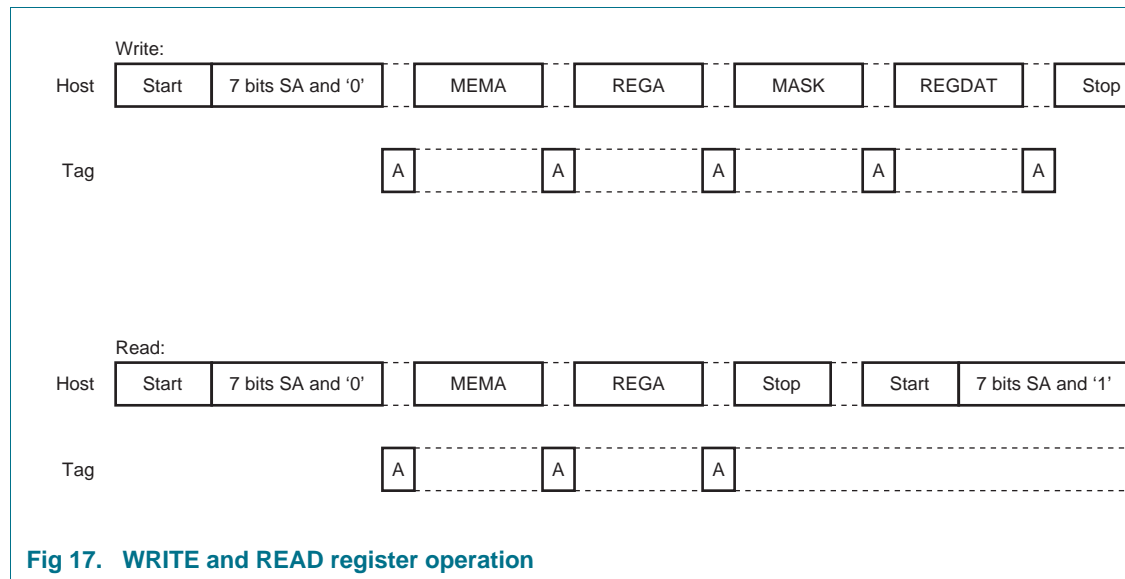

Fig 17. WRITE and READ register operation

For the READ register operation, following a Start condition the bus master/host sends the NTAG I²C slave address code (SA - 7 bits) with the Read/Write bit (RW) reset to 0. The NTAG I²C acknowledges this (A), and waits for one address byte (MEMA) which corresponds to the address of the block of memory with the session register bytes (FEh). The NTAG I²C responds to the address byte with an acknowledge (A). Then the bus master/host issues a register address (REGA), which corresponds to the address of the targeted byte inside the block FEh (00h, 01h...to 07h) and then waits for the Stop condition.

Then the bus master/host again issues a start condition followed by the NTAG I²C slave address with the Read/Write bit set to 1b. The NTAG I²C acknowledges this (A), and sends the selected byte of session register data (REGDAT) within the block FEh. The bus master/host will acknowledge it and issue a Stop condition.

For the WRITE register operation, following a Start condition, the bus master/host sends the NTAG I²C slave address code (SA - 7 bits) with the Read/Write bit (RW) reset to 0. The NTAG I²C acknowledges this (A), and waits for one address byte (MEMA), which corresponds to the address of the block of memory within the session register bytes (FEh). After the NTAG I²C acknowledge (A), the bus master/host issues a register address (REGA), which corresponds to the address of the targeted byte inside the block FEh (00h, 01h...to 07h). After acknowledgement (A) by NTAG I²C, the bus master/host issues a MASK byte that defines exactly which bits shall be modified by a 1b bit value at the corresponding bit position. Following the NTAG I²C acknowledge (A), the new register data (one byte - REGDAT) to be written is transmitted by the bus master/host. The NTAG I²C acknowledges it (A), and the bus master/host issues a stop condition.

10. RF Command

NTAG activation follows the ISO/IEC 14443 Type A specification. After NTAG I²C has been selected, it can either be deactivated using the ISO/IEC 14443 HALT command, or NTAG commands (e.g., READ or WRITE) can be performed. For more details about the card activation refer to [Ref. 2](#).

10.1 NTAG I²C command overview

All available commands for NTAG I²C are shown in [Table 16](#).

Table 16. Command overview

Command ^[1]	ISO/IEC 14443	NFC FORUM	Command code (hexadecimal)
Request	REQA	SENS_REQ	26h (7 bit)
Wake-up	WUPA	ALL_REQ	52h (7 bit)
Anticollision CL1	Anticollision CL1	SDD_REQ CL1	93h 20h
Select CL1	Select CL1	SEL_REQ CL1	93h 70h
Anticollision CL2	Anticollision CL2	SDD_REQ CL2	95h 20h
Select CL2	Select CL2	SEL_REQ CL2	95h 70h
Halt	HLTA	SLP_REQ	50h 00h
GET_VERSION	-	-	60h
READ	-	READ	30h
FAST_READ	-	-	3Ah
WRITE	-	WRITE	A2h
SECTOR_SELECT		SECTOR_SELECT	C2h

[1] Unless otherwise specified, all commands use the coding and framing as described in [Ref. 1](#).

10.2 Timing

The command and response timing shown in this document are not to scale and values are rounded to 1 μ s.

All given command and response times refer to the data frames, including start of communication and end of communication. They do not include the encoding (like the Miller pulses). An NFC device data frame contains the start of communication (1 "start bit") and the end of communication (one logic 0 + 1 bit length of unmodulated carrier). An NFC tag data frame contains the start of communication (1 "start bit") and the end of communication (1 bit length of no subcarrier).

The minimum command response time is specified according to [Ref. 1](#) as an integer n , which specifies the NFC device to NFC tag frame delay time. The frame delay time from NFC tag to NFC device is at least 87 μ s. The maximum command response time is specified as a time-out value. Depending on the command, the T_{ACK} value specified for command responses defines the NFC device to NFC tag frame delay time. It does it for either the 4-bit ACK value specified or for a data frame.

All timing can be measured according to the ISO/IEC 14443-3 frame specification as shown for the Frame Delay Time in [Figure 18](#). For more details refer to [Ref. 2](#).

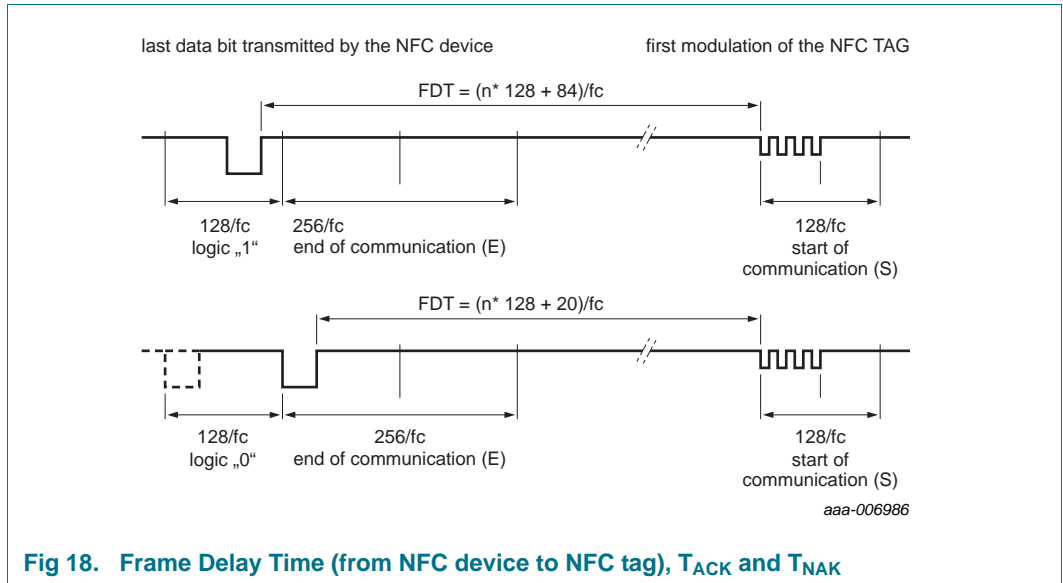

Remark: Due to the coding of commands, the measured timings usually excludes (a part of) the end of communication. Consider this factor when comparing the specified with the measured times.

10.3 NTAG ACK and NAK

NTAG uses a 4 bit ACK / NAK as shown in [Table 17](#).

Table 17. ACK and NAK values

Code (4-bit)	ACK/NAK
Ah	Acknowledge (ACK)
0h	NAK for invalid argument (i.e. invalid page address)
1h	NAK for parity or CRC error
3h	NAK for Arbiter locked to I ² C
7h	NAK for EEPROM write error

10.4 ATQA and SAK responses

NTAG I²C replies to a REQA or WUPA command with the ATQA value shown in [Table 18](#). It replies to a Select CL2 command with the SAK value shown in [Table 19](#). The 2-byte ATQA value is transmitted with the least significant byte first (44h).

Table 18. ATQA response of the NTAG I²C

Sales type	Hex value	Bit number																
		16	15	14	13	12	11	10	9	8	7	6	5	4	3	2	1	
NTAG I ² C	00 44h	0	0	0	0	0	0	0	0	0	0	1	0	0	0	1	0	0

Table 19. SAK response of the NTAG I²C

Sales type	Hex value	Bit number							
		8	7	6	5	4	3	2	1
NTAG I ² C	00h	0	0	0	0	0	0	0	0

Remark: The ATQA coding in bits 7 and 8 indicate the UID size according to ISO/IEC 14443 independent from the settings of the UID usage.

Remark: The bit numbering in the ISO/IEC 14443 specification starts with LSB = bit 1 and not with LSB = bit 0. So 1 byte counts bit 1 to bit 8 instead of bit 0 to bit 7.

10.5 GET_VERSION

The GET_VERSION command is used to retrieve information about the NTAG family, the product version, storage size and other product data required to identify the specific NTAG I²C.

This command is also available on other NTAG products to have a common way of identifying products across platforms and evolution steps.

The GET_VERSION command has no arguments and returns the version information for the specific NTAG I²C type. The command structure is shown in [Figure 19](#) and [Table 20](#).

[Table 21](#) shows the required timing.

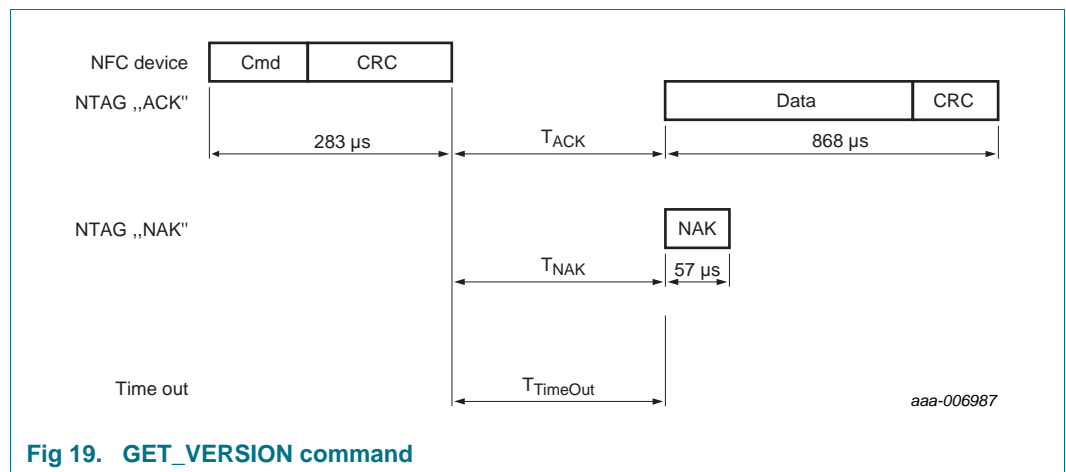

Fig 19. GET_VERSION command

Table 20. GET_VERSION command

Name	Code	Description	Length
Cmd	60h	Get product version	1 byte
CRC	-	CRC according to Ref. 1	2 bytes
Data	-	Product version information	8 bytes
NAK	see Table 17	see Section 10.3	4-bit

Table 21. GET_VERSION timing

These times exclude the end of communication of the NFC device.

	T _{ACK/NAK min}	T _{ACK/NAK max}	T _{TimeOut}
GET_VERSION	n=9 ^[1]	T _{TimeOut}	5 ms

[1] Refer to [Section 10.2 "Timing"](#).

Table 22. GET_VERSION response for NTAG I²C 1k and 2k

Byte no.	Description	NTAG I ² C 1k	NTAG I ² C 2k	Interpretation
0	fixed Header	00h	00h	
1	vendor ID	04h	04h	NXP Semiconductors
2	product type	04h	04h	NTAG
3	product subtype	05h	05h	50 pF I ² C, Field detection
4	major product version	02h	02h	2
5	minor product version	01h	01h	V1
6	storage size	13h	15h	see following information
7	protocol type	03h	03h	ISO/IEC 14443-3 compliant

The most significant 7 bits of the storage size byte are interpreted as an unsigned integer value n. As a result, it codes the total available user memory size as 2ⁿ. If the least significant bit is 0b, the user memory size is exactly 2ⁿ. If the least significant bit is 1b, the user memory size is between 2ⁿ and 2ⁿ⁺¹.

The user memory for NTAG I²C 1k is 888 bytes. This memory size is between 512 bytes and 1024 bytes. Therefore, the most significant 7 bits of the value 13h, are interpreted as 9d, and the least significant bit is 1b.

The user memory for NTAG I²C 2k is 1904 bytes. This memory size is between 1024 bytes and 2048 bytes. Therefore, the most significant 7 bits of the value 15h, are interpreted as 10d, and the least significant bit is 1b.

10.6 READ

The READ command requires a start page address, and returns the 16 bytes of four NTAG I²C pages. For example, if address (Addr) is 03h then pages 03h, 04h, 05h, 06h are returned. Special conditions apply if the READ command address is near the end of the accessible memory area. For details on those cases and the command structure refer to [Figure 20](#) and [Table 23](#).

[Table 24](#) shows the required timing.

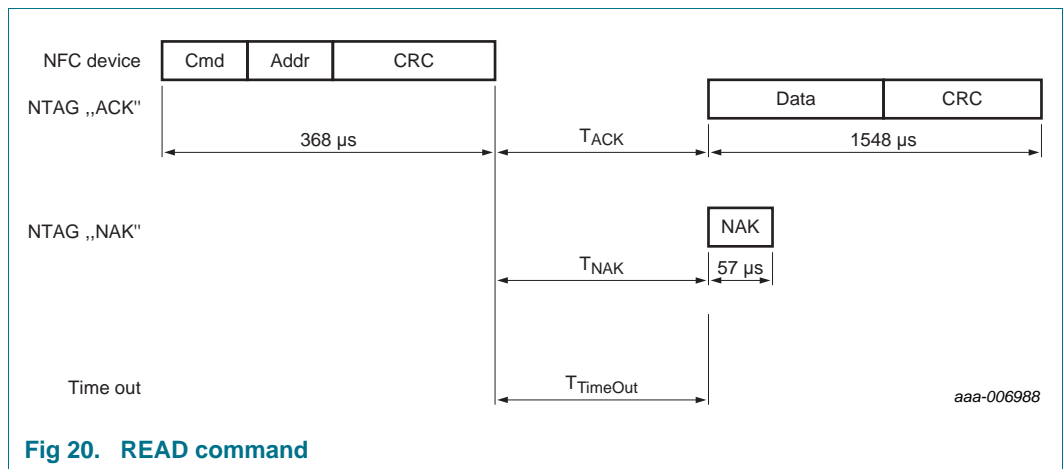

Fig 20. READ command

Table 23. READ command

Name	Code	Description	Length
Cmd	30h	read four pages	1 byte
Addr	-	start page address	1 byte
CRC	-	CRC according to Ref. 1	2 bytes
Data	-	Data content of the addressed pages	16 bytes
NAK	see Table 17	see Section 10.3	4-bit

Table 24. READ timing

These times exclude the end of communication of the NFC device.

	T _{ACK/NAK min}	T _{ACK/NAK max}	T _{TimeOut}
READ	n=9 ^[1]	T _{TimeOut}	5 ms

[1] Refer to [Section 10.2 "Timing"](#).

In the initial state of NTAG I²C, all memory pages are allowed as Addr parameter to the READ command:

- Page address from 00h to E2h and E8h for NTAG I²C 1k
- Page address from 00h to FFh (sector 0), from page 00h to E0h and E8h (sector 1) for NTAG I²C 2k
- SRAM buffer address when Pass-through mode is enabled

Addressing a start memory page beyond the limits above results in a NAK response from NTAG I²C.

In case a READ command addressing start with a valid memory area but extends over an invalid memory area, the content of the invalid memory area will be reported as 00h.

10.7 FAST_READ

The FAST_READ command requires a start page address and an end page address and returns all n*4 bytes of the addressed pages. For example, if the start address is 03h and the end address is 07h, then pages 03h, 04h, 05h, 06h and 07h are returned.

For details on those cases and the command structure, refer to [Figure 21](#) and [Table 25](#).

[Table 26](#) shows the required timing.

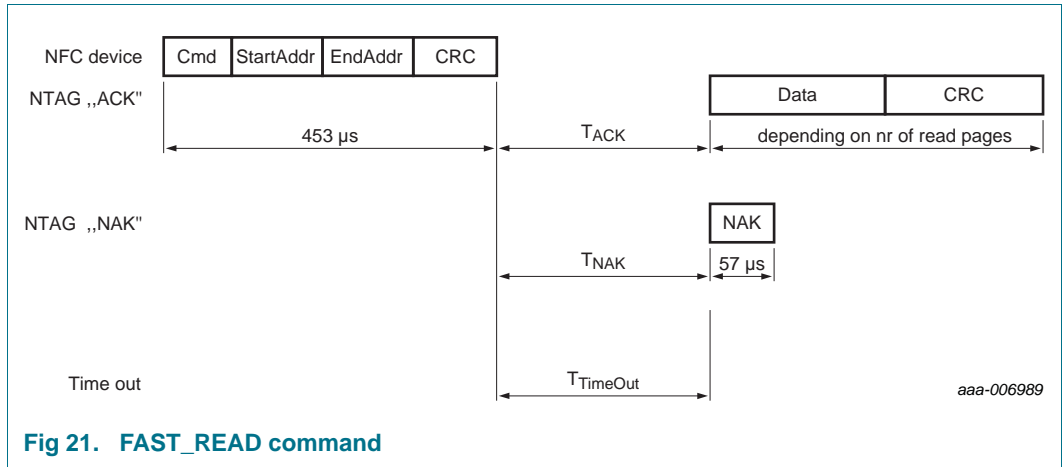

Table 25. FAST_READ command

Name	Code	Description	Length
Cmd	3Ah	read multiple pages	1 byte
StartAddr	-	start page address	1 byte
EndAddr	-	end page address	1 byte
CRC	-	CRC according to Ref. 1	2 bytes
Data	-	data content of the addressed pages	n*4 bytes
NAK	see Table 17	see Section 10.3	4-bit

Table 26. FAST_READ timing

These times exclude the end of communication of the NFC device.

	T _{ACK/NAK min}	T _{ACK/NAK max}	T _{TimeOut}
FAST_READ	n=9 ^[1]	T _{TimeOut}	5 ms

[1] Refer to [Section 10.2 "Timing"](#).

In the initial state of NTAG I²C, all memory pages are allowed as StartAddr parameter to the FAST_READ command:

- Page address from 00h to E2h and E8h for NTAG I²C 1k
- Page address from 00h to FFh (sector 0), from page 00h to E0h and E8h (sector 1) for NTAG I²C 2k
- SRAM buffer address when Pass-through mode is enabled

If the start addressed memory page (StartAddr) is outside of accessible area, NTAG I²C replies a NAK.

In case the FAST_READ command starts with a valid memory area but extends over an invalid memory area, the content of the invalid memory area will be reported as 00h.

The EndAddr parameter must be equal to or higher than the StartAddr.

Remark: The FAST_READ command is able to read out the entire memory of one sector with one command. Nevertheless, the receive buffer of the NFC device must be able to handle the requested amount of data as no chaining is possible.

10.8 WRITE

The WRITE command requires a block address, and writes 4 bytes of data into the addressed NTAG I²C page. The WRITE command is shown in [Figure 22](#) and [Table 27](#).

[Table 28](#) shows the required timing.

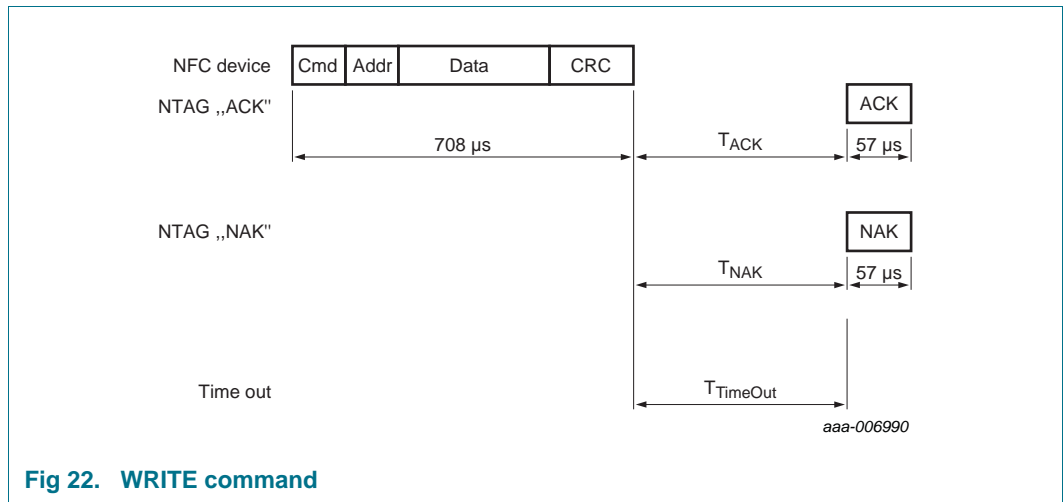

Fig 22. WRITE command

Table 27. WRITE command

Name	Code	Description	Length
Cmd	A2h	write one page	1 byte
Addr	-	page address	1 byte
CRC	-	CRC according to Ref. 1	2 bytes
Data	-	data	4 bytes
NAK	see Table 17	see Section 10.3	4-bit

Table 28. WRITE timing

These times exclude the end of communication of the NFC device.

	T _{ACK/NAK min}	T _{ACK/NAK max}	T _{TimeOut}
WRITE	n=9 ^[1]	T _{TimeOut}	10 ms

[1] Refer to [Section 10.2 "Timing"](#).

In the initial state of NTAG I²C, the following memory pages are valid Addr parameters to the WRITE command:

- Page address from 02h to E2h, E8h and E9h (sector 0) for NTAG I²C 1k
- Page address from 02h to FFh (sector 0), from 00h to E0h, E8h and E9h (sector 1) for NTAG I²C 2k
- SRAM buffer addresses when Pass-through mode is enabled

Addressing a memory page beyond the limits above results in a NAK response from NTAG I²C.

Pages that are locked against writing cannot be reprogrammed using any write command. The locking mechanisms include static and dynamic lock bits, as well as the locking of the configuration pages.

10.9 SECTOR SELECT

The SECTOR SELECT command consists of two commands packet: the first one is the SECTOR SELECT command (C2h), FFh and CRC. Upon an ACK answer from the Tag, the second command packet needs to be issued with the related sector address to be accessed and 3 bytes RFU.

To successfully access to the requested memory sector, the tag shall issue a passive ACK, which is sending NO REPLY for more than 1ms after the CRC of the second command set.

The SECTOR SELECT command is shown in [Figure 23](#) and [Table 29](#).

[Table 30](#) shows the required timing.

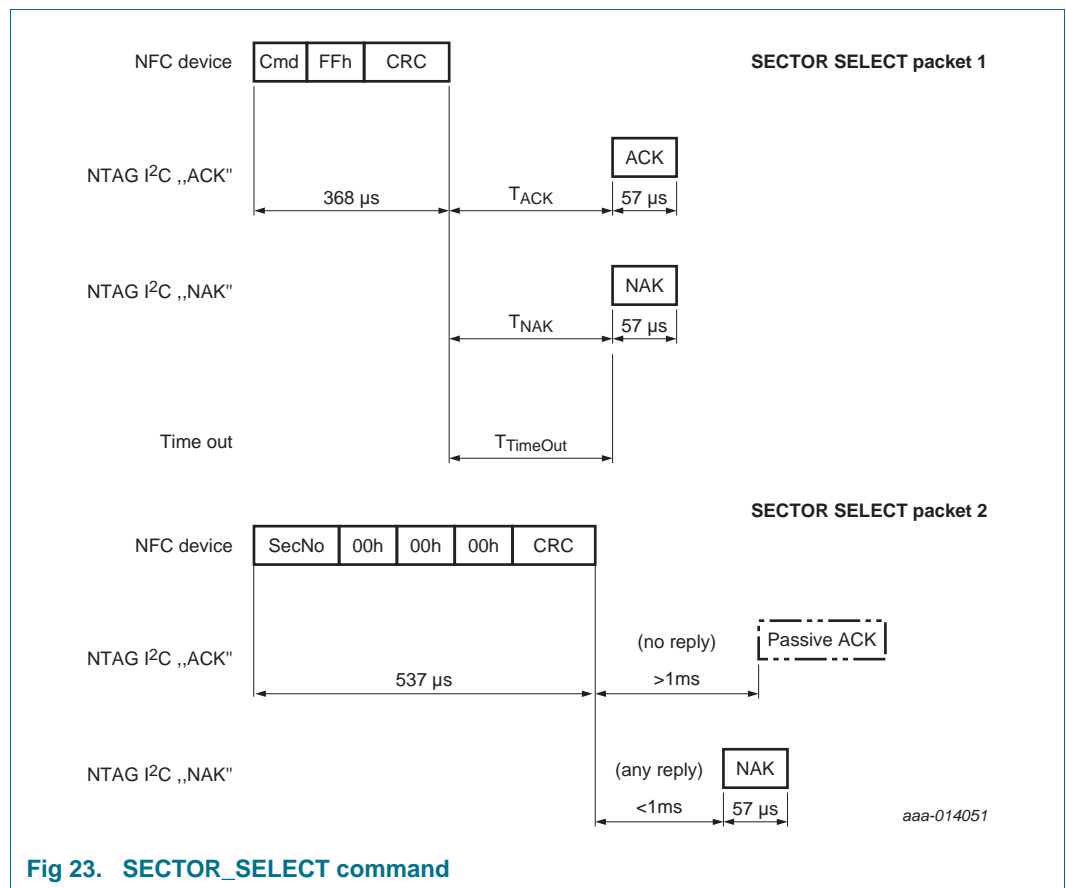

Fig 23. SECTOR_SELECT command

Table 29. SECTOR_SELECT command

Name	Code	Description	Length
Cmd	C2h	sector select	1 byte
FFh	-		1 byte
CRC	-	CRC according to Ref. 1	2 bytes
SecNo	-	Memory sector to be selected (00h-FEh)	1 byte
NAK	see Table 17	see Section 10.3	4-bit

Table 30. SECTOR_SELECT timing

These times exclude the end of communication of the NFC device.

	T _{ACK/NAK min}	T _{ACK/NAK max}	T _{TimeOut}
SECTOR SELECT	n=9 ^[1]	T _{TimeOut}	10 ms

[1] Refer to [Section 10.2 "Timing"](#).

11. Communication and arbitration between RF and I²C interface

If both interfaces are powered by their corresponding source, only one interface shall have access according to the "first-come, first-serve" principle.

In NS_REG, the two status bits I2C_LOCKED and RF_LOCKED reflect the status of the NTAG I²C memory access and indicate which interface is locking the memory access. At power on, both bits are 0, setting the arbitration in idle mode.

In the case arbiter locks to the I²C interface, an RF reader still can access the session registers. If the ISO state machine is in ACTIVE state, only the SECTOR SELECT command is allowed. But any other command requiring EEPROM access like READ or WRITE is handled as an illegal command and replied to with a special NAK value.

In the case where the memory access is locked to the RF interface, the I²C host still can access the NFC register, by issuing a 'Register READ/WRITE' command. All other read or write commands will be replied to with a NACK to the I²C host.

11.1 Non-Pass-through mode

PTHRU_ON_OFF = 0b (see [Table 14](#)) indicates non-Pass-through mode.

11.1.1 I²C interface access

If the tag is in the IDLE or HALT state (RF state after POR or HALT-command) and the correct I²C slave address of NTAG I²C is specified following the START condition, the bit I2C_LOCKED will be automatically set to 1b. If I2C_LOCKED = 1b, the I²C interface has access to the tag memory and the tag will respond with a NACK to any memory READ/WRITE command on the RF interface other than reading the register bytes command during this time.

I2C_LOCKED must be either reset to 0b at the end of the I²C sequence or wait until the end of the watch dog timer.

11.1.2 RF interface access

The arbitration will allow the RF interface read and write accesses to EEPROM only when I2C_LOCKED is set to 0b.

RF_LOCKED is automatically set to 1b if the tag receives a valid command (EEPROM Access Commands) on the RF interface. If RF_LOCKED = 1b, the tag is locked to the RF interface and will not respond to any command from the I²C interface other than READ register command (see [Table 14](#)).

RF_LOCKED is automatically set to 0b in one of the following conditions

- At POR or if the RF field is switched off
- If the tag is set to the HALT state with a HALT command on the RF interface
- If the memory access command is finished on the RF interface

When the RF interface has read the last page of the NDEF message specified in LAST_NDEF_BLOCK (see [Table 13](#) and [Table 14](#)) the bit NDEF_DATA_READ - in the register NS_REG see [Table 14](#) - is set to 1b and indicates to the I²C interface that, for example, new NDEF data can be written.

11.2 SRAM buffer mapping with Memory Mirror enabled

With SRAM_MIRROR_ON_OFF= 1b, the SRAM buffer mirroring is enabled. This mode cannot be combined with the Pass-through mode (see [Section 11.3](#)).

With the memory mirror enabled, the SRAM is now mapped into the user memory from the RF interface perspective using the SRAM mirror lower page address specified in SRAM_MIRROR_BLOCK byte ([Table 13](#) and [Table 14](#)). See [Table 31](#) (NTAG I²C 1k) and [Table 32](#) (NTAG I²C 2k) for an illustration of this SRAM memory mapping when SRAM_MIRROR_BLOCK is set to 01h. The SRAM buffer will be then available in two locations: inside the user memory and at the end of the first or second memory sector (respectively NTAG I²C 1k or NTAG I²C 2k).

The tag must be VCC powered to make this mode work, because without VCC, the SRAM will not be accessible via RF powered only.

When mapping the SRAM buffer to the user memory, the user shall be aware that all data written into the SRAM part of the user memory will be lost once the NTAG I²C is no longer powered from the I²C side (as SRAM is a volatile memory).

Table 31. Illustration of the SRAM memory addressing via the RF interface (with SRAM_MIRROR_ON_OFF set to 1b and SRAM_MIRROR_BLOCK set to 01h) for the NTAG I²C 1k

Sector address	Page address		Byte number within a page				Access conditions
	Dec.	Hex.	0	1	2	3	
0	0	00h	Serial number				READ
	1	01h	Serial number			Internal	READ
	2	02h	Internal		Static lock bytes		READ/R&W
	3	03h	Capability Container (CC)				READ&WRITE
	4	04h	SRAM memory (16 blocks)				READ&WRITE
					
	19	13h					
	User memory				READ&WRITE
	225	E1h					
	226	E2h	Dynamic lock bytes			00h	R&W/READ
	227	E3h	Invalid access - returns NAK				n.a.
	228	E4h					
	229	E5h					
	230	E6h					
	231	E7h					
	232	E8h	Configuration registers				see 8.3.11
	233	E9h					
	234	EAh					
...	...	Invalid access - returns NAK				n.a.	
255	FFh						
1	Invalid access - returns NAK				n.a.
2	Invalid access - returns NAK				n.a.
3	0	00h	Invalid access - returns NAK				n.a.
					
	248	F8h	Session registers				see 8.3.11
	249	F9h					
	Invalid access - returns NAK				n.a.
255	FFh						

Table 32. Illustration of the SRAM memory addressing via the RF interface (with SRAM_MIRROR_ON_OFF set to 1b and SRAM_MIRROR_BLOCK set to 01h) for the NTAG I²C 2k

Sector address	Page address		Byte number within a page				Access conditions				
	Dec.	Hex.	0	1	2	3					
0	0	00h	Serial number				READ				
	1	01h	Serial number			Internal	READ				
	2	02h	Internal		Static lock bytes		READ/R&W				
	3	03h	Capability Container (CC)				READ&WRITE				
	4	04h	SRAM memory (16 blocks)				READ&WRITE				
									
	19	13h									
	User memory				READ&WRITE				
	255	FFh									
1	0	...									
	1	...									
									
									
	223	DFh									
	224	E0h						Dynamic lock bytes		00h	R&W/READ
	225	E1h						Invalid access - returns NAK			
	226	E2h									
	227	E3h									
	228	E4h									
	229	E5h									
	230	E6h									
	231	E7h									
	232	E8h	Configuration registers				see 8.3.11				
	233	E9h									
	234	EAh									
	Invalid access - returns NAK				n.a.				
255	FFh										
2	Invalid access - returns NAK				n.a.				
3	0	00h	Invalid access - returns NAK				n.a.				
									
	248	F8h	Session registers				see 8.3.11				
	249	F9h									
	Invalid access - returns NAK				n.a.				
255	FFh										

11.3 Pass-through mode

PTHRU_ON_OFF = 1b (see [Table 14](#)) enables and indicates Pass-through mode.

To handle large amount of data transfer from one interface to the other, NTAG I²C offers the Pass-through mode where data is transferred via a 64 byte SRAM buffer. This buffer offers fast write access and unlimited write endurance as well as an easy handshake mechanism between the two interfaces.

This buffer is mapped directly at the end of the sector 0 (NTAG I²C 1k) or sector 1 (NTAG I²C 2k) of the memory (from the RF interface perspective).

In both cases, the principle of access to the SRAM buffer via the RF and I²C interface is exactly the same (see [Section 11.3.2](#) and [Section 11.3.3](#)).

The data flow direction must be set with the PTHRUDIR bit (see [Table 14](#)) within the current communication session with the session registers (in this case, it can only be set via the I²C interfaces) or for the configuration bits after POR (in this case both RF and I²C interface can set it). This Pass-through direction settings avoids locking the memory access during the data transfer from one interface to the SRAM buffer.

The Pass-through mode can only be enabled via I²C interface when both interfaces are powered. The PTHRUDIR bit, located in the session registers NC_REG (see [Section 8.3.11](#)), needs to be set to 1b. In case one interface powers off, the Pass-through mode is disabled automatically.

11.3.1 SRAM buffer mapping

In Pass-through mode, the SRAM is mirrored to pages F0h to FFh sector 0 for the NTAG I²C 1k - see [Table 33](#) - or sector 1 for the NTAG I²C 2k - see [Table 34](#) - outside the user memory.

The last page/block of the SRAM buffer (page 16) is used as the terminator page. Once the terminator page/block in the respective interfaces is read/written, the control would be transferred to other interface (RF/I²C) - see [Section 11.3.2](#) and [Section 11.3.3](#) for more details.

Accordingly, the application can align on the Reader & Host side to transfer 16/32/48/64 bytes of data in one Pass-through step by only using the last blocks/page of the SRAM buffer.

When using FAST_READ to read the SRAM buffer from RF, the EndAddr input of the FAST_READ command has to be always set to FFh.

Table 33. Illustration of the SRAM memory addressing via the RF interface in Pass-through mode (PTHRU_ON_OFF set to 1b) for the NTAG I²C 1k

Sector address	Page address		Byte number within a page				Access conditions
	Dec.	Hex.	0	1	2	3	
0	0	00h	Serial number				READ
	1	01h	Serial number			Internal	READ
	2	02h	Internal		Static lock bytes		READ/R&W
	3	03h	Capability Container (CC)				READ&WRITE
	4	04h	User memory				READ&WRITE
					
	15	0Fh					
					
	225	E1h					
	226	E2h	Dynamic lock bytes			00h	R&W/READ
	227	E3h	Invalid access - returns NAK				n.a.
	228	E4h					
	229	E5h					
	230	E6h					
	231	E7h					
	232	E8h	Configuration registers				see 8.3.11
	233	E9h					
	234	EAh	Invalid access - returns NAK				n.a.
	SRAM memory (16 pages)				READ&WRITE
	240	F0h					
...	...						
255	FFh						
1	Invalid access - returns NAK				n.a.
2	Invalid access - returns NAK				n.a.
3	0	00h	Invalid access - returns NAK				n.a.
	Session registers				see 8.3.11
	248	F8h					
	249	F9h					
	Invalid access - returns NAK				n.a.
255	FFh						

Table 34. Illustration of the SRAM memory addressing via the RF interface in Pass-through mode (PTHRU_ON_OFF set to 1b) for the NTAG I²C 2k

Sector address	Page address		Byte number within a page				Access conditions
	Dec.	Hex.	0	1	2	3	
0	0	00h	Serial number				READ
	1	01h	Serial number			Internal	READ
	2	02h	Internal		Static lock bytes		READ/R&W
	3	03h	Capability Container (CC)				READ&WRITE
	4	04h	User memory				READ&WRITE
					
	19	13h					
					
	255	FFh					
1	0	...					
	1	...					
					
					
	223	DFh					
	224	E0h	Dynamic lock bytes		00h		R&W/READ
	225	E1h	Invalid access - returns NAK				n.a.
	226	E2h					
	227	E3h					
	228	E4h					
	229	E5h					
	230	E6h	Configuration registers				see 8.3.11
	231	E7h					
	232	E8h					
	233	E9h	Invalid access - returns NAK				n.a.
	234	EAh					
	SRAM (16 pages)				READ&WRITE
240	F0h						
255	FFh						
2	Invalid access - returns NAK				n.a.
3	0	00h	Invalid access - returns NAK				n.a.
					
	248	F8h	Session registers				see 8.3.11
	249	F9h					
	Invalid access - returns NAK				n.a.
255	FFh						

11.3.2 RF to I²C Data transfer

If the RF interface is enabled (RF_LOCKED = 1b) and data is written to the terminator block/page of the SRAM via the RF interface, at the end of the WRITE command, bit SRAM_I2C_READY is set to 1b and bit RF_LOCKED is set to 0b automatically, and the NTAG I²C is locked to the I²C interface.

To signal to the host that data is ready to be read following mechanisms are in place:

- The host polls/reads bit SRAM_I2C_READY from NS_REG (see [Table 14](#)) to know if data is ready in SRAM
- A trigger on the FD pin indicates to the host that data is ready to be read from SRAM. This feature can be enabled by programming bits 5:2 (FD_OFF, FD_ON) of the NC_REG appropriately (see [Table 13](#))

This is illustrated in the [Figure 24](#).

If the tag is addressed with the correct I²C slave address, the I2C_LOCKED bit is automatically set to 1b (according to the interface arbitration). After a READ from the terminator page of the SRAM, bit SRAM_I2C_READY and bit I2C_LOCKED are automatically reset to 0b, and the tag returns to the arbitration idle mode where, for example, further data from the RF interface can be transferred.

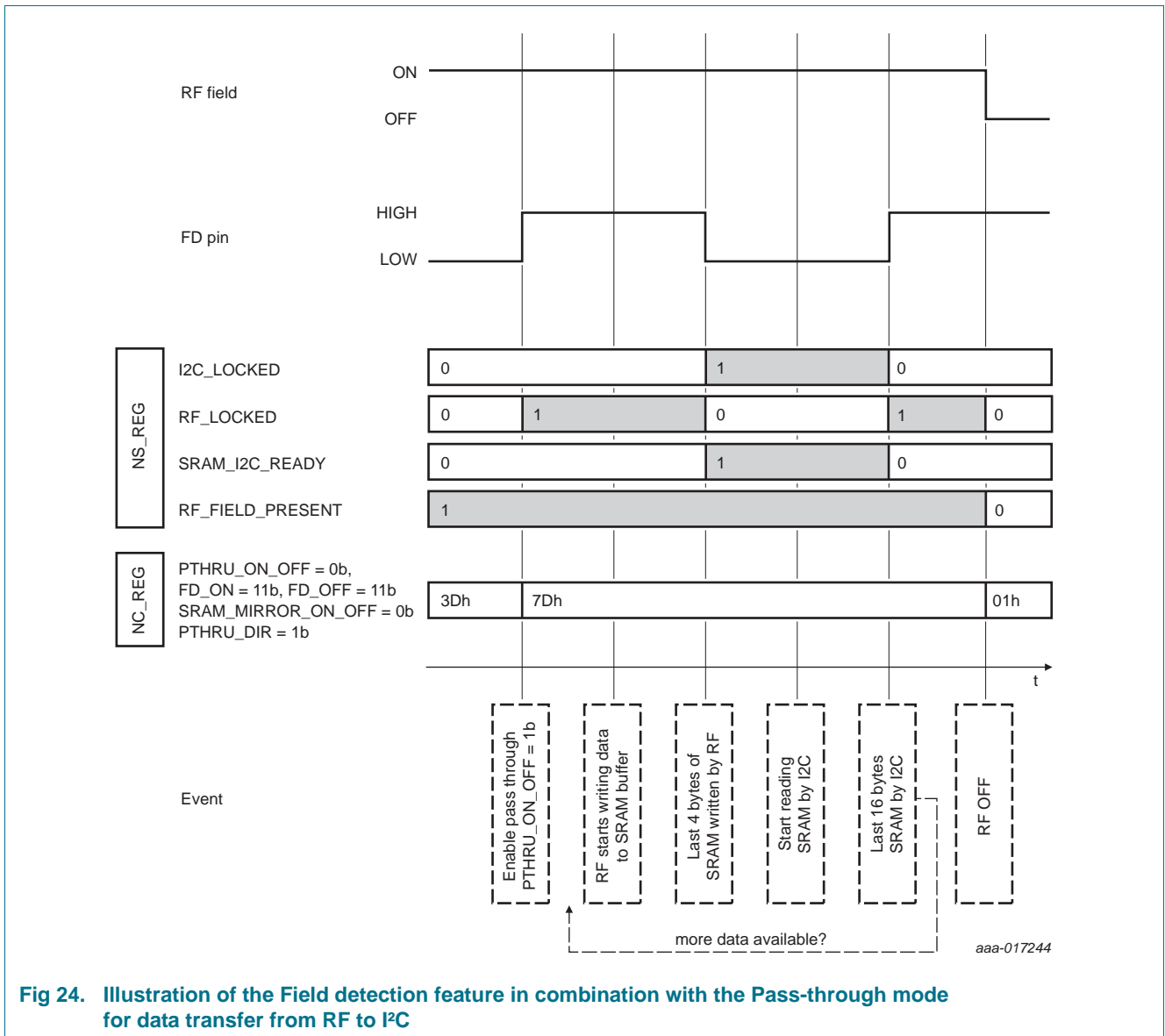

Fig 24. Illustration of the Field detection feature in combination with the Pass-through mode for data transfer from RF to I²C

11.3.3 I²C to RF Data transfer

If the I²C interface is enabled (I2C_LOCKED is 1b) and data is written to the terminator page of the SRAM via the I²C interface, at the end of the WRITE command, bit SRAM_RF_READY is set to 1b and bit I2C_LOCKED is automatically reset to 0b to set the tag in the arbitration idle state.

The RF_LOCKED bit is then automatically set to 1b (according to the interface arbitration). After a READ or FAST_READ command involving the terminator block/page of the SRAM, bit SRAM_RF_READY and bit RF_LOCKED are automatically reset to 0b allowing the I²C interface to further write data into the SRAM buffer.

To signal to the host that further data is ready to be written, the following mechanisms are in place:

- The RF interface polls/reads the bit SRAM_RF_READY from NS_REG (see [Table 14](#)) to know if new data has been written by the I²C interface in the SRAM
- A trigger on the FD pin indicates to the host that data has been read from SRAM by the RF interface. This feature can be enabled by programming bits 5:2 (FD_OFF, FD_ON) of the NC_REG appropriately (see [Table 13](#))

The above mechanism is illustrated in the [Figure 25](#).

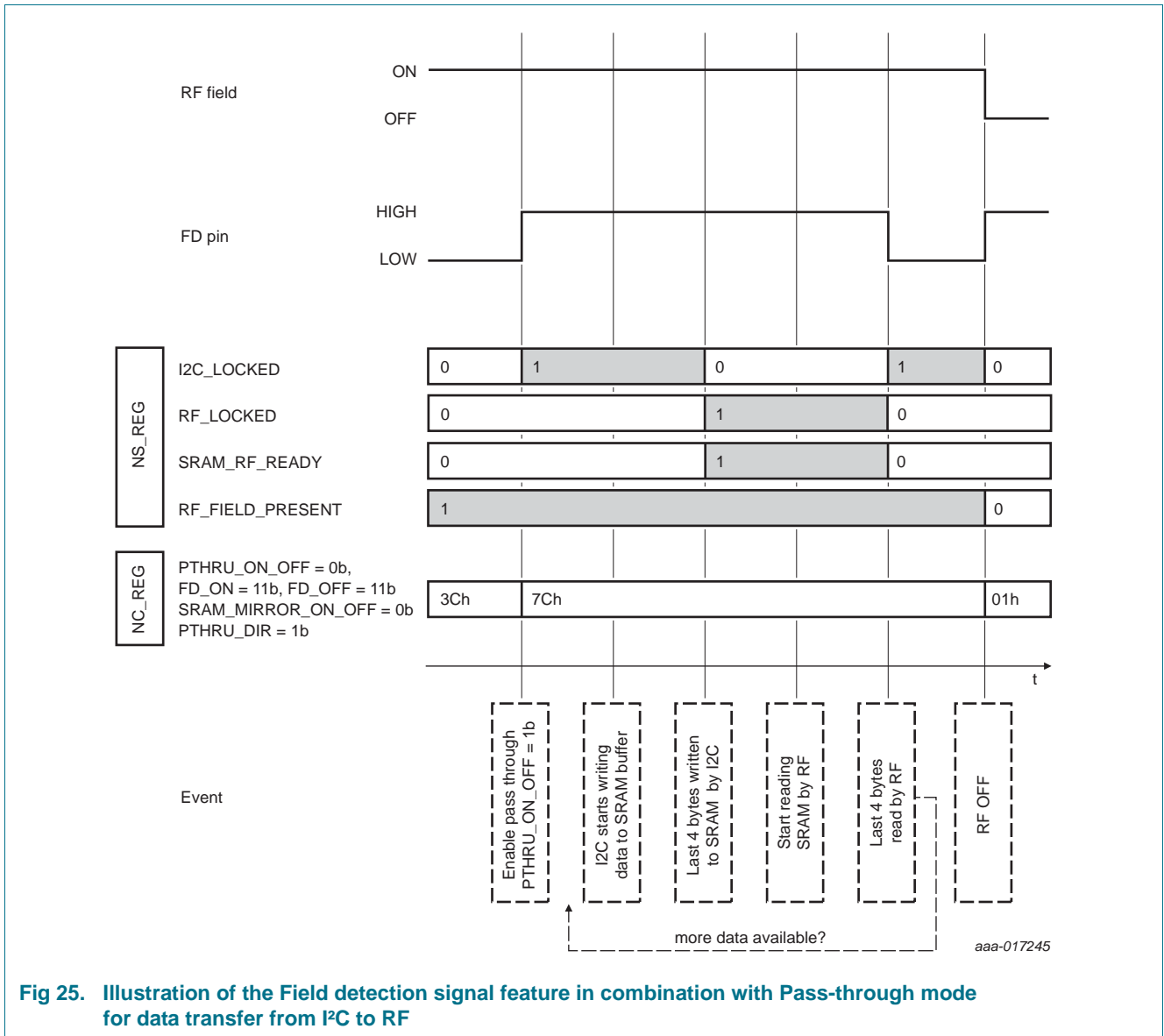

Fig 25. Illustration of the Field detection signal feature in combination with Pass-through mode for data transfer from I²C to RF

12. Limiting values

Exceeding the limits of one or more values in reference may cause permanent damage to the device. Exposure to limiting values for extended periods may affect device reliability.

Table 35. Limiting values

In accordance with the Absolute Maximum Rating System (IEC 60134).^{[1][2][3]}

Symbol	Parameter	Conditions	Min	Max	Unit
I _I	input current LA - LB		-	40	mA
T _{stg}	storage temperature		-55	+125	°C
V _{ESD}	electrostatic discharge voltage	[3]	2	-	kV
V _{FD}	Voltage on the FD pin		-	3.6	V
V _{SDA}	Voltage on the SDA line		-	3.6	V
V _{SCL}	Voltage on the SCL line		-	3.6	V

[1] Stresses above one or more of the limiting values may cause permanent damage to the device.

[2] Exposure to limiting values for extended periods may affect device reliability.

[3] ANSI/ESDA/JEDEC JS-001; Human body model: C = 100 pF, R = 1.5 kΩ.

13. Characteristics

13.1 Electrical characteristics

Table 36. Characteristics

Symbol	Parameter	Conditions	Min	Typ	Max	Unit
C _i	input capacitance	LA - LB	44	50	56	pF
f _i	input frequency		-	13.56	-	MHz
T _{oper}	operating temperature		-40	-	+95	°C
Energy harvesting characteristics						
V _{out}	voltage generated at the V _{out} pin		-	-	3.2	V
I²C interface characteristics						
V _{CC}	supply voltage	NTAG I ² C supplied via V _{CC} only	1.7 [1]		3.6	V
I _{DD}	supply current		-	155	-	μA
EEPROM characteristics						
t _{ret}	retention time	full operating temperature range	20	-	-	year
N _{endu(W)}	write endurance	full operating temperature range	500000	-	-	cycle

[1] A minimum supply voltage of 1.8 V is required, when RF field is present.

14. Package outline

XQFN8: plastic, extremely thin quad flat package; no leads;
8 terminals; body 1.6 x 1.6 x 0.5 mm

SOT902-3

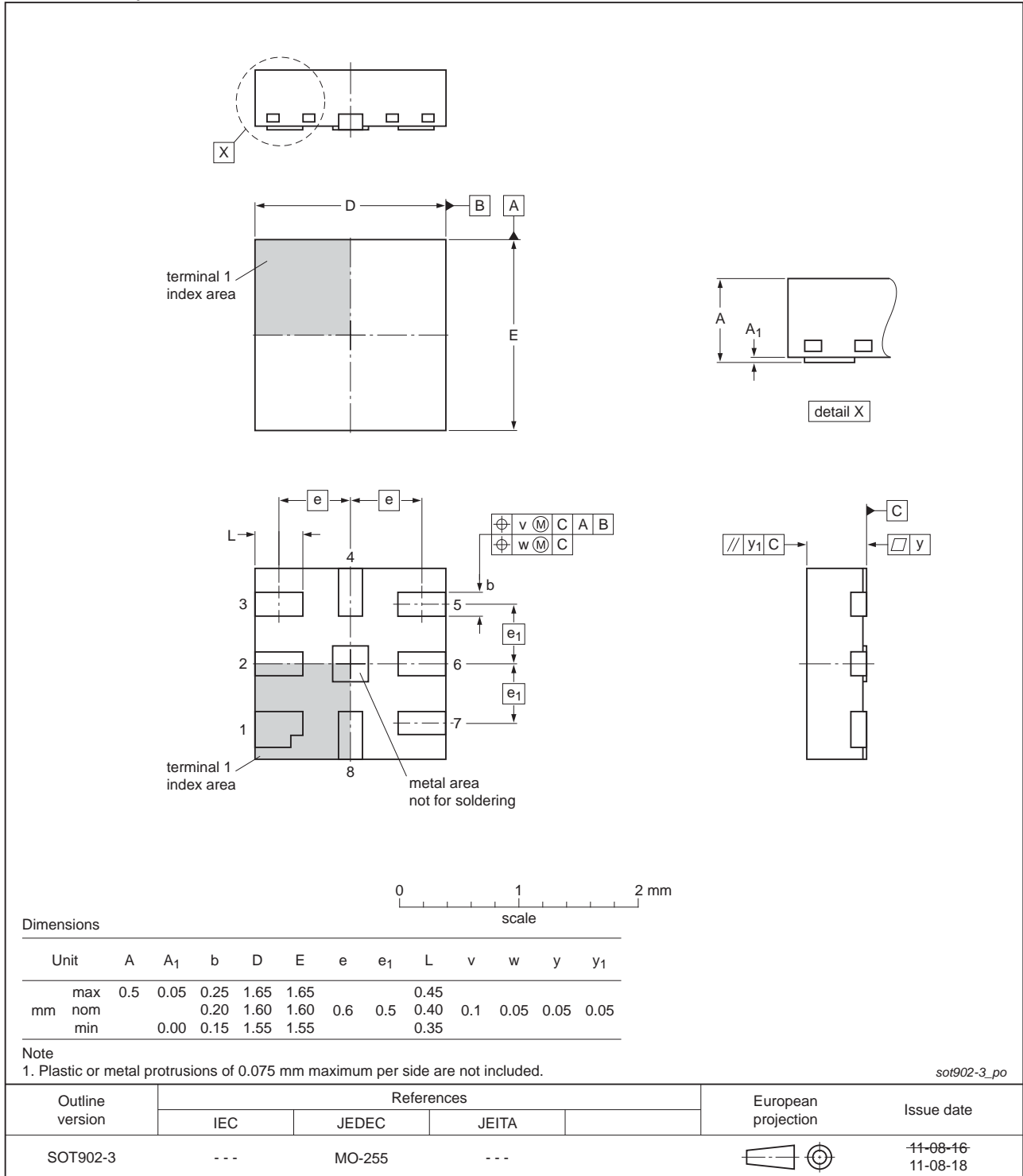

Fig 26. Package outline SOT902-3 (XQFN8)

TSSOP8: plastic thin shrink small outline package; 8 leads; body width 3 mm

SOT505-1

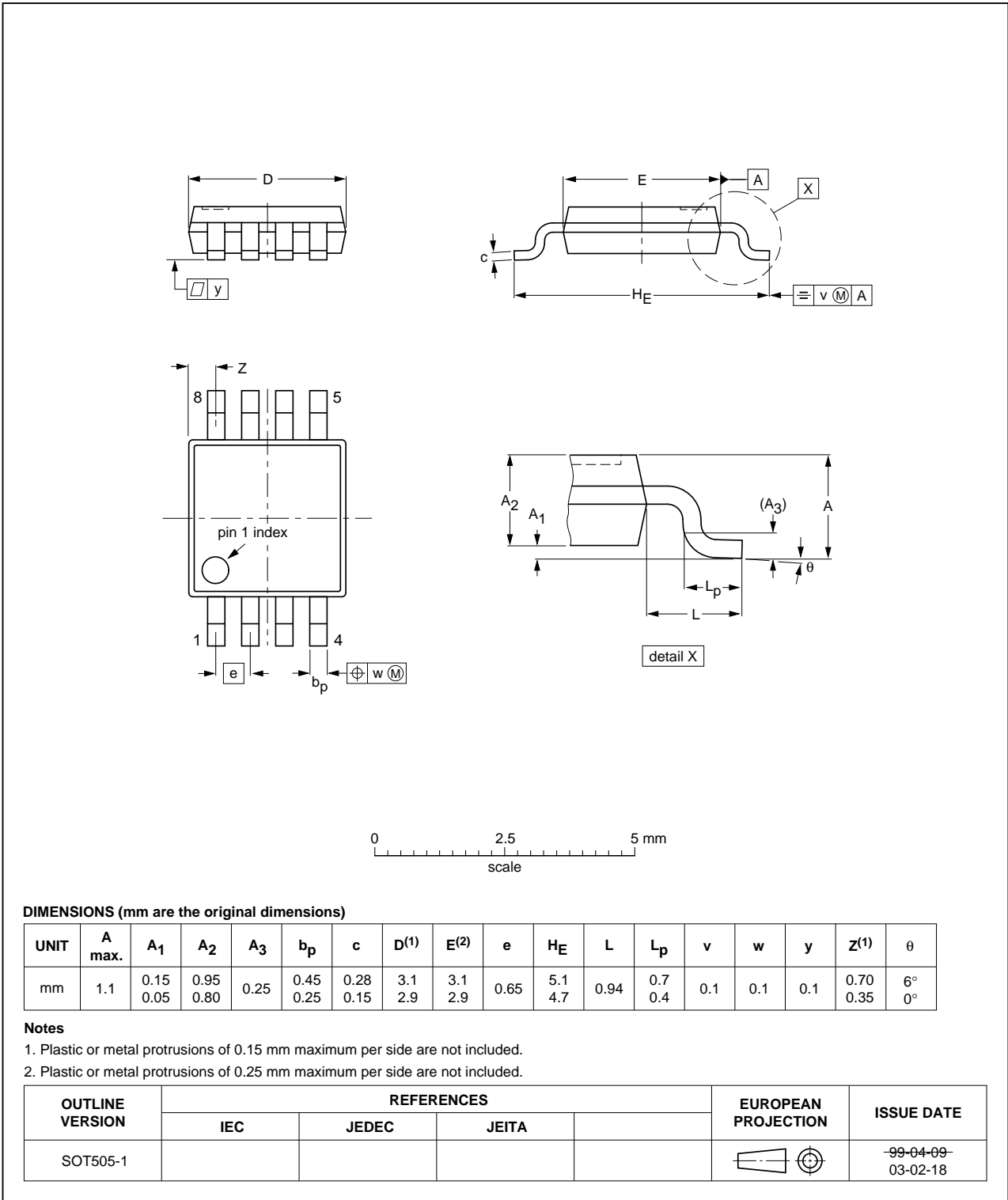

Fig 27. Package outline SOT505-1 (TSSOP8)

Table 37. Pin description

Pin no.	Symbol	Description
1	LA	Antenna connection LA
2	VSS	GND
3	SCL	Serial Clock I ² C
4	FD	Field detection
5	SDA	Serial data I ² C
6	VCC	VCC in connection (external power supply)
7	V _{out}	Voltage out (energy harvesting)
8	LB	Antenna connection LB

15. Abbreviations

Table 38. Abbreviations

Acronym	Description
POR	Power On Reset

16. References

- [1] NFC Forum - Type 2 Tag Operation V1.2
Technical Specification
- [2] ISO/IEC 14443 - Identification cards - Contactless integrated circuit cards -
Proximity cards
International Standard
- [3] I2C-bus specification and user manual
NXP standard UM10204
- [4] NFC Forum - Activity V1.1
Technical Specification

17. Revision history

Table 39. Revision history

Document ID	Release date	Data sheet status	Change notice	Supersedes
NT3H1101_1201 v. 3.3	20150715	Product data sheet	-	NT3H1101_1201 v. 3.2
Modifications:	<ul style="list-style-type: none"> • Table 1 “Ordering information”: updated • Capacitor value for energy harvesting corrected • Table 35 “Limiting values”: updated • Table 36 “Characteristics”: updated 			
NT3H1101_1201 v. 3.2	20150325	Product data sheet	-	NT3H1101_1201 v. 3.1
Modifications:	<ul style="list-style-type: none"> • Table 1 “Ordering information”: updated • Table 2 “Marking codes”: updated • Section 7.1: Figure 4 added • Section 14 “Package outline”: Figure 27 added • General update 			
NT3H1101_1201 v. 3.1	20141009	Product data sheet	-	NT3H1101_1201 v. 3.0
Modifications:	<ul style="list-style-type: none"> • Section 8.6 “Energy harvesting”: updated • Section 10.5 “GET_VERSION”: updated • Figure 24 and Figure 25: updated • Section 12 “Limiting values” and Section 13 “Characteristics”: remark removed 			
NT3H1101_1201 v. 3.0	20140806	Product data sheet	-	NT3H1101_1201 v. 2.3
Modifications:	<ul style="list-style-type: none"> • Section 8.6 “Energy harvesting” updated • Section 16 “References”: updated • Data sheet status changed to “Product data sheet” 			
NT3H1101_1201 v. 2.3	20140708	Objective data sheet	-	NT3H1201_1101 v. 2.2
Modifications:	<ul style="list-style-type: none"> • Figures updated • General update 			
NT3H1101_1201 v. 2.2	20140306	Objective data sheet	-	NT3H1201_1101 v. 2.1
Modifications:	<ul style="list-style-type: none"> • General updates 			
NT3H1101_1201 v. 2.1	20131218	Objective data sheet	-	NT3H1201_1101 v. 2.0
Modifications:	<ul style="list-style-type: none"> • Section 4 “Ordering information”: type number corrected 			
NT3H1101_1201 v. 2.0	20131212	Objective data sheet		NT3H1201 v. 1.4
Modifications:	<ul style="list-style-type: none"> • Additional description for the Field detection functionality for Pass-through mode • General update 			
NT3H1201 v. 1.4	20130802	Objective data sheet	-	NT3H1201 v. 1.3
Modifications:	<ul style="list-style-type: none"> • Update for 1k memory version and RF commands 			
NT3H1201 v. 1.3	20130613	Objective data sheet	-	
Modifications:	<ul style="list-style-type: none"> • Pinning package update 			
NT3H1201 v. 1.0	20130425	Objective data sheet	-	-

18. Legal information

18.1 Data sheet status

Document status ^{[1][2]}	Product status ^[3]	Definition
Objective [short] data sheet	Development	This document contains data from the objective specification for product development.
Preliminary [short] data sheet	Qualification	This document contains data from the preliminary specification.
Product [short] data sheet	Production	This document contains the product specification.

[1] Please consult the most recently issued document before initiating or completing a design.

[2] The term 'short data sheet' is explained in section "Definitions".

[3] The product status of device(s) described in this document may have changed since this document was published and may differ in case of multiple devices. The latest product status information is available on the Internet at URL <http://www.nxp.com>.

18.2 Definitions

Draft — The document is a draft version only. The content is still under internal review and subject to formal approval, which may result in modifications or additions. NXP Semiconductors does not give any representations or warranties as to the accuracy or completeness of information included herein and shall have no liability for the consequences of use of such information.

Short data sheet — A short data sheet is an extract from a full data sheet with the same product type number(s) and title. A short data sheet is intended for quick reference only and should not be relied upon to contain detailed and full information. For detailed and full information see the relevant full data sheet, which is available on request via the local NXP Semiconductors sales office. In case of any inconsistency or conflict with the short data sheet, the full data sheet shall prevail.

Product specification — The information and data provided in a Product data sheet shall define the specification of the product as agreed between NXP Semiconductors and its customer, unless NXP Semiconductors and customer have explicitly agreed otherwise in writing. In no event however, shall an agreement be valid in which the NXP Semiconductors product is deemed to offer functions and qualities beyond those described in the Product data sheet.

18.3 Disclaimers

Limited warranty and liability — Information in this document is believed to be accurate and reliable. However, NXP Semiconductors does not give any representations or warranties, expressed or implied, as to the accuracy or completeness of such information and shall have no liability for the consequences of use of such information. NXP Semiconductors takes no responsibility for the content in this document if provided by an information source outside of NXP Semiconductors.

In no event shall NXP Semiconductors be liable for any indirect, incidental, punitive, special or consequential damages (including - without limitation - lost profits, lost savings, business interruption, costs related to the removal or replacement of any products or rework charges) whether or not such damages are based on tort (including negligence), warranty, breach of contract or any other legal theory.

Notwithstanding any damages that customer might incur for any reason whatsoever, NXP Semiconductors' aggregate and cumulative liability towards customer for the products described herein shall be limited in accordance with the *Terms and conditions of commercial sale* of NXP Semiconductors.

Right to make changes — NXP Semiconductors reserves the right to make changes to information published in this document, including without limitation specifications and product descriptions, at any time and without notice. This document supersedes and replaces all information supplied prior to the publication hereof.

Suitability for use — NXP Semiconductors products are not designed, authorized or warranted to be suitable for use in life support, life-critical or safety-critical systems or equipment, nor in applications where failure or malfunction of an NXP Semiconductors product can reasonably be expected to result in personal injury, death or severe property or environmental damage. NXP Semiconductors and its suppliers accept no liability for inclusion and/or use of NXP Semiconductors products in such equipment or applications and therefore such inclusion and/or use is at the customer's own risk.

Applications — Applications that are described herein for any of these products are for illustrative purposes only. NXP Semiconductors makes no representation or warranty that such applications will be suitable for the specified use without further testing or modification.

Customers are responsible for the design and operation of their applications and products using NXP Semiconductors products, and NXP Semiconductors accepts no liability for any assistance with applications or customer product design. It is customer's sole responsibility to determine whether the NXP Semiconductors product is suitable and fit for the customer's applications and products planned, as well as for the planned application and use of customer's third party customer(s). Customers should provide appropriate design and operating safeguards to minimize the risks associated with their applications and products.

NXP Semiconductors does not accept any liability related to any default, damage, costs or problem which is based on any weakness or default in the customer's applications or products, or the application or use by customer's third party customer(s). Customer is responsible for doing all necessary testing for the customer's applications and products using NXP Semiconductors products in order to avoid a default of the applications and the products or of the application or use by customer's third party customer(s). NXP does not accept any liability in this respect.

Limiting values — Stress above one or more limiting values (as defined in the Absolute Maximum Ratings System of IEC 60134) will cause permanent damage to the device. Limiting values are stress ratings only and (proper) operation of the device at these or any other conditions above those given in the Recommended operating conditions section (if present) or the Characteristics sections of this document is not warranted. Constant or repeated exposure to limiting values will permanently and irreversibly affect the quality and reliability of the device.

Terms and conditions of commercial sale — NXP Semiconductors products are sold subject to the general terms and conditions of commercial sale, as published at <http://www.nxp.com/profile/terms>, unless otherwise agreed in a valid written individual agreement. In case an individual agreement is concluded only the terms and conditions of the respective agreement shall apply. NXP Semiconductors hereby expressly objects to applying the customer's general terms and conditions with regard to the purchase of NXP Semiconductors products by customer.

No offer to sell or license — Nothing in this document may be interpreted or construed as an offer to sell products that is open for acceptance or the grant, conveyance or implication of any license under any copyrights, patents or other industrial or intellectual property rights.

Export control — This document as well as the item(s) described herein may be subject to export control regulations. Export might require a prior authorization from competent authorities.

Quick reference data — The Quick reference data is an extract of the product data given in the Limiting values and Characteristics sections of this document, and as such is not complete, exhaustive or legally binding.

Non-automotive qualified products — Unless this data sheet expressly states that this specific NXP Semiconductors product is automotive qualified, the product is not suitable for automotive use. It is neither qualified nor tested in accordance with automotive testing or application requirements. NXP Semiconductors accepts no liability for inclusion and/or use of non-automotive qualified products in automotive equipment or applications.

In the event that customer uses the product for design-in and use in automotive applications to automotive specifications and standards, customer (a) shall use the product without NXP Semiconductors' warranty of the product for such automotive applications, use and specifications, and (b) whenever customer uses the product for automotive applications beyond NXP Semiconductors' specifications such use shall be solely at customer's own risk, and (c) customer fully indemnifies NXP Semiconductors for any liability, damages or failed product claims resulting from customer design and use of the product for automotive applications beyond NXP Semiconductors' standard warranty and NXP Semiconductors' product specifications.

Translations — A non-English (translated) version of a document is for reference only. The English version shall prevail in case of any discrepancy between the translated and English versions.

18.4 Licenses

Purchase of NXP ICs with NFC technology

Purchase of an NXP Semiconductors IC that complies with one of the Near Field Communication (NFC) standards ISO/IEC 18092 and ISO/IEC 21481 does not convey an implied license under any patent right infringed by implementation of any of those standards.

18.5 Trademarks

Notice: All referenced brands, product names, service names and trademarks are the property of their respective owners.

I²C-bus — logo is a trademark of NXP Semiconductors N.V.

19. Contact information

For more information, please visit: <http://www.nxp.com>

For sales office addresses, please send an email to: salesaddresses@nxp.com

20. Contents

1	General description	1	9.3	Soft reset feature	34
2	Features and benefits	2	9.4	Acknowledge bit (ACK)	34
2.1	Key features	2	9.5	Data input	34
2.2	RF interface	2	9.6	Addressing	34
2.3	Memory	2	9.7	READ and WRITE Operation	35
2.4	I ² C interface	3	9.8	WRITE and READ register operation	37
2.5	Security	3	10	RF Command	39
2.6	Key benefits	3	10.1	NTAG I ² C command overview	39
3	Applications	3	10.2	Timing	39
4	Ordering information	4	10.3	NTAG ACK and NAK	40
5	Marking	4	10.4	ATQA and SAK responses	40
6	Block diagram	5	10.5	GET_VERSION	41
7	Pinning information	6	10.6	READ	42
7.1	Pinning	6	10.7	FAST_READ	43
7.1.1	XQFN8	6	10.8	WRITE	45
7.1.2	TSSOP8	6	10.9	SECTOR SELECT	46
7.2	Pin description	7	11	Communication and arbitration between RF and I²C interface	48
8	Functional description	8	11.1	Non-Pass-through mode	48
8.1	Block description	8	11.1.1	I ² C interface access	48
8.2	RF interface	8	11.1.2	RF interface access	48
8.2.1	Data integrity	9	11.2	SRAM buffer mapping with Memory Mirror enabled	49
8.2.2	RF communication principle	10	11.3	Pass-through mode	52
8.2.2.1	IDLE state	10	11.3.1	SRAM buffer mapping	52
8.2.2.2	READY 1 state	10	11.3.2	RF to I ² C Data transfer	55
8.2.2.3	READY 2 state	11	11.3.3	I ² C to RF Data transfer	56
8.2.2.4	ACTIVE state	11	12	Limiting values	58
8.2.2.5	HALT state	11	13	Characteristics	58
8.3	Memory organization	11	13.1	Electrical characteristics	58
8.3.1	Memory map from RF interface	11	14	Package outline	59
8.3.2	Memory map from I ² C interface	13	15	Abbreviations	61
8.3.3	EEPROM	16	16	References	61
8.3.4	SRAM	16	17	Revision history	62
8.3.5	UID/serial number	16	18	Legal information	63
8.3.6	Static lock bytes	17	18.1	Data sheet status	63
8.3.7	Dynamic Lock Bytes	18	18.2	Definitions	63
8.3.8	Capability Container (CC bytes)	20	18.3	Disclaimers	63
8.3.9	User Memory pages	20	18.4	Licenses	64
8.3.10	Memory content at delivery	21	18.5	Trademarks	64
8.3.11	NTAG I ² C configuration and session registers	21	19	Contact information	64
8.4	Configurable Field Detection Pin	28	20	Contents	65
8.5	Watchdog timer	32			
8.6	Energy harvesting	32			
9	I²C commands	33			
9.1	Start condition	33			
9.2	Stop condition	33			

Please be aware that important notices concerning this document and the product(s) described herein, have been included in section 'Legal information'.

© NXP Semiconductors N.V. 2015.

All rights reserved.

For more information, please visit: <http://www.nxp.com>

For sales office addresses, please send an email to: salesaddresses@nxp.com

Date of release: 15 July 2015
265433

X-ON Electronics

Largest Supplier of Electrical and Electronic Components

Click to view similar products for [NFC/RFID Tags & Transponders](#) category:

Click to view products by [NXP](#) manufacturer:

Other Similar products are found below :

[PCF7941ATSM2AB120](#), [NT2H0301F0DTL,125](#) [PNEV512B,699](#) [V680-D1KP54T](#) [V680S-A40 50M](#) [PN7120A0EV/C10801Y](#)

[TRPGR30ATGA](#) [SPS1M003B](#) [SPS1M003A](#) [SPS1M002B](#) [SPS1M002A](#) [V680S-A40 10M](#) [V680-D1KP66T](#) [ATA5577M2330C-DBQ](#)

[SL2S5302FTBX](#) [LXMSJZNCMD-217](#) [60208](#) [60170](#) [P5DF081X0/T1AD2060](#) [MF1S5030XDA8/V1J](#) [MF1S7030XDA4/V1J](#)

[HT1MOA4S30/E/3J](#) [HT2MOA4S20/E/3/RJ](#) [MFRC52302HN1,157](#) [TRPGR30ATGB](#) [NRF51822-QFAA-R](#) [20926410601](#) [CLRC66303HNE](#)

[ART915X1620TX16-IC](#) [ART915X2117225TX21-IC](#) [28448](#) [ART923X1015YZ10-IC](#) [ART868X130903TX13](#) [ART868X25275YZ25](#)

[ART915X050503OP-IC](#) [ART915X100202TO-IC](#) [ART915X100503JA-IC](#) [ART915X130930TX13-IC](#) [ART915X250903AM-IC](#)

[ART915X2509EP60-IC](#) [ART915X252503MA-IC](#) [ART915X25275YZ25](#) [ART915X25275YZ25-IC](#) [ART923X1015YZ10](#) [AS3932-BTST](#)

[AS3933-BTST](#) [20926410802](#) [LXMSJZNCMF-198](#) [MIKROE-779](#) [13356-0571](#)