

NTBatteryManagementSystem: Safety reference design in compliance to ISO 26262 ASIL C

Description

NTBMS is a Battery Management System for manufacturer of automotive Battery Systems, used as Starter Battery or Auxiliary Battery with Li-Ion cells.

The NTBMS platform is designed for systems with high demand on reliability and safety in compliance with ISO 26262 ASIL C.

NTBMS is a generic safety reference design for BMS developed in cooperation with NXP. The Battery Management System of Li-Ion battery includes cell monitoring, current sensing, passive cell balancing, battery breaker control, computation unit for Battery parameter extraction (such as State of Charge, State of Health) and communication to other ECU through CAN.

Battery management systems (BMS) are responsible to steer and control high-voltage batteries of Electric and Hybrid Electric Vehicles. This control unit is essential since several battery cells are unified to a cluster to enhance battery capacity. It is a charge regulator which should guarantee a stringent power supply of the engine.

BMS are essential to monitor state of charge, load distribution, temperature of each battery cell as well as of the whole battery package and development of the charging capacity.

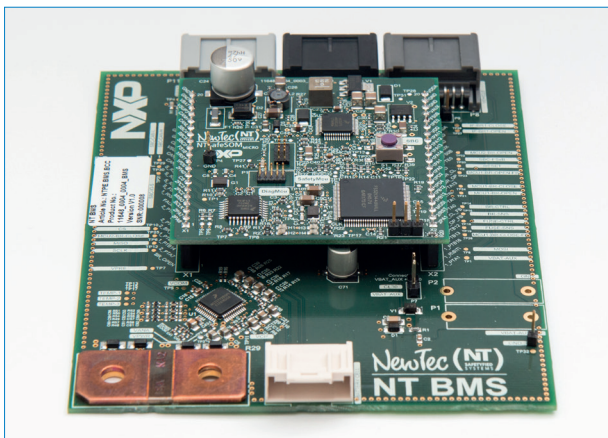

Figure 1: NTBMS Baseboard & NT SafeSOMmicro

Typical Applications

- _ Automotive BMS for Starter Battery with Li-Ion battery
- _ Automotive BMS for Auxiliary Battery
- _ Smart Grids
- _ Other Battery Management opportunities (medical, e-Bike, light transportation, industrial)

Customer Benefits

- _ Accelerate time to market
- _ Reduction in costs for development and certification
- _ Safety Development Platform for BMS
- _ Reference Design in compliance to ISO 26262 ASIL C

Key Features

- _ Integrated system diagnostic functions up to ASIL C
- _ Overcurrent protection
- _ Overcharge protection
- _ Over-temperature protection
- _ Over-voltage protection
- _ Under-voltage protection (short circuit)
- _ Protection against unintended relay close
- _ Protection against unintended relay open
- _ Crash detection input

Technical Data

Power Supply

The device is designed for operation with 12V to 18V DC power Supply. Operation with other supply voltages is not permitted. The supply voltage is connected via the connection cable provided for this purpose.

Environmental Conditions

Temperature

The device is designed for storage and operations at the following temperature ranges:

- _ Storage temperature: -15°C to +70°C
- _ Operating temperature: 0°C to +40°C

Battery Characteristics

Electrical current carrying capability for shunt resistor

- _ 250 A permanent;
- _ 600 A for 40 s;
- _ 1400 A for 1 s

Battery Management System current

- _ operating current < 25 mA@RT

Other Characteristics

- _ Intrusive diagnostics (performed by MCU)
- _ Memory storage (RAM & flash)
- _ Power management (low power and normal mode)
- _ LIN for starter batteries
- _ CAN for the auxiliary batteries.

System Overview

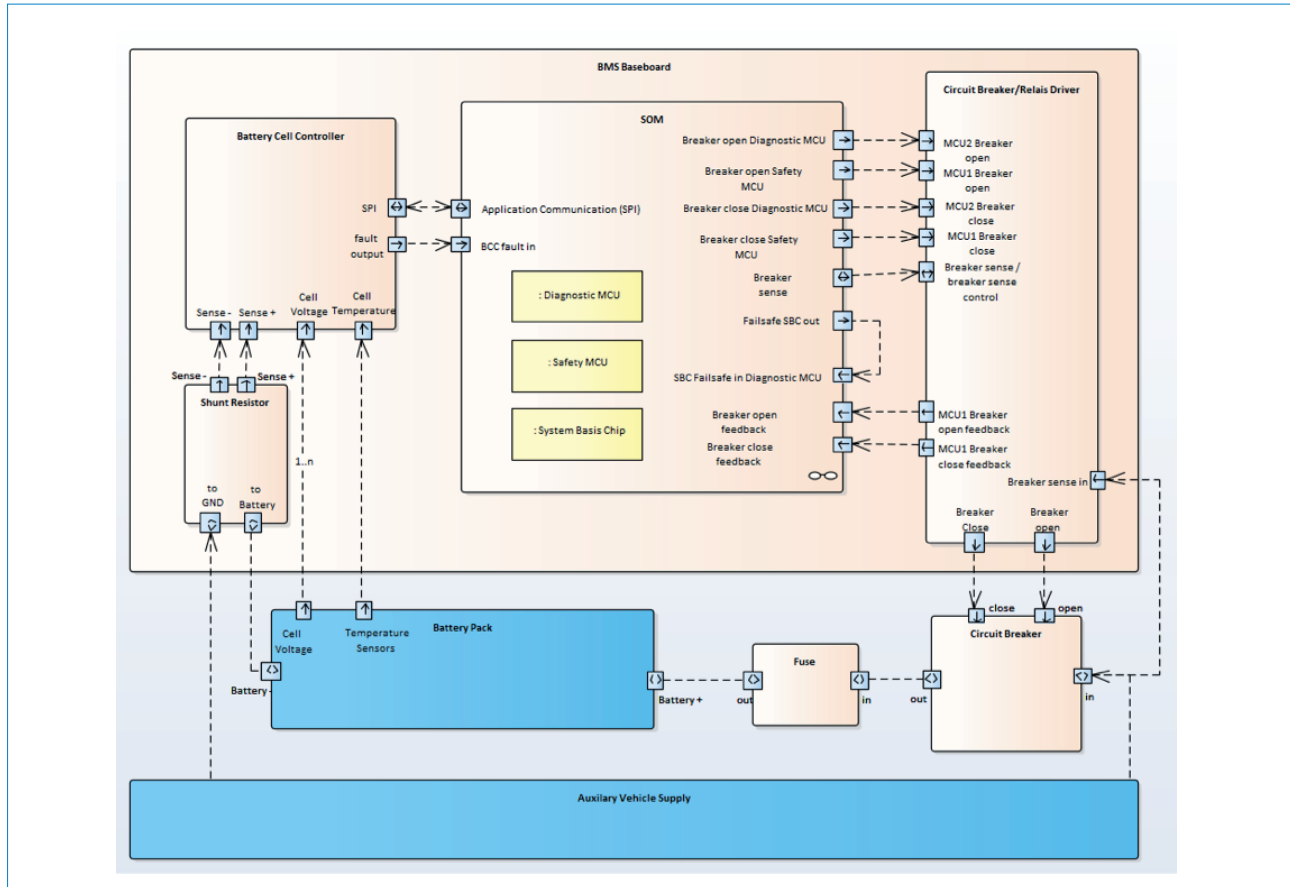

Figure 2: Block Diagram NT Battery Management System

Operations

Access to the Device

During operations, the user must prevent access to or contact with the device for children, pets, plants, and insects.

Controls and Display Elements SafeSOMmicro

S1: Reset Button

H1: Diagnostic MCU, User defined LED

H2: Diagnostic MCU, User defined LED

H3: Safety MCU Status LED: LED on = Initialization successful

H4: Safety MCU Status LED: LED Blinking = MCU communication OK; LED ON = Error

H5: VDD present

Controls and Display Elements BMS Baseboards

H1: BCC Fault output LED

Jumper Settings BMS Base Board:

P3: Soldering Jumper for Breaker sense control selection:

Short Pin 1+2: BCC (default), Short Pin 2+3: MCU1

P4: Close Jumper to enable CAN Termination

P7: Close Jumper to supply VBAT_AUX from CL30

Connector Description SafeSOMmicro

P1: JTAG Interface Diagnostic MCU

2x5 Pin Header RM 1,27mm

Pin Number	Description	Pin Number	Description
1	3V3	2	TMS
3	GND	4	TCLK
5	GND	6	TDO
7	NC	8	TDI
9	NC	10	/MCU Reset

P2: JTAG Interface Safety MCU

2x5 Pin Header RM 1,27mm

Pin Number	Description	Pin Number	Description
1	5V	2	TMS
3	GND	4	TCLK
5	GND	6	TDO
7	NC	8	TDI
9	NC	10	/MCU Reset

P3: TTL UART Connector, 5V
3 Pin Header RM2,54mm

Pin Number	Description
1	GND
2	MCU TX
3	MCU RX

P4: GND
Single Pin

X1: Baseboard Connector 1

Pin Number	Description	Pin Number	Description
1	MCU2 PTA6	11	SBC FS1B
2	MCU2 PTA7	12	SBC IO0
3	SPI CLK	13	SBC IO5
4	SPI MISO	14	SBC IO4
5	MCU2 PTC2	15	CAN Low
6	MCU2 PTC3	16	CAN High
7	SPI CS	17	VSUP3: Filtered VBAT output
8	MCU2 PTA0	18	VBAT: 12V Power supply input
9	MCU1 PTDO	19	GND
10	MCU1 /RST	20	GND

X2 Baseboard Connector 2

Pin Number	Description	Pin Number	Description
1		11	MCU1 PTA13
2		12	MCU1 PTA12
3		13	MCU1 PTA11
4		14	VDD: 5V
5		15	SBC PTE0
6		16	SBC FS0B
7		17	VAUX: 5V
8		18	GND
9		19	GND
10		20	VDDA: 5V

Connector Description BMS BaseBoard

P1: VBat+ Measurement Connector

4mm Banana Jack, not fitted by default, Part No: Hirschmann 973 582-101

P2: VBat- Measurement Connector

4mm Banana Jack, not fitted by default, Part No: Hirschmann 973 582-100

P5: GND

P6: Breaker Connector

Molex 34793-0080

Pin Number	Description	Pin Number	Description
1	12V	5	NC
2	Breaker Close	6	NC
3	12V	7	Fuse Sense Input (optional)
4	Breaker Open	8	Breaker Sense Input

P8: Vehicle Connector

Molex 34793-0082

Pin Number	Description	Pin Number	Description
1	CL30 Input	5	Feature Connector
2	CAN High	6	Feature Connector
3	CAN Low	7	Feature Connector
4	Crach detection input	8	GND

P9: Feature Connector

3 Pin Header RM2,54mm, reserved for future use.

P10: Battery Cell Connector

Molex 501876-1640

Pin Number	Description	Pin Number	Description
1	GND	9	Cell 1
2	Temp Sensor 1	10	CTRef
3	GND	11	Cell 3
4	Temp Sensor 2	12	Cell 2
5	GND	13	Cell 5
6	Temp Sensor 3	14	Cell 4
7	GND	15	VBAT_AUX
8	GND	16	Cell 6

P11: Aux Connector (Semiconductor Relais)

Molex 34793-0081

Packages & Services

	Reference design	Board Package	Software Package	Safety Package	Certification Package
Schematic	✓	✓	✓	✓	✓
Layout w/ Gerber Files	✓	✓	✓	✓	✓
Application Software with Driver (Non Safe) Layout w/ Gerber Files	✓	✓	✓	✓	✓
Introduction Guide for ASIL C	✓	✓	✓	✓	✓
Templates and FMEDA Results	✓	✓	✓	✓	✓
Evaluation Board		✓	✓	✓	✓
HowTo Guide for ASIL C		✓	✓	✓	✓
Safety Software for BMS (Object Code)		✓		✓	✓
Safety Software License for BMS (Source Code)			✓		✓
Complete Safety Documentation for certification				✓	✓
Certification					✓
Support			✓	✓	✓

Figure 3:
Available Solution Option for
NTBatteryManagementSystem

X-ON Electronics

Largest Supplier of Electrical and Electronic Components

Click to view similar products for [Power Management IC Development Tools](#) category:

Click to view products by [NXP](#) manufacturer:

Other Similar products are found below :

[EVAL-ADM1168LQEBZ](#) [EVB-EP5348UI](#) [MIC23451-AAAYFL EV](#) [MIC5281YMME EV](#) [DA9063-EVAL](#) [ADP122-3.3-EVALZ](#) [ADP130-0.8-EVALZ](#) [ADP130-1.2-EVALZ](#) [ADP130-1.5-EVALZ](#) [ADP130-1.8-EVALZ](#) [ADP1712-3.3-EVALZ](#) [ADP1714-3.3-EVALZ](#) [ADP1715-3.3-EVALZ](#) [ADP1716-2.5-EVALZ](#) [ADP1740-1.5-EVALZ](#) [ADP1752-1.5-EVALZ](#) [ADP1828LC-EVALZ](#) [ADP1870-0.3-EVALZ](#) [ADP1871-0.6-EVALZ](#) [ADP1873-0.6-EVALZ](#) [ADP1874-0.3-EVALZ](#) [ADP1882-1.0-EVALZ](#) [ADP199CB-EVALZ](#) [ADP2102-1.25-EVALZ](#) [ADP2102-1.875EVALZ](#) [ADP2102-1.8-EVALZ](#) [ADP2102-2-EVALZ](#) [ADP2102-3-EVALZ](#) [ADP2102-4-EVALZ](#) [ADP2106-1.8-EVALZ](#) [ADP2147CB-110EVALZ](#) [AS3606-DB](#) [BQ24010EVM](#) [BQ24075TEVM](#) [BQ24155EVM](#) [BQ24157EVM-697](#) [BQ24160EVM-742](#) [BQ24296MEVM-655](#) [BQ25010EVM](#) [BQ3055EVM](#) [NCV891330PD50GEVB](#) [ISLUSBI2CKIT1Z](#) [LM2744EVAL](#) [LM2854EVAL](#) [LM3658SD-AEV/NOPB](#) [LM3658SDEV/NOPB](#) [LM3691TL-1.8EV/NOPB](#) [LM4510SDEV/NOPB](#) [LM5033SD-EVAL](#) [LP38512TS-1.8EV](#)