

# NVT2001; NVT2002

## Bidirectional voltage level translator for open-drain and push-pull applications

Rev. 4.1 — 6 December 2019

Product data sheet

### 1. General description

---

The NVT2001/02 are bidirectional voltage level translators operational from 1.0 V to 3.6 V ( $V_{\text{ref(A)}}$ ) and 1.8 V to 5.5 V ( $V_{\text{ref(B)}}$ ), which allow bidirectional voltage translations between 1.0 V and 5 V without the need for a direction pin in open-drain or push-pull applications. Bit widths ranging from 1-bit or 2-bit are offered for level translation application with transmission speeds < 33 MHz for an open-drain system with a 50 pF capacitance and a pull-up of 197  $\Omega$ .

When the An or Bn port is LOW, the clamp is in the ON-state and a low resistance connection exists between the An and Bn ports. The low ON-state resistance ( $R_{\text{on}}$ ) of the switch allows connections to be made with minimal propagation delay. Assuming the higher voltage is on the Bn port when the Bn port is HIGH, the voltage on the An port is limited to the voltage set by VREFA. When the An port is HIGH, the Bn port is pulled to the drain pull-up supply voltage ( $V_{\text{pu(D)}}$ ) by the pull-up resistors. This functionality allows a seamless translation between higher and lower voltages selected by the user without the need for directional control.

When EN is HIGH, the translator switch is on, and the An I/O are connected to the Bn I/O, respectively, allowing bidirectional data flow between ports. When EN is LOW, the translator switch is off, and a high-impedance state exists between ports. The EN input circuit is designed to be supplied by  $V_{\text{ref(B)}}$ . To ensure the high-impedance state during power-up or power-down, EN must be LOW.

All channels have the same electrical characteristics and there is minimal deviation from one output to another in voltage or propagation delay. This is a benefit over discrete transistor voltage translation solutions, since the fabrication of the switch is symmetrical. The translator provides excellent ESD protection to lower voltage devices, and at the same time protects less ESD-resistant devices.

### 2. Features and benefits

---

- Provides bidirectional voltage translation with no direction pin
- Less than 1.5 ns maximum propagation delay
- Allows voltage level translation between:
  - ◆ 1.0 V  $V_{\text{ref(A)}}$  and 1.8 V, 2.5 V, 3.3 V or 5 V  $V_{\text{ref(B)}}$
  - ◆ 1.2 V  $V_{\text{ref(A)}}$  and 1.8 V, 2.5 V, 3.3 V or 5 V  $V_{\text{ref(B)}}$
  - ◆ 1.8 V  $V_{\text{ref(A)}}$  and 3.3 V or 5 V  $V_{\text{ref(B)}}$
  - ◆ 2.5 V  $V_{\text{ref(A)}}$  and 5 V  $V_{\text{ref(B)}}$
  - ◆ 3.3 V  $V_{\text{ref(A)}}$  and 5 V  $V_{\text{ref(B)}}$



- Low 3.5  $\Omega$  ON-state connection between input and output ports provides less signal distortion
- 5 V tolerant I/O ports to support mixed-mode signal operation
- High-impedance An and Bn pins for EN = LOW
- Lock-up free operation
- Flow through pinout for ease of printed-circuit board trace routing
- ESD protection exceeds 4 kV HBM per JESD22-A114 and 1000 V CDM per JESD22-C101

### 3. Ordering information

**Table 1. Ordering information**

$T_{amb} = -40\text{ }^{\circ}\text{C to }+105\text{ }^{\circ}\text{C}$ .

Type number	Topside marking	Number of bits	Package		
			Name	Description	Version
NVT2002DP <sup>[1]</sup>	N2002	2	TSSOP8	plastic thin shrink small outline package; 8 leads; body width 3 mm	SOT505-1
NVT2002GD	N02	2	XSON8U	plastic extremely thin small outline package; no leads; 8 terminals; UTLP based; body 3 × 2 × 0.5 mm	SOT996-2
NVT2001GM	N1	1	XSON6	plastic extremely thin small outline package; no leads; 6 terminals; body 1 × 1.45 × 0.5 mm	SOT886
NVT2001GM	T1	1	XSON6	plastic extremely thin small outline package; no leads; 6 terminals; body 1 × 1.45 × 0.5 mm; requires SSB	SOT886

[1] GTL2002DP = NVT2002DP.

#### 3.1 Ordering options

**Table 2. Ordering options**

Type number	Orderable part number	Package	Packing method	Minimum order quantity	Temperature
NVT2002DP	NVT2002DP,118	TSSOP8	Reel 13" Q1/T1 *Standard mark SMD	2500	$T_{amb} = -40\text{ }^{\circ}\text{C to }+105\text{ }^{\circ}\text{C}$
NVT2002GD	NVT2002GD,125	XSON8U	Reel 7" Q3/T4 *Standard mark	3000	$T_{amb} = -40\text{ }^{\circ}\text{C to }+105\text{ }^{\circ}\text{C}$
NVT2001GM	NVT2001GM,115 <sup>[1]</sup>	XSON6	Reel 7" Q1/T1 *Standard mark SMD	5000	$T_{amb} = -40\text{ }^{\circ}\text{C to }+105\text{ }^{\circ}\text{C}$
NVT2001GM	NVT2001GMZ	XSON6	Reel 7" Q1/T1 *Standard mark SMD SSB <sup>[2]</sup>	5000	$T_{amb} = -40\text{ }^{\circ}\text{C to }+105\text{ }^{\circ}\text{C}$

[1] Will go EOL - migrate to new leadframe orderable part number NVT2001GMZ.

[2] This packing method uses a Static Shielding Bag (SSB) solution. Material is to be kept in the sealed bag between uses.

## 4. Functional diagram

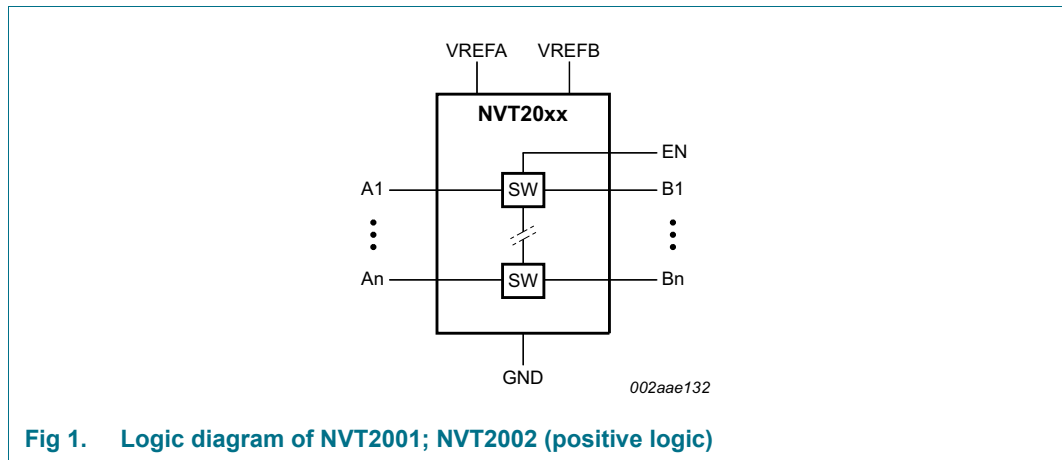

Fig 1. Logic diagram of NVT2001; NVT2002 (positive logic)

## 5. Pinning information

### 5.1 Pinning

#### 5.1.1 1-bit in XSON6 package

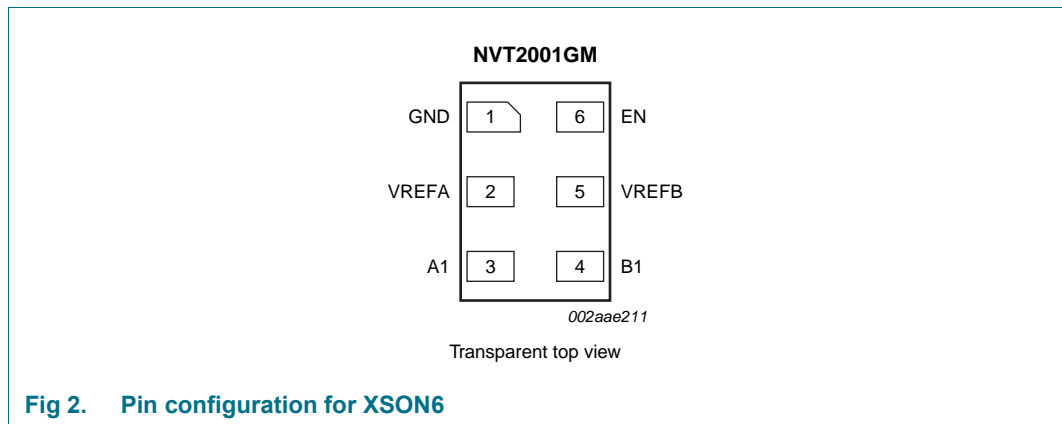

Fig 2. Pin configuration for XSON6

#### 5.1.2 2-bit in TSSOP8 and XSON8U packages

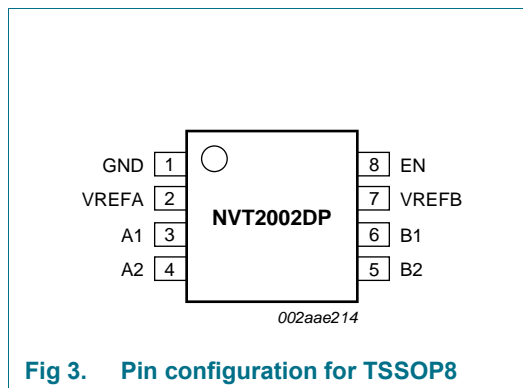

Fig 3. Pin configuration for TSSOP8

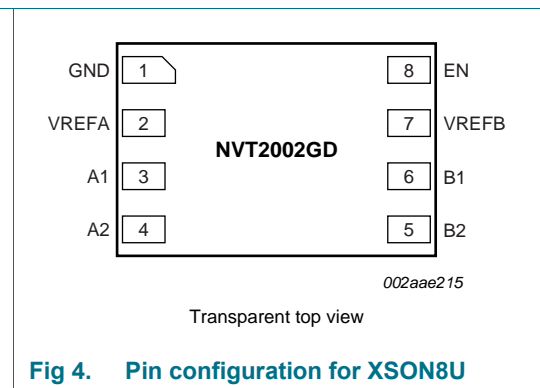

Fig 4. Pin configuration for XSON8U

## 5.2 Pin description

Table 3. Pin description

Symbol	Pin		Description
	NVT2001[1]	NVT2002[2]	
GND	1	1	ground (0 V)
VREFA	2	2	low-voltage side reference supply voltage for An
A1	3	3	low-voltage side; connect to VREFA through a pull-up resistor
A2	-	4	
B1	4	6	high-voltage side; connect to VREFB through a pull-up resistor
B2	-	5	
VREFB	5	7	high-voltage side reference supply voltage for Bn
EN	6	8	switch enable input; connect to VREFB and pull-up through a high resistor

[1] 1-bit NVT2001 available in XSON6 package.

[2] 2-bit NVT2002 available in TSSOP8 and XSON8U packages.

## 6. Functional description

Refer to [Figure 1 “Logic diagram of NVT2001; NVT2002 \(positive logic\)”](#).

### 6.1 Function table

Table 4. Function selection (example)

*H = HIGH level; L = LOW level.*

Input EN[1]	Function
H	An = Bn
L	disconnect

[1] EN is controlled by the  $V_{ref(B)}$  logic levels and should be at least 1 V higher than  $V_{ref(A)}$  for best translator operation.

## 7. Application design-in information

The NVT2001/02 can be used in level translation applications for interfacing devices or systems operating at different interface voltages with one another. The NVT2001/02 is ideal for use in applications where an open-drain driver is connected to the data I/Os. The NVT2001/02 can also be used in applications where a push-pull driver is connected to the data I/Os.

### 7.1 Enable and disable

The NVT20xx has an EN input that is used to disable the device by setting EN LOW, which places all I/Os in the high-impedance state.

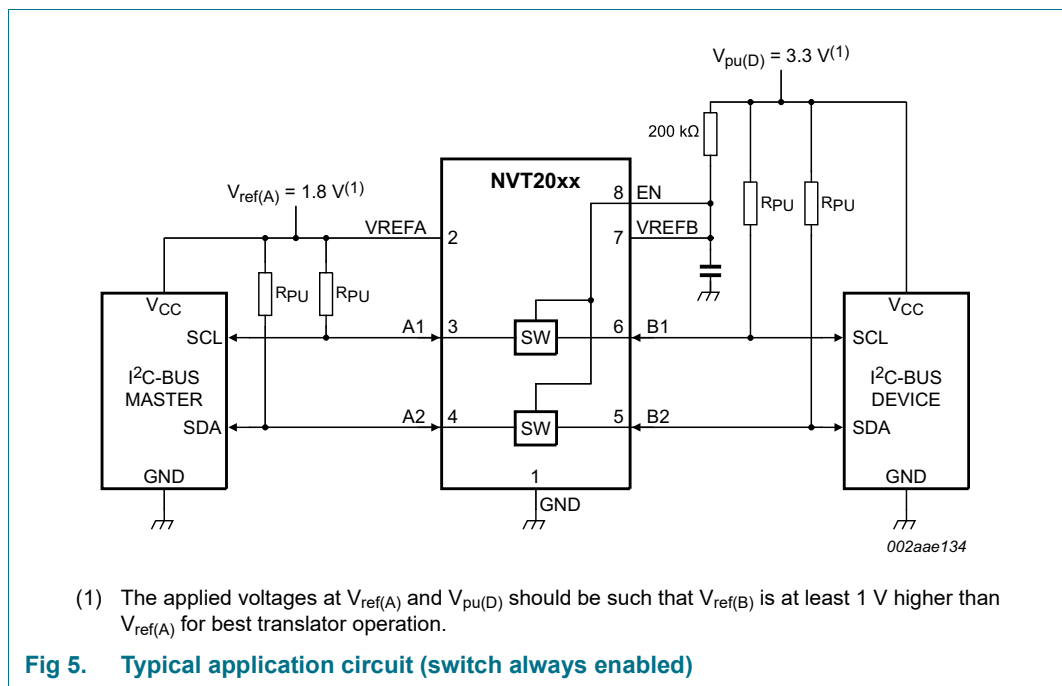

Fig 5. Typical application circuit (switch always enabled)

Table 5. Application operating conditions

Refer to [Figure 5](#).

Symbol	Parameter	Conditions	Min	Typ <sup>[1]</sup>	Max	Unit
$V_{ref(B)}$	reference voltage (B)		$V_{ref(A)} + 0.6$	2.1	5	V
$V_{I(EN)}$	input voltage on pin EN		$V_{ref(A)} + 0.6$	2.1	5	V
$V_{ref(A)}$	reference voltage (A)		0	1.5	4.4	V
$I_{sw(pass)}$	pass switch current		-	14	-	mA
$I_{ref}$	reference current	transistor	-	5	-	$\mu$ A
$T_{amb}$	ambient temperature	operating in free-air	-40	-	+105	$^{\circ}$ C

[1] All typical values are at  $T_{amb} = 25^{\circ}$ C.

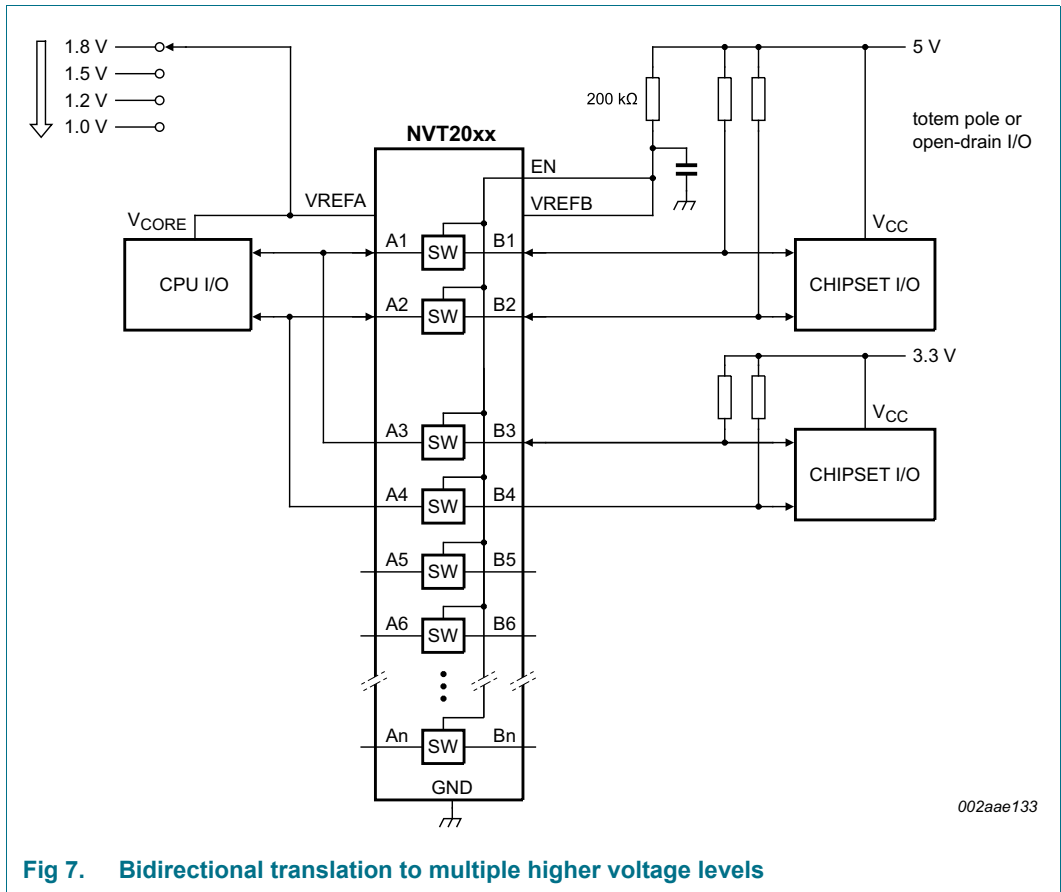
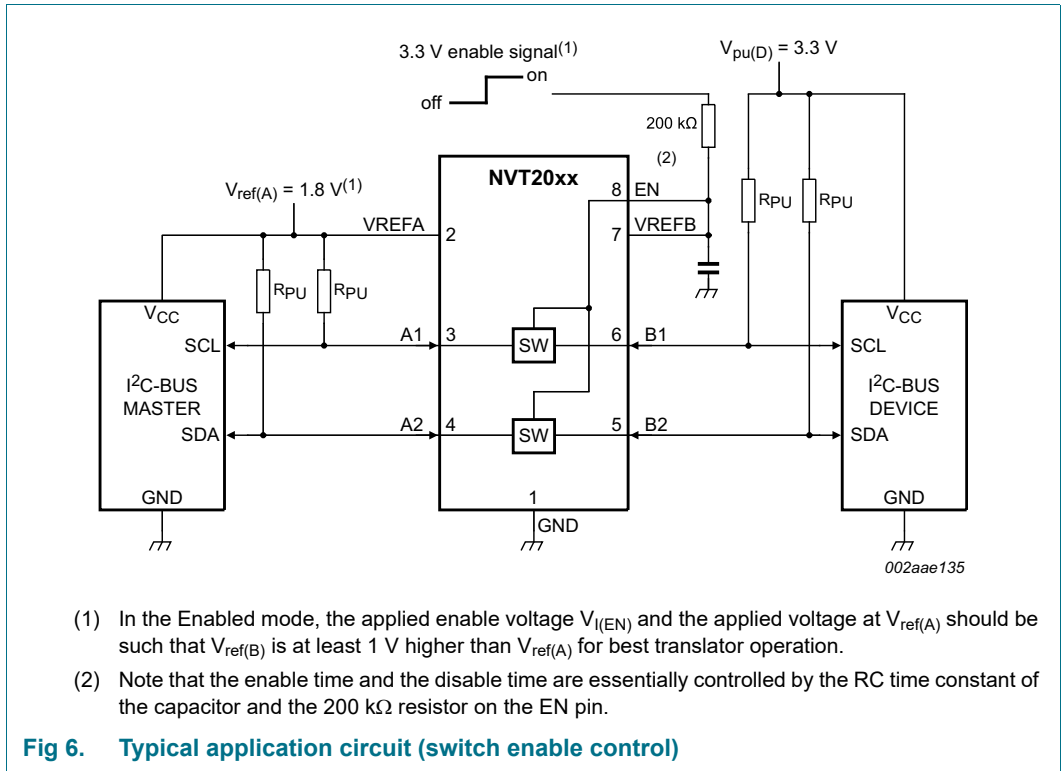

## 7.2 Bidirectional translation

For the bidirectional clamping configuration (higher voltage to lower voltage or lower voltage to higher voltage), the EN input must be connected to VREFB and both pins pulled to HIGH side  $V_{pu(D)}$  through a pull-up resistor (typically 200 k $\Omega$ ). This allows VREFB to regulate the EN input. A filter capacitor on VREFB is recommended. The master output driver can be totem pole or open-drain (pull-up resistors may be required) and the slave device output can be totem pole or open-drain (pull-up resistors are required to pull the Bn outputs to  $V_{pu(D)}$ ). However, if either output is totem-pole, data must be unidirectional or the outputs must be 3-stateable and be controlled by some direction-control mechanism to prevent HIGH-to-LOW contentions in either direction. If both outputs are open-drain, no direction control is needed.

The reference supply voltage ( $V_{ref(A)}$ ) is connected to the processor core power supply voltage. When VREFB is connected through a 200 k $\Omega$  resistor to a 3.3 V to 5.5 V  $V_{pu(D)}$  power supply, and  $V_{ref(A)}$  is set between 1.0 V and ( $V_{pu(D)} - 1$  V), the output of each An has a maximum output voltage equal to VREFB, and the output of each Bn has a maximum output voltage equal to  $V_{pu(D)}$ .

## 7.3 How to size pull-up resistor value

Sizing the pull-up resistor on an open-drain bus is specific to the individual application and is dependent on the following driver characteristics:

- The driver sink current
- The  $V_{OL}$  of driver
- The  $V_{IL}$  of the driver
- Frequency of operation

The following tables can be used to estimate the pull-up resistor value in different use cases so that the minimum resistance for the pull-up resistor can be found.

[Table 6](#), [Table 7](#) and [Table 8](#) contain suggested minimum values of pull-up resistors for the PCA9306 and NVT20xx devices with typical voltage translation levels and drive currents. The calculated values assume that both drive currents are the same.  $V_{OL} = V_{IL} = 0.1 \times V_{CC}$  and accounts for a  $\pm 5\%$   $V_{CC}$  tolerance of the supplies,  $\pm 1\%$  resistor values. It should be noted that the resistor chosen in the final application should be equal to or larger than the values shown in [Table 6](#), [Table 7](#) and [Table 8](#) to ensure that the pass voltage is less than 10 % of the  $V_{CC}$  voltage, and the external driver should be able to sink the total current from both pull-up resistors. When selecting the minimum resistor value in [Table 6](#), [Table 7](#) or [Table 8](#), the drive current strength that should be chosen should be the lowest drive current seen in the application and account for any drive strength current scaling with output voltage. For the GTL devices, the resistance table should be recalculated to account for the difference in ON resistance and bias voltage limitations between  $V_{CC(B)}$  and  $V_{CC(A)}$ .

Table 6. Pull-up resistor minimum values, 3 mA driver sink current for PCA9306 and NVT20xx

A-side	B-side					
	1.2 V	1.5 V	1.8 V	2.5 V	3.3 V	5.0 V
1.0 V	$R_{pu(A)} = 750 \Omega$ $R_{pu(B)} = 750 \Omega$	$R_{pu(A)} = 845 \Omega$ $R_{pu(B)} = 845 \Omega$	$R_{pu(A)} = 976 \Omega$ $R_{pu(B)} = 976 \Omega$	$R_{pu(A)} = \text{none}$ $R_{pu(B)} = 887 \Omega$	$R_{pu(A)} = \text{none}$ $R_{pu(B)} = 1.18 \text{ k}\Omega$	$R_{pu(A)} = \text{none}$ $R_{pu(B)} = 1.82 \text{ k}\Omega$
1.2 V		$R_{pu(A)} = 931 \Omega$ $R_{pu(B)} = 931 \Omega$	$R_{pu(A)} = 1.02 \text{ k}\Omega$ $R_{pu(B)} = 1.02 \text{ k}\Omega$	$R_{pu(A)} = \text{none}$ $R_{pu(B)} = 887 \Omega$	$R_{pu(A)} = \text{none}$ $R_{pu(B)} = 1.18 \text{ k}\Omega$	$R_{pu(A)} = \text{none}$ $R_{pu(B)} = 1.82 \text{ k}\Omega$
1.5 V			$R_{pu(A)} = 1.1 \text{ k}\Omega$ $R_{pu(B)} = 1.1 \text{ k}\Omega$	$R_{pu(A)} = \text{none}$ $R_{pu(B)} = 866 \Omega$	$R_{pu(A)} = \text{none}$ $R_{pu(B)} = 1.18 \text{ k}\Omega$	$R_{pu(A)} = \text{none}$ $R_{pu(B)} = 1.78 \text{ k}\Omega$
1.8 V				$R_{pu(A)} = 1.47 \text{ k}\Omega$ $R_{pu(B)} = 1.47 \text{ k}\Omega$	$R_{pu(A)} = \text{none}$ $R_{pu(B)} = 1.15 \text{ k}\Omega$	$R_{pu(A)} = \text{none}$ $R_{pu(B)} = 1.78 \text{ k}\Omega$
2.5 V					$R_{pu(A)} = 1.96 \text{ k}\Omega$ $R_{pu(B)} = 1.96 \text{ k}\Omega$	$R_{pu(A)} = \text{none}$ $R_{pu(B)} = 1.78 \text{ k}\Omega$
3.3 V						$R_{pu(A)} = \text{none}$ $R_{pu(B)} = 1.74 \text{ k}\Omega$

Table 7. Pull-up resistor minimum values, 10 mA driver sink current for PCA9306 and NVT20xx

A-side	B-side					
	1.2 V	1.5 V	1.8 V	2.5 V	3.3 V	5.0 V
1.0 V	$R_{pu(A)} = 221 \Omega$ $R_{pu(B)} = 221 \Omega$	$R_{pu(A)} = 255 \Omega$ $R_{pu(B)} = 255 \Omega$	$R_{pu(A)} = 287 \Omega$ $R_{pu(B)} = 287 \Omega$	$R_{pu(A)} = \text{none}$ $R_{pu(B)} = 267 \Omega$	$R_{pu(A)} = \text{none}$ $R_{pu(B)} = 357 \Omega$	$R_{pu(A)} = \text{none}$ $R_{pu(B)} = 549 \Omega$
1.2 V		$R_{pu(A)} = 274 \Omega$ $R_{pu(B)} = 274 \Omega$	$R_{pu(A)} = 309 \Omega$ $R_{pu(B)} = 309 \Omega$	$R_{pu(A)} = \text{none}$ $R_{pu(B)} = 267 \Omega$	$R_{pu(A)} = \text{none}$ $R_{pu(B)} = 357 \Omega$	$R_{pu(A)} = \text{none}$ $R_{pu(B)} = 549 \Omega$
1.5 V			$R_{pu(A)} = 332 \Omega$ $R_{pu(B)} = 332 \Omega$	$R_{pu(A)} = \text{none}$ $R_{pu(B)} = 261 \Omega$	$R_{pu(A)} = \text{none}$ $R_{pu(B)} = 348 \Omega$	$R_{pu(A)} = \text{none}$ $R_{pu(B)} = 536 \Omega$
1.8 V				$R_{pu(A)} = 442 \Omega$ $R_{pu(B)} = 442 \Omega$	$R_{pu(A)} = \text{none}$ $R_{pu(B)} = 348 \Omega$	$R_{pu(A)} = \text{none}$ $R_{pu(B)} = 536 \Omega$
2.5 V					$R_{pu(A)} = 590 \Omega$ $R_{pu(B)} = 590 \Omega$	$R_{pu(A)} = \text{none}$ $R_{pu(B)} = 523 \Omega$
3.3 V						$R_{pu(A)} = \text{none}$ $R_{pu(B)} = 523 \Omega$



Table 8. Pull-up resistor minimum values, 15 mA driver sink current for PCA9306 and NVT20xx

A-side	B-side					
	1.2 V	1.5 V	1.8 V	2.5 V	3.3 V	5.0 V
1.0 V	R <sub>pu(A)</sub> = 147 Ω R <sub>pu(B)</sub> = 147 Ω	R <sub>pu(A)</sub> = 169 Ω R <sub>pu(B)</sub> = 169 Ω	R <sub>pu(A)</sub> = 191 Ω R <sub>pu(B)</sub> = 191 Ω	R <sub>pu(A)</sub> = none R <sub>pu(B)</sub> = 178 Ω	R <sub>pu(A)</sub> = none R <sub>pu(B)</sub> = 237 Ω	R <sub>pu(A)</sub> = none R <sub>pu(B)</sub> = 365 Ω
1.2 V		R <sub>pu(A)</sub> = 182 Ω R <sub>pu(B)</sub> = 182 Ω	R <sub>pu(A)</sub> = 205 Ω R <sub>pu(B)</sub> = 205 Ω	R <sub>pu(A)</sub> = none R <sub>pu(B)</sub> = 178 Ω	R <sub>pu(A)</sub> = none R <sub>pu(B)</sub> = 237 Ω	R <sub>pu(A)</sub> = none R <sub>pu(B)</sub> = 365 Ω
1.5 V			R <sub>pu(A)</sub> = 221 Ω R <sub>pu(B)</sub> = 221 Ω	R <sub>pu(A)</sub> = none R <sub>pu(B)</sub> = 174 Ω	R <sub>pu(A)</sub> = none R <sub>pu(B)</sub> = 232 Ω	R <sub>pu(A)</sub> = none R <sub>pu(B)</sub> = 357 Ω
1.8 V				R <sub>pu(A)</sub> = 294 Ω R <sub>pu(B)</sub> = 294 Ω	R <sub>pu(A)</sub> = none R <sub>pu(B)</sub> = 232 Ω	R <sub>pu(A)</sub> = none R <sub>pu(B)</sub> = 357 Ω
2.5 V					R <sub>pu(A)</sub> = 392 Ω R <sub>pu(B)</sub> = 392 Ω	R <sub>pu(A)</sub> = none R <sub>pu(B)</sub> = 357 Ω
3.3 V						R <sub>pu(A)</sub> = none R <sub>pu(B)</sub> = 348 Ω

### 7.4 How to design for maximum frequency operation

The maximum frequency is limited by the minimum pulse width LOW and HIGH as well as rise time and fall time. See Equation 1 as an example of the maximum frequency. The rise and fall times are shown in Figure 8.

$$f_{max} = \frac{1}{t_{LOW(min)} + t_{HIGH(min)} + t_{r(actual)} + t_{f(actual)}} \tag{1}$$

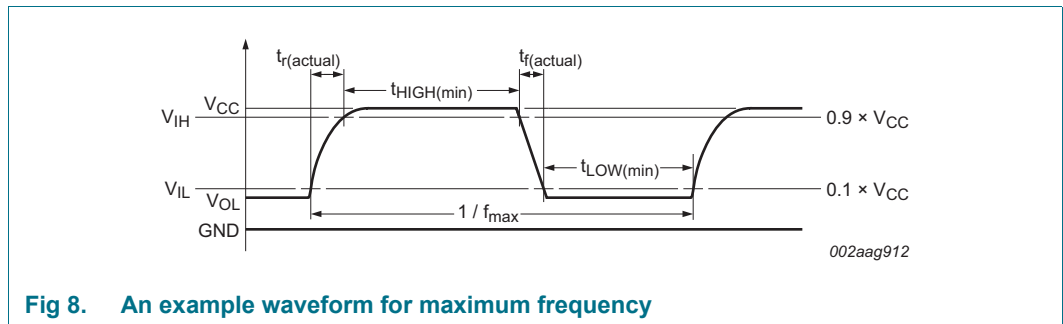

Fig 8. An example waveform for maximum frequency

The rise and fall times are dependent upon translation voltages, the drive strength, the total node capacitance (C<sub>L(tot)</sub>) and the pull-up resistors (R<sub>PU</sub>) that are present on the bus. The node capacitance is the addition of the PCB trace capacitance and the device capacitance that exists on the bus. Because of the dependency of the external components, PCB layout and the different device operating states the calculation of rise and fall times is complex and has several inflection points along the curve.

The main component of the rise and fall times is the RC time constant of the bus line when the device is in its two primary operating states: when device is in the ON state and it is low-impedance, the other is when the device is OFF isolating the A-side from the B-side.

A description of the fall time applied to either An or Bn output going from HIGH to LOW is as follows. Whichever side is asserted first, the B-side down must discharge to the V<sub>CC(A)</sub> voltage. The time is determined by the pull-up resistor, pull-down driver strength and the

capacitance. As the level moves below the  $V_{CC(A)}$  voltage, the channel resistance drops so that both A and B sides equal. The capacitance on both sides is connected to form the total capacitance and the pull-up resistors on both sides combine to the parallel equivalent resistance. The  $R_{on}$  of the device is small compared to the pull-up resistor values, so its effect on the pull-up resistance can be neglected and the fall is determined by the driver pulling the combined capacitance and pull-up resistor currents. An estimation of the actual fall time seen by the device is equal to the time it takes for the B-side to fall to the  $V_{CC(A)}$  voltage and the time it takes for both sides to fall from the  $V_{CC(A)}$  voltage to the  $V_{IL}$  level.

A description of the rise time applied to either An or Bn output going from LOW to HIGH is as follows. When the signal level is LOW, the  $R_{on}$  is at its minimum, so the A and B sides are essentially one node. They will rise together with an RC time constant that is the sum of all the capacitance from both sides and the parallel of the resistance from both sides. As the signal approaches the  $V_{CC(A)}$  voltage, the channel resistance goes up and the waveforms separate, with the B side finishing its rise with the RC time constant of the B side. The rise to  $V_{CC(A)}$  is essentially the same for both sides.

There are some basic guidelines to follow that will help maximize the performance of the device:

- Keep trace length to a minimum by placing the NVT device close to the processor.
- The signal round trip time on trace should be shorter than the rise or fall time of signal to reduce reflections.
- The faster the edge of the signal, the higher the chance for ringing.
- The higher drive strength controlled by the pull-up resistor (up to 15 mA), the higher the frequency the device can use.

The system designer must design the pull-up resistor value based on external current drive strength and limit the node capacitance (minimize the wire, stub, connector and trace length) to get the desired operation frequency result.

## 8. Limiting values

**Table 9. Limiting values**

*In accordance with the Absolute Maximum Rating System (IEC 60134).  
Over operating free-air temperature range.*

Symbol	Parameter	Conditions	Min	Max	Unit
$V_{ref(A)}$	reference voltage (A)		-0.5	+6	V
$V_{ref(B)}$	reference voltage (B)		-0.5	+6	V
$V_I$	input voltage		-0.5 <sup>[1]</sup>	+6	V
$V_{I/O}$	voltage on an input/output pin		-0.5 <sup>[1]</sup>	+6	V
$I_{ch}$	channel current (DC)		-	128	mA
$I_{IK}$	input clamping current	$V_I < 0$ V	-50	-	mA
$I_{OK}$	output clamping current		<sup>[2]</sup> -50	+50	mA
$T_{stg}$	storage temperature		-65	+150	°C

[1] The input and input/output negative voltage ratings may be exceeded if the input and input/output clamp current ratings are observed.

[2] Low duty cycle pulses, not DC because of heating.

## 9. Recommended operating conditions

**Table 10. Operating conditions**

Symbol	Parameter	Conditions	Min	Max	Unit
$V_{I/O}$	voltage on an input/output pin	An, Bn	0	5.5	V
$V_{ref(A)}$	reference voltage (A)	VREFA	[1] 0	5.4	V
$V_{ref(B)}$	reference voltage (B)	VREFB	[1] 0	5.5	V
$V_{I(EN)}$	input voltage on pin EN		0	5.5	V
$I_{sw(pass)}$	pass switch current		-	64	mA
$T_{amb}$	ambient temperature	operating in free-air	-40	+105	°C

[1]  $V_{ref(A)} \leq V_{ref(B)} - 1$  V for best results in level shifting applications.

## 10. Static characteristics

**Table 11. Static characteristics**

$T_{amb} = -40$  °C to  $+105$  °C, unless otherwise specified.

Symbol	Parameter	Conditions	Min	Typ <sup>[1]</sup>	Max	Unit
$V_{IK}$	input clamping voltage	$I_I = -18$ mA; $V_{I(EN)} = 0$ V	-	-	-1.2	V
$I_{IH}$	HIGH-level input current	$V_I = 5$ V; $V_{I(EN)} = 0$ V	-	-	5	μA
$C_{i(EN)}$	input capacitance on pin EN	$V_I = 3$ V or 0 V	-	7.1	-	pF
$C_{io(off)}$	off-state input/output capacitance	An, Bn; $V_O = 3$ V or 0 V; $V_{I(EN)} = 0$ V	-	4	6	pF
$C_{io(on)}$	on-state input/output capacitance	An, Bn; $V_O = 3$ V or 0 V; $V_{I(EN)} = 3$ V	-	9.3	12.5 <sup>[2]</sup>	pF
$R_{on}$	ON-state resistance	An, Bn; $V_I = 0$ V; $I_O = 64$ mA; $V_{I(EN)} = 4.5$ V	[3][4][5] 1	2.4	5.0	Ω
		$V_I = 2.4$ V; $I_O = 15$ mA; $V_{I(EN)} = 4.5$ V	[3][4] -	4.8	7.5	Ω

[1] All typical values are at  $T_{amb} = 25$  °C.

[2] Not production tested, maximum value based on characterization data of typical parts.

[3] Measured by the voltage drop between the An and Bn terminals at the indicated current through the switch. ON-state resistance is determined by the lowest voltage of the two terminals.

[4] See curves in [Figure 9](#) for typical temperature and  $V_{I(EN)}$  behavior.

[5] Guaranteed by design.

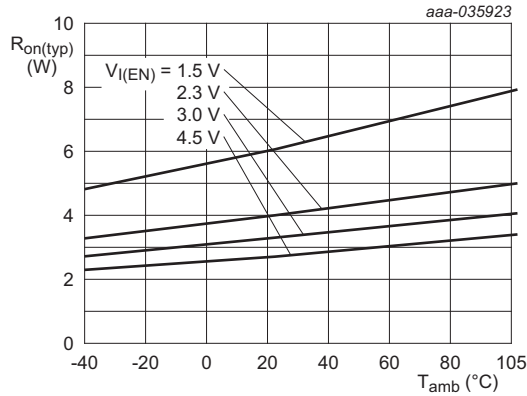

a.  $I_O = 64$  mA;  $V_I = 0$  V

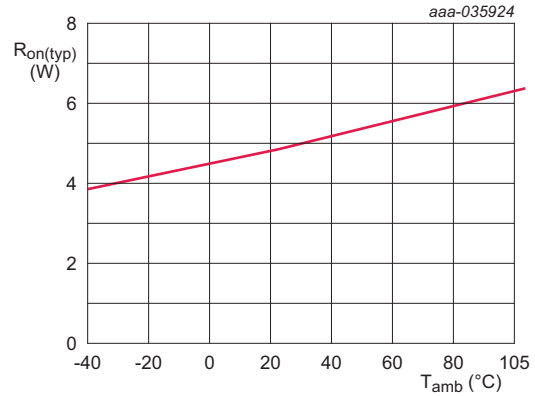

b.  $I_O = 15$  mA;  $V_I = 2.4$  V;  $V_{I(EN)} = 4.5$  V

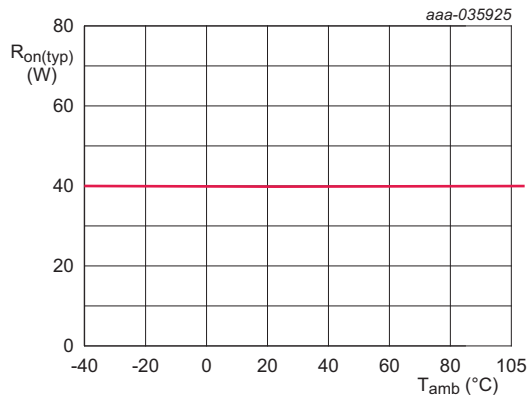

c.  $I_O = 15$  mA;  $V_I = 2.4$  V;  $V_{I(EN)} = 3.0$  V

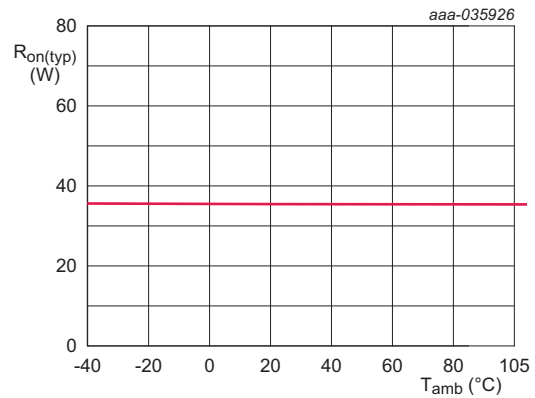

d.  $I_O = 15$  mA;  $V_I = 1.7$  V;  $V_{I(EN)} = 2.3$  V

**Fig 9. Typical ON-state resistance versus ambient temperature**

## 11. Dynamic characteristics

### 11.1 Open-drain drivers

**Table 12. Dynamic characteristics for open-drain drivers**

$T_{amb} = -40\text{ }^{\circ}\text{C}$  to  $+105\text{ }^{\circ}\text{C}$ ;  $V_{I(EN)} = V_{ref(B)}$ ;  $R_{bias(ext)} = 200\text{ k}\Omega$ ;  $C_{VREFB} = 0.1\text{ }\mu\text{F}$ ; unless otherwise specified.

Symbol	Parameter	Conditions	Min	Typ	Max	Unit
Refer to <a href="#">Figure 12</a>						
$t_{PLH}$	LOW to HIGH propagation delay	from (input) Bn to (output) An	[1]	$R_{on} \times (C_L + C_{io(on)})$		ns
$t_{PHL}$	HIGH to LOW propagation delay	from (input) Bn to (output) An		$R_{on} \times (C_L + C_{io(on)})$		ns

[1] See graphs based on  $R_{on}$  typical and  $C_{io(on)} + C_L = 50\text{ pF}$ .

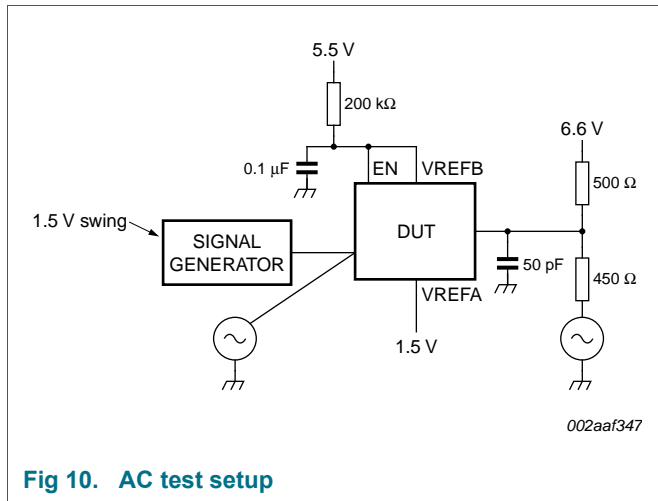

Fig 10. AC test setup

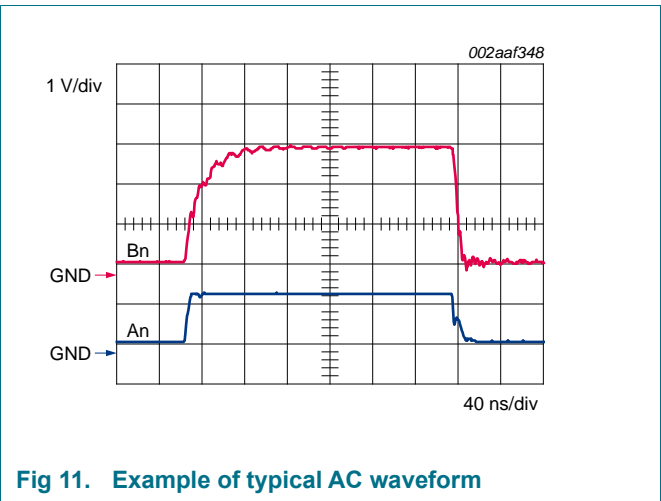

Fig 11. Example of typical AC waveform

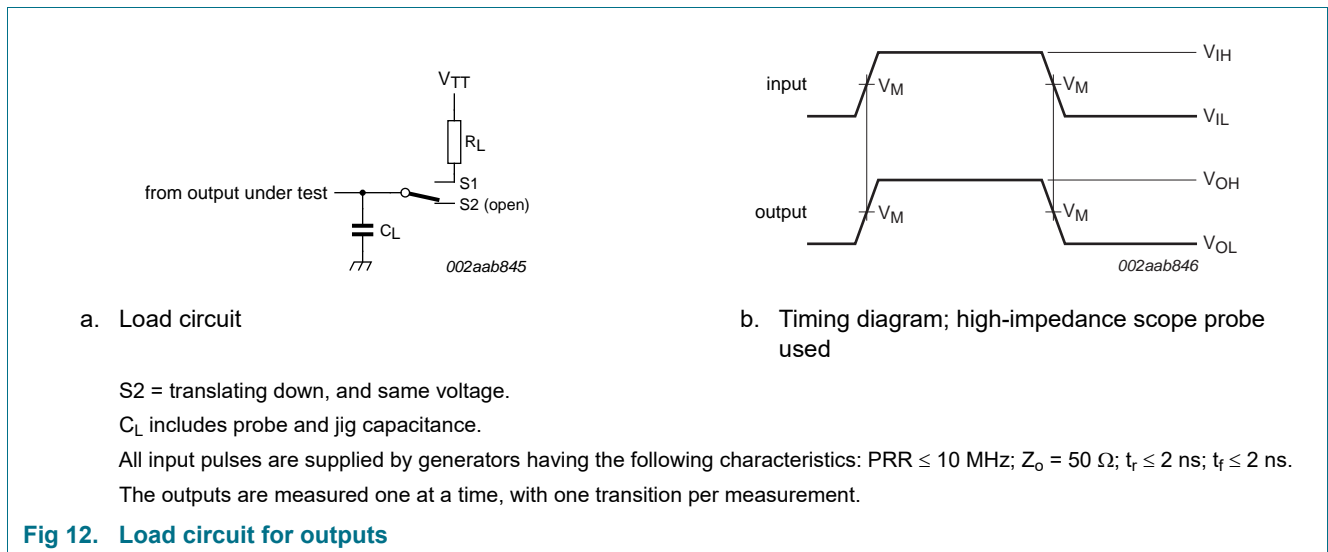

Fig 12. Load circuit for outputs

## 12. Performance curves

$t_{PLH}$  up-translation is typically dominated by the RC time constant, i.e.,  $C_{L(tot)} \times R_{PU} = 50 \text{ pF} \times 197 \text{ } \Omega = 9.85 \text{ ns}$ , but the  $R_{on} \times C_{L(tot)} = 50 \text{ pF} \times 5 \text{ } \Omega = 0.250 \text{ ns}$ .

$t_{PHL}$  is typically dominated by the external pull-down driver +  $R_{on}$ , which is typically small compared to the  $t_{PLH}$  in an up-translation case.

Enable/disable times are dominated by the RC time constant on the EN pin since the transistor turn off is on the order of ns, but the enable RC is on the order of ms.

Fall time is dominated by the external pull-down driver with only a slight  $R_{on}$  addition.

Rise time is dominated by the  $R_{PU} \times C_L$ .

Skew time within the part is virtually non-existent, dominated by the difference in bond wire lengths, which is typically small compared to the board-level routing differences.

Maximum data rate is dominated by the system capacitance and pull-up resistors.

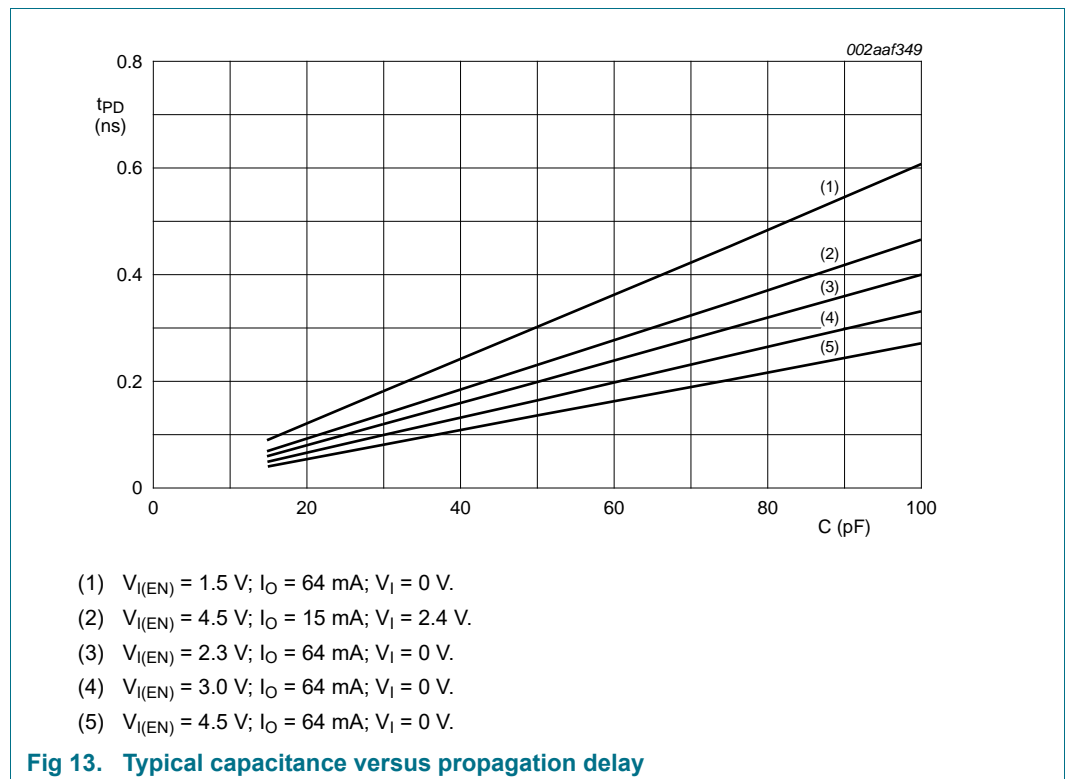

### 13. Package outline

XSON6: plastic extremely thin small outline package; no leads; 6 terminals; body 1 x 1.45 x 0.5 mm

SOT886

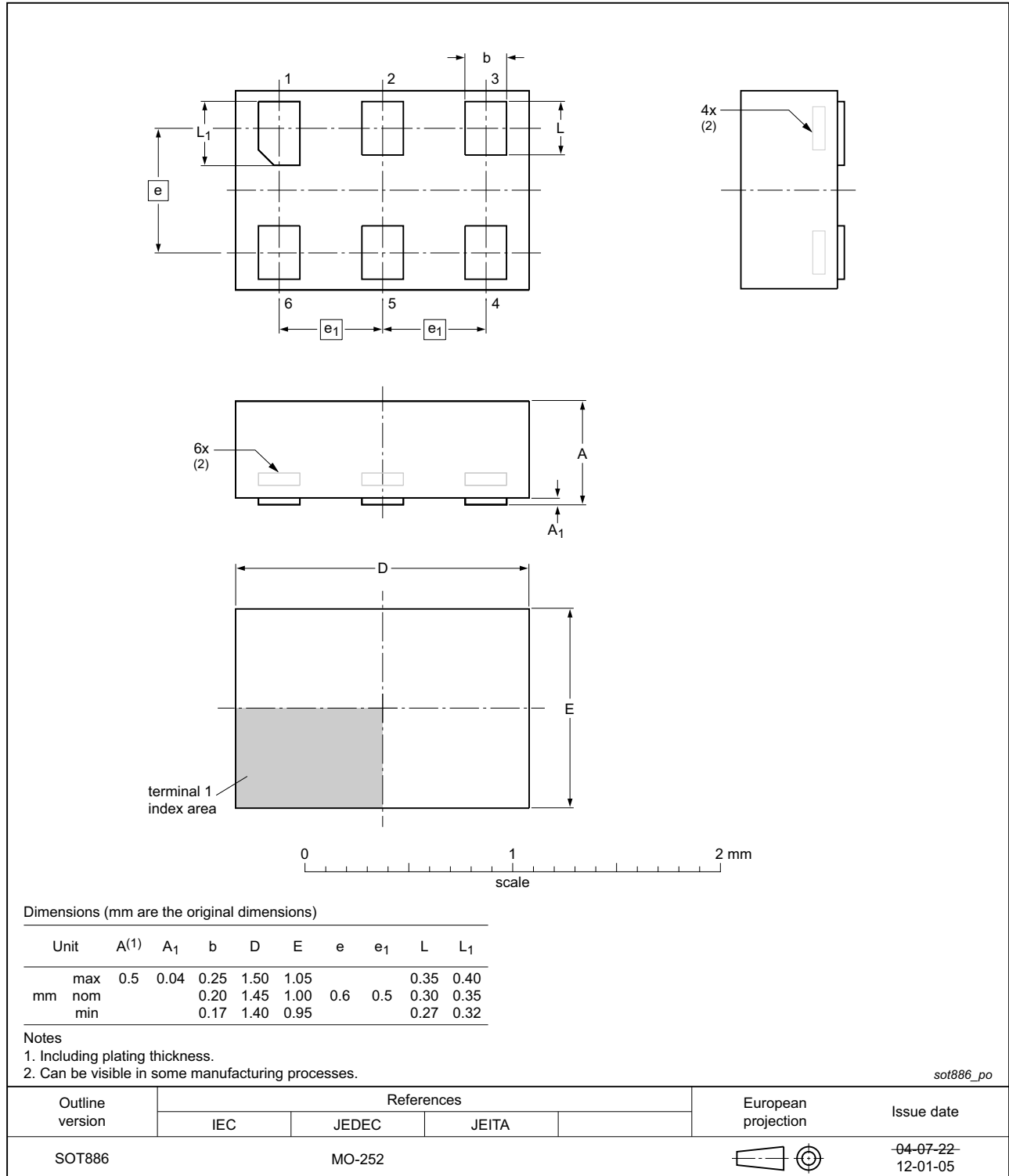

Fig 14. Package outline SOT886 (XSON6)

TSSOP8: plastic thin shrink small outline package; 8 leads; body width 3 mm

SOT505-1

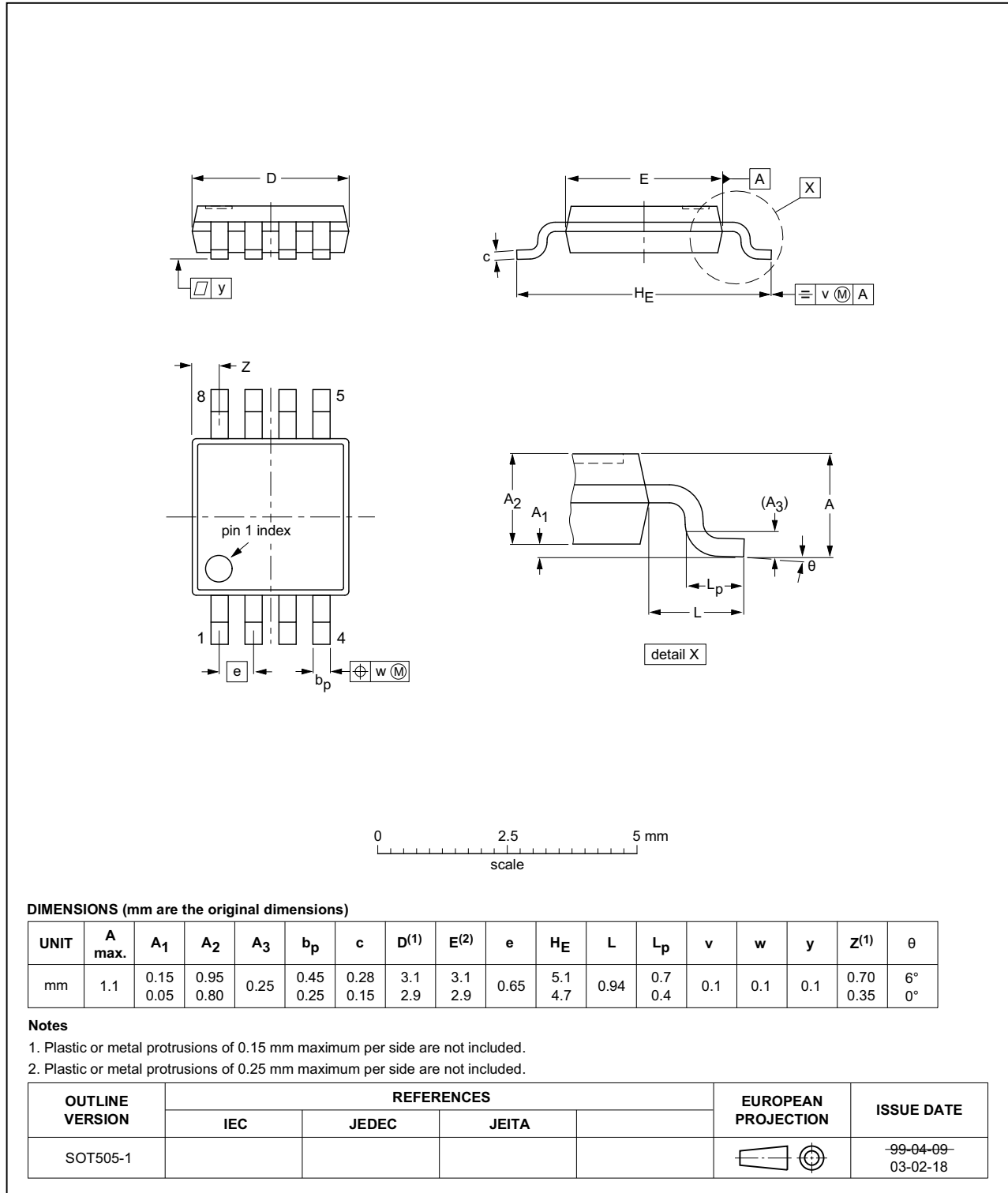

Fig 15. Package outline SOT505-1 (TSSOP8)



XSON8: plastic extremely thin small outline package; no leads;  
8 terminals; body 3 x 2 x 0.5 mm

SOT996-2

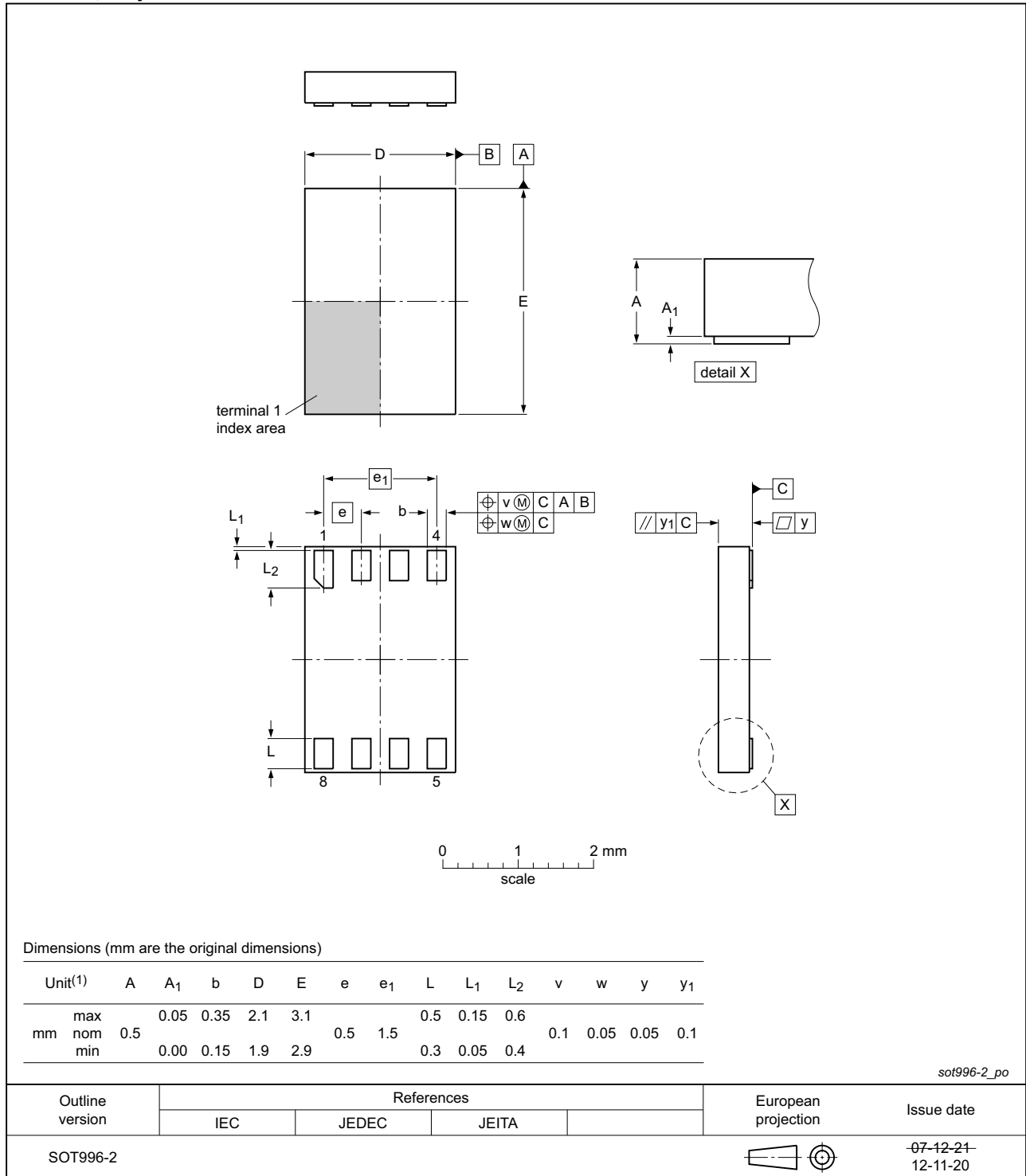

Fig 16. Package outline SOT996-2 (XSON8U)

## 14. Soldering of SMD packages

This text provides a very brief insight into a complex technology. A more in-depth account of soldering ICs can be found in Application Note *AN10365 “Surface mount reflow soldering description”*.

### 14.1 Introduction to soldering

Soldering is one of the most common methods through which packages are attached to Printed Circuit Boards (PCBs), to form electrical circuits. The soldered joint provides both the mechanical and the electrical connection. There is no single soldering method that is ideal for all IC packages. Wave soldering is often preferred when through-hole and Surface Mount Devices (SMDs) are mixed on one printed wiring board; however, it is not suitable for fine pitch SMDs. Reflow soldering is ideal for the small pitches and high densities that come with increased miniaturization.

### 14.2 Wave and reflow soldering

Wave soldering is a joining technology in which the joints are made by solder coming from a standing wave of liquid solder. The wave soldering process is suitable for the following:

- Through-hole components
- Leaded or leadless SMDs, which are glued to the surface of the printed circuit board

Not all SMDs can be wave soldered. Packages with solder balls, and some leadless packages which have solder lands underneath the body, cannot be wave soldered. Also, leaded SMDs with leads having a pitch smaller than ~0.6 mm cannot be wave soldered, due to an increased probability of bridging.

The reflow soldering process involves applying solder paste to a board, followed by component placement and exposure to a temperature profile. Leaded packages, packages with solder balls, and leadless packages are all reflow solderable.

Key characteristics in both wave and reflow soldering are:

- Board specifications, including the board finish, solder masks and vias
- Package footprints, including solder thieves and orientation
- The moisture sensitivity level of the packages
- Package placement
- Inspection and repair
- Lead-free soldering versus SnPb soldering

### 14.3 Wave soldering

Key characteristics in wave soldering are:

- Process issues, such as application of adhesive and flux, clinching of leads, board transport, the solder wave parameters, and the time during which components are exposed to the wave
- Solder bath specifications, including temperature and impurities

## 14.4 Reflow soldering

Key characteristics in reflow soldering are:

- Lead-free versus SnPb soldering; note that a lead-free reflow process usually leads to higher minimum peak temperatures (see [Figure 17](#)) than a SnPb process, thus reducing the process window
- Solder paste printing issues including smearing, release, and adjusting the process window for a mix of large and small components on one board
- Reflow temperature profile; this profile includes preheat, reflow (in which the board is heated to the peak temperature) and cooling down. It is imperative that the peak temperature is high enough for the solder to make reliable solder joints (a solder paste characteristic). In addition, the peak temperature must be low enough that the packages and/or boards are not damaged. The peak temperature of the package depends on package thickness and volume and is classified in accordance with [Table 13](#) and [14](#)

**Table 13. SnPb eutectic process (from J-STD-020D)**

Package thickness (mm)	Package reflow temperature (°C)	
	Volume (mm <sup>3</sup> )	
	< 350	≥ 350
< 2.5	235	220
≥ 2.5	220	220

**Table 14. Lead-free process (from J-STD-020D)**

Package thickness (mm)	Package reflow temperature (°C)		
	Volume (mm <sup>3</sup> )		
	< 350	350 to 2000	> 2000
< 1.6	260	260	260
1.6 to 2.5	260	250	245
> 2.5	250	245	245

Moisture sensitivity precautions, as indicated on the packing, must be respected at all times.

Studies have shown that small packages reach higher temperatures during reflow soldering, see [Figure 17](#).

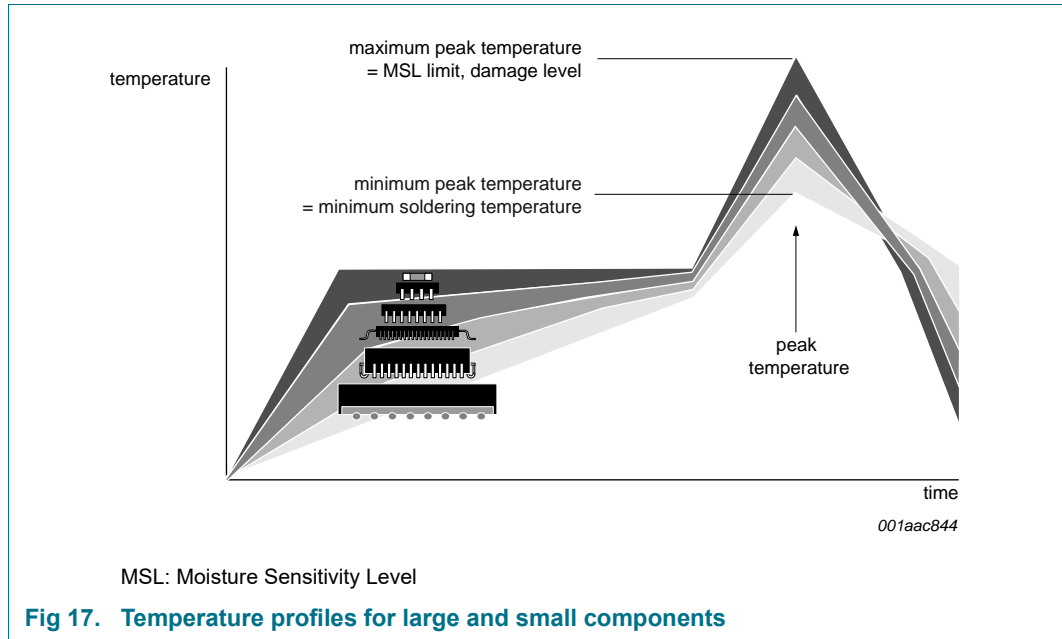

For further information on temperature profiles, refer to Application Note AN10365 “Surface mount reflow soldering description”.

## 15. Soldering: PCB footprints

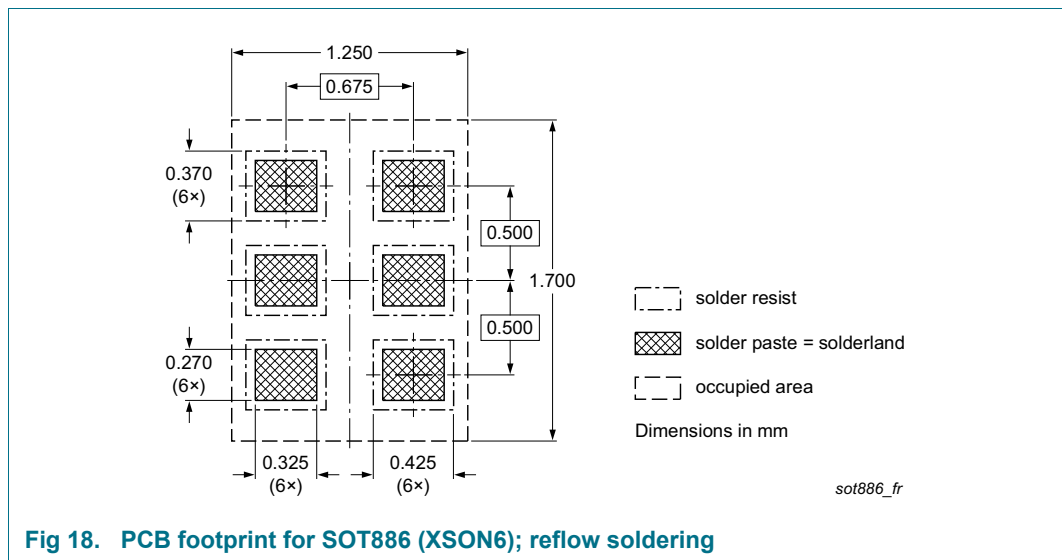

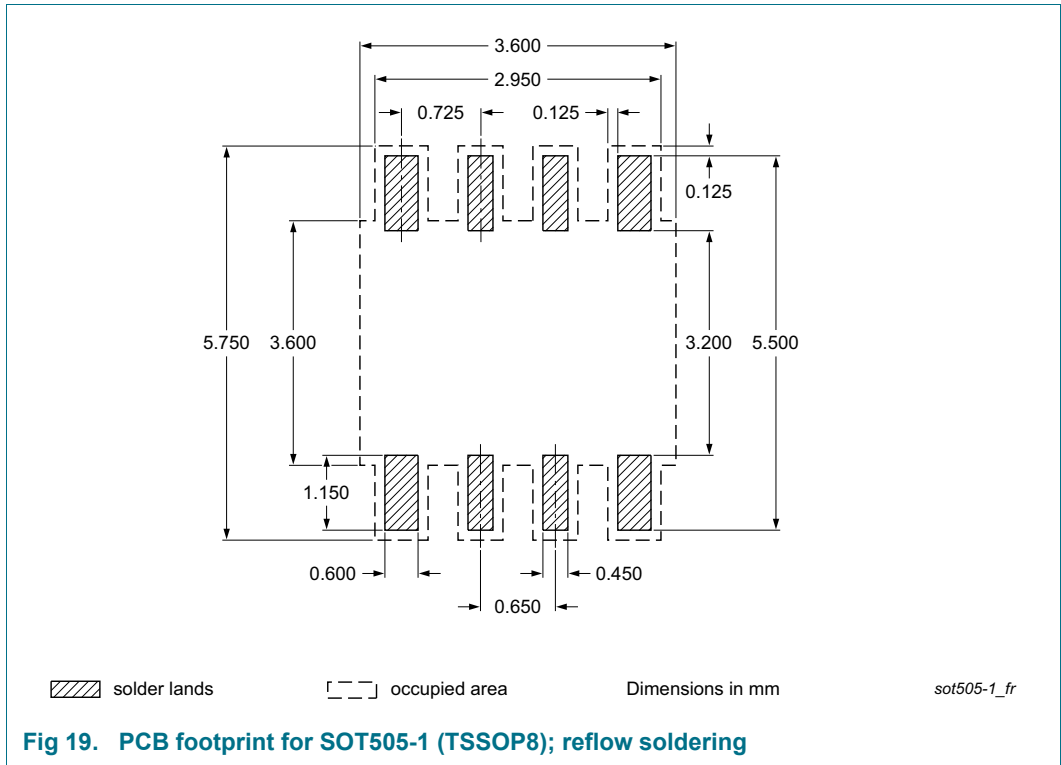

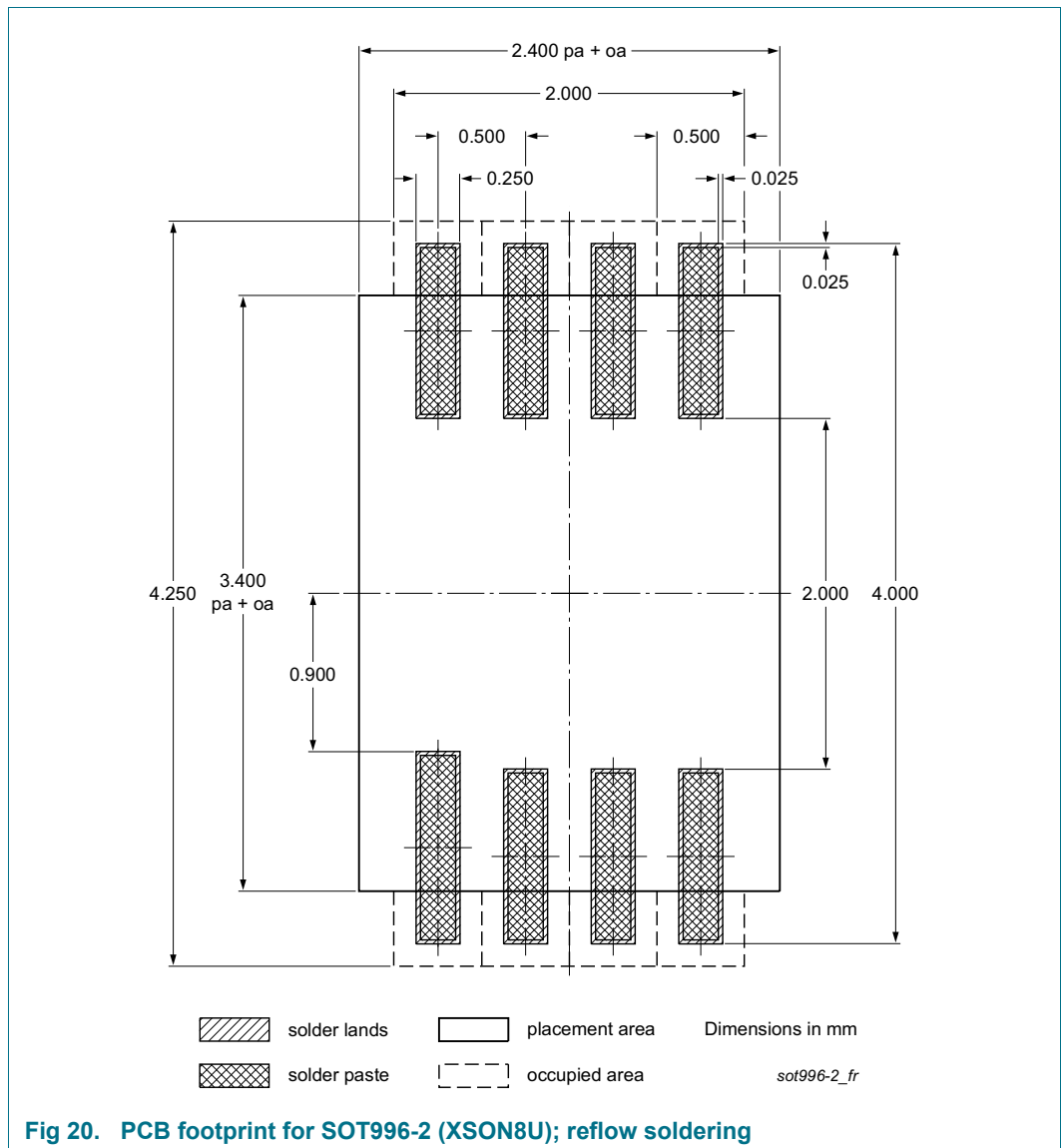

## 16. Abbreviations

Table 15. Abbreviations

Acronym	Description
CDM	Charged Device Model
ESD	ElectroStatic Discharge
GTL	Gunning Transceiver Logic
HBM	Human Body Model
I <sup>2</sup> C-bus	Inter-Integrated Circuit bus
I/O	Input/Output
LVTTL	Low Voltage Transistor-Transistor Logic
PRR	Pulse Repetition Rate
RC	Resistor-Capacitor network

## 17. Revision history

Table 16. Revision history

Document ID	Release date	Data sheet status	Change notice	Supersedes
NVT2001_NVT2002 v.4.1	20191206	Product data sheet	201909001A, 201912004I	NVT2001_NVT2002 v.4
Modifications:	<ul style="list-style-type: none"> <li>• Package SOT886 requiring SSB added. Refer to PCN number 201909001A XSON6 (SOT886) Assembly/Test Transfer from ATGD and ATSN to ATBK.</li> <li>• Corrected NVT2001GM topside mark N1X to N1. Only two characters allowed in Line 1 and there is no revolving date code.</li> <li>• Improved temperature range from “-40 °C to +85 °C” to “-40 °C to +105 °C”</li> </ul>			
NVT2001_NVT2002 v.4	20140127	Product data sheet	-	NVT2001_NVT2002 v.3
Modifications:	<ul style="list-style-type: none"> <li>• Added <a href="#">Section 3.1 “Ordering options”</a></li> <li>• Deleted (old) Section 7.3 “Sizing pull-up resistor”</li> <li>• Added (new) <a href="#">Section 7.3 “How to size pull-up resistor value”</a></li> <li>• Added (new) <a href="#">Section 7.4 “How to design for maximum frequency operation”</a></li> <li>• Added (new) <a href="#">Section 15 “Soldering: PCB footprints”</a></li> </ul>			
NVT2001_NVT2002 v.3	20120426	Product data sheet	-	NVT2001_NVT2002 v.2
NVT2001_NVT2002 v.2	20111026	Product data sheet	-	NVT2001_NVT2002 v.1
NVT2001_NVT2002 v.1	20100830	Product data sheet	-	-

## 18. Legal information

### 18.1 Data sheet status

Document status <sup>[1][2]</sup>	Product status <sup>[3]</sup>	Definition
Objective [short] data sheet	Development	This document contains data from the objective specification for product development.
Preliminary [short] data sheet	Qualification	This document contains data from the preliminary specification.
Product [short] data sheet	Production	This document contains the product specification.

[1] Please consult the most recently issued document before initiating or completing a design.

[2] The term 'short data sheet' is explained in section "Definitions".

[3] The product status of device(s) described in this document may have changed since this document was published and may differ in case of multiple devices. The latest product status information is available on the Internet at URL <http://www.nxp.com>.

### 18.2 Definitions

**Draft** — The document is a draft version only. The content is still under internal review and subject to formal approval, which may result in modifications or additions. NXP Semiconductors does not give any representations or warranties as to the accuracy or completeness of information included herein and shall have no liability for the consequences of use of such information.

**Short data sheet** — A short data sheet is an extract from a full data sheet with the same product type number(s) and title. A short data sheet is intended for quick reference only and should not be relied upon to contain detailed and full information. For detailed and full information see the relevant full data sheet, which is available on request via the local NXP Semiconductors sales office. In case of any inconsistency or conflict with the short data sheet, the full data sheet shall prevail.

**Product specification** — The information and data provided in a Product data sheet shall define the specification of the product as agreed between NXP Semiconductors and its customer, unless NXP Semiconductors and customer have explicitly agreed otherwise in writing. In no event however, shall an agreement be valid in which the NXP Semiconductors product is deemed to offer functions and qualities beyond those described in the Product data sheet.

### 18.3 Disclaimers

**Limited warranty and liability** — Information in this document is believed to be accurate and reliable. However, NXP Semiconductors does not give any representations or warranties, expressed or implied, as to the accuracy or completeness of such information and shall have no liability for the consequences of use of such information. NXP Semiconductors takes no responsibility for the content in this document if provided by an information source outside of NXP Semiconductors.

In no event shall NXP Semiconductors be liable for any indirect, incidental, punitive, special or consequential damages (including - without limitation - lost profits, lost savings, business interruption, costs related to the removal or replacement of any products or rework charges) whether or not such damages are based on tort (including negligence), warranty, breach of contract or any other legal theory.

Notwithstanding any damages that customer might incur for any reason whatsoever, NXP Semiconductors' aggregate and cumulative liability towards customer for the products described herein shall be limited in accordance with the *Terms and conditions of commercial sale* of NXP Semiconductors.

**Right to make changes** — NXP Semiconductors reserves the right to make changes to information published in this document, including without limitation specifications and product descriptions, at any time and without notice. This document supersedes and replaces all information supplied prior to the publication hereof.

**Suitability for use** — NXP Semiconductors products are not designed, authorized or warranted to be suitable for use in life support, life-critical or safety-critical systems or equipment, nor in applications where failure or malfunction of an NXP Semiconductors product can reasonably be expected to result in personal injury, death or severe property or environmental damage. NXP Semiconductors and its suppliers accept no liability for inclusion and/or use of NXP Semiconductors products in such equipment or applications and therefore such inclusion and/or use is at the customer's own risk.

**Applications** — Applications that are described herein for any of these products are for illustrative purposes only. NXP Semiconductors makes no representation or warranty that such applications will be suitable for the specified use without further testing or modification.

Customers are responsible for the design and operation of their applications and products using NXP Semiconductors products, and NXP Semiconductors accepts no liability for any assistance with applications or customer product design. It is customer's sole responsibility to determine whether the NXP Semiconductors product is suitable and fit for the customer's applications and products planned, as well as for the planned application and use of customer's third party customer(s). Customers should provide appropriate design and operating safeguards to minimize the risks associated with their applications and products.

NXP Semiconductors does not accept any liability related to any default, damage, costs or problem which is based on any weakness or default in the customer's applications or products, or the application or use by customer's third party customer(s). Customer is responsible for doing all necessary testing for the customer's applications and products using NXP Semiconductors products in order to avoid a default of the applications and the products or of the application or use by customer's third party customer(s). NXP does not accept any liability in this respect.

**Limiting values** — Stress above one or more limiting values (as defined in the Absolute Maximum Ratings System of IEC 60134) will cause permanent damage to the device. Limiting values are stress ratings only and (proper) operation of the device at these or any other conditions above those given in the Recommended operating conditions section (if present) or the Characteristics sections of this document is not warranted. Constant or repeated exposure to limiting values will permanently and irreversibly affect the quality and reliability of the device.

**Terms and conditions of commercial sale** — NXP Semiconductors products are sold subject to the general terms and conditions of commercial sale, as published at <http://www.nxp.com/profile/terms>, unless otherwise agreed in a valid written individual agreement. In case an individual agreement is concluded only the terms and conditions of the respective agreement shall apply. NXP Semiconductors hereby expressly objects to applying the customer's general terms and conditions with regard to the purchase of NXP Semiconductors products by customer.

**No offer to sell or license** — Nothing in this document may be interpreted or construed as an offer to sell products that is open for acceptance or the grant, conveyance or implication of any license under any copyrights, patents or other industrial or intellectual property rights.



**Export control** — This document as well as the item(s) described herein may be subject to export control regulations. Export might require a prior authorization from competent authorities.

**Non-automotive qualified products** — Unless this data sheet expressly states that this specific NXP Semiconductors product is automotive qualified, the product is not suitable for automotive use. It is neither qualified nor tested in accordance with automotive testing or application requirements. NXP Semiconductors accepts no liability for inclusion and/or use of non-automotive qualified products in automotive equipment or applications.

In the event that customer uses the product for design-in and use in automotive applications to automotive specifications and standards, customer (a) shall use the product without NXP Semiconductors' warranty of the product for such automotive applications, use and specifications, and (b) whenever customer uses the product for automotive applications beyond

NXP Semiconductors' specifications such use shall be solely at customer's own risk, and (c) customer fully indemnifies NXP Semiconductors for any liability, damages or failed product claims resulting from customer design and use of the product for automotive applications beyond NXP Semiconductors' standard warranty and NXP Semiconductors' product specifications.

**Translations** — A non-English (translated) version of a document is for reference only. The English version shall prevail in case of any discrepancy between the translated and English versions.

## 18.4 Trademarks

Notice: All referenced brands, product names, service names and trademarks are the property of their respective owners.

## 19. Contact information

For more information, please visit: <http://www.nxp.com>

For sales office addresses, please send an email to: [salesaddresses@nxp.com](mailto:salesaddresses@nxp.com)

## 20. Contents

<b>1</b>	<b>General description</b> . . . . .	<b>1</b>
<b>2</b>	<b>Features and benefits</b> . . . . .	<b>1</b>
<b>3</b>	<b>Ordering information</b> . . . . .	<b>2</b>
3.1	Ordering options . . . . .	2
<b>4</b>	<b>Functional diagram</b> . . . . .	<b>3</b>
<b>5</b>	<b>Pinning information</b> . . . . .	<b>3</b>
5.1	Pinning . . . . .	3
5.1.1	1-bit in XSON6 package . . . . .	3
5.1.2	2-bit in TSSOP8 and XSON8U packages . . . . .	3
5.2	Pin description . . . . .	4
<b>6</b>	<b>Functional description</b> . . . . .	<b>4</b>
6.1	Function table . . . . .	4
<b>7</b>	<b>Application design-in information</b> . . . . .	<b>5</b>
7.1	Enable and disable . . . . .	5
7.2	Bidirectional translation . . . . .	7
7.3	How to size pull-up resistor value . . . . .	7
7.4	How to design for maximum frequency operation 9	
<b>8</b>	<b>Limiting values</b> . . . . .	<b>10</b>
<b>9</b>	<b>Recommended operating conditions</b> . . . . .	<b>11</b>
<b>10</b>	<b>Static characteristics</b> . . . . .	<b>11</b>
<b>11</b>	<b>Dynamic characteristics</b> . . . . .	<b>13</b>
11.1	Open-drain drivers . . . . .	13
<b>12</b>	<b>Performance curves</b> . . . . .	<b>14</b>
<b>13</b>	<b>Package outline</b> . . . . .	<b>15</b>
<b>14</b>	<b>Soldering of SMD packages</b> . . . . .	<b>18</b>
14.1	Introduction to soldering . . . . .	18
14.2	Wave and reflow soldering . . . . .	18
14.3	Wave soldering . . . . .	18
14.4	Reflow soldering . . . . .	19
<b>15</b>	<b>Soldering: PCB footprints</b> . . . . .	<b>20</b>
<b>16</b>	<b>Abbreviations</b> . . . . .	<b>22</b>
<b>17</b>	<b>Revision history</b> . . . . .	<b>23</b>
<b>18</b>	<b>Legal information</b> . . . . .	<b>24</b>
18.1	Data sheet status . . . . .	24
18.2	Definitions . . . . .	24
18.3	Disclaimers . . . . .	24
18.4	Trademarks . . . . .	25
<b>19</b>	<b>Contact information</b> . . . . .	<b>25</b>
<b>20</b>	<b>Contents</b> . . . . .	<b>26</b>

Please be aware that important notices concerning this document and the product(s) described herein, have been included in section 'Legal information'.

© NXP B.V. 2020.

All rights reserved.

For more information, please visit: <http://www.nxp.com>

For sales office addresses, please send an email to: [salesaddresses@nxp.com](mailto:salesaddresses@nxp.com)

Date of release: 6 December 2019

Document identifier: NVT2001\_NVT2002

## X-ON Electronics

Largest Supplier of Electrical and Electronic Components

*Click to view similar products for [Translation - Voltage Levels](#) category:*

*Click to view products by [NXP](#) manufacturer:*

Other Similar products are found below :

[NLSX4373DMR2G](#) [NLSX5012MUTAG](#) [NLSX0102FCT2G](#) [NLSX4302EBMUTCG](#) [PCA9306FMUTAG](#) [MC100EPT622MNG](#)  
[NLSX5011MUTCG](#) [NLV9306USG](#) [NLVSX4014MUTAG](#) [NLSV4T3144MUTAG](#) [NLVSX4373MUTAG](#) [NB3U23CMNTAG](#)  
[MAX3371ELT+T](#) [NLSX3013BFCT1G](#) [NLV7WBD3125USG](#) [NLSX3012DMR2G](#) [74AVCH1T45FZ4-7](#) [NLVSV1T244MUTBG](#)  
[74AVC1T45GS-Q100H](#) [CLVC16T245MDGGREP](#) [MC10H124FNG](#) [CAVCB164245MDGGREP](#) [CD40109BPWR](#) [MC10H350FNG](#)  
[MC10H125FNG](#) [MC100EPT21MNR4G](#) [MC100EP91DWG](#) [NLSX3018MUTAG](#) [NLSV2T244MUTAG](#) [NLSX3013FCT1G](#)  
[NLSX5011AMX1TCG](#) [PCA9306USG](#) [SN74GTL1655DGGR](#) [SN74AVCA406LZQSR](#) [NLSX4014DTR2G](#) [NLSX3018DTR2G](#)  
[LTC1045CSW#PBF](#) [LTC1045CN#PBF](#) [SY100EL92ZG](#) [74AXP1T34GMH](#) [74AXP1T34GNH](#) [LSF0204DPWR](#) [PI4ULS3V204LE](#)  
[ADG3245BRUZ-REEL7](#) [ADG3123BRUZ](#) [ADG3245BRUZ](#) [ADG3246BCPZ](#) [ADG3308BCPZ-REEL](#) [ADG3233BRJZ-REEL7](#)  
[ADG3233BRMZ](#)