

NX20P3483UK

USB PD and Type-C high voltage sink/source combo switch with protection

Rev. 2 — 4 March 2019

Product short data sheet

1. General description

The NX20P3483UK is a product with combined multiple power switches and an LDO for USB PD application. The device includes a bidirectional high voltage power switch which supports both 20V sink and 6V source; a 5V power switch for source and a 100mA LDO provides power supply for dead battery operation.

The high voltage power switch has 29V DC tolerance, and is able to sink up to 5A at maximum of 20V and source up to 3.4A at maximum of 6V. When it is configured as a high voltage sink switch, the path has overvoltage protection and reverse current protection features. While it is configured as high voltage source switch, the adjustable overcurrent limit circuit is integrated.

The 5V power switch has an adjustable overcurrent limit, “ideal diode” feature and short circuit protection. The maximum current capability is 3.4A. It supports fast role swap for USB PD3.0 application.

A VBUS discharge circuit is integrated according to USB PD VBUS discharging requirement. To minimize inrush current during normal startup, turn on slew rate control has been built in for all power switches. Over temperature protection is also equipped to automatically isolate the switch terminals when the device is overheated.

The device is controlled through an I²C-bus interface, allowing the host to configure switches and program different specified parameters according to an I²C register map.

The NX20P3483UK is offered with WLCSP42 package: 0.4mm pitch, 2.51 x 2.91 x 0.525mm, 0.4mm pitch.

2. Features and benefits

- Wide supply voltage range for VBUS from 2.8V to 20V
- System power supply V5V from 4.0V to 5.5V
- Chip power supply VDD from 2.7V to 5.5V
- VBUS to VCHG Switch
 - ◆ 28mΩ (typical) ultra low ON resistance
 - ◆ I_{SW} maximum 5A continuous current
 - ◆ Bidirectional operation: 20V sink switch from VBUS to VCHG with RCP and 6V source switch from VCHG to VBUS with overcurrent limit
 - ◆ Adjustable overcurrent limit for source configuration from 400mA to 3.4A by I²C-bus interface
- V5V to VBUS switch
 - ◆ 38mΩ (typical) ultra low ON resistance



- ◆ I_{SW} maximum 3.4A continuous current
- ◆ Adjustable overcurrent limit from 400mA to 3.4A by I²C-bus interface
- Integrated high voltage LDO with reverse voltage protection
- Built in slew rate control for all power switches for inrush current limit
- Supports 1MHz Fast Mode Plus I²C-bus interface and four different I²C slave addresses by ADDR pin
- Safety approvals
 - ◆ UL 62368-1, file no. 20181009- E470128
 - ◆ IEC 62368-1, file no. DK-77044-UL
- Protection circuitry
 - ◆ Over-Temperature Protection
 - ◆ Over-Voltage Protection
 - ◆ Under-Voltage Lockout
 - ◆ Reverse current protection
- Surge protection:
 - ◆ IEC61000-4-5 exceeds ± 95 V on VBUS
 - ◆ IEC61000-4-5 exceeds ± 100 V on VBUS with 4.7uF capacitor
- ESD protection
 - ◆ IEC61000-4-2 contact discharge exceeds 8 kV on VBUS
 - ◆ IEC61000-4-2 air discharge exceeds 15kV on VBUS
 - ◆ HBM ANSI/ESDA/JEDEC JS-001 Class 2 exceeds 2 kV on all pins
 - ◆ CDM ANSI/ESDA/JEDEC JS-002 exceeds 500V
- Operating ambient temperature -40°C to $+85^{\circ}\text{C}$

3. Applications

- Notebook, Ultrabook and Desktop
- USB PD DFP, UFP and DRP
- Tablet and Smart phone

4. Ordering information

Table 1. Ordering information

Type number	Package			Version
	Temperature range	Name	Description	
NX20P3483UK	-40 °C to +85 °C	WLCSP42	wafer level chip-scale package; 42 bumps; 2.91 mm x 2.51 mm x 0.525 mm body (backside coating included)	SOT1459-6

4.1 Ordering options

Table 2. Ordering options

Type number	Orderable part number	Package	Packing method	Minimum order quantity	Temperature
NX20P3483UK	NX20P3483UKAZ	WLCSP42	reel dry pack, SMD, 7" Q1 standard product orientation	2000	T _{amb} = -40 °C to +85 °C

5. Marking

Table 3. Marking

Line	Content	Description
1	Pin 1 dot	Pin 1 dot
	3483UK	Product identification
2	XXXX	4 digit lot number before dot
	??	wafer ID
3	Z	wafer fab code (SSMC)
	t	Identification of assembly site (ASE-K)
	D	RoHS indicator (Dark green)
	YWW	Y: Last digits of year code of assembly, WW: week code of assembly
4	CCC-RRR	Die x-y coordinate

6. Functional diagram

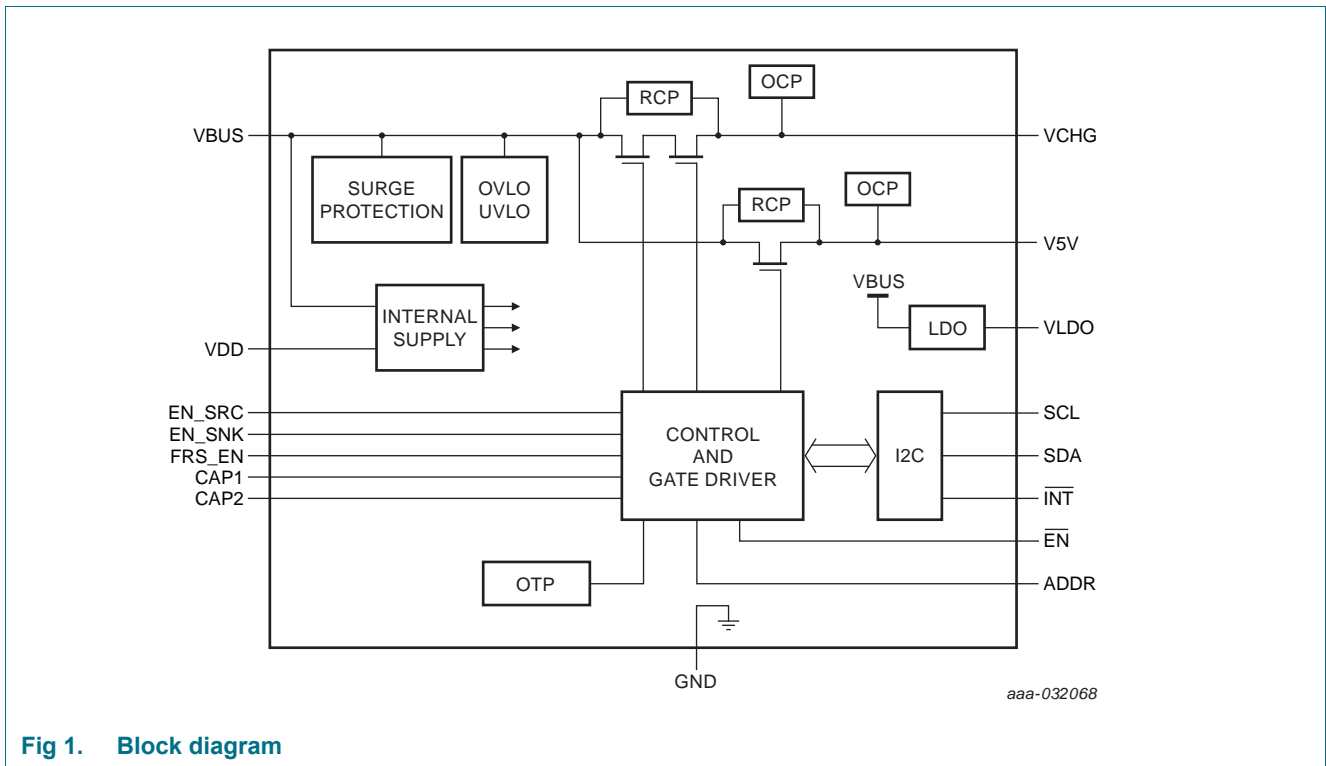
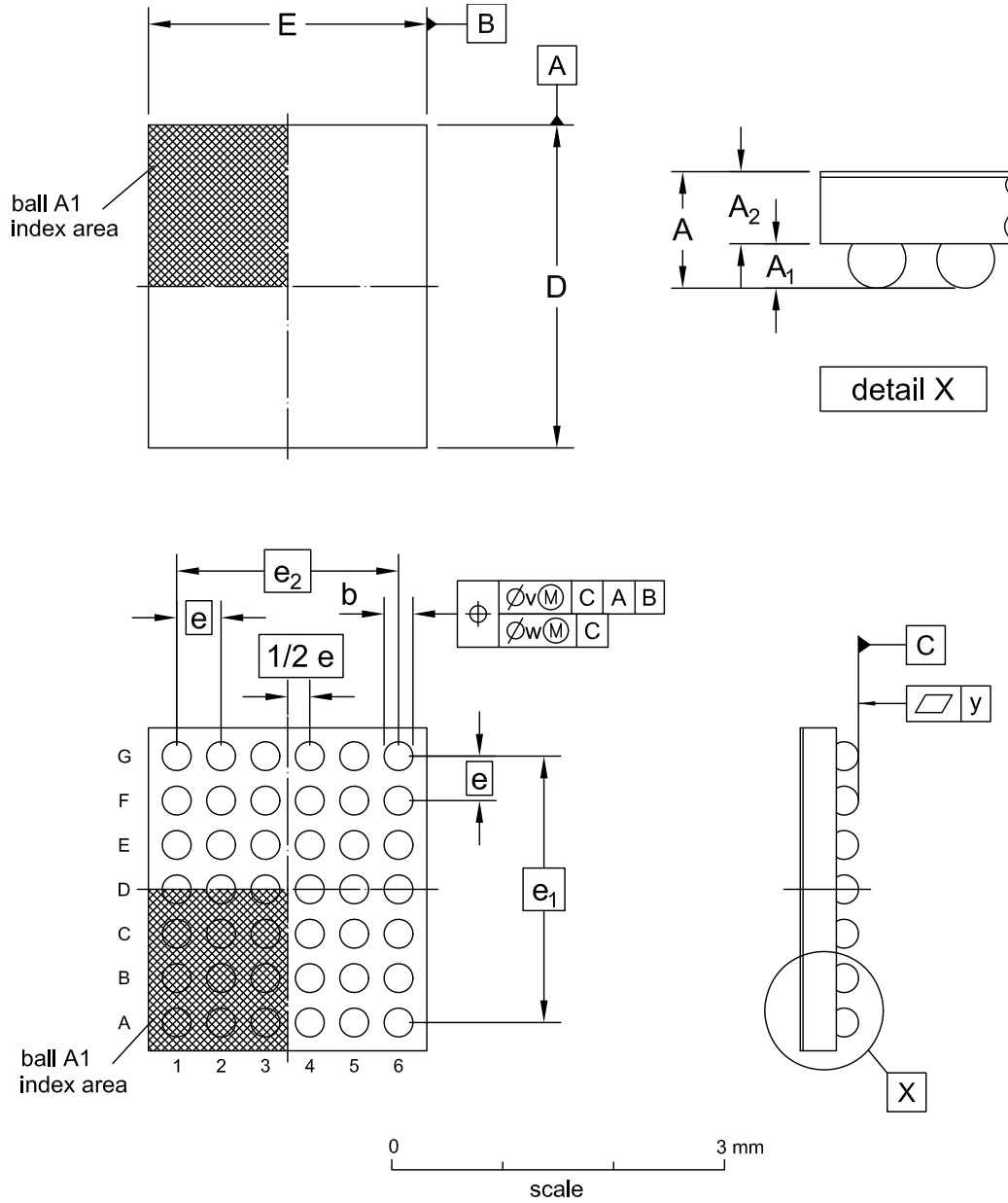

Fig 1. Block diagram

7. Package outline



DIMENSIONS (mm are the original dimensions)

UNIT		A	A ₁	A ₂	b	D	E	e	e ₁	e ₂	v	w	y
mm	MAX.	0.565	0.23	0.350	0.29	2.94	2.54						
	NOM.	0.525	0.20	0.325	0.26	2.91	2.51	0.4	2.4	2.0	0.05	0.02	0.03
	MIN.	0.485	0.17	0.300	0.23	2.88	2.48						

NOTE: Backside coating 25 um

Fig 2. Package outline SOT1459-6 (WLCSP42)

8. Revision history

Table 4. Revision history

Document ID	Release date	Data sheet status	Change notice	Supersedes
NX20P3483UK_SDS v2.0	20190304	Product data sheet	-	NX20P3483UK_SDS v1.0
Modifications:	• Updated Section 2 "Features and benefits"			
NX20P3483UK_SDS v1.0	20181029	Product short data sheet	-	-

9. Legal information

9.1 Data sheet status

Document status ^{[1][2]}	Product status ^[3]	Definition
Objective [short] data sheet	Development	This document contains data from the objective specification for product development.
Preliminary [short] data sheet	Qualification	This document contains data from the preliminary specification.
Product [short] data sheet	Production	This document contains the product specification.

[1] Please consult the most recently issued document before initiating or completing a design.

[2] The term 'short data sheet' is explained in section "Definitions".

[3] The product status of device(s) described in this document may have changed since this document was published and may differ in case of multiple devices. The latest product status information is available on the Internet at URL <http://www.nxp.com>.

9.2 Definitions

Draft — The document is a draft version only. The content is still under internal review and subject to formal approval, which may result in modifications or additions. NXP Semiconductors does not give any representations or warranties as to the accuracy or completeness of information included herein and shall have no liability for the consequences of use of such information.

Short data sheet — A short data sheet is an extract from a full data sheet with the same product type number(s) and title. A short data sheet is intended for quick reference only and should not be relied upon to contain detailed and full information. For detailed and full information see the relevant full data sheet, which is available on request via the local NXP Semiconductors sales office. In case of any inconsistency or conflict with the short data sheet, the full data sheet shall prevail.

Product specification — The information and data provided in a Product data sheet shall define the specification of the product as agreed between NXP Semiconductors and its customer, unless NXP Semiconductors and customer have explicitly agreed otherwise in writing. In no event however, shall an agreement be valid in which the NXP Semiconductors product is deemed to offer functions and qualities beyond those described in the Product data sheet.

9.3 Disclaimers

Limited warranty and liability — Information in this document is believed to be accurate and reliable. However, NXP Semiconductors does not give any representations or warranties, expressed or implied, as to the accuracy or completeness of such information and shall have no liability for the consequences of use of such information. NXP Semiconductors takes no responsibility for the content in this document if provided by an information source outside of NXP Semiconductors.

In no event shall NXP Semiconductors be liable for any indirect, incidental, punitive, special or consequential damages (including - without limitation - lost profits, lost savings, business interruption, costs related to the removal or replacement of any products or rework charges) whether or not such damages are based on tort (including negligence), warranty, breach of contract or any other legal theory.

Notwithstanding any damages that customer might incur for any reason whatsoever, NXP Semiconductors' aggregate and cumulative liability towards customer for the products described herein shall be limited in accordance with the *Terms and conditions of commercial sale* of NXP Semiconductors.

Right to make changes — NXP Semiconductors reserves the right to make changes to information published in this document, including without limitation specifications and product descriptions, at any time and without notice. This document supersedes and replaces all information supplied prior to the publication hereof.

Suitability for use — NXP Semiconductors products are not designed, authorized or warranted to be suitable for use in life support, life-critical or safety-critical systems or equipment, nor in applications where failure or malfunction of an NXP Semiconductors product can reasonably be expected to result in personal injury, death or severe property or environmental damage. NXP Semiconductors and its suppliers accept no liability for inclusion and/or use of NXP Semiconductors products in such equipment or applications and therefore such inclusion and/or use is at the customer's own risk.

Applications — Applications that are described herein for any of these products are for illustrative purposes only. NXP Semiconductors makes no representation or warranty that such applications will be suitable for the specified use without further testing or modification.

Customers are responsible for the design and operation of their applications and products using NXP Semiconductors products, and NXP Semiconductors accepts no liability for any assistance with applications or customer product design. It is customer's sole responsibility to determine whether the NXP Semiconductors product is suitable and fit for the customer's applications and products planned, as well as for the planned application and use of customer's third party customer(s). Customers should provide appropriate design and operating safeguards to minimize the risks associated with their applications and products.

NXP Semiconductors does not accept any liability related to any default, damage, costs or problem which is based on any weakness or default in the customer's applications or products, or the application or use by customer's third party customer(s). Customer is responsible for doing all necessary testing for the customer's applications and products using NXP Semiconductors products in order to avoid a default of the applications and the products or of the application or use by customer's third party customer(s). NXP does not accept any liability in this respect.

Limiting values — Stress above one or more limiting values (as defined in the Absolute Maximum Ratings System of IEC 60134) will cause permanent damage to the device. Limiting values are stress ratings only and (proper) operation of the device at these or any other conditions above those given in the Recommended operating conditions section (if present) or the Characteristics sections of this document is not warranted. Constant or repeated exposure to limiting values will permanently and irreversibly affect the quality and reliability of the device.

Terms and conditions of commercial sale — NXP Semiconductors products are sold subject to the general terms and conditions of commercial sale, as published at <http://www.nxp.com/profile/terms>, unless otherwise agreed in a valid written individual agreement. In case an individual agreement is concluded only the terms and conditions of the respective agreement shall apply. NXP Semiconductors hereby expressly objects to applying the customer's general terms and conditions with regard to the purchase of NXP Semiconductors products by customer.

No offer to sell or license — Nothing in this document may be interpreted or construed as an offer to sell products that is open for acceptance or the grant, conveyance or implication of any license under any copyrights, patents or other industrial or intellectual property rights.

Export control — This document as well as the item(s) described herein may be subject to export control regulations. Export might require a prior authorization from competent authorities.

Non-automotive qualified products — Unless this data sheet expressly states that this specific NXP Semiconductors product is automotive qualified, the product is not suitable for automotive use. It is neither qualified nor tested in accordance with automotive testing or application requirements. NXP Semiconductors accepts no liability for inclusion and/or use of non-automotive qualified products in automotive equipment or applications.

In the event that customer uses the product for design-in and use in automotive applications to automotive specifications and standards, customer (a) shall use the product without NXP Semiconductors' warranty of the product for such automotive applications, use and specifications, and (b) whenever customer uses the product for automotive applications beyond

NXP Semiconductors' specifications such use shall be solely at customer's own risk, and (c) customer fully indemnifies NXP Semiconductors for any liability, damages or failed product claims resulting from customer design and use of the product for automotive applications beyond NXP Semiconductors' standard warranty and NXP Semiconductors' product specifications.

Translations — A non-English (translated) version of a document is for reference only. The English version shall prevail in case of any discrepancy between the translated and English versions.

9.4 Trademarks

Notice: All referenced brands, product names, service names and trademarks are the property of their respective owners.

10. Contact information

For more information, please visit: <http://www.nxp.com>

For sales office addresses, please send an email to: salesaddresses@nxp.com

11. Contents

1	General description	1
2	Features and benefits	1
3	Applications	3
4	Ordering information	3
4.1	Ordering options	3
5	Marking	3
6	Functional diagram	4
7	Package outline	5
8	Revision history	6
9	Legal information	7
9.1	Data sheet status	7
9.2	Definitions	7
9.3	Disclaimers	7
9.4	Trademarks	8
10	Contact information	8
11	Contents	9

Please be aware that important notices concerning this document and the product(s) described herein, have been included in section 'Legal information'.

© NXP B.V. 2019.

All rights reserved.

For more information, please visit: <http://www.nxp.com>

For sales office addresses, please send an email to: salesaddresses@nxp.com

Date of release: 4 March 2019

Document identifier: NX20P3483UK_SDS

X-ON Electronics

Largest Supplier of Electrical and Electronic Components

Click to view similar products for [USB Interface IC](#) category:

Click to view products by [NXP](#) manufacturer:

Other Similar products are found below :

[CY7C69356-48LTXC](#) [USB3319C-GJ-TR](#) [USB3370B-EZK-TR](#) [CYPD2120-24LQXI](#) [CYPD2122-20FNXIT](#) [CYPD2122-24LQXIT](#) [LIF-UC120-SWG36ITR50](#) [UPD360-A/6HX](#) [CP2102NP1174GM](#) [CG8454AM](#) [DPO2039DABQ-13](#) [CY7C68034-56LTXC](#) [TUSB213IRGYT](#) [TUSB213RGYT](#) [USB3503T-I/ML](#) [CY7C63310-SXC](#) [CY7C68013A-56LTXIT](#) [USB3316C-CP-TR](#) [USB3250-ABZJ](#) [FT220XS-R](#) [MAX3107ETG+](#) [MAX14632EZK+T](#) [USB3300-EZK](#) [LAN9514-JZX](#) [CYPD2120-24LQXIT](#) [MAX3100CEE+T](#) [USB5826-I/KD](#) [USB5826/KD](#) [USB5906/KD](#) [USB5916/KD](#) [USB5926/KD](#) [TUSB215QRGYTQ1](#) [TUSB522PRGER](#) [NB7NPQ701MMTTBG](#) [TUSB213RGYR](#) [USB5926-I/KD](#) [USB5906-I/KD](#) [USB4640I-HZH-03](#) [CY7C63813-SXC](#) [CY7C63823-SXC](#) [CY7C64215-28PVXC](#) [CY7C68013A-128AXC](#) [CY7C68013A-56LTXI](#) [CY7C68013A-56PVXC](#) [CY7C68013A-56PVXI](#) [CYPD1120-40LQXI](#) [AP43771VDKZ-13](#) [AP43771VFBZ-13](#) [DIO32320MP10](#) [HT42B534-2](#)