

NX3L1G3157

Low-ohmic single-pole double-throw analog switch

Rev. 10.1 — 24 November 2020

Product data sheet

1 General description

The NX3L1G3157 is a low-ohmic single-pole double-throw analog switch suitable for use as an analog or digital 2:1 multiplexer/demultiplexer. It has a digital select input (S), two independent inputs/outputs (Y0 and Y1) and a common input/output (Z). Schmitt trigger action at the digital input makes the circuit tolerant to slower input rise and fall times.

The NX3L1G3157 allows signals with amplitude up to V_{CC} to be transmitted from Z to Y0 or Y1; or from Y0 or Y1 to Z. Its low ON resistance (0.5 Ω) and flatness (0.13 Ω) ensures minimal attenuation and distortion of transmitted signals.

2 Features and benefits

- Wide supply voltage range from 1.4 V to 4.3 V
- Very low ON resistance:
 - 1.6 Ω (typical) at $V_{CC} = 1.4$ V
 - 1.0 Ω (typical) at $V_{CC} = 1.65$ V
 - 0.55 Ω (typical) at $V_{CC} = 2.3$ V
 - 0.50 Ω (typical) at $V_{CC} = 2.7$ V
 - 0.50 Ω (typical) at $V_{CC} = 4.3$ V
- Break-before-make switching
- High noise immunity
- ESD protection:
 - HBM JESD22-A114F Class 3A exceeds 7500 V
 - MM JESD22-A115-A exceeds 200 V
 - CDM AEC-Q100-011 revision B exceeds 1000 V
 - IEC61000-4-2 contact discharge exceeds 8000 V for switch ports
- CMOS low-power consumption
- Latch-up performance exceeds 100 mA per JESD78 Class II Level A
- Direct interface with TTL levels at 3.0 V
- Control input accepts voltages above supply voltage
- High current handling capability (350 mA continuous current under 3.3 V supply)
- Specified from -40 °C to +85 °C and from -40 °C to +125 °C

3 Applications

- Cell phone
- PDA
- Portable media player



4 Ordering information

Table 1. Ordering information

Type number	Topside marking ^[1]	Package		
		Name	Description	Version
NX3L1G3157GM	MJ	XSON6	plastic extremely thin small outline package; no leads; 6 terminals; body 1 x 1.45 x 0.5 mm	SOT886

[1] The pin 1 indicator is located on the lower left corner of the device, below the marking code.

4.1 Ordering options

Table 2. Ordering options

Type number	Orderable part number	Package	Packing method	Minimum order quantity	Temperature
NX3L1G3157GM	NX3L1G3157GM,115 ^[1]	XSON6	REEL 7" Q1 NDP	5000	T _{amb} = -40 °C to +125 °C
NX3L1G3157GM	NX3L1G3157GMZ	XSON6	REEL 7" Q1 NDP SSB ^[2]	5000	T _{amb} = -40 °C to +125 °C

[1] Will go EOL - migrate to new leadframe NX3L1G3157GMZ orderable part number

[2] This packing method uses a Static Shielding Bag (SSB) solution. Material is to be kept in the sealed bag between uses.

5 Functional diagram

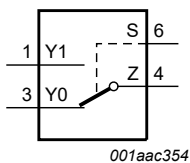

Figure 1. Logic symbol

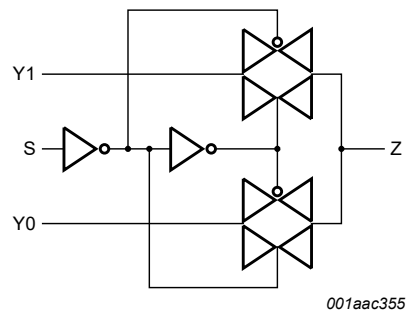

Figure 2. Logic diagram

6 Pinning information

6.1 Pinning

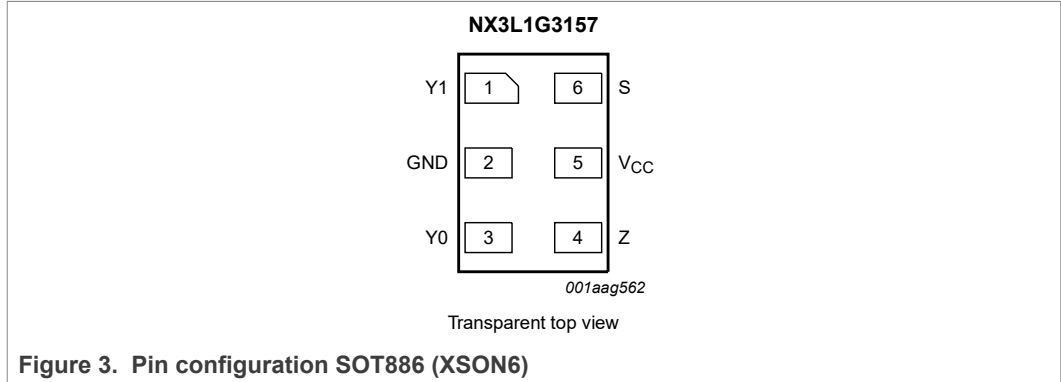

Figure 3. Pin configuration SOT886 (XSON6)

6.2 Pin description

Table 3. Pin description

Symbol	Pin	Description
Y1	1	independent input or output
GND	2	ground (0 V)
Y0	3	independent input or output
Z	4	common output or input
V _{CC}	5	supply voltage
S	6	select input

7 Functional description

Table 4. Function table^[1]

Input S	Channel on
L	Y0
H	Y1

[1] H = HIGH voltage level; L = LOW voltage level.

8 Limiting values

Table 5. Limiting values

In accordance with the Absolute Maximum Rating System (IEC 60134). Voltages are referenced to GND (ground = 0 V).

Symbol	Parameter	Conditions	Min	Max	Unit
V _{CC}	supply voltage		-0.5	+4.6	V
V _I	input voltage	select input S	^[1] -0.5	+4.6	V
V _{SW}	switch voltage		^[2] -0.5	V _{CC} + 0.5	V
I _{IK}	input clamping current	V _I < -0.5 V	-50	-	mA
I _{SK}	switch clamping current	V _I < -0.5 V or V _I > V _{CC} + 0.5 V	-	±50	mA

Table 5. Limiting values...continued

In accordance with the Absolute Maximum Rating System (IEC 60134). Voltages are referenced to GND (ground = 0 V).

Symbol	Parameter	Conditions	Min	Max	Unit
I _{SW}	switch current	V _{SW} > -0.5 V or V _{SW} < V _{CC} + 0.5 V; source or sink current	-	±350	mA
		V _{SW} > -0.5 V or V _{SW} < V _{CC} + 0.5 V; pulsed at 1 ms duration, < 10 % duty cycle; peak current	-	±500	mA
T _{stg}	storage temperature		-65	+150	°C
P _{tot}	total power dissipation	T _{amb} = -40 °C to +125 °C	[3] -	250	mW

[1] The minimum input voltage rating may be exceeded if the input current rating is observed.

[2] The minimum and maximum switch voltage ratings may be exceeded if the switch clamping current rating is observed but may not exceed 4.6 V.

[3] For XSON6 package: above 118 °C the value of P_{tot} derates linearly with 7.8 mW/K.

9 Recommended operating conditions

Table 6. Recommended operating conditions

Symbol	Parameter	Conditions	Min	Max	Unit
V _{CC}	supply voltage		1.4	4.3	V
V _I	input voltage	select input S	0	4.3	V
V _{SW}	switch voltage		[1] 0	V _{CC}	V
T _{amb}	ambient temperature		-40	+125	°C
Δt/ΔV	input transition rise and fall rate	V _{CC} = 1.4 V to 4.3 V	[2] -	200	ns/V

[1] To avoid sinking GND current from terminal Z when switch current flows in terminal Yn, the voltage drop across the bidirectional switch must not exceed 0.4 V. If the switch current flows into terminal Z, no GND current flows from terminal Yn. In this case, there is no limit for the voltage drop across the switch.

[2] Applies to control signal levels.

10 Static characteristics

Table 7. Static characteristics

At recommended operating conditions; voltages are referenced to GND (ground 0 V).

Symbol	Parameter	Conditions	T _{amb} = 25 °C			T _{amb} = -40 °C to +125 °C			Unit
			Min	Typ	Max	Min	Max (85 °C)	Max (125 °C)	
V _{IH}	HIGH-level input voltage	V _{CC} = 1.4 V to 1.95 V	0.65V _{CC}	-	-	0.65V _{CC}	-	-	V
		V _{CC} = 2.3 V to 2.7 V	1.7	-	-	1.7	-	-	V
		V _{CC} = 2.7 V to 3.6 V	2.0	-	-	2.0	-	-	V
		V _{CC} = 3.6 V to 4.3 V	0.7V _{CC}	-	-	0.7V _{CC}	-	-	V
V _{IL}	LOW-level input voltage	V _{CC} = 1.4 V to 1.95 V	-	-	0.35V _{CC}	-	0.35V _{CC}	0.35V _{CC}	V
		V _{CC} = 2.3 V to 2.7 V	-	-	0.7	-	0.7	0.7	V
		V _{CC} = 2.7 V to 3.6 V	-	-	0.8	-	0.8	0.8	V
		V _{CC} = 3.6 V to 4.3 V	-	-	0.3V _{CC}	-	0.3V _{CC}	0.3V _{CC}	V
I _I	input leakage current	select input S; V _I = GND to 4.3 V; V _{CC} = 1.4 V to 4.3 V	-	-	-	-	±0.5	±1	μA

Table 7. Static characteristics...continued

At recommended operating conditions; voltages are referenced to GND (ground 0 V).

Symbol	Parameter	Conditions	T _{amb} = 25 °C			T _{amb} = -40 °C to +125 °C			Unit
			Min	Typ	Max	Min	Max (85 °C)	Max (125 °C)	
I _{S(OFF)}	OFF-state leakage current	Y0 and Y1 port; see Figure 4							
		V _{CC} = 1.4 V to 3.6 V	-	-	±5	-	±50	±500	nA
		V _{CC} = 3.6 V to 4.3 V	-	-	±10	-	±50	±500	nA
I _{S(ON)}	ON-state leakage current	Z port; see Figure 5							
		V _{CC} = 1.4 V to 3.6 V	-	-	±5	-	±50	±500	nA
		V _{CC} = 3.6 V to 4.3 V	-	-	±10	-	±50	±500	nA
I _{CC}	supply current	V _I = V _{CC} or GND; V _{SW} = GND or V _{CC}							
		V _{CC} = 3.6 V	-	-	100	-	690	6000	nA
		V _{CC} = 4.3 V	-	-	150	-	800	7000	nA
C _I	input capacitance		-	1.0	-	-	-	-	pF
C _{S(OFF)}	OFF-state capacitance		-	35	-	-	-	-	pF
C _{S(ON)}	ON-state capacitance		-	130	-	-	-	-	pF

10.1 Test circuits

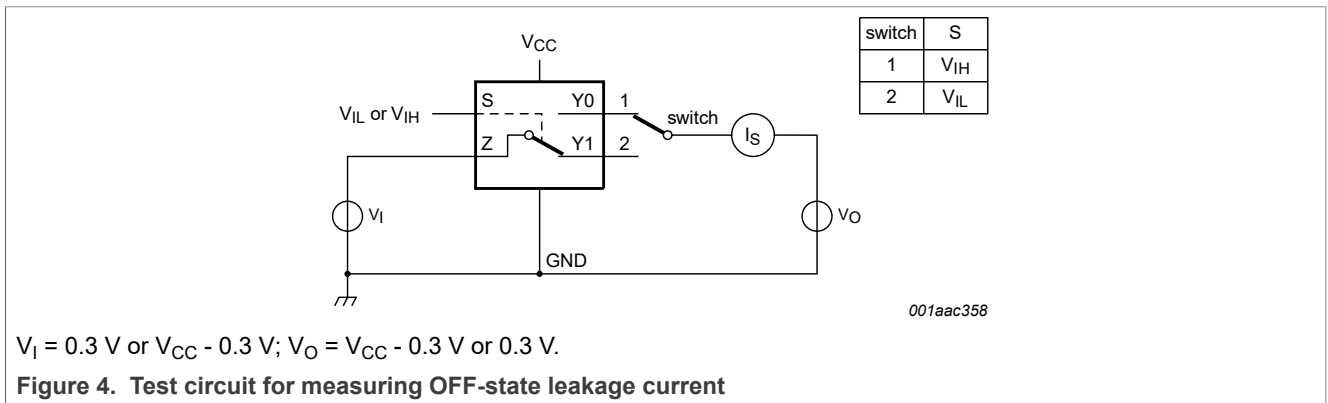

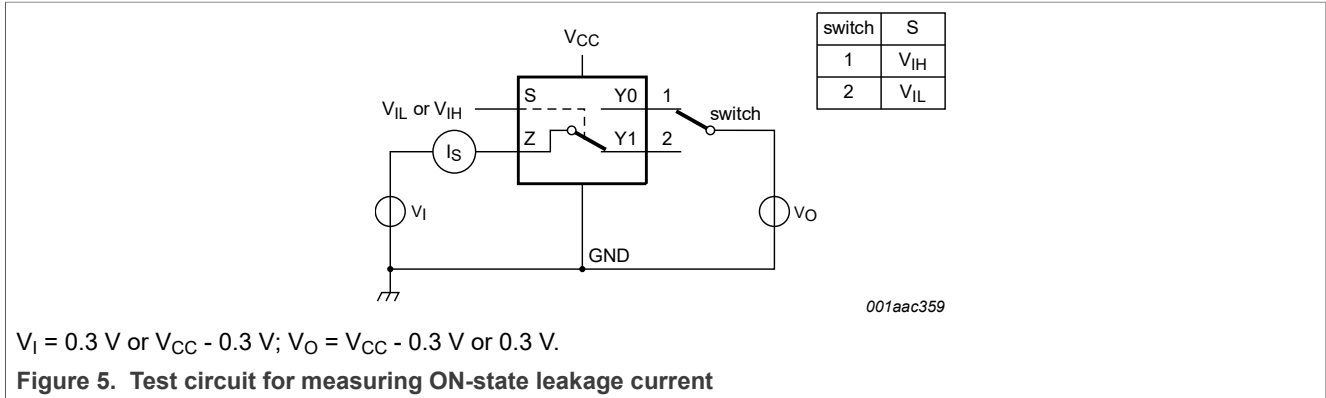

10.2 ON resistance

Table 8. ON resistance

At recommended operating conditions; voltages are referenced to GND (ground = 0 V); for graphs see Figure 7 to Figure 13.

Symbol	Parameter	Conditions	T _{amb} = -40 °C to +85 °C			T _{amb} = -40 °C to +125 °C		Unit
			Min	Typ ^[1]	Max	Min	Max	
R _{ON(peak)}	ON resistance (peak)	V _I = GND to V _{CC} ; I _{SW} = 100 mA; see Figure 6						
		V _{CC} = 1.4 V	-	1.6	3.7	-	4.1	Ω
		V _{CC} = 1.65 V	-	1.0	1.6	-	1.7	Ω
		V _{CC} = 2.3 V	-	0.55	0.8	-	0.9	Ω
		V _{CC} = 2.7 V	-	0.5	0.75	-	0.9	Ω
		V _{CC} = 4.3 V	-	0.5	0.75	-	0.9	Ω
ΔR _{ON}	ON resistance mismatch between channels	V _I = GND to V _{CC} ; I _{SW} = 100 mA	[2]					
		V _{CC} = 1.4 V	-	0.04	0.3	-	0.3	Ω
		V _{CC} = 1.65 V	-	0.04	0.2	-	0.3	Ω
		V _{CC} = 2.3 V	-	0.02	0.08	-	0.1	Ω
		V _{CC} = 2.7 V	-	0.02	0.075	-	0.1	Ω
		V _{CC} = 4.3 V	-	0.02	0.075	-	0.1	Ω
R _{ON(flat)}	ON resistance (flatness)	V _I = GND to V _{CC} ; I _{SW} = 100 mA	[3]					
		V _{CC} = 1.4 V	-	1.0	3.3	-	3.6	Ω
		V _{CC} = 1.65 V	-	0.5	1.2	-	1.3	Ω
		V _{CC} = 2.3 V	-	0.15	0.3	-	0.35	Ω
		V _{CC} = 2.7 V	-	0.13	0.3	-	0.35	Ω
		V _{CC} = 4.3 V	-	0.2	0.4	-	0.45	Ω

[1] Typical values are measured at T_{amb} = 25 °C.

[2] Measured at identical V_{CC}, temperature and input voltage.

[3] Flatness is defined as the difference between the maximum and minimum value of ON resistance measured at identical V_{CC} and temperature.

10.3 ON resistance test circuit and graphs

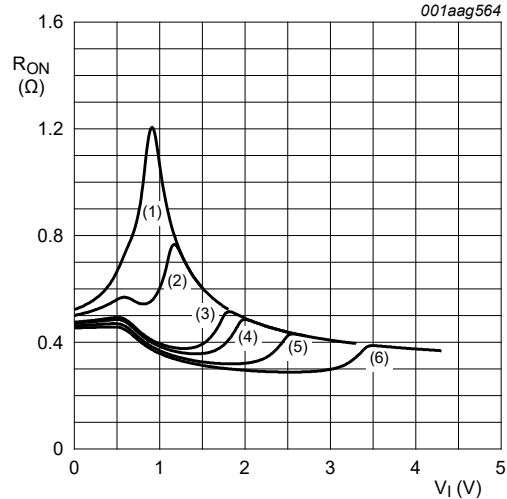
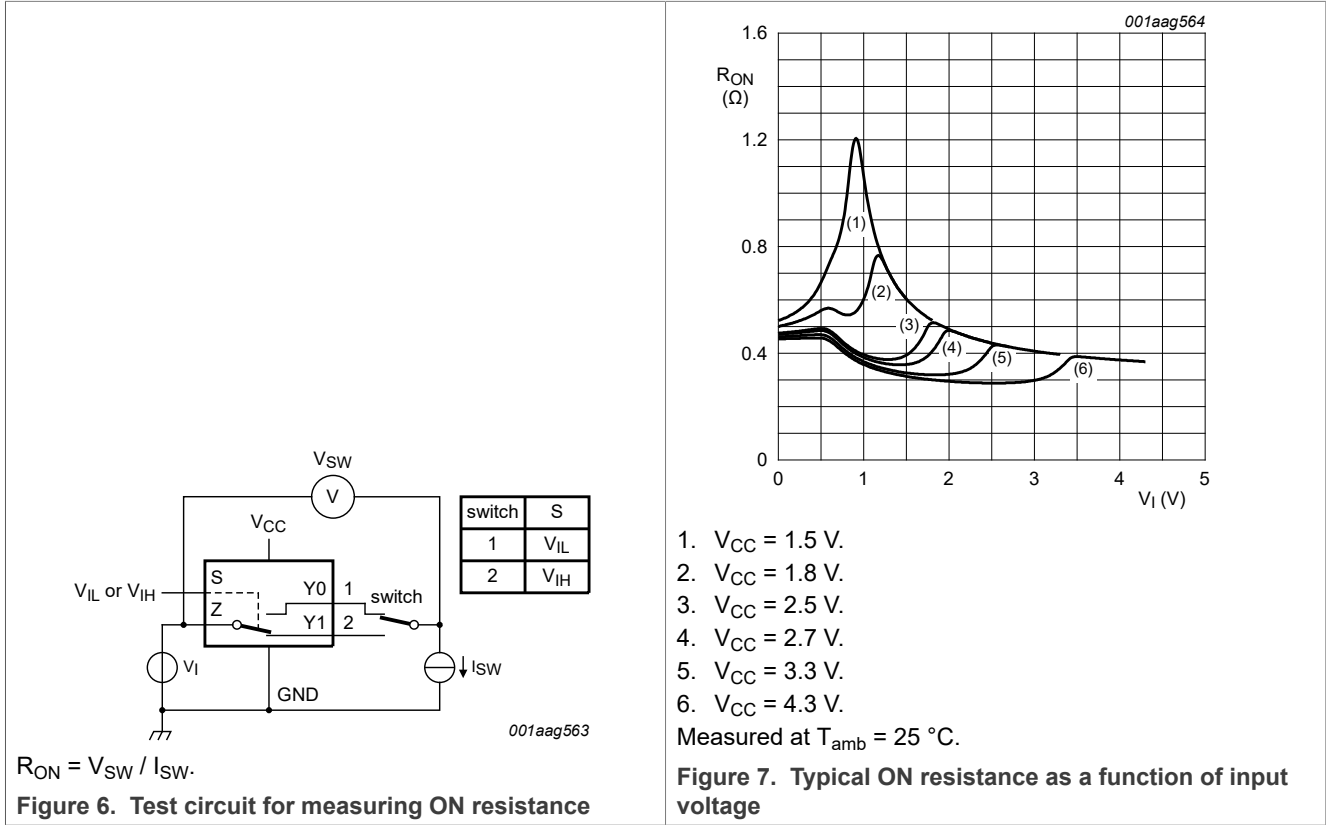

1. V_{CC} = 1.5 V.
 2. V_{CC} = 1.8 V.
 3. V_{CC} = 2.5 V.
 4. V_{CC} = 2.7 V.
 5. V_{CC} = 3.3 V.
 6. V_{CC} = 4.3 V.
- Measured at T_{amb} = 25 °C.

Figure 7. Typical ON resistance as a function of input voltage

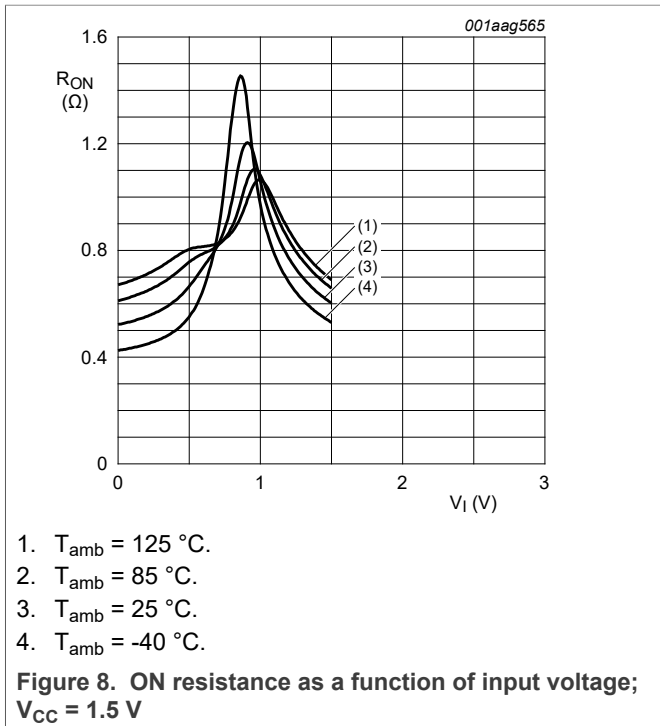

1. T_{amb} = 125 °C.
2. T_{amb} = 85 °C.
3. T_{amb} = 25 °C.
4. T_{amb} = -40 °C.

Figure 8. ON resistance as a function of input voltage; V_{CC} = 1.5 V

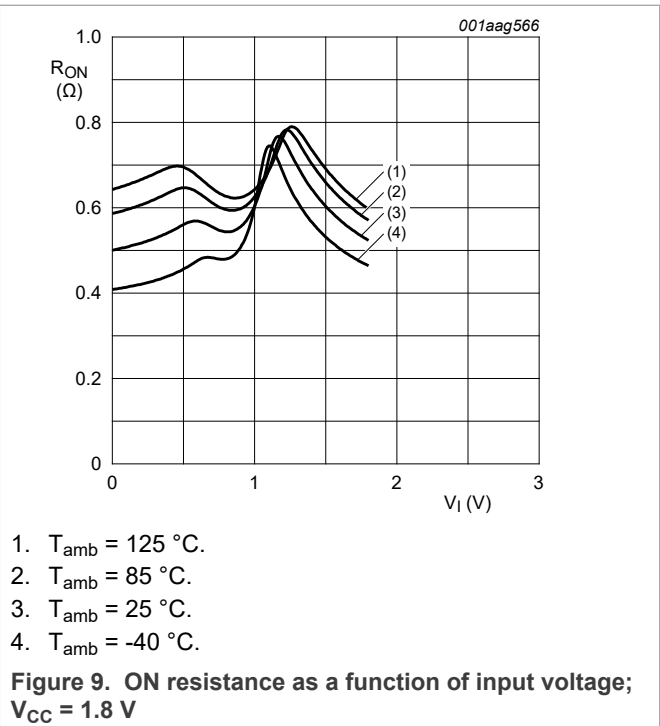

1. T_{amb} = 125 °C.
2. T_{amb} = 85 °C.
3. T_{amb} = 25 °C.
4. T_{amb} = -40 °C.

Figure 9. ON resistance as a function of input voltage; V_{CC} = 1.8 V

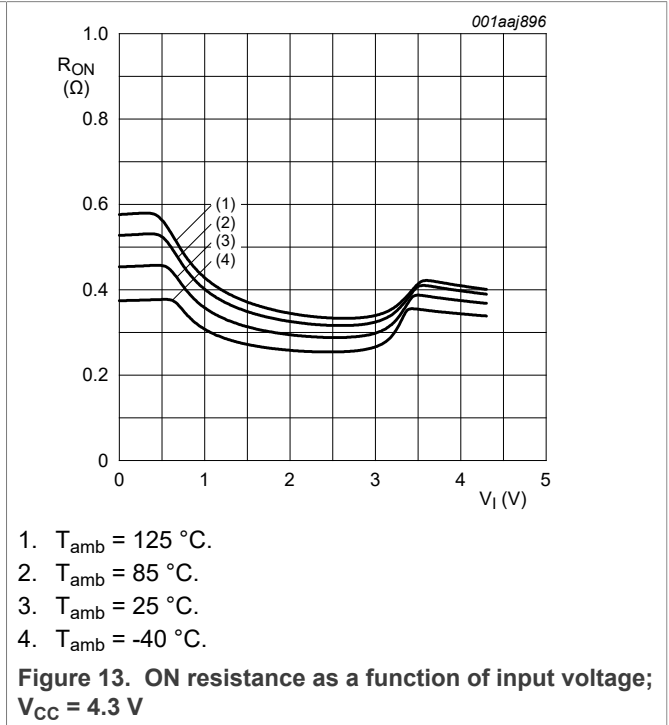
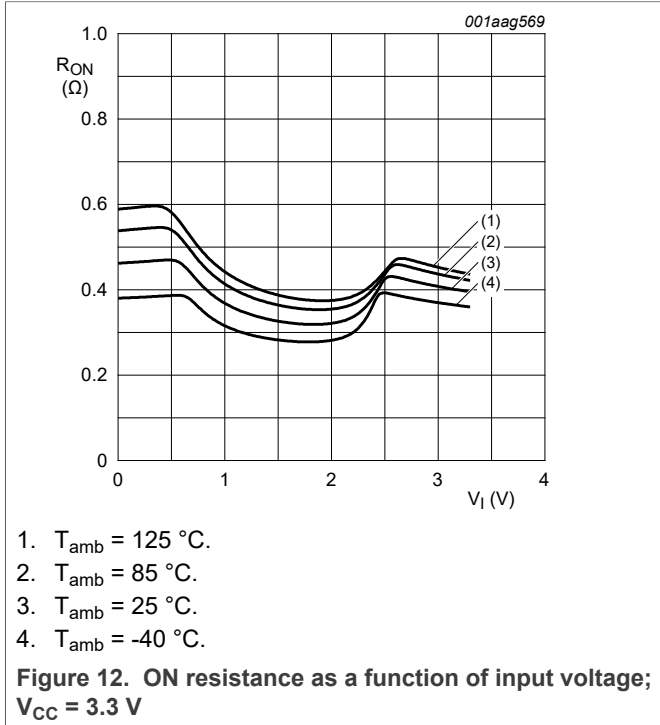
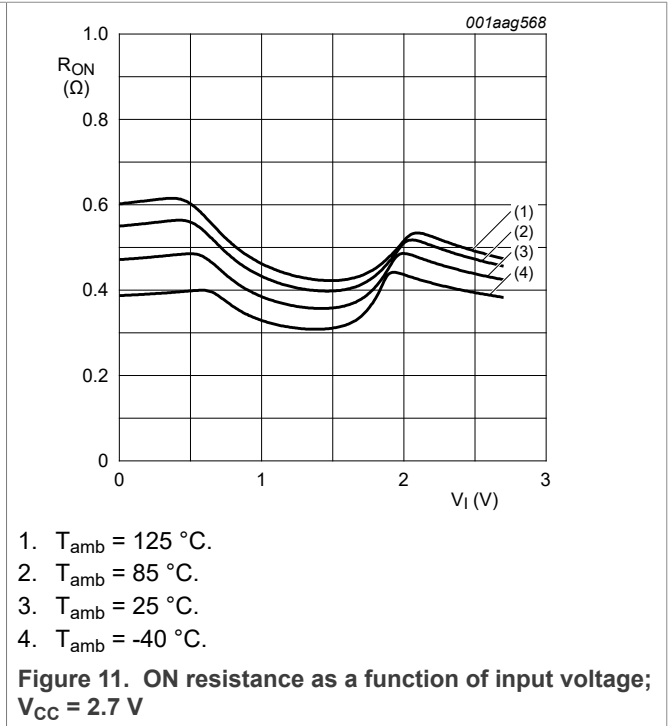
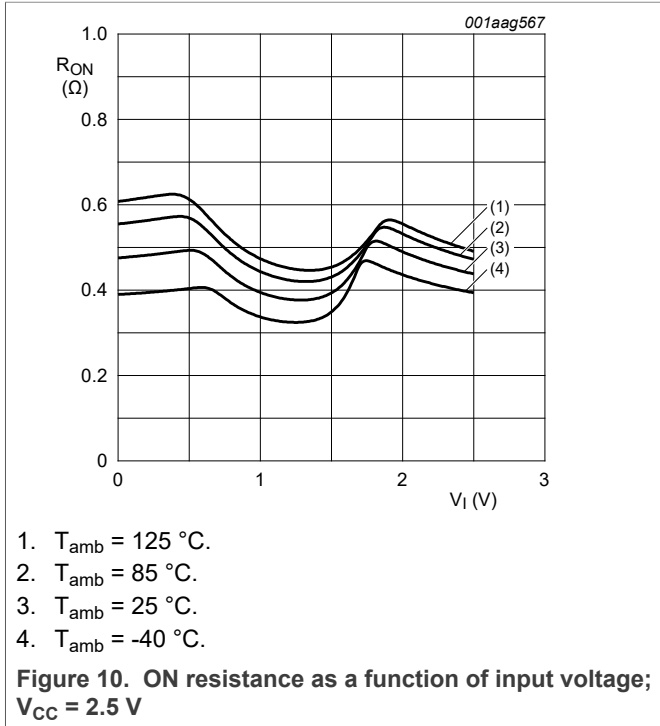

11 Dynamic characteristics

Table 9. Dynamic characteristics

At recommended operating conditions; voltages are referenced to GND (ground = 0 V); for load circuit see [Figure 16](#).

Symbol	Parameter	Conditions	T _{amb} = 25 °C			T _{amb} = -40 °C to +125 °C			Unit
			Min	Typ ^[1]	Max	Min	Max (85 °C)	Max (125 °C)	
t _{en}	enable time	S to Z or Yn; see Figure 14							
		V _{CC} = 1.4 V to 1.6 V	-	28	43	-	48	52	ns
		V _{CC} = 1.65 V to 1.95 V	-	23	35	-	38	42	ns
		V _{CC} = 2.3 V to 2.7 V	-	17	27	-	29	32	ns
		V _{CC} = 2.7 V to 3.6 V	-	14	25	-	27	30	ns
		V _{CC} = 3.6 V to 4.3 V	-	14	25	-	27	30	ns
t _{dis}	disable time	S to Z or Yn; see Figure 14							
		V _{CC} = 1.4 V to 1.6 V	-	9	20	-	25	30	ns
		V _{CC} = 1.65 V to 1.95 V	-	6	15	-	20	23	ns
		V _{CC} = 2.3 V to 2.7 V	-	5	11	-	14	16	ns
		V _{CC} = 2.7 V to 3.6 V	-	4	10	-	12	14	ns
		V _{CC} = 3.6 V to 4.3 V	-	4	10	-	12	14	ns
t _{b-m}	break-before-make time	see Figure 15							
		V _{CC} = 1.4 V to 1.6 V							
		V _{CC} = 1.65 V to 1.95 V							
		V _{CC} = 2.3 V to 2.7 V							
		V _{CC} = 2.7 V to 3.6 V							
		V _{CC} = 3.6 V to 4.3 V							

[1] Typical values are measured at T_{amb} = 25 °C and V_{CC} = 1.5 V, 1.8 V, 2.5 V, 3.3 V and 4.3 V respectively.

[2] Break-before-make guaranteed by design.

11.1 Waveform and test circuits

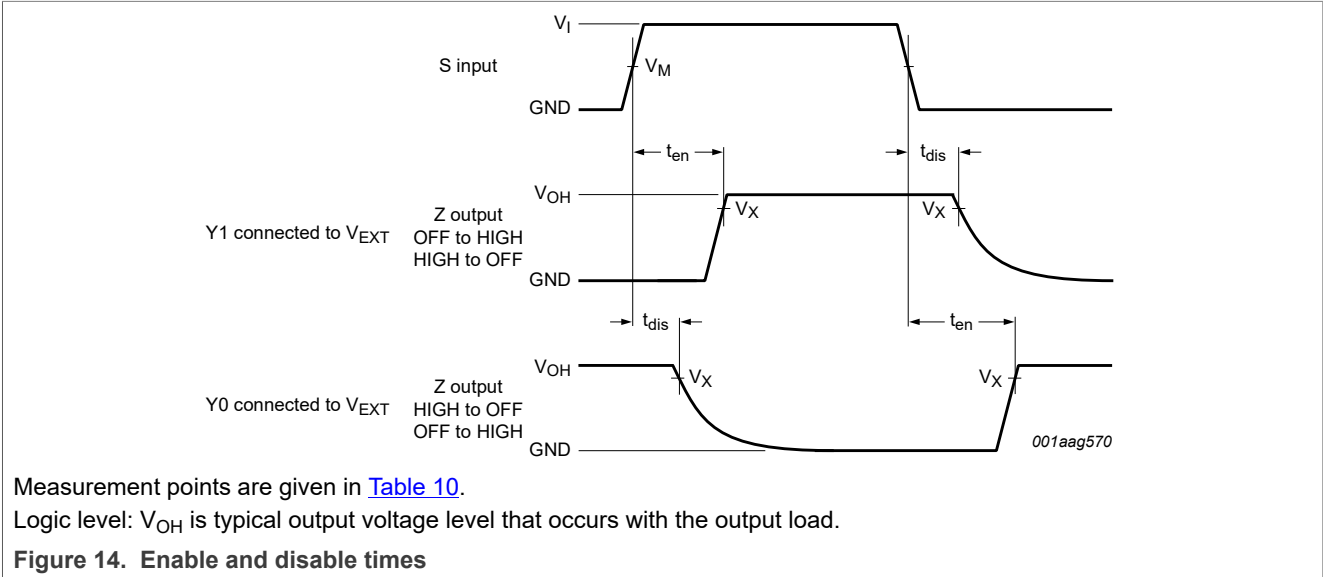

Table 10. Measurement points

Supply voltage	Input	Output
V_{CC}	V_M	V_X
1.4 V to 4.3 V	$0.5V_{CC}$	$0.9V_{OH}$

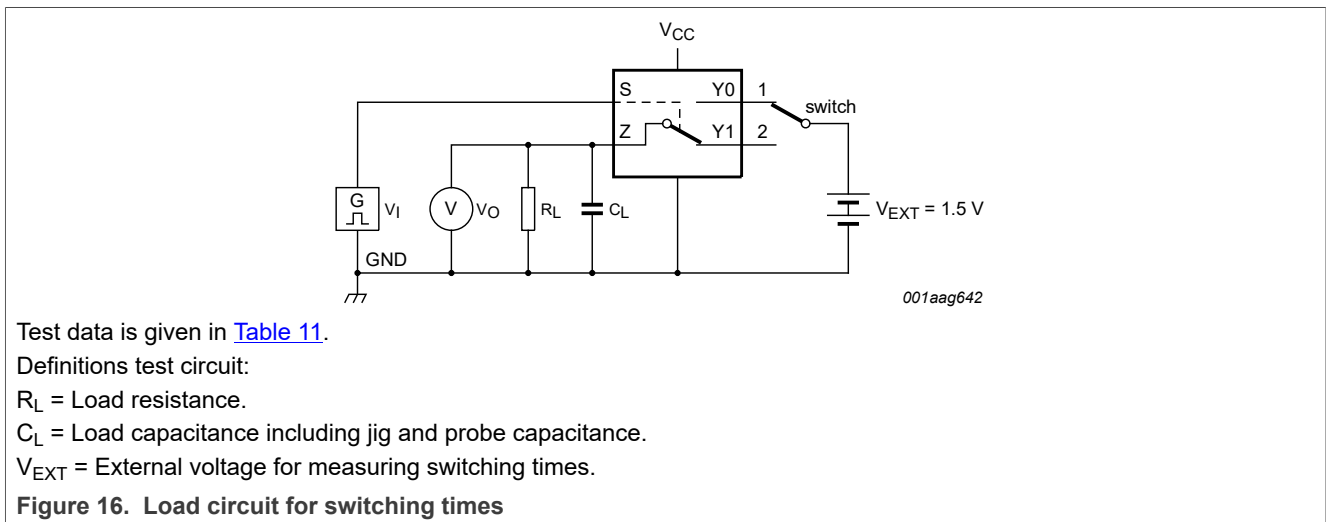
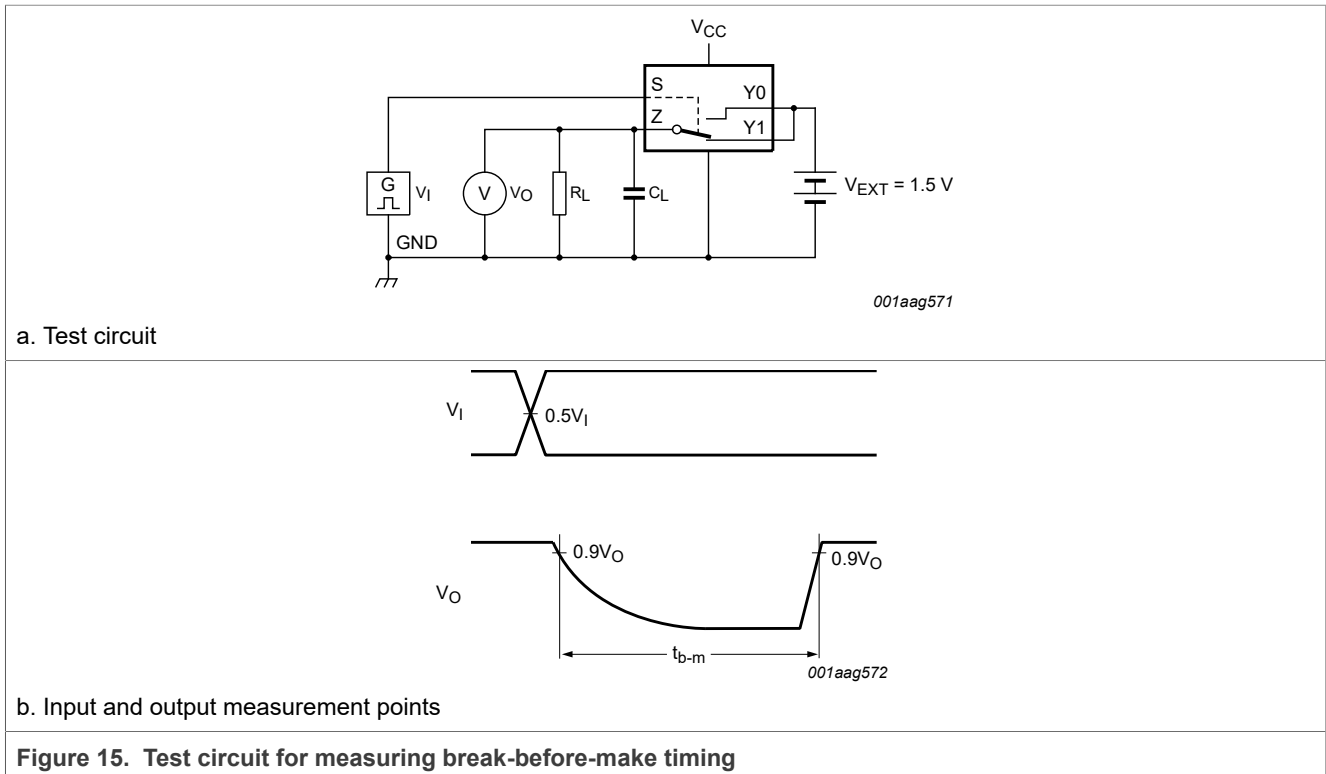

Table 11. Test data

Supply voltage	Input		Load	
V_{CC}	V_I	t_r, t_f	C_L	R_L
1.4 V to 4.3 V	V_{CC}	≤ 2.5 ns	35 pF	50 Ω

11.2 Additional dynamic characteristics

Table 12. Additional dynamic characteristics

At recommended operating conditions; voltages are referenced to GND (ground = 0 V); $V_I = \text{GND or } V_{CC}$ (unless otherwise specified); $t_r = t_f \leq 2.5 \text{ ns}$; $T_{amb} = 25 \text{ }^\circ\text{C}$.

Symbol	Parameter	Conditions	Min	Typ	Max	Unit	
THD	total harmonic distortion	$f_i = 20 \text{ Hz to } 20 \text{ kHz}$; $R_L = 32 \text{ } \Omega$; see Figure 17	[1]				
		$V_{CC} = 1.4 \text{ V}$; $V_I = 1 \text{ V (p-p)}$		-	0.15	-	%
		$V_{CC} = 1.65 \text{ V}$; $V_I = 1.2 \text{ V (p-p)}$		-	0.10	-	%
		$V_{CC} = 2.3 \text{ V}$; $V_I = 1.5 \text{ V (p-p)}$		-	0.02	-	%
		$V_{CC} = 2.7 \text{ V}$; $V_I = 2 \text{ V (p-p)}$		-	0.02	-	%
		$V_{CC} = 4.3 \text{ V}$; $V_I = 2 \text{ V (p-p)}$		-	0.02	-	%
$f_{(-3\text{dB})}$	-3 dB frequency response	$R_L = 50 \text{ } \Omega$; see Figure 18	[1]				
		$V_{CC} = 1.4 \text{ V to } 4.3 \text{ V}$		-	60	-	MHz
α_{iso}	isolation (OFF-state)	$f_i = 100 \text{ kHz}$; $R_L = 50 \text{ } \Omega$; see Figure 19	[1]				
		$V_{CC} = 1.4 \text{ V to } 4.3 \text{ V}$		-	-90	-	dB
V_{ct}	crosstalk voltage	between digital inputs and switch; $f_i = 1 \text{ MHz}$; $C_L = 50 \text{ pF}$; $R_L = 50 \text{ } \Omega$; see Figure 20					
		$V_{CC} = 1.4 \text{ V to } 3.6 \text{ V}$		-	0.2	-	V
		$V_{CC} = 3.6 \text{ V to } 4.3 \text{ V}$		-	0.3	-	V
Q_{inj}	charge injection	$f_i = 1 \text{ MHz}$; $C_L = 0.1 \text{ nF}$; $R_L = 1 \text{ M}\Omega$; $V_{\text{gen}} = 0 \text{ V}$; $R_{\text{gen}} = 0 \text{ } \Omega$; see Figure 21					
		$V_{CC} = 1.5 \text{ V}$		-	3	-	pC
		$V_{CC} = 1.8 \text{ V}$		-	4	-	pC
		$V_{CC} = 2.5 \text{ V}$		-	6	-	pC
		$V_{CC} = 3.3 \text{ V}$		-	9	-	pC
		$V_{CC} = 4.3 \text{ V}$		-	15	-	pC

[1] f_i is biased at $0.5V_{CC}$.

11.3 Test circuits

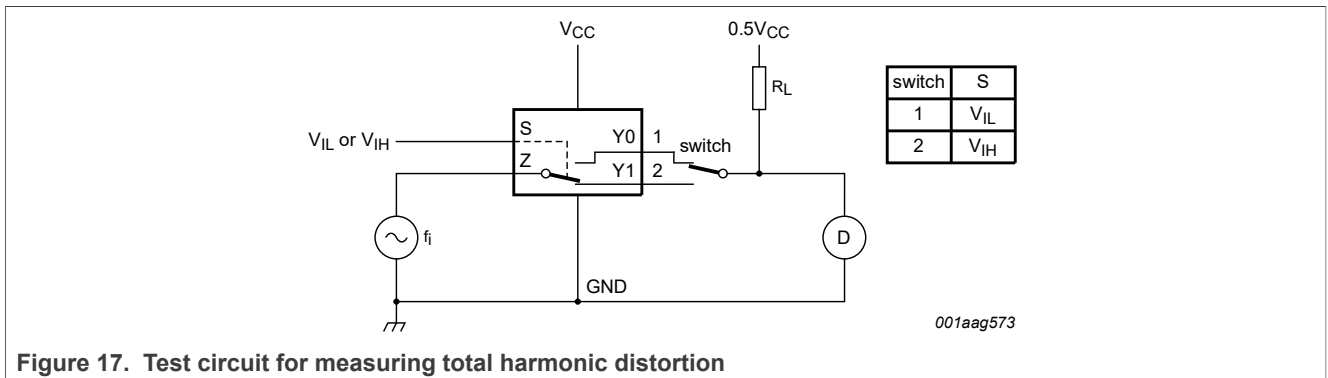
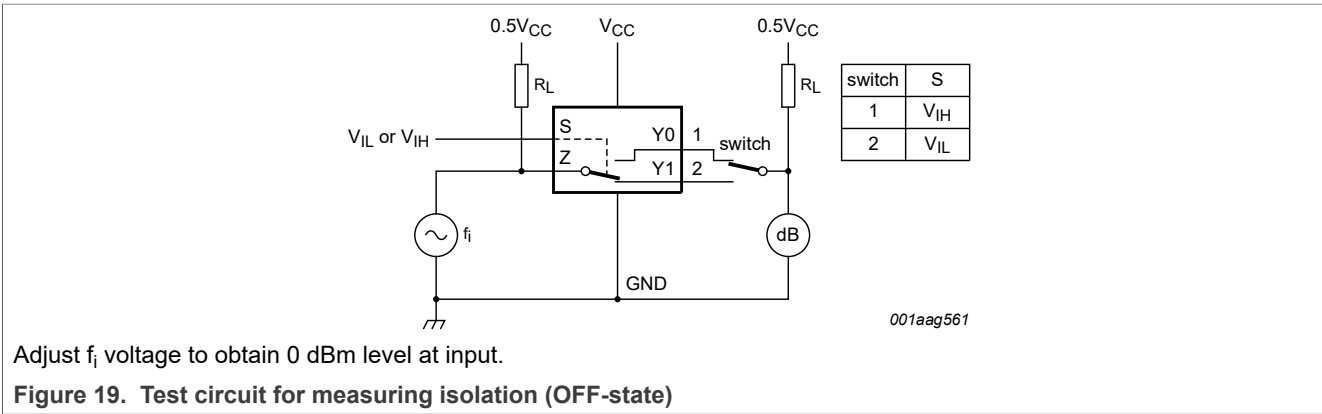
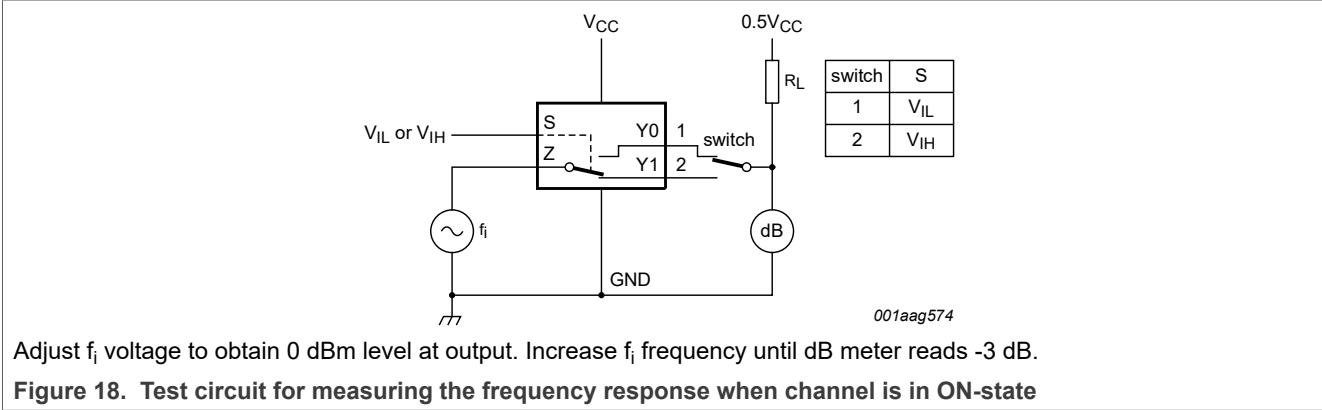
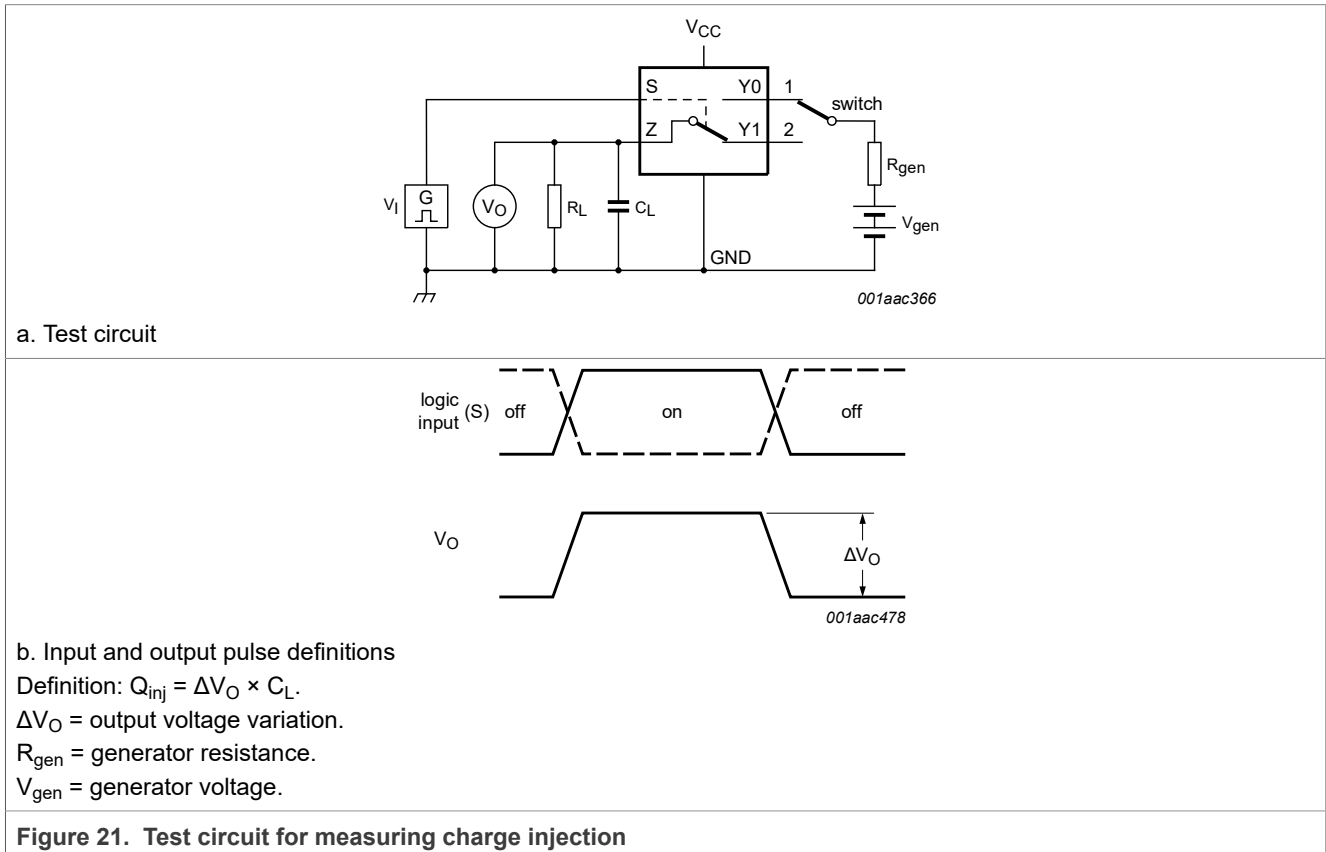
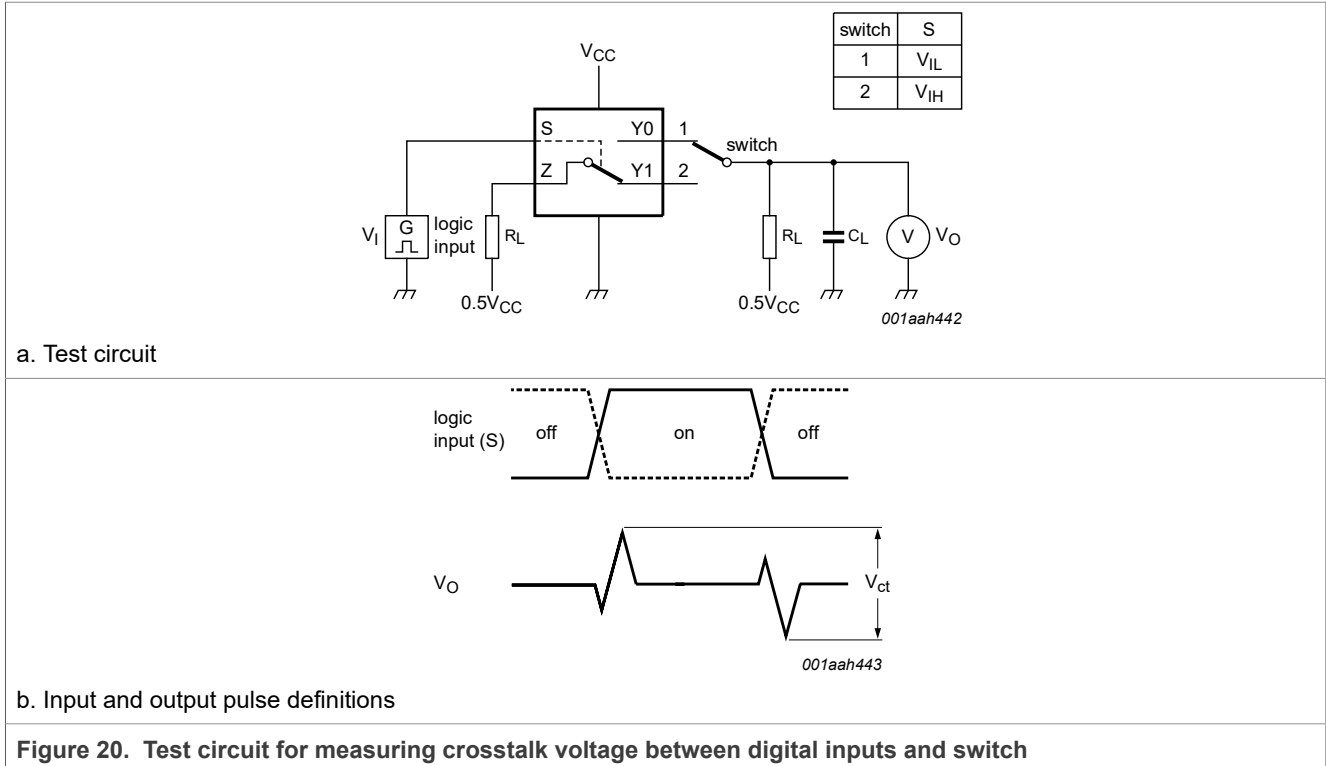

Figure 17. Test circuit for measuring total harmonic distortion





12 Package outline

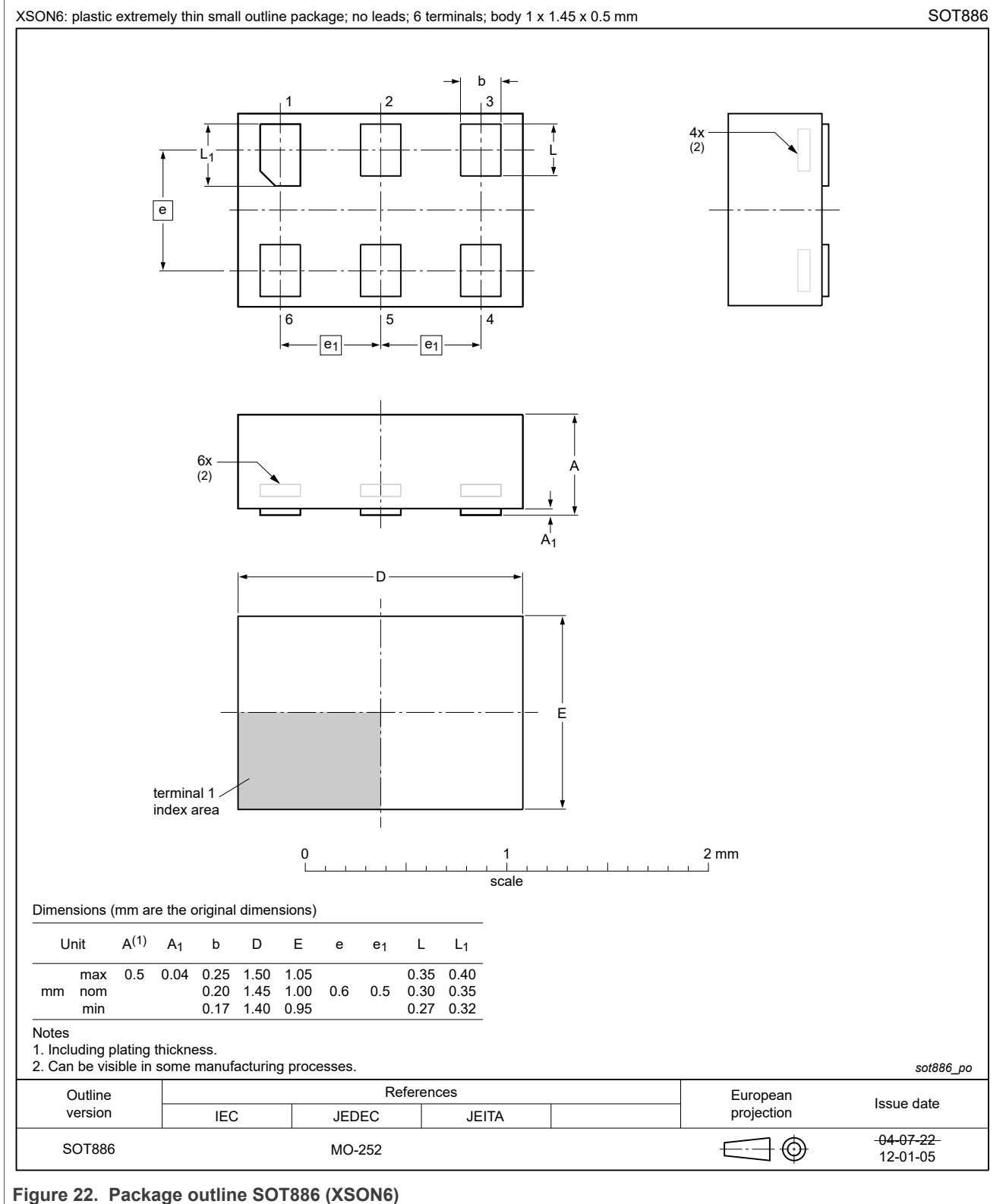

Figure 22. Package outline SOT886 (XSON6)

13 Abbreviations

Table 13. Abbreviations

Acronym	Description
CDM	Charged Device Model
CMOS	Complementary Metal-Oxide Semiconductor
ESD	ElectroStatic Discharge
HBM	Human Body Model
MM	Machine Model
PDA	Personal Digital Assistant
TTL	Transistor-Transistor Logic

14 Revision history

Table 14. Revision history

Document ID	Release date	Data sheet status	Change notice	Supersedes
NX3L1G3157 v.10.1	20201124	Product data sheet	-	NX3L1G3157 v.10
Modifications:	<ul style="list-style-type: none"> Package SOT886 requiring SSB added. Refer to PCN number 201909001 XSON6 (SOT886) Assembly/Test Transfer from ATGD and ATSN to ATBK Removed NX3L1G3157GW,125 			
NX3L1G3157 v.10	20120807	Product data sheet	-	NX3L1G3157 v.9
Modifications:	<ul style="list-style-type: none"> Package outline drawing of SOT886 (Figure 22) modified. 			
NX3L1G3157 v.9	20111109	Product data sheet	-	NX3L1G3157 v.8
Modifications:	<ul style="list-style-type: none"> Legal pages updated. 			
NX3L1G3157 v.8	20100426	Product data sheet	-	NX3L1G3157 v.7
NX3L1G3157 v.7	20100324	Product data sheet	-	NX3L1G3157 v.6
NX3L1G3157 v.6	20100208	Product data sheet	-	NX3L1G3157 v.5
NX3L1G3157 v.5	20090407	Product data sheet	-	NX3L1G3157 v.4
NX3L1G3157 v.4	20080730	Product data sheet	-	NX3L1G3157 v.3
NX3L1G3157 v.3	20080721	Product data sheet	-	NX3L1G3157 v.2
NX3L1G3157 v.2	20080415	Product data sheet	-	NX3L1G3157 v.1
NX3L1G3157 v.1	20071008	Product data sheet	-	-

15 Legal information

15.1 Data sheet status

Document status ^{[1][2]}	Product status ^[3]	Definition
Objective [short] data sheet	Development	This document contains data from the objective specification for product development.
Preliminary [short] data sheet	Qualification	This document contains data from the preliminary specification.
Product [short] data sheet	Production	This document contains the product specification.

[1] Please consult the most recently issued document before initiating or completing a design.

[2] The term 'short data sheet' is explained in section "Definitions".

[3] The product status of device(s) described in this document may have changed since this document was published and may differ in case of multiple devices. The latest product status information is available on the Internet at URL <http://www.nxp.com>.

15.2 Definitions

Draft — A draft status on a document indicates that the content is still under internal review and subject to formal approval, which may result in modifications or additions. NXP Semiconductors does not give any representations or warranties as to the accuracy or completeness of information included in a draft version of a document and shall have no liability for the consequences of use of such information.

Short data sheet — A short data sheet is an extract from a full data sheet with the same product type number(s) and title. A short data sheet is intended for quick reference only and should not be relied upon to contain detailed and full information. For detailed and full information see the relevant full data sheet, which is available on request via the local NXP Semiconductors sales office. In case of any inconsistency or conflict with the short data sheet, the full data sheet shall prevail.

Product specification — The information and data provided in a Product data sheet shall define the specification of the product as agreed between NXP Semiconductors and its customer, unless NXP Semiconductors and customer have explicitly agreed otherwise in writing. In no event however, shall an agreement be valid in which the NXP Semiconductors product is deemed to offer functions and qualities beyond those described in the Product data sheet.

15.3 Disclaimers

Limited warranty and liability — Information in this document is believed to be accurate and reliable. However, NXP Semiconductors does not give any representations or warranties, expressed or implied, as to the accuracy or completeness of such information and shall have no liability for the consequences of use of such information. NXP Semiconductors takes no responsibility for the content in this document if provided by an information source outside of NXP Semiconductors. In no event shall NXP Semiconductors be liable for any indirect, incidental, punitive, special or consequential damages (including - without limitation - lost profits, lost savings, business interruption, costs related to the removal or replacement of any products or rework charges) whether or not such damages are based on tort (including negligence), warranty, breach of contract or any other legal theory. Notwithstanding any damages that customer might incur for any reason whatsoever, NXP Semiconductors' aggregate and cumulative liability towards customer for the products described herein shall be limited in accordance with the Terms and conditions of commercial sale of NXP Semiconductors.

Right to make changes — NXP Semiconductors reserves the right to make changes to information published in this document, including without limitation specifications and product descriptions, at any time and without

notice. This document supersedes and replaces all information supplied prior to the publication hereof.

Suitability for use — NXP Semiconductors products are not designed, authorized or warranted to be suitable for use in life support, life-critical or safety-critical systems or equipment, nor in applications where failure or malfunction of an NXP Semiconductors product can reasonably be expected to result in personal injury, death or severe property or environmental damage. NXP Semiconductors and its suppliers accept no liability for inclusion and/or use of NXP Semiconductors products in such equipment or applications and therefore such inclusion and/or use is at the customer's own risk.

Applications — Applications that are described herein for any of these products are for illustrative purposes only. NXP Semiconductors makes no representation or warranty that such applications will be suitable for the specified use without further testing or modification. Customers are responsible for the design and operation of their applications and products using NXP Semiconductors products, and NXP Semiconductors accepts no liability for any assistance with applications or customer product design. It is customer's sole responsibility to determine whether the NXP Semiconductors product is suitable and fit for the customer's applications and products planned, as well as for the planned application and use of customer's third party customer(s). Customers should provide appropriate design and operating safeguards to minimize the risks associated with their applications and products. NXP Semiconductors does not accept any liability related to any default, damage, costs or problem which is based on any weakness or default in the customer's applications or products, or the application or use by customer's third party customer(s). Customer is responsible for doing all necessary testing for the customer's applications and products using NXP Semiconductors products in order to avoid a default of the applications and the products or of the application or use by customer's third party customer(s). NXP does not accept any liability in this respect.

Limiting values — Stress above one or more limiting values (as defined in the Absolute Maximum Ratings System of IEC 60134) will cause permanent damage to the device. Limiting values are stress ratings only and (proper) operation of the device at these or any other conditions above those given in the Recommended operating conditions section (if present) or the Characteristics sections of this document is not warranted. Constant or repeated exposure to limiting values will permanently and irreversibly affect the quality and reliability of the device.

Terms and conditions of commercial sale — NXP Semiconductors products are sold subject to the general terms and conditions of commercial sale, as published at <http://www.nxp.com/profile/terms>, unless otherwise agreed in a valid written individual agreement. In case an individual agreement is concluded only the terms and conditions of the respective agreement shall apply. NXP Semiconductors hereby expressly objects to applying the customer's general terms and conditions with regard to the purchase of NXP Semiconductors products by customer.

Low-ohmic single-pole double-throw analog switch

No offer to sell or license — Nothing in this document may be interpreted or construed as an offer to sell products that is open for acceptance or the grant, conveyance or implication of any license under any copyrights, patents or other industrial or intellectual property rights.

Export control — This document as well as the item(s) described herein may be subject to export control regulations. Export might require a prior authorization from competent authorities.

Non-automotive qualified products — Unless this data sheet expressly states that this specific NXP Semiconductors product is automotive qualified, the product is not suitable for automotive use. It is neither qualified nor tested in accordance with automotive testing or application requirements. NXP Semiconductors accepts no liability for inclusion and/or use of non-automotive qualified products in automotive equipment or applications. In the event that customer uses the product for design-in and use in automotive applications to automotive specifications and standards, customer (a) shall use the product without NXP Semiconductors' warranty of the product for

such automotive applications, use and specifications, and (b) whenever customer uses the product for automotive applications beyond NXP Semiconductors' specifications such use shall be solely at customer's own risk, and (c) customer fully indemnifies NXP Semiconductors for any liability, damages or failed product claims resulting from customer design and use of the product for automotive applications beyond NXP Semiconductors' standard warranty and NXP Semiconductors' product specifications.

Translations — A non-English (translated) version of a document is for reference only. The English version shall prevail in case of any discrepancy between the translated and English versions.

15.4 Trademarks

Notice: All referenced brands, product names, service names and trademarks are the property of their respective owners.

Tables

Tab. 1.	Ordering information	2	Tab. 8.	ON resistance	6
Tab. 2.	Ordering options	2	Tab. 9.	Dynamic characteristics	9
Tab. 3.	Pin description	3	Tab. 10.	Measurement points	10
Tab. 4.	Function table	3	Tab. 11.	Test data	11
Tab. 5.	Limiting values	3	Tab. 12.	Additional dynamic characteristics	12
Tab. 6.	Recommended operating conditions	4	Tab. 13.	Abbreviations	16
Tab. 7.	Static characteristics	4	Tab. 14.	Revision history	16

Figures

Fig. 1.	Logic symbol	2	Fig. 12.	ON resistance as a function of input voltage; VCC = 3.3 V	8
Fig. 2.	Logic diagram	2	Fig. 13.	ON resistance as a function of input voltage; VCC = 4.3 V	8
Fig. 3.	Pin configuration SOT886 (XSON6)	3	Fig. 14.	Enable and disable times	10
Fig. 4.	Test circuit for measuring OFF-state leakage current	5	Fig. 15.	Test circuit for measuring break-before-make timing	11
Fig. 5.	Test circuit for measuring ON-state leakage current	6	Fig. 16.	Load circuit for switching times	11
Fig. 6.	Test circuit for measuring ON resistance	7	Fig. 17.	Test circuit for measuring total harmonic distortion	12
Fig. 7.	Typical ON resistance as a function of input voltage	7	Fig. 18.	Test circuit for measuring the frequency response when channel is in ON-state	13
Fig. 8.	ON resistance as a function of input voltage; VCC = 1.5 V	7	Fig. 19.	Test circuit for measuring isolation (OFF-state)	13
Fig. 9.	ON resistance as a function of input voltage; VCC = 1.8 V	7	Fig. 20.	Test circuit for measuring crosstalk voltage between digital inputs and switch	14
Fig. 10.	ON resistance as a function of input voltage; VCC = 2.5 V	8	Fig. 21.	Test circuit for measuring charge injection	14
Fig. 11.	ON resistance as a function of input voltage; VCC = 2.7 V	8	Fig. 22.	Package outline SOT886 (XSON6)	15

Contents

1	General description	1
2	Features and benefits	1
3	Applications	1
4	Ordering information	2
4.1	Ordering options	2
5	Functional diagram	2
6	Pinning information	2
6.1	Pinning	3
6.2	Pin description	3
7	Functional description	3
8	Limiting values	3
9	Recommended operating conditions	4
10	Static characteristics	4
10.1	Test circuits	5
10.2	ON resistance	6
10.3	ON resistance test circuit and graphs	7
11	Dynamic characteristics	9
11.1	Waveform and test circuits	10
11.2	Additional dynamic characteristics	12
11.3	Test circuits	12
12	Package outline	15
13	Abbreviations	16
14	Revision history	16
15	Legal information	17

Please be aware that important notices concerning this document and the product(s) described herein, have been included in section 'Legal information'.

© NXP B.V. 2020.

All rights reserved.

For more information, please visit: <http://www.nxp.com>

For sales office addresses, please send an email to: salesaddresses@nxp.com

Date of release: 24 November 2020
Document identifier: NX3L1G3157

X-ON Electronics

Largest Supplier of Electrical and Electronic Components

Click to view similar products for [Analogue Switch ICs](#) category:

Click to view products by [NXP](#) manufacturer:

Other Similar products are found below :

[FSA3051TMX](#) [NLAS4684FCTCG](#) [NLAS5223BLMNR2G](#) [NLX2G66DMUTCG](#) [425541DB](#) [425528R](#) [099044FB](#) [NLAS5123MNR2G](#)
[PI5A4157CEX](#) [NLAS4717EPFCT1G](#) [PI5A3167CCEX](#) [SLAS3158MNR2G](#) [PI5A392AQE](#) [PI5A4157ZUEX](#) [PI5A3166TAEX](#) [FSA634UCX](#)
[XS3A1T3157GMX](#) [TC4066BP\(N,F\)](#) [DG302BDJ-E3](#) [PI5A100QEX](#) [HV2605FG-G](#) [HV2301FG-G](#) [RS2117YUTQK10](#) [RS2118YUTQK10](#)
[RS2227XUTQK10](#) [ADG452BRZ-REEL7](#) [MAX4066ESD+](#) [MAX391CPE+](#) [MAX4730EXT+T](#) [MAX314CPE+](#) [BU4066BCFV-E2](#)
[MAX313CPE+](#) [BU4S66G2-TR](#) [NLASB3157MTR2G](#) [TS3A4751PWR](#) [NLAST4599DFT2G](#) [NLAST4599DTT1G](#) [DG300BDJ-E3](#)
[DG2503DB-T2-GE1](#) [TC4W53FU\(TE12L,F\)](#) [74HC2G66DC.125](#) [DG3257DN-T1-GE4](#) [ADG619BRMZ-REEL](#) [ADG1611BRUZ-REEL7](#)
[DG2535EDQ-T1-GE3](#) [LTC201ACN#PBF](#) [74LV4066DB,118](#) [ISL43410IUZ](#) [FSA2275AUMX](#) [DIO1500WL12](#)