

# NX5DV330

## Quad 1-of-2 video multiplexer/demultiplexer

Rev. 03 — 5 August 2009

Product data sheet

## 1. General description

---

The NX5DV330 is a quad 1-of-2 high-speed TTL-compatible video multiplexer/demultiplexer. The low ON resistance of the switch allows inputs to be connected to outputs without adding propagation delay or generating additional ground bounce noise

It has a digital select input (S), four independent inputs/outputs (nY0, nY1), a common input/output (nZ) and an active LOW enable input ( $\bar{E}$ ). When pin  $\bar{E}$  is HIGH, the switch is turned off.

Schmitt-trigger action at the enable input ( $\bar{E}$ ) and select input (S) makes the circuit tolerant to slower input rise and fall times across the entire  $V_{CC}$  range from 4.0 V to 5.5 V.

The NX5DV330 is characterized for operation from  $-40\text{ }^{\circ}\text{C}$  to  $+85\text{ }^{\circ}\text{C}$ .

## 2. Features

---

- $5\ \Omega$  switch connection between two ports
- TTL-compatible input levels
- Minimal propagation delay through the switch
- ESD protection:
  - ◆ HBM JESD22-A114E Class 2A exceeds 2000 V
  - ◆ MM JESD22-A115-A exceeds 200 V
  - ◆ CDM JESD22-C101C exceeds 1000 V
- Latch-up testing is done to JEDEC standard JESD78 which exceeds 100 mA

### 3. Ordering information

**Table 1. Ordering information**

Type number	Package			Version
	Temperature range	Name	Description	
NX5DV330D	-40 °C to +85 °C	SO16	plastic small outline package; 16 leads; body width 3.9 mm	SOT109-1
NX5DV330DS	-40 °C to +85 °C	SSOP16 <sup>[1]</sup>	plastic shrink small outline package; 16 leads; body width 3.9 mm; lead pitch 0.635 mm	SOT519-1
NX5DV330PW	-40 °C to +85 °C	TSSOP16	plastic thin shrink small outline package; 16 leads; body width 4.4 mm	SOT403-1
NX5DV330BQ	-40 °C to +85 °C	DHVQFN16	plastic dual in-line compatible thermal enhanced very thin quad flat package; no leads; 16 terminals; body 2.5 × 3.5 × 0.85 mm	SOT763-1

[1] Also known as QSOP16.

### 4. Functional diagram

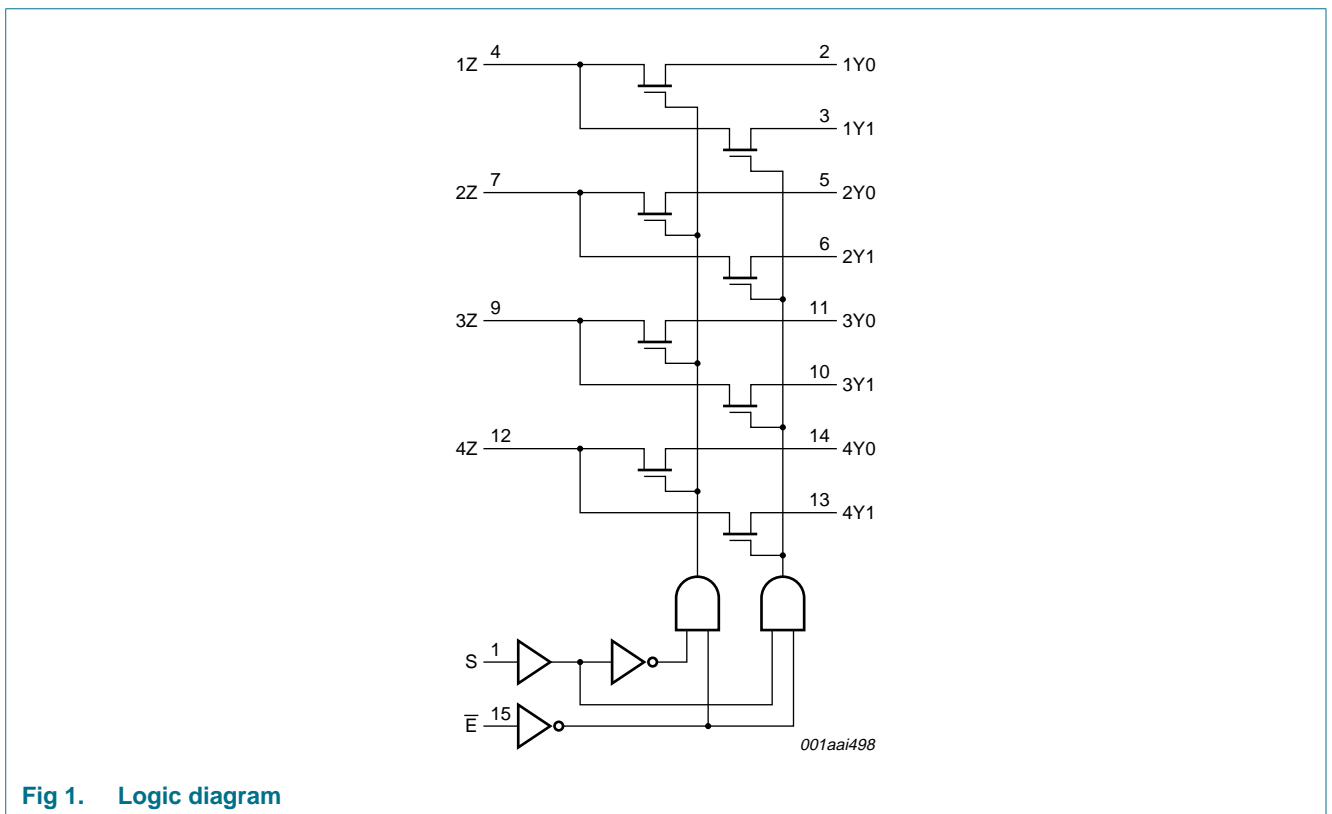

**Fig 1. Logic diagram**

## 5. Pinning information

### 5.1 Pinning

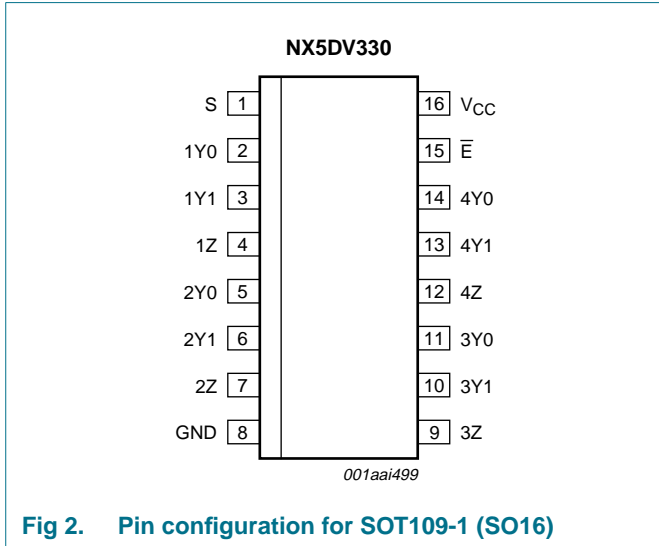

Fig 2. Pin configuration for SOT109-1 (SO16)

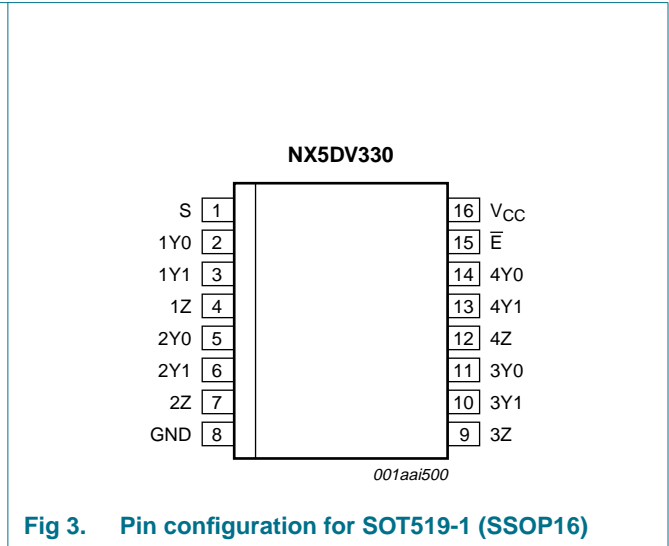

Fig 3. Pin configuration for SOT519-1 (SSOP16)

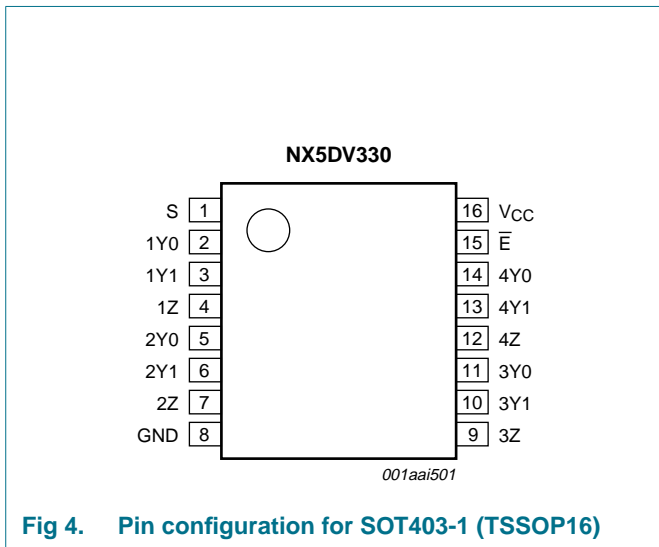

Fig 4. Pin configuration for SOT403-1 (TSSOP16)

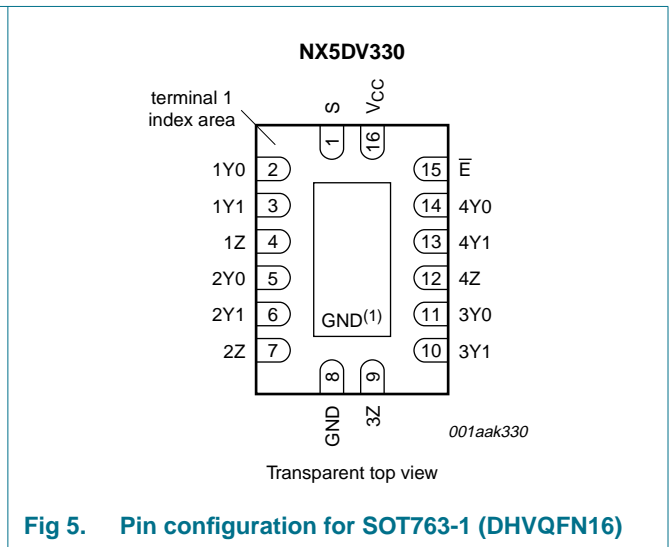

Fig 5. Pin configuration for SOT763-1 (DHWQFN16)

### 5.2 Pin description

Table 2. Pin description

Symbol	Pin	Description
S	1	select control input
1Y0, 1Y1, 2Y0, 2Y1, 3Y1, 3Y0, 4Y1, 4Y0	2, 3, 5, 6, 10, 11, 13, 14	independent input or output
1Z, 2Z, 3Z, 4Z	4, 7, 9, 12	independent input or output
GND	8	ground (0 V)
$\bar{E}$	15	enable input (active LOW)
V <sub>CC</sub>	16	positive supply voltage

## 6. Functional description

**Table 3. Function selection**

H = HIGH voltage level; L = LOW voltage level; X = Don't care.

Input		Switch
$\bar{E}$	S	
L	L	Y0 to Z or Z to Y0
L	H	Y1 to Z or Z to Y1
H	X	switch off

## 7. Limiting values

**Table 4. Limiting values**

In accordance with the Absolute Maximum Rating System (IEC 60134).

Symbol	Parameter	Conditions	Min	Max	Unit
$V_{CC}$	supply voltage		-0.5	+7.0	V
$V_I$	input voltage		[1] -0.5	+7.0	V
$I_{SW}$	switch current	continuous current through each switch	-	128	mA
$I_{IK}$	input clamping current	$V_I < 0$ V	-	-50	mA
$T_{stg}$	storage temperature		-65	+150	°C
$P_{tot}$	total power dissipation		[2][3][4] -	500	mW

[1] The input and output negative voltage ratings may be exceeded if the input and output clamp current ratings are observed.

[2] For SO16 package:  $P_{tot}$  derates linearly with 8 mW/K above 70 °C.

[3] For SSOP16 (QSOP16) and TSSOP16 packages:  $P_{tot}$  derates linearly with 5.5 mW/K above 60 °C.

[4] For DHVQFN16 packages: above 60 °C derate linearly with 4.5 mW/K.

## 8. Recommended operating conditions

**Table 5. Operating conditions**

All unused control inputs of the device must be held at  $V_{CC}$  or GND to ensure proper device operation.

Symbol	Parameter	Conditions	Min	Typ	Max	Unit
$V_{CC}$	supply voltage		4.0	5.0	5.5	V
$V_{IH}$	HIGH-level input voltage		2.0	-	-	V
$V_{IL}$	LOW-level input voltage		-	-	0.8	V
$V_H$	hysteresis voltage	pin S, $\bar{E}$	-	45	-	mV
$T_{amb}$	ambient temperature	operating in free-air	-40	+25	+85	°C

## 9. Static characteristics

**Table 6. Static characteristics**

$T_{amb} = -40\text{ }^{\circ}\text{C}$  to  $+85\text{ }^{\circ}\text{C}$ .

Symbol	Parameter	Conditions	Min	Typ <sup>[1]</sup>	Max	Unit
$V_{IK}$	input clamping voltage	$V_{CC} = 4.5\text{ V}$ ; $I_I = -18\text{ mA}$	-	-	-1.2	V
$I_I$	input leakage current	pin S, $\bar{E}$ ; $V_{CC} = 5.5\text{ V}$ ; $V_I = \text{GND}$ or $5.5\text{ V}$	-	-	$\pm 1$	$\mu\text{A}$
$I_{S(OFF)}$	OFF-state leakage current	$V_{CC} = 5.5\text{ V}$ ; $V_I = \text{GND}$ ; $V_O = 0\text{ V}$ to $5.5\text{ V}$	-	-	$\pm 1$	$\mu\text{A}$
$I_{OFF}$	power-off leakage current	$V_{CC} = 0\text{ V}$ ; $V_I = V_O = 0\text{ V}$ to $5.5\text{ V}$	-	-	$\pm 1$	$\mu\text{A}$
$I_{CC}$	supply current	$V_{CC} = 5.5\text{ V}$ ; $I_O = 0\text{ mA}$ ; $V_I = V_{CC}$ or $\text{GND}$	-	-	3	$\mu\text{A}$
$\Delta I_{CC}$	additional supply current	pin S, $\bar{E}$ ; $V_{CC} = 5.5\text{ V}$ ; one input at $3.4\text{ V}$ , other inputs at $V_{CC}$ or $\text{GND}$	<sup>[2]</sup> -	-	2.5	mA
$C_I$	input capacitance	pin S, $\bar{E}$ ; $V_I = 5\text{ V}$ or $0\text{ V}$	-	3.5	-	pF
$C_{io(off)}$	off-state input/output capacitance	Z port; $V_{CC} = 5\text{ V}$ ; $V_O = 5\text{ V}$ or $0\text{ V}$ ; $\bar{E} = V_{CC}$	-	6.0	-	pF
		Y port; $V_{CC} = 5\text{ V}$ ; $V_O = 5\text{ V}$ or $0\text{ V}$ ; $\bar{E} = V_{CC}$	-	4.0	-	pF
$C_{io(on)}$	on-state input/output capacitance	Z port; $V_{CC} = 5\text{ V}$ ; $V_O = 5\text{ V}$ or $0\text{ V}$ ; $\bar{E} = \text{GND}$	-	14	-	pF
$R_{ON}$	ON resistance	$V_{CC} = 4.5\text{ V}$	<sup>[3]</sup>			
		$V_I = 1.0\text{ V}$ ; $I_I = 13\text{ mA}$	-	3	7	$\Omega$
		$V_I = 2.0\text{ V}$ ; $I_I = 26\text{ mA}$	-	7	10	$\Omega$

[1] All typical values are measured at  $V_{CC} = 5\text{ V}$ ;  $T_{amb} = 25\text{ }^{\circ}\text{C}$ .

[2] This is the increase in supply current for each input that is at the specified TTL voltage level rather than  $V_{CC}$  or  $\text{GND}$ .

[3] Measured by the voltage drop between the Z and the Y terminals at the indicated current through the switch. ON-state resistance is determined by the lowest voltage of the two (Z or Y) terminals.

## 10. Dynamic characteristics

**Table 7. Dynamic characteristics**

$T_{amb} = -40\text{ }^{\circ}\text{C}$  to  $+85\text{ }^{\circ}\text{C}$ ; for test circuit see [Figure 7](#).

Symbol	Parameter	Conditions	Min	Typ	Max	Unit
$t_{on}$	turn-on time	S to nZ; see <a href="#">Figure 6</a>				
		$V_{CC} = 4.5\text{ V}$ to $5.5\text{ V}$	-	4.0	6.0	ns
$t_{off}$	turn-off time	S to nZ; see <a href="#">Figure 6</a>				
		$V_{CC} = 4.5\text{ V}$ to $5.5\text{ V}$	-	2.3	6.0	ns

### 11. Waveforms

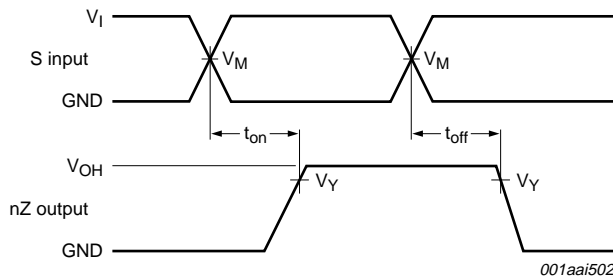

Measurement points are given in [Table 8](#).  
 $V_{OH}$  is the typical voltage output level that occurs with the output load.

**Fig 6. Input (S) to output (nZ) turn-on and turn-off time**

**Table 8. Measurement points**

Supply voltage	Input		Output
$V_{CC}$	$V_I$	$V_M$	$V_Y$
4.5 V to 5.5 V	GND to 3.0 V	1.5 V	$0.9V_{OH}$

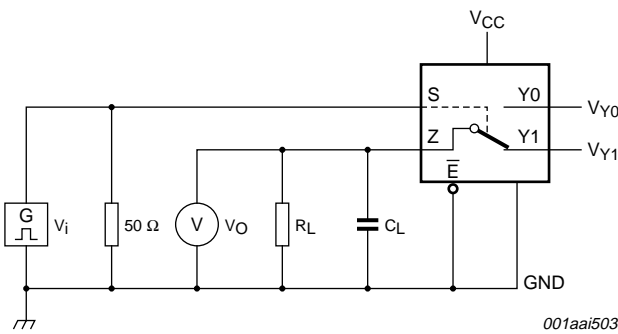

Test data is given in [Table 9](#).  
 Definitions test circuit:  
 $R_L$  = Load resistance.  
 $C_L$  = Load capacitance including jig and probe capacitance.

**Fig 7. Test circuit for measuring turn-on and turn-off times**

**Table 9. Test data**

Input				Load		
$V_I$	$f_i$	$t_r, t_f$	$V_{Y0}$	$V_{Y1}$	$R_L$	$C_L$
GND to 3.0 V	$\leq 10$ MHz	$\leq 2.5$ ns	GND to 3.0 V	3.0 V to GND	$75 \Omega$	20 pF

## 12. Additional dynamic characteristics

**Table 10. Additional dynamic characteristics**

At recommended operating conditions; voltages are referenced to GND (ground = 0 V);  $V_I = GND$  or  $V_{CC}$  (unless otherwise specified);  $T_{amb} = 25\text{ }^\circ\text{C}$ ;  $V_{CC} = 4.5\text{ V to }5.5\text{ V}$ .

Symbol	Parameter	Conditions	Min	Typ	Max	Unit
$G_{dif}$	differential gain	$f_i = 3.58\text{ MHz}$ ; $R_L = 150\ \Omega$	-	0.64	-	%
$\phi_{dif}$	differential phase	$f_i = 3.58\text{ MHz}$ ; $R_L = 150\ \Omega$	-	0.1	-	deg
$f_{(-3dB)}$	-3 dB frequency response	$R_L = 150\ \Omega$ ; see <a href="#">Figure 8</a>	300	-	-	MHz
$\alpha_{iso}$	isolation (OFF-state)	$f_i = 10\text{ MHz}$ ; $R_L = 150\ \Omega$ ; see <a href="#">Figure 9</a>	-	-60	-	dB
Xtalk	crosstalk	between switches; see <a href="#">Figure 10</a> ; $f_i = 10\text{ MHz}$ ; $R_L = 150\ \Omega$ ; $R_i = 10\ \Omega$	[1]	-63	-	dB

[1] All unused analog input pins (nZ) and outputs pins (nYn) are connected through 10  $\Omega$  and 50  $\Omega$  pull-down resistors, respectively.

## 13. Test circuits

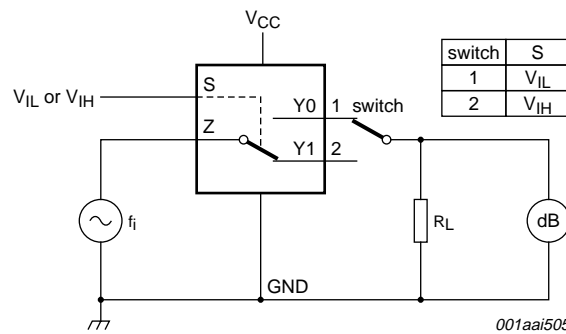

Adjust  $f_i$  voltage to obtain 0 dBm level at output. Increase  $f_i$  frequency until dB meter reads -3 dB.

**Fig 8. Test circuit for measuring the frequency response when channel is in ON-state**

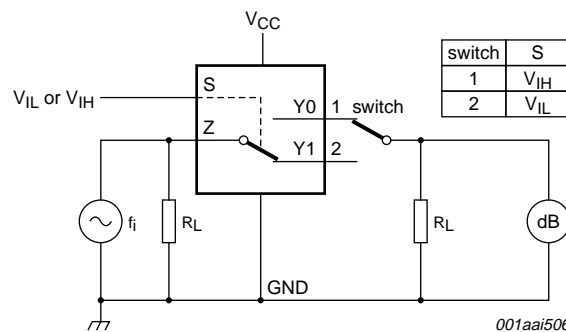

Adjust  $f_i$  voltage to obtain 0 dBm level at input.

**Fig 9. Test circuit for measuring isolation (OFF-state)**

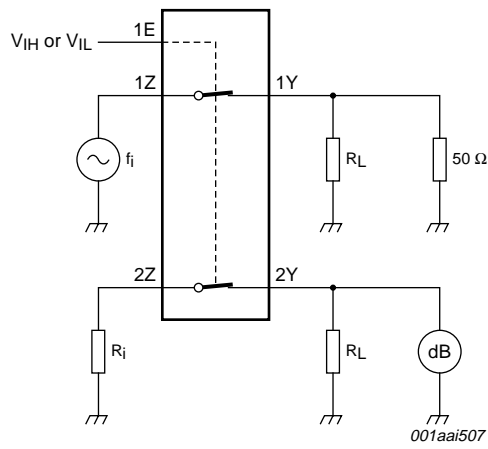

Adjust  $f_i$  voltage to obtain 0 dBm level at input.

**Fig 10. Test circuit for measuring crosstalk voltage between digital inputs and switch**



14. Package outline

SO16: plastic small outline package; 16 leads; body width 3.9 mm

SOT109-1

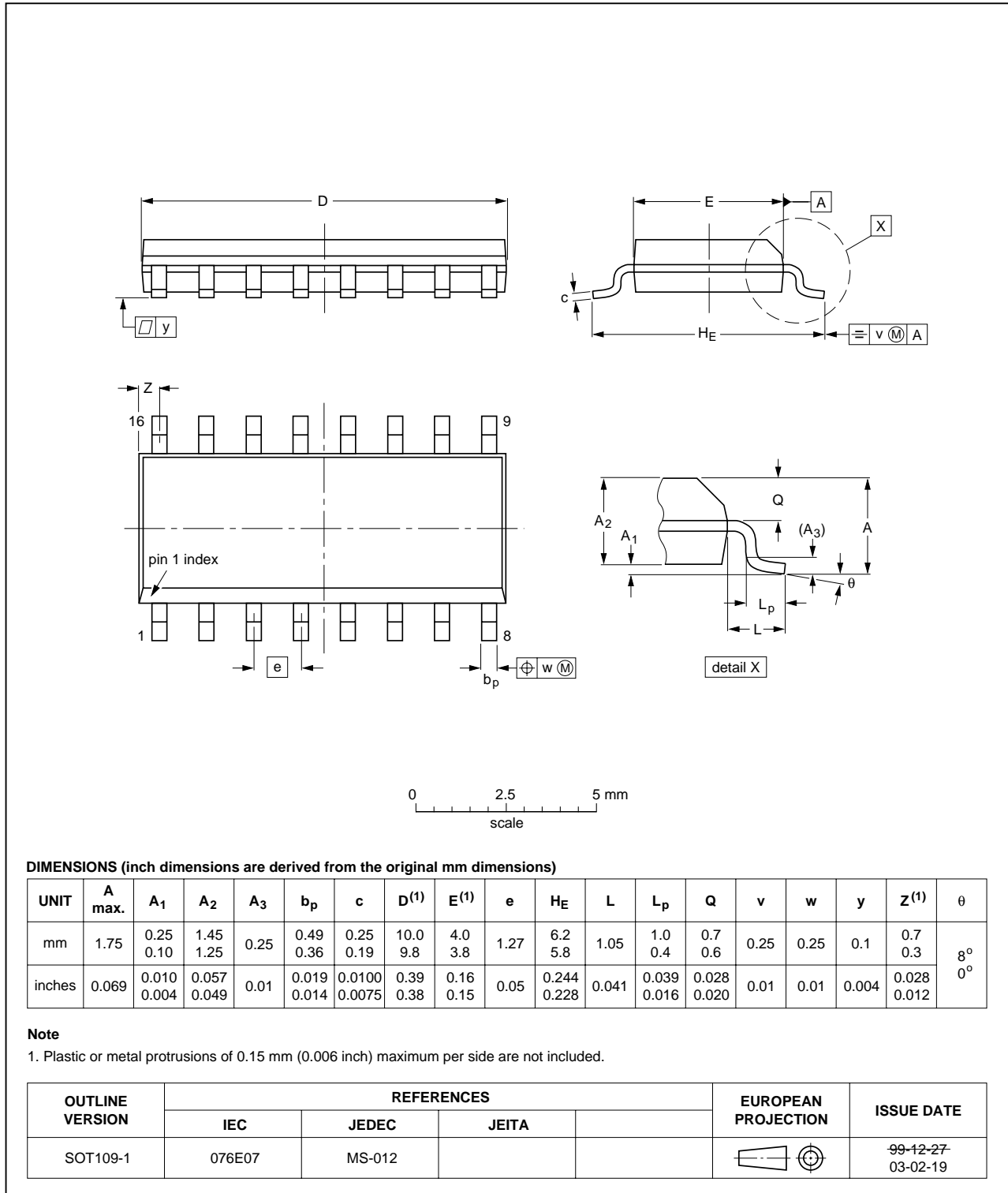

Fig 11. Package outline SOT109-1 (SO16)

SSOP16: plastic shrink small outline package; 16 leads; body width 3.9 mm; lead pitch 0.635 mm SOT519-1

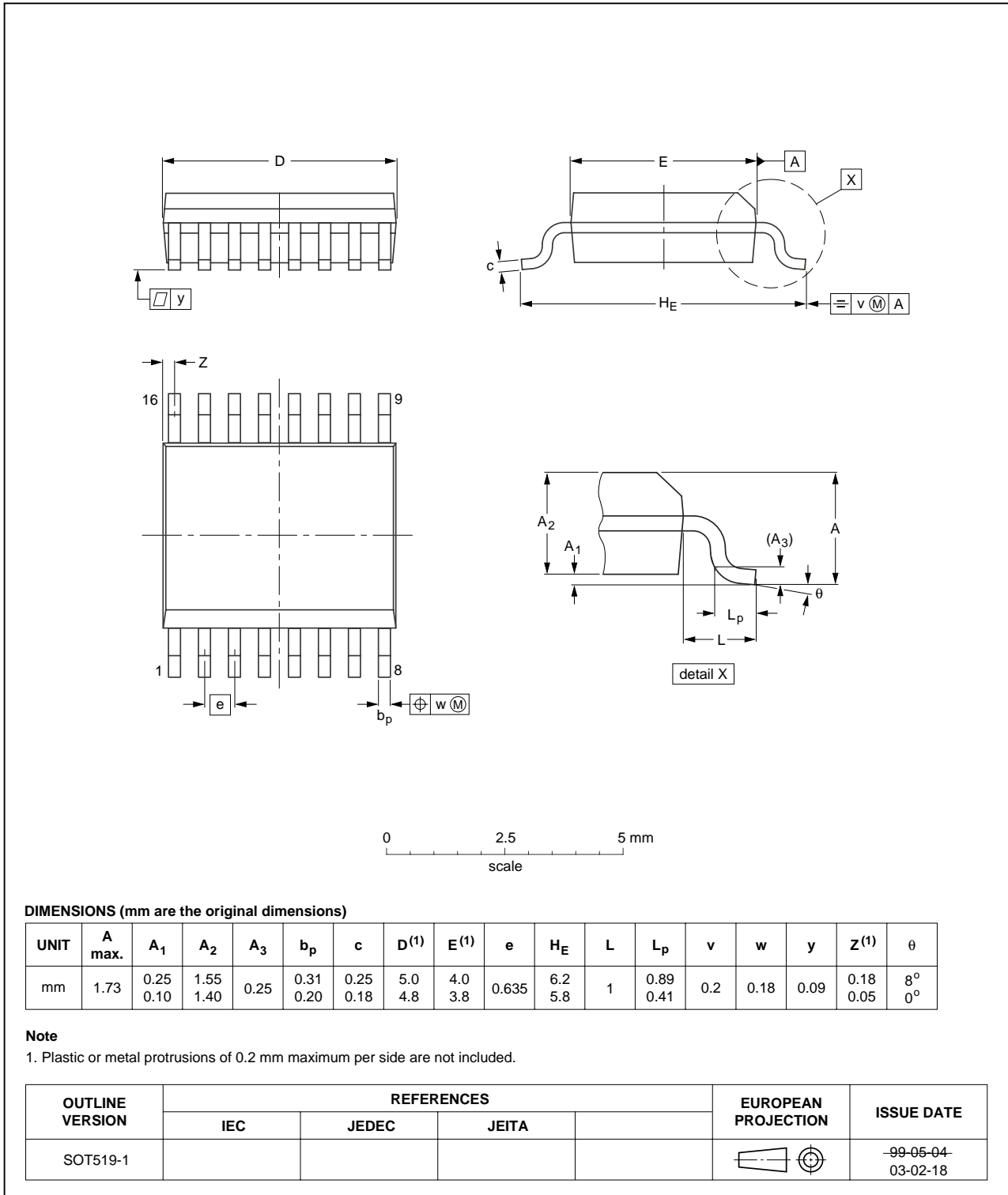

Fig 12. Package outline SOT519-1 (SSOP16)

TSSOP16: plastic thin shrink small outline package; 16 leads; body width 4.4 mm

SOT403-1



Fig 13. Package outline SOT403-1 (TSSOP16)

DHVQFN16: plastic dual in-line compatible thermal enhanced very thin quad flat package; no leads; 16 terminals; body 2.5 x 3.5 x 0.85 mm

SOT763-1

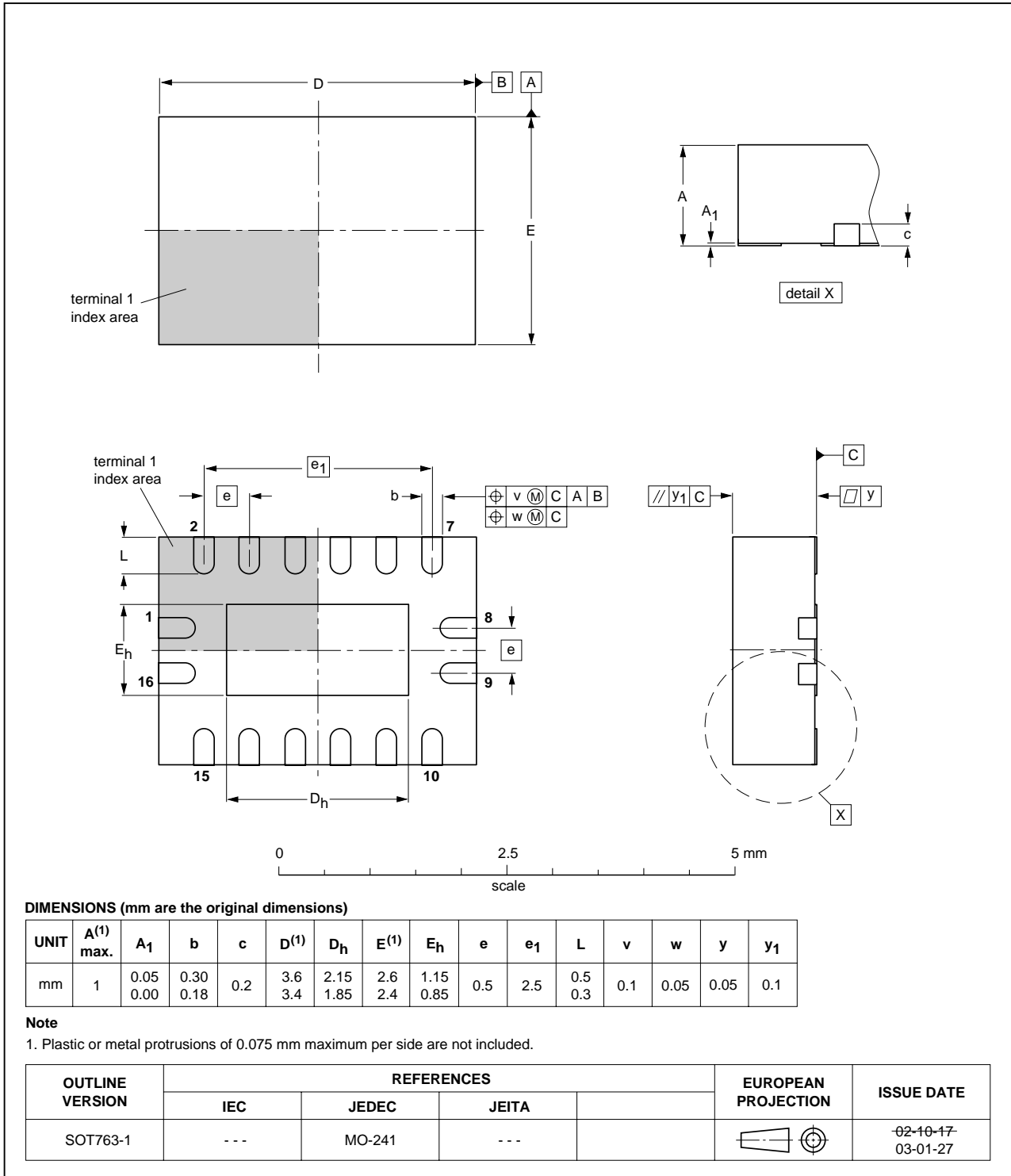

Fig 14. Package outline SOT763-1 (DHVQFN16)

## 15. Abbreviations

Table 11. Abbreviations

Acronym	Description
CDM	Charged Device Model
ESD	ElectroStatic Discharge
HBM	Human Body Model
MM	Machine Model
TTL	Transistor-Transistor Logic

## 16. Revision history

Table 12. Revision history

Document ID	Release date	Data sheet status	Change notice	Supersedes
NX5DV330_3	20090805	Product data sheet	-	NX5DV330_2
Modifications:	• Added type number NX5DV330BQ (DHVQFN16 package)			
NX5DV330_2	20080825	Product data sheet	-	NX5DV330_1
NX5DV330_1	20080815	Product data sheet	-	-

## 17. Legal information

### 17.1 Data sheet status

Document status <sup>[1][2]</sup>	Product status <sup>[3]</sup>	Definition
Objective [short] data sheet	Development	This document contains data from the objective specification for product development.
Preliminary [short] data sheet	Qualification	This document contains data from the preliminary specification.
Product [short] data sheet	Production	This document contains the product specification.

[1] Please consult the most recently issued document before initiating or completing a design.

[2] The term 'short data sheet' is explained in section "Definitions".

[3] The product status of device(s) described in this document may have changed since this document was published and may differ in case of multiple devices. The latest product status information is available on the Internet at URL <http://www.nxp.com>.

### 17.2 Definitions

**Draft** — The document is a draft version only. The content is still under internal review and subject to formal approval, which may result in modifications or additions. NXP Semiconductors does not give any representations or warranties as to the accuracy or completeness of information included herein and shall have no liability for the consequences of use of such information.

**Short data sheet** — A short data sheet is an extract from a full data sheet with the same product type number(s) and title. A short data sheet is intended for quick reference only and should not be relied upon to contain detailed and full information. For detailed and full information see the relevant full data sheet, which is available on request via the local NXP Semiconductors sales office. In case of any inconsistency or conflict with the short data sheet, the full data sheet shall prevail.

### 17.3 Disclaimers

**General** — Information in this document is believed to be accurate and reliable. However, NXP Semiconductors does not give any representations or warranties, expressed or implied, as to the accuracy or completeness of such information and shall have no liability for the consequences of use of such information.

**Right to make changes** — NXP Semiconductors reserves the right to make changes to information published in this document, including without limitation specifications and product descriptions, at any time and without notice. This document supersedes and replaces all information supplied prior to the publication hereof.

**Suitability for use** — NXP Semiconductors products are not designed, authorized or warranted to be suitable for use in medical, military, aircraft, space or life support equipment, nor in applications where failure or malfunction of an NXP Semiconductors product can reasonably be expected to result in personal injury, death or severe property or environmental

damage. NXP Semiconductors accepts no liability for inclusion and/or use of NXP Semiconductors products in such equipment or applications and therefore such inclusion and/or use is at the customer's own risk.

**Applications** — Applications that are described herein for any of these products are for illustrative purposes only. NXP Semiconductors makes no representation or warranty that such applications will be suitable for the specified use without further testing or modification.

**Limiting values** — Stress above one or more limiting values (as defined in the Absolute Maximum Ratings System of IEC 60134) may cause permanent damage to the device. Limiting values are stress ratings only and operation of the device at these or any other conditions above those given in the Characteristics sections of this document is not implied. Exposure to limiting values for extended periods may affect device reliability.

**Terms and conditions of sale** — NXP Semiconductors products are sold subject to the general terms and conditions of commercial sale, as published at <http://www.nxp.com/profile/terms>, including those pertaining to warranty, intellectual property rights infringement and limitation of liability, unless explicitly otherwise agreed to in writing by NXP Semiconductors. In case of any inconsistency or conflict between information in this document and such terms and conditions, the latter will prevail.

**No offer to sell or license** — Nothing in this document may be interpreted or construed as an offer to sell products that is open for acceptance or the grant, conveyance or implication of any license under any copyrights, patents or other industrial or intellectual property rights.

**Export control** — This document as well as the item(s) described herein may be subject to export control regulations. Export might require a prior authorization from national authorities.

### 17.4 Trademarks

Notice: All referenced brands, product names, service names and trademarks are the property of their respective owners.

## 18. Contact information

For more information, please visit: <http://www.nxp.com>

For sales office addresses, please send an email to: [salesaddresses@nxp.com](mailto:salesaddresses@nxp.com)

**19. Contents**

**1 General description . . . . . 1**

**2 Features . . . . . 1**

**3 Ordering information . . . . . 2**

**4 Functional diagram . . . . . 2**

**5 Pinning information . . . . . 3**

5.1 Pinning . . . . . 3

5.2 Pin description . . . . . 3

**6 Functional description . . . . . 4**

**7 Limiting values . . . . . 4**

**8 Recommended operating conditions . . . . . 4**

**9 Static characteristics . . . . . 5**

**10 Dynamic characteristics . . . . . 5**

**11 Waveforms . . . . . 6**

**12 Additional dynamic characteristics . . . . . 7**

**13 Test circuits . . . . . 7**

**14 Package outline . . . . . 9**

**15 Abbreviations . . . . . 13**

**16 Revision history . . . . . 13**

**17 Legal information . . . . . 14**

17.1 Data sheet status . . . . . 14

17.2 Definitions . . . . . 14

17.3 Disclaimers . . . . . 14

17.4 Trademarks . . . . . 14

**18 Contact information . . . . . 14**

**19 Contents . . . . . 15**

Please be aware that important notices concerning this document and the product(s) described herein, have been included in section 'Legal information'.



© NXP B.V. 2009.

All rights reserved.

For more information, please visit: <http://www.nxp.com>

For sales office addresses, please send an email to: [salesaddresses@nxp.com](mailto:salesaddresses@nxp.com)

Date of release: 5 August 2009

Document identifier: NX5DV330\_3

## X-ON Electronics

Largest Supplier of Electrical and Electronic Components

*Click to view similar products for [Multiplexer Switch ICs](#) category:*

*Click to view products by [NXP](#) manufacturer:*

Other Similar products are found below :

[M74HCT4066ADTR2G](#) [ADG506ATE/883B](#) [DG406BDN-T1-E3](#) [JM38510/19004BXA](#) [HEF4051BP](#) [5962-8512704XA](#)

[NLAS5223CMUTAG](#) [NLV14051BDG](#) [NLVHC4051ADTR2G](#) [JM38510/19002BXA](#) [016400E](#) [ADV3014KSTZ](#) [PI3V512QE](#) [FSA644UCX](#)

[FSA9591UCX](#) [FSSD07BQX](#) [MAX7356ETG](#) [NLV74HCT4851ADRG](#) [7705201EC](#) [MAX4634ETBT](#) [MAX4578CAP+](#) [PI2SSD3212NCE](#)

[MAX3997ETM+](#) [NLV14052BDTR2G](#) [PI3L100QE](#) [PI3DBS12412AZLEX](#) [PI3V512QEX](#) [MAX4969CTO+](#) [PI3DBS12212AZBEX](#)

[PI3DBS16415ZHEX](#) [MAX7367EUP+T](#) [MAX7369EUP+](#) [MAX7357ETG+T](#) [NLV74HC4053ADR2G](#) [NLVAST4051DTR2G](#)

[PI3DBS12412AZHEX](#) [ADG5209BCPZ-RL7](#) [PS509WEX](#) [PS509QEX](#) [PS508QEX](#) [PS508WEX](#) [ADG5209FBRUZ-RL7](#) [ADG5208FBRUZ-](#)

[RL7](#) [MAX14984ETG+](#) [MAX14984ETG+T](#) [HV2818/R4X](#) [HV2918/R4X](#) [CBTU02044HEJ](#) [PS508LEX](#) [PS509LEX](#)