



LPC3152/3154

ARM926EJ microcontrollers with USB High-speed OTG, SD/MMC, NAND flash controller, and audio codec

Rev. 1 — 31 May 2012

Product data sheet

1. General description

The NXP LPC3152/3154 combine an 180 MHz ARM926EJ-S CPU core, High-speed USB 2.0 OTG, 192 kB SRAM, NAND flash controller, flexible external bus interface, an integrated audio codec, Li-ion charger, Real-Time Clock (RTC), and a myriad of serial and parallel interfaces in a single chip targeted at consumer, industrial, medical, and communication markets. To optimize system power consumption, the LPC3152/3154 have multiple power domains and a very flexible Clock Generation Unit (CGU) that provides dynamic clock gating and scaling.

The LPC3152/3154 are implemented as a multi-chip module with two side-by-side dies, one for digital functions and one for analog functions, which include Power Supply Unit (PSU), audio codec, RTC, and Li-ion battery charger.

2. Features and benefits

2.1 Key features

- CPU platform
 - ◆ 180 MHz, 32-bit ARM926EJ-S
 - ◆ 16 kB D-cache and 16 kB I-cache
 - ◆ Memory Management Unit (MMU)
- Internal memory
 - ◆ 192 kB embedded SRAM
- External memory interface
 - ◆ NAND flash controller with 8-bit ECC and AES decryption engine (LPC3154 only)
 - ◆ 8/16-bit Multi-Port Memory Controller (MPMC): SDRAM and SRAM
- Security
 - ◆ AES decryption engine (LPC3154 only)
 - ◆ Secure one-time programmable memory for AES key storage and customer use
 - ◆ 128 bit unique ID per device for DRM schemes
- Communication and connectivity
 - ◆ High-speed USB 2.0 (OTG, Host, Device) with on-chip PHY
 - ◆ Two I²S-bus interfaces
 - ◆ Integrated master/slave SPI
 - ◆ Two master/slave I²C-bus interfaces
 - ◆ Fast UART
 - ◆ Memory Card Interface (MCI): MMC/SD/SDIO/CE-ATA



- ◆ Three-channel 10-bit ADC
- ◆ Integrated 4/8/16-bit 6800/8080 compatible LCD interface
- ◆ Integrated audio codec with stereo ADC and Class AB headphone amplifier
- System functions
 - ◆ Dynamic clock gating and scaling
 - ◆ Multiple power domains
 - ◆ Selectable boot-up: SPI flash, NAND flash, SD/MMC cards, UART, or USB
 - ◆ On the LPC3154 only: secure booting using AES decryption engine from SPI flash, NAND flash, SD/MMC cards, UART, or USB
 - ◆ DMA controller
 - ◆ Four 32-bit timers
 - ◆ Watchdog timer
 - ◆ PWM module
 - ◆ Master/slave PCM interface
 - ◆ Random Number Generator (RNG)
 - ◆ General Purpose I/O (GPIO) pins
 - ◆ Flexible and versatile interrupt structure
 - ◆ JTAG interface with boundary scan and ARM debug access
 - ◆ Real-Time Clock (RTC)
- Power supply
 - ◆ Integrated power supply unit
 - ◆ Li-ion charger
 - ◆ USB charge pump
- Operating voltage and temperature
 - ◆ Core voltage: 1.2 V
 - ◆ I/O voltage: 1.8 V, 3.3 V
 - ◆ Temperature: -40 °C to +85 °C
- TFBGA208 package: 12 × 12 mm², 0.7 mm pitch

3. Ordering information

Table 1. Ordering information

Type number	Package		Version
	Name	Description	
LPC3152FET208	TFBGA208	TFBGA208: plastic thin fine-pitch ball grid array package; 208 balls; body 12 x 12 x 0.7 mm	SOT930-1
LPC3154FET208	TFBGA208	TFBGA208: plastic thin fine-pitch ball grid array package; 208 balls; body 12 x 12 x 0.7 mm	SOT930-1

3.1 Ordering options

Table 2. Ordering options for LPC3152/54

Type number	Total SRAM	NAND Flash Controller	Security engine AES	High-speed USB	10-bit ADC channels	Audio codec, PSU, RTC, Li-ion charger	MCI SDHC/SDIO/CE-ATA	Pins	Temperature range
LPC3152FET208	192 kB	yes	no	Device/Host/OTG	3	yes	yes	208	-40 °C to +85 °C
LPC3154FET208	192 kB	yes	yes	Device/Host/OTG	3	yes	yes	208	-40 °C to +85 °C

4. Block diagram

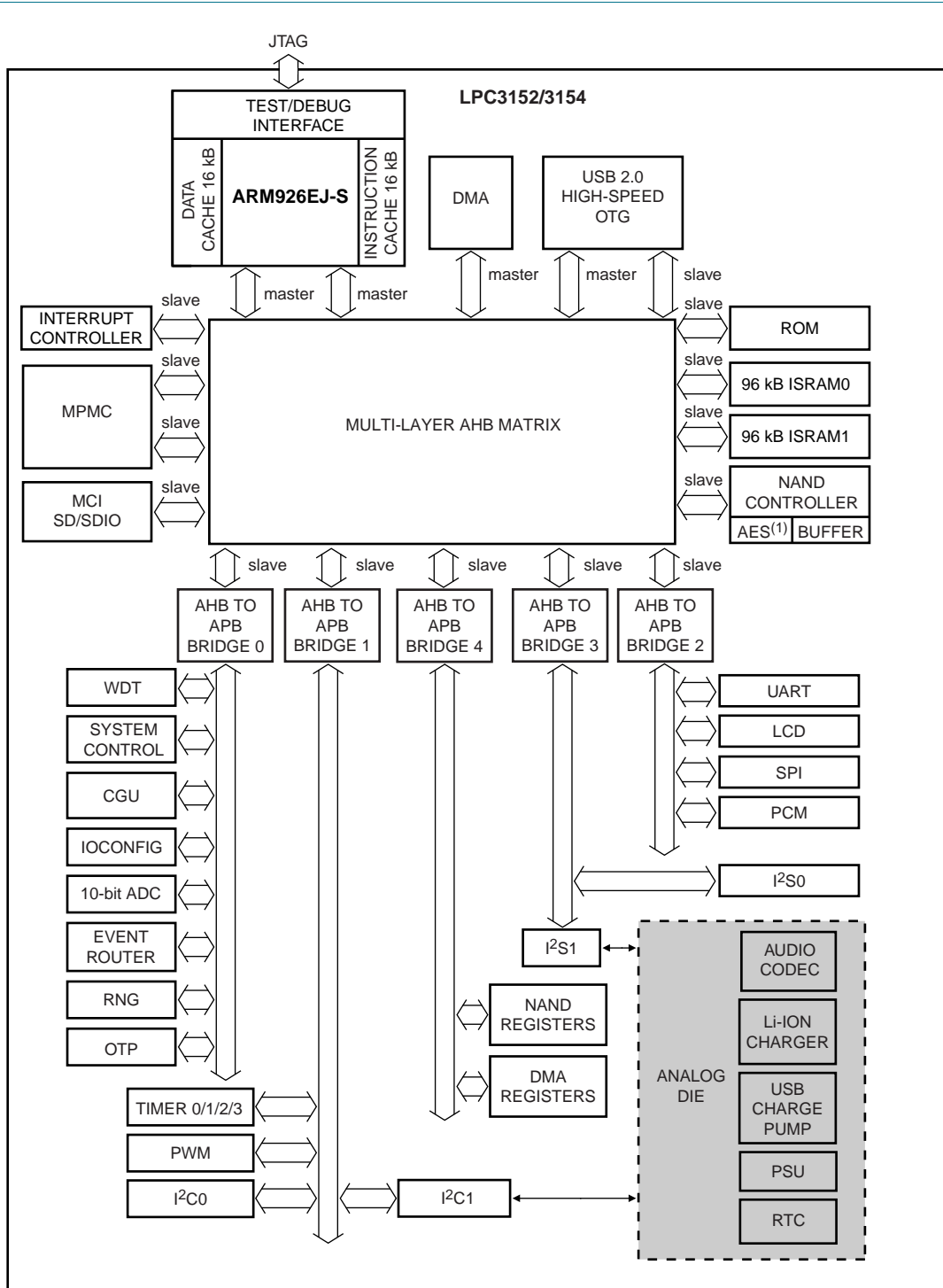

002aae095

(1) AES decryption engine available in LPC3154 only.

Fig 1. LPC3152/3154 block diagram

5. Pinning information

5.1 Pinning

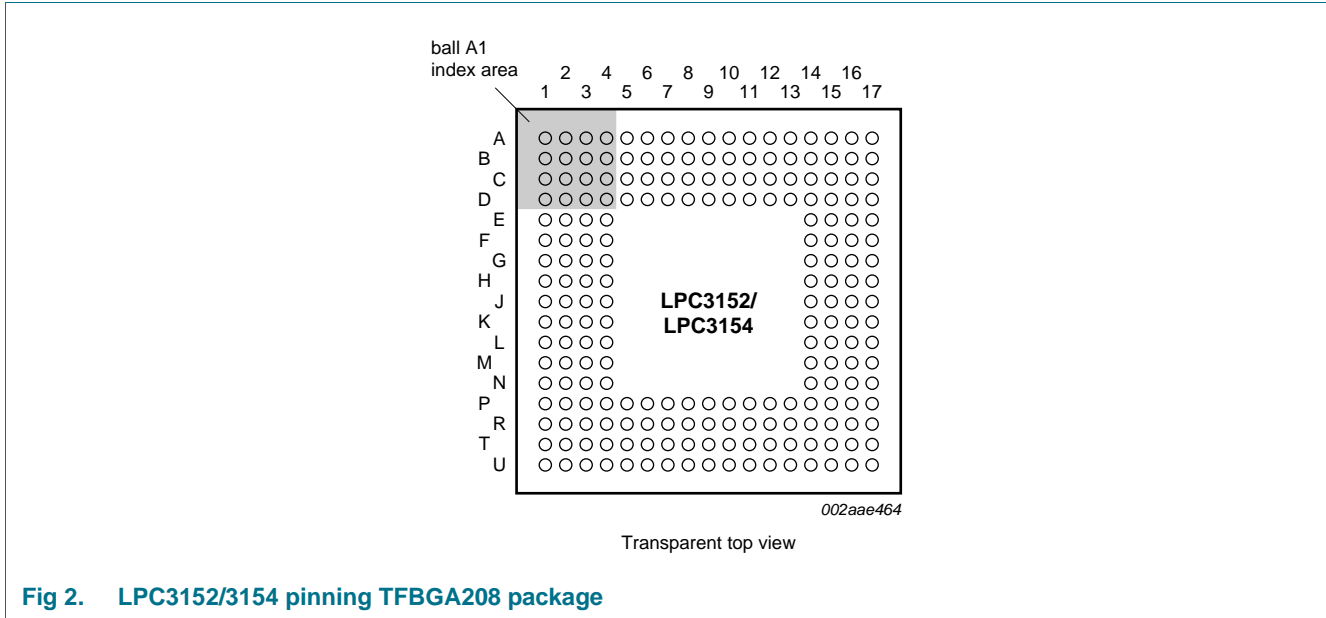

Table 3. Pin allocation table

Pin names with prefix *m* are multiplexed pins. See [Table 11](#) for pin function selection of multiplexed pins.

Pin	Symbol	Pin	Symbol	Pin	Symbol	Pin	Symbol
Row A							
1	n.c.	2	EBI_A_1_CLE	3	EBI_D_9	4	VDDE_IOC
5	VSSE_IOC	6	VDDI	7	VSSI	8	SPI_MISO
9	I2C_SCL0	10	FFAST_IN	11	n.c.	12	n.c.
13	ADC10B_GNDA	14	VSSE_IOC	15	VDDE_IOC	16	HP_VDDA33
17	n.c.	-	-	-	-	-	-
Row B							
1	n.c.	2	n.c.	3	n.c.	4	n.c.
5	mNAND_RYBN0	6	mGPIO9	7	mGPIO6	8	SPI_MOSI
9	n.c.	10	FFAST_OUT	11	VDDA12	12	ADC10B_GPA0
13	ADC10B_VDDA33	14	n.c.	15	HP_FCR	16	HP_GNDA
17	HP_OUTL	-	-	-	-	-	-
Row C							
1	n.c.	2	EBI_D_10	3	n.c.	4	EBI_A_0_ALE
5	mNAND_RYBN1	6	mGPIO10	7	mGPIO7	8	SPI_SCK
9	VPP	10	I2C_SDA0	11	VSSA12	12	ADC10B_GPA2
13	ADC10B_GPA1	14	DAC_VDDA33	15	HP_OUTR	16	HP_FCL
17	PSU_PLAY	-	-	-	-	-	-
Row D							
1	VDDE_IOA	2	EBI_D_11	3	EBI_D_8	4	mNAND_RYBN3

Table 3. Pin allocation table ...continuedPin names with prefix *m* are multiplexed pins. See [Table 11](#) for pin function selection of multiplexed pins.

Pin	Symbol	Pin	Symbol	Pin	Symbol	Pin	Symbol
5	mNAND_RYBN2	6	mGPIO8	7	mGPIO5	8	SPI_CS_OUT0
9	SPI_CS_IN	10	PWM_DATA	11	GPIO4	12	GPIO3
13	n.c.	14	HP_OUTC	15	PSU_STOP	16	PSU_VSSA
17	PSU_VSSA_CLEAN	-	-	-	-	-	-
Row E							
1	VSSE_IOA	2	EBI_D_12	3	EBI_D_7	4	EBI_D_6
14	HP_VREF	15	RSTIN_N	16	PSU_VBAT	17	PSU_VOUT3
Row F							
1	n.c.	2	EBI_D_13	3	EBI_D_5	4	EBI_D_4
14	TDO	15	DAC_VREFN	16	DAC_VREFP	17	PSU_VBAT2
Row G							
1	n.c.	2	EBI_D_14	3	n.c.	4	EBI_D_3
14	PSU_VOUT2	15	VDDE_IOD	16	PSU_VIN1	17	PSU_LX2
Row H							
1	VSSI	2	EBI_D_15	3	EBI_D_1	4	EBI_D_2
14	PSU_VOUT1	15	PSU_LX1	16	PSU_VSS1	17	PSU_VBAT1
Row J							
1	VDDI	2	EBI_NCAS_BLOUT_0	3	EBI_D_0	4	EBI_NRAS_BLOUT_1
14	CHARGE_VBUS	15	CHARGE_VSS	16	PSU_VBUS	17	CHARGE_VNTC
Row K							
1	VSSE_IOB	2	n.c.	3	EBI_DQM_0_NOE	4	EBI_NWE
14	RTC_BACKUP	15	CHARGE_CC_REF	16	CHARGE_VBAT	17	CHARGE_BAT_SENSE
Row L							
1	VDDE_IOB	2	NAND_NCS_0	3	NAND_NCS_1	4	NAND_NCS_2
14	VSSE_IOD	15	RTC_VDD36	16	FSLOW_OUT	17	FSLOW_IN
Row M							
1	VDDE_IOA	2	NAND_NCS_3	3	n.c.	4	CLOCK_OUT
14	VDDI_AD	15	VSSI_AD	16	RTC_INT	17	RTC_VSS
Row N							
1	VSSE_IOA	2	USB_VDDA12_PLL	3	USB_VBUS	4	USB_RREF
14	ADC_VDDA33	15	ADC_VDDA18	16	ADC_GNDA	17	UOS_VSS
Row P							
1	n.c.	2	USB_VSSA_REF	3	USB_ID	4	mLCD_DB_10
5	mLCD_DB_9	6	mLCD_DB_5	7	mLCD_E_RD	8	mLCD_DB_1
9	I2SRX_DATA0	10	UART_TXD	11	mUART_CTS_N	12	GPIO2
13	ADC_TINL	14	ADC_TINR	15	UOS_VBUS	16	UOS_VBAT
17	UOS_CX2	-	-	-	-	-	-
Row R							
1	USB_DM	2	USB_VSSA_TERM	3	USB_VDDA33	4	mLCD_DB_15
5	mLCD_DB_6	6	mLCD_DB_3	7	mLCD_RS	8	mLCD_CSB

Table 3. Pin allocation table ...continuedPin names with prefix *m* are multiplexed pins. See [Table 11](#) for pin function selection of multiplexed pins.

Pin	Symbol	Pin	Symbol	Pin	Symbol	Pin	Symbol
9	I2SRX_WS0	10	UART_RXD	11	mUART_RTS_N	12	mI2STX_WS0
13	GPIO0	14	ADC_VINR	15	ADC_MIC	16	ADC_VREFN
17	UOS_CX1	-	-	-	-	-	-

Row T

1	USB_DP	2	USB_GNDA	3	USB_VDDA33_DRV	4	mLCD_DB_12
5	mLCD_DB_7	6	mLCD_DB_2	7	mLCD_DB_0	8	mLCD_RW_WR
9	I2SRX_BCK0	10	TDI	11	mI2STX_CLK0	12	mI2STX_BCK0
13	mI2STX_DATA0	14	GPIO1	15	ADC_VINL	16	ADC_VREF
17	ADC_VREFFP	-	-	-	-	-	-

Row U

1	n.c.	2	mLCD_DB_14	3	mLCD_DB_13	4	mLCD_DB_11
5	mLCD_DB_8	6	mLCD_DB_4	7	VDDE_IOB	8	VSSE_IOB
9	TMS	10	JTAGSEL	11	TRST_N	12	TCK
13	VDDI	14	VSSI	15	VDDE_IOC	16	VSSE_IOC
17	RTC_CLK32	-	-	-	-	-	-

Table 4. Pin descriptionPin names with prefix *m* are multiplexed pins. See [Table 11](#) for pin function selection of multiplexed pins.

TFBGA pin name	TFB GA ball	Digital I/O level [1]	Application function	Pin state after reset [2]	Cell type [3]	Description
----------------	-------------	---------------------------------------	----------------------	-------------------------------------------	-------------------------------	-------------

Clock generation unit

FFAST_IN	A10	SUP1	AI		AIO2	12 MHz oscillator clock input
FFAST_OUT	B10	SUP1	AO		AIO2	12 MHz oscillator clock output
VDDA12	B11	SUP1	Supply		PS3	12 MHz oscillator/PLLs analog supply
VSSA12	C11	-	Ground		CG1	12 MHz oscillator/PLLs analog ground
RSTIN_N	E15	SUP3	DI	I:PU	DIO2	System reset input (active LOW)
CLOCK_OUT	M4	SUP4	DO	O	DIO4	Clock output

10-bit ADC

ADC10B_VDDA33	B13	SUP3	Supply		PS3	10-bit ADC analog supply
ADC10B_GNDA	A13	-	Ground		CG1	10-bit ADC analog ground
ADC10B_GPA0	B12	SUP3	AI		AIO1	10-bit ADC analog input
ADC10B_GPA1	C13	SUP3	AI		AIO1	10-bit ADC analog input
ADC10B_GPA2	C12	SUP3	AI		AIO1	10-bit ADC analog input

Audio ADC

ADC_MIC	R15	-	AI		AIO2	ADC microphone input
ADC_VINL	T15	-	AI		AIO2	ADC line input left
ADC_VINR	R14	-	AI		AIO2	ADC line input right
ADC_TINL	P13	-	AI		AIO2	ADC tuner input left
ADC_TINR	P14	-	AI		AIO2	ADC tuner input right
ADC_VREF	T16	-	AO		AIO2	ADC reference voltage output

Table 4. Pin description ...continued

Pin names with prefix *m* are multiplexed pins. See [Table 11](#) for pin function selection of multiplexed pins.

TFBGA pin name	TFB GA ball	Digital I/O level [1]	Application function	Pin state after reset [2]	Cell type [3]	Description
ADC_VREFN	R16	-	AI		AIO2	ADC negative reference voltage
ADC_VREFP	T17	-	AI		AIO2	ADC positive reference voltage
ADC_VDDA18	N15	SUP2	Supply		CS1	ADC digital voltage supply
ADC_VDDA33	N14	SUP3	Supply		CS1	ADC analog voltage supply
ADC_GNDA	N16	-	Ground		CG1	ADC analog ground
Audio Stereo DAC						
DAC_VDDA33	C14	SUP3	Supply		CS1	SDAC analog supply
DAC_VREFP	F16	SUP3	AI		AIO2	SDAC positive reference voltage
DAC_VREFN	F15	-	AI		AIO2	SDAC negative reference voltage
Class AB amplifier						
HP_OUTC	D14	-	AO		AIO2	Headphone common output reference for Class AB
HP_FCL	C16	-	AI		AIO2	Headphone filter capacitor left
HP_FCR	B15	-	AI		AIO2	Headphone filter capacitor right
HP_VREF	E14	-	AI		AIO2	Analog reference supply for headphone and DAC
HP_OUTL	B17	-	AO		AIO2	Headphone left output
HP_OUTR	C15	-	AO		AIO2	Headphone right output
HP_VDDA33	A16	SUP3	Supply		CS1	Headphone analog supply Class AB
HP_GNDA	B16	-	Ground		CG1	Headphone analog ground
USB HS 2.0 OTG						
USB_VBUS	N3	SUP5	AI		AIO3	USB supply detection line
USB_ID	P3	SUP3	AI		AIO1	Indicates to the USB transceiver whether in device (USB_ID HIGH) or host (USB_ID LOW) mode (contains internal pull-up resistor)
USB_RREF	N4	SUP3	AIO		AIO1	USB connection for external reference resistor (12 kΩ +/- 1%) to analog ground supply
USB_DP	T1	SUP3	AIO		AIO1	USB D+ connection with integrated 45 Ω termination resistor
USB_DM	R1	SUP3	AIO		AIO1	USB D- connection with integrated 45 Ω termination resistor
USB_VDDA12_PLL	N2	SUP1	Supply		PS3	USB PLL supply
USB_VDDA33_DRV	T3	SUP3	Supply		PS3	USB analog supply for driver
USB_VDDA33	R3	SUP3	Supply		PS3	USB analog supply for PHY
USB_VSSA_TERM	R2	-	Ground		CG1	USB analog ground for clean reference for on chip termination resistors
USB_GNDA	T2	-	Ground		CG1	USB analog ground
USB_VSSA_REF	P2	-	Ground		CG1	USB analog ground for clean reference

Table 4. Pin description ...continuedPin names with prefix *m* are multiplexed pins. See [Table 11](#) for pin function selection of multiplexed pins.

TFBGA pin name	TFBGA ball	Digital I/O level [1]	Application function	Pin state after reset [2]	Cell type [3]	Description
JTAG						
JTAGSEL	U10	SUP3	DI / GPIO	I:PD	DIO1	JTAG selection. Controls which digital die TAP controller is configured in the JTAG chain along with the analog die TAP controller. Must be LOW during power-on reset.
TDI	T10	SUP3	DI / GPIO	I:PU	DIO1	JTAG data Input
TRST_N	U11	SUP3	DI / GPIO	I:PD	DIO1	JTAG TAP Controller Reset Input. Must be LOW during power-on reset.
TCK	U12	SUP3	DI / GPIO	I:PD	DIO1	JTAG clock input
TMS	U9	SUP3	DI / GPIO	I:PU	DIO1	JTAG mode select input
TDO	F14	SUP3	DO	Z	DIO2	JTAG data output
UART						
mUART_CTS_N [4][6]	P11	SUP3	DI / GPIO	I	DIO1	UART Clear-To-Send (CTS) (active LOW)
mUART_RTS_N [4][6]	R11	SUP3	DO / GPIO	O	DIO1	UART Ready-To-Send (RTS) (active LOW)
UART_RXD [4]	R10	SUP3	DI / GPIO	I	DIO1	UART serial input
UART_TXD [4]	P10	SUP3	DO / GPIO	O	DIO1	UART serial output
I²C master/slave interface						
I2C_SDA0	C10	SUP3	DIO	I	IICD	I ² C-bus data line
I2C_SCL0	A9	SUP3	DIO	I	IICC	I ² C-bus clock line
Serial Peripheral Interface (SPI)						
SPI_CS_OUT0 [4]	D8	SUP3	DO	O	DIO4	SPI chip select output (master)
SPI_SCK [4]	C8	SUP3	DIO	I	DIO4	SPI clock input (slave) / clock output (master)
SPI_MISO [4]	A8	SUP3	DIO	I	DIO4	SPI data input (master) / data output (slave)
SPI_MOSI [4]	B8	SUP3	DIO	I	DIO4	SPI data output (master) / data input (slave)
SPI_CS_IN [4]	D9	SUP3	DI	I	DIO4	SPI chip select input (slave)
Digital power supply						
VDDI	J1; U13; A6	SUP1	Supply		CS2	Digital core supply
VDDI_AD	M14	SUP2	Supply		CS2	Core supply for digital logic on analog die - has to be connected to 1.4/1.8 V rail
VSSI	H1; U14; A7	-	Ground		CG2	Digital core ground
VSSI_AD	M15	-	Ground		CG2	Digital core ground of analog die
Peripheral power supply						
VDDE_IOA	D1; M1	SUP4	Supply		PS1	Peripheral supply NAND flash controller
VDDE_IOB	L1; U7	SUP8	Supply		PS1	Peripheral supply LCD interface / SDRAM interface

Table 4. Pin description ...continuedPin names with prefix *m* are multiplexed pins. See [Table 11](#) for pin function selection of multiplexed pins.

TFBGA pin name	TFB GA ball	Digital I/O level [1]	Application function	Pin state after reset [2]	Cell type [3]	Description
VDDE_IOC	U15; A15; A4;	SUP3	Supply		PS1	Peripheral supply
VDDE_IOD	G15	SUP3	Supply		PS2	Analog die peripheral supply
VSSE_IOA	E1; N1	-	Ground		PG1	Peripheral ground NAND flash controller
VSSE_IOB	K1; U8	-	Ground		PG1	Peripheral ground LCD interface / SDRAM interface
VSSE_IOC	U16; A14; A5;	-	Ground		PG1	Peripheral ground
VSSE_IOD	L14	-	Ground		PG2	Analog die peripheral ground
LCD interface						
mLCD_CS[4]	R8	SUP8	DO	O	DIO4	LCD chip select (active LOW)
mLCD_E_RD[4]	P7	SUP8	DO	O	DIO4	LCD: 6800 enable, 8080 read enable (active HIGH)
mLCD_RS[4]	R7	SUP8	DO	O	DIO4	LCD: instruction register (LOW)/ data register (HIGH) select
mLCD_RW_WR[4]	T8	SUP8	DO	O	DIO4	LCD: 6800 read/write select, 8080 write enable (active HIGH)
mLCD_DB_0[4]	T7	SUP8	DIO	O	DIO4	LCD Data 0
mLCD_DB_1[4]	P8	SUP8	DIO	O	DIO4	LCD Data 1
mLCD_DB_2[4]	T6	SUP8	DIO	O	DIO4	LCD Data 2
mLCD_DB_3[4]	R6	SUP8	DIO	O	DIO4	LCD Data 3
mLCD_DB_4[4]	U6	SUP8	DIO	O	DIO4	LCD Data 4
mLCD_DB_5[4]	P6	SUP8	DIO	O	DIO4	LCD Data 5
mLCD_DB_6[4]	R5	SUP8	DIO	O	DIO4	LCD Data 6
mLCD_DB_7[4]	T5	SUP8	DIO	O	DIO4	LCD Data 7
mLCD_DB_8[4]	U5	SUP8	DIO	O	DIO4	LCD Data 8 / 8-bit Data 0
mLCD_DB_9[4]	P5	SUP8	DIO	O	DIO4	LCD Data 9 / 8-bit Data 1
mLCD_DB_10[4]	P4	SUP8	DIO	O	DIO4	LCD Data 10 / 8-bit Data 2
mLCD_DB_11[4]	U4	SUP8	DIO	O	DIO4	LCD Data 11 / 8-bit Data 3
mLCD_DB_12[4]	T4	SUP8	DIO	O	DIO4	LCD Data 12 / 8-bit Data 4 / 4-bit Data 0
mLCD_DB_13[4]	U3	SUP8	DIO	O	DIO4	LCD Data 13 / 8-bit Data 5 / 4-bit Data 1 / serial clock output
mLCD_DB_14[4]	U2	SUP8	DIO	O	DIO4	LCD Data 14 / 8-bit Data 6 / 4-bit Data 2 / serial data input
mLCD_DB_15[4]	R4	SUP8	DIO	O	DIO4	LCD Data 15 / 8-bit Data 7 / 4-bit Data 3 / serial data output
I²S/Digital audio input						
I2SRX_DATA0[4]	P9	SUP3	DI / GPIO	I	DIO1	I ² S input serial data receive

Table 4. Pin description ...continued

Pin names with prefix *m* are multiplexed pins. See [Table 11](#) for pin function selection of multiplexed pins.

TFBGA pin name	TFB GA ball	Digital I/O level [1]	Application function	Pin state after reset [2]	Cell type [3]	Description
I2SRX_BCK0[4]	T9	SUP3	DIO / GPIO	I	DIO1	I ² S input bitclock
I2SRX_WS0[4]	R9	SUP3	DIO / GPIO	I	DIO1	I ² S input word select
I²S/Digital audio output						
mI2STX_DATA0[4]	T13	SUP3	DO / GPIO	O	DIO1	I ² S output serial data out
mI2STX_BCK0[4]	T12	SUP3	DO / GPIO	O	DIO1	I ² S output bitclock
mI2STX_WS0[4]	R12	SUP3	DO / GPIO	O	DIO1	I ² S output word select
mI2STX_CLK0[4]	T11	SUP3	DO / GPIO	O	DIO1	I ² S output serial clock
General Purpose IO (IOCONFIG module)						
GPIO0[8]	R13	SUP3	GPIO	I:PD	DIO1	General Purpose IO pin 0 (mode pin 0)
GPIO1[8]	T14	SUP3	GPIO	I:PD	DIO1	General Purpose IO pin 1 (mode pin 1)
GPIO2[8]	P12	SUP3	GPIO	I	DIO1	General Purpose IO pin 2 (mode pin 2/blinking LED)
GPIO3	D12	SUP3	GPIO	I	DIO1	General Purpose IO pin 3 (connect to PSU_STOP)[5]
GPIO4	D11	SUP3	GPI	I	DIO1	General Purpose Input pin 4
mGPIO5[4]	D7	SUP3	GPIO	I	DIO4	General Purpose IO pin 5
mGPIO6[4]	B7	SUP3	GPIO	I	DIO4	General Purpose IO pin 6
mGPIO7[4]	C7	SUP3	GPIO	I	DIO4	General Purpose IO pin 7
mGPIO8[4]	D6	SUP3	GPIO	I	DIO4	General Purpose IO pin 8
mGPIO9[4]	B6	SUP3	GPIO	I	DIO4	General Purpose IO pin 9
mGPIO10[4]	C6	SUP3	GPIO	I	DIO4	General Purpose IO pin 10
External Bus Interface (NAND flash controller)						
EBI_A_0_ALE[4]	C4	SUP4	DO	O	DIO4	EBI Address Latch Enable (ALE)
EBI_A_1_CLE[4]	A2	SUP4	DO	O	DIO4	EBI Command Latch Enable (CLE)
EBI_D_0[4]	J3	SUP4	DIO	I	DIO4	EBI Data I/O 0
EBI_D_1[4]	H3	SUP4	DIO	I	DIO4	EBI Data I/O 1
EBI_D_2[4]	H4	SUP4	DIO	I	DIO4	EBI Data I/O 2
EBI_D_3[4]	G4	SUP4	DIO	I	DIO4	EBI Data I/O 3
EBI_D_4[4]	F4	SUP4	DIO	I	DIO4	EBI Data I/O 4
EBI_D_5[4]	F3	SUP4	DIO	I	DIO4	EBI Data I/O 5
EBI_D_6[4]	E4	SUP4	DIO	I	DIO4	EBI Data I/O 6
EBI_D_7[4]	E3	SUP4	DIO	I	DIO4	EBI Data I/O 7
EBI_D_8[4]	D3	SUP4	DIO	I	DIO4	EBI Data I/O 8
EBI_D_9[4]	A3	SUP4	DIO	I	DIO4	EBI Data I/O 9
EBI_D_10[4]	C2	SUP4	DIO	I	DIO4	EBI Data I/O 10
EBI_D_11[4]	D2	SUP4	DIO	I	DIO4	EBI Data I/O 11
EBI_D_12[4]	E2	SUP4	DIO	I	DIO4	EBI Data I/O 12
EBI_D_13[4]	F2	SUP4	DIO	I	DIO4	EBI Data I/O 13

Table 4. Pin description ...continued

Pin names with prefix *m* are multiplexed pins. See [Table 11](#) for pin function selection of multiplexed pins.

TFBGA pin name	TFB GA ball	Digital I/O level [1]	Application function	Pin state after reset [2]	Cell type [3]	Description
EBI_D_14 [4]	G2	SUP4	DIO	I	DIO4	EBI Data I/O 14
EBI_D_15 [4]	H2	SUP4	DIO	I	DIO4	EBI Data I/O 15
EBI_DQM_0_NOE [4]	K3	SUP4	DO	O	DIO4	EBI read enable (active LOW)
EBI_NWE [4]	K4	SUP4	DO	O	DIO4	EBI write enable (active LOW)
NAND_NCS_0 [4]	L2	SUP4	DO	O	DIO4	EBI chip enable 0
NAND_NCS_1 [4]	L3	SUP4	DO	O	DIO4	EBI chip enable 1
NAND_NCS_2 [4]	L4	SUP4	DO	O	DIO4	EBI chip enable 2
NAND_NCS_3 [4]	M2	SUP4	DO	O	DIO4	EBI chip enable 3
mNAND_RYBN0 [4]	B5	SUP4	DI	I	DIO4	EBI NAND ready/busy 0
mNAND_RYBN1 [4]	C5	SUP4	DI	I	DIO4	EBI NAND ready/busy 1
mNAND_RYBN2 [4]	D5	SUP4	DI	I	DIO4	EBI NAND ready/busy 2
mNAND_RYBN3 [4]	D4	SUP4	DI	I	DIO4	EBI NAND ready/busy 3
EBI_NCAS_BLOUT_0 [4]	J2	SUP4	DO	O	DIO4	EBI lower lane byte select (7:0)
EBI_NRAS_BLOUT_1 [4]	J4	SUP4	DO	O	DIO4	EBI upper lane byte select (15:8)

Secure one time programmable memory

VPP [7]	C9	SUP1/ SUP3	Supply		PS3	Supply for polyfuse programming
---------	----	---------------	--------	--	-----	---------------------------------

Real Time Clock (RTC)

RTC_VDD36	L15	SUP6	Supply		CS1	RTC supply connected to battery
RTC_VSS	M17	-	Ground		CG1	RTC ground
FSLOW_OUT	L16	SUP7	AO		AIO2	RTC 32.768 kHz clock output
FSLOW_IN	L17	SUP7	AI		AIO2	RTC 32.768 kHz clock input
RTC_INT	M16	SUP6	DO	O	AIO2	RTC interrupt (HIGH active)
RTC_BACKUP	K14	SUP7	Supply		CS1	RTC backup capacitor connection
RTC_CLK32	U17	SUP6	AO	O	AIO2	RTC 32 kHz clock output for on-board applications such as tuner

Power supply unit

PSU_VBUS	J16	SUP5	Supply		CS1	PSU USB supply voltage
PSU_VOUT1	H14	SUP3	AO		CS1	PSU output1
PSU_LX1	H15	-	AIO		CS1	PSU external coil terminal for output1
PSU_LX2	G17	-	AIO		CS1	PSU external coil terminal for output2
PSU_VSS1	H16	-	Ground		CG1	PSU ground
PSU_VIN1	G16	-	AI		CS1	PSU output1 input voltage
PSU_VOUT2	G14	SUP1	AO		CS1	PSU output2
PSU_VOUT3	E17	SUP2	AO		CS1	PSU output3
PSU_VSSA	D16	-	Ground		CG1	PSU ground
PSU_VSSA_CLEAN	D17	-	Ground		CG1	PSU reference circuit ground
PSU_PLAY	C17	SUP3	AI	I	AIO2	PSU play button input (active HIGH)

Table 4. Pin description ...continued

Pin names with prefix *m* are multiplexed pins. See [Table 11](#) for pin function selection of multiplexed pins.

TFBGA pin name	TFB GA ball	Digital I/O level [1]	Application function	Pin state after reset [2]	Cell type [3]	Description
PSU_STOP	D15	SUP3	AIO	I	AIO2	PSU stop signal input (active HIGH)
PSU_VBAT1	H17	SUP6	Supply		CS1	PSU DCDC1 supply input
PSU_VBAT2	F17	SUP6	Supply		CS1	PSU DCDC2 supply input
PSU_VBAT	E16	SUP6	Supply		CS1	PSU Li-ion battery input
Li-Ion charger						
CHARGE_VNTC	J17	-	AI		AIO2	Charger NTC connection
CHARGE_VSS	J15	-	Ground		CG1	Charger ground Li-Ion
CHARGE_CC_REF	K15	-	AO		CS1	Charger constant current reference
CHARGE_VBUS	J14	SUP5	Supply		CS1	Charger 5 V supply
CHARGE_BAT_SENSE	K17	-	AI		AIO2	Charger battery sense terminal
CHARGE_VBAT	K16	SUP6	AO		CS1	Charger positive battery terminal connection
USB charge pump (host mode)						
UOS_VSS	N17	-	Ground		CG1	USB charge pump ground
UOS_VBUS	P15	SUP5	AO		CS1	USB charge pump output to USB_VBUS
UOS_VBAT	P16	SUP6	Supply		CS1	USB charge-pump supply Li-ion battery input
UOS_CX2	P17	-	AIO		CS1	USB charge-pump capacitor terminal for voltage converter
UOS_CX1	R17	-	AIO		CS1	USB charge-pump capacitor terminal for voltage converter
Pulse Width Modulation module						
PWM_DATA [4]	D10	SUP3	DO/GPIO	O	DIO1	PWM output

[1] Digital IO levels are explained in [Table 5](#).

[2] I = input; I:PU = input with internal weak pull-up; I:PD = input with internal weak pull-down; O = output.

[3] Cell types are explained in [Table 6](#).

[4] Pin can be configured as GPIO pin in the IOCONFIG block.

[5] GPIO3 is driven HIGH if the boot process fails. It is recommended to connect GPIO3 to PSU_STOP, so that the LPC3152/3154 will be powered down and further access prevented if the boot ROM detects an error.

[6] The UART flow control lines (mUART_CTS_N and mUART_RTS_N) are multiplexed. This means that if these balls are not required for UART flow control, they can be selected to be used for their alternative function: SPI chip select signals (SPI_CS_OUT1 and SPI_CS_OUT2).

[7] The polyfuses get unintentionally burned at random if VPP is powered to 2.3 V or greater before the VDDI is powered up to minimum nominal voltage. This will destroy the sample, and it can be locked (security) and the AES key can be corrupted. For this reason it is recommended that VPP be powered by SUP1 at power-on.

[8] To ensure that GPIO0, GPIO1 and GPIO2 pins come up as inputs, pins TRST_N and JTAGSEL must be LOW at power-on reset, see [UM10315 JTAG chapter](#) for details.

Table 5: Supply domains

Supply domain	Voltage range	Related supply pins	Description
SUP1	1.0 V to 1.3 V	VDDI, VDDA12, USB_VDDA12_PLL, VPP (read)	Digital core supply
SUP2	1.4 V or 1.8 V	VDDI_AD, ADC_VDDA18	Digital core supply for the analog die functions
SUP3	2.7 V to 3.6 V	VDDE_IOC, VDDE_IOD, ADC10B_VDDA33, ADC_VDDA33, DAC_VDDA33, HP_VDDA33, USB_VDDA33_DRV, USB_VDDA33, VPP (write)	Peripheral supply
SUP4	1.65 V to 1.95 V (in 1.8 V mode) 2.5 V to 3.6 V (in 3.3 V mode)	VDDE_IOA	Peripheral supply for NAND flash interface
SUP5	4.5 V to 5.5 V	PSU_VBUS, CHARGE_VBUS, UOS_VBUS, USB_VBUS	USB VBUS voltage
SUP6	3.2 V to 4.2 V	RTC_VDD36, PSU_VBAT1, PSU_VBAT2, PSU_VBAT	Li-ion battery voltage
SUP7	1.8 V	RTC_BACKUP	Real-time clock voltage domain (generated internally from SUP6)
SUP8	1.65 V to 1.95 V (in 1.8 V mode) 2.5 V to 3.6 V (in 3.3 V mode)	VDDE_IOB	Peripheral supply for SDRAM/SRAM/bus-based LCD [1]

[1] When the SDRAM is used, the supply voltage of the NAND flash, SDRAM, and the LCD interface must be the same, i.e. SUP4 and SUP8 should be connected to the same rail. (See also [Section 6.28.3](#).)

Table 6: Cell types

I/O pad name	Type	Function	Description
DIO1	bspts3chp	Digital input/output	Bidirectional 3.3 V; 3-state output; 3 ns slew rate control; plain input; CMOS with hysteresis; programmable pull-up, pull-down, repeater.
DIO2	bpts5pcph	Digital input/output	Bidirectional 5 V; plain input; 3-state output; CMOS with programmable hysteresis; programmable pull-up, pull-down, repeater.
DIO3	bpts5pcph1v8	Digital input/output	Bidirectional 1.8 V; plain input; 3-state output; CMOS with programmable hysteresis; programmable pull-up, pull-down, repeater.
DIO4	mem1 bsptz40pchp	Digital input/output	Bidirectional 1.8 or 3.3 V; plain input; 3-state output; CMOS with programmable hysteresis; programmable pull-up, pull-down, repeater.
IICC	iic3m4scl	Digital input/output	I ² C-bus; clock signal; cell based ESD protection.
IICD	iic3mvsda	Digital input/output	I ² C-bus; data signal; cell based ESD protection.
AIO1	apio3v3	Analog input/output	Analog cell; analog input/output; protection to external 3.3 V supply rail.
AIO2	apio	Analog input/output	Analog pad; analog input/output.
AIO3	apiot5v	Analog input/output	Analog cell; analog input/output; 5 V tolerant pad-based ESD protection.
CS1	vddco	Core supply	-
CS2	vddi	Core supply	-

Table 6: Cell types

I/O pad name	Type	Function	Description
PS1	vdde3v3	Peripheral supply	-
PS2	vdde	Peripheral supply	-
CG1	vssco	Core ground	-
CG2	vssis	Core ground	-
PG1	vsse	Peripheral ground	-

6. Functional description

6.1 ARM926EJ-S

The processor embedded in the chip is the ARM926EJ-S. It is a member of the ARM9 family of general-purpose microprocessors. The ARM926EJ-S is intended for multi-tasking applications where full memory management, high performance, and low power are important.

This module has the following features:

- ARM926EJ-S processor core which uses a five-stage pipeline consisting of fetch, decode, execute, memory and write stages. The processor supports both the 32-bit ARM and 16-bit Thumb instruction sets, which allows a trade off between high performance and high code density. The ARM926EJ-S also executes an extended ARMv5TE instruction set which includes support for Java byte code execution.
- Contains an AMBA BIU for both data accesses and instruction fetches.
- Memory Management Unit (MMU).
- 16 kB instruction and 16 kB data separate cache memories with an 8 word line length. The caches are organized using Harvard architecture.
- Little Endian is supported.
- The ARM926EJ-S processor supports the ARM debug architecture and includes logic to assist in both hardware and software debugging.
- Supports dynamic clock gating for power reduction.
- The processor core clock can be set equal to the AHB bus clock or to an integer number times the AHB bus clock. The processor can be switched dynamically between these settings.
- ARM stall support.

6.2 Memory map

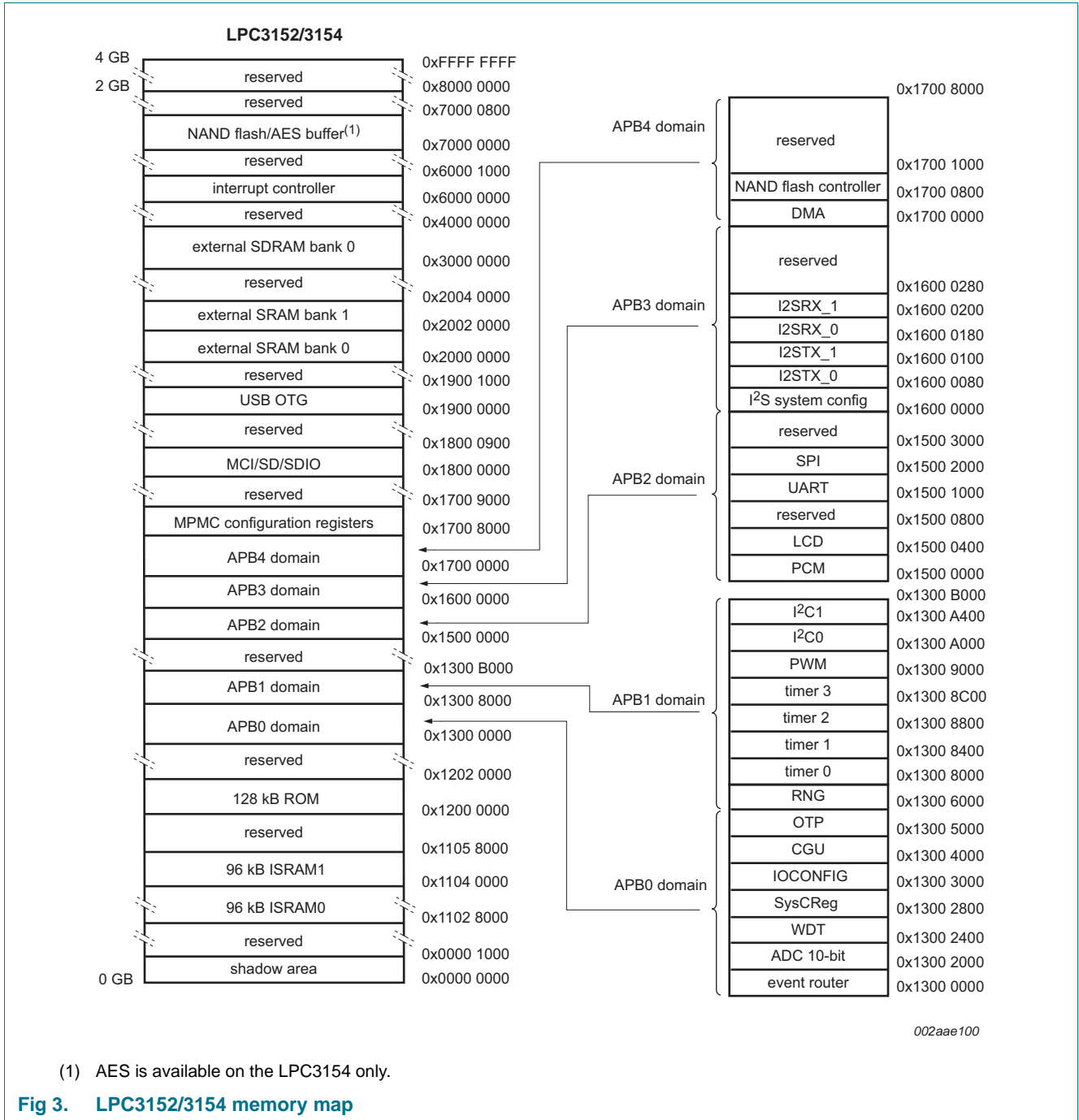

6.2.1 Analog die memory organization

The blocks on the analog die (Audio codec, RTC, Li-ion charger, and Power Supply Unit (PSU)) and their registers are accessed through the I²C1-bus interface as a single slave device with device address 0x0C using the following register addresses:

Table 7. Analog die register addresses (I²C1 slave device address 0x0C)

Block	Address offset
PSU/Li-ion charger	0x0000 - 0x000F
Audio codec	0x0010 - 0x001F
RTC	0x0020 - 0x002F

6.3 JTAG

The JTAG interface allows the incorporation of the LPC3152/3154 in a JTAG scan chain.

This module has the following features:

- ARM926 debug access
- Boundary scan
- The ARM926 debug access can be permanently disabled through the JTAG security bits in the One-Time Programmable memory (OTP) block.

6.4 NAND flash controller

The NAND flash controller is used as a dedicated interface to NAND flash devices.

[Figure 4](#) shows a block diagram of the NAND flash controller module. The heart of the module is formed by a controller block that controls the flow of data from/to the AHB bus through the NAND flash controller block to/from the (external) NAND flash. An error correction encoder/decoder module allows for hardware error correction for support of Multi-Level Cell (MLC) NAND flash devices. In the LPC3154, the NAND flash controller is connected to the AES block to support secure (encrypted) code execution (see [Section 6.21](#)).

Before data is written from the buffer to the NAND flash, optionally it is first protected by an error correction code generated by the ECC module. After data is read from the NAND flash, the error correction module corrects errors, and/or the AES decryption module can decrypt data.

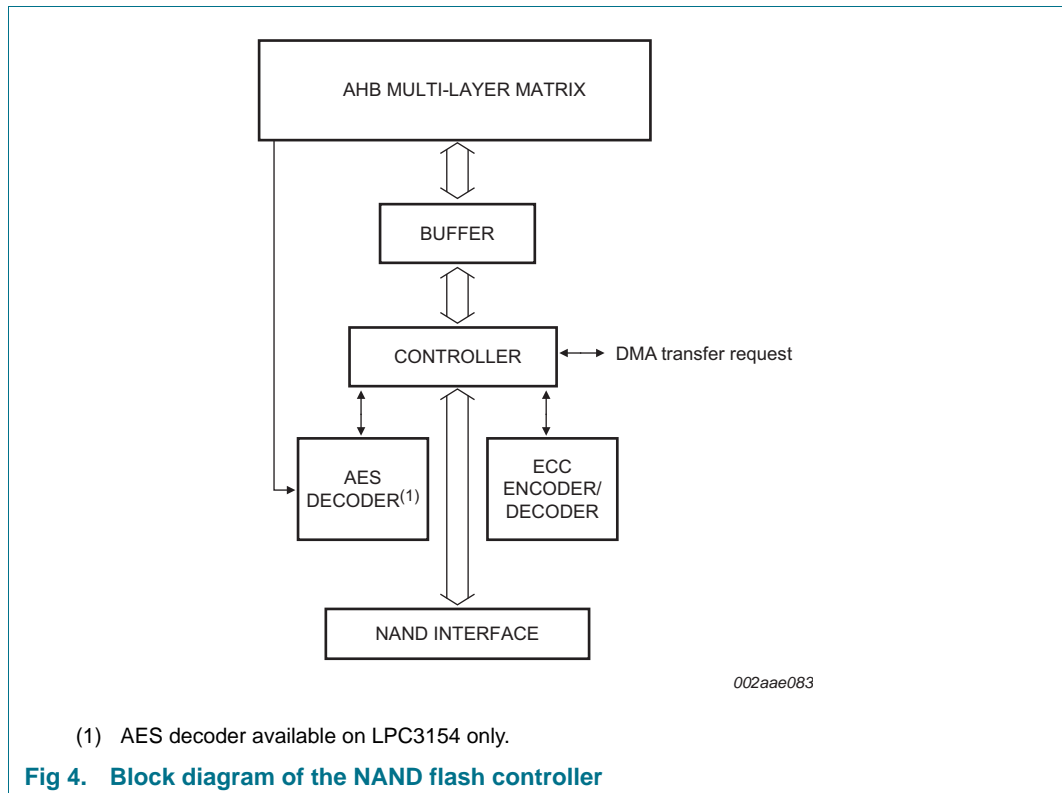

This module has the following features:

- Dedicated NAND flash interface with hardware controlled read and write accesses.
- Wear leveling support with 516-byte mode.
- Software controlled command and address transfers to support wide range of flash devices.
- Software control mode where the ARM is directly master of the flash device.
- Support for 8-bit and 16-bit flash devices.
- Support for any page size from 0.5 kB upwards.
- Programmable NAND flash timing parameters.
- Support for up to four NAND devices.
- Hardware AES decryption (LPC3154 only).
- Error Correction Module (ECC) for MLC NAND flash support:
 - Reed-Solomon error correction encoding and decoding.
 - Uses Reed-Solomon code words with 9-bit symbols over $GF(2^9)$, a total code word length of 469 symbols, including 10 parity symbols, giving a minimum Hamming distance of 11.
 - Up to 8 symbol errors can be corrected per codeword.
 - Error correction can be turned on and off to match the demands of the application.
 - Parity generator for error correction encoding.
 - Wear leveling information can be integrated into protected data.

- Interrupts generated after completion of error correction task with three interrupt registers.
- Error correction statistics distributed to ARM using interrupt scheme.
- Interface is compatible with the ARM External Bus Interface (EBI).

6.5 Multi-Port Memory Controller (MPMC)

The multi-port memory controller supports the interface to different memory types, for example:

- SDRAM
- Low-power SDRAM
- Static memory interface

This module has the following features:

- Dynamic memory interface support including SDRAM, JEDEC low-power SDRAM.
- Address line supporting up to 128 MB (two 64Mx8 devices connected to a single chip select) of dynamic memory.
- The MPMC has two AHB interfaces:
 - a. an interface for accessing external memory.
 - b. a separate control interface to program the MPMC. This enables the MPMC registers to be situated in memory with other system peripheral registers.
- Low transaction latency.
- Read and write buffers to reduce latency and to improve performance, particularly for un-cached processors.
- Static memory features include:
 - asynchronous page mode read
 - programmable wait states
 - bus turnaround delay
 - output enable, and write enable delays
 - extended wait
- One chip select for synchronous memory and two chip selects for static memory devices.
- Power-saving modes.
- Dynamic memory self-refresh mode supported.
- Controller support for 2 k, 4 k, and 8 k row address synchronous memory parts.
- Support for all AHB burst types.
- Little and big-endian support.
- Support for the External Bus Interface (EBI) that enables the memory controller pads to be shared.

6.6 External Bus Interface (EBI)

The EBI module acts as multiplexer with arbitration between the NAND flash and the SDRAM/SRAM memory modules connected externally through the MPMC.

The main purpose for using the EBI module is to save external pins. However only data and address pins are multiplexed. Control signals towards and from the external memory devices are not multiplexed.

Table 8. Memory map of the external SRAM/SDRAM memory modules

Module	Maximum address space		Data width	Device size
External SRAM0	0x2000 0000	0x2000 FFFF	8 bit	64 kB
	0x2000 0000	0x2001 FFFF	16 bit	128 kB
External SRAM1	0x2002 0000	0x2002 FFFF	8 bit	64 kB
	0x2002 0000	0x2003 FFFF	16 bit	128 kB
External SDRAM0	0x3000 0000	0x37FF FFFF	16 bit	128 MB

6.7 Internal ROM Memory

The internal ROM memory is used to store the boot code of the LPC3152/3154. After a reset, the ARM processor will start its code execution from this memory.

The LPC3154 ROM memory has the following features:

- Supports secure booting from SPI flash, NAND flash, SD/SDHC/MMC cards, UART, and USB (DFU class) interfaces.
- Supports SHA1 hash checking on the boot image.
- Supports un-secure boot from UART and USB (DFU class) interfaces during development. Once the AES key is programmed in the OTP, only secure boot is allowed through UART and USB.
- Supports secure booting from managed NAND devices such as moviNAND, iNAND, eMMC-NAND and eSD-NAND using SD/MMC boot mode.
- Contains pre-defined MMU table (16 kB) for simple systems.

The LPC3152 ROM memory has the following features:

- Supports non-secure booting from SPI flash, NAND flash, SD/SDHC/MMC cards, UART, and USB (DFU class) interfaces.
- Supports option to perform CRC32 checking on the boot image.
- Supports non-secure booting from UART and USB (DFU class) interfaces during development.
- Supports non-secure booting from managed NAND devices such as moviNAND, iNAND, eMMC-NAND and eSD-NAND using SD/MMC boot mode.
- Contains pre-defined MMU table (16 kB) for simple systems.

The boot ROM determines the boot mode based on the reset state of the GPIO0, GPIO1, and GPIO2 pins. To ensure that GPIO0, GPIO1 and GPIO2 pins come up as inputs, pins TRST_N and JTAGSEL must be low during power-on reset, see *UM10315 JTAG chapter* for details.

[Table 9](#) shows the various boot modes supported on the LPC3152/3154. If the boot process fails (e.g. due to tampering with security), the boot code drives pin GPIO3 HIGH. It is recommended to connect the GPIO3 pin to PSU_STOP, so that the LPC3152/3154 will be powered down and further access prevented when the boot ROM detects an error.

Table 9. LPC3152/3154 boot modes

Boot mode	GPIO0	GPIO1	GPIO2	Description
NAND	0	0	0	Boots from NAND flash. If proper image is not found, boot ROM will switch to DFU boot mode.
SPI	0	0	1	Boot from SPI NOR flash connected to SPI_CS_OUT0. If proper image is not found, boot ROM will switch to DFU boot mode.
DFU	0	1	0	Device boots via USB using DFU class specification.
SD/MMC	0	1	1	Boot ROM searches all the partitions on the SD/MMC/SDHC/MMC+/eMMC/eSD card for boot image. If partition table is missing, it will start searching from sector 0. A valid image is said to be found if a valid image header is found, followed by a valid image. If a proper image is not found, boot ROM will switch to DFU boot mode.
Reserved 0	1	0	0	Reserved for testing.
NOR flash	1	0	1	Boot from parallel NOR flash connected to EBI_NSTCS_1. [1]
UART	1	1	0	Boot ROM tries to download boot image from UART ((115200 – 8 – n – 1) assuming 12 MHz FFAST clock).
Test	1	1	1	Boot ROM is testing ISRAM using memory pattern test and basic functionality of the analog audio block. Switches to UART boot mode on receiving three ASCII dots ("...") on UART.

[1] For security reasons this mode is disabled when JTAG security feature is used.

6.8 Internal RAM memory

The ISRAM (Internal Static Memory Controller) module is used as controller between the AHB bus and the internal RAM memory. The internal RAM memory can be used as working memory for the ARM processor and as temporary storage to execute the code that is loaded by boot ROM from external devices such as SPI-flash, NAND flash and SD/MMC cards.

This module has the following features:

- Capacity of 192 kB
- Implemented as two independent 96 kB memory banks

6.9 Memory Card Interface (MCI)

The MCI controller interface can be used to access memory cards according to the Secure Digital (SD) and Multi-Media Card (MMC) standards. The host controller can be used to interface to small form factor expansion cards compliant to the SDIO card standard as well. Finally, the MCI supports CE-ATA 1.1 compliant hard disk drives.

This module has the following features:

- One 8-bit wide interface.
- Supports high-speed SD, versions 1.01, 1.10 and 2.0.
- Supports SDIO version 1.10.
- Supports MMCplus, MMCmobile, and MMCmicro cards based on MMC 4.1.
- Supports SDHC memory cards.
- CRC generation and checking.
- Supports 1/4-bit SD cards.
- Card detection and write protection.
- FIFO buffers of 16 bytes deep.
- Host pull-up control.
- SDIO suspend and resume.
- 1-byte to 65 535-byte blocks.
- Suspend and resume operations.
- SDIO Read-wait.
- Maximum clock speed of 52 MHz (MMC 4.1).
- Supports CE-ATA 1.1.
- Supports 1-bit, 4-bit, and 8-bit MMC cards and CE-ATA devices.

6.10 Universal Serial Bus 2.0 High Speed On-The-Go (OTG)

The USB OTG module allows the LPC3152/3154 to connect directly to a USB host such as a PC (in device mode) or to a USB device in host mode. In addition, the LPC3152/3154 has a special, built-in mode in which it enumerates as a Device Firmware Upgrade (DFU) class, which allows for a (factory) download of the device firmware through USB.

This module has the following features:

- Complies with *Universal Serial Bus specification 2.0*.
- Complies with *USB On-The-Go supplement*.
- Complies with *Enhanced Host Controller Interface Specification*.
- Supports auto USB 2.0 mode discovery.
- Supports all high-speed USB-compliant peripherals.
- Supports all full-speed USB-compliant peripherals.
- Supports software Host Negotiation Protocol (HNP) and Session Request Protocol (SRP) for OTG peripherals.
- Contains UTMI+ compliant transceiver (PHY).
- Supports Interrupts.

- This module has its own, integrated DMA engine.

USB-IF TestID for Hi-speed peripheral silicon and embedded host silicon: 40720018

6.11 DMA controller

The DMA Controller can perform DMA transfers on the AHB bus without using the CPU.

This module has the following features:

- Supported transfer types:
 - Memory to memory copy:
 - Memory can be copied from the source address to the destination address with a specified length, while incrementing the address for both the source and destination.
 - Memory to peripheral:
 - Data is transferred from incrementing memory to a fixed address of a peripheral. The flow is controlled by the peripheral.
 - Peripheral to memory:
 - Data is transferred from a fixed address of a peripheral to incrementing memory. The flow is controlled by the peripheral.
- Supports single data transfers for all transfer types.
- Supports burst transfers for memory to memory transfers. A burst always consists of multiples of 4 (32 bit) words.
- The DMA controller has 12 channels.
- Scatter-gather is used to gather data located at different areas of memory. Two channels are needed per scatter-gather action.
- Supports byte, half word and word transfers, and correctly aligns it over the AHB bus.
- Compatible with ARM flow control, for single requests, last single requests, terminal count info, and dma clearing.
- Supports swapping in endianness of the transported data.

Table 10: Peripherals that support DMA access

Peripheral name	Supported Transfer Types
NAND flash controller/AES decryption engine ^[1]	Memory to memory
SPI	Memory to peripheral and peripheral to memory
MCI	Memory to peripheral and peripheral to memory
LCD Interface	Memory to peripheral
UART	Memory to peripheral and peripheral to memory
I ² C0/1-bus interfaces	Memory to peripheral and peripheral to memory
I ² S0/1 receive input	Peripheral to memory
I ² S0/1 transmit output	Memory to peripheral
PCM interface	Memory to peripheral and peripheral to memory

[1] AES decryption engine is available on LPC3154 only.

6.12 Interrupt controller

The interrupt controller collects interrupt requests from multiple devices, masks interrupt requests, and forwards the combined requests to the processor. The interrupt controller also provides facilities to identify the interrupt requesting devices to be served.

This module has the following features:

- The interrupt controller decodes all the interrupt requests issued by the on-chip peripherals.
- Two interrupt lines (Fast Interrupt Request (FIQ) and Interrupt Request (IRQ)) to the ARM core. The ARM core supports two distinct levels of priority on all interrupt sources, FIQ for high priority interrupts and IRQ for normal priority interrupts.
- Software interrupt request capability associated with each request input.
- Visibility of interrupts request state before masking.
- Support for nesting of interrupt service routines.
- Interrupts routed to IRQ and to FIQ are vectored.
- Level interrupt support.

The following blocks can generate interrupts:

- NAND flash controller
- USB 2.0 HS OTG
- Event router
- 10 bit ADC
- UART
- LCD int
- MCI
- SPI
- I²C0-bus and I²C1-bus
- Timer 0, timer 1, timer 2, and timer 3
- I²S transmit: I2STX_0 and I2STX_1
- I²S receive: I2SRX_0 and I2SRX_1
- DMA

6.13 Multi-layer AHB

The multi-layer AHB is an interconnection scheme, based on the AHB protocol that enables parallel access paths between multiple masters and slaves in a system.

Multiple masters can have access to different slaves at the same time.

[Figure 5](#) gives an overview of the multi-layer AHB configuration in the LPC3152/3154. AHB masters and slaves are numbered according to their AHB port number.

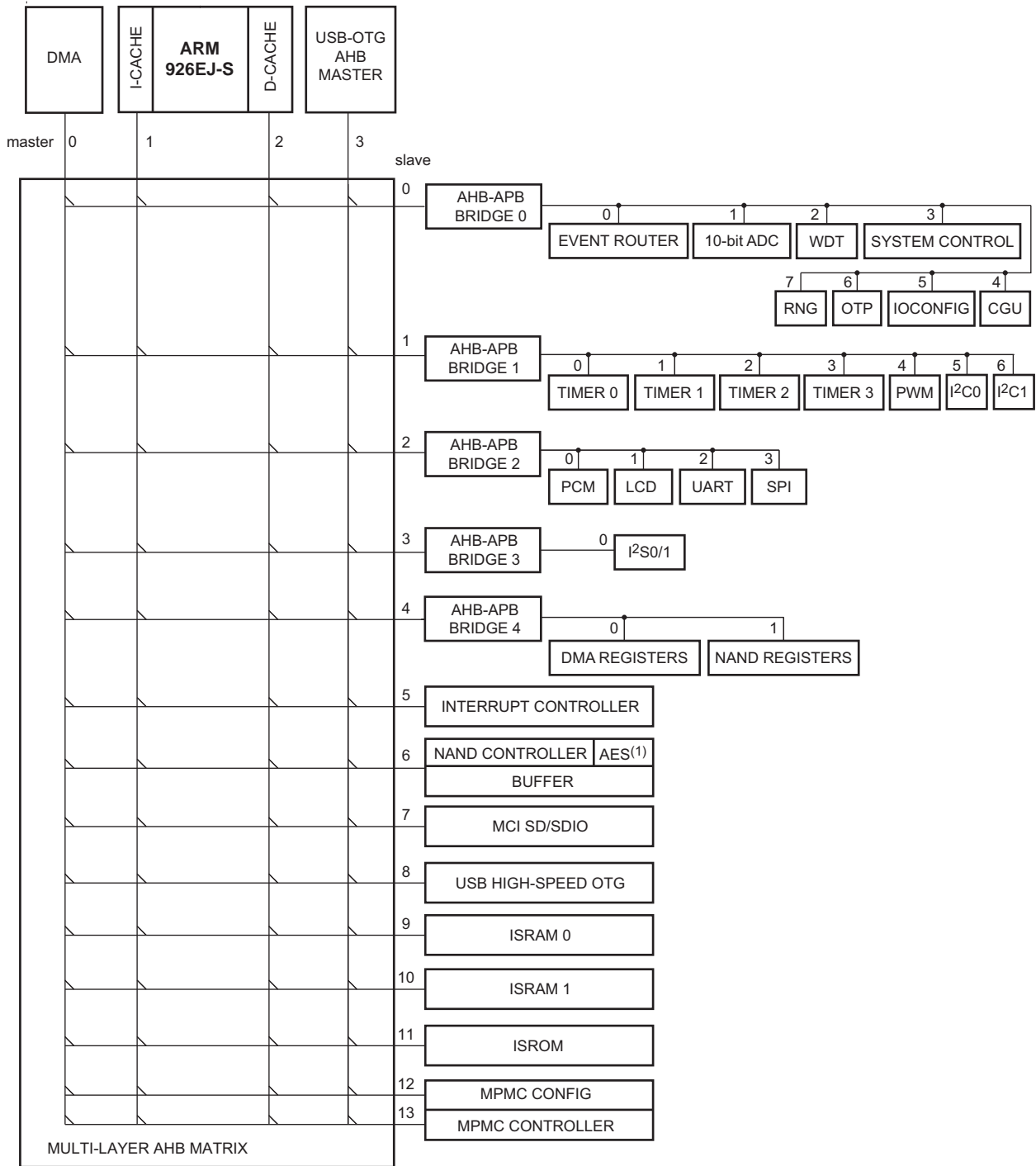

\ = master/slave connection supported by matrix

002aae080

(1) AES decryption engine is available on LPC3154 only.

Fig 5. LPC3152/3154 AHB multi-layer matrix connections

This module has the following features:

- Supports all combinations of 32-bit masters and slaves (fully connected interconnect matrix).
- Round-Robin priority mechanism for bus arbitration: all masters have the same priority and get bus access in their natural order
- Four devices on a master port (listed in their natural order for bus arbitration):
 - DMA
 - ARM926 instruction port
 - ARM926 data port
 - USB OTG
- Devices on a slave port (some ports are shared between multiple devices):
 - AHB to APB Bridge 0
 - AHB to APB Bridge 1
 - AHB to APB Bridge 2
 - AHB to APB Bridge 3
 - AHB to APB Bridge 4
 - Interrupt controller
 - NAND flash controller
 - MCI SD/SDIO
 - USB 2.0 HS OTG
 - 96 kB ISRAM0
 - 96 kB ISRAM1
 - 128 kB ROM
 - MPMC (Multi-Purpose Memory Controller)

6.14 APB bridge

The APB Bridge is a bus bridge between AMBA Advanced High-performance Bus (AHB) and the ARM Peripheral Bus (APB) interface.

The module supports two different architectures:

- Single Clock Architecture, synchronous bridge. The same clock is used at the AHB side and at the APB side of the bridge. The AHB-to-APB4 bridge uses this architecture.
- Dual Clock Architecture, asynchronous bridge. Different clocks are used at the AHB side and at the APB side of the bridge. The AHB-to-APB0, AHB-to-APB1, AHB-to-APB2, and AHB-to-APB3 bridges use this architecture.

6.15 Clock Generation Unit (CGU)

The clock generation unit generates all clock signals in the system and controls the reset signals for all modules.

The structure of the CGU is shown in [Figure 6](#). Each output clock generated by the CGU belongs to one of the domains. Each clock domain is fed by a single base clock that originates from one of the available clock sources. Within a clock domain, fractional dividers are available to divide the base clock to a lower frequency.

Within most clock domains, the output clocks are again grouped into one or more subdomains. All output clocks within one subdomain are either all generated by the same fractional divider or they are connected directly to the base clock. Therefore all output clocks within one subdomain have the same frequency and all output clocks within one clock domain are synchronous because they originate from the same base clock

The CGU reference clock is generated by the external crystal. Furthermore the CGU has several Phase Locked Loop (PLL) circuits to generate clock signals that can be used for system clocks and/or audio clocks. All clock sources, except the output of the PLLs, can be used as reference input for the PLLs.

This module has the following features:

- Advanced features to optimize the system for low power:
 - All output clocks can be disabled individually for flexible power optimization
 - Some modules have automatic clock gating: they are only active when (bus) access to the module is required.
 - Variable clock scaling for automatic power optimization of the AHB bus (high clock frequency when the bus is active, low clock frequency when the bus is idle).
 - Clock wake-up feature: module clocks can be programmed to be activated automatically on the basis of an event detected by the Event Router (see also [Section 6.19](#)). For example, all clocks (including the ARM /bus clocks) are off and activated automatically when a button is pressed.
- Supports three clock sources:
 - Reference clock generated by the oscillator with an external crystal.
 - Pins I2SRX_BCK0, I2SRX_WS0 are used to input external clock signals (used for generating audio frequencies in I²S receive / I²S transmit slave mode, see also [Section 6.4](#)).
- Two PLLs:
 - System PLL generates programmable system clock frequency from its reference input.
 - Audio PLL generates programmable audio clock frequency (typically $256 \times f_s$) from its reference input.
Remark: Both the System PLL and the audio PLL generate their frequencies based on their (individual) reference clocks. The reference clocks can be programmed to the oscillator clock or one of the external clock signals.
- Highly flexible switchbox to distribute the signals from the clock sources to the module clocks.
 - Each clock generated by the CGU is derived from one of the base clocks and optionally divided by a fractional divider.
 - Each base clock can be programmed to have any one of the clock sources as an input clock.

- Fractional dividers can be used to divide a base clock by a fractional number to a lower clock frequency.
- Fractional dividers support clock stretching to obtain a (near) 50% duty cycle output clock.
- Register interface to reset all modules under software control.
- Based on the input of the Watchdog timer (see also [Section 6.16](#)), the CGU can generate a system-wide reset in the case of a system stall.

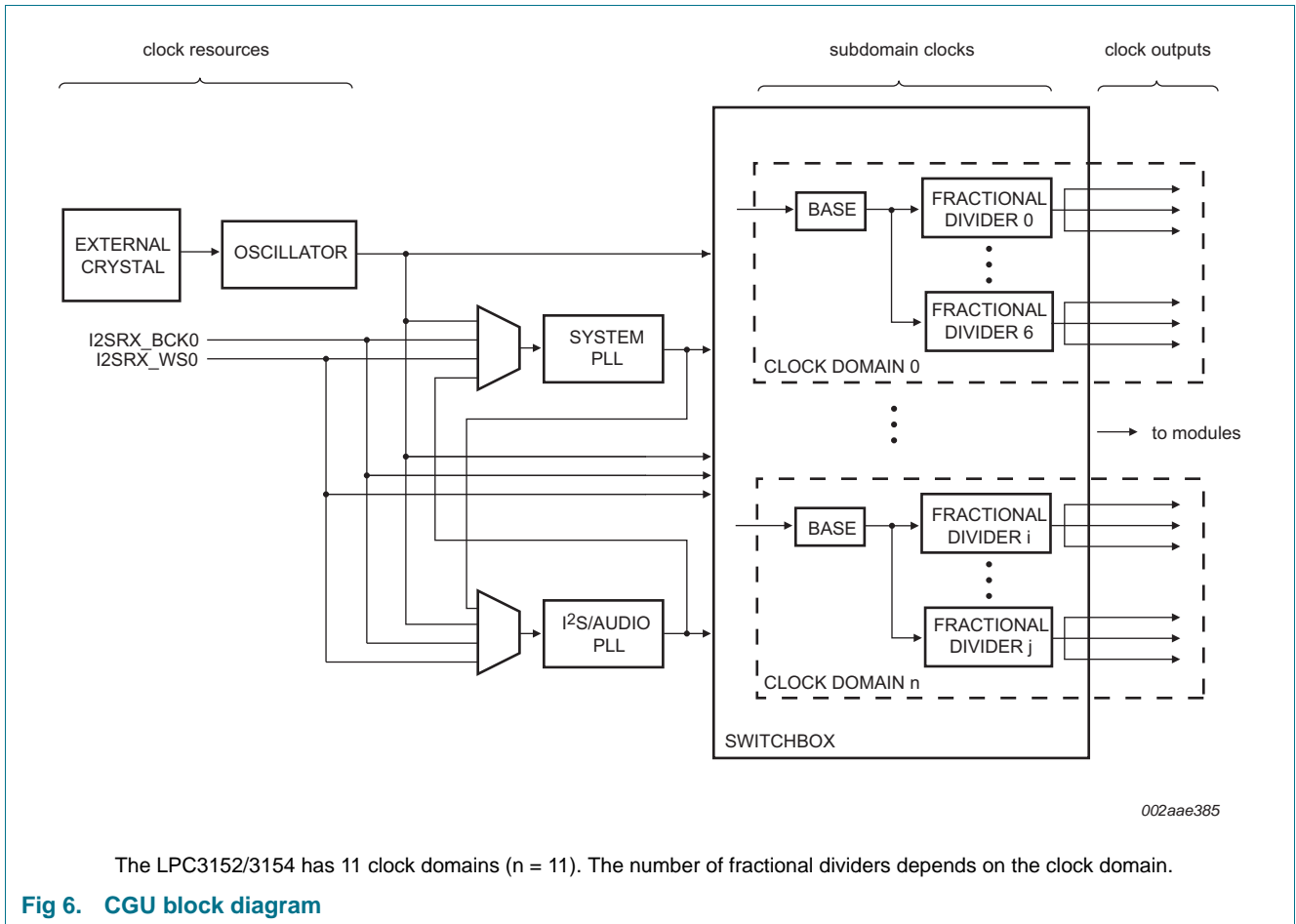

6.16 Watchdog Timer (WDT)

The Watchdog Timer can be used to generate a system reset if there is a CPU/software crash. In addition the watchdog timer can be used as an ordinary timer. [Figure 7](#) shows how the Watchdog Timer module is connected in the system.

This module has the following features:

- In the event of a software or hardware failure, generates a chip-wide reset request when its programmed time-out period has expired (output m1).
- Watchdog counter can be reset by a periodical software trigger.
- After a reset, a register will indicate whether a reset has occurred because of a watchdog generated reset.

- Watchdog timer can also be used as a normal timer in addition to the watchdog functionality (output m0).

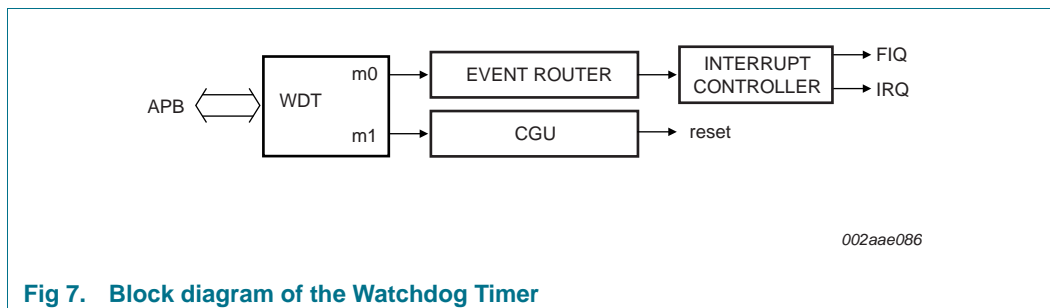

Fig 7. Block diagram of the Watchdog Timer

6.17 Input/Output configuration module (IOCONFIG)

The General Purpose Input/Output (GPIO) pins can be controlled through the register interface provided in the IOCONFIG module. Next to several dedicated GPIO pins, most digital IO pins can also be used as GPIO if they are not required for their normal, dedicated function.

This module has the following features:

- Provides control for the digital pins that can double as GPIO (next to their normal function). The pinning list in [Table 4](#) indicates which pins can double as GPIO.
- Each controlled pin can be configured for 4 operational modes:
 - Normal operation (i.e. controlled by a function block).
 - Driven low.
 - Driven high.
 - High impedance/input.
- A GPIO pin can be observed (read) in any mode.
- The register interface provides set and clear access methods for choosing the operational mode.

6.18 10-bit Analog-to-Digital Converter (ADC10B)

This module is a 10-bit successive approximation Analog-to-Digital Converter (ADC) with an input multiplexer to allow for multiple analog signals on its input. A common use of this module is to read out multiple keys on one input from a resistor network.

This module has the following features:

- Three analog input channels, selected by an analog multiplexer. A fourth channel is connected internally to the analog die to measure the battery level.
- Programmable ADC resolution from 2 bit to 10 bit.
- The maximum conversion rate is 400 ksample/s for 10 bit resolution and 1500 ksample/s for 2 bit resolution.
- Single A/D conversion scan mode and continuous A/D conversion scan mode.
- Power-down mode.

6.19 Event router

The event router extends the interrupt capability of the system by offering a flexible and versatile way of generating interrupts. Combined with the wake-up functionality of the CGU, it also offers a way to wake-up the system from suspend mode (with all clocks deactivated).

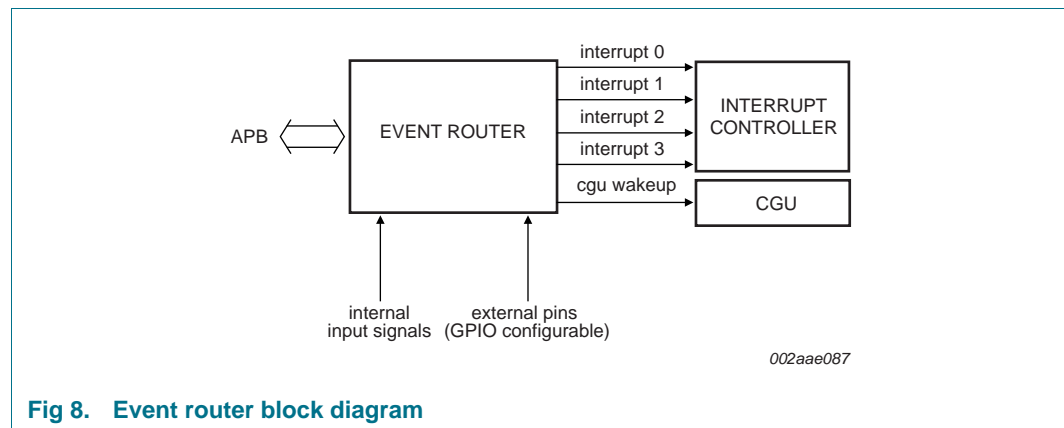

Fig 8. Event router block diagram

The event router has four interrupt outputs connected to the interrupt controller and one wake-up output connected to the CGU as shown in [Figure 8](#). The output signals are activated when an event (for instance a rising edge) is detected on one of the input signals. The input signals of the event router are connected to relevant internal (control) signals in the system or to external signals through pins of the LPC3152/3154.

This module has the following features:

- Provides programmable routing of input events to multiple outputs for use as interrupts or wake up signals.
- Input events can come from internal signals or from the pins that can be used as GPIO.
- Inputs can be used either directly or latched (edge detected) as an event source.
- The active level (polarity) of the input signal for triggering events is programmable.
- Direct events will disappear when the input becomes inactive.
- Latched events will remain active until they are explicitly cleared.
- Each input can be masked globally for all inputs at once.
- Each input can be masked for each output individually.
- Event detect status can be read for each output separately.
- Event detection is fully asynchronous (no active clock required).
- Module can be used to generate a system wake-up from suspend mode.

Remark: All pins that can be used as GPIO are connected to the event router (see [Figure 8](#)). Note that they can be used to trigger events when in normal, functional mode or in GPIO mode.

6.20 Random Number Generator (RNG)

The random number generator generates true random numbers for use in advanced security and Digital Rights Management (DRM) related schemes. These schemes rely upon truly random, i.e. completely unpredictable numbers.

This module has the following features:

- True random number generator.
- The random number register does not rely on any kind of reset.
- The generators are free running in order to ensure randomness and security.

6.21 AES decryption (LPC3154 only)

This module can be used for data decryption using the AES algorithm. The AES module has the following features:

- AES-128: 128 bit key, 128 bit data.
- CBC mode over blocks of 512 bytes.
- Each block of 512 bytes uses the same initial value.
- AES can be turned on and off.

6.22 Secure One-Time Programmable (OTP) memory

The OTP memory can be used for storing non-volatile information like serial number, security bits, etc. It consists of a polyfuse array, embedded data registers, and control registers. One of the main purposes of the OTP is storing a security key and a unique ID.

This module has the following features:

- 512-bit, one-time programmable memory
 - 128 bit are used for an unique ID which is pre-programmed in the wafer fab.
 - 40 bit are used for security and other features which are programmed at the customer production line.
 - 184 bit are available for customer use.
 - 32 bit are used for USB product ID and vendor ID by boot ROM in DFU mode.
 - 128 bit are for the secure key used by boot ROM to load secure images.

Remark: On the LPC3152 secure boot is not supported hence these bits are also available for customer use.

- Programmable at the customer production line
- Random read access via sixteen 32-bit registers
- Flexible read protection mechanism to hide security related data
- Flexible write protection mechanism

6.23 Serial Peripheral Interface (SPI)

The SPI module is used for synchronous serial data communication with other devices which support the SPI/SSI protocol. Examples of the devices that this SPI module can communicate with are memories, cameras, and WiFi-g.

The SPI/SSI-bus is a 5-wire interface, and it is suitable for low, medium, and high data rate transfers.

This module has the following features:

- Supports Motorola SPI frame format with a word size of 8/16 bits.
- Texas Instruments SSI (Synchronous Serial Interface) frame format with a word size of 4 bit to 16 bit.
- Receive FIFO and transmit FIFO of 64 half-words each.
- Serial clock rate master mode maximum 45 MHz.
- Serial clock rate slave mode maximum 25 MHz.
- Support for single data access DMA.
- Full-duplex operation.
- Supports up to three slaves.
- Supports maskable interrupts.
- Supports DMA transfers.

6.24 Universal Asynchronous Receiver Transmitter (UART)

The UART module supports the industry standard serial interface.

This module has the following features:

- Programmable baud rate with a maximum of 1049 kBd.
- Programmable data length (5 bit to 8 bit).
- Implements only asynchronous UART.
- Transmit break character length indication.
- Programmable one to two stops bits in transmission.
- Odd/even/force parity check/generation.
- Frame error, overrun error and break detection.
- Automatic hardware flow control.
- Independent control of transmit, receive, line status, data set interrupts, and FIFOs.
- SIR-IrDA encoder/decoder (from 2400 to 115 kBd).
- Supports maskable interrupts.
- Supports DMA transfers.

6.25 Pulse Code Modulation (PCM) interface

The PCM interface supports the PCM and IOM interfaces.

This module has the following features:

- Four-wire serial interface.
- Can function in both Master and Slave modes.
- Supports:
 - MP PCM (Multi-Protocol PCM): Configurable directional per slot.

- PCM (Pulse Code Modulation): Single clocking physical format.
- IOM-2 (Extended ISDN-Oriented modular): Double clocking physical format.
- Twelve 8 bit slots in a frame with enabling control per slot.
- Internal frame clock generation in master mode.
- Receive and transmit DMA handshaking using a request/clear protocol.
- Interrupt generation per frame.

PCM is a very common method used for transmitting analog data in digital format. Most common applications of PCM are digital audio as in audio CDs and computers, digital telephony, and digital videos.

The IOM (ISDN Oriented Modular) interface is primarily used to interconnect telecommunications ICs providing ISDN compatibility. It delivers a symmetrical full-duplex communication link containing user data, control/programming lines, and status channels.

6.26 LCD interface

The LCD interface contains logic to interface to a 6800 (Motorola) or 8080 (Intel) compatible LCD controller which supports 4/8/16 bit modes. This module also supports a serial interface mode. The speed of the interface can be adjusted in software to match the speed of the connected LCD display.

This module has the following features:

- 4/8/16 bit parallel interface mode: 6800-series, 8080-series.
- Serial interface mode.
- Supports multiple frequencies for the 6800/8080 bus to support high- and low-speed controllers.
- Supports polling the busy flag from LCD controller to off-load the CPU from polling.
- Contains an 16 byte FIFO for sending control and data information to the LCD controller.
- Supports maskable interrupts.
- Supports DMA transfers.

6.27 I²C-bus master/slave interface

The LPC3152/3154 contains two I²C master/slave interfaces. I²C-bus 0 can be used for communicating directly with I²C-compatible external devices. I²C-bus 1 is internally connected to support the following analog blocks: Li-ion charger, power supply unit, RTC, audio ADC, audio DAC, and class AB amplifier.

This module has the following features:

- **I²C0 interface:** I²C0 is a standard I²C-compliant bus interface with open-drain pins. This interface supports functions described in the I²C specification for speeds up to 400 kHz. This includes multi-master operation and allows powering off this device in a working system while leaving the I²C-bus functional.
- **I²C1 interface:** internally connected to control the functions on the analog die.
- Supports normal mode (100 kHz SCL).

- Fast mode (400 kHz SCL with 24 MHz APB clock; 325 kHz with 12 MHz APB clock; 175 kHz with 6 MHz APB clock).
- Interrupt support.
- Supports DMA transfers (single).
- Four modes of operation:
 - Master transmitter
 - Master receiver
 - Slave transmitter
 - Slave receiver

6.28 LCD/NAND flash/SDRAM multiplexing

The LPC3152/3154 contains a rich set of specialized hardware interfaces, but the TFBGA package does not contain enough pins to allow use of all signals of all interfaces simultaneously. Therefore a pin-multiplexing scheme is implemented, which allows the selection of the right interface for the application.

Pin multiplexing is enabled between the following interfaces:

- between the dedicated LCD interface and the External Bus Interface (EBI).
- between the NAND flash controller and the Memory Card Interface (MCI).
- between UART and SPI.
- between I2STX_0 output and the PCM interface.

The pin interface multiplexing is subdivided into five categories: storage, video, audio, NAND flash, and UART related pin multiplexing. Each category supports several modes, which can be selected by programming the corresponding registers in the SysCReg.

6.28.1 Pin connections

Table 11. Pin descriptions of multiplexed pins

Pin name	Default signal	Alternate signal	Description
Video related pin multiplexing			
mLCD_CSB	LCD_CSB	EBI_NSTCS_0	LCD_CSB — LCD chip select for external LCD controller. EBI_NSTCS_0 — EBI static memory chip select 0.
mLCD_DB_1	LCD_DB_1	EBI_NSTCS_1	LCD_DB_1 — LCD bidirectional data line 1. EBI_NSTCS_1 — EBI static memory chip select 1.
mLCD_DB_0	LCD_DB_0	EBI_CLKOUT	LCD_DB_0 — LCD bidirectional data line 0. EBI_CLKOUT — EBI SDRAM clock signal.
mLCD_E_RD	LCD_E_RD	EBI_CKE	LCD_E_RD — LCD enable/read signal. EBI_CKE — EBI SDRAM clock enable.
mLCD_RS	LCD_RS	EBI_NDYCS	LCD_RS — LCD register select signal. EBI_NDYCS — EBI SDRAM chip select.
mLCD_RW_WR	LCD_RW_WR	EBI_DQM_1	LCD_RW_WR — LCD read write/write signal. EBI_DQM_1 — EBI SDRAM data mask output 1.
mLCD_DB_2	LCD_DB_2	EBI_A_2	LCD_DB_2 — LCD bidirectional data line 2. EBI_A_2 — EBI address line 2.

Table 11. Pin descriptions of multiplexed pins

Pin name	Default signal	Alternate signal	Description
mLCD_DB_3	LCD_DB_3	EBI_A_3	LCD_DB_3 — LCD bidirectional data line 3. EBI_A_3 — EBI address line 3.
mLCD_DB_4	LCD_DB_4	EBI_A_4	LCD_DB_4 — LCD bidirectional data line 4. EBI_A_4 — EBI address line 4.
mLCD_DB_5	LCD_DB_5	EBI_A_5	LCD_DB_5 — LCD bidirectional data line 5. EBI_A_5 — EBI address line 5.
mLCD_DB_6	LCD_DB_6	EBI_A_6	LCD_DB_6 — LCD bidirectional data line 6. EBI_A_6 — EBI address line 6.
mLCD_DB_7	LCD_DB_7	EBI_A_7	LCD_DB_7 — LCD bidirectional data line 7. EBI_A_7 — EBI address line 7.
mLCD_DB_8	LCD_DB_8	EBI_A_8	LCD_DB_8 — LCD bidirectional data line 8. EBI_A_8 — EBI address line 8.
mLCD_DB_9	LCD_DB_9	EBI_A_9	LCD_DB_9 — LCD bidirectional data line 9. EBI_A_9 — EBI address line 9.
mLCD_DB_10	LCD_DB_10	EBI_A_10	LCD_DB_10 — LCD bidirectional data line 10. EBI_A_10 — EBI address line 10.
mLCD_DB_11	LCD_DB_11	EBI_A_11	LCD_DB_11 — LCD bidirectional data line 11. EBI_A_11 — EBI address line 11.
mLCD_DB_12	LCD_DB_12	EBI_A_12	LCD_DB_12 — LCD bidirectional data line 12. EBI_A_12 — EBI address line 12.
mLCD_DB_13	LCD_DB_13	EBI_A_13	LCD_DB_13 — LCD bidirectional data line 13. EBI_A_13 — EBI address line 13.
mLCD_DB_14	LCD_DB_14	EBI_A_14	LCD_DB_14 — LCD bidirectional data line 14. EBI_A_14 — EBI address line 14.
mLCD_DB_15	LCD_DB_15	EBI_A_15	LCD_DB_15 — LCD bidirectional data line 15. EBI_A_15 — EBI address line 15.

Storage related pin multiplexing

mGPIO5	GPIO5	MCI_CLK	GPIO5 — General Purpose I/O pin 5. MCI_CLK — MCI card clock.
mGPIO6	GPIO6	MCI_CMD	GPIO_6 — General Purpose I/O pin 6. MCI_CMD — MCI card command input/output.
mGPIO7	GPIO7	MCI_DAT_0	GPIO7 — General Purpose I/O pin 7. MCI_DAT_0 — MCI card data input/output line 0.
mGPIO8	GPIO8	MCI_DAT_1	GPIO8 — General Purpose I/O pin 8. MCI_DAT_1 — MCI card data input/output line 1.
mGPIO9	GPIO9	MCI_DAT_2	GPIO9 — General Purpose I/O pin 9. MCI_DAT_2 — MCI card data input/output line 2.
mGPIO10	GPIO10	MCI_DAT_3	GPIO10 — General Purpose I/O pin 10. MCI_DAT_3 — MCI card data input/output line 3.

Table 11. Pin descriptions of multiplexed pins

Pin name	Default signal	Alternate signal	Description
NAND flash related pin multiplexing			
mNAND_RYBN0	NAND_RYBN0	MCI_DAT_4	NAND_RYBN0 — NAND flash controller Read/Not busy signal 0. MCI_DAT_4 — MCI card data input/output line 4.
mNAND_RYBN1	NAND_RYBN1	MCI_DAT_5	NAND_RYBN1 — NAND flash controller Read/Not busy signal 1. MCI_DAT_5 — MCI card data input/output line 5.
mNAND_RYBN2	NAND_RYBN2	MCI_DAT_6	NAND_RYBN2 — NAND flash controller Read/Not busy signal 2. MCI_DAT_6 — MCI card data input/output line 6.
mNAND_RYBN3	NAND_RYBN3	MCI_DAT_7	NAND_RYBN3 — NAND flash controller Read/Not busy signal 3. MCI_DAT_7 — MCI card data input/output line 7.
Audio related pin multiplexing			
mI2STX_DATA0	I2STX_DATA0	PCM_DA	I2STX_DATA0 — I2S interface 0 transmit data signal. PCM_DA — PCM serial data line A.
mI2STX_BCK0	I2STX_BCK0	PCM_FSC	I2STX_BCK0 — I2S interface 0 transmit bitclock signal. PCM_FSC — PCM frame synchronization signal.
mI2STX_WS0	I2STX_WS0	PCM_DCLK	I2STX_WS0 — I2S interface 0 transmit word select signal. PCM_DCLK — PCM data clock output.
mI2STX_CLK0	I2STX_CLK0	PCM_DB	I2STX_CLK0 — I2S interface 0 transmit clock signal. PCM_DB — PCM serial data line B.
UART related pin multiplexing			
mUART_CTS_N	UART_CTS_N	SPI_CS_OUT1	UART_CTS_N — UART modem control Clear-to-Send signal. SPI_CS_OUT1 — SPI chip select out for slave 1 (used in master mode).
mUART_RTS_N	UART_RTS_N	SPI_CS_OUT2	UART_RTS_N — UART modem control Request-to-Send signal. SPI_CS_OUT2 — SPI chip select out for slave 2 (used in master mode).

6.28.2 Multiplexing between LCD and MPMC

The multiplexing between the LCD interface and MPMC allows for the following two modes of operation:

- MPMC-mode: SDRAM and bus-based LCD or SRAM.
- LCD-mode: Dedicated LCD-Interface.

The external NAND flash is accessible in both modes.

The block diagram [Figure 9](#) gives a high level overview of the modules in the chip that are involved in the pin interface multiplexing between the EBI, NAND flash controller, MPMC, and RAM-based LCD interface.

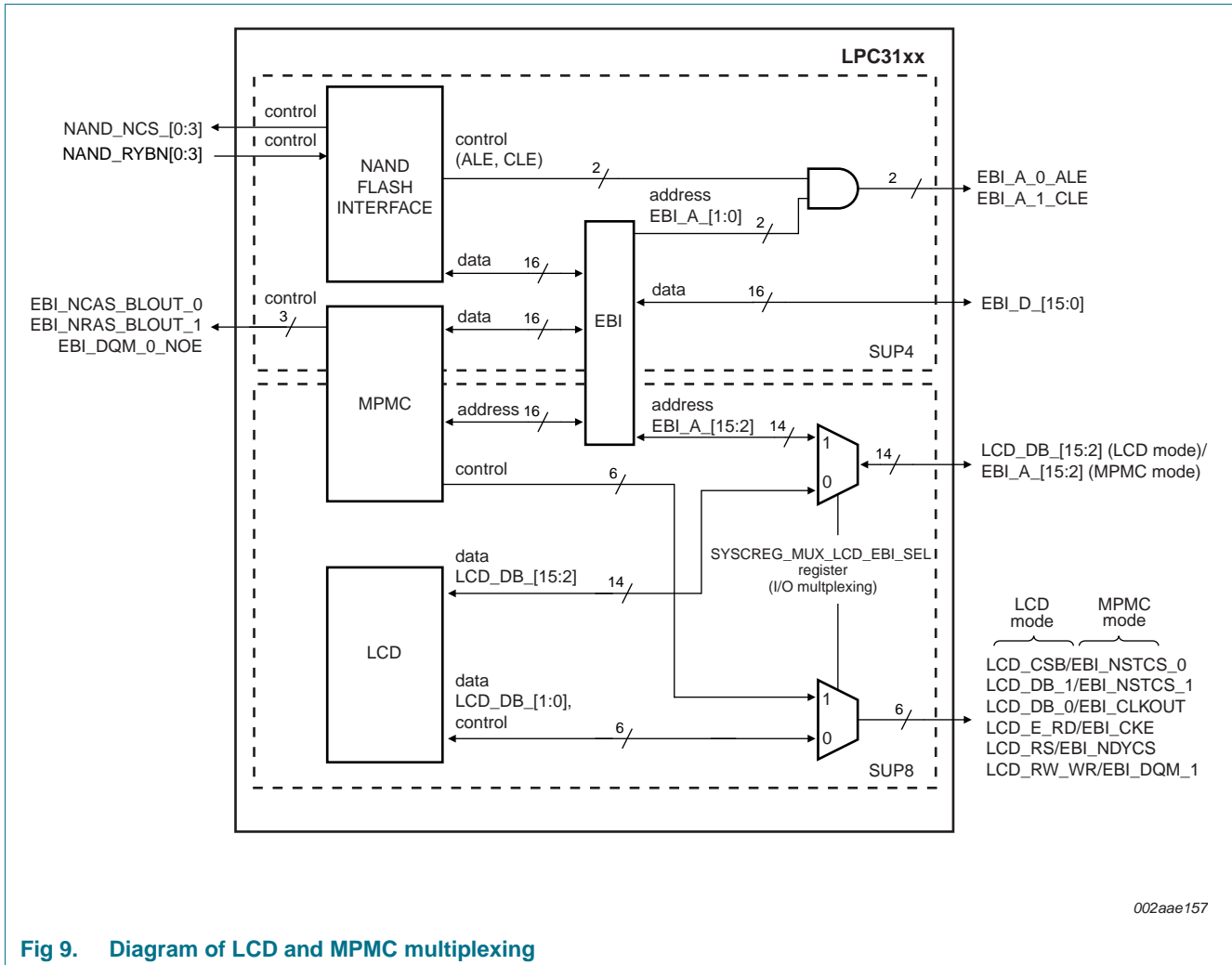

Fig 9. Diagram of LCD and MPMC multiplexing

Figure 9 only shows the signals that are involved in pad-muxing, so not all interface signals are visible.

The EBI unit between the NAND flash interface and the MPMC contains an arbiter that determines which interface is muxed to the outside world. Both NAND flash and SDRAM/SRAM initiate a request to the EBI unit. This request is granted using round-robin arbitration (see Section 6.6).

6.28.3 Supply domains

As is shown in Figure 9 the EBI (NAND flash/MPMC-control/data) is connected to a different supply domain than the LCD interface. The EBI control and address signals are muxed with the LCD interface signals and are part of supply domain SUP8. The SDRAM/SRAM data lines are shared with the NAND flash through the EBI and are part of supply domain SUP4. Therefore the following rules apply for connecting memories:

1. SDRAM and bus-based LCD or SRAM: This is the MPMC mode. The supply voltage for SDRAM/SRAM/bus-based LCD and NAND flash must be the same. The dedicated LCD interface is not available in this MPMC mode.

2. Dedicated LCD interface only: This is the LCD mode. The NAND flash supply voltage (SUP4) can be different from the LCD supply voltage (SUP8).

6.29 Timer module

The LPC3152/3154 contains four fully independent timer modules, which can be used to generate interrupts after a pre-set time interval has elapsed.

This module has the following features:

- Each timer is a 32 bit wide down-counter with selectable pre-scale. The pre-scaler allows using either the module clock directly or the clock divided by 16 or 256.
- Two modes of operation:
 - Free-running timer: The timer generates an interrupt when the counter reaches zero. The timer wraps around to 0xFFFF FFFF and continues counting down.
 - Periodic timer: The timer generates an interrupt when the counter reaches zero. It reloads the value from a load register and continues counting down from that value. An interrupt will be generated every time the counter reaches zero. This effectively gives a repeated interrupt at a regular interval.
- At any time the current timer value can be read.
- At any time the value in the load register may be re-written, causing the timer to restart.

6.30 Pulse Width Modulation (PWM) module

This PWM can be used to generate a pulse width modulated or a pulse density modulated signal. With an external low pass filter, the module can be used to generate a low frequent analog signal. A typical use of the output of the module is to control the backlight of an LCD display.

This module has the following features:

- Supports Pulse Width Modulation (PWM) with software controlled duty cycle.
- Supports Pulse Density Modulation (PDM) with software controlled pulse density.

6.31 System control registers

The System Control Registers (SysCReg) module provides a register interface for some of the high-level settings in the system such as multiplexers and mode settings. This is an auxiliary module included in this overview for the sake of completeness.

6.32 Audio Subsystem (ADSS)

The audio subsystem consists of the following blocks:

- I²S interfaces on the digital die (see [Section 6.32.1](#)):
 - I²S0 digital audio input/output (I2SRX_0/I2STX_0)
 - I²S1 (I2SRX_1/I2STX_1) interface to the audio analog block (I²S1 signals not pinned out)
 - Edge detector

- Audio codec on the analog die (see [Section 7.2](#)):
 - Class AB amplifier
 - Stereo Analog-to-Digital Converter (SADC)
 - analog inputs/outputs
 - Analog Volume Control (AVC)
 - Stereo Digital-to-Analog Converter (SDAC)
- I²S and I²C interfaces on the analog die for communication with the digital die.

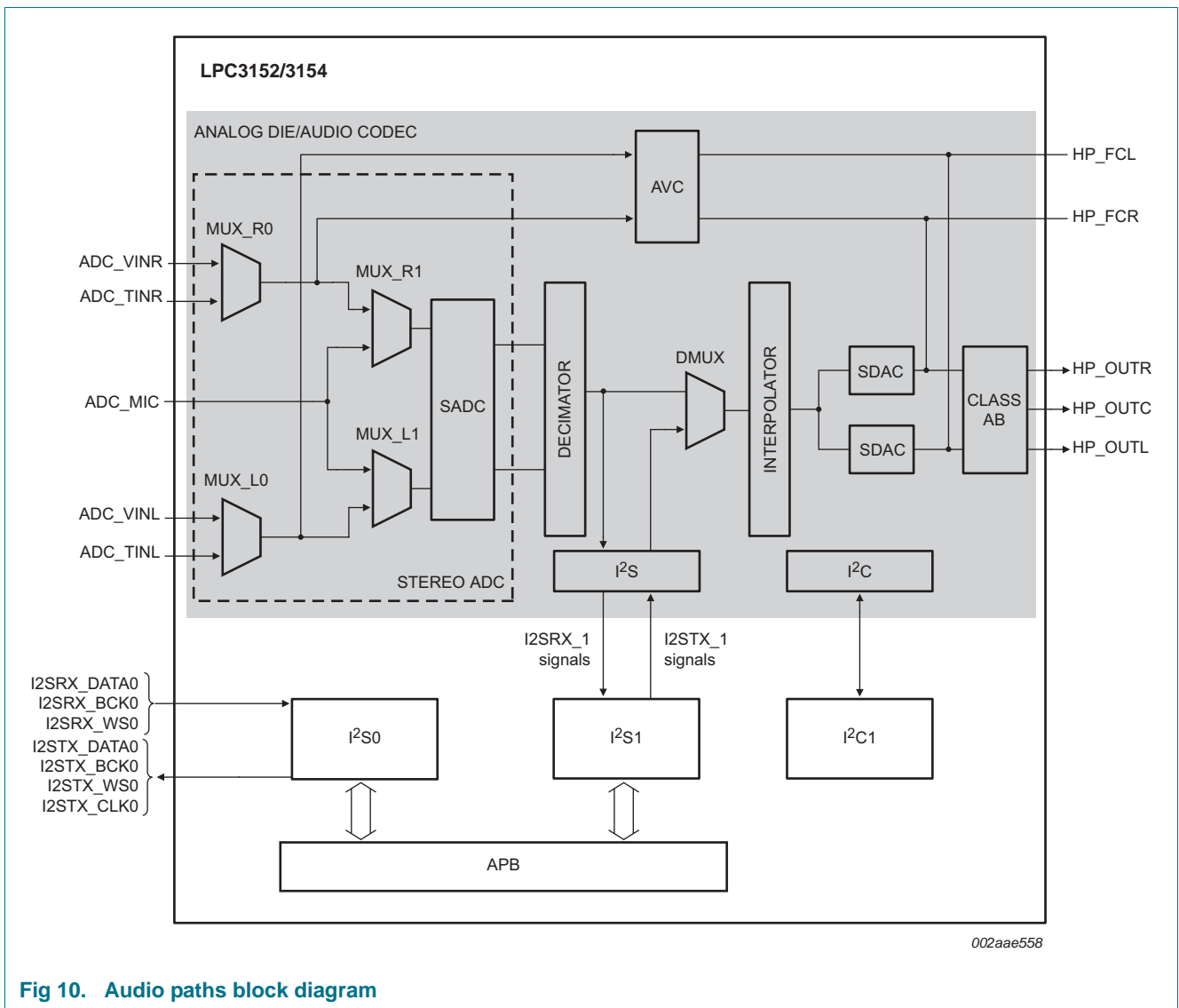

Fig 10. Audio paths block diagram

6.32.1 I²S0/1 digital audio input/output

The I²S0/1 audio module provides a 3-wire digital audio interface that complies with the I²S standard.

Remark: In the LPC3152/3154, the I²S0 interface is pinned out. The I²S1 interface is internally connected to the analog die.

The I²S0/1 module has the following features:

- Receive input supports master mode and slave mode.
- Transmit output supports master mode.
- Supports LSB justified words of 16, 18, 20 and 24 bits.
- Supports a configurable number of bit clock periods per word select period (up to 128 bit clock periods).
- Supports DMA transfers.
- Transmit FIFO or receive FIFO of 4 stereo samples.
- Supports single 16-bit transfers to/from the left or right FIFO.
- Supports single 24-bit transfers to/from the left or right FIFO.
- Supports 32-bit interleaved transfers, with the lower 16 bits representing the left audio sample and the higher 16 bits representing the right audio sample.
- Supports two 16-bit samples audio samples combined in a 32-bit word (2 left or 2 right samples) to reduce bus load.
- Provides maskable interrupts for audio status.
(FIFO underrun/overrun/full/half_full/not empty for left and right channel separately).

7. Functional description of the analog die blocks

7.1 Analog die

The analog die part of the LPC3152/3154 contains the audio codec, the Real-Time Clock (RTC), the Power Supply Unit (PSU), the Li-ion charger, and the USB charge pump.

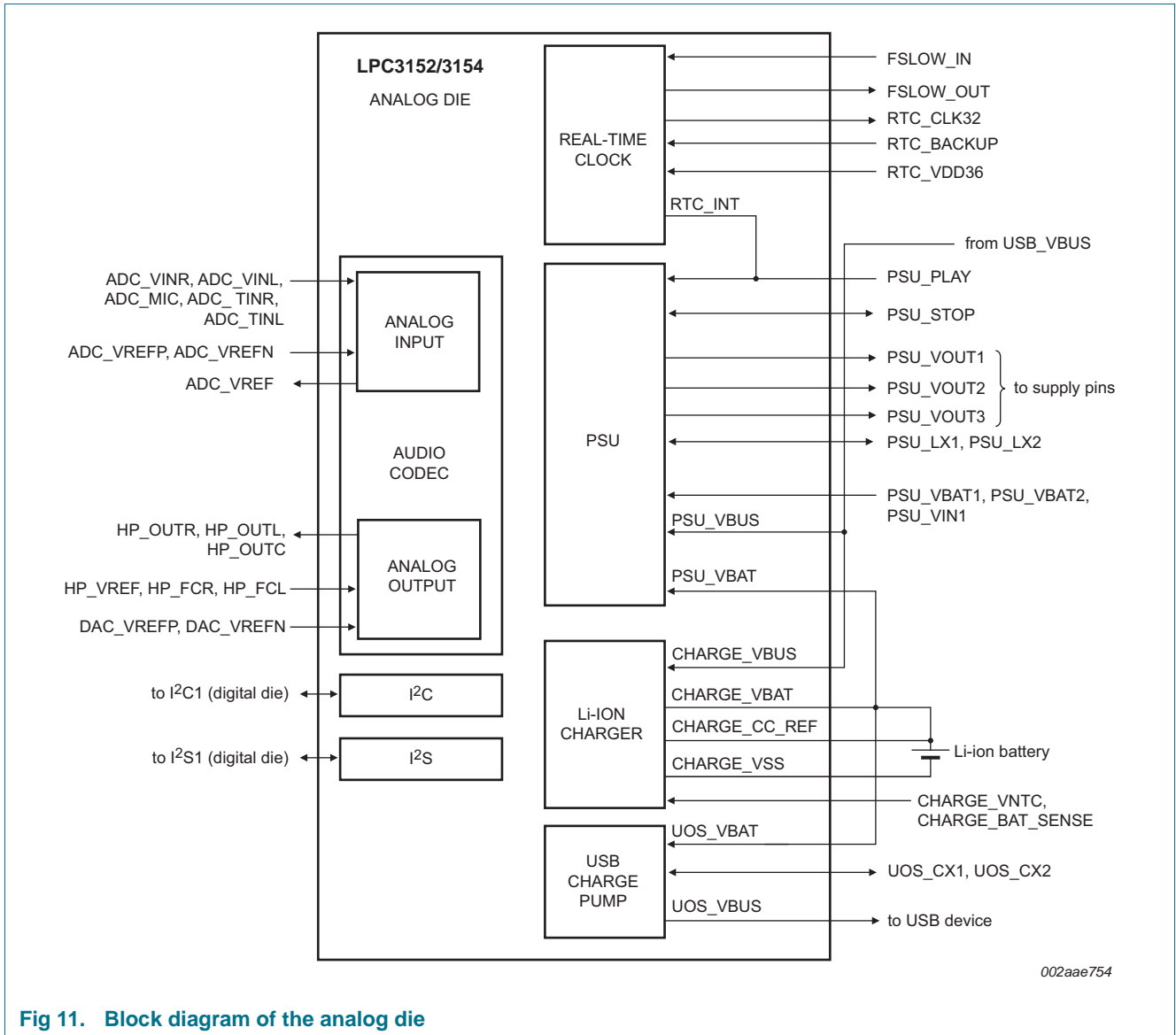

Fig 11. Block diagram of the analog die

7.2 Audio codec

7.2.1 Stereo Digital-to-Analog Converter (SDAC)

The Stereo Digital-to-Analog Converter converts a digital audio signal into an analog audio signal. The output of this module is connected to the input of the class AB headphone amplifier.

This module has the following features:

- Stereo Digital-to-Analog converter with support for 24-bit audio samples.
- Supports sample rates from 8 kHz up to 96 kHz.
- Filter implementations have a 24-bit data path with 16-bit coefficients.
- Full FIR filter implementation for all of the up-sampling filters.

- Controlled power down sequence comprising a raised cosine mute function followed by a DC ramp down to zero to avoid audible plops or clicks.
- Digital dB-linear volume control in 0.25 dB steps.
- Digital de-emphasis for 32 kHz, 44.1 kHz, 48 kHz, and 96 kHz.
- Selection for the up-sampling filter characteristics (sharp/slow roll-off).
- Support for 2fs and 8fs input signals.
- Soft mute with a raised cosine function.

7.2.2 Class AB headphone amplifier

The class AB headphone amplifier amplifies an analog input signal to levels appropriate for a headphone output. Its input can be chosen from the Stereo Digital-to-Analog Converter (SADC) or from the analog bypass from the tuner input (through the Analog Volume Control (AVC) block). The class AB amplifier offers a solution in cases where high output levels are required or when the headphone wire is also used as an antenna for tuner reception.

This module has the following features:

- Stereo headphone amplifier.
- Three outputs: left, right, and a common signal ground output.
- Common signal ground output enables DC coupling of headphone without electrolytic capacitors.
- 16 Ω and higher output drive capability.
- Individual power down modes for each output.
- Programmable short-circuit current protection for each amplifier.
- Additional input with Analog Volume Control (AVC) directly connected to the tuner input pins.

7.2.3 Stereo Analog-to-Digital Converter (SADC) for Audio

The Stereo ADC can convert analog audio input signals into digital audio signals as shown in [Figure 12](#). The module has three input signals: stereo line-in (ADC_VINL/ADC_VINR), stereo tuner-in (ADC_TINL/ADC_TINR), and mono microphone in (ADC_MIC). These signals can be pre-processed by a Low-Noise Amplifier (LNA, microphone input only), a Programmable Gain Amplifier (PGA), and a Single-to-Differential Converter (SDC) before they arrive at the input of the actual SADC.

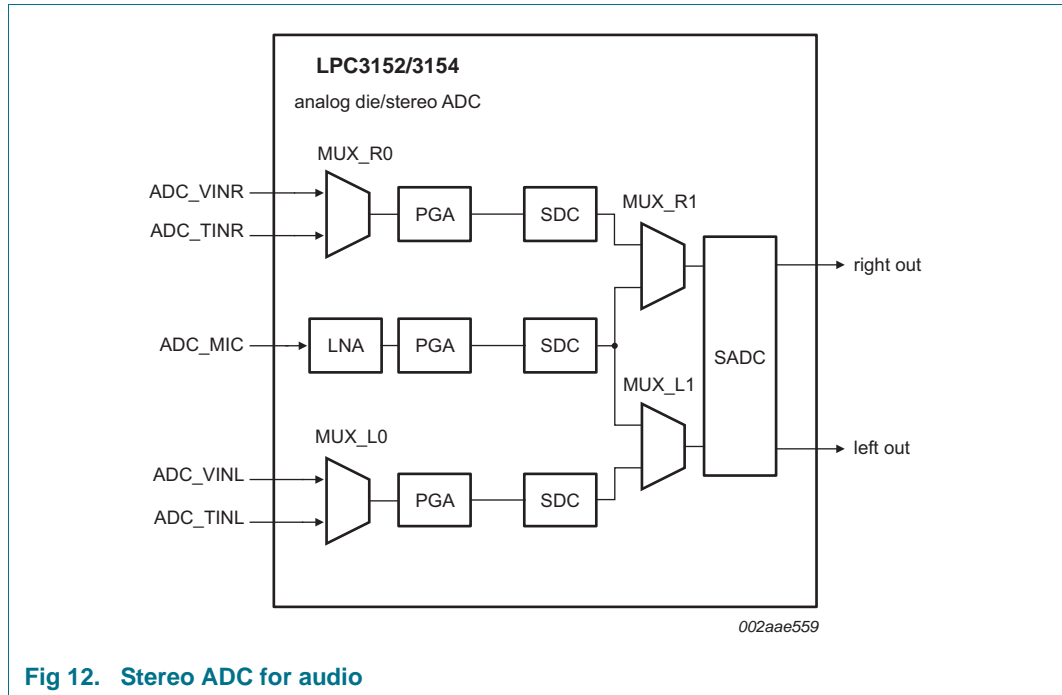

Fig 12. Stereo ADC for audio

This module has the following features:

- Three input options: line-in (stereo), tuner-in (stereo), microphone-in (mono).
- Low-Noise Amplifier (LNA) with a fixed 30 dB gain for the microphone input.
- Programmable Gain Amplifier (PGA). Gain can be set in steps of 3 dB up to 24 dB.
- Single-to-Differential Converter (SDC).
- SADC (switched cap).
- Supported audio sample frequencies are 8 kHz to 55 kHz.
- Oversampling rate 128 times the sample frequency.
- High dynamic range.
- Digital dB-linear volume control in 0.5 dB steps.
- DC blocking filter (optional).
- Soft start-up.
- Mute and overflow detection.

7.3 Li-ion charger

The built-in charger allows a Li-ion battery to be charged from the power supplied by a USB connection or by an AC adapter.

This module has the following features:

- Monitors for battery voltage, charge current, battery temperature feedback (NTC), and chip temperature (programmable temperature limits).
- Maximum charge current 250 mA.

- The nominal charge current is programmed with an external program-resistor. This allows the charge current to be adapted to the USB enumeration.
- Uses a widespread method to charge a Li-ion battery with the following stages:
 - Trickle charging with a small current for an (almost) empty battery.
 - Fast charging in Constant Current mode (CC mode) to the maximum battery voltage of $4.2\text{ V} \pm 1\%$.
 - Switch from CC mode to Constant Voltage charging (CV mode) keeping the battery voltage at 4.2 V and monitoring the current for ending the charge process.
- Short circuit resistant.
- Charger state can be observed through a register.

7.4 USB charge pump (host mode)

The USB charge pump uses the Li-ion battery to provide a low-power USB VBUS signal for the USB controller in host mode.

7.5 Power Supply Unit (PSU)

The integrated PSU allows the system to run directly from the battery voltage or the USB power supply voltage USB_VBUS. It converts the battery voltage or the USB_VBUS voltage into the supply voltages required for both the digital and analog blocks in the rest of the system.

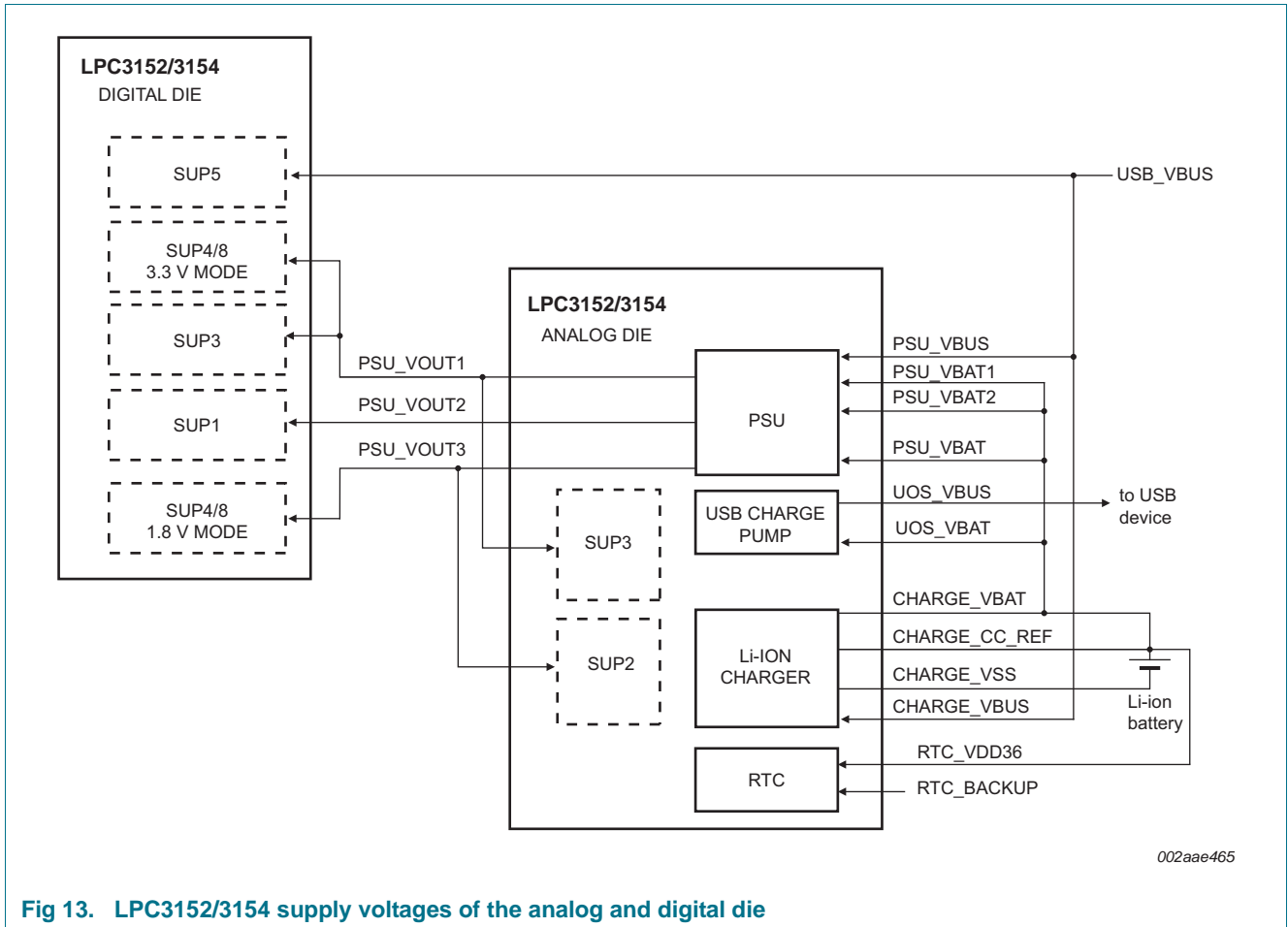

Fig 13. LPC3152/3154 supply voltages of the analog and digital die

This module has the following features:

- Takes power from the Li-Ion battery or the USB power supply.
- Outputs in Li-Ion battery mode:
 - PSU_VOUT1, 2.4 V to 3.2 V (software programmable in 8 levels), 100 mA (analog power supply and I/O).
 - PSU_VOUT2, 0.9 V to 1.4 V (software programmable in 8 levels), 100 mA (digital power supply).
 - PSU_VOUT3, 1.4 V or 1.8 V (software selectable), 50 mA (digital power supply).
 - PSU_VOUT1 and PSU_VOUT2 are generated by two inductive DC-to-DC buck converters with internal power switches.
 - PSU_VOUT3 is generated by an LDO from PSU_VOUT1.
- Outputs in USB power supply mode:
 - PSU_VOUT1, 3.3 V, 80 mA.
 - PSU_VOUT2, 1.2 V, 80 mA.
 - PSU_VOUT3, 1.4 V or 1.8 V (software selectable), 50 mA.
 - PSU_VOUT1 is generated by an LDO from the 5 V USB power supply.
 - PSU_VOUT2 and PSU_VOUT3 are generated by an LDO from PSU_VOUT1.

- Provides 'Supply_OK' detection connected to the system reset signal.

7.6 Real-Time Clock (RTC)

The Real-Time Clock module keeps track of the actual date and time, also when the system is switched off. Advanced Digital Rights Management (DRM) schemes require a secure and accurate real-time clock for managing rights such as time-limited playback rights.

This module has the following features:

- Normal power supply directly from Li-ion battery (PSU is by-passed).
- Backup power supply from (external) capacitor.
- Automatic switching between normal power supply and backup power supply.
- Signals power loss to indicate invalid real time clock readings.
- Runs on a 32 kHz oscillator.
- Ultra-low power consumption.
- The clock is implemented as a 32-bit counter at the rate of 1 Hz (derived from the 32 kHz clock).
- Alarm timer that can generate an interrupt. This interrupt is available both as an internal signal as well as a signal on an external pin.
- The external interrupt (RTC_INT) can be used to switch on the system by switching on the PSU through the PSU_PLAY pin.
- The internal interrupt signal can be used to wake-up the system from suspend mode through the event router.
- Dedicated permanent supply domain.

8. Limiting values

Table 12. Limiting values

In accordance with the Absolute Maximum Rating System (IEC 60134).^[1]

Symbol	Parameter	Conditions	Min	Typ	Max	Unit
All digital I/O pins						
V _I	input voltage		-0.5	-	+3.6	V
V _O	output voltage		-0.5	-	+3.6	V
I _O	output current	VDDE_IOC = 3.3 V	-	4	-	mA
Temperature values						
T _j	junction temperature		-40	25	125	°C
T _{stg}	storage temperature	^[2]	-65	-	+150	°C
T _{amb}	ambient temperature		-40	+25	+85	°C
Electrostatic handling						
V _{ESD}	electrostatic discharge voltage	human body model ^[3]	-500	-	+500	V
		machine model	-100	-	+100	V
		charged device model	-	500	-	V

[1] The following applies to the limiting values:

- a) This product includes circuitry specifically designed for the protection of its internal devices from the damaging effects of excessive static charge. Nonetheless, it is suggested that conventional precautions be taken to avoid applying greater than the rated maximum.
- b) Parameters are valid over operating temperature range unless otherwise specified. All voltages are with respect to V_{SS} unless otherwise noted.

[2] Dependent on package type.

[3] Human body model: equivalent to discharging a 100 pF capacitor through a 1.5 kΩ series resistor.

9. Static characteristics

9.1 Digital die

Table 13: Static characteristics

$T_{amb} = -40\text{ °C}$ to $+85\text{ °C}$ unless otherwise specified.

Symbol	Parameter	Conditions	Min	Typ	Max	Unit
Supply pins						
$V_{DD(IO)}$	input/output supply voltage	NAND flash controller pads (SUP4) and LCD interface (SUP8); 1.8 V mode	1.65	1.8	1.95	V
		NAND flash controller pads (SUP4) and LCD interface (SUP8); 3.3 V mode	2.5	3.3	3.6	V
		other peripherals (SUP 3)	2.7	3.3	3.6	V
$V_{DD(CORE)}$	core supply voltage	(SUP1)	1.1	1.2	1.3	V
$V_{DD(OSC_PLL)}$	oscillator and PLL supply voltage	on pin VDDA12; for 12 MHz oscillator (SUP1)	1.0	1.2	1.3	V
$V_{DD(ADC)}$	ADC supply voltage	on pin ADC10B_VDDA33; for 10-bit ADC (SUP 3)	2.7	3.3	3.6	V
$V_{prog(pf)}$	polyfuse programming voltage	on pin VPP; write	3.0	3.3	3.6	V
		on pin VPP; read	1.1	-	1.3	V
V_{BUS}	bus supply voltage	on pin USB_VBUS (SUP5)	-	5.0	-	V
$V_{DDA(USB)(3V3)}$	USB analog supply voltage (3.3 V)	on pin USB_VDDA33 (SUP 3)	3.0	3.3	3.6	V
		on pin USB_VDDA33_DRV (SUP 3); driver	2.7	3.3	3.6	V
$V_{DDA(PLL)(1V2)}$	PLL analog supply voltage (1.2 V)	on pin USB_VDDA12_PLL (SUP1)	1.1	1.2	1.3	V
Input pins and I/O pins configured as input						
V_I	input voltage		0	-	VDDE_IOC	V
V_{IH}	HIGH-level input voltage	SUP3; SUP4; SUP8	$0.7VDDE_IOx$ (x = A, B, C)	-	-	V
V_{IL}	LOW-level input voltage	SUP3; SUP4; SUP8	-	-	$0.3VDDE_IOx$ (x = A, B, C)	V
V_{hys}	hysteresis voltage	SUP4; SUP8;				V
		1.8 V mode	400	-	600	mV
		3.3 V mode	550	-	850	mV
		SUP3	$0.1VDDE_IOC$	-	-	V
I_{IL}	LOW-level input current	$V_I = 0\text{ V}$; no pull-up	-	-	2.1	μA

Table 13: Static characteristics

$T_{amb} = -40\text{ }^{\circ}\text{C}$ to $+85\text{ }^{\circ}\text{C}$ unless otherwise specified.

Symbol	Parameter	Conditions	Min	Typ	Max	Unit	
I_{IH}	HIGH-level input current	$V_I = V_{DD(I/O)}$; no pull-down	-	-	3.9	μA	
I_{latch}	I/O latch-up current	$-(1.5V_{DD(I/O)}) < V_I < (1.5V_{DD(I/O)})$	[1]	-	100	mA	
I_{pu}	pull-up current	inputs with pull-up; $V_I = 0$;					
		SUP4; SUP8; 1.8 V mode	[1]	47	65	103	μA
		SUP4; SUP8; 3.3 V mode	[1]	45	50	101	μA
I_{pd}	pull-down current	inputs with pull-down; $V_I = V_{DD}$;					
		SUP4; SUP8; 1.8 V mode	[1]	49	75	110	μA
		SUP4; SUP8; 3.3 V mode	[1]	56	50	110	μA
		SUP3	[1]	25	50	68	μA

Output pins and I/O pins configured as output

V_O	output voltage		-	-	$V_{DD(I/O)}$	V	
V_{OH}	HIGH-level output voltage	SUP4; SUP8; $I_{OH} = 6\text{ mA}$;					
		1.8 V mode	[1]	$V_{DD(I/O)} - 0.36$	-	-	V
		3.3 V mode	[1]	$V_{DD(I/O)} - 0.32$	-	-	V
		SUP3; $I_{OH} = 6\text{ mA}$		$V_{DD(I/O)} - 0.26$	-	-	V
		SUP3; $I_{OH} = 30\text{ mA}$		$V_{DD(I/O)} - 0.38$	-	-	V
V_{OL}	LOW-level output voltage	SUP4; SUP8 outputs; $I_{OL} = 4\text{ mA}$					
		1.8 V mode		-	-	0.2	V
		3.3 V mode	[1]	-	-	0.4	V
		SUP3; $I_{OL} = 4\text{ mA}$		-	-	0.4	V
I_{OH}	HIGH-level output current	$V_{DD(I/O)} = 1.8\text{ V}$; $V_{OH} = V_{DD} - 0.4\text{ V}$		1	-	-	mA
		$V_{DD(I/O)} = 3.3\text{ V}$; $V_{OH} = V_{DD} - 0.4\text{ V}$		2.5	-	-	mA
I_{OL}	LOW-level output current	$V_{DD(I/O)} = 1.8\text{ V}$; $V_{OL} = 0.4\text{ V}$		4.3	-	-	mA
		$V_{DD(I/O)} = 3.3\text{ V}$; $V_{OL} = 0.4\text{ V}$		6.2	-	-	mA
I_{OZ}	OFF-state output current	$V_O = 0\text{ V}$; $V_O = V_{DD}$; no pull-up/down		-	-	0.064	μA

Table 13: Static characteristics $T_{amb} = -40\text{ °C}$ to $+85\text{ °C}$ unless otherwise specified.

Symbol	Parameter	Conditions	Min	Typ	Max	Unit	
Z_o	output impedance	$V_{DD} = VDDE_IOx$ ($x = A, B, C$)					
		1.8 V mode	[1]	-	45	-	Ω
		3.3 V mode	[1]	-	35	-	Ω
I²C0-bus pins							
I_{OZ}	OFF-state output current	$V_O = 0\text{ V}; V_O = V_{DD};$ no pull-up/down	-	-	7.25	μA	
V_{IH}	HIGH-level input voltage		[1]	$0.7VDDE_IOC$	-	V	
V_{IL}	LOW-level input voltage		[1]	-	$0.3VDDE_IOC$	V	
V_{hys}	hysteresis voltage		$0.1VDDE_IOC$	-	-	V	
V_{OL}	LOW-level output voltage	$I_{OLS} = 3\text{ mA}$	-	-	0.298	V	
I_{LI}	input leakage current	VDDE voltage domain; $T_{amb} = 25\text{ °C}$	[1]	-	1.7	-	μA
		VDD voltage domain; $T_{amb} = 25\text{ °C}$	[1]	-	0.01	-	μA
USB							
V_{IC}	common-mode input voltage	high-speed mode	-50	200	500	mV	
		full-speed/low-speed mode	800	-	2500	mV	
		chirp mode	-50	-	600	mV	
$V_{i(dif)}$	differential input voltage		100	400	1100	mV	

[1] The parameter values specified are simulated values.

Table 14. Static characteristics of the 10-bit ADC

$V_{DD(ADC)} = 2.7\text{ V to }3.6\text{ V}$; $T_{amb} = -40\text{ °C to }+85\text{ °C}$ unless otherwise specified.

Symbol	Parameter	Conditions	Min	Typ	Max	Unit
V_{IA}	analog input voltage		0 ^[1]	-	$V_{DD(ADC)}$	V
$N_{res(ADC)}$	ADC resolution		2	-	10	bit
E_D	differential linearity error		^{[2][3][4]} -	-	± 1	LSB
$E_{L(adj)}$	integral non-linearity		^{[2][5]} -	-	± 1	LSB
$V_{err(O)}$	offset error voltage		-20	-	+20	mV

[1] On pin ADC10B_GNDA.

[2] Conditions: $V_{SSA} = 0\text{ V}$ on pin ADC10B_GNDA, $V_{DD(ADC)} = 3.3\text{ V}$.

[3] The ADC is monotonic, there are no missing codes.

[4] The differential linearity error (E_D) is the difference between the actual step width and the ideal step width. See [Figure 14](#).

[5] The integral non-linearity ($E_{L(adj)}$) is the peak difference between the center of the steps of the actual and the ideal transfer curve after appropriate adjustment of gain and offset errors. See [Figure 14](#).

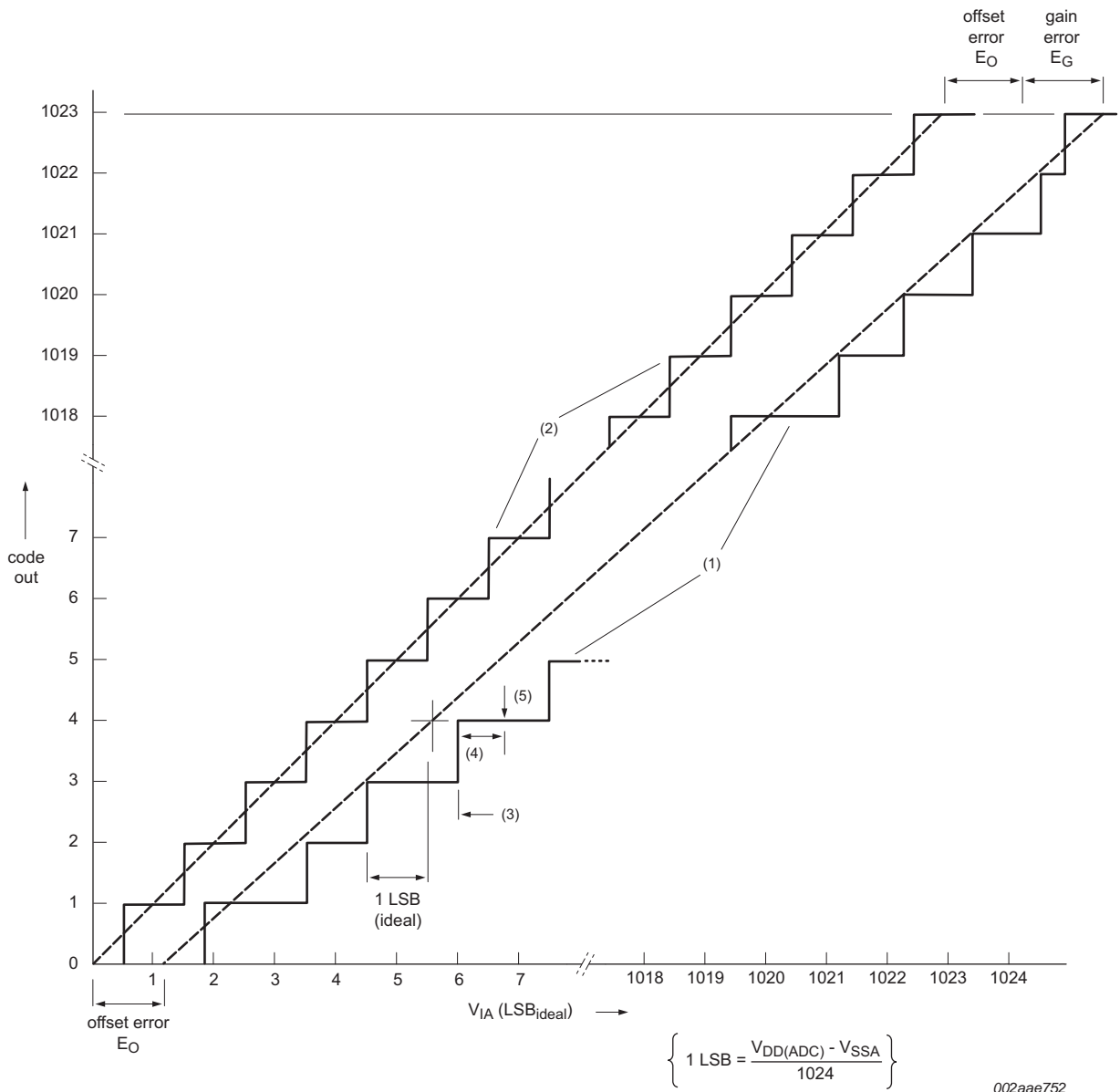

002aae752

- (1) Example of an actual transfer curve.
- (2) The ideal transfer curve.
- (3) Differential linearity error (E_D).
- (4) Integral non-linearity (E_{L(adj)}).
- (5) Center of a step of the actual transfer curve.

Fig 14. ADC characteristics

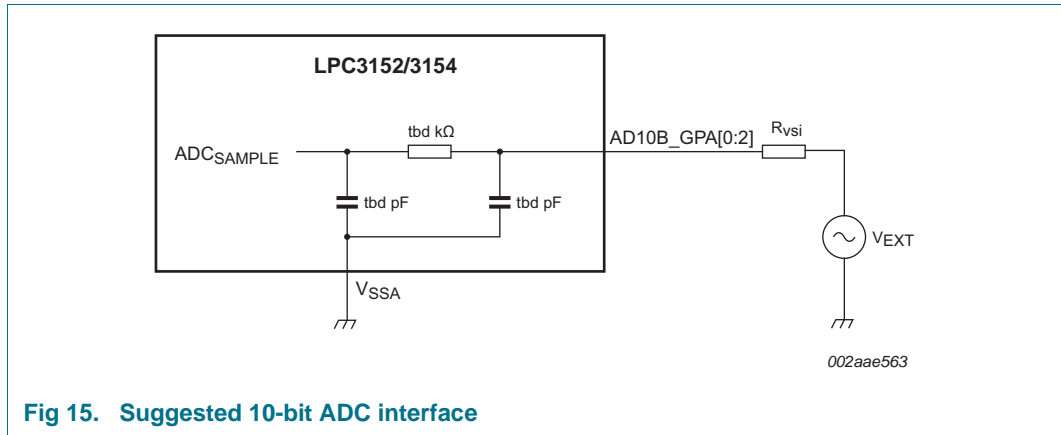

Fig 15. Suggested 10-bit ADC interface

9.2 Analog die

Table 15. Static characteristics of the analog die supply pins

$T_{amb} = -40\text{ }^{\circ}\text{C}$ to $+85\text{ }^{\circ}\text{C}$ unless otherwise specified.

Symbol	Parameter	Conditions	Min	Typ	Max	Unit
$V_{DD(I/O)}$	input/output supply voltage	peripheral supply of the analog die; SUP3	2.7	3.3	3.6	V
$V_{DD(CORE)}$	core supply voltage	core supply of the analog die; SUP2	1.3	1.4	1.95	V

9.2.1 PSU

Table 16: Static characteristics of the PSU

$T_{amb} = -40\text{ }^{\circ}\text{C}$ to $+85\text{ }^{\circ}\text{C}$ unless otherwise specified.

Symbol	Parameter	Conditions	Min	Typ	Max	Unit
$V_i(V_{BUS})$	V_{BUS} input voltage	on pin PSU_VBUS	4.0	5	5.5	V
V_{BAT}	battery supply voltage	on pin PSU_VBAT	2.7	3.7	4.2	V
output PSU_VOUT1						
$V_{O(DCDC1)}$	DC-to-DC converter 1 output voltage	generated from PSU_VBAT (programmable in 8 levels)	2.4	-	3.2	V
$V_{O(LDO1)}$	LDO1 output voltage	generated from PSU_VBUS	3.2	3.3	3.4	V
ΔV_o	output voltage variation	output voltage generated from PSU_VBAT [1]	-100	-	+100	mV
$I_{O(DCDC1)max}$	maximum DC-to-DC converter 1 output current	on pin PSU_VOUT1	-	-	350	mA
$I_{L(LDO1)max}$	maximum LDO load current	on LDO1	200	250	350	mA

Table 16: Static characteristics of the PSU ...continued

$T_{amb} = -40\text{ }^{\circ}\text{C}$ to $+85\text{ }^{\circ}\text{C}$ unless otherwise specified.

Symbol	Parameter	Conditions	Min	Typ	Max	Unit
output PSU_VOUT2						
$V_{O(DCDC2)}$	DC-to-DC converter 2 output voltage	generated from PSU_VBAT (programmable in 8 levels)	0.9	-	1.4	V
$V_{O(LDO2)}$	LDO2 output voltage	generated from PSU_VBUS (LDO1 on)	1.15	1.2	1.25	V
ΔV_o	output voltage variation	output voltage generated from PSU_VBAT ^[1]	-50	-	+50	mV
$I_{O(DCDC2)max}$	maximum DC-to-DC converter 2 output current	on pin PSU_VOUT2	-	-	250	mA
$I_{L(LDO)(max)}$	maximum LDO load current	on LDO2	80	-	120	mA
output PSU_VOUT3						
V_o	output voltage	generated from either PSU_VBAT or PSU_VBUS (programmable in 2 levels)	-	1.4	1.8	V
		on LDO3 of $V_o = 1.4\text{ V}$ (default)	1.35	1.4	1.45	V
		on LDO3 of $V_o = 1.8\text{ V}$ (default)	1.75	1.8	1.85	V
$I_{L(LDO)(max)}$	maximum LDO load current	on pin PSU_VOUT3	-	-	80	mA
DC-to-DC converter						
η_{DCDC}	DC-to-DC converter efficiency		-	85	-	%
f_{clk}	clock frequency		-	12	-	MHz
f_{osc}	oscillator frequency		8	10	12	MHz
f_{sw}	switching frequency		-	1	-	MHz

[1] Deviation of output voltage on pin PSU_VOUTn from its nominal, programmed value.

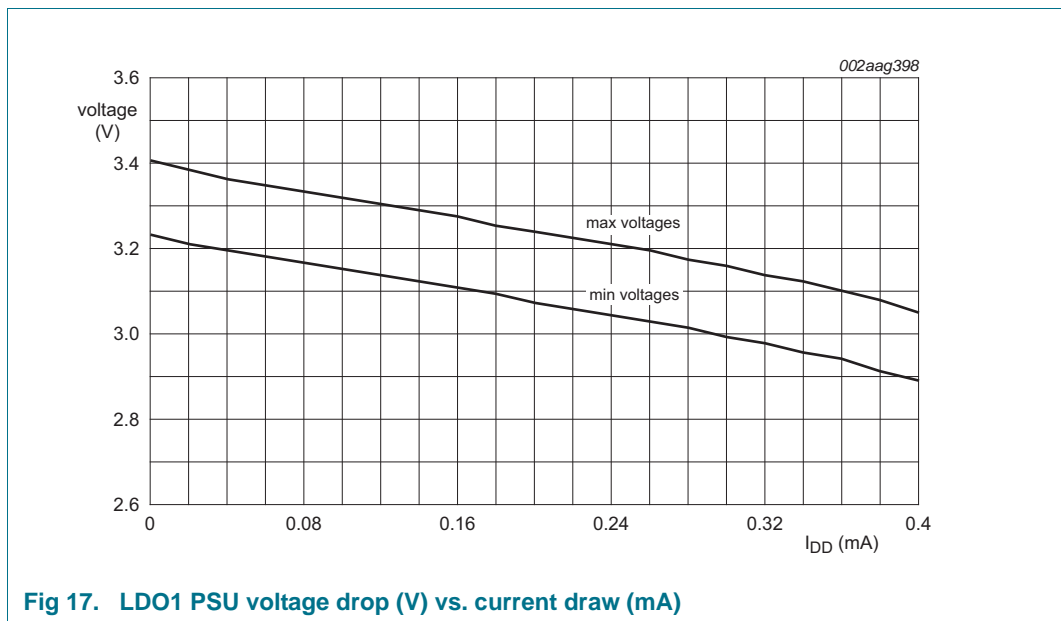
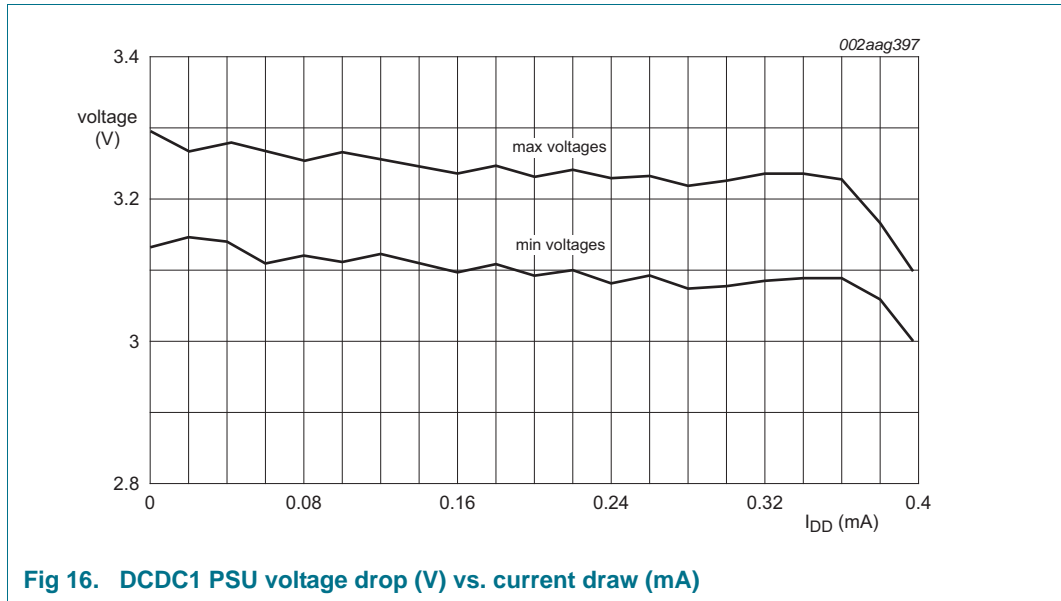

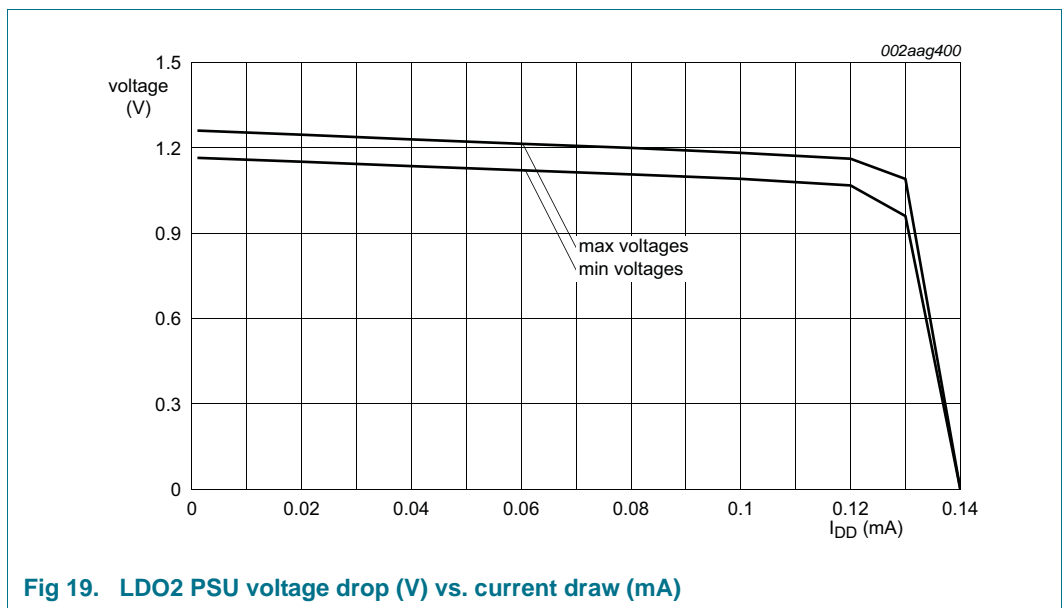
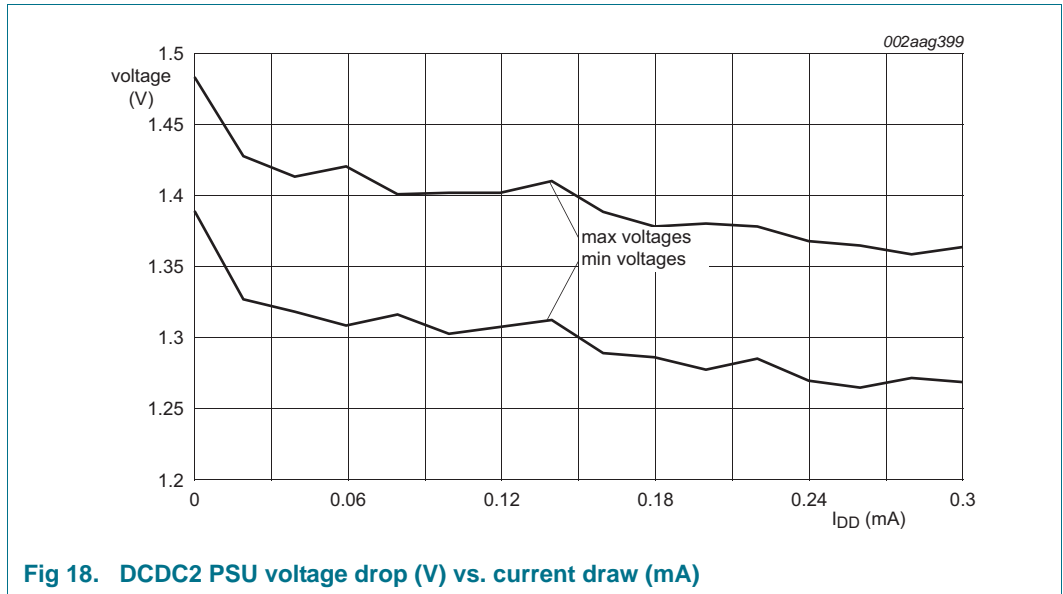

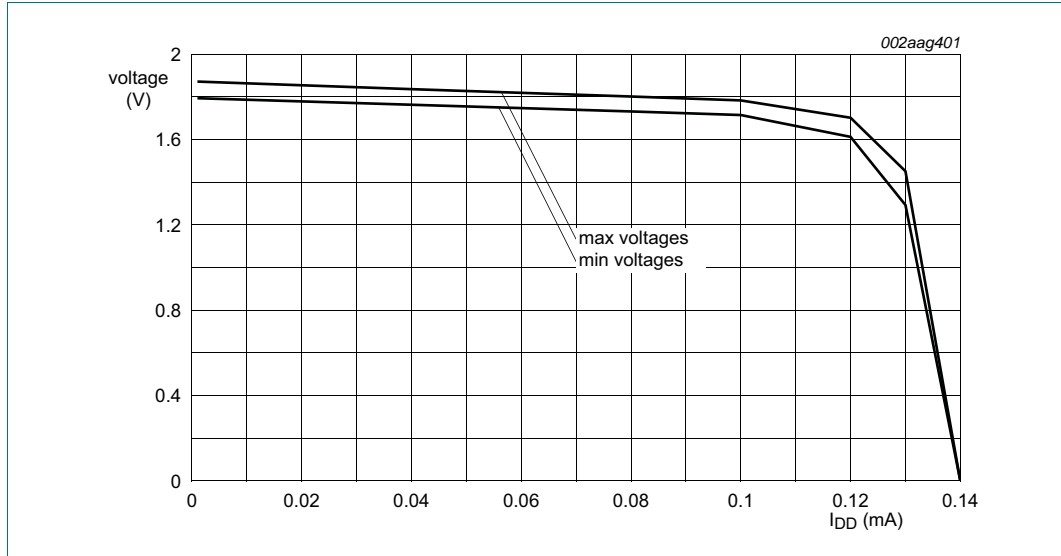

Fig 20. LDO3 PSU voltage drop (V) vs. current draw (mA), LDO3 @ 1.8 V

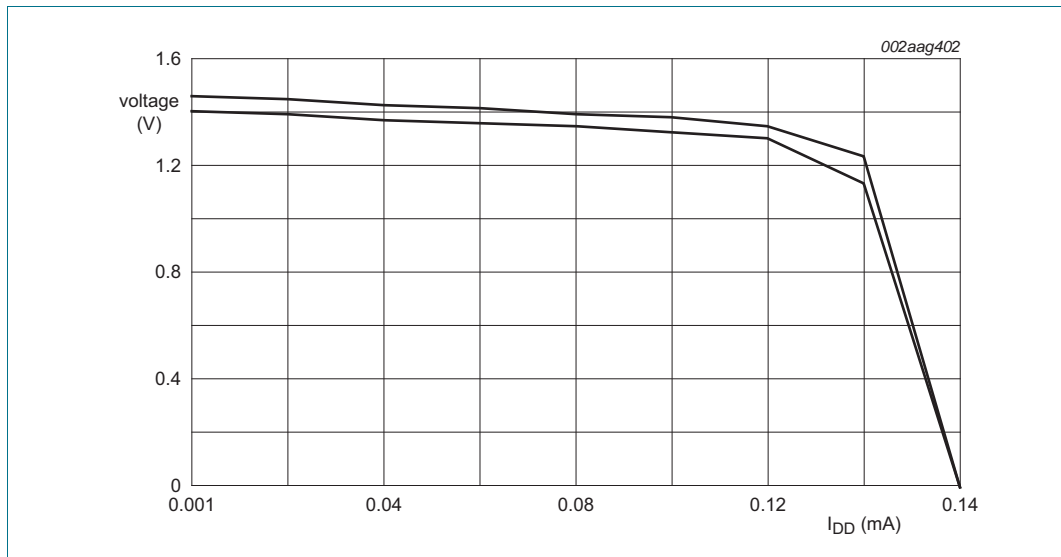

Fig 21. LDO3 PSU voltage drop (V) vs. current draw (mA), LDO3 @ 1.4 V

Table 17: Static characteristics of the analog input

$T_{amb} = -40\text{ }^{\circ}\text{C}$ to $+85\text{ }^{\circ}\text{C}$ unless otherwise specified.

Symbol	Parameter	Conditions	Min	Typ	Max	Unit
$I_{DDA(ADC)(3V3)}$	ADC analog supply current (3.3 V)	per mono ADC; normal operation	-	2.2	-	mA
$I_{DDA(ADC)(1V8)}$	ADC analog supply current (1.8 V)	per mono ADC; normal operation	-	-	20	μA
$I_{ref(neg)}$	negative reference current	per mono ADC; normal operation	-	20	-	μA
$I_{ref(pos)}$	positive reference current	per mono ADC; normal operation	-	20	-	μA
$I_{DDA(SDC)}$	SDC analog supply current		-	0.4	-	mA

Table 17: Static characteristics of the analog input

$T_{amb} = -40\text{ }^{\circ}\text{C}$ to $+85\text{ }^{\circ}\text{C}$ unless otherwise specified.

Symbol	Parameter	Conditions	Min	Typ	Max	Unit
$I_{DDA(PGA)}$	PGA analog supply current		-	430	-	μA
G_{PGA}	PGA gain		-	-1.94	-	dB
$I_{DDA(bias)}$	bias analog supply current	N = 13 for all modules on; normal operation	-	$190+N \times 10$	-	μA
$I_{DDA(LNA)}$	LNA analog supply current		-	0.85	1.2	mA
G_{LNA}	LNA gain	In a bandwidth between 300 Hz and 5 kHz.	28	30	32	dB
R_{ref}	reference resistance	headphone and DAC	-	11.25		k Ω
R_{com}	common resistance	headphone	-	11.25		k Ω
G	gain	step size 3 dB	0	-	24	dB

9.2.1.1 PSU_VOUT1 efficiency

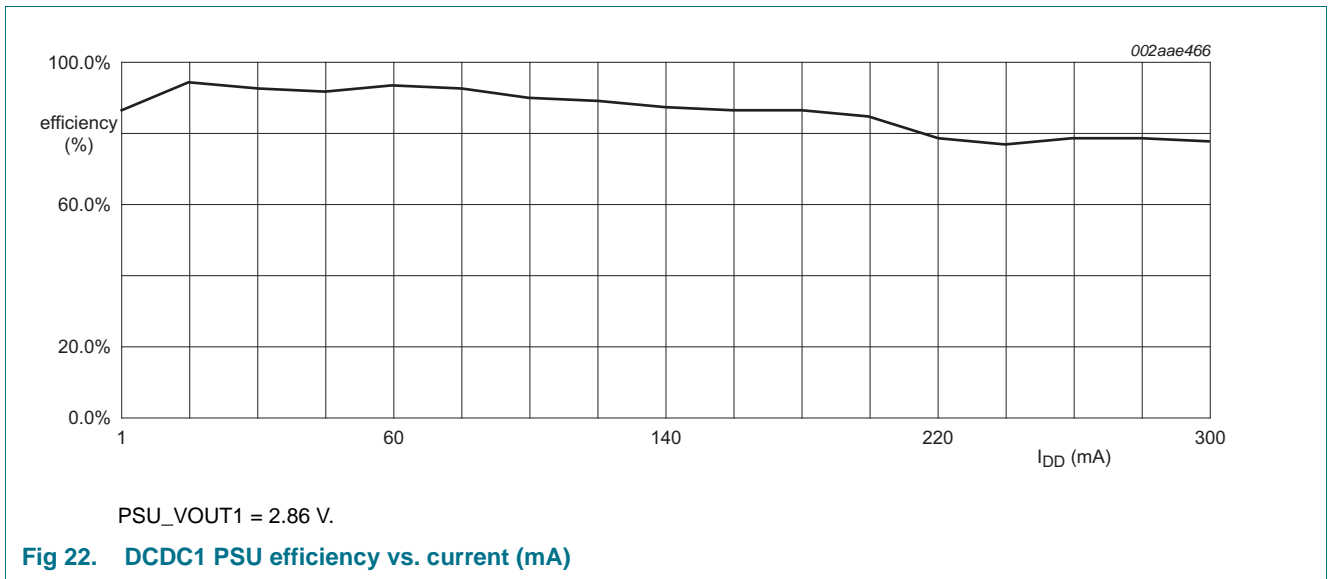

9.2.1.2 PSU_VOUT2 efficiency

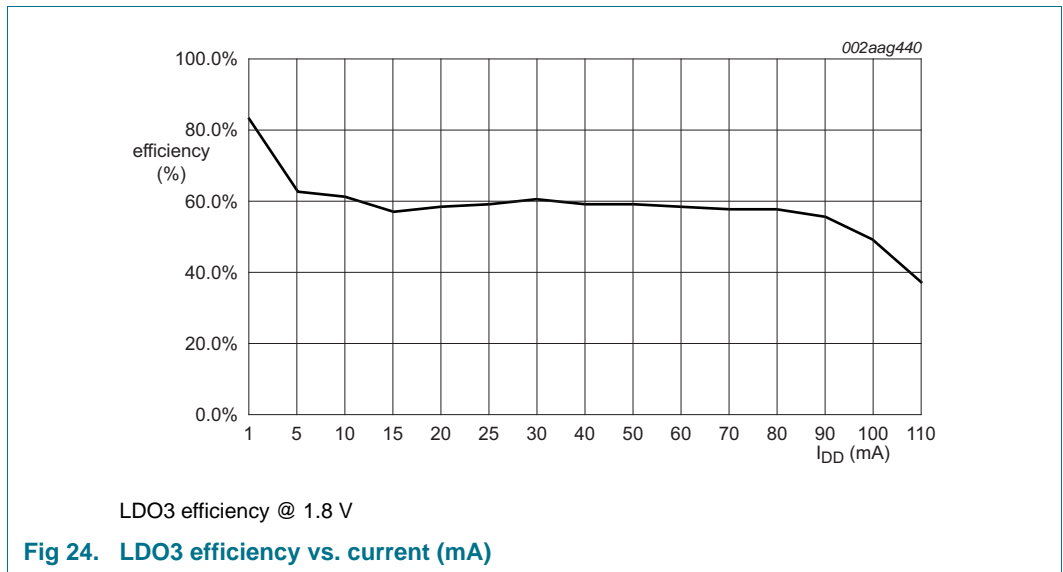
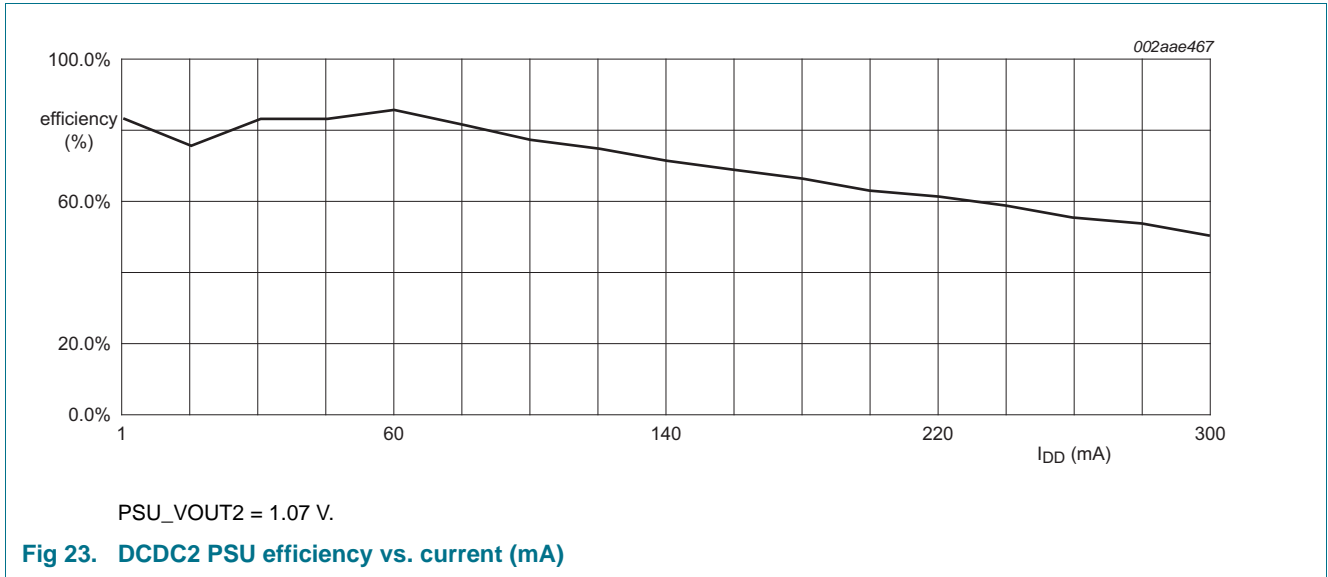

9.2.1.3 UOS_VBUS PSU efficiency

Table 18: Static characteristics of the USB PSU

$T_{amb} = -40\text{ }^{\circ}\text{C}$ to $+85\text{ }^{\circ}\text{C}$ unless otherwise specified.

Symbol	Parameter	Conditions	Min	Typ	Max	Unit
$V_{O(USB)}$	USB output voltage	generated from PSU_VBAT	4.3	5.0	5.1	V
$I_{O(USB)}$	USB output current	on pin UOS_VBUS	0	-	80	mA

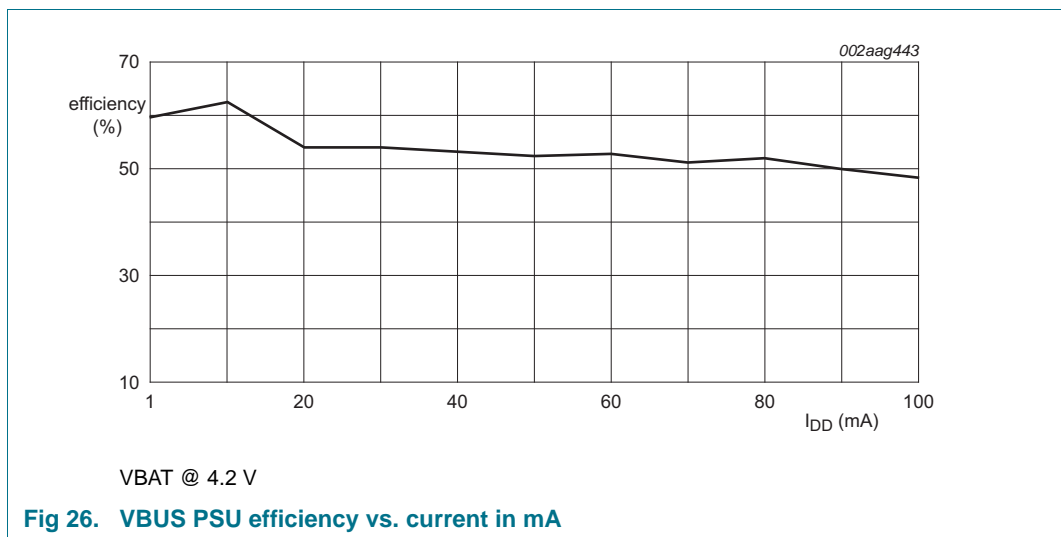
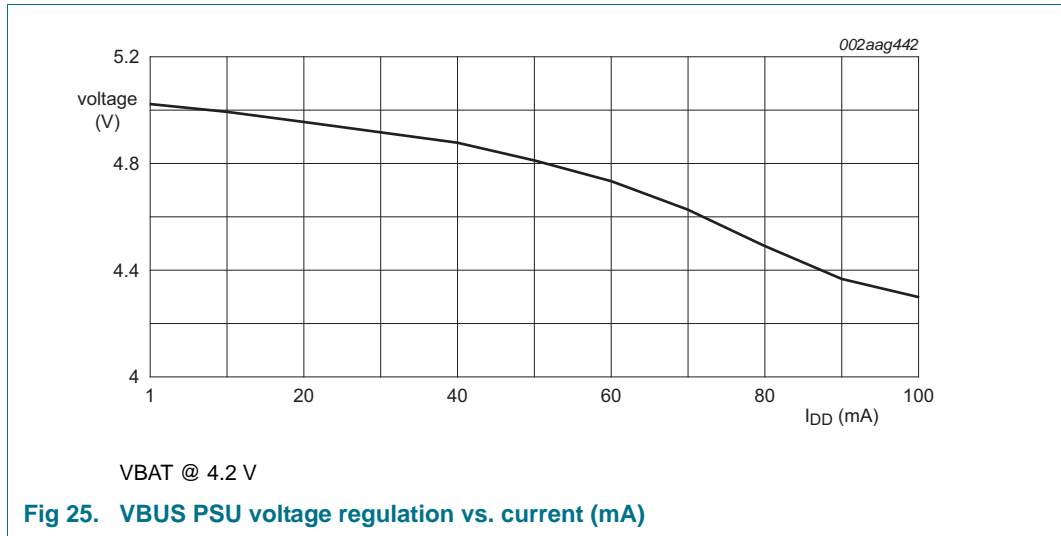

9.2.2 Li-ion charger

Table 19: Static characteristics of the Li-ion charger

Symbol	Parameter	Conditions	Min	Typ	Max	Unit
V_{bat}	battery voltage	cs_bits at 0000	-	-	4.25	V
I_{load}	load current	due to charger when 5 V is disconnected ^[1]	-	3	-	mA
constant-current charge (fast charge) mode						
I_{bat}	battery current	$R_{ext} = 1.00\text{ k}\Omega$	95	100	105	mA
		$R_{ext} = 400\Omega$	237.5	250	262.5	mA
trickle charge mode						
$V_{th(trch)bat}$	battery trickle charge threshold voltage	battery voltage rising	-	2.8	-	V
		battery voltage falling	-	2.7	-	V
constant-voltage charge mode						
$V_{th(cvch)bat}$	battery constant-voltage charge threshold voltage	After compensation using cs_bits	4.158	4.2	4.242	V
recharge mode						
$V_{th(rech)bat}$	battery recharge threshold voltage		-	4.05	-	V

[1] Reversed current spec: For $V_{bat} = 3.2\text{ V}$ (no USB and 100 k Ω to ground).

9.3 Power consumption

9.3.1 STOP mode power consumption

The LCP315x disables the internal PSUs when in STOP mode. This is the lowest power mode of the LCP315x, with the VBAT power supply providing power to maintain the internal RTC. Because the internal PSUs are not enabled, the only current draw is on VBAT and consists of RTC current and leakage current for other VBAT power rails.

Table 20. LPC315x VBAT power consumption in STOP mode

Signal/pin	Volts	Current			Unit	Power (max), μW
		Min ^[1]	Typ	Max ^[2]		
All other power rails	0	-	-	0	A	0
All VBAT inputs	3.5 to 4.2	-	-	10	μA	42
Total power					μW	42

[1] At minimum VBAT voltage, about 3.5 V.

[2] At minimum VBAT voltage, about 4.2 V.

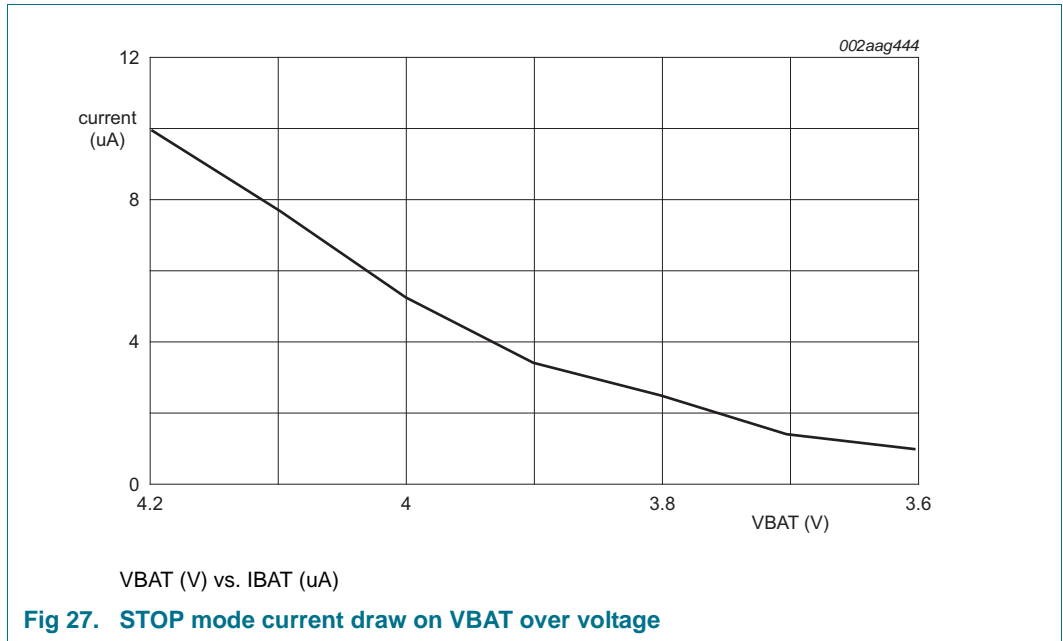

9.3.1.1 RTC_BACKUP pin power consumption

The RTC_BACKUP pin is used to provide power to the RTC on the analog die during normal system operation or in STOP mode. The power consumption values are given in the table and figure below for reference when picking the RTC backup capacitor.

Table 21. RTC_BACKUP current draw

Signal/pin	Max volts	Current			Unit	Power (max), μ W
		Min	Typ	Max		
RTC backup current	1.94	-	-	3.1	μ A	6.014

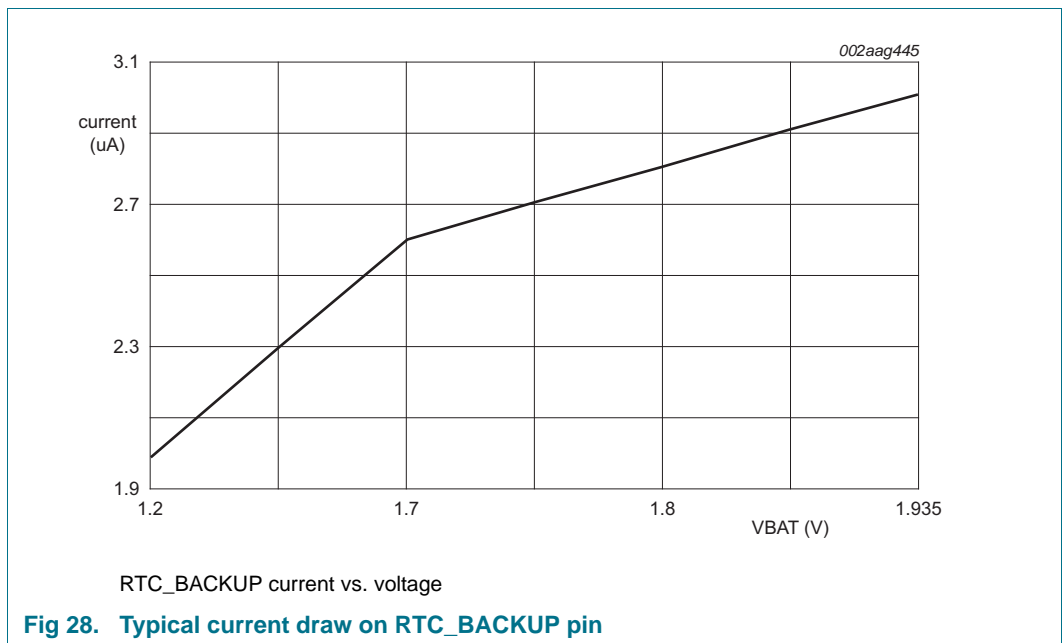

The following sections detail the power characteristics for different usage scenarios.

9.3.2 Standby mode power consumption

Standby mode is the lowest power mode of the chip which still maintains the CPU and system context. In standby mode the power rails need to be maintained, but most of the clocks are disabled. While in standby mode, events such as GPIO state changes or incoming UART data can be used to wake up the device. The advantage of standby mode over stop mode is that the device will wake up with its existing context preserved and continue working without a lengthy system boot-up and initialization process. However, standby mode uses more power than stop mode.

9.3.3 Typical and maximum power consumption based on scenario

In this section, the LPC315x power consumption for various scenarios is shown.

Maximum power consumption numbers show power usage when the chip power rails are maintained at the maximum voltage limit and are not typical of a real system's power usage. Maximum power consumption numbers use voltages that cannot be obtained by the LPC315x internal power supplies and only indicate maximum draw of the chip under maximum voltage conditions. The maximum power usage sets up the core voltage rail at 1.3 V, the IO voltage rail at 3.6 V, and the analog die voltage rail at 1.95 V. These are the maximum limits that the chip can handle. The maximum power consumption is presented for the Linux full load scenario.

Typical power consumption numbers use the LPC315x internal power supplies and programmed internal power supply voltages that don't approach the maximum voltage limits. Typical power numbers are considerably lower than the maximum power numbers and are more indicative of what an actual system and scenario would consume for power. The typical power usage sets the internal power supply voltages as follows: core voltage at 1.19 V, IO voltage at 3.2 V, analog die voltage at 1.8 V or 1.4 V.

All numbers are at an ambient air temperature of 25 °C.

9.3.3.1 Summary of power consumption scenarios

The following table summarizes the total power for each scenario presented. Detailed breakdowns of the voltages, currents, and power per rail are presented in subsequent sections.

Table 22. RTC_BACKUP current draw

Scenario	MMU on/off	Dynamic clocking on/off	Total power (mW) ^[1]
System standby mode	n/a	n/a	17.74365
Dhrystone test running in IRAM	on	off	129.92808
Dhrystone test running in IRAM	off	off	114.94308
Running Linux, idle at the console prompt	on	off	156.2125
Running Linux, idle at the console prompt	on	on	105.28298
Running Linux, full load	on	off	260.5264
Running Linux, full load	on	on	189.4872

Table 22. RTC_BACKUP current draw ...continued

Scenario	MMU on/off	Dynamic clocking on/off	Total power (mW) ^[1]
Running Linux, full load	on	off	345.5107 ^[2]
Running Linux, full load	on	on	251.6657 ^[2]
Built-in audio tests	n/a	n/a	295.6209

[1] Typical voltages using internal PSU unless otherwise stated, and ADC_VDDA18 and VDDI_3/VDDI_AD set to 1.8 V. The analog die can set the voltage for these rails at 1.4 V or 1.8 V. See breakdown tables below for each scenario for 1.4 V information.

[2] Maximum power using external power supplies. Maximum power consumption numbers use voltages that cannot be obtained by the LPC315x internal power supplies and only indicate maximum draw of the chip under maximum voltage conditions.

9.3.3.2 System standby mode

In system standby mode, the system is powered on and a program is executed to place the system into its lowest power standby state. All functions on the analog die are disabled. This is the lowest power system mode without placing the LPC315x into STOP mode.

Table 23. System standby mode typical power consumption using internal PSU

Signal/pin	Typ volts	Typ current (mA)	Typ power (mW)
VDDA12	1.19	0.19	0.2261
ADC10B_VDDA33	3.2	0.0005	0.0016
ADC_VDDA18 (1.8 V) ^[1]	1.8	0.0004	0.00072
ADC_VDDA33	3.2	0.0014	0.00448
DAC_VDDA33	3.2	0.0266	0.08512
HP_VDDA33	3.2	0.15	0.48
USB_VDDA12_PLL	1.19	0.0006	0.000714
USB_VDDA33_DRV	3.2	0.888	2.8416
USB_VDDA33	3.2	1.491	4.7712
VDDI_0/1/2	1.19	2.1728	2.585632
VDDI_3/VDDI_AD (1.8 V) ^[1]	1.8	.0223	0.04014
VDDE_IOA	3.2	1.68	5.376
VDDE_IOB	3.2	0.0016	0.00512
VDDE_IOC	3.2	0.301	0.9632
VDDE_IOD	3.2	0.0896	0.28672
VPP	1.19	0.0001	0.000119
RTC_VDD36	4.2	0.006	0.0252
UOS_VBAT	4.2	0.0029	0.01218
CHARGE_VBAT	4.2	0.009	0.0378
Total power		1.68	17.74365

[1] The analog die can set the voltage for this rail at 1.4 V or 1.8 V. Setting this power rail to 1.4 V instead of 1.8 V can further reduce power by about 17 μW.

9.3.3.3 Dhrystone tests in IRAM with MMU, no dynamic clocking

These power measurements are performed while running the Dhrystone test at 180/90 MHz with the MMU on from internal RAM. Dynamic clock scaling is disabled, but all analog die functions are enabled and powered up. The caches are enabled.

Table 24. Dhrystone tests in IRAM with MMU, no dynamic clocking, typical power consumption using internal PSU

Signal/pin	Typ volts	Typ current (mA)	Typ power (mW)
VDDA12	1.19	1.66	1.9754
ADC10B_VDDA33	3.2	0.0005	0.0016
ADC_VDDA18 (1.8 V) ^[1]	1.8	0.0003	0.00054
ADC_VDDA33	3.2	7.65	24.48
DAC_VDDA33	3.2	0.89	2.848
HP_VDDA33	3.2	3	9.6
USB_VDDA12_PLL	1.19	0.0005	0.000595
USB_VDDA33_DRV	3.2	0.895	2.864
USB_VDDA33	3.2	1.56	4.992
VDDI_0/1/2	1.19	41.42	49.2898
VDDI_3/VDDI_AD (1.8 V) ^[1]	1.8	1.85	3.33
VDDE_IOA ^[2]	3.2	9	28.8
VDDE_IOB ^[2]	3.2	0.0015	0.0048
VDDE_IOC	3.2	0.432	1.3824
VDDE_IOD	3.2	0.0885	0.2832
VPP	1.19	0.0001	0.000119
RTC_VDD36	4.2	0.006	0.0252
UOS_VBAT	4.2	0.0033	0.01386
CHARGE_VBAT	4.2	0.0087	0.03654
Total power			129.92808

[1] The analog die can set the voltage for this rail at 1.4 V or 1.8 V. Setting this power rail to 1.4 V instead of 1.8 V can further reduce power by about 1.44 mW.

[2] An estimated power savings of an additional 25 mW is possible on a 1.8 V system.

9.3.3.4 Dhrystone tests in IRAM with MMU off, no dynamic clocking

These power measurements are performed while running the Dhrystone test at 180/90 MHz with the MMU off from internal RAM. Dynamic clock scaling is disabled, but all analog die functions are enabled and powered up.

Table 25. Dhrystone tests in IRAM, MMU off, no dynamic clocking, typical power consumption using internal PSU

Signal/pin	Typ volts	Typ current (mA)	Typ power (mW)
VDDA12	1.19	1.66	1.9754
ADC10B_VDDA33	3.2	0.0004	0.00128
ADC_VDDA18 (1.8 V) ^[1]	1.8	0.0002	0.00036
ADC_VDDA33	3.2	7.56	24.192
DAC_VDDA33	3.2	0.87	2.784
HP_VDDA33	3.2	3	9.6

Table 25. Dhystone tests in IRAM, MMU off, no dynamic clocking, typical power consumption using internal PSU ...continued

Signal/pin	Typ volts	Typ current (mA)	Typ power (mW)
USB_VDDA12_PLL	1.19	0.0005	0.000595
USB_VDDA33_DRV	3.2	0.893	2.8576
USB_VDDA33	3.2	1.54	4.928
VDDI_0/1/2	1.19	26.59	31.6421
VDDI_3/VDDI_AD (1.8 V) ^[1]	1.8	1.8	3.24
VDDE_IOA ^[2]	3.2	10	32
VDDE_IOB ^[2]	3.2	0.0006	0.00192
VDDE_IOC	3.2	0.428	1.3696
VDDE_IOD	3.2	0.0859	0.27488
VPP	1.19	0.0001	0.000119
RTC_VDD36	4.2	0.006	0.0252
UOS_VBAT	4.2	0.0033	0.01386
CHARGE_VBAT	4.2	0.0086	0.03612
Total power			114.94308

[1] The analog die can set the voltage for this rail at 1.4 V or 1.8 V. Setting this power rail to 1.4 V instead of 1.8 V can further reduce power by about 1.44 mW.

[2] An estimated power savings of an additional 30 mW is possible on a 1.8 V system.

9.3.3.5 Linux idle at console prompt

These power measurements are performed while running Linux at 180/90MHz from SDRAM. All analog die functions are enabled and powered up. Linux is sitting idle waiting at the console prompt. Power measurements are provided for systems with and without dynamic clocking enabled.

Table 26. Linux console with dynamic clocking typical power consumption using internal PSU

Signal/pin	Max volts	With dynamic clocking enabled		Dynamic clocking not enabled	
		Typ current (mA)	Typ power (mW)	Typ current (mA)	Typ power (mW)
VDDA12	1.19	1.204	1.43276	1.97	2.3443
ADC10B_VDDA33	3.2	0.0006	0.00192	0.0005	0.0016
ADC_VDDA18 (1.8 V) ^[1]	1.8	0.0004	0.00072	0.0082	0.01476
ADC_VDDA33	3.2	7.72	24.704	8.13	26.016
DAC_VDDA33	3.2	0.889	2.8448	2.17	6.944
HP_VDDA33	3.2	2.47	7.904	2.48	7.936
USB_VDDA12_PLL	1.19	0.0001	0.000119	0.0005	0.000595
USB_VDDA33_DRV	3.2	0.892	2.8544	0.893	2.8576
USB_VDDA33	3.2	1.58	5.056	1.57	5.024
VDDI_0/1/2	1.19	22.72	27.0368	35.72	42.5068
VDDI_3/VDDI_AD (1.8 V) ^[1]	1.8	8.68	15.624	8.78	15.804
VDDE_IOA ^[2]	3.2	0.6	1.92	0.59	1.888

Table 26. Linux console with dynamic clocking typical power consumption using internal PSU

Signal/pin	Max volts	With dynamic clocking enabled		Dynamic clocking not enabled	
		Typ current (mA)	Typ power (mW)	Typ current (mA)	Typ power (mW)
VDDE_IOB ^[2]	3.2	0.834	2.6688	10.94	35.008
VDDE_IOC	3.2	4.02	12.864	2.96	9.472
VDDE_IOD	3.2	0.094	0.3008	0.0992	0.31744
VPP	1.19	0.0001	0.000119	0.0001	0.000119
RTC_VDD36	4.2	0.006	0.0252	0.006	0.0252
UOS_VBAT	4.2	0.0027	0.01134	0.0037	0.01554
CHARGE_VBAT	4.2	0.0079	0.03318	0.0087	0.03654
Total power			105.28298		156.2125

[1] The analog die can set the voltage for this rail at 1.4 V or 1.8 V. Setting this power rail to 1.4 V instead of 1.8 V can further reduce power by about 7.5 mW.

[2] An estimated power savings of an additional 20 mW is possible on a 1.8 V system.

9.3.3.6 Linux running full load

These power measurements are performed while running Linux at 180/90 MHz from SDRAM. All analog die functions are enabled and powered up. Linux is running at 100 % full load with a mixture of memory tests, NAND read/write operations, and SD card read/write operations. Power measurements are provided for systems with and without dynamic clocking enabled.

Table 27. Linux full load maximum power consumption using external power supplies^[1]

Signal/pin	Max volts ^[1]	With dynamic clocking enabled		Dynamic clocking not enabled	
		Max current (mA)	Max power ^[1] (mW)	Max current (mA)	Max power ^[1] (mW)
VDDA12	1.3	2.34	3.042	2.34	3.042
ADC10B_VDDA33	3.6	0.0006	0.00216	0.0005	0.0018
ADC_VDDA18	1.95	0.0002	0.00039	0.0086	0.01677
ADC_VDDA33	3.6	8.67	31.212	9.33	33.588
DAC_VDDA33	3.6	1.17	4.212	2.3	8.28
HP_VDDA33	3.6	2.58	9.288	2.59	9.324
USB_VDDA12_PLL	1.3	0.0006	0.00078	0.0006	0.00078
USB_VDDA33_DRV	3.6	0.896	3.2256	0.895	3.222
USB_VDDA33	3.6	1.76	6.336	1.77	6.372
VDDI_0/1/2	1.3	58.11	75.543	69.34	90.142
VDDI_3/VDDI_AD	1.95	10.12	19.734	10.56	20.592
VDDE_IOA	3.6	9.2	33.12	24.36	87.696
VDDE_IOB	3.6	13.68	49.248	18.4	66.24
VDDE_IOC	3.6	4.47	16.092	4.46	16.056
VDDE_IOD	3.6	0.16	0.576	0.251	0.9036

Table 27. Linux full load maximum power consumption using external power supplies^[1]

Signal/pin	Max volts ^[1]	With dynamic clocking enabled		Dynamic clocking not enabled	
		Max current (mA)	Max power ^[1] (mW)	Max current (mA)	Max power ^[1] (mW)
VPP	1.3	0.0001	0.00013	0.0001	0.00013
RTC_VDD36	4.2	0.006	0.0252	0.006	0.0252
Other VBAT inputs	4.2	0.002	0.0084	0.002	0.0084
Total power			251.6657		345.5107

[1] Maximum power consumption numbers use voltages that cannot be obtained by the LPC315x internal power supplies and only indicate maximum draw of the chip under maximum voltage conditions.

Table 28. Linux full load typical power consumption using internal PSU

Signal/pin	Typ volts	With dynamic clocking enabled		Dynamic clocking not enabled	
		Typ current (mA)	Typ power (mW)	Typ current (mA)	Typ power (mW)
VDDA12	1.19	2.27	2.7013	2.27	2.7013
ADC10B_VDDA33	3.2	0.0009	0.00288	0.0006	0.00192
ADC_VDDA18 (1.8 V) ^[1]	1.8	0.0005	0.0009	0.0082	0.01476
ADC_VDDA33	3.2	7.64	24.448	8.13	26.016
DAC_VDDA33	3.2	0.889	2.8448	2.17	6.944
HP_VDDA33	3.2	2.47	7.904	2.48	7.936
USB_VDDA12_PLL	1.19	0.0001	0.000119	0.0005	0.000595
USB_VDDA33_DRV	3.2	0.892	2.8544	0.893	2.8576
USB_VDDA33	3.2	1.58	5.056	1.57	5.024
VDDI_0/1/2	1.19	51.98	61.8562	61.63	73.3397
VDDI_3/VDDI_AD (1.8 V) ^[1]	1.8	8.68	15.624	8.75	15.75
VDDE_IOA ^[2]	3.2	7	22.4	18.4	58.88
VDDE_IOB ^[2]	3.2	9.55	30.56	15	48
VDDE_IOC	3.2	4.02	12.864	3.96	12.672
VDDE_IOD	3.2	0.094	0.3008	0.0971	0.31072
VPP	1.19	0.0001	0.000119	0.0001	0.000119
RTC_VDD36	4.2	0.006	0.0252	0.006	0.0252
UOS_VBAT	4.2	0.0027	0.01134	0.0037	0.01554
CHARGE_VBAT	4.2	0.0079	0.03318	0.0088	0.03696
Total power			189.4872		260.5264

[1] The analog die can set the voltage for this rail at 1.4 V or 1.8 V. Setting this power rail to 1.4 V instead of 1.8 V can further reduce power by about 7.36 mW.

[2] An estimated power savings of an additional 37 mW is possible on a 1.8 V system when using dynamic clocking or 74 mW when not using dynamic clocking.

9.3.3.7 Built-in audio tests

These power measurements are performed using the built-in audio tests of the LPC315x boot ROM. In these tests, the analog die functions related to audio are placed under load. The built-in audio tests setup the internal power supplies during the tests for typical power testing.

Table 29. Built-in audio tests typical power consumption

Signal/pin	Typ volts	Typ current (mA)	Typ power (mW)
VDDA12	1.19	1.95	2.02605
ADC10B_VDDA33	3.2	0.0007	0.00196
ADC_VDDA18 (1.4 V)	1.4	0.0023	0.00322
ADC_VDDA33	3.2	7.53	21.084
DAC_VDDA33	3.2	0.665	1.862
HP_VDDA33	3.2	2.72	7.616
USB_VDDA12_PLL	1.19	0.002	0.002078
USB_VDDA33_DRV	3.2	0.895	2.506
USB_VDDA33	3.2	1.54	4.312
VDDI_0/1/2	1.19	28.13	29.22707
VDDI_3/VDDI_AD (1.4 V)	1.4	3.11	4.354
VDDE_IOA	3.2	6	16.8
VDDE_IOB	3.2	0.0014	0.00392
VDDE_IOC	3.2	3.48	9.744
VDDE_IOD	3.2	70	196
VPP	1.19	0.0001	0.000104
RTC_VDD36	4.2	0.006	0.0252
UOS_VBAT	4.2	0.0036	0.01512
CHARGE_VBAT	4.2	0.0091	0.03822
Total power			295.6209

10. Dynamic characteristics

10.1 Digital die

10.1.1 LCD controller

10.1.1.1 Intel 8080 mode

Table 30. Dynamic characteristics: LCD controller in Intel 8080 mode

$C_L = 25\text{ pF}$, $T_{amb} = -40\text{ }^\circ\text{C}$ to $+85\text{ }^\circ\text{C}$, unless otherwise specified; $V_{DD(I/O)} = 1.8\text{ V}$ and 3.3 V (SUP8) .

Symbol	Parameter	Conditions	Min	Typ	Max	Unit
$t_{su(A)}$	address set-up time		-	$1 \times \text{LCDCLK}$	-	ns
$t_{h(A)}$	address hold time		-	$2 \times \text{LCDCLK}$	-	ns
$t_{cy(a)}$	access cycle time	[1]	-	$5 \times \text{LCDCLK}$	-	ns
$t_{w(en)W}$	write enable pulse width	[1]	-	$2 \times \text{LCDCLK}$	-	ns
$t_{w(en)R}$	read enable pulse width	[1]	-	$2 \times \text{LCDCLK}$	-	ns
t_r	rise time		2	-	5	ns
t_f	fall time		2	-	5	ns
$t_{d(QV)}$	data output valid delay time		-	$-1 \times \text{LCDCLK}$	-	ns
$t_{dis(Q)}$	data output disable time		-	$2 \times \text{LCDCLK}$	-	ns

[1] Timing is determined by the LCD Interface Control Register fields: $\text{INVERT_CS} = 1$; $\text{MI} = 0$; $\text{PS} = 0$; $\text{INVERT_E_RD} = 0$. See the *LPC315x user manual*.

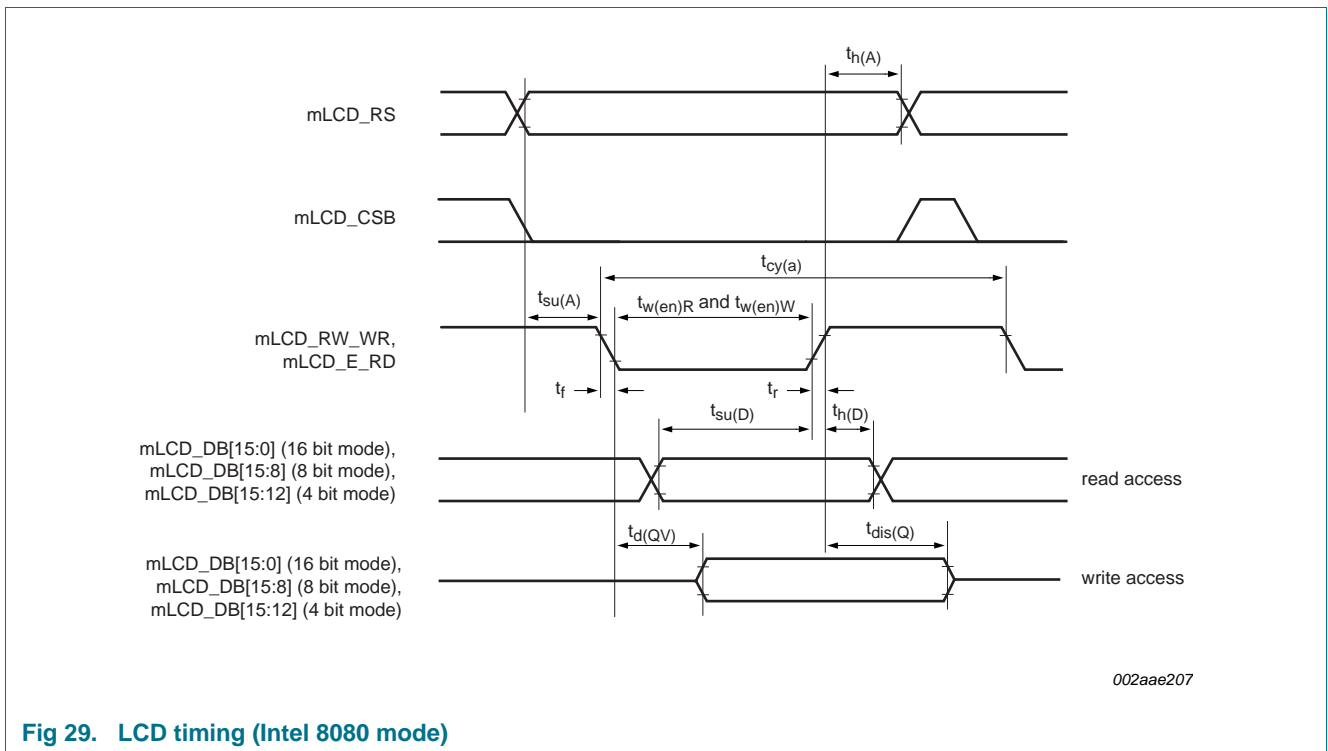

Fig 29. LCD timing (Intel 8080 mode)

10.1.1.2 Motorola 6800 mode

Table 31. Dynamic characteristics: LCD controller in Motorola 6800 mode

$C_L = 25\text{ pF}$, $T_{amb} = -40\text{ }^\circ\text{C}$ to $+85\text{ }^\circ\text{C}$, unless otherwise specified; $V_{DD(I/O)} = 1.8\text{ V}$ and 3.3 V (SUP8) .

Symbol	Parameter	Conditions	Min	Typ	Max	Unit
$t_{su(A)}$	address set-up time		-	$1 \times \text{LCDCLK}$	-	ns
$t_{h(A)}$	address hold time		-	$2 \times \text{LCDCLK}$	-	ns
$t_{cy(a)}$	access cycle time		[1]	$5 \times \text{LCDCLK}$	-	ns
t_r	rise time		2	-	5	ns
t_f	fall time		2	-	5	ns
$t_{d(QV)}$	data output valid delay time		-	$-1 \times \text{LCDCLK}$	-	ns
$t_{dis(Q)}$	data output disable time		-	$2 \times \text{LCDCLK}$	-	ns
$t_{w(en)}$	enable pulse width	read cycle	-	$2 \times \text{LCDCLK}$	-	ns
		write cycle	-	$2 \times \text{LCDCLK}$	-	ns

[1] Timing is derived from the LCD Interface Control Register fields: $\text{INVERT_CS} = 1$; $\text{MI} = 1$; $\text{PS} = 0$; $\text{INVERT_E_RD} = 0$. See the *LPC315x user manual*.

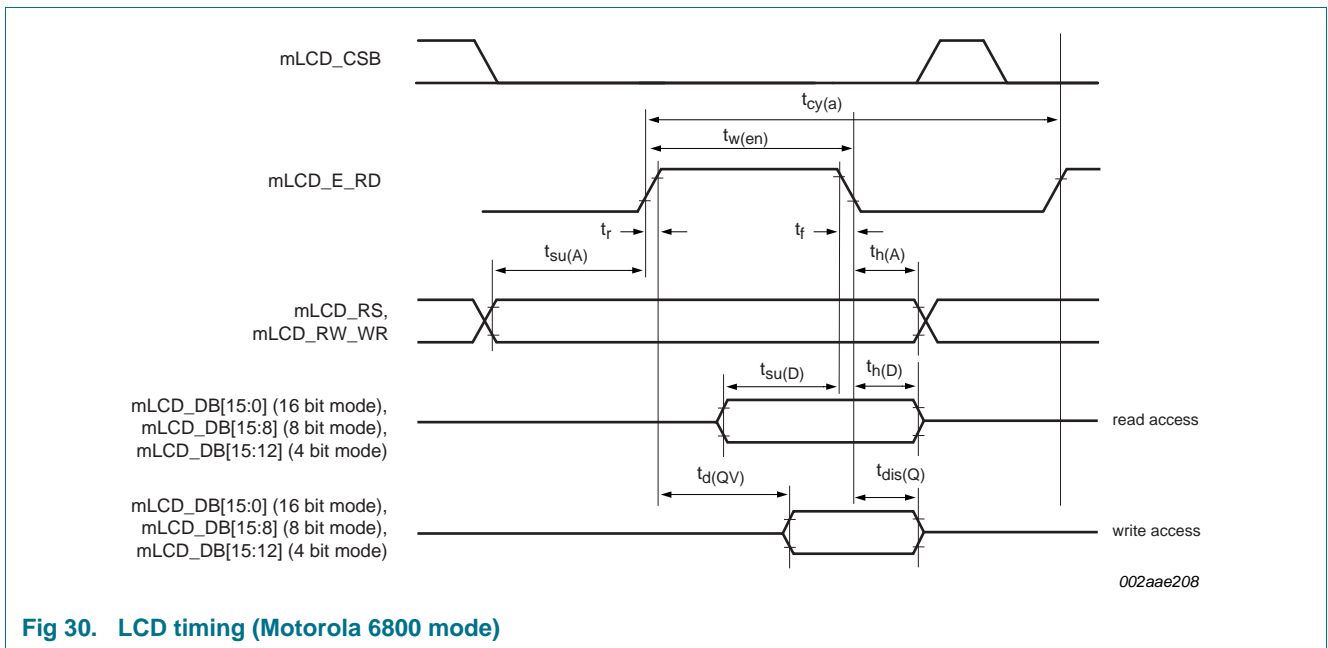

Fig 30. LCD timing (Motorola 6800 mode)

10.1.1.3 Serial mode

Table 32. Dynamic characteristics: LCD controller serial mode

$C_L = 25\text{ pF}$, $T_{amb} = -40\text{ }^\circ\text{C}$ to $+85\text{ }^\circ\text{C}$, unless otherwise specified; $V_{DD(I/O)} = 1.8\text{ V}$ and 3.3 V (SUP8).

Symbol	Parameter	Conditions	Min	Typ	Max	Unit
$T_{cy}(\text{clk})$	clock cycle time		[1]	$5 \times \text{LCDCLK}$	-	ns
$t_{w(\text{clk})H}$	HIGH clock pulse width		[1]	$3 \times \text{LCDCLK}$	-	ns
$t_{w(\text{clk})L}$	LOW clock pulse width		[1]	$2 \times \text{LCDCLK}$	-	ns
t_r	rise time		2	-	5	ns
t_f	fall time		2	-	5	ns
$t_{su(A)}$	address set-up time		-	$3 \times \text{LCDCLK}$	-	ns
$t_{h(A)}$	address hold time		-	$2 \times \text{LCDCLK}$	-	ns
$t_{su(S)}$	chip select set-up time		-	$3 \times \text{LCDCLK}$	-	ns
$t_{h(S)}$	chip select hold time		-	$1 \times \text{LCDCLK}$	-	ns
$t_{d(QV)}$	data output valid delay time		-	$-1 \times \text{LCDCLK}$	-	ns

[1] Timing is determined by the LCD Interface Control Register fields: PS = 1; SERIAL_CLK_SHIFT = 3; SERIAL_READ_POS = 3. See the LPC315x user manual.

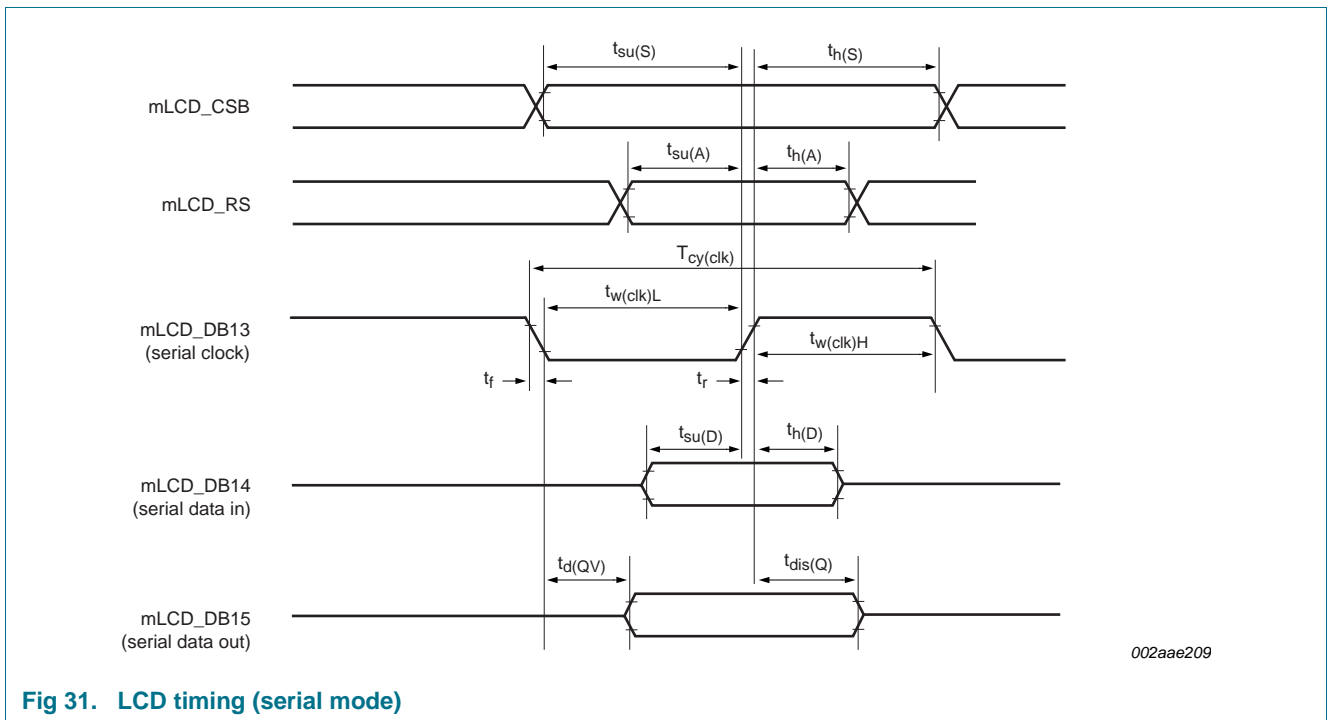

Fig 31. LCD timing (serial mode)

002aae209

10.1.2 SRAM controller

Table 33. Dynamic characteristics: static external memory interface

$C_L = 25\text{ pF}$, $T_{amb} = -40\text{ °C to }+85\text{ °C}$, unless otherwise specified; $V_{DD(I/O)} = 1.8\text{ V and }3.3\text{ V (SUP8)}$.

Symbol	Parameter	Conditions	Min	Typ	Max	Unit
Common to read and write cycles						
t _{CSLAV}	$\overline{\text{CS}}$ LOW to address valid time		-1.8	0	4	ns
Read cycle parameters						
t _{OELAV}	$\overline{\text{OE}}$ LOW to address valid time	[1][2]	-	0 – WAITOEN × HCLK	-	ns
t _{BLSLAV}	$\overline{\text{BLS}}$ LOW to address valid time	[1][2]	-	0 – WAITOEN × HCLK	-	ns
t _{CSLOEL}	$\overline{\text{CS}}$ LOW to $\overline{\text{OE}}$ LOW time	[3][4]	-	0 + WAITOEN × HCLK	-	ns
t _{CSLBLSL}	$\overline{\text{CS}}$ LOW to $\overline{\text{BLS}}$ LOW time	[1][5]	-	0 + WAITOEN × HCLK	-	ns
t _{OELOEH}	$\overline{\text{OE}}$ LOW to $\overline{\text{OE}}$ HIGH time	[1][6][7] [12]	-	(WAITRD – WAITOEN + 1) × HCLK	-	ns
t _{BLSLBLSH}	$\overline{\text{BLS}}$ LOW to $\overline{\text{BLS}}$ HIGH time	[1][7] [12]	-	(WAITRD – WAITOEN + 1) × HCLK	-	ns
t _{su(D)}	data input set-up time		9	-	-	ns
t _{h(D)}	data input hold time		-	0	-	ns
t _{CSHOEH}	$\overline{\text{CS}}$ HIGH to $\overline{\text{OE}}$ HIGH time		3	0	-	ns
t _{CSHBLSH}	$\overline{\text{CS}}$ HIGH to $\overline{\text{BLS}}$ HIGH time		-	0	-	ns
t _{OEHAVN}	$\overline{\text{OE}}$ HIGH to address invalid time		10	-	-	ns
t _{BLSHAVN}	$\overline{\text{BLS}}$ HIGH to address invalid time		-	1 × HCLK	-	ns
Write cycle parameters						
t _{CSLDV}	$\overline{\text{CS}}$ LOW to data valid time		-	-	9	ns
t _{CSLWEL}	$\overline{\text{CS}}$ LOW to $\overline{\text{WE}}$ LOW time	[8][13]	-	(WAITWEN + 1) × HCLK	-	ns
t _{CSLBLSL}	$\overline{\text{CS}}$ LOW to $\overline{\text{BLS}}$ LOW time	[9][13]	-	WAITWEN × HCLK	-	ns
t _{WELDV}	$\overline{\text{WE}}$ LOW to data valid time	[10][13]	-	0 – (WAITWEN + 1) × HCLK	-	ns
t _{WELWEH}	$\overline{\text{WE}}$ LOW to $\overline{\text{WE}}$ HIGH time	[7][8] [13][14]	-	(WAITWR – WAITWEN + 1) × HCLK	-	ns
t _{BLSLBLSH}	$\overline{\text{BLS}}$ LOW to $\overline{\text{BLS}}$ HIGH time	[11][13] [14]	-	(WAITWR – WAITWEN + 3) × HCLK	-	ns
t _{WEHAVN}	$\overline{\text{WE}}$ HIGH to address invalid time		-	1 × HCLK	-	ns
t _{WEHDNV}	$\overline{\text{WE}}$ HIGH to data invalid time		-	1 × HCLK	-	ns
t _{BLSHAVN}	$\overline{\text{BLS}}$ HIGH to address invalid time		-	1 × HCLK	-	ns
t _{BLSHDNV}	$\overline{\text{BLS}}$ HIGH to data invalid time		-	1 × HCLK	-	ns

- [1] Refer to the *LPC315x user manual* for the programming of WAITOEN and HCLK.
- [2] Only when WAITRD is ≥ to WAITOEN, otherwise $\overline{\text{OE}}$, $\overline{\text{CS}}$, $\overline{\text{BLS}}$ and Address will change state about the same time.
- [3] WAITRD must be ≥ to WAITOEN for there to be any delay between $\overline{\text{CS}}$ active and $\overline{\text{OE}}$ active. The maximum delay is limited to (WAITRD × HCLK).

- [4] One HCLK cycle delay added when SYSCREG_MPMC_WAITREAD_DELAYx register bit 5 = 1.
- [5] WAITRD must \geq WAITOEN for there to be any delay between $\overline{\text{CS}}$ active and $\overline{\text{BLS}}$ active. The maximum delay is limited to (WAITRD * HCLK).
- [6] There is one less HCLK cycle when SYSCREG_MPMC_WAITREAD_DELAYx bit 5 = 1.
- [7] The MPMC will ensure a minimum of one HCLK for this parameter.
- [8] This formula applies when WAITWR is \geq WAITWEN. One HCLK cycle minimum.
- [9] This formula applies when WAITWR is \geq WAITWEN.
- [10] This formula applies when WAITWR is \geq WAITWEN. Data valid minimum One HCLK cycle before $\overline{\text{WE}}$ goes active.
- [11] This formula applies when WAITWR is \geq WAITWEN. Three HCLK cycles minimum.
- [12] Refer to the *LPC315x user manual* for the programming of WAITRD and HCLK.
- [13] Refer to the *LPC315x user manual* for the programming of WAITWEN and HCLK.
- [14] Refer to the *LPC315x user manual* for the programming of WAITWR and HCLK.

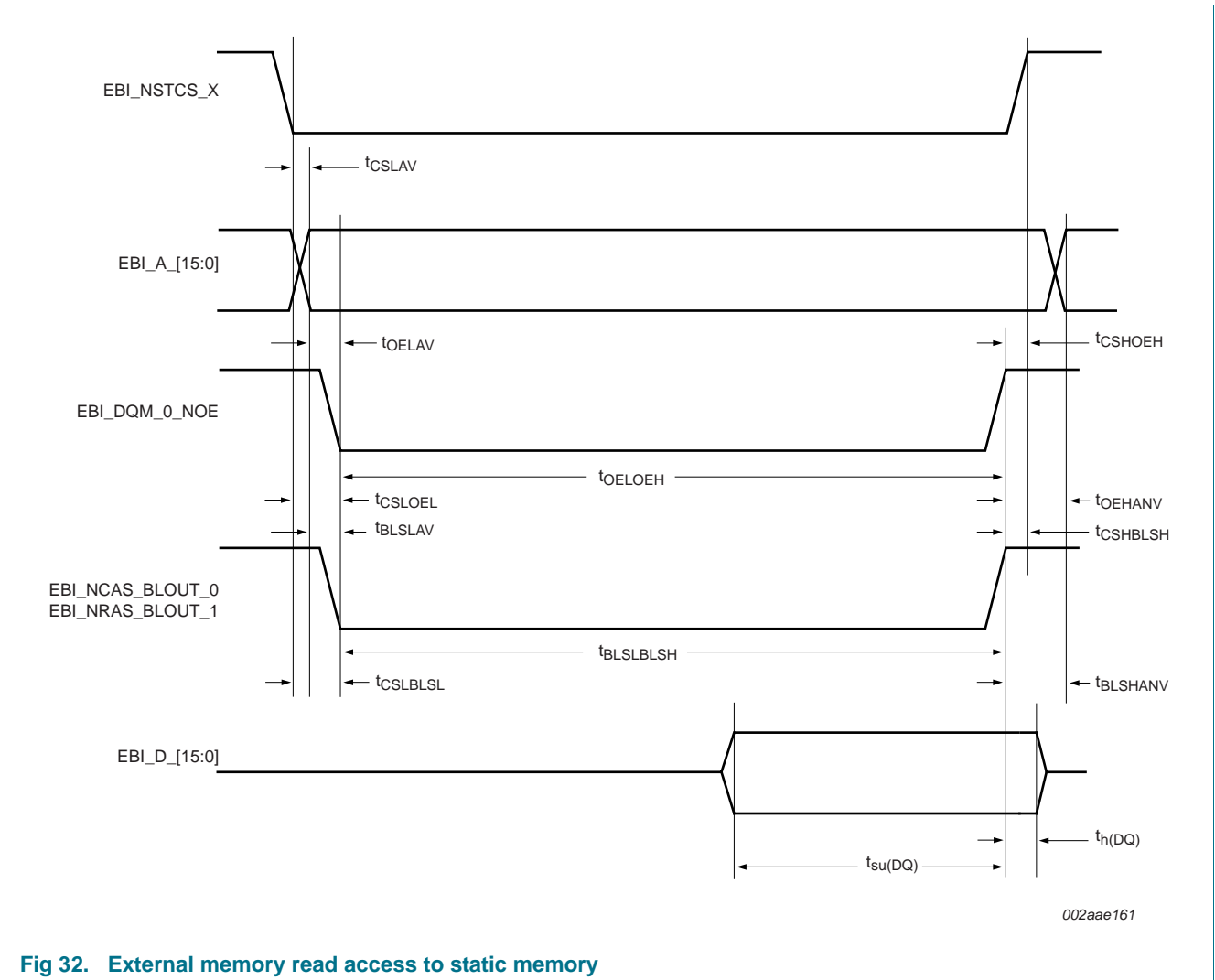

Fig 32. External memory read access to static memory

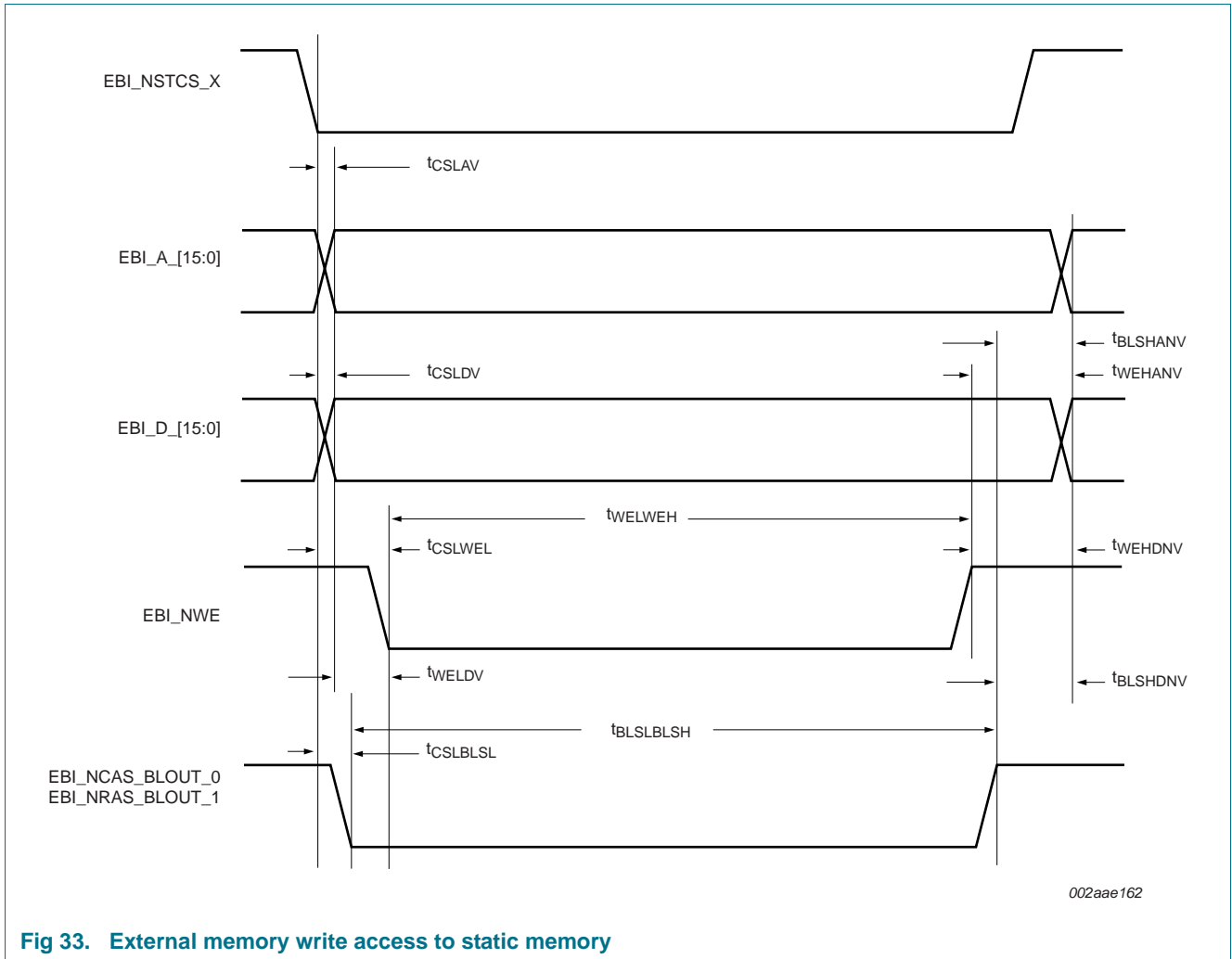

Fig 33. External memory write access to static memory

10.1.3 SDRAM controller

Table 34. Dynamic characteristics of SDR SDRAM memory interface

$T_{amb} = -40\text{ }^{\circ}\text{C}$ to $+85\text{ }^{\circ}\text{C}$, unless otherwise specified.^{[1][2][3]}

Symbol	Parameter	Conditions	Min	Typical	Max	Unit
f_{oper}	operating frequency		[4] -	80	90	MHz
t_{CLCX}	clock LOW time		-	5.55	-	ns
t_{CHCX}	clock HIGH time		-	5.55	-	ns
$t_{d(o)}$	output delay time	on pin EBI_CKE	[5] -	-	3.6	ns
		on pins EBI_NRAS_BLOUT, EBI_NCAS_BLOUT, EBI_NWE, EBI_NDYCS	-	-	3.6	ns
		on pins EBI_DQM_1, EBI_DQM_0_NOE	-	-	5	ns

Table 34. Dynamic characteristics of SDR SDRAM memory interface ...continued $T_{amb} = -40\text{ }^{\circ}\text{C}$ to $+85\text{ }^{\circ}\text{C}$, unless otherwise specified, [1][2][3]

Symbol	Parameter	Conditions	Min	Typical	Max	Unit
$t_{h(o)}$	output hold time	on pin EBI_CKE	[5] 0.13	-	3.6	ns
		on pins EBI_NRAS_BLOUT, EBI_NCAS_BLOUT, EBI_NWE, EBI_NDYCS	-0.1	-	3.6	ns
		on pins EBI_DQM_1, EBI_DQM_0_NOE	1.7	-	5	ns
$t_{d(AV)}$	address valid delay time		[5] -	-	5	ns
$t_{h(A)}$	address hold time		[5] -0.1	-	5	ns
$t_{d(QV)}$	data output valid delay time		[5] -	-	9	ns
$t_{h(Q)}$	data output hold time		[5] 4	-	10	ns
t_{QZ}	data output high-impedance time		-	-	$<T_{CLCL}$	ns

[1] Parameters are valid over operating temperature range unless otherwise specified.

[2] All values valid for pads set to high slew rate. $VDDE_{IOA} = VDDE_{IOB} = 1.8 \pm 0.15\text{ V}$. $VDDI = 1.2 \pm 0.1\text{ V}$.

[3] Refer to the LPC3152/3154 user manual for the programming of MPMCDynamicReadConfig and SYSCREG_MPMP_DELAYMODES registers.

[4] $f_{oper} = 1 / T_{CLCL}$

[5] $t_{d(o)}$, $t_{h(o)}$, $t_{d(AV)}$, $t_{h(A)}$, $t_{d(QV)}$, $t_{h(Q)}$ times are dependent on MPMCDynamicReadConfig register value and SYSCREG_MPMP_DELAYMODES register bits 11:6.

[6] $t_{su(D)}$, $t_{h(D)}$ times are dependent on SYSCREG_MPMP_DELAYMODES register bits 5:0.

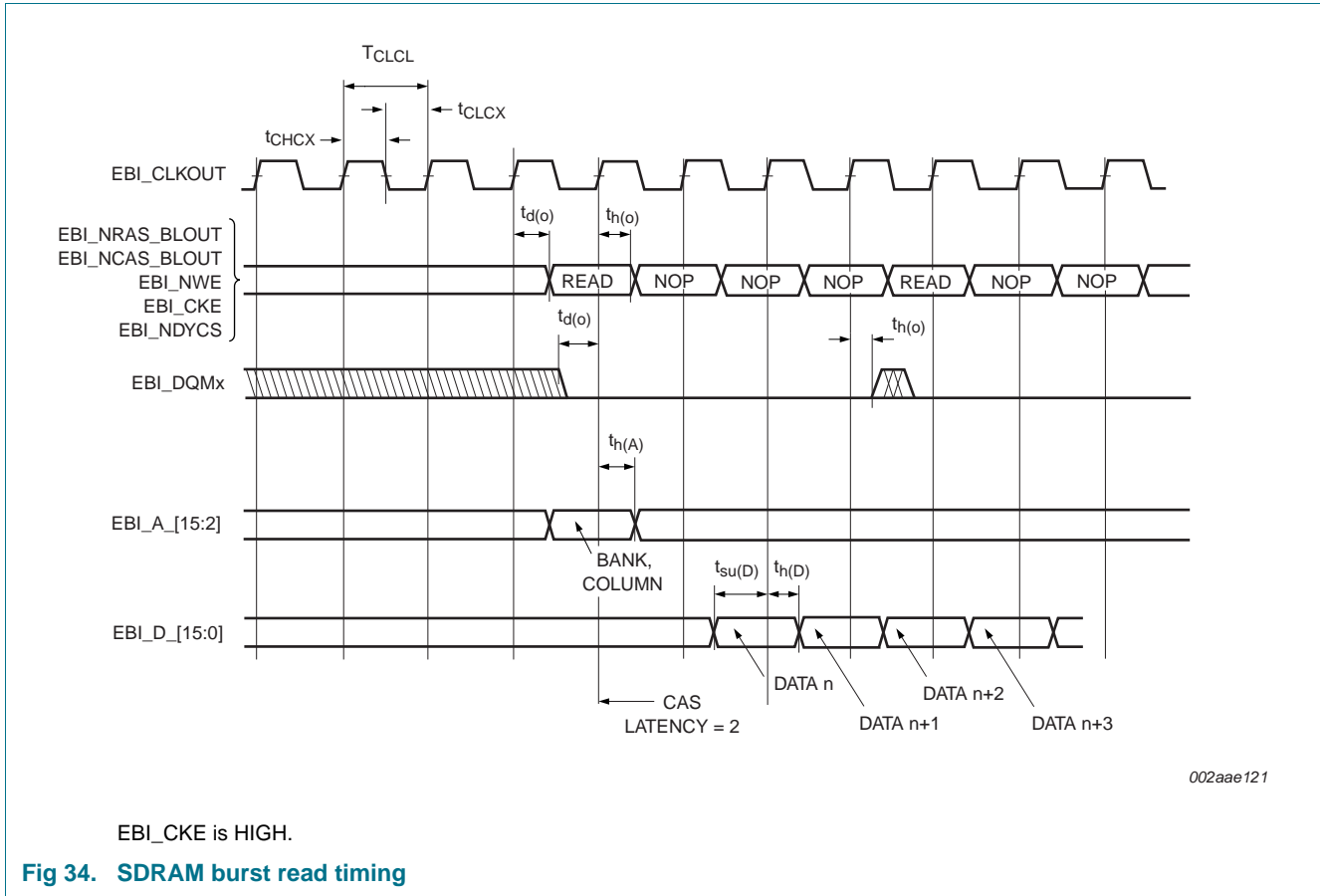

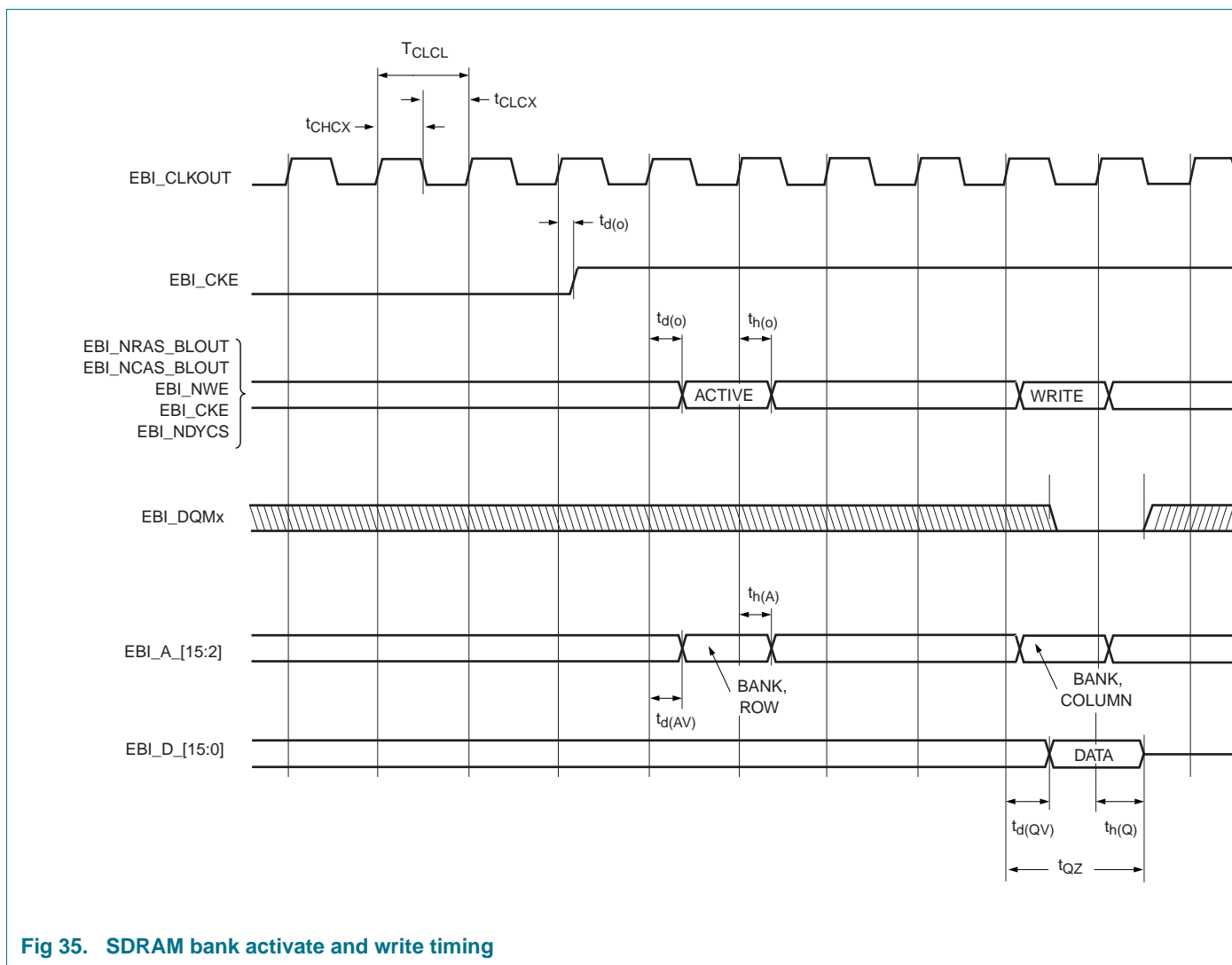

Fig 35. SDRAM bank activate and write timing

10.1.4 NAND flash memory controller

Table 35. Dynamic characteristics of the NAND Flash memory controller
T_{amb} = -40 °C to +85 °C, unless otherwise specified.

Symbol	Parameter	Typical	Unit
t _{REH}	\overline{RE} HIGH hold time	[1][2][3] T _{HCLK} × (T _{REH})	ns
t _{RP}	\overline{RE} pulse width	[1][2][3] T _{HCLK} × (T _{RP})	ns
t _{WH}	\overline{WE} HIGH hold time	[1][2][3] T _{HCLK} × (T _{WH})	ns
t _{WP}	\overline{WE} pulse width	[1][2][3] T _{HCLK} × (T _{WP})	ns
t _{CLS}	CLE set-up time	[1][2][3] T _{HCLK} × (T _{CLS})	ns
t _{CLH}	CLE hold time	[1][2][3] T _{HCLK} × (T _{CLH})	ns
t _{ALS}	ALE set-up time	[1][2][3] T _{HCLK} × (T _{ALS})	ns
t _{ALH}	ALE hold time	[1][2][3] T _{HCLK} × (T _{ALH})	ns
t _{CS}	\overline{CE} set-up time	[1][2][3] T _{HCLK} × (T _{CS})	ns
t _{CH}	\overline{CE} hold time	[1][2][3] T _{HCLK} × (T _{CH})	ns

- [1] T_{HCLK} = 1 / NANDFLASH_NAND_CLK, see LPC315x user manual.
- [2] See registers NandTiming1 and NandTiming2 in the LPC315x user manual.
- [3] Each timing parameter can be set from 7 nand_clk clock cycles to 1 nand_clk clock cycle. (A programmed zero value is treated as a one).

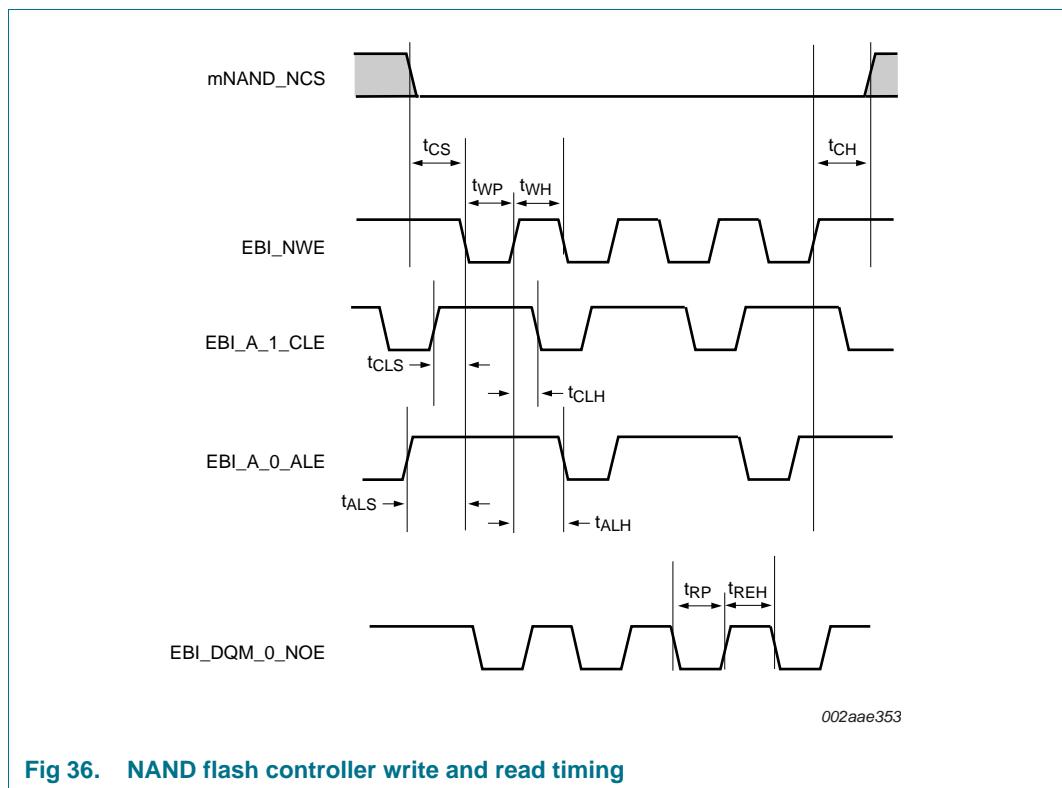

Fig 36. NAND flash controller write and read timing

10.1.5 Crystal oscillator

Table 36: Dynamic characteristics: crystal oscillator

Symbol	Parameter	Conditions	Min	Typ	Max	Unit
f_{osc}	oscillator frequency		10	12	25	MHz
δ_{clk}	clock duty cycle		45	50	55	%
C_{xtal}	crystal capacitance	input; on pin FFAST_IN	-	-	2	pF
		output; on pin FFAST_OUT	-	-	0.74	pF
$t_{startup}$	start-up time		-	500	-	μ s
P_{drive}	drive power		100	-	500	μ W

10.1.6 SPI

Table 37. Dynamic characteristics of SPI pins

$T_{amb} = -40\text{ }^{\circ}\text{C}$ to $+85\text{ }^{\circ}\text{C}$ for industrial applications

Symbol	Parameter	Min	Typ	Max	Unit
SPI master					
T_{SPICYC}	SPI cycle time	22.2	-	-	ns
$t_{SPICLKH}$	SPICLK HIGH time	11.09	-	11.14	ns
$t_{SPICLKL}$	SPICLK LOW time	11.09	-	11.14	ns
t_{SPIQV}	SPI data output valid time	-	-	14	ns
t_{SPIOH}	SPI output data hold time	9.9	-	-	ns
SPI slave					
t_{SPIOH}	SPI output data hold time	9.9	-	-	ns

Remark: Note that the signal names SCK, MISO, and MOSI correspond to signals on pins SPI_SCK, SPI_MOSI, and SPI_MISO in the following SPI timing diagrams.

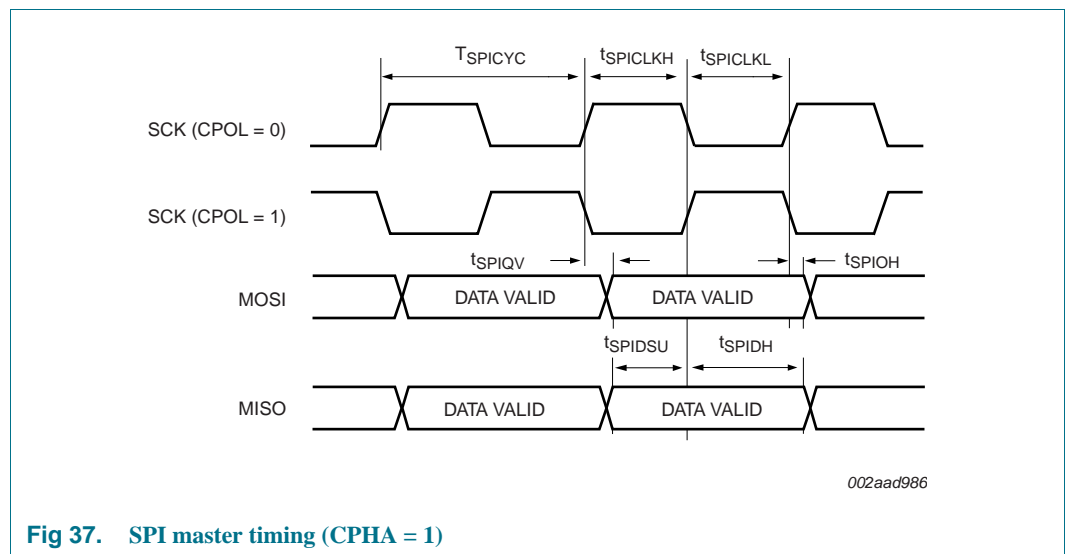

Fig 37. SPI master timing (CPHA = 1)

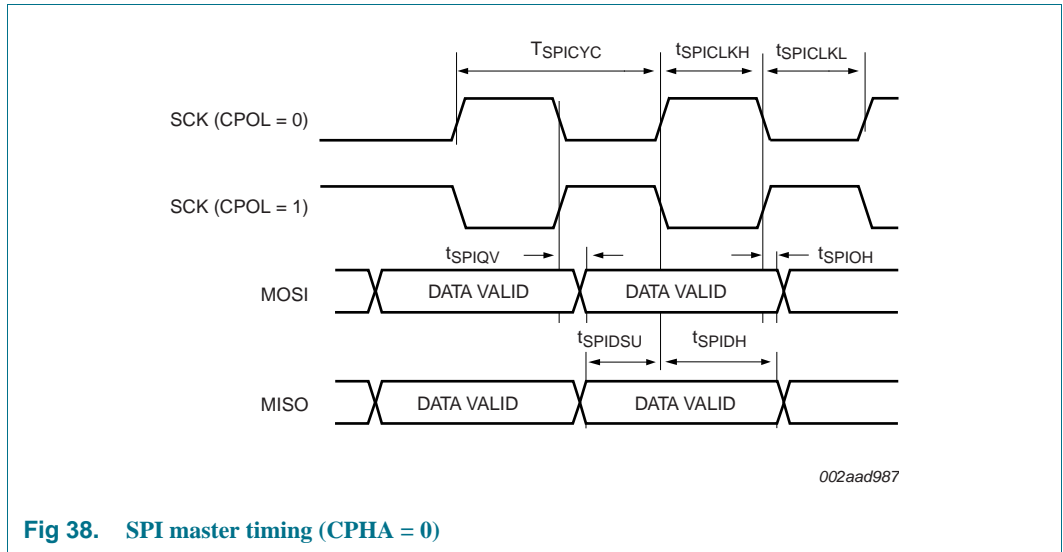

Fig 38. SPI master timing (CPHA = 0)

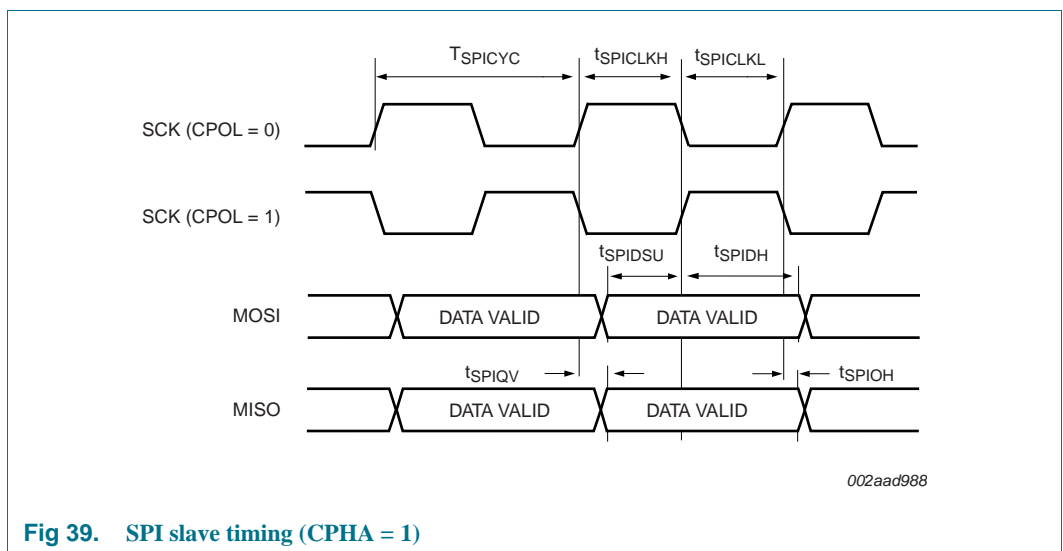

Fig 39. SPI slave timing (CPHA = 1)

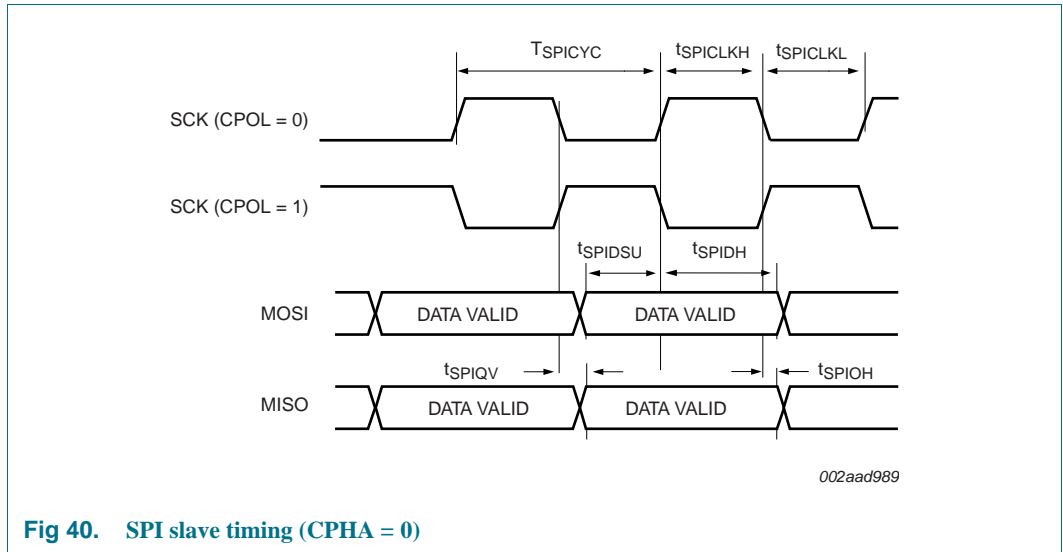

Fig 40. SPI slave timing (CPHA = 0)

10.1.6.1 Texas Instruments synchronous serial mode (SSP mode)

Table 38. Dynamic characteristic: SPI interface (SSP mode)

T_{amb} = -40 °C to +85 °C; V_{DD(I/O)} (SUP3) over specified ranges.^[1]

Symbol	Parameter	Conditions	Min	Typ ^[2]	Max	Unit
t _{su} (SPI_MISO)	SPI_MISO set-up time	T _{amb} = 25 °C; measured in SPI Master mode; see Figure 41	-	11	-	ns

[1] Parameters are valid over operating temperature range unless otherwise specified.

[2] Typical ratings are not guaranteed. The values listed are at room temperature (25 °C), nominal supply voltages.

Remark: Note that the signal names SCK, MISO, and MOSI correspond to signals on pins SPI_SCK, SPI_MOSI, and SPI_MISO in the following SPI timing diagram.

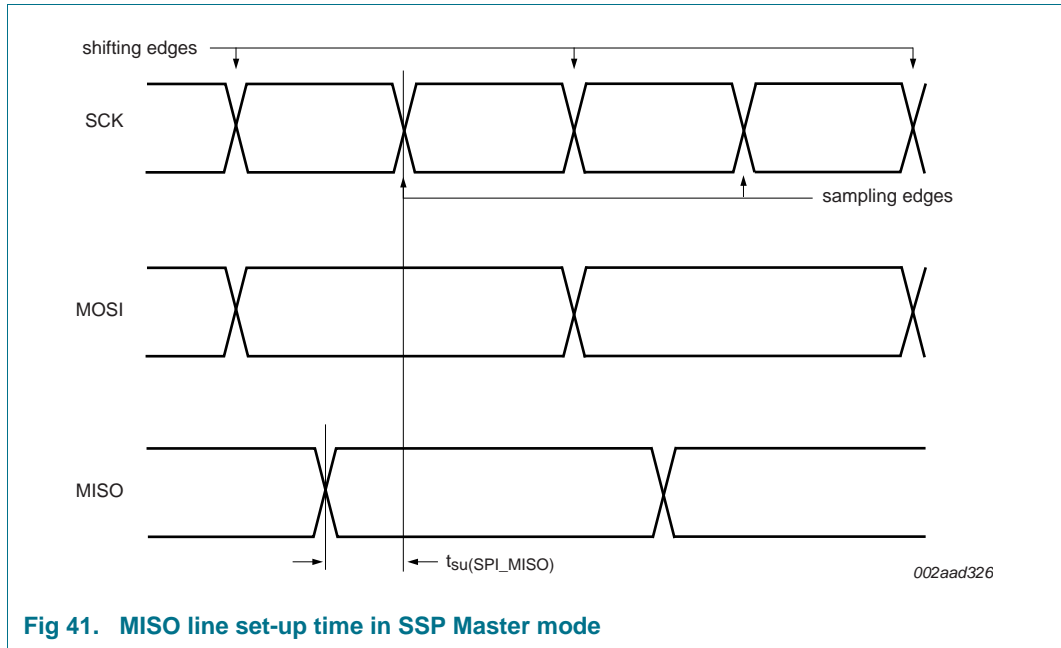

Fig 41. MISO line set-up time in SSP Master mode

10.1.7 10-bit ADC

Table 39: Dynamic characteristics: 10-bit ADC

Symbol	Parameter	Conditions	Min	Typ	Max	Unit
f _s	sampling frequency	10 bit resolution	400	-	-	kSamples/s
		2 bit resolution	-	-	1500	kSamples/s
t _{conv}	conversion time	10 bit resolution	-	-	11	clock cycles
		2 bit resolution	3	-	-	clock cycles

10.2 Analog die/audio system

Table 40. Dynamic characteristics of Class AB amplifier

T_{amb} = -40 °C to +85 °C unless otherwise specified. V_{DD(ADC)} = 3.3 V on pin ADC_VDDA33.

Symbol	Parameter	Conditions	Min	Typ	Max	Unit	
V _O	output voltage	HP unloaded	-	800	-	mV(RMS)	
P _O	output power	per channel; RL=16 Ω			23.5	mW	
(THD+N)/S	Total harmonic distortion plus noise-to-signal ratio	at 0 dBFS; f _{in} = 1 kHz; RL=16 Ω	[1]	-	-60	-	dB
		at -60 dBFS; f _{in} = 1 kHz; RL=16 Ω	-	-40	-30	dBA	
S/N	Signal-to-noise ratio		[1]	100	-	dBA	
PSRR	power supply rejection ratio		-	6	-	dB	
α _{ct(ch)}	channel crosstalk	RL=16 Ω; between left channel and right channel	-	-55	-	dB	

[1] Measured with 20 kHz block filter.

Table 41: Dynamic characteristic for analog in*T_{amb} = -40 °C to +85 °C unless otherwise specified.*

Symbol	Parameter	Conditions	Min	Typ	Max	Unit
B	Bandwidth		-	-	20	kHz
Tuner						
(THD+N)/S	Total harmonic distortion plus noise-to-signal ratio	at 0 dBFS; f _{in} = 1 kHz; Line input level = 1 V; PGA setting +12 dB; external resistor of 36 kΩ	-	-83	-80	dB
		at 0 dBFS; f _{in} = 1 kHz; Line input level = 1 V, PGA setting 0 dB	-	-70	-	dB
		at -60 dBFS; A-weighted; f _{in} = 1 kHz; Line input level = 1mV, PGA setting 0dB	-	-34	-30	dBA
S/N	Signal-to-noise ratio	A-weighted; line input = 1 V, PGA setting 0 dB	90	94	-	dBA
Z _i	input impedance	line in (tuner mode)	-	12	-	kΩ
Microphone						
THD	total harmonic distortion	V _i = 20 mV; f _{in} = 1 kHz	-	-70	-60	dB
		V _i = 0.3 mV; f _{in} = 1 kHz	-	-90	-80	dB
Z _i	input impedance	microphone mode	-	5	-	kΩ

11. Application information

Table 42. LCD panel connections

TFBGA pin #	Pin name	Reset function (default)	LCD mode			Control function	
			Parallel	LCD panel data mapping		6800	8000
			16 bit	8 bit	4 bit		
R8	mLCD_CSB/EBI_NSTCS_0	LCD_CSB	-	-	-	LCD_CSB	LCD_CSB
P7	mLCD_E_RD/EBI_CKE	LCD_E_RD	-	-	-	LCD_E	LCD_E
R7	mLCD_RS/EBI_NDYCS	LCD_RS	-	-	-	LCD_RS	LCD_RS
T8	mLCD_RW_WR/EBI_DQM_1	LCD_RW_WR	-	-	-	LCD_RW	LCD_RW
T7	mLCD_DB_0/EBI_CLKOUT	LCD_DB_0	LCD_DB_0	-	-	-	-
P8	mLCD_DB_1/EBI_NSTCS_1	LCD_DB_1	LCD_DB_1	-	-	-	-
T6	mLCD_DB_2/EBI_A_2	LCD_DB_2	LCD_DB_2	-	-	-	-
R6	mLCD_DB_3/EBI_A_3	LCD_DB_3	LCD_DB_3	-	-	-	-
U6	mLCD_DB_4/EBI_A_4	LCD_DB_4	LCD_DB_4	-	-	-	-
P6	mLCD_DB_5/EBI_A_5	LCD_DB_5	LCD_DB_5	-	-	-	-
R5	mLCD_DB_6/EBI_A_6	LCD_DB_6	LCD_DB_6	-	-	-	-
T5	mLCD_DB_7/EBI_A_7	LCD_DB_7	LCD_DB_7	-	-	-	-
U5	mLCD_DB_8/EBI_A_8	LCD_DB_8	LCD_DB_8	LCD_DB_0	-	-	-
P5	mLCD_DB_9/EBI_A_9	LCD_DB_9	LCD_DB_9	LCD_DB_1	-	-	-
P4	mLCD_DB_10/EBI_A_10	LCD_DB_10	LCD_DB_10	LCD_DB_2	-	-	-
U4	mLCD_DB_11/EBI_A_11	LCD_DB_11	LCD_DB_11	LCD_DB_3	-	-	-
T4	mLCD_DB_12/EBI_A_12	LCD_DB_12	LCD_DB_12	LCD_DB_4	LCD_DB_0	-	-
U3	mLCD_DB_13/EBI_A_13	LCD_DB_13	LCD_DB_13	LCD_DB_5	LCD_DB_1	-	-
U2	mLCD_DB_14/EBI_A_14	LCD_DB_14	LCD_DB_14	LCD_DB_6	LCD_DB_2	-	-
R4	mLCD_DB_15/EBI_A_15	LCD_DB_15	LCD_DB_15	LCD_DB_7	LCD_DB_3	-	-

All information provided in this document is subject to legal disclaimers.

© NXP B.V. 2012. All rights reserved.

12. Marking

Table 43. LPC3152/3154 Marking

Line	Marking	Description
A	LPC3152/3154	BASIC_TYPE

13. Package outline

TFBGA208: plastic thin fine-pitch ball grid array package; 208 balls; body 12 x 12 x 0.7 mm

SOT930-1

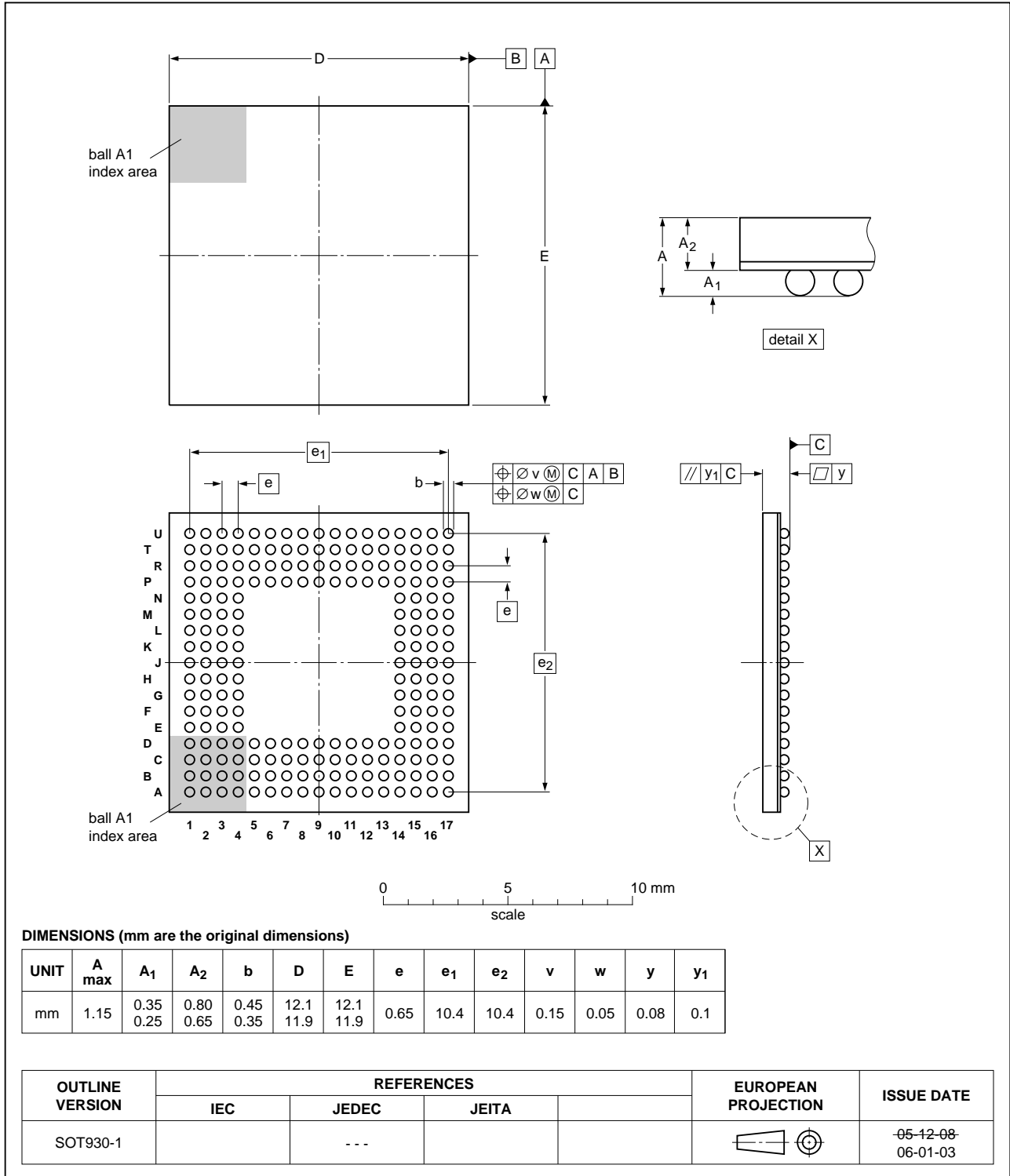

Fig 42. LPC3152/3154 TFBGA208 package outline

14. Abbreviations

Table 44: Abbreviations

Acronym	Description
ADC	Analog-to-Digital Converter
ADC10B	10 Bit Analogue to Digital Converter
AES	Advanced Encryption Standard
AVC	Analog Volume Control
BIU	Bus Interface Unit
CBC	Cipher Block Chaining
CD	Compact Disk
CGU	Clock Generation Unit
DFU	Device Firmware Upgrade
DMA	Direct Memory Access Controller
DRM	Digital Rights Management
ECC	Error Correction Code
FIR	Finite Input Response
HP	Headphones
IOCONFIG	Input Output Configuration
ROM	Read Only Memory
IrDA	Infrared Data Association
JTAG	Joint Test Action Group
ISRAM	Internal Static RAM Memory
JTAG	Joint Test Action Group
LCD	Liquid Crystal Display
LDO	Low Drop voltage Output regulator
LNA	Low-Noise Amplifier
MMU	Memory Management Unit
NTC	Negative Temperature Coefficient
OTP	One-Time Programmable Memory
PCM	Pulse Code Modulation
PGA	Programmable Gain Amplifier
PHY	Physical Layer
PLL	Phase Locked Loop
PSU	Power Supply Unit
PWM	Pulse Width Modulation
RNG	Random Number Generator
SDC	
SHA1	Secure Hash Algorithm 1
SIR	Serial IrDA
SPI	Serial Peripheral Interface
SSI	Serial Synchronous Interface
SysCReg	System Control Registers

Table 44: Abbreviations ...continued

Acronym	Description
Timer	Timer module
UART	Universal Asynchronous Receiver Transmitter
USB 2.0 HS OTG	Universal Serial Bus 2.0 High-Speed On-The-Go

15. Revision history

Table 45: Revision history

Document ID	Release date	Data sheet status	Change notice	Supersedes
LPC3152_54	20120531	Product data sheet	-	-

16. Legal information

16.1 Data sheet status

Document status ^{[1][2]}	Product status ^[3]	Definition
Objective [short] data sheet	Development	This document contains data from the objective specification for product development.
Preliminary [short] data sheet	Qualification	This document contains data from the preliminary specification.
Product [short] data sheet	Production	This document contains the product specification.

[1] Please consult the most recently issued document before initiating or completing a design.

[2] The term 'short data sheet' is explained in section "Definitions".

[3] The product status of device(s) described in this document may have changed since this document was published and may differ in case of multiple devices. The latest product status information is available on the Internet at URL <http://www.nxp.com>.

16.2 Definitions

Draft — The document is a draft version only. The content is still under internal review and subject to formal approval, which may result in modifications or additions. NXP Semiconductors does not give any representations or warranties as to the accuracy or completeness of information included herein and shall have no liability for the consequences of use of such information.

Short data sheet — A short data sheet is an extract from a full data sheet with the same product type number(s) and title. A short data sheet is intended for quick reference only and should not be relied upon to contain detailed and full information. For detailed and full information see the relevant full data sheet, which is available on request via the local NXP Semiconductors sales office. In case of any inconsistency or conflict with the short data sheet, the full data sheet shall prevail.

Product specification — The information and data provided in a Product data sheet shall define the specification of the product as agreed between NXP Semiconductors and its customer, unless NXP Semiconductors and customer have explicitly agreed otherwise in writing. In no event however, shall an agreement be valid in which the NXP Semiconductors product is deemed to offer functions and qualities beyond those described in the Product data sheet.

16.3 Disclaimers

Limited warranty and liability — Information in this document is believed to be accurate and reliable. However, NXP Semiconductors does not give any representations or warranties, expressed or implied, as to the accuracy or completeness of such information and shall have no liability for the consequences of use of such information. NXP Semiconductors takes no responsibility for the content in this document if provided by an information source outside of NXP Semiconductors.

In no event shall NXP Semiconductors be liable for any indirect, incidental, punitive, special or consequential damages (including - without limitation - lost profits, lost savings, business interruption, costs related to the removal or replacement of any products or rework charges) whether or not such damages are based on tort (including negligence), warranty, breach of contract or any other legal theory.

Notwithstanding any damages that customer might incur for any reason whatsoever, NXP Semiconductors' aggregate and cumulative liability towards customer for the products described herein shall be limited in accordance with the *Terms and conditions of commercial sale* of NXP Semiconductors.

Right to make changes — NXP Semiconductors reserves the right to make changes to information published in this document, including without limitation specifications and product descriptions, at any time and without notice. This document supersedes and replaces all information supplied prior to the publication hereof.

Suitability for use — NXP Semiconductors products are not designed, authorized or warranted to be suitable for use in life support, life-critical or safety-critical systems or equipment, nor in applications where failure or malfunction of an NXP Semiconductors product can reasonably be expected to result in personal injury, death or severe property or environmental damage. NXP Semiconductors and its suppliers accept no liability for inclusion and/or use of NXP Semiconductors products in such equipment or applications and therefore such inclusion and/or use is at the customer's own risk.

Applications — Applications that are described herein for any of these products are for illustrative purposes only. NXP Semiconductors makes no representation or warranty that such applications will be suitable for the specified use without further testing or modification.

Customers are responsible for the design and operation of their applications and products using NXP Semiconductors products, and NXP Semiconductors accepts no liability for any assistance with applications or customer product design. It is customer's sole responsibility to determine whether the NXP Semiconductors product is suitable and fit for the customer's applications and products planned, as well as for the planned application and use of customer's third party customer(s). Customers should provide appropriate design and operating safeguards to minimize the risks associated with their applications and products.

NXP Semiconductors does not accept any liability related to any default, damage, costs or problem which is based on any weakness or default in the customer's applications or products, or the application or use by customer's third party customer(s). Customer is responsible for doing all necessary testing for the customer's applications and products using NXP Semiconductors products in order to avoid a default of the applications and the products or of the application or use by customer's third party customer(s). NXP does not accept any liability in this respect.

Limiting values — Stress above one or more limiting values (as defined in the Absolute Maximum Ratings System of IEC 60134) will cause permanent damage to the device. Limiting values are stress ratings only and (proper) operation of the device at these or any other conditions above those given in the Recommended operating conditions section (if present) or the Characteristics sections of this document is not warranted. Constant or repeated exposure to limiting values will permanently and irreversibly affect the quality and reliability of the device.

Terms and conditions of commercial sale — NXP Semiconductors products are sold subject to the general terms and conditions of commercial sale, as published at <http://www.nxp.com/profile/terms>, unless otherwise agreed in a valid written individual agreement. In case an individual agreement is concluded only the terms and conditions of the respective agreement shall apply. NXP Semiconductors hereby expressly objects to applying the customer's general terms and conditions with regard to the purchase of NXP Semiconductors products by customer.

No offer to sell or license — Nothing in this document may be interpreted or construed as an offer to sell products that is open for acceptance or the grant, conveyance or implication of any license under any copyrights, patents or other industrial or intellectual property rights.

Export control — This document as well as the item(s) described herein may be subject to export control regulations. Export might require a prior authorization from competent authorities.

Non-automotive qualified products — Unless this data sheet expressly states that this specific NXP Semiconductors product is automotive qualified, the product is not suitable for automotive use. It is neither qualified nor tested in accordance with automotive testing or application requirements. NXP Semiconductors accepts no liability for inclusion and/or use of non-automotive qualified products in automotive equipment or applications.

In the event that customer uses the product for design-in and use in automotive applications to automotive specifications and standards, customer (a) shall use the product without NXP Semiconductors' warranty of the product for such automotive applications, use and specifications, and (b)

whenever customer uses the product for automotive applications beyond NXP Semiconductors' specifications such use shall be solely at customer's own risk, and (c) customer fully indemnifies NXP Semiconductors for any liability, damages or failed product claims resulting from customer design and use of the product for automotive applications beyond NXP Semiconductors' standard warranty and NXP Semiconductors' product specifications.

16.4 Trademarks

Notice: All referenced brands, product names, service names and trademarks are the property of their respective owners.

I²C-bus — logo is a trademark of NXP B.V.

17. Contact information

For more information, please visit: <http://www.nxp.com>

For sales office addresses, please send an email to: salesaddresses@nxp.com

18. Contents

1	General description	1	6.31	System control registers	38
2	Features and benefits	1	6.32	Audio Subsystem (ADSS)	38
2.1	Key features	1	6.32.1	I ² S0/1 digital audio input/output	39
3	Ordering information	2	7	Functional description of the analog die blocks	40
3.1	Ordering options	3	7.1	Analog die	40
4	Block diagram	4	7.2	Audio codec	41
5	Pinning information	5	7.2.1	Stereo Digital-to-Analog Converter (SDAC)	41
5.1	Pinning	5	7.2.2	Class AB headphone amplifier	42
6	Functional description	15	7.2.3	Stereo Analog-to-Digital Converter (SADC) for Audio	42
6.1	ARM926EJ-S	15	7.3	Li-ion charger	43
6.2	Memory map	16	7.4	USB charge pump (host mode)	44
6.2.1	Analog die memory organization	16	7.5	Power Supply Unit (PSU)	44
6.3	JTAG	17	7.6	Real-Time Clock (RTC)	46
6.4	NAND flash controller	17	8	Limiting values	47
6.5	Multi-Port Memory Controller (MPMC)	19	9	Static characteristics	48
6.6	External Bus Interface (EBI)	20	9.1	Digital die	48
6.7	Internal ROM Memory	20	9.2	Analog die	53
6.8	Internal RAM memory	21	9.2.1	PSU	53
6.9	Memory Card Interface (MCI)	22	9.2.1.1	PSU_VOUT1 efficiency	58
6.10	Universal Serial Bus 2.0 High Speed On-The-Go (OTG)	22	9.2.1.2	PSU_VOUT2 efficiency	59
6.11	DMA controller	23	9.2.1.3	UOS_VBUS PSU efficiency	59
6.12	Interrupt controller	24	9.2.2	Li-ion charger	61
6.13	Multi-layer AHB	24	9.3	Power consumption	61
6.14	APB bridge	26	9.3.1	STOP mode power consumption	61
6.15	Clock Generation Unit (CGU)	26	9.3.1.1	RTC_BACKUP pin power consumption	62
6.16	Watchdog Timer (WDT)	28	9.3.2	Standby mode power consumption	63
6.17	Input/Output configuration module (IOCONFIG)	29	9.3.3	Typical and maximum power consumption based on scenario	63
6.18	10-bit Analog-to-Digital Converter (ADC10B)	29	9.3.3.1	Summary of power consumption scenarios	63
6.19	Event router	30	9.3.3.2	System standby mode	64
6.20	Random Number Generator (RNG)	31	9.3.3.3	Dhrystone tests in IRAM with MMU, no dynamic clocking	65
6.21	AES decryption (LPC3154 only)	31	9.3.3.4	Dhrystone tests in IRAM with MMU off, no dynamic clocking	65
6.22	Secure One-Time Programmable (OTP) memory	31	9.3.3.5	Linux idle at console prompt	66
6.23	Serial Peripheral Interface (SPI)	31	9.3.3.6	Linux running full load	67
6.24	Universal Asynchronous Receiver Transmitter (UART)	32	9.3.3.7	Built-in audio tests	69
6.25	Pulse Code Modulation (PCM) interface	32	10	Dynamic characteristics	70
6.26	LCD interface	33	10.1	Digital die	70
6.27	I ² C-bus master/slave interface	33	10.1.1	LCD controller	70
6.28	LCD/NAND flash/SDRAM multiplexing	34	10.1.1.1	Intel 8080 mode	70
6.28.1	Pin connections	34	10.1.1.2	Motorola 6800 mode	71
6.28.2	Multiplexing between LCD and MPMC	36	10.1.1.3	Serial mode	72
6.28.3	Supply domains	37	10.1.2	SRAM controller	73
6.29	Timer module	38	10.1.3	SDRAM controller	75
6.30	Pulse Width Modulation (PWM) module	38			

continued >>

10.1.4	NAND flash memory controller	79
10.1.5	Crystal oscillator	80
10.1.6	SPI	80
10.1.6.1	Texas Instruments synchronous serial mode (SSP mode)	82
10.1.7	10-bit ADC	83
10.2	Analog die/audio system	83
11	Application information.	85
12	Marking.	86
13	Package outline	87
14	Abbreviations.	88
15	Revision history.	90
16	Legal information.	91
16.1	Data sheet status	91
16.2	Definitions	91
16.3	Disclaimers	91
16.4	Trademarks	92
17	Contact information.	92
18	Contents	93

Please be aware that important notices concerning this document and the product(s) described herein, have been included in section 'Legal information'.

© NXP B.V. 2012.

All rights reserved.

For more information, please visit: <http://www.nxp.com>

For sales office addresses, please send an email to: salesaddresses@nxp.com

Date of release: 31 May 2012

Document identifier: LPC3152_54

X-ON Electronics

Largest Supplier of Electrical and Electronic Components

Click to view similar products for [Development Boards & Kits - ARM category](#):

Click to view products by [NXP manufacturer](#):

Other Similar products are found below :

[SAFETI-HSK-RM48](#) [PICOHOBBITFL](#) [CC-ACC-MMK-2443](#) [TWR-MC-FRDMKE02Z](#) [EVALSPEAR320CPU](#) [EVB-SCMIMX6SX](#)
[MAX32600-KIT#](#) [TMDX570LS04HDK](#) [TXSD-SV70](#) [OM13080UL](#) [EVAL-ADUC7120QSPZ](#) [OM13082UL](#) [TXSD-SV71](#)
[YGRPEACHNORMAL](#) [OM13076UL](#) [PICODWARFFL](#) [YR8A77450HA02BG](#) [3580](#) [32F3348DISCOVERY](#) [ATTINY1607](#) [CURIOSITY](#)
[NANO](#) [PIC16F15376](#) [CURIOSITY NANO BOARD](#) [PIC18F47Q10](#) [CURIOSITY NANO](#) [VISIONSTK-6ULL V.2.0](#) [80-001428](#) [DEV-17717](#)
[EAK00360](#) [YR0K77210B000BE](#) [RTK7EKA2L1S00001BE](#) [MAX32651-EVKIT#](#) [SLN-VIZN-IOT](#) [LV18F V6 DEVELOPMENT SYSTEM](#)
[READY FOR AVR BOARD](#) [READY FOR PIC BOARD](#) [READY FOR PIC \(DIP28\)](#) [EVB-VF522R3](#) [AVRPLC16 V6 PLC SYSTEM](#)
[MIKROLAB FOR AVR XL](#) [MIKROLAB FOR PIC L](#) [MINI-AT BOARD - 5V](#) [MINI-M4 FOR STELLARIS](#) [MOD-09.Z](#) [BUGGY +](#)
[CLICKER 2 FOR PIC32MX + BLUETOOT](#) [1410](#) [LETS MAKE PROJECT PROGRAM. RELAY PIC](#) [LETS MAKE - VOICE](#)
[CONTROLLED LIGHTS](#) [LPC-H2294](#) [DSPIC-READY2 BOARD](#) [DSPIC-READY3 BOARD](#) [MIKROBOARD FOR ARM 64-PIN](#)
[MIKROLAB FOR AVR](#)