



UM10430

LPC18xx ARM Cortex-M3 microcontroller

Rev. 3.0 — 26 July 2017

User manual

Document information

Info	Content
Keywords	LPC18xx, LPC1850, LPC1830, LPC1820, LPC1810, LPC185x, LPC183x, LPC182x, LPC181x, LPC18Sxx, LPC18S50, LPC18S30, LPC18S20, LPC18S10, LPC18S5x, LPC18S3x, LPC18S2x, LPC18S1x, ARM Cortex-M3, SPIFI, SCT, USB, Ethernet, LPC1800, LPC1800 User manual
Abstract	LPC18xx user manual



Revision history

Rev	Date	Description
3.0	20170726	LPC18xx user manual
Modifications:		<ul style="list-style-type: none"> Updated Section 12.2.1.1 “Changing the BASE_M3_CLK after power-up, reset, or deep power-down mode”. Added list item 4. Updated Section 12.2.1.2 “Changing the BASE_M3_CLK after waking up from deep-sleep or power-down modes”. Added list item 3. Updated Table 114 “PLL0USB control register (PLL0USB_CTRL, address 0x4005_0020) bit description”. Added table note to AUTOBLOCK, bit 11. Updated Table 118 “PLL0AUDIO control register (PLL0AUDIO_CTRL, address 0x4005_0030) bit description”. Added table note to AUTOBLOCK, bit 11. Updated Table 123 “PLL1_CTRL register (PLL1_CTRL, address 0x4005_0044) bit description”. Added table note to AUTOBLOCK, bit 11.
2.9	20170118	LPC18xx user manual
Modifications:		<ul style="list-style-type: none"> Fixed formatting issues. Updated Table 19 “QSPI devices supported by the boot code and the SPIFI API”: Deleted Table: QSPI devices not supported by the boot code.
2.8	20151210	LPC18xx user manual
Modifications:		<ul style="list-style-type: none"> Fixed formatting issues. Added CREG1 register. See Table 90 “CREG1 register (CREG1, address 0x4004_3008) bit description”. Updated text in Section 12.2.1 “Configuring the BASE_M3_CLK for high operating frequencies”: To ramp up the clock frequency to an operating frequency above 110 MHz configure the core clock BASE_M4_CLK as described in Section 12.2.1.1. Updated description for USB0 (Event 9) and USB1(Event 10) peripheral in Table 75 “Event router inputs”; USB0: Wake-up request signal. Not active in power-down and deep power-down mode. Use for wake-up from sleep and deep-sleep mode; USB1: USB1 AHB_NEED_CLK signal. Not active in power-down and deep power-down mode. Use for wake up from sleep and deep-sleep mode. Updated Table 170 “LPC1850/30/20/10 Pin description (flashless parts)”: Fixed PD_3 to be "SCT Output 6"; was SCT Output 7.

Revision history ...continued

Rev	Date	Description
2.7	20151104	LPC18xx user manual
Modifications:		<ul style="list-style-type: none"> Added S parts to Table 1 “Ordering information”, Table 2 “Ordering options (flashless parts)”, Table 3 “Ordering information (parts with on-chip flash)”, and Table 4 “Ordering options (parts with on-chip flash)”. Added 16 kB EEPROM in Section 1.2 “Features”. Added the line to the remark in Section 10.4.10 “USB0 frame length adjust register” and Section 10.4.11 “USB1 frame length adjust register”: This register should be read before the initialization of USB0 and USB1. Fixed typographical error in Section 6.2 “Features”: Cipher-Block chaining. Added the paragraph: The Motor control PWM is not available on LPC1810FET100, LPC1820FET100, and LPC1830FET100 parts to Section 31.1 “How to read this chapter”. Added 0x10 to all the offsets for exception numbers 53 and above ending with 0x110 for the QEI vector. See Table 72 “Connection of interrupt sources to the NVIC”. Added device and hex coding information for S parts to Table 40 “LPC18xx part identification numbers”. Fixed CBC to read Cipher Block Chaining instead of Cipher Book Chaining in Section 8.2 “Features”. Updated Section 28.6 “Register description” text. Was REGMODEn = 1: Registers operate as match and reload registers. REGMODEn = 0: Registers operate as capture and capture control registers. 0 and 1 reversed to read, REGMODEn = 0: Registers operate as match and reload registers. REGMODEn = 1: Registers operate as capture and capture control registers. Updated Section 29.3 “Register description” text. Was REGMODEn = 1: Registers operate as match and reload registers. REGMODEn = 0: Registers operate as capture and capture control registers. 0 and 1 reversed to read, REGMODEn = 0: Registers operate as match and reload registers. REGMODEn = 1: Registers operate as capture and capture control registers. Fixed references to LPC18xx in List item 5 on page 97 and Section 7.3.4 “CMAC”: For LPC18xx the chosen CMAC parameters are: encryption key K = User Key (AES key1, same as used for decryption) and tag length l = 64. Updated Table 18 “Boot image header description”: Reserved bits: 15:8 instead of 15:14. Updated Table 69 “Boot image header description”: AES_CONTROL bits: 15:8. added a remark before the table. In Table 103 “Power-down modes register (PD0_SLEEPO_MODE - address 0x4004 201C) bit description” “Power-down modes register (PD0_SLEEPO_MODE - address 0x4004 201C) bit description”, the value of Deep power down mode is changed to 0x0033 FF7F. In Table 14 “OTP function allocation”, updated otp_ProgUSBID: otp_ProgUSBID will program prod_id and vend_id in word 1 of bank 3: 3; word 1. Re-named Part ID register to CHIP ID register: Table 88 “Register overview: Configuration registers (base address 0x4004 3000)” and Table 97 “Chip ID register (CHIPID, address 0x4004 3200) bit description”. Added CHIP ID for Flash devices Rev A: CHIP ID is 0x7906 002B to Table 97. Added SBUSCFG register. See Table 384 “System bus interface configuration register (SBUSCFG - address 0x4000 6090) bit description”. Added a remark in Section 23.6.10 “Burst Size register (BURSTSIZE)”. Updated Figure 21 “IAP parameter passing”. Changed the IAP command array size to 5: See Section 5.8 “IAP commands”. Define data structure or pointers to pass the IAP command table and result table to the IAP function: unsigned long command[5]; unsigned long result[5];

Revision history ...continued

Rev	Date	Description
Modifications:	<ul style="list-style-type: none"> Updated Table 48 “IAP Copy RAM to Flash command”. Added a bullet to Section 5.2 “Basic configuration”. If the application uses the IAP interface, it must reserve the SRAM space used by IAP as outlined in Section 5.4.5.8 “RAM used by IAP command handler”. Updated Section 5.4.5.8 “RAM used by IAP command handler”. Added text: 16 B of RAM from 0x10089FF0 to 0x10089FFF. Applications making use of IAP calls must reserve this RAM block. Updated Section 5.4.5.7 “RAM used by ISP”; removed command handler from the title and updated text. Updated Figure 27 “Boot flow for encrypted images (flashless parts)”. Updated Figure 32 “AES endianness”. 	
2.6	20150210	LPC18xx user manual
Modifications:	<ul style="list-style-type: none"> Table 700 “SCT configuration example” corrected. Number of EMC_CS and EMC_DYCS pins corrected for the LQFP208 pin package in Table 343 “EMC pinout for different packages”. Section 38.7.5.1 “USART clock in synchronous mode” added. Bit 12 changed to 1 for EMC address mapping 256 Mb, 512 Mb, 1 Gb. See Table 367 “Address mapping”. Bit description of bits TSEG1 and TSEG2 corrected in Table 976 “CAN bit timing register (BT, address 0x400E 200C (C_CAN0) and 0x400A 400C (C_CAN1)) bit description” and Figure 172 “Bit timing” updated for clarification. Parts MX1635E, W25Q16DV, W25Q32FV added to Table 19 “QSPI devices supported by the boot code and the SPIFI API”. Use of IAP calls clarified: IAP commands are not supported for flash-less parts. See Section 5.8 “IAP commands”. For flashless parts only: Unique part ID is stored in OTP bank 0, word 2 and readable at memory location 0x4004 5008. See Section 3.1 and Table 9 “OTP memory description (OTP base address 0x4004 5000)”. For secure parts only: Chapter 7 “LPC18xx Boot ROM for secure parts” added. For secure parts only: AES DMA request lines added. See Table 92, Table 252, and Table 272. Boot ROM chapter split into two chapters for secure and non-secure parts. See Chapter 4 “LPC18xx Boot ROM” and Chapter 7 “LPC18xx Boot ROM for secure parts”. Description of USB0_DM and USB1_DM pins corrected: These pins do not contain an internal pull-up. See Table 381 and Table 443. Section 4.1.1 “Determine the boot code version” added. 	

Revision history ...continued

Rev	Date	Description
Modifications:		<ul style="list-style-type: none"> • Signal polarity of signals EMC_CKEOUT and EMC_DQMOUT corrected in Table 346 “EMC pin description”. Both signals are active HIGH. • Corrected remark for bits MODE3, RFCLK, and FBCLK in Table 335 “SPIFI control register (CTRL, address 0x4000 3000) bit description”: MODE3, RFCLK, and FBCLK should not all be 1, because in this case there is no final falling edge on SCK on which to sample the last data bit of the frame. • Bit 4 changed from Reserved to SEE (System Error Enable) in register USBINTR_D and USBINTR_H . See Table 395 and Table 396. • Bit 4 changed from Reserved to SEI in register USBSTS_D and USBSTS_H. See Table 393 and Table 394. • Bit 4 changed from Reserved to SEE (System Error Enable) register USBINTR_D and USBINTR_H. See Table 456 and Table 457. • Bit 4 changed from Reserved to SEI register USBSTS_D and USBSTS_H. See Table 454 and Table 455. • Added Section 23.11, System error. • Removed BUS_RST from Table 153. • Added a remark on how to read the FLADJ register in Section 10.4.10 and Section 10.4.11. • Added text: The USART3 boot mode is not supported for LPC18Sxx parts. See Section 4.1, Table 15, Table 16, and Section 7.1

Revision history ...continued

Rev	Date	Description
2.5	20140127	LPC18xx user manual
Modifications:		<ul style="list-style-type: none"> • C_CAN CLKDIV register description corrected and clock divider values updated. See Table 1011. • Priorities of the EMC SDRAM ports added. See Section 21.4. • Table 14 “OTP function allocation” updated. • Condition for the CAN PCLK added: PCLK < 50 MHz. See Section 42.2. • VBUS connection requirement for self-powered USB0 added to Section 22.5.1 “Requirements for connecting the USB0_VBUS/USB1_VBUS signal”. • Section 35.7.1 “Register read procedure” updated for reading the RTC registers after wake-up. • RTC_ALARM pin description corrected (Table 802 “RTC pin description”). This pin is not a 1.8 V pin. • Read-only status bits for EMC clock divider register configuration register added. See Table 146 “CCU1 branch clock configuration register (CLK_M3_EMCDIV_CFG, addresses 0x4005 1478) bit description”. • Description of the WAKEUP bits expanded in the CCU branch clock configuration and status registers. See Section 12.5.3 “CCU1/2 branch clock configuration registers” and Section 12.5.4 “CCU1/2 branch clock status registers”. • Bit RUN_N added to CCU branch clock status registers. See Section 12.5.4 “CCU1/2 branch clock status registers”. • ARM Cortex-M3 core version added. See Section 1.2 “Features”. • Statement added: Only write to the RTC registers when the 32 kHz oscillator is running. See Section 35.2. Same for Alarm timer. See Section 33.2. • MII availability clarified: Ethernet MII not available on LQFP144 and TFBGA100 parts. See Section 25.1 “How to read this chapter”. • Timer input and output connections clarified in Section 29.2 and Figure 35 “Connections between GIMA and peripherals”. • Section 42.7.5.1.1 “Calculating the C_CAN bit rate” added.
2.4	20131017	LPC18xx user manual
Modifications:		<ul style="list-style-type: none"> • AES ROM driver function table offsets corrected. See Table 68 “Security API calls”. • Part MX25L8006EM2L-12G, MX25L8035E, MX25L1633E, MX25L3235E, MX25L6435E, MX25L12835F, MX25L25635F added to list of parts that can boot from SPIFI. See Table 19. • Figure 11 “Boot process for parts without flash” updated. • Reset values of EEPROM registers RWSTATE and WSTATE corrected. See Table 1032.
2.3	20130926	LPC18xx user manual
Modifications:		<ul style="list-style-type: none"> • BASE_APLL_CLK renamed to BASE_AUDIO_CLK in Chapter 9 “LPC18xx Configuration Registers (CREG)”, Chapter 11 “LPC18xx Clock Generation Unit (CGU)”, Chapter 12 “LPC18xx Clock Control Unit (CCU)”, and Chapter 40 “LPC18xx I2S interface”. • AES speed corrected. See Section 6.2. • Bit description of register CREG5 corrected. Bits 10:0 changed to reserved. Use bits 11 for disabling JTAG. See Section 9.4.3 “CREG5 control register”. • Part IDs updated for all LPC1850/30/20/10 parts. See Table 39 and LPC1850/30/20/10 errata. • Description of the $\overline{\text{RESET}}$ pin updated in Table 166 and Table 167.

Revision history ...continued

Rev	Date	Description
Modifications:		<ul style="list-style-type: none"> • Description of the SDIS bit updated in for USB0 stream mode in Table 410/Table 411 and for USB1 stream mode in Table 471/Table 472. • Updated description of access types to the USB descriptors. See Table 421 “Endpoint capabilities and characteristics” and Table 425 “dTD token”. • Use of EMC_CLK pins clarified for SDRAM devices. See Section 21.2. • Pin description of pins SD_VOLT[2:0] updated in Table 274. • Add bits 20 (BOD reset) and 21 (reset after wake-up from deep power-down) to the event router registers. See Table 72, Table 75 to Table 83, and Section 13.5.1 “Determine the cause of a core reset”. • Table 183 “SD/MMC delay register (SDDELAY, address 0x4008 6D80) bit description” added. • USB driver code listing corrected. See Section 24.5 “USB API”. • Register RESET_EXT_STAT4 removed. See Table 152. • SDRAM address mappings added in Table 364. • Device MX25L6435EM2I-10G added to Table 18 “QSPI devices supported by the boot code and the SPIFI API”. • Table 4 “Ordering options (parts with on-chip flash)” corrected. ULPI not available on 144-pin and 100-pin packages. • Editorial updates to Section 4.3.5 “Boot image creation” and Figure 13 “Image encryption flow” added. • Editorial edits to Chapter 6 “LPC18xx Security API”. Section “CMAC using AES hardware acceleration” removed. • Section 11.2.1 “Configuring the BASE_M3_CLK for high operating frequencies” corrected to ensure safe operation of the clock ramping procedure. • Figures and tables in Section 40.7.2 “I2S operating modes” corrected. • Table 39 “LPC18xx part identification numbers” description of word1 corrected. • Part LPC1850FBD208 removed. • OTP memory size available for general-purpose use corrected. See Section 1.2 and Table 7. • Details about encryption of the image header added in Section 4.3.4 “Boot image header format”. • Figure 11 “Boot process for parts without flash” corrected. SPI(SSP) boot requires image header. • Bit description of Table 300 “Debounce Count Register (DEBNCE, address 0x4000 4064) bit description” updated. Host clock is the SD_CLK clock. • Security features updates. FIPS compliancy added. See Section 6.2. • Section 28.4.3 “SCT Example” updated. • Figure 103 “Repetitive Interrupt Timer (RIT) block diagram” corrected. • ISP mode added to Figure 11 “Boot process for parts without flash”. • Chapter “LPC18xx API General error codes” added.
2.2	20130125	LPC18xx user manual.
Modifications:		<ul style="list-style-type: none"> • GPIO group interrupt wake-up from power-down modes corrected in Section 16.3.2. Only wake-up from sleep mode supported. • Section 4.3.5.4.1 “Supported QSPI devices” moved to Chapter 4 “LPC18xx Boot ROM”. • SPIFI register map and register descriptions added in Chapter 19 “LPC18xx SPI Flash Interface (SPIFI)”. • Bit description of Table 924 “CAN error counter (EC, address 0x400E 2008 (C_CAN0) and 0x400A 4008 (C_CAN1)) bit description” corrected. • Bit clock calculation and bit description corrected in Section 41.6.1.4 “CAN bit timing register”.

Revision history ...continued

Rev	Date	Description
2.1	20121203	LPC18xx user manual. <ul style="list-style-type: none"> • Description of ADC pins on digital/analog input pins changed. Each input to the ADC is connected to ADC0 and ADC1. See Table 117, Table 118, Table 959, and Section 14.1. • Description of extra status bits added to Table 498 “DMA Status register (DMA_STAT, address 0x4001 1014) bit description”. • Use of lower SPIFI memory clarified. See Table 280 “SPIFI flash memory map”. • Description of DAC DMA_ENA bit clarified in Table 973 “D/A Control register (CTRL - address 0x400E 1004) bit description”. • Pseudo-code for PLL registers updated by code snippets from LPC18xx sample code in Chapter 10. • Reset delay clock cycles explained in Section 12.4.1 “RGU reset control register”. • Section 19.6 “Supported QSPI devices” updated. • Part S25FL129P0XNFI01 added to the list of devices supported by the SPIFI boot ROM driver.
2	20121012	LPC18xx user manual. <p>Modifications:</p> <ul style="list-style-type: none"> • Statement about the connection between sampling pin P2_7 and the watchdog timer overflow bit is incorrect and was removed in Section 44.4.1 “Sampling of pin P2_7” and Figure 164. • IRC accuracy corrected for flash-based parts in Section 1.2. • Description of the I2C mask registers clarified in Section 40.7.10. • Description of the I2C slave address updated in Section 40.7.8. • Flash-based parts LPC183x, LPC182x, LPC181x added. • SCT alias register locations corrected in Table 578. • SCT with dither engine added for flash-based parts. See Chapter 27 “LPC18xx State Configurable Timer (SCT) with dither engine”. • UART1 TER register location and bit description corrected. See Section 37.6.17. • Section 24.6.2 “MAC Frame filter register” updated to include hash filter option. • Section 24.7.1 “Hash filter” with examples added. • Polarity of the DMACSYNC bit in the GPDMA SYNC register corrected (see Table 215). • OTP API function table corrected. Location 0x1C is reserved. See Table 11. • SPIFI data rate and maximum clock corrected to SPIFI_CLK = 104 MHz and 52 MB/s. • The following changes were made on the TFBGA180 pinout in Table 117: <ul style="list-style-type: none"> – P1_13 moved from ball D6 to L8. – P7_5 moved from ball C7 to A7. – PF_4 moved from ball L8 to D6. – $\overline{\text{RESET}}$ moved from ball B7 to C7. – RTCX2 moved from ball A7 to B7. – Ball G10 changed from VSS to VDDIO. • EMC Configuration register, bit 8 changed to reserved. See “EMC Configuration register (CONFIG - address 0x4000 5008) bit description”.

Revision history ...continued

Rev	Date	Description
Modifications:		<ul style="list-style-type: none"> • DMA mux control register bit descriptions corrected. See Table 39. • ETM time stamping feature not implemented. See Chapter 46 “LPC18xx JTAG, Serial Wire Debug (SWD), and trace functions”. • Bit 0 in the RGU RESET_STATUS0 (Table 105) register changed to reserved. Section 12.5.1 “Determine the cause of a core reset” added. • Micron part N25Q256 removed from the list of devices supported by the SPIFI boot ROM driver. See Table 282 “Supported QSPI devices”. • Section 20.6.5 “Dynamic Memory Refresh Timer register” register description updated. • Description of the Motor control PWM INVDC bit updated in Table 664 “MCPWM Control read address (CON - 0x400A 0000) bit description”. • Description of the Alarm timer PRESETVAL bit updated in Table 729 “Preset value register (PRESET - 0x4004 0004) bit description”.
1.6	20120903	LPC18xx user manual.
Modifications:		<ul style="list-style-type: none"> • CLKMODE3 feature removed from SCT. Bit value CLKMODE = 0x3 changed to reserved in Table 577 “SCT configuration register (CONFIG - address 0x4000 0000) bit description”. • SSP0 boot pin functions corrected in Table 12 and Table 13. Pin P3_3 = SSP0_SCK, pin P3_6 = SSP0_SSEL, pin P3_7 = SSP0_MISO, pin P3_8 = SSP0_MOSI. • Details for GIMA clock synchronization added in Section 15.3.2. • RESET_EXT_STATUS0 register removed in Chapter 12. • Reset value of BASE_SAFE_CLK register changed to R (read-only) in Table 74. • Reset delay values corrected in Figure 30 “RGU Reset structure”. • POR reset value of the event router STATUS register corrected. See Table 24 and Table 30. • USB boot mode updated: 12 MHz external crystal required. See Section 4.3.5.5. • Reset priorities for POR and CORE_RST updated in Chapter 12 “LPC18xx Reset Generation Unit (RGU)”. • Reset values updated in Table 102 “Register overview: RGU (base address: 0x4005 3000)”. • IAP invoke call entry pointer clarified in Section 43.8 “IAP commands”. • EMC memory data and control lines clarified for the LQFP208 package in Table 283. • Figure 10 updated to include boot process for AES capable parts. • Editorial updates.
1.5	20120710	LPC18xx user manual.
Modifications:		<ul style="list-style-type: none"> • Description of USB CDC device class updated in Table 449 “USBD_CDC_API class structure” and Table 450 “USBD_CDC_INIT_PARAM class structure”. • AES only available for LPC18Sxx parts. • Table 14 “Boot image header use” added. • Section 21.11 “USB power optimization” updated. • Section 22.7.1 “Susp_CTRL module for USB1” added for USB1. • Bank, Row, Column SDRAM addressing added in Table 307.

Revision history ...continued

Rev	Date	Description
1.4	20120607	LPC18xx user manual.
Modifications:		<ul style="list-style-type: none"> • Description of CCU auto mode updated (see Section 11.5.3). • Parameter t_b updated in Table 16. • Examples updated for ISP “Copy RAM to flash” and ISP “Go” commands in Table 948 and Table 952. • Syncflash removed from Chapter 20. • Parts LPC1837/33 added. • Maximum power consumption in the USB Suspended state corrected according to USB 2.0 ECN specification (Section 21.11.1). • Programming procedure for the SDRAM mode register added in Section 20.7.5. • Clock ramp-up procedures for core clock added in Section 10.2.1. • Parameters for ISP/IAP command “Copy RAM to flash” updated (Table 951 and Table 964). • Flash accelerator register waitstate values added (see Table 40 and Table 41). • Description of ISP/IAP read part id command updated (see Table 955 and Table 967). • Description of the event router outputs updated (see Section 7.3). • LQFP100 package removed. • Part IDs corrected in Table 956; also see <i>Errata note ES_LPC18X0_A</i>.
1.3	20120502	LPC18xx user manual.
Modifications:		<ul style="list-style-type: none"> • Part IDs corrected in Table 955. • OTP memory bank 0 changed to reserved. • Support for AES encryption added (see Table 16; parts LPC18Sxx only). • Hardware IP checksum feature removed from ethernet block. • USB frame length adjust register added (see Table 44 and Table 45); for parts with on-chip flash only). • Flash accelerator control registers added (see Table 39 and Table 40). • Support for SAMPLE pin added to the CREG0 register (Table 35). • Read option removed from EEPROM CMD register (Table 985). • Add definition of page size in Section 43.5. • Corrected SRAM address for ISP use in Section 43.4.5.7. • Update description of bit 0 in the USBSTS_D and bit 5:0 in ENDPTCOMPLETE registers of USB0/1. • Update procedure Section 21.10.8.1.2 “Setup packet handling using the trip wire mechanism”. • TFBGA package pinout added in Chapter 13. • Timer/SCT cross-connections updated for CTOUT_1, CTOUT_4, CTOUT_5, CTOUT_9, CTOUT_10, CTOUT_12, and CTOUT_13 in Chapter 13, Table 574, and Section 27.5. • Polarity of bit OUTSEL in the SCT EVCTRL register swapped (see Table 600). • Description of STOP_I/H bits in the SCT CTRL register updated (see Table 577). • Description of BOD wake-up corrected in Table 21.

Revision history ...continued

Rev	Date	Description
1.2	20120329	LPC18xx user manual.
Modifications:		<ul style="list-style-type: none"> • Chapter 18 updated. • EEPROM memory location corrected in Figure 5. • EEPROM memory access explained (Section 2.3.4). • SDRAM low-power mode removed in Chapter 20. • Motorcontrol PWM hardware noise filtering removed. • Description of the QEI register VEL corrected. • ISP commands for flash parts updated in Chapter 43. • Chapter 38 updated. • Appendix describing parts LPC18xx Rev '-' removed. • References to parts LPC18xx Rev '-' removed throughout the document. • Remove condition RTC_ALARM = LOW on reset for entering debug mode. • Ethernet chapter updated: PPS and auxiliary timestamp features removed. • Chapter 34 added. • Reset value of bit ETB in the ETBCFG register changed to one (see Table 41). • Connection of USB0_VBUS/USB1_VBUS signals added (Section 21.5.1). • Description of ADC GDR register updated (Section 41.6.2). • UART1 FIFOLVL register removed. • Pin reset states updated in Table 113 and Table 114. • SCT register map updated in Table 570. • Changed maximum clock frequency for SWD and ETB access to 120 MHz in Chapter 45. • Reduced and normal power modes removed in Chapter 9.
1.1	20111212	Preliminary LPC18xx user manual.
Modifications:		<ul style="list-style-type: none"> • SPIFI boot pins added to Table 12 and Table 13. • Description of SPIFI boot mode added (Section 4.3.5.4). • Chapter 19 added. • PMUCON register removed in Chapter 8. • Ethernet time stamp registers added (see Table 455). • Reset value corrected for WWDT and CREG resets in Table 100. • Maximum operating frequency corrected. • Editorial updates. • Use of SPIFI memory areas explained in Table 275.
1	20111202	Preliminary LPC18xx user manual.

Contact information

For more information, please visit: <http://www.nxp.com>

For sales office addresses, please send an email to: salesaddresses@nxp.com

1.1 Introduction

The LPC18xx are ARM Cortex-M3 based microcontrollers for embedded applications. The ARM Cortex-M3 is a next generation core that offers system enhancements such as low power consumption, enhanced debug features, and a high level of support block integration.

The LPC18xx operate at CPU frequencies of up to 180 MHz. The ARM Cortex-M3 CPU incorporates a 3-stage pipeline and uses a Harvard architecture with separate local instruction and data buses as well as a third bus for peripherals. The ARM Cortex-M3 CPU also includes an internal prefetch unit that supports speculative branching.

The LPC18xx include up to 200 kB of on-chip SRAM data memory (flashless parts) or up to 136 kB of on-chip SRAM and up to 1 MB of flash (parts with on-chip flash), 16 kB EEPROM, a quad SPI Flash Interface (SPIFI), a State Configurable Timer (SCT) subsystem, two High-speed USB controllers, Ethernet, LCD, an external memory controller, and multiple digital and analog peripherals.

Remark: This user manual describes parts LPC1850/30/20/10 (flashless parts) and the flash-based LPC18xx parts.

See [Section 49.2 “References”](#) for additional documentation.

1.2 Features

- Processor core
 - ARM Cortex-M3 processor (core version r2p1), running at frequencies of up to 180 MHz.
 - ARM Cortex-M3 built-in Memory Protection Unit (MPU) supporting eight regions.
 - ARM Cortex-M3 built-in Nested Vectored Interrupt Controller (NVIC).
 - Non-maskable Interrupt (NMI) input.
 - JTAG and Serial Wire Debug, serial trace, eight breakpoints, and four watch points.
 - ETM and ETB support.
 - System tick timer.
- On-chip memory (flashless parts LPC1850/30/20/10)
 - Up to 200 kB SRAM total for code and data use.
 - Two 32 kB SRAM blocks with separate bus access. Both SRAM blocks can be powered down individually.
 - 64 kB ROM containing boot code and on-chip software drivers.
 - 64 bit+ 256 bit One-Time Programmable (OTP) memory for general-purpose customer use. For secure parts, 256 bit OTP memory is used for key storage.
- On-chip memory (parts with on-chip flash)
 - Up to 1 MB total dual bank flash memory with flash accelerator.

- In-System Programming (ISP) and In-Application Programming (IAP) via on-chip boot loader software.
- Up to 136 kB SRAM for code and data use.
- Two 32 kB SRAM blocks with separate bus access. Both SRAM blocks can be powered down individually.
- 64 kB ROM containing boot code and on-chip software drivers.
- 32 bit One-Time Programmable (OTP) memory for general-purpose customer use.
- 16 kB EEPROM.
- Clock generation unit
 - Crystal oscillator with an operating range of 1 MHz to 25 MHz.
 - 12 MHz internal RC oscillator trimmed to 1 % (flashless parts) or 2 % (flash-based parts) accuracy.
 - Ultra-low power RTC crystal oscillator.
 - Three PLLs allow CPU operation up to the maximum CPU rate without the need for a high-frequency crystal. The second PLL is dedicated to the High-speed USB, the third PLL can be used as audio PLL.
 - Clock output.
- Serial interfaces:
 - Quad SPI Flash Interface (SPIFI) with 1-, 2-, or 4-bit data at rates up to 52 MB per second.
 - 10/100T Ethernet MAC with RMI and MII interfaces and DMA support for high throughput at low CPU load. Support for IEEE 1588 time stamping/advanced time stamping (IEEE 1588-2008 v2).
 - One High-speed USB 2.0 Host/Device/OTG interface with DMA support and on-chip PHY.
 - One High-speed USB 2.0 Host/Device interface with DMA support, on-chip full-speed PHY and ULPI interface to external high-speed PHY.
 - USB interface electrical test software included in ROM USB stack.
 - Four 550 UARTs with DMA support: one UART with full modem interface; one UART with IrDA interface; three USARTs support synchronous mode and a smart card interface conforming to ISO7816 specification.
 - Two C_CAN 2.0B controllers with one channel each.
 - Two SSP controllers with FIFO and multi-protocol support. Both SSPs with DMA support.
 - One Fast-mode Plus I²C-bus interface with monitor mode and with open-drain I/O pins conforming to the full I²C-bus specification. Supports data rates of up to 1 Mbit/s.
 - One standard I²C-bus interface with monitor mode and standard I/O pins.
 - Two I²S interfaces with DMA support, each with one input and one output.
- Digital peripherals:
 - External Memory Controller (EMC) supporting external SRAM, ROM, NOR flash, and SDRAM devices.

- LCD controller with DMA support and a programmable display resolution of up to 1024H × 768V. Supports monochrome and color STN panels and TFT color panels; supports 1/2/4/8 bpp CLUT and 16/24-bit direct pixel mapping.
- SD/MMC card interface.
- Eight-channel General-Purpose DMA (GPDMA) controller can access all memories on the AHB and all DMA-capable AHB slaves.
- Up to 164 General-Purpose Input/Output (GPIO) pins with configurable pull-up/pull-down resistors and open-drain modes.
- GPIO registers are located on the AHB for fast access. GPIO ports have DMA support.
- State Configurable Timer (SCT) subsystem on AHB.
- Four general-purpose timer/counters with capture and match capabilities.
- One motor control PWM for three-phase motor control.
- One Quadrature Encoder Interface (QEI).
- Repetitive Interrupt timer (RI timer).
- Windowed watchdog timer.
- Ultra-low power Real-Time Clock (RTC) on separate power domain with 256 bytes of battery powered backup registers.
- Event recorder with 3 inputs to record event identification and event time; can be battery powered. The event recorder is available on parts with on-chip flash only.
- Alarm timer; can be battery powered.
- Digital peripherals available on flash-based parts LPC18xx only:
 - Event monitor in the RTC power domain.
- Analog peripherals:
 - One 10-bit DAC with DMA support and a data conversion rate of 400 kSamples/s.
 - Two 10-bit ADCs with DMA support and a data conversion rate of 400 kSamples/s.
- Security (LPC18Sxx parts only):
 - Hardware-based AES security engine programmable through an on-chip API.
 - Two 128 bit secure OTP memories for AES key storage and customer use.
 - Random number generator (RNG) accessible through AES API.
- Unique ID for each device.
- Power:
 - Single 3.3 V (2.2 V to 3.6 V) power supply with on-chip internal voltage regulator for the core supply and the RTC power domain.
 - RTC power domain can be powered separately by a 3 V battery supply.
 - Four reduced power modes: Sleep, Deep-sleep, Power-down, and Deep power-down.
 - Processor wake-up from Sleep mode via wake-up interrupts from various peripherals.

- Wake-up from Deep-sleep, Power-down, and Deep power-down modes via external interrupts and interrupts generated by battery powered blocks in the RTC power domain.
 - Brownout detect with four separate thresholds for interrupt and forced reset.
 - Power-On Reset (POR).
- Available as 144-pin and 208-pin LQFP packages and as 100-pin, 180-pin, and 256-pin LPGA packages.

1.3 Ordering information (flashless parts LPC1850/30/20/10)

Table 1. Ordering information

Type number	Package		
	Name	Description	Version
LPC1850FET256	LBGA256	Plastic low profile ball grid array package; 256 balls; body 17 × 17 × 1 mm	SOT740-2
LPC1850FET180	TFBGA180	Thin fine-pitch ball grid array package; 180 balls	SOT570-3
LPC18S50FET256	LBGA256	Plastic low profile ball grid array package; 256 balls; body 17 × 17 × 1 mm	SOT740-2
LPC18S50FET180	TFBGA180	Thin fine-pitch ball grid array package; 180 balls	SOT570-3
LPC1830FET256	LBGA256	Plastic low profile ball grid array package; 256 balls; body 17 × 17 × 1 mm	SOT740-2
LPC1830FET180	TFBGA180	Thin fine-pitch ball grid array package; 180 balls	SOT570-3
LPC1830FET100	TFBGA100	Plastic thin fine-pitch ball grid array package; 100 balls; body 9 × 9 × 0.7 mm	SOT926-1
LPC1830FBD144	LQFP144	Plastic low profile quad flat package; 144 leads; body 20 × 20 × 1.4 mm	SOT486-1
LPC18S30FET256	LBGA256	Plastic low profile ball grid array package; 256 balls; body 17 × 17 × 1 mm	SOT740-2
LPC18S30FET100	TFBGA100	Plastic thin fine-pitch ball grid array package; 100 balls; body 9 × 9 × 0.7 mm	SOT926-1
LPC18S30FBD144	LQFP144	Plastic low profile quad flat package; 144 leads; body 20 × 20 × 1.4 mm	SOT486-1
LPC1820FET100	TFBGA100	Plastic thin fine-pitch ball grid array package; 100 balls; body 9 × 9 × 0.7 mm	SOT926-1
LPC1820FBD144	LQFP144	Plastic low profile quad flat package; 144 leads; body 20 × 20 × 1.4 mm	SOT486-1
LPC1810FET100	TFBGA100	Plastic thin fine-pitch ball grid array package; 100 balls; body 9 × 9 × 0.7 mm	SOT926-1
LPC1810FBD144	LQFP144	Plastic low profile quad flat package; 144 leads; body 20 × 20 × 1.4 mm	SOT486-1
LPC18S10FET100	TFBGA100	Plastic thin fine-pitch ball grid array package; 100 balls; body 9 × 9 × 0.7 mm	SOT926-1
LPC18S10FBD144	LQFP144	Plastic low profile quad flat package; 144 leads; body 20 × 20 × 1.4 mm	SOT486-1

Table 2. Ordering options (flashless parts)

Type number	Total SRAM	LCD	Ethernet	USB0 (Host, Device, OTG)	USB1 (Host, Device)/ULPI interface	ADC channels	PWM	QEI	GPIO	Package
LPC1850FET256	200 kB	yes	yes	yes	yes/yes	8	yes	yes	164	LBGA256
LPC1850FET180	200 kB	yes	yes	yes	yes/yes	8	yes	yes	118	TFBGA180
LPC18S50FET256	200 kB	yes	yes	yes	yes/yes	8	yes	yes	164	LBGA256
LPC18S50FET180	200 kB	yes	yes	yes	yes/yes	8	yes	yes	118	TFBGA180
LPC1830FET256	200 kB	no	yes	yes	yes/yes	8	yes	yes	164	LBGA256
LPC1830FET180	200 kB	no	yes	yes	yes/yes	8	yes	yes	118	TFBGA180
LPC1830FET100	200 kB	no	yes	yes	yes/no	4	no	no	49	TFBGA100

Table 2. Ordering options (flashless parts)

Type number	Total SRAM	LCD	Ethernet	USB0 (Host, Device, OTG)	USB1 (Host, Device)/ ULPI interface	ADC channels	PWM	QEI	GPIO	Package
LPC1830FBD144	200 kB	no	yes	yes	yes/no	8	yes	no	83	LQFP144
LPC18S30FET256	200 kB	no	yes	yes	yes/yes	8	yes	yes	164	LBGA256
LPC18S30FET100	200 kB	no	yes	yes	yes/no	4	no	no	49	TFBGA100
LPC18S30FBD144	200 kB	no	yes	yes	yes/no	8	yes	no	83	LQFP144
LPC1820FET100	168 kB	no	no	yes	no	4	no	no	49	TFBGA100
LPC1820FBD144	168 kB	no	no	yes	no	8	yes	no	83	LQFP144
LPC1810FET100	136 kB	no	no	no	no	4	no	no	49	TFBGA100
LPC1810FBD144	136 kB	no	no	no	no	8	yes	no	83	LQFP144
LPC18S10FET100	136 kB	no	no	no	no	4	no	no	49	TFBGA100
LPC18S10FBD144	136 kB	no	no	no	no	8	yes	no	83	LQFP144

1.4 Ordering information (parts with on-chip flash)

Table 3. Ordering information (parts with on-chip flash)

Type number	Package		Version
	Name	Description	
LPC1857FET256	LBGA256	Plastic low profile ball grid array package; 256 balls; body 17 × 17 × 1 mm	SOT740-2
LPC1857JET256	LBGA256	Plastic low profile ball grid array package; 256 balls; body 17 × 17 × 1 mm	SOT740-2
LPC1857JBD208	LQFP208	Plastic low profile quad flat package; 208 leads; body 28 × 28 × 1.4 mm	SOT459-1
LPC18S57JET256	LBGA256	Plastic low profile ball grid array package; 256 balls; body 17 × 17 × 1 mm	SOT740-2
LPC18S57JBD208	LQFP208	Plastic low profile quad flat package; 208 leads; body 28 × 28 × 1.4 mm	SOT459-1
LPC1853FET256	LBGA256	Plastic low profile ball grid array package; 256 balls; body 17 × 17 × 1 mm	SOT740-2
LPC1853JET256	LBGA256	Plastic low profile ball grid array package; 256 balls; body 17 × 17 × 1 mm	SOT740-2
LPC1853JBD208	LQFP208	Plastic low profile quad flat package; 208 leads; body 28 × 28 × 1.4 mm	SOT459-1
LPC1837FET256	LBGA256	Plastic low profile ball grid array package; 256 balls; body 17 × 17 × 1 mm	SOT740-2
LPC1837JET256	LBGA256	Plastic low profile ball grid array package; 256 balls; body 17 × 17 × 1 mm	SOT740-2
LPC1837JBD144	LQFP144	Plastic low profile quad flat package; 144 leads; body 20 × 20 × 1.4 mm	SOT486-1
LPC1837JET100	TFBGA100	Plastic thin fine-pitch ball grid array package; 100 balls; body 9 × 9 × 0.7 mm	SOT926-1
LPC18S37JBD144	LQFP144	Plastic low profile quad flat package; 144 leads; body 20 × 20 × 1.4 mm	SOT486-1
LPC18S37JET100	TFBGA100	Plastic thin fine-pitch ball grid array package; 100 balls; body 9 × 9 × 0.7 mm	SOT926-1
LPC1833FET256	LBGA256	Plastic low profile ball grid array package; 256 balls; body 17 × 17 × 1 mm	SOT740-2
LPC1833JET256	LBGA256	Plastic low profile ball grid array package; 256 balls; body 17 × 17 × 1 mm	SOT740-2
LPC1833JBD144	LQFP144	Plastic low profile quad flat package; 144 leads; body 20 × 20 × 1.4 mm	SOT486-1
LPC1833JET100	TFBGA100	Plastic thin fine-pitch ball grid array package; 100 balls; body 9 × 9 × 0.7 mm	SOT926-1
LPC1827JBD144	LQFP144	Plastic low profile quad flat package; 144 leads; body 20 × 20 × 1.4 mm	SOT486-1
LPC1827JET100	TFBGA100	Plastic thin fine-pitch ball grid array package; 100 balls; body 9 × 9 × 0.7 mm	SOT926-1
LPC1825JBD144	LQFP144	Plastic low profile quad flat package; 144 leads; body 20 × 20 × 1.4 mm	SOT486-1
LPC1825JET100	TFBGA100	Plastic thin fine-pitch ball grid array package; 100 balls; body 9 × 9 × 0.7 mm	SOT926-1

Table 3. Ordering information (parts with on-chip flash)

Type number	Package		Version
	Name	Description	
LPC1823JBD144	LQFP144	Plastic low profile quad flat package; 144 leads; body 20 × 20 × 1.4 mm	SOT486-1
LPC1823JET100	TFBGA100	Plastic thin fine-pitch ball grid array package; 100 balls; body 9 × 9 × 0.7 mm	SOT926-1
LPC1822JBD144	LQFP144	Plastic low profile quad flat package; 144 leads; body 20 × 20 × 1.4 mm	SOT486-1
LPC1822JET100	TFBGA100	Plastic thin fine-pitch ball grid array package; 100 balls; body 9 × 9 × 0.7 mm	SOT926-1
LPC1817JBD144	LQFP144	Plastic low profile quad flat package; 144 leads; body 20 × 20 × 1.4 mm	SOT486-1
LPC1817JET100	TFBGA100	Plastic thin fine-pitch ball grid array package; 100 balls; body 9 × 9 × 0.7 mm	SOT926-1
LPC1815JBD144	LQFP144	Plastic low profile quad flat package; 144 leads; body 20 × 20 × 1.4 mm	SOT486-1
LPC1815JET100	TFBGA100	Plastic thin fine-pitch ball grid array package; 100 balls; body 9 × 9 × 0.7 mm	SOT926-1
LPC1813JBD144	LQFP144	Plastic low profile quad flat package; 144 leads; body 20 × 20 × 1.4 mm	SOT486-1
LPC1813JET100	TFBGA100	Plastic thin fine-pitch ball grid array package; 100 balls; body 9 × 9 × 0.7 mm	SOT926-1
LPC1812JBD144	LQFP144	Plastic low profile quad flat package; 144 leads; body 20 × 20 × 1.4 mm	SOT486-1
LPC1812JET100	TFBGA100	Plastic thin fine-pitch ball grid array package; 100 balls; body 9 × 9 × 0.7 mm	SOT926-1

Table 4. Ordering options (parts with on-chip flash)

Type number	Flash total	Flash bank A	Flash bank B	Total SRAM	LCD	Ethernet	USB0 (Host, Device, OTG)	USB1 (Host, Device)/ ULPI interface	PWM	QEI	ADC channels	Temperature range ^[1]	GPIO
LPC1857FET256	1 MB	512 kB	512 kB	136 kB	yes	yes	yes	yes/yes	yes	yes	8	F	164
LPC1857JET256	1 MB	512 kB	512 kB	136 kB	yes	yes	yes	yes/yes	yes	yes	8	J	164
LPC1857JBD208	1 MB	512 kB	512 kB	136 kB	yes	yes	yes	yes/yes	yes	yes	8	J	142
LPC18S57JET256	1 MB	512 kB	512 kB	136 kB	yes	yes	yes	yes/yes	yes	yes	8	J	164
LPC18S57JBD208	1 MB	512 kB	512 kB	136 kB	yes	yes	yes	yes/yes	yes	yes	8	J	142
LPC1853FET256	512 kB	256 kB	256 kB	136 kB	yes	yes	yes	yes/yes	yes	yes	8	F	164
LPC1853JET256	512 kB	256 kB	256 kB	136 kB	yes	yes	yes	yes/yes	yes	yes	8	J	164
LPC1853JBD208	512 kB	256 kB	256 kB	136 kB	yes	yes	yes	yes/yes	yes	yes	8	J	142
LPC1837FET256	1 MB	512 kB	512 kB	136 kB	no	yes	yes	yes/yes	yes	yes	8	F	164
LPC1837JET256	1 MB	512 kB	512 kB	136 kB	no	yes	yes	yes/yes	yes	yes	8	J	164
LPC1837JBD144	1 MB	512 kB	512 kB	136 kB	no	yes	yes	yes/no	yes	no	8	J	83
LPC1837JET100	1 MB	512 kB	512 kB	136 kB	no	yes	yes	yes/no	no	no	4	J	49
LPC18S37JBD144	1 MB	512 kB	512 kB	136 kB	no	yes	yes	yes/no	yes	no	8	J	83
LPC18S37JET100	1 MB	512 kB	512 kB	136 kB	no	yes	yes	yes/no	no	no	4	J	49
LPC1833FET256	512 kB	256 kB	256 kB	136 kB	no	yes	yes	yes/yes	yes	yes	8	F	164
LPC1833JET256	512 kB	256 kB	256 kB	136 kB	no	yes	yes	yes/yes	yes	yes	8	J	164
LPC1833JBD144	512 kB	256 kB	256 kB	136 kB	no	yes	yes	yes/no	yes	no	8	J	83
LPC1833JET100	512 kB	256 kB	256 kB	136 kB	no	yes	yes	yes/no	no	no	4	J	49

Table 4. Ordering options (parts with on-chip flash)

Type number	Flash total	Flash bank A	Flash bank B	Total SRAM	LCD	Ethernet	USB0 (Host, Device, OTG)	USB1 (Host, Device)/ ULPI interface	PWM	QEI	ADC channels	Temperature range ^[1]	GPIO
LPC1827JBD144	1 MB	512 kB	512 kB	136 kB	no	no	yes	no/no	yes	no	8	J	83
LPC1827JET100	1 MB	512 kB	512 kB	136 kB	no	no	yes	no/no	no	no	4	J	49
LPC1825JBD144	768 kB	384 kB	384 kB	136 kB	no	no	yes	no/no	yes	no	8	J	83
LPC1825JET100	768 kB	384 kB	384 kB	136 kB	no	no	yes	no/no	no	no	4	J	49
LPC1823JBD144	512 kB	256 kB	256 kB	104 kB	no	no	yes	no/no	yes	no	8	J	83
LPC1823JET100	512 kB	256 kB	256 kB	104 kB	no	no	yes	no/no	no	no	4	J	49
LPC1822JBD144	512 kB	512 kB	0 kB	104 kB	no	no	yes	no/no	yes	no	8	J	83
LPC1822JET100	512 kB	512 kB	0 kB	104 kB	no	no	yes	no/no	no	no	4	J	49
LPC1817JBD144	1 MB	512 kB	512 kB	136 kB	no	no	no	no/no	yes	no	8	J	83
LPC1817JET100	1 MB	512 kB	512 kB	136 kB	no	no	no	no/no	no	no	4	J	49
LPC1815JBD144	768 kB	384 kB	384 kB	136 kB	no	no	no	no/no	yes	no	8	J	83
LPC1815JET100	768 kB	384 kB	384 kB	136 kB	no	no	no	no/no	no	no	4	J	49
LPC1813JBD144	512 kB	256 kB	256 kB	104 kB	no	no	no	no/no	yes	no	8	J	83
LPC1813JET100	512 kB	256 kB	256 kB	104 kB	no	no	no	no/no	no	no	4	J	49
LPC1812JBD144	512 kB	512 kB	0 kB	104 kB	no	no	no	no/no	yes	no	8	J	83
LPC1812JET100	512 kB	512 kB	0 kB	104 kB	no	no	no	no/no	no	no	4	J	49

[1] J = - 40 °C to +105 °C; F = - 40 °C to +85 °C.

1.5 Block diagram (flashless parts LPC1850/30/20/10)

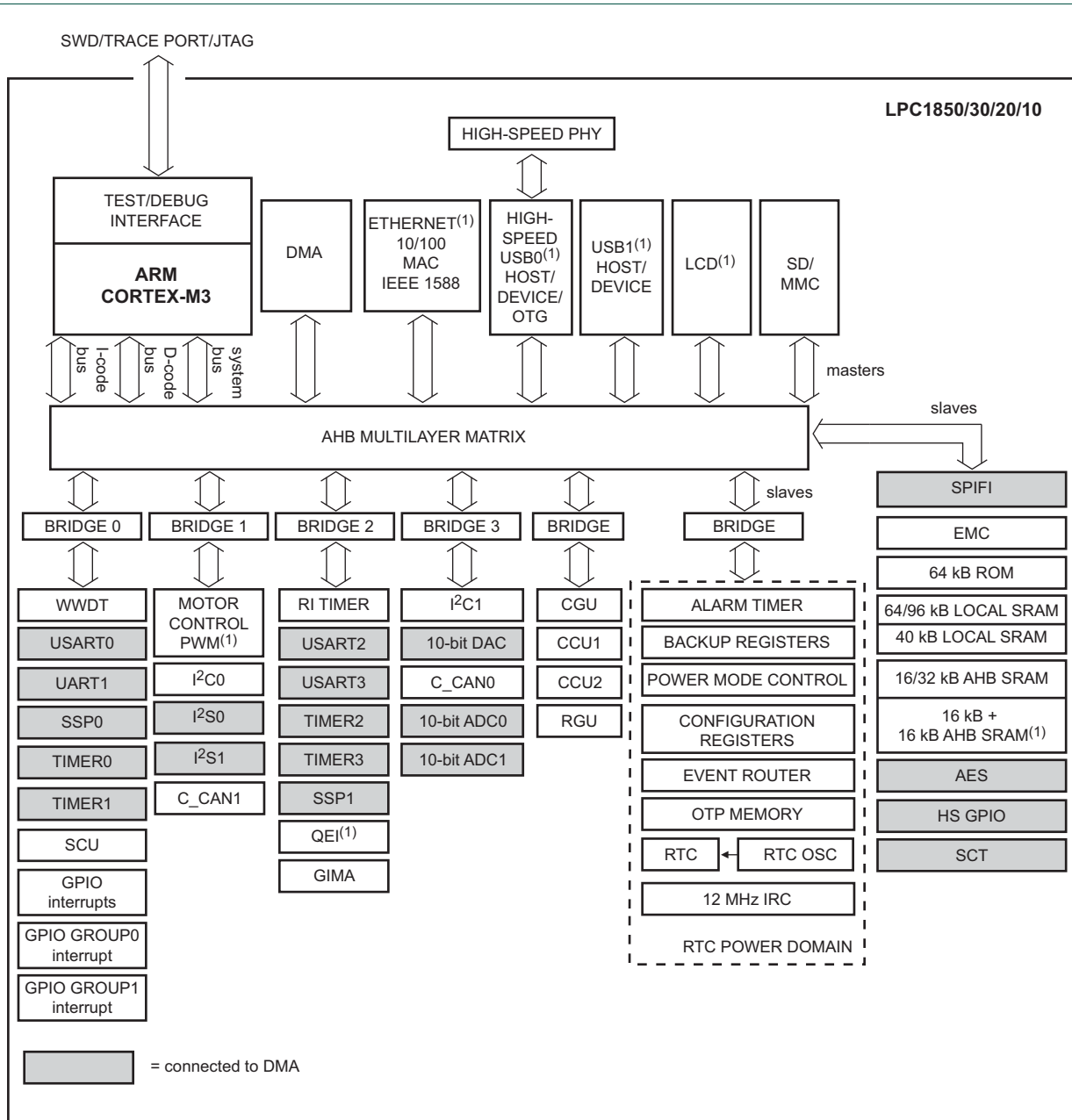

002aaf218

AES available on LPC18Sxx parts only.

Fig 1. LPC18xx Block diagram (flashless parts)

1.6 Block diagram (parts with on-chip flash)

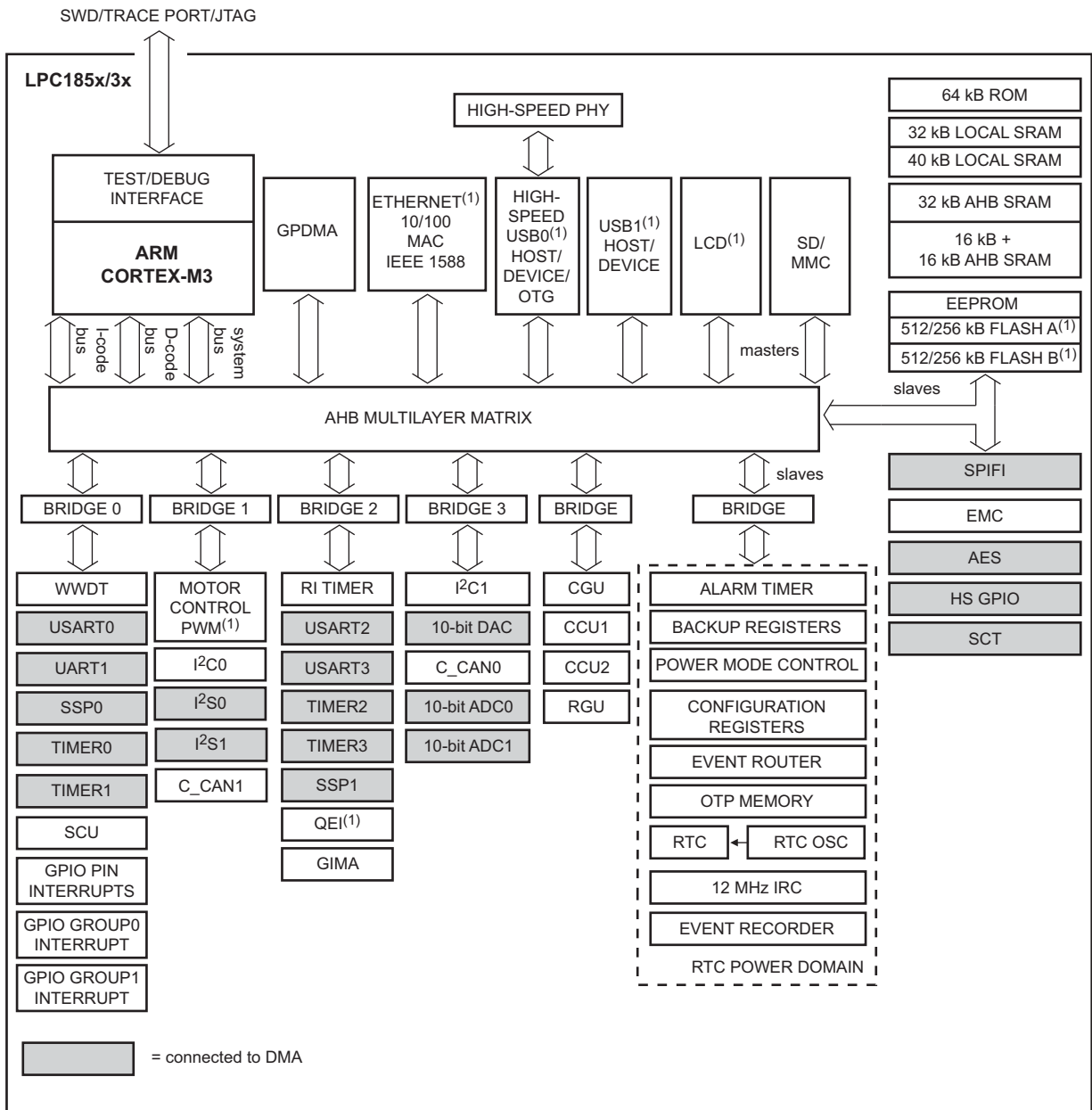

AES available on LPC18Sxx parts only.

(1) Not available on all parts (see Table 4).

Fig 2. LPC185x/3x block diagram (parts with on-chip flash)

2.1 How to read this chapter

The following peripherals and memory blocks are only available on selected parts and are reserved otherwise:

- Ethernet: available only on LPC185x/3x.
- USB0: available only on LPC185x/3x/2x.
- USB1: available only on LPC185x/3x.
- LCD: available only on parts LPC185x.
- SRAM: see [Table 5](#).
- Flash: see [Table 6](#).

2.2 Basic configuration

In the CREG block (see [Table 95](#)), select the interface to access the 16 kB block of RAM located at address 0x2000 C000. This RAM memory block can be accessed either by the Embedded Trace Buffer (ETB), or it can be used as normal SRAM on the AHB bus.

Remark: When the ETB is used, the 16 kB memory space at 0x2000 C000 must not be used by any other process.

2.3 Memory configuration

2.3.1 On-chip static RAM

The LPC18xx support up to 136 kB SRAM (parts with on-chip flash) or up to 200 kB SRAM (flashless parts LPC1850/30/20/10) with separate bus master access for higher throughput and individual power control for low power operation (see [Figure 7](#) and [Figure 8](#)).

When the Embedded Trace Buffer is used (see ETBCFG register, [Table 95](#)), the 16 kB memory space at 0x2000 C000 must not be used by any other process.

Table 5. LPC18xx SRAM configuration

Part	Local SRAM 0x1000 0000	Local SRAM [1] 0x1008 0000	AHB SRAM 0x2000 0000	AHB SRAM 0x2000 8000	AHB SRAM /ETB SRAM[2] 0x2000 C000	
LPC1850	96 kB	40 kB	32 kB	16 kB	16 kB	Figure 3
LPC1830	96 kB	40 kB	32 kB	16 kB	16 kB	Figure 3
LPC1820	96 kB	40 kB	16 kB	-	16 kB	Figure 3
LPC1810	64 kB	40 kB	16 kB	-	16 kB	Figure 3
LPC185x	32 kB	40 kB	32 kB	16 kB	16 kB	Figure 5
LPC183x	32 kB	40 kB	32 kB	16 kB	16 kB	Figure 5
LPC1827	32 kB	40 kB	32 kB	16 kB	16 kB	Figure 5
LPC1825	32 kB	40 kB	32 kB	16 kB	16 kB	Figure 5
LPC1823	32 kB	40 kB	16 kB	-	16 kB	Figure 5
LPC1822	32 kB	40 kB	16 kB	-	16 kB	Figure 5
LPC1817	32 kB	40 kB	32 kB	16 kB	16 kB	Figure 5
LPC1815	32 kB	40 kB	32 kB	16 kB	16 kB	Figure 5
LPC1813	32 kB	40 kB	16 kB	-	16 kB	Figure 5
LPC1812	32 kB	40 kB	16 kB	-	16 kB	Figure 5

[1] Top 8 kB at 0x1008 8000 remain powered on in Sleep, Deep-sleep, and Power-down modes (see [Table 100](#)).

[2] To configure SRAM for AHB or ETB access, see [Table 95](#).

2.3.2 Bit banding

Bit-banding offers efficient bit accesses. Bits in the bit-band region (0x2000 0000 to 0x2010 0000 and 0x4000 0000 to 0x40100000) can be accessed in the so-called alias region at 0x2200 0000 and 0x4200 0000. Reads return the respective bit from the bit-band region. Writes perform an atomic read-modify-write on the respective bit of the bit-band region. For details, see the *ARM Cortex-M3 technical reference manual*.

Remark: Bit banding can not be used with the MAC_RWAKE_FRFLT register (see [Section 26.6.10](#)).

Remark: Although the EEPROM is mapped in a bit-banding capable region, attempts to write access the EEPROM in the bit-banding aliased memory space will not result in a bit write

2.3.3 On-chip flash

The available flash configuration for the LPC185x/3x/2x/1x is shown in [Table 6](#). An integrated flash accelerator maximizes performance for use with the two fast AHB buses.

The flash memory interface includes an intelligent buffering scheme. It can be beneficial to locate code and static data over the two flash memories to enable parallel code and data access or to avoid that interrupts corrupt buffer content. The buffers are aligned on 32-byte boundaries.

Table 6. LPC185x/3x/2x/1x Flash configuration

Part	Flash bank A 256 kB	Flash bank A 128 kB	Flash bank A 128 kB	Flash bank B 256 kB	Flash bank B 128 kB	Flash bank B 128 kB	Total flash
	starting at address:						
	0x1A00 0000	0x1A04 000	0x1A06 0000	0x1B00 0000	0x1B04 0000	0x1B06 0000	
LPC18x7	yes	yes	yes	yes	yes	yes	1 MB
LPC18x5	yes	yes	no	yes	yes	no	768 kB
LPC18x3	yes	no	no	yes	no	no	512 kB
LPC18x2	yes	yes	yes	no	no	no	512 kB

2.3.4 On-chip EEPROM

The LPC185x/3x parts with flash also include a 16 kB EEPROM. The EEPROM is divided into 128 pages. The last EEPROM page is protected.

2.3.5 Memory retention in the Power-down modes

In Deep-sleep mode, all SRAM content is retained. At wake-up the system can restart immediately.

In Power-down mode, only the top 8 kB of SRAM block starting at 0x1008 0000 is retained - that is the upper 8 kB of the SRAM block starting at 0x1008 8000. All other SRAM content is lost. Common practice is to store the stack and other variables that need to be retained in this 8 kB memory space as well as code to restart the rest of the system.

In Deep power-down mode, no SRAM content is retained. Variables that need to be retained in deep power down can be stored in the 256-byte register file located in the RTC domain at 0x4004 1000.

2.3.6 Memory Protection Unit (MPU)

The MPU is an integral part of the ARM Cortex-M3 for memory protection and supported by all LPC18xx parts. The processor supports the standard ARMv7 Protected Memory System Architecture model. The MPU provides full support for:

- protection regions
- overlapping protection regions, with ascending region priority (7 = highest priority, 0 = lowest priority)
- access permissions
- exporting memory attributes to the system

MPU mismatches and permission violations invoke the programmable-priority MemManage fault handler. See the *ARMv7-M Architecture Reference Manual* for more information.

The access permission bits, TEX, C, B, AP, and XN, of the Region Access Control Register control access to the corresponding memory region. If an access is made to an area of memory without the required permissions, a permission fault is raised. For more information, see the *ARMv7-M Architecture Reference Manual*.

The MPU is used to enforce privilege rules, to separate processes, and to enforce access rules. For details on how to use the MPU and for the register description refer to the *ARM Cortex-M3 Technical Reference Manual*.

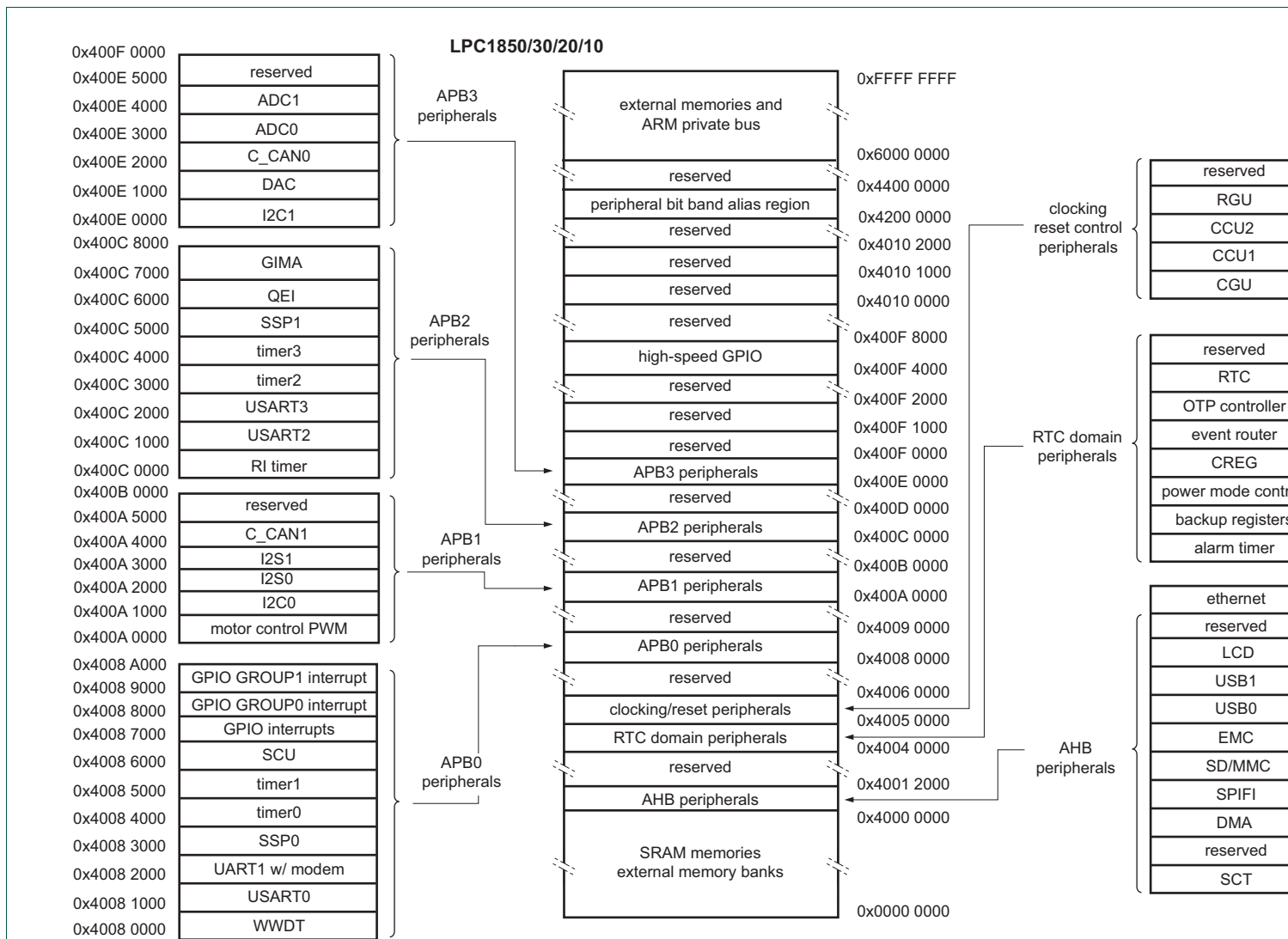

Fig 4. Memory map with peripherals - flashless parts LPC1850/30/20/10 (see Figure 3 for detailed addresses of memory blocks)

2.5 Memory map (parts with on-chip flash)

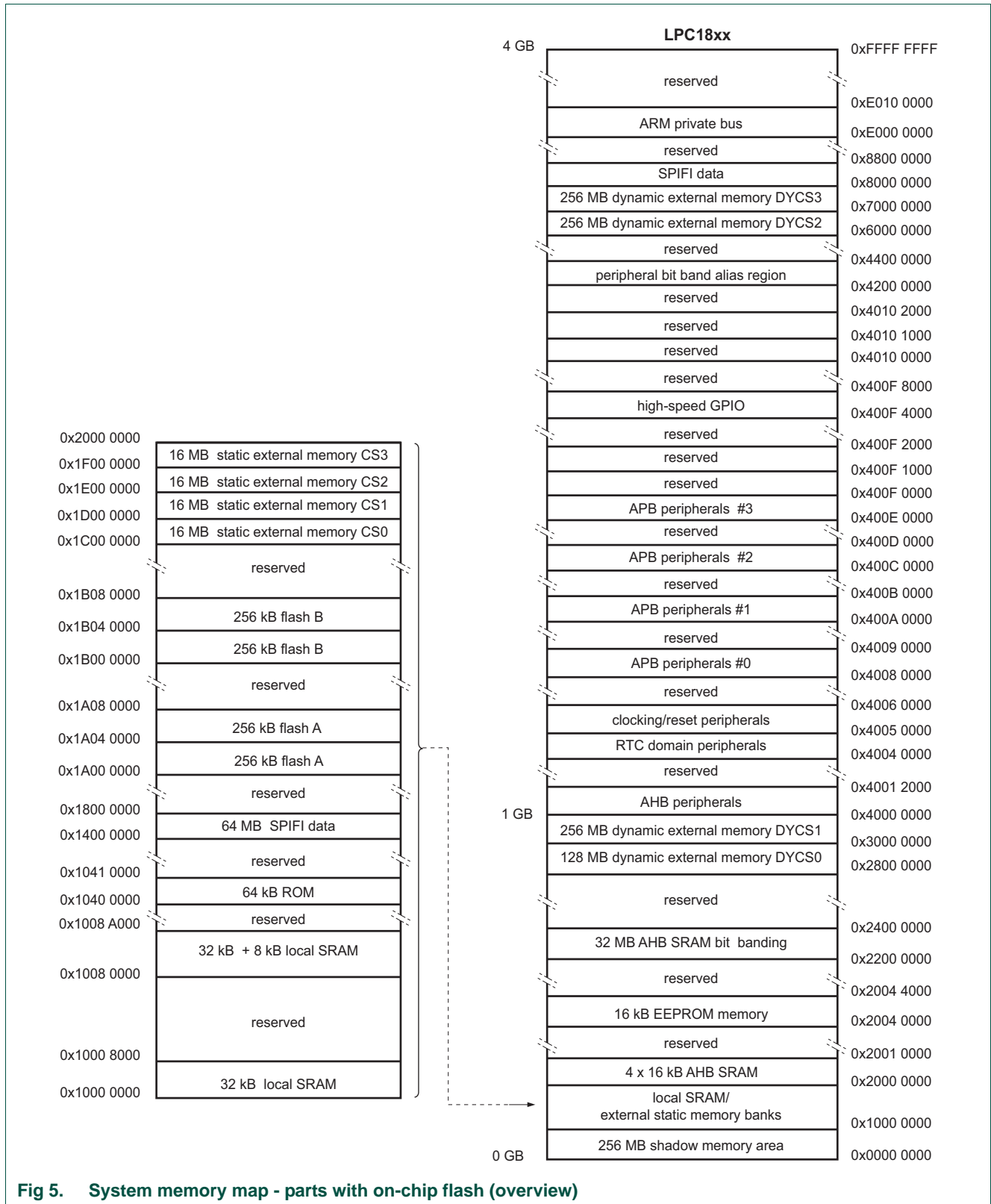
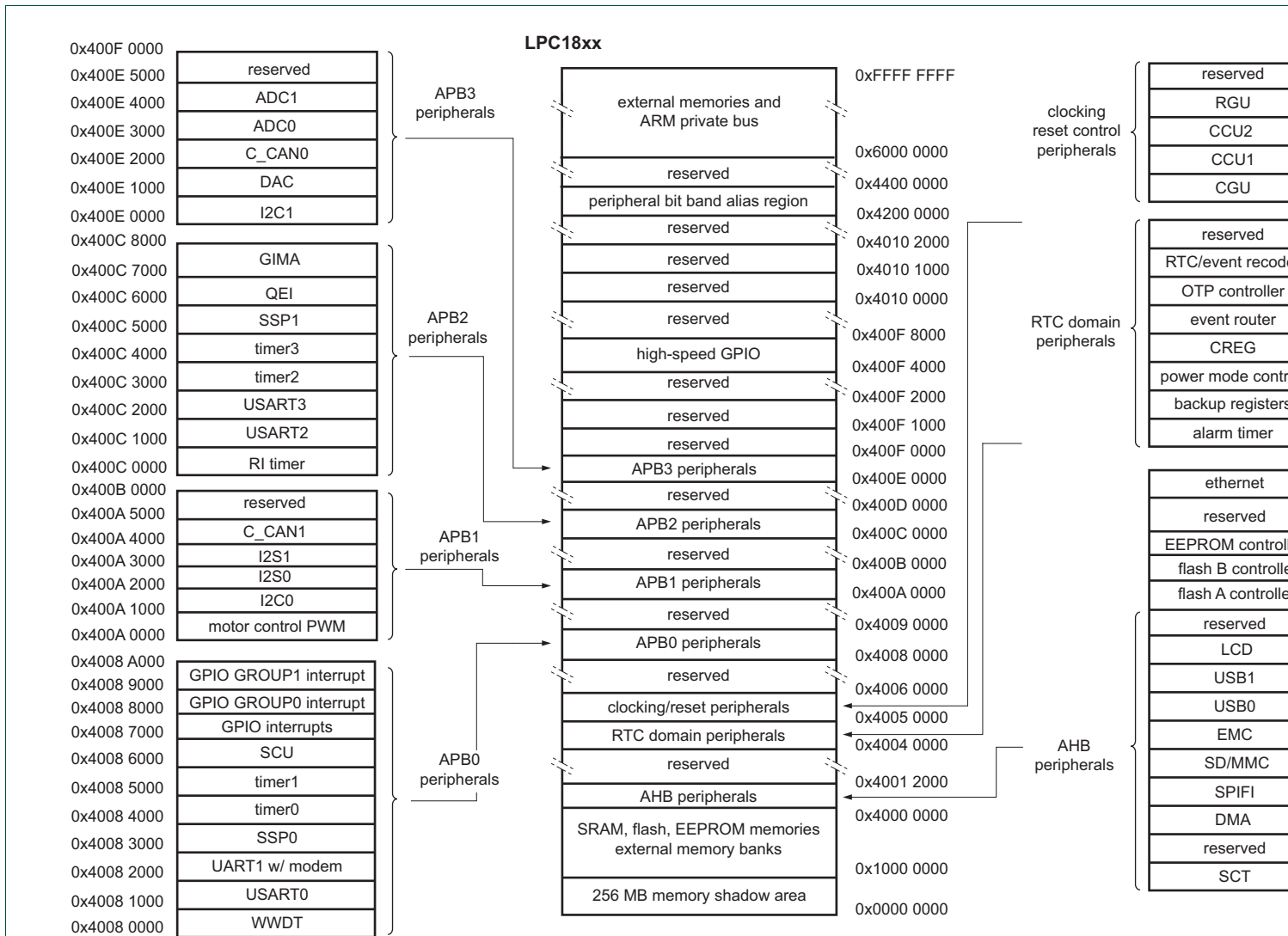

Fig 5. System memory map - parts with on-chip flash (overview)



(1) Not available on all parts (see Table 4).

Fig 6. Memory mapping - parts with on-chip flash (peripherals)

2.6 AHB multilayer matrix configuration

The multilayer AHB matrix enables all bus masters to access any embedded memory as well as external SPI flash memory connected to the SPIFI interface. When two or more bus masters try to access the same slave, a round robin arbitration scheme is used; each master takes turns accessing the slave in circular order. The access length is determined by the burst access length of the master. For the CPU, the burst size is 1, for the GPDMA, the burst size can be up to 8. To optimize CPU performance, low-latency code should be stored in a memory that is not accessed by other bus masters, especially masters that use a long burst size.

To optimize the CPU performance the ARM Cortex-M3 has three buses for Instruction (code) (I) access, Data (D) access, and System (S) access. The I- and D-bus access memory space is located below 0x2000 0000, the S-bus accesses the memory space starting from 0x2000 0000. When instructions and data are kept in separate memories, then code and data accesses can be done in parallel in one cycle. When code and data are kept in the same memory, then instructions that load or store data may take two cycles.

The LPC18xx peripherals are divided into AHB and APB peripherals. AHB peripherals such as the USB and ethernet controllers are directly connected to the AHB matrix. APB peripherals are connected to the AHB matrix via bus bridges.

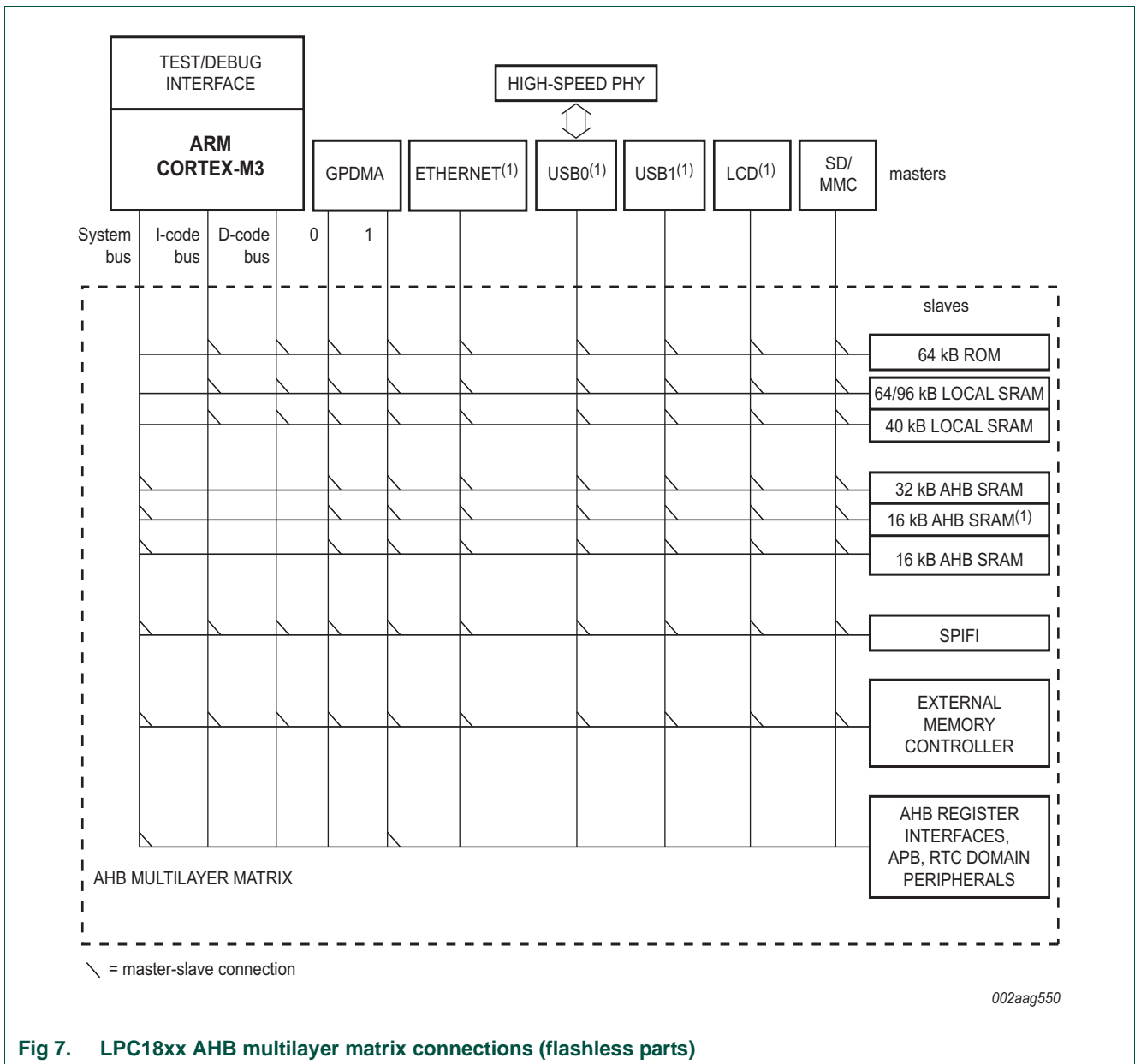

Fig 7. LPC18xx AHB multilayer matrix connections (flashless parts)

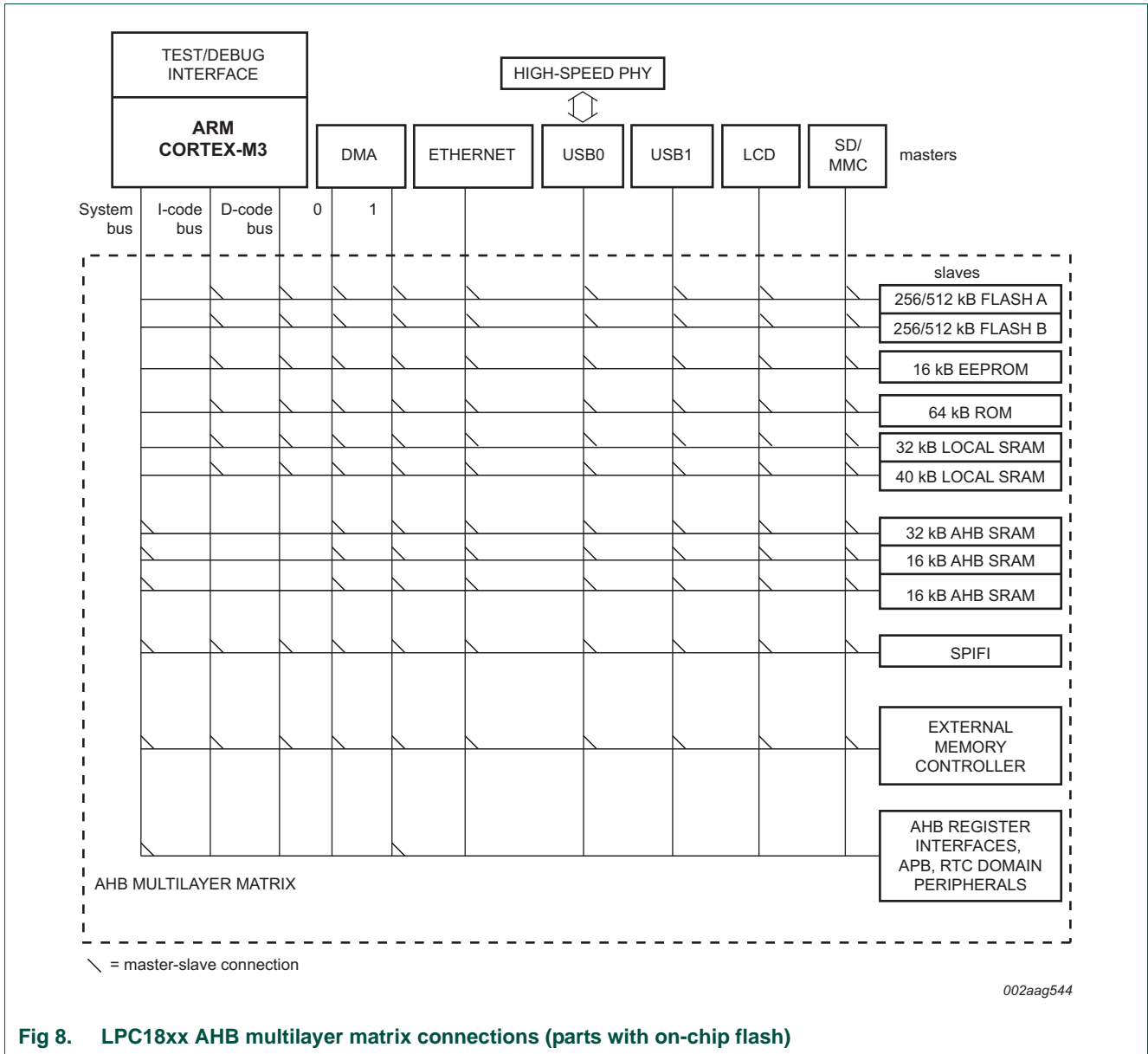

Fig 8. LPC18xx AHB multilayer matrix connections (parts with on-chip flash)

3.1 How to read this chapter

This chapter applies to all LPC18xx parts with the following exceptions:

- AES keys and AES support are available on LPC18Sxx parts only.
- The following bit must only be set for secure, flashless parts: JTAG_DISABLE in the OTP memory bank 3, word 0 (bit 31).
- For flashless parts only: The unique part ID can be read from OTP bank 0, words 0 to 3 at memory location 0x4004 5000. (For parts with on-chip flash, use the ISP/IAP calls to read the unique part ID.)

Different OTP API functions for programming the OTP banks are available depending on boot ROM revision. Software library functions are available on LPCWare.com to be used for programming OTP banks one and two when the OTP API functions are not available in ROM.

Table 7. OTP bank programming API functions available in ROM

OTP API name	Offset	Flashless parts LPC1850/ 30/20/ 10	Parts with flash; LPC18xx; die revision 'C'	Parts with flash; LPC18xx die revision 'A' and higher	Secure parts, flashless; LPC18S50/30/ 20/10
otp_ProgGP0	0x14	no	no	yes	use AES API aes_ProgramKey1
otp_ProgGP1	0x18	no	no	yes	use AES API aes_ProgramKey2
otp_ProgGP2	0x1C	no	no	yes	no
otp_ProgGP2_0	0x20	yes	yes	yes	yes
otp_ProgGP2_1	0x24	yes	yes	yes	yes
otp_ProgGP2_2	0x28	yes	yes	yes	yes

3.2 Features

- The OTP memory stores the following information:
 - User programmable are the boot source, the USB vendor and product ID, and the AES keys.
 - Unused fields can be used to store other data.
- API support for programming the OTP in Boot ROM provided.

3.3 General description

The OTP memory contains four memory banks of 128 bits each. The first memory bank (OTP bank 0) is reserved. The other three OTP banks are programmable. In non-secure parts, OTP banks 1 and 2 are available for general-purpose data. In secure parts, OTP banks 1 and 2 are used for AES keys. OTP bank 3 contains up to two user programmable configuration words and two more words for general-purpose use.

The virgin OTP state is all zeros. A zero value can be overwritten by a one, but a one in any of the OTP bits cannot be changed.

Programming the OTP requires a higher voltage than reading. The read voltage is generated internally. The programming voltage is supplied via pin VPP. The OTP controller automatically selects the correct voltage. If the VPP pin is not connected, then the OTP cannot be programmed. An API is provided to program data into the OTP.

The AES keys in the OTP memory used by secure parts are not readable by software.

Table 8. OTP content for secure and non-secure parts

OTP bank	Secure devices				Non-secure devices			
	Content	Encrypted	Software access	API	Content	Encrypted	Software access	API
0	Reserved	-	-	-	-	-	-	-
1	AES key 1 for secure boot image	yes	no	aes_ProgramKey1	User-defined; general purpose 0	no	yes	otp_ProgGP0
2	AES key 2 for data	no	no	aes_ProgramKey2	User-defined; general purpose 1	no	yes	otp_ProgGP1
3	Word 0: Customer control data	no	yes	otp_ProgBootSrc, otp_ProgJTAGDis	Word 0: Customer control data	no	yes	otp_ProgBootSrc
3	Word 1; general purpose word 0 or USB ID	no	yes	otp_ProgGP2 or otp_ProgGP2_0 or otp_ProgUSBID	Same as for secure devices			
3	Words 2 to 3: General purpose data in words 1/2.	no	yes	otp_ProgGP2 or otp_ProgGP2_1, otp_ProgGP2_2	Same as for secure devices			

3.4 Register description

Table 9. OTP memory description (OTP base address 0x4004 5000)

OTP bank	Word	Access	Address offset	Size	Description	Reference
0	0	Pre-programmed; cannot be changed by the user.	0x000	32 bit	First 32 bit word of the unique part ID for flashless parts. Reserved for parts with on-chip flash.	-
0	1	Pre-programmed; cannot be changed by the user.	0x004	32 bit	Second 32 bit word of the unique part ID for flashless parts. Reserved for parts with on-chip flash.	-
0	2	Pre-programmed; cannot be changed by the user.	0x008	32 bit	Third 32 bit word of the unique part ID for flashless parts. Reserved for parts with on-chip flash.	-
0	3	Pre-programmed; cannot be changed by the user.	0x00C	32 bit	Fourth 32 bit word of the unique part ID for flashless parts. Reserved for parts with on-chip flash.	-
1	0	User programmable; initial state = 0	0x010	32 bit	General purpose OTP memory 0, word 0, or AES key 1, word 0	-
1	1	User programmable; initial state = 0	0x014	32 bit	General purpose OTP memory 0, word 1, or AES0 key 1, word 1	-
1	2	User programmable; initial state = 0	0x018	32 bit	General purpose OTP memory 0, word 2, or AES0 key 1, word 2	-
1	3	User programmable; initial state = 0	0x01C	32 bit	General purpose OTP memory 0, word 3, or AES0 key 1, word 3	-
2	0	User programmable; initial state = 0	0x020	32 bit	General purpose OTP memory 1, word 0, or AES key 2, word 0	-
2	1	User programmable; initial state = 0	0x024	32 bit	General purpose OTP memory 1, word 1, or AES key 2, word 1	-
2	2	User programmable; initial state = 0	0x028	32 bit	General purpose OTP memory 1, word 2, or AES key 2, word 2	-
2	3	User programmable; initial state = 0	0x02C	32 bit	General purpose OTP memory 1, word 3, or AES key 2, word 3	-
3	0	User programmable; initial state = 0	0x030	32 bit	Customer control data	Table 10
3	1	User programmable; initial state = 0	0x034	32 bit	General purpose OTP memory 2, word 0, or USB ID	Table 11
3	2	User programmable; initial state = 0	0x038	32 bit	General purpose OTP memory 2, word 1	Table 12
3	3	User programmable; initial state = 0	0x03C	32 bit	General purpose OTP memory 2, word 2	Table 13

Table 10. OTP memory bank 3, word 0 - Customer control data (address offset 0x030)

Bit	Symbol	Value	Description
22:0	-	-	Reserved
23	USB_ID_ENABLE		Setting this bit allows to enable OTP defined USB vendor and product IDs. When enabled, the USB driver uses the USB_VENDOR_ID and USB_PRODUCT_ID values. If disabled, the NXP vendor ID (0x1FC9) and product ID (0x000C) is used.
		0	Disabled
		1	Enabled
24	-	-	Reserved
28:25	BOOT_SRC		Boot source selection in OTP. For details, see Table 15 .
		0000	External pins
		0001	UART0
		0010	SPIFI
		0011	EMC 8-bit
		0100	EMC 16-bit
		0101	EMC 32-bit
		0110	USB0
		0111	USB1
		1000	SPI (via SSP)
		1001	UART3
29	-		Reserved. Do not write to this bit.
30	-		Reserved. Do not write to this bit.
31	JTAG_DISABLE		If this bit set, JTAG cannot be enabled by software and remains disabled.

Table 11. OTP memory bank 3, word 1 - General purpose OTP memory 2, word 0, or USB ID (address offset 0x034)

Bit	Symbol	Description
15:0	USB_VENDOR_ID	If USB_ID_ENABLE bit not set, it is used as general purpose
31:16	USB_PRODUCT_ID	OTP memory 2, word 0, GP2_0.

Table 12. OTP memory bank 3, word 2 - General purpose OTP memory 2, word 1 (address offset 0x038)

Bit	Symbol	Description
31:0	GP2_1	General purpose OTP memory 2, word 1. GP2_1.

Table 13. OTP memory bank 3, word 3 - General purpose OTP memory 2, word 2 (address offset 0x03C)

Bit	Symbol	Description
31:0	GP2_2	General purpose OTP memory 2, word 2. GP2_2.

3.5 OTP API

The OTP memory is controlled through a set of simple API calls located in the LPC18xx ROM.

The API calls to the ROM are performed by executing functions which are pointed to by pointer within the ROM driver table.

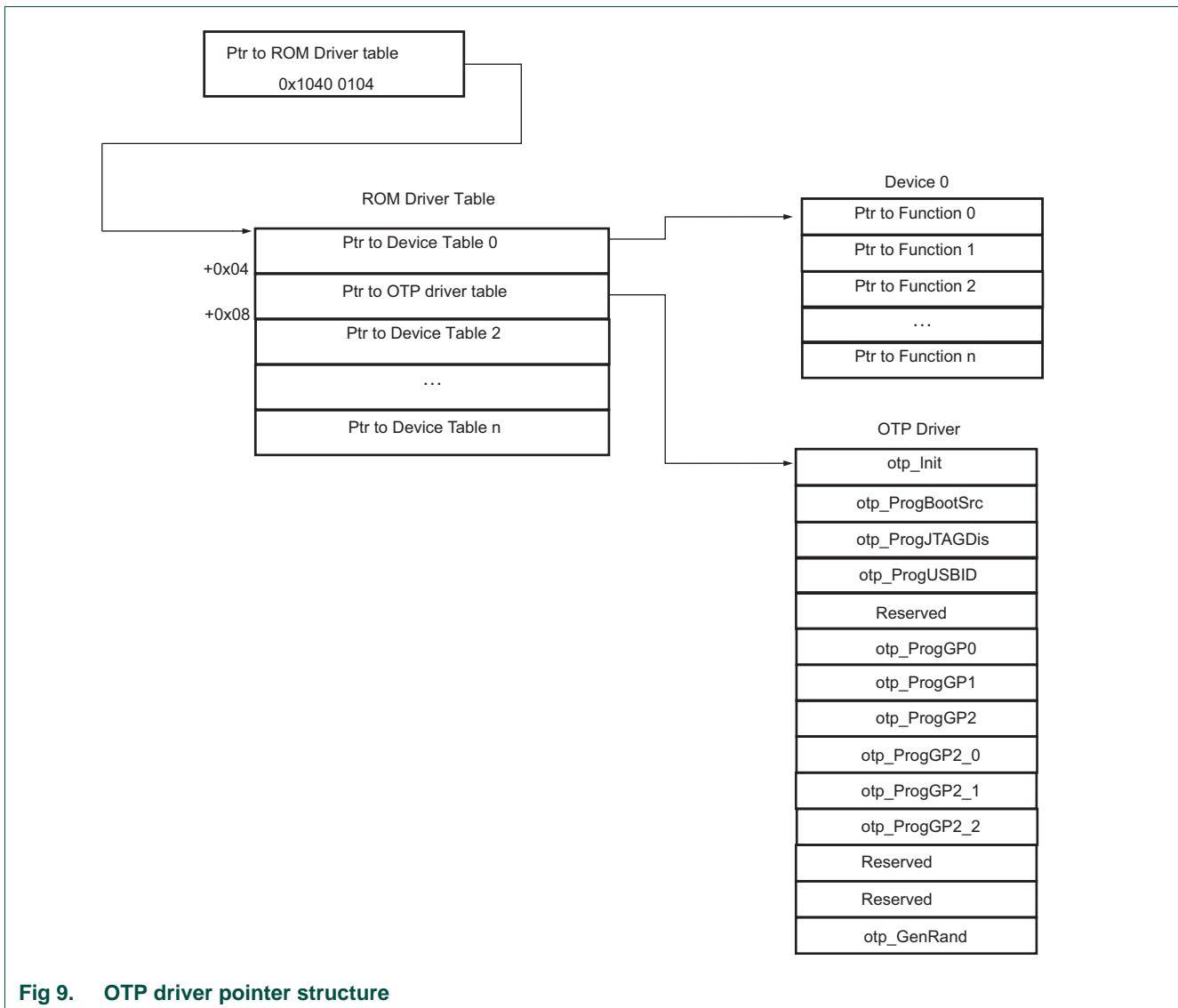

3.5.1 OTP function allocation

Remark: See [Section 3.1](#) for availability of OTP function for different boot ROM versions.

Table 14. OTP function allocation

Function	Offset	Description	OTP bank programmed	OTP memory name
otp_Init	0x00	Initializes OTP controller. Parameter - void Return- unsigned: see the general error codes.	-	-
otp_ProgBootSrc	0x04	Programs boot source in OTP bank 3, word 0 (customer control data). Parameter - unsigned src Return- unsigned: see the general error codes.	3; word 0	Customer control data
otp_ProgJTAGDis	0x08	Set JTAG_DISABLE bit in OTP bank 3, word 0 (customer control data). Use only when the device is AES capable. Setting the JTAG_DISABLE bit disables the JTAG permanently. Parameter - void Return- unsigned: see the general error codes.	3; word 0	Customer control data
otp_ProgUSBID	0x0C	Programs USB_ID. Parameter - unsigned prod_id, unsigned vend_id Return- unsigned: see the general error codes.	3; word 1	Customer control data
-	0x10	Reserved.	-	-
otp_ProgGP0	0x14	Programs the general purpose OTP memory GP0. Use only if the device is not AES capable. The data parameter consists of four 32-bit words, one for each word in the memory bank. The mask parameter contains a mask for each of the words written. Mask bits that are set to 1 allow a write to the corresponding OTP bit. Parameter - unsigned *data, unsigned *mask Return- unsigned: see the general error codes.	1 (entire bank)	General purpose memory 0; words 0 to 3
otp_ProgGP1	0x18	Programs the general purpose OTP memory GP1. Use only if the device is not AES capable. The data parameter consists of four 32-bit words, one for each word in the memory bank. The mask parameter contains a mask for each of the words written. Mask bits that are set to 1 allow a write to the corresponding OTP bit. Parameter - unsigned *data, unsigned *mask Return- unsigned: see the general error codes.	2 (entire bank)	General purpose memory 1; words 0 to 3
otp_ProgGP2	0x1C	Programs the general purpose OTP memory GP2 (however, writes to word 0, which contains customer control data are ignored). Use for customer-specific data. The data parameter consists of four 32-bit words, one for each word in the memory bank. The mask parameter contains a mask for each of the words written. Mask bits that are set to 1 allow a write to the corresponding OTP bit. Parameter - unsigned *data, unsigned *mask Return- unsigned: see the general error codes.	3 (word 1, word 2, word 3); writes to word 0 are ignored	General purpose memory 2; words 1 to 3;

Table 14. OTP function allocation

Function	Offset	Description	OTP bank programmed	OTP memory name
otp_ProgGP2_0	0x20	<p>Programs the general purpose OTP memory GP2 word 0. Use for customer-specific data. The data parameter is one 32-bit word. The mask parameter contains a mask for the word written. Mask bits that are set to 1 allow a write to the corresponding OTP bit.</p> <p>Remark: This function can only be used if the USB ID is not programmed. Otherwise, error code ERR_OTP_USB_ID_ENABLED is returned.</p> <p>Parameter - unsigned data, unsigned mask Return- unsigned: see the general error codes.</p>	3 (word 1)	General purpose memory 2, word 0
otp_ProgGP2_1	0x24	<p>Programs the general purpose OTP memory GP2 word 1. Use for customer-specific data. The data parameter is one 32-bit word. The mask parameter contains a mask for the word written. Mask bits that are set to 1 allow a write to the corresponding OTP bit.</p> <p>Parameter - unsigned data, unsigned mask Return- unsigned: see the general error codes.</p>	3 (word 2)	General purpose memory 2, word 1
otp_ProgGP2_2	0x28	<p>Programs the general purpose OTP memory GP2 word 2. Use for customer-specific data. The data parameter is one 32-bit word. The mask parameter contains a mask for the word written. Mask bits that are set to 1 allow a write to the corresponding OTP bit.</p> <p>Parameter - unsigned data, unsigned mask Return- unsigned: see the general error codes.</p>	3 (word 3)	General purpose memory 2, word 2
-	0x2C	Reserved.	-	-
-	0x30	Reserved.	-	-
otp_GenRand	0x34	<p>Generate new random number using the hardware Random Number Generator (RNG).</p> <p>Parameter - void Return- unsigned: see the general error codes.</p>	-	-

3.5.1.1 OTP API error codes

```

ERR_OTP_BASE = 0x00070000,
/*0x00070001*/ ERR_OTP_WR_ENABLE_INVALID = ERR_OTP_BASE+1
/*0x00070002*/ ERR_OTP_SOME_BITS_ALREADY_PROGRAMMED
/*0x00070003*/ ERR_OTP_ALL_DATA_OR_MASK_ZERO
/*0x00070004*/ ERR_OTP_WRITE_ACCESS_LOCKED
/*0x00070005*/ ERR_OTP_READ_DATA_MISMATCH
/*0x00070006*/ ERR_OTP_USB_ID_ENABLED
/*0x00070007*/ ERR_OTP_ETH_MAC_ENABLED
/*0x00070008*/ ERR_OTP_AES_KEYS_ENABLED
/*0x00070009*/ ERR_OTP_ILLEGAL_BANK

```

For general error codes, see [Chapter 3 “LPC18xx One-Time Programmable \(OTP\) memory and API”](#).

4.1 How to read this chapter

This chapter applies to all LPC18xx parts. AES support is available on LPC18Sxx parts only.

Flash-based parts boot from on-chip flash by default (see [Chapter 5](#)), but other boot modes described in this chapter are also supported. The UART boot mode is only supported for flashless parts. The secure boot from USART3 is not supported for LPC18Sxx parts.

4.1.1 Determine the boot code version

For parts with on-chip flash, the boot code version can be determined using ISP or IAP calls. See [Table 40 "ISP Read Boot Code version number command"](#) and [Table 51 "IAP Read Boot Code version number command"](#).

For flashless parts, use ISP to read the boot code version number (see [Table 40](#)) or read memory location 0x1040 7FFC which encodes the boot code version as follows:

Value 0x000B 000n at location 0x1040 7FFC reads as boot code version 11.n.

4.2 Features

The boot ROM memory includes the following features:

- ROM memory size is 64 kB.
- Supports booting from UART interfaces, external static memory such as NOR flash, SPI flash, quad SPI flash, high-speed USB (USB0), and USB1.
- Includes API for OTP programming.
- Includes USB drivers.
- ISP mode for loading data to on-chip SRAM and execute code from on-chip SRAM.

AES capable parts also support (LPC18Sxx only):

- CMAC authentication on the boot image.
- Secure booting from an encrypted image.
- Supports development mode for booting from a plain text image.
- API for AES programming.

All software drivers and APIs located in ROM are written in Thumb mode and can be used on both M0 and M4 cores.

4.3 Functional description

The internal ROM memory is used to store the boot code. After a reset, the ARM processor will start its code execution from this memory.

The ARM core is configured to start executing code, upon reset, with the program counter being set to the value 0x0000 0000. The LPC18xx contains a shadow pointer that allows areas of memory to be mapped to address 0x0000 0000. The default value of the shadow pointer is 0x1040 0000, ensuring that the code contained in the boot ROM is executed at reset.

For flash-based parts, the LPC18xx boots from internal flash by default (boot pin P2_7 is HIGH). If the boot pin is sampled LOW on reset, the boot source is determined by the setting of the OTP or the states of pins P2_9, P2_8, P1_2, and P1_1. For details see [Figure 10](#).

For flash-based and flashless parts alike, several external sources are available for booting depending on the values of the OTP bits BOOT_SRC (see [Section 3.4](#)). If the OTP memory is not programmed or the BOOT_SRC bits are all zero, the boot mode is determined by the states of the boot pins P2_9, P2_8, P1_2, and P1_1.

Table 15. Boot mode when OTP BOOT_SRC bits are programmed

Boot mode	BOOT_SRC bit 3	BOOT_SRC bit 2	BOOT_SRC bit 1	BOOT_SRC bit 0	Description
Boot pins	0	0	0	0	Boot source is defined by the reset state of P1_1, P1_2, P2_9, and P2_8 pins. See Table 16 .
USART0	0	0	0	1	Boot from device connected to USART0 using pins P2_0 and P2_1. For flash parts, enter UART ISP mode.
SPIFI	0	0	1	0	Boot from Quad SPI flash connected to the SPIFI interface using pins P3_3 to P3_8.
EMC 8-bit	0	0	1	1	Boot from external static memory (such as NOR flash) using CS0 and an 8-bit data bus.
EMC 16-bit	0	1	0	0	Boot from external static memory (such as NOR flash) using CS0 and a 16-bit data bus.
EMC 32-bit	0	1	0	1	Boot from external static memory (such as NOR flash) using CS0 and a 32-bit data bus.
USB0	0	1	1	0	Boot from USB0.
USB1	0	1	1	1	Boot from USB1.
SPI (SSP)	1	0	0	0	Boot from SPI flash connected to the SSP0 interface on P3_3 (function SSP0_SCK), P3_6 (function SSP0_SSEL), P3_7 (function SSP0_MISO), and P3_8 (function SSP0_MOSI) ^[1] .
USART3	1	0	0	1	Boot from device connected to USART3 using pins P2_3 and P2_4. For flash parts, enter UART ISP mode. The secure boot from USART3 is not supported for LPC18Sxx parts.

[1] The boot loader programs the appropriate pin function at reset to boot using SSP0.

Remark: Pin functions for SPIFI and SSP0 boot are different.

Table 16. Boot mode when OTP BOOT_SRC bits are zero

Boot mode	P2_9	P2_8	P1_2	P1_1	Description
USART0	LOW	LOW	LOW	LOW	Boot from device connected to USART0 using pins P2_0 and P2_1. For flash parts, enter UART ISP mode.
SPIFI	LOW	LOW	LOW	HIGH	Boot from Quad SPI flash connected to the SPIFI interface on P3_3 to P3_8 ^[1] .
EMC 8-bit	LOW	LOW	HIGH	LOW	Boot from external static memory (such as NOR flash) using CS0 and an 8-bit data bus.
EMC 16-bit	LOW	LOW	HIGH	HIGH	Boot from external static memory (such as NOR flash) using CS0 and a 16-bit data bus.
EMC 32-bit	LOW	HIGH	LOW	LOW	Boot from external static memory (such as NOR flash) using CS0 and a 32-bit data bus.
USB0	LOW	HIGH	LOW	HIGH	Boot from USB0.
USB1	LOW	HIGH	HIGH	LOW	Boot from USB1.
SPI (SSP)	LOW	HIGH	HIGH	HIGH	Boot from SPI flash connected to the SSP0 interface on P3_3 (function SSP0_SCK), P3_6 (function SSP0_SSEL), P3_7 (function SSP0_MISO), and P3_8 (function SSP0_MOSI) ^[1] .
USART3	HIGH	LOW	LOW	LOW	Boot from device connected to USART3 using pins P2_3 and P2_4. For flash parts, enter UART ISP mode. The secure boot from USART3 is not supported for LPC18Sxx parts.

[1] The boot loader programs the appropriate pin function at reset to boot using SSP0 or SPIFI.

Remark: Pin functions for SPIFI and SSP0 boot are different.

4.3.1 Boot process for parts with internal flash

If pin P2_7 is sampled LOW, the boot loader checks the OTP bits and/or the external boot pins to determine the communication port. If the OTP bits and boot pins are set to USART0 or USART3, the part enters UART ISP mode.

A boot image must have a valid signature to be a valid flash image (see [Section 5.4.4.1](#)), and on parts with dual flash banks, only one flash bank should contain a valid image. You can use the ISP/IAP command Set active boot flash bank to configure one flash bank with the valid image (see [Section 5.8.12](#) and [Section 5.8.12](#)). If both images are valid, the boot loader loads the image located in flash bank A.

Remark: If the boot loader image is located in flash bank B and data is stored in flash bank A, then ensure that the data in flash bank A does not appear to be a valid image. An example of a data set that would be interpreted as a valid image is a set in which the first eight words of flash bank A contain all zeros.

This implies that the data in the first 8 locations of sector 0 in flash bank A cannot be chosen freely. For example, choose data in location 8 in such a way that a non-valid image is created. See [Section 5.4.4.1](#).

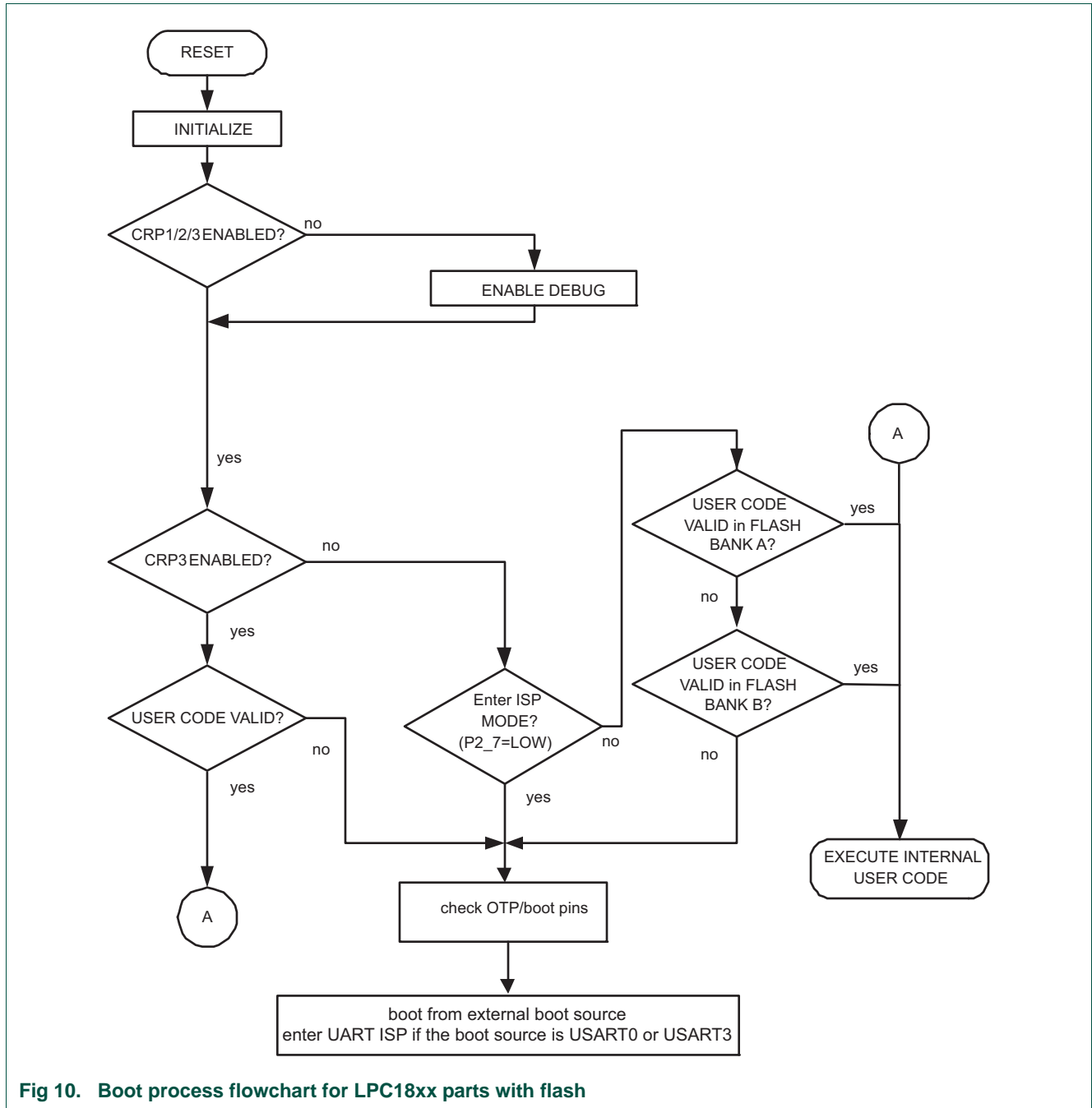

Fig 10. Boot process flowchart for LPC18xx parts with flash

4.3.2 Boot process for parts without flash

Remark: See [Chapter 5](#) for the boot process on parts with on-chip flash.

The top level boot process is illustrated in [Figure 11](#). The boot starts after Reset is released. The IRC is selected as CPU clock and the Cortex-M3 starts the boot loader. When the part is non-AES capable or it is AES capable but the AES key1 has not been programmed then JTAG access is enabled. If AES key1 has been programmed, JTAG is disabled.

As shown in [Figure 11](#), the boot ROM determines the boot mode based on the OTP BOOT_SRC value or reset state of the pins P1_1, P1_2, P2_8, and P2_9. The boot ROM copies the image to internal SRAM at location 0x1000 0000 and jumps to that location (sets ARM's shadow pointer to 0x1000 0000) after image verification. Hence the images for LPC18xx should be compiled with entry point at 0x0000 0000. On AES capable LPC18xx with a programmed AES key, the image and header are authenticated using the CMAC algorithm. If authentication fails the device is reset.

On AES capable parts with AES key1 not programmed and non-AES capable parts, the image and header are not authenticated. If the image is not preceded by a header then the image is not copied to SRAM but assumed to be executable as-is. In that case the shadow pointer is set to the first address location of the external boot memory. The header-less images should be compiled with entry point at 0x0000 0000, the same as for an image with header.

Remark: When the boot process fails, pin P1_1 toggles at a 1 Hz rate for 60 seconds. After 60 seconds, the device is reset.

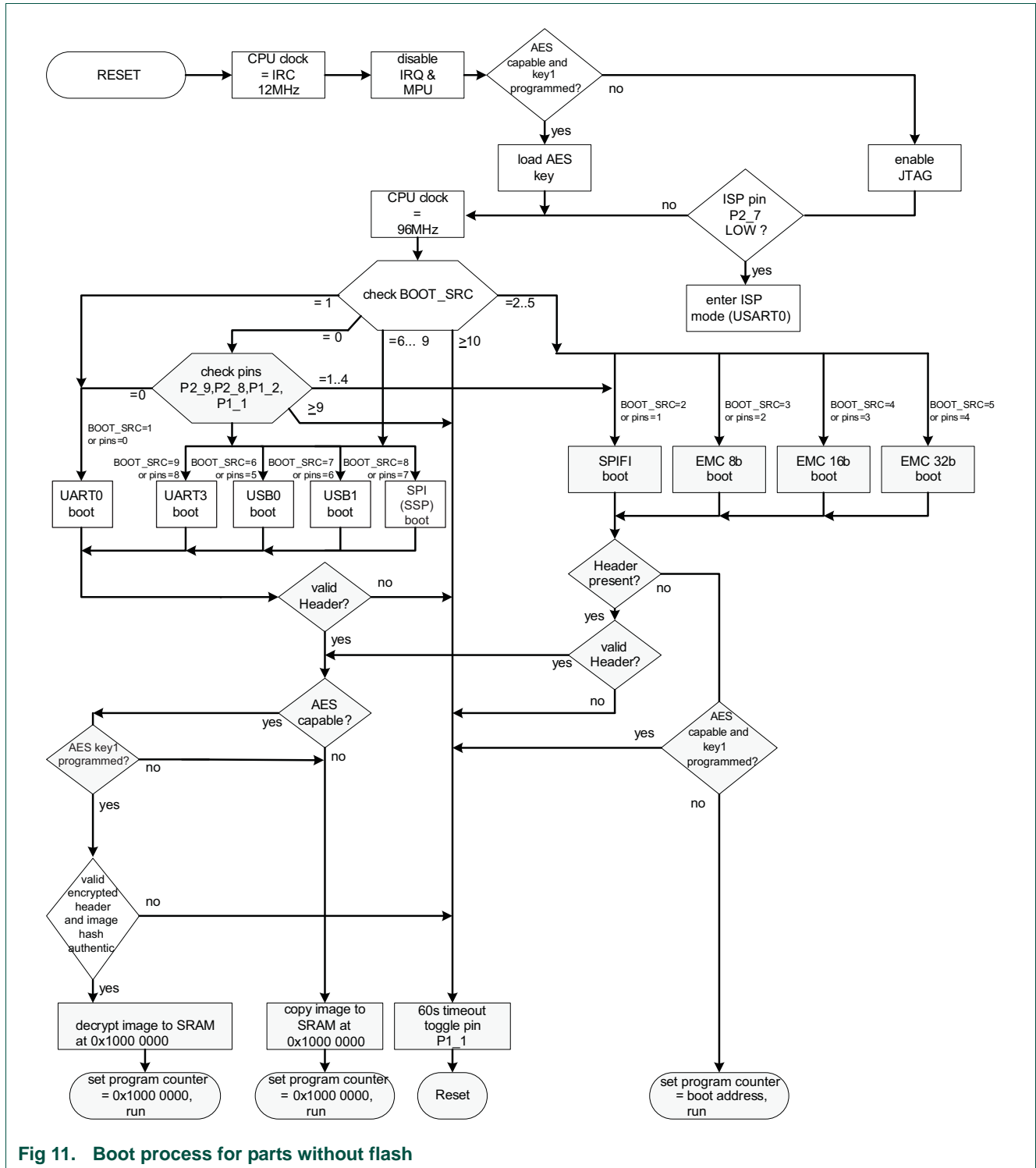

Fig 11. Boot process for parts without flash

4.3.3 AES capable parts

AES capable parts will normally always boot from a secure (encrypted) image and use CMAC authentication. However a special development mode allows booting from a plain text image. This development mode is active when the AES key1 has not been programmed.

Remark: Once the AES key1 is programmed in the OTP, the development mode is terminated and JTAG access is disabled. [Table 67 “AES API calls”](#) includes the API call for programming the AES key1.

4.3.4 Boot image header format

AES capable products with a programmed AES key1 will always boot from a secure image and use CMAC authentication. A secure image should always include a header.

Non-AES capable products may boot from an image with header or execute directly from the boot source if the boot source is memory mapped (see [Table 17](#)). When no valid header is found then the CPU will try to execute code from the first location of the memory mapped boot source. The user should take care that this location contains executable code, otherwise a hard fault exception will occur. This exception jumps to a while(1) loop.

Table 17. Boot image header use

Boot source	Memory mapped	Header required
USART0	no	yes
SPIFI	yes	no
EMC 8-bit	yes	no
EMC 16-bit	yes	no
EMC 32-bit	yes	no
USB0	no	yes
USB1	no	yes
SPI (SSP)	no	yes
USART3	no	yes

The image must be preceded by a header that has the layout described in [Table 18](#). For encrypted images the header must be encrypted with the AES user key 1 and initialization vector iv = 0. The user key is stored in the OTP (see [Table 9](#)). Non-encrypted images may omit the header.

Table 18. Boot image header description

Address	Name	Description	size [bits]
5:0	AES_ACTIVE ^[1]	AES encryption active 0x25 (100101): AES encryption active 0x1A (011010): AES encryption not active all other values: invalid image	6
7:6	HASH_ACTIVE ^[1]	Indicates whether a hash is used: 00: CMAC hash is used, value is HASH_VALUE 01: reserved 10: reserved 11: no hash is used	2
15:8	AES_CONTROL	These 2 bits can be set to a value such that when AES encryption is active, that the AES_ACTIVE field, after AES encryption, is not equal to the value 0x1A (AES encryption not active)	2
31:16	HASH_SIZE ^[3]	Size of the part of the image over which the hash value is calculated in number of 512 Byte frames. Also size of image copied to internal SRAM at boot time. Hash size = 16 ^[2] + HASH_SIZE x 512 Byte.	16
95:32	HASH_VALUE	CMAC hash value calculated over the first bytes of the image (starting right from the header) as indicated by HASH_SIZE. The value is truncated to the 64 MSB.	64
127:96	RESERVED	11...11 (binary)	32

[1] Can only be active if device is AES capable, else is considered an invalid image.

[2] 16 extra bytes are required for the header bytes.

[3] The image size should be set to no more than the size of the SRAM located at 0x1000 0000.

4.3.5 Boot image creation

4.3.5.1 CMAC

The CMAC algorithm is used to calculate a tag which is used for image authentication. The tag is stored in the header field HASH_VALUE.

The authentication process works as follows:

1. Use the CMAC algorithm to generate the 128-bit tag. Truncate the tag to 64 MSB and insert this truncated tag in the header.
2. At boot time the tag is recalculated. Authentication passes when the calculated tag is equal to the received tag in the image header.

To generate an I-bit CMAC tag T of message M using a 128-bit block cipher AES and secret key K, the CMAC tag generation process works as follows:

1. Generate sub key K_1 :
 - Calculate a temporary value $K_0 = \text{AES}_K(0)$.

- If $\text{msb}(K_0) = 0$ then $K_1 = (K_0 \ll 1)$ else $K_1 = (K_0 \ll 1) \oplus 0x87$
- 2. Divide message into 128-bit blocks $M = M_1 \parallel \dots \parallel M_{n-1} \parallel M_n^*$, where $M_1 \dots M_{n-1}$ are complete blocks.
- 3. The last block, M_n^* , should be padded to be a complete block and then $M_n = K_1 \oplus M_n^*$.
- 4. Let $c_0 = 00\dots0$.
- 5. For $i = 1, \dots, n$, calculate $c_i = \text{AES}_K(c_{i-1} \oplus M_i)$.
- 6. Output $T = \text{msb}_l(c_n)$.

The first message block is the header. Since the CMAC tag is stored in the header field HASH_VALUE, and this tag is not yet known until after CMAC calculation, a temporary header with a dummy tag value of 0x3456789A is used during CMAC calculation. This dummy value should be replaced by the calculated tag value in the final header field HASH_VALUE.

For LPC18xx the chosen CMAC parameters are: encryption key $K = \text{User Key}$ (AES key1, same as used for decryption) and tag length $l = 64$. Data is processed in little endian mode. This means that the first byte read from the image is integrated into the AES codeword as least significant byte. The 16th byte read from the image is the most significant byte of the first AES codeword.

CMAC is calculated over the header and encrypted image.

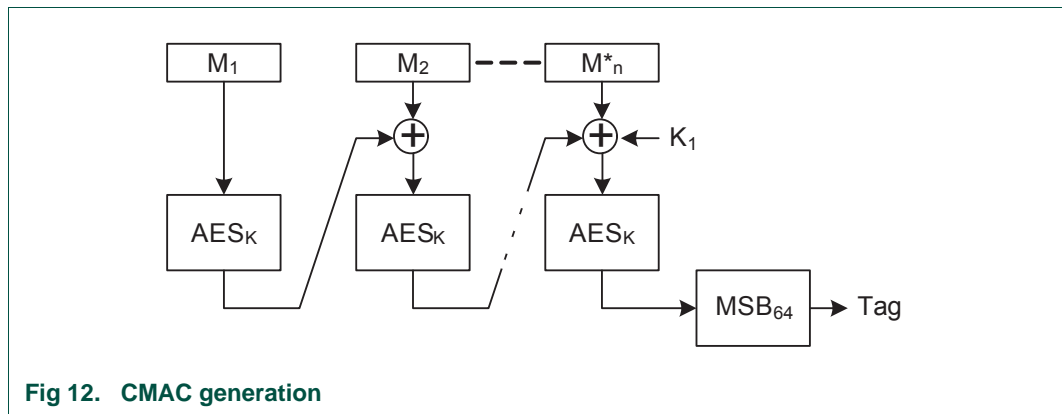

Fig 12. CMAC generation

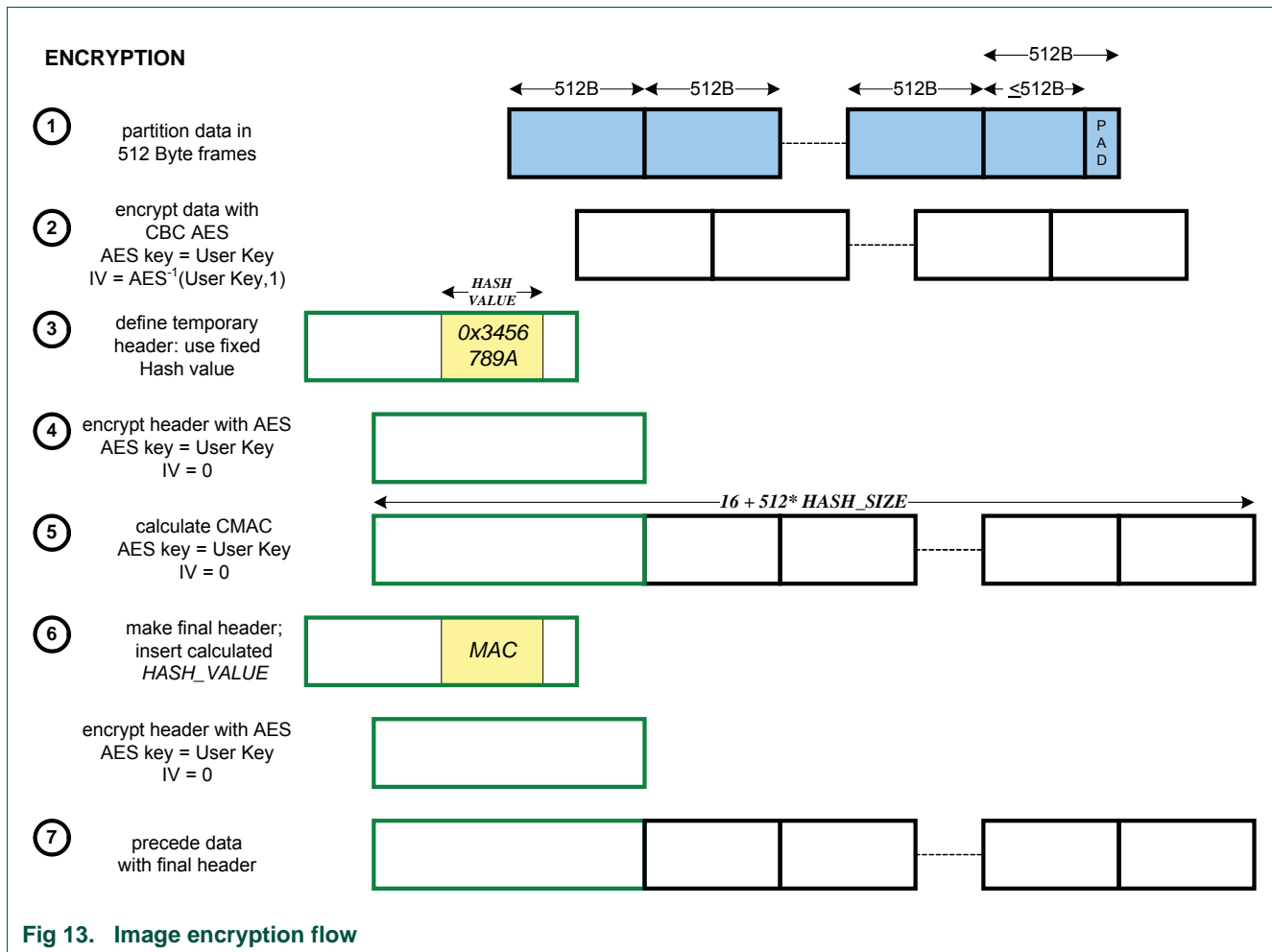

Fig 13. Image encryption flow

4.3.6 Boot modes

4.3.6.1 UART boot mode

[Figure 14](#) details the boot-flow steps of the UART boot mode. The execution of this mode occurs only if the boot mode is set accordingly (see boot modes [Table 15](#) and [Table 16](#)).

As illustrated in [Figure 14](#), configure the UART with the following settings:

- Baudrate = 115200, 57600, 38400, 19200, or 9600
- Data bits = 8
- Parity = None
- Stop bits = 1

Auto baud is active; boot waits until 0x3F is received and responds with “OK”. This should be followed by the header and image. The boot ROM doesn’t implement any flow control or any handshake mechanisms during file transfer.

After the boot image is downloaded, it is checked (based on header information) to be a valid or invalid image and OK respectively FAILED is sent to a host followed by CR and LF. Finally, the full boot image is copied, processed to address 0x10000000 and executed from there.

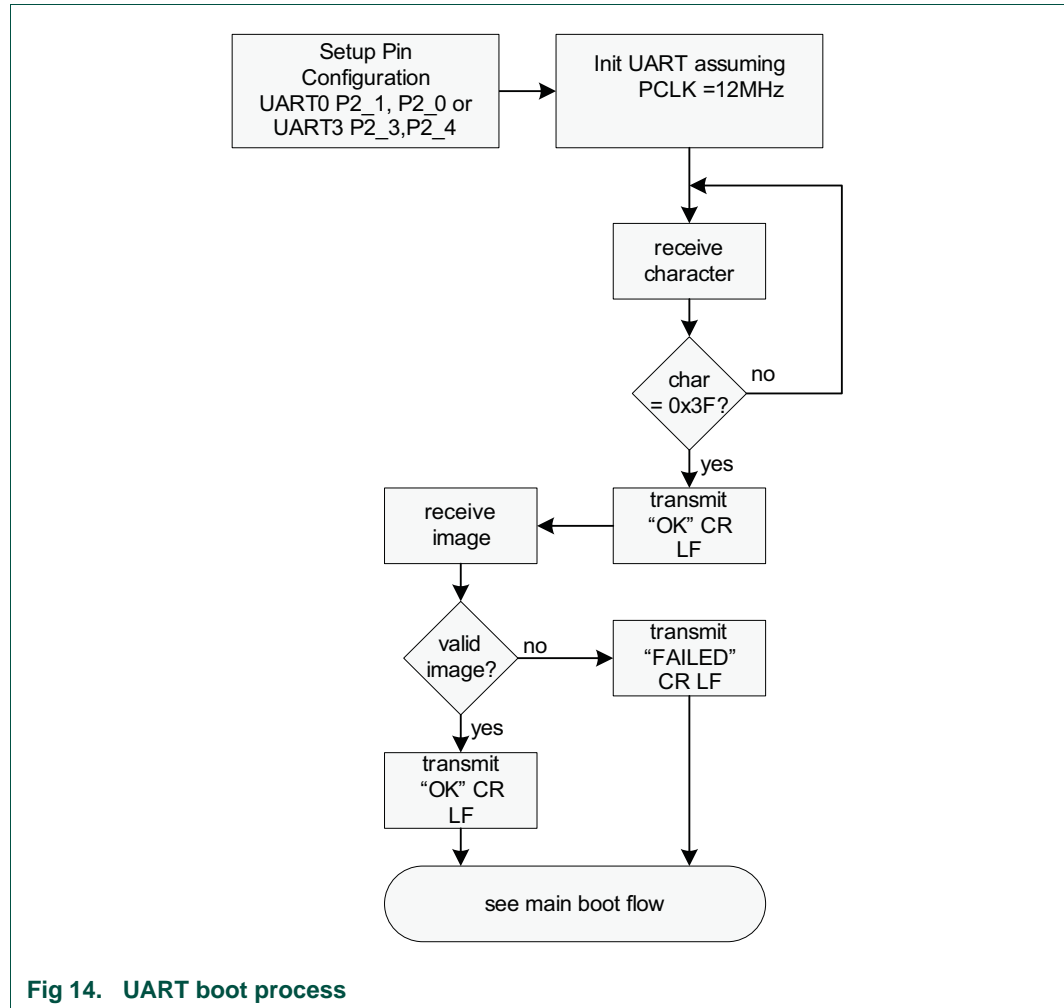

4.3.6.2 EMC boot mode

The EMC boot process follows the main flow shown in [Figure 15](#). The CPU clock is set to 96 MHz, and a non-AES capable part will boot directly from EMC when the image does not contain a header. EMC uses 0xE (wait states providing approximately 156 ns delay before capturing data (see [Section 4.1](#)).

Note that the number of address bits selected in pin configuration is initially EMC_A[13:0]. All higher address bit pins are configured as pull down but not actively driven. After reading the header, the address bits are extended to be in line with the image size as defined by HASH_SIZE, e.g. if HASH_SIZE is 100 kB then pins EMC_A[16:14] are configured since 2¹⁷ > 100 kB. When booting without header, then the image should configure extra address pins if more are needed beyond the initially configured EMC_A[13:0]. This configuration should happen in the initial 16 kB area of the image.

If no header is present it is assumed that the image is located on address 0x1C000000 and is executed from there.

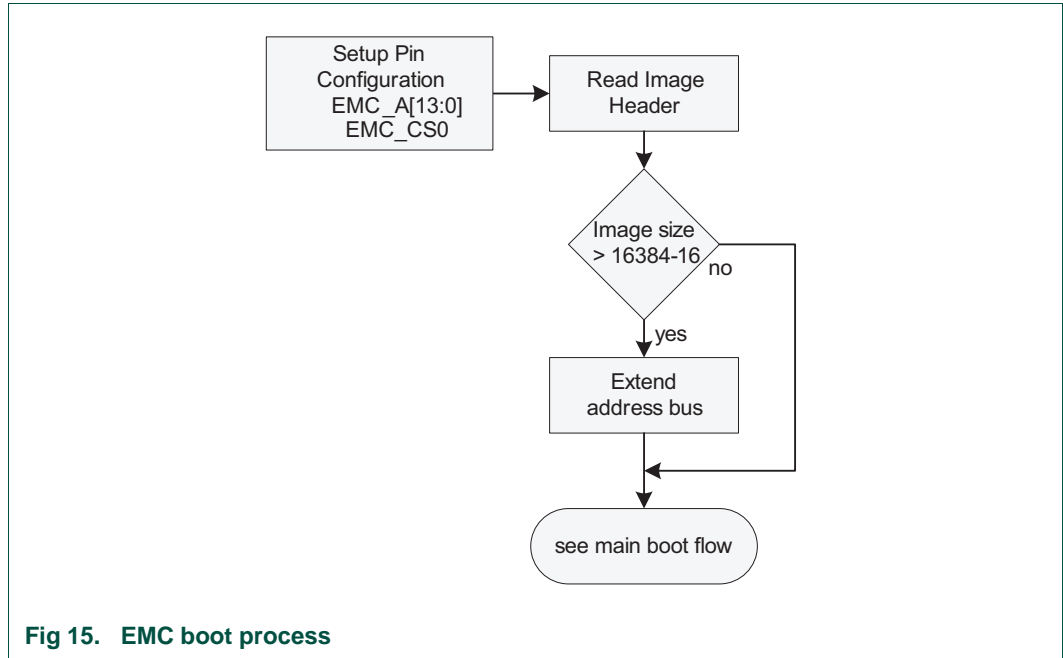

Fig 15. EMC boot process

4.3.6.3 SPI boot mode

The boot uses SSP0 in SPI mode. The SPI clock is 18 MHz.

Figure 16 details the boot-flow steps of the SPI flash boot mode. The execution of this mode occurs only if the boot mode is set accordingly (see boot modes Table 15 and Table 16).

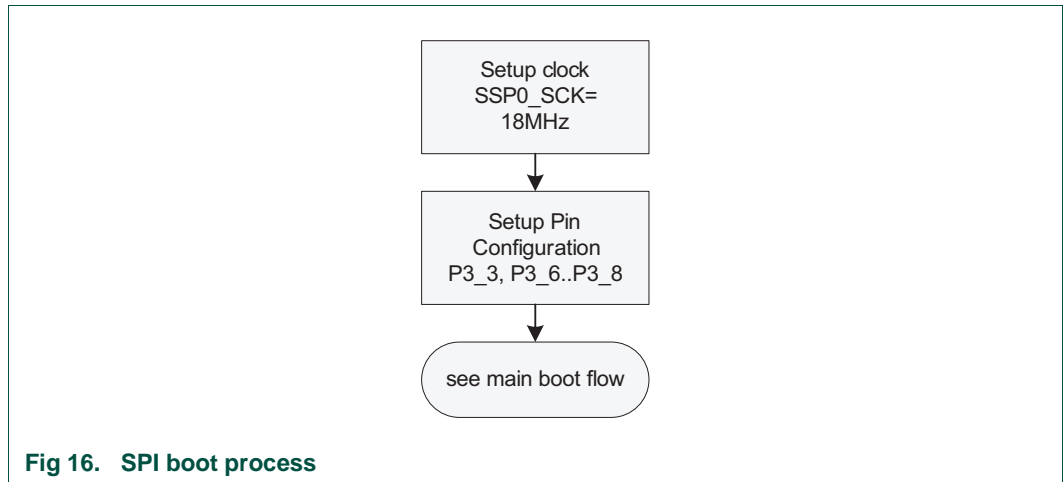

Fig 16. SPI boot process

4.3.6.4 SPIFI boot mode

Figure 17 details the boot-flow steps of the SPIFI boot mode. The execution of this mode occurs only if the boot mode is set accordingly (see boot modes in Table 15 and Table 16). The boot code sets the SPIFI clock to 18 MHz at the beginning of the boot process and

checks for the type of SPI flash device. For an SPI flash, the part boots with a 18 MHz clock. For a quad SPI flash device, the part boots with a 32 MHz clock. If the detected device is unknown, the SPIFI clock is reduced to 18 MHz.

If no header is present, it is assumed that the image is located on address 0x80000000 and is executed from there.

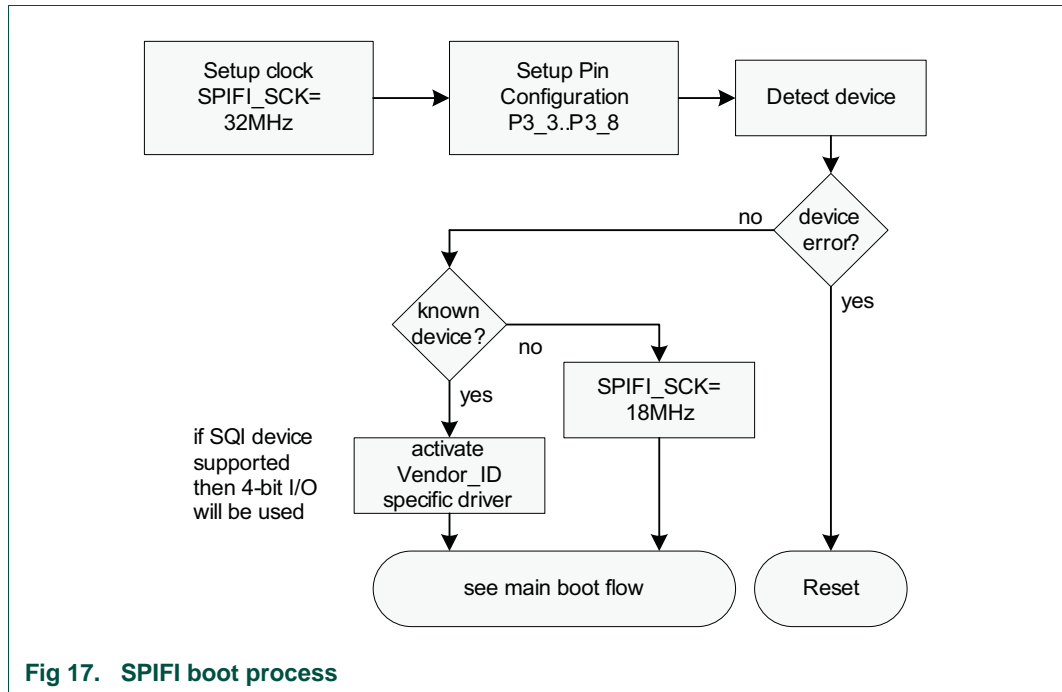

4.3.6.4.1 Supported QSPI devices

Multiple QSPI devices from various vendors can be used with the SPIFI interface and the SPIFI API available on nxp.com.

LPC18xx devices support boot from flash. The boot code sets the SPIFI clock to 32 MHz at the beginning of the boot process and checks for the type of SPI flash device. If the detected device is not recognized by LPC18xx, the SPIFI clock is reduced to 18 MHz.

The devices listed in [Table 19](#) are tested to work as boot devices for the LPC18xx and with the SPIFI API.

Remark: All QSPI devices have been tested at an operating voltage of 3.3 V.

Table 19. QSPI devices supported by the boot code and the SPIFI API

Manufacturer	Device	Exit from no opcode mode	Comment
Chingis	PM25LD040, PM25LD010C, PM25LD020C, PM25LD512C, PM25LD256C, PM25LQ032C	Yes	-
Giga Device	GD25Q80	Yes	-
Macronix	MX25L6435E, MX25L8006E, MX25L1606E, MX25L8035E, MX25L1633E, MX25L3235E, MX25L6435E, MX25L12835E, MX25L25635E, MX1635E	Yes	-
	MX25L12835F, MX25L25635F	Yes	These devices take longer time to be ready after power on. You may need to delay the startup of LPC18xx. One way to achieve this sequence is to delay RESETN signal of LPC18xx.
Micron	M25PX80, M25PX16, M25PX32, M25PX64, M25P10, M25P16, M25P32, M25P64, M25P80	Yes	-
	N25Q032A, N25Q064A, N25Q128A, N25Q256A	No	LPC18xx support cold boot with these devices. May not boot when LPC18xx is reset and serial flash is in no Opcode mode. In case of planned reset, MCU can get serial flash out of No Opcode mode before resetting itself.
Spansion	S25FL032P, S25FL064P, S25FL128S, S25FL256S, S25FL256S, S25FL129P, S25FL004K, S25FL008K S25FL016K, S25FL032K, S25FL064K, S25FL116K, S25FL132K, S25FL164K, S25FL127S	Yes	-
SST (Microchip)	SST25VF064, SST25VF016	Yes	-
Winbond	W25Q80BV, W25Q16DV, W25Q32FV, W25Q64FV, W25Q128FV, W25Q256FV, W25Q32JVSIQ, W25Q64JVSIQ	Yes	-

Remark: In addition, you might enable a QSPI device to boot by adding external circuitry to delay the LPC18xx reset signal and provide extra time for the QSPI device to come up. To boot from serial flashes, it is recommended that customers fully characterize the timing in their applications.

Devices that comply with the following guidelines are expected to support the boot code:

- Any device that can accept a 03 read serial opcode after receiving an FF opcode is expected to boot successfully.
- A device that switches to quad opcodes and doesn't return after an 0xff reset to serial mode might not boot after a reset.

Remark: After booting, include the SPIFI API driver in your firmware image and use it to re-initialize the SPIFI device for best performance.

4.3.6.5 USB boot mode

For booting from USB, two USB interfaces are available. USB0 supports high-speed and full-speed while USB1 supports only full-speed. This boot mode requires that a 12 MHz external crystal is connected to the XTAL1/2 pins. The boot code configures the CGU accordingly. The USB clock is respectively set to 480 MHz or 60 MHz. USB1 requires the VBUS pin to be set correctly.

Initially, the USB0 PHY is disabled to save some power. After it is enabled, enumeration can start. The DFU class is used to download a boot image. After receiving a boot image from a host, the image is validated based on a set of rules mentioned earlier. If valid, the image is processed accordingly to address 0x1000 0000 and executed from there.

USB product and vendor ID are defined by the OTP memory (see [Table 10](#) and [Table 11](#)).

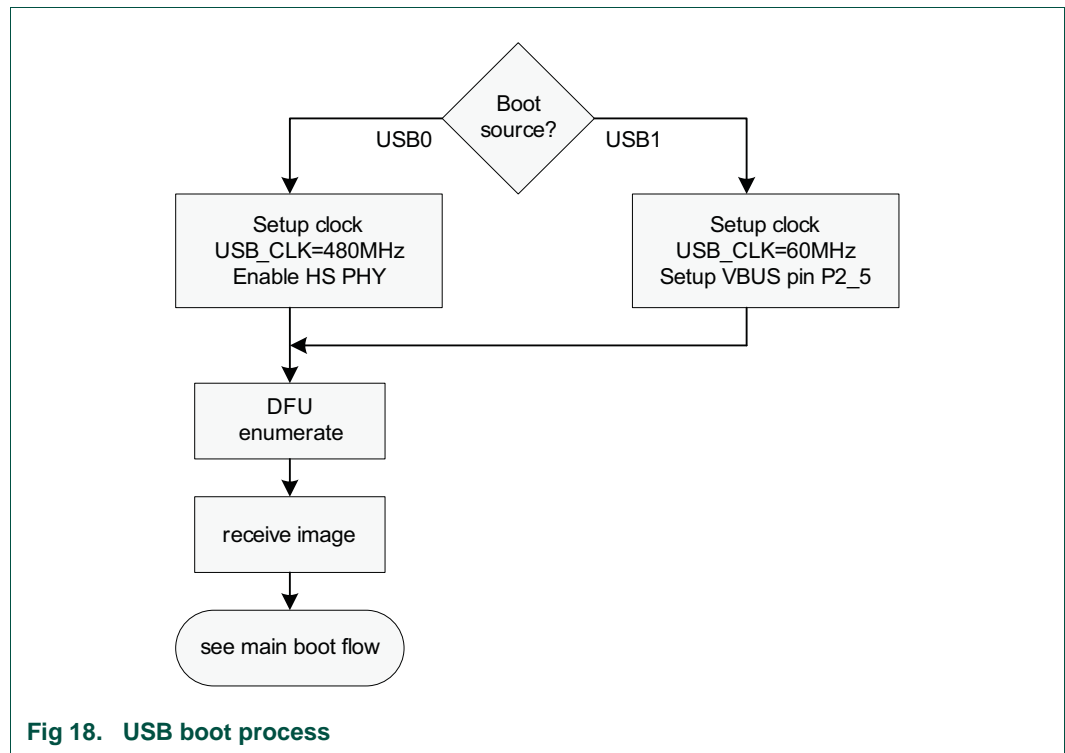

Fig 18. USB boot process

4.3.7 Boot process timing

The following parameters describe the timing of the boot process:

Table 20. Typical boot process timing parameters

Parameter	Description	Value
t_a	Check boot selection pins	< 1.25 μs
t_b	Initialize device	250 μs ^[1] ; 180 μs ^[2] ; 200 μs ^[3]
t_c	Copy image to embedded SRAM	< 0.3 μs
	If part is executing from external flash with no copy	
	If the image is encrypted or must be copied	< 1 μs to 10000 μs depending on the size of the image and the speed of the boot memory

- [1] For flashless parts LPC1850/30/20/10.
- [2] For parts with on-chip flash; booting from flash.
- [3] For parts with on-chip flash; booting from an external source.

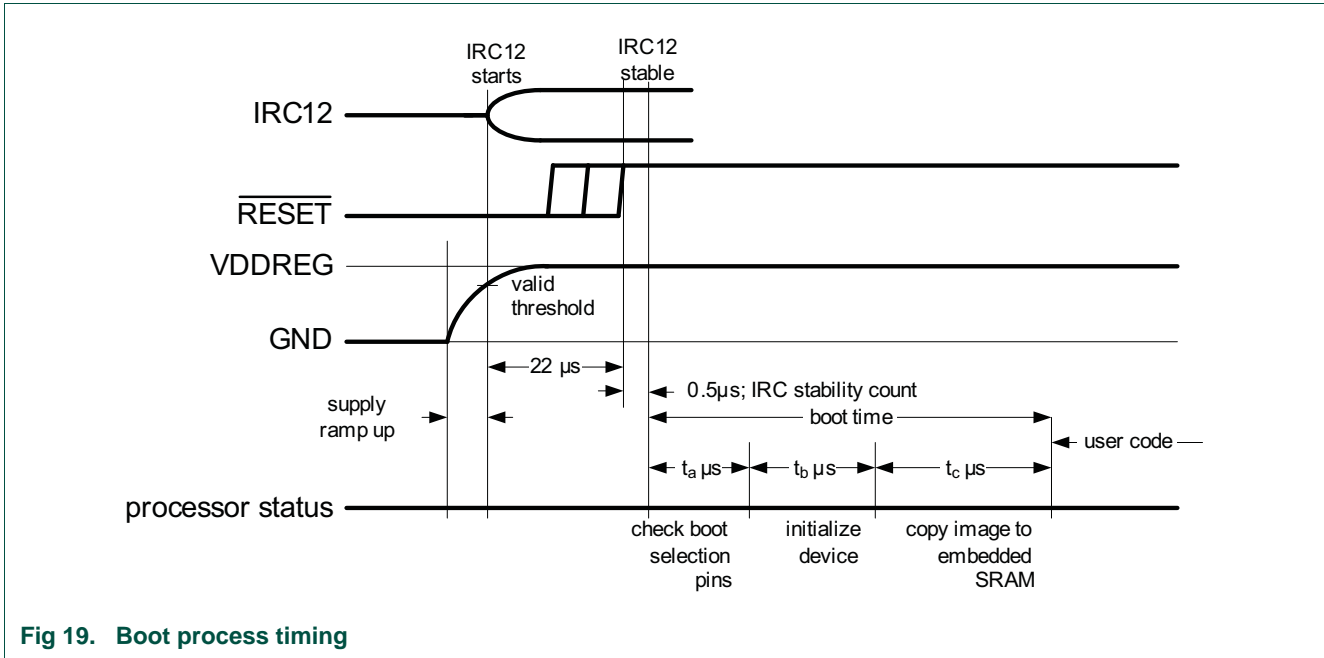

Fig 19. Boot process timing

4.3.8 UART ISP

In-System programming (ISP) is programming or re-programming the on-chip SRAM memory using the boot loader software and the USART0 serial port. For flash parts, USART3 is available for ISP communication as well (see [Table 15](#) and [Table 16](#)). ISP can be performed when the part resides in the end user board.

A LOW level on pin P2_7 after reset indicates hardware request to enter ISP mode.

ISP commands include preparing the on-chip flash for erase and write operation, reading, writing, and erasing flash, and executing code from flash. For flashless parts, a limited set of ISP commands is supported which allows to load data into on-chip SRAM and execute code from on-chip SRAM. For details, see [Chapter 5](#).

5.1 How to read this chapter

The flash programming ISP is available for parts with on-chip flash. A reduced set of In-System-Programming (ISP) commands is supported for flashless parts (see [Table 27](#)). See [Chapter 4](#) for details on the boot process for flashless parts.

IAP commands are only supported for parts with on-chip flash.

5.2 Basic configuration

- The flash banks are reset by the FLASHA_RST and FLASHB_RST (reset # 25/29).
- The flash bank interrupts are ORed with the interrupts from the EEPROM and are connected to interrupt slot #4 in the NVIC.
- The flash accelerator and the flash access time are controlled by the FLASHCFGA and FLASHCFGB registers in the CREG block (see [Table 93](#) and [Table 94](#)).
- If the application uses the IAP interface, it must reserve the SRAM space used by IAP as outlined in [Section 5.4.5.8 “RAM used by IAP command handler”](#).

The ISP is configured as follows:

- The ISP mode is entered when pin P2_7 is pulled LOW for parts with and without on-chip flash.
 - On parts with on-chip flash, ISP communication uses USART0 or USART3 depending on the OTP bits and/or boot pins (see [Section 4.3](#)).
 - On flashless parts, ISP communication always uses USART0.

Table 21. ISP clocking and power control

	Base clock	Branch clock	Operating frequency	Notes
ISP command clock CCLK	BASE_M3_CLK	CLK_M3_BUS	up to 180 MHz	-

5.3 Features

- In-System Programming: In-System programming (ISP) is programming or reprogramming the on-chip flash memory, using the boot loader software and USART0 or USART3 serial port. This can be done when the part resides in the end-user board.
- For parts without on-chip flash, ISP allows to load data to on-chip SRAM and to execute code from on-chip SRAM using USART0.
- In Application Programming: In-Application (IAP) programming is performing erase and write operation on the on-chip flash memory, as directed by the end-user application code.
- Flash signature generation: built-in hardware can generate a signature for a range of flash addresses or for the entire flash memory.

5.4 General description

The boot loader controls initial operation after reset and also provides the tools for programming the flash memory. This could be initial programming of a blank device, erasure and re-programming of a previously programmed device, or programming of the flash memory by the application program in a running system.

Remark: The initial value of the flash memory and the memory value after an erase operation is all 1s.

The boot loader code is executed every time the part is powered on or reset. The boot loader can execute the ISP command handler or the user application code.

A HIGH level after reset on pin P2_7, starts the boot process either from on-chip flash if available or from an external boot source for flashless parts depending on the configuration of the OTP memory or the boot pins (see [Chapter 4](#)).

A LOW level after reset on pin P2_7 indicates an external hardware request to start the ISP command handler:

- On parts with on-chip flash, the setting of the OTP bits and the boot pins determine which USART (USART0 or USART3) is configured for ISP communication (see [Section 4.3](#)).
- On flashless parts, ISP communication uses USART0 regardless of the settings of the OTP bits or the boot pins.

When ISP mode is entered after a power-on-reset, the IRC and PLL1 are used to generate the M3 core clock of 96 MHz. Pins P2_0 and P2_1 are used for communication with the USART0 and pins P2_3 and P2_4 are used for USART3. The UART PCLK (from BASE_UART0/3_CLK) is set to the IRC (12 MHz).

After determining the host's baud rate, the test string "Synchronized" is sent to a host. After a successful handshake, ISP enters the command interpret mode.

Table 22. ISP functionality for flash parts

ISP pin P2_7	Flash image	Action
HIGH	Valid flash image	Boot from flash.
HIGH	Invalid flash image	Check OTP for ISP source pins (USART0 or USART3) If OTP BOOT_SRC = 0x0, check boot pins. See Section 4.3 .
LOW	-	Check OTP for ISP mode or external boot. If OTP BOOT_SRC = 0x0 and boot pins are all LOW, enter ISP mode via USART0. See Section 4.3 .

Table 23. ISP functionality for flash-less parts

ISP pin P2_7	Action
HIGH	Boot from external source as indicated by OTP or boot pins. See Section 4.3 .
LOW	Enter ISP mode using USART0, pins P2_0 and P2_1

5.4.1 Sampling of pin P2_7

Assuming that power supply pins are on their nominal levels when the rising edge on RESET pin is generated, it may take up to 3 ms before P2_7 is sampled and the decision on whether to continue with user code or ISP handler is made.

If a valid user program is found, then the execution control is transferred to it. If a valid user program is not found, the boot process defaults to the ISP mode using USART0 and the auto-baud routine is invoked.

Pin P2_7 is used as a hardware request signal for ISP and requires special attention. It is recommended to provide external hardware (a pull-up resistor or other device) to put the pin in a defined state. Otherwise unintended entry into ISP mode may occur.

5.4.2 Boot process for flashless parts

See [Figure 11](#) for the boot process flowchart for flashless parts. If P2_7 is HIGH, the boot code samples the OTP and the boot pins to determine the boot source. If P2_7 is LOW, the boot code configures USART0 for ISP communication.

5.4.3 Boot process for parts with internal flash

If pin P2_7 is sampled LOW, the boot loader checks the OTP bits and/or the external boot pins to determine the communication port. If the OTP bits and boot pins are set to USART0 or USART3, the part enters UART ISP mode.

See [Section 4.3.1 “Boot process for parts with internal flash”](#) for details.

5.4.4 Memory map after any reset

When a user program begins execution after reset, the interrupt vectors are set to point to the beginning of flash memory (see [Figure 5](#)).

5.4.4.1 Criterion for Valid User Code

The reserved Cortex-M3 exception vector location 7 (offset 0x 001C in the vector table) should contain the 2's complement of the check-sum of table entries 0 through 6. This causes the checksum of the first 8 table entries to be 0. The boot loader code checksums the first 8 locations in sector 0 of the flash. If the result is 0, then execution control is transferred to the user code.

If the signature is not valid, the auto-baud routine synchronizes with the host via serial port 0. The host should send a “?” (0x3F) as a synchronization character and wait for a response. The host side serial port settings should be 8 data bits, 1 stop bit and no parity. The auto-baud routine measures the bit time of the received synchronization character in terms of its own frequency and programs the baud rate generator of the serial port. It also sends an ASCII string ("Synchronized<CR><LF>") to the host. In response to this the host should send the same string ("Synchronized<CR><LF>"). The auto-baud routine looks at the received characters to verify synchronization. If synchronization is verified then "OK<CR><LF>" string is sent to the host. The host should respond by sending "0<CR><LF>" for backwards compatibility with existing tools. "OK<CR><LF>" string is sent to the host after receiving "0<CR><LF>". If synchronization is not verified then the auto-baud routine waits again for a synchronization character.

Once the UART has established synchronization, the boot loader invokes the ISP command handler. For safety reasons an "Unlock" command is required before executing the commands resulting in flash erase/write operations and the "Go" command. The rest of the commands can be executed without the unlock command. The Unlock command is required to be executed once per ISP session. The Unlock command is explained in [Section 5.7 “ISP commands” on page 65](#).

5.4.5 Communication protocol

All ISP commands should be sent as single ASCII strings. Strings should be terminated with Carriage Return (CR) and/or Line Feed (LF) control characters. Extra <CR> and <LF> characters are ignored. All ISP responses are sent as <CR><LF> terminated ASCII strings. Data is sent and received in UU-encoded format.

5.4.5.1 ISP command format

"Command Parameter_0 Parameter_1 ... Parameter_n<CR><LF>" "Data" (Data only for Write commands).

5.4.5.2 ISP response format

"Return_Code<CR><LF>Response_0<CR><LF>Response_1<CR><LF> ...
Response_n<CR><LF>" "Data" (Data only for Read commands).

5.4.5.3 ISP data format

The data stream is in UU-encoded format. The UU-encode algorithm converts 3 B of binary data in to 4 B of printable ASCII character set. It is more efficient than Hex format which converts 1 byte of binary data in to 2 bytes of ASCII hex. The sender should send the check-sum after transmitting 20 UU-encoded lines. The length of any UU-encoded line should not exceed 61 characters (bytes) i.e. it can hold 45 data bytes. The receiver should compare it with the check-sum of the received bytes. If the check-sum matches then the receiver should respond with "OK<CR><LF>" to continue further transmission. If the check-sum does not match the receiver should respond with "RESEND<CR><LF>". In response the sender should retransmit the bytes.

5.4.5.4 ISP flow control

A software XON/XOFF flow control scheme is used to prevent data loss due to buffer overrun. When the data arrives rapidly, the ASCII control character DC3 (0x13) is sent to stop the flow of data. Data flow is resumed by sending the ASCII control character DC1 (0x11). The host should also support the same flow control scheme.

5.4.5.5 ISP command abort

Commands can be aborted by sending the ASCII control character "ESC" (0x1B). This feature is not documented as a command under "ISP Commands" section. Once the escape code is received the ISP command handler waits for a new command.

5.4.5.6 Interrupts during IAP

The on-chip flash memory is not accessible during erase/write operations. When the user application code starts executing the interrupt vectors from the user flash area are active. The user should either disable interrupts or ensure that user interrupt vectors are active in RAM and that the interrupt handlers reside in RAM, before making a flash erase/write IAP call. The IAP code does not use or disable interrupts.

5.4.5.7 RAM used by ISP

The boot code uses the local SRAM block at address 0x10080000 as its working area. In parts with on-chip flash the content of the whole 40 kB SRAM block may be lost upon reset. In parts without on-chip flash the lower 32 kB of this SRAM block may be lost upon reset.

5.4.5.8 RAM used by IAP command handler

Flash programming commands use 16 B of RAM from 0x10089FF0 to 0x10089FFF. Applications making use of IAP calls must reserve this RAM block. The maximum stack usage in the user allocated stack space is 256 B. The stack space is excluding usage of IAP Set active partition command. The Set active partition command requires an additional 2200 B in stack additionally for a maximum of 2456 B.

5.4.6 Flash signature generation

For parts with on-chip flash, a hardware flash signature generation capability is built into the flash memory. This feature can be used to create a signature that can then be used to verify flash contents. Details of flash signature generation are shown in [Section 5.11](#).

5.5 Sector numbers

Some IAP and ISP commands operate on sectors and specify sector numbers. The following table indicates the correspondence between sector numbers and memory addresses for LPC18xx device. IAP and ISP routines are located in the Boot ROM.

In addition, individual pages can be erased using the IAP erase page call (see [Table 55](#)). The page size is 512 B. One page is the smallest amount of data that can be written into the flash memory (see [Table 34](#)).

Table 24. Flash configuration

Flash bank	Sector number	Sector size [kB]	Start address	End address	LPC18x2	LPC18x3	LPC18x5	LPC18x7
A	0	8	0x1A00 0000	0x1A00 1FFF	yes	yes	yes	yes
A	1	8	0x1A00 2000	0x1A00 3FFF	yes	yes	yes	yes
A	2	8	0x1A00 4000	0x1A00 5FFF	yes	yes	yes	yes
A	3	8	0x1A00 6000	0x1A00 7FFF	yes	yes	yes	yes
A	4	8	0x1A00 8000	0x1A00 9FFF	yes	yes	yes	yes
A	5	8	0x1A00 A000	0x1A00 BFFF	yes	yes	yes	yes
A	6	8	0x1A00 C000	0x1A00 DFFF	yes	yes	yes	yes
A	7	8	0x1A00 E000	0x1A00 FFFF	yes	yes	yes	yes
A	8	64	0x1A01 0000	0x1A01 FFFF	yes	yes	yes	yes
A	9	64	0x1A02 0000	0x1A02 FFFF	yes	yes	yes	yes
A	10	64	0x1A03 0000	0x1A03 FFFF	yes	yes	yes	yes
A	11	64	0x1A04 0000	0x1A04 FFFF	yes	-	yes	yes
A	12	64	0x1A05 0000	0x1A05 FFFF	yes	-	yes	yes
A	13	64	0x1A06 0000	0x1A06 FFFF	yes	-	-	yes
A	14	64	0x1A07 0000	0x1A07 FFFF	yes	-	-	yes
B	0	8	0x1B00 0000	0x1B00 1FFF	-	yes	yes	yes
B	1	8	0x1B00 2000	0x1B00 3FFF	-	yes	yes	yes
B	2	8	0x1B00 4000	0x1B00 5FFF	-	yes	yes	yes
B	3	8	0x1B00 6000	0x1B00 7FFF	-	yes	yes	yes
B	4	8	0x1B00 8000	0x1B00 9FFF	-	yes	yes	yes
B	5	8	0x1B00 A000	0x1B00 BFFF	-	yes	yes	yes
B	6	8	0x1B00 C000	0x1B00 DFFF	-	yes	yes	yes
B	7	8	0x1B00 E000	0x1B00 FFFF	-	yes	yes	yes
B	8	64	0x1B01 0000	0x1B01 FFFF	-	yes	yes	yes
B	9	64	0x1B02 0000	0x1B02 FFFF	-	yes	yes	yes
B	10	64	0x1B03 0000	0x1B03 FFFF	-	yes	yes	yes
B	11	64	0x1B04 0000	0x1B04 FFFF	-	-	yes	yes
B	12	64	0x1B05 0000	0x1B05 FFFF	-	-	yes	yes
B	13	64	0x1B06 0000	0x1B06 FFFF	-	-	-	yes
B	14	64	0x1B07 0000	0x1B07 FFFF	-	-	-	yes

5.6 Code Read Protection (CRP)

Code Read Protection is a mechanism that allows user to enable different levels of security in the system so that access to the on-chip flash and use of the ISP can be restricted. When needed, CRP is invoked by programming a specific pattern in flash location at offset 0x2FC. IAP commands are not affected by the code read protection.

Important: Any CRP change becomes effective only after the device has gone through a power cycle.

Table 25. Code Read Protection options

Name	Pattern programmed at offset 0x2FC ^[1]	Description
CRP1	0x1234 5678	<p>Access to chip via the JTAG pins is disabled. This mode allows partial flash update using the following ISP commands and restrictions:</p> <ul style="list-style-type: none"> • Read Memory command: disabled. • Copy RAM to Flash command: cannot write to Sector 0. • Go command: disabled. • Erase sectors command: can erase any individual sector except sector 0 only, or can erase all sectors at once. • Compare command: disabled. This mode is useful when CRP is required and flash field updates are needed but all sectors can not be erased. The compare command is disabled, so in the case of partial flash updates the secondary loader should implement a checksum mechanism to verify the integrity of the flash. • Activate flash bank not allowed.
CRP2	0x8765 4321	<p>This is similar to CRP1 with the following additions:</p> <ul style="list-style-type: none"> • Write to RAM command: disabled. • Copy RAM to Flash: disabled. • Erase command: only allows erase of all sectors.
CRP3	0x4321 8765	<p>This is similar to CRP2, but ISP entry by pulling P2_7 LOW is disabled if a valid user code is present in flash sector 0.</p> <p>This mode effectively disables ISP override using the P2_7 pin. It is up to the user's application to provide for flash updates by using IAP calls or by invoking ISP.</p> <p>Caution: If CRP3 is selected, no future factory testing can be performed on the device.</p>
NO_ISP	0x4E69 7370	Disables ISP request using the P2_7 pin.

[1] Program the CRP pattern at address 0x1A00 02FC for flash bank A and at 0x1B00 02FC for flash bank B.

Table 26. Code Read Protection hardware/software interaction

CRP option	User Code Valid	P2_7 pin at reset	JTAG enabled	LPC18xx enters ISP mode	partial flash update in ISP mode
None	No	X	Yes	Yes	Yes
	Yes	High	Yes	No	NA
	Yes	Low	Yes	Yes	Yes
CRP1	No	x	No	Yes	Yes
	Yes	High	No	No	NA
	Yes	Low	No	Yes	Yes
CRP2	No	x	No	Yes	No
	Yes	High	No	No	NA
	Yes	Low	No	Yes	No
CRP3	No	x	No	Yes	No
	Yes	x	No	No	NA
NO_ISP	No	x	Yes	Yes	Yes
	Yes	x	Yes	No	Yes

If any CRP mode is enabled and access to the chip is allowed via the ISP, an unsupported or restricted ISP command will be terminated with return code `CODE_READ_PROTECTION_ENABLED`.

5.7 ISP commands

The following commands are accepted by the ISP command handler. Detailed status codes are supported for each command. The command handler sends the return code `INVALID_COMMAND` when an undefined command is received. Commands and return codes are in ASCII format.

`CMD_SUCCESS` is sent by ISP command handler only when received ISP command has been completely executed and the new ISP command can be given by the host. Exceptions from this rule are "Set Baud Rate", "Write to RAM", "Read Memory", and "Go" commands.

Table 27. ISP command summary

ISP Command	Usage	Flashless parts	Parts with on-chip flash	Reference
Unlock	U <Unlock Code>	yes	yes	Table 28
Set Baud Rate	B <Baud Rate> <stop bit>	yes	yes	Table 29
Echo	A <setting>	yes	yes	Table 30
Write to RAM	W <start address> <number of bytes>	yes	yes	Table 31
Read Memory	R <address> <number of bytes>	yes	yes	Table 32
Prepare sectors for write operation	P <start sector number> <end sector number> <flash bank>	no	yes	Table 33
Copy RAM to Flash	C <flash address> <RAM address> <number of bytes>	no	yes	Table 34
Go	G <address> <Mode>	yes	yes	Table 35
Erase sectors	E <start sector number> <end sector number> <flash bank>	no	yes	Table 36
Blank check sectors	I <start sector number> <end sector number> <flash bank>	no	yes	Table 37
Read Part ID	J	yes	yes	Table 38
Read Boot Code version	K	yes	yes	Table 40
Read serial number	N	yes	yes	Table 41
Compare	M <address1> <address2> <number of bytes>	no	yes	Table 42
Set active boot flash bank	S <flash bank>	no	yes	Table 43

5.7.1 Unlock <Unlock code>

Table 28. ISP Unlock command

Command	U
Input	Unlock code: 23130 ₁₀
Return Code	CMD_SUCCESS INVALID_CODE PARAM_ERROR
Description	This command is used to unlock Flash Write, Erase, and Go commands.
Example	"U 23130<CR><LF>" unlocks the Flash Write/Erase & Go commands.

5.7.2 Set Baud Rate <Baud Rate> <stop bit>

The UART PCLK is derived from the IRC at 12 MHz.

Table 29. ISP Set Baud Rate command

Command	B
Input	Baud Rate: 9600 19200 38400 57600 115200 Stop bit: 1 2
Return Code	CMD_SUCCESS INVALID_BAUD_RATE INVALID_STOP_BIT PARAM_ERROR
Description	This command is used to change the baud rate. The new baud rate is effective after the command handler sends the CMD_SUCCESS return code.
Example	"B 57600 1<CR><LF>" sets the serial port to baud rate 57600 bps and 1 stop bit.

5.7.3 Echo <setting>

Table 30. ISP Echo command

Command	A
Input	Setting: ON = 1 OFF = 0
Return Code	CMD_SUCCESS PARAM_ERROR
Description	The default setting for echo command is ON. When ON the ISP command handler sends the received serial data back to the host.
Example	"A 0<CR><LF>" turns echo off.

5.7.4 Write to RAM <start address> <number of bytes>

The host should send the data only after receiving the CMD_SUCCESS return code. The host should send the check-sum after transmitting 20 UU-encoded lines. The checksum is generated by adding raw data (before UU-encoding) bytes and is reset after transmitting 20 UU-encoded lines. The length of any UU-encoded line should not exceed 61 characters (bytes) i.e. it can hold 45 data bytes. When the data fits in less than 20 UU-encoded lines then the check-sum should be of the actual number of bytes sent. The ISP command handler compares it with the check-sum of the received bytes. If the check-sum matches, the ISP command handler responds with "OK<CR><LF>" to continue further transmission. If the check-sum does not match, the ISP command handler responds with "RESEND<CR><LF>". In response the host should retransmit the bytes.

The ISP write command can write to all internal SRAM blocks and to the external memory bank 0 (CS0 at location 0x1C00 0000). Because the ISP code uses SRAM, the Write to RAM command can not access SRAM between 0x1008 0000 and 0x1008 0200, see [Section 5.4.5.7](#).

Table 31. ISP Write to RAM command

Command	W
Input	<p>Start Address: RAM address where data bytes are to be written. This address should be a word boundary.</p> <p>Number of Bytes: Number of bytes to be written. Count should be a multiple of 4</p>
Return Code	CMD_SUCCESS ADDR_ERROR (Address not on word boundary) ADDR_NOT_MAPPED COUNT_ERROR (Byte count is not multiple of 4) PARAM_ERROR CODE_READ_PROTECTION_ENABLED
Description	This command is used to download data to RAM. Data should be in UU-encoded format. This command is blocked when code read protection levels CRP2 or CRP3 are enabled.
Example	"W 268435968 4<CR><LF>" writes 4 bytes of data to address 0x1000 0200.

5.7.5 Read Memory <address> <no. of bytes>

The data stream is followed by the command success return code. The check-sum is sent after transmitting 20 UU-encoded lines. The checksum is generated by adding raw data (before UU-encoding) bytes and is reset after transmitting 20 UU-encoded lines. The length of any UU-encoded line should not exceed 61 characters (bytes) i.e. it can hold 45 data bytes. When the data fits in less than 20 UU-encoded lines then the check-sum is of actual number of bytes sent. The host should compare it with the checksum of the received bytes. If the check-sum matches then the host should respond with "OK<CR><LF>" to continue further transmission. If the check-sum does not match then the host should respond with "RESEND<CR><LF>". In response the ISP command handler sends the data again.

The ISP read command can read from all internal SRAM blocks, from the external memory bank 0 (CS0 at location 0x1C00 0000), and from the internal flash.

Table 32. ISP Read Memory command

Command	R
Input	<p>Start Address: Address from where data bytes are to be read. This address should be a word boundary.</p> <p>Number of Bytes: Number of bytes to be read. Count should be a multiple of 4.</p>
Return Code	CMD_SUCCESS followed by <actual data (UU-encoded)> ADDR_ERROR (Address not on word boundary) ADDR_NOT_MAPPED COUNT_ERROR (Byte count is not a multiple of 4) PARAM_ERROR CODE_READ_PROTECTION_ENABLED
Description	This command is used to read data from RAM or flash memory. This command is blocked when any level of code read protection is enabled.
Example	"R 268435968 4<CR><LF>" reads 4 bytes of data from address 0x1000 0200.

5.7.6 Prepare sectors for write operation <start sector number> <end sector number> <flash bank>

This command is the first step in the two-step flash write/erase operation.

Table 33. ISP Prepare sectors for write operation command

Command	P
Input	<p>Start Sector Number</p> <p>End Sector Number: Should be greater than or equal to start sector number.</p> <p>Flash bank: Selects flash bank if the part supports more than one bank. 0 = flash bank A, 1 = flash bank B.</p>
Return Code	<p>CMD_SUCCESS </p> <p>BUSY </p> <p>INVALID_SECTOR </p> <p>PARAM_ERROR INVALID_FLASH_UNIT</p>
Description	<p>This command must be executed before executing "Copy RAM to Flash" or "Erase Sectors" command. Successful execution of the "Copy RAM to Flash" or "Erase Sectors" command causes relevant sectors to be protected again. To prepare a single sector use the same "Start" and "End" sector numbers.</p>
Example	<p>"P 0 0 0 <CR><LF>" prepares the flash sector 0 in flash bank A.</p>

5.7.7 Copy RAM to Flash <flash address> <RAM address> <no of bytes>

Before executing this command, perform the "Prepare sectors for write operation" command.

Table 34. ISP Copy command

Command	C
Input	<p>Flash Address (DST): Destination flash address where data bytes are to be written. The destination address should be a 512 byte boundary.</p> <p>RAM Address (SRC): Source RAM address from where data bytes are to be read.</p> <p>Number of Bytes: Number of bytes to be written. Should be 512 1024 4096.</p>
Return Code	<p>CMD_SUCCESS </p> <p>SRC_ADDR_ERROR (Address not on word boundary) </p> <p>DST_ADDR_ERROR (Address not on correct boundary) </p> <p>SRC_ADDR_NOT_MAPPED </p> <p>DST_ADDR_NOT_MAPPED </p> <p>COUNT_ERROR (Byte count is not 512 1024 4096) </p> <p>SECTOR_NOT_PREPARED_FOR_WRITE_OPERATION </p> <p>BUSY </p> <p>CMD_LOCKED </p> <p>PARAM_ERROR </p> <p>CODE_READ_PROTECTION_ENABLED</p>
Description	<p>This command is used to program the flash memory. The "Prepare Sectors for Write Operation" command should precede this command. The affected sectors are automatically protected again once the copy command is successfully executed. This command is blocked when code read protection levels CRP2 or CRP3 are enabled. When code read protection level CRP1 is enabled, individual sectors other than sector 0 can be written.</p>
Example	<p>"C 436207616 268468224 512 <CR><LF>" copies 512 bytes from the RAM address 0x1000 8000 to the flash address 0x1A00 0000.</p>

5.7.8 Go <address> <mode>

Table 35. ISP Go command

Command	G
Input	<p>Address: Flash or RAM address from which the code execution is to be started. This address should be on a word boundary.</p> <p>Mode (retained for backward compatibility): T (Execute program in Thumb Mode) A (not allowed).</p>
Return Code	CMD_SUCCESS ADDR_ERROR ADDR_NOT_MAPPED CMD_LOCKED PARAM_ERROR CODE_READ_PROTECTION_ENABLED
Description	This command is used to execute a program residing in RAM or flash memory. It may not be possible to return to the ISP command handler once this command is successfully executed. This command is blocked when any level of code read protection is enabled.
Example	"G 436208211 T<CR><LF>" branches to address 0x1A00 0253.

When the GO command is used, execution begins at the specified address (assuming it is an executable address) with the device left as it was configured for the ISP code. The PLL1 is configured to generate a CPU clock with a frequency of 96 MHz.

5.7.9 Erase sectors <start sector number> <end sector number> <flash bank>

Table 36. ISP Erase sector command

Command	E
Input	<p>Start Sector Number</p> <p>End Sector Number: Should be greater than or equal to start sector number.</p> <p>Flash bank: Selects flash bank if the part supports more than one bank. 0 = flash bank A, 1 = flash bank B.</p>
Return Code	CMD_SUCCESS BUSY INVALID_SECTOR SECTOR_NOT_PREPARED_FOR_WRITE_OPERATION CMD_LOCKED PARAM_ERROR CODE_READ_PROTECTION_ENABLED INVALID_FLASH_UNIT
Description	This command is used to erase one or more sectors of on-chip flash memory. This command is blocked when code read protection level CRP3 is enabled. When code read protection level CRP1 is enabled, individual sectors other than sector 0 can be erased. All sectors can be erased at once in CRP1 and CRP2.
Example	"E 2 3 0<CR><LF>" erases the flash sectors 2 and 3 in flash bank A.

5.7.10 Blank check sectors <sector number> <end sector number> <flash bank>

Table 37. ISP Blank check sector command

Command	I
Input	<p>Start Sector Number:</p> <p>End Sector Number: Should be greater than or equal to start sector number.</p> <p>Flash bank: Selects flash bank if the part supports more than one bank. 0 = flash bank A, 1 = flash bank B.</p>
Return Code	<p>CMD_SUCCESS </p> <p>SECTOR_NOT_BLANK (followed by <Offset of the first non blank word location> <Contents of non blank word location>) </p> <p>INVALID_SECTOR </p> <p>PARAM_ERROR INVALID_FLASH_UNIT</p>
Description	This command is used to blank check one or more sectors of on-chip flash memory.
Example	"I 2 3 0 <CR><LF>" blank checks the flash sectors 2 and 3 in flash bank 0.

5.7.11 Read Part Identification number

Table 38. ISP Read Part Identification command

Command	J
Input	None.
Return Code	<p>CMD_SUCCESS followed by two part identification number in ASCII (see Table 39 "LPC18xx part identification numbers").</p> <p>The command returns two words: word0 followed by word1. Only the 8 LSBs on word1 contain configuration information. The top 24 MSBs should be ignored or masked as 0s. On parts with on-chip flash, word 0 corresponds to the part id and word1 indicates the flash configuration. On flashless parts, word0 corresponds to the part id and word1 contains 0x0.</p>
Description	This command is used to read the part identification number. The part identification number maps to a feature subset within a device family. This number will not normally change as a result of technical revisions.

Remark: One device can be associated with more than one Part ID. See the errata sheet for updates on Part IDs for parts manufactured on different dates and/or with different revisions.

Table 39. LPC18xx part identification numbers

Device	Hex coding	
	Word0	Word1
LPC1850FET256	0xF000 D830	0XXXXX XX00
LPC1850FET180	0xF000 D830	0XXXXX XX00
LPC18S50FET256	0xF000 D860	0XXXXX XX00
LPC18S50FET180	0xF000 D860	0XXXXX XX00
LPC1830FET256	0xF000 DA30	0XXXXX XX00
LPC1830FET180	0xF000 DA30	0XXXXX XX00
LPC1830FET100	0xF000 DA30	0XXXXX XX00
LPC1830FBD144	0xF000 DA30	0XXXXX XX00

Table 39. LPC18xx part identification numbers

Device	Hex coding	
	Word0	Word1
LPC18S30FET256	0xF00DA60	0XXXX XX00
LPC18S30FET100	0xF00DA60	0XXXX XX00
LPC18S30FBD144	0xF00DA60	0XXXX XX00
LPC1820FET100	0xF00A DB3C	0XXXX XX00
LPC1820FBD144	0xF00A DB3C	0XXXX XX00
LPC1820FBD100	0xF00A DB3C	0XXXX XX00
LPC18S20FBD144	0xF00A DB6C	0XXXX XX00
LPC1810FET100	0xF00B 5B3F	0XXXX XX00
LPC1810FBD144	0xF00B 5B3F	0XXXX XX00
LPC18S10FET100	0xF00B 5B6F	0XXXX XX00
LPC18S10FBD144	0xF00B 5B6F	0XXXX XX00
LPC18S10FET180	0xF00B 5B6F	0XXXX XX00
LPC1857FET256	0xF001 D830	0XXXX XX00
LPC1857FET180	0xF001 D830	0XXXX XX00
LPC1857FBD208	0xF001 D830	0XXXX XX00
LPC18S57JBD208	0xF001 D860	0XXXX XX00
LPC1853FET256	0xF001 D830	0XXXX XX44
LPC1853FET180	0xF001 D830	0XXXX XX44
LPC1853FBD208	0xF001 D830	0XXXX XX44
LPC1837FET256	0xF001 DA30	0XXXX XX00
LPC1837FET180	0xF001 DA30	0XXXX XX00
LPC1837FET100	0xF001 DA30	0XXXX XX00
LPC1837FBD144	0xF001 DA30	0XXXX XX00
LPC18S37JET100	0xF001 DA60	0XXXX XX00
LPC18S37JBD144	0xF001 DA60	0XXXX XX00
LPC1833FET256	0xF001 DA30	0XXXX XX44
LPC1833FET180	0xF001 DA30	0XXXX XX44
LPC1833FET100	0xF001 DA30	0XXXX XX44
LPC1833FBD144	0xF001 DA30	0XXXX XX44
LPC1827JBD144	0xF001 DB3C	0XXXX XX00
LPC1827JET100	0xF001 DB3C	0XXXX XX00
LPC1825JBD144	0xF001 DB3C	0XXXX XX22
LPC1825JET100	0xF001 DB3C	0XXXX XX22
LPC1823JBD144	0xF00B DB3C	0XXXX XX44
LPC1823JET100	0xF00B DB3C	0XXXX XX44
LPC1822JBD144	0xF00B DB3C	0XXXX XX80
LPC1822JET100	0xF00B DB3C	0XXXX XX80
LPC1817JBD144	0xF001 DB3F	0XXXX XX00
LPC1817JET100	0xF001 DB3F	0XXXX XX00
LPC1815JBD144	0xF001 DB3F	0XXXX XX22

Table 39. LPC18xx part identification numbers

Device	Hex coding	
	Word0	Word1
LPC1815JET100	0xF001 DB3F	0xFFFF XX22
LPC1813JBD144	0xF00B DB3F	0xFFFF XX44
LPC1813JET100	0xF00B DB3F	0xFFFF XX44
LPC1812JBD144	0xF00B DB3F	0xFFFF XX80
LPC1812JET100	0xF00B DB3F	0xFFFF XX80

5.7.12 Read Boot Code version number

Table 40. ISP Read Boot Code version number command

Command	K
Input	None
Return Code	CMD_SUCCESS followed by 2 bytes of boot code version number in ASCII format. It is to be interpreted as <byte1(Major)>.<byte0(Minor)>.
Description	This command is used to read the boot code version number.

5.7.13 Read device serial number

Table 41. ISP Read device serial number command

Command	N
Input	None.
Return Code	CMD_SUCCESS followed by the device serial number in 4 decimal ASCII groups, each representing a 32-bit value.
Description	This command is used to read the device serial number. The serial number may be used to uniquely identify a single unit among all LPC18xx devices.

5.7.14 Compare <address1> <address2> <no of bytes>

Table 42. ISP Compare command

Command	M
Input	<p>Address1 (DST): Starting flash or RAM address of data bytes to be compared. This address should be a word boundary.</p> <p>Address2 (SRC): Starting flash or RAM address of data bytes to be compared. This address should be a word boundary.</p> <p>Number of Bytes: Number of bytes to be compared; should be a multiple of 4.</p>
Return Code	CMD_SUCCESS (Source and destination data are equal) COMPARE_ERROR (Followed by the offset of first mismatch) COUNT_ERROR (Byte count is not a multiple of 4) ADDR_ERROR ADDR_NOT_MAPPED PARAM_ERROR
Description	This command is used to compare the memory contents at two locations. This command is blocked when any level of code read protection is enabled.
Example	"M 436207616 268435968 4<CR><LF>" compares 4 bytes from the RAM address 0x1000 0200 to the 4 bytes from the flash address 0x1A00 0000.

5.7.15 Set active boot flash bank <flash bank>

This command is only valid if two flash banks exist on the part and selects one of the two banks for booting from flash. The command inserts a valid signature (see [Section 5.4.4.1](#)) in the selected flash bank and invalidates the signature in the other flash bank. After a reset, the part will boot from the selected flash bank and apply any code read protection (CRP) that is included in the flash image of the selected bank to the entire flash (bank A and bank B).

The set active boot flash bank command is disabled with CRP levels 1, 2, and 3. This means that the boot flash bank cannot be changed if CRP is enabled. If CRP is included in the new flash image to be activated by this command, ensure that the flash image content is executing as expected. Otherwise, the part may fail to boot after reset and, for CRP level 3, external boot or ISP may not be accessible to update the flash.

Table 43. ISP Set active boot flash bank command

Command	S
Input	Flash bank: Selects flash bank A or B for booting if the part supports more than one bank. (0 = flash bank A, 1 = flash bank B).
Return Code	INVALID_FLASH_UNIT INVALID_SECTOR COMPARE_ERROR USER_CODE_CHECKSUM DST_ADDR_ERROR BUSY ERROR_SETTING_ACTIVE_PARTITION
Description	This command is only valid if there are two flash banks. It is used to enable booting from the indicated flash unit by inserting valid signature and invalidating the other flash unit. This command will not work if zeros are found where a vector table is expected. Remark: An invalid image in the selected flash unit can cause boot failure and even a system lockup when CRP3 is set.
Example	"S 0 <CR><LF>" selects flash bank A

5.8 IAP commands

Remark: IAP commands are not supported for flash-less parts.

For in-application programming, call the IAP routine with a word pointer in register r0 pointing to memory (RAM) containing command code and parameters.

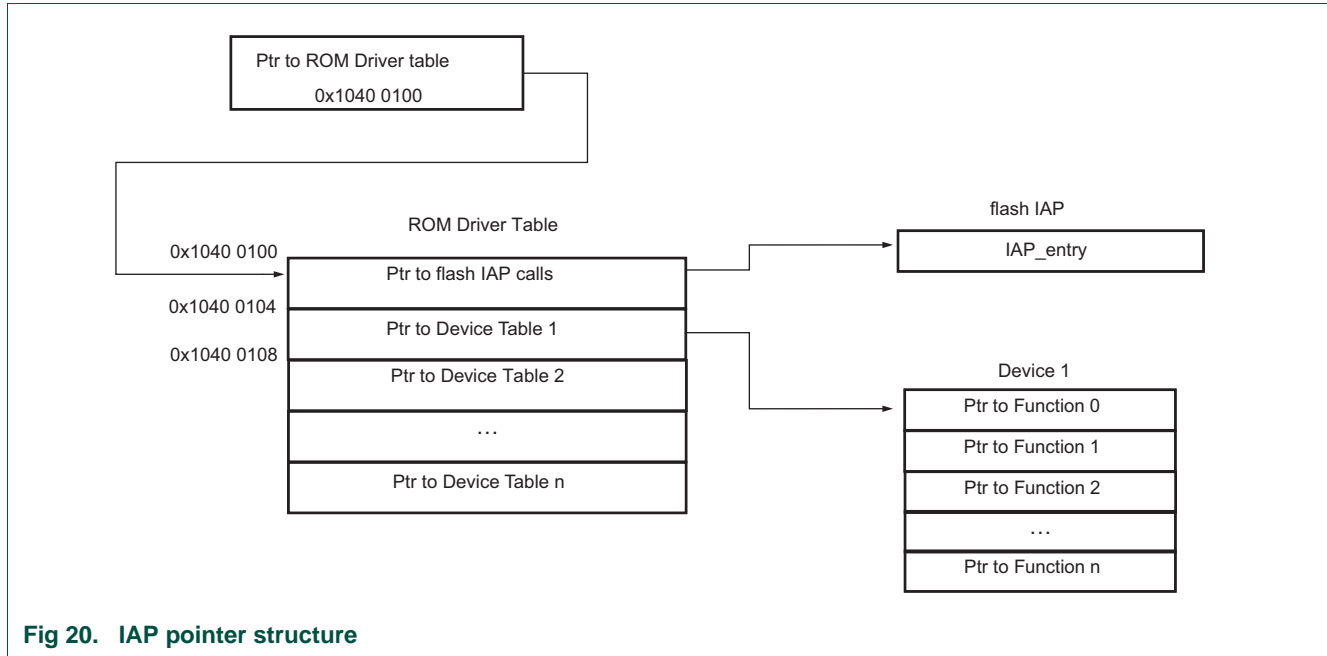

Fig 20. IAP pointer structure

The result of the IAP command is returned in the result table pointed to by register r1. You can reuse the command table for result by passing the same pointer in registers r0 and r1. The parameter table should be big enough to hold all the results in case the number of results are more than number of parameters. Parameter passing is illustrated in [Figure 21](#). The number of parameters and results vary according to the IAP command. The maximum number of parameters is 4, passed to the "Copy RAM to Flash" command. The maximum number of results is 4, returned by the "Read device serial number" command. The command handler sends the status code INVALID_COMMAND when an undefined command is received.

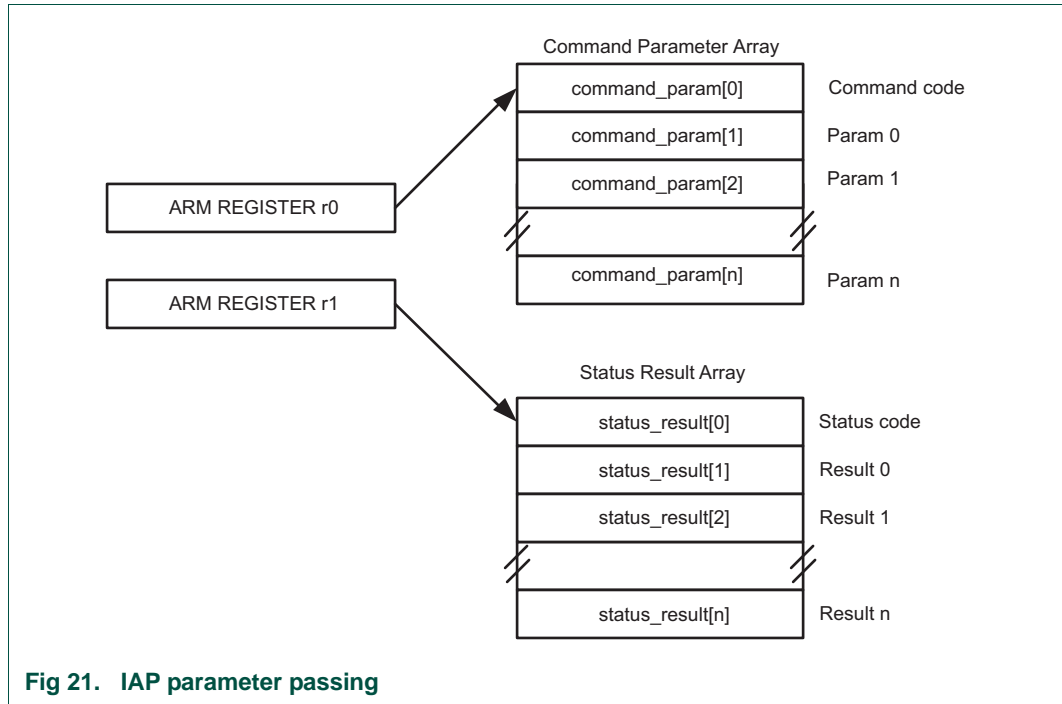

Fig 21. IAP parameter passing

In C code, call the IAP function in the following way:

1. Extract the IAP invoke call (iap_entry) entry pointer. The IAP invoke call is located in the IAP jump table which is pointed to by the ROM driver table at address 0x1040 0100 + 0x000. See [Figure 20](#).
2. Define data structure or pointers to pass the IAP command table and result table to the IAP function:

```
unsigned int command_param[5];
unsigned int status_result[5];
```

or

```
unsigned int * command_param;
unsigned int * status_result;
command_param = (unsigned int *) 0x...
status_result = (unsigned int *) 0x...
```

3. Define a pointer to function type, which takes two parameters and returns void. Note the IAP returns the result with the base address of the table residing in R1:

```
#define IAP_LOCATION *(volatile unsigned int *) (0x10400100);
typedef void (*IAP)(unsigned int [], unsigned int []);
```

4. Set the function pointer:

```
IAP iap_entry=(IAP)IAP_LOCATION;
```

5. Use the following statement to call the IAP:

```
iap_entry (command_param,status_result);
```

The IAP call can be simplified further by using the symbol definition file feature supported by ARM Linker in RVDS (Realview Development Suite). You can also call the IAP routine using assembly code. According to the ARM architecture Procedure Calling Standard (AAPCS), up to 4 parameters can be passed in the r0, r1, r2 and r3 registers respectively. Additional parameters are passed on the stack. Up to 4 parameters can be returned in the r0, r1, r2 and r3 registers respectively. Additional parameters are returned indirectly via memory. Some of the IAP calls require more than 4 parameters. If the ARM suggested scheme is used for the parameter passing/returning then it might create problems due to difference in the C compiler implementation from different vendors. The suggested parameter passing scheme reduces this risk.

The flash memory is not accessible during a write or an erase operation. IAP commands which result in a flash write/erase operation use 32 bytes of space in the top portion of the on-chip RAM for execution. The user program should not be using this space if IAP flash programming is permitted in the application. Maximum stack usage is mentioned in the description of a command.

Table 44. IAP Command Summary

IAP Command	Command Code	Reference
Init	49 ₁₀	Table 45
Prepare sectors for write operation	50 ₁₀	Table 46
Copy RAM to Flash	51 ₁₀	Table 47
Erase sectors	52 ₁₀	Table 48
Blank check sectors	53 ₁₀	Table 49
Read part ID	54 ₁₀	Table 50
Read Boot Code version	55 ₁₀	Table 51
Read device serial number	58 ₁₀	Table 52
Compare	56 ₁₀	Table 53
Reinvoke ISP	57 ₁₀	Table 54
Erase page	59 ₁₀	Table 55
Set active boot flash bank	60 ₁₀	Table 56

5.8.1 IAP Initialization

This command initializes and prepares the flash for erase and write operations.

Table 45. IAP Initialization command

Command	Init IAP
Input	Command code: 49 (decimal)
Return Code	CMD_SUCCESS

Table 45. IAP Initialization command

Command	Init IAP
Result	None
Description	Initializes and prepares the flash for erase and write operations.
Stack usage	88 B

5.8.2 Prepare sectors for write operation

This command is the first step in the two-step flash write/erase operation.

Table 46. IAP Prepare sectors for write operation command

Command	Prepare sectors for write operation
Input	Command code: 50 (decimal) Param0: Start Sector Number Param1: End Sector Number (should be greater than or equal to start sector number). Param2: Flash bank (0 = flash bank A, 1 = flash bank B)
Return Code	CMD_SUCCESS BUSY INVALID_SECTOR
Result	None
Description	This command must be executed before executing "Copy RAM to Flash" or "Erase Sectors" command. Successful execution of the "Copy RAM to Flash" or "Erase Sectors" command causes relevant sectors to be protected again. To prepare a single sector use the same "Start" and "End" sector numbers.
Stack usage	118 B

5.8.3 Copy RAM to Flash

Before executing this command, perform the “Prepare sectors for write” command.

Table 47. IAP Copy RAM to Flash command

Command	Copy RAM to Flash
Input	<p>Command code: 51 (decimal)</p> <p>Param0(DST): Destination flash address where data bytes are to be written. This address should be a 512 byte boundary.</p> <p>Param1(SRC): Source internal SRAM address from which data bytes are to be read. This address should be a word boundary.</p> <p>Param2: Number of bytes to be written. Should be 512 1024 4096.</p> <p>Param3: CPU Clock Frequency (CCLK) in kHz.</p>
Return Code	CMD_SUCCESS SRC_ADDR_ERROR (Address not a word boundary) DST_ADDR_ERROR (Address not on correct boundary) SRC_ADDR_NOT_MAPPED DST_ADDR_NOT_MAPPED COUNT_ERROR (Byte count is not 512 1024 4096) SECTOR_NOT_PREPARED_FOR_WRITE_OPERATION BUSY
Result	None
Description	This command is used to program the flash memory. The affected sectors should be prepared first by calling "Prepare Sector for Write Operation" command. The affected sectors are automatically protected again once the copy command is successfully executed.
Stack usage	208 B

5.8.4 Erase Sectors

Table 48. IAP Erase Sectors command

Command	Erase Sectors
Input	<p>Command code: 52 (decimal)</p> <p>Param0: Start Sector Number</p> <p>Param1: End Sector Number (should be greater than or equal to start sector number).</p> <p>Param2: CPU Clock Frequency (CCLK) in kHz.</p> <p>Param3: Flash bank (0 = flash bank A, 1 = flash bank B)</p>
Return Code	CMD_SUCCESS BUSY SECTOR_NOT_PREPARED_FOR_WRITE_OPERATION INVALID_SECTOR INVALID_FLASH_UNIT
Result	None
Description	This command is used to erase a sector or multiple sectors of on-chip flash memory. To erase a single sector use the same "Start" and "End" sector numbers.
Stack usage	136 B

5.8.5 Blank check sectors

Table 49. IAP Blank check sectors command

Command	Blank check sectors
Input	Command code: 53 (decimal) Param0: Start Sector Number Param1: End Sector Number (should be greater than or equal to start sector number). Param2: Flash bank (0 = flash bank A, 1 = flash bank B)
Return Code	CMD_SUCCESS BUSY SECTOR_NOT_BLANK INVALID_SECTOR INVALID_FLASH_UNIT
Result	Result0: Offset of the first non blank word location if the Status Code is SECTOR_NOT_BLANK. Result1: Contents of non blank word location.
Description	This command is used to blank check a sector or multiple sectors of on-chip flash memory. To blank check a single sector use the same "Start" and "End" sector numbers.
Stack usage	120 B

5.8.6 Read part identification number

Table 50. IAP Read part identification number command

Command	Read part identification number
Input	Command code: 54 (decimal) Parameters: None
Return Code	CMD_SUCCESS
Result	Result0: Part Identification Number. Result1: Part Identification Number.
Description	This command is used to read the part identification number. See Table 39 "LPC18xx part identification numbers". The command returns two words: word0 followed by word1. Word 0 corresponds to the part id and word1 indicates the flash configuration or contains 0x0 for flashless parts.
Stack usage	8 B

5.8.7 Read Boot Code version number

Table 51. IAP Read Boot Code version number command

Command	Read boot code version number
Input	Command code: 55 (decimal) Parameters: None
Return Code	CMD_SUCCESS

Table 51. IAP Read Boot Code version number command

Command	Read boot code version number
Result	Result0: 2 bytes of boot code version number. It is to be interpreted as <byte1(Major)>.<byte0(Minor)>
Description	This command is used to read the boot code version number.
Stack usage	8 B

5.8.8 Read device serial number

Table 52. IAP Read device serial number command

Command	Read device serial number
Input	Command code: 58 (decimal) Parameters: None
Return Code	CMD_SUCCESS
Result	Result0: First 32-bit word of Device Identification Number (at the lowest address) Result1: Second 32-bit word of Device Identification Number Result2: Third 32-bit word of Device Identification Number Result3: Fourth 32-bit word of Device Identification Number
Description	This command is used to read the device identification number. The serial number may be used to uniquely identify a single unit among all LPC18xx devices.
Stack usage	8 B

5.8.9 Compare <address1> <address2> <no of bytes>

Table 53. IAP Compare command

Command	Compare
Input	Command code: 56 (decimal) Param0(DST): Starting flash or RAM address of data bytes to be compared. This address should be a word boundary. Param1(SRC): Starting flash or RAM address of data bytes to be compared. This address should be a word boundary. Param2: Number of bytes to be compared; should be a multiple of 4.
Return Code	CMD_SUCCESS COMPARE_ERROR COUNT_ERROR (Byte count is not a multiple of 4) ADDR_ERROR ADDR_NOT_MAPPED
Result	Result0: Offset of the first mismatch if the Status Code is COMPARE_ERROR.
Description	This command is used to compare the memory contents at two locations. The result may not be correct when the source or destination includes any of the first 64 bytes starting from address zero. The first 64 bytes can be re-mapped to RAM.
Stack usage	152 B

5.8.10 Re-invoke ISP

Table 54. IAP Re-invoke ISP

Command	Compare
Input	Command code: 57 (decimal)
Return Code	None
Result	None.
Description	This command is used to invoke the boot loader in ISP mode. It configures UART0 pins U0_RX and U0_TX. Use this command when a valid user program is present in the internal flash memory and the P2_7 pin is not accessible to force the ISP mode. The command does not change CCLK, It does sets the source dependent clock accordingly assuming that PLL1 is running at 288 MHz.
Stack usage	192 B

5.8.11 Erase page

The erase page command allows to erase one page (512 B) in a given sector.

Table 55. IAP Erase page

Command	Erase page
Input	Command code: 59 (decimal) Param0: Start flash address. Param1: End flash address. Param2: CPU clock frequency in kHz.
Return Code	CMD_SUCCESS BUSY SECTOR_NOT_PREPARED_FOR_WRITE_OPERATION INVALID_SECTOR INVALID_FLASH_UNIT
Result	None.
Description	This command is used to erase a page or multiple pages of on-chip flash memory. To erase a single page use the same "Start" and "End" flash address. Start and End addresses must be in the same sector.
Stack usage	168 B

5.8.12 Set active boot flash bank

This command is only valid if two flash banks exist on the part and selects one of the two banks for booting from flash. The command inserts a valid signature (see [Section 5.4.4.1](#)) in the selected flash bank and invalidates the signature in the other flash bank. After a reset, the part will boot from the selected flash bank and apply any code read protection (CRP) that is included in the flash image of the selected bank to the entire flash (bank A and bank B).

The set active boot flash bank command is disabled with CRP levels 1, 2, and 3. This means that the boot flash bank cannot be changed if CRP is enabled. If CRP is included in the new flash image to be activated by this command, ensure that the flash image content is executing as expected. Otherwise, the part may fail to boot after reset and, for CRP level 3, external boot or ISP may not be accessible to update the flash.

Remark: This command uses a large stack space. See [Table 56](#).

Table 56. IAP Set active boot flash bank

Command	Set active boot flash bank
Input	Command code: 60 (decimal) Param0: Flash bank (0 = flash bank A, 1 = flash bank B). Param1: CPU clock frequency in kHz.
Return Code	CMD_SUCCESS BUSY SECTOR_NOT_PREPARED_FOR_WRITE_OPERATION INVALID_SECTOR INVALID_FLASH_UNIT ERROR_USER_CODE_CHECKSUM ERROR_SETTING_ACTIVE_PARTITION
Result	None.
Description	This command is only valid if there are two flash banks. It is used to enable booting from the indicated flash unit by inserting a valid signature and invalidating the other flash unit. This command will not work if zeros are found where a vector table is expected. Remark: An invalid image in the selected flash unit can cause boot failure and even a system lockup when CRP3 is set.
Stack usage	2208 B

5.9 ISP/IAP Return Codes

Table 57. ISP Return Codes Summary

Return Code	Mnemonic	Description
0x0000 0000	CMD_SUCCESS	Command is executed successfully. Sent by ISP handler only when command given by the host has been completely and successfully executed.
0x0000 0001	INVALID_COMMAND	Invalid command.
0x0000 0002	SRC_ADDR_ERROR	Source address is not on word boundary.
0x0000 0003	DST_ADDR_ERROR	Destination address not on word or 256 byte boundary.
0x0000 0004	SRC_ADDR_NOT_MAPPED	Source address is not mapped in the memory map. Count value is taken into consideration where applicable.
0x0000 0005	DST_ADDR_NOT_MAPPED	Destination address is not mapped in the memory map. Count value is taken into consideration where applicable.
0x0000 0006	COUNT_ERROR	Byte count is not multiple of 4 or is not a permitted value.
0x0000 0007	INVALID_SECTOR	Sector number is invalid or end sector number is greater than start sector number.
0x0000 0008	SECTOR_NOT_BLANK	Sector is not blank.
0x0000 0009	SECTOR_NOT_PREPARED_FOR_WRITE_OPERATION	Command to prepare sector for write operation was not executed.
0x0000 000A	COMPARE_ERROR	Source and destination data not equal.
0x0000 000B	BUSY	Flash programming hardware interface is busy.
0x0000 000C	PARAM_ERROR	Insufficient number of parameters or invalid parameter.
0x0000 000D	ADDR_ERROR	Address is not on word boundary.
0x0000 000E	ADDR_NOT_MAPPED	Address is not mapped in the memory map. Count value is taken in to consideration where applicable.
0x0000 000F	CMD_LOCKED	Command is locked.
0x0000 0010	INVALID_CODE	Unlock code is invalid.
0x0000 0011	INVALID_BAUD_RATE	Invalid baud rate setting.

Table 57. ISP Return Codes Summary

Return Code	Mnemonic	Description
0x0000 0012	INVALID_STOP_BIT	Invalid stop bit setting.
0x0000 0013	CODE_READ_PROTECTION_ENABLED	Code read protection enabled.
0x0000 0014	INVALID_FLASH_UNIT	Invalid flash unit.
0x0000 0015	USER_CODE_CHECKSUM	
0x0000 0016	ERROR_SETTING_ACTIVE_PARTITION	

5.10 JTAG flash programming interface

Debug tools can write parts of the flash image to the RAM and then execute the IAP call "Copy RAM to Flash" repeatedly with proper offset.

5.11 Flash signature generation

The flash module contains a built-in signature generator. This generator can produce a 128-bit signature from a range of flash memory. A typical usage is to verify the flashed contents against a calculated signature (e.g. during programming).

The address range for generating a signature must be aligned on flash-word boundaries, i.e. 128-bit boundaries. Once started, signature generation completes independently. While signature generation is in progress, the flash memory cannot be accessed for other purposes, and an attempted read will cause a wait state to be asserted until signature generation is complete. Code outside of the flash (e.g. internal RAM) can be executed during signature generation. This can include interrupt services, if the interrupt vector table is re-mapped to memory other than the flash memory. The code that initiates signature generation should also be placed outside of the flash memory.

5.11.1 Register description for signature generation

Table 58. Register overview: FMC controller for flash bank A/B (base address 0x4000 C000 (flash bank A) and 0x4000 D000 (flash bank B))

Name	Access	Address offset	Description	Reset Value	Reference
FMSSTART	R/W	0x020	Signature start address register	0	Table 59
FMSSTOP	R/W	0x024	Signature stop-address register	0	Table 60
FMSW0	R	0x02C	128-bit signature Word 0	-	Table 61
FMSW1	R	0x030	128-bit signature Word 1	-	Table 62
FMSW2	R	0x034	128-bit signature Word 2	-	Table 63
FMSW3	R	0x038	128-bit signature Word 3	-	Table 64
FMSTAT	R	0xFE0	Signature generation status register	0	Table 65
FMSTATCLR	W	0xFE8	Signature generation status clear register	-	Table 66

5.11.1.1 Signature generation address and control registers

These registers control automatic signature generation. A signature can be generated for any part of the flash memory contents. The address range to be used for generation is defined by writing the start address to the signature start address register (FMSSTART) and the stop address to the signature stop address register (FMSSTOP. The start and stop addresses must be aligned to 128-bit boundaries and can be derived by dividing the byte address by 16.

Signature generation is started by setting the SIG_START bit in the FMSSTOP register. Setting the SIG_START bit is typically combined with the signature stop address in a single write.

[Table 59](#) and [Table 60](#) show the bit assignments in the FMSSTART and FMSSTOP registers respectively.

Table 59. Flash Module Signature Start register (FMSSTART, address 0x4000 C020 (flash A) and 0x4000 D020 (flash B)) bit description

Bit	Symbol	Description	Reset Value
31:17	-	Reserved, user software should not write ones to reserved bits. The value read from a reserved bit is not defined.	NA
16:0	START	Signature generation start address (corresponds to AHB byte address bits[20:4]).	0

Table 60. Flash Module Signature Stop register (FMSSTOP , address 0x4000 C024 (flash A) and 0x4000 D024 (flash B)) bit description

Bit	Symbol	Value	Description	Reset Value
31:18	-		Reserved, user software should not write ones to reserved bits. The value read from a reserved bit is not defined.	NA
17	SIG_START		Start control bit for signature generation.	0
		0	Signature generation is stopped	
		1	Initiate signature generation	
16:0	STOP		BIST stop address divided by 16 (corresponds to AHB byte address [20:4]).	0

5.11.1.2 Signature generation result registers

The signature generation result registers return the flash signature produced by the embedded signature generator. The 128-bit signature is reflected by the four registers FMSW0, FMSW1, FMSW2 and FMSW3.

The generated flash signature can be used to verify the flash memory contents. The generated signature can be compared with an expected signature and thus makes saves time and code space. The method for generating the signature is described in [Section 5.11.2](#).

[Table 64](#) show bit assignment of the FMSW0 and FMSW1, FMSW2, FMSW3 registers respectively.

Table 61. FMSW0 register bit description (FMSW0, address 0x4000 C02C (flash A) and 0x4000 D02C (flash B))

Bit	Symbol	Description	Reset Value
31:0	SW0[31:0]	Word 0 of 128-bit signature (bits 31 to 0).	-

Table 62. FMSW1 register bit description (FMSW1, address: 0x4000 C030 (flash A) and 0x4000 D030 (flash B))

Bit	Symbol	Description	Reset Value
31:0	SW1[63:32]	Word 1 of 128-bit signature (bits 63 to 32).	-

Table 63. FMSW2 register bit description (FMSW2, address 0x4000 C034 (flash A) and 0x4000 D034 (flash B))

Bit	Symbol	Description	Reset Value
31:0	SW2[95:64]	Word 2 of 128-bit signature (bits 95 to 64).	-

Table 64. FMSW3 register bit description (FMSW3, address 0x4000 C038 (flash A) and 0x4000 D038 (flash B))

Bit	Symbol	Description	Reset Value
31:0	SW3[127:96]	Word 3 of 128-bit signature (bits 127 to 96).	-

5.11.1.3 Flash Module Status register

The read-only FMSTAT register provides a means of determining when signature generation has completed. Completion of signature generation can be checked by polling the SIG_DONE bit in FMSTAT. SIG_DONE should be cleared via the FMSTATCLR register before starting a signature generation operation, otherwise the status might indicate completion of a previous operation.

Table 65. Flash module Status register (FMSTAT, address 0x4000 CFE0 (flash A) and 0x4000 DFE0 (flash B)) bit description

Bit	Symbol	Description	Reset Value
31:2	-	Reserved, user software should not write ones to reserved bits. The value read from a reserved bit is not defined.	NA
2	SIG_DONE	When 1, a previously started signature generation has completed. See FMSTATCLR register description for clearing this flag.	0
1:0	-	Reserved, user software should not write ones to reserved bits. The value read from a reserved bit is not defined.	NA

5.11.1.4 Flash Module Status Clear register

The FMSTATCLR register is used to clear the signature generation completion flag.

Table 66. Flash Module Status Clear register (FMSTATCLR, address 0x4000 CFE8 (flash A) and 0x4000 DFE8 (flash B)) bit description

Bit	Symbol	Description	Reset Value
31:2	-	Reserved, user software should not write ones to reserved bits. The value read from a reserved bit is not defined.	NA
2	SIG_DONE_CLR	Writing a 1 to this bits clears the signature generation completion flag (SIG_DONE) in the FMSTAT register.	0
1:0	-	Reserved, user software should not write ones to reserved bits. The value read from a reserved bit is not defined.	NA

5.11.2 Algorithm and procedure for signature generation

Signature generation

A signature can be generated for any part of the flash contents. The address range to be used for signature generation is defined by writing the start address to the FMSSTART register, and the stop address to the FMSSTOP register.

The signature generation is started by writing a '1' to FMSSTOP.MISR_START. Starting the signature generation is typically combined with defining the stop address, which is done in another field FMSSTOP.FMSSTOP of the same register.

The time that the signature generation takes is proportional to the address range for which the signature is generated. Reading of the flash memory for signature generation uses a self-timed read mechanism and does not depend on any configurable timing settings for the flash. A safe estimation for the duration of the signature generation is:

$$\text{Duration} = \text{int}((60 / \text{tcy}) + 3) \times (\text{FMSSTOP} - \text{FMSSTART} + 1)$$

When signature generation is triggered via software, the duration is in AHB clock cycles, and tcy is the time in ns for one AHB clock. The SIG_DONE bit in FMSTAT can be polled by software to determine when signature generation is complete.

If signature generation is triggered via JTAG, the duration is in JTAG tck cycles, and tcy is the time in ns for one JTAG clock. Polling the SIG_DONE bit in FMSTAT is not possible in this case.

After signature generation, a 128-bit signature can be read from the FMSW0 to FMSW3 registers. The 128-bit signature reflects the corrected data read from the flash. The 128-bit signature reflects flash parity bits and check bit values.

Content verification

The signature as it is read from the FMSW0 to FMSW3 registers must be equal to the reference signature. The algorithms to derive the reference signature is given in [Figure 22](#).

```

sign = 0
FOR address = FMSTART.FMSTART TO FMSTOP.FMSTOP
{
    FOR i = 0 TO 126
        nextSign[i] = f_Q[address][i] XOR sign[i+1]
        nextSign[127] = f_Q[address][127] XOR sign[0] XOR sign[2] XOR
            sign[27] XOR sign[29]
    sign = nextSign
}
signature128 = sign

```

Fig 22. Algorithm for generating a 128 bit signature

6.1 How to read this chapter

AES encryption and decryption and the AES API are supported for parts LPC18Sxx only.

6.2 Features

- Decryption of external image data.
- Encryption of data.
- Secure storage of AES keys.
- Support for Cypher-based Message Authentication Code (CMAC) hash calculation to authenticate data (for the boot image only).
- Support for two secret hardware keys that cannot be read.
- AES engine peak performance of 0.5 byte/clock cycle.
- AES API supports:
 - Electronic Code Book (ECB) decode mode with 128-bit key.
 - Cypher-Block Chaining (CBC) decode mode with 128-bit key.
 - CMAC hash calculation for the boot image (see [Section 7.3.4](#)).
- The AES engine is compliant with the FIPS (Federal Information Processing Standard) Publication 197, Advanced Encryption Standard (AES).
- Random Number Generator (RNG) is supported by the AES API and passes the following tests:
 - diehard
 - FIPS_140-1
 - NIST
- Data is processed in little endian mode. This means that the first byte read from flash is integrated into the AES codeword as least significant byte. The 16th byte read from flash is the most significant byte of the first AES codeword.
- DMA transfers supported through the GPDMA.

Details of the AES decryption pertaining to the boot process are described in [Chapter 7](#).

Remark: For other decode modes (Cipher Feedback (CFB), Output Feedback (OFB), and Counter (CTR)), please contact the NXP sales office.

6.3 General description

The secure parts provide an on-chip hardware AES decryption and encryption engine to protect the external image content and to accelerate processing for data decryption, data integrity, and proof of origin. AES decryption can be applied to an external boot image using a key that is itself encrypted and is stored in the OTP. This key cannot be read by software or by any other means, and its encryption is unique for each part. In addition, data can be encrypted or decrypted by the AES engine using the encrypted key in the

OTP, a second key stored in the OTP (this key is not encrypted), a software supplied key, or a key generated by an on-chip random number generator. For encryption and decryption of data, an API is provided.

The AES hardware consists of these components:

- One-time programmable (OTP) non-volatile memory to store the AES keys. Two instances (OTP1/2) are offered to store the two keys using the AES API ([Table 67](#)).
- An AES decryption engine. The AES uses a 128-bit key and processes blocks of 128 bit. Using the AES API, the keys can be stored in a dedicated hardware interface that is not visible to software.
- The AES encryption engine. Encryption is selected through the AES_SetMode command. The command returns an error if the parts are not configured for encryption.
- The AES encryption and decryption engine supports DMA for transferring data between memory and the AES engine.
- The ROM-based AES API for encrypting and decrypting data, storing and retrieving keys, and for interfacing with the GPDMA.

The AES engine can be loaded with four different keys:

1. Key1 - user-defined and stored in the OTP uniquely encrypted for each part; used by the boot code to decrypt boot image; can also be used to encrypt or decrypt data. This key is the most secure key, as the original, programmed key is encrypted in the OTP memory on-chip and cannot be read by software.
2. Key2 - user-defined and stored in the OTP; used to encrypt or decrypt data.
3. A software defined key.
4. A key generated by the Random Number Generator (RNG).

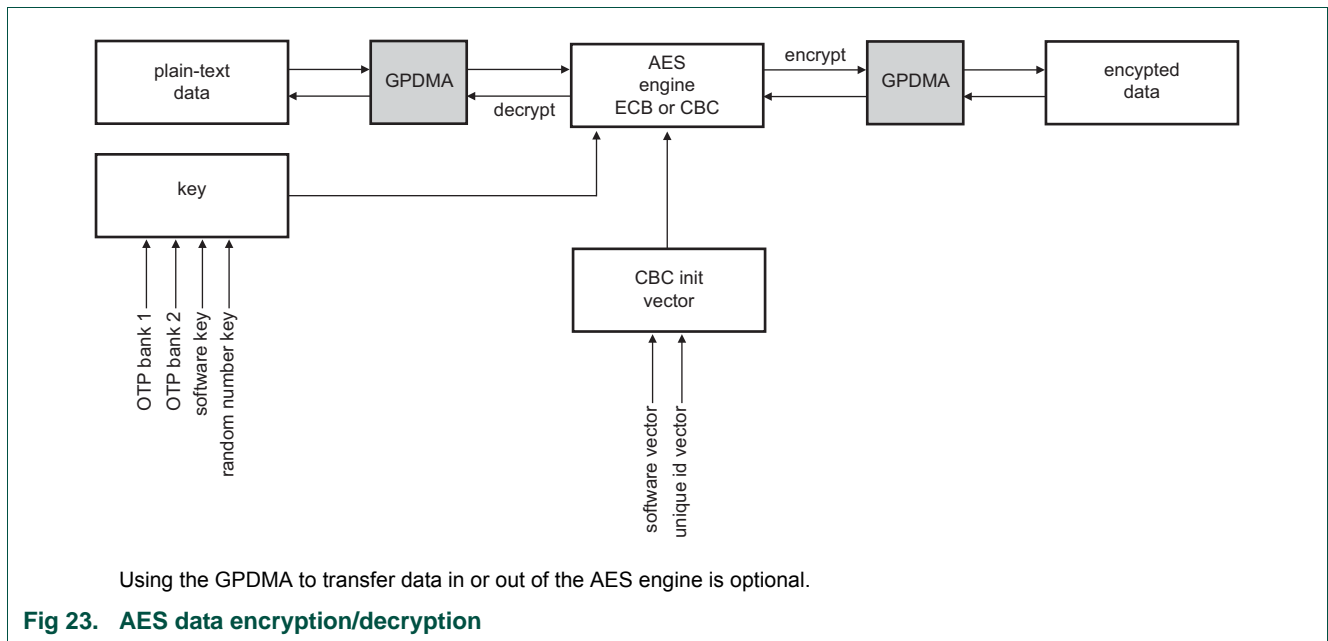

Remark: The randomly generated and software defined keys are not retained during Deep power-down and reset and must be reloaded.

Remark: To update the Random Number Generator (RNG) and load a new random number, first use the otp_GenRand() API call, and then the aes_LoadKeyRNG() call (see [Section 6.5.6](#)).

6.4 AES API

The AES is controlled through a set of simple API calls located in the LPC18Sxx ROM.

The API calls to the ROM are performed by executing functions which are pointed to by pointer within the ROM driver table.

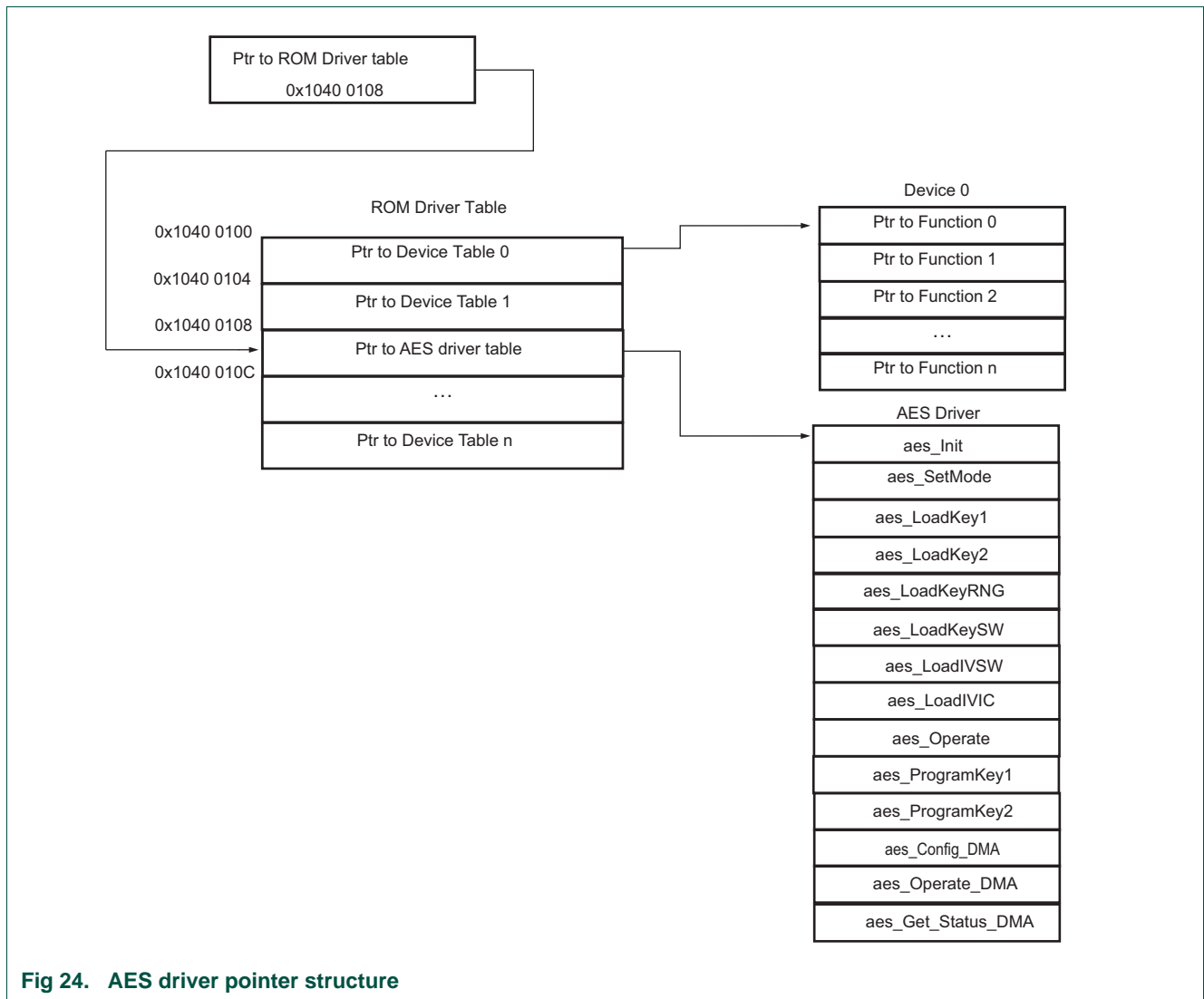

Fig 24. AES driver pointer structure

6.4.1 AES functions

The ROM-based security AES API controls the AES block. AES API functions are provided to encrypt or decrypt data from memory to memory using an ECB or CBC algorithm. If the CBC algorithm is selected, a user-defined initialization vector can be defined.

To transfer data between memory and the AES peripheral using the GPDMA, additional API functions are provided that configure the GPDMA, DMA peripheral input mux, and the AES appropriately.

The AES API can load one of four keys to encrypt or decrypt data:

- Key1 stored in OTP memory bank 1. This is a secure key used by the boot code for decrypting the boot image.
- Key2 stored in OTP memory bank 2.
- A software-generated key.
- A key generated by the on-chip random number generator.

Two APIs are provided to store keys in the OTP memory banks 1 and 2.

Table 67. AES API calls

Function	Offset relative to the API entry point	Description
aes_Init	0x00	Initialize AES engine Parameter - void Return - void
aes_SetMode	0x04	Defines AES engine operation mode Parameter: unsigned cmd with values: 0 - ECB encode AES_API_CMD_ENCODE_ECB (if the parts are not configured for encryption, using aes_SetMode with this parameter returns an error) 1 - ECB decode AES_API_CMD_DECODE_ECB 2 - CBC encode AES_API_CMD_ENCODE_CBC (if the parts are not configured for encryption, using aes_SetMode with this parameter returns an error) 3 - CBC decode AES_API_CMD_DECODE_CBC Return - unsigned: see general error codes.
aes_LoadKey1	0x08	Loads 128-bit AES user key 1 Parameter - void Return - unsigned: see general error codes.
aes_LoadKey2	0x0C	Loads 128-bit AES user key 2 Parameter - void Return - unsigned: see general error codes.
aes_LoadKeyRNG	0x10	Loads randomly generated key in AES engine. To update the RNG and load a new random number, use the API call otp_GenRand before aes_LoadKeyRNG. Parameter - void Return - void

Table 67. AES API calls

Function	Offset relative to the API entry point	Description
aes_LoadKeySW	0x14	Loads 128-bit AES software defined user key Parameter - unsigned char *key(16 bytes) Return - unsigned: see general error codes.
aes_LoadIV_SW	0x18	Loads 128-bit AES initialization vector Parameter - unsigned char *iv(16 bytes) Return - unsigned: see general error codes.
aes_LoadIV_IC	0x1C	Loads 128-bit AES IC specific initialization vector, which is used to decrypt a boot image. Parameter - void Return - unsigned: see general error codes.
aes_Operate	0x20	Performs the AES encryption or decryption after the AES mode has been set using aes_Set_Mode and the appropriate keys and init vectors have been loaded. Parameter1 - unsigned char *data_out Parameter2 - unsigned char *data_in Parameter3 - unsigned size (128-bit word - 16 byte) Return - unsigned: see general error codes.
aes_ProgramKey1	0x24	Programs 128-bit AES key in OTP. Parameter: unsigned char *key (16 byte) Return - unsigned: see general error codes. Remark: When calling the aes_ProgramKey1 function, ensure that VPP = 2.7 V to 3.6 V.
aes_ProgramKey2	0x28	Programs 128-bit AES key in OTP. Parameter: unsigned char *key (16 byte) Return - unsigned: see general error codes. Remark: When calling the aes_ProgramKey2 function, ensure that VPP = 2.7 V to 3.6 V.

Table 67. AES API calls

Function	Offset relative to the API entry point	Description
aes_Config_DMA	0x2C	Checks for valid AES configuration of the chip and setup DMA channel to process an AES data block. Parameter: unsigned channel_id Return - unsigned: AES_API_ERROR_NOT_SUPPORTED AES_API_ERROR_DMA_CHANNEL_CFG AES_API_ERROR_DMA_MUX_CFG AES_API_NO_ERROR
aes_Operate_DMA	0x30	Checks for valid AES configuration of the chip and enables DMA channel to process an AES data block. Parameter1: unsigned channel_id. Parameter2: unsigned char *dataOutAddr (16 x size of consecutive bytes) Parameter3: unsigned char *dataInAddr (16 x size of consecutive bytes) Parameter4: unsigned size (number of 128 bit AES blocks) Return – unsigned: AES_API_ERROR_NOT_SUPPORTED AES_API_NO_ERROR
aes_Get_Status_DMA	0x34	Read status of DMA channels that process an AES data block. Parameter: channel_id. Return – unsigned: AES_API_NO_ERROR AES_API_DMA_BUSY

6.4.2 AES ROM driver variables

The parameter channel_id is a combination of channel selection and DMA mux configuration and is defined as follows:

Bits[2:0]: Destination channel number (0 to 7).

Bits[11:8]: Destination peripheral control number (select 2 or 14. These are the AES out request lines).

Bits[13:12]: Destination DMA mux selection (use 3 if destination peripheral control number is 2, use 1 if destination peripheral control number is 14).

Bits[18:16]: Source channel number (0 to 7).

Bits[27:24]: Source peripheral control number (select 1 or 13, these are the AES in request lines).

Bits[29:28]: Source DMA mux selection (use 3 if destination peripheral control number is 1, use 1 if destination peripheral control number is 13).

Remark: Selecting the AES input and output DMA request lines in the channel_id structure configures the DMAMUX register (see [Section 10.4.5](#)) in the CREG block for AES.

6.4.3 AES API error codes

For general error codes, see [Chapter 48 “LPC18xx API General error codes”](#).

```
/* Security API related errors */  
ERR_SEC_AES_BASE = 0x00030000,  
/*0x00030001*/ ERR_SEC_AES_WRONG_CMD=ERR_SEC_AES_BASE+1,  
/*0x00030002*/ ERR_SEC_AES_NOT_SUPPORTED,  
/*0x00030003*/ ERR_SEC_AES_KEY_ALREADY_PROGRAMMED,  
/*0x00030004*/ ERR_SEC_AES_DMA_CHANNEL_CFG,  
/*0x00030005*/ ERR_SEC_AES_DMA_MUX_CFG,  
/*0x00030006*/ SEC_AES_DMA_BUSY,
```

6.5 Functional description

6.5.1 Using the AES API without DMA

Use the AES API functions as follows for data encryption/decryption without DMA:

1. Initialize the AES by calling `aes_Init`.
If the part is not a secure part, this routine returns an error.
2. Load the key:
 - `aes_LoadKey1` loads the secure key from OTP memory bank1.
 - `aes_LoadKey2` loads the non-secure key from OTP memory bank2.
 - `aes_LoadKeyRNG` loads a randomly generated key.
 - `aes_LoadKeySW` loads a key generated by the user code.
3. If using CBC encode or decode, load an initialization vector:
 - `aes_LoadIV_SW` loads a vector generated by the user code.
 - `aes_LoadIV_IC` loads a vector generated from the unique part id.
4. Define the AES mode by calling `aes_SetMode`.
Select encryption or decryption and the encoding algorithm (ECB or CBC).
5. Run the AES engine by calling `aes_Operate`.
The AES engine reads the data from a specified memory location and copies the encrypted or decrypted data to another memory location in 128-bit blocks.

6.5.2 Using the AES API with DMA

Use the AES API functions as follows for data encryption/decryption with DMA:

1. Initialize the AES by calling `aes_Init`.
If the part is not a secure part, this routine returns an error.
2. Load the key:
 - `aes_LoadKey1` loads the secure key from OTP memory bank1.
 - `aes_LoadKey2` loads the non-secure key from OTP memory bank2.
 - `aes_LoadKeyRNG` loads a randomly generated key.
 - `aes_LoadKeySW` loads a key generated by the user code.

3. If using CBC encode or decode, load an initialization vector:
 - `aes_LoadIV_SW` loads a vector generated by the user code.
 - `aes_LoadIV_IC` loads a vector generated from the unique part id.
4. Define the AES mode by calling `aes_SetMode`.
Select encryption or decryption and the encoding algorithm (ECB or CBC).
5. Set up the `channel_id` parameter with the DMA channel, the peripheral source and destination numbers, and the DMA input mux settings.
6. Configure the GPDMA by calling `aes_Config_DMA`.
7. Run the AES engine by calling `aes_Operate_DMA`.
The AES engine reads the data from a specified memory location and copies the encrypted or decrypted data to another memory location in 128-bit blocks.
8. Check whether the AES is done by calling `aes_Get_Status_DMA`.

6.5.3 AES Decryption

Secure boot authenticates and decrypts the boot image. See [Section 4.3.4](#).

AES decryption can also be used on non-image data to decrypt a frame of Cipher Text independent of other Cipher Text frames. This is useful when a random frame needs to be accessed.

6.5.4 Use of AES keys

The two hardware keys stored in OTP cannot be accessed by software and offer a high security level. Key1 is stored encrypted in OTP and offers the highest security level.

The software key is a software defined AES key. Since this key is visible to software, it is less secure than the hardware defined keys in OTP. However, the OTP can only store two keys whereas multiple keys can be stored in software.

The 128-bit AES initialization vector `iv` is used to randomize the encryption when the same data is encrypted multiple times. The init vector does not have to be secret. and is also used to decrypt the data. For the CMAC calculation, an AES initialization vector of `iv = 0` is used.

For the LPC18Sxx image, a user specific `iv` is used:

$$iv = \text{AES}^{-1}(\text{User Key}, 1)$$

6.5.5 Endianness

The AES engine is capable of processing 128-bit (16-byte) blocks per operation. To load/store an AES block, the 32-bit infrastructure is fully used. For convenience, the API interface uses byte order rather than word order. The API passes/obtains a pointer to an array of bytes, and the AES low-level driver type-casts the pointer to an unsigned 32-bit array. [Figure 25](#) shows 16-byte data AES encryption with a 16-byte key. For simplicity, data and key bytes are chosen in incrementing order starting from 00.

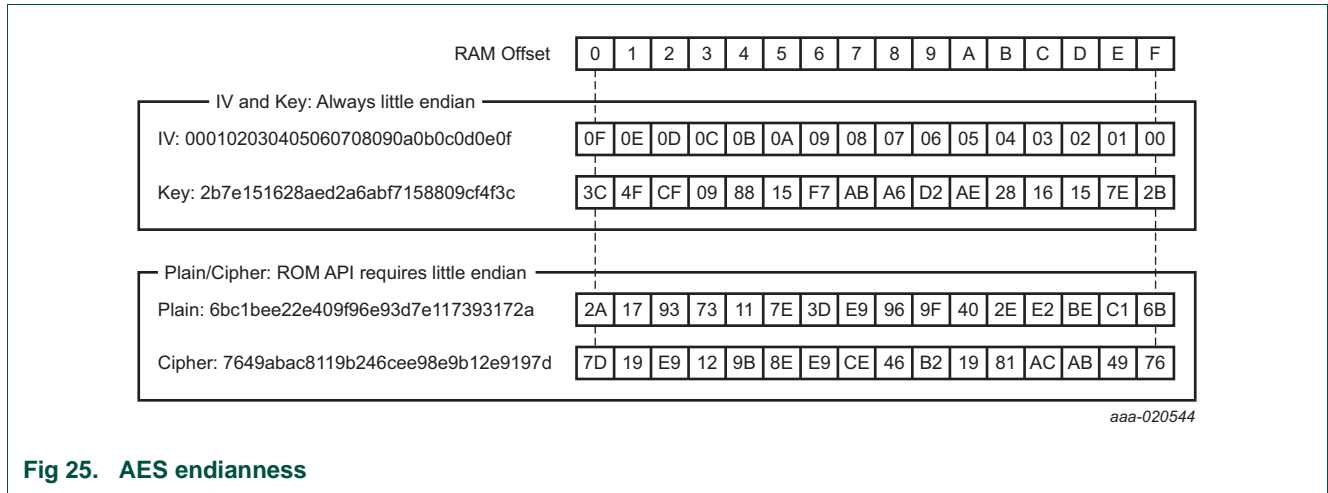

Fig 25. AES endianness

6.5.6 Storing AES keys in Deep power-down mode

In Deep power-down mode, all AES information is lost. After wake-up, the AES keys need to be reloaded. If you want to use the same RNG key as before entering Deep power-down mode, then you can store the RNG key in the backup registers at 0x4004 0000. Process the AES keys in the following order:

1. Generate a random number by calling the otp_GenRand() API.
2. Read the 128-bit random number at the following addresses:
 - Bits 31:0 at location 0x4004 5050
 - Bits 63:32 at location 0x4004 5054
 - Bits 95:64 at location 0x4004 5058
 - Bits 127:96 at location 0x4004 505C
3. Store this number in the RTC REGFILE registers.
4. Load this number in the AES engine using aes_LoadKeySW.

After every wake-up, perform the following operations:

1. Load the stored random number from the backup register.
2. Load this number in the AES engine using aes_LoadKeySW.

7.1 How to read this chapter

This chapter applies to all LPC18Sxx parts (secure parts) only.

Flash-based parts boot from on-chip flash by default (see [Chapter 5](#)), but other boot modes described in this chapter are also supported. The UART boot mode is only supported for flashless parts. The secure boot from USART3 is not supported for LPC18Sxx parts.

7.1.1 Determine the boot code version

For parts with on-chip flash, the boot code version can be determined using ISP or IAP calls. See [Table 40 “ISP Read Boot Code version number command”](#) and [Table 51 “IAP Read Boot Code version number command”](#).

For flashless parts, use ISP to read the boot code version number (see [Table 40](#)) or read memory location 0x1040 7FFC which encodes the boot code version as follows:

Value 0x000B 000n at location 0x1040 7FFC reads as boot code version 11.n.

7.2 Features

- Secure booting from an encrypted image.
- Cypher-based Message Authentication Code (CMAC) authentication on the boot image.
- Supports development mode for booting from a plain text image. Development mode is terminated by programming the AES key.

7.3 Functional description

7.3.1 Boot sources

The boot source is defined by the OTP or, if the OTP is blank, by the state of the boot pins in the same way as for non-secure parts. Secure parts with and without internal flash support the same boot sources as non-secure parts. See [Section 4.3](#).

7.3.2 Encryption and boot flow

All flashless secure parts can boot from a secure (encrypted) image with CMAC authentication. For parts with on-chip flash, the ISP mode must be enabled to select an external boot source with the encrypted image.

Remark: Any on-chip flash image containing valid user code can be protected by selecting from several CRP levels. See [Section 5.6 “Code Read Protection \(CRP\)”](#).

Secure booting generally involves the following steps:

1. On an external device, create a secure image from the plain-text image:

- a. Use a 128-bit key to encrypt the image using Cypher Block Chaining (CBC) encryption and an initialization vector of 0101010... (binary). After the first block of data, each following (plain-text) block is XORed with the previous encrypted block of data. For details, see [Section 7.3.4 “CMAC”](#).
 - b. Create a header using [Table 68 “Boot image header description”](#) with a dummy hash size. The actual hash size is calculated after encryption of the image and this header.
 - c. Encrypt the header using CBC and an initialization vector of 0.
 - d. Use CMAC to create a hash code and calculate the hash size of the combined encrypted header and image. See [Section 7.3.4 “CMAC”](#).
 - e. Update the header with the calculated hash size.
 - f. Encrypt header as before using CBC and an initialization vector of 0.
2. On the LPC18Sxx, program the encryption key into the OTP memory bank 1 using the API function `aes_ProgramKey1` (see [Table 67](#)).

Remark: The encryption key itself is scrambled in OTP memory bank 1 for added security.

3. Select boot mode. See [Section 4.3](#).
4. On parts with on-chip flash, JTAG access is not disabled. Therefore, set the appropriate CRP level in the flash memory to disable JTAG access.
On flashless parts, JTAG access is disabled automatically once the key is programmed in OTP memory bank 1.
5. Reset the LPC18xx, and the part boots securely from the specified boot source. See [Figure 27 “Boot flow for encrypted images \(flashless parts\)”](#).

Remark: To test the secure boot flow, you can create a secure image with a key of all zeros using the steps above and omitting programming the key into the OTP memory. The part then boots after reset using the zero-encrypted image.

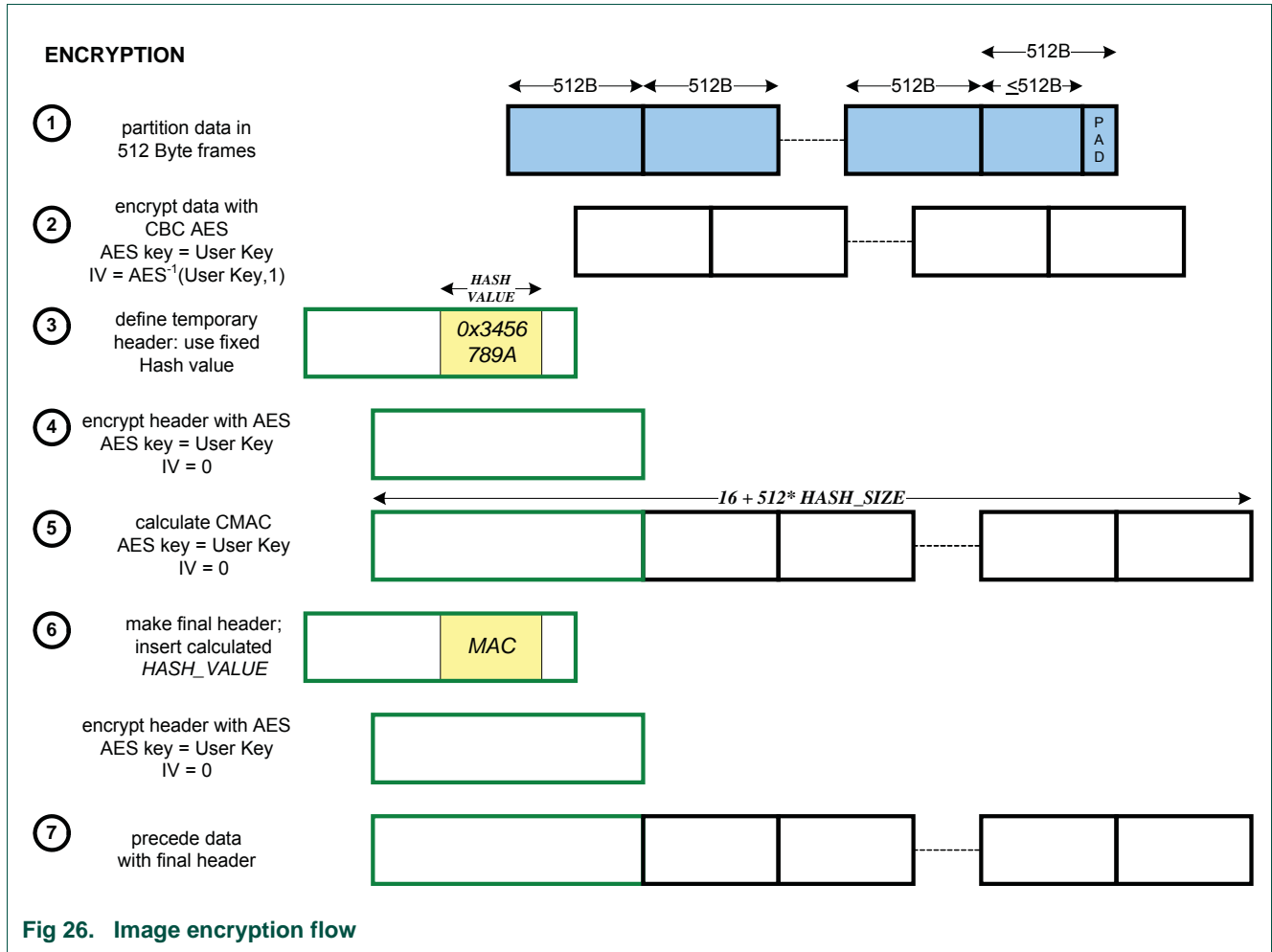
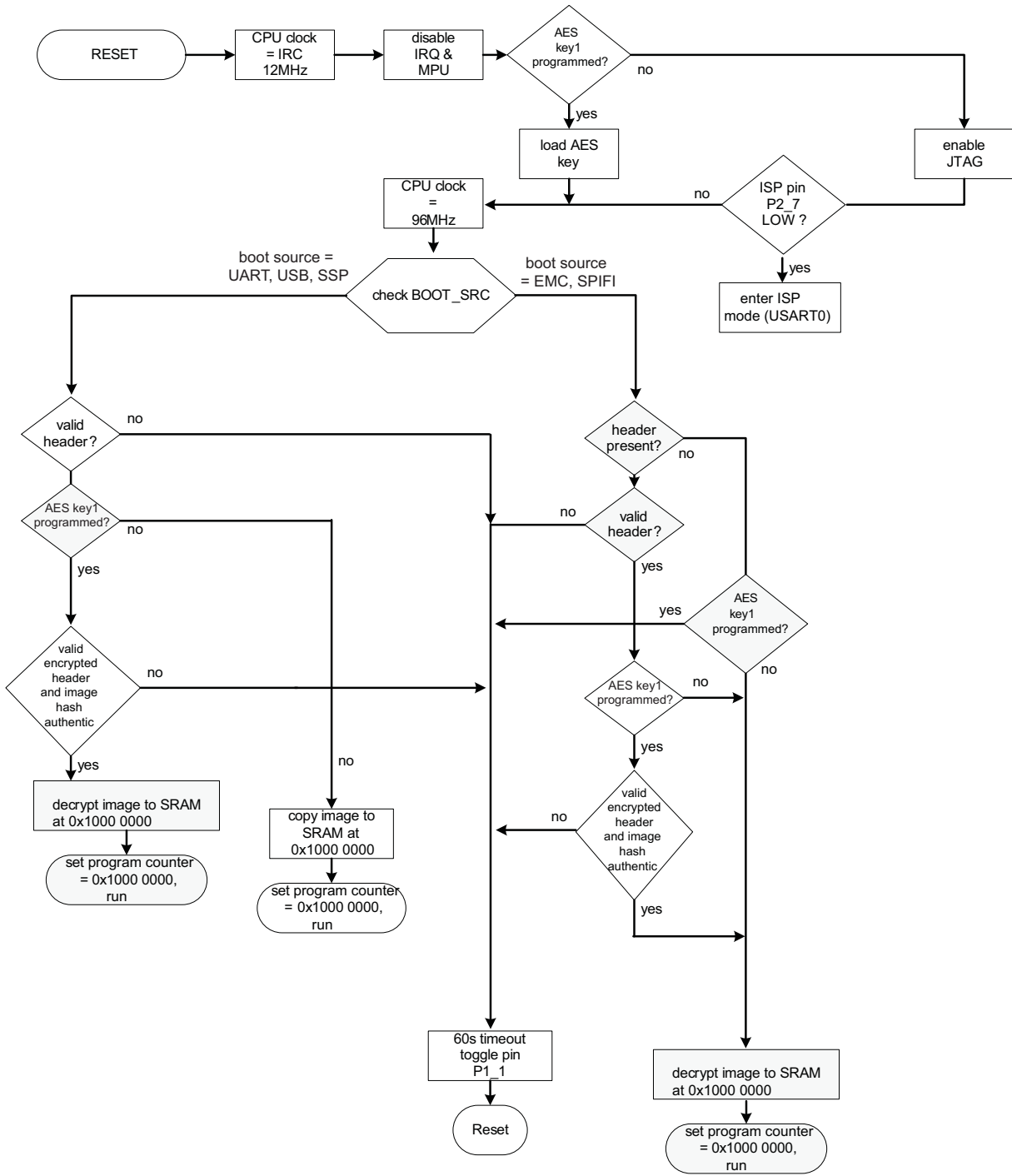

Fig 26. Image encryption flow



For parts with on-chip flash, the boot source is checked when the ISP pin is pulled LOW. All other flows are identical to flashless parts. See [Figure 11](#).

Fig 27. Boot flow for encrypted images (flashless parts)

7.3.2.1 Development mode

A special development mode allows booting from a plain text image. This development mode is active until the AES key1 has been programmed.

Once the AES key1 is programmed in the OTP, the development mode is terminated and JTAG access is automatically disabled for flashless parts.

7.3.3 Boot image header format

AES capable products with a programmed AES key1 will always boot from a secure image and use CMAC authentication. A secure image should always include a header.

The image must be preceded by a header that has the layout described in [Table 68](#). For encrypted images the header must be encrypted with the AES user key1 and initialization vector $iv = 0$. The user key is stored in the OTP (see [Table 9](#)).

Remark: All values except 0x1A in the AES_ACTIVE field in the encrypted header are considered valid. If the AES_ACTIVE field in the encrypted header has the value 0x1A (AES encryption not active), then the header should be changed such that the AES_ACTIVE field is not equal to 0x1A. A change in one of the AES_CONTROL bits will produce an alternative value. The correct mechanism when creating an encrypted header is to try every possible value in AES_CONTROL until the encrypted version does not contain the value 0x1A in the AES_ACTIVE field.

Table 68. Boot image header description

Address	Name	Description	size [bits]
5:0	AES_ACTIVE ^[1]	AES encryption active 0x25 (100101): AES encryption active 0x1A (011010): AES encryption not active all other values: invalid image	6
7:6	HASH_ACTIVE ^[1]	Indicates whether a hash is used: 00: CMAC hash is used, value is HASH_VALUE 01: reserved 10: reserved 11: no hash is used	2
15:8	AES_CONTROL	When AES encryption is active, these bits can be set to a value such that the AES_ACTIVE field after AES encryption is not equal to the value 0x1A (AES encryption not active).	2
31:16	HASH_SIZE ^[3]	Size of the part of the image over which the hash value is calculated in number of 512 Byte frames. Also size of the image copied to internal SRAM. Hash size = $16^{\text{[2]}} + \text{HASH_SIZE} \times 512 \text{ Byte}$.	16
95:32	HASH_VALUE	CMAC hash value calculated over the first bytes of the image (starting right from the header) as indicated by HASH_SIZE. The value is truncated to the 64 MSB.	64
127:96	RESERVED	11...11 (binary)	32

- [1] Can only be active if device is AES capable, else is considered an invalid image.
- [2] 16 extra bytes are required for the header bytes.
- [3] The image size should be set to no more than the size of the SRAM located at 0x1000 0000.

7.3.4 CMAC

The CMAC algorithm is used to calculate a tag which is used for image authentication. The tag is stored in the header field HASH_VALUE.

The authentication process works as follows:

1. Use the CMAC algorithm to generate the 128-bit tag. Truncate the tag to 64 MSB and insert this truncated tag in the header.
2. At boot time the tag is recalculated. Authentication passes when the calculated tag is equal to the received tag in the image header.

To generate an I-bit CMAC tag T of message M using a 128-bit block cipher AES and secret key K, the CMAC tag generation process works as follows:

1. Generate sub key K_1 :
 - Calculate a temporary value $K_0 = \text{AES}_K(0)$.
 - If $\text{msb}(K_0) = 0$ then $K_1 = (K_0 \ll 1)$ else $K_1 = (K_0 \ll 1) \oplus 0x87$
2. Divide message into 128-bit blocks $M = M_1 \parallel \dots \parallel M_{n-1} \parallel M_n^*$, where $M_1 \dots M_{n-1}$ are complete blocks.
3. The last block, M_n^* , should be padded to be a complete block and then $M_n = K_1 \oplus M_n^*$.
4. Let $c_0 = 00\dots0$.
5. For $i = 1, \dots, n$, calculate $c_i = \text{AES}_K(c_{i-1} \oplus M_i)$.
6. Output $T = \text{msb}_I(c_n)$.

The first message block is the header. Since the CMAC tag is stored in the header field HASH_VALUE, and this tag is not yet known until after CMAC calculation, a temporary header with a dummy tag value of 0x3456789A is used during CMAC calculation. This dummy value should be replaced by the calculated tag value in the final header field HASH_VALUE.

For LPC18xx the chosen CMAC parameters are: encryption key $K = \text{User Key}$ (AES key1, same as used for decryption) and tag length $I = 64$. Data is processed in little endian mode. This means that the first byte read from the image is integrated into the AES codeword as least significant byte. The 16th byte read from the image is the most significant byte of the first AES codeword.

CMAC is calculated over the header and encrypted image.

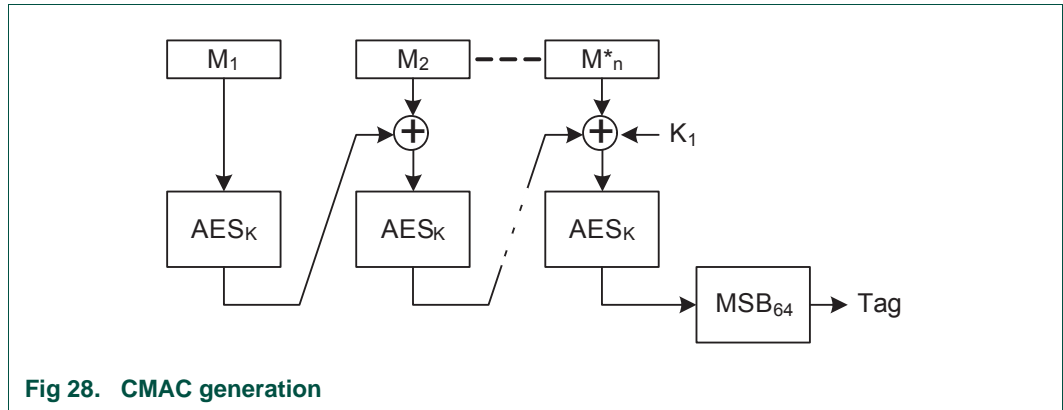

Fig 28. CMAC generation

7.3.5 Boot process timing

The following parameters describe the timing of the boot process:

Table 69. Typical boot process timing parameters

Parameter	Description	Value
t_a	Check boot selection pins	< 1.25 μ s
t_b	Initialize device	250 μ s ^[1] ; 180 μ s ^[2] ; 200 μ s ^[3]
t_c	Copy image to embedded SRAM If part is executing from external flash with no copy	< 0.3 μ s
	If the image is encrypted or must be copied	< 1 μ s to 10000 μ s depending on the size of the image and the speed of the boot memory

[1] For flashless parts LPC1850/30/20/10.

[2] For parts with on-chip flash; booting from flash.

[3] For parts with on-chip flash; booting from an external source.

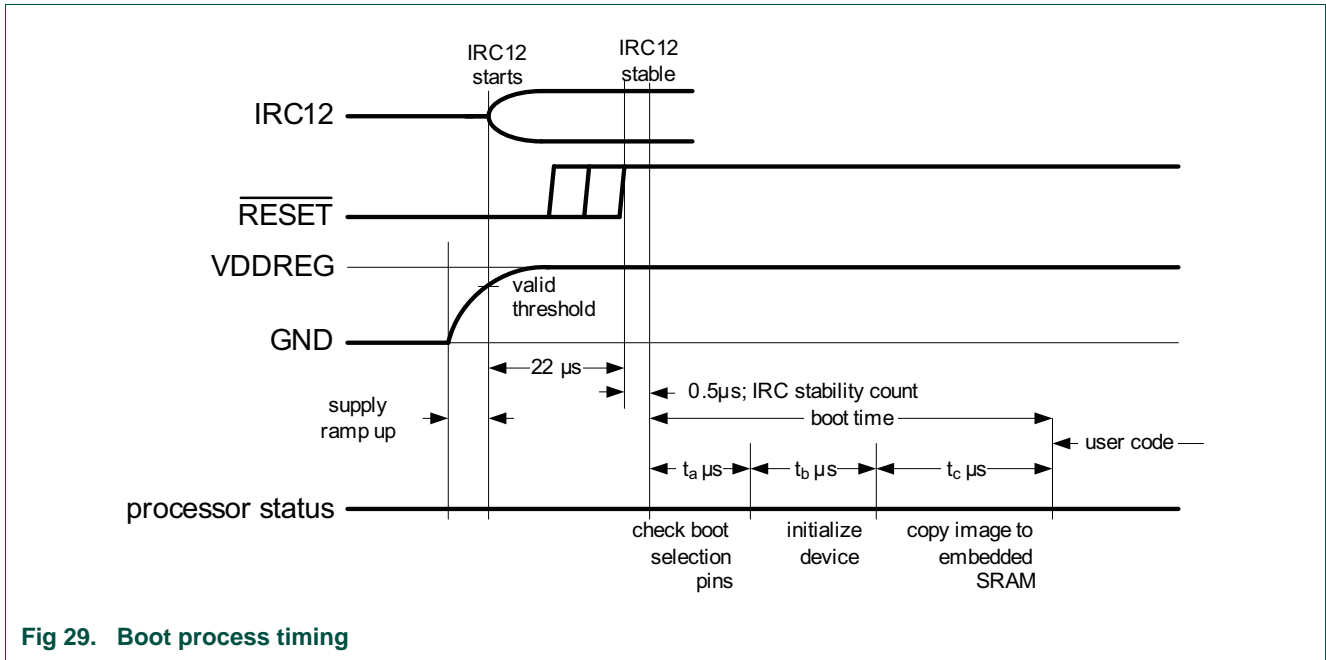

Fig 29. Boot process timing

8.1 How to read this chapter

The NVIC interrupt sources vary for different parts.

- Ethernet interrupt: available only on LPC185x/3x.
- USB0 interrupt: available only on LPC185x/3x/2x.
- USB1 interrupt: available only on LPC185x/3x.
- Flash/EEPROM interrupts: available on parts with on-chip flash only.

8.2 Basic configuration

The NVIC is part of the ARM Cortex-M3 core.

8.3 Features

- Nested Vectored Interrupt Controller is an integral part of the ARM Cortex-M3.
- Tightly coupled interrupt controller provides low interrupt latency.
- Controls system exceptions and peripheral interrupts.
- On the LPC18xx, the NVIC supports 53 vectored interrupts.
- Eight programmable interrupt priority levels with hardware priority level masking.
- Relocatable vector table.
- Non-Maskable Interrupt.
- Software interrupt generation.

8.4 General description

The Nested Vectored Interrupt Controller (NVIC) is an integral part of the Cortex-M3. The tight coupling to the CPU allows for low interrupt latency and efficient processing of late arriving interrupts.

Refer to the Cortex-M3 User Guide for details of NVIC operation.

8.5 Pin description

Table 70. NVIC pin description

Function	Direction	Description
NMI	I	External Non-Maskable Interrupt (NMI) input

8.6 Interrupt sources

[Table 71](#) lists the interrupt sources for each peripheral function. Each peripheral device may have one or more interrupt lines to the Vectored Interrupt Controller. Each line may represent more than one interrupt source, as noted.

Exception numbers relate to where entries are stored in the exception vector table. Interrupt numbers are used in some other contexts, such as software interrupts.

In addition, the NVIC handles the Non-Maskable Interrupt (NMI). In order for NMI to operate from an external signal, the NMI function must be connected to the related device pin (P4_0 or PE_4). When connected, a logic one on the pin will cause the NMI to be processed. For details, refer to the Cortex-M3 User Guide.

Table 71. Connection of interrupt sources to the NVIC

Interrupt ID	Exception Number	Vector Offset	Function	Flag(s)
0	16	0x40	DAC	-
1	17	0x44	-	Reserved
2	18	0x48	DMA	-
3	19	0x4C	-	Reserved
4	20	0x50	FLASHEEPROM	ORed flash bank A, flash bank B, EEPROM interrupt
5	21	0x54	ETHERNET	Ethernet interrupt
6	22	0x58	SDIO	SD/MMC interrupt
7	23	0x5C	LCD	-
8	24	0x60	USB0	OTG interrupt
9	25	0x64	USB1	USB1 AHB_NEED_CLK
10	26	0x68	SCT	SCT combined interrupt
11	27	0x6C	RITIMER	-
12	28	0x70	TIMER0	-
13	29	0x74	TIMER1	-
14	30	0x78	TIMER2	-
15	31	0x7C	TIMER3	-
16	32	0x80	MCPWM	Motor control PWM
17	33	0x84	ADC0	-
18	34	0x88	I2C0	-
19	35	0x8C	I2C1	-
20	36	0x90	-	Reserved
21	37	0x94	ADC1	-
22	38	0x98	SSP0	-
23	39	0x9C	SSP1	-
24	40	0xA0	USART0	-
25	41	0xA4	UART1	UART and modem interrupt
26	42	0xA8	USART2	-
27	43	0xAC	USART3	USART and IrDA interrupt

Table 71. Connection of interrupt sources to the NVIC

Interrupt ID	Exception Number	Vector Offset	Function	Flag(s)
28	44	0xB0	I2S0	-
29	45	0xB4	I2S1	-
30	46	0xB8	-	Reserved
31	47	0xBC	-	Reserved
32	48	0xC0	PIN_INT0	GPIO pin interrupt 0
33	49	0xC4	PIN_INT1	GPIO pin interrupt 1
34	50	0xC8	PIN_INT2	GPIO pin interrupt 2
35	51	0xCC	PIN_INT3	GPIO pin interrupt 3
36	52	0xD0	PIN_INT4	GPIO pin interrupt 4
37	53	0xD4	PIN_INT5	GPIO pin interrupt 5
38	54	0xD8	PIN_INT6	GPIO pin interrupt 6
39	55	0xDC	PIN_INT7	GPIO pin interrupt 7
40	56	0xE0	GINT0	GPIO global interrupt 0
41	57	0xE4	GINT1	GPIO global interrupt 1
42	58	0xE8	Event router	Combined interrupt from the event router sources
43	59	0xEC	C_CAN1 interrupt	-
44	60	0xF0	Reserved	-
45	61	0xF4	Reserved	-
46	62	0xF8	ATIMER	Alarm timer interrupt
47	63	0xFC	RTC	Combined RTC and event router/monitor interrupt
48	64	0x100	Reserved	-
49	65	0x104	WWDT	-
50	66	0x108	Reserved	-
51	67	0x10C	C_CAN0	-
52	68	0x110	QEI	-

8.7 Register description

The following table summarizes the registers in the NVIC as implemented in the LPC18xx. The Cortex-M3 User Guide provides a functional description of the NVIC registers.

Table 72. Register overview: NVIC (base address 0xE000 E000)

Name	Access	Address offset	Description	Reset value
ISER0	RW	0x100	Interrupt Set-Enable Register 0. This register allows enabling interrupts and reading back the interrupt enables for specific peripheral functions.	0
ISER1	RW	0x104	Interrupt Set-Enable Register 1. This register allows enabling interrupts and reading back the interrupt enables for specific peripheral functions.	0
ICER0	RW	0x180	Interrupt Clear-Enable Register 0. This register allows disabling interrupts and reading back the interrupt enables for specific peripheral functions.	0

Table 72. Register overview: NVIC (base address 0xE000 E000) ...continued

Name	Access	Address offset	Description	Reset value
ICER1	RW	0x184	Interrupt Clear-Enable Register 1. This register allows disabling interrupts and reading back the interrupt enables for specific peripheral functions.	0
ISPR0	RW	0x200	Interrupt Set-Pending Register 0. This register allows changing the interrupt state to pending and reading back the interrupt pending state for specific peripheral functions.	0
ISPR1	RW	0x204	Interrupt Set-Pending Register 1. This register allows changing the interrupt state to pending and reading back the interrupt pending state for specific peripheral functions.	0
ICPR0	RW	0x280	Interrupt Clear-Pending Register 0. This register allows changing the interrupt state to not pending and reading back the interrupt pending state for specific peripheral functions.	0
ICPR1	RW	0x284	Interrupt Clear-Pending Register 1. This register allows changing the interrupt state to not pending and reading back the interrupt pending state for specific peripheral functions.	0
IABR0	RO	0x300	Interrupt Active Bit Register 0. This register allows reading the current interrupt active state for specific peripheral functions.	0
IABR1	RO	0x304	Interrupt Active Bit Register 1. This register allows reading the current interrupt active state for specific peripheral functions.	0
IPR0	RW	0x400	Interrupt Priority Registers 0. This register allows assigning a priority to each interrupt. Each register contains the 3-bit priority fields for 4 interrupts.	0
IPR1	RW	0x404	Interrupt Priority Registers 1. This register allows assigning a priority to each interrupt. Each register contains the 3-bit priority fields for 4 interrupts.	0
IPR2	RW	0x408	Interrupt Priority Registers 2. This register allows assigning a priority to each interrupt. Each register contains the 3-bit priority fields for 4 interrupts.	0
IPR3	RW	0x40C	Interrupt Priority Registers 3. This register allows assigning a priority to each interrupt. Each register contains the 3-bit priority fields for 4 interrupts.	0
IPR4	RW	0x410	Interrupt Priority Registers 4. This register allows assigning a priority to each interrupt. Each register contains the 3-bit priority fields for 4 interrupts.	0
IPR5	RW	0x414	Interrupt Priority Registers 5. This register allows assigning a priority to each interrupt. Each register contains the 3-bit priority fields for 4 interrupts.	0
IPR6	RW	0x418	Interrupt Priority Registers 6. This register allows assigning a priority to each interrupt. Each register contains the 3-bit priority fields for 4 interrupts.	0
IPR7	RW	0x41C	Interrupt Priority Registers 7. This register allows assigning a priority to each interrupt. Each register contains the 3-bit priority fields for 4 interrupts.	0
STIR	WO	0xF00	Software Trigger Interrupt Register. This register allows software to generate an interrupt.	0

9.1 How to read this chapter

The event router sources vary for different parts.

- Ethernet: available only on LPC185x/3x.
- USB0: available only on LPC185x/3x/2x.
- USB1: available only on LPC185x/3x.

Remark: The event monitor/recorder interrupt from the RTC block is implemented in parts with on-chip flash only.

9.2 Basic configuration

- See [Table 73](#) for clocking.
- The event router is connected to interrupt #42 in the NVIC (see [Table 71](#)).
- The CREG0 register configures the WAKEUP0/1 pins as inputs to the event router or as outputs which monitor the output of the event router (see [Table 88](#)).
- In order to detect an event connected to any of the peripheral interrupts, set the corresponding bit to HIGH in the HILO register (the default setting of this register is LOW).
- When using events #4 and #5, activate the 32 kHz oscillator in the CREG0 register ([Table 88](#)).

Table 73. Event router clocking and power control

	Base clock	Branch clock	Operating frequency
Clock to event router	BASE_M3_CLK	CLK_M3_BUS	up to 180 MHz

9.3 General description

The event router is used to process wake-up events such as certain interrupts and external or internal inputs for wake-up from any of the Power-down modes (Sleep, Deep-sleep, Power-down, and Deep power-down modes).

In Deep-sleep, Power-down, or Deep power-down mode, only events on one of the four WAKEUP pins and the RTC and alarm timer events, if the 32 kHz oscillator is running, are active (see [Table 74](#)).

All events can wake up the part from Sleep mode. However, the RTC and alarm timer events require that the 32 kHz oscillator is running.

The event router has multiple event inputs from various peripherals. When the proper edge detection is set in the EDGE configuration register, the event router can wake up the part or can raise an interrupt in the NVIC.

Each event input to the event router can be configured to trigger an output signal on rising or falling edges or on HIGH or LOW levels. The event router combines all events to an output signal which is used as follows:

- Create an interrupt if the event router interrupt is enabled in the NVIC.
- Send an interrupt to the NVIC to wake up from WFI induced Sleep mode or Deep-sleep mode.
- Wake up from WFE induced Sleep or Deep-sleep mode.
- Send a wake-up signal to the power management unit to wake up from Deep-sleep, Power-down, and Deep power-down modes.
- Send a wake-up signal to CCU1 and CCU2 for turning on wake-up enabled branch clocks (see [Section 13.5.3](#)).

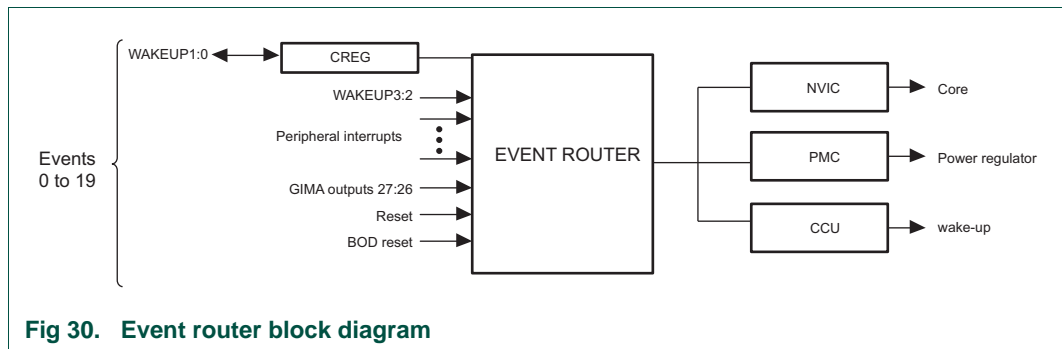

Fig 30. Event router block diagram

9.4 Event router inputs

Table 74. Event router inputs

Event #	Source	Description
0	WAKEUP0 pin	WAKEUP0 pin. Always active. Use for wake-up from Deep power-down and all other Power-down modes.
1	WAKEUP1 pin	WAKEUP1 pin. Always active. Use for wake-up from Deep power-down and all other Power-down modes.
2	WAKEUP2 pin	WAKEUP2 pin. Always active. Use for wake-up from Deep power-down and all other Power-down modes.
3	WAKEUP3 pin	WAKEUP3 pin. Always active. Use for wake-up from Deep power-down and all other Power-down modes.
4	Alarm timer peripheral	Alarm timer interrupt. Active whenever the 32 kHz oscillator is running.
5	RTC peripheral	RTC and event recorder/monitor interrupt (see Section 9.2). Active whenever the 32 kHz oscillator is running.
6	BOD trip level 1	BOD interrupt. Not active in Deep-sleep, Power-down, and Deep power-down mode. Use for wake-up from Sleep mode.
7	WWDT peripheral	WWDT interrupt. Not active in Deep-sleep, Power-down, and Deep power-down mode. Use for wake-up from Sleep mode.

Table 74. Event router inputs

Event #	Source	Description
8	Ethernet peripheral	Wake-up packet indicator. Not active in Deep-sleep, Power-down, and Deep power-down mode. Use for wake-up from Sleep mode.
9	USB0 peripheral	Wake-up request signal. Not active in power-down and deep power-down mode. Use for wake-up from sleep and deep-sleep mode. See Section 23.12.4 .
10	USB1 peripheral	USB1 AHB_NEED_CLK signal. Not active in power-down and deep power-down mode. Use for wake up from sleep and deep-sleep mode. See Section 24.7.1 .
11	SD/MMC peripheral	SD/MMC interrupt. Not active in Deep-sleep, Power-down, and Deep power-down mode. Use for wake-up from Sleep mode.
12	C_CAN0/1 peripherals	ORed C_CAN0 and C_CAN1 interrupt. Not active in Deep-sleep, Power-down, and Deep power-down mode. Use for wake-up from Sleep mode.
13	GIMA output 25	Output 2 of the combined timer (ORed output of SCT output 2 and the match channel 2 of timer 0). See Table 192 . Not active in Deep-sleep, Power-down, and Deep power-down mode. Use for wake-up from Sleep mode.
14	GIMA output 26	Output 6 of the combined timer (ORed output of SCT output 2 and the match channel 2 of timer 1). See Table 192 . Not active in Deep-sleep, Power-down, and Deep power-down mode. Use for wake-up from Sleep mode.
15	QEI peripheral	QEI interrupt. Not active in Deep-sleep, Power-down, and Deep power-down mode. Use for wake-up from Sleep mode.
16	GIMA output 27	Output 14 of the combined timer (ORed output of SCT output 14 and the match channel 2 of timer 3). See Table 192 . Not active in Deep-sleep, Power-down, and Deep power-down mode. Use for wake-up from Sleep mode.
17	-	Reserved
18	-	Reserved
19	Reset	Reset event on pin RESET . Always functional. Active LOW.
20	BOD reset	Voltage on $V_{DD(REG)(3V3)}$ falls below the BOD reset level. Active HIGH.
21	DPD	Wake-up from Deep power-down mode. At this time the part is reset. Active HIGH.

9.5 Pin description

Table 75. Event router pin description

Pin	Direction	Description
WAKEUP0/1	I/O	External wake-up input; can raise an event router interrupt and can cause wake-up from any of the power-down modes. These pins can be configured to monitor the event router output through the CREG0 register (Table 88).
WAKEUP2/3	I	External wake-up input; can raise an event router interrupt and can cause wake-up from any of the power-down modes.

9.6 Register description

Table 76. Register overview: Event router (base address 0x4004 4000)

Name	Access	Address offset	Description	Reset Value	Reference
HILO	R/W	0x000	Level configuration register	0x000	Table 77
EDGE	R/W	0x004	Edge configuration	0x000	Table 79
-	-	0x008 - 0xFD4	Reserved	-	-
CLR_EN	W	0xFD8	Clear event enable register	0x0	Table 80
SET_EN	W	0xFDC	Set event enable register	0x0	Table 81
STATUS	R	0xFE0	Event Status register	0x03FD FFFF	Table 82
ENABLE	R	0xFE4	Event Enable register	0x0	Table 83
CLR_STAT	W	0xFE8	Clear event status register	0x0	Table 84
SET_STAT	W	0xFEC	Set event status register	0x0	Table 85

9.6.1 Level configuration register

This register works in combination with the edge configuration register EDGE (see [Table 79](#)) to configure the level and edge detection for each input to the event router.

Table 77. Level configuration register (HILO - address 0x4004 4000) bit description

Bit	Symbol	Value	Description	Reset value
0	WAKEUP0_L		Level detect mode for WAKEUP0 event.	0
		0	Detect LOW level on the WAKEUP0 pin if bit 0 in the EDGE register is 0. Detect falling edge if bit 0 in the EDGE register is 1.	
		1	Detect HIGH level on the WAKEUP0 pin if bit 0 in the EDGE register is 0. Detect rising edge if bit 0 in the EDGE register is 1.	

Table 77. Level configuration register (HILO - address 0x4004 4000) bit description

Bit	Symbol	Value	Description	Reset value
1	WAKEUP1_L		Level detect mode for WAKEUP1 event. The corresponding bit in the EDGE register must be 0.	0
		0	Detect LOW level on the WAKEUP1 pin if bit 1 in the EDGE register is 0.	
		1	Detect HIGH level on the WAKEUP1 pin if bit 1 in the EDGE register is 0. Detect rising edge if bit 1 in the EDGE register is 1.	
2	WAKEUP2_L		Level detect mode for WAKEUP2 event.	0
		0	Detect LOW level on the WAKEUP2 pin if bit 2 in the EDGE register is 0. Detect falling edge if bit 2 in the EDGE register is 1.	
		1	Detect HIGH level on the WAKEUP2 pin if bit 2 in the EDGE register is 0. Detect rising edge if bit 2 in the EDGE register is 1.	
3	WAKEUP3_L		Level detect mode for WAKEUP3 event.	0
		0	Detect LOW level on the WAKEUP3 pin if bit 3 in the EDGE register is 0. Detect falling edge if bit 3 in the EDGE register is 1.	
		1	Detect HIGH level on the WAKEUP3 pin if bit 3 in the EDGE register is 0. Detect rising edge if bit 3 in the EDGE register is 1.	
4	ATIMER_L		Level detect mode for alarm timer event.	0
		0	Detect LOW level of the alarm timer interrupt if bit 4 in the EDGE register is 0. Detect falling edge if bit 4 in the EDGE register is 1.	
		1	Detect HIGH level of the alarm timer interrupt if bit 4 in the EDGE register is 0. Detect rising edge if bit 4 in the EDGE register is 1.	
5	RTC_L		Level detect mode for RTC event.	0
		0	Detect LOW level of the RTC interrupt if bit 5 in the EDGE register is 0. Detect falling edge if bit 5 in the EDGE register is 1.	
		1	Detect HIGH level of the RTC interrupt if bit 5 in the EDGE register is 0. Detect rising edge if bit 5 in the EDGE register is 1.	
6	BOD_L		Level detect mode for BOD event.	0
		0	Detect LOW level of the BOD interrupt if bit 6 in the EDGE register is 0. Detect falling edge if bit 6 in the EDGE register is 1.	
		1	Detect HIGH level of the BOD interrupt if bit 6 in the EDGE register is 0. Detect rising edge if bit 6 in the EDGE register is 1.	

Table 77. Level configuration register (HILO - address 0x4004 4000) bit description

Bit	Symbol	Value	Description	Reset value
7	WWDT_L		Level detect mode for WWDT event.	0
		0	Detect LOW level of the WWDT interrupt if bit 7 in the EDGE register is 0. Detect falling edge if bit 7 in the EDGE register is 1.	
		1	Detect HIGH level of the WWDT interrupt if bit 7 in the EDGE register is 0. Detect rising edge if bit 7 in the EDGE register is 1.	
8	ETH_L		Level detect mode for Ethernet event	0
		0	Detect LOW level of the Ethernet interrupt if bit 8 in the EDGE register is 0. Detect falling edge if bit 8 in the EDGE register is 1.	
		1	Detect HIGH level of the Ethernet interrupt if bit 8 in the EDGE register is 0. Detect rising edge if bit 8 in the EDGE register is 1.	
9	USB0_L		Level detect mode for USB0 event	0
		0	Detect LOW level of the USB0 interrupt if bit 9 in the EDGE register is 0. Detect falling edge if bit 9 in the EDGE register is 1.	
		1	Detect HIGH level of the USB0 interrupt if bit 9 in the EDGE register is 0. Detect rising edge if bit 9 in the EDGE register is 1.	
10	USB1_L		Level detect mode for USB1 event	0
		0	Detect LOW level of the USB1 interrupt if bit 10 in the EDGE register is 0. Detect falling edge if bit 10 in the EDGE register is 1.	
		1	Detect HIGH level of the USB1 interrupt if bit 10 in the EDGE register is 0. Detect rising edge if bit 10 in the EDGE register is 1.	
11	SDMMC_L		Level detect mode for SD/MMC event	0
		0	Detect LOW level of the SD/MMC interrupt if bit 11 in the EDGE register is 0. Detect falling edge if bit 11 in the EDGE register is 1.	
		1	Detect HIGH level of the SD/MMC interrupt if bit 11 in the EDGE register is 0. Detect rising edge if bit 11 in the EDGE register is 1.	
12	CAN_L		Level detect mode for C_CAN event.	0
		0	Detect LOW level of the combined C_CAN interrupt if bit 12 in the EDGE register is 0. Detect falling edge if bit 12 in the EDGE register is 1.	
		1	Detect HIGH level of the combined C_CAN interrupt if bit 12 in the EDGE register is 0. Detect rising edge if bit 12 in the EDGE register is 1.	

Table 77. Level configuration register (HILO - address 0x4004 4000) bit description

Bit	Symbol	Value	Description	Reset value
13	TIM2_L		Level detect mode for combined timer output 2 event.	0
		0	Detect LOW level GIMA output 25 if bit 13 in the EDGE register is 0. Detect falling edge if bit 13 in the EDGE register is 1.	
		1	Detect HIGH level GIMA output 25 if bit 13 in the EDGE register is 0. Detect rising edge if bit 13 in the EDGE register is 1.	
14	TIM6_L		Level detect mode for combined timer output 6 event.	0
		0	Detect LOW level of GIMA output 26 if bit 14 in the EDGE register is 0. Detect falling edge if bit 14 in the EDGE register is 1.	
		1	Detect HIGH level of GIMA output 26 if bit 14 in the EDGE register is 0. Detect rising edge if bit 14 in the EDGE register is 1.	
15	QEI_L		Level detect mode for QEI event.	0
		0	Detect LOW level of the QEI interrupt if bit 15 in the EDGE register is 0. Detect falling edge if bit 15 in the EDGE register is 1.	
		1	Detect HIGH level of the QEI interrupt if bit 15 in the EDGE register is 0. Detect rising edge if bit 15 in the EDGE register is 1.	
16	TIM14_L		Level detect mode for combined timer output 14 event.	0
		0	Detect LOW level of GIMA output 27 if bit 16 in the EDGE register is 0. Detect falling edge if bit 16 in the EDGE register is 1.	
		1	Detect HIGH level of GIMA output 27 if bit 16 in the EDGE register is 0. Detect rising edge if bit 16 in the EDGE register is 1.	
18:17	-	-	Reserved.	
19	RESET_L		Level detect mode for Reset	0
		0	Detect LOW level if bit 19 in the EDGE register is 0. Detect falling edge if bit 19 in the EDGE register is 1.	
		1	Detect HIGH level if bit 19 in the EDGE register is 0. Detect rising edge if bit 19 in the EDGE register is 1.	
20	BODRESET_L		Level detect mode for BOD Reset	0
		0	Detect LOW level if bit 20 in the EDGE register is 0. Detect falling edge if bit 20 in the EDGE register is 1.	
		1	Detect HIGH level if bit 20 in the EDGE register is 0. Detect rising edge if bit 20 in the EDGE register is 1.	
21	DPDRESET_L		Level detect mode for Deep power-down Reset	0
		0	Detect LOW level if bit 21 in the EDGE register is 0. Detect falling edge if bit 21 in the EDGE register is 1.	
		1	Detect HIGH level if bit 21 in the EDGE register is 0. Detect rising edge if bit 21 in the EDGE register is 1.	
31:22	-	-	Reserved.	

9.6.2 Edge configuration register

This register works in combination with the level configuration register HILO (see [Table 77](#)) to configure the level or edge detection for each input to the event router.

The EDGE configuration register determines whether the event router responds to a level change (EDGE_n=1), or a constant level (EDGE_n=0). The HILO_n bit determines a response to a rising edge (HILO_n=1) or a falling edge (HILO_n=0).

Table 78. EDGE and HILO combined register settings

HILO bit n	EDGE bit n	Description
0	0	Detect LOW level
0	1	Detect falling edge
1	0	Detect HIGH level
1	1	Detect rising edge

When a HIGH level detect is active, the event router status bits cannot be cleared until the signal is LOW. When a rising edge detect is active, the event router status bit can be cleared right after the event has occurred.

Table 79. Edge configuration register (EDGE - address 0x4004 4004) bit description

Bit	Symbol	Value	Description	Reset value
0	WAKEUP0_E		Edge detect mode for WAKEUP0 event. The corresponding bit in the EDGE register must be 0.	0
		0	Level detect.	
		1	Edge detect of WAKEUP0 pin. Detect falling edge if bit 0 in the HILO register is 0. Detect rising edge if bit 0 in the HILO register is 1.	
1	WAKEUP1_E		Edge/level detect mode for WAKEUP1 event. The corresponding bit in the EDGE register must be 0.	0
		0	Level detect.	
		1	Edge detect of WAKEUP1 pin. Detect falling edge if bit 1 in the HILO register is 0. Detect rising edge if bit 1 in the HILO register is 1.	
2	WAKEUP2_E		Edge/level detect mode for WAKEUP2 event. The corresponding bit in the EDGE register must be 0.	0
		0	Level detect.	
		1	Edge detect of WAKEUP2 pin. Detect falling edge if bit 2 in the HILO register is 0. Detect rising edge if bit 2 in the HILO register is 1.	
3	WAKEUP3_E		Edge/level detect mode for WAKEUP3 event. The corresponding bit in the EDGE register must be 0.	0
		0	Level detect.	
		1	Edge detect of WAKEUP3 pin. Detect falling edge if bit 30 in the HILO register is 0. Detect rising edge if bit 3 in the HILO register is 1.	

Table 79. Edge configuration register (EDGE - address 0x4004 4004) bit description

Bit	Symbol	Value	Description	Reset value
4	ATIMER_E		Edge/level detect mode for alarm timer event. The corresponding bit in the EDGE register must be 0.	0
		0	Level detect.	
		1	Edge detect of the alarm timer interrupt. Detect falling edge if bit 4 in the HILO register is 0. Detect rising edge if bit 4 in the HILO register is 1.	
5	RTC_E		Edge/level detect mode for RTC event. The corresponding bit in the EDGE register must be 0.	0
		0	Level detect.	
		1	Edge detect of the RTC interrupt. Detect falling edge if bit 5 in the HILO register is 0. Detect rising edge if bit 5 in the HILO register is 1.	
6	BOD_E		Edge/level detect mode for BOD event. The corresponding bit in the EDGE register must be 0.	0
		0	Level detect.	
		1	Edge detect of the BOD interrupt. Detect falling edge if bit 6 in the HILO register is 0. Detect rising edge if bit 6 in the HILO register is 1.	
7	WWDT_E		Edge/level detect mode for WWDTD event. The corresponding bit in the EDGE register must be 0.	0
		0	Level detect.	
		1	Edge detect of the WWDT interrupt. Detect falling edge if bit 7 in the HILO register is 0. Detect rising edge if bit 7 in the HILO register is 1.	
8	ETH_E		Edge/level detect mode for ethernet event. The corresponding bit in the EDGE register must be 0.	0
		0	Level detect.	
		1	Edge detect of the Ethernet interrupt. Detect falling edge if bit 8 in the HILO register is 0. Detect rising edge if bit 8 in the HILO register is 1.	
9	USB0_E		Edge/level detect mode for USB0 event. The corresponding bit in the EDGE register must be 0.	0
		0	Level detect.	
		1	Edge detect of the USB0 event. Detect falling edge if bit 9 in the HILO register is 0. Detect rising edge if bit 9 in the HILO register is 1.	
10	USB1_E		Edge/level detect mode for USB1 event. The corresponding bit in the EDGE register must be 0.	0
		0	Level detect.	
		1	Edge detect of the USB1 event. Detect falling edge if bit 10 in the HILO register is 0. Detect rising edge if bit 10 in the HILO register is 1.	

Table 79. Edge configuration register (EDGE - address 0x4004 4004) bit description

Bit	Symbol	Value	Description	Reset value
11	SDMMC_E		Edge/level detect mode for SD/MMC event. The corresponding bit in the EDGE register must be 0.	
		0	Level detect.	
		1	Edge detect of the SD/MMC interrupt. Detect falling edge if bit 10 in the HILO register is 0. Detect rising edge if bit 10 in the HILO register is 1.	
12	CAN_E		Edge/level detect mode for C_CAN event. The corresponding bit in the EDGE register must be 0.	0
		0	Level detect.	
		1	Edge detect of the combined C_CAN interrupt. Detect falling edge if bit 12 in the HILO register is 0. Detect rising edge if bit 12 in the HILO register is 1.	
13	TIM2_E		Edge/level detect mode for combined timer output 2 event. The corresponding bit in the EDGE register must be 0.	0
		0	Level detect.	
		1	Edge detect of GIMA output 25. Detect falling edge if bit 13 in the HILO register is 0. Detect rising edge if bit 13 in the HILO register is 1.	
14	TIM6_E		Edge/level detect mode for combined timer output 6 event. The corresponding bit in the EDGE register must be 0.	0
		0	Level detect.	
		1	Edge detect of GIMA output 26. Detect falling edge if bit 14 in the HILO register is 0. Detect rising edge if bit 14 in the HILO register is 1.	
15	QEI_E		Edge/level detect mode for QEI interrupt signal. The corresponding bit in the EDGE register must be 0.	0
		0	Level detect.	
		1	Edge detect of QEI interrupt. Detect falling edge if bit 15 in the HILO register is 0. Detect rising edge if bit 15 in the HILO register is 1.	
16	TIM14_E		Edge/level detect mode for combined timer output 14 event. The corresponding bit in the EDGE register must be 0.	0
		0	Level detect.	
		1	Edge detect of GIMA output 27. Detect falling edge if bit 16 in the HILO register is 0. Detect rising edge if bit 16 in the HILO register is 1.	
18:17	-	-	Reserved.	
19	RESET_E		Edge detect of the reset signal. The corresponding bit in the EDGE register must be 0.	0
		0	Level detect.	
		1	Edge detect of the reset signal. Detect falling edge if bit 19 in the HILO register is 0. Detect rising edge if bit 19 in the HILO register is 1.	

Table 79. Edge configuration register (EDGE - address 0x4004 4004) bit description

Bit	Symbol	Value	Description	Reset value
20	BODRESET_E		Edge detect of the BOD reset signal. The corresponding bit in the EDGE register must be 0.	0
		0	Level detect.	
		1	Edge detect of the reset signal. Detect falling edge if bit 20 in the HILO register is 0. Detect rising edge if bit 19 in the HILO register is 1.	
21	DPDRESET_E		Edge detect of the deep power-down reset signal. The corresponding bit in the EDGE register must be 0.	0
		0	Level detect.	
		1	Edge detect of the reset signal. Detect falling edge if bit 21 in the HILO register is 0. Detect rising edge if bit 21 in the HILO register is 1.	
31:22	-	-	Reserved.	

9.6.3 Clear event enable register

The CLR_EN register clears the corresponding bits in the ENABLE register.

Table 80. Clear event enable register (CLR_EN - address 0x4004 4FD8) bit description

Bit	Symbol	Description	Reset value
0	WAKEUP0_CLREN	Writing a 1 to this bit clears the event enable bit 0 in the ENABLE register.	-
1	WAKEUP1_CLREN	Writing a 1 to this bit clears the event enable bit 1 in the ENABLE register.	-
2	WAKEUP2_CLREN	Writing a 1 to this bit clears the event enable bit 2 in the ENABLE register.	-
3	WAKEUP3_CLREN	Writing a 1 to this bit clears the event enable bit 3 in the ENABLE register.	-
4	ATIMER_CLREN	Writing a 1 to this bit clears the event enable bit 4 in the ENABLE register.	-
5	RTC_CLREN	Writing a 1 to this bit clears the event enable bit 5 in the ENABLE register.	-
6	BOD_CLREN	Writing a 1 to this bit clears the event enable bit 6 in the ENABLE register.	-
7	WWDT_CLREN	Writing a 1 to this bit clears the event enable bit 7 in the ENABLE register.	-
8	ETH_CLREN	Writing a 1 to this bit clears the event enable bit 8 in the ENABLE register.	-
9	USB0_CLREN	Writing a 1 to this bit clears the event enable bit 9 in the ENABLE register.	-
10	USB1_CLREN	Writing a 1 to this bit clears the event enable bit 10 in the ENABLE register.	-
11	SDMMC_CLREN	Writing a 1 to this bit clears the event enable bit 11 in the ENABLE register.	-
12	CAN_CLREN	Writing a 1 to this bit clears the event enable bit 12 in the ENABLE register.	-

Table 80. Clear event enable register (CLR_EN - address 0x4004 4FD8) bit description

Bit	Symbol	Description	Reset value
13	TIM2_CLREN	Writing a 1 to this bit clears the event enable bit 13 in the ENABLE register.	-
14	TIM6_CLREN	Writing a 1 to this bit clears the event enable bit 14 in the ENABLE register.	-
15	QEI_CLREN	Writing a 1 to this bit clears the event enable bit 15 in the ENABLE register.	-
16	TIM14_CLREN	Writing a 1 to this bit clears the event enable bit 16 in the ENABLE register.	-
18:17	-	Reserved.	-
19	RESET_CLREN	Writing a 1 to this bit clears the event enable bit 19 in the ENABLE register.	-
20	BODRESET_CLREN	Writing a 1 to this bit clears the event enable bit 20 in the ENABLE register.	-
21	DPDRESET_CLREN	Writing a 1 to this bit clears the event enable bit 21 in the ENABLE register.	-
31:22	-	Reserved.	-

9.6.4 Set event enable register

The SET_EN register sets the corresponding bits in the ENABLE register.

Table 81. Event set enable register (SET_EN - address 0x4004 4FDC) bit description

Bit	Symbol	Description	Reset value
0	WAKEUP0_SETEN	Writing a 1 to this bit sets the event enable bit 0 in the ENABLE register.	-
1	WAKEUP1_SETEN	Writing a 1 to this bit sets the event enable bit 1 in the ENABLE register.	-
2	WAKEUP2_SETEN	Writing a 1 to this bit sets the event enable bit 2 in the ENABLE register.	-
3	WAKEUP3_SETEN	Writing a 1 to this bit sets the event enable bit 3 in the ENABLE register.	-
4	ATIMER_SETEN	Writing a 1 to this bit sets the event enable bit 4 in the ENABLE register.	-
5	RTC_SETEN	Writing a 1 to this bit sets the event enable bit 5 in the ENABLE register.	-
6	BOD_SETEN	Writing a 1 to this bit sets the event enable bit 6 in the ENABLE register.	-
7	WWDT_SETEN	Writing a 1 to this bit sets the event enable bit 7 in the ENABLE register.	-
8	ETH_SETEN	Writing a 1 to this bit sets the event enable bit 8 in the ENABLE register.	-
9	USB0_SETEN	Writing a 1 to this bit sets the event enable bit 9 in the ENABLE register.	-
10	USB1_SETEN	Writing a 1 to this bit sets the event enable bit 10 in the ENABLE register.	-

Table 81. Event set enable register (SET_EN - address 0x4004 4FDC) bit description

Bit	Symbol	Description	Reset value
11	SDMMC_SETEN	Writing a 1 to this bit sets the event enable bit 11 in the ENABLE register.	-
12	CAN_SETEN	Writing a 1 to this bit sets the event enable bit 12 in the ENABLE register.	-
13	TIM2_SETEN	Writing a 1 to this bit sets the event enable bit 13 in the ENABLE register.	-
14	TIM6_SETEN	Writing a 1 to this bit sets the event enable bit 14 in the ENABLE register.	-
15	QEI_SETEN	Writing a 1 to this bit sets the event enable bit 15 in the ENABLE register.	-
16	TIM14_SETEN	Writing a 1 to this bit sets the event enable bit 16 in the ENABLE register.	-
18:17	-	Reserved.	-
19	RESET_SETEN	Writing a 1 to this bit sets the event enable bit 19 in the ENABLE register.	-
20	BODRESET_SETEN	Writing a 1 to this bit sets the event enable bit 20 in the ENABLE register.	-
21	DPDRESET_SETEN	Writing a 1 to this bit sets the event enable bit 21 in the ENABLE register.	-
31:22	-	Reserved.	-

9.6.5 Event status register

The STATUS register monitors the internally generated interrupt or event signal from the peripherals. The contents of this register can be read at any time. To change the contents of this register, use the CLR_STAT and SET_STAT registers.

Remark: The reset value for this register indicates the POR reset value.

Table 82. Event status register (STATUS - address 0x4004 4FE0) bit description

Bit	Symbol	Description	Reset value
0	WAKEUP0_ST	A 1 in this bit indicates that the WAKEUP0 event has been raised.	1
1	WAKEUP1_ST	A 1 in this bit indicates that the WAKEUP1 event has been raised.	1
2	WAKEUP2_ST	A 1 in this bit indicates that the WAKEUP2 event has been raised.	1
3	WAKEUP3_ST	A 1 in this bit indicates that the WAKEUP3 event has been raised.	1
4	ATIMER_ST	A 1 in this bit indicates that the ATIMER event has been raised.	1
5	RTC_ST	A 1 in this bit indicates that the RTC event has been raised.	1
6	BOD_ST	A 1 in this bit indicates that the BOD event has been raised.	1
7	WWDT_ST	A 1 in this bit indicates that the WWDT event has been raised.	1

Table 82. Event status register (STATUS - address 0x4004 4FE0) bit description

Bit	Symbol	Description	Reset value
8	ETH_ST	A 1 in this bit indicates that the ETHERNET event has been raised.	1
9	USB0_ST	A 1 in this bit indicates that the USB0 event has been raised.	1
10	USB1_ST	A 1 in this bit indicates that the USB1 event has been raised.	1
11	SDMMC_ST	A 1 in this bit indicates that the SDMMC event has been raised.	1
12	CAN_ST	A 1 in this bit indicates that the C_CAN event has been raised.	1
13	TIM2_ST	A 1 in this bit indicates that the combined timer 2 output event has been raised.	1
14	TIM6_ST	A 1 in this bit indicates that the combined timer 6 output event has been raised.	1
15	QEI_ST	A 1 in this bit indicates that the QEI event has been raised.	1
16	TIM14_ST	A 1 in this bit indicates that the combined timer 14 output event has been raised.	1
18:17	-	Reserved.	-
19	RESET_ST	A 1 in this bit indicates that the reset event has been raised.	1
20	BODRESET_ST	A 1 in this bit indicates that the reset event has been raised.	1
21	DPDRESET_ST	A 1 in this bit indicates that the reset event has been raised.	1
31:22	-	Reserved.	-

9.6.6 Event enable register

The ENABLE register enables or disables the propagation of the interrupt or events which are recorded in the STATUS register to the event router interrupt. The ENABLE register does not prevent an interrupt or event from being recorded in the STATUS register.

The ENABLE register can be read at any time. To change the contents of this register, use the CLR_EN and SET_EN registers.

Table 83. Event enable register (ENABLE - address 0x4004 4FE4) bit description

Bit	Symbol	Description	Reset value
0	WAKEUP0_EN	A 1 in this bit indicates that the WAKEUP0 event has been enabled. This event wakes up the chip and contributes to the event router interrupt when bit 0 = 1 in the STATUS register.	0
1	WAKEUP1_EN	A 1 in this bit indicates that the WAKEUP1 event has been enabled. This event wakes up the chip and contributes to the event router interrupt when bit 0 = 1 in the STATUS register.	0
2	WAKEUP2_EN	A 1 in this bit indicates that the WAKEUP2 event has been enabled. This event wakes up the chip and contributes to the event router interrupt when bit 0 = 1 in the STATUS register.	0

Table 83. Event enable register (ENABLE - address 0x4004 4FE4) bit description

Bit	Symbol	Description	Reset value
3	WAKEUP3_EN	A 1 in this bit indicates that the WAKEUP3 event has been enabled. This event wakes up the chip and contributes to the event router interrupt when bit 0 = 1 in the STATUS register.	0
4	ATIMER_EN	A 1 in this bit indicates that the ATIMER event has been enabled. This event wakes up the chip and contributes to the event router interrupt when bit 0 = 1 in the STATUS register.	0
5	RTC_EN	A 1 in this bit indicates that the RTC event has been enabled. This event wakes up the chip and contributes to the event router interrupt when bit 0 = 1 in the STATUS register.	0
6	BOD_EN	A 1 in this bit indicates that the BOD event has been enabled. This event wakes up the chip and contributes to the event router interrupt when bit 0 = 1 in the STATUS register.	0
7	WWDT_EN	A 1 in this bit indicates that the WWDT event has been enabled. This event wakes up the chip and contributes to the event router interrupt when bit 0 = 1 in the STATUS register.	0
8	ETH_EN	A 1 in this bit indicates that the ETHERNET event has been enabled. This event wakes up the chip and contributes to the event router interrupt when bit 0 = 1 in the STATUS register.	0
9	USB0_EN	A 1 in this bit indicates that the USB0 event has been enabled. This event wakes up the chip and contributes to the event router interrupt when bit 0 = 1 in the STATUS register.	0
10	USB1_EN	A 1 in this bit indicates that the USB1 event has been enabled. This event wakes up the chip and contributes to the event router interrupt when bit 0 = 1 in the STATUS register.	0
11	SDMMC_EN	A 1 in this bit indicates that the SDMMC event has been enabled. This event wakes up the chip and contributes to the event router interrupt when bit 0 = 1 in the STATUS register.	0
12	CAN_EN	A 1 in this bit indicates that the CAN event has been enabled. This event wakes up the chip and contributes to the event router interrupt when bit 0 = 1 in the STATUS register.	0
13	TIM2_EN	A 1 in this bit indicates that the TIM2 event has been enabled. This event wakes up the chip and contributes to the event router interrupt when bit 0 = 1 in the STATUS register.	0
14	TIM6_EN	A 1 in this bit indicates that the TIM6 event has been enabled. This event wakes up the chip and contributes to the event router interrupt when bit 0 = 1 in the STATUS register.	0

Table 83. Event enable register (ENABLE - address 0x4004 4FE4) bit description

Bit	Symbol	Description	Reset value
15	QEI_EN	A 1 in this bit indicates that the QEI event has been enabled. This event wakes up the chip and contributes to the event router interrupt when bit 0 = 1 in the STATUS register.	0
16	TIM14_EN	A 1 in this bit indicates that the TIM14 event has been enabled. This event wakes up the chip and contributes to the event router interrupt when bit 0 = 1 in the STATUS register.	0
18:17	-	Reserved	-
19	RESET_EN	A 1 in this bit indicates that the RESET event has been enabled. This event wakes up the chip and contributes to the event router interrupt when bit 0 = 1 in the STATUS register.	0
20	BODRESET_EN	A 1 in this bit indicates that the BOD RESET event has been enabled. This event wakes up the chip and contributes to the event router interrupt when bit 0 = 1 in the STATUS register.	0
21	DPDRESET_EN	A 1 in this bit indicates that the deep power-down RESET event has been enabled. This event wakes up the chip and contributes to the event router interrupt when bit 0 = 1 in the STATUS register.	0
31:22	-	Reserved.	-

9.6.7 Clear event status register

The CLR_STAT register clears the corresponding bit in the STATUS register.

Table 84. Clear event status register (CLR_STAT - address 0x4004 4FE8) bit description

Bit	Symbol	Description	Reset value
0	WAKEUP0_CLRST	Writing a 1 to this bit clears the STATUS event bit 0 in the STATUS register.	-
1	WAKEUP1_CLRST	Writing a 1 to this bit clears the STATUS event bit 1 in the STATUS register.	-
2	WAKEUP2_CLRST	Writing a 1 to this bit clears the STATUS event bit 2 in the STATUS register.	-
3	WAKEUP3_CLRST	Writing a 1 to this bit clears the STATUS event bit 3 in the STATUS register.	-
4	ATIMER_CLRST	Writing a 1 to this bit clears the STATUS event bit 4 in the STATUS register.	-
5	RTC_CLRST	Writing a 1 to this bit clears the STATUS event bit 5 in the STATUS register.	-
6	BOD_CLRST	Writing a 1 to this bit clears the STATUS event bit 6 in the STATUS register.	-
7	WWDT_CLRST	Writing a 1 to this bit clears the STATUS event bit 7 in the STATUS register.	-
8	ETH_CLRST	Writing a 1 to this bit clears the STATUS event bit 8 in the STATUS register.	-

Table 84. Clear event status register (CLR_STAT - address 0x4004 4FE8) bit description

Bit	Symbol	Description	Reset value
9	USB0_CLRST	Writing a 1 to this bit clears the STATUS event bit 9 in the STATUS register.	-
10	USB1_CLRST	Writing a 1 to this bit clears the STATUS event bit 10 in the STATUS register.	-
11	SDMMC_CLRST	Writing a 1 to this bit clears the STATUS event bit 11 in the STATUS register.	-
12	CAN_CLRST	Writing a 1 to this bit clears the STATUS event bit 12 in the STATUS register.	-
13	TIM2_CLRST	Writing a 1 to this bit clears the STATUS event bit 13 in the STATUS register.	-
14	TIM6_CLRST	Writing a 1 to this bit clears the STATUS event bit 14 in the STATUS register.	-
15	QEI_CLRST	Writing a 1 to this bit clears the STATUS event bit 15 in the STATUS register.	-
16	TIM14_CLRST	Writing a 1 to this bit clears the STATUS event bit 16 in the STATUS register.	-
18:17	-		-
19	RESET_CLRST	Writing a 1 to this bit clears the STATUS event bit 19 in the STATUS register.	-
20	BODRESET_CLRST	Writing a 1 to this bit clears the STATUS event bit 20 in the STATUS register.	-
21	DPDRESET_CLRST	Writing a 1 to this bit clears the STATUS event bit 21 in the STATUS register.	-
31:22	-	Reserved.	-

9.6.8 Set event status register

The SET_STAT register sets the corresponding bit in the STATUS register.

Table 85. Set event status register (SET_STAT - address 0x4004 4FEC) bit description

Bit	Symbol	Description	Reset value
0	WAKEUP0_SETST	Writing a 1 to this bit sets the STATUS event bit 0 in the STATUS register.	-
1	WAKEUP1_SETST	Writing a 1 to this bit sets the STATUS event bit 1 in the STATUS register.	-
2	WAKEUP2_SETST	Writing a 1 to this bit sets the STATUS event bit 2 in the STATUS register.	-
3	WAKEUP3_SETST	Writing a 1 to this bit sets the STATUS event bit 3 in the STATUS register.	-
4	ATIMER_SETST	Writing a 1 to this bit sets the STATUS event bit 4 in the STATUS register.	-
5	RTC_SETST	Writing a 1 to this bit sets the STATUS event bit 5 in the STATUS register.	-
6	BOD_SETST	Writing a 1 to this bit sets the STATUS event bit 6 in the STATUS register.	-

Table 85. Set event status register (SET_STAT - address 0x4004 4FEC) bit description

Bit	Symbol	Description	Reset value
7	WWDT_SETST	Writing a 1 to this bit sets the STATUS event bit 7 in the STATUS register.	-
8	ETH_SETST	Writing a 1 to this bit sets the STATUS event bit 8 in the STATUS register.	-
9	USB0_SETST	Writing a 1 to this bit sets the STATUS event bit 9 in the STATUS register.	-
10	USB1_SETST	Writing a 1 to this bit sets the STATUS event bit 10 in the STATUS register.	-
11	SDMMC_SETST	Writing a 1 to this bit sets the STATUS event bit 11 in the STATUS register.	-
12	CAN_SETST	Writing a 1 to this bit sets the STATUS event bit 12 in the STATUS register.	-
13	TIM2_SETST	Writing a 1 to this bit sets the STATUS event bit 13 in the STATUS register.	-
14	TIM6_SETST	Writing a 1 to this bit sets the STATUS event bit 14 in the STATUS register.	-
15	QEI_SETST	Writing a 1 to this bit sets the STATUS event bit 15 in the STATUS register.	-
16	TIM14_SETST	Writing a 1 to this bit sets the STATUS event bit 16 in the STATUS register.	-
18:17	-	Reserved.	-
19	RESET_SETST	Writing a 1 to this bit sets the STATUS event bit 19 in the STATUS register.	-
20	BODRESET_SETST	Writing a 1 to this bit sets the STATUS event bit 20 in the STATUS register.	-
21	DPDRESET_SETST	Writing a 1 to this bit sets the STATUS event bit 21 in the STATUS register.	-
31:22	-	Reserved.	-

10.1 How to read this chapter

The available peripherals vary for different parts.

- Ethernet: available only on LPC185x/3x.
- USB0: available only on LPC185x/3x/2x.
- USB1: available only on LPC185x/3x.
- AES: only available on secure parts.

If a peripheral is not available, the corresponding bits in the CREG registers are reserved.

The following registers or register bits are implemented only on parts with on-chip flash:

- USB0FLADJ register
- USB1FLADJ register
- FALSHCFGA register
- FLASHCFGB register
- SAMPLECTRL bit in the CREG0 register

10.2 Basic configuration

The CREG block is configured as follows:

- See [Table 86](#) for clocking and power control.
- The CREG block cannot be reset by software.

Table 86. CREG clocking and power control

	Base clock	Branch clock	Operating frequency
CREG	BASE_M3_CLK	CLK_M3_CREG	up to 180 MHz

10.3 Features

Multiple functions of the LPC18xx are controlled in the CREG block:

- ETB SRAM configuration
- BOD trip settings
- RTC Oscillator output
- DMA-to-peripheral muxing
- Ethernet mode
- Memory mapping
- Timer/UART inputs
- USB PHY control
- RTC_ALARM and WAKEUP0/1 pin functions
- On parts with on-chip flash:
 - Flash wait states and power control for flash banks A and B
 - USB frame length adjust registers

In addition, the CREG block contains the part id and the part configuration information.

10.4 Register description

Table 87. Register overview: Configuration registers (base address 0x4004 3000)

Name	Access	Address offset	Description	Reset value	Reset value after EMC, UART0/3 boot	Reset value after USB0/1 boot	Reference
-	-	0x000	Reserved	-	-	-	-
CREG0	R/W	0x004	Chip configuration register 32 kHz oscillator output and BOD control register. Also configures WAKEUP and SAMPLE pins.	-	0xF3C	0xF1C	Table 88
CREG1	R/W	0x008	Chip Configuration register 1. Controls wake-up using USB in deep-sleep mode.	-	0x3030DB	0x3030DB	Table 89
-	-	0x00C - 0x0FC	Reserved	-	-	-	-
M3MEMMAP	R/W	0x100	ARM Cortex-M3 memory mapping	0x1040000	0x1000000	0x1000000	Table 90
-	-	0x104 - 0x114	Reserved	-	-	-	-
CREG5	R/W	0x118	Chip configuration register 5. Controls JTAG access.	-	0x40000260	-	Table 91
DMAMUX	R/W	0x11C	DMA mux control register	-	-	-	Table 92
FLASHCFGGA	R/W	0x120	Flash accelerator configuration register for flash bank A	0x8000F03A	-	-	Table 93
FLASHCFGGB	R/W	0x124	Flash accelerator configuration register for flash bank B	0x8000F03A	-	-	Table 94
ETBCFG	R/W	0x128	ETB RAM configuration	0x1	0x1	0x1	Table 95
CREG6	R/W	0x12C	Chip configuration register 6. Controls multiple functions: Ethernet interface, SCT output, I2S0/1 inputs, EMC clock.	0	-	-	Table 96
-	-	0x130 - 0x1FC	Reserved	-	-	-	-
CHIPID	RO	0x200	Chip ID	-	-	-	Table 97
-	-	0x204 - 0x4FC	Reserved	-	-	-	-
USB0FLADJ	R/W	0x500	USB0 frame length adjust register	0x20	-	-	Table 98
USB1FLADJ	R/W	0x600	USB1 frame length adjust register	0x20	-	-	Table 99

10.4.1 CREG0 control register

Table 88. CREG0 register (CREG0, address 0x4004 3004) bit description

Bit	Symbol	Value	Description	Reset value	Access
0	EN1KHZ		Enable 1 kHz output.	0	R/W
		0	1 kHz output disabled.		
		1	1 kHz output enabled.		
1	EN32KHZ		Enable 32 kHz output	0	R/W
		0	32 kHz output disabled.		
		1	32 kHz output enabled.		
2	RESET32KHZ		32 kHz oscillator reset	1	R/W
		0	Clear reset.		
		1	Reset active.		
3	PD32KHZ		32 kHz power control.	1	R/W
		0	Powered.		
		1	Powered-down.		
4	-		Reserved	-	-
5	USB0PHY		USB0 PHY power control.	1	R/W
		0	Enable USB0 PHY power.		
		1	Disable USB0 PHY. PHY powered down.		
7:6	ALARMCTRL		RTC_ALARM pin output control	0	R/W
		0x0	RTC alarm.		
		0x1	Event router event.		
		0x2	Reserved.		
		0x3	Inactive.		
9:8	BODLVL1		BOD trip level to generate an interrupt. See the LPC18xx data sheets for the trip values.	0x3	R/W
		0x0	Level 0 interrupt		
		0x1	Level 1 interrupt		
		0x2	Level 2 interrupt		
		0x3	Level 3 interrupt		
11:10	BODLVL2		BOD trip level to generate a reset. See the LPC18xx data sheets for the trip values.	0x3	R/W
		0x0	Level 0 reset		
		0x1	Level 1 reset		
		0x2	Level 2 reset		
		0x3	Level 3 reset		

Table 88. CREG0 register (CREG0, address 0x4004 3004) bit description ...continued

Bit	Symbol	Value	Description	Reset value	Access
13:12	SAMPLECTRL		SAMPLE pin input/output control	0	R/W
		0x0	Reserved		
		0x1	Sample output from the event monitor/recorder.		
		0x2	Output from the event router.		
		0x3	Reserved.		
15:14	WAKEUP0CTRL		WAKEUP0 pin input/output control	0	R/W
		0x0	Input to the event router.		
		0x1	Output from the event router.		
		0x2	Reserved.		
		0x3	Input to the event router.		
17:16	WAKEUP1CTRL		WAKEUP1 pin input/output control	0	R/W
		0x0	Input to event router.		
		0x1	Output from the event router.		
		0x2	Reserved		
		0x3	Input to event router.		
31:18	-		Reserved	-	-

10.4.2 CREG1 control register

Table 89. CREG1 register (CREG1, address 0x4004 3008) bit description

Bit	Symbol	Value	Description	Reset value	Access
8:0	-	-	Reserved	-	-
9	USB0_PHY_PWREN_LP		USB0 PHY power control in low power mode. Set this bit to enable the power to USB0 PHY in low power mode. This enables wake-up using USB0 peripheral in deep-sleep mode.	0	R/W
		0	USB0 PHY power disabled in low power mode.		
		1	USB0 PHY power enabled in low power mode.		
10	USB1_PHY_PWREN_LP		USB1 PHY power control in low power mode. Set this bit to enable the power to USB1 PHY in low power mode. This enables wake-up using USB1 peripheral in deep-sleep mode.	0	R/W
		0	USB1 PHY power disabled in low power mode.		
		1	USB1 PHY power enabled in low power mode.		
31:11	-	-	Reserved	-	-

Remark: The wake-up from deep-sleep using USB0 and USB1 is supported only in flash based devices and is not supported in flashless devices.

10.4.3 ARM Cortex-M3 memory mapping register

The reset value for this register depends on the execution of the boot loader. See [Table 87](#). All memory mapped addresses must be located on a 4 kB boundary.

Table 90. Memory mapping register (M3MEMMAP, address 0x4004 3100) bit description

Bit	Symbol	Description	Reset value	Access
11:0		Reserved	0x000	-
31:12	M3MAP	Shadow address when accessing memory at address 0x0000 0000	-	R/W

10.4.4 CREG5 control register

Use this register to disable the JTAG for the M3 core. By default the JTAG access is enabled unless an AES key is programmed and the device is a secure device.

Remark: Disabling the JTAG can only be reversed by resetting the part through any available reset.

Table 91. CREG5 control register (CREG5, address 0x4004 3118) bit description

Bit	Symbol	Value	Description	Reset value	Access value
10:0	-		Reserved.	-	-
11	M3TAPSEL		JTAG debug disable for M3 main processor. If this bit is set to 1, it can be changed to 0 only through a chip reset.	0	R/W
		0	No effect.		
		1	Disable JTAG debug. Once JTAG is disabled, JTAG access remains disabled until the chip is reset by any source.		
31:12	-		Reserved.	-	-

10.4.5 DMA mux control register

This register controls which set of peripherals is connected to the DMA controller (see [Table 252](#)).

Remark: On secure parts, the AES DMA API configures the DMA connections in this register. See [Table 67 “AES API calls”](#).

Table 92. DMA mux control register (DMAMUX, address 0x4004 311C) bit description

Bit	Symbol	Value	Description	Reset value	Access value
1:0	DMAMUXPER0		Select DMA to peripheral connection for DMA peripheral 0.	0	R/W
		0x0	SPIFI		
		0x1	SCT match 2		
		0x2	Reserved		
		0x3	Timer3 match 1		

Table 92. DMA mux control register (DMAMUX, address 0x4004 311C) bit description

Bit	Symbol	Value	Description	Reset value	Access
3:2	DMAMUXPER1		Select DMA to peripheral connection for DMA peripheral 1	0	R/W
		0x0	Timer0 match 0		
		0x1	USART0 transmit		
		0x2	Reserved		
		0x3	AES in		
5:4	DMAMUXPER2		Select DMA to peripheral connection for DMA peripheral 2.	0	R/W
		0x0	Timer0 match 1		
		0x1	USART0 receive		
		0x2	Reserved		
		0x3	AES out		
7:6	DMAMUXPER3		Select DMA to peripheral connection for DMA peripheral 3.	0	R/W
		0x0	Timer1 match 0		
		0x1	UART1 transmit		
		0x2	I2S1 DMA request 1		
		0x3	SSP1 transmit		
9:8	DMAMUXPER4		Select DMA to peripheral connection for DMA peripheral 4.	0	R/W
		0x0	Timer1 match 1		
		0x1	UART1 receive		
		0x2	I2S1 DMA request 2		
		0x3	SSP1 receive		
11:10	DMAMUXPER5		Select DMA to peripheral connection for DMA peripheral 5.	0	R/W
		0x0	Timer2 match 0		
		0x1	USART2 transmit		
		0x2	SSP1 transmit		
		0x3	Reserved		
13:12	DMAMUXPER6		Selects DMA to peripheral connection for DMA peripheral 6.	0	R/W
		0x0	Timer2 match 1		
		0x1	USART2 receive		
		0x2	SSP1 receive		
		0x3	Reserved		
15:14	DMAMUXPER7		Selects DMA to peripheral connection for DMA peripheral 7.	0	R/W
		0x0	Timer3 match 0		
		0x1	USART3 transmit		
		0x2	SCT DMA request 0		
		0x3	Reserved		

Table 92. DMA mux control register (DMAMUX, address 0x4004 311C) bit description

Bit	Symbol	Value	Description	Reset value	Access
17:16	DMAMUXPER8		Select DMA to peripheral connection for DMA peripheral 8.	0	R/W
		0x0	Timer3 match 1		
		0x1	USART3 receive		
		0x2	SCT DMA request 1		
		0x3	Reserved		
19:18	DMAMUXPER9		Select DMA to peripheral connection for DMA peripheral 9.	0	R/W
		0x0	SSP0 receive		
		0x1	I2S0 DMA request 1		
		0x2	SCT DMA request 1		
		0x3	Reserved		
21:20	DMAMUXPER10		Select DMA to peripheral connection for DMA peripheral 10.	0	R/W
		0x0	SSP0 transmit		
		0x1	I2S0 DMA request 2		
		0x2	SCT DMA request 0		
		0x3	Reserved		
23:22	DMAMUXPER11		Selects DMA to peripheral connection for DMA peripheral 11.	0	R/W
		0x0	SSP1 receive		
		0x1	Reserved		
		0x2	USART0 transmit		
		0x3	Reserved		
25:24	DMAMUXPER12		Select DMA to peripheral connection for DMA peripheral 12.	0	R/W
		0x0	SSP1 transmit		
		0x1	Reserved		
		0x2	USART0 receive		
		0x3	Reserved		
27:26	DMAMUXPER13		Select DMA to peripheral connection for DMA peripheral 13.	0	R/W
		0x0	ADC0		
		0x1	AES in		
		0x2	SSP1 receive		
		0x3	USART3 receive		
29:28	DMAMUXPER14		Select DMA to peripheral connection for DMA peripheral 14.	0	R/W
		0x0	ADC1		
		0x1	AES out		
		0x2	SSP1 transmit		
		0x3	USART3 transmit		

Table 92. DMA mux control register (DMAMUX, address 0x4004 311C) bit description

Bit	Symbol	Value	Description	Reset value	Access
31:30	DMAMUXPER15		Select DMA to peripheral connection for DMA peripheral 15.	0	R/W
		0x0	DAC		
		0x1	SCT match 3		
		0x2	Reserved		
		0x3	Timer3 match 0		

10.4.6 Flash Accelerator Configuration register for flash bank A

Remark: This register is implemented on parts with on-chip flash only. See [Section 10.1](#).

Following reset, flash accelerator functions are enabled and flash access timing is set to a default value of 16 clocks.

Changing the FLASHCFG register value causes the flash accelerator to invalidate all of the holding latches, resulting in new reads of flash information as required. This guarantees synchronization of the flash accelerator to CPU operation.

Remark: Do not change the bit settings.

Table 93. Flash Accelerator Configuration for flash bank A register (FLASHCFG - address 0x4004 3120) bit description

Bit	Symbol	Value	Description	Reset value
11:0	-	-	Reserved. Do not change these bits from the reset value.	0x3A
15:12	FLASHTIM		Flash access time. The value of this field plus 1 gives the number of BASE_M3_CLK clocks used for a flash access. Warning: Improper setting of this value may result in incorrect operation of the device. All other values are allowed but may not be optimal for the supported clock frequencies.	0xF
		0x0	1 BASE_M3_CLK clock. Use for BASE_M3_CLK up to 21 MHz.	
		0x1	2 BASE_M3_CLK clocks. Use for BASE_M3_CLK up to 43 MHz.	
		0x2	3 BASE_M3_CLK clocks. Use for BASE_M3_CLK up to 64 MHz.	
		0x3	4 BASE_M3_CLK clocks. Use for BASE_M3_CLK up to 86 MHz.	
		0x4	5 BASE_M3_CLK clocks. Use for BASE_M3_CLK up to 107 MHz.	
		0x5	6 BASE_M3_CLK clocks. Use for BASE_M3_CLK up to 129 MHz.	
		0x6	7 BASE_M3_CLK clocks. Use for BASE_M3_CLK up to 150 MHz.	
		0x7	8 BASE_M3_CLK clocks. Use for BASE_M3_CLK up to 172 MHz.	
		0x8	9 BASE_M3_CLK clocks. Use for BASE_M3_CLK up to 180 MHz. Safe setting for all allowed conditions.	
30:16	-		Reserved. Write only zeros to these bits.	0
31	POW		Flash bank A power control	1
		0	Power-down	
		1	Active (Default)	

10.4.7 Flash Accelerator Configuration register for flash bank B

Remark: This register is implemented on parts with on-chip flash only. See [Section 10.1](#).

Following reset, flash accelerator functions are enabled and flash access timing is set to a default value of 16 clocks.

Changing the FLASHCFG register value causes the flash accelerator to invalidate all of the holding latches, resulting in new reads of flash information as required. This guarantees synchronization of the flash accelerator to CPU operation.

Remark: Bits 11 to 0 of the FLASHCFG register control internal flash accelerator functions and should not be altered.

Table 94. Flash Accelerator Configuration for flash bank B register (FLASHCFGB - address 0x4004 3124) bit description

Bit	Symbol	Value	Description	Reset value
11:0	-	-	Reserved. Do not change these bits from the reset value.	0x3A
15:12	FLASHTIM		Flash access time. The value of this field plus 1 gives the number of BASE_M3_CLK clocks used for a flash access. Warning: Improper setting of this value may result in incorrect operation of the device. All other values are allowed but may not be optimal for the supported clock frequencies.	0xF
		0x0	1 BASE_M3_CLK clock. Use for BASE_M3_CLK up to 21 MHz.	
		0x1	2 BASE_M3_CLK clocks. Use for BASE_M3_CLK up to 43 MHz.	
		0x2	3 BASE_M3_CLK clocks. Use for BASE_M3_CLK up to 64 MHz.	
		0x3	4 BASE_M3_CLK clocks. Use for BASE_M3_CLK up to 86 MHz.	
		0x4	5 BASE_M3_CLK clocks. Use for BASE_M3_CLK up to 107 MHz.	
		0x5	6 BASE_M3_CLK clocks. Use for BASE_M3_CLK up to 129 MHz.	
		0x6	7 BASE_M3_CLK clocks. Use for BASE_M3_CLK up to 150 MHz.	
		0x7	8 BASE_M3_CLK clocks. Use for BASE_M3_CLK up to 172 MHz.	
		0x8	9 BASE_M3_CLK clocks. Use for BASE_M3_CLK up to 180 MHz. Safe setting for all allowed conditions.	
30:16	-		Reserved. Write only zeros to these bits.	0
31	POW		Flash bank B power control	1
		0	Power-down	
		1	Active (Default)	

10.4.8 ETB SRAM configuration register

This register selects how the 16 kB block of RAM located at address 0x2000 C000 is used. This RAM memory block can be accessed either by the ETB or be used as normal SRAM on the AHB bus.

Table 95. ETB SRAM configuration register (ETBCFG, address 0x4004 3128) bit description

Bit	Symbol	Value	Description	Reset value	Access
0	ETB		Select SRAM interface	1	R/W
		0	ETB accesses SRAM at address 0x2000 C000.		
		1	AHB accesses SRAM at address 0x2000 C000.		
31:1	-		Reserved.	-	-

10.4.9 CREG6 control register

This register controls various aspects of the LPC18xx:

- Bits 2:0 control the Ethernet PHY interface. The ethernet block reads this register during set-up. Therefore the ethernet must be reset after changing the PHY interface.

- Bit 4 selects the functionality of SCT outputs connected to the CTOUT_n pins and selected GIMA inputs:
 - SCT output ORed with timer match output (default). See [Table 636](#).
 - SCT output only.
- Bits 15:12 control the I2S clock connections.
- Bit 16 controls the external memory controller clocking.

Table 96. CREG6 control register (CREG6, address 0x4004 312C) bit description

Bit	Symbol	Value	Description	Reset value	Access
2:0	ETHMODE		Selects the Ethernet mode. Reset the ethernet after changing the PHY interface. All other settings are reserved.		R/W
		0x0	MII		
		0x4	RMII		
3	-		Reserved.	-	-
4	CTOUTCTRL		Selects the functionality of the SCT output.	0	R/W
		0	Combine SCT and timer match outputs. SCT outputs are ORed with timer outputs.		
		1	SCT outputs only. SCT outputs are used without timer match outputs.		
11:5	-		Reserved.	-	-
12	I2S0_TX_SCK_IN_SEL		I2S0_TX_SCK input select	0	R/W
		0	I2S register. I2S clock selected as defined by the I2S transmit mode register Table 923 .		
		1	BASE_AUDIO_CLK for I2S transmit clock MCLK input and MCLK output. The I2S must be configured in slave mode.		
13	I2S0_RX_SCK_IN_SEL		I2S0_RX_SCK input select	0	R/W
		0	I2S register. I2 S clock selected as defined by the I2S receive mode register Table 924 .		
		1	BASE_AUDIO_CLK for I2S receive clock MCLK input and MCLK output. The I2S must be configured in slave mode.		
14	I2S1_TX_SCK_IN_SEL		I2S1_TX_SCK input select	0	R/W
		0	I2S register. I2S clock selected as defined by the I2S transmit mode register Table 923 .		
		1	BASE_AUDIO_CLK for I2S transmit clock MCLK input and MCLK output. The I2S must be configured in slave mode.		
15	I2S1_RX_SCK_IN_SEL		I2S1_RX_SCK input select	0	R/W
		0	I2S register. I2S clock selected as defined by the I2S receive mode register Table 924 .		
		1	BASE_AUDIO_CLK for I2S receive clock MCLK input and MCLK output. The I2S must be configured in slave mode.		
16	EMC_CLK_SEL		EMC_CLK divided clock select (see Section 22.1).	0	R/W
		0	Divide by 1. EMC_CLK_DIV not divided.		
		1	Divide by 2. EMC_CLK_DIV divided by 2.		
31:17	-		Reserved.	-	-

10.4.10 Chip ID register

Table 97. Chip ID register (CHIPID, address 0x4004 3200) bit description

Bit	Symbol	Description	Reset value	Access
31:0	ID	Boundary scan ID code 0x5284 E02B or 0x6284 E02B = LPC1850/30/20/10 (flashless parts), and LPC18S50/S30/S20/S10 (flashless parts) 0x4284 E02B = LPC185x/3x/2x/1x and LPC18S57/S37 (Rev '-' parts with on-chip flash) 0x7284 E02B = LPC185x/3x/2x/1x and LPC18S57/S37 (Rev A parts with on-chip flash)	-	R

10.4.11 USB0 frame length adjust register

Remark: This register is only implemented for parts with on-chip flash. See [Section 10.1](#). This register should be read before the initialization of USB0.

The USB frame length adjust register is used to adjust any offset from the clock source that generates the clock that drives the SOF counter. When a new value is written into these six bits, the length of the frame is adjusted. Its initial programmed value is system dependent based on the accuracy of hardware USB clock. This register should only be modified when the HCH bit in the USB STS register is one. Changing value of this register while the host controller is operating yields undefined results.

This register should not be reprogrammed by USB system software unless the default values are incorrect, or the system is restoring the register while returning from a suspended state.

For details on using the SOF counter, see [Section 23.7.7.1](#).

Table 98. USB0 frame length adjust register (USB0FLADJ, address 0x4004 3500) bit description

Bit	Symbol	Description	Reset value	Access
5:0	FLTV	<p>Frame length timing value</p> <p>The frame length is given in the number of high-speed bit times in decimal format. Each decimal value change to this register corresponds to 16 high-speed bit times. The SOF cycle time (number of SOF counter clock periods to generate a SOF micro-frame length) is equal to 59488 + value in this field. The default value is decimal 32 (0x20), which results in a SOF cycle time of 60000.</p> <p>0x00 = 59488 (= 59488 + 0 x 16) 0x01 = 59504 (= 59488 + 1 x 16) 0x02 = 59520 (= 59488 + 2 x 16) ... 0x1F = 59984 (= 59488 + 31 x 16) 0x20 = 60000 (= 59488 + 32 x 16) ... 0x3E = 60480 (= 59488 + 62 x 16) 0x3F = 60496 (= 59488 + 63 x 16)</p>	0x20	R/W
31:6	-	Reserved	-	-

10.4.12 USB1 frame length adjust register

Remark: This register is only implemented for parts with on-chip flash. See [Section 10.1](#). This register should be read before the initialization of USB1.

The USB frame length adjust register is used to adjust any offset from the clock source that generates the clock that drives the SOF counter. When a new value is written into these six bits, the length of the frame is adjusted. Its initial programmed value is system dependent based on the accuracy of hardware USB clock. This register should only be modified when the HCH bit in the USB STS register is one. Changing value of this register while the host controller is operating yields undefined results.

This register should not be reprogrammed by USB system software unless the default values are incorrect, or the system is restoring the register while returning from a suspended state.

For details on using the SOF counter, see [Section 23.7.7.1](#).

Table 99. USB1 frame length adjust register (USB1FLADJ, address 0x4004 3600) bit description

Bit	Symbol	Description	Reset value	Access
5:0	FLTV	<p>Frame length timing value</p> <p>The frame length is given in the number of high-speed bit times in decimal format. Each decimal value change to this register corresponds to 16 high-speed bit times. The SOF cycle time (number of SOF counter clock periods to generate a SOF micro-frame length) is equal to 59488 + value in this field. The default value is decimal 32 (0x20), which results in a SOF cycle time of 60000.</p> <p>0x00 = 59488 (= 59488 + 0 x 16)</p> <p>0x01 = 59504 (= 59488 + 1 x 16)</p> <p>0x02 = 59520 (= 59488 + 2 x 16)</p> <p>...</p> <p>0x1F = 59984 (= 59488 + 31 x 16)</p> <p>0x20 = 60000 (= 59488 + 32 x 16)</p> <p>...</p> <p>0x3E = 60480 (= 59488 + 62 x 16)</p> <p>0x3F = 60496 (= 59488 + 63 x 16)</p>	0x20	R/W
31:6	-	Reserved	-	-

11.1 How to read this chapter

The power management controller is identical on all LPC18xx parts.

11.2 General description

The PMC implements the control sequences to enable transitioning between different power modes and controls the power state of each peripheral. In addition, wake-up from any of the power-down modes based on hardware events is supported.

Power-down modes can be reached from Active mode only, and transitions between Power-down modes are not allowed. Power-down modes are entered by a WFI or WFE instruction. Wake-up is caused by an interrupt or event. The interrupt cause is captured in the NVIC ([Chapter 8](#)), and events are captured in the Event router ([Chapter 9](#)).

The PMC supports the following Power-down modes: Deep-sleep, Power-down, and Deep power-down. The wake-up from any of the Power-down modes will always result in the Active mode.

The LPC18xx supports five power modes in order from highest to lowest power consumption:

1. Active mode
2. Sleep mode (controlled by the ARM Cortex-M3 core)
3. Power-down modes:
 - a. Deep-sleep mode (controlled by the ARM Cortex-M3 core)
 - b. Power-down mode (controlled by the ARM Cortex-M3 core)
 - c. Deep power-down mode

Remark: Before the Deep-sleep mode or the Power-down mode can be selected, the IRC must be selected as the clock source for all output clocks through the CGU registers (see [Section 12.8.1](#)), and all PLLs must be powered down.

11.2.1 Active mode

By default, the LPC18xx is in Active mode, which means that every peripheral can perform a functional operation at nominal operating conditions.

11.2.2 Sleep mode

In Sleep mode, the CPU clock is shut down to save power; the peripherals can still remain active and fully functional. The Sleep mode is entered by a WFI or WFE instruction if the SLEEPDEEP bit in the ARM Cortex-M3 system control register is set to 0.

The part can wake up from sleep mode through any enabled interrupt in the NVIC or any enabled event in the event router.

11.2.3 Deep-sleep mode

In Deep-sleep mode the CPU clock and peripheral clocks are shut down to save power; logic states and SRAM memory are maintained. All analog blocks and the BOD control circuit are powered down. The Deep-sleep mode is entered by a WFI or WFE instruction if the SLEEPDEEP bit in the ARM Cortex-M3 system control register is set to 1 and the PD0_SLEEP0_MODE register (see [Table 103](#)) is programmed with the Deep-sleep mode value.

When the LPC18xx wakes up from Deep-sleep mode, the 12 MHz IRC is used as the clock source for all base clocks.

Remark: Before entering Deep-sleep mode, program the CGU as follows:

- Switch the clock source of all base clocks to the IRC.
- Put the PLLs in power-down mode.

Reprogramming the CGU avoids any undefined or unlocked PLL clocks at wake-up and minimizes power consumption during Deep-sleep mode.

The part can wake up from Deep-sleep mode only through a signal on any of the WAKEUP pins or a signal from the alarm timer or RTC. The wake-up signals are enabled in the event router. See [Section 9.4](#).

11.2.4 Power-down mode

In Power-down mode the CPU clock and peripheral clocks are shut down but logic states are maintained. All SRAM memory except for the upper 8 kB of the local SRAM located at 0x1008 0000, all analog blocks, and the BOD control circuit are powered down. The Power-down mode is entered by a WFI or WFE instruction if the SLEEPDEEP bit in the ARM Cortex-M3 system control register is set to 1 and the PD0_SLEEP0_MODE register (see [Table 103](#)) is programmed with the Power-down mode value.

When the LPC18xx wakes up from Power-down mode, the 12 MHz IRC is used as the clock source for all base clocks.

Remark: Before entering Power-down mode, program the CGU as follows:

- Switch the clock source of all base clocks to the IRC.
- Put the PLLs in power-down mode.

Reprogramming the CGU avoids any undefined or unlocked PLL clocks at wake-up and minimizes power consumption during Power-down mode.

The part can wake up from Power-down mode only through a signal on any of the WAKEUP pins or a signal from the alarm timer or RTC. The wake-up signals are enabled in the event router. See [Section 9.4](#).

11.2.5 Deep power-down

In Deep power-down mode the entire core logic is powered down and the logic state of the entire system including the I/O pads is lost. Only the logic in the RTC power domain remains active. The Deep power-down mode is entered by a WFI or WFE instruction if the SLEEPDEEP bit in the ARM Cortex-M3 system control register is set to 1 and the PD0_SLEEP0_MODE register (see [Table 103](#)) is programmed with the Deep power-down

value.

When the LPC18xx wakes up from Deep power-down mode, the boot loader configures the PLL1 as the clock source running at 96 MHz and attempts to boot similar as after a reset or power-up.

The part can wake up from Deep power-down mode only through a signal on any of the WAKEUP pins or a signal from the alarm timer or RTC. The wake-up signals are enabled in the event router. See [Section 9.4](#).

11.2.6 Memory retention in Power-down modes

[Table 100](#) shows which parts of the memory are preserved in Sleep mode and the various power-down modes.

In addition, all FIFO memory contained in the peripheral blocks (USB0/1, LCD, CAN0/1, Ethernet, USART0/2/3, UART) is retained in Sleep mode and Deep-sleep mode but not in Power-down mode and Deep-power-down mode.

Table 100. Memory retention

Mode	64 kB + 32 kB local SRAM starting at 0x1000 0000	32 kB local SRAM starting at 0x1008 0000	upper 8 kB of local SRAM starting at 0x1008 8000	64 kB AHB SRAM starting at 0x2000 0000	256 byte backup registers at 0x4004 1000 (RTC power domain)
Sleep mode	yes	yes	yes	yes	yes
Deep-sleep mode	yes	yes	yes	yes	yes
Power-down mode	no	no	yes	no	yes
Deep power-down mode	no	no	no	no	yes

11.3 Register description

Table 101. Register overview: Power Mode Controller (PMC) (base address 0x4004 2000)

Name	Access	Address offset	Description	Reset value	Reference
PD0_SLEEP0_HW_ENA	R/W	0x000	Hardware sleep event enable register	0x0000 0001	Table 102
-	-	0x004 - 0x018	Reserved	-	-
PD0_SLEEP0_MODE	R/W	0x01C	Power-down mode control register	0x003F FF7F	Table 103

11.3.1 Hardware sleep event enable register PD0_SLEEP0_HW_ENA

Table 102. Hardware sleep event enable register (PD0_SLEEP0_HW_ENA - address 0x4004 2000) bit description

Bit	Symbol	Description	Reset value	Access
0	ENA_EVENT0	Writing a 1 enables the Power-down modes for the Cortex-M3 (see the PD0_SLEEP0_MODE register for selecting the mode).	1	R/W
31:1	-	Reserved, user software should not write ones to reserved bits. The value read from a reserved bit is not defined.	-	-

11.3.2 Power-down modes register PD0_SLEEP0_MODE

The PD0_SLEEP0_MODE register controls which of the three Power-down modes, Deep-sleep, Power-down, or Deep power-down is entered when an ARM WFE/WFI instruction is issued and the SLEEPDEEP bit is set to 1.

Table 103. Power-down modes register (PD0_SLEEP0_MODE - address 0x4004 201C) bit description

Bit	Symbol	Description	Reset value	Access
31:0	PWR_STATE	Selects between Deep-sleep, Power-down, and Deep power-down modes. Only one of the following three values can be programmed in this register: 0x0030 00AA = Deep-sleep mode 0x0030 FCBA = Power-down mode 0x0033 FF7F = Deep power-down mode	0x003F FF7F	R/W

11.4 Functional description

11.4.1 Run-time programming

The PD0_SLEEP0_MODE register can be programmed at run-time to change the default power state of the LPC18xx after the next transition to a reduced-power state.

Table 104. Typical settings for PMC power modes

Power-down mode	Description	PD0_SLEEP0_MODE register bit settings
Deep-sleep	CPU, peripherals, analog, USB PHY in retention mode; all SRAM supplies in active mode; BOD in power-down mode.	0x0030 00AA
Power-down	CPU, peripherals, analog supplies in retention mode; USB PHY in power-down mode; SRAM1 in active mode; all other SRAMs in power-down mode; BOD in power-down mode.	0x0030 FCBA
Deep power-down	CPU, peripherals, analog, USB PHY in power-down mode; all SRAMs in power-down mode; BOD in power-down mode.	0x0030 FF7F

12.1 How to read this chapter

Ethernet, USB0, USB1, and LCD related clocks are not available on all packages. See [Section 1.3](#). The corresponding clock control registers are reserved.

12.2 Basic configuration

The CGU is configured as follows:

- See [Table 105](#) for clocking and power control.
- Do not reset the CGU during normal operation.
- For using core clock frequencies (BASE_M3_CLK) higher than 110 MHz with the crystal oscillator, you must change the CGU configuration from the default setting in several steps. See [Section 12.2.1](#).

Table 105. CGU clocking and power control

	Base clock	Branch clock	Operating frequency
CGU	BASE_M3_CLK	CLK_M3_BUS	up to 180 MHz

12.2.1 Configuring the BASE_M3_CLK for high operating frequencies

To ramp up the clock frequency to an operating frequency above 110 MHz, configure the core clock BASE_M4_CLK as described in [Section 12.2.1.1](#).

The recommended procedure to configure BASE_M3_CLK depends on the current clock configuration of the part. There are two typical configurations:

1. After a power-up, reset, or when waking up from deep-power down mode. In these situations, the boot code executes. After the boot process has completed, the clock configuration of the part is as follows:
 - The core clock BASE_M3_CLK is connected to the output of PLL1 and running at 96 MHz.
 - The clock source for the PLL1 is the 12 MHz IRC.
2. After wake-up from Deep-sleep or power-down modes. In this case, BASE_M3_CLK is connected to the IRC running at 12 MHz.

No special requirements exist for ramping down BASE_M3_CLK or changing any of the peripheral base clocks either from low to high or from high to low frequencies.

12.2.1.1 Changing the BASE_M3_CLK after power-up, reset, or deep power-down mode

The following procedure shows how to change the default setting of the core clock (BASE_M3_CLK = 96 MHz; IRC = PLL1 clock source) to an operating frequency above 110 MHz while also changing the clock source from IRC to crystal oscillator:

1. Select the IRC as BASE_M3_CLK source.
2. Enable the crystal oscillator (see [Table 112](#)).
3. Wait 250 μ s.
4. Set the AUTOBLOCK bit (bit 11). This bit re-synchronizes the clock output during frequency changes that prevents glitches when switching clock frequencies.
5. Reconfigure PLL1 as follows (see [Table 123](#)):
 - Select the M and N divider values to produce the final desired PLL1 output frequency f_{outPLL} .
 - Select the crystal oscillator as clock source for PLL1.
6. Wait for the PLL1 to lock.
7. Set the PLL1 P-divider to divide by 2 (DIRECT = 0, PSEL=0).
8. Select PLL1 as BASE_M3_CLK source. The BASE_M3_CLK now operates in the mid-frequency range.
9. Wait 50 μ s.
10. Set the PLL1 P-divider to direct output mode (DIRECT = 1).

The BASE_M3_CLK now operates in the high-frequency range.

12.2.1.2 Changing the BASE_M3_CLK after waking up from deep-sleep or power-down modes

The following procedure shows how to ramp up the BASE_M3_CLK clock from low frequencies to the high frequency range (see [Figure 31](#)). This procedure applies after waking up from deep-sleep or power-down modes and any time the part runs at frequencies < 90 MHz.

1. If the crystal oscillator is powered down, enable the crystal oscillator (see [Table 112](#)), and wait 250 μ s.
2. Select the crystal oscillator as clock source for BASE_M3_CLK (see [Table 130](#)).
3. Set the AUTOBLOCK bit (bit 11). This bit re-synchronizes the clock output during frequency changes that prevents glitches when switching clock frequencies.
4. Reconfigure PLL1 as follows (see [Table 123](#)):
 - Select the M and N divider values to produce the final desired PLL1 output frequency f_{outPLL} .
 - Select the crystal oscillator as clock source for PLL1.
5. Wait for the PLL1 to lock.
6. Set the PLL1 P-divider to divide by 2 (DIRECT = 0, PSEL=0).
7. Select PLL1 as BASE_M3_CLK source. The BASE_M3_CLK now operates in the mid-frequency range.
8. Wait 50 μ s.
9. Set the PLL1 P-divider to direct output mode (DIRECT = 1).

The BASE_M3_CLK now operates in the high frequency range (110 MHz to 180 MHz).

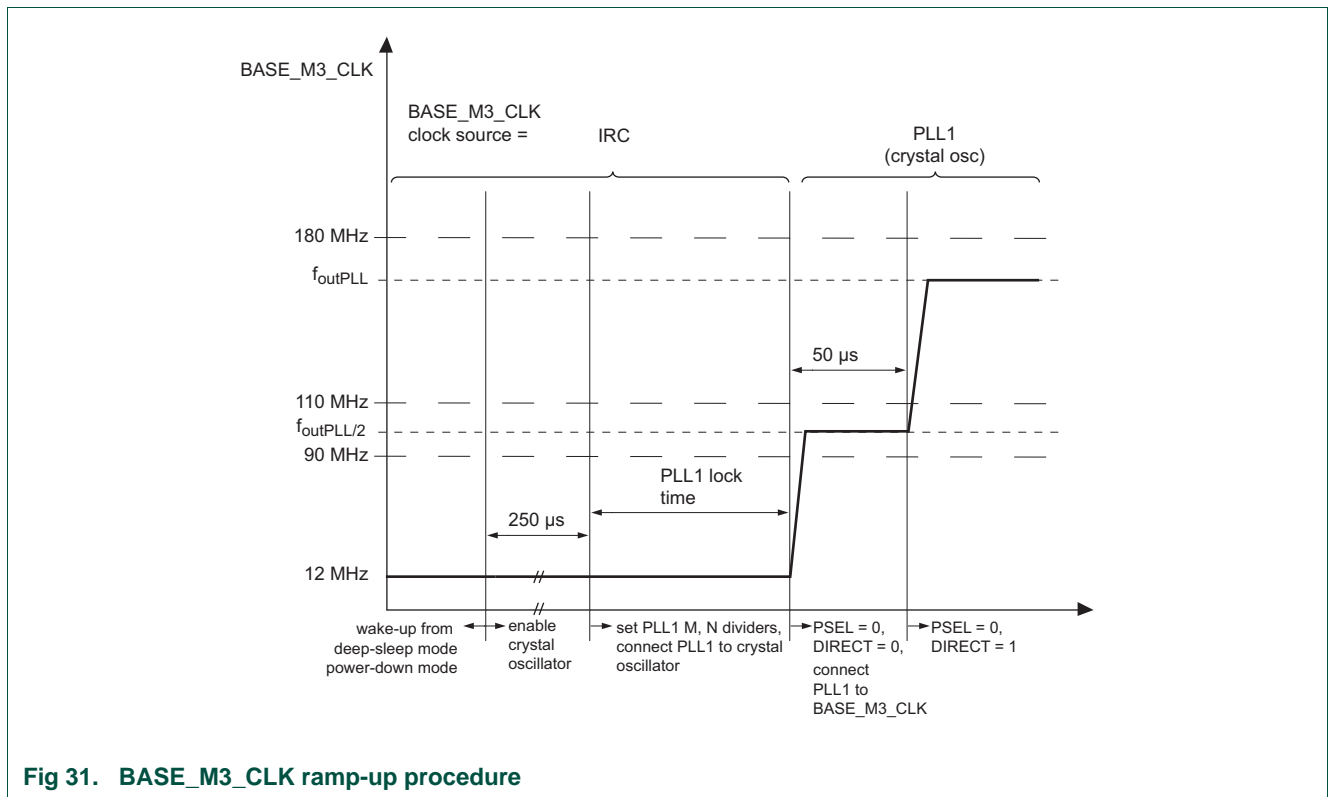

Fig 31. BASE_M3_CLK ramp-up procedure

A similar two-step procedure applies when changing the BASE_M3_CLK from low to high frequencies using the PLL0AUDIO as the clock source.

12.3 Features

- PLL control
- Supports three PLLs:
 - the PLL0USB for creating the 480 MHz clock for the high-speed USB0
 - the PLL0AUDIO with fractional divider for creating a wide variety of frequencies for audio applications with high accuracy
 - the PLL1 for creating the core and peripheral clocks.
- Oscillator control
- Clock generation and clock source multiplexing
- Integer dividers for clock output stages

12.4 General description

The CGU generates multiple independent clocks for the core and the peripheral blocks of the LPC18x. Each independent clock is called a base clock and itself is one of the inputs to the two Clock Control Units (CCUs) which control the branch clocks to the individual peripherals (see [Chapter 13](#)).

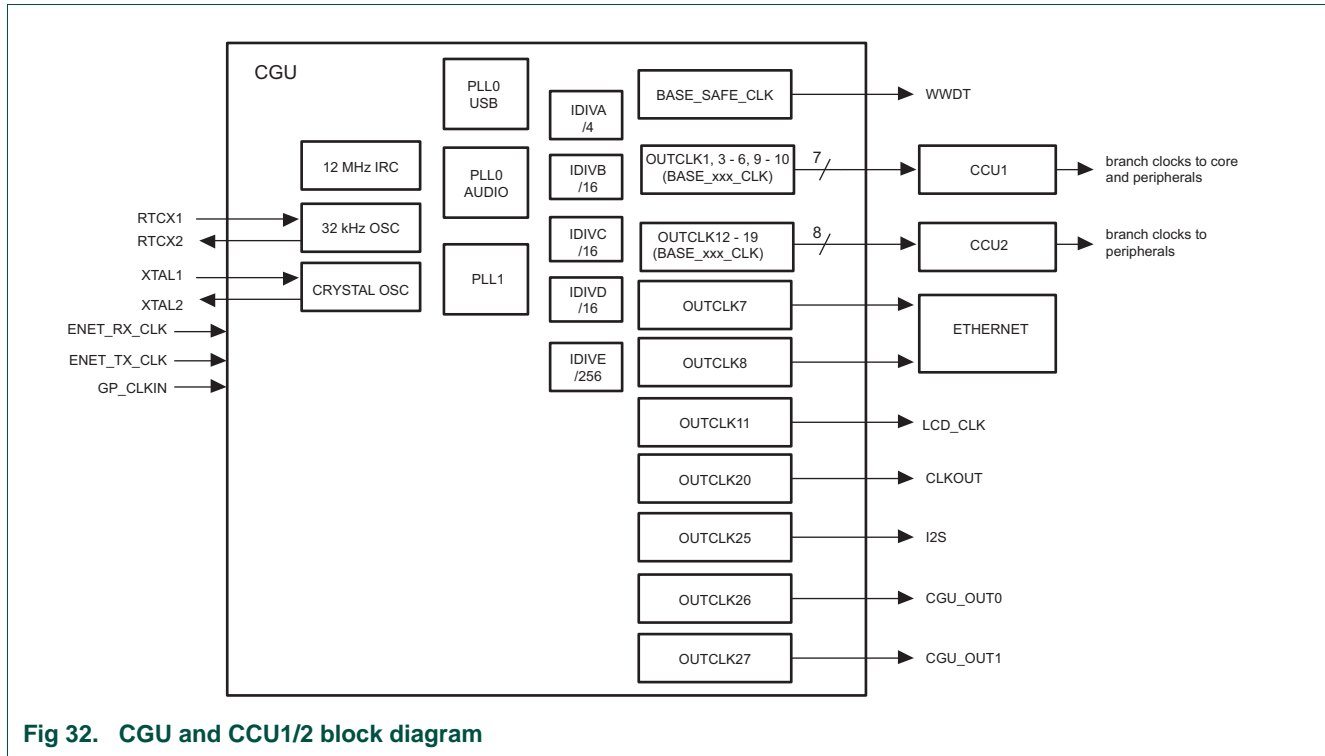

Fig 32. CGU and CCU1/2 block diagram

The CGU selects the inputs to the clock generators from multiple clock sources, controls the clock generation, and routes the outputs of the clock generators through the clock source bus to the output stages. Each output stage provides an independent clock source and corresponds to one of the base clocks for the LPC18xx. See [Table 106](#) for a description of each base clock and [Table 108](#) for the possible clock sources for each base clock.

The CGU contains four types of clock generators:

1. External clock inputs and internal clocks: The external clock inputs are the Ethernet PHY clocks and the general purpose input clock GP_CLKIN. The clocks from the internal oscillators are the IRC and the 32 kHz oscillator output clocks. These clock generators have no selectable inputs from the clock source bus and provide one clock output each to the clock source bus.
2. Crystal oscillator: The crystal oscillator is controlled by the CGU. The input to the crystal oscillator are the XTAL pins. The crystal oscillator creates one output to the clock source bus.
3. PLLs: PLL0USB, PLL0AUDIO, and PLL1 are controlled by the CGU. Each PLL can select one input from the clock source bus and provides one output to the clock source bus. The input to the PLLs can be selected from all external and internal clocks and oscillators, from the other PLLs, and from the outputs of any of the integer dividers (see [Table 107](#)). One PLL0 cannot select the other PLL0 as input.
4. Integer dividers: Each of the five integer dividers can select one input from the clock source bus and creates one divided output clock to the clock source bus. The input to all integer dividers can be selected from all external and internal clocks and oscillators, and from all three PLLs. In addition, the output of the first integer divider can be selected as an input to all other integer dividers (see [Table 107](#)).

- Integer divider A: maximum division factor = 4 (see [Table 124](#)).
- Integer dividers B, C, D: maximum division factor = 16 (see [Table 125](#)).
- Integer divider E: maximum division factor = 256 (see [Table 126](#)).

The output stages select a clock source from the clock source bus for each base clock (see [Table 108](#)). Except for the base clocks to the WWDT (BASE_SAFE_CLK) and USB0 (BASE_USB0_CLK), the clock source for each output stage can be any of the external and internal clocks and oscillators directly or one of the PLL outputs or any of the outputs of the integer dividers.

Table 106. CGU base clocks

Number	Name	Frequency [1]	Description
0	BASE_SAFE_CLK	12 MHz	Base safe clock (always on) for WWDT
1	BASE_USB0_CLK	480 MHz	Base clock for USB0
2	-	-	Reserved
3	BASE_USB1_CLK	180 MHz	Base clock for USB1
4	BASE_M3_CLK	180 MHz	System base clock for ARM Cortex-M3 core and APB peripheral blocks #0 and #2
5	BASE_SPIFI_CLK	180 MHz	Base clock for SPIFI
6	-	-	Reserved
7	BASE_PHY_RX_CLK	75 MHz	Base clock for Ethernet PHY Receive clock
8	BASE_PHY_TX_CLK	75 MHz	Base clock for Ethernet PHY Transmit clock
9	BASE_APB1_CLK	180 MHz	Base clock for APB peripheral block # 1
10	BASE_APB3_CLK	180 MHz	Base clock for APB peripheral block # 3
11	BASE_LCD_CLK	180 MHz	Base clock for LCD
12	-	-	Reserved
13	BASE_SDIO_CLK	180 MHz	Base clock for SD/MMC
14	BASE_SSP0_CLK	180 MHz	Base clock for SSP0
15	BASE_SSP1_CLK	180 MHz	Base clock for SSP1
16	BASE_UART0_CLK	180 MHz	Base clock for UART0
17	BASE_UART1_CLK	180 MHz	Base clock for UART1
18	BASE_UART2_CLK	180 MHz	Base clock for UART2
19	BASE_UART3_CLK	180 MHz	Base clock for UART3
20	BASE_OUT_CLK	180 MHz	Base clock for CLKOUT pin
21-24	-	-	Reserved
25	BASE_AUDIO_CLK	180 MHz	Base clock for audio system (I2S)
26	BASE_CGU_OUT0_CLK	180 MHz	Base clock for CGU_OUT0 clock output
27	BASE_CGU_OUT1_CLK	180 MHz	Base clock for CGU_OUT1 clock output

[1] Maximum frequency that guarantees stable operation of the LPC18xx.

[Table 107](#) shows all available input clock sources for each clock generator.

Table 107. Clock sources for clock generators with selectable inputs

Clock sources	Clock generators								
	PLL0 USB	PLL0 AUDIO	PLL1	IDIVA /4	IDIVB /16	IDIVC /16	IDIVD /16	IDIVE /256	
32 kHz oscillator	yes	yes	yes	yes	yes	yes	yes	yes	
IRC 12 MHz	yes	yes	yes	yes	yes	yes	yes	yes	
ENET_RX_CLK	yes	yes	yes	yes	yes	yes	yes	yes	
ENET_TX_CLK	yes	yes	yes	yes	yes	yes	yes	yes	
GP_CLKIN	yes	yes	yes	yes	yes	yes	yes	yes	
Crystal oscillator	yes	yes	yes	yes	yes	yes	yes	yes	
PLL0USB	no	no	yes	yes	no	no	no	no	
PLL0AUDIO	no	no	yes	yes	yes	yes	yes	yes	
PLL1	yes	yes	no	yes	yes	yes	yes	yes	
IDIVA	yes	yes	yes	no	yes	yes	yes	yes	
IDIVB	yes	yes	yes	no	no	no	no	no	
IDIVC	yes	yes	yes	no	no	no	no	no	
IDIVD	yes	yes	yes	no	no	no	no	no	
IDIVE	yes	yes	yes	no	no	no	no	no	

Table 108. Clock sources for output stages

Clock sources	Output stages (d = default clock source, y = yes (clock source available), n = no (clock source not available))																						
	BASE_SAFE_CLK	BASE_USB0_CLK	BASE_USB1_CLK	BASE_M3_CLK	BASE_SPIFI_CLK	Reserved	BASE_PHY_RX_CLK	BASE_PHY_TX_CLK	BASE_APB1_CLK	BASE_APB3_CLK	BASE_LCD_CLK	Reserved	BASE_SDIO_CLK	BASE_SSP0_CLK	BASE_SSP1_CLK	BASE_UART0_CLK	BASE_UART1_CLK	BASE_UART2_CLK	BASE_UART3_CLK	BASE_OUT_CLK	BASE_AUDIO_CLK	BASE_CGU_OUT0_CLK	BASE_CGU_OUT1_CLK
32 kHz oscillator	n	n	y	y	y	y	y	y	y	y	y	y	y	y	y	y	y	y	y	y	y	y	y
IRC 12 MHz	d	n	d	d	d	d	d	d	d	d	d	d	d	d	d	d	d	d	d	d	d	d	d
ENET_RX_CLK	n	n	y	y	y	y	y	y	y	y	y	y	y	y	y	y	y	y	y	y	y	y	y
ENET_TX_CLK	n	n	y	y	y	y	y	y	y	y	y	y	y	y	y	y	y	y	y	y	y	y	y
GP_CLKIN	n	n	y	y	y	y	y	y	y	y	y	y	y	y	y	y	y	y	y	y	y	y	y
Crystal oscillator	n	n	y	y	y	y	y	y	y	y	y	y	y	y	y	y	y	y	y	y	y	y	y
PLL0 USB	n	d	y	n	n	n	n	n	n	n	n	n	n	n	n	n	n	n	n	y	n	y	y
PLL0 AUDIO	n	n	y	y	y	y	y	y	y	y	y	y	y	y	y	y	y	y	y	y	y	y	y

Table 108. Clock sources for output stages

Output stages (d = default clock source, y = yes (clock source available), n = no (clock source not available))																								
Clock sources	BASE_SAFE_CLK	BASE_USB0_CLK	BASE_USB1_CLK	BASE_M3_CLK	BASE_SPIFI_CLK	Reserved	BASE_PHY_RX_CLK	BASE_PHY_TX_CLK	BASE_APB1_CLK	BASE_APB3_CLK	BASE_LCD_CLK	Reserved	BASE_SDIO_CLK	BASE_SSP0_CLK	BASE_SSP1_CLK	BASE_UART0_CLK	BASE_UART1_CLK	BASE_UART2_CLK	BASE_UART3_CLK	BASE_OUT_CLK	BASE_AUDIO_CLK	BASE_CGU_OUT0_CLK	BASE_CGU_OUT1_CLK	
PLL1	n	n	y	y	y	y	y	y	y	y	y	y	y	y	y	y	y	y	y	y	y	y	y	y
IDIVA	n	n	y	y	y	y	y	y	y	y	y	y	y	y	y	y	y	y	y	y	y	y	y	y
IDIVB	n	n	y	y	y	y	y	y	y	y	y	y	y	y	y	y	y	y	y	y	y	y	y	y
IDIVC	n	n	y	y	y	y	y	y	y	y	y	y	y	y	y	y	y	y	y	y	y	y	y	y
IDIVD	n	n	y	y	y	y	y	y	y	y	y	y	y	y	y	y	y	y	y	y	y	y	y	y
IDIVE	n	n	y	y	y	y	y	y	y	y	y	y	y	y	y	y	y	y	y	y	y	y	y	y

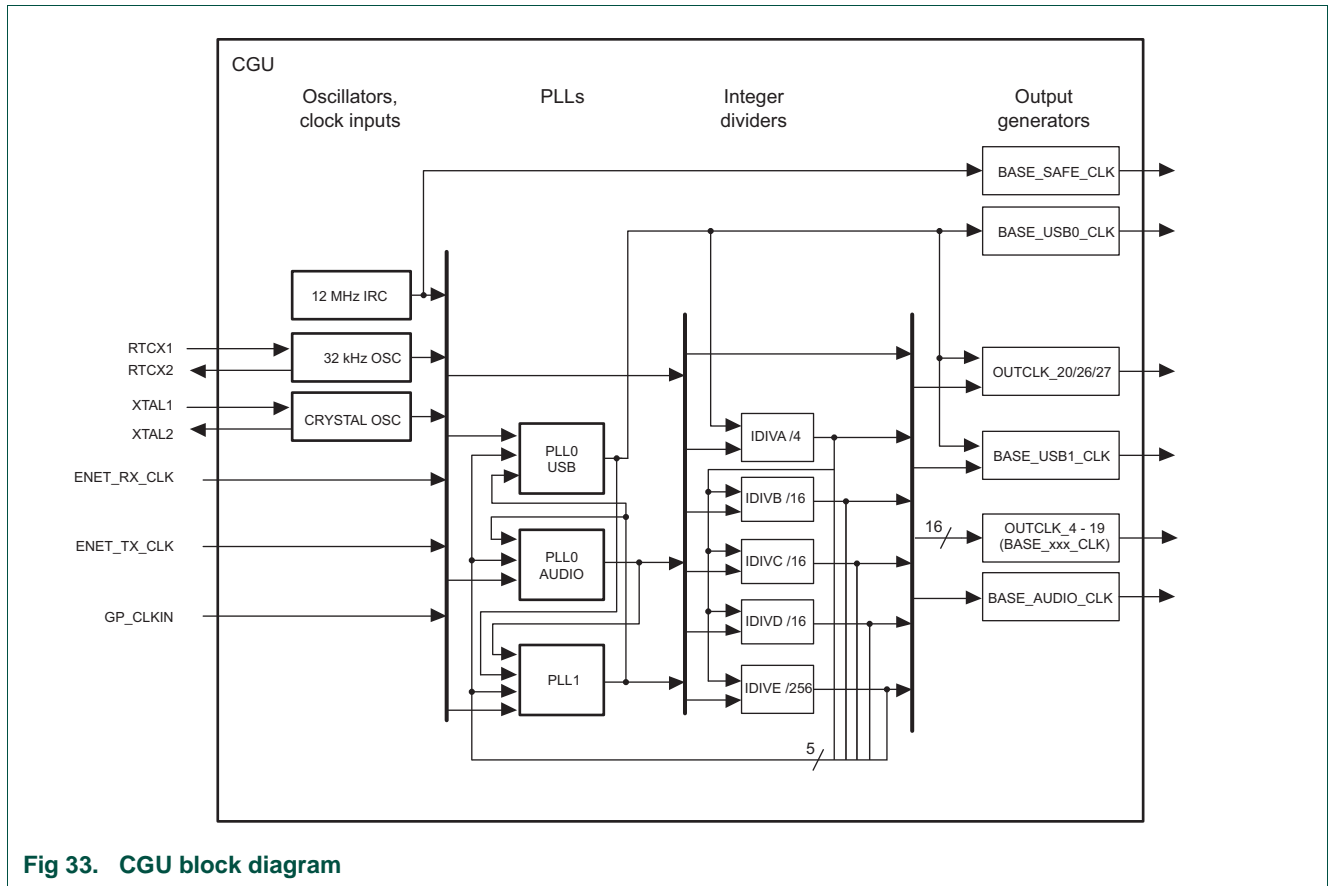

Fig 33. CGU block diagram

12.5 Pin description

Table 109. CGU pin description

Pin name/ function name	Direction	Description
XTAL1	I	Crystal oscillator input
XTAL2	O	Crystal oscillator output
RTCX1	I	RTC 32 kHz oscillator input
RTCX2	O	RTC 32 kHz oscillator output
GP_CLKIN	I	General purpose input clock
ENET_TX_CLK	I	Ethernet PHY transmit clock
ENET_RX_CLK	I	Ethernet PHY receive clock
CLKOUT	O	Clock output pin
CGU_OUT0	O	CGU spare output 0
CGU_OUT1	O	CGU spare output 1

12.6 Register description

Remark: The CGU is configured by the boot loader at reset and when waking up from Deep power-down to produce a 96 MHz clock using PLL1.

Table 110. Register overview: CGU (base address 0x4005 0000)

Name	Access	Address offset	Description	Reset value	Reset value after EMC, UART0/3 boot	Reset value after USB0/1 boot	Reference
-	R	0x000	Reserved	-	-	-	-
-	R	0x004	Reserved	-	-	-	-
-	R	0x008	Reserved	-	-	-	-
-	R	0x00C	Reserved	-	-	-	-
-	-	0x010	Reserved	-	-	-	-
FREQ_MON	R/W	0x014	Frequency monitor register	0	0	0	Table 111
XTAL_OSC_CTRL	R/W	0x018	Crystal oscillator control register	0x0000 0005	0x0100 0000	0 (USB0)	Table 112
PLL0USB_STAT	R	0x01C	PLL0USB status register	0x0100 0000	0x0100 0000	0x1 (USB0)	Table 113
PLL0USB_CTRL	R/W	0x020	PLL0USB control register	0x0100 0003	0x0100 0000	0x0600 0818 (USB0)	Table 114
PLL0USB_MDIV	R/W	0x024	PLL0USB M-divider register	0x05F8 5B6A	0x0100 0000	0x0196 7FFA (USB0)	Table 115
PLL0USB_NP_DIV	R/W	0x028	PLL0USB N/P-divider register	0x000B 1002	0x0100 0000	0x0030 2062 (USB0)	Table 116

Table 110. Register overview: CGU (base address 0x4005 0000) ...continued

Name	Access	Address offset	Description	Reset value	Reset value after EMC, UART0/3 boot	Reset value after USB0/1 boot	Reference
PLL0AUDIO_STAT	R	0x02C	PLL0AUDIO status register	0x0100 0000	0x0100 0000	0x0100 0000	Table 117
PLL0AUDIO_CTRL	R/W	0x030	PLL0AUDIO control register	0x0100 4003	0x0100 0000	0x0100 0000	Table 118
PLL0AUDIO_MDIV	R/W	0x034	PLL0AUDIO M-divider register	0x05F8 5B6A	0x0100 0000	0x0100 0000	Table 119
PLL0AUDIO_NP_DIV	R/W	0x038	PLL0AUDIO N/P-divider register	0x000B 1002	0x0100 0000	0x0100 0000	Table 120
PLL0AUDIO_FRAC	R/W	0x03C	PLL0AUDIO fractional divider register	0x0020 0000	0x0100 0000	0x0100 0000	Table 121
PLL1_STAT	R	0x040	PLL1 status register	0x0100 0000	0x1	0x1 (USB1)	Table 122
PLL1_CTRL	R/W	0x044	PLL1 control register	0x0100 0003	0x0117 0880	0x0117 0880 (USB1)	Table 123
IDIVA_CTRL	R/W	0x048	Integer divider A control register	0x0100 0000	0x0100 0000	0x0100 0000	Table 124
IDIVB_CTRL	R/W	0x04C	Integer divider B control register	0x0100 0000	0x0100 0000	0x0100 0000	Table 125
IDIVC_CTRL	R/W	0x050	Integer divider C control register	0x0100 0000	0x0900 0808	0x0900 0808	Table 125
IDIVD_CTRL	R/W	0x054	Integer divider D control register	0x0100 0000	0x0100 0000	0x0100 0000	Table 125
IDIVE_CTRL	R/W	0x058	Integer divider E control register	0x0100 0000	0x0100 0000	0x0100 0000	Table 126
BASE_SAFE_CLK	R	0x05C	Output stage 0 control register for base clock BASE_SAFE_CLK	0x0100 0000	0x0100 0000	0x0100 0000	Table 127
BASE_USB0_CLK	R/W	0x060	Output stage 1 control register for base clock BASE_USB0_CLK	0x0700 0000	0x0100 0000	0x0700 0800 (USB0)	Table 128
-	-	0x064	Reserved	-	-	-	-
BASE_USB1_CLK	R/W	0x068	Output stage 3 control register for base clock BASE_USB1_CLK	0x0100 0000	0x0100 0000	0x0100 0000	Table 129
BASE_M3_CLK	R/W	0x06C	Output stage 4 control register for base clock BASE_M3_CLK	0x0100 0000	0x0100 0000	0x0100 0000	Table 130
BASE_SPIFI_CLK	R/W	0x070	Output stage 5 control register for base clock BASE_SPIFI_CLK	0x0100 0000	0x0100 0000	0x0100 0000	Table 130
-	R/W	0x074	Reserved	-	-	-	-
BASE_PHY_RX_CLK	R/W	0x078	Output stage 7 control register for base clock BASE_PHY_RX_CLK	0x0100 0000	0x0100 0000	0x0100 0000	Table 130

Table 110. Register overview: CGU (base address 0x4005 0000) ...continued

Name	Access	Address offset	Description	Reset value	Reset value after EMC, UART0/3 boot	Reset value after USB0/1 boot	Reference
BASE_PHY_TX_CLK	R/W	0x07C	Output stage 8 control register for base clock BASE_PHY_TX_CLK	0x0100 0000	0x0100 0000	0x0100 0000	Table 130
BASE_APB1_CLK	R/W	0x080	Output stage 9 control register for base clock BASE_APB1_CLK	0x0100 0000	0x0100 0000	0x0100 0000	Table 130
BASE_APB3_CLK	R/W	0x084	Output stage 10 control register for base clock BASE_APB3_CLK	0x0100 0000	0x0100 0000	0x0100 0000	Table 130
BASE_LCD_CLK	R/W	0x088	Output stage 11 control register for base clock BASE_LCD_CLK	0x0100 0000	0x0100 0000	0x0100 0000	Table 130
-	R/W	0x08C	Reserved	-	-	-	-
BASE_SDIO_CLK	R/W	0x090	Output stage 13 control register for base clock BASE_SDIO_CLK	0x0100 0000	0x0100 0000	0x0100 0000	Table 130
BASE_SSP0_CLK	R/W	0x094	Output stage 14 control register for base clock BASE_SSP0_CLK	0x0100 0000	0x0100 0000	0x0100 0000	Table 130
BASE_SSP1_CLK	R/W	0x098	Output stage 15 control register for base clock BASE_SSP1_CLK	0x0100 0000	0x0100 0000	0x0100 0000	Table 130
BASE_UART0_CLK	R/W	0x09C	Output stage 16 control register for base clock BASE_UART0_CLK	0x0100 0000	0x0100 0000	0x0100 0000	Table 130
BASE_UART1_CLK	R/W	0x0A0	Output stage 17 control register for base clock BASE_UART1_CLK	0x0100 0000	0x0100 0000	0x0100 0000	Table 130
BASE_UART2_CLK	R/W	0x0A4	Output stage 18 control register for base clock BASE_UART2_CLK	0x0100 0000	0x0100 0000	0x0100 0000	Table 130
BASE_UART3_CLK	R/W	0x0A8	Output stage 19 control register for base clock BASE_UART3_CLK	0x0100 0000	0x0100 0000	0x0100 0000	Table 130
BASE_OUT_CLK	R/W	0x0AC	Output stage 20 control register for base clock BASE_OUT_CLK	0x0100 0000	0x0100 0000	0x0100 0000	Table 131
-	-	0x0B0 to 0x0BC	Reserved output stages	-	-	-	-

Table 110. Register overview: CGU (base address 0x4005 0000) ...continued

Name	Access	Address offset	Description	Reset value	Reset value after EMC, UART0/3 boot	Reset value after USB0/1 boot	Reference
BASE_AUDIO_CLK	R/W	0x0C0	Output stage 25 control register for base clock BASE_AUDIO_CLK	0x0100 0000	0x0100 0000	0x0100 0000	Table 132
BASE_CGU_OUT0_CLK	R/W	0x0C4	Output stage 26 control register for base clock BASE_CGU_OUT0_CLK	0x0100 0000	0x0100 0000	0x0100 0000	Table 133
BASE_CGU_OUT1_CLK	R/W	0x0C8	Output stage 27 control register for base clock BASE_CGU_OUT1_CLK	0x0100 0000	0x0100 0000	0x0100 0000	Table 133

12.6.1 Frequency monitor register

The CGU can report the relative frequency of any operating clock. The clock to be measured must be selected by software, while the fixed-frequency IRC clock *fref* is used as the reference frequency. A 14-bit counter then counts the number of cycles of the measured clock that occur during a user-defined number of reference-clock cycles. When the MEAS bit is set, the measured-clock counter is reset to 0 and counts up, while the 9-bit reference-clock counter is loaded with the value in RCNT and then counts down towards 0. When either counter reaches its terminal value both counters are disabled and the MEAS bit is reset to 0. The current values of the counters can then be read out and the selected frequency obtained by the following equation:

$$f_{selected} = \frac{FCNT}{RCNT} \times f_{ref}$$

Note that the accuracy of this measurement can be affected by several factors:

1. Quantization error is noticeable if the ratio between the two clocks is large (e.g. 100 kHz vs. 1 kHz), because one counter saturates while the other still has only a small count value.
2. Due to synchronization, the counters are not started and stopped at exactly the same time.
3. The measured frequency can only be to the same level of precision as the reference frequency.

Table 111. **FREQ_MON** register (**FREQ_MON**, address 0x4005 0014) bit description

Bit	Symbol	Value	Description	Reset value	Access
8:0	RCNT		9-bit reference clock-counter value	0	R/W
22:9	FCNT		14-bit selected clock-counter value	0	R

Table 111. FREQ_MON register (FREQ_MON, address 0x4005 0014) bit description
...continued

Bit	Symbol	Value	Description	Reset value	Access
23	MEAS		Measure frequency	0	R/W
		0	RCNT and FCNT disabled		
		1	Frequency counters started		
28:24	CLK_SEL		Clock-source selection for the clock to be measured. All other values are reserved.	0	R/W
		0x00	32 kHz oscillator (default)		
		0x01	IRC		
		0x02	ENET_RX_CLK		
		0x03	ENET_TX_CLK		
		0x04	GP_CLKIN		
		0x05	Reserved		
		0x06	Crystal oscillator		
		0x07	PLL0USB		
		0x08	PLL0AUDIO		
		0x09	PLL1		
		0x0A	Reserved		
0x0B	Reserved				
0x0C	IDIVA				
0x0D	IDIVB				
0x0E	IDIVC				
0x0F	IDIVD				
0x10	IDIVE				
31:29	-		Reserved	-	-

12.6.2 Crystal oscillator control register

The register XTAL_OSC_CONTROL contains the control bits for the crystal oscillator.

Table 112. XTAL_OSC_CTRL register (XTAL_OSC_CTRL, address 0x4005 0018) bit description

Bit	Symbol	Value	Description	Reset value	Access
0	ENABLE		Oscillator-pad enable. Do not change the BYPASS and ENABLE bits in one write-action: this will result in unstable device operation!	1	R/W
		0	Enable		
		1	Power-down (default)		

Table 112. XTAL_OSC_CTRL register (XTAL_OSC_CTRL, address 0x4005 0018) bit description

Bit	Symbol	Value	Description	Reset value	Access
1	BYPASS		Configure crystal operation or external-clock input pin XTAL1. Do not change the BYPASS and ENABLE bits in one write-action: this will result in unstable device operation!	0	R/W
		0	Operation with crystal connected (default).		
		1	Bypass mode. Use this mode when an external clock source is used instead of a crystal.		
2	HF		Select frequency range	1	R/W
		0	Oscillator low-frequency mode (crystal or external clock source 1 to 20 MHz). Between 15 MHz and 20 MHz, the state of the HF bit is don't care.		
		1	Oscillator high-frequency mode; crystal or external clock source 15 to 25 MHz. Between 15 MHz and 20 MHz, the state of the HF bit is don't care.		
31:3	-		Reserved	-	-

12.6.3 PLL0USB registers

The PLL0USB provides a dedicated clock to the High-speed USB0 interface.

See [Section 12.7.4.5](#) for instructions on how to set up the PLL0USB.

12.6.3.1 PLL0USB status register

Table 113. PLL0USB status register (PLL0USB_STAT, address 0x4005 001C) bit description

Bit	Symbol	Description	Reset value	Access
0	LOCK	PLL0 lock indicator	0	R
1	FR	PLL0 free running indicator	0	R
31:2	-	Reserved		-

12.6.3.2 PLL0USB control register

Table 114. PLL0USB control register (PLL0USB_CTRL, address 0x4005 0020) bit description

Bit	Symbol	Value	Description	Reset value	Access
0	PD		PLL0 power down	1	R/W
		0	PLL0 enabled		
		1	PLL0 powered down		
1	BYPASS		Input clock bypass control	1	R/W
		0	CCO clock sent to post-dividers. Use this in normal operation.		
		1	PLL0 input clock sent to post-dividers (default).		
2	DIRECTI		PLL0 direct input	0	R/W

Table 114. PLL0USB control register (PLL0USB_CTRL, address 0x4005 0020) bit description
...continued

Bit	Symbol	Value	Description	Reset value	Access
3	DIRECTO		PLL0 direct output	0	R/W
4	CLKEN		PLL0 clock enable	0	R/W
5	-		Reserved	-	-
6	FRM		Free running mode	0	R/W
7	-		Reserved	0	R/W
8	-		Reserved. Reads as zero. Do not write one to this register.	0	R/W
9	-		Reserved. Reads as zero. Do not write one to this register.	0	R/W
10	-		Reserved. Reads as zero. Do not write one to this register.	0	R/W
11	AUTOBLOCK		Block clock automatically during frequency change ^[1] .	0	R/W
		0	Autoblocking disabled		
		1	Autoblocking enabled		
23:12	-		Reserved	-	-
28:24	CLK_SEL		Clock source selection. All other values are reserved.	0x01	R/W
		0x00	32 kHz oscillator		
		0x01	IRC (default)		
		0x02	ENET_RX_CLK		
		0x03	ENET_TX_CLK		
		0x04	GP_CLKIN		
		0x06	Crystal oscillator		
		0x09	PLL1		
		0x0C	IDIVA		
		0x0D	IDIVB		
		0x0E	IDIVC		
		0x0F	IDIVD		
		0x10	IDIVE		
31:29	-		Reserved	-	-

[1] When the PLL0USB is enabled, set the AUTOBLOCK bit (bit 11). This bit re-synchronizes the clock output during frequency changes that prevents glitches when switching clock frequencies.

12.6.3.3 PLL0USB M-divider register

Remark: The PLL M-divider register does not use the direct binary representations of M directly. Instead, it uses an encoded version MDEC of M. The valid range for M is 1 to 2¹⁵. This value is encoded into a 17-bit MDEC value.

The relationship between M = msel and MDEC is expressed via the following code snippet. For specific examples see [Section 12.8.3](#) and [Section 12.8.4](#).

```
#define PLL0_MSEL_MAX (1<<15)
```

```

/* multiplier: compute mdec from msel */
unsigned mdec_new (unsigned msel) {
    unsigned x=0x4000, im;
    switch (msel) {
        case 0: return 0xFFFFFFFF;
        case 1: return 0x18003;
        case 2: return 0x10003;
        default:
            for (im = msel; im <= PLL0_MSEL_MAX; im++)
                x = ((x ^ x>>1) & 1) << 14 | x>>1 & 0xFFFF;
            return x;
    }
}

```

The values for SELP and SELI depend on the value for M = msel as expressed by the following code snippet (SELR = 0):

```

/* bandwidth: compute seli from msel */
unsigned anadeci_new (unsigned msel) {
    unsigned tmp;
    if (msel > 16384) return 1;
    if (msel > 8192) return 2;
    if (msel > 2048) return 4;
    if (msel >= 501) return 8;
    if (msel >= 60) {
        tmp=1024/(msel+9);
        return ( 1024 == ( tmp*(msel+9)) ) == 0 ? tmp*4 : (tmp+1)*4 ;
    }
    return (msel & 0x3c) + 4;
}

/* bandwidth: compute selp from msel */
unsigned anadecp_new (unsigned msel) {
    if (msel < 60) return (msel>>1) + 1;
    return 31;
}

```

Table 115. PLL0USB M-divider register (PLL0USB_MDIV, address 0x4005 0024) bit description

Bit	Symbol	Description	Reset value	Access
16:0	MDEC	Decoded M-divider coefficient value. Select values for the M-divider between 1 and 131071.	0x5B6A	R/W
21:17	SELP	Bandwidth select P value	11100	R/W
27:22	SELI	Bandwidth select I value	010111	R/W
31:28	SELR	Bandwidth select R value	0000	R/W

12.6.3.4 PLL0USB NP-divider register

Remark: The PLL NP-divider register does not use the direct binary representations of $N = nsel$ and $P = psel$ directly. Instead, it uses encoded versions NDEC and PDEC of N and P respectively.

- The valid range for $N = nsel$ is from 1 to 2^8 . This value is encoded into a 10-bit NDEC value. The relationship can be expressed through the following code snippet:

```
#define PLL0_NSEL_MAX (1<<8)
/* pre-divider: compute ndec from nsel */
unsigned ndec_new (unsigned nsel) {
    unsigned x=0x80, in;
    switch (nsel) {
        case 0: return 0xFFFFFFFF;
        case 1: return 0x302;
        case 2: return 0x202;
        default:for (in = nsel; in <= PLL0_NSEL_MAX; in++)
            x = ((x ^ x>>2 ^ x>>3 ^ x>>4) & 1) << 7 | x>>1 & 0xFF;
            return x;
    }
}
```

- The valid range for $P = psel$ is from 1 to 2^5 . This value is encoded into a 7-bit PDEC value. The relationship can be expressed through the following code snippet:

```
#define PLL0_PSEL_MAX (1<<5)
/* post-divider: compute pdec from psel */
unsigned pdec_new (unsigned psel) {
    unsigned x=0x10, ip;
    switch (psel) {
        case 0: return 0xFFFFFFFF;
        case 1: return 0x62;
        case 2: return 0x42;
        default:for (ip = psel; ip <= PLL0_PSEL_MAX; ip++)
            x = ((x ^ x>>2) & 1) << 4 | x>>1 & 0x3F;
            return x;
    }
}
```

For specific examples see [Section 12.8.3](#) and [Section 12.8.4](#).

Table 116. PLL0USB NP-divider register (PLL0USB_NP_DIV, address 0x4005 0028) bit description

Bit	Symbol	Description	Reset value	Access
6:0	PDEC	Decoded P-divider coefficient value	000 0010	R/W
11:7	-	Reserved	-	-
21:12	NDEC	Decoded N-divider coefficient value	1011 0001	R/W
31:22	-	Reserved	-	-

12.6.4 PLL0AUDIO registers

The PLL0AUDIO provides a wide range of frequencies for audio applications and can be connected to multiple base clocks. The PLL0AUDIO can be used with or without a fractional divider.

See [Section 12.7.4.5](#) for instructions on how to set up the PLL0.

12.6.4.1 PLL0AUDIO status register

Table 117. PLL0AUDIO status register (PLL0AUDIO_STAT, address 0x4005 002C) bit description

Bit	Symbol	Description	Reset value	Access
0	LOCK	PLL0 lock indicator	0	R
1	FR	PLL0 free running indicator	0	R
31:2	-	Reserved	-	-

12.6.4.2 PLL0AUDIO control register

Table 118. PLL0AUDIO control register (PLL0AUDIO_CTRL, address 0x4005 0030) bit description

Bit	Symbol	Value	Description	Reset value	Access
0	PD		PLL0 power down	1	R/W
		0	PLL0 enabled		
		1	PLL0 powered down		
1	BYPASS		Input clock bypass control	1	R/W
		0	CCO clock sent to post-dividers. Use this in normal operation.		
		1	PLL0 input clock sent to post-dividers (default).		
2	DIRECTI		PLL0 direct input	0	R/W
3	DIRECTO		PLL0 direct output	0	R/W
4	CLKEN		PLL0 clock enable	0	R/W
5	-		Reserved	-	-
6	FRM		Free running mode	0	R/W
7	-		Reserved	0	R/W
8	-		Reserved. Reads as zero. Do not write one to this register.	0	R/W
9	-		Reserved. Reads as zero. Do not write one to this register.	0	R/W
10	-		Reserved. Reads as zero. Do not write one to this register.	0	R/W
11	AUTOBLOCK		Block clock automatically during frequency change ^[1] .	0	R/W
		0	Autoblocking disabled		
		1	Autoblocking enabled		

Table 118. PLL0AUDIO control register (PLL0AUDIO_CTRL, address 0x4005 0030) bit description

...continued

Bit	Symbol	Value	Description	Reset value	Access
12	PLLFRACT_REQ		Fractional PLL word write request. Set this bit to 1 if the fractional divider is enabled in the SEL_EXT bit.	0	R/W
13	SEL_EXT		Select fractional divider.	0	R/W
		0	Enable fractional divider.		
		1	MDEC enabled. Fractional divider not used.		
14	MOD_PD		Sigma-Delta modulator power-down	1	R/W
		0	Sigma-Delta modulator enabled		
		1	Sigma-Delta modulator powered down		
23:15	-		Reserved	-	-
28:24	CLK_SEL		Clock source selection. All other values are reserved.	0x01	R/W
		0x00	32 kHz oscillator		
		0x01	IRC (default)		
		0x02	ENET_RX_CLK		
		0x03	ENET_TX_CLK		
		0x04	GP_CLKIN		
		0x06	Crystal oscillator		
		0x09	PLL1		
		0x0C	IDIVA		
		0x0D	IDIVB		
		0x0E	IDIVC		
		0x0F	IDIVD		
0x10	IDIVE				
31:29	-		Reserved	-	-

[1] When the PLL0AUDIO is enabled, set the AUTOBLOCK bit in the PLL0AUDIO_CTRL. This bit re-synchronizes the clock output during frequency changes that prevents glitches when switching clock frequencies.

12.6.4.3 PLL0AUDIO M-divider register

The PLL0AUDIO M-divider register can be set directly if the PLL0AUDIO is not used in fractional mode. If the fractional divider is enabled (see [Table 121](#)), then the fractional divider sets the MDEC value.

Remark: The PLL M-divider register does not use the direct binary representations of M directly. Instead, it uses an encoded version MDEC of M. The valid range for M is 1 to 2^{15} . This value is encoded into a 17-bit MDEC value.

The relationship between M and MDEC is expressed via the following code snippet. For specific examples see [Section 12.8.3](#) and [Section 12.8.4](#).

```
#define PLL0_MSEL_MAX (1<<15)
```

```

/* multiplier: compute mdec from msel */
unsigned mdec_new (unsigned msel) {
    unsigned x=0x4000, im;
    switch (msel) {
        case 0: return 0xFFFFFFFF;
        case 1: return 0x18003;
        case 2: return 0x10003;
        default:
            for (im = msel; im <= PLL0_MSEL_MAX; im++)
                x = ((x ^ x>>1) & 1) << 14 | x>>1 & 0xFFFF;
            return x;
    }
}

```

Remark: The values for SELP, SELI, and SELR are generated by the encoding block and need not be programmed explicitly.

Table 119. PLL0AUDIO M-divider register (PLL0AUDIO_MDIV, address 0x4005 0034) bit description

Bit	Symbol	Description	Reset value	Access
16:0	MDEC	Decoded M-divider coefficient value. Select values for the M-divider between 1 and 131071.	0x5B6A	R/W
31:17	-	Reserved	-	-

12.6.4.4 PLL0AUDIO NP-divider register

Remark: The PLL NP-divider register does not use the direct binary representations of N = nsel and P = psel directly. Instead, it uses encoded versions NDEC and PDEC of N and P respectively.

- The valid range for N = nsel is from 1 to 2⁸. This value is encoded into a 10-bit NDEC value. The relationship can be expressed through the following code snippet:

```

#define PLL0_NSEL_MAX (1<<8)
/* pre-divider: compute ndec from nsel */
unsigned ndec_new (unsigned nsel) {
    unsigned x=0x80, in;
    switch (nsel) {
        case 0: return 0xFFFFFFFF;
        case 1: return 0x302;
        case 2: return 0x202;
        default:for (in = nsel; in <= PLL0_NSEL_MAX; in++)
            x = ((x ^ x>>2 ^ x>>3 ^ x>>4) & 1) << 7 | x>>1 & 0xFF;
            return x;
    }
}

```

- The valid range for P = psel is from 1 to 2⁵. This value is encoded into a 7-bit PDEC value. The relationship can be expressed through the following code snippet:

```

#define PLL0_PSEL_MAX (1<<5)
/* post-divider: compute pdec from psel */
unsigned pdec_new (unsigned psel) {

```



```

unsigned x=0x10, ip;
switch (psel) {
    case 0: return 0xFFFFFFFF;
    case 1: return 0x62;
    case 2: return 0x42;
    default:for (ip = psel; ip <= PLL0_PSEL_MAX; ip++)
                x = ((x ^ x>>2) & 1) << 4 | x>>1 & 0x3F;
                return x;
}
}

```

Table 120. PLL0 AUDIO NP-divider register (PLL0AUDIO_NP_DIV, address 0x4005 0038) bit description

Bit	Symbol	Description	Reset value	Access
6:0	PDEC	Decoded P-divider coefficient value	000 0010	R/W
11:7	-	Reserved	-	-
21:12	NDEC	Decoded N-divider coefficient value	1011 0001	R/W
31:22	-	Reserved	-	-

12.6.4.5 PLL0AUDIO fractional divider register

When the fractional divider is active, the sigma-delta modulator block generates divider values M and M+1 in the correct proportion so that an average division ratio of M+K/L is realized where 0<=K<=L and M, K, and L are integer values. M is determined by the integer part of the PLLFRACT_CTRL register (PLLFRACT[21:15]) and K is determined by the fractional part of the PLLFRACT_CTRL register (PLLFRACT[14:0]). Consecutive M and M+1 values are then further encoded into appropriate MDEC values before being presented as input to the M-divider.

Table 121. PLL0AUDIO fractional divider register (PLL0AUDIO_FRAC, address 0x4005 003C) bit description

Bit	Symbol	Description	Reset value	Access
21:0	PLLFRACT_CTRL	PLL fractional divider control word	000 0000	R/W
31:22	-	Reserved	-	-

12.6.5 PLL1 registers

The PLL1 is used for the core and all peripheral blocks.

12.6.5.1 PLL1 status register

Table 122. PLL1 status register (PLL1_STAT, address 0x4005 0040) bit description

Bit	Symbol	Description	Reset value	Access
0	LOCK	PLL1 lock indicator	0	R
31:1	-	Reserved	-	-

12.6.5.2 PLL1 control register

Table 123. PLL1_CTRL register (PLL1_CTRL, address 0x4005 0044) bit description

Bit	Symbol	Value	Description	Reset value	Access
0	PD		PLL1 power down	1	R/W
		0	PLL1 enabled		
		1	PLL1 powered down		
1	BYPASS		Input clock bypass control	1	R/W
		0	CCO clock sent to post-dividers. Use for normal operation.		
		1	PLL1 input clock sent to post-dividers (default).		
2	-		Reserved. Do not write one to this bit.	0	R/W
5:3	-		Reserved. Do not write one to these bits.	-	-
6	FBSEL		PLL feedback select (see Figure 36 “PLL1 block diagram”).	0	R/W
		0	CCO output is used as feedback divider input clock.		
		1	PLL output clock (clkout) is used as feedback divider input clock. Use for normal operation.		
7	DIRECT		PLL direct CCO output	0	R/W
		0	Disabled		
		1	Enabled		
9:8	PSEL		Post-divider division ratio P. The P-divider applied by the PLL is 2xP.	01	R/W
		0x0	P = 1		
		0x1	P = 2 (default)		
		0x2	P = 4		
		0x3	P = 8		
10	-		Reserved	-	-
11	AUTOBLOCK		Block clock automatically during frequency change ^[1] .	0	R/W
		0	Autoblocking disabled		
		1	Autoblocking enabled		
13:12	NSEL		Pre-divider division ratio (N)	10	R/W
		0x0	1		
		0x1	2		
		0x2	3 (default)		
		0x3	4		
15:14	-		Reserved	-	-

Table 123. PLL1_CTRL register (PLL1_CTRL, address 0x4005 0044) bit description
...continued

Bit	Symbol	Value	Description	Reset value	Access
23:16	MSEL		Feedback-divider division ratio (M) 00000000 = 1 00000001 = 2 ... 11111111 = 256	11000	R/W
28:24	CLK_SEL		Clock-source selection.	0x01	R/W
		0x00	32 kHz oscillator		
		0x01	IRC (default)		
		0x02	ENET_RX_CLK		
		0x03	ENET_TX_CLK		
		0x04	GP_CLKIN		
		0x05	Reserved		
		0x06	Crystal oscillator		
		0x07	PLL0USB		
		0x08	PLL0AUDIO		
		0x09	Reserved		
		0x0A	Reserved		
		0x0C	IDIVA		
		0x0D	IDIVB		
		0x0E	IDIVC		
		0x0F	IDIVD		
		0x10	IDIVE		
31:29	-		Reserved	-	-

[1] When the PLL1 is enabled, set the AUTOBLOCK bit in the PLL1_CTRL register to 1. This bit re-synchronizes the clock output during frequency changes that prevents glitches when switching clock frequencies.

12.6.6 Integer divider register A

Table 124. IDIVA control register (IDIVA_CTRL, address 0x4005 0048) bit description

Bit	Symbol	Value	Description	Reset value	Access
0	PD		Integer divider A power down	0	R/W
		0	IDIVA enabled (default)		
		1	power-down		
1	-		Reserved	-	-

Table 124. IDIVA control register (IDIVA_CTRL, address 0x4005 0048) bit description
...continued

Bit	Symbol	Value	Description	Reset value	Access
3:2	IDIV		Integer divider A divider values (1/(IDIV + 1))	00	R/W
		0x0	1 (default)		
		0x1	2		
		0x2	3		
		0x3	4		
10:4	-		Reserved	-	-
11	AUTOBLOCK		Block clock automatically during frequency change	0	R/W
		0	Autoblocking disabled		
		1	Autoblocking enabled		
23:12	-		Reserved	-	-
28:24	CLK_SEL		Clock source selection. All other values are reserved.	0x01	R/W
		0x00	32 kHz oscillator		
		0x01	IRC (default)		
		0x02	ENET_RX_CLK		
		0x03	ENET_TX_CLK		
		0x04	GP_CLKIN		
		0x06	Crystal oscillator		
		0x07	PLL0USB		
		0x08	PLL0AUDIO		
		0x09	PLL1		
31:29	-		Reserved	-	-

12.6.7 Integer divider register B, C, D

Table 125. IDIVB/C/D control registers (IDIVB_CTRL, address 0x4005 004C; IDIVC_CTRL, address 0x4005 0050; IDIVD_CTRL, address 0x4005 0054) bit description

Bit	Symbol	Value	Description	Reset value	Access
0	PD		Integer divider power down	0	R/W
		0	IDIV enabled (default)		
		1	power-down		
1	-		Reserved	-	-
5:2	IDIV		Integer divider B, C, D divider values (1/(IDIV + 1))	0000	R/W
			0000 = 1 (default)		
			0001 = 2		
			...		
			1111 = 16		
10:6	-		Reserved	-	-

Table 125. IDIVB/C/D control registers (IDIVB_CTRL, address 0x4005 004C; IDIVC_CTRL, address 0x4005 0050; IDIVD_CTRL, address 0x4005 0054) bit description

Bit	Symbol	Value	Description	Reset value	Access
11	AUTOBLOCK		Block clock automatically during frequency change	0	R/W
		0	Autoblocking disabled		
		1	Autoblocking enabled		
23:12	-		Reserved	-	-
28:24	CLK_SEL		Clock-source selection. All other values are reserved.	0x01	R/W
		0x00	32 kHz oscillator		
		0x01	IRC (default)		
		0x02	ENET_RX_CLK		
		0x03	ENET_TX_CLK		
		0x04	GP_CLKIN		
		0x06	Crystal oscillator		
		0x08	PLL0AUDIO		
		0x09	PLL1		
0x0C	IDIVA				
31:29	-		Reserved	-	-

12.6.8 Integer divider register E

Table 126. IDIVE control register (IDIVE_CTRL, address 0x4005 0058) bit description

Bit	Symbol	Value	Description	Reset value	Access
0	PD		Integer divider power down	0	R/W
		0	IDIV enabled (default)		
		1	power-down		
1	-		Reserved	-	-
9:2	IDIV		Integer divider E divider values (1/(IDIV + 1)) 00000000 = 1 (default) 00000001 = 2 ... 11111111 = 256	00000000	R/W
10	-		Reserved	-	-
11	AUTOBLOCK		Block clock automatically during frequency change	0	R/W
		0	Autoblocking disabled		
		1	Autoblocking enabled		
23:12	-		Reserved	-	-

Table 126. IDIVE control register (IDIVE_CTRL, address 0x4005 0058) bit description

Bit	Symbol	Value	Description	Reset value	Access
28:24	CLK_SEL		Clock-source selection. All other values are reserved.	0x01	R/W
		0x00	32 kHz oscillator		
		0x01	IRC (default)		
		0x02	ENET_RX_CLK		
		0x03	ENET_TX_CLK		
		0x04	GP_CLKIN		
		0x06	Crystal oscillator		
		0x08	PLL0AUDIO		
		0x09	PLL1		
		0x0C	IDIVA		
31:29	-		Reserved	-	-

12.6.9 BASE_SAFE_CLK control register

This register controls the BASE_SAFE_CLK to the watchdog oscillator. The only possible clock source for this base clock is the IRC.

Table 127. BASE_SAFE_CLK control register (BASE_SAFE_CLK, address 0x4005 005C) bit description

Bit	Symbol	Value	Description	Reset value	Access
0	PD		Output stage power down	0	R
		0	Output stage enabled (default)		
		1	power-down		
10:1	-		Reserved	-	-
11	AUTOBLOCK		Block clock automatically during frequency change	0	R
		0	Autoblocking disabled		
		1	Autoblocking enabled		
23:12	-		Reserved	-	-
28:24	CLK_SEL		Clock source selection. All other values are reserved.	0x01	R
		0x01	IRC (default)		
31:29	-		Reserved	-	-

12.6.10 BASE_USB0_CLK control register

This register controls the BASE_USB0_CLK to the High-speed USB0. The only possible clock source for this base clock is the PLL0USB output.

Table 128. BASE_USB0_CLK control register (BASE_USB0_CLK, address 0x4005 0060) bit description

Bit	Symbol	Value	Description	Reset value	Access
0	PD		Output stage power down	0	R/W
		0	Output stage enabled (default)		
		1	power-down		
10:1	-		Reserved	-	-
11	AUTOBLOCK		Block clock automatically during frequency change	0	R/W
		0	Autoblocking disabled		
		1	Autoblocking enabled		
23:12	-		Reserved	-	-
28:24	CLK_SEL		Clock-source selection.	0x07	R/W
		0x07	PLL0USB (default)		
31:29	-		Reserved	-	-

12.6.11 BASE_USB1_CLK control register

These registers control base clock 3 (USB1).

Table 129. BASE_USB1_CLK control register (BASE_USB1_CLK, address 0x4005 0068) bit description

Bit	Symbol	Value	Description	Reset value	Access
0	PD		Output stage power down	0	R/W
		0	Output stage enabled (default)		
		1	power-down		
10:1	-		Reserved	-	-
11	AUTOBLOCK		Block clock automatically during frequency change	0	R/W
		0	Autoblocking disabled		
		1	Autoblocking enabled		
23:12	-		Reserved	-	-

Table 129. BASE_USB1_CLK control register (BASE_USB1_CLK, address 0x4005 0068) bit description ...continued

Bit	Symbol	Value	Description	Reset value	Access
28:24	CLK_SEL		Clock source selection. All other values are reserved.	0x01	R/W
		0x00	32 kHz oscillator		
		0x01	IRC (default)		
		0x02	ENET_RX_CLK		
		0x03	ENET_TX_CLK		
		0x04	GP_CLKIN		
		0x06	Crystal oscillator		
		0x07	PLL0USB		
		0x08	PLL0AUDIO		
		0x09	PLL1		
		0x0C	IDIVA		
		0x0D	IDIVB		
0x0E	IDIVC				
0x0F	IDIVD				
0x10	IDIVE				
31:29	-		Reserved	-	-

12.6.12 BASE_M3_CLK to BASE_UART3_CLK control registers

These registers control base clocks 4 to 19.

Table 130. BASE_M3_CLK to BASE_UART3_CLK control registers (BASE_M3_CLK to BASE_UART3_CLK, address 0x4005 006C to 0x4005 00A8) bit description

Bit	Symbol	Value	Description	Reset value	Access
0	PD		Output stage power down	0	R/W
		0	Output stage enabled (default)		
		1	power-down		
10:1	-		Reserved	-	-
11	AUTOBLOCK		Block clock automatically during frequency change	0	R/W
		0	Autoblocking disabled		
		1	Autoblocking enabled		
23:12	-		Reserved	-	-

Table 130. BASE_M3_CLK to BASE_UART3_CLK control registers (BASE_M3_CLK to BASE_UART3_CLK, address 0x4005 006C to 0x4005 00A8) bit description

Bit	Symbol	Value	Description	Reset value	Access
28:24	CLK_SEL		Clock source selection. All other values are reserved.	0x01	R/W
		0x00	32 kHz oscillator		
		0x01	IRC (default)		
		0x02	ENET_RX_CLK		
		0x03	ENET_TX_CLK		
		0x04	GP_CLKIN		
		0x06	Crystal oscillator		
		0x08	PLL0AUDIO		
		0x09	PLL1		
		0x0C	IDIVA		
		0x0D	IDIVB		
		0x0E	IDIVC		
0x0F	IDIVD				
0x10	IDIVE				
31:29	-		Reserved	-	-

12.6.13 BASE_OUT_CLK register

This register controls the clock output to the CLKOUT pin. All clock generator outputs can be monitored through this pin.

Table 131. BASE_OUT_CLK control register (BASE_OUT_CLK, addresses 0x4005 00AC) bit description

Bit	Symbol	Value	Description	Reset value	Access
0	PD		Output stage power down	0	R/W
		0	Output stage enabled (default)		
		1	power-down		
10:1	-		Reserved	-	-
11	AUTOBLOCK		Block clock automatically during frequency change	0	R/W
		0	Autoblocking disabled		
		1	Autoblocking enabled		
23:12	-		Reserved	-	-

Table 131. BASE_OUT_CLK control register (BASE_OUT_CLK, addresses 0x4005 00AC) bit description ...continued

Bit	Symbol	Value	Description	Reset value	Access
28:24	CLK_SEL		Clock-source selection.	0x01	R/W
		0x00	32 kHz oscillator		
		0x01	IRC (default)		
		0x02	ENET_RX_CLK		
		0x03	ENET_TX_CLK		
		0x04	GP_CLKIN		
		0x05	Reserved		
		0x06	Crystal oscillator		
		0x07	PLL0USB		
		0x08	PLL0AUDIO		
		0x09	PLL1		
		0x0C	IDIVA		
0x0D	IDIVB				
0x0E	IDIVC				
0x0F	IDIVD				
0x10	IDIVE				
31:29	-		Reserved	-	-

12.6.14 BASE_AUDIO_CLK register

Table 132. BASE_AUDIO_CLK control register (BASE_AUDIO_CLK, addresses 0x4005 00C0) bit description

Bit	Symbol	Value	Description	Reset value	Access
0	PD		Output stage power down	0	R/W
		0	Output stage enabled (default)		
		1	power-down		
10:1	-		Reserved	-	-
11	AUTOBLOCK		Block clock automatically during frequency change	0	R/W
		0	Autoblocking disabled		
		1	Autoblocking enabled		
23:12	-		Reserved	-	-

Table 132. BASE_AUDIO_CLK control register (BASE_AUDIO_CLK, addresses 0x4005 00C0) bit description ...continued

Bit	Symbol	Value	Description	Reset value	Access
28:24	CLK_SEL		Clock-source selection.	0x01	R/W
		0x00	32 kHz oscillator		
		0x01	IRC (default)		
		0x02	ENET_RX_CLK		
		0x03	ENET_TX_CLK		
		0x04	GP_CLKIN		
		0x05	Reserved		
		0x06	Crystal oscillator		
		0x07	Reserved		
		0x08	PLL0AUDIO		
		0x09	PLL1		
	0x0C	IDIVA			
	0x0D	IDIVB			
	0x0E	IDIVC			
	0x0F	IDIVD			
	0x10	IDIVE			
31:29	-		Reserved	-	-

12.6.15 BASE_CGU_OUT0_CLK to BASE_CGU_OUT1_CLK register

This register controls the clock output to the spare CGU outputs pins CGU_OUT0 and CGU_OUT1. All clock generator outputs can be monitored through this pin.

Table 133. BASE_CGU_OUT0_CLK to BASE_CGU_OUT1_CLK control register (BASE_CGU_OUT0_CLK to BASE_CGU_OUT1_CLK, addresses 0x4005 00C4 to 0x4005 00C8) bit description

Bit	Symbol	Value	Description	Reset value	Access
0	PD		Output stage power down	0	R/W
		0	Output stage enabled (default)		
		1	power-down		
10:1	-		Reserved	-	-
11	AUTOBLOCK		Block clock automatically during frequency change	0	R/W
		0	Autoblocking disabled		
		1	Autoblocking enabled		
23:12	-		Reserved	-	-

Table 133. BASE_CGU_OUT0_CLK to BASE_CGU_OUT1_CLK control register (BASE_CGU_OUT0_CLK to BASE_CGU_OUT1_CLK, addresses 0x4005 00C4 to 0x4005 00C8) bit description ...continued

Bit	Symbol	Value	Description	Reset value	Access
28:24	CLK_SEL		Clock-source selection.	0x01	R/W
		0x00	32 kHz oscillator		
		0x01	IRC (default)		
		0x02	ENET_RX_CLK		
		0x03	ENET_TX_CLK		
		0x04	GP_CLKIN		
		0x05	Reserved		
		0x06	Crystal oscillator		
		0x07	PLL0USB		
		0x08	PLL0AUDIO		
		0x09	PLL1		
		0x0C	IDIVA		
		0x0D	IDIVB		
		0x0E	IDIVC		
		0x0F	IDIVD		
		0x10	IDIVE		
31:29	-		Reserved	-	-

12.7 Functional description

12.7.1 32 kHz oscillator

The 32 kHz oscillator output is controlled by the CREG block (see [Table 88](#)). The RTC and the Alarm timer are connected directly to the 32 kHz oscillator.

12.7.2 IRC

The IRC is a trimmed 12 MHz internal oscillator. Although the IRC is part of the CGU, the CGU has no control over this clock source. The IRC is put into power down depending on the power saving mode.

12.7.3 Crystal oscillator

The crystal oscillator is controlled by the XTAL_OSC_CTRL register in the CGU (see [Table 112](#)).

12.7.4 PLL0 (PLL0USB and PLL0AUDIO)

The PLL blocks of the PLL0USB and PLL0AUDIO are identical. The PLL0AUDIO supports an additional fractional divider to obtain more PLL frequencies with higher accuracy for audio applications.

12.7.4.1 Features

- Input frequency: 14 kHz to 150 MHz. The input from an external crystal is limited to 25 MHz.
- CCO frequency: 275 MHz to 550 MHz.
- Output clock range: 4.3 MHz to 550 MHz.
- Programmable dividers:
 - Pre-divider N (N, 1 to 2^8)
 - Feedback-divider $2 \times M$ (M, 1 to 2^{15})
 - Post-divider $P \times 2$ (P, 1 to 2^5).
- Programmable bandwidth (integrating action, proportional action, high frequency pole).
- On-the-fly adjustment of the clock possible (dividers with handshake control).
- Positive edge clocking.
- Frequency limiter to avoid hang-up of the PLL.
- Lock detector.
- Power-down mode.
- Free running mode

Remark: Both PLL0 blocks are functionally identical. The PLL0 for audio applications (PLL0 for audio) supports an additional fractional divider stage (see [Section 12.7.5](#)).

12.7.4.2 PLL0 description

The block diagram of the PLL0 is shown in [Figure 34](#). The clock input has to be fed to pin `clk_in`. Pin `clk_out` is the PLL0 clock output. The analog part of the PLL consists of a Phase Frequency Detector (PFD), filter and a Current Controlled Oscillator (CCO). The PFD has two inputs, a reference input from the (divided) external clock and one input from the divided CCO output clock. The PFD compares the phase/frequency of these input signals and generates a control signal if they don't match. This control signal is fed to a filter which drives the CCO.

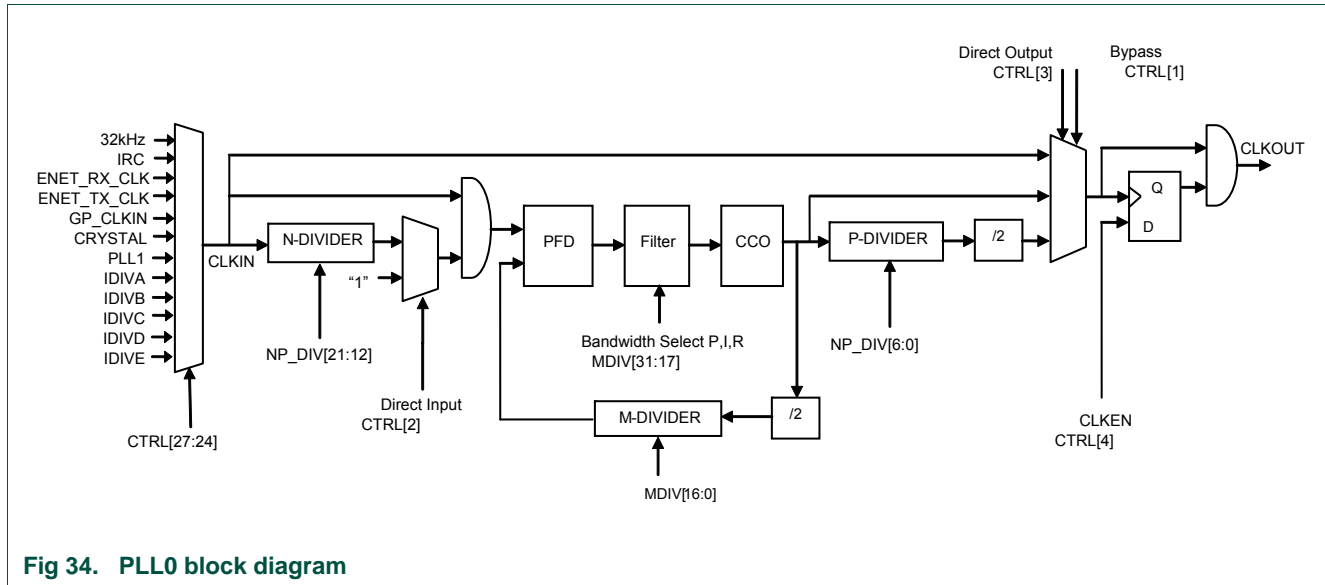

Fig 34. PLL0 block diagram

The PLL contains three programmable dividers: pre-divider (N), feedback-divider (M) and post-divider (P). The PLL contains a lock detector which measures the phase difference between the rising edges of the input and feedback clocks. Only when this difference is smaller than the so called “lock criterion” for more than seven consecutive input clock periods, the lock output switches from low to high. A single too large phase difference immediately resets the counter and causes the lock signal to drop (if it was high). Requiring seven phase measurements in a row to be below a certain figure ensures that the lock detector will not indicate lock until both the phase and frequency of the input and feedback clocks are very well aligned. This effectively prevents false lock indications, and thus ensures a glitch free lock signal.

To avoid frequency hang-up the PLL contains a frequency limiter. This feature is built in to prevent the CCO from running too fast, this can occur if e.g. a wrong feedback-divider (M) ratio is applied to the PLL.

Remark: The PLL0 does not use the direct binary representations of M, N, and P directly. Instead, encoded versions MDEC, NDEC, and PDEC of M, N, and P respectively.

See [Section 12.6.3.3](#) and [Section 12.6.3.4](#) for how to obtain the encoded values for M, N, and P.

12.7.4.3 Use of PLL0 operating modes

Table 134. PLL0 operating modes

PLL0_Mode bit settings:						
Mode	PD	CLKEN	BYPASS	DIRECTI	DIRECTO	FRM
1: Normal	0	1	0	1/0	1/0	0
3: Power Down	1	x	x	x	x	x

12.7.4.3.1 Normal Mode

Mode 1 is the normal operating mode.

The pre- and post-divider can be selected as follows:

- mode 1a: Normal operating mode without post-divider and without pre-divider
- mode 1b: Normal operating mode with post-divider and without pre-divider
- mode 1c: Normal operating mode without post-divider and with pre-divider
- mode 1d: Normal operating mode with post-divider and with pre-divider

To get at the output of the PLL (clkout) the best phase-noise and jitter performance, the highest possible reference clock (clkref) at the PFD has to be used. Therefore mode 1a and 1b are recommended, when it is possible to make the right output frequency without pre-divider.

By using the post-divider the clock at the output of the PLL (clkout) the divider ratio is always even because the divide-by-2 divider after the post-divider.

Table 135. DIRECTL and DIRECTO bit settings in HP0/1_Mode register

Mode	DIRECTI	DIRECTO
1a	1	1
1b	1	0
1c	0	1
1d	0	0

12.7.4.3.2 Mode 1a: Normal operating mode without post-divider and without pre-divider

In normal operating mode 1a the post-divider and pre-divider are bypassed. The operating frequencies are:

$$F_{out} = F_{cco} = 2 \times M \times F_{in} \wedge (275 \text{ MHz} \leq F_{cco} \leq 550 \text{ MHz}, 4 \text{ kHz} \leq F_{in} \leq 150 \text{ MHz})$$

The feedback divider ratio is programmable:

- Feedback-divider M (M, 1 to 2^{15})

12.7.4.3.3 Mode 1b: Normal operating mode with post-divider and without pre-divider

In normal operating mode 1b the pre-divider is bypassed. The operating frequencies are:

$$F_{out} = F_{cco} / (2 \times P) = (M / P) \times F_{in} \wedge (275 \text{ MHz} \leq F_{cco} \leq 550 \text{ MHz}, 4 \text{ kHz} \leq F_{in} \leq 150 \text{ MHz})$$

The divider ratios are programmable:

- Feedback-divider M (M, 1 to 2^{15})
- Post-divider P (P, 1 to 32)

12.7.4.3.4 Mode 1c: Normal operating mode without post-divider and with pre-divider

In normal operating mode 1c the post-divider with divide-by-2 divider is bypassed. The operating frequencies are:

$$F_{out} = F_{cco} = 2 \times M \times F_{in} / N \wedge (275 \text{ MHz} \leq F_{cco} \leq 550 \text{ MHz}, 4 \text{ kHz} \leq F_{in}/N \leq 150 \text{ MHz})$$

The divider ratios are programmable:

- Pre-divider N (N, 1 to 256)
- Feedback-divider M (M, 1 to 2^{15})

12.7.4.3.5 Mode 1d: Normal operating mode with post-divider and with pre-divider

In normal operating mode 1d none of the dividers are bypassed. The operating frequencies are:

$$F_{out} = F_{cco} / (2 \times P) = M \times F_{in} / (N \times P) \wedge (275 \text{ MHz} \leq F_{cco} \leq 550 \text{ MHz}, 4 \text{ kHz} \leq F_{in}/N \leq 150 \text{ MHz})$$

The divider ratios are programmable:

- Pre-divider N (N, 1 to 256)
- Feedback-divider M (M, 1 to 2^{15})
- Post-divider P (P, 1 to 32)

12.7.4.3.6 Mode 3: Power down mode (pd)

In this mode (pd = '1'), the oscillator will be stopped, the lock output will be made low, and the internal current reference will be turned off. During pd it is possible to load new divider ratios at the input buses (msel, psel, nsel). Power-down mode is ended by making pd low, causing the PLL to start up. The lock signal will be made high once the PLL has regained lock on the input clock.

12.7.4.4 Settings for USB0

[Table 136](#) shows the divider settings used for configuring an output frequency F_{out} of 480 MHz for USB0.

12.7.4.5 Usage notes

In order to set up the PLL0, follow these steps:

1. Power down the PLL0 by setting bit 0 in the PLL0 control register (PLL0USB_CTRL or PLL0AUDIO_CTRL) to 1. This step is only needed if the PLL0 is currently enabled.
2. Configure the PLL0 m, n, and p divider values in the PLL0_M and PLL0_NP registers.
3. Power up the PLL0 by setting bit 0 in the PLL0 control register (PLL0USB_CTRL or PLL0AUDIO_CTRL) to 0.
4. Wait for the PLL0 to lock by monitoring the LOCK bit in the PLL0_STAT register.
5. Enable the PLL0 clock output in the PLL0_CTRL register.

Remark: You can change the PLL0 settings while the PLL0 is running when you need to configure the PLL0 for high output frequencies (see [Section 12.2.1](#)).

12.7.5 Fractional divider for PLL0AUDIO

The PLL0 for audio applications (PLL0AUDIO) includes an additional fractional divider. The SEL_EXT bit in the PLL0AUDIO control register determines whether the fractional divider is used (SEL_EXT=0) or bypassed (SEL_EXT=1). In the latter case, PLL0AUDIO operates exactly as PLL0USB and the MDEC value is used directly to control the feedback divider.

When the fractional divider is active, the sigma-delta modulator block generates divider values M and M+1 in the correct proportion so that an average division ratio of $M+K/L$ is realized where $0 \leq K \leq L$ and M, K, and L are integer values. M is determined by the integer part of the PLLFRACT_CTRL register (PLLFRACT[21:15]) and K is determined by

the fractional part of the PLLFRACT_CTRL register (PLLFRACT[14:0]). Consecutive M and M+1 values are then further encoded into appropriate MENC values before being presented as input to the M-divider.

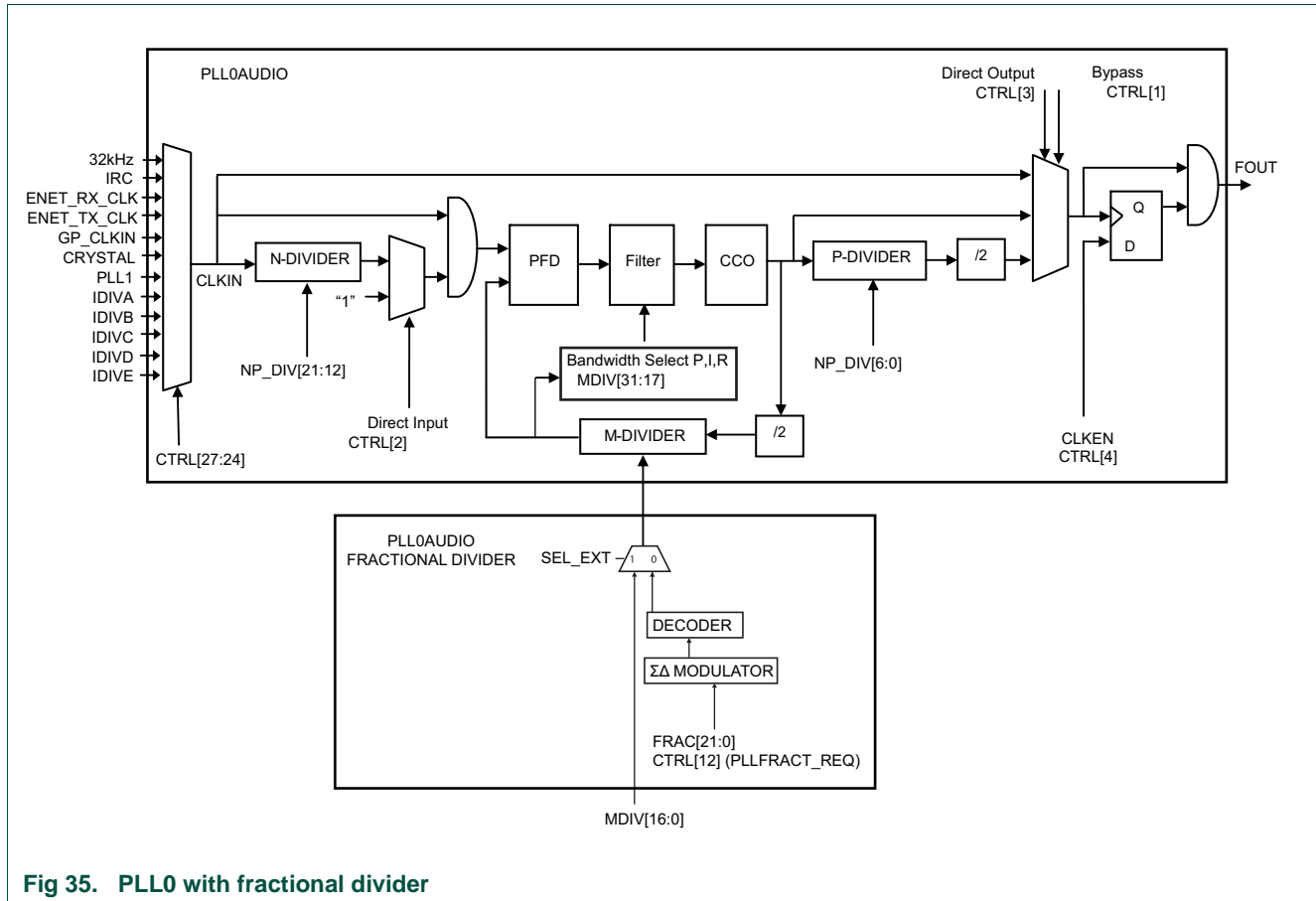

Fig 35. PLL0 with fractional divider

12.7.6 PLL1

12.7.6.1 Features

- 1 MHz to 50 MHz input frequency. The input from an external crystal is limited to 25 MHz.
- 9.75 MHz to 320 MHz selectable output frequency with 50% duty cycle.
- 156 MHz to 320 MHz Current Controlled Oscillator (CCO) frequency.
- Power-down mode.
- Lock detector.

12.7.6.2 PLL1 description

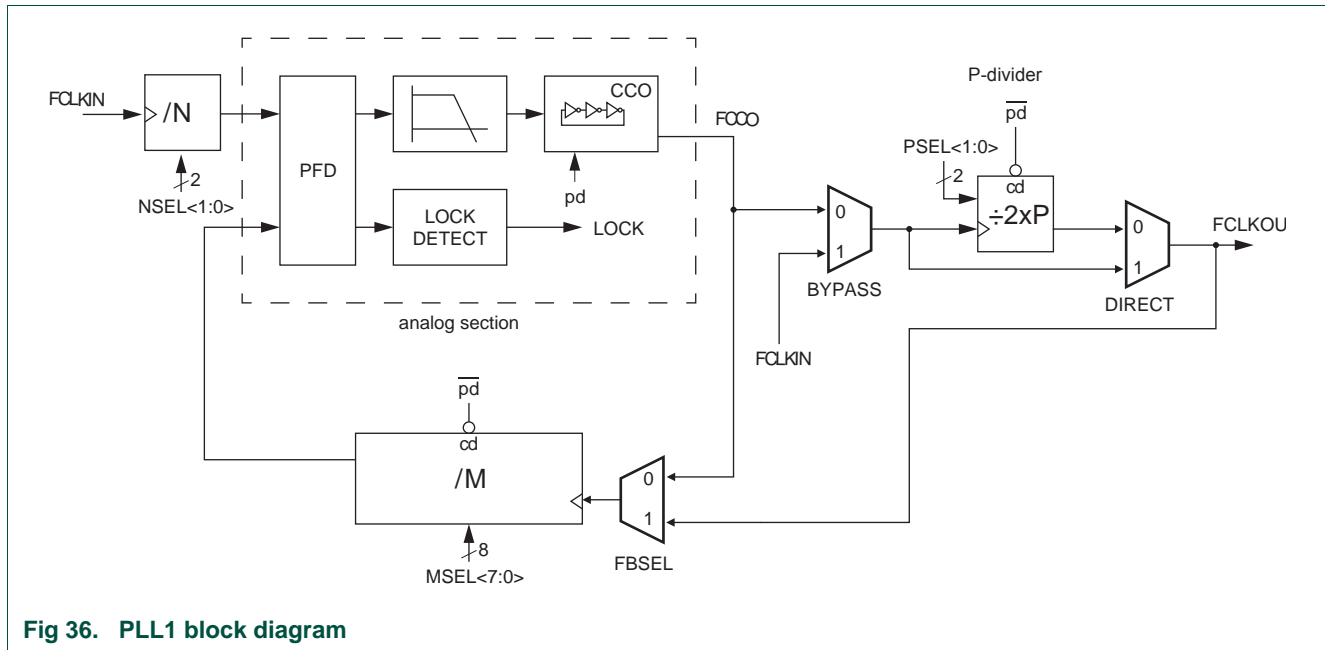

Fig 36. PLL1 block diagram

The block diagram of this PLL is shown in [Figure 36](#). The input frequency range is 10 MHz to 25 MHz. The input clock is fed directly to the Phase-Frequency Detector (PFD). This block compares the phase and frequency of its inputs, and generates a control signal when phase and/ or frequency do not match. The loop filter filters these control signals and drives the current controlled oscillator (CCO), which generates the main clock. The CCO frequency range is 156 MHz to 320 MHz. These clocks are either divided by $2 \times P$ by the programmable post divider to create the output clocks, or are sent directly to the outputs. The main output clock is then divided by M by the programmable feedback divider to generate the feedback clock. The output signal of the phase-frequency detector is also monitored by the lock detector, to signal when the PLL has locked on to the input clock.

12.7.6.3 Lock detector

The lock detector measures the phase difference between the rising edges of the input and feedback clocks. Only when this difference is smaller than the so called “lock criterion” for more than eight consecutive input clock periods, the lock output switches from low to high. A single too large phase difference immediately resets the counter and causes the lock signal to drop (if it was high). Requiring eight phase measurements in a row to be below a certain figure ensures that the lock detector will not indicate lock until both the phase and frequency of the input and feedback clocks are very well aligned. This effectively prevents false lock indications, and thus ensures a glitch free lock signal.

12.7.6.4 Power-down control

To reduce the power consumption when the PLL clock is not needed, a Power-down mode has been incorporated. In this mode, the internal current reference will be turned off, the oscillator and the phase-frequency detector will be stopped and the dividers will enter a reset state. While in Power-down mode, the lock output will be low to indicate that

the PLL is not in lock. When the Power-down mode is terminated, the PLL will resume its normal operation and will make the lock signal high once it has regained lock on the input clock.

12.7.6.5 Selectable feedback divider clock

To allow a trade-off to be made between functionality and power consumption, the feedback divider can be connected to either the CCO clock by setting FBSEL to 0 or to the output clock by setting FBSEL to 1. If the post-divider is used to divide down the CCO clock the current consumption of the feedback divider can be reduced by making it run on the lower output clock instead of the CCO clock, but doing so will limit the relation between output and phase detector clock frequencies to integer values.

12.7.6.6 Direct output mode

In normal operating mode (with DIRECT set to 0) the CCO clock is divided by 2, 4, 8 or 16 depending on the value of PSEL[1:0], automatically giving an output clock with a 50% duty cycle. If a higher output frequency is needed, the CCO clock can be sent directly to the output by setting DIRECT to 1. Since the CCO was designed to directly generate a clock with a 50% duty cycle, the output clock duty cycle will also be 50% in direct mode.

12.7.6.7 Divider ratio programming

Pre-divider

The pre-divider's division ratio is controlled by the NSEL[1:0] input. The division ratio between PLL's input clock and the phase detector clock is the decimal value on NSEL[1:0] plus one.

Post-divider

The division ratio of the post divider is controlled by the PSEL bits. The division ratio is two times the value of P selected by PSEL bits. This guarantees an output clock with a 50% duty cycle.

Feedback divider

The feedback divider's division ratio is controlled by the MSEL bits. The division ratio between the PLL's output clock and the input clock is the decimal value on MSEL bits plus one.

12.7.6.8 Frequency selection

The PLL frequency equations use the following parameters (also see [Figure 36](#)):

Integer mode

In this mode the post divider is enabled and the feedback divider is set to run on the PLL output clock, giving the following frequency relations:

(1)

$$FCLKOUT = M \times \frac{FCLKIN}{N}$$

(2)

$$FCCO = 2 \times P \times FCLKOUT = 2 \times P \times M \times \frac{FCLKIN}{N}$$

Non-integer mode

In this mode the post-divider is enabled and the feedback divider is set to run directly on the CCO clock, which gives the following frequency dividers:

(3)

$$FCLKOUT = \frac{FCCO}{2 \times P} = \frac{M}{2 \times P} \times \frac{FCLKIN}{N}$$

(4)

$$FCCO = M \times \frac{FCLKIN}{N}$$

Direct mode

In this mode, the post-divider is disabled and the CCO clock is sent directly to the output, leading to the following frequency equation:

(5)

$$FCLKOUT = FCCO = M \times \frac{FCLKIN}{N}$$

Power-down mode

In this mode, the internal current reference will be turned off, the oscillator and the phase-frequency detector will be stopped and the dividers will enter a reset state. While in Power-down mode, the lock output will be low, to indicate that the PLL is not in lock. When the Power-down mode is terminated, the PLL will resume its normal operation and will make the lock signal high once it has regained lock on the input clock.

12.8 Example CGU configurations

12.8.1 Programming the CGU for Deep-sleep and Power-down modes

Before the LPC18xx enters Deep-sleep or Power-down mode, the IRC must be programmed as the clock source in the control registers for all output stages (OUTCLK_0 to OUTCLK_27). In addition, the PLLs must be in Power-down mode.

When the LPC18xx wakes up from Deep-sleep or Power-down mode, the IRC is used as the clock sources for all output stages. Also see [Chapter 11](#).

12.8.2 Programming the CGU for using I2S at peripheral clock rate of 30 MHz

In this example the peripheral clock of the I2S interface is set to 30 MHz. The peripheral I2S clock is a branch of the BASE_APB1_CLK. Using a crystal of 12 MHz as clock source, a PLL1 multiplier of 10, and an integer divider of 4 provide the desired clock rate.

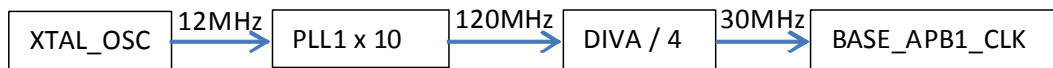

For this example, program the CGU as follows:

1. Enable the crystal oscillator in the XTAL_OSC_CTRL register ([Table 112](#)).
2. Wait for the crystal to stabilize.
3. Select the crystal oscillator as input to the PLL1 and set up the divider in the PLL1_CTRL register (see [Table 123](#)):
 - Set bits CLK_SEL in the PLL1_CTRL register to 0x6.
 - Set MSEL = 9.
 - Set NSEL = 0.
 - Set PSEL = 1.
 - Set FBSEL = 1.
 - Set BYPASS = 0, DIRECT = 0.
4. Wait for the PLL1 to lock.
5. Select the PLL1 as clock source of the integer divider A (IDIVA) in the IDIVA register and set AUTOBLOCK = 1 (see [Table 123](#)).
6. Select IDIVA as clock source of the base clock BASE_APB1_CLK and set AUTOBLOCK = 1 (see [Table 124](#)).
7. Ensure that the I2S branch clock CLK_APB1_I2S is enabled in the CCU (see [Table 142](#)).

12.8.3 PLL0USB settings for USB0 applications

[Table 136](#) shows examples of the M-divider and NP-divider register settings that produce a 480 MHz output clock for the USB0.

Table 136. PLL0 (for USB) settings for 480 MHz output clock

Fclkin [MHz]	PLL0USB_MDIV Table 115	PLL0USB_NP_DIV Table 116
1	0x073E 56C9	0x0030 2062
2	0x073E 2DAD	0x0030 2062
3	0x0B3E 34B1	0x0030 2062
4	0x0E3E 7777	0x0030 2062
5	0x0D32 6667	0x0030 2062
6	0x0B2A 2A66	0x0030 2062
8	0x0820 6AAA	0x0030 2062
10	0x071A 7FAA	0x0030 2062
12	0x0616 7FFA	0x0030 2062
15	0x0512 3FFF	0x0030 2062
16	0x0410 1FFF	0x0030 2062
20	0x040E 03FF	0x0030 2062
24	0x030C 00FF	0x0030 2062

12.8.4 PLL0AUDIO settings for audio applications

12.8.4.1 Using the fractional divider

[Table 137](#) shows typical divider settings for the audio PLL0 with the fractional divider active.

To use the fractional divider, follow these steps:

1. Set bit SEL_EXT = 0 and PLLFRACT_REQ = 1 in the PLL0AUDIO_CTRL register ([Table 118](#)).
2. Calculate NDEC, PDEC, and PLLFRACT_CTRL for the output frequency Fout.
3. Write the calculated NDEC and PDEC values to the PLL0AUDIO_NP_DIV register.
4. Write the calculated PLLFRACT_CTRL value to the PLL0AUDIOFRAC register.

Table 137. PLL0AUDIO divider settings for 12 MHz input

Fs [kHz]	Fout [MHz]	Fcco [MHz]	Error [Hz]	NDEC	PDEC	PLL0AUDIO_NP_DIV Table 120	PLLFRACT_CTRL Table 121
128Fs							
192	24.576	540.672	1	514	29	0x0000201d	0x16872b
96	12.288	417.792	1	1	3	0x00001003	0x1a1cac
88.2	11.2896	338.688	1	0	24	0x00000018	0x070e56
64	8.192	344.064	1	0	30	0x0000001e	0x072b02
48	6.144	307.2	1	1	6	0x00001006	0x133333
44.1	5.6448	282.24	1	1	6	0x00001006	0x11a3d7
256Fs							
192	49.152	491.52	11	514	5	0x00002005	0x147ae1
96	24.576	540.672	1	514	29	0x0000201d	0x16872b

Table 137. PLL0AUDIO divider settings for 12 MHz input

Fs [kHz]	Fout [MHz]	Fcco [MHz]	Error [Hz]	NDEC	PDEC	PLL0AUDIO_NP_DIV Table 120	PLLFORACT_CTRL Table 121
88.2	22.5792	451.584	1	1	14	0x0000100e	0x1c3958
64	16.384	360.448	1	1	29	0x0000101d	0x16872b
48	12.288	417.792	1	1	3	0x00001003	0x1a1cac
44.1	11.2896	338.688	1	0	24	0x00000018	0x070e56
32	8.192	344.064	1	0	30	0x0000001e	0x072b02
24	6.144	307.2	1	1	6	0x00001006	0x133333
22.05	5.6448	282.24	1	1	6	0x00001006	0x11a3d7
384Fs							
192	73.728	442.368	4	2		0x00002001	0x24dd2f
96	36.864	442.368	2	2		0x0000200a	0x24dd2f
88.2	33.8688	338.688	2	0		0x00000005	0x070e56
64	24.576	540.672	1	514		0x0000201d	0x16872b
48	18.432	442.368	1	2		0x0000201b	0x24dd2f
44.1	16.9344	338.688	1	0		0x0000000e	0x070e56
32	12.288	417.792	1	1		0x00001003	0x1a1cac
24	9.216	276.48	1	1		0x00001018	0x1147ae
22.05	8.4672	338.688	1	0		0x0000001f	0x070e56
16	6.144	307.2	1	1		0x00001006	0x133333
12	4.608	276.48	1	1		0x00001012	0x1147ae
512Fs							
192	98.304	393.216	30	2	66	0x00002042	0x20c49b
96	49.152	491.52	11	514	5	0x00002005	0x147ae1
88.2	45.1584	451.584	2	1	5	0x00001005	0x1c3958
64	32.768	458.752	4	1	21	0x00001015	0x1cac08
48	24.576	540.672	1	514	29	0x0000201d	0x16872b
44.1	22.5792	451.584	1	1	14	0x0000100e	0x1c3958
32	16.384	360.448	1	1	29	0x0000101d	0x16872b
24	12.288	417.792	1	1	3	0x00001003	0x1a1cac
22.05	11.2896	338.688	1	0	24	0x00000018	0x070e56
16	8.192	344.064	1	0	30	0x0000001e	0x072b02
12	6.144	307.2	1	1	6	0x00001006	0x133333
11.025	5.6448	282.24	1	1	6	0x00001006	0x11a3d7
1024Fs							
192	196.608	393.216	60	2	98	0x00002062	0x20c49b
96	98.304	393.216	30	2	66	0x00002042	0x20c49b
88.2	90.3168	541.9008	28	0	1	0x00000001	0x0b4a23
64	65.536	524.288	13	2	2	0x00002002	0x2bb0cf
48	49.152	491.52	11	514	5	0x00002005	0x147ae1
44.1	45.1584	451.584	2	1	5	0x00001005	0x1c3958
32	32.768	458.752	4	1	21	0x00001015	0x1cac08

Table 137. PLL0AUDIO divider settings for 12 MHz input

Fs [kHz]	Fout [MHz]	Fcco [MHz]	Error [Hz]	NDEC	PDEC	PLL0AUDIO_NP_DIV Table 120	PLL0FORACT_CTRL Table 121
24	24.576	540.672	1	514	29	0x0000201d	0x16872b
22.05	22.5792	451.584	1	1	14	0x0000100e	0x1c3958
16	16.384	360.448	1	1	29	0x0000101d	0x16872b
12	12.288	417.792	1	1	3	0x00001003	0x1a1cac
11.025	11.2896	338.688	1	0	24	0x00000018	0x070e56
8	8.192	344.064	1	0	30	0x0000001e	0x072b02

12.8.4.2 Bypassing the fractional divider

To bypass the fractional divider and use the MDEC value directly, follow these steps:

1. Set bit SEL_EXT = 1 in the PLL0AUDIO_CTRL register ([Table 118](#)).
2. Calculate NDEC, PDEC, and MDEC for the output frequency Fout.
3. Write the calculated NDEC and PDEC values to the PLL0AUDIO_NP_DIV register.
4. Write the calculated MDEC value to the PLL0AUDIO_MDIV register.

Table 138. PLL0AUDIO divider setting for 12 MHz with fractional divider bypassed

Fs [KHz]	Fout [MHz]	Fcco [MHz]	Error [Hz]	NDEC	MDEC	PDEC	PLL0AUDIO_MDIV Table 119	PLL0AUDIO_NP_DIV Table 120
128 Fs								
192	24.576	491.52	0	63	13523	14	0x000034d3	0x0003f00e
96	12.288	368.64	0	63	2665	24	0x00000a69	0x0003f018
88.2	11.2896	338.688	0	45	18810	24	0x0000497a	0x0002d018
64	8.192	409.6	0	61	18724	6	0x00004924	0x0003d006
48	6.144	307.2	0	5	30580	6	0x00007774	0x00005006
44.1	5.6448	282.24	0	63	31356	6	0x00007a7c	0x0003f006
256 Fs								
192	49.152	491.52	0	63	13523	5	0x000034d3	0x0003f005
96	24.576	491.52	0	63	13523	14	0x000034d3	0x0003f00e
88.2	22.5792	451.584	0	45	29122	14	0x000071c2	0x0002d00e
64	16.384	491.52	0	63	13523	24	0x000034d3	0x0003f018
48	12.288	368.64	0	63	2665	24	0x00000a69	0x0003f018
44.1	11.2896	338.688	0	45	18810	24	0x0000497a	0x0002d018
32	8.192	409.6	0	61	18724	6	0x00004924	0x0003d006
24	6.144	307.2	0	5	30580	6	0x00007774	0x00005006
22.05	5.6448	282.24	0	63	31356	6	0x00007a7c	0x0003f006
384 Fs								
192	73.728	294.912	0	45	4770	66	0x000012a2	0x0002d042
96	36.864	368.64	0	63	2665	5	0x00000a69	0x0003f005

Table 138. PLL0AUDIO divider setting for 12 MHz with fractional divider bypassed

Fs [kHz]	Fout [MHz]	Fcco [MHz]	Error [Hz]	NDEC	MDEC	PDEC	PLL0AUDIO_MDIV	PLL0AUDIO_NP_DIV
							Table 119	Table 120
88.2	33.8688	338.688	0	45	18810	5	0x0000497a	0x0002d005
64	24.576	491.52	0	63	13523	14	0x000034d3	0x0003f00e
48	18.432	368.64	0	63	2665	14	0x00000a69	0x0003f00e
44.1	16.9344	338.688	0	45	18810	14	0x0000497a	0x0002d00e
32	12.288	368.64	0	63	2665	24	0x00000a69	0x0003f018
24	9.216	460.8	0	5	12733	6	0x000031bd	0x00005006
22.05	8.4672	423.36	0	63	17692	6	0x0000451c	0x0003f006
16	6.144	307.2	0	5	30580	6	0x00007774	0x00005006
12	4.608	276.48	0	63	1513	18	0x000005e9	0x0003f012
512 Fs								
192	98.304	393.216	0	45	10784	66	0x00002a20	0x0002d042
96	49.152	491.52	0	63	13523	5	0x000034d3	0x0003f005
88.2	45.1584	451.584	0	45	29122	5	0x000071c2	0x0002d005
64	32.768	327.68	0	102	7482	5	0x00001d3a	0x00066005
48	24.576	491.52	0	63	13523	14	0x000034d3	0x0003f00e
44.1	22.5792	451.584	0	45	29122	14	0x000071c2	0x0002d00e
32	16.384	491.52	0	63	13523	24	0x000034d3	0x0003f018
24	12.288	368.64	0	63	2665	24	0x00000a69	0x0003f018
22.05	11.2896	338.688	0	45	18810	24	0x0000497a	0x0002d018
16	8.192	409.6	0	61	18724	6	0x00004924	0x0003d006
12	6.144	307.2	0	5	30580	6	0x00007774	0x00005006
11.025	5.6448	282.24	0	63	31356	6	0x00007a7c	0x0003f006
1024 Fs								
192	196.608	393.216	0	45	10784	98	0x00002a20	0x0002d062
96	98.304	393.216	0	45	10784	66	0x00002a20	0x0002d042
88.2	90.3168	541.901	31	181	3535	1	0x00000dcf	0x000b5001
64	65.536	393.216	0	45	10784	1	0x00002a20	0x0002d001
48	49.152	491.52	0	63	13523	5	0x000034d3	0x0003f005
44.1	45.1584	451.584	0	45	29122	5	0x000071c2	0x0002d005
32	32.768	327.68	0	102	7482	5	0x00001d3a	0x00066005
24	24.576	491.52	0	63	13523	14	0x000034d3	0x0003f00e
22.05	22.5792	451.584	0	45	29122	14	0x000071c2	0x0002d00e
16	16.384	491.52	0	63	13523	24	0x000034d3	0x0003f018
12	12.288	368.64	0	63	2665	24	0x00000a69	0x0003f018
11.025	11.2896	338.688	0	45	18810	24	0x0000497a	0x0002d018
8	8.192	409.6	0	61	18724	6	0x00004924	0x0003d006

13.1 How to read this chapter

Flash/EEPROM, Ethernet, USB0, USB1, and LCD related clocks are not available on all packages. See [Table 2](#) and [Table 4](#).

13.2 Basic configuration

The CCU1/2 are configured as follows:

- See [Table 139](#) for clocking and power control.
- All branch clocks are enabled by default.
- Do not reset the CCUs during normal operation.
- Configure the output clock for the EMC clock divider ([Table 148](#)) together with bit 16 in the CREG6 register ([Table 96](#)).

Table 139. CCU clocking and power control

	Base clock	Branch clock	Operating frequency
CCU1	BASE_M3_CLK	CLK_M3_BUS	up to 180 MHz
CCU2	BASE_M3_CLK	CLK_M3_BUS	up to 180 MHz

Remark: The CCU registers for a given branch clock are only read and write accessible when the branch clock is enabled.

13.3 Features

The CCUs switch the clocks to individual peripherals on or off.

- Auto mode activates the AHB disable protocol before switching off the branch clock.
- In Wake-up mode, clocks can be selected to run automatically after a wake-up event.

13.4 General description

Each CGU base clock has several clock branches which can be turned on or off independently by the Clock Control Units CCU1 or CCU2. The branch clocks are distributed between CCU1 and CCU2.

Table 140. CCU1 branch clocks

Base clock	Branch clock	Description
BASE_APB3_CLK	CLK_APB3_BUS	APB3 bus clock.
	CLK_APB3_I2C1	Clock to the I2C1 register interface and I2C1 peripheral clock.
	CLK_APB3_DAC	Clock to the DAC register interface.
	CLK_APB3_ADC0	Clock to the ADC0 register interface and ADC0 peripheral clock.
	CLK_APB3_ADC1	Clock to the ADC1 register interface and ADC1 peripheral clock.
	CLK_APB3_CAN0	Clock to the C_CAN0 register interface and C_CAN0 peripheral clock.
BASE_APB1_CLK	CLK_APB1_BUS	APB1 bus clock.
	CLK_APB1_MOTOCAN	Clock to the PWM Motor control block and PWM Motocon peripheral clock.
	CLK_APB1_I2C0	Clock to the I2C0 register interface and I2C0 peripheral clock.
	CLK_APB1_I2S	Clock to the I2S0 and I2S1 register interfaces and I2S0 and I2S1 peripheral clock.
	CLK_APB1_CAN1	Clock to the C_CAN1 register interface and C_CAN1 peripheral clock.
BASE_SPIFI_CLK	CLK_SPIFI	Clock to the SPIFI SCKI clock input.
BASE_M3_CLK	CLK_M3_BUS	M3 bus clock.
	CLK_M3_SPIFI	Clock to the SPIFI register interface.
	CLK_M3_GPIO	Clock to the GPIO register interface
	CLK_M3_LCD	Clock to the LCD register interface.
	CLK_M3_ETHERNET	Clock to the Ethernet register interface.
	CLK_M3_USB0	Clock to the USB0 register interface.
	CLK_M3 EMC	Clock to the External memory controller.
	CLK_M3_SDIO	Clock to the SD/MMC register interface.
	CLK_M3_DMA	Clock to the DMA register interface.
	CLK_M3_M3CORE	Clock to the Cortex-M3 core
	CLK_M3_SCT	Clock to the SCT register interface.
	CLK_M3_USB1	Clock to the USB1 register interface.
	CLK_M3 EMC_DIV	Clock to the EMC with clock divider.
	CLK_M3_FLASHA	Clock to the flash bank A
	CLK_M3_FLASHB	Clock to the flash bank B
	CLK_M3_EEPROM	Clock to the EEPROM
	CLK_M3_WWDT	Clock to the WWDT register interface.
	CLK_M3_UART0	Clock to the USART0 register interface.
	CLK_M3_UART1	Clock to the UART1 register interface.
	CLK_M3_SSP0	Clock to the SSP0 register interface.
CLK_M3_TIMER0	Clock to the timer0 register interface and timer0 peripheral clock.	

Table 140. CCU1 branch clocks

Base clock	Branch clock	Description
BASE_M3_CLK	CLK_M3_TIMER1	Clock to the timer1 register interface and timer1 peripheral clock.
	CLK_M3_SCU	Clock to the System control unit register interface.
	CLK_M3_CREG	Clock to the CREG register interface.
	CLK_M3_RITIMER	Clock to the RI timer register interface and RI timer peripheral clock.
	CLK_M3_UART2	Clock to the UART2 register interface.
	CLK_M3_UART3	Clock to the UART3 register interface.
	CLK_M3_TIMER2	Clock to the timer2 register interface and timer2 peripheral clock.
	CLK_M3_TIMER3	Clock to the timer3 register interface and timer3 peripheral clock.
	CLK_M3_SSP1	Clock to the SSP1 register interface.
	CLK_M3_QEI	Clock to the QEI register interface and QEI peripheral clock.
BASE_USB0_CLK	CLK_USB0	USB0 peripheral clock.
BASE_USB1_CLK	CLK_USB1	USB1 peripheral clock.
-	-	Reserved.

Table 141. CCU2 branch clocks

Base clock	Branch clock	Description
BASE_AUDIO_CLK	CLK_AUDIO	Audio system (I2S) clock.
BASE_UART3_CLK	CLK_APB2_UART3	USART3 peripheral clock.
BASE_UART2_CLK	CLK_APB2_UART2	USART2 peripheral clock.
BASE_UART1_CLK	CLK_APB0_UART1	UART1 peripheral clock.
BASE_UART0_CLK	CLK_APB0_UART0	USART0 peripheral clock.
BASE_SSP1_CLK	CLK_APB2_SSP1	SSP1 peripheral clock.
BASE_SSP0_CLK	CLK_APB0_SSP0	SSP0 peripheral clock.
BASE_SDIO_CLK	CLK_SDIO	SD/MMC peripheral clock.

13.5 Register description

Table 142. Register overview: CCU1 (base address 0x4005 1000)

Name	Access	Address offset	Description	Reset value	Reference
PM	R/W	0x000	CCU1 power mode register	0x0000 0000	Table 144
BASE_STAT	R	0x004	CCU1 base clocks status register	0x0000 0FFF	Table 145
-	-	0x008 to 0x0FC	Reserved	-	-
CLK_APB3_BUS_CFG	R/W	0x100	CLK_APB3_BUS clock configuration register	0x0000 0001	Table 147
CLK_APB3_BUS_STAT	R	0x104	CLK_APB3_BUS clock status register	0x0000 0001	Table 150
CLK_APB3_I2C1_CFG	R/W	0x108	CLK_APB3_I2C1 configuration register	0x0000 0001	Table 147
CLK_APB3_I2C1_STAT	R	0x10C	CLK_APB3_I2C1 status register	0x0000 0001	Table 150
CLK_APB3_DAC_CFG	R/W	0x110	CLK_APB3_DAC configuration register	0x0000 0001	Table 147
CLK_APB3_DAC_STAT	R	0x114	CLK_APB3_DAC status register	0x0000 0001	Table 150
CLK_APB3_ADC0_CFG	R/W	0x118	CLK_APB3_ADC0 configuration register	0x0000 0001	Table 147
CLK_APB3_ADC0_STAT	R	0x11C	CLK_APB3_ADC0 status register	0x0000 0001	Table 150
CLK_APB3_ADC1_CFG	R/W	0x120	CLK_APB3_ADC1 configuration register	0x0000 0001	Table 147
CLK_APB3_ADC1_STAT	R	0x124	CLK_APB3_ADC1 status register	0x0000 0001	Table 150
CLK_APB3_CAN0_CFG	R/W	0x128	CLK_APB3_CAN0 configuration register	0x0000 0001	Table 147
CLK_APB3_CAN0_STAT	R	0x12C	CLK_APB3_CAN0 status register	0x0000 0001	Table 150
-	-	0x130 to 0x1FC	Reserved	-	-
CLK_APB1_BUS_CFG	R/W	0x200	CLK_APB1_BUS configuration register	0x0000 0001	Table 147
CLK_APB1_BUS_STAT	R	0x204	CLK_APB1_BUS status register	0x0000 0001	Table 150
CLK_APB1_MOTOCON PWM_CFG	R/W	0x208	CLK_APB1_MOTOCON configuration register	0x0000 0001	Table 147
CLK_APB1_MOTOCON PWM_STAT	R	0x20C	CLK_APB1_MOTOCON status register	0x0000 0001	Table 150
CLK_APB1_I2C0_CFG	R/W	0x210	CLK_APB1_I2C0 configuration register	0x0000 0001	Table 147
CLK_APB1_I2C0_STAT	R	0x214	CLK_APB1_I2C0 status register	0x0000 0001	Table 150
CLK_APB1_I2S_CFG	R/W	0x218	CLK_APB1_I2S configuration register	0x0000 0001	Table 147
CLK_APB1_I2S_STAT	R	0x21C	CLK_APB1_I2S status register	0x0000 0001	Table 150
CLK_APB1_CAN1_CFG	R/W	0x220	CLK_APB3_CAN1 configuration register	0x0000 0001	Table 147
CLK_APB1_CAN1_STAT	R	0x224	CLK_APB3_CAN1 status register	0x0000 0001	Table 150
-	-	0x220 to 0x2FC	Reserved	-	-
CLK_SPIFI_CFG	R/W	0x300	CLK_SPIFI configuration register	0x0000 0001	Table 147
CLK_SPIFI_STAT	R	0x304	CLK_SPIFI status register	0x0000 0001	Table 150
-	-	0x308 to 0x3FC	Reserved	-	-
CLK_M3_BUS_CFG	R/W	0x400	CLK_M3_BUS configuration register	0x0000 0001	Table 147
CLK_M3_BUS_STAT	R	0x404	CLK_M3_BUS status register	0x0000 0001	Table 150
CLK_M3_SPIFI_CFG	R/W	0x408	CLK_M3_SPIFI configuration register	0x0000 0001	Table 147

Table 142. Register overview: CCU1 (base address 0x4005 1000)

Name	Access	Address offset	Description	Reset value	Reference
CLK_M3_SPIFI_STAT	R	0x40C	CLK_M3_SPIFI status register	0x0000 0001	Table 150
CLK_M3_GPIO_CFG	R/W	0x410	CLK_M3_GPIO configuration register	0x0000 0001	Table 147
CLK_M3_GPIO_STAT	R	0x414	CLK_M3_GPIO status register	0x0000 0001	Table 150
CLK_M3_LCD_CFG	R/W	0x418	CLK_M3_LCD configuration register	0x0000 0001	Table 147
CLK_M3_LCD_STAT	R	0x41C	CLK_M3_LCD status register	0x0000 0001	Table 150
CLK_M3_ETHERNET_CFG	R/W	0x420	CLK_M3_ETHERNET configuration register	0x0000 0001	Table 147
CLK_M3_ETHERNET_STAT	R	0x424	CLK_M3_ETHERNET status register	0x0000 0001	Table 150
CLK_M3_USB0_CFG	R/W	0x428	CLK_M3_USB0 configuration register	0x0000 0001	Table 147
CLK_M3_USB0_STAT	R	0x42C	CLK_M3_USB0 status register	0x0000 0001	Table 150
CLK_M3 EMC_CFG	R/W	0x430	CLK_M3 EMC configuration register	0x0000 0001	Table 147
CLK_M3 EMC_STAT	R	0x434	CLK_M3 EMC status register	0x0000 0001	Table 150
CLK_M3_SDIO_CFG	R/W	0x438	CLK_M3_SDIO configuration register	0x0000 0001	Table 147
CLK_M3_SDIO_STAT	R	0x43C	CLK_M3_SDIO status register	0x0000 0001	Table 150
CLK_M3_DMA_CFG	R/W	0x440	CLK_M3_DMA configuration register	0x0000 0001	Table 147
CLK_M3_DMA_STAT	R	0x444	CLK_M3_DMA status register	0x0000 0001	Table 150
CLK_M3_M3CORE_CFG	R/W	0x448	CLK_M3_M3CORE configuration register	0x0000 0001	Table 147
CLK_M3_M3CORE_STAT	R	0x44C	CLK_M3_M3CORE status register	0x0000 0001	Table 150
-	-	0x450 to 0x45C	Reserved	-	-
-	-	0x460 to 0x464	Reserved	-	-
CLK_M3_SCT_CFG	R/W	0x468	CLK_M3_SCT configuration register	0x0000 0001	Table 147
CLK_M3_SCT_STAT	R	0x46C	CLK_M3_SCT status register	0x0000 0001	Table 150
CLK_M3_USB1_CFG	R/W	0x470	CLK_M3_USB1 configuration register	0x0000 0001	Table 147
CLK_M3_USB1_STAT	R	0x474	CLK_M3_USB1 status register	0x0000 0001	Table 150
CLK_M3_EMCDIV_CFG	R/W	0x478	CLK_M3_EMCDIV configuration register	0x0000 0001	Table 148
CLK_M3_EMCDIV_STAT	R	0x47C	CLK_M3_EMCDIV status register	0x0000 0001	Table 150
CLK_M3_FLASHA_CFG	R/W	0x480	CLK_M3_FLASHA configuration register	0x0000 0001	Table 147
CLK_M3_FLASHA_STAT	R	0x484	CLK_M3_FLASHA status register	0x0000 0001	Table 150
CLK_M3_FLASHB_CFG	R/W	0x488	CLK_M3_FLASHB configuration register	0x0000 0001	Table 147
CLK_M3_FLASHB_STAT	R	0x48C	CLK_M3_FLASHB status register	0x0000 0001	Table 150
-	-	0x490	Reserved	-	-
-	-	0x494	Reserved	-	-
-	-	0x498	Reserved	-	-
-	-	0x49C	Reserved	-	-
CLK_M3_EEPROM_CFG		0x4A0	CLK_M3_EEPROM configuration register	0x0000 0001	Table 147
CLK_M3_EEPROM_STAT		0x4A4	CLK_M3_EEPROM status register	0x0000 0001	Table 150
-	-	0x4A8 to 0x4FC	Reserved	-	-
CLK_M3_WWDT_CFG	R/W	0x500	CLK_M3_WWDT configuration register	0x0000 0001	Table 147

Table 142. Register overview: CCU1 (base address 0x4005 1000)

Name	Access	Address offset	Description	Reset value	Reference
CLK_M3_WWDT_STAT	R	0x504	CLK_M3_WWDT status register	0x0000 0001	Table 150
CLK_M3_USART0_CFG	R/W	0x508	CLK_M3_UART0 configuration register	0x0000 0001	Table 147
CLK_M3_USART0_STAT	R	0x50C	CLK_M3_UART0 status register	0x0000 0001	Table 150
CLK_M3_UART1_CFG	R/W	0x510	CLK_M3_UART1 configuration register	0x0000 0001	Table 147
CLK_M3_UART1_STAT	R	0x514	CLK_M3_UART1 status register	0x0000 0001	Table 150
CLK_M3_SSP0_CFG	R/W	0x518	CLK_M3_SSP0 configuration register	0x0000 0001	Table 147
CLK_M3_SSP0_STAT	R	0x51C	CLK_M3_SSP0 status register	0x0000 0001	Table 150
CLK_M3_TIMER0_CFG	R/W	0x520	CLK_M3_TIMER0 configuration register	0x0000 0001	Table 147
CLK_M3_TIMER0_STAT	R	0x524	CLK_M3_TIMER0 status register	0x0000 0001	Table 150
CLK_M3_TIMER1_CFG	R/W	0x528	CLK_M3_TIMER1 configuration register	0x0000 0001	Table 147
CLK_M3_TIMER1_STAT	R	0x52C	CLK_M3_TIMER1 status register	0x0000 0001	Table 150
CLK_M3_SCU_CFG	R/W	0x530	CLK_M3_SCU configuration register	0x0000 0001	Table 147
CLK_M3_SCU_STAT	R	0x534	CLK_M3_SCU status register	0x0000 0001	Table 150
CLK_M3_CREG_CFG	R/W	0x538	CLK_M3_CREG configuration register	0x0000 0001	Table 147
CLK_M3_CREG_STAT	R	0x53C	CLK_M3_CREG status register	0x0000 0001	Table 150
-	-	0x540 to 0x5FC	Reserved	-	-
CLK_M3_RITIMER_CFG	R/W	0x600	CLK_M3_RITIMER configuration register	0x0000 0001	Table 147
CLK_M3_RITIMER_STAT	R	0x604	CLK_M3_RITIMER status register	0x0000 0001	Table 150
CLK_M3_USART2_CFG	R/W	0x608	CLK_M3_UART2 configuration register	0x0000 0001	Table 147
CLK_M3_USART2_STAT	R	0x60C	CLK_M3_UART2 status register	0x0000 0001	Table 150
CLK_M3_USART3_CFG	R/W	0x610	CLK_M3_UART3 configuration register	0x0000 0001	Table 147
CLK_M3_USART3_STAT	R	0x614	CLK_M3_UART3 status register	0x0000 0001	Table 150
CLK_M3_TIMER2_CFG	R/W	0x618	CLK_M3_TIMER2 configuration register	0x0000 0001	Table 147
CLK_M3_TIMER2_STAT	R	0x61C	CLK_M3_TIMER2 status register	0x0000 0001	Table 150
CLK_M3_TIMER3_CFG	R/W	0x620	CLK_M3_TIMER3 configuration register	0x0000 0001	Table 147
CLK_M3_TIMER3_STAT	R	0x624	CLK_M3_TIMER3 status register	0x0000 0001	Table 150
CLK_M3_SSP1_CFG	R/W	0x628	CLK_M3_SSP1 configuration register	0x0000 0001	Table 147
CLK_M3_SSP1_STAT	R	0x62C	CLK_M3_SSP1 status register	0x0000 0001	Table 150
CLK_M3_QEI_CFG	R/W	0x630	CLK_M3_QEI configuration register	0x0000 0001	Table 147
CLK_M3_QEI_STAT	R	0x634	CLK_M3_QEI status register	0x0000 0001	Table 150
-	R/W	0x638 to 0x6FC	Reserved	-	-
-	R/W	0x700 to 0x7FC	Reserved	-	-
CLK_USB0_CFG	R/W	0x800	CLK_USB0 configuration register	0x0000 0001	Table 147
CLK_USB0_STAT	R	0x804	CLK_USB0 status register	0x0000 0001	Table 150
-	-	0x808 to 0x8FC	Reserved	-	-
CLK_USB1_CFG	R/W	0x900	CLK_USB1 configuration register	0x0000 0001	Table 147
CLK_USB1_STAT	R	0x904	CLK_USB1 status register	0x0000 0001	Table 150

Table 142. Register overview: CCU1 (base address 0x4005 1000)

Name	Access	Address offset	Description	Reset value	Reference
-	-	0x908 to 0xAFC	Reserved	-	-
-	R/W	0xB00	Reserved	-	-
-	R	0xB04	Reserved	-	-

Table 143. Register overview: CCU2 (base address 0x4005 2000)

Name	Access	Address offset	Description	Reset value	Reference
PM	R/W	0x000	CCU2 power mode register	0x0000 0000	Table 144
BASE_STAT	R	0x004	CCU2 base clocks status register	0x0000 0FFF	Table 146
-	-	0x008 to 0x0FC	Reserved	-	-
CLK_AUDIO_CFG	R/W	0x100	CLK_AUDIO configuration register	0x0000 0001	Table 149
CLK_AUDIO_STAT	R	0x104	CLK_AUDIO status register	0x0000 0001	Table 151
-	-	0x108 to 0x1FC	Reserved	-	-
CLK_APB2_USART3_CFG	R/W	0x200	CLK_APB2_UART3 configuration register	0x0000 0001	Table 149
CLK_APB2_USART3_STAT	R	0x204	CLK_APB2_UART3 status register	0x0000 0001	Table 151
-	-	0x208 to 0x2FC	Reserved	-	-
CLK_APB2_USART2_CFG	R/W	0x300	CLK_APB2_UART2 configuration register	0x0000 0001	Table 149
CLK_APB2_USART2_STAT	R	0x304	CLK_APB2_UART2 status register	0x0000 0001	Table 151
-	-	0x308 to 0x3FC	Reserved	-	-
CLK_APB0_UART1_CFG	R/W	0x400	CLK_APB0_UART1 configuration register	0x0000 0001	Table 149
CLK_APB0_UART1_STAT	R	0x404	CLK_APB0_UART1 status register	0x0000 0001	Table 151
-	-	0x408 to 0x4FC	Reserved	-	-
CLK_APB0_USART0_CFG	R/W	0x500	CLK_APB0_UART0 configuration register	0x0000 0001	Table 149
CLK_APB0_USART0_STAT	R	0x504	CLK_APB0_UART0 status register	0x0000 0001	Table 151
-	-	0x508 to 0x5FC	Reserved	-	-
CLK_APB2_SSP1_CFG	R/W	0x600	CLK_APB2_SSP1 configuration register	0x0000 0001	Table 149
CLK_APB2_SSP1_STAT	R	0x604	CLK_APB2_SSP1 status register	0x0000 0001	Table 151
-	-	0x608 to 0x6FC	Reserved	-	-
CLK_APB0_SSP0_CFG	R/W	0x700	CLK_APB0_SSP0 configuration register	0x0000 0001	Table 149
CLK_APB0_SSP0_STAT	R	0x704	CLK_APB0_SSP0 status register	0x0000 0001	Table 151
-	-	0x708 to 0x7FC	Reserved	-	-
CLK_SDIO_CFG	R/W	0x800	CLK_SDIO configuration register (for SD/MMC)	0x0000 0001	Table 149
CLK_SDIO_STAT	R	0x804	CLK_SDIO status register (for SD/MMC)	0x0000 0001	Table 151

13.5.1 Power mode register

This register contains a single bit, PD, that disables all output clocks with Wake-up enabled ($W = 1$ in the CCU branch clock configuration registers, [Section 13.5.3](#)). Clocks disabled by writing to this register are reactivated when a wake-up interrupt is detected or when a 0 is written into the PD bit.

Table 144. CCU1/2 power mode register (CCU1_PM, address 0x4005 1000 and CCU2_PM, address 0x4005 2000) bit description

Bit	Symbol	Value	Description	Reset value	Access
0	PD		Initiate power-down mode	0	R/W
		0	Normal operation.		
		1	Clocks with wake-up mode enabled ($W = 1$) are disabled.		
31:1	-		Reserved.	-	-

13.5.2 Base clock status register

Each bit in this register indicates whether the specified base clock can be safely switched off. A logic zero indicates that all branch clocks generated from this base clock are disabled. Hence, the base clock can also be switched off. A logic one value indicates that there is still at least one branch clock running.

Remark: Reactivate this base clock before writing to the configuration register of the branch clock.

Table 145. CCU1 base clock status register (CCU1_BASE_STAT, address 0x4005 1004) bit description

Bit	Symbol	Description	Reset value	Access
0	BASE_APB3_CLK_IND	Base clock indicator for BASE_APB3_CLK 0 = All branch clocks switched off. 1 = At least one branch clock running.	1	R
1	BASE_APB1_CLK_IND	Base clock indicator for BASE_APB1_CLK 0 = All branch clocks switched off. 1 = At least one branch clock running.	1	R
2	BASE_SPIFI_CLK_IND	Base clock indicator for BASE_SPIFI_CLK 0 = All branch clocks switched off. 1 = At least one branch clock running.	1	R
3	BASE_M3_CLK_IND	Base clock indicator for BASE_M3_CLK 0 = All branch clocks switched off. 1 = At least one branch clock running.	1	R
6:4	-	Reserved	-	-

Table 145. CCU1 base clock status register (CCU1_BASE_STAT, address 0x4005 1004) bit description ...continued

Bit	Symbol	Description	Reset value	Access
7	BASE_USB0_CLK_IND	Base clock indicator for BASE_USB0_CLK 0 = All branch clocks switched off. 1 = At least one branch clock running.	1	R
8	BASE_USB1_CLK_IND	Base clock indicator for BASE_USB1_CLK 0 = All branch clocks switched off. 1 = at least one branch clock running.	1	R
31:9	-	Reserved	-	-

Table 146. CCU2 base clock status register (CCU2_BASE_STAT, address 0x4005 2004) bit description

Bit	Symbol	Description	Reset value	Access
0	-	Reserved.	-	-
1	BASE_UART3_CLK	Base clock indicator for BASE_UART3_CLK 0 = All branch clocks switched off. 1 = At least one branch clock running.	1	R
2	BASE_UART2_CLK	Base clock indicator for BASE_UART2_CLK 0 = All branch clocks switched off. 1 = At least one branch clock running.	1	R
3	BASE_UART1_CLK	Base clock indicator for BASE_UART1_CLK 0 = All branch clocks switched off. 1 = At least one branch clock running.	1	R
4	BASE_UART0_CLK	Base clock indicator for BASE_UART0_CLK 0 = All branch clocks switched off. 1 = At least one branch clock running.	1	R
5	BASE_SSP1_CLK	Base clock indicator for BASE_SSP1_CLK 0 = All branch clocks switched off. 1 = At least one branch clock running.	1	R
6	BASE_SSP0_CLK	Base clock indicator for BASE_SSP0_CLK 0 = All branch clocks switched off. 1 = At least one branch clock running.	1	R
7	-	Reserved.	-	-
31:8	-	Reserved.	-	-

13.5.3 CCU1/2 branch clock configuration registers

Each generated output clock from the CCU has a configuration register. They all follow the format as described in [Table 147](#) and [Table 149](#).

On the LPC18xx, all branch clocks are in Run mode after reset. Auto and wake-up features are disabled.

The clock can be configured to run in the following modes described by the bits RUN, AUTO, and WAKEUP in the CLK_XXX_CFG registers:

RUN — The WAKEUP, PD, and AUTO control bits determine the activation of the branch clock. If register bit AUTO is set, the AHB disable protocol must complete before the clock is switched off. The PD bit is shown in [Table 144](#).

AUTO — Enable auto (AHB disable mechanism). The PMC initiates the AHB disable protocol before switching the clock off. This protocol ensures that all AHB transactions have been completed before turning the clock off. However, if a bus master initiates a transfer and the bus is still active, ensure that all transfers have completed before turning off the master clock in auto mode. Otherwise, data may be lost when the master clock is turned off and the master can't process a response from the bus.

WAKEUP — The branch clock is wake-up enabled under the following conditions:

- The PD bit in the Power Mode register (see [Table 144](#)) is set.
- Wake-up enabled clocks are switched off.

Wake-up enabled clocks are switched on when a wake-up event is detected or when the PD bit is cleared. If register bit AUTO is set, the AHB disable protocol must complete before the clock is switched off.

Remark: To safely disable any of the branch clocks, use two separate writes to the CLK_XXX_CFG register: first set the AUTO bit, and then on the next write, disable the clock by setting the RUN bit to zero.

Table 147. CCU1 branch clock configuration register (CLK_XXX_CFG, addresses 0x4005 1100, 0x4005 1104,..., 0x4005 1A00) bit description

Bit	Symbol	Value	Description	Reset value	Access
0	RUN		Run enable	1	R/W
		0	Clock is disabled.		
		1	Clock is enabled.		
1	AUTO		Auto (AHB disable mechanism) enable	0	R/W
		0	Auto is disabled.		
		1	Auto is enabled.		
2	WAKEUP		Wake-up configure	0	R/W
		0	Wake-up is disabled.		
		1	Wake-up is enabled.		
31:3	-		Reserved	-	-

Remark: The output clock for the EMC clock divider ([Table 148](#)) must be configured together with bit 16 in the CREG6 register ([Table 96](#)).

Table 148. CCU1 branch clock configuration register (CLK_M3_EMCDIV_CFG, addresses 0x4005 1478) bit description

Bit	Symbol	Value	Description	Reset value	Access
0	RUN		Run enable	1	R/W
		0	Clock is disabled.		
		1	Clock is enabled.		

Table 148. CCU1 branch clock configuration register (CLK_M3_EMCDIV_CFG, addresses 0x4005 1478) bit description ...continued

Bit	Symbol	Value	Description	Reset value	Access
1	AUTO		Auto (AHB disable mechanism) enable	0	R/W
		0	Auto is disabled.		
		1	Auto is enabled.		
2	WAKEUP		Wake-up configure	0	R/W
		0	Wake-up is disabled.		
		1	Wake-up is enabled.		
3	-		Reserved	-	-
4	-		Reserved	-	-
7:5	DIV		Clock divider value. This bit field is for write access only. A read of this field returns an invalid value.	0	W
		0x0	No division (divide by 1).		
		0x1	Divide by 2.		
		0x2	Reserved		
		0x3	Reserved		
		0x4	Reserved		
26:8	-		Reserved	-	-
29:27	DIVSTAT		Clock divider status. When this bit field is read, the value of the DIV bit field in this register is returned.	0	R
31:30	-		Reserved	-	-

Table 149. CCU2 branch clock configuration register (CLK_XXX_CFG, addresses 0x4005 2100, 0x4005 2200,..., 0x4005 2800) bit description

Bit	Symbol	Value	Description	Reset value	Access
0	RUN		Run enable	1	R/W
		0	Clock is disabled.		
		1	Clock is enabled.		
1	AUTO		Auto (AHB disable mechanism) enable	0	R/W
		0	Auto is disabled.		
		1	Auto is enabled.		
2	WAKEUP		Wake-up configure	0	R/W
		0	Wake-up is disabled.		
		1	Wake-up is enabled.		
31:3	-		Reserved	-	-

13.5.4 CCU1/2 branch clock status registers

Each output clock generated from the CCU has a status register. When writing to the configuration register of an output clock, the Auto or Wake-up mechanism can delay the update of the actual hardware signals. The Status Register shows the current value of

these signals. All output clock Status Registers follow the format as described in [Table 150](#) and [Table 151](#).

Remark: The divider value for the CLK_M3_EMCDIV_CFG register is not reflected in the status register. Read the DIVSTAT bits in the CLK_M3_EMCDIV_CFG register for the divider status.

Table 150. CCU1 branch clock status register (CLK_XXX_STAT, addresses 0x4005 1104, 0x4005 110C, ..., 0x4005 1A04) bit description

Bit	Symbol	Description	Reset value	Access
0	RUN	Clock enable status 0 = clock is disabled. 1 = clock is enabled.	1	R
1	AUTO	Auto (AHB disable mechanism) enable status 0 = Auto is disabled. 1 = Auto is enabled.	0	R
2	WAKEUP	Wake-up mechanism enable status. This bit reads as 1 when the power down bit has been set in the PM register (PD = 1) and the clock has been configured to run after wake-up. 0 = Wake-up is disabled. 1 = Wake-up is enabled.	0	R
4:3	-	Reserved.	-	-
5	RUN_N	Clock disable status. This bit has same functionality as the RUN bit except with the opposite polarity. 0 = clock is enabled. 1 = clock is disabled.	0	R
31:6	-	Reserved	-	-

Table 151. CCU2 branch clock status register (CLK_XXX_STAT, addresses 0x4005 2104, 0x4005 2204, ..., 0x4005 2804) bit description

Bit	Symbol	Description	Reset value	Access
0	RUN	Clock enable status 0 = clock is disabled 1 = clock is enabled	1	R
1	AUTO	Auto (AHB disable mechanism) enable status 0 = Auto is disabled 1 = Auto is enabled	0	R
2	WAKEUP	Wake-up mechanism enable status. This bit reads as 1 when the power down bit has been set in the PM register (PD = 1) and the clock has been configured to run after wake-up. 0 = Wake-up is disabled 1 = Wake-up is enabled	0	R

Table 151. CCU2 branch clock status register (CLK_XXX_STAT, addresses 0x4005 2104, 0x4005 2204, ..., 0x4005 2804) bit description ...continued

Bit	Symbol	Description	Reset value	Access
4:3	-	Reserved.	-	-
5	RUN_N	Clock disable status. This bit has same functionality as the RUN bit except with the opposite polarity. 0 = clock is enabled. 1 = clock is disabled.	0	R
31:6	-	Reserved	-	-

14.1 How to read this chapter

Flash/EEPROM, Ethernet, USB0, USB1, and LCD and their related resets are not available on all packages or parts. See [Section 1.3](#). The corresponding reset control registers are reserved.

14.2 Basic configuration

Table 152. RGU clocking and power control

	Base clock	Branch clock	Operating frequency
RGU	BASE_M3_CLK	CLK_M3_BUS	up to 180 MHz
RGU delay clocks	BASE_SAFE_CLK	-	12 MHz

14.2.1 How to reset the LPC18xx by software

Software can reset the entire chip (with the exception of the battery powered domain) or various parts of the chip:

- To reset the entire chip (core, memories, and APB/AHB peripherals), set the CORE_RST bit in the RESET_CTRL0 register to 1. See [Table 156](#). Read the reset status in the RESET_ACTIVE_STATUS0 bit 0 ([Table 162](#)).
- To reset the M3 core and all AHB masters and AHB peripherals but not the APB peripherals, set the MASTER_RST bit in the RESET_CTRL0 register to 1. See [Table 156](#). Read the reset status in the RESET_ACTIVE_STATUS0 bit 2 ([Table 162](#)).
- Each core, memory block, and peripheral has a reset bit in the RESET_CTRL0 ([Table 156](#)) or RESET_CTRL1 ([Table 157](#)). To reset individual blocks, set the corresponding bit to 1.

14.3 General description

The RGU allows generation of independent reset signals for various blocks and peripherals on the LPC18xx. Each reset signal is asserted by a reset generator with one output (the reset signal) and one or more inputs, which link the reset generators together and create a reset hierarchy.

Remark: The ARM Cortex-M3 SYSRESETREQ triggers a peripheral reset PERIPH_RST.

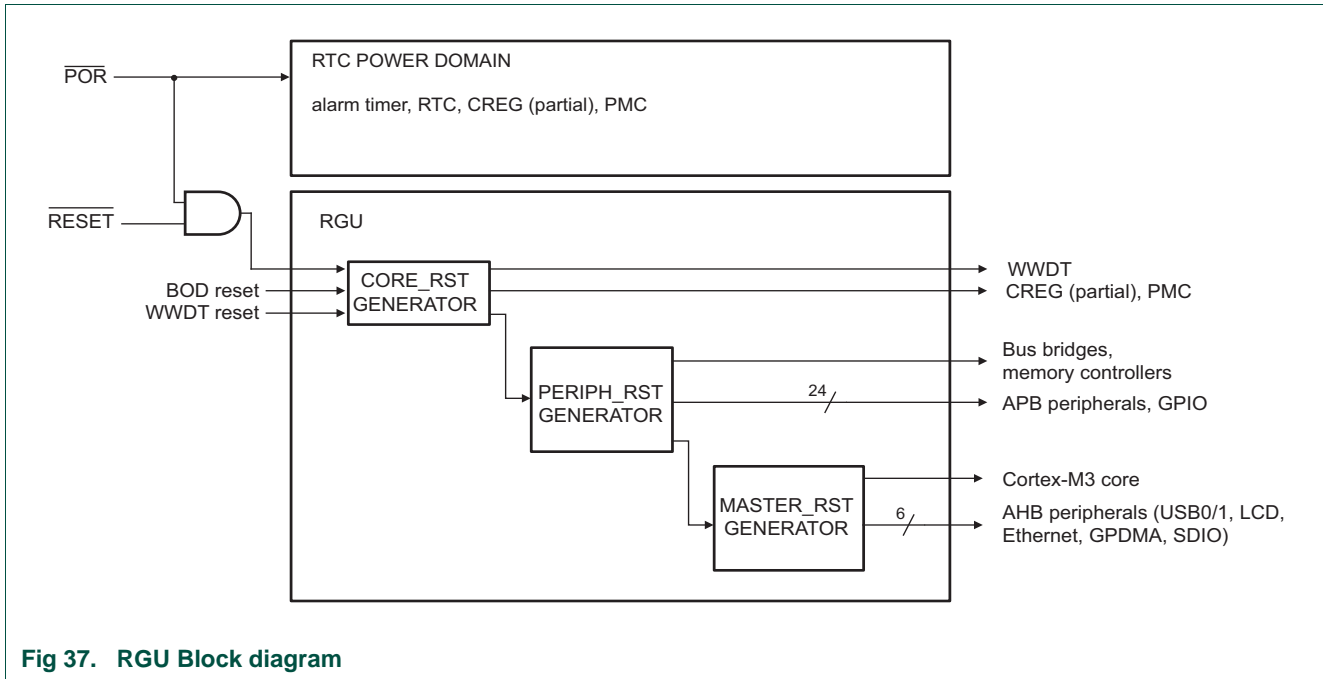

Fig 37. RGU Block diagram

Table 153. Reset output configuration

Reset generator	Reset output #	Reset source	Parts of the device reset when activated
CORE_RST	0	external reset pin $\overline{\text{RESET}}$, BOD reset, WWDT time-out reset, internal power failure, exiting from Deep power-down	Entire chip except: <ul style="list-style-type: none"> peripherals in the battery-powered domain. parts of creg.
PERIPH_RST	1	CORE_RST	All peripherals with reset source PERIPH_RST and MASTER_RST
MASTER_RST	2	PERIPH_RST	All peripherals with reset source MASTER_RST
Reserved	3	-	-
WWDT_RST	4	CORE_RST	WWDT. No software reset.
CREG_RST	5	CORE_RST	Configuration register block, No software reset.
Reserved	6 - 7	-	-
SCU_RST	9	PERIPH_RST	System control unit
Reserved	10 - 12	-	-
M3_RST	13	MASTER_RST	Cortex-M3 system reset
Reserved	14	-	-
Reserved	15	-	-
LCD_RST	16	MASTER_RST	LCD controller reset
USB0_RST	17	MASTER_RST	USB0 reset

Table 153. Reset output configuration ...continued

Reset generator	Reset output #	Reset source	Parts of the device reset when activated
USB1_RST	18	MASTER_RST	USB1 reset
DMA_RST	19	MASTER_RST	DMA reset
SDIO_RST	20	MASTER_RST	SDIO reset
EMC_RST	21	MASTER_RST	External memory controller reset
ETHERNET_RST	22	MASTER_RST	Ethernet reset
Reserved	23	-	-
Reserved	24	-	-
FLASHA_RST	25	PERIPH_RST	Flash bank A reset
Reserved	26	-	-
EEPROM_RST	27	PERIPH_RST	EEPROM reset
GPIO_RST	28	PERIPH_RST	GPIO reset
FLASHB_RST	29	PERIPH_RST	Flash bank B reset
Reserved	30	-	-
Reserved	31	-	-
TIMER0_RST	32	PERIPH_RST	Timer0 reset
TIMER1_RST	33	PERIPH_RST	Timer1 reset
TIMER2_RST	34	PERIPH_RST	Timer2 reset
TIMER3_RST	35	PERIPH_RST	Timer3 reset
RITIMER_RST	36	PERIPH_RST	Repetitive Interrupt timer reset
SCT_RST	37	PERIPH_RST	State Configurable Timer reset
MOTCONPWM_RST	38	PERIPH_RST	Motor control PWM reset
QEI_RST	39	PERIPH_RST	QEI reset
ADC0_RST	40	PERIPH_RST	ADC0 reset (ADC register interface and analog block)
ADC1_RST	41	PERIPH_RST	ADC1 reset (ADC register interface and analog block)
DAC_RST	42	PERIPH_RST	DAC reset (DAC register interface and analog block)
Reserved	43	-	-
UART0_RST	44	PERIPH_RST	USART0 reset
UART1_RST	45	PERIPH_RST	UART1 reset
UART2_RST	46	PERIPH_RST	USART2 reset
UART3_RST	47	PERIPH_RST	USART3 reset
I2C0_RST	48	PERIPH_RST	I2C0 reset
I2C1_RST	49	PERIPH_RST	I2C1 reset
SSP0_RST	50	PERIPH_RST	SSP0 reset
SSP1_RST	51	PERIPH_RST	SSP1 reset
I2S_RST	52	PERIPH_RST	I2S0 and I2S1 reset
SPIFI_RST	53	PERIPH_RST	SPIFI reset
CAN1_RST	54	PERIPH_RST	C_CAN1 reset

Table 153. Reset output configuration ...continued

Reset generator	Reset output #	Reset source	Parts of the device reset when activated
CAN0_RST	55	PERIPH_RST	C_CAN0 reset
Reserved	56	-	-
Reserved	57	-	-
Reserved	58 - 63	-	-

The RGU monitors the reset cause for each reset output using the RESET_STATUS0 to RESET_STATUS3 registers. The following reset causes are monitored in these registers:

- No reset has taken place.
- Reset generated by software (using the registers RESET_CTRL0 and RESET_CTRL1).
- Reset generated by any of the reset sources.

14.3.1 Reset hierarchy

The POR resets the entire chip with the exception of the backup registers in the RTC power domain. The reset hierarchy for the other reset sources is shown in [Table 154](#):

Table 154. Reset priority

Priority	Reset input	RTC peripherals ^[1] / Event router/ PMC	CREG	WWDT	RGU	ABP peripherals	GPIO	EMC	AHB masters: Cortex M3, USB, GPDMA, SDIO, Ethernet
0	POR	yes	yes	yes	yes	yes	yes	yes	yes
1	External reset pin, BOD and WWDT resets, internal power failure, exiting the Deep power-down mode	no	partial ^[2]	yes	yes	yes	yes	yes	yes
2	CORE_RST	no	partial ^[2]	yes	yes	yes	yes	yes	yes
3	PERIPH_RST	no	no	no	no	yes	yes	yes	yes
4	MASTER_RST	no	no	no	no	no	no	yes	yes

[1] Includes alarm timer and RTC. The POR does not reset the backup registers.

[2] The CREG0 register maintains its value during reset for partial resets.

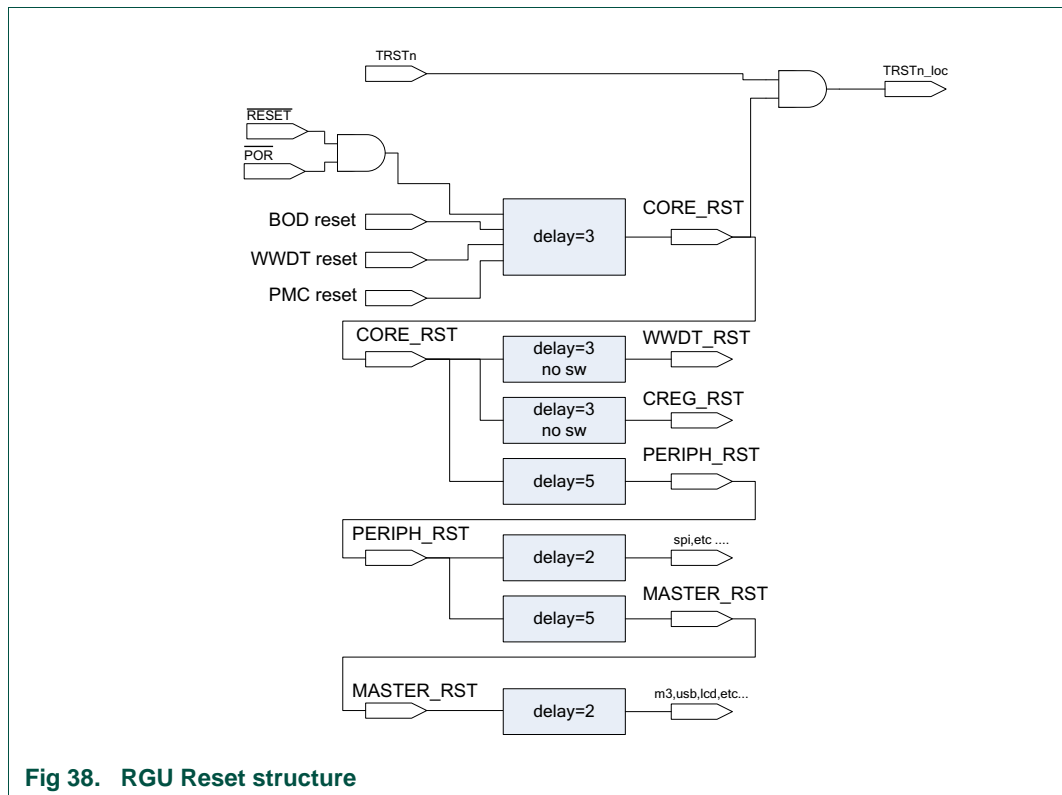

Fig 38. RGU Reset structure

14.4 Register overview

Table 155. Register overview: RGU (base address: 0x4005 3000)

Name	Access	Address offset	Description	Reset value	Reference
RESET_CTRL0	W	0x100	Reset control register 0	-	see Table 156
RESET_CTRL1	W	0x104	Reset control register 1	-	see Table 157
RESET_STATUS0	R/W	0x110	Reset status register 0	0x5555 0050	see Table 158
RESET_STATUS1	R/W	0x114	Reset status register 1	0x5555 5555	see Table 159
RESET_STATUS2	R/W	0x118	Reset status register 2	0x5555 5555	see Table 160
RESET_STATUS3	R/W	0x11C	Reset status register 3	0x5555 5555	see Table 161
RESET_ACTIVE_STATUS0	R	0x150	Reset active status register 0	0xFFFF EFFF	see Table 162
RESET_ACTIVE_STATUS1	R	0x154	Reset active status register 1	0xFEFF FFFF	see Table 163
-	-	0x400	Reserved	-	-
RESET_EXT_STAT1	R/W	0x404	Reset external status register 1 for PERIPH_RST	0x0	see Table 164
RESET_EXT_STAT2	R/W	0x408	Reset external status register 2 for MASTER_RST	0x4	see Table 165
-	-	0x40C	Reserved	-	-
-	-	0x410	Reserved	-	-

Table 155. Register overview: RGU (base address: 0x4005 3000) ...continued

Name	Access	Address offset	Description	Reset value	Reference
RESET_EXT_STAT5	R/W	0x414	Reset external status register 5 for CREG_RST	0x0	see Table 166
RESET_EXT_STAT6	-	0x418	Reserved	-	-
RESET_EXT_STAT7	-	0x41C	Reserved	-	-
RESET_EXT_STAT8	R/W	0x420	Reset external status register 8 for BUS_RST	0x4	see Table 167
RESET_EXT_STAT9	R/W	0x424	Reset external status register 9 for SCU_RST	0x4	see Table 167
RESET_EXT_STAT10	-	0x428	Reserved	-	-
RESET_EXT_STAT11	-	0x42C	Reserved	-	-
RESET_EXT_STAT12	-	0x430	Reserved	-	-
RESET_EXT_STAT13	R/W	0x434	Reset external status register 13 for M3_RST	0x8	see Table 168
RESET_EXT_STAT14	-	0x438	Reserved	-	-
RESET_EXT_STAT15	-	0x43C	Reserved	-	-
RESET_EXT_STAT16	R/W	0x440	Reset external status register 16 for LCD_RST	0x8	see Table 168
RESET_EXT_STAT17	R/W	0x444	Reset external status register 17 for USB0_RST	0x8	see Table 168
RESET_EXT_STAT18	R/W	0x448	Reset external status register 18 for USB1_RST	0x8	see Table 168
RESET_EXT_STAT19	R/W	0x44C	Reset external status register 19 for DMA_RST	0x8	see Table 168
RESET_EXT_STAT20	R/W	0x450	Reset external status register 20 for SDIO_RST	0x8	see Table 168
RESET_EXT_STAT21	R/W	0x454	Reset external status register 21 for EMC_RST	0x8	see Table 168
RESET_EXT_STAT22	R/W	0x458	Reset external status register 22 for ETHERNET_RST	0x8	see Table 168
RESET_EXT_STAT23	-	0x45C	Reserved	-	-
RESET_EXT_STAT24	-	0x460	Reserved	-	-
RESET_EXT_STAT25	R/W	0x464	Reset external status register 25 for FLASHA_RST	0x4	see Table 167
RESET_EXT_STAT26	-	0x468	Reserved	-	-
RESET_EXT_STAT27	R/W	0x46C	Reset external status register 27 for EEPROM_RST	0x4	see Table 167
RESET_EXT_STAT28	R/W	0x470	Reset external status register 28 for GPIO_RST	0x4	see Table 167
RESET_EXT_STAT29	R/W	0x474	Reset external status register 29 for FLASHB_RST	0x4	see Table 167
RESET_EXT_STAT30	-	0x478	Reserved	-	-
RESET_EXT_STAT31	-	0x47C	Reserved	-	-
RESET_EXT_STAT32	R/W	0x480	Reset external status register 32 for TIMER0_RST	0x4	see Table 167

Table 155. Register overview: RGU (base address: 0x4005 3000) ...continued

Name	Access	Address offset	Description	Reset value	Reference
RESET_EXT_STAT33	R/W	0x484	Reset external status register 33 for TIMER1_RST	0x4	see Table 167
RESET_EXT_STAT34	R/W	0x488	Reset external status register 34 for TIMER2_RST	0x4	see Table 167
RESET_EXT_STAT35	R/W	0x48C	Reset external status register 35 for TIMER3_RST	0x4	see Table 167
RESET_EXT_STAT36	R/W	0x490	Reset external status register 36 for RITIMER_RST	0x4	see Table 167
RESET_EXT_STAT37	R/W	0x494	Reset external status register 37 for SCT_RST	0x4	see Table 167
RESET_EXT_STAT38	R/W	0x498	Reset external status register 38 for MOTOCONPWM_RST	0x4	see Table 167
RESET_EXT_STAT39	R/W	0x49C	Reset external status register 39 for QEI_RST	0x4	see Table 167
RESET_EXT_STAT40	R/W	0x4A0	Reset external status register 40 for ADC0_RST	0x4	see Table 167
RESET_EXT_STAT41	R/W	0x4A4	Reset external status register 41 for ADC1_RST	0x4	see Table 167
RESET_EXT_STAT42	R/W	0x4A8	Reset external status register 42 for DAC_RST	0x4	see Table 167
RESET_EXT_STAT43	-	0x4AC	Reserved	-	-
RESET_EXT_STAT44	R/W	0x4B0	Reset external status register 44 for UART0_RST	0x4	see Table 167
RESET_EXT_STAT45	R/W	0x4B4	Reset external status register 45 for UART1_RST	0x4	see Table 167
RESET_EXT_STAT46	R/W	0x4B8	Reset external status register 46 for UART2_RST	0x4	see Table 167
RESET_EXT_STAT47	R/W	0x4BC	Reset external status register 47 for UART3_RST	0x4	see Table 167
RESET_EXT_STAT48	R/W	0x4C0	Reset external status register 48 for I2C0_RST	0x4	see Table 167
RESET_EXT_STAT49	R/W	0x4C4	Reset external status register 49 for I2C1_RST	0x4	see Table 167
RESET_EXT_STAT50	R/W	0x4C8	Reset external status register 50 for SSP0_RST	0x4	see Table 167
RESET_EXT_STAT51	R/W	0x4CC	Reset external status register 51 for SSP1_RST	0x4	see Table 167
RESET_EXT_STAT52	R/W	0x4D0	Reset external status register 52 for I2S_RST	0x4	see Table 167
RESET_EXT_STAT53	R/W	0x4D4	Reset external status register 53 for SPIFI_RST	0x4	see Table 167
RESET_EXT_STAT54	R/W	0x4D8	Reset external status register 54 for CAN1_RST	0x4	see Table 167
RESET_EXT_STAT55	R/W	0x4DC	Reset external status register 55 for CAN0_RST	0x4	see Table 167
RESET_EXT_STAT56	-	0x4E0	Reserved	-	-

Table 155. Register overview: RGU (base address: 0x4005 3000) ...continued

Name	Access	Address offset	Description	Reset value	Reference
RESET_EXT_STAT57	-	0x4E4	Reserved	-	-
RESET_EXT_STAT58	-	0x4E8	Reserved	-	-
RESET_EXT_STAT59	-	0x4EC	Reserved	-	-
RESET_EXT_STAT60	-	0x4F0	Reserved	-	-
RESET_EXT_STAT61	-	0x4F4	Reserved	-	-
RESET_EXT_STAT62	-	0x4F8	Reserved	-	-
RESET_EXT_STAT63	-	0x4FC	Reserved	-	-

14.4.1 RGU reset control register

The RGU reset control register allows software to activate and clear individual reset outputs. Each bit corresponds to an individual reset output, and writing a one activates that output. The reset output is automatically de-activated after a fixed delay period. If the reset output has a manual release, it stays activated once pulled low until a 0 is written to the appropriate bit in this register. This applies whether the reset activation came from the Reset Control Register or any other source.

Remark: The reset delay is counted in IRC clock cycles. If the core frequency CCLK is much higher than the IRC frequency, add a software delay of $f_{\text{CCLK}}/f_{\text{IRC}}$ clock cycles between resetting and accessing any of the peripheral blocks.

Table 156. Reset control register 0 (RESET_CTRL0, address 0x4005 3100) bit description

Bit	Symbol	Description	Reset value	Access
0	CORE_RST	Writing a one activates the reset. This bit is automatically cleared to 0 after one clock cycle.	0	W
1	PERIPH_RST	Writing a one activates the reset. This bit is automatically cleared to 0 after three clock cycles.	0	W
2	MASTER_RST	Writing a one activates the reset. This bit is automatically cleared to 0 after three clock cycles.	0	W
3	-	Reserved	0	-
4	WWDT_RST	Writing a one to this bit has no effect.	0	-
5	CREG_RST	Writing a one to this bit has no effect.	0	-
6	-	Reserved	0	-
7	-	Reserved	0	-
8	BUS_RST	Writing a one activates the reset. This bit is automatically cleared to 0 after one clock cycle. Do not use during normal operation	0	W
9	SCU_RST	Writing a one activates the reset. This bit is automatically cleared to 0 after one clock cycle.	0	W
10	-	Reserved	0	-
11	-	Reserved	0	-
12	-	Reserved	0	-
13	M3_RST	Writing a one activates the reset. This bit is automatically cleared to 0 after one clock cycle.	0	W
14	-	Reserved	0	-

Table 156. Reset control register 0 (RESET_CTRL0, address 0x4005 3100) bit description ...continued

Bit	Symbol	Description	Reset value	Access
15	-	Reserved	0	-
16	LCD_RST	Writing a one activates the reset. This bit is automatically cleared to 0 after one clock cycle.	0	W
17	USB0_RST	Writing a one activates the reset. This bit is automatically cleared to 0 after one clock cycle.	0	W
18	USB1_RST	Writing a one activates the reset. This bit is automatically cleared to 0 after one clock cycle.	0	W
19	DMA_RST	Writing a one activates the reset. This bit is automatically cleared to 0 after one clock cycle.	0	W
20	SDIO_RST	Writing a one activates the reset. This bit is automatically cleared to 0 after one clock cycle.	0	W
21	EMC_RST	Writing a one activates the reset. This bit is automatically cleared to 0 after one clock cycle.	0	W
22	ETHERNET_RST	Writing a one activates the reset. This bit is automatically cleared to 0 after one clock cycle.	0	W
23	-	Reserved	-	-
24	-	Reserved	-	-
25	FLASHA_RST	Writing a one activates the reset. This bit is automatically cleared to 0 after one clock cycle.	0	W
26	-	Reserved	-	-
27	EEPROM_RST	Writing a one activates the reset. This bit is automatically cleared to 0 after one clock cycle.	0	W
28	GPIO_RST	Writing a one activates the reset. This bit is automatically cleared to 0 after one clock cycle.	0	W
29	FLASHB_RST	Writing a one activates the reset. This bit is automatically cleared to 0 after one clock cycle.	0	W
30	-	Reserved	-	-
31	-	Reserved	-	-

Table 157. Reset control register 1 (RESET_CTRL1, address 0x4005 3104) bit description

Bit	Symbol	Description	Reset value	Access
0	TIMER0_RST	Writing a one activates the reset. This bit is automatically cleared to 0 after one clock cycle.	0	W
1	TIMER1_RST	Writing a one activates the reset. This bit is automatically cleared to 0 after one clock cycle.	0	W
2	TIMER2_RST	Writing a one activates the reset. This bit is automatically cleared to 0 after one clock cycle.	0	W
3	TIMER3_RST	Writing a one activates the reset. This bit is automatically cleared to 0 after one clock cycle.	0	W
4	RITIMER_RST	Writing a one activates the reset. This bit is automatically cleared to 0 after one clock cycle.	0	W
5	SCT_RST	Writing a one activates the reset. This bit is automatically cleared to 0 after one clock cycle.	0	W

Table 157. Reset control register 1 (RESET_CTRL1, address 0x4005 3104) bit description

...continued

Bit	Symbol	Description	Reset value	Access
6	MOTOCONPWM_RST	Writing a one activates the reset. This bit is automatically cleared to 0 after one clock cycle.	0	W
7	QEI_RST	Writing a one activates the reset. This bit is automatically cleared to 0 after one clock cycle.	0	W
8	ADC0_RST	Writing a one activates the reset. This bit is automatically cleared to 0 after one clock cycle.	0	W
9	ADC1_RST	Writing a one activates the reset. This bit is automatically cleared to 0 after one clock cycle.	0	W
10	DAC_RST	Writing a one activates the reset. This bit is automatically cleared to 0 after one clock cycle.	0	W
11	-	Reserved	-	-
12	UART0_RST	Writing a one activates the reset. This bit is automatically cleared to 0 after one clock cycle.	0	W
13	UART1_RST	Writing a one activates the reset. This bit is automatically cleared to 0 after one clock cycle.	0	W
14	UART2_RST	Writing a one activates the reset. This bit is automatically cleared to 0 after one clock cycle.	0	W
15	UART3_RST	Writing a one activates the reset. This bit is automatically cleared to 0 after one clock cycle.	0	W
16	I2C0_RST	Writing a one activates the reset. This bit is automatically cleared to 0 after one clock cycle.	0	W
17	I2C1_RST	Writing a one activates the reset. This bit is automatically cleared to 0 after one clock cycle.	0	W
18	SSP0_RST	Writing a one activates the reset. This bit is automatically cleared to 0 after one clock cycle.	0	W
19	SSP1_RST	Writing a one activates the reset. This bit is automatically cleared to 0 after one clock cycle.	0	W
20	I2S_RST	Writing a one activates the reset. This bit is automatically cleared to 0 after one clock cycle.	0	W
21	SPIFI_RST	Writing a one activates the reset. This bit is automatically cleared to 0 after one clock cycle.	0	W
22	CAN1_RST	Writing a one activates the reset. This bit is automatically cleared to 0 after one clock cycle.	0	W
23	CAN0_RST	Writing a one activates the reset. This bit is automatically cleared to 0 after one clock cycle.	0	W
24	-	Reserved	-	-
25	-	Reserved	-	-
26	-	Reserved	-	-
27	-	Reserved	-	-
28	-	Reserved	-	-
29	-	Reserved	-	-
30	-	Reserved	-	-
31	-	Reserved	-	-

14.4.2 RGU reset status register

The reset status register shows which source (if any) caused the last reset activation per individual reset output of the RGU. When one (or more) inputs of the RGU caused the Reset Output to go active (indicated by value 01), the corresponding RESET_EXT_STATUS register can be read, see [Section 14.4.4](#).

The RESET_STATUS registers are cleared by writing 0 to each of the status bits.

Table 158. Reset status register 0 (RESET_STATUS0, address 0x4005 3110) bit description

Bit	Symbol	Description	Reset value	Access
1:0	-	Reserved	00	-
3:2	PERIPH_RST	Status of the PERIPH_RST reset generator output 00 = No reset activated 01 = Reset output activated by input to the reset generator 10 = Reserved 11 = Reset output activated by software write to RESET_CTRL register	00	R/W
5:4	MASTER_RST	Status of the MASTER_RST reset generator output 00 = No reset activated 01 = Reset output activated by input to the reset generator 10 = Reserved 11 = Reset output activated by software write to RESET_CTRL register	01	R/W
7:6	-	Reserved	01	
9:8	WWDT_RST	Status of the WWDT_RST reset generator output 00 = No reset activated 01 = Reset output activated by input to the reset generator 10 = Reserved 11 = Reserved	00	R/W
11:10	CREG_RST	Status of the CREG_RST reset generator output 00 = No reset activated 01 = Reset output activated by input to the reset generator 10 = Reserved 11 = Reserved	00	R/W
13:12	-	Reserved	01	-
15:14	-	Reserved	01	-
17:16	BUS_RST	Status of the BUS_RST reset generator output 00 = No reset activated 01 = Reset output activated by input to the reset generator 10 = Reserved 11 = Reset output activated by software write to RESET_CTRL register	01	R/W
19:18	SCU_RST	Status of the SCU_RST reset generator output 00 = No reset activated 01 = Reset output activated by input to the reset generator 10 = Reserved 11 = Reset output activated by software write to RESET_CTRL register	01	R/W
21:20	-	Reserved	01	-

Table 158. Reset status register 0 (RESET_STATUS0, address 0x4005 3110) bit description

Bit	Symbol	Description	Reset value	Access
23:22	-	Reserved	01	-
25:24	-	Reserved	01	-
27:26	M3_RST	Status of the M3_RST reset generator output 00 = No reset activated 01 = Reset output activated by input to the reset generator 10 = Reserved 11 = Reset output activated by software write to RESET_CTRL register	01	R/W
29:28	-	Reserved	01	-
31:30	-	Reserved	01	-

Table 159. Reset status register 1 (RESET_STATUS1, address 0x4005 3114) bit description

Bit	Symbol	Description	Reset value	Access
1:0	LCD_RST	Status of the LCD_RST reset generator output 00 = No reset activated 01 = Reset output activated by input to the reset generator 10 = Reserved 11 = Reset output activated by software write to RESET_CTRL register	01	R/W
3:2	USB0_RST	Status of the USB0_RST reset generator output 00 = No reset activated 01 = Reset output activated by input to the reset generator 10 = Reserved 11 = Reset output activated by software write to RESET_CTRL register	01	R/W
5:4	USB1_RST	Status of the USB1_RST reset generator output 00 = No reset activated 01 = Reset output activated by input to the reset generator 10 = Reserved 11 = Reset output activated by software write to RESET_CTRL register	01	R/W
7:6	DMA_RST	Status of the DMA_RST reset generator output 00 = No reset activated 01 = Reset output activated by input to the reset generator 10 = Reserved 11 = Reset output activated by software write to RESET_CTRL register	01	R/W
9:8	SDIO_RST	Status of the SDIO_RST reset generator output 00 = No reset activated 01 = Reset output activated by input to the reset generator 10 = Reserved 11 = Reset output activated by software write to RESET_CTRL register	01	R/W

Table 159. Reset status register 1 (RESET_STATUS1, address 0x4005 3114) bit description
...continued

Bit	Symbol	Description	Reset value	Access
11:10	EMC_RST	Status of the EMC_RST reset generator output 00 = No reset activated 01 = Reset output activated by input to the reset generator 10 = Reserved 11 = Reset output activated by software write to RESET_CTRL register	01	R/W
13:12	ETHERNET_RST	Status of the ETHERNET_RST reset generator output 00 = No reset activated 01 = Reset output activated by input to the reset generator 10 = Reserved 11 = Reset output activated by software write to RESET_CTRL register	01	R/W
15:14	-	Reserved	01	-
17:16	-	Reserved	01	-
19:18	FLASHA_RST	Status of the FLASHA_RST reset generator output 00 = No reset activated 01 = Reset output activated by input to the reset generator 10 = Reserved 11 = Reset output activated by software write to RESET_CTRL register	01	-
21:20	-	Reserved	01	-
23:22	EEPROM_RST	Status of the EEPROM_RST reset generator output 00 = No reset activated 01 = Reset output activated by input to the reset generator 10 = Reserved 11 = Reset output activated by software write to RESET_CTRL register	01	-
25:24	GPIO_RST	Status of the GPIO_RST reset generator output 00 = No reset activated 01 = Reset output activated by input to the reset generator 10 = Reserved 11 = Reset output activated by software write to RESET_CTRL register	01	R/W
27:26	FLASHB_RST	Status of the FLASHB_RST reset generator output 00 = No reset activated 01 = Reset output activated by input to the reset generator 10 = Reserved 11 = Reset output activated by software write to RESET_CTRL register	01	-
29:28	-	Reserved	01	-
31:30	-	Reserved	01	-

Table 160. Reset status register 2 (RESET_STATUS2, address 0x4005 3118) bit description

Bit	Symbol	Description	Reset value	Access
1:0	TIMER0_RST	Status of the TIMER0_RST reset generator output 00 = No reset activated 01 = Reset output activated by input to the reset generator 10 = Reserved 11 = Reset output activated by software write to RESET_CTRL register	01	R/W
3:2	TIMER1_RST	Status of the TIMER1_RST reset generator output 00 = No reset activated 01 = Reset output activated by input to the reset generator 10 = Reserved 11 = Reset output activated by software write to RESET_CTRL register	01	R/W
5:4	TIMER2_RST	Status of the TIMER2_RST reset generator output 00 = No reset activated 01 = Reset output activated by input to the reset generator 10 = Reserved 11 = Reset output activated by software write to RESET_CTRL register	01	R/W
7:6	TIMER3_RST	Status of the TIMER3_RST reset generator output 00 = No reset activated 01 = Reset output activated by input to the reset generator 10 = Reserved 11 = Reset output activated by software write to RESET_CTRL register	01	R/W
9:8	RITIMER_RST	Status of the RITIMER_RST reset generator output 00 = No reset activated 01 = Reset output activated by input to the reset generator 10 = Reserved 11 = Reset output activated by software write to RESET_CTRL register	01	R/W
11:10	SCT_RST	Status of the SCT_RST reset generator output 00 = No reset activated 01 = Reset output activated by input to the reset generator 10 = Reserved 11 = Reset output activated by software write to RESET_CTRL register	01	R/W
13:12	MOTOCONPWM_RST	Status of the MOTOCONPWM_RST reset generator output 00 = No reset activated 01 = Reset output activated by input to the reset generator 10 = Reserved 11 = Reset output activated by software write to RESET_CTRL register	01	R/W
15:14	QEI_RST	Status of the QEI_RST reset generator output 00 = No reset activated 01 = Reset output activated by input to the reset generator 10 = Reserved 11 = Reset output activated by software write to RESET_CTRL register	01	R/W

Table 160. Reset status register 2 (RESET_STATUS2, address 0x4005 3118) bit description ...continued
...continued

Bit	Symbol	Description	Reset value	Access
17:16	ADC0_RST	Status of the ADC0_RST reset generator output 00 = No reset activated 01 = Reset output activated by input to the reset generator 10 = Reserved 11 = Reset output activated by software write to RESET_CTRL register	01	R/W
19:18	ADC1_RST	Status of the ADC1_RST reset generator output 00 = No reset activated 01 = Reset output activated by input to the reset generator 10 = Reserved 11 = Reset output activated by software write to RESET_CTRL register	01	R/W
21:20	DAC_RST	Status of the DAC_RST reset generator output 00 = No reset activated 01 = Reset output activated by input to the reset generator 10 = Reserved 11 = Reset output activated by software write to RESET_CTRL register	01	R/W
23:22	-	Reserved	01	R/W
25:24	UART0_RST	Status of the UART0_RST reset generator output 00 = No reset activated 01 = Reset output activated by input to the reset generator 10 = Reserved 11 = Reset output activated by software write to RESET_CTRL register	01	R/W
27:26	UART1_RST	Status of the UART1_RST reset generator output 00 = No reset activated 01 = Reset output activated by input to the reset generator 10 = Reserved 11 = Reset output activated by software write to RESET_CTRL register	01	R/W
29:28	UART2_RST	Status of the UART2_RST reset generator output 00 = No reset activated 01 = Reset output activated by input to the reset generator 10 = Reserved 11 = Reset output activated by software write to RESET_CTRL register	01	R/W
31:30	UART3_RST	Status of the UART3_RST reset generator output 00 = No reset activated 01 = Reset output activated by input to the reset generator 10 = Reserved 11 = Reset output activated by software write to RESET_CTRL register	01	R/W

Table 161. Reset status register 3 (RESET_STATUS3, address 0x4005 311C) bit description

Bit	Symbol	Description	Reset value	Access
1:0	I2C0_RST	Status of the I2C0_RST reset generator output 00 = No reset activated 01 = Reset output activated by input to the reset generator 10 = Reserved 11 = Reset output activated by software write to RESET_CTRL register	01	R/W
3:2	I2C1_RST	Status of the I2C1_RST reset generator output 00 = No reset activated 01 = Reset output activated by input to the reset generator 10 = Reserved 11 = Reset output activated by software write to RESET_CTRL register	01	R/W
5:4	SSP0_RST	Status of the SSP0_RST reset generator output 00 = No reset activated 01 = Reset output activated by input to the reset generator 10 = Reserved 11 = Reset output activated by software write to RESET_CTRL register	01	R/W
7:6	SSP1_RST	Status of the SSP1_RST reset generator output 00 = No reset activated 01 = Reset output activated by input to the reset generator 10 = Reserved 11 = Reset output activated by software write to RESET_CTRL register	01	R/W
9:8	I2S_RST	Status of the I2S_RST reset generator output 00 = No reset activated 01 = Reset output activated by input to the reset generator 10 = Reserved 11 = Reset output activated by software write to RESET_CTRL register	01	R/W
11:10	SPIFI_RST	Status of the SPIFI_RST reset generator output 00 = No reset activated 01 = Reset output activated by input to the reset generator 10 = Reserved 11 = Reset output activated by software write to RESET_CTRL register	01	R/W
13:12	CAN1_RST	Status of the CAN1_RST reset generator output 00 = No reset activated 01 = Reset output activated by input to the reset generator 10 = Reserved 11 = Reset output activated by software write to RESET_CTRL register	01	R/W
15:14	CAN0_RST	Status of the CAN0_RST reset generator output 00 = No reset activated 01 = Reset output activated by input to the reset generator 10 = Reserved 11 = Reset output activated by software write to RESET_CTRL register	01	R/W
17:16	-	Reserved	01	-

Table 161. Reset status register 3 (RESET_STATUS3, address 0x4005 311C) bit description
...continued

Bit	Symbol	Description	Reset value	Access
19:18	-	Reserved	01	-
21:20	-	Reserved	01	-
23:22	-	Reserved	01	-
25:24	-	Reserved	01	-
27:26	-	Reserved	01	-
29:28	-	Reserved	01	-
31:30	-	Reserved	01	-

14.4.3 RGU reset active status register

The reset active status register shows the current value of the reset outputs of the RGU. Note that the resets are active LOW.

Table 162. Reset active status register 0 (RESET_ACTIVE_STATUS0, address 0x4005 3150) bit description

Bit	Symbol	Description	Reset value	Access
0	CORE_RST	Current status of the CORE_RST 0 = Reset asserted 1 = No reset	1	R
1	PERIPH_RST	Current status of the PERIPH_RST 0 = Reset asserted 1 = No reset	1	R
2	MASTER_RST	Current status of the MASTER_RST 0 = Reset asserted 1 = No reset	1	R
3	-	Reserved	1	
4	WWDT_RST	Current status of the WWDT_RS 0 = Reset asserted 1 = No reset	1	R
5	CREG_RST	Current status of the CREG_RST 0 = Reset asserted 1 = No reset	1	R
6	-	Reserved	1	
7	-	Reserved	1	
8	BUS_RST	Current status of the BUS_RST 0 = Reset asserted 1 = No reset	1	R
9	SCU_RST	Current status of the SCU_RST 0 = Reset asserted 1 = No reset	1	R
10	-	Reserved	1	-
11	-	Reserved	1	-

**Table 162. Reset active status register 0 (RESET_ACTIVE_STATUS0, address 0x4005 3150)
bit description ...continued**

Bit	Symbol	Description	Reset value	Access
12	-	Reserved	0	-
13	M3_RST	Current status of the M3_RST 0 = Reset asserted 1 = No reset	1	R
14	-	Reserved	1	
15	-	Reserved	1	
16	LCD_RST	Current status of the LCD_RST 0 = Reset asserted 1 = No reset	1	R
17	USB0_RST	Current status of the USB0_RST 0 = Reset asserted 1 = No reset	1	R
18	USB1_RST	Current status of the USB1_RST 0 = Reset asserted 1 = No reset	1	R
19	DMA_RST	Current status of the DMA_RST 0 = Reset asserted 1 = No reset	1	R
20	SDIO_RST	Current status of the SDIO_RST 0 = Reset asserted 1 = No reset	1	R
21	EMC_RST	Current status of the EMC_RST 0 = Reset asserted 1 = No reset	1	R
22	ETHERNET_RST	Current status of the ETHERNET_RST 0 = Reset asserted 1 = No reset	1	R
23	-	Reserved	1	-
24	-	Reserved	1	-
25	FLASHA_RST	Current status of the FLASHA_RST 0 = Reset asserted 1 = No reset	1	R
26	-	Reserved	1	-
27	EEPROM_RST	Current status of the EEPROM_RST 0 = Reset asserted 1 = No reset	1	R
28	GPIO_RST	Current status of the GPIO_RST 0 = Reset asserted 1 = No reset	1	R

Table 162. Reset active status register 0 (RESET_ACTIVE_STATUS0, address 0x4005 3150) bit description ...continued

Bit	Symbol	Description	Reset value	Access
29	FLASHB_RST	Current status of the FLASHB_RST 0 = Reset asserted 1 = No reset	1	R
30	-	Reserved	1	-
31	-	Reserved	1	-

Table 163. Reset active status register 1 (RESET_ACTIVE_STATUS1, address 0x4005 3154) bit description

Bit	Symbol	Description	Reset value	Access
0	TIMER0_RST	Current status of the TIMER0_RST 0 = Reset asserted 1 = No reset	1	R
1	TIMER1_RST	Current status of the TIMER1_RST 0 = Reset asserted 1 = No reset	1	R
2	TIMER2_RST	Current status of the TIMER2_RST 0 = Reset asserted 1 = No reset	1	R
3	TIMER3_RST	Current status of the TIMER3_RST 0 = Reset asserted 1 = No reset	1	R
4	RITIMER_RST	Current status of the RITIMER_RST 0 = Reset asserted 1 = No reset	1	R
5	SCT_RST	Current status of the SCT_RST 0 = Reset asserted 1 = No reset	1	R
6	MOTOCONPWM_RST	Current status of the MOTOCONPWM_RST 0 = Reset asserted 1 = No reset	1	R
7	QEI_RST	Current status of the QEI_RST 0 = Reset asserted 1 = No reset	1	R
8	ADC0_RST	Current status of the ADC0_RST 0 = Reset asserted 1 = No reset	1	R
9	ADC1_RST	Current status of the ADC1_RST 0 = Reset asserted 1 = No reset	1	R

**Table 163. Reset active status register 1 (RESET_ACTIVE_STATUS1, address 0x4005 3154)
bit description ...continued**

Bit	Symbol	Description	Reset value	Access
10	DAC_RST	Current status of the DAC_RST 0 = Reset asserted 1 = No reset	1	R
11	-		1	-
12	UART0_RST	Current status of the UART0_RST 0 = Reset asserted 1 = No reset	1	R
13	UART1_RST	Current status of the UART1_RST 0 = Reset asserted 1 = No reset	1	R
14	UART2_RST	Current status of the UART2_RST 0 = Reset asserted 1 = No reset	1	R
15	UART3_RST	Current status of the UART3_RST 0 = Reset asserted 1 = No reset	1	R
16	I2C0_RST	Current status of the I2C0_RST 0 = Reset asserted 1 = No reset	1	R
17	I2C1_RST	Current status of the I2C1_RST 0 = Reset asserted 1 = No reset	1	R
18	SSP0_RST	Current status of the SSP0_RST 0 = Reset asserted 1 = No reset	1	R
19	SSP1_RST	Current status of the SSP1_RST 0 = Reset asserted 1 = No reset	1	R
20	I2S_RST	Current status of the I2S_RST 0 = Reset asserted 1 = No reset	1	R
21	SPIFI_RST	Current status of the SPIFI_RST 0 = Reset asserted 1 = No reset	1	R
22	CAN1_RST	Current status of the CAN1_RST 0 = Reset asserted 1 = No reset	1	R
23	CAN0_RST	Current status of the CAN0_RST 0 = Reset asserted 1 = No reset	1	R
24	-	Reserved.	0	-

Table 163. Reset active status register 1 (RESET_ACTIVE_STATUS1, address 0x4005 3154) bit description ...continued

Bit	Symbol	Description	Reset value	Access
25	-	Reserved.	1	-
26	-	Reserved.	1	-
27	-	Reserved.	1	-
28	-	Reserved.	1	-
29	-	Reserved.	1	-
30	-	Reserved.	1	-
31	-	Reserved.	1	-

14.4.4 Reset external status registers

The external status registers indicate which input to the reset generator caused the reset output to go active. Any bit set to 1 in the Reset external status register should be cleared to 0 after a read operation to allow the detection of the next reset.

All reset generators except the WWDT time-out reset, the BOD reset, the reset signal from the PMC, and the software reset, which have no inputs, have an associated external status register. All reset generators have only one input which, depending on the hierarchy, can be either the CORE_RST, the PERIPHERAL_RST, or the MASTER_RST.

Note that the external status register does not show whether or not the reset was activated by a software reset. The software reset is indicated in the reset status registers 0 to 3 (see [Table 158](#) to [Table 161](#)).

14.4.4.1 Reset external status register 1 for PERIPH_RST

This register shows whether or not the CORE_RST output has activated the PERIPH_RST. A reset generated from the CORE_RST is the only possible reset source for the PERIPH_RST aside from a software reset by writing to the RESET_CTRL register.

Table 164. Reset external status register 1 (RESET_EXT_STAT1, address 0x4005 3404) bit description

Bit	Symbol	Description	Reset value	Access
0	-	Reserved. Do not modify; read as logic 0.	0	-
1	CORE_RESET	Reset activated by CORE_RST output. Write 0 to clear. 0 = Reset not activated 1 = Reset activated	0	R/W
31:2	-	Reserved. Do not modify; read as logic 0.	0	-

14.4.4.2 Reset external status register 2 for MASTER_RST

Table 165. Reset external status register 2 (RESET_EXT_STAT2, address 0x4005 3408) bit description

Bit	Symbol	Description	Reset value	Access
1:0	-	Reserved. Do not modify; read as logic 0.	0	-
2	PERIPHERAL_RESET	Reset activated by PERIPHERAL_RST output. Write 0 to clear. 0 = Reset not activated 1 = Reset activated	1	R/W
31:3	-	Reserved. Do not modify; read as logic 0.	0	-

14.4.4.3 Reset external status register 5 for CREG_RST

Table 166. Reset external status register 5 (RESET_EXT_STAT5, address 0x4005 3414) bit description

Bit	Symbol	Description	Reset value	Access
0	-	Reserved. Do not modify; read as logic 0.	0	-
1	CORE_RESET	Reset activated by CORE_RST output. Write 0 to clear. 0 = Reset not activated 1 = Reset activated	0	R/W
31:2	-	Reserved. Do not modify; read as logic 0.	0	-

14.4.4.4 Reset external status registers for PERIPHERAL_RESET

Refer to [Table 155](#) for reset generators which have the PERIPH_RST output as reset source.

Table 167. Reset external status registers x (RESET_EXT_STATx, address 0x4005 34xx) bit description

Bit	Symbol	Description	Reset value	Access
1:0	-	Reserved. Do not modify; read as logic 0.	0	-
2	PERIPHERAL_RESET	Reset activated by PERIPHERAL_RST output. Write 0 to clear. 0 = Reset not activated 1 = Reset activated	1	R/W
31:3	-	Reserved. Do not modify; read as logic 0.	0	-

14.4.4.5 Reset external status registers for MASTER_RESET

Refer to [Table 155](#) for reset generators which have the MASTER_RST output as reset source. These are the ARM Cortex-M3 core, the LCD controller, the USB0, the GPDMA, the SDIO controller, the external memory controller, and the Ethernet controller.

The reset value is dependent on the peripheral, see [Table 155](#).

Table 168. Reset external status registers y (RESET_EXT_STATy, address 0x4005 34yy) bit description

Bit	Symbol	Description	Reset value	Access
2:0	-	Reserved. Do not modify; read as logic 0.	0	-
3	MASTER_RESET	Reset activated by MASTER_RST output. Write 0 to clear. 0 = Reset not activated 1 = Reset activated	1	R/W
31:4	-	Reserved. Do not modify; read as logic 0.	0	-

14.5 Functional description

14.5.1 Determine the cause of a core reset

There are two different ways to determine the cause of a core reset:

1. Use a flag in internal RAM to determine the cause of a core reset.
 - a. Check the value of a flag at the start of execution. Possible flag values are:
 - i. $!=0xAA55\ FF01 \ \&\& \ !=0xAA55\ FF02 \rightarrow$ power on reset (POR)
 - ii. $0xAA55\ FF01 \rightarrow$ external reset signal (\overline{RESET})
 - iii. $0xAA55\ FF02 \rightarrow$ RGU generated core reset
 - b. After checking the flag, write a value of $0xAA55\ FF01$ to this flag.
 - c. Before performing an RGU generated core reset write a value of $0xAA55\ FF02$ to this flag.
2. Use bits in the event router registers to determine the cause of a core reset.
 - a. Check the state of the HILO, EDGE registers, and the RESET_E and RESET_ST bits in the EDGE and STATUS registers
 - i. $HILO==0 \ \& \ EDGE==0 \rightarrow$ power on reset
 - ii. $RESET_E==1 \ \&\& \ RESET_ST==1 \rightarrow$ external reset input (\overline{RESET})
 - b. Setup the event router to detect \overline{RESET} :
 - i. $RESET_L = 0$ // detect a low level (this is the bit's reset value)
 - ii. $RESET_E = 1$ // detect a falling edge
 - iii. $RESET_CLRST = 1$ // clear the previous event

15.1 How to read this chapter

For flashless parts LPC1850/30/20/10, see [Table 169](#). For flash-based parts LPC185x, see [Table 170](#).

15.2 Pin description

On the LPC18xx, digital pins are grouped into 16 pin groups, named P0 to P9 and PA to PF, with up to 20 pins used per group. Each digital pin may support up to eight different digital pin functions, including General-Purpose I/O (GPIO), selectable through the SCU pin configuration registers. Some digital pins support an additional analog function selectable through the ENAIO registers in the SCU (see [Section 16.4.6](#)). This analog function is not part of the eight-level pin multiplexer.

Remark: Note that the pin name is not indicative of the GPIO port assigned to it.

Remark: These parts contain two 10-bit ADCs (ADC0 and ADC1). The input channels of ADC0 and ADC1 on dedicated pins and multiplexed pins are combined in such a way that all channel 0 inputs (named ADC0_0 and ADC1_0) are tied together and connected to both, channel 0 on ADC0 and channel 0 on ADC1, channel 1 inputs (named ADC0_1 and ADC1_1) are tied together and connected to channel 1 on ADC0 and ADC1, and so forth. There are eight ADC channels total for the two ADCs.

Table 169. LPC1850/30/20/10 Pin description (flashless parts)

LCD, Ethernet, USB0, and USB1 functions are not available on all parts.

Symbol	LPGA256	TFBGA180	TFBGA100	LQFP144	Reset state [1]	Type	Description
Multiplexed digital pins							
P0_0	L3	K3	G2	32	[2]	N; PU	I/O GPIO0[0] — General purpose digital input/output pin.
							I/O SSP1_MISO — Master In Slave Out for SSP1.
							I ENET_RXD1 — Ethernet receive data 1 (RMII/MII interface).
							- R — Function reserved.
							- R — Function reserved.
							- R — Function reserved.
P0_1	M2	K2	G1	34	[2]	N; PU	I/O I2S0_TX_WS — Transmit Word Select. It is driven by the master and received by the slave. Corresponds to the signal WS in the <i>I²S-bus specification</i> .
							I/O I2S1_TX_WS — Transmit Word Select. It is driven by the master and received by the slave. Corresponds to the signal WS in the <i>I²S-bus specification</i> .
							I/O GPIO0[1] — General purpose digital input/output pin.
							I/O SSP1_MOSI — Master Out Slave in for SSP1.
P1_0	P2	L1	H1	38	[2]	N; PU	I ENET_COL — Ethernet Collision detect (MII interface).
							- R — Function reserved.
							- R — Function reserved.
							- R — Function reserved.
							ENET_TX_EN — Ethernet transmit enable (RMII/MII interface).
							I/O I2S1_TX_SDA — I ² S1 transmit data. It is driven by the transmitter and read by the receiver. Corresponds to the signal SD in the <i>I²S-bus specification</i> .
P1_0	P2	L1	H1	38	[2]	N; PU	I/O GPIO0[4] — General purpose digital input/output pin.
							I CTIN_3 — SCT input 3. Capture input 1 of timer 1.
							I/O EMC_A5 — External memory address line 5.
							- R — Function reserved.
							- R — Function reserved.
							I/O SSP0_SSEL — Slave Select for SSP0.
							- R — Function reserved.
							- R — Function reserved.

Table 169. LPC1850/30/20/10 Pin description (flashless parts) ...continued
 LCD, Ethernet, USB0, and USB1 functions are not available on all parts.

Symbol	LBGA256	TFBGA180	TFBGA100	LQFP144		Reset state [2]	[1]	Type	Description
P1_1	R2	N1	K2	42	[2]	N; PU		I/O	GPIO0[8] — General purpose digital input/output pin. Boot pin (see Table 16).
								O	CTOUT_7 — SCT output 7. Match output 3 of timer 1.
								I/O	EMC_A6 — External memory address line 6.
								-	R — Function reserved.
								-	R — Function reserved.
								I/O	SSP0_MISO — Master In Slave Out for SSP0.
								-	R — Function reserved.
P1_2	R3	N2	K1	43	[2]	N; PU		I/O	GPIO0[9] — General purpose digital input/output pin. Boot pin (see Table 16).
								O	CTOUT_6 — SCT output 6. Match output 2 of timer 1.
								I/O	EMC_A7 — External memory address line 7.
								-	R — Function reserved.
								-	R — Function reserved.
								I/O	SSP0_MOSI — Master Out Slave in for SSP0.
								-	R — Function reserved.
P1_3	P5	M2	J1	44	[2]	N; PU		I/O	GPIO0[10] — General purpose digital input/output pin.
								O	CTOUT_8 — SCT output 8. Match output 0 of timer 2.
								-	R — Function reserved.
								O	EMC_OE — LOW active Output Enable signal.
								O	USB0_IND1 — USB0 port indicator LED control output 1.
								I/O	SSP1_MISO — Master In Slave Out for SSP1.
								-	R — Function reserved.
O	SD_RST — SD/MMC reset signal for MMC4.4 card.								
P1_4	T3	P2	J2	47	[2]	N; PU		I/O	GPIO0[11] — General purpose digital input/output pin.
								O	CTOUT_9 — SCT output 9. Match output 3 of timer 3.
								-	R — Function reserved.
								O	EMC_BLS0 — LOW active Byte Lane select signal 0.
								O	USB0_IND0 — USB0 port indicator LED control output 0.
								I/O	SSP1_MOSI — Master Out Slave in for SSP1.
								-	R — Function reserved.
O	SD_VOLT1 — SD/MMC bus voltage select output 1.								

Table 169. LPC1850/30/20/10 Pin description (flashless parts) ...continued
 LCD, Ethernet, USB0, and USB1 functions are not available on all parts.

Symbol	LBGA256	TFBGA180	TFBGA100	LQFP144		Reset state [1]	Type	Description
P1_5	R5	N3	J4	48	[2]	N; PU	I/O	GPIO1[8] — General purpose digital input/output pin.
							O	CTOUT_10 — SCT output 10. Match output 3 of timer 3.
							-	R — Function reserved.
							O	EMC_CS0 — LOW active Chip Select 0 signal.
							I	USB0_PWR_FAULT — Port power fault signal indicating overcurrent condition; this signal monitors over-current on the USB bus (external circuitry required to detect over-current condition).
							I/O	SSP1_SSEL — Slave Select for SSP1.
							-	R — Function reserved.
P1_6	T4	P3	K4	49	[2]	N; PU	I/O	GPIO1[9] — General purpose digital input/output pin.
							I	CTIN_5 — SCT input 5. Capture input 2 of timer 2.
							-	R — Function reserved.
							O	EMC_WE — LOW active Write Enable signal.
							-	R — Function reserved.
							-	R — Function reserved.
							-	R — Function reserved.
P1_7	T5	N4	G4	50	[2]	N; PU	I/O	GPIO1[0] — General purpose digital input/output pin.
							I	U1_DSR — Data Set Ready input for UART1.
							O	CTOUT_13 — SCT output 13. Match output 3 of timer 3.
							I/O	EMC_D0 — External memory data line 0.
							O	USB0_PPWR — VBUS drive signal (towards external charge pump or power management unit); indicates that VBUS must be driven (active HIGH). Add a pull-down resistor to disable the power switch at reset. This signal has opposite polarity compared to the USB_PPWR used on other NXP LPC parts.
							-	R — Function reserved.
							-	R — Function reserved.
-	R — Function reserved.							

Table 169. LPC1850/30/20/10 Pin description (flashless parts) ...continued
 LCD, Ethernet, USB0, and USB1 functions are not available on all parts.

Symbol	LBGA256	TFBGA180	TFBGA100	LQFP144		Reset state [1]	Type	Description
P1_8	R7	M5	H5	51	[2]	N; PU	I/O	GPIO1[1] — General purpose digital input/output pin.
							O	U1_DTR — Data Terminal Ready output for UART1.
							O	CTOUT_12 — SCT output 12. Match output 3 of timer 3.
							I/O	EMC_D1 — External memory data line 1.
							-	R — Function reserved.
							-	R — Function reserved.
P1_9	T7	N5	J5	52	[2]	N; PU	I/O	GPIO1[2] — General purpose digital input/output pin.
							O	U1_RTS — Request to Send output for UART1.
							O	CTOUT_11 — SCT output 11. Match output 3 of timer 2.
							I/O	EMC_D2 — External memory data line 2.
							-	R — Function reserved.
							-	R — Function reserved.
P1_10	R8	N6	H6	53	[2]	N; PU	I/O	GPIO1[3] — General purpose digital input/output pin.
							I	U1_RI — Ring Indicator input for UART1.
							O	CTOUT_14 — SCT output 14. Match output 2 of timer 3.
							I/O	EMC_D3 — External memory data line 3.
							-	R — Function reserved.
							-	R — Function reserved.
P1_11	T9	P8	J7	55	[2]	N; PU	I/O	GPIO1[4] — General purpose digital input/output pin.
							I	U1_CTS — Clear to Send input for UART1.
							O	CTOUT_15 — SCT output 15. Match output 3 of timer 3.
							I/O	EMC_D4 — External memory data line 4.
							-	R — Function reserved.
							-	R — Function reserved.
							I/O	SD_DAT2 — SD/MMC data bus line 2.

Table 169. LPC1850/30/20/10 Pin description (flashless parts) ...continued
 LCD, Ethernet, USB0, and USB1 functions are not available on all parts.

Symbol	LBGA256	TFBGA180	TFBGA100	LQFP144		Reset state [1]	Type	Description
P1_12	R9	P7	K7	56	[2]	N; PU	I/O	GPIO1[5] — General purpose digital input/output pin.
							I	U1_DCD — Data Carrier Detect input for UART1.
							-	R — Function reserved.
							I/O	EMC_D5 — External memory data line 5.
							I	T0_CAP1 — Capture input 1 of timer 0.
							-	R — Function reserved.
-	R — Function reserved.							
-	R — Function reserved.							
I/O	SD_DAT3 — SD/MMC data bus line 3.							
P1_13	R10	L8	H8	60	[2]	N; PU	I/O	GPIO1[6] — General purpose digital input/output pin.
							O	U1_TXD — Transmitter output for UART1.
							-	R — Function reserved.
							I/O	EMC_D6 — External memory data line 6.
							I	T0_CAP0 — Capture input 0 of timer 0.
							-	R — Function reserved.
-	R — Function reserved.							
I	SD_CD — SD/MMC card detect input.							
P1_14	R11	K7	J8	61	[2]	N; PU	I/O	GPIO1[7] — General purpose digital input/output pin.
							I	U1_RXD — Receiver input for UART1.
							-	R — Function reserved.
							I/O	EMC_D7 — External memory data line 7.
							O	T0_MAT2 — Match output 2 of timer 0.
							-	R — Function reserved.
-	R — Function reserved.							
-	R — Function reserved.							
P1_15	T12	P11	K8	62	[2]	N; PU	I/O	GPIO0[2] — General purpose digital input/output pin.
							O	U2_TXD — Transmitter output for USART2.
							-	R — Function reserved.
							I	ENET_RXD0 — Ethernet receive data 0 (RMII/MII interface).
							O	T0_MAT1 — Match output 1 of timer 0.
							-	R — Function reserved.
-	R — Function reserved.							
-	R — Function reserved.							

Table 169. LPC1850/30/20/10 Pin description (flashless parts) ...continued
LCD, Ethernet, USB0, and USB1 functions are not available on all parts.

Symbol	LBGA256	TFBGA180	TFBGA100	LQFP144		Reset state [1]	Type	Description
P1_16	M7	L5	H9	64	[2]	N; PU	I/O	GPIO0[3] — General purpose digital input/output pin.
							I	U2_RXD — Receiver input for USART2.
							-	R — Function reserved.
							I	ENET_CRS — Ethernet Carrier Sense (MII interface).
							O	T0_MAT0 — Match output 0 of timer 0.
							-	R — Function reserved.
							-	R — Function reserved.
P1_17	M8	L6	H10	66	[3]	N; PU	I/O	GPIO0[12] — General purpose digital input/output pin.
							I/O	U2_UCLK — Serial clock input/output for USART2 in synchronous mode.
							-	R — Function reserved.
							I/O	ENET_MDIO — Ethernet MIIM data input and output.
							I	T0_CAP3 — Capture input 3 of timer 0.
							O	CAN1_TD — CAN1 transmitter output.
							-	R — Function reserved.
-	R — Function reserved.							
P1_18	N12	N10	J10	67	[2]	N; PU	I/O	GPIO0[13] — General purpose digital input/output pin.
							I/O	U2_DIR — RS-485/EIA-485 output enable/direction control for USART2.
							-	R — Function reserved.
							O	ENET_TXD0 — Ethernet transmit data 0 (RMII/MII interface).
							O	T0_MAT3 — Match output 3 of timer 0.
							I	CAN1_RD — CAN1 receiver input.
							-	R — Function reserved.
-	R — Function reserved.							
P1_19	M11	N9	K9	68	[2]	N; PU	I	ENET_TX_CLK (ENET_REF_CLK) — Ethernet Transmit Clock (MII interface) or Ethernet Reference Clock (RMII interface).
							I/O	SSP1_SCK — Serial clock for SSP1.
							-	R — Function reserved.
							-	R — Function reserved.
							O	CLKOUT — Clock output pin.
							-	R — Function reserved.
							O	I2S0_RX_MCLK — I ² S receive master clock.
I/O	I2S1_TX_SCK — Transmit Clock. It is driven by the master and received by the slave. Corresponds to the signal SCK in the I ² S-bus specification.							

Table 169. LPC1850/30/20/10 Pin description (flashless parts) ...continued
 LCD, Ethernet, USB0, and USB1 functions are not available on all parts.

Symbol	LPGA256	TFBGA180	TFBGA100	LQFP144		Reset state	Description							
						[1]	Type							
P1_20	M10	J10	K10	70	[2]	N; PU	I/O GPIO0[15] — General purpose digital input/output pin.							
							I/O SSP1_SSEL — Slave Select for SSP1.							
							- R — Function reserved.							
							O ENET_TXD1 — Ethernet transmit data 1 (RMII/MII interface).							
							I T0_CAP2 — Capture input 2 of timer 0.							
							- R — Function reserved.							
P2_0	T16	N14	G10	75	[2]	N; PU	- R — Function reserved.							
							O U0_TXD — Transmitter output for USART0.							
							I/O EMC_A13 — External memory address line 13.							
							O USB0_PPWR — VBUS drive signal (towards external charge pump or power management unit); indicates that VBUS must be driven (active high). Add a pull-down resistor to disable the power switch at reset. This signal has opposite polarity compared to the USB_PPWR used on other NXP LPC parts.							
							I/O GPIO5[0] — General purpose digital input/output pin.							
							- R — Function reserved.							
							I T3_CAP0 — Capture input 0 of timer 3.							
							O ENET_MDC — Ethernet MIIM clock.							
							P2_1	N15	M13	G7	81	[2]	N; PU	- R — Function reserved.
														I U0_RXD — Receiver input for USART0.
														I/O EMC_A12 — External memory address line 12.
I USB0_PWR_FAULT — Port power fault signal indicating overcurrent condition; this signal monitors over-current on the USB bus (external circuitry required to detect over-current condition).														
I/O GPIO5[1] — General purpose digital input/output pin.														
- R — Function reserved.														
I T3_CAP1 — Capture input 1 of timer 3.														
- R — Function reserved.														

Table 169. LPC1850/30/20/10 Pin description (flashless parts) ...continued
 LCD, Ethernet, USB0, and USB1 functions are not available on all parts.

Symbol	LPGA256	TFBGA180	TFBGA100	LQFP144		Reset state	Type	Description
P2_2	M15	L13	F5	84	[2]	N; PU	-	R — Function reserved.
							I/O	U0_UCLK — Serial clock input/output for USART0 in synchronous mode.
							I/O	EMC_A11 — External memory address line 11.
							O	USB0_IND1 — USB0 port indicator LED control output 1.
							I/O	GPIO5[2] — General purpose digital input/output pin.
							I	CTIN_6 — SCT input 6. Capture input 1 of timer 3.
							I	T3_CAP2 — Capture input 2 of timer 3.
P2_3	J12	G11	D8	87	[3]	N; PU	-	R — Function reserved.
							I/O	I2C1_SDA — I ² C1 data input/output (this pin does not use a specialized I ² C pad).
							O	U3_TXD — Transmitter output for USART3.
							I	CTIN_1 — SCT input 1. Capture input 1 of timer 0. Capture input 1 of timer 2.
							I/O	GPIO5[3] — General purpose digital input/output pin.
							-	R — Function reserved.
							O	T3_MAT0 — Match output 0 of timer 3.
O	USB0_PPWR — VBUS drive signal (towards external charge pump or power management unit); indicates that VBUS must be driven (active HIGH). Add a pull-down resistor to disable the power switch at reset. This signal has opposite polarity compared to the USB_PPWR used on other NXP LPC parts.							
P2_4	K11	L9	D9	88	[3]	N; PU	-	R — Function reserved.
							I/O	I2C1_SCL — I ² C1 clock input/output (this pin does not use a specialized I ² C pad).
							I	U3_RXD — Receiver input for USART3.
							I	CTIN_0 — SCT input 0. Capture input 0 of timer 0, 1, 2, 3.
							I/O	GPIO5[4] — General purpose digital input/output pin.
							-	R — Function reserved.
							O	T3_MAT1 — Match output 1 of timer 3.
I	USB0_PWR_FAULT — Port power fault signal indicating overcurrent condition; this signal monitors over-current on the USB bus (external circuitry required to detect over-current condition).							

Table 169. LPC1850/30/20/10 Pin description (flashless parts) ...continued
 LCD, Ethernet, USB0, and USB1 functions are not available on all parts.

Symbol	LBGA256	TFBGA180	TFBGA100	LQFP144		Reset state [1]	Type	Description
P2_5	K14	J12	D10	91	[3]	N; PU	-	R — Function reserved.
							I	CTIN_2 — SCT input 2. Capture input 2 of timer 0.
							I	USB1_VBUS — Monitors the presence of USB1 bus power. Note: This signal must be HIGH for USB reset to occur.
							I	ADCTRIG1 — ADC trigger input 1.
							I/O	GPIO5[5] — General purpose digital input/output pin.
							-	R — Function reserved.
							O	T3_MAT2 — Match output 2 of timer 3.
							O	USB0_IND0 — USB0 port indicator LED control output 0.
P2_6	K16	J14	G9	95	[2]	N; PU	-	R — Function reserved.
							I/O	U0_DIR — RS-485/EIA-485 output enable/direction control for USART0.
							I/O	EMC_A10 — External memory address line 10.
							O	USB0_IND0 — USB0 port indicator LED control output 0.
							I/O	GPIO5[6] — General purpose digital input/output pin.
							I	CTIN_7 — SCT input 7.
P2_7	H14	G12	C10	96	[2]	N; PU	I/O	GPIO0[7] — General purpose digital input/output pin. ISP entry pin. If this pin is pulled LOW at reset, the part enters ISP mode using USART0.
							O	CTOUT_1 — SCT output 1. Match output 3 of timer 3.
							I/O	U3_UCLK — Serial clock input/output for USART3 in synchronous mode.
							I/O	EMC_A9 — External memory address line 9.
							-	R — Function reserved.
							-	R — Function reserved.
							O	T3_MAT3 — Match output 3 of timer 3.
							-	R — Function reserved.

Table 169. LPC1850/30/20/10 Pin description (flashless parts) ...continued
 LCD, Ethernet, USB0, and USB1 functions are not available on all parts.

Symbol	LBGA256	TFBGA180	TFBGA100	LQFP144		Reset state [1]	Type	Description
P2_8	J16	H14	C6	98	[2]	N; PU	-	R — Function reserved. Boot pin (see Table 16)
							O	CTOUT_0 — SCT output 0. Match output 0 of timer 0.
							I/O	U3_DIR — RS-485/EIA-485 output enable/direction control for USART3.
							I/O	EMC_A8 — External memory address line 8.
							I/O	GPIO5[7] — General purpose digital input/output pin.
							-	R — Function reserved.
							-	R — Function reserved.
P2_9	H16	G14	B10	102	[2]	N; PU	I/O	GPIO1[10] — General purpose digital input/output pin. Boot pin (see Table 16).
							O	CTOUT_3 — SCT output 3. Match output 3 of timer 0.
							I/O	U3_BAUD — Baud pin for USART3.
							I/O	EMC_A0 — External memory address line 0.
							-	R — Function reserved.
							-	R — Function reserved.
							-	R — Function reserved.
P2_10	G16	F14	E8	104	[2]	N; PU	I/O	GPIO0[14] — General purpose digital input/output pin.
							O	CTOUT_2 — SCT output 2. Match output 2 of timer 0.
							O	U2_TXD — Transmitter output for USART2.
							I/O	EMC_A1 — External memory address line 1.
							-	R — Function reserved.
							-	R — Function reserved.
							-	R — Function reserved.
P2_11	F16	E13	A9	105	[2]	N; PU	I/O	GPIO1[11] — General purpose digital input/output pin.
							O	CTOUT_5 — SCT output 5. Match output 3 of timer 3.
							I	U2_RXD — Receiver input for USART2.
							I/O	EMC_A2 — External memory address line 2.
							-	R — Function reserved.
							-	R — Function reserved.
							-	R — Function reserved.

Table 169. LPC1850/30/20/10 Pin description (flashless parts) ...continued
 LCD, Ethernet, USB0, and USB1 functions are not available on all parts.

Symbol	LBGA256	TFBGA180	TFBGA100	LQFP144		Reset state [1]	Type	Description
P2_12	E15	D13	B9	106	[2]	N; PU	I/O	GPIO1[12] — General purpose digital input/output pin.
							O	CTOUT_4 — SCT output 4. Match output 3 of timer 3.
							-	R — Function reserved.
							I/O	EMC_A3 — External memory address line 3.
							-	R — Function reserved.
							-	R — Function reserved.
							-	R — Function reserved.
P2_13	C16	E14	A10	108	[2]	N; PU	I/O	GPIO1[13] — General purpose digital input/output pin.
							I	CTIN_4 — SCT input 4. Capture input 2 of timer 1.
							-	R — Function reserved.
							I/O	EMC_A4 — External memory address line 4.
							-	R — Function reserved.
							-	R — Function reserved.
							-	R — Function reserved.
P3_0	F13	D12	A8	112	[2]	N; PU	I/O	I2S0_RX_SCK — I ² S receive clock. It is driven by the master and received by the slave. Corresponds to the signal SCK in the <i>I²S-bus specification</i> .
							O	I2S0_RX_MCLK — I ² S receive master clock.
							I/O	I2S0_TX_SCK — Transmit Clock. It is driven by the master and received by the slave. Corresponds to the signal SCK in the <i>I²S-bus specification</i> .
							O	I2S0_TX_MCLK — I ² S transmit master clock.
							I/O	SSP0_SCK — Serial clock for SSP0.
							-	R — Function reserved.
							-	R — Function reserved.
-	R — Function reserved.							

Table 169. LPC1850/30/20/10 Pin description (flashless parts) ...continued
 LCD, Ethernet, USB0, and USB1 functions are not available on all parts.

Symbol	LBGA256	TFBGA180	TFBGA100	LQFP144	Reset state	Type	Description
P3_1	G11	D10	F7	114	N; PU	I/O	I2S0_TX_WS — Transmit Word Select. It is driven by the master and received by the slave. Corresponds to the signal WS in the <i>I²S-bus specification</i> .
							I/O I2S0_RX_WS — Receive Word Select. It is driven by the master and received by the slave. Corresponds to the signal WS in the <i>I²S-bus specification</i> .
							I CAN0_RD — CAN receiver input.
							O USB1_IND1 — USB1 Port indicator LED control output 1.
							I/O GPIO5[8] — General purpose digital input/output pin.
							- R — Function reserved.
							O LCD_VD15 — LCD data.
P3_2	F11	D9	G6	116	OL; PU	I/O	I2S0_TX_SDA — I ² S transmit data. It is driven by the transmitter and read by the receiver. Corresponds to the signal SD in the <i>I²S-bus specification</i> .
							I/O I2S0_RX_SDA — I ² S receive data. It is driven by the transmitter and read by the receiver. Corresponds to the signal SD in the <i>I²S-bus specification</i> .
							O CAN0_TD — CAN transmitter output.
							O USB1_IND0 — USB1 Port indicator LED control output 0.
							I/O GPIO5[9] — General purpose digital input/output pin.
							- R — Function reserved.
							O LCD_VD14 — LCD data.
P3_3	B14	B13	A7	118	N; PU	-	R — Function reserved.
							R — Function reserved.
							I/O SSP0_SCK — Serial clock for SSP0.
							O SPIFI_SCK — Serial clock for SPIFI.
							O CGU_OUT1 — CGU spare clock output 1.
							- R — Function reserved.
							O I2S0_TX_MCLK — I ² S transmit master clock.
I/O I2S1_TX_SCK — Transmit Clock. It is driven by the master and received by the slave. Corresponds to the signal SCK in the <i>I²S-bus specification</i> .							

Table 169. LPC1850/30/20/10 Pin description (flashless parts) ...continued
 LCD, Ethernet, USB0, and USB1 functions are not available on all parts.

Symbol	LBGA256	TFBGA180	TFBGA100	LQFP144		Reset state	Type	Description
P3_4	A15	C14	B8	119	[2]	N; PU	I/O	GPIO1[14] — General purpose digital input/output pin.
								- R — Function reserved.
								- R — Function reserved.
								I/O SPIFI_SIO3 — I/O lane 3 for SPIFI.
								O U1_TXD — Transmitter output for UART1.
								I/O I2S0_TX_WS — Transmit Word Select. It is driven by the master and received by the slave. Corresponds to the signal WS in the <i>I²S-bus specification</i> .
								I/O I2S1_RX_SDA — I ² S1 receive data. It is driven by the transmitter and read by the receiver. Corresponds to the signal SD in the <i>I²S-bus specification</i> .
O LCD_VD13 — LCD data.								
P3_5	C12	C11	B7	121	[2]	N; PU	I/O	GPIO1[15] — General purpose digital input/output pin.
								- R — Function reserved.
								- R — Function reserved.
								I/O SPIFI_SIO2 — I/O lane 2 for SPIFI.
								I U1_RXD — Receiver input for UART1.
								I/O I2S0_TX_SDA — I ² S transmit data. It is driven by the transmitter and read by the receiver. Corresponds to the signal SD in the <i>I²S-bus specification</i> .
								I/O I2S1_RX_WS — Receive Word Select. It is driven by the master and received by the slave. Corresponds to the signal WS in the <i>I²S-bus specification</i> .
O LCD_VD12 — LCD data.								
P3_6	B13	B12	C7	122	[2]	N; PU	I/O	GPIO0[6] — General purpose digital input/output pin.
								- R — Function reserved.
								I/O SSP0_SSEL — Slave Select for SSP0.
								I/O SPIFI_MISO — Input 1 in SPIFI quad mode; SPIFI output IO1.
								- R — Function reserved.
								I/O SSP0_MISO — Master In Slave Out for SSP0.
								- R — Function reserved.
- R — Function reserved.								

Table 169. LPC1850/30/20/10 Pin description (flashless parts) ...continued
 LCD, Ethernet, USB0, and USB1 functions are not available on all parts.

Symbol	LBGA256	TFBGA180	TFBGA100	LQFP144		Reset state [1]	Type	Description
P3_7	C11	C10	D7	123	[2]	N; PU	-	R — Function reserved.
							-	R — Function reserved.
							I/O	SSP0_MISO — Master In Slave Out for SSP0.
							I/O	SPIFI_MOSI — Input 0 in SPIFI quad mode; SPIFI output IO0.
							I/O	GPIO5[10] — General purpose digital input/output pin.
							I/O	SSP0_MOSI — Master Out Slave in for SSP0.
							-	R — Function reserved.
P3_8	C10	C9	E7	124	[2]	N; PU	-	R — Function reserved.
							-	R — Function reserved.
							I/O	SSP0_MOSI — Master Out Slave in for SSP0.
							I/O	SPIFI_CS — SPIFI serial flash chip select.
							I/O	GPIO5[11] — General purpose digital input/output pin.
							I/O	SSP0_SSEL — Slave Select for SSP0.
							-	R — Function reserved.
P4_0	D5	D4	-	1	[2]	N; PU	I/O	GPIO2[0] — General purpose digital input/output pin.
							O	MCOA0 — Motor control PWM channel 0, output A.
							I	NMI — External interrupt input to NMI.
							-	R — Function reserved.
							-	R — Function reserved.
							O	LCD_VD13 — LCD data.
							I/O	U3_UCLK — Serial clock input/output for USART3 in synchronous mode.
-	R — Function reserved.							
P4_1	A1	D3	-	3	[5]	N; PU	I/O	GPIO2[1] — General purpose digital input/output pin.
							O	CTOUT_1 — SCT output 3. Match output 3 of timer 3.
							O	LCD_VD0 — LCD data.
							-	R — Function reserved.
							-	R — Function reserved.
							O	LCD_VD19 — LCD data.
							O	U3_TXD — Transmitter output for USART3.
I	ENET_COL — Ethernet Collision detect (MII interface).							
AI	ADC0_1 — ADC0 and ADC1, input channel 1. Configure the pin as GPIO input and use the ADC function select register in the SCU to select the ADC.							

Table 169. LPC1850/30/20/10 Pin description (flashless parts) ...continued
 LCD, Ethernet, USB0, and USB1 functions are not available on all parts.

Symbol	LBGA256	TFBGA180	TFBGA100	LQFP144	Reset state [1]	Type	Description
P4_2	D3	A2	-	8	[2]	N; PU	I/O GPIO2[2] — General purpose digital input/output pin.
							O CTOUT_0 — SCT output 0. Match output 0 of timer 0.
							O LCD_VD3 — LCD data.
							- R — Function reserved.
							- R — Function reserved.
							O LCD_VD12 — LCD data.
							I U3_RXD — Receiver input for USART3.
- R — Function reserved.							
P4_3	C2	B2	-	7	[5]	N; PU	I/O GPIO2[3] — General purpose digital input/output pin.
							O CTOUT_3 — SCT output 3. Match output 3 of timer 0.
							O LCD_VD2 — LCD data.
							- R — Function reserved.
							- R — Function reserved.
							O LCD_VD21 — LCD data.
							I/O U3_BAUD — Baud pin for USART3.
- R — Function reserved.							
AI ADC0_0 — DAC out, ADC0 and ADC1, input channel 0. Configure the pin as GPIO input and use the ADC function select register in the SCU to select the ADC.							
P4_4	B1	A1	-	9	[5]	N; PU	I/O GPIO2[4] — General purpose digital input/output pin.
							O CTOUT_2 — SCT output 2. Match output 2 of timer 0.
							O LCD_VD1 — LCD data.
							- R — Function reserved.
							- R — Function reserved.
							O LCD_VD20 — LCD data.
							I/O U3_DIR — RS-485/EIA-485 output enable/direction control for USART3.
- R — Function reserved.							
AO DAC — DAC output. Shared between 10-bit ADC0/1 and DAC. Configure the pin as GPIO input and use the analog function select register in the SCU to select the DAC.							

Table 169. LPC1850/30/20/10 Pin description (flashless parts) ...continued
 LCD, Ethernet, USB0, and USB1 functions are not available on all parts.

Symbol	LBGA256	TFBGA180	TFBGA100	LQFP144		Reset state [2]	Type	Description
P4_5	D2	C2	-	10	[2]	N; PU	I/O	GPIO2[5] — General purpose digital input/output pin.
							O	CTOUT_5 — SCT output 5. Match output 3 of timer 3.
							O	LCD_FP — Frame pulse (STN). Vertical synchronization pulse (TFT).
							-	R — Function reserved.
							-	R — Function reserved.
							-	R — Function reserved.
							-	R — Function reserved.
P4_6	C1	B1	-	11	[2]	N; PU	I/O	GPIO2[6] — General purpose digital input/output pin.
							O	CTOUT_4 — SCT output 4. Match output 3 of timer 3.
							O	LCD_ENAB/LCDM — STN AC bias drive or TFT data enable input.
							-	R — Function reserved.
							-	R — Function reserved.
							-	R — Function reserved.
							-	R — Function reserved.
P4_7	H4	F4	-	14	[2]	O; PU	O	LCD_DCLK — LCD panel clock.
							I	GP_CLKIN — General purpose clock input to the CGU.
							-	R — Function reserved.
							-	R — Function reserved.
							-	R — Function reserved.
							-	R — Function reserved.
							I/O	I2S1_TX_SCK — Transmit Clock. It is driven by the master and received by the slave. Corresponds to the signal SCK in the <i>I²S-bus specification</i> .
I/O	I2S0_TX_SCK — Transmit Clock. It is driven by the master and received by the slave. Corresponds to the signal SCK in the <i>I²S-bus specification</i> .							
P4_8	E2	D2	-	15	[2]	N; PU	-	R — Function reserved.
							I	CTIN_5 — SCT input 5. Capture input 2 of timer 2.
							O	LCD_VD9 — LCD data.
							-	R — Function reserved.
							I/O	GPIO5[12] — General purpose digital input/output pin.
							O	LCD_VD22 — LCD data.
							O	CAN1_TD — CAN1 transmitter output.
-	R — Function reserved.							

Table 169. LPC1850/30/20/10 Pin description (flashless parts) ...continued
 LCD, Ethernet, USB0, and USB1 functions are not available on all parts.

Symbol	LBGA256	TFBGA180	TFBGA100	LQFP144	Reset state	Type	Description
P4_9	L2	J2	-	33	N; PU	-	R — Function reserved.
						I	CTIN_6 — SCT input 6. Capture input 1 of timer 3.
						O	LCD_VD11 — LCD data.
						-	R — Function reserved.
						I/O	GPIO5[13] — General purpose digital input/output pin.
						O	LCD_VD15 — LCD data.
						I	CAN1_RD — CAN1 receiver input.
P4_10	M3	L3	-	35	N; PU	-	R — Function reserved.
						I	CTIN_2 — SCT input 2. Capture input 2 of timer 0.
						O	LCD_VD10 — LCD data.
						-	R — Function reserved.
						I/O	GPIO5[14] — General purpose digital input/output pin.
						O	LCD_VD14 — LCD data.
						-	R — Function reserved.
P5_0	N3	L2	-	37	N; PU	I/O	GPIO2[9] — General purpose digital input/output pin.
						O	MCOB2 — Motor control PWM channel 2, output B.
						I/O	EMC_D12 — External memory data line 12.
						-	R — Function reserved.
						I	U1_DSR — Data Set Ready input for UART1.
						I	T1_CAP0 — Capture input 0 of timer 1.
						-	R — Function reserved.
P5_1	P3	M1	-	39	N; PU	I/O	GPIO2[10] — General purpose digital input/output pin.
						I	MC12 — Motor control PWM channel 2, input.
						I/O	EMC_D13 — External memory data line 13.
						-	R — Function reserved.
						O	U1_DTR — Data Terminal Ready output for UART1. Can also be configured to be an RS-485/EIA-485 output enable signal for UART1.
						I	T1_CAP1 — Capture input 1 of timer 1.
						-	R — Function reserved.
-	R — Function reserved.						

Table 169. LPC1850/30/20/10 Pin description (flashless parts) ...continued
 LCD, Ethernet, USB0, and USB1 functions are not available on all parts.

Symbol	LBGA256	TFBGA180	TFBGA100	LQFP144		Reset state [1]	Type	Description
P5_2	R4	M3	-	46	[2]	N; PU	I/O	GPIO2[11] — General purpose digital input/output pin.
							I	MC11 — Motor control PWM channel 1, input.
							I/O	EMC_D14 — External memory data line 14.
							-	R — Function reserved.
							O	U1_RTS — Request to Send output for UART1. Can also be configured to be an RS-485/EIA-485 output enable signal for UART1.
							I	T1_CAP2 — Capture input 2 of timer 1.
							-	R — Function reserved.
P5_3	T8	P6	-	54	[2]	N; PU	I/O	GPIO2[12] — General purpose digital input/output pin.
							I	MC10 — Motor control PWM channel 0, input.
							I/O	EMC_D15 — External memory data line 15.
							-	R — Function reserved.
							I	U1_RI — Ring Indicator input for UART1.
							I	T1_CAP3 — Capture input 3 of timer 1.
							-	R — Function reserved.
P5_4	P9	N7	-	57	[2]	N; PU	I/O	GPIO2[13] — General purpose digital input/output pin.
							O	MCOB0 — Motor control PWM channel 0, output B.
							I/O	EMC_D8 — External memory data line 8.
							-	R — Function reserved.
							I	U1_CTS — Clear to Send input for UART1.
							O	T1_MAT0 — Match output 0 of timer 1.
							-	R — Function reserved.
P5_5	P10	N8	-	58	[2]	N; PU	I/O	GPIO2[14] — General purpose digital input/output pin.
							O	MCOA1 — Motor control PWM channel 1, output A.
							I/O	EMC_D9 — External memory data line 9.
							-	R — Function reserved.
							I	U1_DCD — Data Carrier Detect input for UART1.
							O	T1_MAT1 — Match output 1 of timer 1.
							-	R — Function reserved.
-	R — Function reserved.							

Table 169. LPC1850/30/20/10 Pin description (flashless parts) ...continued
 LCD, Ethernet, USB0, and USB1 functions are not available on all parts.

Symbol	LBGA256	TFBGA180	TFBGA100	LQFP144		Reset state [1]	Type	Description
P5_6	T13	M11	-	63	[2]	N; PU	I/O	GPIO2[15] — General purpose digital input/output pin.
							O	MCOB1 — Motor control PWM channel 1, output B.
							I/O	EMC_D10 — External memory data line 10.
							-	R — Function reserved.
							O	U1_TXD — Transmitter output for UART1.
							O	T1_MAT2 — Match output 2 of timer 1.
							-	R — Function reserved.
P5_7	R12	N11	-	65	[2]	N; PU	I/O	GPIO2[7] — General purpose digital input/output pin.
							O	MCOA2 — Motor control PWM channel 2, output A.
							I/O	EMC_D11 — External memory data line 11.
							-	R — Function reserved.
							I	U1_RXD — Receiver input for UART1.
							O	T1_MAT3 — Match output 3 of timer 1.
							-	R — Function reserved.
P6_0	M12	M10	H7	73	[2]	N; PU	-	R — Function reserved.
							O	I2S0_RX_MCLK — I ² S receive master clock.
							-	R — Function reserved.
							-	R — Function reserved.
							I/O	I2S0_RX_SCK — Receive Clock. It is driven by the master and received by the slave. Corresponds to the signal SCK in the <i>I²S-bus specification</i> .
							-	R — Function reserved.
							-	R — Function reserved.
P6_1	R15	P14	G5	74	[2]	N; PU	I/O	GPIO3[0] — General purpose digital input/output pin.
							O	EMC_DYCS1 — SDRAM chip select 1.
							I/O	U0_UCLK — Serial clock input/output for USART0 in synchronous mode.
							I/O	I2S0_RX_WS — Receive Word Select. It is driven by the master and received by the slave. Corresponds to the signal WS in the <i>I²S-bus specification</i> .
							-	R — Function reserved.
							I	T2_CAP0 — Capture input 0 of timer 2.
							-	R — Function reserved.
-	R — Function reserved.							

Table 169. LPC1850/30/20/10 Pin description (flashless parts) ...continued
 LCD, Ethernet, USB0, and USB1 functions are not available on all parts.

Symbol	LPGA256	TFBGA180	TFBGA100	LQFP144		Reset state [1]	Type	Description
P6_2	L13	K11	J9	78	[2]	N; PU	I/O	GPIO3[1] — General purpose digital input/output pin.
							O	EMC_CKEOUT1 — SDRAM clock enable 1.
							I/O	U0_DIR — RS-485/EIA-485 output enable/direction control for USART0.
							I/O	I2S0_RX_SDA — I ² S Receive data. It is driven by the transmitter and read by the receiver. Corresponds to the signal SD in the <i>I²S-bus specification</i> .
							-	R — Function reserved.
							I	T2_CAP1 — Capture input 1 of timer 2.
							-	R — Function reserved.
P6_3	P15	N13	-	79	[2]	N; PU	I/O	GPIO3[2] — General purpose digital input/output pin.
							O	USB0_PPWR — VBUS drive signal (towards external charge pump or power management unit); indicates that the VBUS signal must be driven (active HIGH). Add a pull-down resistor to disable the power switch at reset. This signal has opposite polarity compared to the <u>USB_PPWR</u> used on other NXP LPC parts.
							-	R — Function reserved.
							O	EMC_CS1 — LOW active Chip Select 1 signal.
							-	R — Function reserved.
							I	T2_CAP2 — Capture input 2 of timer 2.
							-	R — Function reserved.
P6_4	R16	M14	F6	80	[2]	N; PU	I/O	GPIO3[3] — General purpose digital input/output pin.
							I	CTIN_6 — SCT input 6. Capture input 1 of timer 3.
							O	U0_TXD — Transmitter output for USART0.
							O	EMC_CAS — LOW active SDRAM Column Address Strobe.
							-	R — Function reserved.
							-	R — Function reserved.
							-	R — Function reserved.

Table 169. LPC1850/30/20/10 Pin description (flashless parts) ...continued
 LCD, Ethernet, USB0, and USB1 functions are not available on all parts.

Symbol	LBGA256	TFBGA180	TFBGA100	LQFP144		Reset state [1]	Type	Description
P6_5	P16	L14	F9	82	[2]	N; PU	I/O	GPIO3[4] — General purpose digital input/output pin.
							O	CTOUT_6 — SCT output 6. Match output 2 of timer 1.
							I	U0_RXD — Receiver input for USART0.
							O	EMC_RAS — LOW active SDRAM Row Address Strobe.
							-	R — Function reserved.
							-	R — Function reserved.
P6_6	L14	K12	-	83	[2]	N; PU	I/O	GPIO0[5] — General purpose digital input/output pin.
							O	EMC_BLS1 — LOW active Byte Lane select signal 1.
							-	R — Function reserved.
							I	USB0_PWR_FAULT — Port power fault signal indicating overcurrent condition; this signal monitors over-current on the USB bus (external circuitry required to detect over-current condition).
							-	R — Function reserved.
							-	R — Function reserved.
P6_7	J13	H11	-	85	[2]	N; PU	-	R — Function reserved.
							I/O	EMC_A15 — External memory address line 15.
							-	R — Function reserved.
							O	USB0_IND1 — USB0 port indicator LED control output 1.
							I/O	GPIO5[15] — General purpose digital input/output pin.
							O	T2_MAT0 — Match output 0 of timer 2.
-	R — Function reserved.							
-	R — Function reserved.							
P6_8	H13	F12	-	86	[2]	N; PU	-	R — Function reserved.
							I/O	EMC_A14 — External memory address line 14.
							-	R — Function reserved.
							O	USB0_IND0 — USB0 port indicator LED control output 0.
							I/O	GPIO5[16] — General purpose digital input/output pin.
							O	T2_MAT1 — Match output 1 of timer 2.
-	R — Function reserved.							
-	R — Function reserved.							

Table 169. LPC1850/30/20/10 Pin description (flashless parts) ...continued
 LCD, Ethernet, USB0, and USB1 functions are not available on all parts.

Symbol	LBGA256	TFBGA180	TFBGA100	LQFP144		Reset state [1]	Type	Description
P6_9	J15	H13	F8	97	[2]	N; PU	I/O	GPIO3[5] — General purpose digital input/output pin.
								- R — Function reserved.
								- R — Function reserved.
								O EMC_DYCS0 — SDRAM chip select 0.
								- R — Function reserved.
								O T2_MAT2 — Match output 2 of timer 2.
								- R — Function reserved.
- R — Function reserved.								
P6_10	H15	G13	-	100	[2]	N; PU	I/O	GPIO3[6] — General purpose digital input/output pin.
								O MCABORT — Motor control PWM, LOW-active fast abort.
								- R — Function reserved.
								O EMC_DQMOUT1 — Data mask 1 used with SDRAM and static devices.
								- R — Function reserved.
								- R — Function reserved.
								- R — Function reserved.
- R — Function reserved.								
P6_11	H12	F11	C9	101	[2]	N; PU	I/O	GPIO3[7] — General purpose digital input/output pin.
								- R — Function reserved.
								- R — Function reserved.
								O EMC_CKEOUT0 — SDRAM clock enable 0.
								- R — Function reserved.
								O T2_MAT3 — Match output 3 of timer 2.
								- R — Function reserved.
- R — Function reserved.								
P6_12	G15	F13	-	103	[2]	N; PU	I/O	GPIO2[8] — General purpose digital input/output pin.
								O CTOUT_7 — SCT output 7. Match output 3 of timer 1.
								- R — Function reserved.
								O EMC_DQMOUT0 — Data mask 0 used with SDRAM and static devices.
								- R — Function reserved.
								- R — Function reserved.
								- R — Function reserved.
- R — Function reserved.								

Table 169. LPC1850/30/20/10 Pin description (flashless parts) ...continued
 LCD, Ethernet, USB0, and USB1 functions are not available on all parts.

Symbol	LBGA256	TFBGA180	TFBGA100	LQFP144		Reset state [1]	Type	Description
P7_0	B16	B14	-	110	[2]	N; PU	I/O	GPIO3[8] — General purpose digital input/output pin.
							O	CTOUT_14 — SCT output 14. Match output 2 of timer 3.
							-	R — Function reserved.
							O	LCD_LE — Line end signal.
							-	R — Function reserved.
							-	R — Function reserved.
							-	R — Function reserved.
P7_1	C14	C13	-	113	[2]	N; PU	I/O	GPIO3[9] — General purpose digital input/output pin.
							O	CTOUT_15 — SCT output 15. Match output 3 of timer 3.
							I/O	I2S0_TX_WS — Transmit Word Select. It is driven by the master and received by the slave. Corresponds to the signal WS in the <i>I²S-bus specification</i> .
							O	LCD_VD19 — LCD data.
							O	LCD_VD7 — LCD data.
							-	R — Function reserved.
							O	U2_TXD — Transmitter output for USART2.
P7_2	A16	A14	-	115	[2]	N; PU	I/O	GPIO3[10] — General purpose digital input/output pin.
							I	CTIN_4 — SCT input 4. Capture input 2 of timer 1.
							I/O	I2S0_TX_SDA — I ² S transmit data. It is driven by the transmitter and read by the receiver. Corresponds to the signal SD in the <i>I²S-bus specification</i> .
							O	LCD_VD18 — LCD data.
							O	LCD_VD6 — LCD data.
							-	R — Function reserved.
							I	U2_RXD — Receiver input for USART2.
P7_3	C13	C12	-	117	[2]	N; PU	I/O	GPIO3[11] — General purpose digital input/output pin.
							I	CTIN_3 — SCT input 3. Capture input 1 of timer 1.
							-	R — Function reserved.
							O	LCD_VD17 — LCD data.
							O	LCD_VD5 — LCD data.
							-	R — Function reserved.
							-	R — Function reserved.
-	R — Function reserved.							

Table 169. LPC1850/30/20/10 Pin description (flashless parts) ...continued
 LCD, Ethernet, USB0, and USB1 functions are not available on all parts.

Symbol	LBGA256	TFBGA180	TFBGA100	LQFP144		Reset state [1]	Type	Description
P7_4	C8	C6	-	132	[5]	N; PU	I/O	GPIO3[12] — General purpose digital input/output pin.
							O	CTOUT_13 — SCT output 13. Match output 3 of timer 3.
							-	R — Function reserved.
							O	LCD_VD16 — LCD data.
							O	LCD_VD4 — LCD data.
							O	TRACEDATA[0] — Trace data, bit 0.
							-	R — Function reserved.
							-	R — Function reserved.
AI	ADC0_4 — ADC0 and ADC1, input channel 4. Configure the pin as GPIO input and use the ADC function select register in the SCU to select the ADC.							
P7_5	A7	A7	-	133	[5]	N; PU	I/O	GPIO3[13] — General purpose digital input/output pin.
							O	CTOUT_12 — SCT output 12. Match output 3 of timer 3.
							-	R — Function reserved.
							O	LCD_VD8 — LCD data.
							O	LCD_VD23 — LCD data.
							O	TRACEDATA[1] — Trace data, bit 1.
							-	R — Function reserved.
							-	R — Function reserved.
AI	ADC0_3 — ADC0 and ADC1, input channel 3. Configure the pin as GPIO input and use the ADC function select register in the SCU to select the ADC.							
P7_6	C7	F5	-	134	[2]	N; PU	I/O	GPIO3[14] — General purpose digital input/output pin.
							O	CTOUT_11 — SCT output 1. Match output 3 of timer 2.
							-	R — Function reserved.
							O	LCD_LP — Line synchronization pulse (STN). Horizontal synchronization pulse (TFT).
							-	R — Function reserved.
							O	TRACEDATA[2] — Trace data, bit 2.
							-	R — Function reserved.
							-	R — Function reserved.

Table 169. LPC1850/30/20/10 Pin description (flashless parts) ...continued
 LCD, Ethernet, USB0, and USB1 functions are not available on all parts.

Symbol	LBGA256	TFBGA180	TFBGA100	LQFP144	Reset state	Type	Description	
P7_7	B6	D5	-	140	[5]	N; PU	I/O	GPIO3[15] — General purpose digital input/output pin.
							O	CTOUT_8 — SCT output 8. Match output 0 of timer 2.
							-	R — Function reserved.
							O	LCD_PWR — LCD panel power enable.
							-	R — Function reserved.
							O	TRACEDATA[3] — Trace data, bit 3.
							O	ENET_MDC — Ethernet MIIM clock.
							-	R — Function reserved.
P8_0	E5	E4	-	-	[3]	N; PU	I/O	GPIO4[0] — General purpose digital input/output pin.
							I	USB0_PWR_FAULT — Port power fault signal indicating overcurrent condition; this signal monitors over-current on the USB bus (external circuitry required to detect over-current condition).
							-	R — Function reserved.
							I	MC12 — Motor control PWM channel 2, input.
							-	R — Function reserved.
							-	R — Function reserved.
							-	R — Function reserved.
							O	T0_MAT0 — Match output 0 of timer 0.
P8_1	H5	G4	-	-	[3]	N; PU	I/O	GPIO4[1] — General purpose digital input/output pin.
							O	USB0_IND1 — USB0 port indicator LED control output 1.
							-	R — Function reserved.
							I	MC11 — Motor control PWM channel 1, input.
							-	R — Function reserved.
							-	R — Function reserved.
							-	R — Function reserved.
							O	T0_MAT1 — Match output 1 of timer 0.
P8_2	K4	J4	-	-	[3]	N; PU	I/O	GPIO4[2] — General purpose digital input/output pin.
							O	USB0_IND0 — USB0 port indicator LED control output 0.
							-	R — Function reserved.
							I	MC10 — Motor control PWM channel 0, input.
							-	R — Function reserved.
							-	R — Function reserved.
							-	R — Function reserved.
							O	T0_MAT2 — Match output 2 of timer 0.

Table 169. LPC1850/30/20/10 Pin description (flashless parts) ...continued
 LCD, Ethernet, USB0, and USB1 functions are not available on all parts.

Symbol	LBGA256	TFBGA180	TFBGA100	LQFP144	Reset state [1]	Type	Description
P8_3	J3	H3	-	-	[2]	N; PU	I/O GPIO4[3] — General purpose digital input/output pin.
							I/O USB1_ULPI_D2 — ULPI link bidirectional data line 2.
							- R — Function reserved.
							O LCD_VD12 — LCD data.
							O LCD_VD19 — LCD data.
							- R — Function reserved.
							- R — Function reserved.
O T0_MAT3 — Match output 3 of timer 0.							
P8_4	J2	H2	-	-	[2]	N; PU	I/O GPIO4[4] — General purpose digital input/output pin.
							I/O USB1_ULPI_D1 — ULPI link bidirectional data line 1.
							- R — Function reserved.
							O LCD_VD7 — LCD data.
							O LCD_VD16 — LCD data.
							- R — Function reserved.
							- R — Function reserved.
I T0_CAP0 — Capture input 0 of timer 0.							
P8_5	J1	H1	-	-	[2]	N; PU	I/O GPIO4[5] — General purpose digital input/output pin.
							I/O USB1_ULPI_D0 — ULPI link bidirectional data line 0.
							- R — Function reserved.
							O LCD_VD6 — LCD data.
							O LCD_VD8 — LCD data.
							- R — Function reserved.
							- R — Function reserved.
I T0_CAP1 — Capture input 1 of timer 0.							
P8_6	K3	J3	-	-	[2]	N; PU	I/O GPIO4[6] — General purpose digital input/output pin.
							I USB1_ULPI_NXT — ULPI link NXT signal. Data flow control signal from the PHY.
							- R — Function reserved.
							O LCD_VD5 — LCD data.
							O LCD_LP — Line synchronization pulse (STN). Horizontal synchronization pulse (TFT).
							- R — Function reserved.
							- R — Function reserved.
I T0_CAP2 — Capture input 2 of timer 0.							

Table 169. LPC1850/30/20/10 Pin description (flashless parts) ...continued
 LCD, Ethernet, USB0, and USB1 functions are not available on all parts.

Symbol	LBGA256	TFBGA180	TFBGA100	LQFP144	Reset state [1]	Type	Description	
P8_7	K1	J1	-	-	[2]	N; PU	I/O	GPIO4[7] — General purpose digital input/output pin.
							O	USB1_ULPI_STP — ULPI link STP signal. Asserted to end or interrupt transfers to the PHY.
							-	R — Function reserved.
							O	LCD_VD4 — LCD data.
							O	LCD_PWR — LCD panel power enable.
							-	R — Function reserved.
							-	R — Function reserved.
P8_8	L1	K1	-	-	[2]	N; PU	-	R — Function reserved.
							I	USB1_ULPI_CLK — ULPI link CLK signal. 60 MHz clock generated by the PHY.
							-	R — Function reserved.
							-	R — Function reserved.
							-	R — Function reserved.
							-	R — Function reserved.
							O	CGU_OUT0 — CGU spare clock output 0.
O	I2S1_TX_MCLK — I ² S1 transmit master clock.							
P9_0	T1	P1	-	-	[2]	N; PU	I/O	GPIO4[12] — General purpose digital input/output pin.
							O	MCABORT — Motor control PWM, LOW-active fast abort.
							-	R — Function reserved.
							-	R — Function reserved.
							-	R — Function reserved.
							I	ENET_CRS — Ethernet Carrier Sense (MII interface).
							-	R — Function reserved.
I/O	SSP0_SSEL — Slave Select for SSP0.							
P9_1	N6	P4	-	-	[2]	N; PU	I/O	GPIO4[13] — General purpose digital input/output pin.
							O	MCOA2 — Motor control PWM channel 2, output A.
							-	R — Function reserved.
							-	R — Function reserved.
							I/O	I2S0_TX_WS — Transmit Word Select. It is driven by the master and received by the slave. Corresponds to the signal WS in the <i>I²S-bus specification</i> .
							I	ENET_RX_ER — Ethernet receive error (MII interface).
							-	R — Function reserved.
I/O	SSP0_MISO — Master In Slave Out for SSP0.							

Table 169. LPC1850/30/20/10 Pin description (flashless parts) ...continued
 LCD, Ethernet, USB0, and USB1 functions are not available on all parts.

Symbol	LBGA256	TFBGA180	TFBGA100	LQFP144	Reset state	Type	Description
P9_2	N8	M6	-	-	[2] N; PU	I/O	GPIO4[14] — General purpose digital input/output pin.
							O MCOB2 — Motor control PWM channel 2, output B.
							- R — Function reserved.
							- R — Function reserved.
							I/O I2S0_TX_SDA — I ² S transmit data. It is driven by the transmitter and read by the receiver. Corresponds to the signal SD in the <i>I²S-bus specification</i> .
							I ENET_RXD3 — Ethernet receive data 3 (MII interface).
							- R — Function reserved.
I/O SSP0_MOSI — Master Out Slave in for SSP0.							
P9_3	M6	P5	-	-	[2] N; PU	I/O	GPIO4[15] — General purpose digital input/output pin.
							O MCOA0 — Motor control PWM channel 0, output A.
							O USB1_IND1 — USB1 Port indicator LED control output 1.
							- R — Function reserved.
							- R — Function reserved.
							I ENET_RXD2 — Ethernet receive data 2 (MII interface).
							- R — Function reserved.
O U3_TXD — Transmitter output for USART3.							
P9_4	N10	M8	-	-	[2] N; PU	-	R — Function reserved.
							O MCOB0 — Motor control PWM channel 0, output B.
							O USB1_IND0 — USB1 Port indicator LED control output 0.
							- R — Function reserved.
							I/O GPIO5[17] — General purpose digital input/output pin.
							O ENET_TXD2 — Ethernet transmit data 2 (MII interface).
							- R — Function reserved.
I U3_RXD — Receiver input for USART3.							
P9_5	M9	L7	-	69	[2] N; PU	-	R — Function reserved.
							O MCOA1 — Motor control PWM channel 1, output A.
							O USB1_PPWR — VBUS drive signal (towards external charge pump or power management unit); indicates that VBUS must be driven (active HIGH). Add a pull-down resistor to disable the power switch at reset. This signal has opposite polarity compared to the USB_PPWR used on other NXP LPC parts.
							- R — Function reserved.
							I/O GPIO5[18] — General purpose digital input/output pin.
							O ENET_TXD3 — Ethernet transmit data 3 (MII interface).
							- R — Function reserved.
							O U0_TXD — Transmitter output for USART0.

Table 169. LPC1850/30/20/10 Pin description (flashless parts) ...continued
 LCD, Ethernet, USB0, and USB1 functions are not available on all parts.

Symbol	LBGA256	TFBGA180	TFBGA100	LQFP144		Reset state [1]	Type	Description
P9_6	L11	M9	-	72	[2]	N; PU	I/O	GPIO4[11] — General purpose digital input/output pin.
							O	MCOB1 — Motor control PWM channel 1, output B.
							I	USB1_PWR_FAULT — USB1 Port power fault signal indicating over-current condition; this signal monitors over-current on the USB1 bus (external circuitry required to detect over-current condition).
							-	R — Function reserved.
							-	R — Function reserved.
							I	ENET_COL — Ethernet Collision detect (MII interface).
							-	R — Function reserved.
							I	U0_RXD — Receiver input for USART0.
PA_0	L12	L10	-	-	[2]	N; PU	-	R — Function reserved.
							-	R — Function reserved.
							-	R — Function reserved.
							-	R — Function reserved.
							-	R — Function reserved.
							O	I2S1_RX_MCLK — I ² S1 receive master clock.
							O	CGU_OUT1 — CGU spare clock output 1.
							-	R — Function reserved.
PA_1	J14	H12	-	-	[3]	N; PU	I/O	GPIO4[8] — General purpose digital input/output pin.
							I	QEI_IDX — Quadrature Encoder Interface INDEX input.
							-	R — Function reserved.
							O	U2_TXD — Transmitter output for USART2.
							-	R — Function reserved.
							-	R — Function reserved.
							-	R — Function reserved.
							-	R — Function reserved.
PA_2	K15	J13	-	-	[3]	N; PU	I/O	GPIO4[9] — General purpose digital input/output pin.
							I	QEI_PHB — Quadrature Encoder Interface PHB input.
							-	R — Function reserved.
							I	U2_RXD — Receiver input for USART2.
							-	R — Function reserved.
							-	R — Function reserved.
							-	R — Function reserved.
							-	R — Function reserved.

Table 169. LPC1850/30/20/10 Pin description (flashless parts) ...continued
 LCD, Ethernet, USB0, and USB1 functions are not available on all parts.

Symbol	LBGA256	TFBGA180	TFBGA100	LQFP144	Reset state [1]	Type	Description
PA_3	H11	E10	-	-	[3]	N; PU	I/O GPIO4[10] — General purpose digital input/output pin.
							I QEI_PHA — Quadrature Encoder Interface PHA input.
							- R — Function reserved.
							- R — Function reserved.
							- R — Function reserved.
							- R — Function reserved.
							- R — Function reserved.
							- R — Function reserved.
PA_4	G13	E12	-	-	[2]	N; PU	- R — Function reserved.
							O CTOUT_9 — SCT output 9. Match output 3 of timer 3.
							- R — Function reserved.
							I/O EMC_A23 — External memory address line 23.
							I/O GPIO5[19] — General purpose digital input/output pin.
							- R — Function reserved.
							- R — Function reserved.
							- R — Function reserved.
PB_0	B15	D14	-	-	[2]	N; PU	- R — Function reserved.
							O CTOUT_10 — SCT output 10. Match output 3 of timer 3.
							O LCD_VD23 — LCD data.
							- R — Function reserved.
							I/O GPIO5[20] — General purpose digital input/output pin.
							- R — Function reserved.
							- R — Function reserved.
							- R — Function reserved.
PB_1	A14	A13	-	-	[2]	N; PU	- R — Function reserved.
							I USB1_ULPI_DIR — ULPI link DIR signal. Controls the ULP data line direction.
							O LCD_VD22 — LCD data.
							- R — Function reserved.
							I/O GPIO5[21] — General purpose digital input/output pin.
							O CTOUT_6 — SCT output 6. Match output 2 of timer 1.
							- R — Function reserved.
							- R — Function reserved.

Table 169. LPC1850/30/20/10 Pin description (flashless parts) ...continued
 LCD, Ethernet, USB0, and USB1 functions are not available on all parts.

Symbol	LBGA256	TFBGA180	TFBGA100	LQFP144	Reset state [2]	Type [1]	Description
PB_2	B12	B11	-	-	[2]	N; PU	- R — Function reserved.
							I/O USB1_ULPI_D7 — ULPI link bidirectional data line 7.
							O LCD_VD21 — LCD data.
							- R — Function reserved.
							I/O GPIO5[22] — General purpose digital input/output pin.
							O CTOUT_7 — SCT output 7. Match output 3 of timer 1.
PB_3	A13	A12	-	-	[2]	N; PU	- R — Function reserved.
							I/O USB1_ULPI_D6 — ULPI link bidirectional data line 6.
							O LCD_VD20 — LCD data.
							- R — Function reserved.
							I/O GPIO5[23] — General purpose digital input/output pin.
							O CTOUT_8 — SCT output 8. Match output 0 of timer 2.
PB_4	B11	B10	-	-	[2]	N; PU	- R — Function reserved.
							I/O USB1_ULPI_D5 — ULPI link bidirectional data line 5.
							O LCD_VD15 — LCD data.
							- R — Function reserved.
							I/O GPIO5[24] — General purpose digital input/output pin.
							I CTIN_5 — SCT input 5. Capture input 2 of timer 2.
PB_5	A12	A11	-	-	[2]	N; PU	- R — Function reserved.
							I/O USB1_ULPI_D4 — ULPI link bidirectional data line 4.
							O LCD_VD14 — LCD data.
							- R — Function reserved.
							I/O GPIO5[25] — General purpose digital input/output pin.
							I CTIN_7 — SCT input 7.
O LCD_PWR — LCD panel power enable.							
- R — Function reserved.							

Table 169. LPC1850/30/20/10 Pin description (flashless parts) ...continued
 LCD, Ethernet, USB0, and USB1 functions are not available on all parts.

Symbol	LBGA256	TFBGA180	TFBGA100	LQFP144	Reset state	Type	Description
PB_6	A6	C5	-	-	[5]	N; PU	- R — Function reserved.
							I/O USB1_ULPI_D3 — ULPI link bidirectional data line 3.
							O LCD_VD13 — LCD data.
							- R — Function reserved.
							I/O GPIO5[26] — General purpose digital input/output pin.
							I CTIN_6 — SCT input 6. Capture input 1 of timer 3.
							O LCD_VD19 — LCD data.
							- R — Function reserved.
PC_0	D4	-	-	-	[5]	N; PU	- R — Function reserved.
							I USB1_ULPI_CLK — ULPI link CLK signal. 60 MHz clock generated by the PHY.
							- R — Function reserved.
							I/O ENET_RX_CLK — Ethernet Receive Clock (MII interface).
							O LCD_DCLK — LCD panel clock.
							- R — Function reserved.
							- R — Function reserved.
							I/O SD_CLK — SD/MMC card clock.
AI ADC1_1 — ADC1 and ADC0, input channel 1. Configure the pin as USB1_ULPI_CLK input and use the ADC function select register in the SCU to select the ADC.							
PC_1	E4	-	-	-	[2]	N; PU	I/O USB1_ULPI_D7 — ULPI link bidirectional data line 7.
							- R — Function reserved.
							I U1_RI — Ring Indicator input for UART1.
							O ENET_MDC — Ethernet MIIM clock.
							I/O GPIO6[0] — General purpose digital input/output pin.
							- R — Function reserved.
							I T3_CAP0 — Capture input 0 of timer 3.
							O SD_VOLT0 — SD/MMC bus voltage select output 0.
PC_2	F6	-	-	-	[2]	N; PU	I/O USB1_ULPI_D6 — ULPI link bidirectional data line 6.
							- R — Function reserved.
							I U1_CTS — Clear to Send input for UART1.
							O ENET_TXD2 — Ethernet transmit data 2 (MII interface).
							I/O GPIO6[1] — General purpose digital input/output pin.
							- R — Function reserved.
							- R — Function reserved.
							O SD_RST — SD/MMC reset signal for MMC4.4 card.

Table 169. LPC1850/30/20/10 Pin description (flashless parts) ...continued
 LCD, Ethernet, USB0, and USB1 functions are not available on all parts.

Symbol	LBGA256	TFBGA180	TFBGA100	LQFP144	Reset state [1]	Type	Description
PC_3	F5	-	-	-	[5]	N; PU	I/O USB1_ULPI_D5 — ULPI link bidirectional data line 5.
							- R — Function reserved.
							O U1_RTS — Request to Send output for UART1. Can also be configured to be an RS-485/EIA-485 output enable signal for UART1.
							O ENET_TXD3 — Ethernet transmit data 3 (MII interface).
							I/O GPIO6[2] — General purpose digital input/output pin.
							- R — Function reserved.
							- R — Function reserved.
O SD_VOLT1 — SD/MMC bus voltage select output 1.							
AI ADC1_0 — DAC out, ADC1 and ADC0, input channel 0. Configure the pin as GPIO input and use the ADC function select register in the SCU to select the ADC.							
PC_4	F4	-	-	-	[2]	N; PU	- R — Function reserved.
							I/O USB1_ULPI_D4 — ULPI link bidirectional data line 4.
							- R — Function reserved.
							ENET_TX_EN — Ethernet transmit enable (RMII/MII interface).
							I/O GPIO6[3] — General purpose digital input/output pin.
							- R — Function reserved.
							I T3_CAP1 — Capture input 1 of timer 3.
I/O SD_DAT0 — SD/MMC data bus line 0.							
PC_5	G4	-	-	-	[2]	N; PU	- R — Function reserved.
							I/O USB1_ULPI_D3 — ULPI link bidirectional data line 3.
							- R — Function reserved.
							O ENET_TX_ER — Ethernet Transmit Error (MII interface).
							I/O GPIO6[4] — General purpose digital input/output pin.
							- R — Function reserved.
							I T3_CAP2 — Capture input 2 of timer 3.
I/O SD_DAT1 — SD/MMC data bus line 1.							
PC_6	H6	-	-	-	[2]	N; PU	- R — Function reserved.
							I/O USB1_ULPI_D2 — ULPI link bidirectional data line 2.
							- R — Function reserved.
							I ENET_RXD2 — Ethernet receive data 2 (MII interface).
							I/O GPIO6[5] — General purpose digital input/output pin.
							- R — Function reserved.
							I T3_CAP3 — Capture input 3 of timer 3.
I/O SD_DAT2 — SD/MMC data bus line 2.							

Table 169. LPC1850/30/20/10 Pin description (flashless parts) ...continued
 LCD, Ethernet, USB0, and USB1 functions are not available on all parts.

Symbol	LBGA256	TFBGA180	TFBGA100	LQFP144	Reset state	Type	Description
PC_7	G5	-	-	-	[2] N; PU	-	R — Function reserved.
						I/O	USB1_ULPI_D1 — ULPI link bidirectional data line 1.
						-	R — Function reserved.
						I	ENET_RXD3 — Ethernet receive data 3 (MII interface).
						I/O	GPIO6[6] — General purpose digital input/output pin.
						-	R — Function reserved.
						O	T3_MAT0 — Match output 0 of timer 3.
PC_8	N4	-	-	-	[2] N; PU	-	R — Function reserved.
						I/O	USB1_ULPI_D0 — ULPI link bidirectional data line 0.
						-	R — Function reserved.
						I	ENET_RX_DV — Ethernet Receive Data Valid (RMII/MII interface).
						I/O	GPIO6[7] — General purpose digital input/output pin.
						-	R — Function reserved.
						O	T3_MAT1 — Match output 1 of timer 3.
PC_9	K2	-	-	-	[2] N; PU	-	R — Function reserved.
						I	USB1_ULPI_NXT — ULPI link NXT signal. Data flow control signal from the PHY.
						-	R — Function reserved.
						I	ENET_RX_ER — Ethernet receive error (MII interface).
						I/O	GPIO6[8] — General purpose digital input/output pin.
						-	R — Function reserved.
						O	T3_MAT2 — Match output 2 of timer 3.
PC_10	M5	-	-	-	[2] N; PU	-	R — Function reserved.
						O	USB1_ULPI_STP — ULPI link STP signal. Asserted to end or interrupt transfers to the PHY.
						I	U1_DSR — Data Set Ready input for UART1.
						-	R — Function reserved.
						I/O	GPIO6[9] — General purpose digital input/output pin.
						-	R — Function reserved.
						O	T3_MAT3 — Match output 3 of timer 3.
I/O	SD_CMD — SD/MMC command signal.						

Table 169. LPC1850/30/20/10 Pin description (flashless parts) ...continued
 LCD, Ethernet, USB0, and USB1 functions are not available on all parts.

Symbol	LBGA256	TFBGA180	TFBGA100	LQFP144	Reset state	Type	Description
PC_11	L5	-	-	-	[2] N; PU	-	R — Function reserved.
						I	USB1_ULPI_DIR — ULPI link DIR signal. Controls the ULP data line direction.
						I	U1_DCD — Data Carrier Detect input for UART1.
						-	R — Function reserved.
						I/O	GPIO6[10] — General purpose digital input/output pin.
						-	R — Function reserved.
						-	R — Function reserved.
PC_12	L6	-	-	-	[2] N; PU	-	R — Function reserved.
						-	R — Function reserved.
						O	U1_DTR — Data Terminal Ready output for UART1. Can also be configured to be an RS-485/EIA-485 output enable signal for UART1.
						-	R — Function reserved.
						I/O	GPIO6[11] — General purpose digital input/output pin.
						-	R — Function reserved.
						I/O	I2S0_TX_SDA — I ² S transmit data. It is driven by the transmitter and read by the receiver. Corresponds to the signal SD in the <i>PS-bus specification</i> .
PC_13	M1	-	-	-	[2] N; PU	-	R — Function reserved.
						-	R — Function reserved.
						O	U1_TXD — Transmitter output for UART1.
						-	R — Function reserved.
						I/O	GPIO6[12] — General purpose digital input/output pin.
						-	R — Function reserved.
						I/O	I2S0_TX_WS — Transmit Word Select. It is driven by the master and received by the slave. Corresponds to the signal WS in the <i>PS-bus specification</i> .
PC_14	N1	-	-	-	[2] N; PU	-	R — Function reserved.
						-	R — Function reserved.
						I	U1_RXD — Receiver input for UART1.
						-	R — Function reserved.
						I/O	GPIO6[13] — General purpose digital input/output pin.
						-	R — Function reserved.
						O	ENET_TX_ER — Ethernet Transmit Error (MII interface).
I/O	SD_DAT7 — SD/MMC data bus line 7.						

Table 169. LPC1850/30/20/10 Pin description (flashless parts) ...continued
LCD, Ethernet, USB0, and USB1 functions are not available on all parts.

Symbol	LBGA256	TFBGA180	TFBGA100	LQFP144	Reset state [1]	Type	Description
PD_0	N2	-	-	-	[2]	N; PU	- R — Function reserved.
							O CTOUT_15 — SCT output 15. Match output 3 of timer 3.
							O EMC_DQMOUT2 — Data mask 2 used with SDRAM and static devices.
							- R — Function reserved.
							I/O GPIO6[14] — General purpose digital input/output pin.
							- R — Function reserved.
							- R — Function reserved.
PD_1	P1	-	-	-	[2]	N; PU	- R — Function reserved.
							- R — Function reserved.
							O EMC_CKEOUT2 — SDRAM clock enable 2.
							- R — Function reserved.
							I/O GPIO6[15] — General purpose digital input/output pin.
							O SD_POW — SD/MMC power monitor output.
							- R — Function reserved.
PD_2	R1	-	-	-	[2]	N; PU	- R — Function reserved.
							O CTOUT_7 — SCT output 7. Match output 3 of timer 1.
							I/O EMC_D16 — External memory data line 16.
							- R — Function reserved.
							I/O GPIO6[16] — General purpose digital input/output pin.
							- R — Function reserved.
							- R — Function reserved.
PD_3	P4	-	-	-	[2]	N; PU	- R — Function reserved.
							O CTOUT_6 — SCT output 6. Match output 2 of timer 1.
							I/O EMC_D17 — External memory data line 17.
							- R — Function reserved.
							I/O GPIO6[17] — General purpose digital input/output pin.
							- R — Function reserved.
							- R — Function reserved.

Table 169. LPC1850/30/20/10 Pin description (flashless parts) ...continued
LCD, Ethernet, USB0, and USB1 functions are not available on all parts.

Symbol	LBGA256	TFBGA180	TFBGA100	LQFP144	Reset state [2]	Type [1]	Description
PD_4	T2	-	-	-	[2]	N; PU	- R — Function reserved.
							O CTOUT_8 — SCT output 8. Match output 0 of timer 2.
							I/O EMC_D18 — External memory data line 18.
							- R — Function reserved.
							I/O GPIO6[18] — General purpose digital input/output pin.
							- R — Function reserved.
PD_5	P6	-	-	-	[2]	N; PU	- R — Function reserved.
							O CTOUT_9 — SCT output 9. Match output 3 of timer 3.
							I/O EMC_D19 — External memory data line 19.
							- R — Function reserved.
							I/O GPIO6[19] — General purpose digital input/output pin.
							- R — Function reserved.
PD_6	R6	-	-	-	[2]	N; PU	- R — Function reserved.
							O CTOUT_10 — SCT output 10. Match output 3 of timer 3.
							I/O EMC_D20 — External memory data line 20.
							- R — Function reserved.
							I/O GPIO6[20] — General purpose digital input/output pin.
							- R — Function reserved.
PD_7	T6	-	-	-	[2]	N; PU	- R — Function reserved.
							I CTIN_5 — SCT input 5. Capture input 2 of timer 2.
							I/O EMC_D21 — External memory data line 21.
							- R — Function reserved.
							I/O GPIO6[21] — General purpose digital input/output pin.
							- R — Function reserved.

Table 169. LPC1850/30/20/10 Pin description (flashless parts) ...continued
 LCD, Ethernet, USB0, and USB1 functions are not available on all parts.

Symbol	LBGA256	TFBGA180	TFBGA100	LQFP144	Reset state [2]	Type [1]	Description
PD_8	P8	-	-	-	[2]	N; PU	- R — Function reserved.
							I CTIN_6 — SCT input 6. Capture input 1 of timer 3.
							I/O EMC_D22 — External memory data line 22.
							- R — Function reserved.
							I/O GPIO6[22] — General purpose digital input/output pin.
							- R — Function reserved.
							- R — Function reserved.
PD_9	T11	-	-	-	[2]	N; PU	- R — Function reserved.
							O CTOUT_13 — SCT output 13. Match output 3 of timer 3.
							I/O EMC_D23 — External memory data line 23.
							- R — Function reserved.
							I/O GPIO6[23] — General purpose digital input/output pin.
							- R — Function reserved.
							- R — Function reserved.
PD_10	P11	-	-	-	[2]	N; PU	- R — Function reserved.
							I CTIN_1 — SCT input 1. Capture input 1 of timer 0. Capture input 1 of timer 2.
							O EMC_BLS3 — LOW active Byte Lane select signal 3.
							- R — Function reserved.
							I/O GPIO6[24] — General purpose digital input/output pin.
							- R — Function reserved.
							- R — Function reserved.
PD_11	N9	M7	-	-	[2]	N; PU	- R — Function reserved.
							- R — Function reserved.
							O EMC_CS3 — LOW active Chip Select 3 signal.
							- R — Function reserved.
							I/O GPIO6[25] — General purpose digital input/output pin.
							I/O USB1_ULPI_D0 — ULPI link bidirectional data line 0.
							O CTOUT_14 — SCT output 14. Match output 2 of timer 3.
- R — Function reserved.							

Table 169. LPC1850/30/20/10 Pin description (flashless parts) ...continued
 LCD, Ethernet, USB0, and USB1 functions are not available on all parts.

Symbol	LPGA256	TFBGA180	TFBGA100	LQFP144	Reset state [1]	Type	Description
PD_12	N11	P9	-	-	[2]	N; PU	- R — Function reserved.
							- R — Function reserved.
							O EMC_CS2 — LOW active Chip Select 2 signal.
							- R — Function reserved.
							I/O GPIO6[26] — General purpose digital input/output pin.
							- R — Function reserved.
							O CTOUT_10 — SCT output 10. Match output 3 of timer 3.
PD_13	T14	-	-	-	[2]	N; PU	- R — Function reserved.
							I CTIN_0 — SCT input 0. Capture input 0 of timer 0, 1, 2, 3.
							O EMC_BLS2 — LOW active Byte Lane select signal 2.
							- R — Function reserved.
							I/O GPIO6[27] — General purpose digital input/output pin.
							- R — Function reserved.
							O CTOUT_13 — SCT output 13. Match output 3 of timer 3.
PD_14	R13	L11	-	-	[2]	N; PU	- R — Function reserved.
							- R — Function reserved.
							O EMC_DYCS2 — SDRAM chip select 2.
							- R — Function reserved.
							I/O GPIO6[28] — General purpose digital input/output pin.
							- R — Function reserved.
							O CTOUT_11 — SCT output 11. Match output 3 of timer 2.
PD_15	T15	P13	-	-	[2]	N; PU	- R — Function reserved.
							- R — Function reserved.
							I/O EMC_A17 — External memory address line 17.
							- R — Function reserved.
							I/O GPIO6[29] — General purpose digital input/output pin.
							I SD_WP — SD/MMC card write protect input.
							O CTOUT_8 — SCT output 8. Match output 0 of timer 2.
- R — Function reserved.							

Table 169. LPC1850/30/20/10 Pin description (flashless parts) ...continued
LCD, Ethernet, USB0, and USB1 functions are not available on all parts.

Symbol	LPGA256	TFBGA180	TFBGA100	LQFP144	Reset state [1]	Type	Description
PD_16	R14	P12	-	-	[2]	N; PU	- R — Function reserved.
							- R — Function reserved.
							I/O EMC_A16 — External memory address line 16.
							- R — Function reserved.
							I/O GPIO6[30] — General purpose digital input/output pin.
							O SD_VOLT2 — SD/MMC bus voltage select output 2.
							O CTOUT_12 — SCT output 12. Match output 3 of timer 3.
PE_0	P14	N12	-	-	[2]	N; PU	- R — Function reserved.
							- R — Function reserved.
							- R — Function reserved.
							I/O EMC_A18 — External memory address line 18.
							I/O GPIO7[0] — General purpose digital input/output pin.
							O CAN1_TD — CAN1 transmitter output.
							- R — Function reserved.
PE_1	N14	M12	-	-	[2]	N; PU	- R — Function reserved.
							- R — Function reserved.
							- R — Function reserved.
							I/O EMC_A19 — External memory address line 19.
							I/O GPIO7[1] — General purpose digital input/output pin.
							I CAN1_RD — CAN1 receiver input.
							- R — Function reserved.
PE_2	M14	L12	-	-	[2]	N; PU	I ADCTRIG0 — ADC trigger input 0.
							I CAN0_RD — CAN receiver input.
							- R — Function reserved.
							I/O EMC_A20 — External memory address line 20.
							I/O GPIO7[2] — General purpose digital input/output pin.
							- R — Function reserved.
							- R — Function reserved.
- R — Function reserved.							

Table 169. LPC1850/30/20/10 Pin description (flashless parts) ...continued
 LCD, Ethernet, USB0, and USB1 functions are not available on all parts.

Symbol	LBGA256	TFBGA180	TFBGA100	LQFP144	Reset state [1]	Type	Description
PE_3	K12	K10	-	-	[2]	N; PU	- R — Function reserved.
							O CAN0_TD — CAN transmitter output.
							I ADCTRIG1 — ADC trigger input 1.
							I/O EMC_A21 — External memory address line 21.
							I/O GPIO7[3] — General purpose digital input/output pin.
							- R — Function reserved.
							- R — Function reserved.
PE_4	K13	J11	-	-	[2]	N; PU	- R — Function reserved.
							I NMI — External interrupt input to NMI.
							- R — Function reserved.
							I/O EMC_A22 — External memory address line 22.
							I/O GPIO7[4] — General purpose digital input/output pin.
							- R — Function reserved.
							- R — Function reserved.
PE_5	N16	-	-	-	[2]	N; PU	- R — Function reserved.
							O CTOUT_3 — SCT output 3. Match output 3 of timer 0.
							O U1_RTS — Request to Send output for UART1. Can also be configured to be an RS-485/EIA-485 output enable signal for UART1.
							I/O EMC_D24 — External memory data line 24.
							I/O GPIO7[5] — General purpose digital input/output pin.
							- R — Function reserved.
							- R — Function reserved.
PE_6	M16	-	-	-	[2]	N; PU	- R — Function reserved.
							O CTOUT_2 — SCT output 2. Match output 2 of timer 0.
							I U1_RI — Ring Indicator input for UART1.
							I/O EMC_D25 — External memory data line 25.
							I/O GPIO7[6] — General purpose digital input/output pin.
							- R — Function reserved.
							- R — Function reserved.
- R — Function reserved.							

Table 169. LPC1850/30/20/10 Pin description (flashless parts) ...continued
 LCD, Ethernet, USB0, and USB1 functions are not available on all parts.

Symbol	LBGA256	TFBGA180	TFBGA100	LQFP144	Reset state	Type	Description
PE_7	F15	-	-	-	[2]	N; PU	- R — Function reserved.
							O CTOUT_5 — SCT output 5. Match output 3 of timer 3.
							I U1_CTS — Clear to Send input for UART1.
							I/O EMC_D26 — External memory data line 26.
							I/O GPIO7[7] — General purpose digital input/output pin.
							- R — Function reserved.
							- R — Function reserved.
PE_8	F14	-	-	-	[2]	N; PU	- R — Function reserved.
							O CTOUT_4 — SCT output 4. Match output 3 of timer 3.
							I U1_DSR — Data Set Ready input for UART1.
							I/O EMC_D27 — External memory data line 27.
							I/O GPIO7[8] — General purpose digital input/output pin.
							- R — Function reserved.
							- R — Function reserved.
PE_9	E16	-	-	-	[2]	N; PU	- R — Function reserved.
							I CTIN_4 — SCT input 4. Capture input 2 of timer 1.
							I U1_DCD — Data Carrier Detect input for UART1.
							I/O EMC_D28 — External memory data line 28.
							I/O GPIO7[9] — General purpose digital input/output pin.
							- R — Function reserved.
							- R — Function reserved.
PE_10	E14	-	-	-	[2]	N; PU	- R — Function reserved.
							I CTIN_3 — SCT input 3. Capture input 1 of timer 1.
							O U1_DTR — Data Terminal Ready output for UART1. Can also be configured to be an RS-485/EIA-485 output enable signal for UART1.
							I/O EMC_D29 — External memory data line 29.
							I/O GPIO7[10] — General purpose digital input/output pin.
							- R — Function reserved.
							- R — Function reserved.
- R — Function reserved.							

Table 169. LPC1850/30/20/10 Pin description (flashless parts) ...continued
 LCD, Ethernet, USB0, and USB1 functions are not available on all parts.

Symbol	LBGA256	TFBGA180	TFBGA100	LQFP144	Reset state	Type	Description
PE_11	D16	-	-	-	[2]	N; PU	- R — Function reserved.
							O CTOUT_12 — SCT output 12. Match output 3 of timer 3.
							O U1_TXD — Transmitter output for UART1.
							I/O EMC_D30 — External memory data line 30.
							I/O GPIO7[11] — General purpose digital input/output pin.
							- R — Function reserved.
							- R — Function reserved.
PE_12	D15	-	-	-	[2]	N; PU	- R — Function reserved.
							O CTOUT_11 — SCT output 11. Match output 3 of timer 2.
							I U1_RXD — Receiver input for UART1.
							I/O EMC_D31 — External memory data line 31.
							I/O GPIO7[12] — General purpose digital input/output pin.
							- R — Function reserved.
							- R — Function reserved.
PE_13	G14	-	-	-	[2]	N; PU	- R — Function reserved.
							O CTOUT_14 — SCT output 14. Match output 2 of timer 3.
							I/O I2C1_SDA — I ² C1 data input/output (this pin does not use a specialized I ² C pad).
							O EMC_DQMOUT3 — Data mask 3 used with SDRAM and static devices.
							I/O GPIO7[13] — General purpose digital input/output pin.
							- R — Function reserved.
							- R — Function reserved.
PE_14	C15	-	-	-	[2]	N; PU	- R — Function reserved.
							- R — Function reserved.
							- R — Function reserved.
							O EMC_DYCS3 — SDRAM chip select 3.
							I/O GPIO7[14] — General purpose digital input/output pin.
							- R — Function reserved.
							- R — Function reserved.
- R — Function reserved.							

Table 169. LPC1850/30/20/10 Pin description (flashless parts) ...continued
 LCD, Ethernet, USB0, and USB1 functions are not available on all parts.

Symbol	LBGA256	TFBGA180	TFBGA100	LQFP144	Reset state [1]	Type	Description
PE_15	E13	-	-	-	[2]	N; PU	- R — Function reserved.
							O CTOUT_0 — SCT output 0. Match output 0 of timer 0.
							I/O I2C1_SCL — I ² C1 clock input/output (this pin does not use a specialized I ² C pad).
							O EMC_CKEOUT3 — SDRAM clock enable 3.
							I/O GPIO7[15] — General purpose digital input/output pin.
							- R — Function reserved.
							- R — Function reserved.
PF_0	D12	-	-	-	[2]	OL; PU	I/O SSP0_SCK — Serial clock for SSP0.
							I GP_CLKIN — General purpose clock input to the CGU.
							- R — Function reserved.
							- R — Function reserved.
							- R — Function reserved.
							- R — Function reserved.
							- R — Function reserved.
O I2S1_TX_MCLK — I ² S1 transmit master clock.							
PF_1	E11	-	-	-	[2]	N; PU	- R — Function reserved.
							- R — Function reserved.
							I/O SSP0_SSEL — Slave Select for SSP0.
							- R — Function reserved.
							I/O GPIO7[16] — General purpose digital input/output pin.
							- R — Function reserved.
							- R — Function reserved.
- R — Function reserved.							
PF_2	D11	-	-	-	[2]	N; PU	- R — Function reserved.
							O U3_TXD — Transmitter output for USART3.
							I/O SSP0_MISO — Master In Slave Out for SSP0.
							- R — Function reserved.
							I/O GPIO7[17] — General purpose digital input/output pin.
							- R — Function reserved.
							- R — Function reserved.
- R — Function reserved.							

Table 169. LPC1850/30/20/10 Pin description (flashless parts) ...continued
 LCD, Ethernet, USB0, and USB1 functions are not available on all parts.

Symbol	LBGA256	TFBGA180	TFBGA100	LQFP144	Reset state	Type	Description
PF_3	E10	-	-	-	[2] N; PU	-	R — Function reserved.
						I	U3_RXD — Receiver input for USART3.
						I/O	SSP0_MOSI — Master Out Slave in for SSP0.
						-	R — Function reserved.
						I/O	GPIO7[18] — General purpose digital input/output pin.
						-	R — Function reserved.
PF_4	D10	D6	H4	120	[2] OL; PU	I/O	SSP1_SCK — Serial clock for SSP1.
						I	GP_CLKIN — General purpose clock input to the CGU.
						O	TRACECLK — Trace clock.
						-	R — Function reserved.
						-	R — Function reserved.
						-	R — Function reserved.
						O	I2S0_TX_MCLK — I ² S transmit master clock.
						I/O	I2S0_RX_SCK — I ² S receive clock. It is driven by the master and received by the slave. Corresponds to the signal SCK in the <i>I²S-bus specification</i> .
PF_5	E9	-	-	-	[5] N; PU	-	R — Function reserved.
						I/O	U3_UCLK — Serial clock input/output for USART3 in synchronous mode.
						I/O	SSP1_SSEL — Slave Select for SSP1.
						O	TRACEDATA[0] — Trace data, bit 0.
						I/O	GPIO7[19] — General purpose digital input/output pin.
						-	R — Function reserved.
						-	R — Function reserved.
						-	R — Function reserved.
AI	ADC1_4 — ADC1 and ADC0, input channel 4. Configure the pin as GPIO input and use the ADC function select register in the SCU to select the ADC.						

Table 169. LPC1850/30/20/10 Pin description (flashless parts) ...continued
 LCD, Ethernet, USB0, and USB1 functions are not available on all parts.

Symbol	LBGA256	TFBGA180	TFBGA100	LQFP144	Reset state [5]	Type	Description
PF_6	E7	-	-	-	[5]	N; PU	- R — Function reserved.
							I/O U3_DIR — RS-485/EIA-485 output enable/direction control for USART3.
							I/O SSP1_MISO — Master In Slave Out for SSP1.
							O TRACEDATA[1] — Trace data, bit 1.
							I/O GPIO7[20] — General purpose digital input/output pin.
							- R — Function reserved.
							- R — Function reserved.
I/O I2S1_TX_SDA — I ² S1 transmit data. It is driven by the transmitter and read by the receiver. Corresponds to the signal SD in the <i>I²S-bus specification</i> .							
AI ADC1_3 — ADC1 and ADC0, input channel 3. Configure the pin as GPIO input and use the ADC function select register in the SCU to select the ADC.							
PF_7	B7	-	-	-	[5]	N; PU	- R — Function reserved.
							I/O U3_BAUD — Baud pin USART3.
							I/O SSP1_MOSI — Master Out Slave in for SSP1.
							O TRACEDATA[2] — Trace data, bit 2.
							I/O GPIO7[21] — General purpose digital input/output pin.
							- R — Function reserved.
							- R — Function reserved.
I/O I2S1_TX_WS — Transmit Word Select. It is driven by the master and received by the slave. Corresponds to the signal WS in the <i>I²S-bus specification</i> .							
AI/O ADC1_7 — ADC1 and ADC0, input channel 7 or band gap output. Configure the pin as GPIO input and use the ADC function select register in the SCU to select the ADC.							
PF_8	E6	-	-	-	[5]	N; PU	- R — Function reserved.
							I/O U0_UCLK — Serial clock input/output for USART0 in synchronous mode.
							I CTIN_2 — SCT input 2. Capture input 2 of timer 0.
							O TRACEDATA[3] — Trace data, bit 3.
							I/O GPIO7[22] — General purpose digital input/output pin.
							- R — Function reserved.
							- R — Function reserved.
- R — Function reserved.							
AI ADC0_2 — ADC0 and ADC1, input channel 2. Configure the pin as GPIO input and use the ADC function select register in the SCU to select the ADC.							

Table 169. LPC1850/30/20/10 Pin description (flashless parts) ...continued
 LCD, Ethernet, USB0, and USB1 functions are not available on all parts.

Symbol	LBGA256	TFBGA180	TFBGA100	LQFP144	Reset state [1]	Type	Description
PF_9	D6	-	-	-	[5]	N; PU	- R — Function reserved.
							I/O U0_DIR — RS-485/EIA-485 output enable/direction control for USART0.
							O CTOUT_1 — SCT output 1. Match output 3 of timer 3.
							- R — Function reserved.
							I/O GPIO7[23] — General purpose digital input/output pin.
							- R — Function reserved.
							- R — Function reserved.
AI ADC1_2 — ADC1 and ADC0, input channel 2. Configure the pin as GPIO input and use the ADC function select register in the SCU to select the ADC.							
PF_10	A3	-	-	-	[5]	N; PU	- R — Function reserved.
							O U0_TXD — Transmitter output for USART0.
							- R — Function reserved.
							- R — Function reserved.
							I/O GPIO7[24] — General purpose digital input/output pin.
							- R — Function reserved.
							I SD_WP — SD/MMC card write protect input.
AI ADC0_5 — ADC0 and ADC1, input channel 5. Configure the pin as GPIO input and use the ADC function select register in the SCU to select the ADC.							
PF_11	A2	-	-	-	[5]	N; PU	- R — Function reserved.
							I U0_RXD — Receiver input for USART0.
							- R — Function reserved.
							- R — Function reserved.
							I/O GPIO7[25] — General purpose digital input/output pin.
							- R — Function reserved.
							O SD_VOLT2 — SD/MMC bus voltage select output 2.
AI ADC1_5 — ADC1 and ADC0, input channel 5. Configure the pin as GPIO input and use the ADC function select register in the SCU to select the ADC.							

Table 169. LPC1850/30/20/10 Pin description (flashless parts) ...continued
 LCD, Ethernet, USB0, and USB1 functions are not available on all parts.

Symbol	LBGA256	TFBGA180	TFBGA100	LQFP144	Reset state [1]	Type	Description
Clock pins							
CLK0	N5	M4	K3	45	[4]	O; PU	O EMC_CLK0 — SDRAM clock 0. O CLKOUT — Clock output pin. - R — Function reserved. - R — Function reserved. I/O SD_CLK — SD/MMC card clock. O EMC_CLK01 — SDRAM clock 0 and clock 1 combined. I/O SSP1_SCK — Serial clock for SSP1. I ENET_TX_CLK (ENET_REF_CLK) — Ethernet Transmit Clock (MII interface) or Ethernet Reference Clock (RMII interface).
CLK1	T10	-	-	-	[4]	O; PU	O EMC_CLK1 — SDRAM clock 1. O CLKOUT — Clock output pin. - R — Function reserved. - R — Function reserved. - R — Function reserved. O CGU_OUT0 — CGU spare clock output 0. - R — Function reserved. O I2S1_TX_MCLK — I2S1 transmit master clock.
CLK2	D14	P10	K6	99	[4]	O; PU	O EMC_CLK3 — SDRAM clock 3. O CLKOUT — Clock output pin. - R — Function reserved. - R — Function reserved. I/O SD_CLK — SD/MMC card clock. O EMC_CLK23 — SDRAM clock 2 and clock 3 combined. O I2S0_TX_MCLK — I2S transmit master clock. I/O I2S1_RX_SCK — Receive Clock. It is driven by the master and received by the slave. Corresponds to the signal SCK in the <i>I2S-bus specification</i> .
CLK3	P12	-	-	-	[4]	O; PU	O EMC_CLK2 — SDRAM clock 2. O CLKOUT — Clock output pin. - R — Function reserved. - R — Function reserved. - R — Function reserved. O CGU_OUT1 — CGU spare clock output 1. - R — Function reserved. I/O I2S1_RX_SCK — Receive Clock. It is driven by the master and received by the slave. Corresponds to the signal SCK in the <i>I2S-bus specification</i> .

Table 169. LPC1850/30/20/10 Pin description (flashless parts) ...continued
 LCD, Ethernet, USB0, and USB1 functions are not available on all parts.

Symbol	LBGA256	TFBGA180	TFBGA100	LQFP144		Reset state [1]	Type	Description
Debug pins								
DBGEN	L4	K4	A6	28	[2]	I	I	JTAG interface control signal. Also used for boundary scan.
TCK/SWDCLK	J5	G5	H2	27	[2]	I; F	I	Test Clock for JTAG interface (default) or Serial Wire (SW) clock.
TRST	M4	L4	B4	29	[2]	I; PU	I	Test Reset for JTAG interface.
TMS/SWDIO	K6	K5	C4	30	[2]	I; PU	I	Test Mode Select for JTAG interface (default) or SW debug data input/output.
TDO/SWO	K5	J5	H3	31	[2]	O	O	Test Data Out for JTAG interface (default) or SW trace output.
TDI	J4	H4	G3	26	[2]	I; PU	I	Test Data In for JTAG interface.
USB0 pins								
USB0_DP	F2	E2	E1	18	[6]	-	I/O	USB0 bidirectional D+ line. Do not add an external series resistor.
USB0_DM	G2	F2	E2	20	[6]	-	I/O	USB0 bidirectional D- line. Do not add an external series resistor.
USB0_VBUS	F1	E1	E3	21	[6] [7]	-	I/O	VBUS pin (power on USB cable). This pin includes an internal pull-down resistor of 64 k Ω (typical) \pm 16 k Ω .
USB0_ID	H2	G2	F1	22	[8]	-	I	Indicates to the transceiver whether connected as an A-device (USB0_ID LOW) or B-device (USB0_ID HIGH). For OTG, this pin has an internal pull-up resistor.
USB0_RREF	H1	G1	F3	24	[8]	-		12.0 k Ω (accuracy 1 %) on-board resistor to ground for current reference.
USB1 pins								
USB1_DP	F12	D11	E9	89	[9]	-	I/O	USB1 bidirectional D+ line. Add an external series resistor of 33 Ω +/- 2 %.
USB1_DM	G12	E11	E10	90	[9]	-	I/O	USB1 bidirectional D- line. Add an external series resistor of 33 Ω +/- 2 %.
I²C-bus pins								
I2C0_SCL	L15	K13	D6	92	[10]	I; F	I/O	I ² C clock input/output. Open-drain output (for I ² C-bus compliance).
I2C0_SDA	L16	K14	E6	93	[10]	I; F	I/O	I ² C data input/output. Open-drain output (for I ² C-bus compliance).
Reset and wake-up pins								
RESET	D9	C7	B6	128	[11]	I; IA	I	External reset input: A LOW-going pulse as short as 50 ns on this pin resets the device, causing I/O ports and peripherals to take on their default states, and processor execution to begin at address 0.
WAKEUP0	A9	A9	A4	130	[11]	I; IA	I	External wake-up input; can raise an interrupt and can cause wake-up from any of the low power modes. A pulse with a duration of at least 45 ns wakes up the part.
WAKEUP1	A10	C8	-	-	[11]	I; IA	I	External wake-up input; can raise an interrupt and can cause wake-up from any of the low power modes. A pulse with a duration of at least 45 ns wakes up the part.

Table 169. LPC1850/30/20/10 Pin description (flashless parts) ...continued
 LCD, Ethernet, USB0, and USB1 functions are not available on all parts.

Symbol	LBGA256	TFBGA180	TFBGA100	LQFP144	Reset state [1]	Type	Description	
WAKEUP2	C9	E5	-	-	[11]	I; IA	I	External wake-up input; can raise an interrupt and can cause wake-up from any of the low power modes. A pulse with a duration of at least 45 ns wakes up the part.
WAKEUP3	D8	-	-	-	[11]	I; IA	I	External wake-up input; can raise an interrupt and can cause wake-up from any of the low power modes. A pulse with a duration of at least 45 ns wakes up the part.
ADC pins								
ADC0_0/ ADC1_0/DAC	E3	B6	A2	6	[8]	AI/O; IA	I	ADC input channel 0. Shared between 10-bit ADC0/1 and DAC.
ADC0_1/ ADC1_1	C3	C4	A1	2	[8]	AI; IA	I	ADC input channel 1. Shared between 10-bit ADC0/1.
ADC0_2/ ADC1_2	A4	B3	B3	143	[8]	AI; IA	I	ADC input channel 2. Shared between 10-bit ADC0/1.
ADC0_3/ ADC1_3	B5	B4	A3	139	[8]	AI; IA	I	ADC input channel 3. Shared between 10-bit ADC0/1.
ADC0_4/ ADC1_4	C6	A5	-	138	[8]	AI; IA	I	ADC input channel 4. Shared between 10-bit ADC0/1.
ADC0_5/ ADC1_5	B3	C3	-	144	[8]	AI; IA	I	ADC input channel 5. Shared between 10-bit ADC0/1.
ADC0_6/ ADC1_6	A5	A4	-	142	[8]	AI; IA	I	ADC input channel 6. Shared between 10-bit ADC0/1.
ADC0_7/ ADC1_7	C5	B5	-	136	[8]	AI; IA	I	ADC input channel 7. Shared between 10-bit ADC0/1.
RTC								
RTC_ALARM	A11	A10	C3	129	[11]	-	O	RTC controlled output.
RTCX1	A8	A8	A5	125	[8]	-	I	Input to the RTC 32 kHz ultra-low power oscillator circuit.
RTCX2	B8	B7	B5	126	[8]	-	O	Output from the RTC 32 kHz ultra-low power oscillator circuit.
Crystal oscillator pins								
XTAL1	D1	C1	B1	12	[8]	-	I	Input to the oscillator circuit and internal clock generator circuits.
XTAL2	E1	D1	C1	13	[8]	-	O	Output from the oscillator amplifier.
Power and ground pins								
USB0_VDDA 3V3_DRIVER	F3	E3	D1	16	-	-	-	Separate analog 3.3 V power supply for driver.
USB0 _VDDA3V3	G3	F3	D2	17	-	-	-	USB 3.3 V separate power supply voltage.
USB0_VSSA _TERM	H3	G3	D3	19	-	-	-	Dedicated analog ground for clean reference for termination resistors.
USB0_VSSA _REF	G1	F1	F2	23	-	-	-	Dedicated clean analog ground for generation of reference currents and voltages.
VDDA	B4	A6	B2	137	-	-	-	Analog power supply and ADC reference voltage.

Table 169. LPC1850/30/20/10 Pin description (flashless parts) ...continued
 LCD, Ethernet, USB0, and USB1 functions are not available on all parts.

Symbol	LBGA256	TFBGA180	TFBGA100	LQFP144	Reset state [1]	Type	Description
VBAT	B10	B9	C5	127	-	-	RTC power supply: 3.3 V on this pin supplies power to the RTC.
VDDREG	F10, F9, L8, L7	D8, E8	E4, E5, F4	94, 131, 59, 25	-	-	Main regulator power supply. Tie the VDDREG and VDDIO pins to a common power supply to ensure the same ramp-up time for both supply voltages.
VPP	E8	-	-	-	[12]	-	OTP programming voltage.
VDDIO	D7, E12, F7, F8, G10, H10, J6, J7, K7, L9, L10, N7, N13	H5, H10, K8, G10	F10, K5	5, 36, 41, 71, 77, 107, 111, 141	[12]	-	I/O power supply. Tie the VDDREG and VDDIO pins to a common power supply to ensure the same ramp-up time for both supply voltages.
VSS	G9, H7, J10, J11, K8	F10, D7, E6, E7, E9, K6, K9	C8, D4, D5, G8, J3, J6	-	[13]	-	Ground.
VSSIO	C4, D13, G6, G7, G8, H8, H9, J8, J9, K9, K10, M13, P7, P13	-	-	4, 40, 76, 109	[13]	-	Ground.
VSSA	B2	A3	C2	135	-	-	Analog ground.
Not connected							
-	B9	B8	-	-	-	-	n.c.

[1] N = neutral, input buffer disabled; no extra VDDIO current consumption if the input is driven midway between supplies; set the EZI bit in the SFS register to enable the input buffer; I = input; OL = output driving LOW; OH = output driving HIGH; AI/O = analog input/output; IA = inactive; PU = pull-up enabled (weak pull-up resistor pulls up pin to VDDIO; F = floating. Reset state reflects the pin state at reset without boot code operation.

- [2] 5 V tolerant pad with 15 ns glitch filter (5 V tolerant if VDDIO present; if VDDIO not present, do not exceed 3.6 V); provides digital I/O functions with TTL levels and hysteresis; normal drive strength.
- [3] 5 V tolerant pad with 15 ns glitch filter (5 V tolerant if VDDIO present; if VDDIO not present, do not exceed 3.6 V); provides digital I/O functions with TTL levels, and hysteresis; high drive strength.
- [4] 5 V tolerant pad with 15 ns glitch filter (5 V tolerant if VDDIO present; if VDDIO not present, do not exceed 3.6 V); provides high-speed digital I/O functions with TTL levels and hysteresis.
- [5] 5 V tolerant pad providing digital I/O functions (with TTL levels and hysteresis) and analog input or output (5 V tolerant if VDDIO present; if VDDIO not present, do not exceed 3.6 V). When configured as a ADC input or DAC output, the pin is not 5 V tolerant and the digital section of the pad must be disabled by setting the pin to an input function and disabling the pull-up resistor through the pin's SFSP register.
- [6] 5 V tolerant transparent analog pad.
- [7] For maximum load $C_L = 6.5 \mu\text{F}$ and maximum pull-down resistance $R_{pd} = 80 \text{ k}\Omega$, the VBUS signal takes about 2 s to fall from VBUS = 5 V to VBUS = 0.2 V when it is no longer driven.
- [8] Transparent analog pad. Not 5 V tolerant.
- [9] Pad provides USB functions. It is designed in accordance with the USB specification, revision 2.0 (Full-speed and Low-speed mode only).
- [10] Open-drain 5 V tolerant digital I/O pad, compatible with I²C-bus Fast Mode Plus specification. This pad requires an external pull-up to provide output functionality. When power is switched off, this pin connected to the I²C-bus is floating and does not disturb the I²C lines.
- [11] 5 V tolerant pad with 20 ns glitch filter; provides digital I/O functions with open-drain output with weak pull-up resistor and hysteresis.
- [12] If not pinned out, VPP is internally connected to VDDIO.
- [13] On the TFBGA100 package, VSS is internally connected to VSSIO.

Table 170. LPC18xx Pin description (flash-based parts)

Pin name	LPGA256	TFBGA100	LQFP144	LQFP208	Reset state	Type	Description
Multiplexed digital pins							
P0_0	L3	G2	32	47	N; PU	I/O	GPIO0[0] — General purpose digital input/output pin.
						I/O	SSP1_MISO — Master In Slave Out for SSP1.
						I	ENET_RXD1 — Ethernet receive data 1 (RMII/MII interface).
						-	R — Function reserved.
						-	R — Function reserved.
						-	R — Function reserved.
P0_1	M2	G1	34	50	N; PU	I/O	GPIO0[1] — General purpose digital input/output pin.
						I/O	SSP1_MOSI — Master Out Slave in for SSP1.
						I	ENET_COL — Ethernet Collision detect (MII interface).
						-	R — Function reserved.
P1_0	P2	H1	38	54	N; PU	I/O	GPIO0[4] — General purpose digital input/output pin.
						I	CTIN_3 — SCT input 3. Capture input 1 of timer 1.
						I/O	EMC_A5 — External memory address line 5.
						-	R — Function reserved.
						-	R — Function reserved.
						I/O	SSP0_SSEL — Slave Select for SSP0.
-	R — Function reserved.						
						I/O	EMC_D12 — External memory data line 12.

Table 170. LPC18xx Pin description (flash-based parts) ...continued

Pin name	LBGA256	TFBGA100	LQFP144	LQFP208	Reset state [1]	Type	Description							
P1_1	R2	K2	42	58	[2] N; PU	I/O	GPIO0[8] — General purpose digital input/output pin. External boot pin (see Table 16).							
							O	CTOUT_7 — SCT output 7. Match output 3 of timer 1.						
							I/O	EMC_A6 — External memory address line 6.						
							-	R — Function reserved.						
							-	R — Function reserved.						
							I/O	SSP0_MISO — Master In Slave Out for SSP0.						
							-	R — Function reserved.						
							I/O	EMC_D13 — External memory data line 13.						
							P1_2	R3	K1	43	60	[2] N; PU	I/O	GPIO0[9] — General purpose digital input/output pin. External boot pin (see Table 16).
														O
I/O	EMC_A7 — External memory address line 7.													
-	R — Function reserved.													
-	R — Function reserved.													
I/O	SSP0_MOSI — Master Out Slave in for SSP0.													
-	R — Function reserved.													
I/O	EMC_D14 — External memory data line 14.													
P1_3	P5	J1	44	61	[2] N; PU	I/O								GPIO0[10] — General purpose digital input/output pin.
														O
							-	R — Function reserved.						
							O	EMC_OE — LOW active Output Enable signal.						
							O	USB0_IND1 — USB0 port indicator LED control output 1.						
							I/O	SSP1_MISO — Master In Slave Out for SSP1.						
							-	R — Function reserved.						
							O	SD_RST — SD/MMC reset signal for MMC4.4 card.						
							P1_4	T3	J2	47	64	[2] N; PU	I/O	GPIO0[11] — General purpose digital input/output pin.
														O
-	R — Function reserved.													
O	EMC_BLS0 — LOW active Byte Lane select signal 0.													
O	USB0_IND0 — USB0 port indicator LED control output 0.													
I/O	SSP1_MOSI — Master Out Slave in for SSP1.													
I/O	EMC_D15 — External memory data line 15.													
O	SD_VOLT1 — SD/MMC bus voltage select output 1.													

Table 170. LPC18xx Pin description (flash-based parts) ...continued

Pin name	LPGA256	TFBGA100	LQFP144	LQFP208	Reset state	Type	Description
P1_5	R5	J4	48	65	N; PU	I/O	GPIO1[8] — General purpose digital input/output pin.
						O	CTOUT_10 — SCT output 10. Match output 3 of timer 3.
						-	R — Function reserved.
						O	EMC_CS0 — LOW active Chip Select 0 signal.
						I	USB0_PWR_FAULT — Port power fault signal indicating overcurrent condition; this signal monitors over-current on the USB bus (external circuitry required to detect over-current condition).
						I/O	SSP1_SSEL — Slave Select for SSP1.
						-	R — Function reserved.
P1_6	T4	K4	49	67	N; PU	I/O	GPIO1[9] — General purpose digital input/output pin.
						I	CTIN_5 — SCT input 5. Capture input 2 of timer 2.
						-	R — Function reserved.
						O	EMC_WE — LOW active Write Enable signal.
						-	R — Function reserved.
						O	EMC_BLS0 — LOW active Byte Lane select signal 0.
						-	R — Function reserved.
P1_7	T5	G4	50	69	N; PU	I/O	GPIO1[0] — General purpose digital input/output pin.
						I	U1_DSR — Data Set Ready input for UART1.
						O	CTOUT_13 — SCT output 13. Match output 3 of timer 3.
						I/O	EMC_D0 — External memory data line 0.
						O	USB0_PPWR — VBUS drive signal (towards external charge pump or power management unit); indicates that VBUS must be driven (active HIGH). Add a pull-down resistor to disable the power switch at reset. This signal has opposite polarity compared to the USB_PPWR used on other NXP LPC parts.
						-	R — Function reserved.
						-	R — Function reserved.
P1_8	R7	H5	51	71	N; PU	I/O	GPIO1[1] — General purpose digital input/output pin.
						O	U1_DTR — Data Terminal Ready output for UART1.
						O	CTOUT_12 — SCT output 12. Match output 3 of timer 3.
						I/O	EMC_D1 — External memory data line 1.
						-	R — Function reserved.
						-	R — Function reserved.
						-	R — Function reserved.
						O	SD_VOLT0 — SD/MMC bus voltage select output 0.

Table 170. LPC18xx Pin description (flash-based parts) ...continued

Pin name	LBGA256	TFBGA100	LQFP144	LQFP208	Reset state [2]	Type [1]	Description
P1_9	T7	J5	52	73	[2]	N; PU	I/O GPIO1[2] — General purpose digital input/output pin.
							O U1_RTS — Request to Send output for UART1.
							O CTOUT_11 — SCT output 11. Match output 3 of timer 2.
							I/O EMC_D2 — External memory data line 2.
							- R — Function reserved.
							- R — Function reserved.
							- R — Function reserved.
P1_10	R8	H6	53	75	[2]	N; PU	I/O GPIO1[3] — General purpose digital input/output pin.
							I U1_RI — Ring Indicator input for UART1.
							O CTOUT_14 — SCT output 14. Match output 2 of timer 3.
							I/O EMC_D3 — External memory data line 3.
							- R — Function reserved.
							- R — Function reserved.
							- R — Function reserved.
P1_11	T9	J7	55	77	[2]	N; PU	I/O GPIO1[4] — General purpose digital input/output pin.
							I U1_CTS — Clear to Send input for UART1.
							O CTOUT_15 — SCT output 15. Match output 3 of timer 3.
							I/O EMC_D4 — External memory data line 4.
							- R — Function reserved.
							- R — Function reserved.
							- R — Function reserved.
P1_12	R9	K7	56	78	[2]	N; PU	I/O GPIO1[5] — General purpose digital input/output pin.
							I U1_DCD — Data Carrier Detect input for UART1.
							- R — Function reserved.
							I/O EMC_D5 — External memory data line 5.
							I T0_CAP1 — Capture input 1 of timer 0.
							- R — Function reserved.
							- R — Function reserved.
I/O SD_DAT3 — SD/MMC data bus line 3.							

Table 170. LPC18xx Pin description (flash-based parts) ...continued

Pin name	LBGA256	TFBGA100	LQFP144	LQFP208	Reset state [2]	Type [1]	Description
P1_13	R10	H8	60	83	[2]	N; PU	I/O GPIO1[6] — General purpose digital input/output pin.
							O U1_TXD — Transmitter output for UART1.
							- R — Function reserved.
							I/O EMC_D6 — External memory data line 6.
							I T0_CAP0 — Capture input 0 of timer 0.
							- R — Function reserved.
							- R — Function reserved.
P1_14	R11	J8	61	85	[2]	N; PU	I/O GPIO1[7] — General purpose digital input/output pin.
							I U1_RXD — Receiver input for UART1.
							- R — Function reserved.
							I/O EMC_D7 — External memory data line 7.
							O T0_MAT2 — Match output 2 of timer 0.
							- R — Function reserved.
							- R — Function reserved.
P1_15	T12	K8	62	87	[2]	N; PU	I/O GPIO0[2] — General purpose digital input/output pin.
							O U2_TXD — Transmitter output for USART2.
							- R — Function reserved.
							I ENET_RXD0 — Ethernet receive data 0 (RMII/MII interface).
							O T0_MAT1 — Match output 1 of timer 0.
							- R — Function reserved.
							I/O EMC_D8 — External memory data line 8.
- R — Function reserved.							
P1_16	M7	H9	64	90	[2]	N; PU	I/O GPIO0[3] — General purpose digital input/output pin.
							I U2_RXD — Receiver input for USART2.
							- R — Function reserved.
							I ENET_CRS — Ethernet Carrier Sense (MII interface).
							O T0_MAT0 — Match output 0 of timer 0.
							- R — Function reserved.
							I/O EMC_D9 — External memory data line 9.
I ENET_RX_DV — Ethernet Receive Data Valid (RMII/MII interface).							

Table 170. LPC18xx Pin description (flash-based parts) ...continued

Pin name	LPGA256	TFBGA100	LQFP144	LQFP208	Reset state	Type	Description
P1_17	M8	H10	66	93	N; PU	I/O	GPIO0[12] — General purpose digital input/output pin.
						I/O	U2_UCLK — Serial clock input/output for USART2 in synchronous mode.
						-	R — Function reserved.
						I/O	ENET_MDIO — Ethernet MIIM data input and output.
						I	T0_CAP3 — Capture input 3 of timer 0.
						O	CAN1_TD — CAN1 transmitter output.
						-	R — Function reserved.
P1_18	N12	J10	67	95	N; PU	I/O	GPIO0[13] — General purpose digital input/output pin.
						I/O	U2_DIR — RS-485/EIA-485 output enable/direction control for USART2.
						-	R — Function reserved.
						O	ENET_TXD0 — Ethernet transmit data 0 (RMII/MII interface).
						O	T0_MAT3 — Match output 3 of timer 0.
						I	CAN1_RD — CAN1 receiver input.
						-	R — Function reserved.
P1_19	M11	K9	68	96	N; PU	I	ENET_TX_CLK (ENET_REF_CLK) — Ethernet Transmit Clock (MII interface) or Ethernet Reference Clock (RMII interface).
						I/O	SSP1_SCK — Serial clock for SSP1.
						-	R — Function reserved.
						-	R — Function reserved.
						O	CLKOUT — Clock output pin.
						-	R — Function reserved.
						O	I2S0_RX_MCLK — I ² S receive master clock.
P1_20	M10	K10	70	100	N; PU	I/O	GPIO0[15] — General purpose digital input/output pin.
						I/O	SSP1_SSEL — Slave Select for SSP1.
						-	R — Function reserved.
						O	ENET_TXD1 — Ethernet transmit data 1 (RMII/MII interface).
						I	T0_CAP2 — Capture input 2 of timer 0.
						-	R — Function reserved.
						-	R — Function reserved.
I/O	EMC_D11 — External memory data line 11.						

Table 170. LPC18xx Pin description (flash-based parts) ...continued

Pin name	LBGA256	TFBGA100	LQFP144	LQFP208	Reset state [2]	Type [1]	Description
P2_0	T16	G10	75	108	[2]	N; PU	- R — Function reserved.
							O U0_TXD — Transmitter output for USART0. See Table 15 for ISP mode.
							I/O EMC_A13 — External memory address line 13.
							O USB0_PPWR — VBUS drive signal (towards external charge pump or power management unit); indicates that VBUS must be driven (active HIGH). Add a pull-down resistor to disable the power switch at reset. This signal has opposite polarity compared to the USB_PPWR used on other NXP LPC parts.
							I/O GPIO5[0] — General purpose digital input/output pin.
							- R — Function reserved.
							I T3_CAP0 — Capture input 0 of timer 3.
							O ENET_MDC — Ethernet MIIM clock.
P2_1	N15	G7	81	116	[2]	N; PU	- R — Function reserved.
							I U0_RXD — Receiver input for USART0. See Table 15 for ISP mode.
							I/O EMC_A12 — External memory address line 12.
							I USB0_PWR_FAULT — Port power fault signal indicating overcurrent condition; this signal monitors over-current on the USB bus (external circuitry required to detect over-current condition).
							I/O GPIO5[1] — General purpose digital input/output pin.
							- R — Function reserved.
							I T3_CAP1 — Capture input 1 of timer 3.
							- R — Function reserved.
P2_2	M15	F5	84	121	[2]	N; PU	- R — Function reserved.
							I/O U0_UCLK — Serial clock input/output for USART0 in synchronous mode.
							I/O EMC_A11 — External memory address line 11.
							O USB0_IND1 — USB0 port indicator LED control output 1.
							I/O GPIO5[2] — General purpose digital input/output pin.
							I CTIN_6 — SCT input 6. Capture input 1 of timer 3.
							I T3_CAP2 — Capture input 2 of timer 3.
							O EMC_CS1 — LOW active Chip Select 1 signal.

Table 170. LPC18xx Pin description (flash-based parts) ...continued

Pin name	LPGA256	TFBGA100	LQFP144	LQFP208	Reset state	Type	Description
P2_3	J12	D8	87	127	N; PU	-	R — Function reserved.
						I/O	I2C1_SDA — I ² C1 data input/output (this pin does not use a specialized I ² C pad).
						O	U3_TXD — Transmitter output for USART3. See Table 15 for ISP mode.
						I	CTIN_1 — SCT input 1. Capture input 1 of timer 0. Capture input 1 of timer 2.
						I/O	GPIO5[3] — General purpose digital input/output pin.
						-	R — Function reserved.
						O	T3_MAT0 — Match output 0 of timer 3.
P2_4	K11	D9	88	128	N; PU	-	R — Function reserved.
						I/O	I2C1_SCL — I ² C1 clock input/output (this pin does not use a specialized I ² C pad).
						I	U3_RXD — Receiver input for USART3. See Table 15 for ISP mode.
						I	CTIN_0 — SCT input 0. Capture input 0 of timer 0, 1, 2, 3.
						I/O	GPIO5[4] — General purpose digital input/output pin.
						-	R — Function reserved.
						O	T3_MAT1 — Match output 1 of timer 3.
P2_5	K14	D10	91	131	N; PU	-	R — Function reserved.
						I	CTIN_2 — SCT input 2. Capture input 2 of timer 0.
						I	USB1_VBUS — Monitors the presence of USB1 bus power. Note: This signal must be HIGH for USB reset to occur.
						I	ADCTRIG1 — ADC trigger input 1.
						I/O	GPIO5[5] — General purpose digital input/output pin.
						-	R — Function reserved.
						O	T3_MAT2 — Match output 2 of timer 3.
	O	USB0_IND0 — USB0 port indicator LED control output 0.					

Table 170. LPC18xx Pin description (flash-based parts) ...continued

Pin name	LBGA256	TFBGA100	LQFP144	LQFP208	Reset state [1]	Type	Description
P2_6	K16	G9	95	137	N; PU	-	R — Function reserved.
						I/O	U0_DIR — RS-485/EIA-485 output enable/direction control for USART0.
						I/O	EMC_A10 — External memory address line 10.
						O	USB0_IND0 — USB0 port indicator LED control output 0.
						I/O	GPIO5[6] — General purpose digital input/output pin.
						I	CTIN_7 — SCT input 7.
						I	T3_CAP3 — Capture input 3 of timer 3.
P2_7	H14	C10	96	138	N; PU	O	EMC_BLS1 — LOW active Byte Lane select signal 1.
						I/O	GPIO0[7] — General purpose digital input/output pin. ISP entry pin. If this pin is pulled LOW at reset, the part enters ISP mode or boots from an external source (see Table 15 and Table 16).
						O	CTOUT_1 — SCT output 1. Match output 3 of timer 3.
						I/O	U3_UCLK — Serial clock input/output for USART3 in synchronous mode.
						I/O	EMC_A9 — External memory address line 9.
						-	R — Function reserved.
						-	R — Function reserved.
						O	T3_MAT3 — Match output 3 of timer 3.
						-	R — Function reserved.
						P2_8	J16
O	CTOUT_0 — SCT output 0. Match output 0 of timer 0.						
I/O	U3_DIR — RS-485/EIA-485 output enable/direction control for USART3.						
I/O	EMC_A8 — External memory address line 8.						
I/O	GPIO5[7] — General purpose digital input/output pin.						
-	R — Function reserved.						
-	R — Function reserved.						
P2_9	H16	B10	102	144	N; PU	-	R — Function reserved.
						I/O	GPIO1[10] — General purpose digital input/output pin. External boot pin (see Table 16).
						O	CTOUT_3 — SCT output 3. Match output 3 of timer 0.
						I/O	U3_BAUD — Baud pin for USART3.
						I/O	EMC_A0 — External memory address line 0.
						-	R — Function reserved.
						-	R — Function reserved.

Table 170. LPC18xx Pin description (flash-based parts) ...continued

Pin name	LBGA256	TFBGA100	LQFP144	LQFP208	Reset state [1]	Type	Description
P2_10	G16	E8	104	146	[2] N; PU	I/O	GPIO0[14] — General purpose digital input/output pin.
						O	CTOUT_2 — SCT output 2. Match output 2 of timer 0.
						O	U2_TXD — Transmitter output for USART2.
						I/O	EMC_A1 — External memory address line 1.
						-	R — Function reserved.
						-	R — Function reserved.
						-	R — Function reserved.
P2_11	F16	A9	105	148	[2] N; PU	I/O	GPIO1[11] — General purpose digital input/output pin.
						O	CTOUT_5 — SCT output 5. Match output 3 of timer 3.
						I	U2_RXD — Receiver input for USART2.
						I/O	EMC_A2 — External memory address line 2.
						-	R — Function reserved.
						-	R — Function reserved.
						-	R — Function reserved.
P2_12	E15	B9	106	153	[2] N; PU	I/O	GPIO1[12] — General purpose digital input/output pin.
						O	CTOUT_4 — SCT output 4. Match output 3 of timer 3.
						-	R — Function reserved.
						I/O	EMC_A3 — External memory address line 3.
						-	R — Function reserved.
						-	R — Function reserved.
						-	R — Function reserved.
P2_13	C16	A10	108	156	[2] N; PU	I/O	GPIO1[13] — General purpose digital input/output pin.
						I	CTIN_4 — SCT input 4. Capture input 2 of timer 1.
						-	R — Function reserved.
						I/O	EMC_A4 — External memory address line 4.
						-	R — Function reserved.
						-	R — Function reserved.
						-	R — Function reserved.
						I/O	U2_DIR — RS-485/EIA-485 output enable/direction control for USART2.

Table 170. LPC18xx Pin description (flash-based parts) ...continued

Pin name	LPGA256	TFBGA100	LQFP144	LQFP208	Reset state	Type	Description
P3_0	F13	A8	112	161	N; PU	I/O	I2S0_RX_SCK — I ² S receive clock. It is driven by the master and received by the slave. Corresponds to the signal SCK in the I ² S-bus specification.
							O I2S0_RX_MCLK — I ² S receive master clock.
							I/O I2S0_TX_SCK — Transmit Clock. It is driven by the master and received by the slave. Corresponds to the signal SCK in the I ² S-bus specification.
							O I2S0_TX_MCLK — I ² S transmit master clock.
							I/O SSP0_SCK — Serial clock for SSP0.
							- R — Function reserved.
							- R — Function reserved.
P3_1	G11	F7	114	163	N; PU	I/O	I2S0_TX_WS — Transmit Word Select. It is driven by the master and received by the slave. Corresponds to the signal WS in the I ² S-bus specification.
							I/O I2S0_RX_WS — Receive Word Select. It is driven by the master and received by the slave. Corresponds to the signal WS in the I ² S-bus specification.
							I CAN0_RD — CAN receiver input.
							O USB1_IND1 — USB1 Port indicator LED control output 1.
							I/O GPIO5[8] — General purpose digital input/output pin.
							- R — Function reserved.
							O LCD_VD15 — LCD data.
P3_2	F11	G6	116	166	OL; PU	I/O	I2S0_TX_SDA — I ² S transmit data. It is driven by the transmitter and read by the receiver. Corresponds to the signal SD in the I ² S-bus specification.
							I/O I2S0_RX_SDA — I ² S Receive data. It is driven by the transmitter and read by the receiver. Corresponds to the signal SD in the I ² S-bus specification.
							O CAN0_TD — CAN transmitter output.
							O USB1_IND0 — USB1 Port indicator LED control output 0.
							I/O GPIO5[9] — General purpose digital input/output pin.
							- R — Function reserved.
							O LCD_VD14 — LCD data.
- R — Function reserved.							

Table 170. LPC18xx Pin description (flash-based parts) ...continued

Pin name	LPGA256	TFBGA100	LQFP144	LQFP208	Reset state	Type	Description
P3_3	B14	A7	118	169	N; PU	-	R — Function reserved.
						-	R — Function reserved.
						I/O	SSP0_SCK — Serial clock for SSP0.
						O	SPIFI_SCK — Serial clock for SPIFI.
						O	CGU_OUT1 — CGU spare clock output 1.
						-	R — Function reserved.
						O	I2S0_TX_MCLK — I ² S transmit master clock.
P3_4	A15	B8	119	171	N; PU	I/O	GPIO1[14] — General purpose digital input/output pin.
						-	R — Function reserved.
						-	R — Function reserved.
						I/O	SPIFI_SIO3 — I/O lane 3 for SPIFI.
						O	U1_TXD — Transmitter output for UART1.
						I/O	I2S0_TX_WS — Transmit Word Select. It is driven by the master and received by the slave. Corresponds to the signal WS in the I ² S-bus specification.
						I/O	I2S1_RX_SDA — I ² S1 Receive data. It is driven by the transmitter and read by the receiver. Corresponds to the signal SD in the I ² S-bus specification.
P3_5	C12	B7	121	173	N; PU	O	LCD_VD13 — LCD data.
						I/O	GPIO1[15] — General purpose digital input/output pin.
						-	R — Function reserved.
						-	R — Function reserved.
						I/O	SPIFI_SIO2 — I/O lane 2 for SPIFI.
						I	U1_RXD — Receiver input for UART1.
						I/O	I2S0_TX_SDA — I ² S transmit data. It is driven by the transmitter and read by the receiver. Corresponds to the signal SD in the I ² S-bus specification.
P3_5	C12	B7	121	173	N; PU	I/O	I2S1_RX_WS — Receive Word Select. It is driven by the master and received by the slave. Corresponds to the signal WS in the I ² S-bus specification.
						O	LCD_VD12 — LCD data.

Table 170. LPC18xx Pin description (flash-based parts) ...continued

Pin name	LPGA256	TFBGA100	LQFP144	LQFP208	Reset state	Type	Description
P3_6	B13	C7	122	174	N; PU	I/O	GPIO0[6] — General purpose digital input/output pin.
						-	R — Function reserved.
						I/O	SSP0_SSEL — Slave Select for SSP0.
						I/O	SPIFI_MISO — Input 1 in SPIFI quad mode; SPIFI output IO1.
						-	R — Function reserved.
						I/O	SSP0_MISO — Master In Slave Out for SSP0.
						-	R — Function reserved.
P3_7	C11	D7	123	176	N; PU	-	R — Function reserved.
						-	R — Function reserved.
						I/O	SSP0_MISO — Master In Slave Out for SSP0.
						I/O	SPIFI_MOSI — Input 0 in SPIFI quad mode; SPIFI output IO0.
						I/O	GPIO5[10] — General purpose digital input/output pin.
						I/O	SSP0_MOSI — Master Out Slave in for SSP0.
						-	R — Function reserved.
P3_8	C10	E7	124	179	N; PU	-	R — Function reserved.
						-	R — Function reserved.
						I/O	SSP0_MOSI — Master Out Slave in for SSP0.
						I/O	SPIFI_CS — SPIFI serial flash chip select.
						I/O	GPIO5[11] — General purpose digital input/output pin.
						I/O	SSP0_SSEL — Slave Select for SSP0.
						-	R — Function reserved.
P4_0	D5	-	1	1	N; PU	I/O	GPIO2[0] — General purpose digital input/output pin.
						O	MCOA0 — Motor control PWM channel 0, output A.
						I	NMI — External interrupt input to NMI.
						-	R — Function reserved.
						-	R — Function reserved.
						O	LCD_VD13 — LCD data.
						I/O	U3_UCLK — Serial clock input/output for USART3 in synchronous mode.
-	R — Function reserved.						

Table 170. LPC18xx Pin description (flash-based parts) ...continued

Pin name	LPGA256	TFBGA100	LQFP144	LQFP208	Reset state	Type	Description
P4_1	A1	-	3	3	[5] N; PU	[1]	I/O GPIO2[1] — General purpose digital input/output pin.
							O CTOUT_1 — SCT output 1. Match output 3 of timer 3.
							O LCD_VD0 — LCD data.
							- R — Function reserved.
							- R — Function reserved.
							O LCD_VD19 — LCD data.
							O U3_TXD — Transmitter output for USART3.
							I ENET_COL — Ethernet Collision detect (MII interface).
							AI ADC0_1 — ADC0 and ADC1, input channel 1. Configure the pin as GPIO input and use the ADC function select register in the SCU to select the ADC.
							P4_2
O CTOUT_0 — SCT output 0. Match output 0 of timer 0.							
O LCD_VD3 — LCD data.							
- R — Function reserved.							
- R — Function reserved.							
O LCD_VD12 — LCD data.							
I U3_RXD — Receiver input for USART3.							
P4_3	C2	-	7	10	[5] N; PU		I/O GPIO2[3] — General purpose digital input/output pin.
							O CTOUT_3 — SCT output 3. Match output 3 of timer 0.
							O LCD_VD2 — LCD data.
							- R — Function reserved.
							- R — Function reserved.
							O LCD_VD21 — LCD data.
							I/O U3_BAUD — Baud pin for USART3.
							- R — Function reserved.
							AI ADC0_0 — DAC output, ADC0 and ADC1, input channel 0. Configure the pin as GPIO input and use the ADC function select register in the SCU to select the ADC.

Table 170. LPC18xx Pin description (flash-based parts) ...continued

Pin name	LPGA256	TFBGA100	LQFP144	LQFP208	Reset state	Type	Description
P4_4	B1	-	9	14	[5] N; PU	[1] I/O	GPIO2[4] — General purpose digital input/output pin.
							O CTOUT_2 — SCT output 2. Match output 2 of timer 0.
							O LCD_VD1 — LCD data.
							- R — Function reserved.
							- R — Function reserved.
							O LCD_VD20 — LCD data.
							I/O U3_DIR — RS-485/EIA-485 output enable/direction control for USART3.
							- R — Function reserved.
							AO DAC — DAC output. Shared between 10-bit ADC0/1 and DAC. Configure the pin as GPIO input and use the analog function select register in the SCU to select the DAC.
							P4_5
O CTOUT_5 — SCT output 5. Match output 3 of timer 3.							
O LCD_FP — Frame pulse (STN). Vertical synchronization pulse (TFT).							
- R — Function reserved.							
- R — Function reserved.							
- R — Function reserved.							
- R — Function reserved.							
P4_6	C1	-	11	17	[2] N; PU	I/O	GPIO2[6] — General purpose digital input/output pin.
							O CTOUT_4 — SCT output 4. Match output 3 of timer 3.
							O LCD_ENAB/LCDM — STN AC bias drive or TFT data enable input.
							- R — Function reserved.
							- R — Function reserved.
							- R — Function reserved.
							- R — Function reserved.

Table 170. LPC18xx Pin description (flash-based parts) ...continued

Pin name	LBGA256	TFBGA100	LQFP144	LQFP208	Reset state	Type	Description
P4_7	H4	-	14	21	[2] O; PU	[1]	O LCD_DCLK — LCD panel clock.
						I	GP_CLKIN — General purpose clock input to the CGU.
						-	R — Function reserved.
						-	R — Function reserved.
						-	R — Function reserved.
						-	R — Function reserved.
P4_8	E2	-	15	23	[2] N; PU	-	R — Function reserved.
						I	CTIN_5 — SCT input 5. Capture input 2 of timer 2.
						O	LCD_VD9 — LCD data.
						-	R — Function reserved.
						I/O	GPIO5[12] — General purpose digital input/output pin.
						O	LCD_VD22 — LCD data.
						O	CAN1_TD — CAN1 transmitter output.
						-	R — Function reserved.
P4_9	L2	-	33	48	[2] N; PU	-	R — Function reserved.
						I	CTIN_6 — SCT input 6. Capture input 1 of timer 3.
						O	LCD_VD11 — LCD data.
						-	R — Function reserved.
						I/O	GPIO5[13] — General purpose digital input/output pin.
						O	LCD_VD15 — LCD data.
P4_10	M3	-	35	51	[2] N; PU	-	R — Function reserved.
						I	CTIN_2 — SCT input 2. Capture input 2 of timer 0.
						O	LCD_VD10 — LCD data.
						-	R — Function reserved.
						I/O	GPIO5[14] — General purpose digital input/output pin.
						O	LCD_VD14 — LCD data.
-	R — Function reserved.						
-	R — Function reserved.						

Table 170. LPC18xx Pin description (flash-based parts) ...continued

Pin name	LBGA256	TFBGA100	LQFP144	LQFP208	Reset state [1]	Type	Description
P5_0	N3	-	37	53	[2] N; PU	I/O	GPIO2[9] — General purpose digital input/output pin.
						O	MCOB2 — Motor control PWM channel 2, output B.
						I/O	EMC_D12 — External memory data line 12.
						-	R — Function reserved.
						I	U1_DSR — Data Set Ready input for UART1.
						I	T1_CAP0 — Capture input 0 of timer 1.
						-	R — Function reserved.
P5_1	P3	-	39	55	[2] N; PU	I/O	GPIO2[10] — General purpose digital input/output pin.
						I	MCI2 — Motor control PWM channel 2, input.
						I/O	EMC_D13 — External memory data line 13.
						-	R — Function reserved.
						O	U1_DTR — Data Terminal Ready output for UART1. Can also be configured to be an RS-485/EIA-485 output enable signal for UART1.
						I	T1_CAP1 — Capture input 1 of timer 1.
						-	R — Function reserved.
P5_2	R4	-	46	63	[2] N; PU	I/O	GPIO2[11] — General purpose digital input/output pin.
						I	MCI1 — Motor control PWM channel 1, input.
						I/O	EMC_D14 — External memory data line 14.
						-	R — Function reserved.
						O	U1_RTS — Request to Send output for UART1. Can also be configured to be an RS-485/EIA-485 output enable signal for UART1.
						I	T1_CAP2 — Capture input 2 of timer 1.
						-	R — Function reserved.
P5_3	T8	-	54	76	[2] N; PU	I/O	GPIO2[12] — General purpose digital input/output pin.
						I	MCI0 — Motor control PWM channel 0, input.
						I/O	EMC_D15 — External memory data line 15.
						-	R — Function reserved.
						I	U1_RI — Ring Indicator input for UART1.
						I	T1_CAP3 — Capture input 3 of timer 1.
						-	R — Function reserved.

Table 170. LPC18xx Pin description (flash-based parts) ...continued

Pin name	LPGA256	TFBGA100	LQFP144	LQFP208	Reset state	Type	Description
P5_4	P9	-	57	80	N; PU	I/O	GPIO2[13] — General purpose digital input/output pin.
							O MCOB0 — Motor control PWM channel 0, output B.
							I/O EMC_D8 — External memory data line 8.
							- R — Function reserved.
							I U1_CTS — Clear to Send input for UART1.
							O T1_MAT0 — Match output 0 of timer 1.
							- R — Function reserved.
							- R — Function reserved.
P5_5	P10	-	58	81	N; PU	I/O	GPIO2[14] — General purpose digital input/output pin.
							O MCOA1 — Motor control PWM channel 1, output A.
							I/O EMC_D9 — External memory data line 9.
							- R — Function reserved.
							I U1_DCD — Data Carrier Detect input for UART1.
							O T1_MAT1 — Match output 1 of timer 1.
							- R — Function reserved.
							- R — Function reserved.
P5_6	T13	-	63	89	N; PU	I/O	GPIO2[15] — General purpose digital input/output pin.
							O MCOB1 — Motor control PWM channel 1, output B.
							I/O EMC_D10 — External memory data line 10.
							- R — Function reserved.
							O U1_TXD — Transmitter output for UART1.
							O T1_MAT2 — Match output 2 of timer 1.
							- R — Function reserved.
							- R — Function reserved.
P5_7	R12	-	65	91	N; PU	I/O	GPIO2[7] — General purpose digital input/output pin.
							O MCOA2 — Motor control PWM channel 2, output A.
							I/O EMC_D11 — External memory data line 11.
							- R — Function reserved.
							I U1_RXD — Receiver input for UART1.
							O T1_MAT3 — Match output 3 of timer 1.
							- R — Function reserved.
							- R — Function reserved.

Table 170. LPC18xx Pin description (flash-based parts) ...continued

Pin name	LBGA256	TFBGA100	LQFP144	LQFP208	Reset state [1]	Type	Description
P6_0	M12	H7	73	105	[2] N; PU	-	R — Function reserved.
						O	I2S0_RX_MCLK — I2S receive master clock.
						-	R — Function reserved.
						-	R — Function reserved.
						I/O	I2S0_RX_SCK — Receive Clock. It is driven by the master and received by the slave. Corresponds to the signal SCK in the <i>I2S-bus specification</i> .
						-	R — Function reserved.
						-	R — Function reserved.
P6_1	R15	G5	74	107	[2] N; PU	I/O	GPIO3[0] — General purpose digital input/output pin.
						O	EMC_DYCS1 — SDRAM chip select 1.
						I/O	U0_UCLK — Serial clock input/output for USART0 in synchronous mode.
						I/O	I2S0_RX_WS — Receive Word Select. It is driven by the master and received by the slave. Corresponds to the signal WS in the <i>I2S-bus specification</i> .
						-	R — Function reserved.
						I	T2_CAP0 — Capture input 0 of timer 2.
						-	R — Function reserved.
P6_2	L13	J9	78	111	[2] N; PU	I/O	GPIO3[1] — General purpose digital input/output pin.
						O	EMC_CKEOUT1 — SDRAM clock enable 1.
						I/O	U0_DIR — RS-485/EIA-485 output enable/direction control for USART0.
						I/O	I2S0_RX_SDA — I2S Receive data. It is driven by the transmitter and read by the receiver. Corresponds to the signal SD in the <i>I2S-bus specification</i> .
						-	R — Function reserved.
						I	T2_CAP1 — Capture input 1 of timer 2.
						-	R — Function reserved.

Table 170. LPC18xx Pin description (flash-based parts) ...continued

Pin name	LPGA256	TFBGA100	LQFP144	LQFP208	Reset state	Type	Description
P6_3	P15	-	79	113	N; PU	I/O	2 GPIO3[2] — General purpose digital input/output pin.
							O USB0_PPWR — VBUS drive signal (towards external charge pump or power management unit); indicates that VBUS must be driven (active HIGH). Add a pull-down resistor to disable the power switch at reset. This signal has opposite polarity compared to the USB_PPWR used on other NXP LPC parts.
							- R — Function reserved.
							O EMC_CS1 — LOW active Chip Select 1 signal.
							- R — Function reserved.
							I T2_CAP2 — Capture input 2 of timer 2.
P6_4	R16	F6	80	114	N; PU	I/O	2 GPIO3[3] — General purpose digital input/output pin.
							I CTIN_6 — SCT input 6. Capture input 1 of timer 3.
							O U0_TXD — Transmitter output for USART0.
							O EMC_CAS — LOW active SDRAM Column Address Strobe.
							- R — Function reserved.
							- R — Function reserved.
P6_5	P16	F9	82	117	N; PU	I/O	2 GPIO3[4] — General purpose digital input/output pin.
							O CTOUT_6 — SCT output 6. Match output 2 of timer 1.
							I U0_RXD — Receiver input for USART0.
							O EMC_RAS — LOW active SDRAM Row Address Strobe.
							- R — Function reserved.
							- R — Function reserved.
P6_6	L14	-	83	119	N; PU	I/O	2 GPIO0[5] — General purpose digital input/output pin.
							O EMC_BLS1 — LOW active Byte Lane select signal 1.
							- R — Function reserved.
							I USB0_PWR_FAULT — Port power fault signal indicating overcurrent condition; this signal monitors over-current on the USB bus (external circuitry required to detect over-current condition).
							- R — Function reserved.
							I T2_CAP3 — Capture input 3 of timer 2.
- R — Function reserved.							
- R — Function reserved.							

Table 170. LPC18xx Pin description (flash-based parts) ...continued

Pin name	LBGA256	TFBGA100	LQFP144	LQFP208	Reset state [1]	Type	Description
P6_7	J13	-	85	123	[2] N; PU	-	R — Function reserved.
						I/O	EMC_A15 — External memory address line 15.
						-	R — Function reserved.
						O	USB0_IND1 — USB0 port indicator LED control output 1.
						I/O	GPIO5[15] — General purpose digital input/output pin.
						O	T2_MAT0 — Match output 0 of timer 2.
						-	R — Function reserved.
P6_8	H13	-	86	125	[2] N; PU	-	R — Function reserved.
						I/O	EMC_A14 — External memory address line 14.
						-	R — Function reserved.
						O	USB0_IND0 — USB0 port indicator LED control output 0.
						I/O	GPIO5[16] — General purpose digital input/output pin.
						O	T2_MAT1 — Match output 1 of timer 2.
						-	R — Function reserved.
P6_9	J15	F8	97	139	[2] N; PU	I/O	GPIO3[5] — General purpose digital input/output pin.
						-	R — Function reserved.
						-	R — Function reserved.
						O	EMC_DYCS0 — SDRAM chip select 0.
						-	R — Function reserved.
						O	T2_MAT2 — Match output 2 of timer 2.
						-	R — Function reserved.
P6_10	H15	-	100	142	[2] N; PU	I/O	GPIO3[6] — General purpose digital input/output pin.
						O	MCABORT — Motor control PWM, LOW-active fast abort.
						-	R — Function reserved.
						O	EMC_DQMOUT1 — Data mask 1 used with SDRAM and static devices.
						-	R — Function reserved.
						-	R — Function reserved.
						-	R — Function reserved.

Table 170. LPC18xx Pin description (flash-based parts) ...continued

Pin name	LPGA256	TFBGA100	LQFP144	LQFP208	Reset state	Type	Description
P6_11	H12	C9	101	143	N; PU	I/O	GPIO3[7] — General purpose digital input/output pin.
							- R — Function reserved.
							- R — Function reserved.
							O EMC_CKEOUT0 — SDRAM clock enable 0.
							- R — Function reserved.
							O T2_MAT3 — Match output 3 of timer 2.
							- R — Function reserved.
- R — Function reserved.							
P6_12	G15	-	103	145	N; PU	I/O	GPIO2[8] — General purpose digital input/output pin.
							O CTOUT_7 — SCT output 7. Match output 3 of timer 1.
							- R — Function reserved.
							O EMC_DQMOUT0 — Data mask 0 used with SDRAM and static devices.
							- R — Function reserved.
- R — Function reserved.							
P7_0	B16	-	110	158	N; PU	I/O	GPIO3[8] — General purpose digital input/output pin.
							O CTOUT_14 — SCT output 14. Match output 2 of timer 3.
							- R — Function reserved.
							O LCD_LE — Line end signal.
							- R — Function reserved.
							- R — Function reserved.
							- R — Function reserved.
- R — Function reserved.							
P7_1	C14	-	113	162	N; PU	I/O	GPIO3[9] — General purpose digital input/output pin.
							O CTOUT_15 — SCT output 15. Match output 3 of timer 3.
							I/O I2S0_TX_WS — Transmit Word Select. It is driven by the master and received by the slave. Corresponds to the signal <i>WS</i> in the <i>I²S-bus specification</i> .
							O LCD_VD19 — LCD data.
							O LCD_VD7 — LCD data.
							- R — Function reserved.
							O U2_TXD — Transmitter output for USART2.
							- R — Function reserved.

Table 170. LPC18xx Pin description (flash-based parts) ...continued

Pin name	LBGA256	TFBGA100	LQFP144	LQFP208	Reset state [1]	Type	Description
P7_2	A16	-	115	165	[2] N; PU	I/O	GPIO3[10] — General purpose digital input/output pin.
						I	CTIN_4 — SCT input 4. Capture input 2 of timer 1.
						I/O	I2S0_TX_SDA — I ² S transmit data. It is driven by the transmitter and read by the receiver. Corresponds to the signal SD in the <i>I²S-bus specification</i> .
						O	LCD_VD18 — LCD data.
						O	LCD_VD6 — LCD data.
						-	R — Function reserved.
						I	U2_RXD — Receiver input for USART2.
P7_3	C13	-	117	167	[2] N; PU	I/O	GPIO3[11] — General purpose digital input/output pin.
						I	CTIN_3 — SCT input 3. Capture input 1 of timer 1.
						-	R — Function reserved.
						O	LCD_VD17 — LCD data.
						O	LCD_VD5 — LCD data.
						-	R — Function reserved.
						-	R — Function reserved.
P7_4	C8	-	132	189	[5] N; PU	I/O	GPIO3[12] — General purpose digital input/output pin.
						O	CTOUT_13 — SCT output 13. Match output 3 of timer 3.
						-	R — Function reserved.
						O	LCD_VD16 — LCD data.
						O	LCD_VD4 — LCD data.
						O	TRACEDATA[0] — Trace data, bit 0.
						-	R — Function reserved.
AI	ADC0_4 — ADC0 and ADC1, input channel 4. Configure the pin as GPIO input and use the ADC function select register in the SCU to select the ADC.						

Table 170. LPC18xx Pin description (flash-based parts) ...continued

Pin name	LPGA256	TFBGA100	LQFP144	LQFP208	Reset state	Type	Description
P7_5	A7	-	133	191	[5] N; PU	[1] I/O	GPIO3[13] — General purpose digital input/output pin.
						O	CTOUT_12 — SCT output 12. Match output 3 of timer 3.
						-	R — Function reserved.
						O	LCD_VD8 — LCD data.
						O	LCD_VD23 — LCD data.
						O	TRACEDATA[1] — Trace data, bit 1.
						-	R — Function reserved.
						-	R — Function reserved.
P7_6	C7	-	134	194	[2] N; PU	I/O	GPIO3[14] — General purpose digital input/output pin.
						O	CTOUT_11 — SCT output 1. Match output 3 of timer 2.
						-	R — Function reserved.
						O	LCD_LP — Line synchronization pulse (STN). Horizontal synchronization pulse (TFT).
						-	R — Function reserved.
						O	TRACEDATA[2] — Trace data, bit 2.
						-	R — Function reserved.
						-	R — Function reserved.
P7_7	B6	-	140	201	[5] N; PU	I/O	GPIO3[15] — General purpose digital input/output pin.
						O	CTOUT_8 — SCT output 8. Match output 0 of timer 2.
						-	R — Function reserved.
						O	LCD_PWR — LCD panel power enable.
						-	R — Function reserved.
						O	TRACEDATA[3] — Trace data, bit 3.
						O	ENET_MDC — Ethernet MIIM clock.
						-	R — Function reserved.
AI	ADC1_6 — ADC1 and ADC0, input channel 6. Configure the pin as GPIO input and use the ADC function select register in the SCU to select the ADC.						

Table 170. LPC18xx Pin description (flash-based parts) ...continued

Pin name	LPGA256	TFBGA100	LQFP144	LQFP208	Reset state	Type	Description
P8_0	E5	-	-	2	N; PU	I/O	[3] GPIO4[0] — General purpose digital input/output pin.
							I USB0_PWR_FAULT — Port power fault signal indicating overcurrent condition; this signal monitors over-current on the USB bus (external circuitry required to detect over-current condition).
							- R — Function reserved.
							I MCI2 — Motor control PWM channel 2, input.
							- R — Function reserved.
							- R — Function reserved.
							- R — Function reserved.
P8_1	H5	-	-	34	N; PU	I/O	[3] GPIO4[1] — General purpose digital input/output pin.
							O USB0_IND1 — USB0 port indicator LED control output 1.
							- R — Function reserved.
							I MCI1 — Motor control PWM channel 1, input.
							- R — Function reserved.
							- R — Function reserved.
							- R — Function reserved.
P8_2	K4	-	-	36	N; PU	I/O	[3] GPIO4[2] — General purpose digital input/output pin.
							O USB0_IND0 — USB0 port indicator LED control output 0.
							- R — Function reserved.
							I MCI0 — Motor control PWM channel 0, input.
							- R — Function reserved.
							- R — Function reserved.
							- R — Function reserved.
P8_3	J3	-	-	37	N; PU	I/O	[2] GPIO4[3] — General purpose digital input/output pin.
							I/O USB1_ULPI_D2 — ULPI link bidirectional data line 2.
							- R — Function reserved.
							O LCD_VD12 — LCD data.
							O LCD_VD19 — LCD data.
							- R — Function reserved.
							- R — Function reserved.
O TO_MAT3 — Match output 3 of timer 0.							

Table 170. LPC18xx Pin description (flash-based parts) ...continued

Pin name	LPGA256	TFBGA100	LQFP144	LQFP208	Reset state	Type	Description
P8_4	J2	-	-	39	N; PU	I/O	GPIO4[4] — General purpose digital input/output pin.
						I/O	USB1_ULPI_D1 — ULPI link bidirectional data line 1.
						-	R — Function reserved.
						O	LCD_VD7 — LCD data.
						O	LCD_VD16 — LCD data.
						-	R — Function reserved.
						-	R — Function reserved.
P8_5	J1	-	-	40	N; PU	I/O	GPIO4[5] — General purpose digital input/output pin.
						I/O	USB1_ULPI_D0 — ULPI link bidirectional data line 0.
						-	R — Function reserved.
						O	LCD_VD6 — LCD data.
						O	LCD_VD8 — LCD data.
						-	R — Function reserved.
						-	R — Function reserved.
P8_6	K3	-	-	43	N; PU	I/O	GPIO4[6] — General purpose digital input/output pin.
						I	USB1_ULPI_NXT — ULPI link NXT signal. Data flow control signal from the PHY.
						-	R — Function reserved.
						O	LCD_VD5 — LCD data.
						O	LCD_LP — Line synchronization pulse (STN). Horizontal synchronization pulse (TFT).
						-	R — Function reserved.
						-	R — Function reserved.
P8_7	K1	-	-	45	N; PU	I/O	GPIO4[7] — General purpose digital input/output pin.
						O	USB1_ULPI_STP — ULPI link STP signal. Asserted to end or interrupt transfers to the PHY.
						-	R — Function reserved.
						O	LCD_VD4 — LCD data.
						O	LCD_PWR — LCD panel power enable.
						-	R — Function reserved.
						-	R — Function reserved.
						I	T0_CAP3 — Capture input 3 of timer 0.

Table 170. LPC18xx Pin description (flash-based parts) ...continued

Pin name	LPGA256	TFBGA100	LQFP144	LQFP208	Reset state	Type	Description
P8_8	L1	-	-	49	N; PU	-	R — Function reserved.
						I	USB1_ULPI_CLK — ULPI link CLK signal. 60 MHz clock generated by the PHY.
						-	R — Function reserved.
						-	R — Function reserved.
						-	R — Function reserved.
						O	CGU_OUT0 — CGU spare clock output 0.
						O	I2S1_TX_MCLK — I2S1 transmit master clock.
P9_0	T1	-	-	59	N; PU	I/O	GPIO4[12] — General purpose digital input/output pin.
						O	MCABORT — Motor control PWM, LOW-active fast abort.
						-	R — Function reserved.
						-	R — Function reserved.
						-	R — Function reserved.
						I	ENET_CRS — Ethernet Carrier Sense (MII interface).
						-	R — Function reserved.
						I/O	SSP0_SSEL — Slave Select for SSP0.
P9_1	N6	-	-	66	N; PU	I/O	GPIO4[13] — General purpose digital input/output pin.
						O	MCOA2 — Motor control PWM channel 2, output A.
						-	R — Function reserved.
						-	R — Function reserved.
						I/O	I2S0_TX_WS — Transmit Word Select. It is driven by the master and received by the slave. Corresponds to the signal WS in the I2S-bus specification.
						I	ENET_RX_ER — Ethernet receive error (MII interface).
						-	R — Function reserved.
						I/O	SSP0_MISO — Master In Slave Out for SSP0.
P9_2	N8	-	-	70	N; PU	I/O	GPIO4[14] — General purpose digital input/output pin.
						O	MCOB2 — Motor control PWM channel 2, output B.
						-	R — Function reserved.
						-	R — Function reserved.
						I/O	I2S0_TX_SDA — I2S transmit data. It is driven by the transmitter and read by the receiver. Corresponds to the signal SD in the I2S-bus specification.
						I	ENET_RXD3 — Ethernet receive data 3 (MII interface).
						-	R — Function reserved.
						I/O	SSP0_MOSI — Master Out Slave in for SSP0.

Table 170. LPC18xx Pin description (flash-based parts) ...continued

Pin name	LPGA256	TFBGA100	LQFP144	LQFP208	Reset state	Type	Description
P9_3	M6	-	-	79	N; PU	I/O	GPIO4[15] — General purpose digital input/output pin.
						O	MCOA0 — Motor control PWM channel 0, output A.
						O	USB1_IND1 — USB1 Port indicator LED control output 1.
						-	R — Function reserved.
						-	R — Function reserved.
						I	ENET_RXD2 — Ethernet receive data 2 (MII interface).
						-	R — Function reserved.
P9_4	N10	-	-	92	N; PU	-	R — Function reserved.
						O	MCOB0 — Motor control PWM channel 0, output B.
						O	USB1_IND0 — USB1 Port indicator LED control output 0.
						-	R — Function reserved.
						I/O	GPIO5[17] — General purpose digital input/output pin.
						O	ENET_TXD2 — Ethernet transmit data 2 (MII interface).
						-	R — Function reserved.
P9_5	M9	-	69	98	N; PU	I	U3_RXD — Receiver input for USART3.
						-	R — Function reserved.
						O	MCOA1 — Motor control PWM channel 1, output A.
						O	USB1_PPWR — VBUS drive signal (towards external charge pump or power management unit); indicates that VBUS must be driven (active HIGH). Add a pull-down resistor to disable the power switch at reset. This signal has opposite polarity compared to the USB_PPWR used on other NXP LPC parts.
						-	R — Function reserved.
						I/O	GPIO5[18] — General purpose digital input/output pin.
						O	ENET_TXD3 — Ethernet transmit data 3 (MII interface).
P9_6	L11	-	72	103	N; PU	O	U0_TXD — Transmitter output for USART0.
						I/O	GPIO4[11] — General purpose digital input/output pin.
						O	MCOB1 — Motor control PWM channel 1, output B.
						I	USB1_PWR_FAULT — USB1 Port power fault signal indicating over-current condition; this signal monitors over-current on the USB1 bus (external circuitry required to detect over-current condition).
						-	R — Function reserved.
						-	R — Function reserved.
						I	ENET_COL — Ethernet Collision detect (MII interface).
-	R — Function reserved.						
I	U0_RXD — Receiver input for USART0.						

Table 170. LPC18xx Pin description (flash-based parts) ...continued

Pin name	LPGA256	TFBGA100	LQFP144	LQFP208	Reset state	Type	Description
PA_0	L12	-	-	126	N; PU	[2]	- R — Function reserved.
							- R — Function reserved.
							- R — Function reserved.
							- R — Function reserved.
							- R — Function reserved.
							O I2S1_RX_MCLK — I2S1 receive master clock.
							O CGU_OUT1 — CGU spare clock output 1.
							- R — Function reserved.
PA_1	J14	-	-	134	N; PU	[3]	I/O GPIO4[8] — General purpose digital input/output pin.
							I QEI_IDX — Quadrature Encoder Interface INDEX input.
							- R — Function reserved.
							O U2_TXD — Transmitter output for USART2.
							- R — Function reserved.
							- R — Function reserved.
							- R — Function reserved.
							- R — Function reserved.
PA_2	K15	-	-	136	N; PU	[3]	I/O GPIO4[9] — General purpose digital input/output pin.
							I QEI_PHB — Quadrature Encoder Interface PHB input.
							- R — Function reserved.
							I U2_RXD — Receiver input for USART2.
							- R — Function reserved.
							- R — Function reserved.
							- R — Function reserved.
							- R — Function reserved.
PA_3	H11	-	-	147	N; PU	[3]	I/O GPIO4[10] — General purpose digital input/output pin.
							I QEI_PHA — Quadrature Encoder Interface PHA input.
							- R — Function reserved.
							- R — Function reserved.
							- R — Function reserved.
							- R — Function reserved.
							- R — Function reserved.
							- R — Function reserved.

Table 170. LPC18xx Pin description (flash-based parts) ...continued

Pin name	LPGA256	TFBGA100	LQFP144	LQFP208	Reset state	Type	Description
PA_4	G13	-	-	151	N; PU	-	R — Function reserved.
						O	CTOUT_9 — SCT output 9. Match output 3 of timer 3.
						-	R — Function reserved.
						I/O	EMC_A23 — External memory address line 23.
						I/O	GPIO5[19] — General purpose digital input/output pin.
						-	R — Function reserved.
						-	R — Function reserved.
PB_0	B15	-	-	164	N; PU	-	R — Function reserved.
						O	CTOUT_10 — SCT output 10. Match output 3 of timer 3.
						O	LCD_VD23 — LCD data.
						-	R — Function reserved.
						I/O	GPIO5[20] — General purpose digital input/output pin.
						-	R — Function reserved.
						-	R — Function reserved.
PB_1	A14	-	-	175	N; PU	-	R — Function reserved.
						I	USB1_ULPI_DIR — ULPI link DIR signal. Controls the ULP data line direction.
						O	LCD_VD22 — LCD data.
						-	R — Function reserved.
						I/O	GPIO5[21] — General purpose digital input/output pin.
						O	CTOUT_6 — SCT output 6. Match output 2 of timer 1.
						-	R — Function reserved.
PB_2	B12	-	-	177	N; PU	-	R — Function reserved.
						I/O	USB1_ULPI_D7 — ULPI link bidirectional data line 7.
						O	LCD_VD21 — LCD data.
						-	R — Function reserved.
						I/O	GPIO5[22] — General purpose digital input/output pin.
						O	CTOUT_7 — SCT output 7. Match output 3 of timer 1.
						-	R — Function reserved.
-	R — Function reserved.						

Table 170. LPC18xx Pin description (flash-based parts) ...continued

Pin name	LPGA256	TFBGA100	LQFP144	LQFP208	Reset state	Type	Description
PB_3	A13	-	-	178	N; PU	-	R — Function reserved.
						I/O	USB1_ULPI_D6 — ULPI link bidirectional data line 6.
						O	LCD_VD20 — LCD data.
						-	R — Function reserved.
						I/O	GPIO5[23] — General purpose digital input/output pin.
						O	CTOUT_8 — SCT output 8. Match output 0 of timer 2.
						-	R — Function reserved.
PB_4	B11	-	-	180	N; PU	-	R — Function reserved.
						I/O	USB1_ULPI_D5 — ULPI link bidirectional data line 5.
						O	LCD_VD15 — LCD data.
						-	R — Function reserved.
						I/O	GPIO5[24] — General purpose digital input/output pin.
						I	CTIN_5 — SCT input 5. Capture input 2 of timer 2.
						-	R — Function reserved.
PB_5	A12	-	-	181	N; PU	-	R — Function reserved.
						I/O	USB1_ULPI_D4 — ULPI link bidirectional data line 4.
						O	LCD_VD14 — LCD data.
						-	R — Function reserved.
						I/O	GPIO5[25] — General purpose digital input/output pin.
						I	CTIN_7 — SCT input 7.
						O	LCD_PWR — LCD panel power enable.
PB_6	A6	-	-	-	N; PU	-	R — Function reserved.
						I/O	USB1_ULPI_D3 — ULPI link bidirectional data line 3.
						O	LCD_VD13 — LCD data.
						-	R — Function reserved.
						I/O	GPIO5[26] — General purpose digital input/output pin.
						I	CTIN_6 — SCT input 6. Capture input 1 of timer 3.
						O	LCD_VD19 — LCD data.
-	R — Function reserved.						
						AI	ADC0_6 — ADC0 and ADC1, input channel 6. Configure the pin as GPIO input and use the ADC function select register in the SCU to select the ADC.

Table 170. LPC18xx Pin description (flash-based parts) ...continued

Pin name	LPGA256	TFBGA100	LQFP144	LQFP208	Reset state	Type	Description
PC_0	D4	-	-	7	[5] N; PU	-	R — Function reserved.
						I	USB1_ULPI_CLK — ULPI link CLK signal. 60 MHz clock generated by the PHY.
						-	R — Function reserved.
						I/O	ENET_RX_CLK — Ethernet Receive Clock (MII interface).
						O	LCD_DCLK — LCD panel clock.
						-	R — Function reserved.
						-	R — Function reserved.
						I/O	SD_CLK — SD/MMC card clock.
PC_1	E4	-	-	9	[2] N; PU	I/O	USB1_ULPI_D7 — ULPI link bidirectional data line 7.
						-	R — Function reserved.
						I	U1_RI — Ring Indicator input for UART1.
						O	ENET_MDC — Ethernet MIIM clock.
						I/O	GPIO6[0] — General purpose digital input/output pin.
						-	R — Function reserved.
						I	T3_CAP0 — Capture input 0 of timer 3.
						O	SD_VOLT0 — SD/MMC bus voltage select output 0.
PC_2	F6	-	-	13	[2] N; PU	I/O	USB1_ULPI_D6 — ULPI link bidirectional data line 6.
						-	R — Function reserved.
						I	U1_CTS — Clear to Send input for UART1.
						O	ENET_TXD2 — Ethernet transmit data 2 (MII interface).
						I/O	GPIO6[1] — General purpose digital input/output pin.
						-	R — Function reserved.
						-	R — Function reserved.
						O	SD_RST — SD/MMC reset signal for MMC4.4 card.

Table 170. LPC18xx Pin description (flash-based parts) ...continued

Pin name	LPGA256	TFBGA100	LQFP144	LQFP208	Reset state	Type	Description
PC_3	F5	-	-	11	[5] N; PU	I/O	USB1_ULPI_D5 — ULPI link bidirectional data line 5.
						-	R — Function reserved.
						O	U1_RTS — Request to Send output for UART1. Can also be configured to be an RS-485/EIA-485 output enable signal for UART1.
						O	ENET_TXD3 — Ethernet transmit data 3 (MII interface).
						I/O	GPIO6[2] — General purpose digital input/output pin.
						-	R — Function reserved.
						-	R — Function reserved.
PC_4	F4	-	-	16	[2] N; PU	-	R — Function reserved.
						I/O	USB1_ULPI_D4 — ULPI link bidirectional data line 4.
						-	R — Function reserved.
							ENET_TX_EN — Ethernet transmit enable (RMII/MII interface).
						I/O	GPIO6[3] — General purpose digital input/output pin.
						-	R — Function reserved.
						I	T3_CAP1 — Capture input 1 of timer 3.
PC_5	G4	-	-	20	[2] N; PU	-	R — Function reserved.
						I/O	USB1_ULPI_D3 — ULPI link bidirectional data line 3.
						-	R — Function reserved.
						O	ENET_TX_ER — Ethernet Transmit Error (MII interface).
						I/O	GPIO6[4] — General purpose digital input/output pin.
						-	R — Function reserved.
						I	T3_CAP2 — Capture input 2 of timer 3.
PC_6	H6	-	-	22	[2] N; PU	-	R — Function reserved.
						I/O	USB1_ULPI_D2 — ULPI link bidirectional data line 2.
						-	R — Function reserved.
						I	ENET_RXD2 — Ethernet receive data 2 (MII interface).
						I/O	GPIO6[5] — General purpose digital input/output pin.
						-	R — Function reserved.
						I	T3_CAP3 — Capture input 3 of timer 3.
	SD_DAT2 — SD/MMC data bus line 2.						

Table 170. LPC18xx Pin description (flash-based parts) ...continued

Pin name	LBGA256	TFBGA100	LQFP144	LQFP208	Reset state [1]	Type	Description
PC_7	G5	-	-	-	[2] N; PU	-	R — Function reserved.
						I/O	USB1_ULPI_D1 — ULPI link bidirectional data line 1.
						-	R — Function reserved.
						I	ENET_RXD3 — Ethernet receive data 3 (MII interface).
						I/O	GPIO6[6] — General purpose digital input/output pin.
						-	R — Function reserved.
						O	T3_MAT0 — Match output 0 of timer 3.
PC_8	N4	-	-	-	[2] N; PU	-	R — Function reserved.
						I/O	USB1_ULPI_D0 — ULPI link bidirectional data line 0.
						-	R — Function reserved.
						I	ENET_RX_DV — Ethernet Receive Data Valid (RMII/MII interface).
						I/O	GPIO6[7] — General purpose digital input/output pin.
						-	R — Function reserved.
						O	T3_MAT1 — Match output 1 of timer 3.
PC_9	K2	-	-	-	[2] N; PU	-	R — Function reserved.
						I	USB1_ULPI_NXT — ULPI link NXT signal. Data flow control signal from the PHY.
						-	R — Function reserved.
						I	ENET_RX_ER — Ethernet receive error (MII interface).
						I/O	GPIO6[8] — General purpose digital input/output pin.
						-	R — Function reserved.
						O	T3_MAT2 — Match output 2 of timer 3.
PC_10	M5	-	-	-	[2] N; PU	-	R — Function reserved.
						O	USB1_ULPI_STP — ULPI link STP signal. Asserted to end or interrupt transfers to the PHY.
						I	U1_DSR — Data Set Ready input for UART1.
						-	R — Function reserved.
						I/O	GPIO6[9] — General purpose digital input/output pin.
						-	R — Function reserved.
						O	T3_MAT3 — Match output 3 of timer 3.
I/O	SD_CMD — SD/MMC command signal.						

Table 170. LPC18xx Pin description (flash-based parts) ...continued

Pin name	LBGA256	TFBGA100	LQFP144	LQFP208	Reset state [2]	Type [1]	Description
							Description
PC_11	L5	-	-	-	N; PU	-	R — Function reserved.
						I	USB1_ULPI_DIR — ULPI link DIR signal. Controls the ULP data line direction.
						I	U1_DCD — Data Carrier Detect input for UART1.
						-	R — Function reserved.
						I/O	GPIO6[10] — General purpose digital input/output pin.
						-	R — Function reserved.
						-	R — Function reserved.
						I/O	SD_DAT4 — SD/MMC data bus line 4.
PC_12	L6	-	-	-	N; PU	-	R — Function reserved.
						-	R — Function reserved.
						O	U1_DTR — Data Terminal Ready output for UART1. Can also be configured to be an RS-485/EIA-485 output enable signal for UART1.
						-	R — Function reserved.
						I/O	GPIO6[11] — General purpose digital input/output pin.
						-	R — Function reserved.
						I/O	I2S0_TX_SDA — I ² S transmit data. It is driven by the transmitter and read by the receiver. Corresponds to the signal SD in the <i>I²S-bus specification</i> .
						I/O	SD_DAT5 — SD/MMC data bus line 5.
PC_13	M1	-	-	-	N; PU	-	R — Function reserved.
						-	R — Function reserved.
						O	U1_TXD — Transmitter output for UART1.
						-	R — Function reserved.
						I/O	GPIO6[12] — General purpose digital input/output pin.
						-	R — Function reserved.
						I/O	I2S0_TX_WS — Transmit Word Select. It is driven by the master and received by the slave. Corresponds to the signal WS in the <i>I²S-bus specification</i> .
						I/O	SD_DAT6 — SD/MMC data bus line 6.
PC_14	N1	-	-	-	N; PU	-	R — Function reserved.
						-	R — Function reserved.
						I	U1_RXD — Receiver input for UART1.
						-	R — Function reserved.
						I/O	GPIO6[13] — General purpose digital input/output pin.
						-	R — Function reserved.
						O	ENET_TX_ER — Ethernet Transmit Error (MII interface).
						I/O	SD_DAT7 — SD/MMC data bus line 7.

Table 170. LPC18xx Pin description (flash-based parts) ...continued

Pin name	LPGA256	TFBGA100	LQFP144	LQFP208	Reset state	Type	Description
PD_0	N2	-	-	-	N; PU	-	R — Function reserved.
						O	CTOUT_15 — SCT output 15. Match output 3 of timer 3.
						O	EMC_DQMOUT2 — Data mask 2 used with SDRAM and static devices.
						-	R — Function reserved.
						I/O	GPIO6[14] — General purpose digital input/output pin.
						-	R — Function reserved.
						-	R — Function reserved.
PD_1	P1	-	-	-	N; PU	-	R — Function reserved.
						-	R — Function reserved.
						O	EMC_CKEOUT2 — SDRAM clock enable 2.
						-	R — Function reserved.
						I/O	GPIO6[15] — General purpose digital input/output pin.
						O	SD_POW — SD/MMC power monitor output.
						-	R — Function reserved.
PD_2	R1	-	-	-	N; PU	-	R — Function reserved.
						O	CTOUT_7 — SCT output 7. Match output 3 of timer 1.
						I/O	EMC_D16 — External memory data line 16.
						-	R — Function reserved.
						I/O	GPIO6[16] — General purpose digital input/output pin.
						-	R — Function reserved.
						-	R — Function reserved.
PD_3	P4	-	-	-	N; PU	-	R — Function reserved.
						O	CTOUT_6 — SCT output 7. Match output 2 of timer 1.
						I/O	EMC_D17 — External memory data line 17.
						-	R — Function reserved.
						I/O	GPIO6[17] — General purpose digital input/output pin.
						-	R — Function reserved.
						-	R — Function reserved.

Table 170. LPC18xx Pin description (flash-based parts) ...continued

Pin name	LPGA256	TFBGA100	LQFP144	LQFP208	Reset state	Type	Description
PD_4	T2	-	-	-	N; PU	-	R — Function reserved.
						O	CTOUT_8 — SCT output 8. Match output 0 of timer 2.
						I/O	EMC_D18 — External memory data line 18.
						-	R — Function reserved.
						I/O	GPIO6[18] — General purpose digital input/output pin.
						-	R — Function reserved.
						-	R — Function reserved.
PD_5	P6	-	-	-	N; PU	-	R — Function reserved.
						O	CTOUT_9 — SCT output 9. Match output 3 of timer 3.
						I/O	EMC_D19 — External memory data line 19.
						-	R — Function reserved.
						I/O	GPIO6[19] — General purpose digital input/output pin.
						-	R — Function reserved.
						-	R — Function reserved.
PD_6	R6	-	-	68	N; PU	-	R — Function reserved.
						O	CTOUT_10 — SCT output 10. Match output 3 of timer 3.
						I/O	EMC_D20 — External memory data line 20.
						-	R — Function reserved.
						I/O	GPIO6[20] — General purpose digital input/output pin.
						-	R — Function reserved.
						-	R — Function reserved.
PD_7	T6	-	-	72	N; PU	-	R — Function reserved.
						I	CTIN_5 — SCT input 5. Capture input 2 of timer 2.
						I/O	EMC_D21 — External memory data line 21.
						-	R — Function reserved.
						I/O	GPIO6[21] — General purpose digital input/output pin.
						-	R — Function reserved.
						-	R — Function reserved.

Table 170. LPC18xx Pin description (flash-based parts) ...continued

Pin name	LPGA256	TFBGA100	LQFP144	LQFP208	Reset state	Type	Description
PD_8	P8	-	-	74	N; PU	-	R — Function reserved.
						I	CTIN_6 — SCT input 6. Capture input 1 of timer 3.
						I/O	EMC_D22 — External memory data line 22.
						-	R — Function reserved.
						I/O	GPIO6[22] — General purpose digital input/output pin.
						-	R — Function reserved.
						-	R — Function reserved.
PD_9	T11	-	-	84	N; PU	-	R — Function reserved.
						O	CTOUT_13 — SCT output 13. Match output 3 of timer 3.
						I/O	EMC_D23 — External memory data line 23.
						-	R — Function reserved.
						I/O	GPIO6[23] — General purpose digital input/output pin.
						-	R — Function reserved.
						-	R — Function reserved.
PD_10	P11	-	-	86	N; PU	-	R — Function reserved.
						I	CTIN_1 — SCT input 1. Capture input 1 of timer 0. Capture input 1 of timer 2.
						O	EMC_BLS3 — LOW active Byte Lane select signal 3.
						-	R — Function reserved.
						I/O	GPIO6[24] — General purpose digital input/output pin.
						-	R — Function reserved.
						-	R — Function reserved.
PD_11	N9	-	-	88	N; PU	-	R — Function reserved.
						-	R — Function reserved.
						O	EMC_CS3 — LOW active Chip Select 3 signal.
						-	R — Function reserved.
						I/O	GPIO6[25] — General purpose digital input/output pin.
						I/O	USB1_ULPI_D0 — ULPI link bidirectional data line 0.
						O	CTOUT_14 — SCT output 14. Match output 2 of timer 3.
-	R — Function reserved.						

Table 170. LPC18xx Pin description (flash-based parts) ...continued

Pin name	LPGA256	TFBGA100	LQFP144	LQFP208	Reset state	Type	Description
PD_12	N11	-	-	94	N; PU	-	R — Function reserved.
						-	R — Function reserved.
						O	EMC_CS2 — LOW active Chip Select 2 signal.
						-	R — Function reserved.
						I/O	GPIO6[26] — General purpose digital input/output pin.
						-	R — Function reserved.
						O	CTOUT_10 — SCT output 10. Match output 3 of timer 3.
PD_13	T14	-	-	97	N; PU	-	R — Function reserved.
						I	CTIN_0 — SCT input 0. Capture input 0 of timer 0, 1, 2, 3.
						O	EMC_BLS2 — LOW active Byte Lane select signal 2.
						-	R — Function reserved.
						I/O	GPIO6[27] — General purpose digital input/output pin.
						-	R — Function reserved.
						O	CTOUT_13 — SCT output 13. Match output 3 of timer 3.
PD_14	R13	-	-	99	N; PU	-	R — Function reserved.
						-	R — Function reserved.
						O	EMC_DYCS2 — SDRAM chip select 2.
						-	R — Function reserved.
						I/O	GPIO6[28] — General purpose digital input/output pin.
						-	R — Function reserved.
						O	CTOUT_11 — SCT output 11. Match output 3 of timer 2.
PD_15	T15	-	-	101	N; PU	-	R — Function reserved.
						-	R — Function reserved.
						I/O	EMC_A17 — External memory address line 17.
						-	R — Function reserved.
						I/O	GPIO6[29] — General purpose digital input/output pin.
						I	SD_WP — SD/MMC card write protect input.
						O	CTOUT_8 — SCT output 8. Match output 0 of timer 2.
-	R — Function reserved.						

Table 170. LPC18xx Pin description (flash-based parts) ...continued

Pin name	LPGA256	TFBGA100	LQFP144	LQFP208	Reset state	Type	Description
PD_16	R14	-	-	104	N; PU	-	R — Function reserved.
						-	R — Function reserved.
						I/O	EMC_A16 — External memory address line 16.
						-	R — Function reserved.
						I/O	GPIO6[30] — General purpose digital input/output pin.
						O	SD_VOLT2 — SD/MMC bus voltage select output 2.
						O	CTOUT_12 — SCT output 12. Match output 3 of timer 3.
						-	R — Function reserved.
PE_0	P14	-	-	106	N; PU	-	R — Function reserved.
						-	R — Function reserved.
						-	R — Function reserved.
						I/O	EMC_A18 — External memory address line 18.
						I/O	GPIO7[0] — General purpose digital input/output pin.
						O	CAN1_TD — CAN1 transmitter output.
						-	R — Function reserved.
						-	R — Function reserved.
PE_1	N14	-	-	112	N; PU	-	R — Function reserved.
						-	R — Function reserved.
						-	R — Function reserved.
						I/O	EMC_A19 — External memory address line 19.
						I/O	GPIO7[1] — General purpose digital input/output pin.
						I	CAN1_RD — CAN1 receiver input.
						-	R — Function reserved.
						-	R — Function reserved.
PE_2	M14	-	-	115	N; PU	I	ADCTRIG0 — ADC trigger input 0.
						I	CAN0_RD — CAN receiver input.
						-	R — Function reserved.
						I/O	EMC_A20 — External memory address line 20.
						I/O	GPIO7[2] — General purpose digital input/output pin.
						-	R — Function reserved.
						-	R — Function reserved.
						-	R — Function reserved.

Table 170. LPC18xx Pin description (flash-based parts) ...continued

Pin name	LPGA256	TFBGA100	LQFP144	LQFP208	Reset state	Type	Description
PE_3	K12	-	-	118	N; PU	-	R — Function reserved.
						O	CAN0_TD — CAN transmitter output.
						I	ADCTRIG1 — ADC trigger input 1.
						I/O	EMC_A21 — External memory address line 21.
						I/O	GPIO7[3] — General purpose digital input/output pin.
						-	R — Function reserved.
						-	R — Function reserved.
						-	R — Function reserved.
PE_4	K13	-	-	120	N; PU	-	R — Function reserved.
						I	NMI — External interrupt input to NMI.
						-	R — Function reserved.
						I/O	EMC_A22 — External memory address line 22.
						I/O	GPIO7[4] — General purpose digital input/output pin.
						-	R — Function reserved.
						-	R — Function reserved.
						-	R — Function reserved.
PE_5	N16	-	-	122	N; PU	-	R — Function reserved.
						O	CTOUT_3 — SCT output 3. Match output 3 of timer 0.
						O	U1_RTS — Request to Send output for UART1. Can also be configured to be an RS-485/EIA-485 output enable signal for UART1.
						I/O	EMC_D24 — External memory data line 24.
						I/O	GPIO7[5] — General purpose digital input/output pin.
						-	R — Function reserved.
						-	R — Function reserved.
						-	R — Function reserved.
PE_6	M16	-	-	124	N; PU	-	R — Function reserved.
						O	CTOUT_2 — SCT output 2. Match output 2 of timer 0.
						I	U1_RI — Ring Indicator input for UART1.
						I/O	EMC_D25 — External memory data line 25.
						I/O	GPIO7[6] — General purpose digital input/output pin.
						-	R — Function reserved.
						-	R — Function reserved.
						-	R — Function reserved.

Table 170. LPC18xx Pin description (flash-based parts) ...continued

Pin name	LPGA256	TFBGA100	LQFP144	LQFP208	Reset state	Type	Description
PE_7	F15	-	-	149	N; PU	-	R — Function reserved.
						O	CTOUT_5 — SCT output 5. Match output 3 of timer 3.
						I	U1_CTS — Clear to Send input for UART1.
						I/O	EMC_D26 — External memory data line 26.
						I/O	GPIO7[7] — General purpose digital input/output pin.
						-	R — Function reserved.
						-	R — Function reserved.
						-	R — Function reserved.
PE_8	F14	-	-	150	N; PU	-	R — Function reserved.
						O	CTOUT_4 — SCT output 4. Match output 3 of timer 3.
						I	U1_DSR — Data Set Ready input for UART1.
						I/O	EMC_D27 — External memory data line 27.
						I/O	GPIO7[8] — General purpose digital input/output pin.
						-	R — Function reserved.
						-	R — Function reserved.
						-	R — Function reserved.
PE_9	E16	-	-	152	N; PU	-	R — Function reserved.
						I	CTIN_4 — SCT input 4. Capture input 2 of timer 1.
						I	U1_DCD — Data Carrier Detect input for UART1.
						I/O	EMC_D28 — External memory data line 28.
						I/O	GPIO7[9] — General purpose digital input/output pin.
						-	R — Function reserved.
						-	R — Function reserved.
						-	R — Function reserved.
PE_10	E14	-	-	154	N; PU	-	R — Function reserved.
						I	CTIN_3 — SCT input 3. Capture input 1 of timer 1.
						O	U1_DTR — Data Terminal Ready output for UART1. Can also be configured to be an RS-485/EIA-485 output enable signal for UART1.
						I/O	EMC_D29 — External memory data line 29.
						I/O	GPIO7[10] — General purpose digital input/output pin.
						-	R — Function reserved.
						-	R — Function reserved.
						-	R — Function reserved.

Table 170. LPC18xx Pin description (flash-based parts) ...continued

Pin name	LPGA256	TFBGA100	LQFP144	LQFP208	Reset state	Type	Description
PE_11	D16	-	-	-	N; PU	-	R — Function reserved.
						O	CTOUT_12 — SCT output 12. Match output 3 of timer 3.
						O	U1_TXD — Transmitter output for UART1.
						I/O	EMC_D30 — External memory data line 30.
						I/O	GPIO7[11] — General purpose digital input/output pin.
						-	R — Function reserved.
						-	R — Function reserved.
PE_12	D15	-	-	-	N; PU	-	R — Function reserved.
						O	CTOUT_11 — SCT output 11. Match output 3 of timer 2.
						I	U1_RXD — Receiver input for UART1.
						I/O	EMC_D31 — External memory data line 31.
						I/O	GPIO7[12] — General purpose digital input/output pin.
						-	R — Function reserved.
						-	R — Function reserved.
PE_13	G14	-	-	-	N; PU	-	R — Function reserved.
						O	CTOUT_14 — SCT output 14. Match output 2 of timer 3.
						I/O	I2C1_SDA — I ² C1 data input/output (this pin does not use a specialized I ² C pad).
						O	EMC_DQMOUT3 — Data mask 3 used with SDRAM and static devices.
						I/O	GPIO7[13] — General purpose digital input/output pin.
						-	R — Function reserved.
						-	R — Function reserved.
PE_14	C15	-	-	-	N; PU	-	R — Function reserved.
						-	R — Function reserved.
						-	R — Function reserved.
						O	EMC_DYCS3 — SDRAM chip select 3.
						I/O	GPIO7[14] — General purpose digital input/output pin.
						-	R — Function reserved.
						-	R — Function reserved.

Table 170. LPC18xx Pin description (flash-based parts) ...continued

Pin name	LPGA256	TFBGA100	LQFP144	LQFP208	Reset state	Type	Description
PE_15	E13	-	-	-	N; PU	-	R — Function reserved.
						O	CTOUT_0 — SCT output 0. Match output 0 of timer 0.
						I/O	I2C1_SCL — I ² C1 clock input/output (this pin does not use a specialized I ² C pad).
						O	EMC_CKEOUT3 — SDRAM clock enable 3.
						I/O	GPIO7[15] — General purpose digital input/output pin.
						-	R — Function reserved.
						-	R — Function reserved.
PF_0	D12	-	-	159	OL; PU	I/O	SSP0_SCK — Serial clock for SSP0.
						I	GP_CLKIN — General purpose clock input to the CGU.
						-	R — Function reserved.
						-	R — Function reserved.
						-	R — Function reserved.
						-	R — Function reserved.
						-	R — Function reserved.
PF_1	E11	-	-	-	N; PU	-	R — Function reserved.
						-	R — Function reserved.
						I/O	SSP0_SSEL — Slave Select for SSP0.
						-	R — Function reserved.
						I/O	GPIO7[16] — General purpose digital input/output pin.
						-	R — Function reserved.
						-	R — Function reserved.
PF_2	D11	-	-	168	N; PU	-	R — Function reserved.
						O	U3_TXD — Transmitter output for USART3.
						I/O	SSP0_MISO — Master In Slave Out for SSP0.
						-	R — Function reserved.
						I/O	GPIO7[17] — General purpose digital input/output pin.
						-	R — Function reserved.
						-	R — Function reserved.

Table 170. LPC18xx Pin description (flash-based parts) ...continued

Pin name	LPGA256	TFBGA100	LQFP144	LQFP208	Reset state	Type	Description
PF_3	E10	-	-	170	N; PU	-	R — Function reserved.
						I	U3_RXD — Receiver input for USART3.
						I/O	SSP0_MOSI — Master Out Slave in for SSP0.
						-	R — Function reserved.
						I/O	GPIO7[18] — General purpose digital input/output pin.
						-	R — Function reserved.
						-	R — Function reserved.
						-	R — Function reserved.
PF_4	D10	H4	120	172	OL; PU	I/O	SSP1_SCK — Serial clock for SSP1.
						I	GP_CLKIN — General purpose clock input to the CGU.
						O	TRACECLK — Trace clock.
						-	R — Function reserved.
						-	R — Function reserved.
						-	R — Function reserved.
						O	I2S0_TX_MCLK — I ² S transmit master clock.
						I/O	I2S0_RX_SCK — I ² S receive clock. It is driven by the master and received by the slave. Corresponds to the signal SCK in the I ² S-bus specification.
PF_5	E9	-	-	190	N; PU	-	R — Function reserved.
						I/O	U3_UCLK — Serial clock input/output for USART3 in synchronous mode.
						I/O	SSP1_SSEL — Slave Select for SSP1.
						O	TRACEDATA[0] — Trace data, bit 0.
						I/O	GPIO7[19] — General purpose digital input/output pin.
						-	R — Function reserved.
						-	R — Function reserved.
						-	R — Function reserved.
AI	ADC1_4 — ADC1 and ADC0, input channel 4. Configure the pin as GPIO input and use the ADC function select register in the SCU to select the ADC.						

Table 170. LPC18xx Pin description (flash-based parts) ...continued

Pin name	LPGA256	TFBGA100	LQFP144	LQFP208	Reset state	Type	Description
PF_6	E7	-	-	192	[5] N; PU	-	R — Function reserved.
						I/O	U3_DIR — RS-485/EIA-485 output enable/direction control for USART3.
						I/O	SSP1_MISO — Master In Slave Out for SSP1.
						O	TRACEDATA[1] — Trace data, bit 1.
						I/O	GPIO7[20] — General purpose digital input/output pin.
						-	R — Function reserved.
						-	R — Function reserved.
						I/O	I2S1_TX_SDA — I2S1 transmit data. It is driven by the transmitter and read by the receiver. Corresponds to the signal SD in the <i>I²S-bus specification</i> .
PF_7	B7	-	-	193	[5] N; PU	-	R — Function reserved.
						I/O	U3_BAUD — Baud pin USART3.
						I/O	SSP1_MOSI — Master Out Slave in for SSP1.
						O	TRACEDATA[2] — Trace data, bit 2.
						I/O	GPIO7[21] — General purpose digital input/output pin.
						-	R — Function reserved.
						-	R — Function reserved.
						I/O	I2S1_TX_WS — Transmit Word Select. It is driven by the master and received by the slave. Corresponds to the signal WS in the <i>I²S-bus specification</i> .
PF_8	E6	-	-	-	[5] N; PU	-	R — Function reserved.
						I/O	U0_UCLK — Serial clock input/output for USART0 in synchronous mode.
						I	CTIN_2 — SCT input 2. Capture input 2 of timer 0.
						O	TRACEDATA[3] — Trace data, bit 3.
						I/O	GPIO7[22] — General purpose digital input/output pin.
						-	R — Function reserved.
						-	R — Function reserved.
						-	R — Function reserved.
AI	ADC0_2 — ADC0 and ADC1, input channel 2. Configure the pin as GPIO input and use the ADC function select register in the SCU to select the ADC.						

Table 170. LPC18xx Pin description (flash-based parts) ...continued

Pin name	LPGA256	TFBGA100	LQFP144	LQFP208	Reset state	Type	Description
PF_9	D6	-	-	203	[5] N; PU	-	R — Function reserved.
						I/O	U0_DIR — RS-485/EIA-485 output enable/direction control for USART0.
						O	CTOUT_1 — SCT output 1. Match output 3 of timer 3.
						-	R — Function reserved.
						I/O	GPIO7[23] — General purpose digital input/output pin.
						-	R — Function reserved.
						-	R — Function reserved.
PF_10	A3	-	-	205	[5] N; PU	-	R — Function reserved.
						O	U0_TXD — Transmitter output for USART0.
						-	R — Function reserved.
						-	R — Function reserved.
						I/O	GPIO7[24] — General purpose digital input/output pin.
						-	R — Function reserved.
						I	SD_WP — SD/MMC card write protect input.
PF_11	A2	-	-	207	[5] N; PU	-	R — Function reserved.
						I	U0_RXD — Receiver input for USART0.
						-	R — Function reserved.
						-	R — Function reserved.
						I/O	GPIO7[25] — General purpose digital input/output pin.
						-	R — Function reserved.
						O	SD_VOLT2 — SD/MMC bus voltage select output 2.
-	R — Function reserved.						
PF_11	A2	-	-	207	[5] N; PU	-	R — Function reserved.
						AI	ADC1_5 — ADC1 and ADC0, input channel 5. Configure the pin as GPIO input and use the ADC function select register in the SCU to select the ADC.

Clock pins

Table 170. LPC18xx Pin description (flash-based parts) ...continued

Pin name	LPGA256	TFBGA100	LQFP144	LQFP208	Reset state	Type	Description
CLK0	N5	K3	45	62	[4] O; PU	O	EMC_CLK0 — SDRAM clock 0.
							CLKOUT — Clock output pin.
							- R — Function reserved.
							- R — Function reserved.
							I/O SD_CLK — SD/MMC card clock.
							O EMC_CLK01 — SDRAM clock 0 and clock 1 combined.
							I/O SSP1_SCK — Serial clock for SSP1.
							I ENET_TX_CLK (ENET_REF_CLK) — Ethernet Transmit Clock (MII interface) or Ethernet Reference Clock (RMII interface).
CLK1	T10	-	-	-	[4] O; PU	O	EMC_CLK1 — SDRAM clock 1.
							CLKOUT — Clock output pin.
							- R — Function reserved.
							- R — Function reserved.
							- R — Function reserved.
							O CGU_OUT0 — CGU spare clock output 0.
							- R — Function reserved.
							O I2S1_TX_MCLK — I ² S1 transmit master clock.
CLK2	D14	K6	99	141	[4] O; PU	O	EMC_CLK3 — SDRAM clock 3.
							CLKOUT — Clock output pin.
							- R — Function reserved.
							- R — Function reserved.
							I/O SD_CLK — SD/MMC card clock.
							O EMC_CLK23 — SDRAM clock 2 and clock 3 combined.
							O I2S0_TX_MCLK — I ² S transmit master clock.
							I/O I2S1_RX_SCK — Receive Clock. It is driven by the master and received by the slave. Corresponds to the signal SCK in the <i>I²S-bus specification</i> .
CLK3	P12	-	-	-	[4] O; PU	O	EMC_CLK2 — SDRAM clock 2.
							CLKOUT — Clock output pin.
							- R — Function reserved.
							- R — Function reserved.
							- R — Function reserved.
							O CGU_OUT1 — CGU spare clock output 1.
							- R — Function reserved.
							I/O I2S1_RX_SCK — Receive Clock. It is driven by the master and received by the slave. Corresponds to the signal SCK in the <i>I²S-bus specification</i> .

Table 170. LPC18xx Pin description (flash-based parts) ...continued

Pin name	LPGA256	TFBGA100	LQFP144	LQFP208	Reset state	Type	Description
Debug pins							
DBGEN	L4	A6	28	41	[2]	I	JTAG interface control signal. Also used for boundary scan.
TCK/SWDCLK	J5	H2	27	38	[2]	I; F	Test Clock for JTAG interface (default) or Serial Wire (SW) clock.
$\overline{\text{TRST}}$	M4	B4	29	42	[2]	I; PU	Test Reset for JTAG interface.
TMS/SWDIO	K6	C4	30	44	[2]	I; PU	Test Mode Select for JTAG interface (default) or SW debug data input/output.
TDO/SWO	K5	H3	31	46	[2]	O	Test Data Out for JTAG interface (default) or SW trace output.
TDI	J4	G3	26	35	[2]	I; PU	Test Data In for JTAG interface.
USB0 pins							
USB0_DP	F2	E1	18	26	[6]	-	I/O USB0 bidirectional D+ line. Do not add an external series resistor.
USB0_DM	G2	E2	20	28	[6]	-	I/O USB0 bidirectional D- line. Do not add an external series resistor.
USB0_VBUS	F1	E3	21	29	[6] [7]	-	VBUS pin (power on USB cable). This pin includes an internal pull-down resistor of 70 k Ω (typical) \pm 30 k Ω .
USB0_ID	H2	F1	22	30	[8]	-	I Indicates to the transceiver whether connected as an A-device (USB0_ID LOW) or B-device (USB0_ID HIGH). For use with OTG, this pin has an internal pull-up resistor.
USB0_RREF	H1	F3	24	32	[8]	-	12.0 k Ω (accuracy 1 %) on-board resistor to ground for current reference.
USB1 pins							
USB1_DP	F12	E9	89	129	[9]	-	I/O USB1 bidirectional D+ line. Add an external series resistor of 33 Ω +/- 2 %.
USB1_DM	G12	E10	90	130	[9]	-	I/O USB1 bidirectional D- line. Add an external series resistor of 33 Ω +/- 2 %.
I²C-bus pins							
I2C0_SCL	L15	D6	92	132	[10]	I; F	I/O I ² C clock input/output. Open-drain output (for I ² C-bus compliance).
I2C0_SDA	L16	E6	93	133	[10]	I; F	I/O I ² C data input/output. Open-drain output (for I ² C-bus compliance).
Reset and wake-up pins							
$\overline{\text{RESET}}$	D9	B6	128	185	[11]	I; IA	I External reset input: A LOW-going pulse as short as 50 ns on this pin resets the device, causing I/O ports and peripherals to take on their default states, and processor execution to begin at address 0.
WAKEUP0	A9	A4	130	187	[11]	I; IA	I External wake-up input; can raise an interrupt and can cause wake-up from any of the low power modes. A pulse with a duration of at least 45 ns wakes up the part. Input 0 of the event monitor.

Table 170. LPC18xx Pin description (flash-based parts) ...continued

Pin name	LPGA256	TFBGA100	LQFP144	LQFP208	Reset state [11]	Type	Description
WAKEUP1	A10	-	-	-	[11] I; IA	I	External wake-up input; can raise an interrupt and can cause wake-up from any of the low power modes. A pulse with a duration of at least 45 ns wakes up the part. Input 1 of the event monitor.
WAKEUP2	C9	-	-	-	[11] I; IA	I	External wake-up input; can raise an interrupt and can cause wake-up from any of the low power modes. A pulse with a duration of at least 45 ns wakes up the part. Input 2 of the event monitor.
WAKEUP3	D8	-	-	-	[11] I; IA	I	External wake-up input; can raise an interrupt and can cause wake-up from any of the low power modes. A pulse with a duration of at least 45 ns wakes up the part.
ADC pins							
ADC0_0/ ADC1_0/DAC	E3	A2	6	8	[8] AI; IA	I	ADC input channel 0. Shared between 10-bit ADC0/1 and DAC.
ADC0_1/ ADC1_1	C3	A1	2	4	[8] AI; IA	I	ADC input channel 1. Shared between 10-bit ADC0/1.
ADC0_2/ ADC1_2	A4	B3	143	206	[8] AI; IA	I	ADC input channel 2. Shared between 10-bit ADC0/1.
ADC0_3/ ADC1_3	B5	A3	139	200	[8] AI; IA	I	ADC input channel 3. Shared between 10-bit ADC0/1.
ADC0_4/ ADC1_4	C6	-	138	199	[8] AI; IA	I	ADC input channel 4. Shared between 10-bit ADC0/1.
ADC0_5/ ADC1_5	B3	-	144	208	[8] AI; IA	I	ADC input channel 5. Shared between 10-bit ADC0/1.
ADC0_6/ ADC1_6	A5	-	142	204	[8] AI; IA	I	ADC input channel 6. Shared between 10-bit ADC0/1.
ADC0_7/ ADC1_7	C5	-	136	197	[8] AI; IA	I	ADC input channel 7. Shared between 10-bit ADC0/1.
RTC pins							
RTC_ALARM	A11	C3	129	186	[11] -	O	RTC controlled output.
RTCX1	A8	A5	125	182	[8] -	I	Input to the RTC 32 kHz ultra-low power oscillator circuit.
RTCX2	B8	B5	126	183	[8] -	O	Output from the RTC 32 kHz ultra-low power oscillator circuit.
SAMPLE	B9	-	-	-	[11] O	O	Event monitor sample output.
Crystal oscillator pins							
XTAL1	D1	B1	12	18	[8] -	I	Input to the oscillator circuit and internal clock generator circuits.
XTAL2	E1	C1	13	19	[8] -	O	Output from the oscillator amplifier.
Power and ground pins							
USB0_VDDA 3V3_DRIVER	F3	D1	16	24	-	-	Separate analog 3.3 V power supply for driver.
USB0 _VDDA3V3	G3	D2	17	25	-	-	USB 3.3 V separate power supply voltage.

Table 170. LPC18xx Pin description (flash-based parts) ...continued

Pin name	LBGA256	TFBGA100	LQFP144	LQFP208	Reset state [1]	Type	Description
USB0_VSSA_TERM	H3	D3	19	27	-	-	Dedicated analog ground for clean reference for termination resistors.
USB0_VSSA_REF	G1	F2	23	31	-	-	Dedicated clean analog ground for generation of reference currents and voltages.
VDDA	B4	B2	137	198	-	-	Analog power supply and ADC reference voltage.
VBAT	B10	C5	127	184	-	-	RTC power supply: 3.3 V on this pin supplies power to the RTC.
VDDREG	F10, F9, L8, L7	E4, E5, F4	94, 131, 59, 25	135, 188, 195, 82, 33	-	-	Main regulator power supply.
VPP	E8	-	-	-	[12]	-	OTP programming voltage.
VDDIO	D7, E12, F7, F8, G10, H10, J6, J7, K7, L9, L10, N7, N13	F10, K5	5, 36, 41, 71, 77, 107, 111, 141	6, 52, 57, 102, 110, 155, 160, 202	[12]	-	I/O power supply.
VSS	G9, H7, J10, J11, K8	C8, D4, D5, G8, J3, J6	-	-	[13]	-	Ground.
VSSIO	C4, D13, G6, G7, G8, H8, H9, J8, J9, K9, K10, M13, P7, P13	-	4, 40, 76, 109	5, 56, 109, 157	[13]	-	Ground.
VSSA	B2	C2	135	196	-	-	Analog ground.

- [1] N = neutral, input buffer disabled; no extra VDDIO current consumption if the input is driven midway between supplies; set the EZI bit in the SFS register to enable the input buffer; I = input, OL = output driving LOW; OH = output driving HIGH; AI/O = analog input/output; IA = inactive; PU = pull-up enabled (weak pull-up resistor pulls up pin to VDDIO; F = floating. Reset state reflects the pin state at reset without boot code operation.
- [2] 5 V tolerant pad with 15 ns glitch filter (5 V tolerant if VDDIO present; if VDDIO not present, do not exceed 3.6 V); provides digital I/O functions with TTL levels and hysteresis; normal drive strength.
- [3] 5 V tolerant pad with 15 ns glitch filter (5 V tolerant if VDDIO present; if VDDIO not present, do not exceed 3.6 V) providing digital I/O functions with TTL levels, and hysteresis; high drive strength.
- [4] 5 V tolerant pad with 15 ns glitch filter (5 V tolerant if VDDIO present; if VDDIO not present, do not exceed 3.6 V) providing high-speed digital I/O functions with TTL levels and hysteresis.
- [5] 5 V tolerant pad providing digital I/O functions (with TTL levels and hysteresis) and analog input or output (5 V tolerant if VDDIO present; if VDDIO not present, do not exceed 3.6 V). When configured as an ADC input or DAC output, the pin is not 5 V tolerant. For analog functionality, disable the digital section of the pad by setting the pin to an input function and by disabling the pull-up resistor through the corresponding SFSP register.
- [6] 5 V tolerant transparent analog pad.
- [7] For maximum load $C_L = 6.5 \mu\text{F}$ and maximum resistance $R_{pd} = 80 \text{ k}\Omega$, the VBUS signal takes about 2 s to fall from VBUS = 5 V to VBUS = 0.2 V when it is no longer driven.
- [8] Transparent analog pad. Not 5 V tolerant.
- [9] Pad provides USB functions; It is designed in accordance with the USB specification, revision 2.0 (Full-speed and Low-speed mode only).
- [10] Open-drain 5 V tolerant digital I/O pad, compatible with I²C-bus Fast Mode Plus specification. This pad requires an external pull-up to provide output functionality. When power is switched off, this pin connected to the I²C-bus is floating and does not disturb the I²C lines.
- [11] 5 V tolerant pad with 20 ns glitch filter; provides digital I/O functions with open-drain output with weak pull-up resistor and hysteresis.
- [12] On the LQFP208 package, VPP is internally connected to VDDIO.
- [13] On the LQFP208 package, VSSIO and VSS are connected to a common ground plane.

16.1 How to read this chapter

The following peripherals are not available on all parts, and the corresponding bit values that select those functions in the SFSP registers are reserved:

- Ethernet: available on LPC185x/3x only.
- USB0: available on LPC185x/3x/2x only.
- USB1: available on LPC185x/3x only.
- LCD: available on LPC185x only.

Remark: The ADC input channels are shared between ADC0 and ADC1 on all LPC18xx parts. This means that input ADC0_n is connected to channel n on ADC0 and ADC1 and input ADC1_n is connected to channel n on ADC0 and ADC1. See [Table 180](#) and [Table 182](#).

16.2 Basic configuration

The SCU is configured as follows:

- See [Table 171](#) for clocking and power control.
- The SCU is reset by the SCU_RST (reset # 9).

Remark: Before using any of the multiplexed pins or the I2C0 pins **as inputs**, set the corresponding pin configuration registers as follows:

- Enable the input buffer by setting bit EZI to 1.
- For high-frequency signals, disable the input glitch filter by setting bit ZIF to 1.

Table 171. SCU clocking and power control

	Base clock	Branch clock	Operating frequency
Clock to SCU register interface	BASE_M3_CLK	CLK_M3_SCU	up to 180 MHz

16.3 General description

The system control unit determines the function and electrical mode of most digital pins. By default, the digital function 0 with pull-up enabled is selected for all pins .

Remark: Some pins support pin muxing of digital and analog functions. All analog I/Os for the ADC and DAC are also pinned out on analog-only pads without pin muxing.

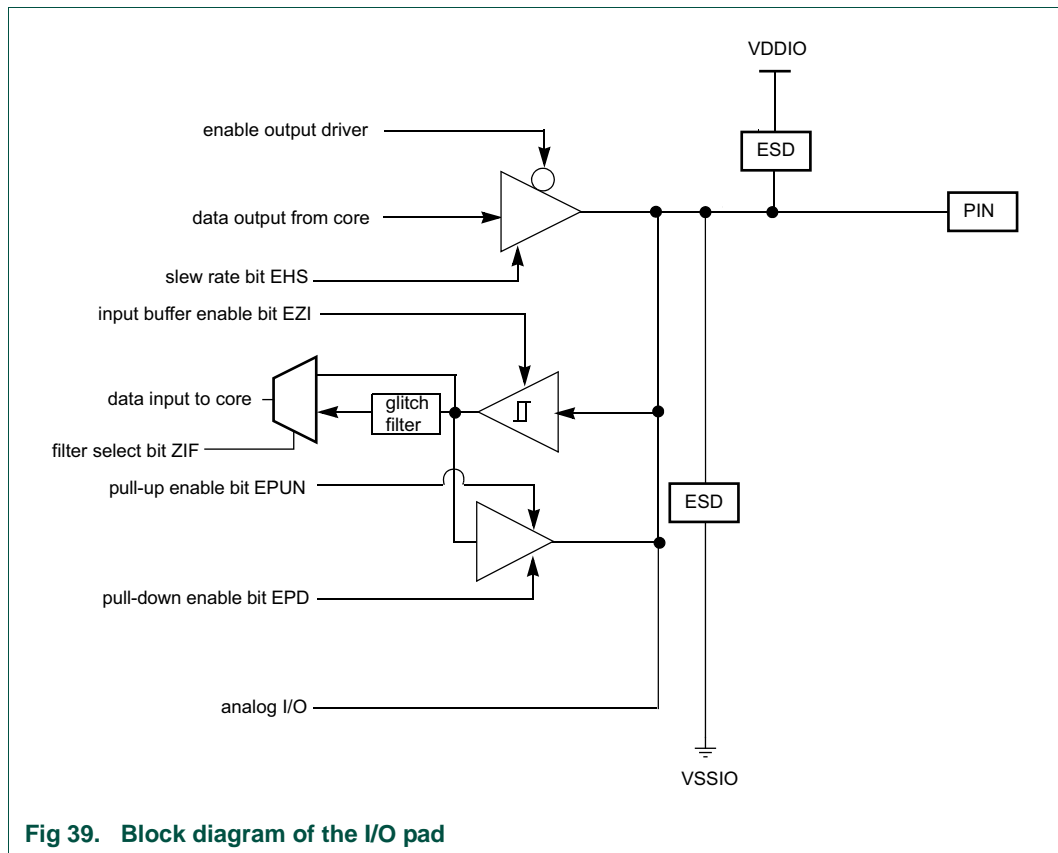

Fig 39. Block diagram of the I/O pad

16.3.1 Digital pin function

The FUNC bits in the SFS registers control the function of each pin. Each pin supports up to 8 digital functions. Some pins support an additional analog function. If the function is GPIO, the GPIO DIR registers determine whether the pin is configured as an input or output (see [Table 243](#)). For any peripheral function, the pin direction is controlled automatically depending on the pin's functionality. The GPIO DIR registers do not affect peripheral functions.

16.3.2 Digital pin mode

The EPUN and EPD bits (see [Figure 39](#)) in the SFS registers allow the selection of weak on-chip pull-up or pull-down resistors with a typical value of 50 k Ω for each pin or the selection of the repeater mode.

The possible on-chip resistor configurations are pull-up enabled, pull-down enabled, or no pull-up/pull-down. The default value is pull-up enabled.

The repeater mode enables the pull-up resistor if the pin is at a logic HIGH and enables the pull-down resistor if the pin is at a logic LOW. This causes the pin to retain its last known state if it is configured as an input and is not driven externally. Repeater mode may typically be used to prevent a pin from floating (and potentially using significant power if it floats to an indeterminate state) if it is temporarily not driven.

To select the repeater mode, enable both the pull-up and the pull-down resistors in the SFS registers.

16.3.3 Input buffer

To be able to receive a digital signal, the input buffer must be enabled through bit EZI in the pin configuration registers (see [Figure 39](#)). By default, the input buffer is disabled.

For pads that support both a digital and an analog function, the input buffer must be disabled before enabling the analog function (see [Section 16.4.6](#) to [Section 16.4.8](#)).

16.3.4 Programmable glitch filter

All digital pins support a programmable glitch filter (bit ZIF), which can be switched on or off (see [Figure 39](#)). By default, the glitch filter is on. The glitch filter should be disabled for clocking signals with frequencies higher than 30 MHz.

16.3.5 Programmable slew rate

Normal-drive and high-speed pins support a programmable slew rate (bit EHS) to select between lower noise and speed or higher noise and speed (see [Figure 39](#)). The typical frequencies supported are 50 MHz/80 MHz for normal-drive pins and 75 MHz/180 MHz for high-speed pins.

16.3.6 High-speed pins

The clock pins CLK0 to CLK3 and P3_3 support a programmable high-speed output with typical frequencies of 75 MHz or 180 MHz depending on the slew rate setting (see [Section 16.3.5](#)).

16.3.7 High-drive pins

Selected pins (see [Section 16.4.2](#)) support a high-drive output with four programmable levels.

High-drive pins support the programmable glitch filter but not the programmable slew rate.

16.3.8 I²C0-bus pins

The SFSI2C0 register ([Table 178](#)) allows to configure different modes for I²C0-bus interface:

- Standard mode/Fast-mode I²C with an open-drain output according to the I²C-bus specification. This is the default mode.
- Fast-mode Plus mode with an open-drain output according to the I²C-bus specification.

The I2C0 pins use a programmable glitch filter (bit ZIF).

Remark: The input buffer must be enabled for the I2C0 pins SDA and SCL for proper operation.

16.3.9 USB1 USB1_DP/USB1_DM pins

The input signal to the USB1 is controlled by the SFSUSB register ([Table 177](#)). The USB_ESEA bit in this register must be set to one to enable the USB1 block.

16.3.10 EMC signal delay control

The SCU contains a programmable delay control for the EMC SDRAM clocks (see [Table 185](#)).

16.3.11 Pin multiplexing

Multiplexed digital pins are grouped into 16 pin groups, named P0 to P9 and PA to PF, with up to 20 pins used per group. Each digital pin can support up to eight different digital functions, including General Purpose I/O (GPIO), selectable through the SCU registers. In addition, some pins support an analog function (ADC inputs and DAC output) selectable through the ENAIO registers. Note that the pin name is not indicative of the GPIO port assigned to it.

The multiplexer selections are shown in [Table 172](#).

Table 172. Pin multiplexing

Pin name	MODE bits =							
	0	1	2	3	4	5	6	7
P0_0	GPIO0[0]	SSP1_MISO	ENET_RXD1	R	R	R	I2S0_TX_WS	I2S1_
P0_1	GPIO0[1]	SSP1_MOSI	ENET_COL	R	R	R	ENET_TX_EN	I2S1_
P1_0	GPIO0[4]	CTIN_3	EMC_A5	R	R	SSP0_SSEL	R	EMC_
P1_1	GPIO0[8]	CTOUT_7	EMC_A6	R	R	SSP0_MISO	R	EMC_
P1_2	GPIO0[9]	CTOUT_6	EMC_A7	R	R	SSP0_MOSI	R	EMC_
P1_3	GPIO0[10]	CTOUT_8	R	EMC_OE	USB0_IND1	SSP1_MISO	R	SD_RS
P1_4	GPIO0[11]	CTOUT_9	R	EMC_BLS0	USB0_IND0	SSP1_MOSI	EMC_D15 ^[1]	SD_VO
P1_5	GPIO1[8]	CTOUT_10	R	EMC_CS0	USB0_PWR_FAULT	SSP1_SSEL	R	SD_PO
P1_6	GPIO1[9]	CTIN_5	R	EMC_WE	R	EMC_BLS0 ^[1]	R	SD_CI
P1_7	GPIO1[0]	U1_DSR	CTOUT_13	EMC_D0	USB0_PWR_EN	R	R	R
P1_8	GPIO1[1]	U1_DTR	CTOUT_12	EMC_D1	R	R	R	SD_VO
P1_9	GPIO1[2]	U1_RTS	CTOUT_11	EMC_D2	R	R	R	SD_DA
P1_10	GPIO1[3]	U1_RI	CTOUT_14	EMC_D3	R	R	R	SD_DA
P1_11	GPIO1[4]	U1_CTS	CTOUT_15	EMC_D4	R	R	R	SD_DA
P1_12	GPIO1[5]	U1_DCD	R	EMC_D5	T0_CAP1	R	R	SD_DA
P1_13	GPIO1[6]	U1_TXD	R	EMC_D6	T0_CAP0	R	R	SD_CI
P1_14	GPIO1[7]	U1_RXD	R	EMC_D7	T0_MAT2	R	R	R
P1_15	GPIO0[2]	U2_TXD	R	ENET_RXD0	T0_MAT1	R	EMC_D8 ^[1]	R
P1_16	GPIO0[3]	U2_RXD	R	ENET_CRS	T0_MAT0	R	EMC_D9 ^[1]	ENET_DV
P1_17	GPIO0[12]	U2_UCLK	R	ENET_MDIO	T0_CAP3	CAN1_TD	R	R
P1_18	GPIO0[13]	U2_DIR	R	ENET_TXD0	T0_MAT3	CAN1_RD	R	EMC_
P1_19	ENET_TX_CLK (ENET_REF_CLK)	SSP1_SCK	R	R	CLKOUT	R	I2S0_RX_MCLK	I2S1_
P1_20	GPIO0[15]	SSP1_SSEL	R	ENET_TXD1	T0_CAP2	R	R	EMC_
P2_0	R	U0_TXD	EMC_A13	USB0_PWR_EN	GPIO5[0]	R	T3_CAP0	ENET_

Table 172. Pin multiplexing

Pin name	MODE bits =							
	0	1	2	3	4	5	6	7
P2_1	R	U0_RXD	EMC_A12	USB0_PWR_F AULT	GPIO5[1]	R	T3_CAP1	R
P2_2	R	U0_UCLK	EMC_A11	USB0_IND1	GPIO5[2]	CTIN_6	T3_CAP2	EMC_
P2_3	R	I2C1_SDA	U3_TXD	CTIN_1	GPIO5[3]	R	T3_MAT0	USB0_ N
P2_4	R	I2C1_SCL	U3_RXD	CTIN_0	GPIO5[4]	R	T3_MAT1	USB0_ AULT
P2_5	R	CTIN_2	USB1_VBUS	ADCTRIG1	GPIO5[5]	R	T3_MAT2	USB0_
P2_6	R	U0_DIR	EMC_A10	USB0_IND0	GPIO5[6]	CTIN_7	T3_CAP3	EMC_
P2_7	GPIO0[7]	CTOUT_1	U3_UCLK	EMC_A9	R	R	T3_MAT3	R
P2_8	R	CTOUT_0	U3_DIR	EMC_A8	GPIO5[7]	R	R	R
P2_9	GPIO1[10]	CTOUT_3	U3_BAUD	EMC_A0	R	R	R	R
P2_10	GPIO0[14]	CTOUT_2	U2_TXD	EMC_A1	R	R	R	R
P2_11	GPIO1[11]	CTOUT_5	U2_RXD	EMC_A2	R	R	R	R
P2_12	GPIO1[12]	CTOUT_4	R	EMC_A3	R	R	R	U2_UC
P2_13	GPIO1[13]	CTIN_4	R	EMC_A4	R	R	R	U2_DI
P3_0	I2S0_RX_SCK	I2S0_RX_ MCLK	I2S0_TX_SCK	I2S0_TX_MCLK	SSP0_SCK	R	R	R
P3_1	I2S0_TX_WS	I2S0_RX_WS	CAN0_RD	USB1_IND1	GPIO5[8]	R	LCD_VD15	R
P3_2	I2S0_TX_SDA	I2S0_RX_SDA	CAN0_TD	USB1_IND0	GPIO5[9]	R	LCD_VD14	R
P3_3	R	R	SSP0_SCK	SPIFI_SCK	CGU_OUT1	R	I2S0_TX_MCLK	I2S1_
P3_4	GPIO1[14]	R	R	SPIFI_SIO3	U1_TXD	I2S0_TX_WS	I2S1_RX_SDA	LCD_V
P3_5	GPIO1[15]	R	R	SPIFI_SIO2	U1_RXD	I2S0_TX_SDA	I2S1_RX_WS	LCD_V
P3_6	GPIO0[6]	R	SSP0_SSEL	SPIFI_MISO	R	SSP0_MISO	R	R
P3_7	R	R	SSP0_MISO	SPIFI_MOSI	GPIO5[10]	SSP0_MOSI	R	R
P3_8	R	R	SSP0_MOSI	SPIFI_CS	GPIO5[11]	SSP0_SSEL	R	R
P4_0	GPIO2[0]	MCOA0	NMI	R	R	LCD_VD13	U3_UCLK	R
P4_1	GPIO2[1]	CTOUT_1	LCD_VD0	R	R	LCD_VD19	U3_TXD	ENET_
P4_2	GPIO2[2]	CTOUT_0	LCD_VD3	R	R	LCD_VD12	U3_RXD	R
P4_3	GPIO2[3]	CTOUT_3	LCD_VD2	R	R	LCD_VD21	U3_BAUD	R

Table 172. Pin multiplexing

Pin name	MODE bits =							
	0	1	2	3	4	5	6	7
P4_4	GPIO2[4]	CTOUT_2	LCD_VD1	R	R	LCD_VD20	U3_DIR	R
P4_5	GPIO2[5]	CTOUT_5	LCD_FP	R	R	R	R	R
P4_6	GPIO2[6]	CTOUT_4	LCD_ENAB/LC DM	R	R	R	R	R
P4_7	LCD_DCLK	GP_CLKIN	R	R	R	R	I2S1_TX_SCK	I2S0_
P4_8	R	CTIN_5	LCD_VD9	R	GPIO5[12]	LCD_VD22	CAN1_TD	R
P4_9	R	CTIN_6	LCD_VD11	R	GPIO5[13]	LCD_VD15	CAN1_RD	R
P4_10	R	CTIN_2	LCD_VD10	R	GPIO5[14]	LCD_VD14	R	R
P5_0	GPIO2[9]	MCOB2	EMC_D12	R	U1_DSR	T1_CAP0	R	R
P5_1	GPIO2[10]	MCI2	EMC_D13	R	U1_DTR	T1_CAP1	R	R
P5_2	GPIO2[11]	MCI1	EMC_D14	R	U1_RTS	T1_CAP2	R	R
P5_3	GPIO2[12]	MCI0	EMC_D15	R	U1_RI	T1_CAP3	R	R
P5_4	GPIO2[13]	MCOB0	EMC_D8	R	U1_CTS	T1_MAT0	R	R
P5_5	GPIO2[14]	MCOA1	EMC_D9	R	U1_DCD	T1_MAT1	R	R
P5_6	GPIO2[15]	MCOB1	EMC_D10	R	U1_TXD	T1_MAT2	R	R
P5_7	GPIO2[7]	MCOA2	EMC_D11	R	U1_RXD	T1_MAT3	R	R
P6_0	R	I2S0_RX_ MCLK	R	R	I2S0_RX_SCK	R	R	R
P6_1	GPIO3[0]	EMC_DYCS1	U0_UCLK	I2S0_RX_WS	R	T2_CAP0	R	R
P6_2	GPIO3[1]	EMC_ CKEOUT1	U0_DIR	I2S0_RX_SDA	R	T2_CAP1	R	R
P6_3	GPIO3[2]	USB0_PWR_ EN	R	EMC_CS1	R	T2_CAP2	R	R
P6_4	GPIO3[3]	CTIN_6	U0_TXD	EMC_CAS	R	R	R	R
P6_5	GPIO3[4]	CTOUT_6	U0_RXD	EMC_RAS	R	R	R	R
P6_6	GPIO0[5]	EMC_BLS1	R	USB0_PWR_F AULT	R	T2_CAP3	R	R
P6_7	R	EMC_A15	R	USB0_IND1	GPIO5[15]	T2_MAT0	R	R
P6_8	R	EMC_A14	R	USB0_IND0	GPIO5[16]	T2_MAT1	R	R
P6_9	GPIO3[5]	R	R	EMC_DYCS0	R	T2_MAT2	R	R

Table 172. Pin multiplexing

Pin name	MODE bits =							
	0	1	2	3	4	5	6	7
P6_10	GPIO3[6]	MCABORT	R	EMC_DQMOUT 1	R	R	R	R
P6_11	GPIO3[7]	R	R	EMC_CKEOUT 0	R	T2_MAT3	R	R
P6_12	GPIO2[8]	CTOUT_7	R	EMC_DQMOUT 0	R	R	R	R
P7_0	GPIO3[8]	CTOUT_14	R	LCD_LE	R	R	R	R
P7_1	GPIO3[9]	CTOUT_15	I2S0_TX_WS	LCD_VD19	LCD_VD7	R	U2_TXD	R
P7_2	GPIO3[10]	CTIN_4	I2S0_TX_SDA	LCD_VD18	LCD_VD6	R	U2_RXD	R
P7_3	GPIO3[11]	CTIN_3	R	LCD_VD17	LCD_VD5	R	R	R
P7_4	GPIO3[12]	CTOUT_13	R	LCD_VD16	LCD_VD4	TRACEDATA[0]	R	R
P7_5	GPIO3[13]	CTOUT_12	R	LCD_VD8	LCD_VD23	TRACEDATA[1]	R	R
P7_6	GPIO3[14]	CTOUT_11	R	LCD_LP	R	TRACEDATA[2]	R	R
P7_7	GPIO3[15]	CTOUT_8	R	LCD_PWR	R	TRACEDATA[3]	ENET_MDC	R
P8_0	GPIO4[0]	USB0_PWR_F AULT	R	MCI2	R	R	R	T0_MA
P8_1	GPIO4[1]	USB0_IND1	R	MCI1	R	R	R	T0_MA
P8_2	GPIO4[2]	USB0_IND0	R	MCI0	R	R	R	T0_MA
P8_3	GPIO4[3]	USB1_ULPI_D2	R	LCD_VD12	LCD_VD19	R	R	T0_MA
P8_4	GPIO4[4]	USB1_ULPI_D1	R	LCD_VD7	LCD_VD16	R	R	T0_CA
P8_5	GPIO4[5]	USB1_ULPI_D0	R	LCD_VD6	LCD_VD8	R	R	T0_CA
P8_6	GPIO4[6]	USB1_ULPI_ NXT	R	LCD_VD5	LCD_LP	R	R	T0_CA
P8_7	GPIO4[7]	USB1_ULPI_ STP	R	LCD_VD4	LCD_PWR	R	R	T0_CA
P8_8	R	USB1_ULPI_ CLK	R	R	R	R	CGU_OUT0	I2S1_
P9_0	GPIO4[12]	MCABORT	R	R	R	ENET_CRD	R	SSP0_
P9_1	GPIO4[13]	MCOA2	R	R	I2S0_TX_WS	ENET_RX_ER	R	SSP0_
P9_2	GPIO4[14]	MCOB2	R	R	I2S0_TX_SDA	ENET_RXD3	R	SSP0_
P9_3	GPIO4[15]	MCOA0	USB1_IND1	R	R	ENET_RXD2	R	U3_TX

Table 172. Pin multiplexing

Pin name	MODE bits =							
	0	1	2	3	4	5	6	7
P9_4	R	MCOB0	USB1_IND0	R	GPIO5[17]	ENET_TXD2	R	U3_RX
P9_5	R	MCOA1	USB1_VBUS_EN	R	GPIO5[18]	ENET_TXD3	R	U0_TX
P9_6	GPIO4[11]	MCOB1	USB1_PWR_FAULT	R	R	ENET_COL	R	U0_RX
PA_0	R	R	R	R	R	I2S1_RX_MCLK	CGU_OUT1	R
PA_1	GPIO4[8]	QEI_IDX	R	U2_TXD	R	R	R	R
PA_2	GPIO4[9]	QEI_PHB	R	U2_RXD	R	R	R	R
PA_3	GPIO4[10]	QEI_PHA	R	R	R	R	R	R
PA_4	R	CTOUT_9	R	EMC_A23	GPIO5[19]	R	R	R
PB_0	R	CTOUT_10	LCD_VD23	R	GPIO5[20]	R	R	R
PB_1	R	USB1_ULPI_D1R	LCD_VD22	R	GPIO5[21]	CTOUT_6	R	R
PB_2	R	USB1_ULPI_D7	LCD_VD21	R	GPIO5[22]	CTOUT_7	R	R
PB_3	R	USB1_ULPI_D6	LCD_VD20	R	GPIO5[23]	CTOUT_8	R	R
PB_4	R	USB1_ULPI_D5	LCD_VD15	R	GPIO5[24]	CTIN_5	R	R
PB_5	R	USB1_ULPI_D4	LCD_VD14	R	GPIO5[25]	CTIN_7	LCD_PWR	R
PB_6	R	USB1_ULPI_D3	LCD_VD13	R	GPIO5[26]	CTIN_6	LCD_VD19	R
PC_0	R	USB1_ULPI_CLK	R	ENET_RX_CLK	LCD_DCLK	R	R	SD_C
PC_1	USB1_ULPI_D7	R	U1_RI	ENET_MDC	GPIO6[0]	R	T3_CAP0	SD_VO
PC_2	USB1_ULPI_D6	R	U1_CTS	ENET_TXD2	GPIO6[1]	R	R	SD_RS
PC_3	USB1_ULPI_D5	R	U1_RTS	ENET_TXD3	GPIO6[2]	R	R	SD_VO
PC_4	R	USB1_ULPI_D4	R	ENET_TX_EN	GPIO6[3]	R	T3_CAP1	SD_DA
PC_5	R	USB1_ULPI_D3	R	ENET_TX_ER	GPIO6[4]	R	T3_CAP2	SD_DA
PC_6	R	USB1_ULPI_D2	R	ENET_RXD2	GPIO6[5]	R	T3_CAP3	SD_DA
PC_7	R	USB1_ULPI_D1	R	ENET_RXD3	GPIO6[6]	R	T3_MAT0	SD_DA
PC_8	R	USB1_ULPI_D0	R	ENET_RX_DV	GPIO6[7]	R	T3_MAT1	SD_C
PC_9	R	USB1_ULPI_NXT	R	ENET_RX_ER	GPIO6[8]	R	T3_MAT2	SD_PO

Table 172. Pin multiplexing

Pin name	MODE bits =							
	0	1	2	3	4	5	6	7
PC_10	R	USB1_ULPI_STP	U1_DSR	R	GPIO6[9]	R	T3_MAT3	SD_CD
PC_11	R	USB1_ULPI_DIR	U1_DCD	R	GPIO6[10]	R	R	SD_D0
PC_12	R	R	U1_DTR	R	GPIO6[11]	R	I2S0_TX_SDA	SD_D1
PC_13	R	R	U1_TXD	R	GPIO6[12]	R	I2S0_TX_WS	SD_D2
PC_14	R	R	U1_RXD	R	GPIO6[13]	R	ENET_TX_ER	SD_D3
PD_0	R	CTOUT_15	EMC_DQMOUT2	R	GPIO6[14]	R	R	R
PD_1	R	R	EMC_CKEOUT2	R	GPIO6[15]	SD_POW	R	R
PD_2	R	CTOUT_7	EMC_D16	R	GPIO6[16]	R	R	R
PD_3	R	CTOUT_6	EMC_D17	R	GPIO6[17]	R	R	R
PD_4	R	CTOUT_8	EMC_D18	R	GPIO6[18]	R	R	R
PD_5	R	CTOUT_9	EMC_D19	R	GPIO6[19]	R	R	R
PD_6	R	CTOUT_10	EMC_D20	R	GPIO6[20]	R	R	R
PD_7	R	CTIN_5	EMC_D21	R	GPIO6[21]	R	R	R
PD_8	R	CTIN_6	EMC_D22	R	GPIO6[22]	R	R	R
PD_9	R	CTOUT_13	EMC_D23	R	GPIO6[23]	R	R	R
PD_10	R	CTIN_1	EMC_BLS3	R	GPIO6[24]	R	R	R
PD_11	R	R	EMC_CS3	R	GPIO6[25]	USB1_ULPI_D0	CTOUT_14	R
PD_12	R	R	EMC_CS2	R	GPIO6[26]	R	CTOUT_10	R
PD_13	R	CTIN_0	EMC_BLS2	R	GPIO6[27]	R	CTOUT_13	R
PD_14	R	R	EMC_DYCS2	R	GPIO6[28]	R	CTOUT_11	R
PD_15	R	R	EMC_A17	R	GPIO6[29]	SD_WP	CTOUT_8	R
PD_16	R	R	EMC_A16	R	GPIO6[30]	SD_VOLT2	CTOUT_12	R
PE_0	R	R	R	EMC_A18	GPIO7[0]	CAN1_TD	R	R
PE_1	R	R	R	EMC_A19	GPIO7[1]	CAN1_RD	R	R
PE_2	ADCTRIG0	CAN0_RD	R	EMC_A20	GPIO7[2]	R	R	R
PE_3	R	CAN0_TD	ADCTRIG1	EMC_A21	GPIO7[3]	R	R	R

Table 172. Pin multiplexing

Pin name	MODE bits =							
	0	1	2	3	4	5	6	7
PE_4	R	NMI	R	EMC_A22	GPIO7[4]	R	R	R
PE_5	R	CTOUT_3	U1_RTS	EMC_D24	GPIO7[5]	R	R	R
PE_6	R	CTOUT_2	U1_RI	EMC_D25	GPIO7[6]	R	R	R
PE_7	R	CTOUT_5	U1_CTS	EMC_D26	GPIO7[7]	R	R	R
PE_8	R	CTOUT_4	U1_DSR	EMC_D27	GPIO7[8]	R	R	R
PE_9	R	CTIN_4	U1_DCD	EMC_D28	GPIO7[9]	R	R	R
PE_10	R	CTIN_3	U1_DTR	EMC_D29	GPIO7[10]	R	R	R
PE_11	R	CTOUT_12	U1_TXD	EMC_D30	GPIO7[11]	R	R	R
PE_12	R	CTOUT_11	U1_RXD	EMC_D31	GPIO7[12]	R	R	R
PE_13	R	CTOUT_14	I2C1_SDA	EMC_DQMOUT 3	GPIO7[13]	R	R	R
PE_14	R	R	R	EMC_DYCS3	GPIO7[14]	R	R	R
PE_15	R	CTOUT_0	I2C1_SCL	EMC_CKEOUT 3	GPIO7[15]	R	R	R
PF_0	SSP0_SCK	GP_CLKIN	R	R	R	R	R	I2S1_
PF_1	R	R	SSP0_SSEL	R	GPIO7[16]	R	R	R
PF_2	R	U3_TXD	SSP0_MISO	R	GPIO7[17]	R	R	R
PF_3	R	U3_RXD	SSP0_MOSI	R	GPIO7[18]	R	R	R
PF_4	SSP1_SCK	GP_CLKIN	TRACECLK	R	R	R	I2S0_TX_MCLK	I2S0_F
PF_5	R	U3_UCLK	SSP1_SSEL	TRACEDATA[0]	GPIO7[19]	R	R	R
PF_6	R	U3_DIR	SSP1_MISO	TRACEDATA[1]	GPIO7[20]	R	R	I2S1_
PF_7	R	U3_BAUD	SSP1_MOSI	TRACEDATA[2]	GPIO7[21]	R	R	I2S1_
PF_8	R	U0_UCLK	CTIN_2	TRACEDATA[3]	GPIO7[22]	R	R	R
PF_9	R	U0_DIR	CTOUT_1	R	GPIO7[23]	R	R	R
PF_10	R	U0_TXD	R	R	GPIO7[24]	R	SD_WP	R
PF_11	R	U0_RXD	R	R	GPIO7[25]	R	SD_VOLT2	R
CLK0	EMC_CLK0	CLKOUT	R	R	SD_CLK	EMC_CLK01	SSP1_SCK	ENET (ENET LK)

Table 172. Pin multiplexing

Pin name	MODE bits =							
	0	1	2	3	4	5	6	7
CLK1	EMC_CLK1	CLKOUT	R	R	R	CGU_OUT0	R	I2S1_7
CLK2	EMC_CLK3	CLKOUT	R	R	SD_CLK	EMC_CLK23	I2S0_TX_MCLK	I2S1_1
CLK3	EMC_CLK2	CLKOUT	R	R	R	CGU_OUT1	R	I2S1_1

[1] On parts with internal flash only.

16.4 Register description

The system control unit contains the registers to configure the pin function of multiplexed digital pins, the EMC clock delays, and the GPIO pin interrupts.

Remark: The boot loader configures the pins involved in the boot process (see [Table 16](#)) when the part starts up. The reset values given in [Table 173](#) for the pin configuration registers and EMC delay registers do not take into account the changes performed by the boot loader.

Table 173. Register overview: System Control Unit (SCU) (base address 0x4008 6000)

Name	Access	Address offset	Description	Reset value	Reset value after EMC boot	Reset value after UART boot	Reference
Pins P0_n							
SFSP0_0	R/W	0x000	Pin configuration register for pin P0_0	0x00	0x00	0x00	Table 174
SFSP0_1	R/W	0x004	Pin configuration register for pin P0_1	0x00	0x00	0x00	Table 174
-	-	0x008 - 0x07C	Reserved	-	-	-	-
Pins P1_n							
SFSP1_0	R/W	0x080	Pin configuration register for pin P1_0	0x00	0xD2	0x00	Table 174
SFSP1_1	R/W	0x084	Pin configuration register for pin P1_1	0x00	0xD2	0x00	Table 174
SFSP1_2	R/W	0x088	Pin configuration register for pin P1_2	0x00	0xD2	0x00	Table 174
SFSP1_3	R/W	0x08C	Pin configuration register for pin P1_3	0x00	0xD3	0x00	Table 174
SFSP1_4	R/W	0x090	Pin configuration register for pin P1_4	0x00	0xD3	0x00	Table 174
SFSP1_5	R/W	0x094	Pin configuration register for pin P1_5	0x00	0xD3	0x00	Table 174
SFSP1_6	R/W	0x098	Pin configuration register for pin P1_6	0x00	0xD3	0x00	Table 174
SFSP1_7	R/W	0x09C	Pin configuration register for pin P1_7	0x00	0xD3	0x00	Table 174
SFSP1_8	R/W	0x0A0	Pin configuration register for pin P1_8	0x00	0xD3	0x00	Table 174
SFSP1_9	R/W	0x0A4	Pin configuration register for pin P1_9	0x00	0xD3	0x00	Table 174
SFSP1_10	R/W	0x0A8	Pin configuration register for pin P1_10	0x00	0xD3	0x00	Table 174
SFSP1_11	R/W	0x0AC	Pin configuration register for pin P1_11	0x00	0xD3	0x00	Table 174
SFSP1_12	R/W	0x0B0	Pin configuration register for pin P1_12	0x00	0xD3	0x00	Table 174
SFSP1_13	R/W	0x0B4	Pin configuration register for pin P1_13	0x00	0xD3	0x00	Table 174
SFSP1_14	R/W	0x0B8	Pin configuration register for pin P1_14	0x00	0xD3	0x00	Table 174
SFSP1_15	R/W	0x0BC	Pin configuration register for pin P1_15	0x00	0x00	0x00	Table 174
SFSP1_16	R/W	0x0C0	Pin configuration register for pin P1_16	0x00	0x00	0x00	Table 174
SFSP1_17	R/W	0x0C4	Pin configuration register for pin P1_17	0x00	0x00	0x00	Table 175
SFSP1_18	R/W	0x0C8	Pin configuration register for pin P1_18	0x00	0x00	0x00	Table 174
SFSP1_19	R/W	0x0CC	Pin configuration register for pin P1_19	0x00	0x00	0x00	Table 174
SFSP1_20	R/W	0x0D0	Pin configuration register for pin P1_20	0x00	0x00	0x00	Table 174
-	-	0x0D4 - 0x0FC	Reserved	-	-	-	-

Table 173. Register overview: System Control Unit (SCU) (base address 0x4008 6000)

...continued

Name	Access	Address offset	Description	Reset value	Reset value after EMC boot	Reset value after UART boot	Reference
Pins P2_n							
SFSP2_0	R/W	0x100	Pin configuration register for pin P2_0	0x00	0xD8	0xD1 (UART0)	Table 174
SFSP2_1	R/W	0x104	Pin configuration register for pin P2_1	0x00	0xD2	0xD1 (UART0)	Table 174
SFSP2_2	R/W	0x108	Pin configuration register for pin P2_2	0x00	0xD2		Table 174
SFSP2_3	R/W	0x10C	Pin configuration register for pin P2_3	0x00	0x00	0xD2 (UART3)	Table 175
SFSP2_4	R/W	0x110	Pin configuration register for pin P2_4	0x00	0x00	0xD2 (UART3)	Table 175
SFSP2_5	R/W	0x114	Pin configuration register for pin P2_5	0x00	0x00	0x00	Table 175
SFSP2_6	R/W	0x118	Pin configuration register for pin P2_6	0x00	0xD2	0x00	Table 174
SFSP2_7	R/W	0x11C	Pin configuration register for pin P2_7	0x00	0xD3	0x00	Table 174
SFSP2_8	R/W	0x120	Pin configuration register for pin P2_8	0x00	0xD3	0x00	Table 174
SFSP2_9	R/W	0x124	Pin configuration register for pin P2_9	0x00	0xD3	0x00	Table 174
SFSP2_10	R/W	0x128	Pin configuration register for pin P2_10	0x00	0xD3	0x00	Table 174
SFSP2_11	R/W	0x12C	Pin configuration register for pin P2_11	0x00	0xD3	0x00	Table 174
SFSP2_12	R/W	0x130	Pin configuration register for pin P2_12	0x00	0xD3	0x00	Table 174
SFSP2_13	R/W	0x134	Pin configuration register for pin P2_13	0x00	0xD3	0x00	Table 174
-	-	0x138 - 0x17C	Reserved	-	-	-	-
Pins P3_n							
SFSP3_0	R/W	0x180	Pin configuration register for pin P3_0	0x00	0x00	0x00	Table 174
SFSP3_1	R/W	0x184	Pin configuration register for pin P3_1	0x00	0x00	0x00	Table 174
SFSP3_2	R/W	0x188	Pin configuration register for pin P3_2	0x00	0x00	0x00	Table 174
SFSP3_3	R/W	0x18C	Pin configuration register for pin P3_3	0x00	0x00	0x00	Table 176
SFSP3_4	R/W	0x190	Pin configuration register for pin P3_4	0x00	0x00	0x00	Table 174
SFSP3_5	R/W	0x194	Pin configuration register for pin P3_5	0x00	0x00	0x00	Table 174
SFSP3_6	R/W	0x198	Pin configuration register for pin P3_6	0x00	0x00	0x00	Table 174
SFSP3_7	R/W	0x19C	Pin configuration register for pin P3_7	0x00	0x00	0x00	Table 174
SFSP3_8	R/W	0x1A0	Pin configuration register for pin P3_8	0x00	0x00	0x00	Table 174
-	-	0x1A4 - 0x1FC	Reserved	-	-	-	-
Pins P4_n							
SFSP4_0	R/W	0x200	Pin configuration register for pin P4_0	0x00	0x00	0x00	Table 174
SFSP4_1	R/W	0x204	Pin configuration register for pin P4_1	0x00	0x00	0x00	Table 174/ Table 180
SFSP4_2	R/W	0x208	Pin configuration register for pin P4_2	0x00	0x00	0x00	Table 174

Table 173. Register overview: System Control Unit (SCU) (base address 0x4008 6000)

...continued

Name	Access	Address offset	Description	Reset value	Reset value after EMC boot	Reset value after UART boot	Reference
SFSP4_3	R/W	0x20C	Pin configuration register for pin P4_3	0x00	0x00	0x00	Table 174/ Table 180
SFSP4_4	R/W	0x210	Pin configuration register for pin P4_4	0x00	0x00	0x00	Table 174/ Table 184
SFSP4_5	R/W	0x214	Pin configuration register for pin P4_5	0x00	0x00	0x00	Table 174
SFSP4_6	R/W	0x218	Pin configuration register for pin P4_6	0x00	0x00	0x00	Table 174
SFSP4_7	R/W	0x21C	Pin configuration register for pin P4_7	0x00	0x00	0x00	Table 174
SFSP4_8	R/W	0x220	Pin configuration register for pin P4_8	0x00	0x00	0x00	Table 174
SFSP4_9	R/W	0x224	Pin configuration register for pin P4_9	0x00	0x00	0x00	Table 174
SFSP4_10	R/W	0x228	Pin configuration register for pin P4_10	0x00	0x00	0x00	Table 174
-	-	0x22C - 0x27C	Reserved	-	-	-	-
Pins P5_n							
SFSP5_0	R/W	0x280	Pin configuration register for pin P5_0	0x00	0xD2	0x00	Table 174
SFSP5_1	R/W	0x284	Pin configuration register for pin P5_1	0x00	0xD2	0x00	Table 174
SFSP5_2	R/W	0x288	Pin configuration register for pin P5_2	0x00	0xD2	0x00	Table 174
SFSP5_3	R/W	0x28C	Pin configuration register for pin P5_3	0x00	0xD2	0x00	Table 174
SFSP5_4	R/W	0x290	Pin configuration register for pin P5_4	0x00	0xD2	0x00	Table 174
SFSP5_5	R/W	0x294	Pin configuration register for pin P5_5	0x00	0xD2	0x00	Table 174
SFSP5_6	R/W	0x298	Pin configuration register for pin P5_6	0x00	0xD2	0x00	Table 174
SFSP5_7	R/W	0x29C	Pin configuration register for pin P5_7	0x00	0xD2	0x00	Table 174
-	-	0x2A0 - 0x2FC	Reserved	-	-	-	-
Pins P6_n							
SFSP6_0	R/W	0x300	Pin configuration register for pin P6_0	0x00	0x00	0x00	Table 174
SFSP6_1	R/W	0x304	Pin configuration register for pin P6_1	0x00	0x00	0x00	Table 174
SFSP6_2	R/W	0x308	Pin configuration register for pin P6_2	0x00	0x00	0x00	Table 174
SFSP6_3	R/W	0x30C	Pin configuration register for pin P6_3	0x00	0x00	0x00	Table 174
SFSP6_4	R/W	0x310	Pin configuration register for pin P6_4	0x00	0x00	0x00	Table 174
SFSP6_5	R/W	0x314	Pin configuration register for pin P6_5	0x00	0x00	0x00	Table 174
SFSP6_6	R/W	0x318	Pin configuration register for pin P6_6	0x00	0xD1	0x00	Table 174
SFSP6_7	R/W	0x31C	Pin configuration register for pin P6_7	0x00	0xD8	0x00	Table 174
SFSP6_8	R/W	0x320	Pin configuration register for pin P6_8	0x00	0xD8	0x00	Table 174
SFSP6_9	R/W	0x324	Pin configuration register for pin P6_9	0x00	0x00	0x00	Table 174
SFSP6_10	R/W	0x328	Pin configuration register for pin P6_10	0x00	0x00	0x00	Table 174
SFSP6_11	R/W	0x32C	Pin configuration register for pin P6_11	0x00	0x00	0x00	Table 174
SFSP6_12	R/W	0x330	Pin configuration register for pin P6_12	0x00	0x00	0x00	Table 174

Table 173. Register overview: System Control Unit (SCU) (base address 0x4008 6000)

...continued

Name	Access	Address offset	Description	Reset value	Reset value after EMC boot	Reset value after UART boot	Reference
-	-	0x334 - 0x37C	Reserved	-	-	-	-
Pins P7_n							
SFSP7_0	R/W	0x380	Pin configuration register for pin P7_0	0x00	0x00	0x00	Table 174
SFSP7_1	R/W	0x384	Pin configuration register for pin P7_1	0x00	0x00	0x00	Table 174
SFSP7_2	R/W	0x388	Pin configuration register for pin P7_2	0x00	0x00	0x00	Table 174
SFSP7_3	R/W	0x38C	Pin configuration register for pin P7_3	0x00	0x00	0x00	Table 174
SFSP7_4	R/W	0x390	Pin configuration register for pin P7_4	0x00	0x00	0x00	Table 174/ Table 180
SFSP7_5	R/W	0x394	Pin configuration register for pin P7_5	0x00	0x00	0x00	Table 174/ Table 180
SFSP7_6	R/W	0x398	Pin configuration register for pin P7_6	0x00	0x00	0x00	Table 174
SFSP7_7	R/W	0x39C	Pin configuration register for pin P7_7	0x00	0x00	0x00	Table 174/ Table 182
-	-	0x3A0 - 0x3FC	Reserved	-	-	-	-
Pins P8_n							
SFSP8_0	R/W	0x400	Pin configuration register for pin P8_0	0x00	0x00	0x00	Table 175
SFSP8_1	R/W	0x404	Pin configuration register for pin P8_1	0x00	0x00	0x00	Table 175
SFSP8_2	R/W	0x408	Pin configuration register for pin P8_2	0x00	0x00	0x00	Table 175
SFSP8_3	R/W	0x40C	Pin configuration register for pin P8_3	0x00	0x00	0x00	Table 174
SFSP8_4	R/W	0x410	Pin configuration register for pin P8_4	0x00	0x00	0x00	Table 174
SFSP8_5	R/W	0x414	Pin configuration register for pin P8_5	0x00	0x00	0x00	Table 174
SFSP8_6	R/W	0x418	Pin configuration register for pin P8_6	0x00	0x00	0x00	Table 174
SFSP8_7	R/W	0x41C	Pin configuration register for pin P8_7	0x00	0x00	0x00	Table 174
SFSP8_8	R/W	0x420	Pin configuration register for pin P8_8	0x00	0x00	0x00	Table 174
-	-	0x424 - 0x47C	Reserved	-	-	-	-
Pins P9_n							
SFSP9_0	R/W	0x480	Pin configuration register for pin P9_0	0x00	0x00	0x00	Table 174
SFSP9_1	R/W	0x484	Pin configuration register for pin P9_1	0x00	0x00	0x00	Table 174
SFSP9_2	R/W	0x488	Pin configuration register for pin P9_2	0x00	0x00	0x00	Table 174
SFSP9_3	R/W	0x49C	Pin configuration register for pin P9_3	0x00	0x00	0x00	Table 174
SFSP9_4	R/W	0x490	Pin configuration register for pin P9_4	0x00	0x00	0x00	Table 174
SFSP9_5	R/W	0x494	Pin configuration register for pin P9_5	0x00	0x00	0x00	Table 174
SFSP9_6	R/W	0x498	Pin configuration register for pin P9_6	0x00	0x00	0x00	Table 174
-	-	0x49C - 0x4FC	Reserved	-	-	-	-

Table 173. Register overview: System Control Unit (SCU) (base address 0x4008 6000)

...continued

Name	Access	Address offset	Description	Reset value	Reset value after EMC boot	Reset value after UART boot	Reference
Pins PA_n							
SFSPA_0	R/W	0x500	Pin configuration register for pin PA_0	0x00	0x00	0x00	Table 174
SFSPA_1	R/W	0x504	Pin configuration register for pin PA_1	0x00	0x00	0x00	Table 175
SFSPA_2	R/W	0x508	Pin configuration register for pin PA_2	0x00	0x00	0x00	Table 175
SFSPA_3	R/W	0x50C	Pin configuration register for pin PA_3	0x00	0x00	0x00	Table 175
SFSPA_4	R/W	0x510	Pin configuration register for pin PA_4	0x00	0xD8	0x00	Table 174
-	-	0x514 - 0x57C	Reserved	-	-	-	-
Pins PB_n							
SFSPB_0	R/W	0x580	Pin configuration register for pin PB_0	0x00	0x00	0x00	Table 174
SFSPB_1	R/W	0x584	Pin configuration register for pin PB_1	0x00	0x00	0x00	Table 174
SFSPB_2	R/W	0x588	Pin configuration register for pin PB_2	0x00	0x00	0x00	Table 174
SFSPB_3	R/W	0x58C	Pin configuration register for pin PB_3	0x00	0x00	0x00	Table 174
SFSPB_4	R/W	0x590	Pin configuration register for pin PB_4	0x00	0x00	0x00	Table 174
SFSPB_5	R/W	0x594	Pin configuration register for pin PB_5	0x00	0x00	0x00	Table 174
SFSPB_6	R/W	0x598	Pin configuration register for pin PB_6	0x00	0x00	0x00	Table 174/ Table 180
-	-	0x59C - 0x5FC	Reserved	-	-	-	-
Pins PC_n							
SFSPC_0	R/W	0x600	Pin configuration register for pin PC_0	0x00	0x00	0x00	Table 174/ Table 182
SFSPC_1	R/W	0x604	Pin configuration register for pin PC_1	0x00	0x00	0x00	Table 174
SFSPC_2	R/W	0x608	Pin configuration register for pin PC_2	0x00	0x00	0x00	Table 174
SFSPC_3	R/W	0x60C	Pin configuration register for pin PC_3	0x00	0x00	0x00	Table 174/ Table 182
SFSPC_4	R/W	0x610	Pin configuration register for pin PC_4	0x00	0x00	0x00	Table 174
SFSPC_5	R/W	0x614	Pin configuration register for pin PC_5	0x00	0x00	0x00	Table 174
SFSPC_6	R/W	0x618	Pin configuration register for pin PC_6	0x00	0x00	0x00	Table 174
SFSPC_7	R/W	0x61C	Pin configuration register for pin PC_7	0x00	0x00	0x00	Table 174
SFSPC_8	R/W	0x620	Pin configuration register for pin PC_8	0x00	0x00	0x00	Table 174
SFSPC_9	R/W	0x624	Pin configuration register for pin PC_9	0x00	0x00	0x00	Table 174
SFSPC_10	R/W	0x628	Pin configuration register for pin PC_10	0x00	0x00	0x00	Table 174
SFSPC_11	R/W	0x62C	Pin configuration register for pin PC_11	0x00	0x00	0x00	Table 174
SFSPC_12	R/W	0x630	Pin configuration register for pin PC_12	0x00	0x00	0x00	Table 174
SFSPC_13	R/W	0x634	Pin configuration register for pin PC_13	0x00	0x00	0x00	Table 174
SFSPC_14	R/W	0x638	Pin configuration register for pin PC_14	0x00	0x00	0x00	Table 174
-	-	0x63C - 0x67C	Reserved	-	-	-	-

Table 173. Register overview: System Control Unit (SCU) (base address 0x4008 6000)

...continued

Name	Access	Address offset	Description	Reset value	Reset value after EMC boot	Reset value after UART boot	Reference
Pins PD_n							
SFSPD_0	R/W	0x680	Pin configuration register for pin PD_0	0x00	0x00	0x00	Table 174
SFSPD_1	R/W	0x684	Pin configuration register for pin PD_1	0x00	0x00	0x00	Table 174
SFSPD_2	R/W	0x688	Pin configuration register for pin PD_2	0x00	0x00	0x00	Table 174
SFSPD_3	R/W	0x68C	Pin configuration register for pin PD_3	0x00	0x00	0x00	Table 174
SFSPD_4	R/W	0x690	Pin configuration register for pin PD_4	0x00	0x00	0x00	Table 174
SFSPD_5	R/W	0x694	Pin configuration register for pin PD_5	0x00	0x00	0x00	Table 174
SFSPD_6	R/W	0x698	Pin configuration register for pin PD_6	0x00	0x00	0x00	Table 174
SFSPD_7	R/W	0x69C	Pin configuration register for pin PD_7	0x00	0x00	0x00	Table 174
SFSPD_8	R/W	0x6A0	Pin configuration register for pin PD_8	0x00	0x00	0x00	Table 174
SFSPD_9	R/W	0x6A4	Pin configuration register for pin PD_9	0x00	0x00	0x00	Table 174
SFSPD_10	R/W	0x6A8	Pin configuration register for pin PD_10	0x00	0xD2	0x00	Table 174
SFSPD_11	R/W	0x6AC	Pin configuration register for pin PD_11	0x00	0x00	0x00	Table 174
SFSPD_12	R/W	0x6B0	Pin configuration register for pin PD_12	0x00	0x00	0x00	Table 174
SFSPD_13	R/W	0x6B4	Pin configuration register for pin PD_13	0x00	0xD2	0x00	Table 174
SFSPD_14	R/W	0x6B8	Pin configuration register for pin PD_14	0x00	0x00	0x00	Table 174
SFSPD_15	R/W	0x6BC	Pin configuration register for pin PD_15	0x00	0xD8	0x00	Table 174
SFSPD_16	R/W	0x6C0	Pin configuration register for pin PD_16	0x00	0xD8	0x00	Table 174
-	-	0x6C4 - 0x6FC	Reserved	-	-	-	
Pins PE_n							
SFSPE_0	R/W	0x700	Pin configuration register for pin PE_0	0x00	0xD8	0x00	Table 174
SFSPE_1	R/W	0x704	Pin configuration register for pin PE_1	0x00	0xD8	0x00	Table 174
SFSPE_2	R/W	0x708	Pin configuration register for pin PE_2	0x00	0xD8	0x00	Table 174
SFSPE_3	R/W	0x70C	Pin configuration register for pin PE_3	0x00	0xD8	0x00	Table 174
SFSPE_4	R/W	0x710	Pin configuration register for pin PE_4	0x00	0xD8	0x00	Table 174
SFSPE_5	R/W	0x714	Pin configuration register for pin PE_5	0x00	0x00	0x00	Table 174
SFSPE_6	R/W	0x718	Pin configuration register for pin PE_6	0x00	0x00	0x00	Table 174
SFSPE_7	R/W	0x71C	Pin configuration register for pin PE_7	0x00	0x00	0x00	Table 174
SFSPE_8	R/W	0x720	Pin configuration register for pin PE_8	0x00	0x00	0x00	Table 174
SFSPE_9	R/W	0x724	Pin configuration register for pin PE_9	0x00	0x00	0x00	Table 174
SFSPE_10	R/W	0x728	Pin configuration register for pin PE_10	0x00	0x00	0x00	Table 174
SFSPE_11	R/W	0x72C	Pin configuration register for pin PE_11	0x00	0x00	0x00	Table 174
SFSPE_12	R/W	0x730	Pin configuration register for pin PE_12	0x00	0x00	0x00	Table 174
SFSPE_13	R/W	0x734	Pin configuration register for pin PE_13	0x00	0x00	0x00	Table 174
SFSPE_14	R/W	0x738	Pin configuration register for pin PE_14	0x00	0x00	0x00	Table 174
SFSPE_15	R/W	0x73C	Pin configuration register for pin PE_15	0x00	0x00	0x00	Table 174

Table 173. Register overview: System Control Unit (SCU) (base address 0x4008 6000)

...continued

Name	Access	Address offset	Description	Reset value	Reset value after EMC boot	Reset value after UART boot	Reference
-	-	0x740 - 0x77C	Reserved	-	-	-	-
Pins PF_n							
SFSPF_0	R/W	0x780	Pin configuration register for pin PF_0	0x00	0x00	0x00	Table 174
SFSPF_1	R/W	0x784	Pin configuration register for pin PF_1	0x00	0x00	0x00	Table 174
SFSPF_2	R/W	0x788	Pin configuration register for pin PF_2	0x00	0x00	0x00	Table 174
SFSPF_3	R/W	0x78C	Pin configuration register for pin PF_3	0x00	0x00	0x00	Table 174
SFSPF_4	R/W	0x790	Pin configuration register for pin PF_4	0x00	0x00	0x00	Table 174
SFSPF_5	R/W	0x794	Pin configuration register for pin PF_5	0x00	0x00	0x00	Table 174/ Table 182
SFSPF_6	R/W	0x798	Pin configuration register for pin PF_6	0x00	0x00	0x00	Table 174/ Table 182
SFSPF_7	R/W	0x79C	Pin configuration register for pin PF_7	0x00	0x00	0x00	Table 174/ Table 182
SFSPF_8	R/W	0x7A0	Pin configuration register for pin PF_8	0x00	0x00	0x00	Table 174/ Table 180
SFSPF_9	R/W	0x7A4	Pin configuration register for pin PF_9	0x00	0x00	0x00	Table 174/ Table 182
SFSPF_10	R/W	0x7A8	Pin configuration register for pin PF_10	0x00	0x00	0x00	Table 174/ Table 180
SFSPF_11	R/W	0x7AC	Pin configuration register for pin PF_11	0x00	0x00	0x00	Table 174/ Table 182
-	-	0x7B0 - 0xBFC	Reserved	-	-	-	-
CLKn pins							
SFSClk0	R/W	0xC00	Pin configuration register for pin CLK0	0x00	0x00	0x00	Table 176
SFSClk1	R/W	0xC04	Pin configuration register for pin CLK1	0x00	0x00	0x00	Table 176
SFSClk2	R/W	0xC08	Pin configuration register for pin CLK2	0x00	0x00	0x00	Table 176
SFSClk3	R/W	0xC0C	Pin configuration register for pin CLK3	0x00	0x00	0x00	Table 176
-	-	0xC10 - 0xC7C	Reserved	-	-	-	-
USB1 USB1_DP/USB1_DM pins and I²C-bus open-drain pins							
SFSUSB	R/W	0xC80	Pin configuration register for pins USB1_DM and USB1_DP	0x02	0x00	0x00	Table 177
SFSI2C0	R/W	0xC84	Pin configuration register for I ² C0-bus pins	0x00	0x00	0x00	Table 178
ADC pin select registers							
ENAI00	R/W	0xC88	ADC0 function select register	0x00	0x00	0x00	Table 180
ENAI01	R/W	0xC8C	ADC1 function select register	0x00	0x00	0x00	Table 182
ENAI02	R/W	0xC90	Analog function select register	0x00	0x00	0x00	Table 184

Table 173. Register overview: System Control Unit (SCU) (base address 0x4008 6000)

...continued

Name	Access	Address offset	Description	Reset value	Reset value after EMC boot	Reset value after UART boot	Reference
EMC delay register							
EMCDELAYCLK	R/W	0xD00	EMC clock delay register	0x00	0x00	0x00	Table 185
SD/MMC delay register							
SDDELAY	R/W	0xD80	SD/MMC sample and drive delay register	0x00	0x00	0x00	Table 186
Pin interrupt select registers							
PINTSEL0	R/W	0xE00	Pin interrupt select register for pin interrupts 0 to 3.	0x00	0x00	0x00	Table 187
PINTSEL1	R/W	0xE04	Pin interrupt select register for pin interrupts 4 to 7.	0x00	0x00	0x00	Table 188

16.4.1 Pin configuration registers for normal-drive pins

Each digital pin and each clock pin on the LPC18xx have an associated pin configuration register which determines the pin's function and electrical characteristics. The assigned functions for each pin are listed in [Table 172](#).

The pin configuration registers for normal-drive pins control the following pins:

- P0_0 and P0_1
- P1_0 to P1_16 and P1_18 to P1_20
- P2_0 to P2_2 and P2_6 to P2_13
- P3_0 to P3_2 and P3_4 to P3_8
- P4_0 to P4_10
- P5_0 to P5_7
- P6_0 to P6_12
- P7_0 to P7_7
- P8_3 to P8_8
- P9_0 to P9_6
- PA_0 and PA_4
- PB_0 to PB_6
- PC_0 to PC_14
- PD_0 to PD_16
- PE_0 to PE_15
- PF_0 to PF_11

Table 174. Pin configuration registers for normal-drive pins (SFS, address 0x4008 6000 (SPSP0_0) to 0x4008 67AC (SFSPF_11)) bit description

Bit	Symbol	Value	Description	Reset value	Access
2:0	MODE		Select pin function.	0	R/W
		0x0	Function 0 (default)		
		0x1	Function 1		
		0x2	Function 2		
		0x3	Function 3		
		0x4	Function 4		
		0x5	Function 5		
		0x6	Function 6		
		0x7	Function 7		
3	EPD		Enable pull-down resistor at pad.	0	R/W
		0	Disable pull-down.		
		1	Enable pull-down. Enable both pull-down resistor and pull-up resistor for repeater mode.		
4	EPUN		Disable pull-up resistor at pad. By default, the pull-up resistor is enabled at reset.	0	R/W
		0	Enable pull-up. Enable both pull-down resistor and pull-up resistor for repeater mode.		
		1	Disable pull-up.		
5	EHS		Select Slew rate.	0	R/W
		0	Slow (low noise with medium speed)		
		1	Fast (medium noise with fast speed)		
6	EZI		Input buffer enable. The input buffer is disabled by default at reset and must be enabled for receiving.	0	R/W
		0	Disable input buffer		
		1	Enable input buffer		
7	ZIF		Input glitch filter. Disable the input glitch filter for clocking signals higher than 30 MHz.	0	R/W
		0	Enable input glitch filter		
		1	Disable input glitch filter		
31:8	-		Reserved	-	-

16.4.2 Pin configuration registers for high-drive pins

Each digital pin and each clock pin on the LPC18xx have an associated pin configuration register which determines the pin's function and electrical characteristics. The assigned functions for each pin are listed in [Table 172](#).

The pin configuration registers for high-drive pins control the following pins:

- P1_17
- P2_3 to P2_5

- P8_0 to P8_2
- PA_1 to PA_3

Table 175. Pin configuration registers for high-drive pins (SFS, address 0x4008 60C4 (SFSP1_17) to 0x4008 650C (SFSPA_3) bit description

Bit	Symbol	Value	Description	Reset value	Access
2:0	MODE		Select pin function.	0	R/W
		0x0	Function 0 (default)		
		0x1	Function 1		
		0x2	Function 2		
		0x3	Function 3		
		0x4	Function 4		
		0x5	Function 5		
		0x6	Function 6		
3	EPD		Enable pull-down resistor at pad.	0	R/W
		0	Disable pull-down.		
		1	Enable pull-down. Enable both pull-down resistor and pull-up resistor for repeater mode.		
4	EPUN		Disable pull-up resistor at pad. By default, the pull-up resistor is enabled at reset.	0	R/W
		0	Enable pull-up. Enable both pull-down resistor and pull-up resistor for repeater mode.		
		1	Disable pull-up.		
5	-		Reserved	-	-
6	EZI		Input buffer enable. The input buffer is disabled by default at reset but must be enabled to transfer data from the I/O buffer to the pad.	0	R/W
		0	Disable input buffer		
		1	Enable input buffer		
7	ZIF		Input glitch filter. Disable the input glitch filter for clocking signals higher than 30 MHz.	0	R/W
		0	Enable input glitch filter		
		1	Disable input glitch filter		
9:8	EHD		Select drive strength.	0	R/W
		0x0	Normal-drive: 4 mA drive strength		
		0x1	Medium-drive: 8 mA drive strength		
		0x2	High-drive: 14 mA drive strength		
		0x3	Ultra high-drive: 20 mA drive strength		
31:10	-		Reserved	-	-

16.4.3 Pin configuration registers for high-speed pins

Each digital pin and each clock pin on the LPC18xx have an associated pin configuration register which determines the pin's function and electrical characteristics. The assigned functions for each pin are listed in [Table 172](#).

This register controls the following pins: P3_3 and pins CLK0 to CLK3.

Table 176. Pin configuration registers for high-speed pins (SFS, address 0x4008 618C (SPSP3_3); 0x4008 6C00 (SFCLK0) to 0x4008 6C0C (SFCLK3)) bit description

Bit	Symbol	Value	Description	Reset value	Access
2:0	MODE		Select pin function.	0	R/W
		0x0	Function 0 (default)		
		0x1	Function 1		
		0x2	Function 2		
		0x3	Function 3		
		0x4	Function 4		
		0x5	Function 5		
		0x6	Function 6		
3	EPD		Enable pull-down resistor at pad.	0	R/W
		0	Disable pull-down.		
		1	Enable pull-down. Enable both pull-down resistor and pull-up resistor for repeater mode.		
4	EPUN		Disable pull-up resistor at pad. By default, the pull-up resistor is enabled at reset.	0	R/W
		0	Enable pull-up. Enable both pull-down resistor and pull-up resistor for repeater mode.		
		1	Disable pull-up.		
5	EHS		Slew rate	0	R/W
		0	Fast (low noise with fast speed)		
		1	High-speed (medium noise with high speed)		
6	EZI		Input buffer enable. The input buffer is disabled by default at reset and must be enabled for receiving.	0	R/W
		0	Disable input buffer		
		1	Enable input buffer		
7	ZIF		Input glitch filter. Disable the input glitch filter for clocking signals higher than 30 MHz.	0	R/W
		0	Enable input filter		
		1	Disable input filter		
31:8	-		Reserved	-	-

16.4.4 Pin configuration register for USB1 pins USB1_DP/USB1_DM

Remark: The USB_ESEA bit must be set to one to use USB1.

Table 177. Pin configuration for pins USB1_DP/USB1_DM register (SFSUSB, address 0x4008 6C80) bit description

Bit	Symbol	Value	Description	Reset value	Access
0	USB_AIM		Differential data input AIP/AIM.	0	R/W
		0	Going LOW with full speed edge rate		
		1	Going HIGH with full speed edge rate		
1	USB_ESEA		Control signal for differential input or single input.	1	R/W
		0	Reserved. Do not use.		
		1	Single input. Enables USB1. Use with the on-chip full-speed PHY.		
2	USB_EPD		Enable pull-down connect.	0	R/W
		0	Pull-down disconnected		
		1	Pull-down connected		
3	-		Reserved	-	-
4	USB_EPWR		Power mode.	0	R/W
		0	Power saving mode (Suspend mode)		
		1	Normal mode		
5	USB_VBUS		Enable the vbus_valid signal. This signal is monitored by the USB1 block. Use this bit for software de-bouncing of the VBUS sense signal or to indicate the VBUS state to the USB1 controller when the VBUS signal is present but the USB1_VBUS function is not connected in the SFSP2_5 register.	0	R/W
			Remark: The setting of this bit has no effect if the USB1_VBUS function of pin P2_5 is enabled through the SFSP2_5 register.		
		0	VBUS signal LOW or inactive		
		1	VBUS signal HIGH or active		
31:6	-		Reserved	-	-

16.4.5 Pin configuration register for open-drain I²C-bus pins

Table 178. Pin configuration for open-drain I²C-bus pins register (SFSI2C0, address 0x4008 6C84) bit description

Bit	Symbol	Value	Description	Reset value	Access
0	SCL_EFP		Select input glitch filter time constant for the SCL pin.	0	R/W
		0	50 ns glitch filter		
		1	3 ns glitch filter		
1	-		Reserved. Always write a 0 to this bit.	0	R/W
2	SCL_EHD		Select I2C mode for the SCL pin.	0	R/W
		0	Standard/Fast mode transmit		
		1	Fast-mode Plus transmit		

Table 178. Pin configuration for open-drain I²C-bus pins register (SFSI2C0, address 0x4008 6C84) bit description ...continued

Bit	Symbol	Value	Description	Reset value	Access
3	SCL_EZI		Enable the input receiver for the SCL pin. Always write a 1 to this bit when using the I2C0.	0	R/W
		0	Disabled		
		1	Enabled		
6:4	-		Reserved	-	-
7	SCL_ZIF		Enable or disable input glitch filter for the SCL pin. The filter time constant is determined by bit SCL_EFP.	0	R/W
		0	Enable input filter		
		1	Disable input filter		
8	SDA_EFP		Select input glitch filter time constant for the SDA pin.	0	R/W
		0	50 ns glitch filter		
		1	3 ns glitch filter		
9	-		Reserved. Always write a 0 to this bit.	0	R/W
10	SDA_EHD		Select I2C mode for the SDA pin.	0	R/W
		0	Standard/Fast mode transmit		
		1	Fast-mode Plus transmit		
11	SDA_EZI		Enable the input receiver for the SDA pin. Always write a 1 to this bit when using the I2C0.	0	R/W
		0	Disabled		
		1	Enabled		
14:12	-		Reserved	-	-
15	SDA_ZIF		Enable or disable input glitch filter for the SDA pin. The filter time constant is determined by bit SDA_EFP.	0	R/W
		0	Enable input filter		
		1	Disable input filter		
31:16	-		Reserved	-	-

16.4.6 ADC0 function select register

Remark: See [Section 16.1](#) for parts for which the ADC inputs are shared between the ADC0 and ADC1.

For pins with digital and analog functions, this register selects the input channel of the ADC0 over any of the possible digital functions. This option is not available for channel ADC0_7.

In addition, each analog function is pinned out on a dedicated analog pin which is not affected by this register.

The following pins are controlled by the ENAIO0 register:

Table 179. Pins controlled by the ENAIO0 register

Pin	ADC function	ENAIO0 register bit
P4_3	ADC0_0	0
P4_1	ADC0_1	1
PF_8	ADC0_2	2
P7_5	ADC0_3	3
P7_4	ADC0_4	4
PF_10	ADC0_5	5
PB_6	ADC0_6	6

By default, all pins are connected to their digital function 0 and only the digital pad is available.

To select the analog function, the pad must be set as follows using the corresponding SFSP register:

1. Tri-state the output driver by selecting an input at the pinmux e.g. GPIO function in input mode.
2. Disable the receiver by setting the EZI bit to zero (see [Table 174](#) or [Table 175](#)). This is the default setting.
3. Disable the pull-up resistor by setting the EPUN bit to one, and disable the pull-down resistor by setting the EPD bit to zero.
4. Set the bit corresponding to the analog function to 1 in the ENAIO0 register.

Table 180. ADC0 function select register (ENAIO0, address 0x4008 6C88) bit description

Bit	Symbol	Value	Description	Reset value	Access
0	ADC0_0		Select ADC0_0	0	R/W
		0	Digital function selected on pin P4_3.		
		1	Analog function ADC0_0 selected on pin P4_3		
1	ADC0_1		Select ADC0_1	0	R/W
		0	Digital function selected on pin P4_1.		
		1	Analog function ADC0_1 selected on pin P4_1.		
2	ADC0_2		Select ADC0_2	0	R/W
		0	Digital function selected on pin PF_8.		
		1	Analog function ADC0_2 selected on pin PF_8.		
3	ADC0_3		Select ADC0_3	0	R/W
		0	Digital function selected on pin P7_5.		
		1	Analog function ADC0_3 selected on pin P7_5.		
4	ADC0_4		Select ADC0_4	0	R/W
		0	Digital function selected on pin P7_4.		
		1	Analog function ADC0_4 selected on pin P7_4.		
5	ADC0_5		Select ADC0_5	0	R/W
		0	Digital function selected on pin PF_10.		
		1	Analog function ADC0_5 selected on pin PF_10.		

Table 180. ADC0 function select register (ENAI00, address 0x4008 6C88) bit description

Bit	Symbol	Value	Description	Reset value	Access
6	ADC0_6		Select ADC0_6	0	R/W
		0	Digital function selected on pin PB_6.		
		1	Analog function ADC0_6 selected on pin PB_6.		
31:7			Reserved	-	-

16.4.7 ADC1 function select register

Remark: See [Section 16.1](#) for parts for which the ADC inputs are shared between the ADC0 and ADC1.

For pins with digital and analog functions, this register selects the ADC1 function over any of the possible digital functions.

In addition, each analog function is pinned out on a dedicated analog pin which is not affected by this register.

The following pins are controlled by the ENAI01 register:

Table 181. Pins controlled by the ENAI01 register

Pin	ADC function	ENAI01 register bit
PC_3	ADC1_0	0
PC_0	ADC1_1	1
PF_9	ADC1_2	2
PF_6	ADC1_3	3
PF_5	ADC1_4	4
PF_11	ADC1_5	5
P7_7	ADC1_6	6
PF_7	ADC1_7	7

By default, all pins are connected to their digital function 0 and only the digital pad is available.

To select the analog function, the pad must be set as follows using the corresponding SFSP register:

1. Tri-state the output driver by selecting an input at the pinmux e.g. GPIO function in input mode.
2. Disable the receiver by setting the EZI bit to zero (see [Table 174](#) or [Table 175](#)). This is the default setting.
3. Disable the pull-up resistor by setting the EPUN bit to one, and disable the pull-down resistor by setting the EPD bit to zero.
4. Set the bit corresponding to the analog function to 1 in the ENAI01 register.

Table 182. ADC1 function select register (ENAI01, address 0x4008 6C8C) bit description

Bit	Symbol	Value	Description	Reset value	Access
0	ADC1_0		Select ADC1_0	0	R/W
		0	Digital function selected on pin PC_3.		
		1	Analog function ADC1_0 selected on pin PC_3.		
1	ADC1_1		Select ADC1_1	0	R/W
		0	Digital function selected on pin PC_0.		
		1	Analog function ADC1_1 selected on pin PC_0.		
2	ADC1_2		Select ADC1_2	0	R/W
		0	Digital function selected on pin PF_9.		
		1	Analog function ADC1_2 selected on pin PF_9.		
3	ADC1_3		Select ADC1_3	0	R/W
		0	Digital function selected on pin PF_6.		
		1	Analog function ADC1_3 selected on pin PF_6.		
4	ADC1_4		Select ADC1_4	0	R/W
		0	Digital function selected on pin PF_5.		
		1	Analog function ADC1_4 selected on pin PF_5.		
5	ADC1_5		Select ADC1_5	0	R/W
		0	Digital function selected on pin PF_11.		
		1	Analog function ADC1_5 selected on pin PF_11.		
6	ADC1_6		Select ADC1_6	0	R/W
		0	Digital function selected on pin P7_7.		
		1	Analog function ADC1_6 selected on pin P7_7.		
7	ADC1_7		Select ADC1_7.	0	R/W
		0	Digital function selected on pin PF_7.		
		1	Analog function ADC1_7 selected on pin PF_7.		
31:8			Reserved	-	-

16.4.8 Analog function select register

For pins which have digital and analog functions, this register selects the analog DAC and band gap function over any of the possible digital functions.

In addition, the DAC function is pinned out on a dedicated analog pin which is not affected by this register.

The following pins are controlled by the ENAI02 register:

Table 183. Pins controlled by the ENAI02 register

Pin	ADC function	ENAI02 register bit
P4_4	DAC	0
PF_7	BG (band gap output)	4

By default, all pins are connected to their digital function 0 and only the digital pad is available.

To select the analog function, the pad must be set as follows using the corresponding SFSP register:

1. Tri-state the output driver by selecting an input at the pinmux e.g. GPIO function in input mode.
2. Disable the receiver by setting the EZI bit to zero (see [Table 174](#) or [Table 175](#)). This is the default setting.
3. Disable the pull-up resistor by setting the EPUN bit to one, and disable the pull-down resistor by setting the EPD bit to zero.
4. Set the bit corresponding to the analog function to 1 in the ENAIO2 register.

Table 184. Analog function select register (ENAIO2, address 0x4008 6C90) bit description

Bit	Symbol	Value	Description	Reset value	Access
0	DAC		Select DAC	0	R/W
		0	Digital function selected on pin P4_4.		
		1	Analog function DAC selected on pin P4_4.		
3:1			Reserved	-	-
4	BG		Select band gap output. To measure the band gap, disable the pull-up on pin PF_7 and connect PF_7 to the digital pad. Do not use the digital pad nor the ADC1_7 on the board when measuring the band gap (see Section 16.4.8.1).	0	R/W
		0	Digital function selected on pin PF_7.		
		1	Band gap output selected for pin PF_7.		
31:5			Reserved	-	-

16.4.8.1 Measuring the band gap

To measure the band gap, set up the pin configuration and ADC function select registers for pin PF_7 as follows:

1. Disable the pull-up and the input buffer: Set register SFSPF_7 at 0x4008 679C to 0x10.
2. Connect the ADC1_7 input to the digital pad: Set register ENAIO1 at 0x4008 6C8C to 0x80.
3. Connect the band gap to the digital pad: Set register ENAIO2 at 0x4008 6C90 to 0x10.
4. Do not connect pin PF_7 on the board.

16.4.9 EMC clock delay register

This register provides a programmable delay for the EMC clock outputs. The delay for all EMC_CLKn clock outputs is the same and increases in approximately 0.5 ns steps from 0 (CLK_DELAY = 0 to 3.5 ns (CLK_DELAY = 0x7777). The exact values of the delays vary over temperature and processing.

Table 185. EMC clock delay register (EMCDELAYCLK, address 0x4008 6D00) bit description

Bit	Symbol	Description	Reset value	Access
15:0	CLK_DELAY	EMC_CLKn SDRAM clock output delay. 0x0 = no delay 0x1111 ≈ 0.5 ns delay 0x2222 ≈ 1.0 ns delay 0x3333 ≈ 1.5 ns delay 0x4444 ≈ 2.0 ns delay 0x5555 ≈ 2.5 ns delay 0x6666 ≈ 3.0 ns delay 0x7777 ≈ 3.5 ns delay	0	R/W
31: 16	-	Reserved. Do not write ones to reserved register bits.	-	-

16.4.10 SD/MMC delay register

This register provides a programmable delay for the SD/MMC sample and drive inputs and outputs. See the *LPC18xx data sheets* for recommended settings.

Typical setting for SD cards are SAMPLE_DELAY = 0x8 and DRV_DELAY = 0xF.

Remark: The values DRV_DELAY = 0 and DRV_DELAY = 1 are not allowed.

Table 186. SD/MMC delay register (SDDELAY, address 0x4008 6D80) bit description

Bit	Symbol	Description	Reset value	Access
3:0	SAMPLE_DELAY	SD/MMC sample delay. The delay value is SAMPLE_DELAY x 0.5 ns.	0	R/W
7:4	-	Reserved. Do not write ones to reserved register bits.	-	-
11:8	DRV_DELAY	SD/MMC drive delay. The delay value is DRV_DELAY x 0.5 ns. The values DRV_DELAY = 0 and DRV_DELAY = 1 are not allowed.	0	R/W
31: 12	-	Reserved. Do not write ones to reserved register bits.	-	-

16.4.11 Pin interrupt select register 0

This register selects one GPIO pin from all GPIO pins on all ports as the source for pin interrupts 0 to 3.

Example: For pin interrupt 1, INTPIN1 = 0xA and PORTSEL1 = 1 select GPIO pin GPIO1[10] located on pin P2_9 to generate an interrupt. Each pin interrupt must be enabled in the NVIC.

To enable each pin interrupt and configure its edge or level sensitivity, use the GPIO pin interrupt registers (see [Section 18.4.1](#)).

Table 187. Pin interrupt select register 0 (PINTSEL0, address 0x4008 6E00) bit description

Bit	Symbol	Value	Description	Reset value
4:0	INTPIN0		Pin interrupt 0: Select the pin number within the GPIO port selected by the PORTSEL0 bit in this register.	0
7:5	PORTSEL0		Pin interrupt 0: Select the port for the pin number to be selected in the INTPIN0 bits of this register.	0
		0x0	GPIO Port 0	
		0x1	GPIO Port 1	
		0x2	GPIO Port 2	
		0x3	GPIO Port 3	
		0x4	GPIO Port 4	
		0x5	GPIO Port 5	
		0x6	GPIO Port 6	
0x7	GPIO Port 7			
12:8	INTPIN1		Pin interrupt 1: Select the pin number within the GPIO port selected by the PORTSEL1 bit in this register.	0
15:13	PORTSEL1		Pin interrupt 1: Select the port for the pin number to be selected in the INTPIN1 bits of this register.	0
		0x0	GPIO Port 0	
		0x1	GPIO Port 1	
		0x2	GPIO Port 2	
		0x3	GPIO Port 3	
		0x4	GPIO Port 4	
		0x5	GPIO Port 5	
		0x6	GPIO Port 6	
0x7	GPIO Port 7			
20:16	INTPIN2		Pin interrupt 2: Select the pin number within the GPIO port selected by the PORTSEL2 bit in this register.	0
23:21	PORTSEL2		Pin interrupt 2: Select the port for the pin number to be selected in the INTPIN2 bits of this register.	0
		0x0	GPIO Port 0	
		0x1	GPIO Port 1	
		0x2	GPIO Port 2	
		0x3	GPIO Port 3	
		0x4	GPIO Port 4	
		0x5	GPIO Port 5	
		0x6	GPIO Port 6	
0x7	GPIO Port 7			
28:24	INTPIN3		Pin interrupt 3: Select the pin number within the GPIO port selected by the PORTSEL3 bit in this register.	0

Table 187. Pin interrupt select register 0 (PINTSEL0, address 0x4008 6E00) bit description

Bit	Symbol	Value	Description	Reset value
31:29	PORTSEL3		Pin interrupt 3: Select the port for the pin number to be selected in the INTPIN3 bits of this register.	0
		0x0	GPIO Port 0	
		0x1	GPIO Port 1	
		0x2	GPIO Port 2	
		0x3	GPIO Port 3	
		0x4	GPIO Port 4	
		0x5	GPIO Port 5	
		0x6	GPIO Port 6	
		0x7	GPIO Port 7	

16.4.12 Pin interrupt select register 1

This register selects one GPIO pin from all GPIO pins on all ports as the source for pin interrupts 4 to 7.

Example: For pin interrupt 4, INTPIN4 = 0xA and PORTSEL4 = 1 select GPIO pin GPIO1[10] located on pin P2_9 to generate an interrupt. Each pin interrupt must be enabled in the NVIC using interrupt slots 32 to 39.

To enable each pin interrupt and configure its edge or level sensitivity, use the GPIO pin interrupt registers (see [Section 18.4.1](#)).

Table 188. Pin interrupt select register 1 (PINTSEL1, address 0x4008 6E04) bit description

Bit	Symbol	Value	Description	Reset value
4:0	INTPIN4		Pin interrupt 4: Select the pin number within the GPIO port selected by the PORTSEL4 bit in this register.	0
7:5	PORTSEL4		Pin interrupt 4: Select the port for the pin number to be selected in the INTPIN4 bits of this register.	0
		0x0	GPIO Port 0	
		0x1	GPIO Port 1	
		0x2	GPIO Port 2	
		0x3	GPIO Port 3	
		0x4	GPIO Port 4	
		0x5	GPIO Port 5	
		0x6	GPIO Port 6	
		0x7	GPIO Port 7	
12:8	INTPIN5		Pin interrupt 5: Select the pin number within the GPIO port selected by the PORTSEL5 bit in this register.	0

Table 188. Pin interrupt select register 1 (PINTSEL1, address 0x4008 6E04) bit description

Bit	Symbol	Value	Description	Reset value
15:13	PORTSEL5		Pin interrupt 5: Select the port for the pin number to be selected in the INTPIN5 bits of this register.	0
		0x0	GPIO Port 0	
		0x1	GPIO Port 1	
		0x2	GPIO Port 2	
		0x3	GPIO Port 3	
		0x4	GPIO Port 4	
		0x5	GPIO Port 5	
		0x6	GPIO Port 6	
		0x7	GPIO Port 7	
20:16	INTPIN6		Pint interrupt 6: Select the pin number within the GPIO port selected by the PORTSEL6 bit in this register.	0
23:21	PORTSEL6		Pin interrupt 6: Select the port for the pin number to be selected in the INTPIN6 bits of this register.	0
		0x0	GPIO Port 0	
		0x1	GPIO Port 1	
		0x2	GPIO Port 2	
		0x3	GPIO Port 3	
		0x4	GPIO Port 4	
		0x5	GPIO Port 5	
		0x6	GPIO Port 6	
		0x7	GPIO Port 7	
28:24	INTPIN7		Pint interrupt 7: Select the pin number within the GPIO port selected by the PORTSEL7 bit in this register.	0
31:29	PORTSEL7		Pin interrupt 7: Select the port for the pin number to be selected in the INTPIN7 bits of this register.	0
		0x0	GPIO Port 0	
		0x1	GPIO Port 1	
		0x2	GPIO Port 2	
		0x3	GPIO Port 3	
		0x4	GPIO Port 4	
		0x5	GPIO Port 5	
		0x6	GPIO Port 6	
		0x7	GPIO Port 7	

17.1 How to read this chapter

The GIMA is identical for all parts.

17.2 Basic configuration

The GIMA is configured as follows:

- See [Table 189](#) for clocking and power control.
- The GIMA is reset by the BUS_RST (reset #8). Do not reset the GIMA during normal operation.
- The GIMA outputs are connected to the timer, SCT, ADC, and event router peripherals (see [Table 190](#)).
- To configure the GIMA inputs for the timers and SCT, set the CTOUTCTRL bit in CREG6 ([Section 10.4.9](#)). This bit controls whether the SCT outputs are ORed with the timer match outputs or whether the SCT outputs only are used.

Table 189. GIMA clocking and power control

	Base clock	Branch clock	Operating frequency
Clock to GIMA register interface	BASE_M3_CLK	CLK_M3_BUS	up to 180 MHz

17.3 General description

The Global Input Multiplexer Array (GIMA) internally connects events to various event triggered peripherals such as the ADCs, the SCT, or the timers.

Each output of the GIMA is connected to a peripheral function (for example, a timer capture input or an ADC conversion trigger input) and configured through one register, which selects the event triggers and configures the clock synchronization.

For example, an ADC conversion can be triggered on either an SCT output or a timer match output. To select the trigger event, use GIMA output 28 which is connected to the ADC0 and ADC1 start0 conversion inputs. The corresponding GIMA output register ADCSTART0_IN selects SCT output 15 or the match output 0 of timer 0 as conversion triggers (see [Table 190](#)).

17.3.1 GIMA event input selection

Events that can trigger a peripheral function (e.g. an ADC conversion or a timer capture) can be selected from the following sources:

- Timer capture pins
- SCT input pins
- Timer0/1/2/3 match outputs
- SCT outputs

- I2S0/1 MWS signal
- USART0/2/3 RX/TX active signal
- USB0/1 SOF signal

The following peripheral functions are connected to GIMA outputs:

- Timer0/1/2/3 capture inputs
- SCT inputs
- ADC0/1 start of conversion
- Event router events

[Figure 40](#) shows the peripherals which are connected through the GIMA. For details, see [Table 190](#).

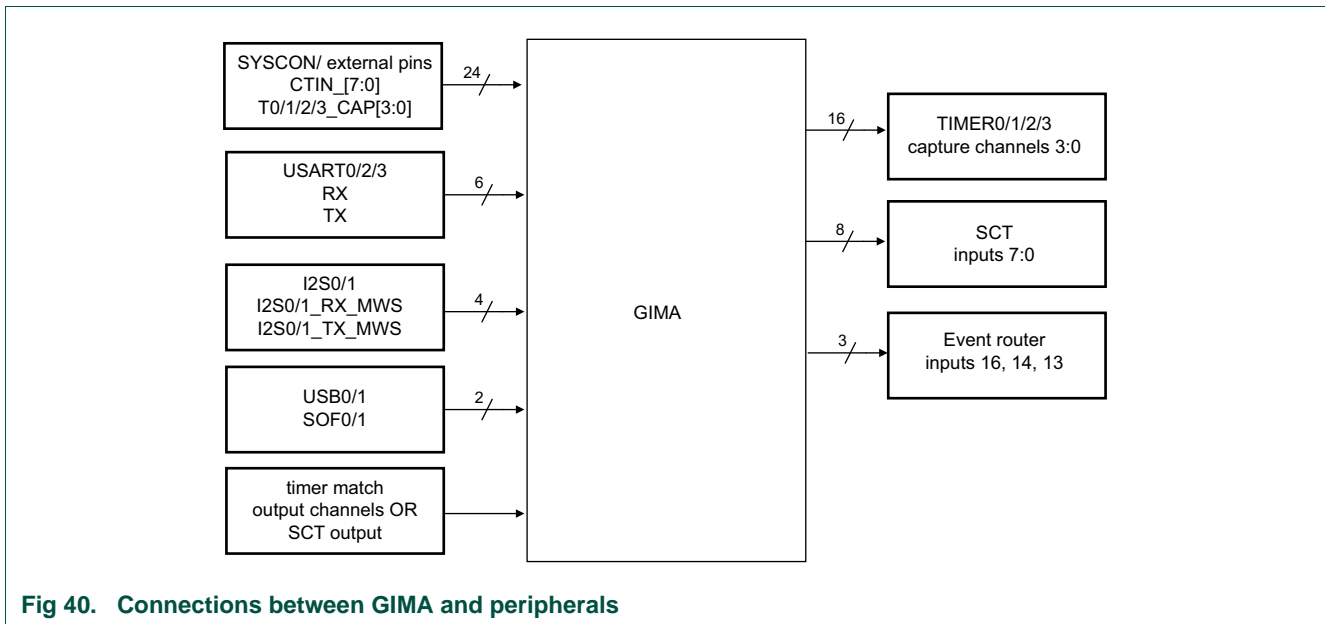

Fig 40. Connections between GIMA and peripherals

[Table 190](#) shows the GIMA output number, the peripheral function the GIMA output is connected to, and the events that can be selected for this GIMA output. For signals that originate from an external pin, select a pin from the pinout (more than one pins may be possible) and program the corresponding pin function in the pin configuration register. Inputs from external pins include any of the timer capture pins (T0/1/2/3_CAPx and SCT input pins CTIN_x).

Each GIMA output uses one register (see [Table 192](#)) to control the synchronization stage and to select an event from a subset of all available event trigger signals as shown in [Table 190](#).

Table 190. GIMA outputs

GIMA output	GIMA output connected to	GIMA inputs			Reference	
0	T0 capture channel 0	pin CTIN_0	Reserved	pin T0_CAP0	-	Table 193
1	T0 capture channel 1	pin CTIN_1	USART2 TX active	pin T0_CAP1	-	Table 194
2	T0 capture channel 2	pin CTIN_2	Reserved	pin T0_CAP2	-	Table 195
3	T0 capture channel 3	SCT output 15 or T3 match channel 3 ^[1]	pin T0_CAP3	T3 match channel 3	-	Table 196
4	T1 capture channel 0	pin CTIN_0	Reserved	pin T1_CAP0	-	Table 197
5	T1 capture channel 1	pin CTIN_3	USART0 TX active	pin T1_CAP1	-	Table 198
6	T1 capture channel 2	pin CTIN_4	USART0 RX active	pin T1_CAP2	-	Table 199
7	T1 capture channel 3	SCT output 3 or T0 match channel 3 ^[1]	pin T1_CAP3	T0 match channel 3	-	Table 200
8	T2 capture channel 0	pin CTIN_0	Reserved	pin T2_CAP0	-	Table 201
9	T2 capture channel 1	pin CTIN_1	USART2 TX active	I2S1_RX_MWS	pin T2_CAP1	Table 202
10	T2 capture channel 2	pin CTIN_5	USART2 RX active	I2S1_TX_MWS	pin T2_CAP2	Table 203
11	T2 capture channel 3	SCT output 7 or T1 match channel 3 ^[1]	pin T2_CAP3	-	-	Table 204
12	T3 capture channel 0	pin CTIN_0	I2S0_RX_MWS	pin T3_CAP0	-	Table 205
13	T3 capture channel 1	pin CTIN_6	USART3 TX active	I2S0_TX_MWS	pin T3_CAP1	Table 206
14	T3 capture channel 2	pin CTIN_7	USART3 RX active	SOF0	pin T3_CAP2	Table 207
15	T3 capture channel 3	SCT output 11 or T2 match channel 3 ^[1]	SOF1	pin T3_CAP3	-	Table 208
16	SCT input 0	pin CTIN_0	Reserved	Reserved	-	Table 209
17	SCT input 1	pin CTIN_1	USART2 TX active	Reserved	-	Table 210
18	SCT input 2	pin CTIN_2	Reserved	Reserved	-	Table 211
19	SCT input 3	pin CTIN_3	USART0 TX active	I2S1_RX_MWS	I2S1_TX_MWS	Table 212
20	SCT input 4	pin CTIN_4	USART0 RX active	I2S1_RX_MWS	I2S1_TX_MWS	Table 213
21	SCT input 5	pin CTIN_5	USART2 TX active	Reserved	-	Table 214
22	SCT input 6	pin CTIN_6	USART3 TX active	I2S0_RX_MWS	I2S0_TX_MWS	Table 215
23	SCT input 7	pin CTIN_7	USART3 RX active	SOF0	SOF1	Table 216
24	Reserved	-	-	-	-	-
25	Event router input 13	SCT output 2 or T0 match channel 2 ^[1]	Reserved	T0 match channel 2	-	Table 217

Table 190. GIMA outputs

GIMA output	GIMA output connected to	GIMA inputs				Reference
26	Event router input 14	SCT output 6 or T1 match channel 2 ^[1]	Reserved	T1 match channel 2	-	Table 218
27	Event router input 16	SCT output 14 or T3 match channel 2 ^[1]	T3 match channel 2	-	-	Table 219
28	ADC start0 input (ADC CR register START bits = 0x2)	SCT output 15 or T3 match channel 3 ^[1]	T0 match channel 0	-	-	Table 220
29	ADC start1 input (ADC CR register bit START = 0x3)	SCT output 8 or T2 match channel 0 ^[1]	T2 match channel 0	-	-	Table 221

[1] To configure the GIMA inputs for the timers and SCT, set the CTOUTCTRL bit in CREG6 ([Section 10.4.9](#)). This bit controls whether the SCT outputs are ORed with the timer match output or whether the SCT outputs only are considered.

17.3.2 GIMA clock synchronization

The clock synchronization control for each GIMA output consists of five stages ([Figure 41](#)):

1. Input selection
2. Input inversion: inverts the path between source and destination.
3. Asynchronous capture
4. Synchronization to peripheral clock
5. Pulse generation

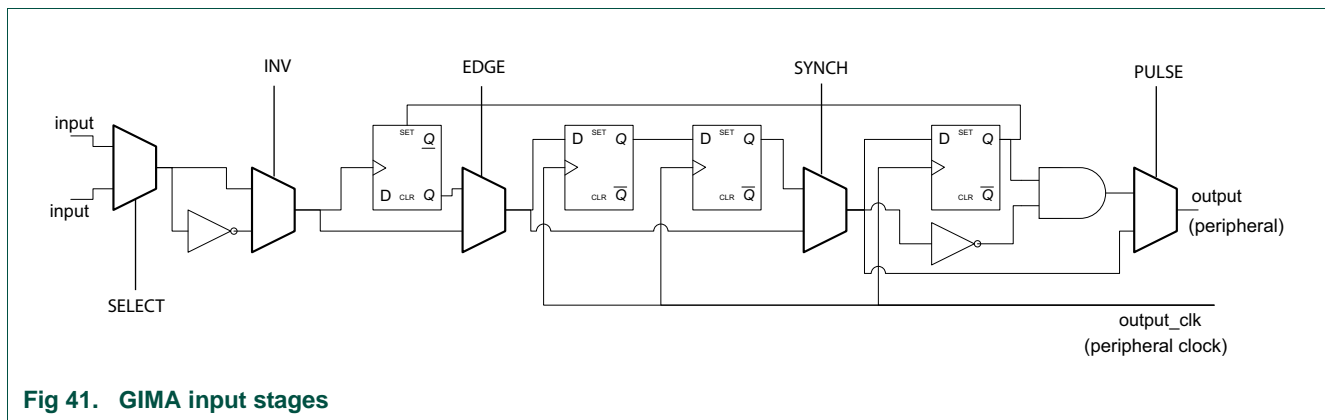

Fig 41. GIMA input stages

Once the input is selected for a GIMA output, the GIMA can synchronize the input signal (the source) to the branch clock of the peripheral to which the GIMA output connects (the target). For example, a signal from a pin can be synchronized to the timer branch clock if the pin is connected to the timer capture inputs through the GIMA. Even though the timers and the SCT have their own input synchronizer, the GIMA synchronizer can ensure that a high-frequency input signal is correctly captured by the timer peripheral and no pulses are missed.

The synchronization clocks are as follows:

- GIMA outputs 0 to 15: BASE_M3_CLK using the four timer branch clocks.

- GIMA outputs 16 to 23: BASE_M3_CLK using SCT branch clock.
- GIMA outputs 25 to 27: no synchronization clock required because the event router can capture a signal with edge or level sensitivity.
- GIMA outputs 28 to 29: BASE_APB3_CLK using the CLK_APB3_ADC0 branch clock for both outputs.

Enable synchronization through the GIMA in the following situations:

- Always enable synchronization for GIMA outputs ADC start0 input and start1 input. Both signals are synchronized to the ADC0 branch clock.
- When capturing a high-frequency input signal from a pin with the timer or SCT capture inputs.

When connecting timer and SCT signals internally through the GIMA, no synchronization is necessary because all timers use the BASE_M3_CLK as peripheral clock.

Table 191. Configuration options for the GIMA clock synchronization stages

GIMA output register setting			Description
EDGE (bit 1)	SYNCH (bit 2)	PULSE (bit 3)	
0	0	0	Asynchronous propagation of the signal from GIMA input to peripheral. Use this option when the peripheral can synchronize the input signal.
0	1	0	Synchronize GIMA input signal to peripheral branch clock. Frequency of the input signal (source) must be lower than frequency of the branch clock for the GIMA output (target).
0	1	1	Synchronize GIMA input signal to peripheral branch clock and create a single-cycle pulse of the branch clock for the GIMA output (target). Frequency of the input signal (source) must be lower than frequency of the branch clock for the GIMA output (target).
1	1	1	Convert clock pulses from a higher-frequency input (source) to clock pulses of the GIMA output branch (source) clock. In this mode, the GIMA output can capture a short pulse from the input. Note that the synchronization and clearing steps take a total of three clock cycles of the output branch clock.

17.4 Register description

Table 192. Register overview: GIMA (base address: 0x400C 7000)

Name	Access	Address offset	Description	Reset value	Reference
CAP0_0_IN	R/W	0x000	Timer 0 CAP0_0 capture input multiplexer (GIMA output 0)	0	Table 193
CAP0_1_IN	R/W	0x004	Timer 0 CAP0_1 capture input multiplexer (GIMA output 1)	0	Table 194
CAP0_2_IN	R/W	0x008	Timer 0 CAP0_2 capture input multiplexer (GIMA output 2)	0	Table 195

Table 192. Register overview: GIMA (base address: 0x400C 7000)

Name	Access	Address offset	Description	Reset value	Reference
CAP0_3_IN	R/W	0x00C	Timer 0 CAP0_3 capture input multiplexer (GIMA output 3)	0	Table 196
CAP1_0_IN	R/W	0x010	Timer 1 CAP1_0 capture input multiplexer (GIMA output 4)	0	Table 197
CAP1_1_IN	R/W	0x014	Timer 1 CAP1_1 capture input multiplexer (GIMA output 5)	0	Table 198
CAP1_2_IN	R/W	0x018	Timer 1 CAP1_2 capture input multiplexer (GIMA output 6)	0	Table 199
CAP1_3_IN	R/W	0x01C	Timer 1 CAP1_3 capture input multiplexer (GIMA output 7)	0	Table 200
CAP2_0_IN	R/W	0x020	Timer 2 CAP2_0 capture input multiplexer (GIMA output 8)	0	Table 201
CAP2_1_IN	R/W	0x024	Timer 2 CAP2_1 capture input multiplexer (GIMA output 9)	0	Table 202
CAP2_2_IN	R/W	0x028	Timer 2 CAP2_2 capture input multiplexer (GIMA output 10)	0	Table 203
CAP2_3_IN	R/W	0x02C	Timer 2 CAP2_3 capture input multiplexer (GIMA output 11)	0	Table 204
CAP3_0_IN	R/W	0x030	Timer 3 CAP3_0 capture input multiplexer (GIMA output 12)	0	Table 205
CAP3_1_IN	R/W	0x034	Timer 3 CAP3_1 capture input multiplexer (GIMA output 13)	0	Table 206
CAP3_2_IN	R/W	0x038	Timer 3 CAP3_2 capture input multiplexer (GIMA output 14)	0	Table 207
CAP3_3_IN	R/W	0x03C	Timer 3 CAP3_3 capture input multiplexer (GIMA output 15)	0	Table 208
CTIN_0_IN	R/W	0x040	SCT CTIN_0 capture input multiplexer (GIMA output 16)	0	Table 209
CTIN_1_IN	R/W	0x044	SCT CTIN_1 capture input multiplexer (GIMA output 17)	0	Table 210
CTIN_2_IN	R/W	0x048	SCT CTIN_2 capture input multiplexer (GIMA output 18)	0	Table 211
CTIN_3_IN	R/W	0x04C	SCT CTIN_3 capture input multiplexer (GIMA output 19)	0	Table 212
CTIN_4_IN	R/W	0x050	SCT CTIN_4 capture input multiplexer (GIMA output 20)	0	Table 213
CTIN_5_IN	R/W	0x054	SCT CTIN_5 capture input multiplexer (GIMA output 21)	0	Table 214
CTIN_6_IN	R/W	0x058	SCT CTIN_6 capture input multiplexer (GIMA output 22)	0	Table 215
CTIN_7_IN	R/W	0x05C	SCT CTIN_7 capture input multiplexer (GIMA output 23)	0	Table 216
-	-	0x060	Reserved	-	-
EVENTROUTER_13_IN	R/W	0x064	Event router input 13 multiplexer (GIMA output 25)	0	Table 217
EVENTROUTER_14_IN	R/W	0x068	Event router input 14 multiplexer (GIMA output 26)	0	Table 218

Table 192. Register overview: GIMA (base address: 0x400C 7000)

Name	Access	Address offset	Description	Reset value	Reference
EVENTROUTER_16_IN	R/W	0x06C	Event router input 16 multiplexer (GIMA output 27)	0	Table 219
ADCSTART0_IN	R/W	0x070	ADC0 and ADC1 start0 input multiplexer (GIMA output 28)	0	Table 220
ADCSTART1_IN	R/W	0x074	ADC0 and ADC1 start1 input multiplexer (GIMA output 29)	0	Table 221

17.4.1 Timer 0 CAP0_0 capture input multiplexer (CAP0_0_IN)

Table 193. Timer 0 CAP0_0 capture input multiplexer (CAP0_0_IN, address 0x400C 7000) bit description

Bit	Symbol	Value	Description	Reset value
0	INV		Invert input	0
		0	Not inverted.	
		1	Input inverted.	
1	EDGE		Enable rising edge detection	0
		0	No edge detection.	
		1	Rising edge detection enabled.	
2	SYNCH		Enable synchronization	0
		0	Disable synchronization.	
		1	Enable synchronization.	
3	PULSE		Enable single pulse generation.	0
		0	Disable single pulse generation.	
		1	Enable single pulse generation.	
7:4	SELECT		Select input. Values 0x3 to 0xF are reserved.	0
		0x0	CTIN_0	
		0x1	Reserved	
		0x2	T0_CAP0	
31:8	-		Reserved	-

17.4.2 Timer 0 CAP0_1 capture input multiplexer (CAP0_1_IN)

Table 194. Timer 0 CAP0_1 capture input multiplexer (CAP0_1_IN, address 0x400C 7004) bit description

Bit	Symbol	Value	Description	Reset value
0	INV		Invert input	0
		0	Not inverted.	
		1	Input inverted.	
1	EDGE		Enable rising edge detection	0
		0	No edge detection.	
		1	Rising edge detection enabled.	

Table 194. Timer 0 CAP0_1 capture input multiplexer (CAP0_1_IN, address 0x400C 7004) bit description

Bit	Symbol	Value	Description	Reset value
2	SYNCH		Enable synchronization	0
		0	Disable synchronization.	
		1	Enable synchronization.	
3	PULSE		Enable single pulse generation.	0
		0	Disable single pulse generation.	
		1	Enable single pulse generation.	
7:4	SELECT		Select input. Values 0x3 to 0xF are reserved.	0
		0x0	CTIN_1	
		0x1	USART2 TX active	
		0x2	T0_CAP1	
31:8	-		Reserved	-

17.4.3 Timer 0 CAP0_2 capture input multiplexer (CAP0_2_IN)

Table 195. Timer 0 CAP0_2 capture input multiplexer (CAP0_2_IN, address 0x400C 7008) bit description

Bit	Symbol	Value	Description	Reset value
0	INV		Invert input	0
		0	Not inverted.	
		1	Input inverted.	
1	EDGE		Enable rising edge detection	0
		0	No edge detection.	
		1	Rising edge detection enabled.	
2	SYNCH		Enable synchronization	0
		0	Disable synchronization.	
		1	Enable synchronization.	
3	PULSE		Enable single pulse generation.	0
		0	Disable single pulse generation.	
		1	Enable single pulse generation.	
7:4	SELECT		Select input. Values 0x3 to 0xF are reserved.	0
		0x0	CTIN_2	
		0x1	Reserved	
		0x2	T0_CAP2	
31:8	-		Reserved	-

17.4.4 Timer 0 CAP0_3 capture input multiplexer (CAP0_3_IN)

Table 196. Timer 0 CAP0_3 capture input multiplexer (CAP0_3_IN, address 0x400C 700C) bit description

Bit	Symbol	Value	Description	Reset value
0	INV		Invert input	0
		0	Not inverted.	
		1	Input inverted.	
1	EDGE		Enable rising edge detection	0
		0	No edge detection.	
		1	Rising edge detection enabled.	
2	SYNCH		Enable synchronization	0
		0	Disable synchronization.	
		1	Enable synchronization.	
3	PULSE		Enable single pulse generation.	0
		0	Disable single pulse generation.	
		1	Enable single pulse generation.	
7:4	SELECT		Select input. Values 0x3 to 0xF are reserved.	0
		0x0	CTOUT_15 or T3_MAT3	
		0x1	T0_CAP3	
		0x2	T3_MAT3	
31:8	-		Reserved	-

17.4.5 Timer 1 CAP1_0 capture input multiplexer (CAP1_0_IN)

Table 197. Timer 1 CAP1_0 capture input multiplexer (CAP1_0_IN, address 0x400C 7010) bit description

Bit	Symbol	Value	Description	Reset value
0	INV		Invert input	0
		0	Not inverted.	
		1	Input inverted.	
1	EDGE		Enable rising edge detection	0
		0	No edge detection.	
		1	Rising edge detection enabled.	
2	SYNCH		Enable synchronization	0
		0	Disable synchronization.	
		1	Enable synchronization.	
3	PULSE		Enable single pulse generation.	0
		0	Disable single pulse generation.	
		1	Enable single pulse generation.	

Table 197. Timer 1 CAP1_0 capture input multiplexer (CAP1_0_IN, address 0x400C 7010) bit description

Bit	Symbol	Value	Description	Reset value
7:4	SELECT		Select input. Values 0x3 to 0xF are reserved.	0
		0x0	CTIN_0	
		0x1	Reserved	
		0x2	T1_CAP0	
31:8	-		Reserved	-

17.4.6 Timer 1 CAP1_1 capture input multiplexer (CAP1_1_IN)

Table 198. Timer 1 CAP1_1 capture input multiplexer (CAP1_1_IN, address 0x400C 7014) bit description

Bit	Symbol	Value	Description	Reset value
0	INV		Invert input	0
		0	Not inverted.	
		1	Input inverted.	
1	EDGE		Enable rising edge detection	0
		0	No edge detection.	
	1	Rising edge detection enabled.		
2	SYNCH		Enable synchronization	0
		0	Disable synchronization.	
		1	Enable synchronization.	
3	PULSE		Enable single pulse generation.	0
		0	Disable single pulse generation.	
		1	Enable single pulse generation.	
7:4	SELECT		Select input. Values 0x3 to 0xF are reserved.	0
		0x0	CTIN_3	
		0x1	USART0 TX active	
		0x2	T1_CAP1	
31:8	-		Reserved	-

17.4.7 Timer 1 CAP1_2 capture input multiplexer (CAP1_2_IN)

Table 199. Timer 1 CAP1_2 capture input multiplexer (CAP1_2_IN, address 0x400C 7018) bit description

Bit	Symbol	Value	Description	Reset value
0	INV		Invert input	0
		0	Not inverted.	
		1	Input inverted.	
1	EDGE		Enable rising edge detection	0
		0	No edge detection.	
		1	Rising edge detection enabled.	

Table 199. Timer 1 CAP1_2 capture input multiplexer (CAP1_2_IN, address 0x400C 7018) bit description

Bit	Symbol	Value	Description	Reset value
2	SYNCH		Enable synchronization	0
		0	Disable synchronization.	
		1	Enable synchronization.	
3	PULSE		Enable single pulse generation.	0
		0	Disable single pulse generation.	
		1	Enable single pulse generation.	
7:4	SELECT		Select input. Values 0x3 to 0xF are reserved.	0
		0x0	CTIN_4	
		0x1	USART0 RX active	
		0x2	T1_CAP2	
31:8	-		Reserved	-

17.4.8 Timer 1 CAP1_3 capture input multiplexer (CAP1_3_IN)

Table 200. Timer 1 CAP1_3 capture input multiplexer (CAP1_3_IN, address 0x400C 701C) bit description

Bit	Symbol	Value	Description	Reset value
0	INV		Invert input	0
		0	Not inverted.	
		1	Input inverted.	
1	EDGE		Enable rising edge detection	0
		0	No edge detection.	
		1	Rising edge detection enabled.	
2	SYNCH		Enable synchronization	0
		0	Disable synchronization.	
		1	Enable synchronization.	
3	PULSE		Enable single pulse generation.	0
		0	Disable single pulse generation.	
		1	Enable single pulse generation.	
7:4	SELECT		Select input. Values 0x3 to 0xF are reserved.	0
		0x0	CTOUT_3 or T0_MAT3	
		0x1	T1_CAP3	
		0x2	T0_MAT3	
31:8	-		Reserved	-

17.4.9 Timer 2 CAP2_0 capture input multiplexer (CAP2_0_IN)

Table 201. Timer 2 CAP2_0 capture input multiplexer (CAP2_0_IN, address 0x400C 7020) bit description

Bit	Symbol	Value	Description	Reset value
0	INV		Invert input	0
		0	Not inverted.	
		1	Input inverted.	
1	EDGE		Enable rising edge detection	0
		0	No edge detection.	
		1	Rising edge detection enabled.	
2	SYNCH		Enable synchronization	0
		0	Disable synchronization.	
		1	Enable synchronization.	
3	PULSE		Enable single pulse generation.	0
		0	Disable single pulse generation.	
		1	Enable single pulse generation.	
7:4	SELECT		Select input. Values 0x4 to 0xF are reserved.	0
		0x0	CTIN_0	
		0x1	Reserved	
		0x2	T2_CAP0	
31:8	-		Reserved	-

17.4.10 Timer 2 CAP2_1 capture input multiplexer (CAP2_1_IN)

Table 202. Timer 2 CAP2_1 capture input multiplexer (CAP2_1_IN, address 0x400C 7024) bit description

Bit	Symbol	Value	Description	Reset value
0	INV		Invert input	0
		0	Not inverted.	
		1	Input inverted.	
1	EDGE		Enable rising edge detection	0
		0	No edge detection.	
		1	Rising edge detection enabled.	
2	SYNCH		Enable synchronization	0
		0	Disable synchronization.	
		1	Enable synchronization.	
3	PULSE		Enable single pulse generation.	0
		0	Disable single pulse generation.	
		1	Enable single pulse generation.	

Table 202. Timer 2 CAP2_1 capture input multiplexer (CAP2_1_IN, address 0x400C 7024) bit description

Bit	Symbol	Value	Description	Reset value
7:4	SELECT		Select input. Values 0x4 to 0xF are reserved.	0
		0x0	CTIN_1	
		0x1	USART2 TX active	
		0x2	I2S1_RX_MWS	
		0x3	T2_CAP1	
31:8	-		Reserved	-

17.4.11 Timer 2 CAP2_2 capture input multiplexer (CAP2_2_IN)

Table 203. Timer 2 CAP2_2 capture input multiplexer (CAP2_2_IN, address 0x400C 7028) bit description

Bit	Symbol	Value	Description	Reset value
0	INV		Invert input	0
		0	Not inverted.	
		1	Input inverted.	
1	EDGE		Enable rising edge detection	0
		0	No edge detection.	
		1	Rising edge detection enabled.	
2	SYNCH		Enable synchronization	0
		0	Disable synchronization.	
		1	Enable synchronization.	
3	PULSE		Enable single pulse generation.	0
		0	Disable single pulse generation.	
		1	Enable single pulse generation.	
7:4	SELECT		Select input. Values 0x4 to 0xF are reserved.	0
		0x0	CTIN_5	
		0x1	USART2 RX active	
		0x2	I2S1_TX_MWS	
		0x3	T2_CAP2	
31:8	-		Reserved	-

17.4.12 Timer 2 CAP2_3 capture input multiplexer (CAP2_3_IN)

Table 204. Timer 2 CAP2_3 capture input multiplexer (CAP2_3_IN, address 0x400C 702C) bit description

Bit	Symbol	Value	Description	Reset value
0	INV		Invert input	0
		0	Not inverted.	
		1	Input inverted.	

Table 204. Timer 2 CAP2_3 capture input multiplexer (CAP2_3_IN, address 0x400C 702C) bit description

Bit	Symbol	Value	Description	Reset value
1	EDGE		Enable rising edge detection	0
		0	No edge detection.	
		1	Rising edge detection enabled.	
2	SYNCH		Enable synchronization	0
		0	Disable synchronization.	
		1	Enable synchronization.	
3	PULSE		Enable single pulse generation.	0
		0	Disable single pulse generation.	
		1	Enable single pulse generation.	
7:4	SELECT		Select input. Values 0x3 to 0xF are reserved.	0
		0x0	CTOUT_7 or T1_MAT3	
		0x1	T2_CAP3	
		0x2	T1_MAT3	
31:8	-		Reserved	-

17.4.13 Timer 3 CAP3_0 capture input multiplexer (CAP3_0_IN)

Table 205. Timer 3 CAP3_0 capture input multiplexer (CAP3_0_IN, address 0x400C 7030) bit description

Bit	Symbol	Value	Description	Reset value
0	INV		Invert input	0
		0	Not inverted.	
		1	Input inverted.	
1	EDGE		Enable rising edge detection	0
		0	No edge detection.	
		1	Rising edge detection enabled.	
2	SYNCH		Enable synchronization	0
		0	Disable synchronization.	
		1	Enable synchronization.	
3	PULSE		Enable single pulse generation.	0
		0	Disable single pulse generation.	
		1	Enable single pulse generation.	
7:4	SELECT		Select input. Values 0x3 to 0xF are reserved.	0
		0x0	CTIN_0	
		0x1	I2S0_RX_MWS	
		0x2	T3_CAP0	
31:8	-		Reserved	-

17.4.14 Timer 3 CAP3_1 capture input multiplexer (CAP3_1_IN)

Table 206. Timer 3 CAP3_1 capture input multiplexer (CAP3_1_IN, address 0x400C 7034) bit description

Bit	Symbol	Value	Description	Reset value
0	INV		Invert input	0
		0	Not inverted.	
		1	Input inverted.	
1	EDGE		Enable rising edge detection	0
		0	No edge detection.	
		1	Rising edge detection enabled.	
2	SYNCH		Enable synchronization	0
		0	Disable synchronization.	
		1	Enable synchronization.	
3	PULSE		Enable single pulse generation.	0
		0	Disable single pulse generation.	
		1	Enable single pulse generation.	
7:4	SELECT		Select input. Values 0x4 to 0xF are reserved.	0
		0x0	CTIN_6	
		0x1	USART3 TX active	
		0x2	I2S0_TX_MWS	
		0x3	T3_CAP1	
31:8	-		Reserved	-

17.4.15 Timer 3 CAP3_2 capture input multiplexer (CAP3_2_IN)

Table 207. Timer 3 CAP3_2 capture input multiplexer (CAP3_2_IN, address 0x400C 7038) bit description

Bit	Symbol	Value	Description	Reset value
0	INV		Invert input	0
		0	Not inverted.	
		1	Input inverted.	
1	EDGE		Enable rising edge detection	0
		0	No edge detection.	
		1	Rising edge detection enabled.	
2	SYNCH		Enable synchronization	0
		0	Disable synchronization.	
		1	Enable synchronization.	
3	PULSE		Enable single pulse generation.	0
		0	Disable single pulse generation.	
		1	Enable single pulse generation.	

Table 207. Timer 3 CAP3_2 capture input multiplexer (CAP3_2_IN, address 0x400C 7038) bit description

Bit	Symbol	Value	Description	Reset value
7:4	SELECT		Select input. Values 0x4 to 0xF are reserved.	0
		0x0	CTIN_7	
		0x1	USART3 RX active	
		0x2	SOF0 (Start-Of-Frame USB0)	
		0x3	T3_CAP2	
31:8	-		Reserved	-

17.4.16 Timer 3 CAP3_3 capture input multiplexer (CAP3_3_IN)

Table 208. Timer 3 CAP3_3 capture input multiplexer (CAP3_3_IN, address 0x400C 703C) bit description

Bit	Symbol	Value	Description	Reset value
0	INV		Invert input	0
		0	Not inverted.	
		1	Input inverted.	
1	EDGE		Enable rising edge detection	0
		0	No edge detection.	
		1	Rising edge detection enabled.	
2	SYNCH		Enable synchronization	0
		0	Disable synchronization.	
		1	Enable synchronization.	
3	PULSE		Enable single pulse generation.	0
		0	Disable single pulse generation.	
		1	Enable single pulse generation.	
7:4	SELECT		Select input. Values 0x4 to 0xF are reserved.	0
		0x0	CTOUT11 or T2_MAT3	
		0x1	SOF1 (Start-Of-Frame USB1)	
		0x2	T3_CAP3	
		0x3	T2_MAT3	
31:8	-		Reserved	-

17.4.17 SCT CTIN_0 capture input multiplexer (CTIN_0_IN)

Table 209. SCT CTIN_0 capture input multiplexer (CTIN_0_IN, address 0x400C 7040) bit description

Bit	Symbol	Value	Description	Reset value
0	INV		Invert input	0
		0	Not inverted.	
		1	Input inverted.	

Table 209. SCT CTIN_0 capture input multiplexer (CTIN_0_IN, address 0x400C 7040) bit description

Bit	Symbol	Value	Description	Reset value
1	EDGE		Enable rising edge detection	0
		0	No edge detection.	
		1	Rising edge detection enabled.	
2	SYNCH		Enable synchronization	0
		0	Disable synchronization.	
		1	Enable synchronization.	
3	PULSE		Enable single pulse generation.	0
		0	Disable single pulse generation.	
		1	Enable single pulse generation.	
7:4	SELECT		Select input. Values 0x3 to 0xF are reserved.	0
		0x0	CTIN_0	
		0x1	Reserved	
		0x2	Reserved	
31:8	-		Reserved	-

17.4.18 SCT CTIN_1 capture input multiplexer (CTIN_1_IN)

Table 210. SCT CTIN_1 capture input multiplexer (CTIN_1_IN, address 0x400C 7044) bit description

Bit	Symbol	Value	Description	Reset value
0	INV		Invert input	0
		0	Not inverted.	
		1	Input inverted.	
1	EDGE		Enable rising edge detection	0
		0	No edge detection.	
		1	Rising edge detection enabled.	
2	SYNCH		Enable synchronization	0
		0	Disable synchronization.	
		1	Enable synchronization.	
3	PULSE		Enable single pulse generation.	0
		0	Disable single pulse generation.	
		1	Enable single pulse generation.	
7:4	SELECT		Select input. Values 0x3 to 0xF are reserved.	0
		0x0	CTIN_1	
		0x1	USART2 TX active	
		0x2	Reserved	
31:8	-		Reserved	-

17.4.19 SCT CTIN_2 capture input multiplexer (CTIN_2_IN)

Table 211. SCT CTIN_2 capture input multiplexer (CTIN_2_IN, address 0x400C 7048) bit description

Bit	Symbol	Value	Description	Reset value
0	INV		Invert input	0
		0	Not inverted.	
		1	Input inverted.	
1	EDGE		Enable rising edge detection	0
		0	No edge detection.	
		1	Rising edge detection enabled.	
2	SYNCH		Enable synchronization	0
		0	Disable synchronization.	
		1	Enable synchronization.	
3	PULSE		Enable single pulse generation.	0
		0	Disable single pulse generation.	
		1	Enable single pulse generation.	
7:4	SELECT		Select input. Values 0x3 to 0xF are reserved.	0
		0x0	CTIN_2	
		0x1	Reserved	
		0x2	Reserved	
31:8	-		Reserved	-

17.4.20 SCT CTIN_3 capture input multiplexer (CTIN_3_IN)

Table 212. SCT CTIN_3 capture input multiplexer (CTIN_3_IN, address 0x400C 704C) bit description

Bit	Symbol	Value	Description	Reset value
0	INV		Invert input	0
		0	Not inverted.	
		1	Input inverted.	
1	EDGE		Enable rising edge detection	0
		0	No edge detection.	
		1	Rising edge detection enabled.	
2	SYNCH		Enable synchronization	0
		0	Disable synchronization.	
		1	Enable synchronization.	
3	PULSE		Enable single pulse generation.	0
		0	Disable single pulse generation.	
		1	Enable single pulse generation.	

Table 212. SCT CTIN_3 capture input multiplexer (CTIN_3_IN, address 0x400C 704C) bit description

Bit	Symbol	Value	Description	Reset value
7:4	SELECT		Select input. Values 0x4 to 0xF are reserved.	0
		0x0	CTIN_3	
		0x1	USART0 TX active	
		0x2	I2S1_RX_MWS	
		0x3	I2S1_TX_MWS	
31:8	-		Reserved	-

17.4.21 SCT CTIN_4 capture input multiplexer (CTIN_4_IN)

Table 213. SCT CTIN_4 capture input multiplexer (CTIN_4_IN, address 0x400C 7050) bit description

Bit	Symbol	Value	Description	Reset value
0	INV		Invert input	0
		0	Not inverted.	
		1	Input inverted.	
1	EDGE		Enable rising edge detection	0
		0	No edge detection.	
		1	Rising edge detection enabled.	
2	SYNCH		Enable synchronization	0
		0	Disable synchronization.	
		1	Enable synchronization.	
3	PULSE		Enable single pulse generation.	0
		0	Disable single pulse generation.	
		1	Enable single pulse generation.	
7:4	SELECT		Select input. Values 0x4 to 0xF are reserved.	0
		0x0	CTIN_4	
		0x1	USART0 RX active	
		0x2	I2S1_RX_MWS	
		0x3	I2S1_TX_MWS	
31:8	-		Reserved	-

17.4.22 SCT CTIN_5 capture input multiplexer (CTIN_5_IN)

Table 214. SCT CTIN_5 capture input multiplexer (CTIN_5_IN, address 0x400C 7054) bit description

Bit	Symbol	Value	Description	Reset value
0	INV		Invert input	0
		0	Not inverted.	
		1	Input inverted.	
1	EDGE		Enable rising edge detection	0
		0	No edge detection.	
		1	Rising edge detection enabled.	

Table 214. SCT CTIN_5 capture input multiplexer (CTIN_5_IN, address 0x400C 7054) bit description

Bit	Symbol	Value	Description	Reset value
2	SYNCH		Enable synchronization	0
		0	Disable synchronization.	
		1	Enable synchronization.	
3	PULSE		Enable single pulse generation.	0
		0	Disable single pulse generation.	
		1	Enable single pulse generation.	
7:4	SELECT		Select input. Values 0x3 to 0xF are reserved.	0
		0x0	CTIN_5	
		0x1	USART2 RX active	
		0x2	Reserved	
31:8	-		Reserved	-

17.4.23 SCT CTIN_6 capture input multiplexer (CTIN_6_IN)

Table 215. SCT CTIN_6 capture input multiplexer (CTIN_6_IN, address 0x400C 7058) bit description

Bit	Symbol	Value	Description	Reset value
0	INV		Invert input	0
		0	Not inverted.	
		1	Input inverted.	
1	EDGE		Enable rising edge detection	0
		0	No edge detection.	
		1	Rising edge detection enabled.	
2	SYNCH		Enable synchronization	0
		0	Disable synchronization.	
		1	Enable synchronization.	
3	PULSE		Enable single pulse generation.	0
		0	Disable single pulse generation.	
		1	Enable single pulse generation.	
7:4	SELECT		Select input. Values 0x4 to 0xF are reserved.	0
		0x0	CTIN_6	
		0x1	USART3 TX active	
		0x2	I2S0_RX_MWS	
		0x3	I2S0_TX_MWS	
31:8	-		Reserved	-

17.4.24 SCT CTIN_7 capture input multiplexer (CTIN_7_IN)

Table 216. SCT CTIN_7 capture input multiplexer (CTIN_7_IN, address 0x400C 705C) bit description

Bit	Symbol	Value	Description	Reset value
0	INV		Invert input	0
		0	Not inverted.	
		1	Input inverted.	
1	EDGE		Enable rising edge detection	0
		0	No edge detection.	
		1	Rising edge detection enabled.	
2	SYNCH		Enable synchronization	0
		0	Disable synchronization.	
		1	Enable synchronization.	
3	PULSE		Enable single pulse generation.	0
		0	Disable single pulse generation.	
		1	Enable single pulse generation.	
7:4	SELECT		Select input. Values 0x4 to 0xF are reserved.	0
		0x0	CTIN_7	
		0x1	USART3 RX active	
		0x2	SOF0 (Start-Of-Frame USB0)	
		0x3	SOF1 (Start-Of-Frame USB1)	
31:8	-		Reserved	-

17.4.25 Event router input 13 multiplexer (EVENTROUTER_13_IN)

Table 217. Event router input 13 multiplexer (EVENTROUTER_13_IN, address 0x400C 7064) bit description

Bit	Symbol	Value	Description	Reset value
0	INV		Invert input	0
		0	Not inverted.	
		1	Input inverted.	
1	EDGE		Enable rising edge detection	0
		0	No edge detection.	
		1	Rising edge detection enabled.	
2	SYNCH		Enable synchronization	0
		0	Disable synchronization.	
		1	Enable synchronization.	
3	PULSE		Enable single pulse generation.	0
		0	Disable single pulse generation.	
		1	Enable single pulse generation.	

Table 217. Event router input 13 multiplexer (EVENTROUTER_13_IN, address 0x400C 7064) bit description

Bit	Symbol	Value	Description	Reset value
7:4	SELECT		Select input. Values 0x3 to 0xF are reserved.	0
		0x0	CTOUT_2 or T0_MAT2	
		0x1	Reserved	
		0x2	T0_MAT2	
31:8	-		Reserved	-

17.4.26 Event router input 14 multiplexer (EVENTROUTER_14_IN)

Table 218. Event router input 14 multiplexer (EVENTROUTER_14_IN, address 0x400C 7068) bit description

Bit	Symbol	Value	Description	Reset value
0	INV		Invert input	0
		0	Not inverted.	
		1	Input inverted.	
1	EDGE		Enable rising edge detection	0
		0	No edge detection.	
		1	Rising edge detection enabled.	
2	SYNCH		Enable synchronization	0
		0	Disable synchronization.	
		1	Enable synchronization.	
3	PULSE		Enable single pulse generation.	0
		0	Disable single pulse generation.	
		1	Enable single pulse generation.	
7:4	SELECT		Select input. Values 0x3 to 0xF are reserved.	0
		0x0	CTOUT_6 or T1_MAT2	
		0x1	Reserved	
		0x2	T1_MAT2	
31:8	-		Reserved	-

17.4.27 Event router input 16 multiplexer (EVENTROUTER_16_IN)

Table 219. Event router input 16 multiplexer (EVENTROUTER_16_IN, address 0x400C 706C) bit description

Bit	Symbol	Value	Description	Reset value
0	INV		Invert input	0
		0	Not inverted.	
		1	Input inverted.	
1	EDGE		Enable rising edge detection	0
		0	No edge detection.	
		1	Rising edge detection enabled.	

Table 219. Event router input 16multiplexer (EVENTROUTER_16_IN, address 0x400C 706C) bit description

Bit	Symbol	Value	Description	Reset value
2	SYNCH		Enable synchronization	0
		0	Disable synchronization.	
		1	Enable synchronization.	
3	PULSE		Enable single pulse generation.	0
		0	Disable single pulse generation.	
		1	Enable single pulse generation.	
7:4	SELECT		Select input. Values 0x2 to 0xF are reserved.	0
		0x0	CTOUT_14 or T3_MAT2	
		0x1	T3_MAT2	
31:8	-		Reserved	-

17.4.28 ADC start0 input multiplexer (ADCSTART0_IN)

Table 220. ADC start0 input multiplexer (ADCSTART0_IN, address 0x400C 7070) bit description

Bit	Symbol	Value	Description	Reset value
0	INV		Invert input	0
		0	Not inverted.	
		1	Input inverted.	
1	EDGE		Enable rising edge detection	0
		0	No edge detection.	
		1	Rising edge detection enabled.	
2	SYNCH		Enable synchronization	0
		0	Disable synchronization.	
		1	Enable synchronization.	
3	PULSE		Enable single pulse generation.	0
		0	Disable single pulse generation.	
		1	Enable single pulse generation.	
7:4	SELECT		Select input. Values 0x2 to 0xF are reserved.	0
		0x0	CTOUT_15 or T3_MAT3	
		0x1	T0_MAT0	
31:8	-		Reserved	-

17.4.29 ADC start1 input multiplexer (ADCSTART1_IN)

Table 221. ADC start1 input multiplexer (ADCSTART1_IN, address 0x400C 7074) bit description

Bit	Symbol	Value	Description	Reset value
0	INV		Invert input	0
		0	Not inverted.	
		1	Input inverted.	

Table 221. ADC start1 input multiplexer (ADCSTART1_IN, address 0x400C 7074) bit description

Bit	Symbol	Value	Description	Reset value
1	EDGE		Enable rising edge detection	0
		0	No edge detection.	
		1	Rising edge detection enabled.	
2	SYNCH		Enable synchronization	0
		0	Disable synchronization.	
		1	Enable synchronization.	
3	PULSE		Enable single pulse generation.	0
		0	Disable single pulse generation.	
		1	Enable single pulse generation.	
7:4	SELECT		Select input. Values 0x2 to 0xF are reserved.	0
		0x0	CTOUT_8 or T2_MAT0	
		0x1	T2_MAT0	
31:8	-		Reserved	-

18.1 How to read this chapter

All GPIO register bit descriptions refer to up to 31 pins on each GPIO port. Depending on the package type, not all pins are available, and the corresponding bits in the GPIO registers are reserved.

Table 222. GPIO pins for different pin packages

	LBGA256	TFBGA180	TFBGA100	LQFP208	LQFP144
GPIO Port 0	GPIO0[15:0]	GPIO0[15:0]	GPIO0[4:0]; GPIO0[15:6]	GPIO0[15:0]	GPIO0[15:0]
GPIO Port 1	GPIO1[15:0]	GPIO1[15:0]	GPIO1[15:0]	GPIO1[15:0]	GPIO1[15:0]
GPIO Port 2	GPIO2[15:0]	GPIO2[15:0]	-	GPIO2[15:0]	GPIO2[15:0]
GPIO Port 3	GPIO3[15:0]	GPIO3[15:0]	GPIO3[1:0]; GPIO3[5:3]; GPIO3[7]	GPIO3[15:0]	GPIO3[15:0]
GPIO Port 4	GPIO4[15:0]	GPIO4[15:0]	-	GPIO4[15:0]	GPIO4[11]
GPIO Port 5	GPIO5[26:0]	GPIO5[26:0]	GPIO5[11:0]	GPIO5[25:0]	GPIO5[16:0]; GPIO5[18]
GPIO Port 6	GPIO6[30:0]	GPIO6[26:25]; GPIO[30:28]	-	GPIO6[5:0]; GPIO6[30:20]	-
GPIO Port 7	GPIO7[25:0]	GPIO7[4:0]	-	GPIO7[10:0]; GPIO7[21:17]; GPIO7[25:23]	-

18.2 Basic configuration

The GPIO blocks share a common clock and reset connection and are configured as follows:

- See [Table 223](#) for clocking and power control.
- The GPIO is reset by a GPIO_RST (reset #28).
- All GPIO pins are set to input by default. To read the signal on the GPIO input, enable the input buffer in the SCU block for the corresponding pin (see [Table 174](#) to [Table 176](#)).
- For the pin interrupts, select up to 8 external interrupt pins from all GPIO port pins in the SCU (see [Table 187](#) and [Table 188](#)). The pin interrupts must be enabled in the NVIC (see [Table 71](#)).
- The GPIO group interrupts must be enabled in the NVIC (see [Table 71](#)).
- GPIO port registers can be accessed by the GPDMA as memory-to-memory transfer.

Table 223. GPIO clocking and power control

	Base clock	Branch clock	Operating frequency
GPIO, GPIO pin interrupt, GPIO group0 interrupt, GPIO group1 interrupt	BASE_M3_CLK	CLK_M3_GPIO	up to 180 MHz

18.3 Features

18.3.1 GPIO pin interrupt features

- Up to 8 pins can be selected from all GPIO pins as edge- or level-sensitive interrupt requests. Each request creates a separate interrupt in the NVIC.
- Edge-sensitive interrupt pins can interrupt on rising or falling edges or both.
- Level-sensitive interrupt pins can be HIGH- or LOW-active.

18.3.2 GPIO group interrupt features

- The inputs from any number of GPIO pins can be enabled to contribute to a combined group interrupt.
- The polarity of each input enabled for the group interrupt can be configured HIGH or LOW.
- Enabled interrupts can be logically combined through an OR or AND operation.
- Two group interrupts are supported to reflect two distinct interrupt patterns.
- The GPIO group interrupts can wake up the part from sleep mode.

18.3.3 GPIO port features

- GPIO pins can be configured as input or output by software.
- All GPIO pins default to inputs with interrupt disabled at reset.
- Pin registers allow pins to be sensed and set individually.

18.4 General description

The GPIO pins can be used in several ways to set pins as inputs or outputs and use the inputs as combinations of level and edge sensitive interrupts.

18.4.1 GPIO pin interrupts

From all available GPIO pins, up to eight pins can be selected in the system control block to serve as external interrupt pins (see [Table 187](#) and [Table 188](#)). The external interrupt pins are connected to eight individual interrupts in the NVIC and are created based on rising or falling edges or on the input level on the pin.

18.4.2 GPIO group interrupt

For each port/pin connected to one of the two the GPIO Grouped Interrupt blocks (GROUP0 and GROUP1), the GPIO grouped interrupt registers determine which pins are enabled to generate interrupts and what the active polarities of each of those inputs are.

The GPIO grouped interrupt registers also select whether the interrupt output will be level or edge triggered and whether it will be based on the OR or the AND of all of the enabled inputs.

When the designated pattern is detected on the selected input pins, the GPIO grouped interrupt block will generate an interrupt.

18.4.3 GPIO port

The GPIO port registers can be used to configure each GPIO pin as input or output and read the state of each pin if the pin is configured as input or set the state of each pin if the pin is configured as output.

18.5 Register description

The GPIO consists of the following blocks:

- The GPIO pin interrupts block at address 0x4008 7000. Registers in this block enable the up to 8 pin interrupts selected in the PINTSELn registers (see [Table 187](#) or [Table 188](#)) and configure the level and edge sensitivity for each selected pin interrupt. The GPIO interrupt registers are listed in [Table 228](#) to [Table 237](#).
- The GPIO GROUP0 interrupt block at address 0x4008 8000. Registers in this block allow to configure any pin on port 0 and 1 to contribute to a combined interrupt. The GPIO GROUP0 registers are listed in [Table 225](#) and [Section 18.5.2](#).
- The GPIO GROUP1 interrupt block at address 0x4008 9000. Registers in this block allow to configure any pin on port 0 and 1 to contribute to a combined interrupt. The GPIO GROUP1 registers are listed in [Table 226](#) and [Section 18.5.2](#).
- The GPIO port block at address 0x400F 4000. Registers in this block allow to read and write to port pins and configure port pins as inputs or outputs. The GPIO port registers are listed in [Table 227](#) and [Section 18.5.3](#).

Note: In all GPIO registers, bits that are not shown are **reserved**.

Table 224. Register overview: GPIO pin interrupts (base address: 0x4008 7000)

Name	Access	Address offset	Description	Reset value	Reference
ISEL	R/W	0x000	Pin Interrupt Mode register	0	Table 228
IENR	R/W	0x004	Pin interrupt level (rising edge) interrupt enable register	0	Table 229
SIENR	WO	0x008	Pin interrupt level (rising edge) interrupt set register	NA	Table 230
CIENR	WO	0x00C	Pin interrupt level (rising edge interrupt) clear register	NA	Table 231
IENF	R/W	0x010	Pin interrupt active level (falling edge) interrupt enable register	0	Table 232
SIENF	WO	0x014	Pin interrupt active level (falling edge) interrupt set register	NA	Table 233
CIENF	WO	0x018	Pin interrupt active level (falling edge) interrupt clear register	NA	Table 234
RISE	R/W	0x01C	Pin interrupt rising edge register	0	Table 235
FALL	R/W	0x020	Pin interrupt falling edge register	0	Table 236
IST	R/W	0x024	Pin interrupt status register	0	Table 237

Table 225. Register overview: GPIO GROUP0 interrupt (base address 0x4008 8000)

Name	Access	Address offset	Description	Reset value	Reference
CTRL	R/W	0x000	GPIO grouped interrupt control register	0	Table 238
PORT_POL0	R/W	0x020	GPIO grouped interrupt port 0 polarity register	0xFFFF FFFF	Table 239
PORT_POL1	R/W	0x024	GPIO grouped interrupt port 1 polarity register	0xFFFF FFFF	Table 239
PORT_POL2	R/W	0x028	GPIO grouped interrupt port 2 polarity register	0xFFFF FFFF	Table 239
PORT_POL3	R/W	0x02C	GPIO grouped interrupt port 3 polarity register	0xFFFF FFFF	Table 239
PORT_POL4	R/W	0x030	GPIO grouped interrupt port 4 polarity register	0xFFFF FFFF	Table 239
PORT_POL5	R/W	0x034	GPIO grouped interrupt port 5 polarity register	0xFFFF FFFF	Table 239
PORT_POL6	R/W	0x038	GPIO grouped interrupt port 6 polarity register	0xFFFF FFFF	Table 239
PORT_POL7	R/W	0x03C	GPIO grouped interrupt port 7 polarity register	0xFFFF FFFF	Table 239
PORT_ENA0	R/W	0x040	GPIO grouped interrupt port 0 enable register	0	Table 240
PORT_ENA1	R/W	0x044	GPIO grouped interrupt port 1 enable register	0	Table 240
PORT_ENA2	R/W	0x048	GPIO grouped interrupt port 2 enable register	0	Table 240
PORT_ENA3	R/W	0x04C	GPIO grouped interrupt port 3 enable register	0	Table 240
PORT_ENA4	R/W	0x050	GPIO grouped interrupt port 4 enable register	0	Table 240
PORT_ENA5	R/W	0x054	GPIO grouped interrupt port 5 enable register	0	Table 240
PORT_ENA6	R/W	0x058	GPIO grouped interrupt port 5 enable register	0	Table 240
PORT_ENA7	R/W	0x05C	GPIO grouped interrupt port 5 enable register	0	Table 240

Table 226. Register overview: GPIO GROUP1 interrupt (base address 0x4008 9000)

Name	Access	Address offset	Description	Reset value	Reference
CTRL	R/W	0x000	GPIO grouped interrupt control register	0	Table 238
PORT_POL0	R/W	0x020	GPIO grouped interrupt port 0 polarity register	0xFFFF FFFF	Table 239
PORT_POL1	R/W	0x024	GPIO grouped interrupt port 1 polarity register	0xFFFF FFFF	Table 239
PORT_POL2	R/W	0x028	GPIO grouped interrupt port 2 polarity register	0xFFFF FFFF	Table 239
PORT_POL3	R/W	0x02C	GPIO grouped interrupt port 3 polarity register	0xFFFF FFFF	Table 239
PORT_POL4	R/W	0x030	GPIO grouped interrupt port 4 polarity register	0xFFFF FFFF	Table 239
PORT_POL5	R/W	0x034	GPIO grouped interrupt port 5 polarity register	0xFFFF FFFF	Table 239
PORT_POL6	R/W	0x038	GPIO grouped interrupt port 6 polarity register	0xFFFF FFFF	Table 239
PORT_POL7	R/W	0x03C	GPIO grouped interrupt port 7 polarity register	0xFFFF FFFF	Table 239
PORT_ENA0	R/W	0x040	GPIO grouped interrupt port 0 enable register	0	Table 240
PORT_ENA1	R/W	0x044	GPIO grouped interrupt port 1 enable register	0	Table 240
PORT_ENA2	R/W	0x048	GPIO grouped interrupt port 2 enable register	0	Table 240
PORT_ENA3	R/W	0x04C	GPIO grouped interrupt port 3 enable register	0	Table 240
PORT_ENA4	R/W	0x050	GPIO grouped interrupt port 4 enable register	0	Table 240
PORT_ENA5	R/W	0x054	GPIO grouped interrupt port 5 enable register	0	Table 240
PORT_ENA6	R/W	0x058	GPIO grouped interrupt port 5 enable register	0	Table 240
PORT_ENA7	R/W	0x05C	GPIO grouped interrupt port 5 enable register	0	Table 240

GPIO port addresses can be read and written as bytes, halfwords, or words.

Table 227. Register overview: GPIO port (base address 0x400F 4000)

The highest pin number on each port depends on package size (see [Table 222](#)).

Name	Access	Address offset	Description	Reset value	Width	Reference
B0 to B31	R/W	0x000 to 0x01F	Byte pin registers port 0; pins GPIO0[0] to GPIO0[31]	ext ^[1]	byte (8 bit)	Table 241
B32 to B63	R/W	0x020 to 0x03F	Byte pin registers port 1; pins GPIO1[0] to GPIO1[31]	ext ^[1]	byte (8 bit)	Table 241
B64 to B95	R/W	0x040 to 0x05F	Byte pin registers port 2; pins GPIO2[0] to GPIO2[31]	ext ^[1]	byte (8 bit)	
B96 to B127	R/W	0x060 to 0x07F	Byte pin registers port 3; pins GPIO3[0] to GPIO3[31]	ext ^[1]	byte (8 bit)	Table 241
B128 to B159	R/W	0x080 to 0x09F	Byte pin registers port 4; pins GPIO4[0] to GPIO4[31]	ext ^[1]	byte (8 bit)	Table 241
B160 to B191	R/W	0x0A0 to 0x0BF	Byte pin registers port 5; pins GPIO5[0] to GPIO5[31]	ext ^[1]	byte (8 bit)	Table 241
B192 to B223	R/W	0x0C0 to 0x0DF	Byte pin registers port 6; pins GPIO6[0] to GPIO6[31]	ext ^[1]	byte (8 bit)	Table 241
B224 to B255	R/W	0x0E0 to 0x0FF	Byte pin registers port 7; pins GPIO7[0] to GPIO7[31]	ext ^[1]	byte (8 bit)	Table 241
W0 to W31	R/W	0x1000 to 0x107C	Word pin registers port 0; pins GPIO0[0] to GPIO0[31]	ext ^[1]	word (32 bit)	Table 242
W32 to W63	R/W	0x1080 to 0x10FC	Word pin registers port 1; pins GPIO1[0] to GPIO1[31]	ext ^[1]	word (32 bit)	Table 242
W64 to W95	R/W	0x1100 to 0x11FC	Word pin registers port 2; pins GPIO2[0] to GPIO2[31]	ext ^[1]	word (32 bit)	Table 242
W96 to W127	R/W	0x1180 to 0x11FC	Word pin registers port 3; pins GPIO3[0] to GPIO3[31]	ext ^[1]	word (32 bit)	Table 242
W128 to W159	R/W	0x1200 to 0x12FC	Word pin registers port 4; pins GPIO4[0] to GPIO4[31]	ext ^[1]	word (32 bit)	Table 242
W160 to W191	R/W	0x1280 to 0x12FC	Word pin registers port 5; pins GPIO5[0] to GPIO5[31]	ext ^[1]	word (32 bit)	Table 242
W192 to W223	R/W	0x1300 to 0x137C	Word pin registers port 6; pins GPIO6[0] to GPIO6[31]	ext ^[1]	word (32 bit)	Table 242
W224 to W255	R/W	0x1380 to 0x13FC	Word pin registers port 7; pins GPIO7[0] to GPIO7[31]	ext ^[1]	word (32 bit)	Table 242
DIR0	R/W	0x2000	Direction registers port 0	0	word (32 bit)	Table 243
DIR1	R/W	0x2004	Direction registers port 1	0	word (32 bit)	Table 243
DIR2	R/W	0x2008	Direction registers port 2	0	word (32 bit)	Table 243
DIR3	R/W	0x200C	Direction registers port 3	0	word (32 bit)	Table 243
DIR4	R/W	0x2010	Direction registers port 4	0	word (32 bit)	Table 243
DIR5	R/W	0x2014	Direction registers port 5	0	word (32 bit)	Table 243
DIR6	R/W	0x2018	Direction registers port 6	0	word (32 bit)	Table 243
DIR7	R/W	0x201C	Direction registers port 7	0	word (32 bit)	Table 243
MASK0	R/W	0x2080	Mask register port 0	0	word (32 bit)	Table 244
MASK1	R/W	0x2084	Mask register port 1	0	word (32 bit)	Table 244
MASK2	R/W	0x2088	Mask register port 2	0	word (32 bit)	Table 244

Table 227. Register overview: GPIO port (base address 0x400F 4000)

The highest pin number on each port depends on package size (see [Table 222](#)).

Name	Access	Address offset	Description	Reset value	Width	Reference
MASK3	R/W	0x208C	Mask register port 3	0	word (32 bit)	Table 244
MASK4	R/W	0x2090	Mask register port 4	0	word (32 bit)	Table 244
MASK5	R/W	0x2094	Mask register port 5	0	word (32 bit)	Table 244
MASK6	R/W	0x2098	Mask register port 6	0	word (32 bit)	Table 244
MASK7	R/W	0x209C	Mask register port 7	0	word (32 bit)	Table 244
PIN0	R/W	0x2100	Port pin register port 0	ext ^[1]	word (32 bit)	Table 245
PIN1	R/W	0x2104	Port pin register port 1	ext ^[1]	word (32 bit)	Table 245
PIN2	R/W	0x2108	Port pin register port 2	ext ^[1]	word (32 bit)	Table 245
PIN3	R/W	0x210C	Port pin register port 3	ext ^[1]	word (32 bit)	Table 245
PIN4	R/W	0x2110	Port pin register port 4	ext ^[1]	word (32 bit)	Table 245
PIN5	R/W	0x2114	Port pin register port 5	ext ^[1]	word (32 bit)	Table 245
PIN6	R/W	0x2118	Port pin register port 6	ext ^[1]	word (32 bit)	Table 245
PIN7	R/W	0x211C	Port pin register port 7	ext ^[1]	word (32 bit)	Table 245
MPIN0	R/W	0x2180	Masked port register port 0	ext ^[1]	word (32 bit)	Table 246
MPIN1	R/W	0x2184	Masked port register port 1	ext ^[1]	word (32 bit)	Table 246
MPIN2	R/W	0x2188	Masked port register port 2	ext ^[1]	word (32 bit)	Table 246
MPIN3	R/W	0x218C	Masked port register port 3	ext ^[1]	word (32 bit)	Table 246
MPIN4	R/W	0x2190	Masked port register port 4	ext ^[1]	word (32 bit)	Table 246
MPIN5	R/W	0x2194	Masked port register port 5	ext ^[1]	word (32 bit)	Table 246
MPIN6	R/W	0x2198	Masked port register port 6	ext ^[1]	word (32 bit)	Table 246
MPIN7	R/W	0x219C	Masked port register port 7	ext ^[1]	word (32 bit)	Table 246
SET0	R/W	0x2200	Write: Set register for port 0 Read: output bits for port 0	0	word (32 bit)	Table 247
SET1	R/W	0x2204	Write: Set register for port 1 Read: output bits for port 1	0	word (32 bit)	Table 247
SET2	R/W	0x2208	Write: Set register for port 2 Read: output bits for port 2	0	word (32 bit)	Table 247
SET3	R/W	0x220C	Write: Set register for port 3 Read: output bits for port 3	0	word (32 bit)	Table 247
SET4	R/W	0x2210	Write: Set register for port 4 Read: output bits for port 4	0	word (32 bit)	Table 247
SET5	R/W	0x2214	Write: Set register for port 5 Read: output bits for port 5	0	word (32 bit)	Table 247
SET6	R/W	0x2218	Write: Set register for port 6 Read: output bits for port 6	0	word (32 bit)	Table 247
SET7	R/W	0x221C	Write: Set register for port 7 Read: output bits for port 7	0	word (32 bit)	Table 247
CLR0	WO	0x2280	Clear port 0	NA	word (32 bit)	Table 248
CLR1	WO	0x2284	Clear port 1	NA	word (32 bit)	Table 248
CLR2	WO	0x2288	Clear port 2	NA	word (32 bit)	Table 248
CLR3	WO	0x228C	Clear port 3	NA	word (32 bit)	Table 248

Table 227. Register overview: GPIO port (base address 0x400F 4000)
 The highest pin number on each port depends on package size (see [Table 222](#)).

Name	Access	Address offset	Description	Reset value	Width	Reference
CLR4	WO	0x2290	Clear port 4	NA	word (32 bit)	Table 248
CLR5	WO	0x2294	Clear port 5	NA	word (32 bit)	Table 248
CLR6	WO	0x2298	Clear port 6	NA	word (32 bit)	Table 248
CLR7	WO	0x229C	Clear port 7	NA	word (32 bit)	Table 248
NOT0	WO	0x2300	Toggle port 0	NA	word (32 bit)	Table 249
NOT1	WO	0x2304	Toggle port 1	NA	word (32 bit)	Table 249
NOT2	WO	0x2308	Toggle port 2	NA	word (32 bit)	Table 249
NOT3	WO	0x230C	Toggle port 3	NA	word (32 bit)	Table 249
NOT4	WO	0x2310	Toggle port 4	NA	word (32 bit)	Table 249
NOT5	WO	0x2314	Toggle port 5	NA	word (32 bit)	Table 249
NOT6	WO	0x2318	Toggle port 6	NA	word (32 bit)	Table 249
NOT7	WO	0x231C	Toggle port 7	NA	word (32 bit)	Table 249

[1] “ext” in this table and subsequent tables indicates that the data read after reset depends on the state of the pin, which in turn may depend on an external source.

18.5.1 GPIO pin interrupts register description

18.5.1.1 Pin interrupt mode register

For each of the 8 pin interrupts selected in the PINTSELn registers (see [Table 187](#) and [Table 188](#)), one bit in the ISEL register determines whether the interrupt is edge or level sensitive.

Table 228. Pin interrupt mode register (ISEL, address 0x4008 7000) bit description

Bit	Symbol	Description	Reset value	Access
7:0	PMODE	Selects the interrupt mode for each pin interrupt. Bit n configures the pin interrupt selected in PINTSELn. 0 = Edge sensitive 1 = Level sensitive	0	R/W
31:8	-	Reserved.	-	-

18.5.1.2 Pin interrupt level (rising edge) interrupt enable register

For each of the 8 pin interrupts selected in the PINTSELn registers (see [Table 187](#) and [Table 188](#)), one bit in the IENR register enables the interrupt depending on the pin interrupt mode configured in the ISEL register:

- If the pin interrupt mode is edge sensitive (PMODE = 0), the rising edge interrupt is enabled.
- If the pin interrupt mode is level sensitive (PMODE = 1), the level interrupt is enabled. The IENF register configures the active level (HIGH or LOW) for this interrupt.

Table 229. Pin interrupt level (rising edge) interrupt enable register (IENR, address 0x40087004) bit description

Bit	Symbol	Description	Reset value	Access
7:0	ENRL	Enables the rising edge or level interrupt for each pin interrupt. Bit n configures the pin interrupt selected in PINTSELn. 0 = Disable rising edge or level interrupt. 1 = Enable rising edge or level interrupt.	0	R/W
31:8	-	Reserved.	-	-

18.5.1.3 Pin interrupt level (rising edge) interrupt set register

For each of the 8 pin interrupts selected in the PINTSELn registers (see [Table 187](#) and [Table 188](#)), one bit in the SIENR register sets the corresponding bit in the IENR register depending on the pin interrupt mode configured in the ISEL register:

- If the pin interrupt mode is edge sensitive (PMODE = 0), the rising edge interrupt is set.
- If the pin interrupt mode is level sensitive (PMODE = 1), the level interrupt is set.

Table 230. Pin interrupt level (rising edge) interrupt set register (SIENR, address 0x40087008) bit description

Bit	Symbol	Description	Reset value	Access
7:0	SETENRL	Ones written to this address set bits in the IENR, thus enabling interrupts. Bit n sets bit n in the IENR register. 0 = No operation. 1 = Enable rising edge or level interrupt.	NA	WO
31:8	-	Reserved.	-	-

18.5.1.4 Pin interrupt level (rising edge interrupt) clear register

For each of the 8 pin interrupts selected in the PINTSELn registers (see [Table 187](#) and [Table 188](#)), one bit in the CIENR register clears the corresponding bit in the IENR register depending on the pin interrupt mode configured in the ISEL register:

- If the pin interrupt mode is edge sensitive (PMODE = 0), the rising edge interrupt is cleared.
- If the pin interrupt mode is level sensitive (PMODE = 1), the level interrupt is cleared.

Table 231. Pin interrupt level (rising edge interrupt) clear register (CIENR, address 0x4008700C) bit description

Bit	Symbol	Description	Reset value	Access
7:0	CENRL	Ones written to this address clear bits in the IENR, thus disabling the interrupts. Bit n clears bit n in the IENR register. 0 = No operation. 1 = Disable rising edge or level interrupt.	NA	WO
31:8	-	Reserved.	-	-

18.5.1.5 Pin interrupt active level (falling edge) interrupt enable register

For each of the 8 pin interrupts selected in the PINTSELn registers (see [Table 187](#) and [Table 188](#)), one bit in the IENF register enables the falling edge interrupt or the configures the level sensitivity depending on the pin interrupt mode configured in the ISEL register:

- If the pin interrupt mode is edge sensitive (PMODE = 0), the falling edge interrupt is enabled.
- If the pin interrupt mode is level sensitive (PMODE = 1), the active level of the level interrupt (HIGH or LOW) is configured.

Table 232. Pin interrupt active level (falling edge) interrupt enable register (IENF, address 0x4008 7010) bit description

Bit	Symbol	Description	Reset value	Access
7:0	ENAF	Enables the falling edge or configures the active level interrupt for each pin interrupt. Bit n configures the pin interrupt selected in PINTSELn. 0 = Disable falling edge interrupt or set active interrupt level LOW. 1 = Enable falling edge interrupt enabled or set active interrupt level HIGH.	0	R/W
31:8	-	Reserved.	-	-

18.5.1.6 Pin interrupt active level (falling edge) interrupt set register

For each of the 8 pin interrupts selected in the PINTSELn registers (see [Table 187](#) and [Table 188](#)), one bit in the SIENF register sets the corresponding bit in the IENF register depending on the pin interrupt mode configured in the ISEL register:

- If the pin interrupt mode is edge sensitive (PMODE = 0), the falling edge interrupt is set.
- If the pin interrupt mode is level sensitive (PMODE = 1), the HIGH-active interrupt is selected.

Table 233. Pin interrupt active level (falling edge interrupt) set register (SIENF, address 0x4008 7014) bit description

Bit	Symbol	Description	Reset value	Access
7:0	SETENAF	Ones written to this address set bits in the IENF, thus enabling interrupts. Bit n sets bit n in the IENF register. 0 = No operation. 1 = Select HIGH-active interrupt or enable falling edge interrupt.	NA	WO
31:8	-	Reserved.	-	-

18.5.1.7 Pin interrupt active level (falling edge interrupt) clear register

For each of the 8 pin interrupts selected in the PINTSELn registers (see [Table 187](#) and [Table 188](#)), one bit in the CIENF register sets the corresponding bit in the IENF register depending on the pin interrupt mode configured in the ISEL register:

- If the pin interrupt mode is edge sensitive (PMODE = 0), the falling edge interrupt is cleared.

- If the pin interrupt mode is level sensitive (PMODE = 1), the LOW-active interrupt is selected.

Table 234. Pin interrupt active level (falling edge) interrupt clear register (CIENF, address 0x4008 7018) bit description

Bit	Symbol	Description	Reset value	Access
7:0	CENAF	Ones written to this address clears bits in the IENF, thus disabling interrupts. Bit n clears bit n in the IENF register. 0 = No operation. 1 = LOW-active interrupt selected or falling edge interrupt disabled.	NA	WO
31:8	-	Reserved.	-	-

18.5.1.8 Pin interrupt rising edge register

This register contains ones for pin interrupts selected in the PINTSELn registers (see [Table 187](#) and [Table 188](#)) on which a rising edge has been detected. Writing ones to this register clears rising edge detection. Ones in this register assert an interrupt request for pins that are enabled for rising-edge interrupts. All edges are detected for all pins selected by the PINTSELn registers, regardless of whether they are interrupt-enabled.

Table 235. Pin interrupt rising edge register (RISE, address 0x4008 701C) bit description

Bit	Symbol	Description	Reset value	Access
7:0	RDET	Rising edge detect. Bit n detects the rising edge of the pin selected in PINTSELn. Read 0: No rising edge has been detected on this pin since Reset or the last time a one was written to this bit. Write 0: no operation. Read 1: a rising edge has been detected since Reset or the last time a one was written to this bit. Write 1: clear rising edge detection for this pin.	0	R/W
31:8	-	Reserved.	-	-

18.5.1.9 Pin interrupt falling edge register

This register contains ones for pin interrupts selected in the PINTSELn registers (see [Table 187](#) and [Table 188](#)) on which a falling edge has been detected. Writing ones to this register clears falling edge detection. Ones in this register assert an interrupt request for pins that are enabled for falling-edge interrupts. All edges are detected for all pins selected by the PINTSELn registers, regardless of whether they are interrupt-enabled.

Table 236. Pin interrupt falling edge register (FALL, address 0x4008 7020) bit description

Bit	Symbol	Description	Reset value	Access
7:0	FDET	Falling edge detect. Bit n detects the falling edge of the pin selected in PINTSELn. Read 0: No falling edge has been detected on this pin since Reset or the last time a one was written to this bit. Write 0: no operation. Read 1: a falling edge has been detected since Reset or the last time a one was written to this bit. Write 1: clear falling edge detection for this pin.	0	R/W
31:8	-	Reserved.	-	-

18.5.1.10 Pin interrupt status register

Reading this register returns ones for pin interrupts that are currently requesting an interrupt. For pins identified as edge-sensitive in the Interrupt Select register, writing ones to this register clears both rising- and falling-edge detection for the pin. For level-sensitive pins, writing ones inverts the corresponding bit in the Active level register, thus switching the active level on the pin.

Table 237. Pin interrupt status register (IST address 0x4008 7024) bit description

Bit	Symbol	Description	Reset value	Access
7:0	PSTAT	Pin interrupt status. Bit n returns the status, clears the edge interrupt, or inverts the active level of the pin selected in PINTSELn. Read 0: interrupt is not being requested for this interrupt pin. Write 0: no operation. Read 1: interrupt is being requested for this interrupt pin. Write 1 (edge-sensitive): clear rising- and falling-edge detection for this pin. Write 1 (level-sensitive): switch the active level for this pin (in the IENF register).	0	R/W
31:8	-	Reserved.	-	-

18.5.2 GPIO GROUP0/GROUP1 interrupt register description

18.5.2.1 Grouped interrupt control register

Table 238. GPIO grouped interrupt control register (CTRL, addresses 0x4008 8000 (GROUP0 INT) and 0x4008 9000 (GROUP1 INT)) bit description

Bit	Symbol	Value	Description	Reset value
0	INT		Group interrupt status. This bit is cleared by writing a one to it. Writing zero has no effect.	0
		0	No interrupt request is pending.	
		1	Interrupt request is active.	

Table 238. GPIO grouped interrupt control register (CTRL, addresses 0x4008 8000 (GROUP0 INT) and 0x4008 9000 (GROUP1 INT)) bit description

Bit	Symbol	Value	Description	Reset value
1	COMB		Combine enabled inputs for group interrupt	0
		0	OR functionality: A grouped interrupt is generated when any one of the enabled inputs is active (based on its programmed polarity).	
		1	AND functionality: An interrupt is generated when all enabled bits are active (based on their programmed polarity).	
2	TRIG		Group interrupt trigger	0
		0	Edge-triggered	
		1	Level-triggered	
31:3	-	-	Reserved	0

18.5.2.2 GPIO grouped interrupt port polarity registers

The grouped interrupt port polarity registers determine how the polarity of each enabled pin contributes to the grouped interrupt. Each port n (n = 0 to 7) is associated with its own port polarity register, and the values of all registers together determine the grouped interrupt.

Table 239. GPIO grouped interrupt port polarity registers (PORT_POL, addresses 0x4008 8020 (PORT_POL0) to 0x4008 803C (PORT_POL7) (GROUP0 INT) and 0x4008 9020 (PORT_POL0) to 0x4008 903C (PORT_POL7) (GROUP1 INT)) bit description

Bit	Symbol	Description	Reset value	Access value
31:0	POL	Configure pin polarity of port n pins for group interrupt. Bit m corresponds to pin GPIO[n][m] of port n. 0 = the pin is active LOW. If the level on this pin is LOW, the pin contributes to the group interrupt. 1 = the pin is active HIGH. If the level on this pin is HIGH, the pin contributes to the group interrupt.	1	-

18.5.2.3 GPIO grouped interrupt port enable registers

The grouped interrupt port enable registers enable the pins which contribute to the grouped interrupt. Each port n (n = 0 to 7) is associated with its own port enable register, and the values of all registers together determine which pins contribute to the grouped interrupt.

Table 240. GPIO grouped interrupt port n enable registers (PORT_ENA, addresses 0x4008 8040 (PORT_ENA0) to 0x4008 805C (PORT_ENA7) (GROUP0 INT) and 0x4008 9040 (PORT_ENA0) to 0x4008 905C (PORT_ENA7) (GROUP1 INT)) bit description

Bit	Symbol	Description	Reset value	Access value
31:0	ENA	Enable port n pin for group interrupt. Bit m corresponds to pin GPIO[n][m] of port n. 0 = the port n pin is disabled and does not contribute to the grouped interrupt. 1 = the port n pin is enabled and contributes to the grouped interrupt.	0	-

18.5.3 GPIO port register description

18.5.3.1 GPIO port byte pin registers

Each GPIO pin GPIO[n] has a byte register in this address range. The byte pin registers of GPIO port 0 correspond to registers B0 to B31, the byte pin registers of GPIO port 1 correspond to registers B32 to B63, etc. Byte addresses are reserved for unused GPIO port pins (see [Table 222](#)).

Software typically reads and writes bytes to access individual pins but also can read or write halfwords to sense or set the state of two pins, and read or write words to sense or set the state of four pins.

Remark: To read the signal on the GPIO input, enable the input buffer in the syscon block for the corresponding pin (see [Table 174](#) to [Table 176](#)).

Table 241. GPIO port byte pin registers (B, addresses 0x400F 4000 (B0) to 0x400F 40FF (B255)) bit description

Bit	Symbol	Description	Reset value	Access
0	PBYTE	Read: state of the pin GPIO[n], regardless of direction, masking, or alternate function. Pins configured as analog I/O always read as 0. Write: loads the pin's output bit.	ext	R/W
7:1		Reserved (0 on read, ignored on write)	0	-

18.5.3.2 GPIO port word pin registers

Each GPIO pin GPIO[n] has a word register in this address range. The word pin registers of GPIO port 0 correspond to registers W0 to W31, the word pin registers of GPIO port 1 correspond to registers W32 to W63, etc. Word addresses are reserved for unused GPIO port pins (see [Table 222](#)).

Any byte, halfword, or word read in this range will be all zeros if the pin is low or all ones if the pin is high, regardless of direction, masking, or alternate function, except that pins configured as analog I/O always read as zeros. Any write will clear the pin's output bit if the value written is all zeros, else it will set the pin's output bit.

Remark: To read the signal on the GPIO input, enable the input buffer in the syscon block for the corresponding pin (see [Table 174](#) to [Table 176](#)).

Table 242. GPIO port word pin registers (W, addresses 0x400F 5000 (W0) to 0x400F 13FC (W255)) bit description

Bit	Symbol	Description	Reset value	Access
31:0	PWORD	Read 0: pin GPIO[n] is LOW. Write 0: clear output bit. Read 0xFFFF FFFF: pin is HIGH. Write any value 0x0000 0001 to 0xFFFF FFFF: set output bit. Remark: Only 0 or 0xFFFF FFFF can be read. Writing any value other than 0 will set the output bit.	ext	R/W

18.5.3.3 GPIO port direction registers

Each GPIO port n ($n = 0$ to 7) has one direction register for configuring the port pins as inputs or outputs.

Table 243. GPIO port direction register (DIR, addresses 0x400F 6000 (DIR0) to 0x400F 601C (DIR7)) bit description

Bit	Symbol	Description	Reset value	Access
31:0	DIR	Selects pin direction for pin GPIO n [m] (bit 0 = GPIO n [0], bit 1 = GPIO n [1], ..., bit 31 = GPIO n [31]). 0 = input. 1 = output.	0	R/W

18.5.3.4 GPIO port mask registers

Each GPIO port has one mask register. The mask registers affect writing and reading the MPORT registers. Zeroes in these registers enable reading and writing; ones disable writing and result in zeros in corresponding positions when reading.

Table 244. GPIO port mask register (MASK, addresses 0x400F 6080 (MASK0) to 0x400F 609C (MASK7)) bit description

Bit	Symbol	Description	Reset value	Access
31:0	MASK	Controls which bits corresponding to GPIO n [m] are active in the MPORT register (bit 0 = GPIO n [0], bit 1 = GPIO n [1], ..., bit 31 = GPIO n [31]). 0 = Read MPORT: pin state; write MPORT: load output bit. 1 = Read MPORT: 0; write MPORT: output bit not affected.	0	R/W

18.5.3.5 GPIO port pin registers

Each GPIO port has one port pin register. Reading these registers returns the current state of the pins read, regardless of direction, masking, or alternate functions, except that pins configured as analog I/O always read as 0s. Writing these registers loads the output bits of the pins written to, regardless of the Mask register.

Remark: To read the signal on the GPIO input, enable the input buffer in the syscon block for the corresponding pin (see [Table 174](#) to [Table 176](#)).

Table 245. GPIO port pin register (PIN, addresses 0x400F 6100 (PIN0) to 0x400F 611C (PIN7)) bit description

Bit	Symbol	Description	Reset value	Access
31:0	PORT	Reads pin states or loads output bits (bit 0 = GPIO n [0], bit 1 = GPIO n [1], ..., bit 31 = GPIO n [31]). 0 = Read: pin is LOW; write: clear output bit. 1 = Read: pin is HIGH; write: set output bit.	ext	R/W

18.5.3.6 GPIO masked port pin registers

Each GPIO port has one masked port pin register. These registers are similar to the PORT registers, except that the value read is masked by ANDing with the inverted contents of the corresponding MASK register, and writing to one of these registers only affects output register bits that are enabled by zeros in the corresponding MASK register.

Table 246. GPIO masked port pin register (MPIN, addresses 0x400F 6180 (MPIN0) to 0x400F 619C (MPIN7)) bit description

Bit	Symbol	Description	Reset value	Access
31:0	MPORT	Masked port register (bit 0 = GPIO[0], bit 1 = GPIO[1], ..., bit 31 = GPIO[31]). 0 = Read: pin is LOW and/or the corresponding bit in the MASK register is 1; write: clear output bit if the corresponding bit in the MASK register is 0. 1 = Read: pin is HIGH and the corresponding bit in the MASK register is 0; write: set output bit if the corresponding bit in the MASK register is 0.	ext	R/W

18.5.3.7 GPIO port set registers

Each GPIO port has one port set register. Output bits can be set by writing ones to these registers, regardless of MASK registers. Reading from these register returns the port's output bits, regardless of pin directions.

Table 247. GPIO port set register (SET, addresses 0x400F 6200 (SET0) to 0x400F 621C (SET7)) bit description

Bit	Symbol	Description	Reset value	Access
31:0	SET	Read or set output bits (bit 0 = GPIO[0], bit 1 = GPIO[1], ..., bit 31 = GPIO[31]). 0 = Read: output bit; write: no operation. 1 = Read: output bit; write: set output bit.	0	R/W

18.5.3.8 GPIO port clear registers

Each GPIO port has one output clear register. Output bits can be cleared by writing ones to these write-only registers, regardless of MASK registers.

Table 248. GPIO port clear register (CLR, addresses 0x400F 6280 (CLR0) to 0x400F 629C (CLR7)) bit description

Bit	Symbol	Description	Reset value	Access
31:0	CLR	Clear output bits (bit 0 = GPIO[0], bit 1 = GPIO[1], ..., bit 31 = GPIO[31]): 0 = No operation. 1 = Clear output bit.	NA	WO

18.5.3.9 GPIO port toggle registers

Each GPIO port has one output toggle register. Output bits can be toggled/inverted/complemented by writing ones to these write-only registers, regardless of MASK registers.

Table 249. GPIO port toggle register (NOT, addresses 0x400F 6300 (NOT0) to 0x400F 632C (NOT7)) bit description

Bit	Symbol	Description	Reset value	Access
31:0	NOTP0	Toggle output bits (bit 0 = GPIO _n [0], bit 1 = GPIO _n [1], ..., bit 31 = GPIO _n [31]): 0 = no operation. 1 = Toggle output bit.	NA	WO

18.6 Functional description

18.6.1 Reading pin state

Software can read the state of all GPIO pins except those selected for analog input or output in the “I/O Configuration” logic. A pin does not have to be selected for GPIO in “I/O Configuration” in order to read its state. There are four ways to read pin state:

- The state of a single pin can be read with 7 high-order zeros from a Byte Pin register.
- The state of a single pin can be read in all bits of a byte, halfword, or word from a Word Pin register.
- The state of multiple pins in a port can be read as a byte, halfword, or word from a PORT register.
- The state of a selected subset of the pins in a port can be read from a Masked Port (MPORT) register. Pins having a 1 in the port’s Mask register will read as 0 from its MPORT register.

18.6.2 GPIO output

Each GPIO pin has an output bit in the GPIO block. These output bits are the targets of write operations “to the pins”. Two conditions must be met in order for a pin’s output bit to be driven onto the pin:

1. The pin must be selected for GPIO operation in the “I/O Configuration” block, and
2. the pin must be selected for output by a 1 in its port’s DIR register.

If either or both of these conditions is (are) not met, “writing to the pin” has no effect.

There are seven ways to change GPIO output bits:

- Writing to a Byte Pin register loads the output bit from the least significant bit.
- Writing to a Word Pin register loads the output bit with the OR of all of the bits written. (This feature follows the definition of “truth” of a multi-bit value in programming languages.)
- Writing to a port’s PORT register loads the output bits of all the pins written to.
- Writing to a port’s MPORT register loads the output bits of pins identified by zeros in corresponding positions of the port’s MASK register.
- Writing ones to a port’s SET register sets output bits.
- Writing ones to a port’s CLR register clears output bits.
- Writing ones to a port’s NOT register toggles/complements/inverts output bits.

The state of a port's output bits can be read from its SET register. Reading any of the registers described in [18.6.1](#) returns the state of pins, regardless of their direction or alternate functions.

18.6.3 Masked I/O

A port's MASK register defines which of its pins should be accessible in its MPORT register. Zeroes in MASK enable the corresponding pins to be read from and written to MPORT. Ones in MASK force a pin to read as 0 and its output bit to be unaffected by writes to MPORT. When a port's MASK register contains all zeros, its PORT and MPORT registers operate identically for reading and writing.

Users of previous NXP devices with similar GPIO blocks should be aware of an incompatibility: on the LPC18xx, writing to the SET, CLR, and NOT registers is not affected by the MASK register. On previous devices these registers were masked.

Applications in which interrupts can result in Masked GPIO operation, or in task switching among tasks that do Masked GPIO operation, must treat code that uses the Mask register as a protected/restricted region. This can be done by interrupt disabling or by using a semaphore.

The simpler way to protect a block of code that uses a MASK register is to disable interrupts before setting the MASK register, and re-enable them after the last operation that uses the MPORT or MASK register.

More efficiently, software can dedicate a semaphore to the MASK registers, and set/capture the semaphore controlling exclusive use of the MASK registers before setting the MASK registers, and release the semaphore after the last operation that uses the MPORT or MASK registers.

18.6.4 GPIO Interrupts

Two separate GPIO interrupt facilities are provided. With pin interrupts, up to eight GPIO pins can each have separately-vectored, edge- or level-sensitive interrupts.

With group interrupts, any subset of the pins in each port can be selected to contribute to a common interrupt. Any of the pin and port interrupts can be enabled in the NVIC to wake the part from Sleep mode.

18.6.4.1 Pin interrupts

In this interrupt facility, up to 8 pins are identified as interrupt sources by the Pin Interrupt Select registers (PINTSEL0-7). All registers in the pin interrupt block contain 8 bits, corresponding to the pins called out by the PINTSEL0-7 registers. The ISEL register defines whether each interrupt pin is edge- or level-sensitive. The RISE and FALL registers detect edges on each interrupt pin, and can be written to clear (and set) edge detection. The IST register indicates whether each interrupt pin is currently requesting an interrupt, and this register can also be written to clear interrupts.

The other pin interrupt registers play different roles for edge-sensitive and level-sensitive pins, as described in [Table 250](#).

Table 250. Pin interrupt registers for edge- and level-sensitive pins

Name	Edge-sensitive function	Level-sensitive function
IENR	Enables rising-edge interrupts.	Enables level interrupts.
SIENR	Write to enable rising-edge interrupts.	Write to enable level interrupts.
CIENR	Write to disable rising-edge interrupts.	Write to disable level interrupts.
IENF	Enables falling-edge interrupts.	Selects active level.
SIENF	Write to enable falling-edge interrupts.	Write to select high-active.
CIENF	Write to disable falling-edge interrupts.	Write to select low-active.

18.6.4.2 Group interrupts

In this interrupt facility, an interrupt can be requested for each port, based on any selected subset of pins within each port. The pins that contribute to each port interrupt are selected by 1s in the port's Enable register, and an interrupt polarity can be selected for each pin in the port's Polarity register. The level on each pin is exclusive-ORed with its polarity bit and the result is ANDed with its enable bit, and these results are then inclusive-ORed among all the pins in the port, to create the port's raw interrupt request.

The raw interrupt request from each of the two group interrupts is sent to the NVIC, which can be programmed to treat it as level- or edge-sensitive (see [Table 71](#)).

18.6.5 Recommended practices

The following lists some recommended uses for using the GPIO port registers:

- For initial setup after Reset or re-initialization, write the PORT registers.
- To change the state of one pin, write a Byte Pin or Word Pin register.
- To change the state of multiple pins at a time, write the SET and/or CLR registers.
- To change the state of multiple pins in a tightly controlled environment like a software state machine, consider using the NOT register. This can require less write operations than SET and CLR.
- To read the state of one pin, read a Byte Pin or Word Pin register.
- To make a decision based on multiple pins, read and mask a PORT register.

19.1 How to read this chapter

The GPDMA is available on all LPC18xx parts. The AES DMA request lines are only available on secure parts.

19.2 Basic configuration

The GPDMA is configured as follows:

- See [Table 251](#) for clocking and power control.
- The GPDMA is reset by the DMA_RST (reset # 19).
- The DMAMUX register in the CREG block (see [Table 92](#)) selects between up to three peripherals for each GPDMA-to-peripheral line.
- The GPIO block, the WWDT, and the timers can be accessed by the GPDMA as memory-to-memory transfers.

Table 251. GPDMA clocking and power control

	Base clock	Branch clock	Operating frequency
GPDMA	BASE_M3_CLK	CLK_M3_DMA	up to 180 MHz

19.3 Features

- Eight DMA channels. Each channel can support an unidirectional transfer.
- 16 DMA request lines.
- Single DMA and burst DMA request signals. Each peripheral connected to the DMA Controller can assert either a burst DMA request or a single DMA request. The DMA burst size is set by programming the DMA Controller.
- Memory-to-memory, memory-to-peripheral, peripheral-to-memory, and peripheral-to-peripheral transfers are supported.
- The GPIO block, the WWDT, and the timers can be accessed by the GPDMA as memory-to-memory transfers.
- Scatter or gather DMA is supported through the use of linked lists. This means that the source and destination areas do not have to occupy contiguous areas of memory.
- Hardware DMA channel priority.
- AHB slave DMA programming interface. The DMA Controller is programmed by writing to the DMA control registers over the AHB slave interface.
- Two AHB bus masters for transferring data. These interfaces transfer data when a DMA request goes active. Master 1 can access memories and peripherals, master 0 can access memories only.
- 32-bit AHB master bus width.
- Incrementing or non-incrementing addressing for source and destination.

- Programmable DMA burst size. The DMA burst size can be programmed to more efficiently transfer data.
- Internal four-word FIFO per channel.
- Supports 8, 16, and 32-bit wide transactions.
- Big-endian and little-endian support. The DMA Controller defaults to little-endian mode on reset.
- An interrupt to the processor can be generated on a DMA completion or when a DMA error has occurred.
- Raw interrupt status. The DMA error and DMA count raw interrupt status can be read prior to masking.

19.4 General description

The DMA controller allows peripheral-to-memory, memory-to-peripheral, peripheral-to-peripheral, and memory-to-memory transactions. Each DMA stream provides unidirectional serial DMA transfers for a single source and destination. For example, a bi-directional port requires one stream for transmit and one for receives. The source and destination areas can each be either a memory region or a peripheral for master 1. Master 0 can only access memory (see [Section 2.6](#)).

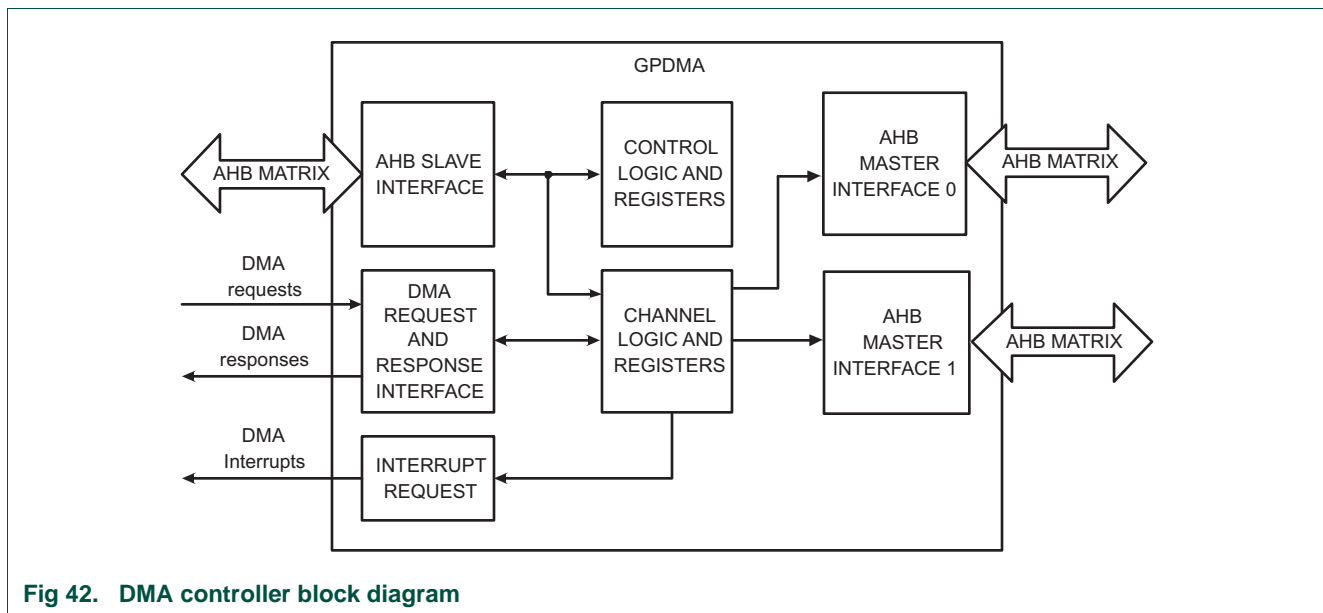

Fig 42. DMA controller block diagram

19.5 DMA system connections

The connection of the DMA Controller to supported peripheral devices is shown in [Table 252](#). The LPC18xx supports multiple muxing options for each channel to connect peripherals to the DMA. The DMAMUX register in the CREG block controls which option is used (see [Table 92](#)).

Table 252. Peripheral connections to the DMA controller and matching flow control signals

Peripheral Number	DMA muxing option (see Table 92)	SREQ	BREQ
0	0x0	SPIFI	SPIFI
	0x1	-	SCT CTOUT_2
	0x2	Reserved	Reserved
	0x3	-	Timer3 match 1
1	0x0	-	Timer0 match 0
	0x1	-	USART0 transmit
	0x2	Reserved	Reserved
	0x3	Reserved	AES in
2	0x0	-	Timer0 match 1
	0x1	-	USART0 receive
	0x2	Reserved	Reserved
	0x3	Reserved	AES out
3	0x0	-	Timer1 match 0
	0x1	-	UART1 transmit
	0x2	-	I2S1 DMA request 1
	0x3	SSP1 transmit	SSP1 transmit
4	0x0	-	Timer1 match 1
	0x1	-	UART1 receive
	0x2	-	I2S1 DMA request 2
	0x3	SSP1 receive	SSP1 receive
5	0x0	-	Timer2 match 0
	0x1	-	USART2 transmit
	0x2	SSP1 transmit	SSP1 transmit
	0x3	Reserved	Reserved
6	0x0	-	Timer2 match 1
	0x1	-	USART2 receive
	0x2	SSP1 receive	SSP1 receive
	0x3	Reserved	Reserved
7	0x0	-	Timer3 match 0
	0x1	-	USART3 transmit
	0x2	-	SCT DMA request 0
	0x3	Reserved	Reserved
8	0x0	-	Timer3 match 1
	0x1	-	USART3 receive
	0x2	-	SCT DMA request 1
	0x3	Reserved	Reserved

Table 252. Peripheral connections to the DMA controller and matching flow control signals

Peripheral Number	DMA muxing option (see Table 92)	SREQ	BREQ
9	0x0	SSP0 receive	SSP0 receive
	0x1	-	I2S0 DMA request 1
	0x2	-	SCT DMA request 1
	0x3	-	n.c.
10	0x0	SSP0 transmit	SSP0 transmit
	0x1	-	I2S0 DMA request 2
	0x2	-	SCT DMA request 0
	0x3	-	n.c.
11	0x0	SSP1 receive	SSP1 receive
	0x1	Reserved	Reserved
	0x2	-	USART0 transmit
	0x3	-	n.c.
12	0x0	SSP1 transmit	SSP1 transmit
	0x1	Reserved	Reserved
	0x2	-	USART0 receive
	0x3	-	n.c.
13	0x0	-	ADC0
	0x1	Reserved	AES in
	0x2	SSP1 receive	SSP1 receive
	0x3	-	USART3 receive
14	0x0	-	ADC1
	0x1	Reserved	AES out
	0x2	SSP1 transmit	SSP1 transmit
	0x3	-	USART3 transmit
15	0x0	-	DAC
	0x1	-	SCT CTOUT_3
	0x2	Reserved	Reserved
	0x3	-	Timer3 match 0

In addition to the peripherals listed in [Table 252](#), the GPIOs, the WWDT, and the timers can be accessed by the GPDMA as a memory-to-memory transaction with no flow control.

19.5.1 DMA request signals

The DMA request signals are used by peripherals to request a data transfer. The DMA request signals indicate whether a single or burst transfer of data is required and whether the transfer is the last in the data packet. The DMA available request signals are:

BREQ[15:0] — Burst request signals. These cause a programmed burst number of data to be transferred.

SREQ[15:0] — Single transfer request signals. These cause a single data to be transferred. The DMA controller transfers a single transfer to or from the peripheral.

LBREQ[15:0] — Last burst request signals.

LSREQ[15:0] — Last single transfer request signals.

Note that most peripherals do not support all request types.

19.5.2 DMA response signals

The DMA response signals indicate whether the transfer initiated by the DMA request signal has completed. The response signals can also be used to indicate whether a complete packet has been transferred. The DMA response signals from the DMA controller are:

CLR[15:0] — DMA clear or acknowledge signals. The CLR signal is used by the DMA controller to acknowledge a DMA request from the peripheral.

TC[15:0] — DMA terminal count signals. The TC signal can be used by the DMA controller to indicate to the peripheral that the DMA transfer is complete.

19.6 Register description

The DMA Controller supports 8 channels. Each channel has registers specific to the operation of that channel. Other registers controls aspects of how source peripherals relate to the DMA Controller. There are also global DMA control and status registers.

Table 253. Register overview: GPDMA (base address 0x4000 2000)

Name	Access	Address offset	Description	Reset value	Reference
General registers					
INTSTAT	RO	0x000	DMA Interrupt Status Register	0x0000 0000	Table 254
INTTCSTAT	RO	0x004	DMA Interrupt Terminal Count Request Status Register	0x0000 0000	Table 255
INTTCCLEAR	WO	0x008	DMA Interrupt Terminal Count Request Clear Register	-	Table 256
INTERRSTAT	RO	0x00C	DMA Interrupt Error Status Register	0x0000 0000	Table 257
INTERRCLR	WO	0x010	DMA Interrupt Error Clear Register	-	Table 258
RAWINTTCSTAT	RO	0x014	DMA Raw Interrupt Terminal Count Status Register	0x0000 0000	Table 259
RAWINTERRSTAT	RO	0x018	DMA Raw Error Interrupt Status Register	0x0000 0000	Table 260
ENBLDCHNS	RO	0x01C	DMA Enabled Channel Register	0x0000 0000	Table 261
SOFTBREQ	R/W	0x020	DMA Software Burst Request Register	0x0000 0000	Table 262
SOFTSREQ	R/W	0x024	DMA Software Single Request Register	0x0000 0000	Table 263
SOFTLBREQ	R/W	0x028	DMA Software Last Burst Request Register	0x0000 0000	Table 264
SOFTLSREQ	R/W	0x02C	DMA Software Last Single Request Register	0x0000 0000	Table 265
CONFIG	R/W	0x030	DMA Configuration Register	0x0000 0000	Table 266
SYNC	R/W	0x034	DMA Synchronization Register	0x0000 0000	Table 267

Channel 0 registers

Table 253. Register overview: GPDMA (base address 0x4000 2000) ...continued

Name	Access	Address offset	Description	Reset value	Reference
SRCADDR0	R/W	0x100	DMA Channel 0 Source Address Register	0x0000 0000	Table 268
DESTADDR0	R/W	0x104	DMA Channel 0 Destination Address Register	0x0000 0000	Table 269
LLI0	R/W	0x108	DMA Channel 0 Linked List Item Register	0x0000 0000	Table 270
CONTROL0	R/W	0x10C	DMA Channel 0 Control Register	0x0000 0000	Table 271
CONFIG0	R/W	0x110	DMA Channel 0 Configuration Register ^[1]	0x0000 0000	Table 272
Channel 1 registers					
SRCADDR1	R/W	0x120	DMA Channel 1 Source Address Register	0x0000 0000	Table 268
DESTADDR1	R/W	0x124	DMA Channel 1 Destination Address Register	0x0000 0000	Table 269
LLI1	R/W	0x128	DMA Channel 1 Linked List Item Register	0x0000 0000	Table 270
CONTROL1	R/W	0x12C	DMA Channel 1 Control Register	0x0000 0000	Table 271
CONFIG1	R/W	0x130	DMA Channel 1 Configuration Register ^[1]	0x0000 0000	Table 272
Channel 2 registers					
SRCADDR2	R/W	0x140	DMA Channel 2 Source Address Register	0x0000 0000	Table 268
DESTADDR2	R/W	0x144	DMA Channel 2 Destination Address Register	0x0000 0000	Table 269
LLI2	R/W	0x148	DMA Channel 2 Linked List Item Register	0x0000 0000	Table 270
CONTROL2	R/W	0x14C	DMA Channel 2 Control Register	0x0000 0000	Table 271
CONFIG2	R/W	0x150	DMA Channel 2 Configuration Register ^[1]	0x0000 0000	Table 272
Channel 3 registers					
SRCADDR3	R/W	0x160	DMA Channel 3 Source Address Register	0x0000 0000	Table 268
DESTADDR3	R/W	0x164	DMA Channel 3 Destination Address Register	0x0000 0000	Table 269
LLI3	R/W	0x168	DMA Channel 3 Linked List Item Register	0x0000 0000	Table 270
CONTROL3	R/W	0x16C	DMA Channel 3 Control Register	0x0000 0000	Table 271
CONFIG3	R/W	0x170	DMA Channel 3 Configuration Register ^[1]	0x0000 0000	Table 272
Channel 4 registers					
SRCADDR4	R/W	0x180	DMA Channel 4 Source Address Register	0x0000 0000	Table 268
DESTADDR4	R/W	0x184	DMA Channel 4 Destination Address Register	0x0000 0000	Table 269
LLI4	R/W	0x188	DMA Channel 4 Linked List Item Register	0x0000 0000	Table 270
CONTROL4	R/W	0x18C	DMA Channel 4 Control Register	0x0000 0000	Table 271
CONFIG4	R/W	0x190	DMA Channel 4 Configuration Register ^[1]	0x0000 0000	Table 272
Channel 5 registers					
SRCADDR5	R/W	0x1A0	DMA Channel 5 Source Address Register	0x0000 0000	Table 268
DESTADDR5	R/W	0x1A4	DMA Channel 5 Destination Address Register	0x0000 0000	Table 269
LLI5	R/W	0x1A8	DMA Channel 5 Linked List Item Register	0x0000 0000	Table 270
CONTROL5	R/W	0x1AC	DMA Channel 5 Control Register	0x0000 0000	Table 271
CONFIG5	R/W	0x1B0	DMA Channel 5 Configuration Register ^[1]	0x0000 0000	Table 272
Channel 6 registers					
SRCADDR6	R/W	0x1C0	DMA Channel 6 Source Address Register	0x0000 0000	Table 268
DESTADDR6	R/W	0x1C4	DMA Channel 6 Destination Address Register	0x0000 0000	Table 269
LLI6	R/W	0x1C8	DMA Channel 6 Linked List Item Register	0x0000 0000	Table 270
CONTROL6	R/W	01CC	DMA Channel 6 Control Register	0x0000 0000	Table 271

Table 253. Register overview: GPDMA (base address 0x4000 2000) ...continued

Name	Access	Address offset	Description	Reset value	Reference
CONFIG6	R/W	0x1D0	DMA Channel 6 Configuration Register ^[1]	0x0000 0000	Table 272
Channel 7 registers					
SRCADDR7	R/W	0x1E0	DMA Channel 7 Source Address Register	0x0000 0000	Table 268
DESTADDR7	R/W	0x1E4	DMA Channel 7 Destination Address Register	0x0000 0000	Table 269
LLI7	R/W	0x1E8	DMA Channel 7 Linked List Item Register	0x0000 0000	Table 270
CONTROL7	R/W	0x1EC	DMA Channel 7 Control Register	0x0000 0000	Table 271
CONFIG7	R/W	0x1F0	DMA Channel 7 Configuration Register ^[1]	0x0000 0000	Table 272

[1] Bit 17 of this register is a read-only status flag.

19.6.1 DMA Interrupt Status Register

The IntStat Register is read-only and shows the status of the interrupts after masking. A HIGH bit indicates that a specific DMA channel interrupt request is active. The request can be generated from either the error or terminal count interrupt requests.

Table 254. DMA Interrupt Status register (INTSTAT, address 0x4000 2000) bit description

Bit	Symbol	Description	Reset value	Access
7:0	INTSTAT	Status of DMA channel interrupts after masking. Each bit represents one channel: 0 - the corresponding channel has no active interrupt request. 1 - the corresponding channel does have an active interrupt request.	0x00	RO
31:8	-	Reserved. Read undefined.	-	-

19.6.2 DMA Interrupt Terminal Count Request Status Register

The INTTCSTAT Register is read-only and indicates the status of the terminal count after masking.

Table 255. DMA Interrupt Terminal Count Request Status Register (INTTCSTAT, address 0x4000 2004) bit description

Bit	Symbol	Description	Reset value	Access
7:0	INTTCSTAT	Terminal count interrupt request status for DMA channels. Each bit represents one channel: 0 - the corresponding channel has no active terminal count interrupt request. 1 - the corresponding channel does have an active terminal count interrupt request.	0x00	RO
31:8	-	Reserved. Read undefined.	-	-

19.6.3 DMA Interrupt Terminal Count Request Clear Register

The INTTCLEAR Register is write-only and clears one or more terminal count interrupt requests. When writing to this register, each data bit that is set HIGH causes the corresponding bit in the status register (IntTCStat) to be cleared. Data bits that are LOW have no effect.

Table 256. DMA Interrupt Terminal Count Request Clear Register (INTTCLEAR, address 0x4000 2008) bit description

Bit	Symbol	Description	Reset value	Access
7:0	INTTCLEAR	Allows clearing the Terminal count interrupt request (IntTCStat) for DMA channels. Each bit represents one channel: 0 - writing 0 has no effect. 1 - clears the corresponding channel terminal count interrupt.	0x00	WO
31:8	-	Reserved. Read undefined. Write reserved bits as zero.	-	-

19.6.4 DMA Interrupt Error Status Register

The INTERRSTAT Register is read-only and indicates the status of the error request after masking.

Table 257. DMA Interrupt Error Status Register (INTERRSTAT, address 0x4000 200C) bit description

Bit	Symbol	Description	Reset value	Access
7:0	INTERRSTAT	Interrupt error status for DMA channels. Each bit represents one channel: 0 - the corresponding channel has no active error interrupt request. 1 - the corresponding channel does have an active error interrupt request.	0x00	RO
31:8	-	Reserved. Read undefined.	-	-

19.6.5 DMA Interrupt Error Clear Register

The INTERRCLR Register is write-only and clears the error interrupt requests. When writing to this register, each data bit that is HIGH causes the corresponding bit in the status register to be cleared. Data bits that are LOW have no effect on the corresponding bit in the register.

Table 258. DMA Interrupt Error Clear Register (INTERRCLR, address 0x4000 2010) bit description

Bit	Symbol	Description	Reset value	Access
7:0	INTERRCLR	Writing a 1 clears the error interrupt request (IntErrStat) for DMA channels. Each bit represents one channel: 0 - writing 0 has no effect. 1 - clears the corresponding channel error interrupt.	0x00	WO
31:8	-	Reserved. Read undefined. Write reserved bits as zero.	-	-

19.6.6 DMA Raw Interrupt Terminal Count Status Register

The RAWINTTCSTAT Register is read-only and indicates which DMA channel is requesting a transfer complete (terminal count interrupt) prior to masking. (Note: the IntTCStat Register contains the same information after masking.) A HIGH bit indicates that the terminal count interrupt request is active prior to masking.

Table 259. DMA Raw Interrupt Terminal Count Status Register (RAWINTTCSTAT, address 0x4000 2014) bit description

Bit	Symbol	Description	Reset value	Access
7:0	RAWINTTCSTAT	Status of the terminal count interrupt for DMA channels prior to masking. Each bit represents one channel: 0 - the corresponding channel has no active terminal count interrupt request. 1 - the corresponding channel does have an active terminal count interrupt request.	0x00	RO
31:8	-	Reserved. Read undefined.	-	-

19.6.7 DMA Raw Error Interrupt Status Register

The RAWINTERRSTAT Register is read-only and indicates which DMA channel is requesting an error interrupt prior to masking. (Note: the IntErrStat Register contains the same information after masking.) A HIGH bit indicates that the error interrupt request is active prior to masking.

Table 260. DMA Raw Error Interrupt Status Register (RAWINTERRSTAT, address 0x4000 2018) bit description

Bit	Symbol	Description	Reset value	Access
7:0	RAWINTERRSTAT	Status of the error interrupt for DMA channels prior to masking. Each bit represents one channel: 0 - the corresponding channel has no active error interrupt request. 1 - the corresponding channel does have an active error interrupt request.	0x00	RO
31:8	-	Reserved. Read undefined.	-	-

19.6.8 DMA Enabled Channel Register

The ENBLDCHNS Register is read-only and indicates which DMA channels are enabled, as indicated by the Enable bit in the CCONFIG Register. A HIGH bit indicates that a DMA channel is enabled. A bit is cleared on completion of the DMA transfer.

Table 261. DMA Enabled Channel Register (ENBLDCHNS, address 0x4000 201C) bit description

Bit	Symbol	Description	Reset value	Access
7:0	ENABLEDCHANNELS	Enable status for DMA channels. Each bit represents one channel: 0 - DMA channel is disabled. 1 - DMA channel is enabled.	0x00	RO
31:8	-	Reserved. Read undefined.	-	-

19.6.9 DMA Software Burst Request Register

The SOFTBREQ Register is read/write and enables DMA burst requests to be generated by software. A DMA request can be generated for each source by writing a 1 to the corresponding register bit. A register bit is cleared when the transaction has completed. Reading the register indicates which sources are requesting DMA burst transfers. A request can be generated from either a peripheral or the software request register. Each bit is cleared when the related transaction has completed.

Table 262. DMA Software Burst Request Register (SOFTBREQ, address 0x4000 2020) bit description

Bit	Symbol	Description	Reset value	Access
15:0	SOFTBREQ	Software burst request flags for each of 16 possible sources. Each bit represents one DMA request line or peripheral function (refer to Table 252 for peripheral hardware connections to the DMA controller): 0 - writing 0 has no effect. 1 - writing 1 generates a DMA burst request for the corresponding request line.	0x00	R/W
31:16	-	Reserved. Read undefined. Write reserved bits as zero.	-	-

Note: It is recommended that software and hardware peripheral requests are not used at the same time.

19.6.10 DMA Software Single Request Register

The SOFTSREQ Register is read/write and enables DMA single transfer requests to be generated by software. A DMA request can be generated for each source by writing a 1 to the corresponding register bit. A register bit is cleared when the transaction has completed. Reading the register indicates which sources are requesting single DMA transfers. A request can be generated from either a peripheral or the software request register.

Table 263. DMA Software Single Request Register (SOFTSREQ, address 0x4000 2024) bit description

Bit	Symbol	Description	Reset value	Access
15:0	SOFTSREQ	Software single transfer request flags for each of 16 possible sources. Each bit represents one DMA request line or peripheral function: 0 - writing 0 has no effect. 1 - writing 1 generates a DMA single transfer request for the corresponding request line.	0x00	R/W
31:16	-	Reserved. Read undefined. Write reserved bits as zero.	-	-

19.6.11 DMA Software Last Burst Request Register

The SOFTLBREQ Register is read/write and enables DMA last burst requests to be generated by software. A DMA request can be generated for each source by writing a 1 to the corresponding register bit. A register bit is cleared when the transaction has completed. Reading the register indicates which sources are requesting last burst DMA transfers. A request can be generated from either a peripheral or the software request register.

Table 264. DMA Software Last Burst Request Register (SOFTLBREQ, address 0x4000 2028) bit description

Bit	Symbol	Description	Reset value	Access
15:0	SOFTLBREQ	Software last burst request flags for each of 16 possible sources. Each bit represents one DMA request line or peripheral function: 0 - writing 0 has no effect. 1 - writing 1 generates a DMA last burst request for the corresponding request line.	0x00	R/W
31:16	-	Reserved. Read undefined. Write reserved bits as zero.	-	-

19.6.12 DMA Software Last Single Request Register

The SOFTLSREQ Register is read/write and enables DMA last single requests to be generated by software. A DMA request can be generated for each source by writing a 1 to the corresponding register bit. A register bit is cleared when the transaction has completed. Reading the register indicates which sources are requesting last single DMA transfers. A request can be generated from either a peripheral or the software request register.

Table 265. DMA Software Last Single Request Register (SOFTLSREQ, address 0x4000 202C) bit description

Bit	Symbol	Description	Reset value	Access
15:0	SOFTLSREQ	Software last single transfer request flags for each of 16 possible sources. Each bit represents one DMA request line or peripheral function: 0 - writing 0 has no effect. 1 - writing 1 generates a DMA last single transfer request for the corresponding request line.	0x00	R/W
31:16	-	Reserved. Read undefined. Write reserved bits as zero.	-	-

19.6.13 DMA Configuration Register

The CONFIG Register is read/write and configures the operation of the DMA Controller. The endianness of the AHB master interface can be altered by writing to the M bit of this register. The AHB master interface is set to little-endian mode on reset.

Table 266. DMA Configuration Register (CONFIG, address 0x4000 2030) bit description

Bit	Symbol	Value	Description	Reset value	Access
0	E		DMA Controller enable:	0x00	R/W
		0	Disabled (default). Disabling the DMA Controller reduces power consumption.		
		1	Enabled		
1	M0		AHB Master 0 endianness configuration:	0x00	R/W
		0	Little-endian mode (default).		
		1	Big-endian mode.		
2	M1		AHB Master 1 endianness configuration:	0x00	R/W
		0	Little-endian mode (default).		
		1	Big-endian mode.		
31:3	-		Reserved. Read undefined. Write reserved bits as zero.		

19.6.14 DMA Synchronization Register

The Sync Register is read/write and enables or disables synchronization logic for the DMA request signals. The DMA request signals consist of the BREQ[15:0], SREQ[15:0], LBREQ[15:0], and LSREQ[15:0]. A bit set to 0 enables the synchronization logic for a particular group of DMA requests. A bit set to 1 disables the synchronization logic for a particular group of DMA requests. This register is reset to 0 enabling the synchronization logic by default.

Table 267. DMA Synchronization Register (SYNC, address 0x4000 2034) bit description

Bit	Symbol	Description	Reset value	Access
15:0	DMACSYNC	Controls the synchronization logic for DMA request signals. Each bit represents one set of DMA request lines as described in the preceding text: 0 - synchronization logic for the corresponding DMA request signals are enabled. 1 - synchronization logic for the corresponding request line signals are disabled.	0x00	R/W
31:16	-	Reserved. Read undefined. Write reserved bits as zero.	-	-

19.6.15 DMA Channel registers

The channel registers are used to program the eight DMA channels. These registers consist of:

- Eight SRCADDR Registers.
- Eight DESTADDR Registers.
- Eight LLI Registers.
- Eight CONTROL Registers.
- Eight CONFIG Registers.

When performing scatter/gather DMA, the first four of these are automatically updated.

19.6.16 DMA Channel Source Address Registers

The eight read/write SRCADDR Registers contain the current source address (byte-aligned) of the data to be transferred. Each register is programmed directly by software before the appropriate channel is enabled. When the DMA channel is enabled this register is updated:

- As the source address is incremented.
- By following the linked list when a complete packet of data has been transferred.

Reading the register when the channel is active does not provide useful information. This is because by the time software has processed the value read, the address may have progressed. It is intended to be read only when the channel has stopped, in which case it shows the source address of the last item read.

Note: The source and destination addresses must be aligned to the source and destination widths.

Table 268. DMA Channel Source Address Registers (SRCADDR[0:7], 0x4000 2100 (SRCADDR0) to 0x4000 21E0 (SRCADDR7)) bit description

Bit	Symbol	Description	Reset value	Access
31:0	SRCADDR	DMA source address. Reading this register will return the current source address.	0x0000 0000	R/W

19.6.17 DMA Channel Destination Address registers

The eight read/write DESTADDR Registers contain the current destination address (byte-aligned) of the data to be transferred. Each register is programmed directly by software before the channel is enabled. When the DMA channel is enabled the register is updated as the destination address is incremented and by following the linked list when a complete packet of data has been transferred. Reading the register when the channel is active does not provide useful information. This is because by the time that software has processed the value read, the address may have progressed. It is intended to be read only when a channel has stopped, in which case it shows the destination address of the last item read.

Table 269. DMA Channel Destination Address registers (DESTADDR[0:7], 0x4000 2104 (DESTADDR0) to 0x4000 21E4 (DESTADDR7)) bit description

Bit	Symbol	Description	Reset value	Access
31:0	DESTADDR	DMA Destination address. Reading this register will return the current destination address.	0x0000 0000	R/W

19.6.18 DMA Channel Linked List Item registers

The eight read/write LLI Registers contain a word-aligned address of the next Linked List Item (LLI). If the LLI is 0, then the current LLI is the last in the chain, and the DMA channel is disabled when all DMA transfers associated with it are completed. Programming this register when the DMA channel is enabled may have unpredictable side effects.

Table 270. DMA Channel Linked List Item registers (LLI[0:7], 0x4000 2108 (LLI0) to 0x4000 21E8 (LLI7)) bit description

Bit	Symbol	Value	Description	Reset value	Access
0	LM		AHB master select for loading the next LLI:	0	R/W
		0	AHB Master 0.		
		1	AHB Master 1.		
1	R		Reserved, and must be written as 0, masked on read.	0	R/W
31:2	LLI		Linked list item. Bits [31:2] of the address for the next LLI. Address bits [1:0] are 0.	0x0000 0000	R/W

19.6.19 DMA channel control registers

The eight read/write CONTROL Registers contain DMA channel control information such as the transfer size, burst size, and transfer width. Each register is programmed directly by software before the DMA channel is enabled. When the channel is enabled the register is updated by following the linked list when a complete packet of data has been transferred. Reading the register while the channel is active does not give useful information. This is because by the time software has processed the value read, the channel may have advanced. It is intended to be read only when a channel has stopped.

Table 271. DMA Channel Control registers (CONTROL[0:7], 0x4000 210C (CONTROL0) to 0x4000 21EC (CONTROL7)) bit description

Bit	Symbol	Value	Description	Reset value	Access
11:0	TRANSFERSIZE		<p>Transfer size in number of transfers. A write to this field sets the size of the transfer when the DMA Controller is the flow controller. The transfer size value must be set before the channel is enabled. Transfer size is updated as data transfers are completed.</p> <p>A read from this field indicates the number of transfers completed on the destination bus. Reading the register when the channel is active does not give useful information because by the time that the software has processed the value read, the channel might have progressed. It is intended to be used only when a channel is enabled and then disabled.</p> <p>The transfer size value is not used if the DMA Controller is not the flow controller.</p>	0x0	R/W
14:12	SBSIZE		<p>Source burst size. Indicates the number of transfers that make up a source burst. This value must be set to the burst size of the source peripheral, or if the source is memory, to the memory boundary size (see Figure 3). The burst size is the amount of data that is transferred when the BREQ signal goes active in the source peripheral.</p>	0x0	R/W
		0x0	Source burst size = 1		
		0x1	Source burst size = 4		
		0x2	Source burst size = 8		
		0x3	Source burst size = 16		
		0x4	Source burst size = 32		
		0x5	Source burst size = 64		
		0x6	Source burst size = 128		
		0x7	Source burst size = 256		
17:15	DBSIZE		<p>Destination burst size. Indicates the number of transfers that make up a destination burst transfer request. This value must be set to the burst size of the destination peripheral or, if the destination is memory, to the memory boundary size. The burst size is the amount of data that is transferred when the BREQ signal goes active in the destination peripheral.</p>	0x0	R/W
		0x0	Destination burst size = 1		
		0x1	Destination burst size = 4		
		0x2	Destination burst size = 8		
		0x3	Destination burst size = 16		
		0x4	Destination burst size = 32		
		0x5	Destination burst size = 64		
		0x6	Destination burst size = 128		
		0x7	Destination burst size = 256		

Table 271. DMA Channel Control registers (CONTROL[0:7], 0x4000 210C (CONTROL0) to 0x4000 21EC (CONTROL7)) bit description ...continued

Bit	Symbol	Value	Description	Reset value	Access
20:18	SWIDTH		Source transfer width. Transfers wider than the AHB master bus width are illegal. The source and destination widths can be different from each other. The hardware automatically packs and unpacks the data as required. 0x3 to 0x7 - Reserved.	0x0	R/W
		0x0	Byte (8-bit)		
		0x1	Halfword (16-bit)		
		0x2	Word (32-bit)		
23:21	DWIDTH		Destination transfer width. Transfers wider than the AHB master bus width are not supported. The source and destination widths can be different from each other. The hardware automatically packs and unpacks the data as required. 0x3 to 0x7 - Reserved.	0x0	R/W
		0x0	Byte (8-bit)		
		0x1	Halfword (16-bit)		
		0x2	Word (32-bit)		
24	S		Source AHB master select:	0	R/W
		0	AHB Master 0 selected for source transfer.		
		1	AHB Master 1 selected for source transfer.		
25	D		Destination AHB master select: Remark: Only Master1 can access peripherals. Master0 can only access memory.	0	R/W
		0	AHB Master 0 selected for destination transfer.		
		1	AHB Master 1 selected for destination transfer.		
26	SI		Source increment:	0	R/W
		0	The source address is not incremented after each transfer.		
27	DI		Destination increment:	0	R/W
		0	The destination address is not incremented after each transfer.		
28	PROT1		This information is provided to the peripheral during a DMA bus access and indicates that the access is in user mode or privileged mode.	0	R/W
		0	User mode		
		1	Privileged mode		
29	PROT2		This information is provided to the peripheral during a DMA bus access and indicates to the peripheral that the access is bufferable or not bufferable.	0	R/W
		0	Not bufferable		
30	PROT3		This information is provided to the peripheral during a DMA bus access and indicates to the peripheral that the access is cacheable or not cacheable.	0	R/W
		0	Not cacheable		
		1	Cacheable		

Table 271. DMA Channel Control registers (CONTROL[0:7], 0x4000 210C (CONTROL0) to 0x4000 21EC (CONTROL7)) bit description ...continued

Bit	Symbol	Value	Description	Reset value	Access
31	I		Terminal count interrupt enable bit.	0	R/W
		0	The terminal count interrupt is disabled.		
		1	The terminal count interrupt is enabled.		

19.6.19.1 Protection and access information

AHB access information is provided to the source and/or destination peripherals when a transfer occurs. The transfer information is provided by programming the DMA channel (the PROT bits of the CONTROL Register, and the LOCK bit of the CONFIG Register). These bits are programmed by software and can be used by peripherals.

19.6.20 Channel Configuration registers

The eight CONFIG Registers are read/write with the exception of bit[17] which is read-only. Used these to configure the DMA channel. The registers are not updated when a new LLI is requested.

Table 272. DMA Channel Configuration registers (CONFIG[0:7], 0x4000 2110 (CONFIG0) to 0x4000 21F0 (CONFIG7)) bit description

Bit	Symbol	Value	Description	Reset value	Access
0	E		Channel enable. Reading this bit indicates whether a channel is currently enabled or disabled: The Channel Enable bit status can also be found by reading the ENBLDCHNS Register. A channel can be disabled by clearing the Enable bit. This causes the current AHB transfer (if one is in progress) to complete and the channel is then disabled. Any data in the FIFO of the relevant channel is lost. Restarting the channel by setting the Channel Enable bit has unpredictable effects, the channel must be fully re-initialized. The channel is also disabled, and Channel Enable bit cleared, when the last LLI is reached, the DMA transfer is completed, or if a channel error is encountered. If a channel must be disabled without losing data in the FIFO, the Halt bit must be set so that further DMA requests are ignored. The Active bit must then be polled until it reaches 0, indicating that there is no data left in the FIFO. Finally, the Channel Enable bit can be cleared. Remark: The GPDMA pre-loads the data from the source memory as soon as the channel is enabled. The data pre-loading occurs independently of receiving a DMA transfer request.	0	R/W
		0	Channel disabled.		
		1	Channel enabled.		

Table 272. DMA Channel Configuration registers (CONFIG[0:7], 0x4000 2110 (CONFIG0) to 0x4000 21F0 (CONFIG7))
 bit description ...continued

Bit	Symbol	Value	Description	Reset value	Access
5:1	SRCPERIPHERAL		Source peripheral. This value selects the DMA source request peripheral. This field is ignored if the source of the transfer is from memory. See Table 252 for details.		R/W
		0x0	SPIFI/SCT match3/Timer3 match 1		
		0x1	Timer0 match 0/USART0 transmit/AES in		
		0x2	Timer0 match 1/USART0 receive/AES out		
		0x3	Timer1 match 0/UART1 transmit/I2S1 DMA request 1/SSP1 transmit		
		0x4	Timer1 match 1/UART1 receive/I2S1 DMA request 2/SSP1 receive		
		0x5	Timer2 match 0/USART2 transmit/SSP1 transmit		
		0x6	Timer2 match 1/USART2 receive/SSP1 receive		
		0x7	Timer3 match 0/USART3 transmit/SCT DMA request 0/VADC write		
		0x8	Timer3 match 1/USART3 receive/SCT DMA request 1/VADC read		
		0x9	SSP0 receive/I2S0 DMA request 1/SCT DMA request 1		
		0xA	SSP0 transmit/I2S0 DMA request 2/SCT DMA request 0		
		0xB	SSP1 receive/USART0 transmit		
		0xC	SSP1 transmit/USART0 receive		
		0xD	ADC0/AES in/SSP1 receive/USART3 receive		
		0xE	ADC1/AES out/SSP1 transmit/USART3 transmit		
		0xF	DAC/SCT match 3/Timer3 match 0		

Table 272. DMA Channel Configuration registers (CONFIG[0:7], 0x4000 2110 (CONFIG0) to 0x4000 21F0 (CONFIG7)) bit description ...continued

Bit	Symbol	Value	Description	Reset value	Access
10:6	DESTPERIPHERAL		Destination peripheral. This value selects the DMA destination request peripheral. This field is ignored if the destination of the transfer is to memory. See Table 252 for details.		R/W
		0x0	SPIFI/SCT match3/Timer3 match 1		
		0x1	Timer0 match 0/USART0 transmit/AES in		
		0x2	Timer0 match 1/USART0 receive/AES out		
		0x3	Timer1 match 0/UART1 transmit/I2S1 DMA request 1/SSP1 transmit		
		0x4	Timer1 match 1/UART1 receive/I2S1 DMA request 2/SSP1 receive		
		0x5	Timer2 match 0/USART2 transmit/SSP1 transmit		
		0x6	Timer2 match 1/USART2 receive/SSP1 receive		
		0x7	Timer3 match 0/USART3 transmit/SCT DMA request 0/VADC write		
		0x8	Timer3 match 1/USART3 receive/SCT DMA request 1/VADC read		
		0x9	SSP0 receive/I2S0 DMA request 1/SCT DMA request 1		
		0xA	SSP0 transmit/I2S0 DMA request 2/SCT DMA request 0		
		0xB	SSP1 receive/USART0 transmit		
		0xC	SSP1 transmit/USART0 receive		
		0xD	ADC0/AES in/SSP1 receive/USART3 receive		
		0xE	ADC1/AES out/SSP1 transmit/USART3 transmit		
		0xF	DAC/SCT match 3/Timer3 match 0		
13:11	FLOWCNTRL		Flow control and transfer type. This value indicates the flow controller and transfer type. The flow controller can be the DMA Controller, the source peripheral, or the destination peripheral. The transfer type can be memory-to-memory, memory-to-peripheral, peripheral-to-memory, or peripheral-to-peripheral. Refer to Table 273 for the encoding of this field.		R/W
		0x0	Memory to memory (DMA control)		
		0x1	Memory to peripheral (DMA control)		
		0x2	Peripheral to memory (DMA control)		
		0x3	Source peripheral to destination peripheral (DMA control)		
		0x4	Source peripheral to destination peripheral (destination control)		
		0x5	Memory to peripheral (peripheral control)		
		0x6	Peripheral to memory (peripheral control)		
		0x7	Source peripheral to destination peripheral (source control)		
14	IE		Interrupt error mask. When cleared, this bit masks out the error interrupt of the relevant channel.		R/W
15	ITC		Terminal count interrupt mask. When cleared, this bit masks out the terminal count interrupt of the relevant channel.		R/W
16	L		Lock. When set, this bit enables locked transfers.		R/W

Table 272. DMA Channel Configuration registers (CONFIG[0:7], 0x4000 2110 (CONFIG0) to 0x4000 21F0 (CONFIG7)) bit description ...continued

Bit	Symbol	Value	Description	Reset value	Access
17	A		Active: 0 = there is no data in the FIFO of the channel. 1 = the channel FIFO has data. This value can be used with the Halt and Channel Enable bits to cleanly disable a DMA channel. This is a read-only bit.		RO
18	H		Halt: 0 = enable DMA requests. 1 = ignore further source DMA requests. The contents of the channel FIFO are drained. This value can be used with the Active and Channel Enable bits to cleanly disable a DMA channel.		R/W
		0	Enable DMA requests.		
		1	Ignore further source DMA requests.		
31:19	-		Reserved, do not modify, masked on read.		-

19.6.20.1 Lock control

The lock control may set the lock bit by writing a 1 to bit 16 of the CONFIG Register. When a burst occurs, the AHB arbiter will not de-grant the master during the burst until the lock is deasserted. The DMA Controller can be locked for a a single burst such as a long source fetch burst or a long destination drain burst. The DMA Controller does not usually assert the lock continuously for a source fetch burst followed by a destination drain burst.

There are situations when the DMA Controller asserts the lock for source transfers followed by destination transfers. This is possible when internal conditions in the DMA Controller permit it to perform a source fetch followed by a destination drain back-to-back.

19.6.20.2 Flow control and transfer type

[Table 273](#) lists the bit values of the three flow control and transfer type bits identified in [Table 272](#).

Table 273. Flow control and transfer type bits

Bit value	Transfer type	Controller
000	Memory to memory	DMA
001	Memory to peripheral	DMA
010	Peripheral to memory	DMA
011	Source peripheral to destination peripheral	DMA
100	Source peripheral to destination peripheral	Destination peripheral
101	Memory to peripheral	Peripheral
110	Peripheral to memory	Peripheral
111	Source peripheral to destination peripheral	Source peripheral

19.7 Functional description

19.7.1 DMA controller functional description

The DMA Controller enables peripheral-to-memory, memory-to-peripheral, peripheral-to-peripheral, and memory-to-memory transactions. Each DMA stream provides unidirectional serial DMA transfers for a single source and destination. For example, a bidirectional port requires one stream for transmit and one for receive. The source and destination areas can each be either a memory region or a peripheral, and can be accessed through the AHB master. [Figure 42](#) shows a block diagram of the DMA Controller.

The functions of the DMA Controller are described in the following sections.

19.7.1.1 AHB slave interface

All transactions to DMA Controller registers on the AHB slave interface are 32 bits wide. Eight bit and 16-bit accesses are not supported and will result in an exception.

19.7.1.2 Control logic and register bank

The register block stores data written or to be read across the AHB interface.

19.7.1.3 DMA request and response interface

See DMA Interface description for information on the DMA request and response interface.

19.7.1.4 Channel logic and channel register bank

The channel logic and channel register bank contains registers and logic required for each DMA channel.

19.7.1.5 Interrupt request

The interrupt request generates the interrupt to the ARM processor.

19.7.1.6 AHB master interface

The DMA Controller contains two AHB master interfaces. Each AHB master is capable of dealing with all types of AHB transactions, including:

- Split, retry, and error responses from slaves. If a peripheral performs a split or retry, the DMA Controller stalls and waits until the transaction can complete.
- Locked transfers for source and destination of each stream.
- Setting of protection bits for transfers on each stream.

19.7.1.6.1 Bus and transfer widths

The physical width of the AHB bus is 32 bits. Source and destination transfers can be of differing widths and can be the same width or narrower than the physical bus width. The DMA Controller packs or unpacks data as appropriate.

19.7.1.6.2 Endian behavior

The DMA Controller can cope with both little-endian and big-endian addressing. Software can set the endianness of each AHB master individually.

Internally the DMA Controller treats all data as a stream of bytes instead of 16-bit or 32-bit quantities. This means that when performing mixed-endian activity, where the endianness of the source and destination are different, byte swapping of the data within the 32-bit data bus is observed.

Note: If byte swapping is not required, then use of different endianness between the source and destination addresses must be avoided. [Table 274](#) shows endian behavior for different source and destination combinations.

Table 274. Endian behavior

Source endian	Destination endian	Source width	Destination width	Source transfer no/byte lane	Source data	Destination transfer no/byte lane	Destination data
Little	Little	8	8	1/[7:0]	21	1/[7:0]	21212121
				2/[15:8]	43	2/[15:8]	43434343
				3/[23:16]	65	3/[23:16]	65656565
				4/[31:24]	87	4/[31:24]	87878787
Little	Little	8	16	1/[7:0]	21	1/[15:0]	43214321
				2/[15:8]	43	2/[31:16]	87658765
				3/[23:16]	65		
				4/[31:24]	87		
Little	Little	8	32	1/[7:0]	21	1/[31:0]	87654321
				2/[15:8]	43		
				3/[23:16]	65		
				4/[31:24]	87		
Little	Little	16	8	1/[7:0]	21	1/[7:0]	21212121
				1/[15:8]	43	2/[15:8]	43434343
				2/[23:16]	65	3/[23:16]	65656565
				2/[31:24]	87	4/[31:24]	87878787
Little	Little	16	16	1/[7:0]	21	1/[15:0]	43214321
				1/[15:8]	43	2/[31:16]	87658765
				2/[23:16]	65		
				2/[31:24]	87		
Little	Little	16	32	1/[7:0]	21	1/[31:0]	87654321
				1/[15:8]	43		
				2/[23:16]	65		
				2/[31:24]	87		
Little	Little	32	8	1/[7:0]	21	1/[7:0]	21212121
				1/[15:8]	43	2/[15:8]	43434343
				1/[23:16]	65	3/[23:16]	65656565
				1/[31:24]	87	4/[31:24]	87878787
Little	Little	32	16	1/[7:0]	21	1/[15:0]	43214321
				1/[15:8]	43	2/[31:16]	87658765
				1/[23:16]	65		
				1/[31:24]	87		

Table 274. Endian behavior ...continued

Source endian	Destination endian	Source width	Destination width	Source transfer no/byte lane	Source data	Destination transfer no/byte lane	Destination data
Little	Little	32	32	1/[7:0]	21	1/[31:0]	87654321
				1/[15:8]	43		
				1/[23:16]	65		
				1/[31:24]	87		
Big	Big	8	8	1/[31:24]	12	1/[31:24]	12121212
				2/[23:16]	34	2/[23:16]	34343434
				3/[15:8]	56	3/[15:8]	56565656
				4/[7:0]	78	4/[7:0]	78787878
Big	Big	8	16	1/[31:24]	12	1/[15:0]	12341234
				2/[23:16]	34	2/[31:16]	56785678
				3/[15:8]	56		
				4/[7:0]	78		
Big	Big	8	32	1/[31:24]	12	1/[31:0]	12345678
				2/[23:16]	34		
				3/[15:8]	56		
				4/[7:0]	78		
Big	Big	16	8	1/[31:24]	12	1/[31:24]	12121212
				1/[23:16]	34	2/[23:16]	34343434
				2/[15:8]	56	3/[15:8]	56565656
				2/[7:0]	78	4/[7:0]	78787878
Big	Big	16	16	1/[31:24]	12	1/[15:0]	12341234
				1/[23:16]	34	2/[31:16]	56785678
				2/[15:8]	56		
				2/[7:0]	78		
Big	Big	16	32	1/[31:24]	12	1/[31:0]	12345678
				1/[23:16]	34		
				2/[15:8]	56		
				2/[7:0]	78		
Big	Big	32	8	1/[31:24]	12	1/[31:24]	12121212
				1/[23:16]	34	2/[23:16]	34343434
				1/[15:8]	56	3/[15:8]	56565656
				1/[7:0]	78	4/[7:0]	78787878
Big	Big	32	16	1/[31:24]	12	1/[15:0]	12341234
				1/[23:16]	34	2/[31:16]	56785678
				1/[15:8]	56		
				1/[7:0]	78		
Big	Big	32	32	1/[31:24]	12	1/[31:0]	12345678
				1/[23:16]	34		
				1/[15:8]	56		
				1/[7:0]	78		

19.7.1.6.3 Error conditions

An error during a DMA transfer is flagged directly by the peripheral by asserting an Error response on the AHB bus during the transfer. The DMA Controller automatically disables the DMA stream after the current transfer has completed, and can optionally generate an error interrupt to the CPU. This error interrupt can be masked.

19.7.1.7 Channel hardware

Each stream is supported by a dedicated hardware channel, including source and destination controllers, as well as a FIFO. This enables better latency than a DMA controller with only a single hardware channel shared between several DMA streams and simplifies the control logic.

19.7.1.8 DMA request priority

DMA channel priority is fixed. DMA channel 0 has the highest priority and DMA channel 7 has the lowest priority.

If the DMA Controller is transferring data for the lower priority channel and then the higher priority channel goes active, it completes the number of transfers delegated to the master interface by the lower priority channel before switching over to transfer data for the higher priority channel. In the worst case this is as large as a one quadword.

It is recommended that memory-to-memory transactions use the lowest priority channel. Otherwise other AHB bus masters are prevented from accessing the bus during DMA Controller memory-to-memory transfer.

19.7.1.9 Interrupt generation

A combined interrupt output is generated as an OR function of the individual interrupt requests of the DMA Controller and is connected to the interrupt controller.

19.8 Using the DMA controller

19.8.1 Programming the DMA controller

All accesses to the DMA Controller internal register must be word (32-bit) reads and writes.

19.8.1.1 Enabling the DMA controller

To enable the DMA controller set the Enable bit in the CONFIG register.

19.8.1.2 Disabling the DMA controller

To disable the DMA controller:

- Read the ENBLDCHNS register and ensure that all the DMA channels have been disabled. If any channels are active, see Disabling a DMA channel.
- Disable the DMA controller by writing 0 to the DMA Enable bit in the CONFIG register.

19.8.1.3 Enabling a DMA channel

To enable the DMA channel set the channel enable bit in the relevant DMA channel configuration register. Note that the channel must be fully initialized before it is enabled.

19.8.1.4 Disabling a DMA channel

A DMA channel can be disabled in three ways:

- By writing directly to the channel enable bit. Any outstanding data in the FIFO's is lost if this method is used.
- By using the active and halt bits in conjunction with the channel enable bit.
- By waiting until the transfer completes. This automatically clears the channel.

Disabling a DMA channel and losing data in the FIFO

Clear the relevant channel enable bit in the relevant channel configuration register. The current AHB transfer (if one is in progress) completes and the channel is disabled. Any data in the FIFO is lost.

Disabling the DMA channel without losing data in the FIFO

- Set the halt bit in the relevant channel configuration register. This causes any future DMA request to be ignored.
- Poll the active bit in the relevant channel configuration register until it reaches 0. This bit indicates whether there is any data in the channel that has to be transferred.
- Clear the channel enable bit in the relevant channel configuration register

19.8.1.5 Setting up a new DMA transfer

To set up a new DMA transfer:

If the channel is not set aside for the DMA transaction:

1. Read the ENBLDCHNS controller register and find out which channels are inactive.
2. Choose an inactive channel that has the required priority.
3. Program the DMA controller

19.8.1.6 Halting a DMA channel

Set the halt bit in the relevant DMA channel configuration register. The current source request is serviced. Any further source DMA request is ignored until the halt bit is cleared.

19.8.1.7 Programming a DMA channel

1. Choose a free DMA channel with the priority needed. DMA channel 0 has the highest priority and DMA channel 7 the lowest priority.
2. Clear any pending interrupts on the channel to be used by writing to the IntTCClear and INTERRCLEAR register. The previous channel operation might have left interrupt active.
3. Write the source address into the CSRCADDR register.
4. Write the destination address into the CDESTADDR register.
5. Write the address of the next LLI into the CLLI register. If the transfer comprises of a single packet of data then 0 must be written into this register.
6. Write the control information into the CCONTROL register.
7. Write the channel configuration information into the CCONFIG register. If the enable bit is set then the DMA channel is automatically enabled.

19.8.2 Flow control

The peripheral that controls the length of the packet is known as the flow controller. The flow controller is usually the DMA Controller where the packet length is programmed by software before the DMA channel is enabled. If the packet length is unknown when the DMA channel is enabled, either the source or destination peripherals can be used as the flow controller.

For simple or low-performance peripherals that know the packet length (that is, when the peripheral is the flow controller), a simple way to indicate that a transaction has completed is for the peripheral to generate an interrupt and enable the processor to reprogram the DMA channel.

The transfer size value (in the CCONTROL register) is ignored if a peripheral is configured as the flow controller.

When the DMA transfer is completed:

1. The DMA Controller issues an acknowledge to the peripheral in order to indicate that the transfer has finished.
2. A TC interrupt is generated, if enabled.
3. The DMA Controller moves on to the next LLI.

The following sections describe the DMA Controller data flow sequences for the four allowed transfer types:

- Memory-to-peripheral (master 1 only).
- Peripheral-to-memory (master 1 only).
- Memory-to-memory.
- Peripheral-to-peripheral (master 1 only).

Each transfer type can have either the peripheral or the DMA Controller as the flow controller so there are eight possible control scenarios.

[Table 275](#) indicates the request signals used for each type of transfer.

Table 275. DMA request signal usage

Transfer direction	Request generator	Flow controller
Memory-to-peripheral	Peripheral	DMA Controller
Memory-to-peripheral	Peripheral	Peripheral
Peripheral-to-memory	Peripheral	DMA Controller
Peripheral-to-memory	Peripheral	Peripheral
Memory-to-memory	DMA Controller	DMA Controller
Source peripheral to destination peripheral	Source peripheral and destination peripheral	Source peripheral
Source peripheral to destination peripheral	Source peripheral and destination peripheral	Destination peripheral
Source peripheral to destination peripheral	Source peripheral and destination peripheral	DMA Controller

19.8.2.1 Peripheral-to-memory or memory-to-peripheral DMA flow

For a peripheral-to-memory or memory-to-peripheral DMA flow, the following sequence occurs:

1. Program and enable the DMA channel.
2. Wait for a DMA request.
3. The DMA Controller starts transferring data when:
 - The DMA request goes active.
 - The DMA stream has the highest pending priority.
 - The DMA Controller is the bus master of the AHB bus.
4. If an error occurs while transferring the data, an error interrupt is generated and disables the DMA stream, and the flow sequence ends.
5. Decrement the transfer count if the DMA Controller is performing the flow control.
6. If the transfer has completed (indicated by the transfer count reaching 0, if the DMA Controller is performing flow control, or by the peripheral sending a DMA request, if the peripheral is performing flow control):
 - The DMA Controller responds with a DMA acknowledge.
 - The terminal count interrupt is generated (this interrupt can be masked).
 - If the CLLI Register is not 0, then reload the CSRCADDR, CDESTADDR, CLLI, and CCONTROL registers and go back to step 2. However, if CLLI is 0, the DMA stream is disabled and the flow sequence ends.

19.8.2.2 Peripheral-to-peripheral DMA flow

For a peripheral-to-peripheral DMA flow, the following sequence occurs:

1. Program and enable the DMA channel.
2. Wait for a source DMA request.
3. The DMA Controller starts transferring data when:
 - The DMA request goes active.
 - The DMA stream has the highest pending priority.
 - The DMA Controller is the bus master of the AHB bus.
4. If an error occurs while transferring the data an error interrupt is generated, the DMA stream is disabled, and the flow sequence ends.
5. Decrement the transfer count if the DMA Controller is performing the flow control.
6. If the transfer has completed (indicated by the transfer count reaching 0 if the DMA Controller is performing flow control, or by the peripheral sending a DMA request if the peripheral is performing flow control):
 - The DMA Controller responds with a DMA acknowledge to the source peripheral.
 - Further source DMA requests are ignored.
7. When the destination DMA request goes active and there is data in the DMA Controller FIFO, transfer data into the destination peripheral.
8. If an error occurs while transferring the data, an error interrupt is generated, the DMA stream is disabled, and the flow sequence ends.
9. If the transfer has completed it is indicated by the transfer count reaching 0 if the DMA Controller is performing flow control, or by the sending a DMA request if the peripheral is performing flow control. The following happens:

- The DMA Controller responds with a DMA acknowledge to the destination peripheral.
- The terminal count interrupt is generated (this interrupt can be masked).
- If the CLLI Register is not 0, then reload the CSRCADDR, CDESTADDR, CLLI, and CCONTROL Registers and go to back to step 2. However, if CLLI is 0, the DMA stream is disabled and the flow sequence ends.

19.8.2.3 Memory-to-memory DMA flow

For a memory-to-memory DMA flow the following sequence occurs:

1. Program and enable the DMA channel.
2. Transfer data whenever the DMA channel has the highest pending priority and the DMA Controller gains mastership of the AHB bus.
3. If an error occurs while transferring the data, generate an error interrupt and disable the DMA stream.
4. Decrement the transfer count.
5. If the count has reached zero:
 - Generate a terminal count interrupt (the interrupt can be masked).
 - If the CLLI Register is not 0, then reload the CSRCADDR, CDESTADDR, CLLI, and CCONTROL Registers and go to back to step 2. However, if CLLI is 0, the DMA stream is disabled and the flow sequence ends.

Note: Memory-to-memory transfers should be programmed with a low channel priority, otherwise other DMA channels cannot access the bus until the memory-to-memory transfer has finished, or other AHB masters cannot perform any transaction.

19.8.3 Interrupt requests

Interrupt requests can be generated when an AHB error is encountered or at the end of a transfer (terminal count), after all the data corresponding to the current LLI has been transferred to the destination. The interrupts can be masked by programming bits in the relevant CCONTROL and CCONFIG Channel Registers. Interrupt status registers are provided which group the interrupt requests from all the DMA channels prior to interrupt masking (RAWINTTCSTAT and RAWINTERRSTAT), and after interrupt masking (INTTCSTAT and INTERRSTAT). The INTSTAT Register combines both the INTTCSTAT and INTERRSTAT requests into a single register to enable the source of an interrupt to be quickly found. Writing to the INTTCLEAR or the INTERRCLR Registers with a bit set HIGH enables selective clearing of interrupts.

19.8.3.1 Hardware interrupt sequence flow

When a DMA interrupt request occurs, the Interrupt Service Routine needs to:

1. Read the INTTCSTAT Register to determine whether the interrupt was generated due to the end of the transfer (terminal count). A HIGH bit indicates that the transfer completed. If more than one request is active, it is recommended that the highest priority channels be checked first.
2. Read the INTERRSTAT Register to determine whether the interrupt was generated due to an error occurring. A HIGH bit indicates that an error occurred.
3. Service the interrupt request.

4. For a terminal count interrupt, write a 1 to the relevant bit of the INTTCCLR Register. For an error interrupt write a 1 to the relevant bit of the INTERRCLR Register to clear the interrupt request.

19.8.4 Address generation

Address generation can be either incrementing or non-incrementing (address wrapping is not supported).

Some devices, especially memories, disallow burst accesses across certain address boundaries. The DMA controller assumes that this is the case with any source or destination area, which is configured for incrementing addressing. This boundary is assumed to be aligned with the specified burst size. For example, if the channel is set for 16-transfer burst to a 32-bit wide device then the boundary is 64-bytes aligned (that is address bits [5:0] equal 0). If a DMA burst is to cross one of these boundaries, then, instead of a burst, that transfer is split into separate AHB transactions.

Note: When transferring data to or from the SDRAM, the SDRAM access must always be programmed to 32 bit accesses. The SDRAM memory controller does not support AHB-INCR4 or INCR8 bursts using halfword or byte transfer-size. Start address in SDRAM should always be aligned to a burst boundary address.

19.8.4.1 Word-aligned transfers across a boundary

The channel is configured for 16-transfer bursts, each transfer 32-bits wide, to a destination for which address incrementing is enabled. The start address for the current burst is 0x0C000024, the next boundary (calculated from the burst size and transfer width) is 0x0C000040.

The transfer will be split into two AHB transactions:

- a 7-transfer burst starting at address 0x0C000024
- a 9-transfer burst starting at address 0x0C000040.

19.8.5 Scatter/gather

Scatter/gather is supported through the use of linked lists. This means that the source and destination areas do not have to occupy contiguous areas in memory. Where scatter/gather is not required, the CLLI Register must be set to 0.

The source and destination data areas are defined by a series of linked lists. Each Linked List Item (LLI) controls the transfer of one block of data, and then optionally loads another LLI to continue the DMA operation, or stops the DMA stream. The first LLI is programmed into the DMA Controller.

The data to be transferred described by a LLI (referred to as the packet of data) usually requires one or more DMA bursts (to each of the source and destination).

19.8.5.1 Linked list items

A Linked List Item (LLI) consists of four words. These words are organized in the following order:

1. CSRCADDR
2. CDESTADDR

3. CLLI
4. CCONTROL

Note: The CCONFIG DMA channel Configuration Register is not part of the linked list item.

19.8.5.1.1 Programming the DMA controller for scatter/gather DMA

To program the DMA Controller for scatter/gather DMA:

1. Write the LLIs for the complete DMA transfer to memory. Each linked list item contains four words:
 - Source address.
 - Destination address.
 - Pointer to next LLI.
 - Control word.

The last LLI has its linked list word pointer set to 0.

2. Choose a free DMA channel with the priority required. DMA channel 0 has the highest priority and DMA channel 7 the lowest priority.
3. Write the first linked list item, previously written to memory, to the relevant channel in the DMA Controller.
4. Write the channel configuration information to the channel Configuration Register and set the Channel Enable bit. The DMA Controller then transfers the first and then subsequent packets of data as each linked list item is loaded.
5. An interrupt can be generated at the end of each LLI depending on the Terminal Count bit in the CCONTROL Register. If this bit is set an interrupt is generated at the end of the relevant LLI. The interrupt request must then be serviced and the relevant bit in the INTTCLEAR Register must be set to clear the interrupt.

19.8.5.1.2 Example of scatter/gather DMA

See [Figure 43](#) for an example of an LLI. A section of memory is to be transferred to a peripheral. The addresses of each LLI entry are given, in hexadecimal, at the left-hand side of the figure. The right side of the figure shows the memory containing the data to be transferred.

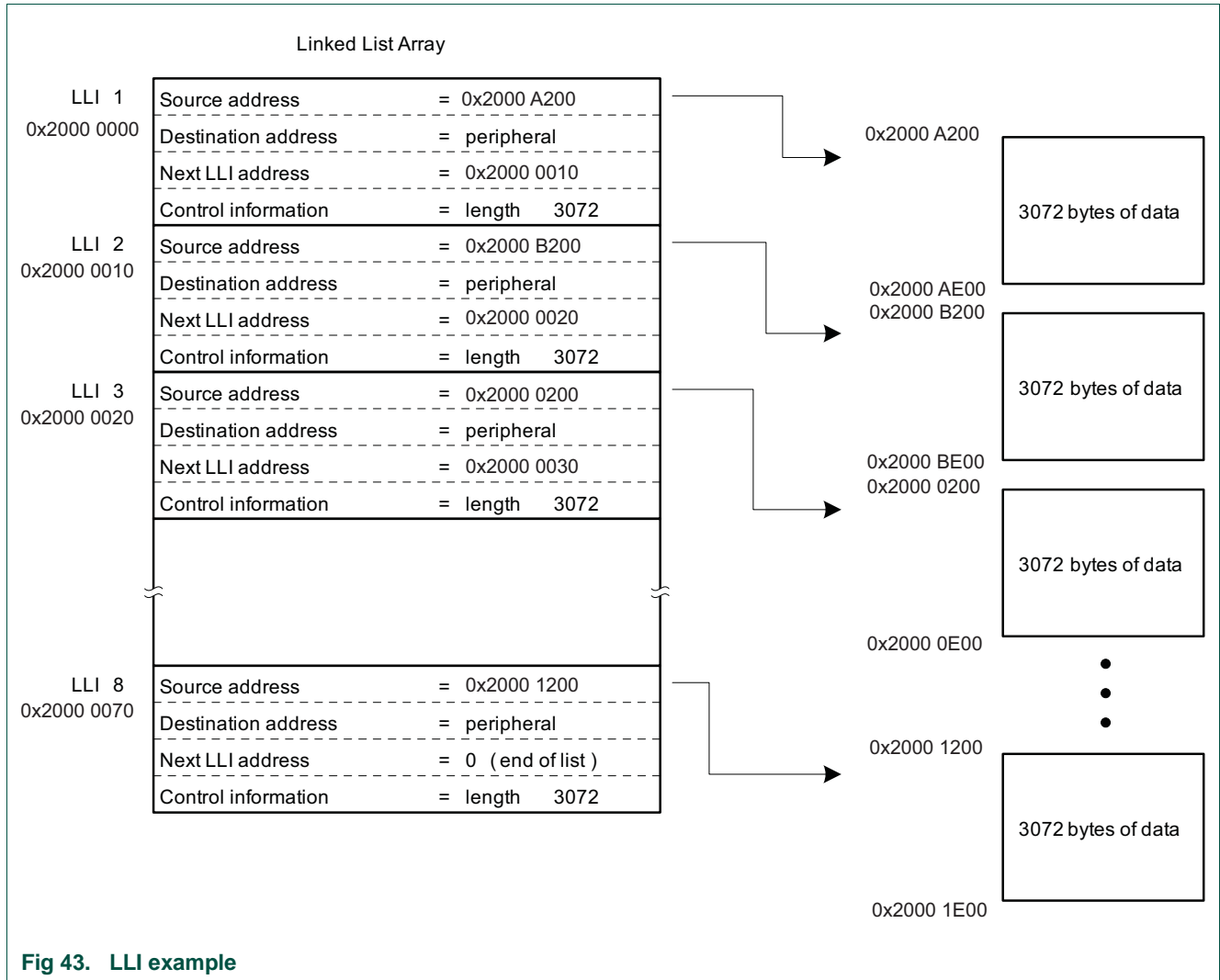

Fig 43. LLI example

The first LLI, stored at 0x2000 0000, defines the first block of data to be transferred, which is the data stored from address 0x2000 A200 to 0x2000 AE00:

- Source start address 0x2000 A200.
- Destination address set to the destination peripheral address.
- Transfer width, word (32-bit).
- Transfer size, 3072 bytes (0xC00).
- Source and destination burst sizes, 16 transfers.
- Next LLI address, 0x2000 0010.

The second LLI, stored at 0x2000 0010, describes the next block of data to be transferred:

- Source start address 0x2000 B200.
- Destination address set to the destination peripheral address.
- Transfer width, word (32-bit).
- Transfer size, 3072 bytes (0xC00).

- Source and destination burst sizes, 16 transfers.
- Next LLI address, 0x2000 0020.

A chain of descriptors is built up, each one pointing to the next in the series. To initialize the DMA stream, the first LLI, 0x2000 0000, is programmed into the DMA Controller. When the first packet of data has been transferred the next LLI is automatically loaded.

The final LLI is stored at 0x2000 0070 and contains:

- Source start address 0x2000 1200.
- Destination address set to the destination peripheral address.
- Transfer width, word (32-bit).
- Transfer size, 3072 bytes (0xC00).
- Source and destination burst sizes, 16 transfers.
- Next LLI address, 0x0.

Because the next LLI address is set to zero, this is the last descriptor, and the DMA channel is disabled after transferring the last item of data. The channel is probably set to generate an interrupt at this point to indicate to the ARM processor that the channel can be reprogrammed.

20.1 How to read this chapter

The SD/MMC card interface is available on all parts.

20.2 Basic configuration

The SD/MMC interface is configured as follows:

- The SD/MMC is reset by the SDIO_RST (reset # 20).
- The delay values on the sample and drive inputs and outputs can be adjusted using the SDDELAY register in the SYSCON block. See [Table 186](#).

Table 276. SDIO clocking and power control

	Base clock	Branch clock	Operating frequency
SDIO register interface	BASE_M3_CLK	CLK_M3_SDIO	up to 180 MHz
SDIO bit rate clock	BASE_SDIO_CLK	CLK_SDIO	Up to 52 MHz

20.3 Features

The SD/MMC card interface supports the following features:

- Secure Digital memory protocol commands.
- Secure Digital I/O protocol commands.
- Multimedia Card protocol commands.
- CE-ATA digital protocol commands.
- Command Completion signal and interrupt to processor.
- Completion Signal disable feature.
- One SD or MMC (4.4) or CE-ATA (1.1) device.
- CRC generation and error detection.
- Provides individual clock control to selectively turn ON or OFF clock to the card.
- SDIO interrupts in 1-bit and 4-bit modes.
- SDIO suspend and resume operation.
- SDIO read wait.
- Block size of 1 to 65,535 bytes
- FIFO over-run and under-run prevention by stopping card clock.
- Little-endian mode of AHB operation.
- Internal (bus mastering) DMA.
- Two FIFOs, TX and RX FIFO (FIFO depth = 32 and FIFO data width = 32 bits).

20.4 General description

The SD/MMC controller interface consists of the following main functional blocks:

- Bus Interface Unit (BIU) - Provides AHB and DMA interfaces for register and data read/writes.
- Card Interface Unit (CIU) - Handles the card protocols and provides clock management.
- Internal MCI DMA controller: AHB bus mastering DMA controller

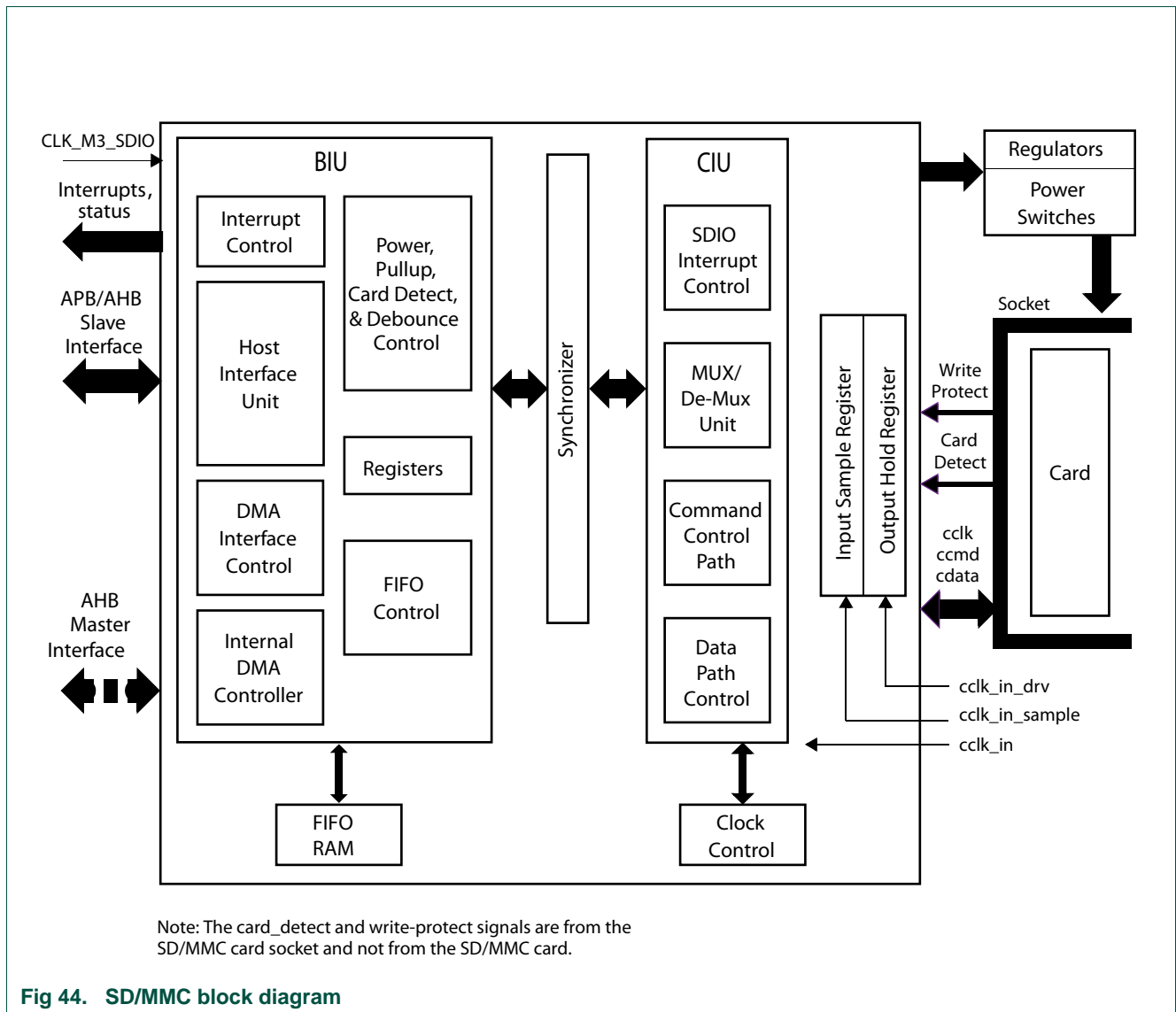

Fig 44. SD/MMC block diagram

20.5 Pin description

Table 277. SD/MMC pin description

Pin function	Direction	Description
SD_CLK	O	SD/SDIO/MMC clock
SD_CD	I	SDIO card detect for single slot
SD_WP	I	SDIO card write protect
SD_LED	O	LED On signal. This signal cautions the user not to remove the SD card while it is accessed.
SD_CMD	I/O	Command input/output
SD_D[7:0]	I/O	Data input/output for data lines DAT[7:0]
SD_VOLT[2:0]	O	SD/MMC bus voltage select output 2:0. SD/MMC General Purpose Output pins on pins SD_VOLT0, SD_VOLT1, and SD_VOLT2. These pins can be used to control an optional external regulator for the SD/MMC slot. If an external regulator is used to control the SD/MMC slot, voltage level translation will be needed between the IO pads and the SD/MMC slot.
SD_RST	O	SD/MMC reset signal for MMC4.4 card.
SD_POW	O	SD/SDIO/MMC slot power enable

20.6 Register description

Table 278. Register overview: SDMMC (base address: 0x4000 4000)

Name	Access	Address offset	Description	Reset value	Reference
CTRL	R/W	0x000	Control Register	0	Table 279
PWREN	R/W	0x004	Power Enable Register	0	Table 280
CLKDIV	R/W	0x008	Clock Divider Register	0	Table 281
CLKSRC	R/W	0x00C	SD Clock Source Register	0	Table 282
CLKENA	R/W	0x010	Clock Enable Register	0	Table 283
TMOUT	R/W	0x014	Time-out Register		Table 284
CTYPE	R/W	0x018	Card Type Register	0	Table 285
BLKSIZ	R/W	0x01C	Block Size Register	0x200	Table 286
BYTCNT	R/W	0x020	Byte Count Register	0x200	Table 287
INTMASK	R/W	0x024	Interrupt Mask Register		Table 288
CMDARG	R/W	0x028	Command Argument Register	0x00000000	Table 289
CMD	R/W	0x02C	Command Register	0x00000000	Table 290
RESP0	R	0x030	Response Register 0	0x00000000	Table 291
RESP1	R	0x034	Response Register 1	0x00000000	Table 292
RESP2	R	0x038	Response Register 2	0	Table 293
RESP3	R	0x03C	Response Register 3	0	Table 294
MINTSTS	R	0x040	Masked Interrupt Status Register	0	Table 295
RINTSTS	R/W	0x044	Raw Interrupt Status Register	0	Table 296
STATUS	R	0x048	Status Register		Table 297

Table 278. Register overview: SDMMC (base address: 0x4000 4000)

Name	Access	Address offset	Description	Reset value	Reference
FIFOTH	R/W	0x04C	FIFO Threshold Watermark Register	0x0F80 0000	Table 298
CDETECT	R	0x050	Card Detect Register		Table 299
WRTPRT	R	0x054	Write Protect Register		Table 300
-	-	0x058	Reserved	-	-
TCBCNT	R	0x05C	Transferred CIU Card Byte Count Register	0x00000000	Table 301
TBBCNT	R	0x060	Transferred Host to BIU-FIFO Byte Count Register	0	Table 302
DEBNCE	R/W	0x064	Debounce Count Register		Table 303
-	-	0x068	Reserved	-	-
-	-	0x06C	Reserved	-	-
-	-	0x070	Reserved	-	-
-	-	0x074	Reserved	-	-
RST_N	R/W	0x078	Hardware Reset		Table 304
-	-	0x07C	Reserved	-	-
BMOD	R/W	0x080	Bus Mode Register	0x00000000	Table 305
PLDMND	W	0x084	Poll Demand Register	0x00000000	Table 306
DBADDR	R/W	0x088	Descriptor List Base Address Register	0x00000000	Table 307
IDSTS	R/W	0x08C	Internal DMAC Status Register	0x00000000	Table 308
IDINTEN	R/W	0x090	Internal DMAC Interrupt Enable Register	0x00000000	Table 309
DSCADDR	R	0x094	Current Host Descriptor Address Register	0x00000000	Table 310
BUFADDR	R	0x098	Current Buffer Descriptor Address Register	0x00000000	Table 311
DATA	R/W	≥ 0x100	Data FIFO read/write; if address is equal or greater than 0x100, then FIFO is selected as long as device is selected. Address 0x100 and above are mapped to the data FIFO. More than one address is mapped to the data FIFO so that the FIFO can be accessed using bursts.		-

20.6.1 Control Register (CTRL)

Table 279. Control Register (CTRL, address 0x4000 4000) bit description

Bit	Symbol	Value	Description	Reset value
0	CONTROLLER_RESET		Controller reset. To reset controller, software should set bit to 1. This bit is auto-cleared after two AHB and two cclk_in clock cycles. This resets: <ul style="list-style-type: none"> - BIU/CIU interface - CIU and state machines - abort_read_data, send_irq_response, and read_wait bits of Control register - start_cmd bit of Command register Does not affect any registers or DMA interface, or FIFO. or host interrupts.	0
		0	No change	
		1	Reset SD/MMC controller	

Table 279. Control Register (CTRL, address 0x4000 4000) bit description

Bit	Symbol	Value	Description	Reset value
1	FIFO_RESET		Fifo reset. To reset FIFO, software should set bit to 1. This bit is auto-cleared after completion of reset operation. auto-cleared after two AHB clocks.	0
		0	No change	
		1	Reset to data FIFO To reset FIFO pointers	
2	DMA_RESET		Dma_reset. To reset DMA interface, software should set bit to 1. This bit is auto-cleared after two AHB clocks.	0
		0	No change	
		1	Reset internal DMA interface control logic	
3	-		Reserved	-
4	INT_ENABLE		Global interrupt enable/disable bit. The int port is 1 only when this bit is 1 and one or more unmasked interrupts are set.	0
		0	Disable interrupts	
		1	Enable interrupts	
5	-		Reserved. Always write this bit as 0.	0
6	READ_WAIT		Read/wait. For sending read-wait to SDIO cards.	0
		0	Clear read wait	
		1	Assert read wait	
7	SEND_IRQ_RESPONSE		Send irq response. This bit automatically clears once response is sent. To wait for MMC card interrupts, the host issues CMD40, and the SD/MMC controller waits for an interrupt response from the MMC card. In the meantime, if the host wants the SD/MMC interface to exit waiting for interrupt state, it can set this bit, at which time the SD/MMC interface command state-machine sends a CMD40 response on the bus and returns to idle state.	0
		0	No change	
		1	Send auto IRQ response	
8	ABORT_READ_DATA		Abort read data. Used in SDIO card suspend sequence.	0
		0	No change	
		1	After suspend command is issued during read-transfer, software polls card to find when suspend happened. Once suspend occurs, software sets bit to reset data state-machine, which is waiting for next block of data. This bit automatically clears once data state machine resets to idle. Used in SDIO card suspend sequence.	

Table 279. Control Register (CTRL, address 0x4000 4000) bit description

Bit	Symbol	Value	Description	Reset value
9	SEND_CCSD		Send ccsd. When set, the SD/MMC controller sends CCSD to the CE-ATA device. Software sets this bit only if current command is expecting CCS (that is, RW_BLK) and interrupts are enabled in CE-ATA device. Once the CCSD pattern is sent to device, the SD/MMC interface automatically clears send_ccsd bit. It also sets Command Done (CD) bit in RINTSTS register and generates interrupt to host if Command Done interrupt is not masked. NOTE: Once send_ccsd bit is set, it takes two card clock cycles to drive the CCSD on the CMD line. Due to this, during the boundary conditions it may happen that CCSD is sent to the CE-ATA device, even if the device signalled CCS.	0
		0	Clear bit if the SD/MMC controller does not reset the bit.	
		1	Send Command Completion Signal Disable (CCSD) to CE-ATA device	
10	SEND_AUTO_STOP_CCSD		Send auto stop ccsd. NOTE: Always set send_auto_stop_ccsd and send_ccsd bits together; send_auto_stop_ccsd should not be set independent of send_ccsd. When set, the SD/MMC interface automatically sends internally generated STOP command (CMD12) to CE-ATA device. After sending internally-generated STOP command, Auto Command Done (ACD) bit in RINTSTS is set and generates interrupt to host if Auto Command Done interrupt is not masked. After sending the CCSD, the SD/MMC interface automatically clears send_auto_stop_ccsd bit.	0
		0	Clear this bit if the SD/MMC controller does not reset the bit.	
		1	Send internally generated STOP after sending CCSD to CE-ATA device.	
11	CEATA_DEVICE_INTERRUPT_STATUS		CEATA device interrupt status. Software should appropriately write to this bit after power-on reset or any other reset to CE-ATA device. After reset, usually CE-ATA device interrupt is disabled (nIEN = 1). If the host enables CE-ATA device interrupt, then software should set this bit.	0
		0	Interrupts not enabled in CE-ATA device (nIEN = 1 in ATA control register)	
		1	Interrupts are enabled in CE-ATA device (nIEN = 0 in ATA control register)	
15:12	-		Reserved	-
16	CARD_VOLTAGE_A0		Controls the state of the SD_VOLT0 pin. SD/MMC card voltage control is not implemented.	0
17	CARD_VOLTAGE_A1		Controls the state of the SD_VOLT1 pin. SD/MMC card voltage control is not implemented.	0
18	CARD_VOLTAGE_A2		Controls the state of the SD_VOLT2 pin. SD/MMC card voltage control is not implemented.	0
23:19	-		Reserved.	0
24	-		Reserved. Always write this bit as 0.	0
25	USE_INTERNAL_DMACH		SD/MMC DMA use.	0
		0	The host performs data transfers through the slave interface	
		1	Internal DMA used for data transfer	
31:26	-		Reserved	-

20.6.2 Power Enable Register (PWREN)

Table 280. Power Enable Register (PWREN, address 0x4000 4004) bit description

Bit	Symbol	Description	Reset value
0	POWER_ENABLE	Power on/off switch for card; once power is turned on, software should wait for regulator/switch ramp-up time before trying to initialize card. 0 - power off 1 - power on Optional feature: port can be used as general-purpose output on the SD_POW pin.	0
31:1	-	Reserved	-

20.6.3 Clock Divider Register (CLKDIV)

Table 281. Clock Divider Register (CLKDIV, address 0x4000 4008) bit description

Bit	Symbol	Description	Reset value
7:0	CLK_DIVIDER0	Clock divider-0 value. Clock division is 2^n . For example, value of 0 means divide by $2^0 = 1$ (no division, bypass), value of 1 means divide by $2^1 = 2$, value of ff means divide by $2^{255} = 510$, and so on.	0
15:8	CLK_DIVIDER1	Clock divider-1 value. Clock division is 2^n . For example, value of 0 means divide by $2^0 = 1$ (no division, bypass), value of 1 means divide by $2^1 = 2$, value of ff means divide by $2^{255} = 510$, and so on. In MMC-Ver3.3-only mode, bits not implemented because only one clock divider is supported.	0
23:16	CLK_DIVIDER2	Clock divider-2 value. Clock division is 2^n . For example, value of 0 means divide by $2^0 = 1$ (no division, bypass), value of 1 means divide by $2^1 = 2$, value of ff means divide by $2^{255} = 510$, and so on. In MMC-Ver3.3-only mode, bits not implemented because only one clock divider is supported.	0
31:24	CLK_DIVIDER3	Clock divider-3 value. Clock division is 2^n . For example, value of 0 means divide by $2^0 = 1$ (no division, bypass), a value of 1 means divide by $2^1 = 2$, a value of ff means divide by $2^{255} = 510$, and so on. In MMC-Ver3.3-only mode, bits not implemented because only one clock divider is supported. divide by $2^0 = 1$ (no division, bypass), value of 1 means divide by $2^1 = 2$, value of ff means divide by $2^{255} = 510$, and so on. In MMC-Ver3.3-only mode, bits not implemented because only one clock divider is supported.	0

20.6.4 SD Clock Source Register (CLKSRC)

Table 282. SD Clock Source Register (CLKSRC, address 0x4000 400C) bit description

Bit	Symbol	Description	Reset value
1:0	CLK_SOURCE	Clock divider source for SD card. 00 - Clock divider 0 01 - Clock divider 1 10 - Clock divider 2 11 - Clock divider 3 In MMC-Ver3.3-only controller, only one clock divider supported. The cclk_out is always from clock divider 0, and this register is not implemented.	0
31:1	-	Reserved	-

20.6.5 Clock Enable Register (CLKENA)

Table 283. Clock Enable Register (CLKENA, address 0x4000 4010) bit description

Bit	Symbol	Description	Reset value
0	CCLK_ENABLE	Clock-enable control for SD card clock. One MMC card clock supported. 0 - Clock disabled 1 - Clock enabled	0
15:1	-	Reserved	-
16	CCLK_LOW_POWER	Low-power control for SD card clock. One MMC card clock supported. 0 - Non-low-power mode 1 - Low-power mode; stop clock when card in IDLE (should be normally set to only MMC and SD memory cards; for SDIO cards, if interrupts must be detected, clock should not be stopped).	0
31:17	-	Reserved	-

20.6.6 Time-out Register (TMOU)

Table 284. Time-out Register (TMOU, address 0x4000 4014) bit description

Bit	Symbol	Description	Reset value
7:0	RESPONSE_TIMEOUT	Response time-out value. Value is in number of card output clocks - cclk_out.	0x40
31:8	DATA_TIMEOUT	Value for card Data Read time-out; same value also used for Data Starvation by Host time-out. Value is in number of card output clocks - cclk_out of selected card. Starvation by Host time-out. Value is in number of card output clocks - cclk_out of selected card.	0xFFFFFFFF

20.6.7 Card Type Register (CTYPE)

Table 285. Card Type Register (CTYPE, address 0x4000 4018) bit description

Bit	Symbol	Description	Reset value
0	CARD_WIDTH0	Indicates if card is 1-bit or 4-bit: 0 - 1-bit mode 1 - 4-bit mode 1 and 4-bit modes only work when 8-bit mode in CARD_WIDTH1 is not enabled (bit 16 in this register is set to 0).	0
15:1	-	Reserved	-
16	CARD_WIDTH1	Indicates if card is 8-bit: 0 - Non 8-bit mode 1 - 8-bit mode.	0
31:17	-	Reserved	-

20.6.8 Block Size Register (BLKSIZ)

Table 286. Block Size Register (BLKSIZ, address 0x4000 401C) bit description

Bit	Symbol	Description	Reset value
15:0	BLOCK_SIZE	Block size	0x200
31:16	-	Reserved	-

20.6.9 Byte Count Register (BYTCNT)

Table 287. Byte Count Register (BYTCNT, address 0x4000 4020) bit description

Bit	Symbol	Description	Reset value
31:0	BYTE_COUNT	Number of bytes to be transferred; should be integer multiple of Block Size for block transfers. For undefined number of byte transfers, byte count should be set to 0. When byte count is set to 0, it is responsibility of host to explicitly send stop/abort command to terminate data transfer.	0x200

20.6.10 Interrupt Mask Register (INTMASK)

Table 288. Interrupt Mask Register (INTMASK, address 0x4000 4024) bit description

Bit	Symbol	Description	Reset value
0	CDET	Card detect. Bits used to mask unwanted interrupts. Value of 0 masks interrupt; value of 1 enables interrupt.	0
1	RE	Response error. Bits used to mask unwanted interrupts. Value of 0 masks interrupt; value of 1 enables interrupt.	0
2	CDONE	Command done. Bits used to mask unwanted interrupts. Value of 0 masks interrupt; value of 1 enables interrupt.	0
3	DTO	Data transfer over. Bits used to mask unwanted interrupts. Value of 0 masks interrupt; value of 1 enables interrupt.	0

Table 288. Interrupt Mask Register (INTMASK, address 0x4000 4024) bit description

Bit	Symbol	Description	Reset value
4	TXDR	Transmit FIFO data request. Bits used to mask unwanted interrupts. Value of 0 masks interrupt; value of 1 enables interrupt.	0
5	RXDR	Receive FIFO data request. Bits used to mask unwanted interrupts. Value of 0 masks interrupt; value of 1 enables interrupt.	0
6	RCRC	Response CRC error. Bits used to mask unwanted interrupts. Value of 0 masks interrupt; value of 1 enables interrupt.	0
7	DCRC	Data CRC error. Bits used to mask unwanted interrupts. Value of 0 masks interrupt; value of 1 enables interrupt.	0
8	RTO	Response time-out. Bits used to mask unwanted interrupts. Value of 0 masks interrupt; value of 1 enables interrupt.	0
9	DRTO	Data read time-out. Bits used to mask unwanted interrupts. Value of 0 masks interrupt; value of 1 enables interrupt.	0
10	HTO	Data starvation-by-host time-out (HTO) /Volt_switch_int. Bits used to mask unwanted interrupts. Value of 0 masks interrupt; value of 1 enables interrupt.	0
11	FRUN	FIFO underrun/overflow error. Bits used to mask unwanted interrupts. Value of 0 masks interrupt; value of 1 enables interrupt.	0
12	HLE	Hardware locked write error. Bits used to mask unwanted interrupts. Value of 0 masks interrupt; value of 1 enables interrupt.	0
13	SBE	Start-bit error. Bits used to mask unwanted interrupts. Value of 0 masks interrupt; value of 1 enables interrupt.	0
14	ACD	Auto command done. Bits used to mask unwanted interrupts. Value of 0 masks interrupt; value of 1 enables interrupt.	0
15	EBE	End-bit error (read)/Write no CRC. Bits used to mask unwanted interrupts. Value of 0 masks interrupt; value of 1 enables interrupt.	0
16	SDIO_INT_MASK	Mask SDIO interrupt. When masked, SDIO interrupt detection for card is disabled. A 0 masks an interrupt, and 1 enables an interrupt. In MMC-Ver3.3-only mode, this bit is always 0.	0
31:17	-	Reserved	-

20.6.11 Command Argument Register (CMDARG)

Table 289. Command Argument Register (CMDARG, address 0x4000 4028) bit description

Bit	Symbol	Description	Reset value
31:0	CMD_ARG	Value indicates command argument to be passed to card.	0

20.6.12 Command Register (CMD)

Table 290. Command Register (CMD, address 0x4000 402C) bit description

Bit	Symbol	Value	Description	Reset value
5:0	CMD_INDEX		Command index	0
6	RESPONSE_EXPECT	0	No response expected from card	0
		1	Response expected from card	
7	RESPONSE_LENGTH	0	Short response expected from card	0
		1	Long response expected from card	
8	CHECK_RESPONSE_CRC	0	Do not check response CRC	0
		1	Check response CRC	
9	DATA_EXPECTED	0	No data transfer expected (read/write)	0
		1	Data transfer expected (read/write)	
10	READ_WRITE	0	Read from card	0
		1	Write to card	
11	TRANSFER_MODE	0	Block data transfer command	0
		1	Stream data transfer command	
12	SEND_AUTO_STOP	0	No stop command sent at end of data transfer	0
		1	Send stop command at end of data transfer	
13	WAIT_PRVDATA_COMPLETE	0	Send command at once, even if previous data transfer has not completed.	0
		1	Wait for previous data transfer completion before sending command.	

Table 290. Command Register (CMD, address 0x4000 402C) bit description

Bit	Symbol	Value	Description	Reset value
14	STOP_ABORT_CMD		Stop abort cmd. When open-ended or predefined data transfer is in progress, and host issues stop or abort command to stop data transfer, bit should be set so that command/data state-machines of CIU can return correctly to idle state. This is also applicable for Boot mode transfers. To Abort boot mode, this bit should be set along with CMD[26] = disable_boot.	0
		0	Neither stop nor abort command to stop current data transfer in progress. If abort is sent to function-number currently selected or not in data-transfer mode, then bit should be set to 0.	
		1	Stop or abort command intended to stop current data transfer in progress.	
15	SEND_INITIALIZATION		Send initialization. After power on, 80 clocks must be sent to card for initialization before sending any commands to card. Bit should be set while sending first command to card so that controller will initialize clocks before sending command to card. This bit should not be set for either of the boot modes (alternate or mandatory).	0
		0	Do not send initialization sequence (80 clocks of 1) before sending this command.	
		1	Send initialization sequence before sending this command.	
20:16	-		Reserved. Always write as 0.	0
21	UPDATE_CLOCK_REGISTERS_ONLY		Update clock registers only. Following register values transferred into card clock domain: CLKDIV, CLRSRC, CLKENA. Changes card clocks (change frequency, truncate off or on, and set low-frequency mode); provided in order to change clock frequency or stop clock without having to send command to cards. During normal command sequence, when update_clock_registers_only = 0, following control registers are transferred from BIU to CIU: CMD, CMDARG, TMOU, CTYPE, BLKSIZ, BYTCNT. CIU uses new register values for new command sequence to card(s). When bit is set, there are no Command Done interrupts because no command is sent to SD_MMC_CEATA cards.	0
		0	Normal command sequence	
		1	Do not send commands, just update clock register value into card clock domain	
22	READ_CEATA_DEVICE		Read ceata device. Software should set this bit to indicate that CE-ATA device is being accessed for read transfer. This bit is used to disable read data time-out indication while performing CE-ATA read transfers. Maximum value of I/O transmission delay can be no less than 10 seconds. The SD/MMC interface should not indicate read data time-out while waiting for data from CE-ATA device.	0
		0	Host is not performing read access (RW_REG or RW_BLK) towards CE-ATA device.	
		1	Host is performing read access (RW_REG or RW_BLK) towards CE-ATA device.	

Table 290. Command Register (CMD, address 0x4000 402C) bit description

Bit	Symbol	Value	Description	Reset value
23	CCS_EXPECTED		CCS expected. If the command expects Command Completion Signal (CCS) from the CE-ATA device, the software should set this control bit. The SD/MMC controller sets the Data Transfer Over (DTO) bit in the RINTSTS register and generates an interrupt to the host if the Data Transfer Over interrupt is not masked.	0
		0	Interrupts are not enabled in CE-ATA device (nIEN = 1 in ATA control register), or command does not expect CCS from device.	
		1	Interrupts are enabled in CE-ATA device (nIEN = 0), and RW_BLK command expects command completion signal from CE-ATA device.	
24	ENABLE_BOOT		Enable Boot - this bit should be set only for mandatory boot mode. When Software sets this bit along with start_cmd, CIU starts the boot sequence for the corresponding card by asserting the CMD line low. Do NOT set disable_boot and enable_boot together.	0
25	EXPECT_BOOT_ACK		Expect Boot Acknowledge. When Software sets this bit along with enable_boot, CIU expects a boot acknowledge start pattern of 0-1-0 from the selected card.	0
26	DISABLE_BOOT		Disable Boot. When software sets this bit along with start_cmd, CIU terminates the boot operation. Do NOT set disable_boot and enable_boot together.	0
27	BOOT_MODE		Boot Mode	0
		0	Mandatory Boot operation	
		1	Alternate Boot operation	
28	VOLT_SWITCH		Voltage switch bit	0
		0	No voltage switching	
		1	Voltage switching enabled; must be set for CMD11 only	
30:29	-		Reserved	
31	START_CMD		Start command. Once command is taken by CIU, this bit is cleared. When bit is set, host should not attempt to write to any command registers. If write is attempted, hardware lock error is set in raw interrupt register. Once command is sent and response is received from SD_MMC_CEATA cards, Command Done bit is set in the raw interrupt register.	

20.6.13 Response Register 0 (RESP0)

Table 291. Response Register 0 (RESP0, address 0x4000 4030) bit description

Bit	Symbol	Description	Reset value
31:0	RESPONSE0	Bit[31:0] of response	0

20.6.14 Response Register 1 (RESP1)

Table 292. Response Register 1 (RESP1, address 0x4000 4034) bit description

Bit	Symbol	Description	Reset value
31:0	RESPONSE1	Register represents bit[63:32] of long response. When CIU sends auto-stop command, then response is saved in register. Response for previous command sent by host is still preserved in Response 0 register. Additional auto-stop issued only for data transfer commands, and response type is always short for them.	0

20.6.15 Response Register 2 (RESP2)

Table 293. Response Register 2 (RESP2, address 0x4000 4038) bit description

Bit	Symbol	Description	Reset value
31:0	RESPONSE2	Bit[95:64] of long response	0

20.6.16 Response Register 3 (RESP3)

Table 294. Response Register 3 (RESP3, address 0x4000 403C) bit description

Bit	Symbol	Description	Reset value
31:0	RESPONSE3	Bit[127:96] of long response	0

20.6.17 Masked Interrupt Status Register (MINTSTS)

Table 295. Masked Interrupt Status Register (MINTSTS, address 0x4000 4040) bit description

Bit	Symbol	Description	Reset value
0	CDET	Card detect. Interrupt enabled only if corresponding bit in interrupt mask register is set.	0
1	RE	Response error. Interrupt enabled only if corresponding bit in interrupt mask register is set.	0
2	CDONE	Command done. Interrupt enabled only if corresponding bit in interrupt mask register is set.	0
3	DTO	Data transfer over. Interrupt enabled only if corresponding bit in interrupt mask register is set.	0
4	TXDR	Transmit FIFO data request. Interrupt enabled only if corresponding bit in interrupt mask register is set.	0
5	RXDR	Receive FIFO data request. Interrupt enabled only if corresponding bit in interrupt mask register is set.	0
6	RCRC	Response CRC error. Interrupt enabled only if corresponding bit in interrupt mask register is set.	0
7	DCRC	Data CRC error. Interrupt enabled only if corresponding bit in interrupt mask register is set.	0
8	RTO	Response time-out. Interrupt enabled only if corresponding bit in interrupt mask register is set.	0

Table 295. Masked Interrupt Status Register (MINTSTS, address 0x4000 4040) bit description

Bit	Symbol	Description	Reset value
9	DRTO	Data read time-out. Interrupt enabled only if corresponding bit in interrupt mask register is set.	0
10	HTO	Data starvation-by-host time-out (HTO). Interrupt enabled only if corresponding bit in interrupt mask register is set.	0
11	FRUN	FIFO underrun/overflow error. Interrupt enabled only if corresponding bit in interrupt mask register is set.	0
12	HLE	Hardware locked write error. Interrupt enabled only if corresponding bit in interrupt mask register is set.	0
13	SBE	Start-bit error. Interrupt enabled only if corresponding bit in interrupt mask register is set.	0
14	ACD	Auto command done. Interrupt enabled only if corresponding bit in interrupt mask register is set.	0
15	EBE	End-bit error (read)/write no CRC. Interrupt enabled only if corresponding bit in interrupt mask register is set.	0
16	SDIO_INTERRUPT	Interrupt from SDIO card. SDIO interrupt for card enabled only if corresponding sdio_int_mask bit is set in Interrupt mask register (mask bit 1 enables interrupt; 0 masks interrupt). 0 - No SDIO interrupt from card 1 - SDIO interrupt from card In MMC-Ver3.3-only mode, this bit is always 0.	-
31:17	-	Reserved	-

20.6.18 Raw Interrupt Status Register (RINTSTS)

Table 296. Raw Interrupt Status Register (RINTSTS, address 0x4000 4044) bit description

Bit	Symbol	Description	Reset value
0	CDET	Card detect. Writes to bits clear status bit. Value of 1 clears status bit, and value of 0 leaves bit intact. Bits are logged regardless of interrupt mask status.	0
1	RE	Response error. Writes to bits clear status bit. Value of 1 clears status bit, and value of 0 leaves bit intact. Bits are logged regardless of interrupt mask status.	0
2	CDONE	Command done. Writes to bits clear status bit. Value of 1 clears status bit, and value of 0 leaves bit intact. Bits are logged regardless of interrupt mask status.	0
3	DTO	Data transfer over. Writes to bits clear status bit. Value of 1 clears status bit, and value of 0 leaves bit intact. Bits are logged regardless of interrupt mask status.	0
4	TXDR	Transmit FIFO data request. Writes to bits clear status bit. Value of 1 clears status bit, and value of 0 leaves bit intact. Bits are logged regardless of interrupt mask status.	0
5	RXDR	Receive FIFO data request. Writes to bits clear status bit. Value of 1 clears status bit, and value of 0 leaves bit intact. Bits are logged regardless of interrupt mask status.	0

Table 296. Raw Interrupt Status Register (RINTSTS, address 0x4000 4044) bit description

Bit	Symbol	Description	Reset value
6	RCRC	Response CRC error. Writes to bits clear status bit. Value of 1 clears status bit, and value of 0 leaves bit intact. Bits are logged regardless of interrupt mask status.	0
7	DCRC	Data CRC error. Writes to bits clear status bit. Value of 1 clears status bit, and value of 0 leaves bit intact. Bits are logged regardless of interrupt mask status.	0
8	RTO_BAR	Response time-out (RTO)/Boot Ack Received (BAR). Writes to bits clear status bit. Value of 1 clears status bit, and value of 0 leaves bit intact. Bits are logged regardless of interrupt mask status.	0
9	DRTO_BDS	Data read time-out (DRTO)/Boot Data Start (BDS). Writes to bits clear status bit. Value of 1 clears status bit, and value of 0 leaves bit intact. Bits are logged regardless of interrupt mask status.	0
10	HTO	Data starvation-by-host time-out (HTO). Writes to bits clear status bit. Value of 1 clears status bit, and value of 0 leaves bit intact. Bits are logged regardless of interrupt mask status./Volt_switch_int	0
11	FRUN	FIFO underrun/overrun error. Writes to bits clear status bit. Value of 1 clears status bit, and value of 0 leaves bit intact. Bits are logged regardless of interrupt mask status.	0
12	HLE	Hardware locked write error. Writes to bits clear status bit. Value of 1 clears status bit, and value of 0 leaves bit intact. Bits are logged regardless of interrupt mask status.	0
13	SBE	Start-bit error. Writes to bits clear status bit. Value of 1 clears status bit, and value of 0 leaves bit intact. Bits are logged regardless of interrupt mask status.	0
14	ACD	Auto command done. Writes to bits clear status bit. Value of 1 clears status bit, and value of 0 leaves bit intact. Bits are logged regardless of interrupt mask status.	0
15	EBE	End-bit error (read)/write no CRC. Writes to bits clear status bit. Value of 1 clears status bit, and value of 0 leaves bit intact. Bits are logged regardless of interrupt mask status.	0
16	SDIO_INTERRUPT	Interrupt from SDIO card. Writes to these bits clear them. Value of 1 clears bit and 0 leaves bit intact. 0 - No SDIO interrupt from card 1 - SDIO interrupt from card In MMC-Ver3.3-only mode, bits always 0. Bits are logged regardless of interrupt-mask status.	0
31:17	-	Reserved.	-

20.6.19 Status Register (STATUS)

Table 297. Status Register (STATUS, address 0x4000 4048) bit description

Bit	Symbol	Description	Reset value
0	FIFO_RX_WATERMARK	FIFO reached Receive watermark level; not qualified with data transfer.	0
1	FIFO_TX_WATERMARK	FIFO reached Transmit watermark level; not qualified with data transfer.	1
2	FIFO_EMPTY	FIFO is empty status	1
3	FIFO_FULL	FIFO is full status	0
7:4	CMDFSMSTATES	<p>Command FSM states:</p> <ul style="list-style-type: none"> 0 - Idle 1 - Send init sequence 2 - Tx cmd start bit 3 - Tx cmd tx bit 4 - Tx cmd index + arg 5 - Tx cmd crc7 6 - Tx cmd end bit 7 - Rx resp start bit 8 - Rx resp IRQ response 9 - Rx resp tx bit 10 - Rx resp cmd idx 11 - Rx resp data 12 - Rx resp crc7 13 - Rx resp end bit 14 - Cmd path wait NCC 15 - Wait; CMD-to-response turnaround <p>NOTE: The command FSM state is represented using 19 bits. The STATUS Register(7:4) has 4 bits to represent the command FSM states. Using these 4 bits, only 16 states can be represented. Thus three states cannot be represented in the STATUS(7:4) register. The three states that are not represented in the STATUS Register(7:4) are:</p> <ul style="list-style-type: none"> - Bit 16 - Wait for CCS - Bit 17 - Send CCSD - Bit 18 - Boot Mode <p>Due to this, while command FSM is in Wait for CCS state or Send CCSD or Boot Mode?, the Status register indicates status as 0 for the bit field 7:4.</p>	0
8	DATA_3_STATUS	<p>Raw selected card_data[3]; checks whether card is present</p> <ul style="list-style-type: none"> 0 - card not present 1 - card present 	
9	DATA_BUSY	<p>Inverted version of raw selected card_data[0]</p> <ul style="list-style-type: none"> 0 - card data not busy 1 - card data busy 	
10	DATA_STATE_MC_BUSY	Data transmit or receive state-machine is busy	1
16:11	RESPONSE_INDEX	Index of previous response, including any auto-stop sent by core.	0
29:17	FIFO_COUNT	FIFO count - Number of filled locations in FIFO	0
30	DMA_ACK	DMA acknowledge signal state	0
31	DMA_REQ	DMA request signal state	0

20.6.20 FIFO Threshold Watermark Register (FIFOTH)

Table 298. FIFO Threshold Watermark Register (FIFOTH, address 0x4000 404C) bit description

Bit	Symbol	Value	Description	Reset value
11:0	TX_WMARK		FIFO threshold watermark level when transmitting data to card. When FIFO data count is less than or equal to this number, DMA/FIFO request is raised. If Interrupt is enabled, then interrupt occurs. During end of packet, request or interrupt is generated, regardless of threshold programming. In non-DMA mode, when transmit FIFO threshold (TXDR) interrupt is enabled, then interrupt is generated instead of DMA request. During end of packet, on last interrupt, host is responsible for filling FIFO with only required remaining bytes (not before FIFO is full or after CIU completes data transfers, because FIFO may not be empty). In DMA mode, at end of packet, if last transfer is less than burst size, DMA controller does single cycles until required bytes are transferred. 12 bits - 1 bit less than FIFO-count of status register, which is 13 bits. Limitation: TX_WMark >= 1; Recommended value: TX_WMARK = 16; (means less than or equal to FIFO_DEPTH/2).	0
15:12	-		Reserved.	0
27:16	RX_WMARK		FIFO threshold watermark level when receiving data to card. When FIFO data count reaches greater than this number, DMA/FIFO request is raised. During end of packet, request is generated regardless of threshold programming in order to complete any remaining data. In non-DMA mode, when receiver FIFO threshold (RXDR) interrupt is enabled, then interrupt is generated instead of DMA request. During end of packet, interrupt is not generated if threshold programming is larger than any remaining data. It is responsibility of host to read remaining bytes on seeing Data Transfer Done interrupt. In DMA mode, at end of packet, even if remaining bytes are less than threshold, DMA request does single transfers to flush out any remaining bytes before Data Transfer Done interrupt is set. 12 bits - 1 bit less than FIFO-count of status register, which is 13 bits. Limitation: RX_WMark less than FIFO_DEPTH-2 Recommended: RX_WMARK = 15; (means greater than (FIFO_DEPTH/2) - 1) NOTE: In DMA mode during CCS time-out, the DMA does not generate the request at the end of packet, even if remaining bytes are less than threshold. In this case, there will be some data left in the FIFO. It is the responsibility of the application to reset the FIFO after the CCS time-out.	0x1F

Table 298. FIFO Threshold Watermark Register (FIFOTH, address 0x4000 404C) bit description

Bit	Symbol	Value	Description	Reset value
30:28	DMA_MTS		<p>Burst size of multiple transaction; should be programmed same as DW-DMA controller multiple-transaction-size SRC/DEST_MSIZ. The units for transfers is the H_DATA_WIDTH parameter. A single transfer (dw_dma_single assertion in case of Non DW DMA interface) would be signalled based on this value. Value should be sub-multiple of (RX_WMark + 1) and (32 - TX_WMark). For example, if FIFO_DEPTH = 16, FDATA_WIDTH = H_DATA_WIDTH Allowed combinations for MSize and TX_WMark are: MSize = 1, TX_WMARK = 1-15 MSize = 4, TX_WMark = 8 MSize = 4, TX_WMark = 4 MSize = 4, TX_WMark = 12 MSize = 8, TX_WMark = 8 MSize = 8, TX_WMark = 4. Allowed combinations for MSize and RX_WMark are: MSize = 1, RX_WMARK = 0-14 MSize = 4, RX_WMark = 3 MSize = 4, RX_WMark = 7 MSize = 4, RX_WMark = 11 MSize = 8, RX_WMark = 7 MSize = 8, RX_WMark = 11 Recommended: MSize = 8, TX_WMark = 8, RX_WMark = 7</p>	0
		0x0	1 transfer	
		0x1	4 transfers	
		0x2	8 transfers	
		0x3	16 transfers	
		0x4	32 transfers	
		0x5	64 transfers	
		0x6	128 transfers	
		0x7	256 transfers	
31	-		Reserved	

20.6.21 Card Detect Register (CDETECT)

Table 299. Card Detect Register (CDETECT, address 0x4000 4050) bit description

Bit	Symbol	Description	Reset value
0	CARD_DETECT	Card detect. 0 represents presence of card.	0
31:1	-	Reserved	-

20.6.22 Write Protect Register (WRTPRT)

Table 300. Write Protect Register (WRTPRT, address 0x4000 4054) bit description

Bit	Symbol	Description	Reset value
0	WRITE_PROTECT	Write protect. 1 represents write protection.	0
31:1	-	Reserved	-

20.6.23 Transferred CIU Card Byte Count Register (TCBCNT)

Table 301. Transferred CIU Card Byte Count Register (TCBCNT, address 0x4000 405C) bit description

Bit	Symbol	Description	Reset value
31:0	TRANS_CARD_BYTE_COUNT	Number of bytes transferred by CIU unit to card. Register should be read only after data transfer completes; during data transfer, register returns 0.	0

20.6.24 Transferred Host to BIU-FIFO Byte Count Register (TBBCNT)

Table 302. Transferred Host to BIU-FIFO Byte Count Register (TBBCNT, address 0x4000 4060) bit description

Bit	Symbol	Description	Reset value
31:0	TRANS_FIFO_BYTE_COUNT	Number of bytes transferred between Host/DMA memory and BIU FIFO.	0

20.6.25 Debounce Count Register (DEBNCE)

Table 303. Debounce Count Register (DEBNCE, address 0x4000 4064) bit description

Bit	Symbol	Description	Reset value
23:0	DEBOUNCE_COUNT	Number of host clocks (SD_CLK) used by debounce filter logic for card detect; typical debounce time is 5-25 ms.	0xFFFFFFFF
31:24	-	Reserved	

20.6.26 Hardware Reset (RST_N)

Table 304. Hardware Reset (RST_N, address 0x4000 4078) bit description

Bit	Symbol	Description	Reset value
0	CARD_RESET	Hardware reset. 1 - Active mode 0 - Reset Toggles state on SD_RST pin. This bit causes the card to enter pre-idle state, which requires it to be re-initialized.	1
31:1	-	Reserved	

20.6.27 Bus Mode Register (BMOD)

Table 305. Bus Mode Register (BMOD, address 0x4000 4080) bit description

Bit	Symbol	Value	Description	Reset value
0	SWR		Software Reset. When set, the DMA Controller resets all its internal registers. SWR is read/write. It is automatically cleared after 1 clock cycle.	0
1	FB		Fixed Burst. Controls whether the AHB Master interface performs fixed burst transfers or not. When set, the AHB will use only SINGLE, INCR4, INCR8 or INCR16 during start of normal burst transfers. When reset, the AHB will use SINGLE and INCR burst transfer operations. FB is read/write.	0
6:2	DSL		Descriptor Skip Length. Specifies the number of HWord/Word/Dword to skip between two unchained descriptors. This is applicable only for dual buffer structure. DSL is read/write.	0
7	DE		SD/MMC DMA Enable. When set, the SD/MMC DMA is enabled. DE is read/write.	
10:8	PBL		Programmable Burst Length. These bits indicate the maximum number of beats to be performed in one SD/MMC DMA transaction. The SD/MMC DMA will always attempt to burst as specified in PBL each time it starts a Burst transfer on the host bus. The permissible values are 1, 4, 8, 16, 32, 64, 128 and 256. This value is the mirror of MSIZE of FIFOTH register. In order to change this value, write the required value to FIFOTH register. This is an encode value as follows. Transfer unit is 32 bit. PBL is a read-only value.	0
		0x0	1 transfer	
		0x1	4 transfers	
		0x2	8 transfers	
		0x3	16 transfers	
		0x4	32 transfers	
		0x5	64 transfers	
		0x6	128 transfers	
		0x7	256 transfers	
31:11	-		Reserved	

20.6.28 Poll Demand Register (PLDMND)

Table 306. Poll Demand Register (PLDMND, address 0x4000 4084) bit description

Bit	Symbol	Description	Reset value
31:0	PD	Poll Demand. If the OWN bit of a descriptor is not set, the FSM goes to the Suspend state. The host needs to write any value into this register for the SD/MMC DMA state machine to resume normal descriptor fetch operation. This is a write only register. PD bit is write-only.	

20.6.29 Descriptor List Base Address Register (DBADDR)

Table 307. Descriptor List Base Address Register (DBADDR, address 0x4000 4088) bit description

Bit	Symbol	Description	Reset value
31:0	SDL	Start of Descriptor List. Contains the base address of the First Descriptor. The LSB bits [1:0] are ignored and taken as all-zero by the SD/MMC DMA internally. Hence these LSB bits are read-only.	0

20.6.30 Internal DMAC Status Register (IDSTS)

Table 308. Internal DMAC Status Register (IDSTS, address 0x4000 408C) bit description

Bit	Symbol	Description	Reset value
0	TI	Transmit Interrupt. Indicates that data transmission is finished for a descriptor. Writing a 1 clears this bit.	0
1	RI	Receive Interrupt. Indicates the completion of data reception for a descriptor. Writing a 1 clears this bit.	0
2	FBE	Fatal Bus Error Interrupt. Indicates that a Bus Error occurred (IDSTS[12:10]). When this bit is set, the DMA disables all its bus accesses. Writing a 1 clears this bit.	0
3	-	Reserved	
4	DU	Descriptor Unavailable Interrupt. This bit is set when the descriptor is unavailable due to OWN bit = 0 (DES0[31] = 0). Writing a 1 clears this bit.	0
5	CES	Card Error Summary. Indicates the status of the transaction to/from the card; also present in RINTSTS. Indicates the logical OR of the following bits: EBE - End Bit Error RTO - Response Time-out/Boot Ack Time-out RCRC - Response CRC SBE - Start Bit Error DRTO - Data Read Time-out/BDS time-out DCRC - Data CRC for Receive RE - Response Error Writing a 1 clears this bit.	0
7:6	-	Reserved	
8	NIS	Normal Interrupt Summary. Logical OR of the following: IDSTS[0] - Transmit Interrupt IDSTS[1] - Receive Interrupt Only unmasked bits affect this bit. This is a sticky bit and must be cleared each time a corresponding bit that causes NIS to be set is cleared. Writing a 1 clears this bit.	0
9	AIS	Abnormal Interrupt Summary. Logical OR of the following: IDSTS[2] - Fatal Bus Interrupt IDSTS[4] - DU bit Interrupt IDSTS[5] - Card Error Summary Interrupt Only unmasked bits affect this bit. This is a sticky bit and must be cleared each time a corresponding bit that causes AIS to be set is cleared. Writing a 1 clears this bit.	0

Table 308. Internal DMAC Status Register (IDSTS, address 0x4000 408C) bit description

Bit	Symbol	Description	Reset value
12:10	EB	Error Bits. Indicates the type of error that caused a Bus Error. Valid only with Fatal Bus Error bit (IDSTS[2]) set. This field does not generate an interrupt. 001 - Host Abort received during transmission 010 - Host Abort received during reception Others: Reserved EB is read-only.	0
16:13	FSM	DMAC state machine present state. 0 - DMA_IDLE 1 - DMA_SUSPEND 2 - DESC_RD 3 - DESC_CHK 4 - DMA_RD_REQ_WAIT 5 - DMA_WR_REQ_WAIT 6 - DMA_RD 7 - DMA_WR 8 - DESC_CLOSE This bit is read-only.	0
31:17	-	Reserved	

20.6.31 Internal DMAC Interrupt Enable Register (IDINTEN)

Table 309. Internal DMAC Interrupt Enable Register (IDINTEN, address 0x4000 4090) bit description

Bit	Symbol	Description	Reset value
0	TI	Transmit Interrupt Enable. When set with Normal Interrupt Summary Enable, Transmit Interrupt is enabled. When reset, Transmit Interrupt is disabled.	0
1	RI	Receive Interrupt Enable. When set with Normal Interrupt Summary Enable, Receive Interrupt is enabled. When reset, Receive Interrupt is disabled.	0
2	FBE	Fatal Bus Error Enable. When set with Abnormal Interrupt Summary Enable, the Fatal Bus Error Interrupt is enabled. When reset, Fatal Bus Error Enable Interrupt is disabled.	0
3	-	Reserved	
4	DU	Descriptor Unavailable Interrupt. When set along with Abnormal Interrupt Summary Enable, the DU interrupt is enabled.	0
5	CES	Card Error summary Interrupt Enable. When set, it enables the Card Interrupt summary.	0
7:6	-	Reserved	

Table 309. Internal DMAC Interrupt Enable Register (IDINTEN, address 0x4000 4090) bit description

Bit	Symbol	Description	Reset value
8	NIS	Normal Interrupt Summary Enable. When set, a normal interrupt is enabled. When reset, a normal interrupt is disabled. This bit enables the following bits: IDINTEN[0] - Transmit Interrupt IDINTEN[1] - Receive Interrupt	0
9	AIS	Abnormal Interrupt Summary Enable. When set, an abnormal interrupt is enabled. This bit enables the following bits: IDINTEN[2] - Fatal Bus Error Interrupt IDINTEN[4] - DU Interrupt IDINTEN[5] - Card Error Summary Interrupt	0
31:10	-	Reserved	

20.6.32 Current Host Descriptor Address Register (DSCADDR)

Table 310. Current Host Descriptor Address Register (DSCADDR, address 0x4000 4094) bit description

Bit	Symbol	Description	Reset value
31:0	HDA	Host Descriptor Address Pointer. Cleared on reset. Pointer updated by IDMAC during operation. This register points to the start address of the current descriptor read by the SD/MMC DMA.	0

20.6.33 Current Buffer Descriptor Address Register (BUFADDR)

Table 311. Current Buffer Descriptor Address Register (BUFADDR, address 0x4000 4098) bit description

Bit	Symbol	Description	Reset value
31:0	HBA	Host Buffer Address Pointer. Cleared on Reset. Pointer updated by IDMAC during operation. This register points to the current Data Buffer Address being accessed by the SD/MMC DMA.	0

20.7 Functional description

20.7.1 Power/pull-up control and card detection unit

Signal pull-up resistors can be enabled for the SD pins via the SCU by enabling the pull-up for the pads. The approximate pull-up value for a pin is about 50 kOhm. For designs that need to support legacy MMC cards in open-drain mode, an external pull-up controlled with a general purpose output and FET will be needed for the CMD line.

Slot power can be controlled with the SD_POW pin and the SD_VOLT[2:0] pins. It is recommended that the slot power regulator is enabled and disabled via the SD_POW pin, which can be directly controlled with bit 0 of the Power enable register (PWREN).

Use of the SD_VOLT[2:0] pins is optional and not needed in a design with a single power supply sourcing the card slot.

The card detection signal is debounced based on the number of blocks specified in the Debounce Count Register (DEBNCE). When this signal is connected to the card detect pin of the card slot, then CDETECT register's bit 0 state will be filtered by the number of debounce cycles specified in DEBNCE. This guarantees that interrupt related to the card detect signal are debounced before occurring.

20.7.2 Auto-Stop

The auto-stop command helps to send an exact number of data bytes using a stream read or write for the MMC, and a multiple-block read or write for SD memory transfer for SD cards. The module internally generates a stop command and is loaded in the command path when the SEND_AUTO_STOP bit is set in the Command register.

The software should set the SEND_AUTO_STOP bit according to details listed in table below:

Table 312. SEND_AUTO_STOP bit

Card Type	Transfer Type	Byte Count	SEND_AUTO_STOP bit set	Comments
MMC	Stream read	0	No	Open-ended stream
MMC	Stream read	>0	Yes	Auto-stop after all bytes transfer
MMC	Stream read	0	No	Open-ended stream
MMC	Stream read	>0	Yes	Auto-stop after all bytes transfer
MMC	Single-block read	>0	No	Byte count = 0 is illegal
MMC	Single-block write	>0	No	Byte count = 0 is illegal
MMC	Multiple-block read	0	No	Open-ended multiple block
MMC	Multiple-block read	>0	Yes ^[1]	Pre-defined multiple block
MMC	Multiple-block write	0	No	Open-ended multiple block
MMC	Multiple-block write	>0	Yes ^[1]	Pre-defined multiple block
SDMEM	Single-block read	>0	No	Byte count = 0 is illegal
SDMEM	Single-block write	>0	No	Byte count = 0 is illegal
SDMEM	Multiple-block read	0	No	Open-ended multiple block
SDMEM	Multiple-block read	>0	Yes	Auto-stop after all bytes transfer
SDMEM	Multiple-block write	0	No	Open-ended multiple block
SDMEM	Multiple-block write	>0	Yes	Auto-stop after all bytes transfer
SDIO	Single-block read	>0	No	Byte count = 0 is illegal
SDIO	Single-block write	>0	No	Byte count = 0 is illegal
SDIO	Multiple-block read	0	No	Open-ended multiple block
SDIO	Multiple-block read	>0	No	Pre-defined multiple block
SDIO	Multiple-block write	0	No	Open-ended multiple block
SDIO	Multiple-block write	>0	No	Pre-defined multiple block

- [1] The condition under which the transfer mode is set to block transfer and `byte_count` is equal to block size is treated as a single-block data transfer command for both MMC and SD cards. If `byte_count = n × block_size` ($n = 2, 3, \dots$), the condition is treated as a predefined multiple-block data transfer command. In the case of an MMC card, the cpu software can perform a predefined data transfer in two ways: 1) Issue the CMD23 command before issuing CMD18/CMD25 commands to the card – in this case, issue CMD18/CMD25 commands without setting the `send_auto_stop` bit. 2) Issue CMD18/CMD25 commands without issuing CMD23 command to the card, with the `send_auto_stop` bit set. In this case, the multiple-block data transfer is terminated by an internally-generated auto-stop command after the programmed byte count.

The following list conditions for the auto-stop command.

- Stream read for MMC card with byte count greater than 0 - The Module generates an internal stop command and loads it into the command path so that the end bit of the stop command is sent out when the last byte of data is read from the card and no extra data byte is received. If the byte count is less than 6 (48 bits), a few extra data bytes are received from the card before the end bit of the stop command is sent.
- Stream write for MMC card with byte count greater than 0 - The Module generates an internal stop command and loads it into the command path so that the end bit of the stop command is sent when the last byte of data is transmitted on the card bus and no extra data byte is transmitted. If the byte count is less than 6 (48 bits), the data path transmits the data last in order to meet the above condition.
- Multiple-block read memory for SD card with byte count greater than 0 - If the block size is less than 4 (single-bit data bus), 16 (4-bit data bus), or 32 (8-bit data bus), the auto-stop command is loaded in the command path after all the bytes are read. Otherwise, the top command is loaded in the command path so that the end bit of the stop command is sent after the last data block is received.
- Multiple-block write memory for SD card with byte count greater than 0 - If the block size is less than 3 (single-bit data bus), 12 (4-bit data bus), or 24 (8-bit data bus), the auto-stop command is loaded in the command path after all data blocks are transmitted. Otherwise, the stop command is loaded in the command path so that the end bit of the stop command is sent after the end bit of the CRC status is received.
- Precaution for cpu software during auto-stop - Whenever an auto-stop command is issued, the cpu software should not issue a new command to the Module until the auto-stop is sent by the Module and the data transfer is complete. If the cpu issues a new command during a data transfer with the auto-stop in progress, an auto-stop command may be sent after the new command is sent and its response is received; this can delay sending the stop command, which transfers extra data bytes. For a stream write, extra data bytes are erroneous data that can corrupt the card data. If the cpu wants to terminate the data transfer before the data transfer is complete, it can issue a stop or abort command, in which case the Module does not generate an auto-stop command.

20.7.3 Software/hardware restrictions

Only one data transfer command should be issued at one time. For CE-ATA devices, if CE-ATA device interrupts are enabled (`nIEN=0`), only one `RW_MULTIPLE_BLOCK` command (`RW_BLK`) should be issued; no other commands (including a new `RW_BLK`) should be issued before the Data Transfer. `Over` status is set for the outstanding `RW_BLK`.

Before issuing a new data transfer command, the software should ensure that the card is not busy due to any previous data transfer command. Before changing the card clock frequency, the software must ensure that there are no data or command transfers in progress.

To avoid glitches in the card clock outputs (cclk_out), the software should use the following steps when changing the card clock frequency:

1. Update the Clock Enable register to disable all clocks. To ensure completion of any previous command before this update, send a command to the CIU to update the clock registers by setting:
 - start_cmd bit
 - "update clock registers only" bits
 - "wait_previous data complete" bitWait for the CIU to take the command by polling for 0 on the start_cmd bit.
2. Set the start_cmd bit to update the Clock Divider and/or Clock Source registers, and send a command to the CIU in order to update the clock registers; wait for the CIU to take the command.
3. Set start_cmd to update the Clock Enable register in order to enable the required clocks and send a command to the CIU to update the clock registers; wait for the CIU to take the command.

In non-DMA mode, while reading from a card, the Data Transfer Over (RINTSTS[3]) interrupt occurs as soon as the data transfer from the card is over. There still could be some data left in the FIFO, and the RX_WMark interrupt may or may not occur, depending on the remaining bytes in the FIFO. Software should read any remaining bytes upon seeing the Data Transfer Over (DTO) interrupt. In DMA mode while reading from a card, the DTO interrupt occurs only after all the FIFO data is flushed to memory by the DMA Interface unit.

While writing to a card in DMA mode, if an undefined-length transfer is selected by setting the Byte Count register to 0, the DMA logic will likely request more data than it will send to the card, since it has no way of knowing at which point the software will stop the transfer. The DMA request stops as soon as the DTO is set by the CIU.

If the software issues a controller_reset command by setting control register bit[0] to 1, all the CIU state machines are reset; the FIFO is not cleared. The DMA sends all remaining bytes to the cpu. In addition to a card-reset, if a FIFO reset is also issued, then:

- Any pending DMA transfer on the bus completes correctly
- DMA data read is ignored
- Write data is unknown (x)

Additionally, if dma_reset is also issued, any pending DMA transfer is abruptly terminated. The DMA controller channel should also be reset and reprogrammed.

If any of the previous data commands do not properly terminate, then the software should issue the FIFO reset in order to remove any residual data, if any, in the FIFO. After asserting the FIFO reset, you should wait until this bit is cleared.

One data-transfer requirement between the FIFO and cpu is that the number of transfers should be a multiple of the FIFO data width (F_DATA_WIDTH), which is 32. So if you want to write only 15 bytes to an SD/MMC/CE-ATA card (BYTCNT), the cpu should write 16 bytes to the FIFO or program the DMA to do 16-byte transfers, if DMA mode is enabled. The software can still program the Byte Count register to only 15, at which point only 15 bytes will be transferred to the card. Similarly, when 15 bytes are read from a card, the cpu should still read all 16 bytes from the FIFO.

It is recommended that you do not change the FIFO threshold register in the middle of data transfers.

20.7.4 Programming sequence

20.7.4.1 Initialization

Once the power and clocks are stable, reset_n should be asserted (active-low) for at least two clocks of clk or cclk_in, whichever is slower. The reset initializes the registers, ports, FIFO-pointers, DMA interface controls, and state-machines in the design. After power-on reset, the software should do the following:

1. After power on reset, configure the SD/MMC pins using the SFSP registers in the syscon block ([Table 173](#)).
2. Set masks for interrupts by clearing appropriate bits in the Interrupt Mask register @0x024. Set the global int_enable bit of the Control register @0x00. It is recommended that you write 0xffff_ffff to the Raw Interrupt register @0x044 in order to clear any pending interrupts before setting the int_enable bit.
3. Enumerate card stack - Each card is enumerated according to card type; for details, refer to "Enumerated Card Stack". For enumeration, you should restrict the clock frequency to 400 KHz in accordance with SD_MMC/CE-ATA standards.
4. Changing clock. The cards operate at a maximum of 26 MHz (at maximum of 52 MHz in high-speed mode).
5. Set other IP parameters, which normally do not need to be changed with every command, with a typical value such as time-out values in cclk_out according to SD_MMC/CE-ATA specifications.

ResponseTimeOut = 0x40

DataTimeOut = highest of one of the following:

- $(10 \times ((TAAC \times Fop) + (100 \times NSAC)))$
- Cpu FIFO read/write latency from FIFO empty/full

FIFO threshold value in bytes in the FIFOTH register @0x04C. Typically, the threshold value can be set to half the FIFO depth (=32); that is:

- $RX_WMark = (FIFO_DEPTH/2) - 1;$
- $TX_WMark = FIFO_DEPTH/2$

6. If the software decides to handle the interrupts provided by the IP core, you should create another thread to handle interrupts.

20.7.4.2 Enumerated Card Stack

The card stack does the following:

- Enumerates all connected cards
- Sets the RCA for the connected cards
- Reads card-specific information
- Stores card-specific information locally

Enumerate_Card_Stack - Enumerates the card connected on the module. The card can be of the type MMC, CE-ATA, SD, or SDIO. All types of SDIO cards are supported; that is, SDIO_IO_ONLY, SDIO_MEM_ONLY, and SDIO_COMBO cards. The enumeration sequence includes the following steps:

1. Check if the card is connected.
2. Clear the bits in the card_type register. Clear the register bit for a 1-bit, 4-bit, or 8-bit bus width.
3. Identify the card type; that is, SD, MMC, or SDIO.
 - Send CMD5 first. If a response is received, then the card is SDIO
 - If not, send ACMD41; if a response is received, then the card is SD.
 - Otherwise, the card is an MMC or CE-ATA
4. Enumerate the card according to the card type.

Use a clock source with a frequency = Fod (that is, 400 KHz) and use the following enumeration command sequence:

 - SD card - Send CMD0, ACMD41, CMD2, CMD3.
 - SDHC card - send CMD0, SDCMD8, ACMD41, CMD2, CMD3
 - SDIO - Send CMD5; if the function count is valid, CMD3. For the SDIO memory section, follow the same commands as for the SD card.
 - MMC - Send CMD0, CMD1, CMD2, CMD3
5. Identify the MMC/CE-ATA device.
 - Selecting ATA mode for a CE-ATA device.
 - Cpu should query the byte 504 (S_CMD_SET) of EXT_CSD register by sending CMD8. If bit 4 is set to 1, then the device supports ATA mode.
 - If ATA mode is supported, the cpu should select the ATA mode by setting the ATA bit (bit 4) of the EXT_CSD register slice 191(CMD_SET) to activate the ATA command set for use. The cpu selects the command set using the SWITCH (CMD6) command.
 - The current mode selected is shown in byte 191 of the EXT_CSD register.

If the device does not support ATA mode, then the device can be an MMC device or a CE-ATA v1.0 device.

 - Send RW_REG; if a response is received and the response data contains CE-ATA signature, the device is a CE-ATA device.
 - Otherwise the device is an MMC card.
6. You can change the card clock frequency after enumeration.

20.7.4.3 Clock Programming

The clock programming has to be done in the CGU. The cclk_in has to be equal to the cclk_out. Therefore the registers that support this have to be:

- CLKDIV @0x08 = 0x0 (bypass of clock divider).
- CLKSRC @0x0C = 0x0
- CLKENA @0x10 = 0x0 or 0x1. This register enables or disables clock for the card and enables low-power mode, which automatically stops the clock to a card when the card is idle for more than 8 clocks.

The Module loads each of these registers only when the start_cmd bit and the Update_clk_regs_only bit in the CMD register are set. When a command is successfully loaded, the Module clears this bit, unless the Module already has another command in the queue, at which point it gives an HLE (Hardware Locked Error); for details on HLEs, refer to "Error Handling".

Software should look for the start_cmd and the Update_clk_regs_only bits, and should also set the wait_prvdata_complete bit to ensure that clock parameters do not change during data transfer. Note that even though start_cmd is set for updating clock registers, the Module does not raise a command_done signal upon command completion.

20.7.4.4 No-Data Command With or Without Response Sequence

To send any non-data command, the software needs to program the CMD register @0x2C and the CMDARG register @0x28 with appropriate parameters. Using these two registers, the Module forms the command and sends it to the command bus. The Module reflects the errors in the command response through the error bits of the RINTSTS register.

When a response is received - either erroneous or valid - the Module sets the command_done bit in the RINTSTS register. A short response is copied in Response Register0, while a long response is copied to all four response registers @0x30, 0x34, 0x38, and 0x3C. The Response3 register bit 31 represents the MSB, and the Response0 register bit 0 represents the LSB of a long response.

For basic commands or non-data commands, follow these steps:

1. Program the Command register @0x28 with the appropriate command argument parameter.
2. Program the Command register @0x2C with the settings in [Table 313](#).
3. Wait for command acceptance by cpu. The following happens when the command is loaded into the Module:
 - Module accepts the command for execution and clears the start_cmd bit in the CMD register, unless one command is in process, at which point the Module can load and keep the second command in the buffer.
 - If the Module is unable to load the command - that is, a command is already in progress, a second command is in the buffer, and a third command is attempted - then it generates an HLE (hardware-locked error).
 - Check if there is an HLE.
 - Wait for command execution to complete. After receiving either a response from a card or response time-out, the Module sets the command_done bit in the RINTSTS register. Software can either poll for this bit or respond to a generated interrupt.

- Check if response_timeout error, response_CRC error, or response error is set. This can be done either by responding to an interrupt raised by these errors or by polling bits 1, 6, and 8 from the RINTSTS register @0x44. If no response error is received, then the response is valid. If required, the software can copy the response from the response registers @0x30-0x3C.

Software should not modify clock parameters while a command is being executed.

Table 313. CMD register settings for No-Data Command

Name	Value	Comment
start_cmd	1	
update_clock_registers_only	0	No clock parameters update command
card_number	0	Card number in use. Only zero is possible because one card is support.
Data_expected	0	No data command.
Send_initialization	0	Can be 1, but only for card reset commands, such as CMD0
stop_abort_cmd	0	Can be 1 for commands to stop data transfer, such as CMD12
Cmd_index	Command index	
Response_length	0	Can be 1 for R2 (long) response
Response_expect	1	Can be 0 for commands with no response; for example, CMD0, CMD4, CMD15, and so on
User-selectable		
Wait_prvdata_complete	1	Before sending command on command line, cpu should wait for completion of any data command in process, if any (recommended to always set this bit, unless the current command is to query status or stop data transfer when transfer is in progress)
Check_response_crc	1	0 – Do not check response CRC 1 – Check response CRC Some of command responses do not return valid CRC bits. Software should disable CRC checks for those commands in order to disable CRC checking by controller.

20.7.4.5 Data Transfer Commands

Data transfer commands transfer data between the memory card and the Module. To send a data command, the Module needs a command argument, total data size, and block size. Software can receive or send data through the FIFO.

Before a data transfer command, software should confirm that the card is not busy and is in a transfer state, which can be done using the CMD13 and CMD7 commands, respectively.

For the data transfer commands, it is important that the same bus width that is programmed in the card should be set in the card type register @0x18. Therefore, in order to change the bus width, you should always use the following supplied APIs as appropriate for the type of card:

- Set_SD_Mode() - SD/SDIO card
- Set_HSmodeSettings() - HSMMC card

The Module generates an interrupt for different conditions during data transfer, which are reflected in the RINTSTS register @0x44 as:

1. Data_Transfer_Over (bit 3) - When data transfer is over or terminated. If there is a response time-out error, then the Module does not attempt any data transfer and the "Data Transfer Over" bit is never set.
2. Transmit_FIFO_Data_request (bit 4) - FIFO threshold for transmitting data was reached; software is expected to write data, if available, in FIFO.
3. Receive_FIFO_Data_request (bit 5) - FIFO threshold for receiving data was reached; software is expected to read data from FIFO.
4. Data starvation by Cpu time-out (bit 10) - FIFO is empty during transmission or is full during reception. Unless software writes data for empty condition or reads data for full condition, the Module cannot continue with data transfer. The clock to the card has been stopped.
5. Data read time-out error (bit 9) - Card has not sent data within the time-out period.
6. Data CRC error (bit 7) - CRC error occurred during data reception.
7. Start bit error (bit 13) - Start bit was not received during data reception.
8. End bit error (bit 15) - End bit was not received during data reception or for a write operation; a CRC error is indicated by the card.

Conditions 6, 7, and 8 indicate that the received data may have errors. If there was a response time-out, then no data transfer occurred.

20.7.4.6 Single-Block or Multiple-Block Read

Steps involved in a single-block or multiple-block read are:

1. Write the data size in bytes in the BYTCNT register @0x20.
2. Write the block size in bytes in the BLKSIZ register @0x1C. The Module expects data from the card in blocks of size BLKSIZ each.
3. Program the CMDARG register @0x28 with the data address of the beginning of a data read. Program the Command register with the parameters listed in [Table 314](#). For SD and MMC cards, use CMD17 for a single-block read and CMD18 for a multiple-block read. For SDIO cards, use CMD53 for both single-block and multiple-block transfers.

After writing to the CMD register, the Module starts executing the command; when the command is sent to the bus, the command_done interrupt is generated.

4. Software should look for data error interrupts; that is, bits 7, 9, 13, and 15 of the RINTSTS register. If required, software can terminate the data transfer by sending a STOP command.

5. Software should look for Receive_FIFO_Data_request and/or data starvation by cpu time-out conditions. In both cases, the software should read data from the FIFO and make space in the FIFO for receiving more data.
6. When a Data_Transfer_Over interrupt is received, the software should read the remaining data from the FIFO.

Table 314. CMD register settings for Single-block or Multiple-block Read

Name	Value	Comment
start_cmd	1	
update_clock_registers_only	0	No clock parameters update command
card_number	0	Card number in use. Only zero is possible because one card is support.
Data_expected	1	
Send_initialization	0	Can be 1, but only for card reset commands, such as CMD0
stop_abort_cmd	0	Can be 1 for commands to stop data transfer, such as CMD12
Send_auto_stop	0/1	
Transfer_mode	0	Block transfer
Read_write	0	Read from card
Cmd_index	Command index	
Response_length	0	Can be 1 for R2 (long) response
Response_expect	1	Can be 0 for commands with no response; for example, CMD0, CMD4, CMD15, and so on
User-selectable		
Wait_prvdata_complete	1	Before sending command on command line, cpu should wait for completion of any data command in process, if any (recommended to always set this bit, unless the current command is to query status or stop data transfer when transfer is in progress)
Check_response_crc	1	0 – Do not check response CRC 1 – Check response CRC Some of command responses do not return valid CRC bits. Software should disable CRC checks for those commands in order to disable CRC checking by controller.

20.7.4.7 Single-Block or Multiple-Block Write

Steps involved in a single-block or multiple-block write are:

1. Write the data size in bytes in the BYTCNT register @0x20.
2. Write the block size in bytes in the BLKSIZ register @0x1C; the Module sends data in blocks of size BLKSIZ each.

3. Program CMDARG register @0x28 with the data address to which data should be written.
4. Write data in the FIFO; it is usually best to start filling data the full depth of the FIFO.
5. Program the Command register with the parameters listed in [Table 315](#). For SD and MMC cards, use CMD24 for a single-block write and CMD25 for a multiple-block write. For SDIO cards, use CMD53 for both single-block and multiple-block transfers.
After writing to the CMD register, Module starts executing a command; when the command is sent to the bus, a command_done interrupt is generated.
6. Software should look for data error interrupts; that is, for bits 7, 9, and 15 of the RINTSTS register. If required, software can terminate the data transfer by sending the STOP command.
7. Software should look for Transmit_FIFO_Data_request and/or time-out conditions from data starvation by the cpu. In both cases, the software should write data into the FIFO.
8. When a Data_Transfer_Over interrupt is received, the data command is over. For an open-ended block transfer, if the byte count is 0, the software must send the STOP command. If the byte count is not 0, then upon completion of a transfer of a given number of bytes, the Module should send the STOP command, if necessary. Completion of the AUTO-STOP command is reflected by the Auto_command_done interrupt - bit 14 of the RINTSTS register. A response to AUTO_STOP is stored in RESP1 @0x34.

Table 315. CMD register settings for Single-block or Multiple-block write

Name	Value	Comments
start_cmd	1	
update_clock_registers_only	0	No clock parameters update command
card_number	0	Card number in use. Only zero is possible because one card is support.
Data_expected	1	
Send_initialization	0	Can be 1, but only for card reset commands, such as CMD0
stop_abort_cmd	0	Can be 1 for commands to stop data transfer, such as CMD12
Send_auto_stop	0/1	
Transfer_mode	0	Block transfer
Read_write	1	Write to card
Cmd_index	Command index	
Response_length	0	Can be 1 for R2 (long) response
Response_expect	1	Can be 0 for commands with no response; for example, CMD0, CMD4, CMD15, and so on

Table 315. CMD register settings for Single-block or Multiple-block write

Name	Value	Comments
User-selectable		
Wait_prvdata_complete	1	Before sending command on command line, cpu should wait for completion of any data command in process, if any (recommended to always set this bit, unless the current command is to query status or stop data transfer when transfer is in progress)
Check_response_crc	1	0 – Do not check response CRC 1 – Check response CRC Some of command responses do not return valid CRC bits. Software should disable CRC checks for those commands in order to disable CRC checking by controller.

20.7.4.8 Stream Read

A stream read is like the block read mentioned in "Single-Block or Multiple-Block Read", except for the following bits in the Command register:

```
transfer_mode = 1; //Stream transfer
```

```
cmd_index = CMD20;
```

A stream transfer is allowed for only a single-bit bus width.

20.7.4.9 Stream Write

A stream write is exactly like the block write mentioned in "Single-Block or Multiple-Block Write", except for the following bits in the Command register:

- transfer_mode = 1; //Stream transfer
- cmd_index = CMD11;

In a stream transfer, if the byte count is 0, then the software must send the STOP command. If the byte count is not 0, then when a given number of bytes completes a transfer, the Module sends the STOP command. Completion of this AUTO_STOP command is reflected by the Auto_command_done interrupt. A response to an AUTO_STOP is stored in the RESP1 register @0x34.

A stream transfer is allowed for only a single-bit bus width.

20.7.4.10 Sending Stop or Abort in Middle of Transfer

The STOP command can terminate a data transfer between a memory card and the Module, while the ABORT command can terminate an I/O data transfer for only the SDIO_IONLY and SDIO_COMBO cards.

- Send STOP command - Can be sent on the command line while a data transfer is in progress; this command can be sent at any time during a data transfer. For information on sending this command, refer to "No-Data Command With or Without Response Sequence".

You can also use an additional setting for this command in order to set the Command register bits (5-0) to CMD12 and set bit 14 (stop_abort_cmd) to 1. If stop_abort_cmd is not set to 1, the user stopped a data transfer. Reset bit 13 of the Command register (wait_prvdata_complete) to 0 in order to make the Module send the command at once, even though there is a data transfer in progress.

- Send ABORT command - Can be used with only an SDIO_IOONLY or SDIO_COMBO card. To abort the function that is transferring data, program the function number in ASx bits (CCCR register of card, address 0x06, bits (0-2) using CMD52.

This is a non-data command. For information on sending this command, refer to "No-Data Command With or Without Response Sequence".

Program the CMDARG register @0x28 with the appropriate command argument parameters listed in [Table 316](#).

- Program the Command register using the command index as CMD52. Similar to the STOPcommand, set bit 14 of the Command register (stop_abort_cmd) to 1, which must be done in order to inform the Module that the user aborted the data transfer. Reset bit 13 (wait_prvdata_complete) of the Command register to 0 in order to make the Module send the command at once, even though a data transfer is in progress.
- Wait for command_transfer_over.
- Check response (R5) for errors.
- During an open-ended card write operation, if the card clock is stopped because the FIFO is empty, the software must first fill the data into the FIFO and start the card clock before issuing a stop/abort command to the card.

Table 316. Parameters for CMDARG register

Bits	Contents	Value
31	R/W flag	1
30-28	Function number	0, for CCCR access
27	RAW flag	1, if needed to read after write
26	Don't care	-
25-9	Register address	0x06
8	Don't care	-
7-0	Write data	Function number to be aborted

20.7.5 Suspend or Resume Sequence

In an SDIO card, the data transfer between an I/O function and the Module can be temporarily halted using the SUSPEND command; this may be required in order to perform a high-priority data transfer with another function. When desired, the data transfer can be resumed using the RESUME command.

The following functions can be implemented by programming the appropriate bits in the CCCR register (Function 0) of the SDIO card. To read from or write to the CCCR register, use the CMD52 command.

1. SUSPEND data transfer - Non-data command.

- Check if the SDIO card supports the SUSPEND/RESUME protocol; this can be done through the SBS bit in the CCCR register @0x08 of the card.

Check if the data transfer for the required function number is in process; the function number that is currently active is reflected in bits 0-3 of the CCCR register @0x0D. Note that if the BS bit (address 0xc:bit 0) is 1, then only the function number given by the FSx bits is valid.

To suspend the transfer, set BR (bit 2) of the CCCR register @0x0C.

Poll for clear status of bits BR (bit 1) and BS (bit 0) of the CCCR @0x0C. The BS (Bus Status) bit is 1 when the currently-selected function is using the data bus; the BR (Bus Release) bit remains 1 until the bus release is complete. When the BR and BS bits are 0, the data transfer from the selected function has been suspended.

During a read-data transfer, the Module can be waiting for the data from the card. If the data transfer is a read from a card, then the Module must be informed after the successful completion of the SUSPEND command. The Module then resets the data state machine and comes out of the wait state. To accomplish this, set `abort_read_data` (bit 8) in the Control register.

Wait for data completion. Get pending bytes to transfer by reading the TCBCNT register @0x5C.

2. RESUME data transfer - This is a data command.

- Check that the card is not in a transfer state, which confirms that the bus is free for data transfer.

If the card is in a disconnect state, select it using CMD7. The card status can be retrieved in response to CMD52/CMD53 commands.

Check that a function to be resumed is ready for data transfer; this can be confirmed by reading the RFx flag in CCCR @0x0F. If RF = 1, then the function is ready for data transfer.

To resume transfer, use CMD52 to write the function number at FSx bits (0-3) in the CCCR register @0x0D. Form the command argument for CMD52 and write it in CMDARG @0x28; bit values are listed in [Table 317](#).

- Write the block size in the BLKSIZ register @0x1C; data will be transferred in units of this block size.

Write the byte count in the BYTCNT register @0x20. This is the total size of the data; that is, the remaining bytes to be transferred. It is the responsibility of the software to handle the data.

Program Command register; similar to a block transfer. For details, refer to "Single-Block or Multiple-Block Read" and "Single-Block or Multiple-Block Write".

When the Command register is programmed, the command is sent and the function resumes data transfer. Read the DF flag (Resume Data Flag). If it is 1, then the function has data for the transfer and will begin a data transfer as soon as the function or memory is resumed. If it is 0, then the function has no data for the transfer.

If the DF flag is 0, then in case of a read, the Module waits for data. After the data time-out period, it gives a data time-out error.

Table 317. Parameters for CMDARG register

Bits	Contents	Value
31	R/W flag	1
30-28	Function number	0, for CCCR access
27	RAW flag	1, read after write
26	Don't care	-
25-9	Register address	0x0D
8	Don't care	-
7-0	Write data	Function number to be aborted

20.7.5.1 Read_Wait Sequence

Read_wait is used with only the SDIO card and can temporarily stall the data transfer-either from function or memory-and allow the cpu to send commands to any function within the SDIO device. The cpu can stall this transfer for as long as required. The Module provides the facility to signal this stall transfer to the card. The steps for doing this are:

1. Check if the card supports the read_wait facility; read SRW (bit 2) of the CCCR register @0x08. If this bit is 1, then all functions in the card support the read_wait facility. Use CMD52 to read this bit.
2. If the card supports the read_wait signal, then assert it by setting the read_wait (bit 6) in the CTRL register @0x00.
3. Clear the read_wait bit in the CTRL register.

20.7.5.2 CE-ATA Data Transfer Commands

This section describes the CE-ATA data transfer commands. For information on the basic settings and interrupts generated for different conditions, refer to "Data Transfer Commands".

20.7.5.2.1 Reset and Device Recovery

Before starting CE-ATA operations, the cpu should perform an MMC reset and initialization procedure. The cpu and device should negotiate the MMC TRAN state (defined by the MultiMedia Card System Specification) before the device enters the MMC TRAN state. The cpu should follow the existing MMC Card enumeration procedure in order to negotiate the MMC

TRAN state. After completing normal MMC reset and initialization procedures, the cpu should query the initial ATA Task File values using RW_REG/CMD39.

By default, the MMC block size is 512 bytes-indicated by bits 1:0 of the srcControl register inside the CE-ATA device. The cpu can negotiate the use of a 1KB or 4KB MMC block size. The device indicates MMC block sizes that it can support through the srcCapabilities register; the cpu reads this register in order to negotiate the MMC block size. Negotiation is complete when the cpu controller writes the MMC block size into the srcControl register bits 1:0 of the device.

20.7.5.2.2 ATA Task File Transfer

ATA task file registers are mapped to addresses 0x00h-0x10h in the MMC register space. RW_REG is used to issue the ATA command, and the ATA task file is transmitted in a single RW_REG MMC command sequence.

The cpu software stack should write the task file image to the FIFO before setting the CMDARG and CMD registers. The cpu processor then sets the address and byte count in the CMDARG-offset 0x28 in the BIU register space-before setting the CMD (offset 0x2C) register bits.

For RW_REG, there is no command completion signal from the CE-ATA device

ATA Task File Transfer Using RW_MULTIPLE_REGISTER (RW_REG)

This command involves data transfer between the CE-ATA device and the Module. To send a data command, the Module needs a command argument, total data size, and block size. Software can receive or send data through the FIFO.

Steps involved in an ATA Task file transfer (read or write) are:

1. Write the data size in bytes in the BYTCNT register @0x20.
2. Write the block size in bytes in the BLKSIZ register @0x1C; the Module expects a single block transfer.
3. Program the CMDARG register @0x28 with the beginning register address.

You should program the CMDARG, CMD, BLKSIZ, and BYTCNT registers according to the following tables.

- Program the Command Argument (CMDARG) register as shown below.

Table 318. Parameters for CMDARG register

Bits	Contents	Value
31	R/W flag	1 (write) or 0 (read)
30-24	Reserved	0
23:18	Starting register address for read/write; Dword aligned	0
17:16	Register address; Dword aligned	0
15-8	Reserved; bits cleared to 0 by CPU	0
7:2	Number of bytes to read/write; integral number of Dwords	16
1:0	Byte count in integral number of Dwords	0

- Program the Command (CMD) register as shown below.

Table 319. CMD register settings

Name	Value	Comment
start_cmd	1	
Css_expect	0	Command Completion Signal is not expected
Read_ceata_device	0/1	1 – If RW_BLK or RW_REG read
update_clock_registers_only	0	No clock parameters update command
card_number	0	Card number in use. Only zero is possible because one card is support.
Data_expected	1	
Send_initialization	0	Can be 1, but only for card reset commands, such as CMD0
stop_abort_cmd	0	
Send_auto_stop	0	
Transfer_mode	0	Block transfer
Read_write	0/1	0 read from card, 1 - Write to card
Cmd_index	Command index	
Response_length	0	
Response_expect	1	
User-selectable		
Wait_prvdata_complete	1	0 – Sends command immediately 1 – Sends command after previous data transfer over
Check_response_crc	1	0 – Do not check response CRC 1 – Check response CRC

- Program the block size (BLKSIZ) register as shown below.

Table 320. BLKSIZ register

Bits	Value	Comment
31:16	0	Reserved bits as zeroes (0)
15:0	16	For accessing entire task file (16, 8-bit registers); block size of 16 bytes

- Program the Byte Count (BYTCNT) register as shown below.

Table 321. BYTCNT register

Bits	Value	Comment
31:0	16	For accessing entire task file(16, 8 bit registers); byte count value of 16 is used with the block size set to 16

20.7.5.2.3 ATA Payload Transfer Using RW_MULTIPLE_BLOCK (RW_BLK)

This command involves data transfer between the CE-ATA device and the Module. To send a data command, the Module needs a command argument, total data size, and block size. Software can receive or send data through the FIFO.

Steps involved in an ATA payload transfer (read or write) are:

1. Write the data size in bytes in the BYTCNT register @0x20.
2. Write the block size in bytes in the BLKSIZ register @0x1C. The Module expects a single/multiple block transfer.
3. Program the CMDARG register @0x28 to indicate the Data Unit Count.
You should program the CMDARG, CMD, BLKSIZ, and BYTCNT registers according to the following tables.
 - Program the Command Argument (CMDARG) register as shown below.

Table 322. Parameters for CMDARG register

Bits	Contents	Value
31	R/W flag	1 (write) or 0 (read)
30-24	Reserved	0
23:16	Reserved	0
15:8	Data Count Unit [15:8]	Data count
1:0	Data Count Unit [7:0]	Data count

- Program the Command (CMD) register as shown below.

Table 323. CMD register settings

Name	Value	Comment
start_cmd	1	-
Css_expect	1	Command Completion Signal is expected; set for RW_BLK if interrupts are enabled in CE-ATA device, nIEN = 0
Read_ceata_device	0/1	1 – If RW_BLK or RW_REG read
update_clock_registers_only	0	No clock parameters update command
card_number	0	Card number in use. Only zero is possible because one card is support.
Data_expected	1	
Send_initialization	0	Can be 1, but only for card reset commands, such as CMD0
stop_abort_cmd	0	
Send_auto_stop	0	
Transfer_mode	0	Block transfer
Read_write	0/1	0 read from card, 1 - Write to card
Cmd_index	Command index	
Response_length	0	
Response_expect	1	
User-selectable		
Wait_prvdata_complete	1	0 – Sends command immediately 1 – Sends command after previous data transfer over
Check_response_crc	1	0 – Do not check response CRC 1 – Check response CRC

- Program the block size (BLKSIZ) register as shown below.

Table 324. BLKSIZ register

Bits	Value	Comment
31:16	0	Reserved bits as zeroes (0)
15:0	512, 1024, 4096	MMC block size can be 512, 1024, or 4096 bytes as negotiated by CPU

- Program the Byte Count (BYTCNT) register as shown below.

Table 325. BYTCNT register

Bits	Value	Comment
31:0	$N \times \text{block_size}$	byte_count should be integral multiple of block size; for ATA media access commands, byte count should be multiple of 4KB. ($N \times \text{block_size} = X \times 4\text{KB}$, where N and X are integers)

20.7.5.2.4 Sending Command Completion Signal Disable

While waiting for the Command Completion Signal (CCS) for an outstanding RW_BLK, the cpu can send a Command Completion Signal Disable (CCSD).

- Send CCSD - Module sends CCSD to the CE-ATA device if the send_ccsd bit is set in the CTRL register; this bit is set only after a response is received for the RW_BLK.
- Send internal Stop command - Send internally generated STOP (CMD12) command after sending the CCSD pattern. If send_auto_stop_ccsd bit is also set when the controller is programmed to send the CCSD pattern, the Module sends the internally generated STOP command on the CMD line. After sending the STOP command, the Module sets the Auto Command Done bit in the RINTSTS register.

20.7.5.2.5 Recovery after Command Completion Signal Time-out

If time-out happened while waiting for Command Completion Signal (CCS), the cpu needs to send Command Completion Signal Disable (CCSD) followed by a STOP command to abort the pending ATA command. The cpu can program the Module to send internally generated STOP command after sending the CCSD pattern

- Send CCSD - Set the send_ccsd bit in the CTRL register.
- Reset bit 13 of the Command register (wait_prvdata_complete) to 0 in order to make the Module send the command at once, even though there is a data transfer in progress.
- Send internal STOP command - Set send_auto_stop_ccsd bit in the CTRL register, which programs the cpu controller to send the internally generated STOP command. After sending the STOP command, the Module sets the Auto Command Done bit in the RINTSTS register.

20.7.5.2.6 Reduced ATA Command Set

It is necessary for the CE-ATA device to support the reduced ATA command subset. The following details discuss this reduced command set.

- IDENTIFY DEVICE - Returns 512-byte data structure to the cpu that describes device-specific information and capabilities. The cpu issues the IDENTIFY DEVICE command only if the MMC block size is set to 512 bytes; any other MMC block size has indeterminate results.

The cpu issues RW_REG for the ATA command, and the data is retrieved through RW_BLK.

The cpu controller uses the following settings while sending RW_REG for the IDENTIFY DEVICE ATA command. The following lists the primary bit

- CMD register setting - data_expected field set to 0
- CMDARG register settings:
 - Bit [31] set to 0
 - Bits [7:2] set to 128.
- Task file settings:
 - Command field of the ATA task file set to ECh
 - Reserved fields of the task file cleared to 0

- BLKSIZ register bits [15:0] and BYTCNT register - Set to 16

The cpu controller uses the following settings for data retrieval (RW_BLK):\

- CMD register settings:
 - ccs_expect set to 1
 - data_expected set to 1
- CMDARG register settings:
 - Bit [31] set to 0 (Read operation)
 - Data Count set to 1 (16'h0001)
- BLKSIZ register bits [15:0] and BYTCNT register - Set to 512 IDENTIFY DEVICE can be aborted as a result of the CPU issued CMD12.
 - READ DMA EXT - Reads a number of logical blocks of data from the device using the Data-In data transfer protocol. The cpu uses RW_REG to issue the ATA command and RW_BLK for the data transfer.
 - WRITE DMA EXT - Writes a number of logical blocks of data to the device using the Data-Out data transfer protocol. The cpu uses RW_REG to issue the ATA command and RW_BLK for the data transfer.
 - STANDBY IMMEDIATE - No data transfer (RW_BLK) is expected for this ATA command, which causes the device to immediately enter the most aggressive power management mode that still retains internal device context.
- CMD Register setting - data_expected field set to 0
- CMDARG register settings:
 - Bit [31] set to 1
 - Bits [7:2] set to 4
- Task file settings:

- Command field of the ATA task file set to E0h
- Reserved fields of the task file cleared to 0
- BLKSIZ register bits [15:0] and BYTCNT register - Set to 16
 - FLUSH CACHE EXT - No data transfer (RW_BLK) is expected for this ATA command. For devices that buffer/cache written data, the FLUSH CACHE EXT command ensures that buffered data is written to the device media. For devices that do not buffer written data, FLUSH CACHE EXT returns a success status. The cpu issues RW_REG for the ATA command, and the status is retrieved through CMD39/RW_REG; there can be error status for this ATA command, in which case fields other than the status field of the ATA task file are valid.
- The CPU uses the following settings while sending the RW_REG for STANDBY IMMEDIATE ATA command:
 - CMD register setting - data_expected field set to 0
 - CMDARG register settings:
 - Bit [31] set to 1
 - Bits [7:2] set to 4
 - Task file settings:
 - Command field of the ATA task file set to EAh
 - Reserved fields of the task file cleared to 0
 - BLKSIZ register bits [15:0] and BYTCNT register - Set to 16

20.7.5.3 Controller/DMA/FIFO Reset Usage

Communication with the card involves the following:

- Controller - Controls all functions of the Module.
- FIFO - Holds data to be sent or received.
- DMA - If DMA transfer mode is enabled, then transfers data between system memory and the FIFO.
- Controller reset - Resets the controller by setting the controller_reset bit (bit 0) in the CTRL register; this resets the CIU and state machines, and also resets the BIU-to-CIU interface. Since this reset bit is self-clearing, after issuing the reset, wait until this bit is cleared.
- FIFO reset - Resets the FIFO by setting the fifo_reset bit (bit 1) in the CTRL register; this resets the FIFO pointers and counters of the FIFO. Since this reset bit is self-clearing, after issuing the reset, wait until this bit is cleared.
 - DMA reset - Resets the internal DMA controller logic by setting the dma_reset bit (bit 2) in the CTRL register, which abruptly terminates any DMA transfer in process. Since this reset bit is self-clearing, after issuing the reset, wait until this bit is cleared.

The following are recommended methods for issuing reset commands:

- Non-DMA transfer mode - Simultaneously sets controller_reset and fifo_reset; clears the RAWINTS register @0x44 using another write in order to clear any resultant interrupt.

- Generic DMA mode - Simultaneously sets `controller_reset`, `fifo_reset`, and `dma_reset`; clears the RAWINTS register @0x44 by using another write in order to clear any resultant interrupt. If a "graceful" completion of the DMA is required, then it is recommended to poll the status register to see whether the `dma_request` is 0 before resetting the DMA interface control and issuing an additional FIFO reset.
- In DMA transfer mode, even when the FIFO pointers are reset, if there is a DMA transfer in progress, it could push or pop data to or from the FIFO; the DMA itself completes correctly. In order to clear the FIFO, the software should issue an additional FIFO reset and clear any FIFO underrun or overrun errors in the RAWINTS register caused by the DMA transfers after the FIFO was reset.

20.7.5.4 Error Handling

The Module implements error checking; errors are reflected in the RAWINTS register @0x44 and can be communicated to the software through an interrupt, or the software can poll for these bits. Upon power-on, interrupts are disabled (`int_enable` in the CTRL register is 0), and all the interrupts are masked (bits 0-31 of the INTMASK register; default is 0). Error handling:

- Response and data time-out errors - For response time-out, software can retry the command. For data time-out, the Module has not received the data start bit - either for the first block or the intermediate block - within the time-out period, so software can either retry the whole data transfer again or retry from a specified block onwards. By reading the contents of the TCBCNT later, the software can decide how many bytes remain to be copied.
- Response errors - Set when an error is received during response reception. In this case, the response that copied in the response registers is invalid. Software can retry the command.
- Data errors - Set when error in data reception are observed; for example, data CRC, start bit not found, end bit not found, and so on. These errors could be set for any block-first block, intermediate block, or last block. On receipt of an error, the software can issue a STOP or ABORT command and retry the command for either whole data or partial data.
- Hardware locked error - Set when the Module cannot load a command issued by software. When software sets the `start_cmd` bit in the CMD register, the Module tries to load the command. If the command buffer is already filled with a command, this error is raised. The software then has to reload the command.
- FIFO underrun/overrun error - If the FIFO is full and software tries to write data in the FIFO, then an overrun error is set. Conversely, if the FIFO is empty and the software tries to read data from the FIFO, an underrun error is set. Before reading or writing data in the FIFO, the software should read
 - the `fifo_empty` or `fifo_full` bits in the Status register.
- Data starvation by cpu time-out - Raised when the Module is waiting for software intervention to transfer the data to or from the FIFO, but the software does not transfer within the stipulated time-out period. Under this condition and when a read transfer is in process, the software
 - Should read data from the FIFO and create space for further data reception. When a transmit operation is in process, the software should fill data in the FIFO in order to start transferring data to the card.

- CRC Error on Command - If a CRC error is detected for a command, the CE-ATA device does not send a response, and a response time-out is expected from the Module. The ATA layer is notified that an MMC transport layer error occurred.
- Write operation - Any MMC Transport layer error known to the device causes an outstanding ATA command to be terminated. The ERR bits are set in the ATA status registers and the appropriate error code is sent to the ATA Error register.
- If nIEN=0, then the Command Completion Signal (CCS) is sent to the cpu.

If device interrupts are not enabled (nIEN=1), then the device completes the entire Data Unit Count if the cpu controller does not abort the ongoing transfer.

During a multiple-block data transfer, if a negative CRC status is received from the device, the data path signals a data CRC error to the BIU by setting the data CRC error bit in the RINTSTS register. It then continues further data transmission until all the bytes are transmitted.

- Read operation - If MMC transport layer errors are detected by the cpu controller, the cpu completes the ATA command with an error status.

The cpu controller can issue a Command Completion Signal Disable (CCSD) followed by a STOP TRANSMISSION (CMD12) to abort the read transfer. The cpu can also transfer the entire Data Unit Count bytes without aborting the data transfer.

20.7.6 DMA descriptors

The SD/MMC DMA controller uses the following descriptor structures:

- Dual-Buffer Structure – The distance between two descriptors is determined by the Skip Length value programmed in the Descriptor Skip Length (DSL) field of the Bus Mode Register (BMOD).
- Chain Structure – Each descriptor points to a unique buffer and the next descriptor.

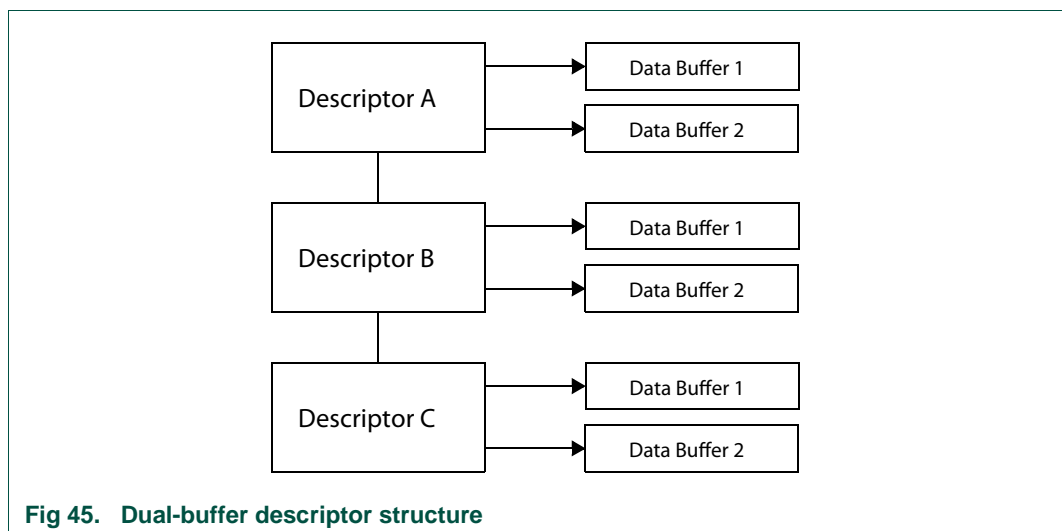

Fig 45. Dual-buffer descriptor structure

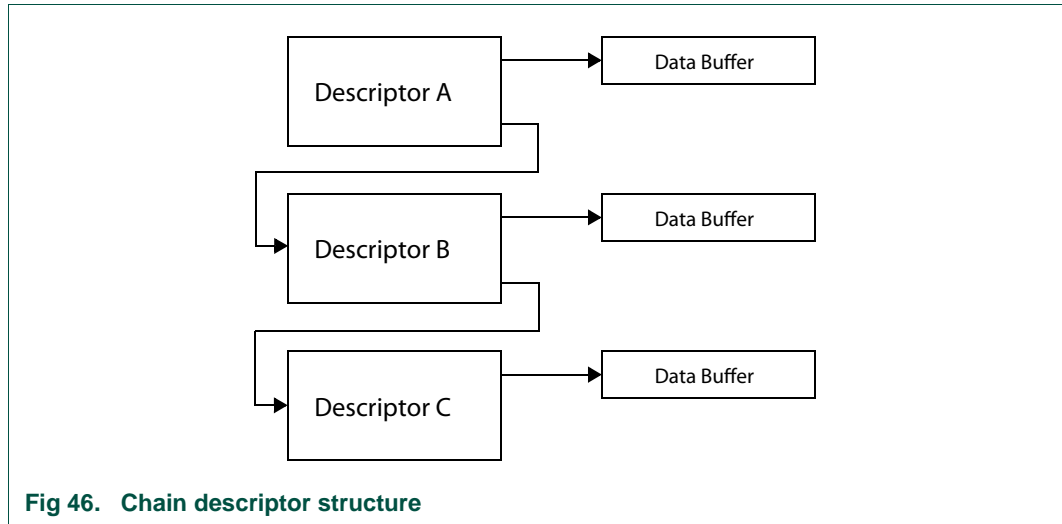

Fig 46. Chain descriptor structure

20.7.6.1 SD/MMC DMA descriptors

20.7.6.1.1 SD/MMC DMA descriptor DESC0

The DESC0 descriptor contains control and status information.

Table 326. SD/MMC DMA DESC0 descriptor

Bit	Symbol	Description
0	-	Reserved
1	DIC	Disable Interrupt on Completion When set, this bit will prevent the setting of the TI/RI bit of the IDMAC Status Register (IDSTS) for the data that ends in the buffer pointed to by this descriptor.
2	LD	Last Descriptor When set, this bit indicates that the buffers pointed to by this descriptor are the last buffers of the data.
3	FS	First Descriptor When set, this bit indicates that this descriptor contains the first buffer of the data. If the size of the first buffer is 0, next Descriptor contains the beginning of the data.
4	CH	Second Address Chained When set, this bit indicates that the second address in the descriptor is the Next Descriptor address rather than the second buffer address. When this bit is set, BS2 (DES1[25:13]) should be all zeros.
5	ER	End of Ring When set, this bit indicates that the descriptor list reached its final descriptor. The IDMAC returns to the base address of the list, creating a Descriptor Ring. This is meaningful for only a dual-buffer descriptor structure.

Table 326. SD/MMC DMA DESC0 descriptor

Bit	Symbol	Description
29:6	-	Reserved
30	CES	Card Error Summary These error bits indicate the status of the transaction to or from the card. These bits are also present in RINTSTS Indicates the logical OR of the following bits: <ul style="list-style-type: none"> • EBE: End Bit Error • RTO: Response Time-out • RCRC: Response CRC • SBE: Start Bit Error • DRTO: Data Read Time-out • DCRC: Data CRC for Receive • RE: Response Error
31	OWN	When set, this bit indicates that the descriptor is owned by the SD/MMC DMA. When this bit is reset, it indicates that the descriptor is owned by the Host. The SD/MMC DMA clears this bit when it completes the data transfer.

20.7.6.1.2 SD/MMC DMA descriptor DESC1

The DES1 descriptor contains the buffer size.

Table 327. SD/MMC DMA DESC1 descriptor

Bit	Symbol	Description
12:0	BS1	Buffer 1 Size Indicates the data buffer byte size, which must be a multiple of 4 bytes. In the case where the buffer size is not a multiple of 4, the resulting behavior is undefined. If this field is 0, the DMA ignores this buffer and proceeds to the next descriptor in case of a chain structure, or to the next buffer in case of a dual-buffer structure. Remark: If there is only one descriptor and only one buffer to be programmed, use only the Buffer 1 and not Buffer 2.
25:13	BS2	Buffer 2 Size These bits indicate the second data buffer byte size. The buffer size must be a multiple of 4. Otherwise, the resulting behavior is undefined. This field is not valid if DES0[4] is set.
31:26	-	Reserved

20.7.6.1.3 SD/MMC DMA descriptor DESC2

The DES2 descriptor contains the address pointer to the data buffer;

Table 328. SD/MMC DMA DESC2 descriptor

Bit	Symbol	Description
31:0	BAP1	Buffer Address Pointer 1 These bits indicate the physical address of the first data buffer. The SD/MMC DMA ignores DES2 [1:0], corresponding to the bus width of 32, internally.

20.7.6.1.4 SD/MMC DMA descriptor DESC3

The DES3 descriptor contains the address pointer to the next descriptor if the present descriptor is not the last descriptor in a chained descriptor structure or the second buffer address for a dual-buffer structure.

Table 329. SD/MMC DMA DESC3 descriptor

Bit	Symbol	Description
31:0	BAP2	<p>Buffer Address Pointer 2/ Next Descriptor Address</p> <p>These bits indicate the physical address of the second buffer when the dual-buffer structure is used. If the Second Address Chained (DES0[4]) bit is set, then this address contains the pointer to the physical memory where the Next Descriptor is present.</p> <p>If this is not the last descriptor, then the Next Descriptor address pointer must be bus-width aligned (DES3[1:0] = 0 , internally the LSBs are ignored).</p>

20.7.6.2 Initialization

For the SD/MMC DMA initialization, follow these steps:

1. Write to the Bus Mode Register (BMOD) to set the Host bus access parameters.
2. Write to the Interrupt Enable Register (IDINTEN) to mask unnecessary interrupt causes.
3. The software driver creates either the Transmit or the Receive descriptor list. Then it writes to Descriptor List Base Address Register (DBADDR), providing the IDMAC with the starting address of the list.
4. The SD/MMC DMA engine attempts to acquire descriptors from the descriptor lists.

20.7.6.3 Host bus burst access

The SD/MMC DMA attempts to execute fixed-length burst transfers on the AHB Master interface if configured using the FB bit of the IDMAC Bus Mode register. The maximum burst length is indicated and limited by the PBL field. The descriptors are always accessed in the maximum possible burst-size for the 16-bytes to be read: $16 \cdot 8 / \text{bus-width}$.

The SD/MMC DMA initiates a data transfer only when sufficient space to accommodate the configured burst is available in the FIFO or the number of bytes to the end of data, when less than the configured burst-length. The SD/MMC DMA indicates the start address and the number of transfers required to the AHB Master Interface. When the AHB Interface is configured for fixed-length bursts, then it transfers data using the best combination of INCR4/8/16 and SINGLE transactions. Otherwise, in no fixed-length bursts, it transfers data using INCR (undefined length) and SINGLE transactions.

20.7.6.4 Host data buffer alignment

The transmit and receive data buffers in host memory must be 32-bit aligned.

20.7.6.5 Buffer size calculations

The driver knows the amount of data to transmit or receive. For transmitting to the card, the IDMAC transfers the exact number of bytes to the FIFO, indicated by the buffer size field of DES1.

If a descriptor is not marked as last - LS bit of DES0 - then the corresponding buffers of the descriptor are full, and the amount of valid data in a buffer is accurately indicated by its buffer size field. If a descriptor is marked as last, then the buffer cannot be full, as indicated by the buffer size in DES1. The driver is aware of the number of locations that are valid in this case.

20.7.6.6 Transmission

The SD/MMC transmission occurs as follows:

1. The Host sets up the Descriptor (DES0-DES3) for transmission and sets the OWN bit (DES0[31]). The Host also prepares the data buffer.
2. The Host programs the write data command in the CMD register in BIU.
3. The Host will also program the required transmit threshold level (TX_WMark field in FIFOTH register).
4. The SD/MMC DMA determines that a write data transfer needs to be done as a consequence of step 2.
5. The SD/MMC DMA engine fetches the descriptor and checks the OWN bit. If the OWN bit is not set, it means that the host owns the descriptor. In this case the SD/MMC DMA enters suspend state and asserts the Descriptor Unable interrupt in the SD/MMC DMA status register (IDSTS). In such a case, the host needs to release the SD/MMC DMA by writing any value to the poll demand register.
6. It will then wait for Command Done (CD) bit and no errors from BIU which indicates that a transfer can be done.
7. The SD/MMC DMA engine will now wait for a DMA interface request from BIU. This request will be generated based on the programmed transmit threshold value. For the last bytes of data which can't be accessed using a burst, SINGLE transfers are performed on AHB Master Interface.
8. The SD/MMC DMA fetches the Transmit data from the data buffer in the Host memory and transfers to the FIFO for transmission to card.
9. When data spans across multiple descriptors, the SD/MMC DMA will fetch the next descriptor and continue with its operation with the next descriptor. The Last Descriptor bit in the descriptor indicates whether the data spans multiple descriptors or not.
10. When data transmission is complete, status information is updated in SD/MMC DMA status register (IDSTS) by setting Transmit Interrupt, if enabled. Also, the OWN bit is cleared by the SD/MMC DMA by performing a write transaction to DES0.

20.7.6.7 Reception

The SD/MMC reception occurs as follows:

1. The Host sets up the Descriptor (DES0-DES3) for reception, sets the OWN (DES0[31]).
2. The Host programs the read data command in the CMD register in BIU.
3. The Host will program the required receive threshold level (RX_WMark field in FIFOTH register).
4. The SD/MMC DMA determines that a read data transfer needs to be done as a consequence of step 2.
5. The SD/MMC DMA engine fetches the descriptor and checks the OWN bit. If the OWN bit is not set, it means that the host owns the descriptor. In this case the DMA enters suspend state and asserts the Descriptor Unable interrupt in the SD/MMC DMA status register (IDSTS). In such a case, the host needs to release the SD/MMC DMA by writing any value to the poll demand register.
6. It will then wait for Command Done (CD) bit and no errors from BIU which indicates that a transfer can be done.

7. The SD/MMC DMA engine will now wait for a DMA interface request (`dw_dma_req`) from BIU. This request will be generated based on the programmed receive threshold value. For the last bytes of data which can't be accessed using a burst, SINGLE transfers are performed on AHB.
8. The SD/MMC DMA fetches the data from the FIFO and transfer to Host memory.
9. When data spans across multiple descriptors, the SD/MMC DMA will fetch the next descriptor and continue with its operation with the next descriptor. The Last Descriptor bit in the descriptor indicates whether the data spans multiple descriptors or not.
10. When data reception is complete, status information is updated in SD/MMC DMA status register (IDSTS) by setting Receive Interrupt, if enabled. Also, the OWN bit is cleared by the SD/MMC DMA by performing a write transaction to DES0.

20.7.6.8 Interrupts

Interrupts can be generated as a result of various events. The SD/MMC DMA Status Register (IDSTS) contains all the bits that might cause an interrupt. The SD/MMC DMA Interrupt Enable Register (IDINTEN) contains an Enable bit for each of the events that can cause an interrupt.

There are two groups of summary interrupts - Normal and Abnormal - as outlined in Status Register (IDSTS). Interrupts are cleared by writing a 1 to the corresponding bit position. When all the enabled interrupts within a group are cleared, the corresponding summary bit is cleared. When both the summary bits are cleared, the interrupt signal is de-asserted.

Interrupts are not queued and if the interrupt event occurs before the driver has responded to it, no additional interrupts are generated. For example, Receive Interrupt (IDSTS[1]) indicates that one or more data was transferred to the Host buffer.

An interrupt is generated only once for simultaneous, multiple events. The driver must scan the SD/MMC DMA Status Register for the interrupt cause.

Remark: The final interrupt (int) signal from created is a logical OR of the interrupt from BIU and SD/MMC DMA.

20.7.6.9 Abort

When the host issues CMD12 when a data transfer on the card data lines is in progress, the FSM closes the present descriptor after completing the transfer of data until a DTO interrupt is asserted. Once an abort command is issued, the DMA performs single burst transfers:

1. When the host issues CMD12 when a data transfer on the card data lines is in progress, the FSM closes the present descriptor after completing the transfer of data until a DTO interrupt is asserted. Once an abort command is issued, the DMAC performs single burst transfers.
2. For a card read, the SD/MMC DMA keeps popping data from FIFO and writes to the host memory until a DTO interrupt is generated. This is required since DTO interrupt is not generated until and unless all the FIFO data is emptied.

Remark: The following scenarios apply for closing the descriptors:

- In case of an FBE, the current descriptor and the remaining unread descriptors are not closed by the SD/MMC DMA.

- In case of a write abort, only the current descriptor during which an abort occurred is closed by the SD/MMC DMA . The remaining unread descriptors are not closed by the IDMAC.
- In case of a read abort, the SD/MMC DMA pops the data out of the FIFO and writes them to the corresponding descriptor data buffers. The remaining unread descriptors are not closed.

20.7.6.10 FBE scenarios

An FBE occurs due to an AHB error response on the AHB bus. This is a system error, so the software driver should not perform any further programming to the SD/MMC. The only recovery mechanism from such scenarios is to do one of the following:

- Issue a hard reset by asserting the reset_n signal .
- Do a program controller reset by writing to the CTRL[0] register .

20.7.6.11 FIFO overflow and underflow

During normal data transfer conditions, FIFO overflow and underflow will not occur. However if there is a programming error, then FIFO overflow/underflow can result. For example, consider the following scenarios.

For transmit: PBL=4, Tx watermark = 1. For these programming values, if the FIFO has only one location empty, it issues a dw_dma_req to DMA state machine. Due to PBL value=4, the DMA performs 4 pushes into the FIFO. This will result in a FIFO overflow interrupt.

For receive: PBL=4, Rx watermark = 1. For these programming values, if the FIFO has only one location filled, it issues a dw_dma_req to the DMA state machine. Due to PBL value=4, the DMA performs 4 pops to the FIFO. This will result in a FIFO underflow interrupt.

The driver should ensure that the number of bytes to be transferred as indicated in the descriptor should be a multiple of 4 bytes. For example, if the BYTCNT = 13, the number of bytes indicated in the descriptor should be 16.

20.7.6.12 Programming of PBL and watermark levels

The SD/MMC DMA performs data transfers depending on the programmed PBL and threshold values. [Table 330](#) lists the allowed programming values.

Table 330. PBL and watermark levels

PBL (number of transfers)	Transmit/receive watermark value
1	greater than or equal to 1
4	greater than or equal to 4
8	greater than or equal to 8
16	greater than or equal to 16
32	greater than or equal to 32
64	greater than or equal to 64
128	greater than or equal to 128
256	greater than or equal to 256

21.1 How to read this chapter

The SPIFI is available on all LPC18xx parts. A software driver library is available on LPCware.com.

See [Section 4.3.6.4 “SPIFI boot mode”](#) for details on the SPIFI boot process.

21.2 Basic configuration

The SPIFI is configured as follows:

- See [Table 331](#) for clocking and power control.
- The SPIFI is reset by the SPIFI_RST (reset # 53).

Table 331. SPIFI clocking and power control

	Base clock	Branch clock	Operating frequency
SPIFI AHB register clock	BASE_M3_CLK	CLK_M3_SPIFI	up to 180 MHz
SPIFI serial clock input	BASE_SPIFI_CLK	SPIFI_CLK	104 MHz

Remark: All LPC18xx parts can use the SPIFI for booting. See [Section 4.3.6.4](#).

21.3 Features

- Quad SPI Flash Interface (SPIFI) interface to external flash.
- Transfer rates of up to SPIFI_CLK/2 bytes per second.
- External flash is directly memory mapped for fast access.
- Supports 1-, 2-, and 4-bit bi-directional serial protocols.
- Transfer protocol compatible with various vendors and devices.
- The SPIFI memory is accessible by the DMA.
- Software driver library available on the LPCware.com website.
- Supports execute-in-place (direct code execution from the SPI Flash memory) and general read/write/erase operations.
- Built-in cache to give high-performance code execution.

21.4 General description

The SPI Flash Interface (SPIFI) allows low pin-count serial flash memories to be connected to an ARM processor with very little performance penalty compared to higher pin-count parallel flash devices. After a few commands configure the interface at startup, the entire flash content is accessible as normal memory using byte, halfword, and word accesses by the processor and/or DMA channels. Erasure and programming are handled by simple sequences of commands. A software API available on LPCware.com provides set-up, programming, and erase functions.

Many SPI flash devices use serial commands for device setup/initialization, and then move to dual or quad commands for normal operation. Different serial Flash vendors and devices accept or require different commands and command formats. SPIFI includes sufficient flexibility to be compatible with many market-leading devices plus extensions to help insure compatibility with future devices.

SPI Flash devices respond to commands sent by software, or automatically sent by the SPIFI when software reads the serial flash region of the memory map. Commands are divided into fields called opcode, address, intermediate data, and data. The address, intermediate data, and data fields are optional depending on the opcode. Some devices include a mode in which the opcode can be implied in Read commands for higher performance. Data fields are further divided into input and output data fields depending on the opcode.

Table 332. SPIFI flash memory map

Memory	Address
SPIFI data	0x1400 0000 to 0x17FF FFFF (Use this memory area for debugging code and for slightly improved performance). 0x8000 0000 to 0x87FF FFFF (Debug will not work if the program counter is in this memory area).
<p>Remark: These are the spaces allocated to the SPIFI in the LPC18xx. The same data appears in the first area and the first half of the second area. These areas allow up to 64 MB and up to 128 MB of SPI flash to be mapped into the Cortex-M3 memory space. In practice, the usable space is limited to the size of the connected device.</p>	

21.5 Pin description

Table 333. SPIFI pin description

Pin function	Direction	Description
SPIFI_SCK	O	Serial clock for the flash memory, switched only during active bits on the MOSI/IO0, MISO/IO1, and IO3:2 lines.
SPIFI_CS	O	Chip select for the flash memory, driven LOW while a command is in progress, and high between commands.
SPIFI_MOSI or IO0	I/O	This is an output except in quad/dual input data fields. After a quad/dual input data field, it becomes an output again one serial clock period after CS goes high.
SPIFI_MISO or IO1	I/O	This is an output in quad/dual opcode, address, intermediate, and output data fields, and an input in SPI mode and in quad/dual input data fields. After an input data field in quad/dual mode, it becomes an output again one serial clock period after CS goes high.
SPIFI_SIO[3:2]	I/O	These are outputs in quad opcode, address, intermediate, and output data fields, and inputs in quad input data fields. These pins (or any other GPIO pins) may be used, when not in quad mode, as software controlled Hold and/or WPn controls for flash memories that support those functions.

21.6 Register description

The SPIFI register interface supports word accesses.

Table 334. Register overview: SPIFI (base address 0x4000 3000)

Name	Access	Address offset	Description	Reset value
CTRL	R/W	0x000	SPIFI control register	0x400F FFFF
CMD	R/W	0x004	SPIFI command register	0x0000 0000
ADDR	R/W	0x008	SPIFI address register	0x0000 0000
IDATA	R/W	0x00C	SPIFI intermediate data register	0x0000 0000
CLIMIT	R/W	0x010	SPIFI cache limit register	0x0800 0000
DATA	R/W	0x014	SPIFI data register	0x0000 0000
MCMD	R/W	0x018	SPIFI memory command register	0x0000 0000
STAT	R/W	0x01C	SPIFI status register	0x0200 0000

21.6.1 SPIFI control register

The SPIFI control register controls the overall operation of the SPIFI and should be written before any commands are initiated.

Table 335. SPIFI control register (CTRL, address 0x4000 3000) bit description

Bit	Symbol	Value	Description	Reset value
15:0	TIMEOUT		This field contains the number of serial clock periods without the processor reading data in memory mode, which will cause the SPIFI hardware to terminate the command by driving the CS pin high and negating the CMD bit in the Status register. (This allows the flash memory to enter a lower-power state.) If the processor reads data from the flash region after a time-out, the command in the Memory Command Register is issued again.	0xFFFF
19:16	CSHIGH		This field controls the minimum \overline{CS} high time, expressed as a number of serial clock periods minus one.	1111
20	-		Reserved.	-
21	D_PRFTCH_DIS		This bit allows conditioning of memory mode prefetches based on the AHB HPROT (instruction/data) access information. A 1 in this register means that the SPIFI will not attempt a speculative prefetch when it encounters data accesses.	0
22	INTEN		If this bit is 1 when a command ends, the SPIFI will assert its interrupt request output. See INTRQ in the status register for further details.	0
23	MODE3		SPI Mode 3 select.	0
		0	SCK LOW. The SPIFI drives SCK low after the rising edge at which the last bit of each command is captured, and keeps it low while \overline{CS} is HIGH.	
		1	SCK HIGH. The SPIFI keeps SCK high after the rising edge for the last bit of each command and while \overline{CS} is HIGH, and drives it low after it drives \overline{CS} LOW. (Known serial flash devices can handle either mode, but some devices may require a particular mode for proper operation.) Remark: MODE3, RFCLK, and FBCLK should not all be 1, because in this case there is no final falling edge on SCK on which to sample the last data bit of the frame.	
26:24	-		Reserved.	-

Table 335. SPIFI control register (CTRL, address 0x4000 3000) bit description

Bit	Symbol	Value	Description	Reset value
27	PRFTCH_DIS		Cache prefetching enable. The SPIFI includes an internal cache. A 1 in this bit disables prefetching of cache lines.	0
		0	Enable. Cache prefetching enabled.	
		1	Disable. Disables prefetching of cache lines.	
28	DUAL		Select dual protocol.	0
		0	Quad protocol. This protocol uses IO3:0.	
		1	Dual protocol. This protocol uses IO1:0.	
29	RFCLK		Select active clock edge for input data.	0
		0	Rising edge. Read data is sampled on rising edges on the clock, as in classic SPI operation.	
		1	Falling edge. Read data is sampled on falling edges of the clock, allowing a full serial clock of time in order to maximize the serial clock frequency. Remark: MODE3, RFCLK, and FBCLK should not all be 1, because in this case there is no final falling edge on SCK on which to sample the last data bit of the frame.	
30	FBCLK		Feedback clock select.	1
		0	Internal clock. The SPIFI samples read data using an internal clock.	
		1	Feedback clock. Read data is sampled using a feedback clock from the SCK pin. This allows slightly more time for each received bit. Remark: MODE3, RFCLK, and FBCLK should not all be 1, because in this case there is no final falling edge on SCK on which to sample the last data bit of the frame.	
31	DMAEN		A 1 in this bit enables the DMA Request output from the SPIFI. Set this bit only when a DMA channel is used to transfer data in peripheral mode. Do not set this bit when a DMA channel is used for memory-to-memory transfers from the SPIFI memory area. DRQEN should only be used in Command mode.	0

21.6.2 SPIFI command register

The Command Register may only be written as a word, but bytes, halfwords, and words may be read from it. It may be written to when the CMD and MCINIT bits in the Status register are 0, and under these circumstances writing initiates the transmission of a new command. For a command that contains an address and/or intermediate data, software should write to the Address and/or Intermediate Data registers, before writing to this register. If the command contains output data, software should write it to the Data Register after writing to this register. If the command contains input data, software can read it from the Data Register after writing to this register.

Table 336. SPIFI command register (CMD, address 0x4000 3004) bit description

Bit	Symbol	Value	Description	Reset value
13:0	DATALEN		Except when the POLL bit in this register is 1, this field controls how many data bytes are in the command. 0 indicates that the command does not contain a data field.	0
14	POLL		This bit should be written as 1 only with an opcode that a) contains an input data field, and b) causes the serial flash device to return byte status repetitively (e.g., a Read Status command). When this bit is 1, the SPIFI hardware continues to read bytes until the test specified by the dataLen field is met. The hardware tests the bit in each status byte selected by DATALEN bits 2:0, until a bit is found that is equal to DATALEN bit 3. When the test succeeds, the SPIFI captures the byte that meets this test so that it can be read from the Data Register, and terminates the command by raising CS. The end-of-command interrupt can be enabled to inform software when this occurs	0
15	DOUT		If the DATALEN field is not zero, this bit controls the direction of the data:	0
		0	Input from serial flash.	
		1	Output to serial flash.	
18:16	INTLEN		This field controls how many intermediate bytes precede the data. (Each such byte may require 8 or 2 SCK cycles, depending on whether the intermediate field is in serial, 2-bit, or 4-bit format.) Intermediate bytes are output by the SPIFI, and include post-address control information, dummy and delay bytes. See the description of the Intermediate Data register for the contents of such bytes.	0
20:19	FIELDFORM		This field controls how the fields of the command are sent.	0
		0x0	All serial. All fields of the command are serial.	
		0x1	Quad/dual data. Data field is quad/dual, other fields are serial.	
		0x2	Serial opcode. Opcode field is serial. Other fields are quad/dual.	
		0x3	All quad/dual. All fields of the command are in quad/dual format.	
23:21	FRAMEFORM		This field controls the opcode and address fields.	0
		0x0	Reserved.	
		0x1	Opcode only, no address.	
		0x2	Opcode, least significant byte of address.	
		0x3	Opcode, two least significant bytes of address.	
		0x4	Opcode, three least significant bytes of address.	
		0x5	Opcode, 4 bytes of address.	
		0x6	No opcode, 3 least significant bytes of address.	
		0x7	No opcode, 4 bytes of address.	
31:24	OPCODE		The opcode of the command (not used for some FRAMEFORM values).	0

21.6.3 SPIFI address register

Before writing a command that includes an address field to the Command register, software should write the address to this register. The most significant byte of the address is sent first.

Table 337. SPIFI address register (ADDR, address 0x4000 3008) bit description

Bit	Symbol	Description	Reset value
31:0	ADDRESS	Address.	0

21.6.4 SPIFI intermediate data register

Before writing a command to the Command register that requires specific intermediate byte values, software should write the value of the bytes to this register. The least significant byte of this register is sent first. If more than four intermediate bytes are specified in the Command register, zeroes are sent after the 4th byte.

The main use of this register with current serial flash devices is to select the no-opcode mode (continuous read, code execution) using the byte value 0xA5, and cancelling this mode using 0xFF.

Many devices that require dummy (delay) bytes don't care about their contents, in which case this register need not be written.

Table 338. SPIFI intermediate data register (IDATA, address 0x4000 300C) bit description

Bit	Symbol	Description	Reset value
31:0	IDATA	Value of intermediate bytes.	0

21.6.5 SPIFI cache limit register

The SPIFI hardware includes caching of previously-accessed data to improve performance. Software can write an address within the device to this register, to prevent such caching at and above that address. After Reset this register contains the allocated size of the SPIFI memory area, so that all possible accesses are below that value and are thus cacheable.

Table 339. SPIFI cache limit register (CLIMIT, address 0x4000 3010) bit description

Bit	Symbol	Description	Reset value
31:0	CLIMIT	Zero-based upper limit of cacheable memory	0x0800 0000

21.6.6 SPIFI data register

After initiating a command that includes a data output field by writing to the Command Register, software should write output data to this register. Store Byte instructions provide one data byte, Store Halfword instructions provide two bytes, and Store Word instructions provide 4 bytes of output data. Store commands are waited if the FIFO is too full to accept the number of bytes being stored. For Store Halfword and Store Word, the least significant byte is sent first.

After initiating a command that includes a data input field by writing to the Command Register, software should read input data from this register. Load Byte instructions deliver one data byte to software, Load Halfword instructions deliver two bytes, and Load Word instructions deliver 4 bytes of input data. Load commands are waited if a command is in progress and the FIFO does not contain the number of bytes being loaded. For Load Halfword and Load Word commands, the least significant byte is received first.

DATALEN bytes should be read from or written to this register. If such a (read or write) command needs to be terminated before that time, software should write a 1 to the RESET bit in the Status register to accomplish this. If software attempts to read or write more data than was specified in DATALEN, a Data Abort exception will occur.

In polling mode (see the POLL bit in the SPIFI command register), one byte must be read from this register because the poll mechanism writes the matching byte.

This register is not used for commands initiated by reading the flash address range in the memory map. In DMA transfers in peripheral to-or-from-memory mode, the address of this register should be used as the peripheral address.

Table 340. SPIFI Data register (DATA, address 0x4000 3014) bit description

Bit	Symbol	Description	Reset value
31:0	DATA	Input or output data	0

21.6.7 SPIFI memory command register

Before accessing the flash area of the memory map, software should set up the device. After optionally writing to the Intermediate Data register, software should write a word to this register to define the command that is used to read data. Thereafter data can be read from the flash memory area, either directly or by means of a DMA channel.

Writing to this register will be ignored when a command is in progress or while data has yet to be written or read from the FIFO for a command issued. Use the MCINIT bit of the Status register to verify that the hardware is in Memory mode. A successful write to this register sets the SPIFI into Memory mode. The content of this register is identical to that of the Command Register, except for the DATALEN (not used), POLL, DOUT, and FRAMEFORM bits.

Table 341. SPIFI memory command register (MCMD, address 0x4000 3018) bit description

Bit	Symbol	Value	Description	Reset value
13:0	-		Reserved.	0
14	POLL		This bit should be written as 0.	0
15	DOUT		This bit should be written as 0.	0
18:16	INTLEN		This field controls how many intermediate bytes precede the data. (Each such byte may require 8 or 2 SCK cycles, depending on whether the intermediate field is in serial, 2-bit, or 4-bit format.) Intermediate bytes are output by the SPIFI, and include post-address control information, dummy and delay bytes. See the description of the Intermediate Data register for the contents of such bytes.	0

Table 341. SPIFI memory command register (MCMD, address 0x4000 3018) bit description

Bit	Symbol	Value	Description	Reset value
20:19	FIELDFORM		This field controls how the fields of the command are sent.	0
		0x0	All serial. All fields of the command are serial.	
		0x1	Quad/dual data. Data field is quad/dual, other fields are serial.	
		0x2	Serial opcode. Opcode field is serial. Other fields are quad/dual.	
		0x3	All quad/dual. All fields of the command are in quad/dual format.	
23:21	FRAMEFORM		This field controls the opcode and address fields.	0
		0x0	Reserved.	
		0x1	Reserved.	
		0x2	Opcode, least-significant byte of address.	
		0x3	Opcode, 2 least-significant bytes of address.	
		0x4	Opcode, 3 least-significant bytes of address.	
		0x5	Opcode, 4 bytes of address.	
		0x6	No opcode, 3 least-significant bytes of address.	
0x7	No opcode, 4 bytes of address.			
31:24	OPCODE		The opcode of the command (not used for some FRAMEFORM values).	0

21.6.8 SPIFI status register

This register indicates the state of the SPIFI.

Table 342. SPIFI status register (STAT, address 0x4000 301C) bit description

Bit	Symbol	Description	Reset value
0	MCINIT	This bit is set when software successfully writes the Memory Command register, and is cleared by Reset or by writing a 1 to the RESET bit in this register.	0
1	CMD	This bit is 1 when the Command register is written. It is cleared by a hardware reset, a write to the RESET bit in this register, or the deassertion of \overline{CS} which indicates that the command has completed communication with the SPI Flash.	0
3:2		Reserved	0
4	RESET	Write a 1 to this bit to abort a current command or memory mode. This bit is cleared when the hardware is ready for a new command to be written to the Command register.	
5	INTRQ	This bit reflects the SPIFI interrupt request. Write a 1 to this bit to clear it. This bit is set when a CMD was previously 1 and has been cleared due to the deassertion of CS.	5
23:6	-	Reserved	0
31:24	VERSION	The SPIFI hardware described in this chapter returns	0x02

21.7 Functional description

21.7.1 Data transfer

Serial SPI uses the signals SPIFI_SCK, $\overline{\text{SPIFI_CS}}$, SPIFI_MISO, and SPIFI_MISO, while quad mode adds the two IO signals SPIFI_SIO[3:2].

The SPIFI implements basic, dual, and quad SPI in half-duplex mode, in which the SPIFI always sends a command to a serial flash memory at the start of each frame. (A frame is the sequence of bytes transmitted during one period with $\overline{\text{CS}}$ LOW.) In general, commands start with an opcode byte although some serial flashes allow a no-opcode mode in which commands start with the address to be read. In write commands, the SPIFI sends all of the data in the frame, while in read commands, the SPIFI sends the command, and then the serial flash sends data to the SPIFI.

Classic SPI includes four modes (mode 0 to mode 3), of which the SPIFI and most serial flashes implement modes 0 and 3. In mode 0, the SCK line is LOW between frames while in mode 3 it is HIGH. In mode 0, the SPIFI drives the first data bits from the time that it drives $\overline{\text{CS}}$ LOW, and drives the rest of the data on falling edges of SCK. In mode 3, the SPIFI drives SCK LOW one-half clock period after it drives $\overline{\text{CS}}$ LOW, and drives data on the falling edge of SCK. In either mode the serial flash samples the data on the rising edges of SCK.

The same scheme (transmitter changes data on falling edges of SCK, receiver samples data on rising edges) is maintained for the entire frame, including read data sent by the serial flash to the SPIFI.

The SPI protocol avoids all issues of set-up and hold times between the clock and data lines by using half of the SCK period to transmit the data. For high clock speeds, it is necessary to sample read data using a feedback clock. The FBCLK bit enables the feedback clock from the SCK pad sampling method. This provides the best possible timing margin for both read and write data under the opposite-edge scheme.

But maximizing clock frequency is of such importance that further improvement is sometimes needed, by means of using the whole serial clock period to transmit data. This choice is enabled for read data by setting the RFCLK bit. When this bit is 1, the SPIFI samples data on the falling edge of the serial clock that follows the rising edge which is normally used. RFCLK and FBCLK and MODE3 should not all be 1 because in this case there would be no falling edge of the feedback clock to capture the last bit of a frame.

Consult the datasheet of the serial flash device to be used for the formats of the commands that it supports. [Figure 47](#) shows commands consisting of an opcode field only, sent in SPI and quad modes. All fields are multiples of 8 bits long. Bytes are sent with the most significant bit first in SPI mode, and the most significant 4 bits first in quad mode.

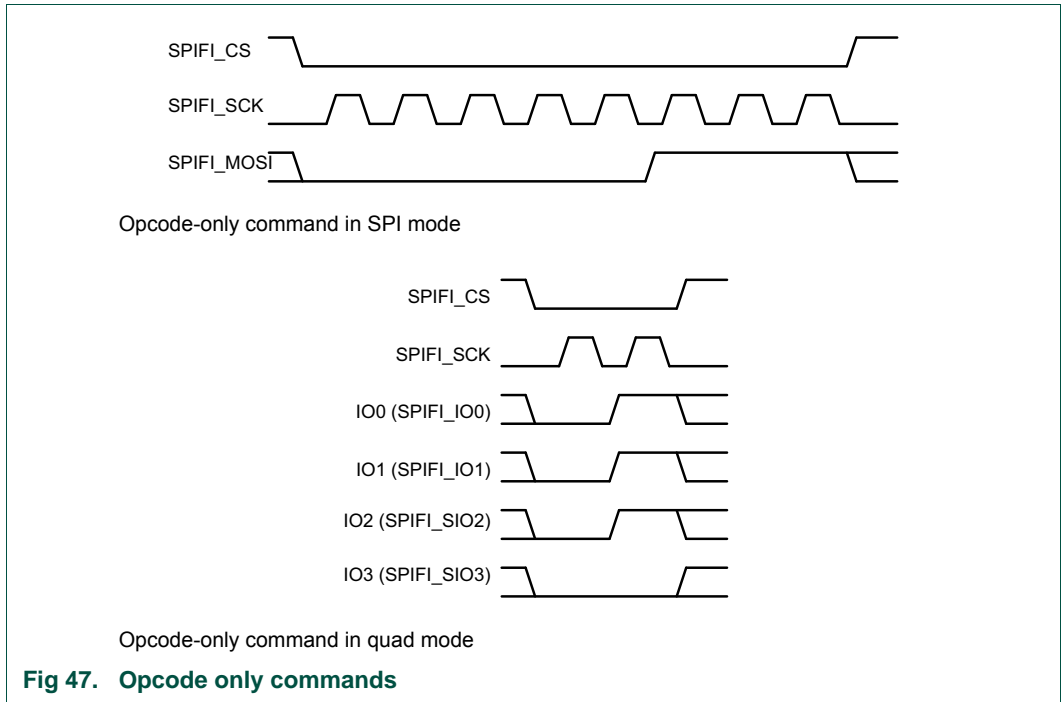
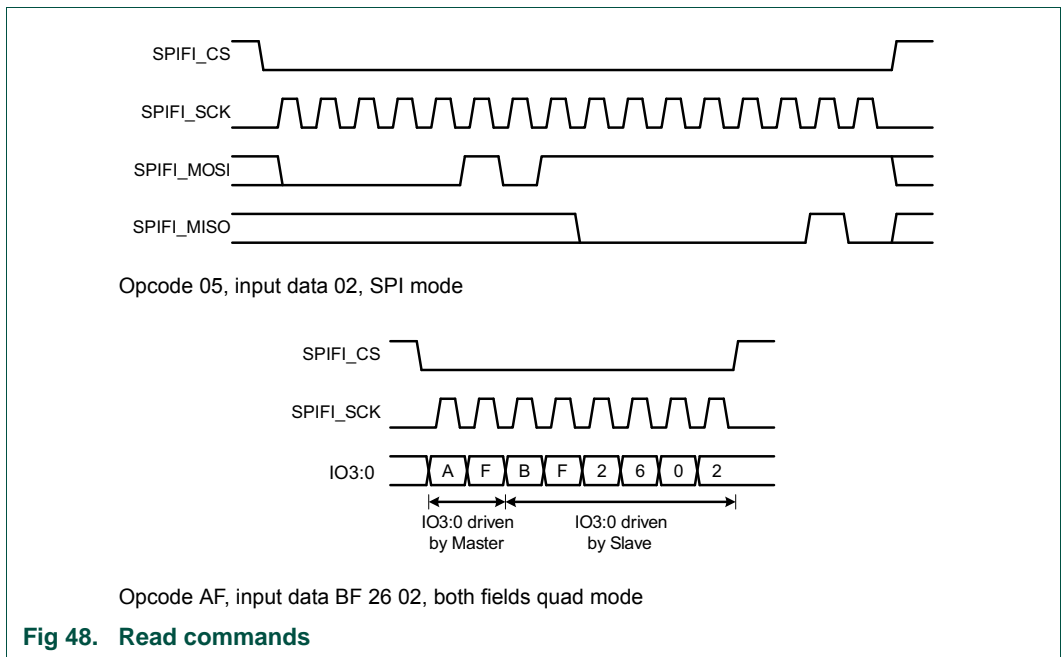

Figure 48 shows a command that reads 1 byte from the slave in SPI mode and a command that reads 3 bytes from the slave with the opcode and input data fields both in quad mode.



In quad mode, the IO3:0 lines are driven by the SPIFI in opcode, address, intermediate and output data fields, and driven by the flash memory in input data fields. In address fields the more significant bytes are sent first.

21.7.2 Software requirements and capabilities

During device set-up, software should initialize the external serial flash device using those commands that place it in its highest-performance mode. When this sequence is complete, software should write the command that will be issued in response to a read from the serial flash region of the memory map, to the Memory Command Register. If software attempts to read the flash region after Reset, power-up, or writing the Command Register without writing the Memory Command Register thereafter, the SPIFI responds with an Abort error.

After writing the Memory Command Register, the contents of the flash would appear to the system as memory mapped. This enables data access or execution from the serial flash over AHB.

SPIFI has two operational modes:

1. Memory Mode - whereby the contents of the FLASH are memory mapped in the chip.
2. Command Mode - whereby the user can manually construct command sequences for the flash.

SPIFI cannot switch over from Memory Mode to Command mode and vice versa without writing 1 to the RESET bit in the SPIFI Status Register and polling until it is cleared by hardware to ensure that the current mode has been aborted.

The SPIFI includes a cache to maximize performance for accesses to the serial flash region of the memory map. The cache is only used in Memory mode and can be disabled.

Because the SPIFI is an AHB device, software or a DMA channel can read bytes, halfwords, or words from the flash region.

Reads from the flash region are delayed by deasserting HREADY when necessary, until the requested bytes are available to be read.

In Memory mode, SPIFI prefetches sequential addresses in order to improve performance.

If no AHB accesses have taken place for a period specified by the time-out (TO) field in the Control register, the SPIFI will deassert CS. Once a new access occurs that requires a new fetch of data, the SPIFI will reassert CS and send a new command to fetch the required data. This is done in order to save power in the SPI flash device.

If software reads or writes more data from the Data Register than was configured in the DataLen field of the Command register or reads or writes when no command was issued, the SPIFI hardware issues an abort exception.

When the serial flash needs to be programmed or erased, software should not write to the flash region of the address map. Instead, it should write the appropriate sequence of commands to the Command, Address, and Data registers. When an actual erase or program operation is under way in the serial flash device, software should write a Read Status command (with the POLL bit set) to the Command register. Thereafter:

- If INTEN in the Control register is 1, the SPIFI will interrupt the processor when the erase or write operation (and thus the Read Status command) completes.
- If not, software can continually or periodically read the Status register until it indicates that the Read Status command is complete.

When erasing or programming completes, software can do further programming or erasing, or return to normal (memory mode) operation.

21.7.3 Peripheral mode DMA operation

The SPIFI inserts wait states when necessary during read and write operations by the core to maintain synchronization between core accesses and serial data transfer with the serial flash. This mechanism is all that is needed for load and store accesses and for memory-to-memory transfers by a DMA channel.

The peripheral mode is a mode that supports DMA transfers in which the SPIFI acts as a peripheral and drives a request signal to the DMA channel to control data transfer. This mode does not necessarily move data faster than memory-to-memory operation, but it may be advantageous in systems in which software controls dynamic transfer of code and/or data between the serial flash and RAM on an as-needed basis. The advantage is that clock cycles are not lost to wait states, and thus the overall operation of the AHB is more efficient.

The DMA controller should be programmed to present word operations at the fixed address of the Data Register to have a burst size of one transfer. The SPIFI drives the DMA request to the DMA controller.

To use this mode, software should write the Command register to start the command and program a DMA channel as described above to transfer data between the Data register and RAM. The SPIFI asserts the DMA request when:

- DRQEN in the Control register is 1.
- MCINIT is 0.
- There are at least 4 bytes in the FIFO for a read operation, or at least 4 empty byte locations in the FIFO for a write/program operation.

22.1 How to read this chapter

The EMC is available on all LPC18xx parts.

The memory and address bus widths depend on package size.

Table 343. EMC pinout for different packages

Function	LBGA256	TFBGA180	TFBGA100	LQFP208	LQFP144
A	EMC_A[23:0]	EMC_A[23:0]	EMC_A[13:0]	EMC_A[23:0]	EMC_A[15:0]
D	EMC_D[31:0]	EMC_D[15:0]	EMC_D[7:0]	EMC_D[15:0]	EMC_D[15:0]
BLS	$\overline{\text{EMC_BLS}}[3:0]$	$\overline{\text{EMC_BLS}}[3:0]$	$\overline{\text{EMC_BLS}}0$	$\overline{\text{EMC_BLS}}[1:0]$	$\overline{\text{EMC_BLS}}[1:0]$
CS	$\overline{\text{EMC_CS}}[3:0]$	$\overline{\text{EMC_CS}}[3:0]$	$\overline{\text{EMC_CS}}0$	$\overline{\text{EMC_CS}}[3:0]$	$\overline{\text{EMC_CS}}[1:0]$
OE	$\overline{\text{EMC_OE}}$	$\overline{\text{EMC_OE}}$	$\overline{\text{EMC_OE}}$	$\overline{\text{EMC_OE}}$	$\overline{\text{EMC_OE}}$
WE	$\overline{\text{EMC_WE}}$	$\overline{\text{EMC_WE}}$	$\overline{\text{EMC_WE}}$	$\overline{\text{EMC_WE}}$	$\overline{\text{EMC_WE}}$
CKEOUT	EMC_CKEOUT[3:0]	EMC_CKEOUT[1:0]	EMC_CKEOUT[1:0]	EMC_CKEOUT[1:0]	EMC_CKEOUT[1:0]
CLK	EMC_CLK[3:0]; EMC_CLK01, EMC_CLK23	EMC_CLK0, EMC_CLK3; EMC_CLK01, EMC_CLK23	EMC_CLK0, EMC_CLK3; EMC_CLK01, EMC_CLK23	EMC_CLK0, EMC_CLK3; EMC_CLK01, EMC_CLK23	EMC_CLK0, EMC_CLK3; EMC_CLK01, EMC_CLK23
DQMOUT	EMC_DQMOUT[3:0]	EMC_DQMOUT[1:0]	-	EMC_DQMOUT[1:0]	EMC_DQMOUT[1:0]
DYCS	$\overline{\text{EMC_DYCS}}[3:0]$	$\overline{\text{EMC_DYCS}}[1:0]$	$\overline{\text{EMC_DYCS}}[1:0]$	$\overline{\text{EMC_DYCS}}[2:0]$	$\overline{\text{EMC_DYCS}}[1:0]$
CAS	$\overline{\text{EMC_CAS}}$	$\overline{\text{EMC_CAS}}$	$\overline{\text{EMC_CAS}}$	$\overline{\text{EMC_CAS}}$	$\overline{\text{EMC_CAS}}$
RAS	$\overline{\text{EMC_RAS}}$	$\overline{\text{EMC_RAS}}$	$\overline{\text{EMC_RAS}}$	$\overline{\text{EMC_RAS}}$	$\overline{\text{EMC_RAS}}$

22.2 Basic configuration

The External Memory Controller is configured as follows:

- See [Table 344](#) for clocking and power control. Two clocks are supported:
 - BASE_M3_CLK
 - 1/2 x BASE_M3_CLK

If the EMC clock EMC_CCLK is configured for 1/2 x BASE_M3_CLK, the CLK_M3_EM_DIV branch clock must be configured for half-frequency clock operation in both the CREG6 register ([Table 96](#)) and the CCU1 CLK_EMCDIV_CFG register ([Table 148](#)).

- All four EMC_CLK clock signals must be configured for all SDRAM devices by selecting the EMC_CLK function and enabling the input buffer (EZI = 1) in all four SFSClKn registers in the SCU.
- The EMC is reset by the EMC_RST (reset # 21).

- Program the SDRAM Delay value for the EMC_CLKn lines in the EMCDELAYCLK register in the SCU block. (See [Section 16.4.9.](#)) Add the SDRAM delay for most SDRAM devices running at frequencies above 96 MHz under typical conditions. Add the SDRAM delay at any frequency to compensate for variations over temperature. For details, see the *LPC1850_30_20_10 data sheet*.

Table 344. EMC clocking and power control

	Base clock	Branch clock	Operating frequency	Notes
EMC registers and EMC clock EMC_CCLK	BASE_M3_CLK	CLK_M3_EMC	up to 180 MHz	The maximum operating frequency depends on temperature and voltage settings and is typically 120 MHz for SDRAM devices. For details, see the LPC18xx data sheets.
EMC clock EMC_CCLK (divided clock)	BASE_M3_CLK	CLK_M3_EMC_DIV	up to 180 MHz	This is an alternative clock option for EMC_CCLK. This clock can run at the same frequency as BASE_M3_CLK or at half the frequency of BASE_M3_CLK.

22.3 Features

- 8-bit, 16-bit, and 32-bit wide static memory support with up to four chip selects.
- Asynchronous static memory device support including RAM, ROM, and NOR Flash, with or without asynchronous page mode.
- Static memory features include:
 - Asynchronous page mode read
 - Programmable wait states
 - Bus turnaround delay
 - Output enable and write enable delays
 - Extended wait
- 16-bit and 32-bit wide chip select SDRAM memory support with up to four chip selects and up to 256 MB of data.
- Controller supports 2 kbit, 4 kbit, and 8 kbit row address synchronous memory parts. That is typical 512 MB, 256 MB, and 128 MB parts, with 4, 8, 16, or 32 data bits per device.
- Dynamic memory interface support including Single Data Rate SDRAM. SDRAM maximum frequency of up to 120 MHz.
- Dynamic memory self-refresh mode controlled by software.
- Power-saving modes dynamically control EMC_CKEOUT and EMC_CLK to SDRAMs.
- Low transaction latency.
- Read and write buffers to reduce latency and to improve performance.
- Separate reset domains allow the for auto-refresh through a chip reset if desired.
- Programmable delay elements allow to fine-tune the EMC timing.

Remark: Synchronous static memory devices (synchronous burst mode) are not supported.

22.4 General description

The LPC18xx External Memory Controller (EMC) is an ARM PrimeCell MultiPort Memory Controller peripheral offering support for asynchronous static memory devices such as RAM, ROM and Flash, as well as dynamic memories such as Single Data Rate SDRAM.

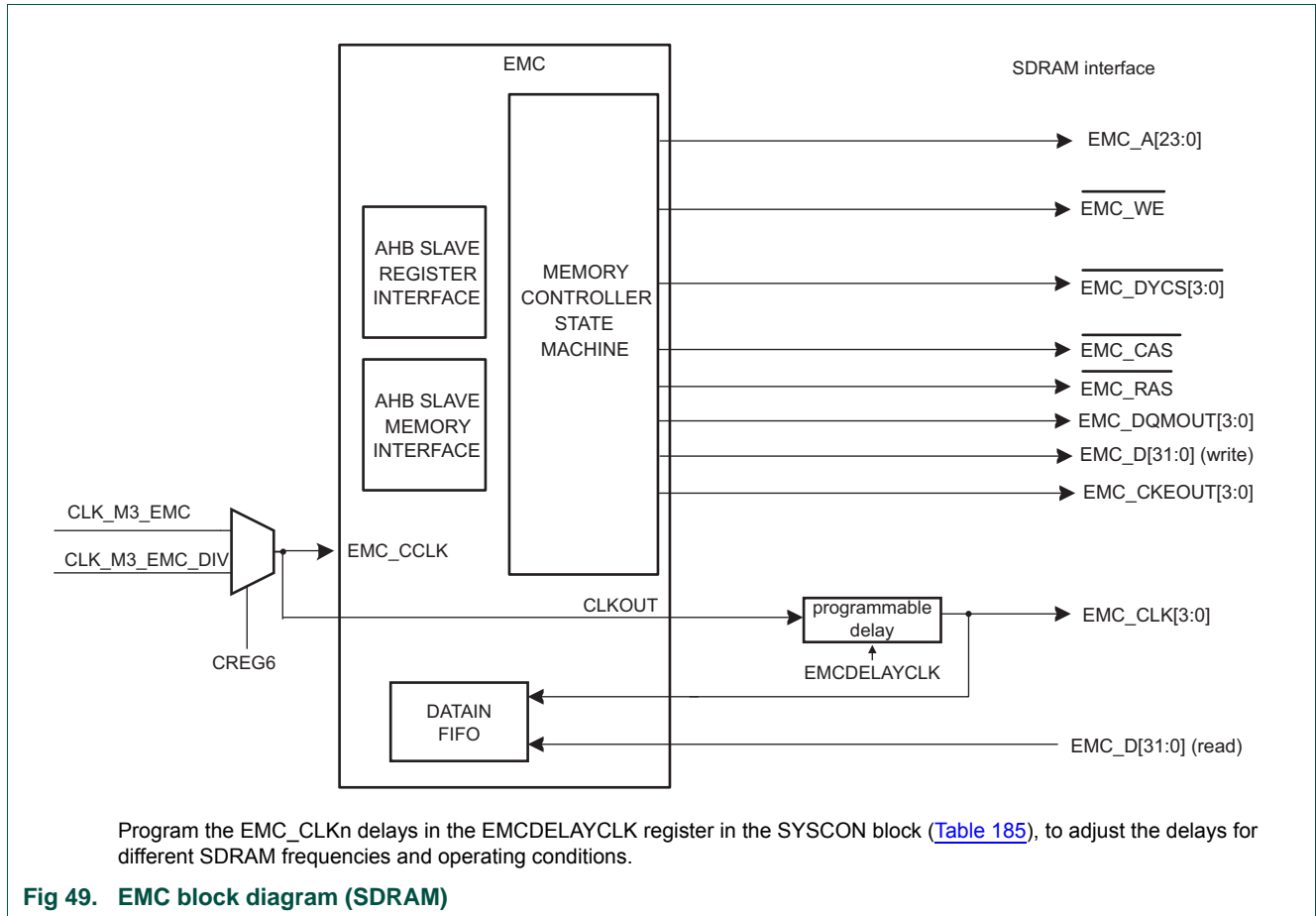

The EMC has four ports that connect to the bus masters as follows (in order of priority, 1 = top):

1. LCD controller
2. M3 S-bus
3. M3 I/D-bus
4. Other bus masters

Lower priority requests are only serviced when no higher priority requests are active. Same priority requests are serviced in turn (round-robin arbitration).

Static memories are mapped below 0x2000 0000. This memory area is addressed by the M3 I/D-bus.

Dynamic memories are mapped above 0x1FFF FFFF. This memory area is addressed by the M3 S-bus. When the M3 core is executing from SDRAM not much bandwidth is remaining for lower priority bus masters (other bus masters except for the LCD controller).

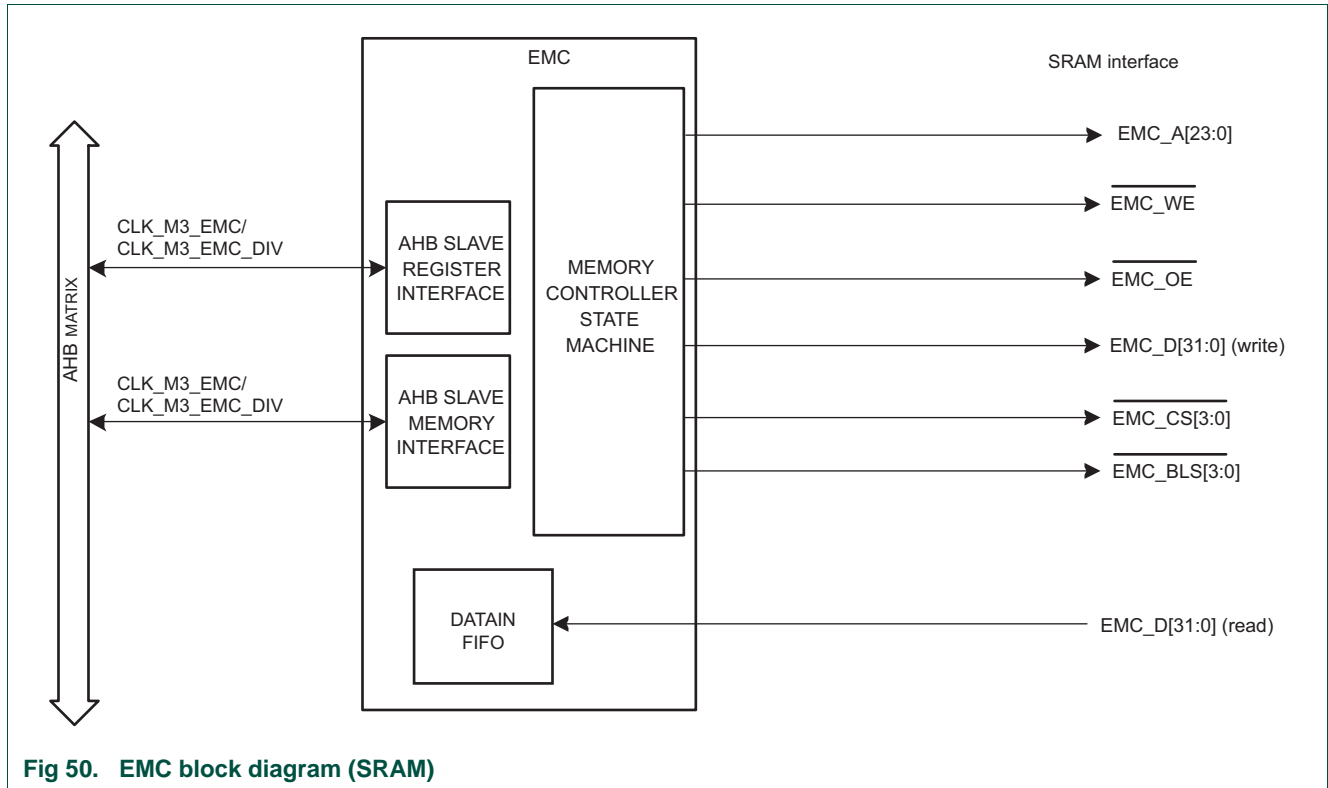

Fig 50. EMC block diagram (SRAM)

22.4.1 Memory bank select

Eight independently-configurable memory chip selects are supported:

- Pins $\overline{\text{EMC_CS3}}$ to $\overline{\text{EMC_CS0}}$ are used to select static memory devices.
- Pins $\overline{\text{EMC_DYCS3}}$ to $\overline{\text{EMC_DYCS0}}$ are used to select dynamic memory devices.

Static memory chip select ranges are each 16 MB in size, while dynamic memory chip selects cover a range of 256 MB each. [Table 345](#) shows the address ranges of the chip selects.

Table 345. Memory bank selection

Chip select pin	Address range	Memory type	Size of range
$\overline{\text{EMC_CS0}}$	0x1C00 0000 - 0x1CFF FFFF	Static	16 MB
$\overline{\text{EMC_CS1}}$	0x1D00 0000 - 01DFF FFFF	Static	16 MB
$\overline{\text{EMC_CS2}}$	0x1E00 0000 - 0x1EFF FFFF	Static	16 MB
$\overline{\text{EMC_CS3}}$	0x1F00 0000 - 0x1FFF FFFF	Static	16 MB
$\overline{\text{EMC_DYCS0}}$	0x2800 0000 - 0x2FFF FFFF	Dynamic	128 MB
$\overline{\text{EMC_DYCS1}}$	0x3000 0000 - 0x3FFF FFFF	Dynamic	256 MB
$\overline{\text{EMC_DYCS2}}$	0x6000 0000 - 0x6FFF FFFF	Dynamic	256 MB
$\overline{\text{EMC_DYCS3}}$	0x7000 0000 - 0x7FFF FFFF	Dynamic	256 MB

22.5 Pin description

Table 346. EMC pin description

Pin function	Direction	Description
EMC_A[23:0]	O	Address bus
EMC_D[31:0]	I/O	Data bus
EMC_BLS[3:0]	O	Byte lane select
EMC_CS[3:0]	O	Static RAM memory bank select
EMC_OE	O	Output enable
EMC_WE	O	Write enable
EMC_CKEOUT[3:0]	O	SDRAM clock enable signals
EMC_CLK[3:0]; EMC_CLK01; EMC_CLK23	O	SDRAM clock signals
EMC_DQMOUT[3:0]	O	Data mask output to SDRAM memory banks
EMC_DYCS[3:0]	O	SDRAM memory bank select
EMC_CAS	O	Column address strobe
EMC_RAS	O	Row address strobe

22.6 Register description

This chapter describes the EMC registers and provides details required when programming the microcontroller. The EMC registers are shown in [Table 347](#). Reset value reflects the data stored in used bits only. It does not include the content of reserved bits.

Table 347. Register overview: External memory controller (base address 0x4000 5000)

Name	Access	Address offset	Description	Reset value	Reset value after EMC boot	Reference
CONTROL	R/W	0x000	Controls operation of the memory controller.	0x3	[1] 0x1	Table 348
STATUS	RO	0x004	Provides EMC status information.	0x5	0x5	Table 349
CONFIG	R/W	0x008	Configures operation of the memory controller.	0	0	Table 350
-	-	0x00C - 0x01C	Reserved.	-	-	-
DYNAMICCONTROL	R/W	0x020	Controls dynamic memory operation.	0x6	0x6	Table 351
DYNAMICREFRESH	R/W	0x024	Configures dynamic memory refresh operation.	0	0	Table 352
DYNAMICREADCONFIG	R/W	0x028	Configures the dynamic memory read strategy.	0	0	Table 353
-	-	0x02C	Reserved.	-	-	-
DYNAMICCRP	R/W	0x030	Selects the precharge command period.	0xF	0xF	Table 354

Table 347. Register overview: External memory controller (base address 0x4000 5000) ...continued

Name	Access	Address offset	Description	Reset value	Reset value after EMC boot	Reference
DYNAMICRAS	R/W	0x034	Selects the active to precharge command period.	0xF	0xF	Table 355
DYNAMICSREX	R/W	0x038	Selects the self-refresh exit time.	0xF	0xF	Table 356
DYNAMICAPR	R/W	0x03C	Selects the last-data-out to active command time.	0xF	0xF	Table 357
DYNAMICDAL	R/W	0x040	Selects the data-in to active command time.	0xF	0xF	Table 358
DYNAMICWR	R/W	0x044	Selects the write recovery time.	0xF	0xF	Table 359
DYNAMICRC	R/W	0x048	Selects the active to active command period.	0x1F	0x1F	Table 360
DYNAMICRFC	R/W	0x04C	Selects the auto-refresh period.	0x1F	0x1F	Table 361
DYNAMICXSR	R/W	0x050	Selects the exit self-refresh to active command time.	0x1F	0x1F	Table 362
DYNAMICRRD	R/W	0x054	Selects the active bank A to active bank B latency.	0xF	0xF	Table 363
DYNAMICMRD	R/W	0x058	Selects the load mode register to active command time.	0xF	0xF	Table 364
-	R/W	0x05C - 0x07C	Reserved.	-	-	-
STATICEXTENDEDWAIT	R/W	0x080	Selects time for long static memory read and write transfers.	0	0	Table 365
-	R/W	-	Reserved.	-	-	-
DYNAMICCONFIG0	R/W	0x100	Selects the configuration information for dynamic memory chip select 0.	0	0	Table 366
DYNAMICRASCAS0	R/W	0x104	Selects the RAS and CAS latencies for dynamic memory chip select 0.	0x303	0x303	Table 368
-		0x108 - 0x11C	Reserved.	-	-	-
DYNAMICCONFIG1	R/W	0x120	Selects the configuration information for dynamic memory chip select 1.	0	0	Table 366
DYNAMICRASCAS1	R/W	0x124	Selects the RAS and CAS latencies for dynamic memory chip select 1.	0x303	0x303	Table 368
-	-	0x128 - 0x13C	Reserved.	-	-	-
DYNAMICCONFIG2	R/W	0x140	Selects the configuration information for dynamic memory chip select 2.	0	0	Table 366
DYNAMICRASCAS2	R/W	0x144	Selects the RAS and CAS latencies for dynamic memory chip select 2.	0x303	0x303	Table 368
-	-	0x148 - 0x15C	Reserved.	-	-	-
DYNAMICCONFIG3	R/W	0x160	Selects the configuration information for dynamic memory chip select 3.	0	0	Table 366

Table 347. Register overview: External memory controller (base address 0x4000 5000) ...continued

Name	Access	Address offset	Description	Reset value	Reset value after EMC boot	Reference
DYNAMICRASCAS3	R/W	0x164	Selects the RAS and CAS latencies for dynamic memory chip select 3.	0x303	0x303	Table 368
-	-	0x168 - 0x1FC	Reserved.	-	-	-
STATICCONFIG0	R/W	0x200	Selects the memory configuration for static chip select 0.	0	0x81	Table 369
STATICWAITWEN0	R/W	0x204	Selects the delay from chip select 0 to write enable.	0	0	Table 370
STATICWAITOEN0	R/W	0x208	Selects the delay from chip select 0 or address change, whichever is later, to output enable.	0	0	Table 371
STATICWAITRD0	R/W	0x20C	Selects the delay from chip select 0 to a read access.	0x1F	0xE ^[2]	Table 372
STATICWAITPAGE0	R/W	0x210	Selects the delay for asynchronous page mode sequential accesses for chip select 0.	0x1F	0x1F	Table 373
STATICWAITWR0	R/W	0x214	Selects the delay from chip select 0 to a write access.	0x1F	0x1F	Table 374
STATICWAITTURN0	R/W	0x218	Selects the number of bus turnaround cycles for chip select 0.	0xF	0xF	Table 375
-	-	0x21C	Reserved.	-	-	-
STATICCONFIG1	R/W	0x220	Selects the memory configuration for static chip select 1.	0	0	Table 369
STATICWAITWEN1	R/W	0x224	Selects the delay from chip select 1 to write enable.	0	0	Table 370
STATICWAITOEN1	R/W	0x228	Selects the delay from chip select 1 or address change, whichever is later, to output enable.	0	0	Table 371
STATICWAITRD1	R/W	0x22C	Selects the delay from chip select 1 to a read access.	0x1F	0x1F	Table 372
STATICWAITPAGE1	R/W	0x230	Selects the delay for asynchronous page mode sequential accesses for chip select 1.	0x1F	0x1F	Table 373
STATICWAITWR1	R/W	0x234	Selects the delay from chip select 1 to a write access.	0x1F	0x1F	Table 374
STATICWAITTURN1	R/W	0x238	Selects the number of bus turnaround cycles for chip select 1.	0xF	0xF	Table 375
-	-	0x23C	Reserved.	-	-	-
STATICCONFIG2	R/W	0x240	Selects the memory configuration for static chip select 2.	0	0	Table 369
STATICWAITWEN2	R/W	0x244	Selects the delay from chip select 2 to write enable.	0	0	Table 370

Table 347. Register overview: External memory controller (base address 0x4000 5000) ...continued

Name	Access	Address offset	Description	Reset value	Reset value after EMC boot	Reference
STATICWAITOEN2	R/W	0x248	Selects the delay from chip select 2 or address change, whichever is later, to output enable.	0	0	Table 371
STATICWAITRD2	R/W	0x24C	Selects the delay from chip select 2 to a read access.	0x1F	0x1F	Table 372
STATICWAITPAGE2	R/W	0x250	Selects the delay for asynchronous page mode sequential accesses for chip select 2.	0x1F	0x1F	Table 373
STATICWAITWR2	R/W	0x254	Selects the delay from chip select 2 to a write access.	0x1F	0x1F	Table 374
STATICWAITTURN2	R/W	0x258	Selects the number of bus turnaround cycles for chip select 2.	0xF	0xF	Table 375
-	-	0x25C	Reserved.	-	-	-
STATICCONFIG3	R/W	0x260	Selects the memory configuration for static chip select 3.	0	0	Table 369
STATICWAITWEN3	R/W	0x264	Selects the delay from chip select 3 to write enable.	0	0	Table 370
STATICWAITOEN3	R/W	0x268	Selects the delay from chip select 3 or address change, whichever is later, to output enable.	0	0	Table 371
STATICWAITRD3	R/W	0x26C	Selects the delay from chip select 3 to a read access.	0x1F	0x1F	Table 372
STATICWAITPAGE3	R/W	0x270	Selects the delay for asynchronous page mode sequential accesses for chip select 3.	0x1F	0x1F	Table 373
STATICWAITWR3	R/W	0x274	Selects the delay from chip select 3 to a write access.	0x1F	0x1F	Table 374
STATICWAITTURN3	R/W	0x278	Selects the number of bus turnaround cycles for chip select 3.	0xF	0xF	Table 375

[1] The reset value after warm reset for the CONTROL register is 0x0000 0001.

[2] For booting from external memory, see [Section 4.3.6.2 "EMC boot mode"](#).

22.6.1 EMC Control register

The Control register is a read/write register that controls operation of the memory controller. The control bits can be altered during normal operation.

Table 348. EMC Control register (CONTROL - address 0x4000 5000) bit description

Bit	Symbol	Value	Description	Reset value
0	E		EMC Enable. Indicates if the EMC is enabled or disabled. Disabling the EMC reduces power consumption. When the memory controller is disabled the memory is not refreshed. The memory controller is enabled by setting the enable bit, or by reset. This bit must only be modified when the EMC is in idle state. [1]	1
		0	Disabled	
		1	Enabled (POR and warm reset value).	
1	M		Address mirror. Indicates normal or reset memory map. On POR, CS1 is mirrored to both CS0 and DYCS0 memory areas. Clearing the M bit enables CS0 and DYCS0 memory to be accessed.	1
		0	Normal memory map.	
		1	Reset memory map. Static memory CS1 is mirrored onto CS0 and DYCS0 (POR reset value).	
2	L		Low-power mode. Indicates normal, or low-power mode. Entering low-power mode reduces memory controller power consumption. Dynamic memory is refreshed as necessary. The memory controller returns to normal functional mode by clearing the low-power mode bit (L), or by POR. This bit must only be modified when the EMC is in idle state. [1]	0
		0	Normal mode (warm reset value).	
		1	Low-power mode.	
31:3	-	-	Reserved, user software should not write ones to reserved bits. The value read from a reserved bit is not defined.	-

[1] The external memory cannot be accessed in low-power or disabled state. If a memory access is performed an AHB error response is generated. The EMC registers can be programmed in low-power and/or disabled state.

22.6.2 EMC Status register

The read-only Status register provides EMC status information.

Table 349. EMC Status register (STATUS - address 0x4000 5004) bit description

Bit	Symbol	Value	Description	Reset value
0	B		Busy. This bit is used to ensure that the memory controller enters the low-power or disabled mode cleanly by determining if the memory controller is busy or not:	1
		0	EMC is idle (warm reset value).	
		1	EMC is busy performing memory transactions, commands, auto-refresh cycles, or is in self-refresh mode (POR reset value).	
1	S		Write buffer status. This bit enables the EMC to enter low-power mode or disabled mode cleanly:	0
		0	Write buffers empty (POR reset value)	
		1	Write buffers contain data.	

Table 349. EMC Status register (STATUS - address 0x4000 5004) bit description

Bit	Symbol	Value	Description	Reset value
2	SA		Self-refresh acknowledge. This bit indicates the operating mode of the EMC:	1
		0	Normal mode	
		1	Self-refresh mode (POR reset value).	
31:3	-	-	Reserved, user software should not write ones to reserved bits. The value read from a reserved bit is not defined.	-

22.6.3 EMC Configuration register

This register configures the operation of the memory controller. It is recommended that this register is modified during system initialization, or when there are no current or outstanding transactions. This can be ensured by waiting until the EMC is idle, and then entering low-power, or disabled mode. This register is accessed with one wait state.

Table 350. EMC Configuration register (CONFIG - address 0x4000 5008) bit description

Bit	Symbol	Value	Description	Reset value
0	EM		Endian mode. On power-on reset, the value of the endian bit is 0. All data must be flushed in the EMC before switching between little-endian and big-endian modes.	0
		0	Little-endian mode (POR reset value).	
		1	Big-endian mode.	
7:1	-	-	Reserved, user software should not write ones to reserved bits. The value read from a reserved bit is not defined.	-
8	-	-	Reserved. Always write a 0 to this bit.	0
31:9	-	-	Reserved, user software should not write ones to reserved bits. The value read from a reserved bit is not defined.	-

22.6.4 Dynamic Memory Control register

This register controls dynamic memory operation. The control bits can be altered during normal operation.

Table 351. Dynamic Control register (DYNAMICCONTROL - address 0x4000 5020) bit description

Bit	Symbol	Value	Description	Reset value
0	CE		Dynamic memory clock enable.	0
		0	Clock enable of idle devices are deasserted to save power (POR reset value).	
		1	All clock enables are driven HIGH continuously. [1]	
1	CS		Dynamic memory clock control. When clock control is LOW the output clock CLKOUT is stopped when there are no SDRAM transactions. The clock is also stopped during self-refresh mode.	1
		0	CLKOUT stops when all SDRAMs are idle and during self-refresh mode.	
		1	CLKOUT runs continuously (POR reset value).	

Table 351. Dynamic Control register (DYNAMICCONTROL - address 0x4000 5020) bit description

Bit	Symbol	Value	Description	Reset value
2	SR		Self-refresh request, EMC SREFREQ. By writing 1 to this bit self-refresh can be entered under software control. Writing 0 to this bit returns the EMC to normal mode. The self-refresh acknowledge bit in the Status register must be polled to discover the current operating mode of the EMC. [2]	1
		0	Normal mode.	
		1	Enter self-refresh mode (POR reset value).	
4:3	-	-	Reserved, user software should not write ones to reserved bits. The value read from a reserved bit is not defined.	-
5	MMC		Memory clock control.	0
		0	CLKOUT enabled (POR reset value).	
		1	CLKOUT disabled. [3]	
6	-	-	Reserved, user software should not write ones to reserved bits. The value read from a reserved bit is not defined.	-
8:7	I		SDRAM initialization.	00
		0x0	Issue SDRAM NORMAL operation command (POR reset value).	
		0x1	Issue SDRAM MODE command.	
		0x2	Issue SDRAM PALL (precharge all) command.	
		0x3	Issue SDRAM NOP (no operation) command)	
13:9	-	-	Reserved, user software should not write ones to reserved bits. The value read from a reserved bit is not defined.	-
31:14	-	-	Reserved, user software should not write ones to reserved bits. The value read from a reserved bit is not defined.	-

[1] Clock enable must be HIGH during SDRAM initialization.

[2] The memory controller exits from power-on reset with the self-refresh bit HIGH. To enter normal functional mode set this bit LOW.

[3] Disabling CLKOUT can be performed if there are no SDRAM memory transactions. When enabled this bit can be used in conjunction with the dynamic memory clock control (CS) field.

22.6.5 Dynamic Memory Refresh Timer register

This register configures dynamic memory operation. Set up the length of each refresh cycle according to the EMC_CCLK frequency and the SDRAM specification during system initialization, or when there are no current or outstanding transactions. This can be ensured by waiting until the EMC is idle, and then entering low-power, or disabled mode.

While the EMC is running, the refresh cycle time can be adjusted to compensate for a changing EMC_CCLK frequency. The EMC controller might skip one refresh cycle in this case.

Always adjust the refresh cycle time so that the appropriate number of refresh cycles fit in the refresh time. Both the number of refresh cycles and the refresh time t_{REF} are given in the SDRAM data sheet.

This register is used for all four dynamic memory chip selects. Therefore the worst case value for all of the chip selects must be programmed.

Table 352. Dynamic Memory Refresh Timer register (DYNAMICREFRESH - address 0x4000 5024) bit description

Bit	Symbol	Description	Reset value
10:0	REFRESH	Refresh timer. Indicates the multiple of 16 EMC_CCLKs between SDRAM refresh cycles. 0x0 = Refresh disabled (POR reset value). 0x1 - 0x7FF = n x16 = 16n EMC_CCLKs between SDRAM refresh cycles. For example: 0x1 = 1 x 16 = 16 EMC_CCLKs between SDRAM refresh cycles. 0x8 = 8 x 16 = 128 EMC_CCLKs between SDRAM refresh cycles	0
31:11	-	Reserved, user software should not write ones to reserved bits. The value read from a reserved bit is not defined.	-

For example, for the refresh period of 16 μ s, and a EMC_CCLK frequency of 50 MHz, the following value must be programmed into this register:

$$(16 \times 10^{-6} \times 50 \times 10^6) / 16 = 50 \text{ or } 0x32$$

If auto-refresh through warm reset is requested (by setting the EMC_Reset_Disable bit), the timing of auto-refresh must be adjusted to allow a sufficient refresh rate when the clock rate is reduced during the wake-up period of a reset cycle. During this period, the EMC (and all other portions of the chip that are being clocked) run from the IRC oscillator at 12 MHz. The IRC oscillator frequency must be used as the EMC_CCLK rate for refresh calculations if auto-refresh through warm reset is requested.

Note: The refresh cycles are evenly distributed. However, there might be slight variations when the auto-refresh command is issued depending on the status of the memory controller.

22.6.6 Dynamic Memory Read Configuration register

This register configures the dynamic memory read strategy. This register must be modified during system initialization with a bit value $RD \geq 1$. This register is accessed with one wait state.

Note: This register is used for all four dynamic memory chip selects. Therefore the worst case value for all of the chip selects must be programmed.

Remark: Choose command delay strategy ($RD = 0x1$) for SDRAM operation.

See [Section 16.4.9](#) for programming the delay value for the EMC_CLKn delay.

Table 353. Dynamic Memory Read Configuration register (DYNAMICREADCONFIG - address 0x4000 5028) bit description

Bit	Symbol	Value	Description	Reset value
1:0	RD		Read data strategy.	0x0
		0x0	Do not use. POR reset value.	
		0x1	Command delayed by 1/2 EMC_CCLK.	
		0x2	Command delayed by 1/2 EMC_CCLK plus one clock cycle.	
		0x3	Command delayed by 1/2 EMC_CCLK plus two clock cycles.	
31:2	-	-	Reserved, user software should not write ones to reserved bits. The value read from a reserved bit is not defined.	-

22.6.7 Dynamic Memory Precharge Command Period register

This register enables you to program the precharge command period, tRP. This register must only be modified during system initialization. This value is normally found in SDRAM data sheets as tRP. This register is accessed with one wait state.

Note: This register is used for all four dynamic memory chip selects. Therefore the worst case value for all of the chip selects must be programmed.

Table 354. Dynamic Memory Precharge Command Period register (DYNAMICRP - address 0x4000 5030) bit description

Bit	Symbol	Description	Reset value
3:0	TRP	Precharge command period. 0x0 - 0xE = n + 1 clock cycles. The delay is in EMC_CCLK cycles. 0xF = 16 clock cycles (POR reset value).	0xF
31:4	-	Reserved, user software should not write ones to reserved bits. The value read from a reserved bit is not defined.	-

22.6.8 Dynamic Memory Active to Precharge Command Period register

This register enables you to program the active to precharge command period, tRAS. It is recommended that this register is modified during system initialization, or when there are no current or outstanding transactions. This can be ensured by waiting until the EMC is idle, and then entering low-power, or disabled mode. This value is normally found in SDRAM data sheets as tRAS. This register is accessed with one wait state.

Note: This register is used for all four dynamic memory chip selects. Therefore the worst case value for all of the chip selects must be programmed.

Table 355. Dynamic Memory Active to Precharge Command Period register (DYNAMICRAS - address 0x4000 5034) bit description

Bit	Symbol	Description	Reset value
3:0	TRAS	Active to precharge command period. 0x0 - 0xE = n + 1 clock cycles. The delay is in EMC_CCLK cycles. 0xF = 16 clock cycles (POR reset value).	0xF
31:4	-	Reserved, user software should not write ones to reserved bits. The value read from a reserved bit is not defined.	-

22.6.9 Dynamic Memory Self Refresh Exit Time register

This register enables you to program the self-refresh exit time, tSREX. It is recommended that this register is modified during system initialization, or when there are no current or outstanding transactions. This can be ensured by waiting until the EMC is idle, and then entering low-power, or disabled mode. This value is normally found in SDRAM data sheets as tSREX, for devices without this parameter you use the same value as tXSR. This register is accessed with one wait state.

Note: This register is used for all four dynamic memory chip selects. Therefore the worst case value for all of the chip selects must be programmed.

Table 356. Dynamic Memory Self Refresh Exit Time register (DYNAMICSREX - address 0x4000 5038) bit description

Bit	Symbol	Description	Reset value
3:0	TSREX	Self-refresh exit time. 0x0 - 0xE = n + 1 clock cycles. The delay is in EMC_CCLK cycles. 0xF = 16 clock cycles (POR reset value).	0xF
31:4	-	Reserved, user software should not write ones to reserved bits. The value read from a reserved bit is not defined.	-

22.6.10 Dynamic Memory Last Data Out to Active Time register

This register enables you to program the last-data-out to active command time, tAPR. It is recommended that this register is modified during system initialization, or when there are no current or outstanding transactions. This can be ensured by waiting until the EMC is idle, and then entering low-power, or disabled mode. This value is normally found in SDRAM data sheets as tAPR. This register is accessed with one wait state.

Note: This register is used for all four dynamic memory chip selects. Therefore the worst case value for all of the chip selects must be programmed.

Table 357. Dynamic Memory Last Data Out to Active Time register (DYNAMICAPR - address 0x4000 503C) bit description

Bit	Symbol	Description	Reset value
3:0	TAPR	Last-data-out to active command time. 0x0 - 0xE = n + 1 clock cycles. The delay is in EMC_CCLK cycles. 0xF = 16 clock cycles (POR reset value).	0xF
31:4	-	Reserved, user software should not write ones to reserved bits. The value read from a reserved bit is not defined.	-

22.6.11 Dynamic Memory Data In to Active Command Time register

This register enables you to program the data-in to active command time, tDAL. It is recommended that this register is modified during system initialization, or when there are no current or outstanding transactions. This can be ensured by waiting until the EMC is idle, and then entering low-power, or disabled mode. This value is normally found in SDRAM data sheets as tDAL, or tAPW. This register is accessed with one wait state.

Note: This register is used for all four dynamic memory chip selects. Therefore the worst case value for all of the chip selects must be programmed.

Table 358. Dynamic Memory Data In to Active Command Time register (DYNAMICDAL - address 0x4000 5040) bit description

Bit	Symbol	Description	Reset value
3:0	TDAL	Data-in to active command. 0x0 - 0xE = n clock cycles. The delay is in EMC_CCLK cycles. 0xF = 15 clock cycles (POR reset value).	0xF
31:4	-	Reserved, user software should not write ones to reserved bits. The value read from a reserved bit is not defined.	-

22.6.12 Dynamic Memory Write Recovery Time register

This register enables you to program the write recovery time, tWR. It is recommended that this register is modified during system initialization, or when there are no current or outstanding transactions. This can be ensured by waiting until the EMC is idle, and then entering low-power, or disabled mode. This value is normally found in SDRAM data sheets as tWR, tDPL, tRWL, or tRDL. This register is accessed with one wait state.

Note: This register is used for all four dynamic memory chip selects. Therefore the worst case value for all of the chip selects must be programmed.

Table 359. Dynamic Memory Write Recovery Time register (DYNAMICWR - address 0x4000 5044) bit description

Bit	Symbol	Description	Reset value
3:0	TWR	Write recovery time. 0x0 - 0xE = n + 1 clock cycles. The delay is in EMC_CCLK cycles. 0xF = 16 clock cycles (POR reset value).	0xF
31:4	-	Reserved, user software should not write ones to reserved bits. The value read from a reserved bit is not defined.	-

22.6.13 Dynamic Memory Active to Active Command Period register

This register enables you to program the active to active command period, tRC. It is recommended that this register is modified during system initialization, or when there are no current or outstanding transactions. This can be ensured by waiting until the EMC is idle, and then entering low-power, or disabled mode. This value is normally found in SDRAM data sheets as tRC. This register is accessed with one wait state.

Note: This register is used for all four dynamic memory chip selects. Therefore the worst case value for all of the chip selects must be programmed.

Table 360. Dynamic Memory Active to Active Command Period register (DYNAMICRC - address 0x4000 5048) bit description

Bit	Symbol	Description	Reset value
4:0	TRC	Active to active command period. 0x0 - 0x1E = n + 1 clock cycles. The delay is in EMC_CCLK cycles. 0x1F = 32 clock cycles (POR reset value).	0x1F
31:5	-	Reserved, user software should not write ones to reserved bits. The value read from a reserved bit is not defined.	-

22.6.14 Dynamic Memory Auto-refresh Period register

This register enables you to program the auto-refresh period, and auto-refresh to active command period, tRFC. It is recommended that this register is modified during system initialization, or when there are no current or outstanding transactions. This can be ensured by waiting until the EMC is idle, and then entering low-power, or disabled mode. This value is normally found in SDRAM data sheets as tRFC, or sometimes as tRC. This register is accessed with one wait state.

Note: This register is used for all four dynamic memory chip selects. Therefore the worst case value for all of the chip selects must be programmed.

Table 361. Dynamic Memory Auto Refresh Period register (DYNAMICRFC - address 0x4000 504C) bit description

Bit	Symbol	Description	Reset value
4:0	TRFC	Auto-refresh period and auto-refresh to active command period. 0x0 - 0x1E = n + 1 clock cycles. The delay is in EMC_CCLK cycles. 0x1F = 32 clock cycles (POR reset value).	0x1F
31:5	-	Reserved, user software should not write ones to reserved bits. The value read from a reserved bit is not defined.	-

22.6.15 Dynamic Memory Exit Self Refresh register

This register enables you to program the exit self-refresh to active command time, tXSR. It is recommended that this register is modified during system initialization, or when there are no current or outstanding transactions. This can be ensured by waiting until the EMC is idle, and then entering low-power, or disabled mode. This value is normally found in SDRAM data sheets as tXSR. This register is accessed with one wait state.

Note: This register is used for all four dynamic memory chip selects. Therefore the worst case value for all of the chip selects must be programmed.

Table 362. Dynamic Memory Exit Self Refresh register (DYNAMICXSR - address 0x4000 5050) bit description

Bit	Symbol	Description	Reset value
4:0	TXSR	Exit self-refresh to active command time. 0x0 - 0x1E = n + 1 clock cycles. The delay is in EMC_CCLK cycles. 0x1F = 32 clock cycles (POR reset value).	0x1F
31:5	-	Reserved, user software should not write ones to reserved bits. The value read from a reserved bit is not defined.	-

22.6.16 Dynamic Memory Active Bank A to Active Bank B Time register

This register enables you to program the active bank A to active bank B latency, tRRD. It is recommended that this register is modified during system initialization, or when there are no current or outstanding transactions. This can be ensured by waiting until the EMC is idle, and then entering low-power, or disabled mode. This value is normally found in SDRAM data sheets as tRRD. This register is accessed with one wait state.

Note: This register is used for all four dynamic memory chip selects. Therefore the worst case value for all of the chip selects must be programmed.

Table 363. Dynamic Memory Active Bank A to Active Bank B Time register (DYNAMICRRD - address 0x4000 5054) bit description

Bit	Symbol	Description	Reset value
3:0	TRRD	Active bank A to active bank B latency 0x0 - 0xE = n + 1 clock cycles. The delay is in EMC_CCLK cycles. 0xF = 16 clock cycles (POR reset value).	0xF
31:4	-	Reserved, user software should not write ones to reserved bits. The value read from a reserved bit is not defined.	-

22.6.17 Dynamic Memory Load Mode register to Active Command Time

This register enables you to program the load mode register to active command time, tMRD. It is recommended that this register is modified during system initialization, or when there are no current or outstanding transactions. This can be ensured by waiting until the EMC is idle, and then entering low-power, or disabled mode. This value is normally found in SDRAM data sheets as tMRD, or tRSA. This register is accessed with one wait state.

Note: This register is used for all four dynamic memory chip selects. Therefore the worst case value for all of the chip selects must be programmed.

Table 364. Dynamic Memory Load Mode register to Active Command Time (DYNAMICMRD - address 0x4000 5058) bit description

Bit	Symbol	Description	Reset value
3:0	TMRD	Load mode register to active command time. 0x0 - 0xE = n + 1 clock cycles. The delay is in EMC_CCLK cycles. 0xF = 16 clock cycles (POR reset value).	0xF
31:4	-	Reserved, user software should not write ones to reserved bits. The value read from a reserved bit is not defined.	-

22.6.18 Static Memory Extended Wait register

This register is used to time long static memory read and write transfers when the ExtendedWait (EW) bit in the StaticConfig register is set. It is recommended that this register is modified during system initialization, or when there are no current or outstanding transactions. However, if necessary, these control bits can be altered during normal operation. This register is accessed with one wait state.

Table 365. Static Memory Extended Wait register (STATICEXTENDEDWAIT - address 0x4000 5080) bit description

Bit	Symbol	Description	Reset value
9:0	EXTENDEDWAIT	Extended wait time out. 16 clock cycles (POR reset value). The delay is in EMC_CCLK cycles. 0x0 = 16 clock cycles. 0x1 - 0x3FF = (n+1) x16 clock cycles.	0x0
31:10	-	Reserved, user software should not write ones to reserved bits. The value read from a reserved bit is not defined.	-

For example, for a static memory read/write transfer time of 16 μ s, and a EMC_CCLK frequency of 50 MHz, the following value must be programmed into this register:
 $(16 \times 10^{-6} \times 50 \times 10^6) / 16 - 1 = 49$.

22.6.19 Dynamic Memory Configuration registers

These registers enable you to program the configuration information for the relevant dynamic memory chip select. These registers are normally only modified during system initialization. These registers are accessed with one wait state.

Table 366. Dynamic Memory Configuration registers (DYNAMICCONFIG[0:3], address 0x4000 5100 (DYNAMICCONFIG0), 0x4000 5120 (DYNAMICCONFIG1), 0x4000 5140 (DYNAMICCONFIG2), 0x4000 5160 (DYNAMICCONFIG3)) bit description

Bit	Symbol	Value	Description	Reset value
2:0	-	-	Reserved, user software should not write ones to reserved bits. The value read from a reserved bit is not defined.	-
4:3	MD		Memory device.	0
		0x0	SDRAM (POR reset value).	
		0x1	Reserved.	
		0x2	Reserved.	
		0x3	Reserved.	
6:5	-	-	Reserved, user software should not write ones to reserved bits. The value read from a reserved bit is not defined.	-
12:7	AM0		Address mapping. See Table 367 . 000000 = reset value. ^[1]	0
13	-	-	Reserved, user software should not write ones to reserved bits. The value read from a reserved bit is not defined.	-
14	AM1		Address mapping. See Table 367 . 0 = reset value.	0
18:15	-	-	Reserved, user software should not write ones to reserved bits. The value read from a reserved bit is not defined.	-
19	B		Buffer enable.	
		0	Buffer disabled for accesses to this chip select (POR reset value).	
		1	Buffer enabled for accesses to this chip select. After configuration of the dynamic memory, the buffer must be enabled for normal operation. ^[2]	
20	P		Write protect.	0
		0	Writes not protected (POR reset value).	
		1	Writes protected.	
31:21	-	-	Reserved, user software should not write ones to reserved bits. The value read from a reserved bit is not defined.	-

[1] The SDRAM column and row width and number of banks are computed automatically from the address mapping.

[2] The buffers must be disabled during SDRAM initialization. The buffers must be enabled during normal operation.

Address mappings that are not shown in [Table 367](#) are reserved.

Table 367. Address mapping

14	12	11:9	8:7	Description
16 bit external bus address mapping (Row, Bank, Column)				
0	0	000	00	16 Mb (2Mx8), 2 banks, row length = 11, column length = 9
0	0	000	01	16 Mb (1Mx16), 2 banks, row length = 11, column length = 8
0	0	001	00	64 Mb (8Mx8), 4 banks, row length = 12, column length = 9
0	0	001	01	64 Mb (4Mx16), 4 banks, row length = 12, column length = 8
0	0	010	00	128 Mb (16Mx8), 4 banks, row length = 12, column length = 10
0	0	010	01	128 Mb (8Mx16), 4 banks, row length = 12, column length = 9
0	0	011	00	256 Mb (32Mx8), 4 banks, row length = 13, column length = 10
0	0	011	01	256 Mb (16Mx16), 4 banks, row length = 13, column length = 9
0	0	100	00	512 Mb (64Mx8), 4 banks, row length = 13, column length = 11
0	0	100	01	512 Mb (32Mx16), 4 banks, row length = 13, column length = 10
16 bit external bus address mapping (Bank, Row, Column)				
0	1	000	00	16 Mb (2Mx8), 2 banks, row length = 11, column length = 9
0	1	000	01	16 Mb (1Mx16), 2 banks, row length = 11, column length = 8
0	1	001	00	64 Mb (8Mx8), 4 banks, row length = 12, column length = 9
0	1	001	01	64 Mb (4Mx16), 4 banks, row length = 12, column length = 8
0	1	010	00	128 Mb (16Mx8), 4 banks, row length = 12, column length = 10
0	1	010	01	128 Mb (8Mx16), 4 banks, row length = 12, column length = 9
0	1	011	00	256 Mb (32Mx8), 4 banks, row length = 13, column length = 10
0	1	011	01	256 Mb (16Mx16), 4 banks, row length = 13, column length = 9
0	1	100	00	512 Mb (64Mx8), 4 banks, row length = 13, column length = 11
0	1	100	01	512 Mb (32Mx16), 4 banks, row length = 13, column length = 10
32 bit external bus address mapping (Row, Bank, Column)				
1	0	000	00	16 Mb (2Mx8), 2 banks, row length = 11, column length = 9
1	0	000	01	16 Mb (1Mx16), 2 banks, row length = 11, column length = 8
1	0	001	00	64 Mb (8Mx8), 4 banks, row length = 12, column length = 9
1	0	001	01	64 Mb (4Mx16), 4 banks, row length = 12, column length = 8
1	0	001	10	64 Mb (2Mx32), 4 banks, row length = 11, column length = 8
1	0	010	00	128 Mb (16Mx8), 4 banks, row length = 12, column length = 10
1	0	010	01	128 Mb (8Mx16), 4 banks, row length = 12, column length = 9
1	0	010	10	128 Mb (4Mx32), 4 banks, row length = 12, column length = 8
1	0	011	00	256 Mb (32Mx8), 4 banks, row length = 13, column length = 10
1	0	011	01	256 Mb (16Mx16), 4 banks, row length = 13, column length = 9
1	0	011	10	256 Mb (8Mx32), 4 banks, row length = 13, column length = 8
1	0	100	00	512 Mb (64Mx8), 4 banks, row length = 13, column length = 11
1	0	100	01	512 Mb (32Mx16), 4 banks, row length = 13, column length = 10
1	0	010	01	256 Mb (8Mx32), 4 banks, row length = 12, column length = 9
1	0	011	01	512 Mb, (16Mx32), 4 banks, row length = 13, column length = 9
1	0	100	01	1 Gb (32Mx32), 4 banks, row length = 13, column length = 10
32 bit external bus address mapping (Bank, Row, Column)				
1	1	000	00	16 Mb (2Mx8), 2 banks, row length = 11, column length = 9

Table 367. Address mapping

14	12	11:9	8:7	Description
1	1	000	01	16 Mb (1Mx16), 2 banks, row length = 11, column length = 8
1	1	001	00	64 Mb (8Mx8), 4 banks, row length = 12, column length = 9
1	1	001	01	64 Mb (4Mx16), 4 banks, row length = 12, column length = 8
1	1	001	10	64 Mb (2Mx32), 4 banks, row length = 11, column length = 8
1	1	010	00	128 Mb (16Mx8), 4 banks, row length = 12, column length = 10
1	1	010	01	128 Mb (8Mx16), 4 banks, row length = 12, column length = 9
1	1	010	10	128 Mb (4Mx32), 4 banks, row length = 12, column length = 8
1	1	011	00	256 Mb (32Mx8), 4 banks, row length = 13, column length = 10
1	1	011	01	256 Mb (16Mx16), 4 banks, row length = 13, column length = 9
1	1	011	10	256 Mb (8Mx32), 4 banks, row length = 13, column length = 8
1	1	100	00	512 Mb (64Mx8), 4 banks, row length = 13, column length = 11
1	1	100	01	512 Mb (32Mx16), 4 banks, row length = 13, column length = 10
1	1	010	01	256 Mb (8Mx32), 4 banks, row length = 12, column length = 9
1	1	011	01	512 Mb, (16Mx32), 4 banks, row length = 13, column length = 9
1	1	100	01	1 Gb (32Mx32), 4 banks, row length = 13, column length = 10

A chip select can be connected to a single memory device, in this case the chip select data bus width is the same as the device width. Alternatively the chip select can be connected to a number of external devices. In this case the chip select data bus width is the sum of the memory device data bus widths.

For example, for a chip select connected to:

- a 32-bit wide memory device, choose a 32-bit wide address mapping.
- a 16-bit wide memory device, choose a 16-bit wide address mapping.
- four x 8-bit wide memory devices, choose a 32-bit wide address mapping.
- two x 8-bit wide memory devices, choose a 16-bit wide address mapping.

The SDRAM bank select pins BA1 and BA0 are connected to address lines A14 and A13, respectively.

22.6.20 Dynamic Memory RAS/CAS Delay registers

These registers enable you to program the RAS and CAS latencies for the relevant dynamic memory. It is recommended that these registers are modified during system initialization, or when there are no current or outstanding transactions. This can be ensured by waiting until the EMC is idle, and then entering low-power, or disabled mode. These registers are accessed with one wait state.

Note: The values programmed into these registers must be consistent with the values used to initialize the SDRAM memory device.

Table 368. Dynamic Memory RASCAS Delay registers (DYNAMICRASCAS[0:3], address 0x4000 5104 (DYNAMICRASCAS0), 0x4000 5124 (DYNAMICRASCAS1), 0x4000 5144 (DYNAMICRASCAS2), 0x4000 5164 (DYNAMICRASCAS3)) bit description

Bit	Symbol	Value	Description	Reset value
1:0	RAS		RAS latency (active to read/write delay).	11
		0x0	Reserved.	
		0x1	One EMC_CCLK cycle.	
		0x2	Two EMC_CCLK cycles.	
		0x3	Three EMC_CCLK cycles (POR reset value).	
7:2	-	-	Reserved, user software should not write ones to reserved bits. The value read from a reserved bit is not defined.	-
9:8	CAS		CAS latency.	11
		0x0	Reserved.	
		0x1	One EMC_CCLK cycle.	
		0x2	Two EMC_CCLK cycles.	
		0x3	Three EMC_CCLK cycles (POR reset value).	
31:10	-	-	Reserved, user software should not write ones to reserved bits. The value read from a reserved bit is not defined.	-

22.6.21 Static Memory Configuration registers

These registers configure the static memory configuration. It is recommended that these registers are modified during system initialization, or when there are no current or outstanding transactions. This can be ensured by waiting until the EMC is idle, and then entering low-power, or disabled mode. These registers are accessed with one wait state.

Table 369. Static Memory Configuration registers (STATICCONFIG[0:3], address 0x4000 5200 (STATICCONFIG0), 0x4000 5220 (STATICCONFIG1), 0x4000 5240 (STATICCONFIG2), 0x4000 5260 (STATICCONFIG3)) bit description

Bit	Symbol	Value	Description	Reset value
1:0	MW		Memory width.	0
		0x0	8 bit (POR reset value).	
		0x1	16 bit.	
		0x2	32 bit.	
		0x3	Reserved.	
2	-	-	Reserved, user software should not write ones to reserved bits. The value read from a reserved bit is not defined.	-

Table 369. Static Memory Configuration registers (STATICCONFIG[0:3], address 0x4000 5200 (STATICCONFIG0), 0x4000 5220 (STATICCONFIG1), 0x4000 5240 (STATICCONFIG2), 0x4000 5260 (STATICCONFIG3)) bit description

Bit	Symbol	Value	Description	Reset value
3	PM		Page mode. In page mode the EMC can burst up to four external accesses. Therefore devices with asynchronous page mode burst four or higher devices are supported. Asynchronous page mode burst two devices are not supported and must be accessed normally.	0
		0	Disabled (POR reset value).	
		1	Async page mode enabled (page length four).	
5:4	-	-	Reserved, user software should not write ones to reserved bits. The value read from a reserved bit is not defined.	-
6	PC		Chip select polarity. The value of the chip select polarity on power-on reset is 0.	0
		0	Active LOW chip select.	
		1	Active HIGH chip select.	
7	PB		Byte lane state. The byte lane state bit, PB, enables different types of memory to be connected. For byte-wide static memories the BLSn[3:0] signal from the EMC is usually connected to WE (write enable). In this case for reads all the BLSn[3:0] bits must be HIGH. This means that the byte lane state (PB) bit must be LOW. 16 bit wide static memory devices usually have the BLSn[3:0] signals connected to the UBn and LBn (upper byte and lower byte) signals in the static memory. In this case a write to a particular byte must assert the appropriate UBn or LBn signal LOW. For reads, all the UB and LB signals must be asserted LOW so that the bus is driven. In this case the byte lane state (PB) bit must be HIGH. Remark: When PB is set to 0, the WE signal is undefined or 0. You must set PB to 1, to use the WE signal.	0
		0	For reads all the bits in BLSn[3:0] are HIGH. For writes the respective active bits in BLSn[3:0] are LOW (POR reset value).	
		1	For reads the respective active bits in BLSn[3:0] are LOW. For writes the respective active bits in BLSn[3:0] are LOW.	
8	EW		Extended wait. Extended wait (EW) uses the StaticExtendedWait register to time both the read and write transfers rather than the StaticWaitRd and StaticWaitWr registers. This enables much longer transactions. [1]	0
		0	Extended wait disabled (POR reset value).	
		1	Extended wait enabled.	
18:9	-	-	Reserved, user software should not write ones to reserved bits. The value read from a reserved bit is not defined.	-
19	B		Buffer enable [2] .	0
		0	Buffer disabled (POR reset value).	
		1	Buffer enabled.	

Table 369. Static Memory Configuration registers (STATICCONFIG[0:3], address 0x4000 5200 (STATICCONFIG0), 0x4000 5220 (STATICCONFIG1), 0x4000 5240 (STATICCONFIG2), 0x4000 5260 (STATICCONFIG3)) bit description

Bit	Symbol	Value	Description	Reset value
20	P		Write protect.	0
		0	Writes not protected (POR reset value).	
		1	Write protected.	
31:21	-	-	Reserved, user software should not write ones to reserved bits. The value read from a reserved bit is not defined.	-

[1] Extended wait and page mode cannot be selected simultaneously.

[2] EMC may perform burst read access even when the buffer enable bit is cleared.

22.6.22 Static Memory Write Enable Delay registers

These registers enable you to program the delay from the chip select to the write enable. It is recommended that these registers are modified during system initialization, or when there are no current or outstanding transactions. This can be ensured by waiting until the EMC is idle, and then entering low-power, or disabled mode. These registers are accessed with one wait state.

Table 370. Static Memory Write Enable Delay registers (STATICWAITWEN[0:3], address 0x4000 5204 (STATICWAITWEN0), 0x4000 5224 (STATICWAITWEN1), 0x4000 5244 (STATICWAITWEN2), 0x4000 5264 (STATICWAITWEN3)) bit description

Bit	Symbol	Description	Reset value
3:0	WAITWEN	Wait write enable. Delay from chip select assertion to write enable. 0x0 = One EMC_CCLK cycle delay between assertion of chip select and write enable (POR reset value). 0x1 - 0xF = (n + 1) EMC_CCLK cycle delay. The delay is (WAITWEN + 1) x tEMC_CCLK.	0x0
31:4	-	Reserved, user software should not write ones to reserved bits. The value read from a reserved bit is not defined.	-

22.6.23 Static Memory Output Enable Delay registers

These registers enable you to program the delay from the chip select or address change, whichever is later, to the output enable. It is recommended that these registers are modified during system initialization, or when there are no current or outstanding transactions. This can be ensured by waiting until the EMC is idle, and then entering low-power, or disabled mode. These registers are accessed with one wait state.

Table 371. Static Memory Output Enable delay registers (STATICWAITOEN[0:3], address 0x4000 5208 (STATICWAITOEN0), 0x4000 5228 (STATICWAITOEN1), 0x4000 5248 (STATICWAITOEN2), 0x4000 5268 (STATICWAITOEN3)) bit description

Bit	Symbol	Description	Reset value
3:0	WAITOEN	Wait output enable. Delay from chip select assertion to output enable. 0x0 = No delay (POR reset value). 0x1 - 0xF = n cycle delay. The delay is WAITOEN x tEMC_CCLK.	0x0
31:4	-	Reserved, user software should not write ones to reserved bits. The value read from a reserved bit is not defined.	-

22.6.24 Static Memory Read Delay registers

These registers enable you to program the delay from the chip select to the read access. It is recommended that these registers are modified during system initialization, or when there are no current or outstanding transactions. This can be ensured by waiting until the EMC is idle, and then entering low-power, or disabled mode. It is not used if the extended wait bit is enabled in the StaticConfig registers. These registers are accessed with one wait state.

Table 372. Static Memory Read Delay registers (STATICWAITRD[0:3], address 0x4000 520C (STATICWAITRD0), 0x4000 522C (STATICWAITRD1), 0x4000 524C (STATICWAITRD2), 0x4000 526C (STATICWAITRD3)) bit description

Bit	Symbol	Description	Reset value
4:0	WAITRD	Non-page mode read wait states or asynchronous page mode read first access wait state. Non-page mode read or asynchronous page mode read, first read only: 0x0 - 0x1E = (n + 1) EMC_CCLK cycles for read accesses. For non-sequential reads, the wait state time is (WAITRD + 1) x tEMC_CCLK. 0x1F = 32 EMC_CCLK cycles for read accesses (POR reset value).	0x1F [1]
31:5	-	Reserved, user software should not write ones to reserved bits. The value read from a reserved bit is not defined.	-

[1] The reset value depends on the boot mode. See [Section 4.3.6.2 "EMC boot mode"](#).

22.6.25 Static Memory Page Mode Read Delay registers

These registers enable you to program the delay for asynchronous page mode sequential accesses. It is recommended that these registers are modified during system initialization, or when there are no current or outstanding transactions. This can be ensured by waiting until the EMC is idle, and then entering low-power, or disabled mode. This register is accessed with one wait state.

Table 373. Static Memory Page Mode Read Delay registers (STATICWAITPAGE[0:3], address 0x4000 5210 (STATICWAITPAGE0), 0x4000 5230 (STATICWAITPAGE1), 0x4000 5250 (STATICWAITPAGE2), 0x4000 5270 (STATICWAITPAGE3)) bit description

Bit	Symbol	Description	Reset value
4:0	WAITPAGE	Asynchronous page mode read after the first read wait states. Number of wait states for asynchronous page mode read accesses after the first read: 0x0 - 0x1E = (n + 1) EMC_CCLK cycle read access time. For asynchronous page mode read for sequential reads, the wait state time for page mode accesses after the first read is (WAITPAGE + 1) x tEMC_CCLK. 0x1F = 32 EMC_CCLK cycle read access time (POR reset value).	0x1F
31:5	-	Reserved, user software should not write ones to reserved bits. The value read from a reserved bit is not defined.	-

22.6.26 Static Memory Write Delay registers

These registers enable you to program the delay from the chip select to the write access. It is recommended that these registers are modified during system initialization, or when there are no current or outstanding transactions. This can be ensured by waiting until the EMC is idle, and then entering low-power, or disabled mode. These registers are not used if the extended wait (EW) bit is enabled in the StaticConfig register. These registers are accessed with one wait state.

Table 374. Static Memory Write Delay registers (STATICWAITWR[0:3], address 0x4000 5214 (STATICWAITWR0), 0x4000 5234 (STATICWAITWR1), 0x4000 5254 (STATICWAITWR2), 0x4000 5274 (STATICWAITWR3)) bit description

Bit	Symbol	Description	Reset value
4:0	WAITWR	Write wait states. SRAM wait state time for write accesses after the first read: 0x0 - 0x1E = (n + 2) EMC_CCLK cycle write access time. The wait state time for write accesses after the first read is WAITWR (n + 2) x tEMC_CCLK. 0x1F = 33 EMC_CCLK cycle write access time (POR reset value).	0x1F
31:5	-	Reserved, user software should not write ones to reserved bits. The value read from a reserved bit is not defined.	-

22.6.27 Static Memory Turn-around Delay registers

These registers enable you to program the number of bus turn-around cycles. It is recommended that these registers are modified during system initialization, or when there are no current or outstanding transactions. This can be ensured by waiting until the EMC is idle, and then entering low-power, or disabled mode. These registers are accessed with one wait state.

Table 375. Static Memory Turn-around Delay registers (STATICWAITTURN[0:3], address 0x4000 5218 (STATICWAITTURN0), 0x4000 5238 (STATICWAITTURN1), 0x4000 5258 (STATICWAITTURN2), 0x4000 5278 (STATICWAITTURN3)) bit description

Bit	Symbol	Description	Reset value
3:0	WAITTURN	Bus turn-around cycles. 0x0 - 0xE = (n + 1) EMC_CCLK turn-around cycles. Bus turn-around time is (WAITTURN + 1) x tEMC_CCLK. 0xF = 16 EMC_CCLK turn-around cycles (POR reset value).	0xF
31:4	-	Reserved, user software should not write ones to reserved bits. The value read from a reserved bit is not defined.	-

Bus turn-around cycles are generated between external bus transfers in the following situations when at least one of the memory banks is static memory:

- between read and read to different memory banks
- between read and write to the same memory bank
- between read and write to different memory banks

Bus turn-around cycles prevent bus contention on the external memory data bus.

22.7 Functional description

[Figure 49](#) shows a block diagram of the EMC.

The functions of the EMC blocks are described in the following sections:

- AHB slave register interface.
- AHB slave memory interfaces.
- Data buffers.
- Memory controller state machine.
- Pad interface.

22.7.1 AHB slave register interface

The AHB slave register interface block enables the registers of the EMC to be programmed. This module also contains most of the registers and performs the majority of the register address decoding.

To eliminate the possibility of endianness problems, all data transfers to and from the registers of the EMC must be 32 bits wide.

Note: If an access is attempted with a size other than a word (32 bits), it causes an ERROR response to the AHB bus and the transfer is terminated.

22.7.2 AHB slave memory interface

The AHB slave memory interface allows access to external memories.

22.7.2.1 Memory transaction endianness

The endianness of the data transfers to and from the external memories is determined by the Endian mode (N) bit in the Config register.

Note: The memory controller must be idle (see the busy field of the Status Register) before endianness is changed, so that the data is transferred correctly.

22.7.2.2 Memory transaction size

Memory transactions can be 8, 16, or 32 bits wide. Any access attempted with a size greater than a word (32 bits) causes an ERROR response to the AHB bus and the transfer is terminated.

22.7.2.3 Write protected memory areas

Write transactions to write-protected memory areas generate an ERROR response to the AHB bus and the transfer is terminated.

22.7.3 Pad interface

The pad interface block provides the interface to the pads.

The EMC dynamic memory interface requires that all EMC_CLK signals are selected on the CLKn pins for 16-bit memory and for 32-bit memory.

For static memory larger delays are defined by in steps of one EMC clock cycle by the STATICWAIT registers (see [Section 22.6.22](#) to [Section 22.6.27](#)).

22.7.4 Data buffers

The AHB interface reads and writes via buffers to improve memory bandwidth and reduce transaction latency. The EMC contains four 16-word buffers. The buffers can be used as read buffers, write buffers, or a combination of both. The buffers are allocated automatically.

The buffers must be disabled during SDRAM initialization. The buffers must be enabled during normal operation.

The buffers can be enabled or disabled for static memory using the StaticConfig Registers.

22.7.4.1 Write buffers

Write buffers are used to:

- Merge write transactions so that the number of external transactions are minimized. Buffer data until the EMC can complete the write transaction, improving AHB write latency.
Convert all dynamic memory write transactions into quadword bursts on the external memory interface. This enhances transfer efficiency for dynamic memory.
- Reduce external memory traffic. This improves memory bandwidth and reduces power consumption.

Write buffer operation:

- If the buffers are enabled, an AHB write operation writes into the Least Recently Used (LRU) buffer, if empty.
If the LRU buffer is not empty, the contents of the buffer are flushed to memory to make space for the AHB write data.
- If a buffer contains write data it is marked as dirty, and its contents are written to memory before the buffer can be reallocated.

The write buffers are flushed whenever:

- The memory controller state machine is not busy performing accesses to external memory.
The memory controller state machine is not busy performing accesses to external memory, and an AHB interface is writing to a different buffer.

Note: For dynamic memory, the smallest buffer flush is a quadword of data. For static memory, the smallest buffer flush is a byte of data.

22.7.4.2 Read buffers

Read buffers are used to:

- Buffer read requests from memory. Future read requests that hit the buffer read the data from the buffer rather than memory, reducing transaction latency.

Convert all read transactions into quadword bursts on the external memory interface. This enhances transfer efficiency for dynamic memory.

- Reduce external memory traffic. This improves memory bandwidth and reduces power consumption.

Read buffer operation:

- If the buffers are enabled and the read data is contained in one of the buffers, the read data is provided directly from the buffer.
- If the read data is not contained in a buffer, the LRU buffer is selected. If the buffer is dirty (contains write data), the write data is flushed to memory. When an empty buffer is available the read command is posted to the memory.

A buffer filled by performing a read from memory is marked as not-dirty (not containing write data) and its contents are not flushed back to the memory controller unless a subsequent AHB transfer performs a write that hits the buffer.

22.7.5 Using the EMC with SDRAM

22.7.5.1 SDRAM burst length

For 32-bit wide chip selects data is transferred to and from dynamic memory in SDRAM bursts of four. For 16-bit wide chip selects SDRAM bursts of eight are used.

22.7.5.2 SDRAM mode register burst length set-up

To be used with the EMC, the SDRAM must be configured for a 128-bit sequential burst. The burst length is configured through the mode register in the SDRAM memory. The layout for a JEDEC standard SDRAM mode register is shown in [Table 376](#). The EMC address bits are mapped to the SDRAM mode register bits as indicated in [Table 376](#).

Table 376. SDRAM mode register description

Address line	SDRAM mode register bit	Value	Description
A2:A0	2:0		Burst length
		000	1 (M3 = 0) 1 (M3 = 1)
		001	2 (M3 = 0) 2 (M3 = 1)
		010	4 (M3 = 0) 4 (M3 = 1)
		011	8 (M3 = 0) 8 (M3 = 1)
		100	Reserved (M3 = 0) Reserved (M3 = 1)
		101	Reserved (M3 = 0) Reserved (M3 = 1)
		110	Reserved (M3 = 0) Reserved (M3 = 1)
		111	Full page (M3 = 0) Reserved (M3 = 1)

Table 376. SDRAM mode register description

Address line	SDRAM mode register bit	Value	Description
A3	3		Burst type
		0	Sequential
		1	Interleaved
A6:A4	6:4		Latency mode
		000	Reserved
		001	Reserved
		010	2
		011	3
		100	Reserved
		101	Reserved
		110	Reserved
		111	Reserved
		A8:A7	8:7
00	Standard operation		
A9	9		Write burst mode
		0	Programmed burst length
		1	Single location access
A11:A10	11:10		Reserved

The SDRAM mode register is loaded in two steps:

1. Use the DYNAMICCONTROL register to issue a set mode command.
2. When the SDRAM is in the set mode state, issue an SDRAM read from an address specific to the selected mode and the SDRAM memory organization.

This loads the mode register with the correct settings.

The read address is calculated as follows:

- Determine the mode register content MODE:
 - For a single 16-bit external SDRAM chip set the burst length to 8. For a single 32-bit SDRAM chip set the burst length to 4.
 - Select the sequential mode.
 - Select latency mode = 2 or 3.
 - Select Write burst mode = 0.
- Determine the shift value OFFSET to shift the mode register content by. This shift value depends on the SDRAM device organization and it is calculated as:
 - OFFSET = number of columns + total bus width + bank select bits (RBC mode)
 - OFFSET = number of columns + total bus width (BRC mode)
 - The number of columns is listed in [Table 367](#) for a specific SDRAM device.
 - The total bus width is 1 for a 16-bit bus and 2 for a 32-bit bus. If you combine two 16-bit devices to form a 32-bit memory bank, the total bus width is 2.

- This is the number of bits needed to indicate the number of banks. Most SDRAM devices use 2 bank select bits for four banks.
- Select the SDRAM memory mapped address DYCSX.
- The SDRAM read address is $ADDRESS = DYCSX + (MODE \ll OFFSET)$.

22.7.5.2.1 Example for setting the SDRAM mode register

For a 16-bit external SDRAM chip, select latency mode = 2 and burst size = 8. The mode register value is $MODE = 0x23$.

Using a 128 Mb (8Mx16) SDRAM chip with address mapping of 4 banks, row length = 12, column length = 9 (see [Table 367](#)), $OFFSET = 9 + 1 + 2$.

Using DYCS0, the SDRAM address is 0x2800 0000.

The SDRAM read command address becomes 0x2802 3000.

22.7.5.3 Self-refresh mode

The EMC provides a mechanism to place the dynamic memories into self-refresh mode.

Self-refresh mode can be entered by software by setting the SR bit in the DynamicControl Register and polling the SA bit in the Status Register.

Any transactions to memory that are generated while the memory controller is in self-refresh mode are rejected and an error response is generated to the AHB bus. Clearing the SR bit in the DynamicControl Register returns the memory to normal operation. See the memory data sheet for refresh requirements.

Note: The static memory can be accessed as normal when the SDRAM memory is in self-refresh mode.

22.7.6 External static memory interface

External memory interfacing depends on the bank width (32, 16 or 8 bit selected via MW bits in corresponding StaticConfig register).

If a memory bank is configured to be 32 bits wide, address lines A0 and A1 can be used as non-address lines. If a memory bank is configured to 16 bits wide, A0 is not required. However, 8 bit wide memory banks do require all address lines down to A0. Configuring A1 and/or A0 lines to provide address or non-address function is accomplished using the SYSCON registers.

Symbol a_b in the following figures refers to the highest order address line in the data bus. Symbol a_m refers to the highest order address line of the memory chip used in the external memory interface.

If the external memory is used as external boot memory for flashless devices, refer to [Section 4.2](#) on how to connect the EMC. The memory bank width for memory banks one and two is determined by the setting of the BOOT pins.

22.7.6.1 32 bit wide memory bank connection

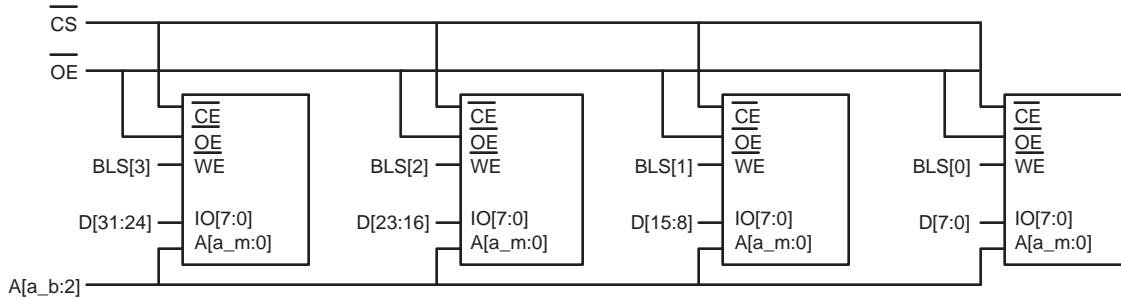

a. 32 bit wide memory bank interfaced to four 8 bit memory chips

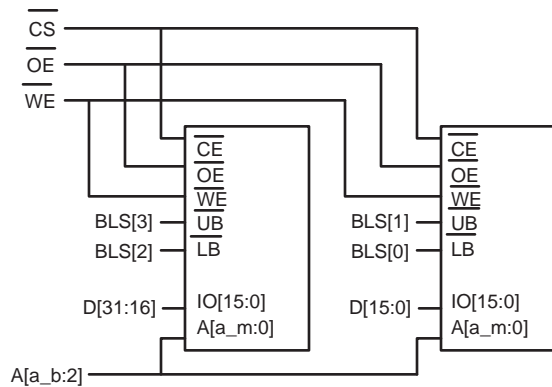

b. 32 bit wide memory bank interfaced to two 16 bit memory chips

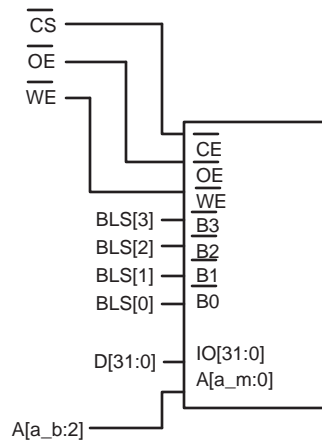

c. 32 bit wide memory bank interfaced to one 8 bit memory chip

Fig 51. 32 bit bank external memory interfaces (bits MW = 10)

22.7.6.2 16 bit wide memory bank connection

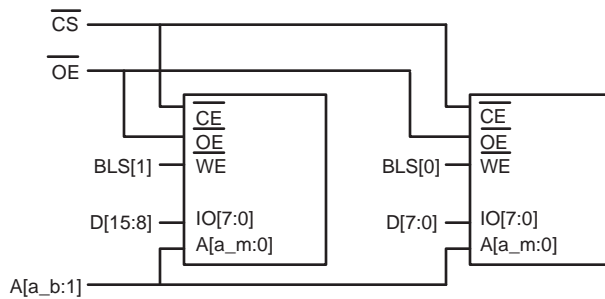

a. 16 bit wide memory bank interfaced to two 8 bit memory chips

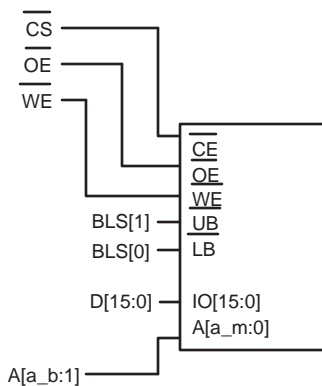

b. 16 bit wide memory bank interfaced to a 16 bit memory chip

Fig 52. 16 bit bank external memory interfaces (bits MW = 01)

22.7.6.3 8 bit wide memory bank connection

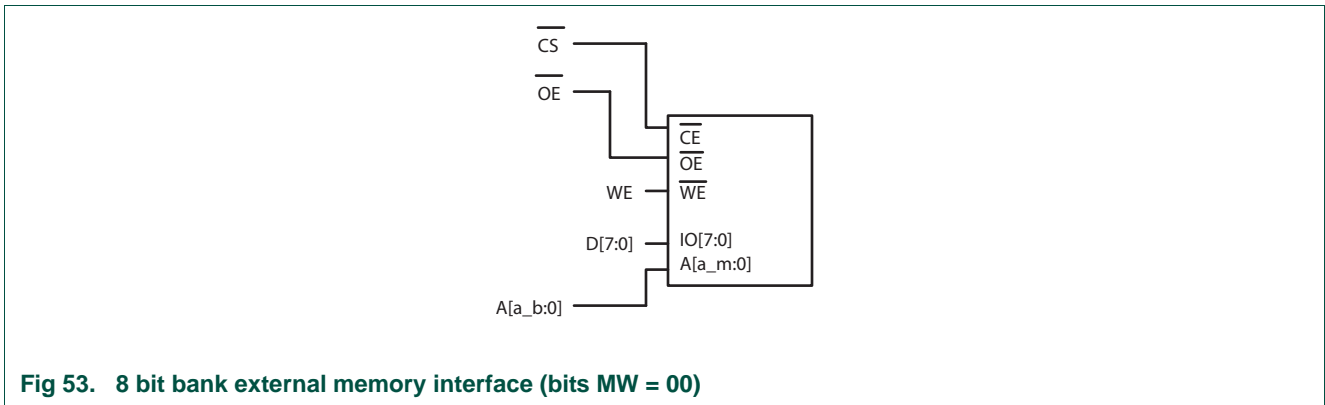

23.1 How to read this chapter

The USB0 Host/Device/OTG controller is available on parts LPC185x, LPC183x and LPC182x.

USB frame length adjustment is available for parts with on-chip flash only.

23.2 Basic configuration

The USB0 Host/Device/OTG controller is configured as follows:

- See [Table 377](#) for clocking and power control.
- The USB0 is reset by the USB0_RST (reset # 17).
- The USB0 OTG interrupt is connected to interrupt slot # 8 in the NVIC, and the wake-up request indicator is connected to slot # 9 in the Event router (see [Section 23.12.4](#)).
- Power to the USB0 on-chip PHY is controlled through the CREG block (see [Table 88](#)). The on-chip PHY is powered down by default unless the USB0 boot mode is selected. To use the USB0 controller, enable the PHY in the CREG0 register, bit 5.
- The SOF/VF indicator can be connected to Timer3 or the to SCT through the GIMA (see [Section 23.7.7](#) and [Table 190](#)).
- The registers for frame length adjustment in USB host mode are located in the CREG block (see [Table 98](#); parts with on-chip flash only).

Table 377. USB0 clocking and power control

	Base clock	Branch clock	Operating frequency	Notes
USB0 clock	BASE_USB0_CLK	CLK_USB0	480 MHz	Uses PLL0USB dedicated to USB0. CLK_USB0 must be set to the 480 MHz clock in all USB modes (low-speed, full-speed, and high-speed modes).
USB0 register interface clock	BASE_M3_CLK	CLK_M3_USB0	up to 180 MHz	-

23.3 Features

- Contains on-chip high-speed UTMI+ compliant transceiver (PHY).
- Supports all high-speed, full-speed, and low-speed USB-compliant peripherals.
- Complies with Universal Serial Bus specification 2.0.
- Complies with USB On-The-Go supplement.
- Complies with Enhanced Host Controller Interface (EHCI) Specification.
- Supports auto USB 2.0 mode discovery.

- Supports software HNP and SRP for OTG peripherals.
- Supports power management.
- Supports six logical endpoints including one control endpoint for a total of 12 physical endpoints.
- This module has its own, integrated DMA engine.
- Can be used together with the audio PLL for USB streaming applications.
- Support for frame length adjustment to correlate the SOF signal with an external clock (see [Section 23.7.7.1](#)).

23.4 Introduction

Universal Serial Bus (USB) is a standard protocol developed to connect several types of devices to each other in order to exchange data or for other purposes. Many portable devices can benefit from the ability to communicate to each other over the USB interface without intervention of a host PC. The addition of the On-The-Go functionality to USB makes this possible without losing the benefits of the standard USB protocol. Examples of USB devices are: PC, mouse, keyboard, MP3 player, digital camera, USB storage device (USB stick).

23.4.1 Block diagram

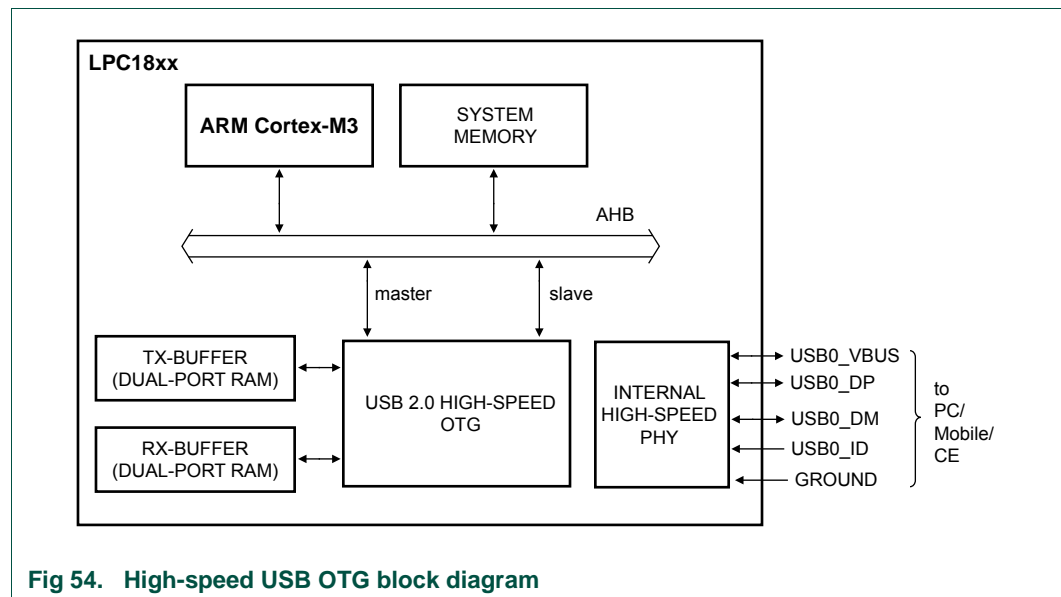

Fig 54. High-speed USB OTG block diagram

23.4.2 About USB On-The-Go

The USB On-The-Go block enables usage in both device mode and in host mode. This means that you can connect to a PC to exchange data, but also to another USB device such as a digital camera or MP3 player.

23.4.3 USB acronyms and abbreviations

Table 378. USB related acronyms

Acronym	Description
ATX	Analog Transceiver
DCD	Device Controller Driver
dQH	device Endpoint Queue Head
dTD	device Transfer Descriptor
EOP	End Of Packet
EP	End Point
FS	Full Speed
HCD	Host Controller Driver
HS	High Speed
LS	Low Speed
MPS	Maximum Packet Size
NAK	Negative Acknowledge
OTG	On-The-Go
PID	Packet Identifier
QH	Queue Head
SE0	Single Ended 0
SOF	Start Of Frame
TT	Transaction Translator
USB	Universal Serial Bus

23.4.4 Transmit and receive buffers

The USB OTG controller contains a Transmit buffer to store data to be transmitted on the USB and a Receive buffer to store data received from the USB. The Receive buffer contains 256 words. The Transmit buffer contains 128 words for each endpoint in device mode and 512 words in host mode.

23.4.5 Fixed endpoint configuration

[Table 379](#) shows the supported endpoint configurations. The Maximum Packet Size (see [Table 380](#)) is dependent on the type of endpoint and the device configuration (low-speed, full-speed, or high-speed).

Table 379. Fixed endpoint configuration

Logical endpoint	Physical endpoint	Endpoint type	Direction
0	0	Control	Out
0	1	Control	In
1	2	Interrupt/Bulk/Isochronous	Out
1	3	Interrupt/Bulk/Isochronous	In
2	4	Interrupt/Bulk/Isochronous	Out
2	5	Interrupt/Bulk/Isochronous	In
3	6	Interrupt/Bulk/Isochronous	Out

Table 379. Fixed endpoint configuration

Logical endpoint	Physical endpoint	Endpoint type	Direction
3	7	Interrupt/Bulk/Isochronous	In
4	8	Interrupt/Bulk/Isochronous	Out
4	9	Interrupt/Bulk/Isochronous	In
5	10	Interrupt/Bulk/Isochronous	Out
5	11	Interrupt/Bulk/Isochronous	In

Table 380. USB Packet size

Endpoint type	Speed	Packet size (byte)
Control	Low-speed	8
	Full-speed	8, 16, 32, or 64
	High-speed	64
Isochronous	Low-speed	n/a
	Full-speed	up to 1023
	High-speed	up to 1024
Interrupt	Low-speed	up to 8
	Full-speed	up to 64
	High-speed	up to 1024
Bulk	Low-speed	n/a
	Full-speed	8, 16, 32, or 64
	High-speed	8, 16, 32, 64 or 512

23.5 Pin description

Table 381. USB0 pin description

Pin function	Direction	Description
USB0_IND0	O	Port indicator LED control output.
USB0_IND1	O	Port indicator LED control output.
USB0_PWR_FAULT	I	Port power fault signal indicating overcurrent condition; this signal monitors over-current on the USB bus (external circuitry required to detect over-current condition).
USB0_PPWR	O	VBUS drive signal (towards external charge pump or power management unit); indicates that VBUS must be driven (active HIGH). Add a pull-down resistor to disable the power switch at reset. This signal has opposite polarity compared to the USB_PPWR used on other NXP LPC parts.
USB0_DP	I/O	USB0 bidirectional D+ line. The D+ line has an internal 1.5 kΩ pull-up. This pull-up is enabled when software sets the RS bit (Bit 0) in the USBCMD register and the USB0 controller sees a valid VBUS voltage level (above ~1.8V) on the VBUS pin. Do not add an external series resistor.
USB0_DM	I/O	USB0 bidirectional D– line. Do not add an external series resistor.

Table 381. USB0 pin description

Pin function	Direction	Description
USB0_VBUS	I	VBUS pin (power on USB cable). This pin includes an internal pull-down resistor of 64 kOhm (typical) \pm 16 kOhm. For maximum load $C_L = 6.5 \mu\text{F}$ and maximum pull-down resistor $R_{pd} = 80 \text{ kOhm}$, the VBUS signal takes about 2 s to fall from $\text{VBUS} = 5 \text{ V}$ to $\text{VBUS} = 0.2 \text{ V}$ when it is no longer driven. Remark: This input is only 5 V tolerant when VDDIO is present. See Section 23.5.1 .
USB0_ID	I	Indicates to the transceiver whether connected as an A-device (USB0_ID LOW) or B-device (USB0_ID HIGH). For OTG this pin has an internal pull-up resistor.
USB0_RREF		12.0 k Ω (accuracy 1%) on-board resistor to ground for current reference;
USB0_VDDA3V3_DRIVER		Separate analog 3.3 V power supply for driver.
USB0_VDDA3V3		USB 3.3 V separate power supply voltage
USB0_VSSA_TERM		Dedicated analog ground for clean reference for termination resistors.
USB0_VSSA_REF		Dedicated clean analog ground for generation of reference currents and voltages.

23.5.1 Requirements for connecting the USB0_VBUS/USB1_VBUS signal

The USB0_VBUS and USB1_VBUS pins are only 5 V tolerant when VDDIO is present. Therefore, special precautions are necessary when the USB0 controller is implemented as a USB-powered USB device or an OTG product.

For a USB OTG product, it is important to be able to detect the VBUS level and to charge and discharge VBUS. This requires adding active devices that disconnect the link when VDDIO is not present.

For self-powered USB products that only use USB0 and that do not run in OTG mode, USB0_VBUS can be left disconnected as long as the VC bit in the OTGSC register is set. When this bit is set, a voltage is applied to the USB0_VBUS pin internally which is the equivalent of connecting the pin to a 5 V VBUS supply. Keeping the USB0_VBUS disconnected, ensures that OTG VBUS line pulsing does not go towards the cable.

23.6 Register description

Table 382. Register access abbreviations

Abbreviation	Description
R/W	Read/Write
R/WC	Read/Write one to Clear
R/WO	Read/Write Once
RO	Read Only
WO	Write Only
R/WS	Read/Write one to Set

Table 383. Register overview: USB0 OTG controller (register base address 0x4000 6000)

Name	Access	Address offset	Description	Reset value	Reset value after USB0 boot	Reference
-	-	0x000 - 0x0FF	Reserved	-	-	-
Device/host capability registers						
SBUSCFG	R/W	0x90	System bus interface configuration	0	0	Table 384
CAPLENGTH	RO	0x100	Capability register length	0x01000040	0x01000040	Table 385
HCSPARAMS	RO	0x104	Host controller structural parameters	0x00010011	0x00010011	Table 386
HCCPARAMS	RO	0x108	Host controller capability parameters	0x00000006	0x00000006	Table 387
DCIVERSION	RO	0x120	Device interface version number	0x00000001	0x00000001	Table 388
DCCPARAMS	RO	0x124	Device controller capability parameters	0x00000186	0x00000186	Table 389
-	-	0x128 - 0x13C	Reserved	-	-	-
Device/host operational registers						
USBCMD_D	R/W	0x140	USB command (device mode)	0x00080000	0	Table 390
USBCMD_H	R/W	0x140	USB command (host mode)	0x00080000	-	Table 391
USBSTS_D	R/W	0x144	USB status (device mode)	0	0x00000080	Table 393
USBSTS_H	R/W	0x144	USB status (host mode)	0	-	Table 394
USBINTR_D	R/W	0x148	USB interrupt enable (device mode)	0	0x00010147	Table 395
USBINTR_H	R/W	0x148	USB interrupt enable (host mode)	0	-	Table 396
FRINDEX_D	R/W	0x14C	USB frame index (device mode)	0	0x00001F20	Table 397
FRINDEX_H	R/W	0x14C	USB frame index (host mode)	0	-	Table 398
-	-	0x150	Reserved	-	-	-
DEVICEADDR	R/W	0x154	USB device address (device mode)	0	0x04000000	Table 400
PERIODICLISTBASE	R/W	0x154	Frame list base address (host mode)	0	-	Table 401
ENDPOINTLISTADDR	R/W	0x158	Address of endpoint list in memory	0	0x20000000	Table 402
ASYNCLISTADDR	R/W	0x158	Asynchronous list address	0	0	Table 403
TTCTRL	R/W	0x15C	Asynchronous buffer status for embedded TT (host mode)	0	0	Table 404
BURSTSIZE	R/W	0x160	Programmable burst size	0	0	Table 405
TXFILLTUNING	R/W	0x164	Host transmit pre-buffer packet tuning (host mode)	0	0	Table 406
-	-	0x168 - 0x170	Reserved	-	-	-

Table 383. Register overview: USB0 OTG controller (register base address 0x4000 6000) ...continued

Name	Access	Address offset	Description	Reset value	Reset value after USB0 boot	Reference
BINTERVAL	R/W	0x174	Length of virtual frame	0	0	Table 407
ENDPTNAK	R/W	0x178	Endpoint NAK (device mode)	0	0	Table 408
ENDPTNAKEN	R/W	0x17C	Endpoint NAK Enable (device mode)	0	0	Table 409
-	-	0x180	Reserved	-	-	
PORTSC1_D	R/W	0x184	Port 1 status/control (device mode)	0	0x3C000004	Table 410
PORTSC1_H	R/W	0x184	Port 1 status/control (host mode)	0	-	Table 411
-	-	0x188 - 0x1A0		-	-	-
OTGSC	R/W	0x1A4	OTG status and control	0	0x00200D09	Table 413
USBMODE_D	R/W	0x1A8	USB device mode (device mode)	0	0xA	Table 414
USBMODE_H	R/W	0x1A8	USB device mode (host mode)	0	-	Table 415
Device endpoint registers						
ENDPTSETUPSTAT	R/W	0x1AC	Endpoint setup status	0	0	Table 416
ENDPTPRIME	R/W	0x1B0	Endpoint initialization	0	0	Table 417
ENDPTFLUSH	R/W	0x1B4	Endpoint de-initialization	0	0	Table 418
ENDPTSTAT	RO	0x1B8	Endpoint status	0	0	Table 419
ENDPTCOMPLETE	R/W	0x1BC	Endpoint complete	0	0	Table 420
ENDPTCTRL0	R/W	0x1C0	Endpoint control 0	0	0	Table 421
ENDPTCTRL1	R/W	0x1C4	Endpoint control 1	0	0	Table 422
ENDPTCTRL2	R/W	0x1C8	Endpoint control 2	0	0	Table 422
ENDPTCTRL3	R/W	0x1CC	Endpoint control 3	0	0	Table 422
ENDPTCTRL4	R/W	0x1D0	Endpoint control 4	0	0	Table 422
ENDPTCTRL5	R/W	0x1D4	Endpoint control 5	0	0	Table 422

23.6.1 Use of registers

The register interface has bit functions described for device mode and bit functions described for host mode. However, during OTG operations it is necessary to perform tasks independent of the controller mode.

The only way to transition the controller mode out of host or device mode is by setting the controller reset bit. Therefore, it is also necessary for the OTG tasks to be performed independently of a controller reset as well as independently of the controller mode.

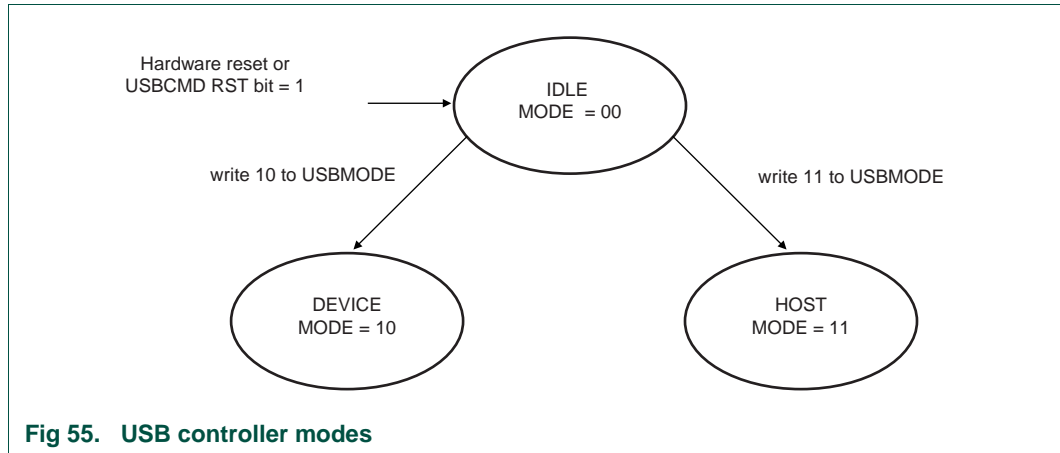

The following registers and register bits are used for OTG operations. The values of these register bits are independent of the controller mode and are not affected by a write to the RESET bit in the USBCMD register.

- All identification registers
- All device/host capabilities registers
- All bits of the OTGSC register ([Section 23.6.16](#))
- The following bits of the PORTSC register ([Section 23.6.15](#)):
 - PTS (parallel interface select)
 - STS (serial transceiver select)
 - PTW (parallel transceiver width)
 - PHCD (PHY low power suspend)
 - WKOC, WKDC, WKCN (wake signals)
 - PIC[1:0] (port indicators)
 - PP (port power)

23.6.2 Device/host capability registers

Table 384. System bus interface configuration register (SBUSCFG - address 0x4000 6090) bit description

Bit	Symbol	Value	Description	Access	Reset value
2:0	AHB_BRST		The burst length used by the USB controller can be selected using these bits. This field controls the RX and TX burst length in BURSTSIZE register.	R/W	0
		0x0	INCR burst of unspecified length		
		0x1	INCR4, non-multiple transfers of INCR4 will be decomposed into singles		
		0x2	INCR8, non-multiple transfers of INCR8, will be decomposed into INCR4 or singles		
		0x3	INCR16, non-multiple transfers of INCR16, will be decomposed into INCR8, INCR4, or singles		
		0x4	This value is reserved and should not be used		
		0x5	INCR4, non-multiple transfers of INCR4 will be decomposed into smaller unspecified length bursts		
		0x6	INCR8, non-multiple transfers of INCR8 will be decomposed into smaller unspecified length bursts		
		0x7	INCR16, non-multiple transfers of INCR16 will be decomposed into smaller unspecified length bursts.		
31:3	-	Reserved	Not used in device mode. Writing a one to this bit when the device mode is selected, will have undefined results.	-	-

Table 385. CAPLENGTH register (CAPLENGTH - address 0x4000 6100) bit description

Bit	Symbol	Description	Reset value	Access
7:0	CAPLENGTH	Indicates offset to add to the register base address at the beginning of the Operational Register	0x40	RO
23:8	HCIVERSION	BCD encoding of the EHCI revision number supported by this host controller.	0x100	RO
31:24	-	These bits are reserved and should be set to zero.	-	-

Table 386. HCSPARAMS register (HCSPARAMS - address 0x4000 6104) bit description

Bit	Symbol	Description	Reset value	Access
3:0	N_PORTS	Number of downstream ports. This field specifies the number of physical downstream ports implemented on this host controller.	0x1	RO
4	PPC	Port Power Control. This field indicates whether the host controller implementation includes port power control.	0x1	RO
7:5	-	These bits are reserved and should be set to zero.	-	-
11:8	N_PCC	Number of Ports per Companion Controller. This field indicates the number of ports supported per internal Companion Controller.	0x0	RO

Table 386. HCSPARAMS register (HCSPARAMS - address 0x4000 6104) ...continued bit

Bit	Symbol	Description	Reset value	Access
15:12	N_CC	Number of Companion Controller. This field indicates the number of companion controllers associated with this USB2.0 host controller.	0x0	RO
16	PI	Port indicators. This bit indicates whether the ports support port indicator control.	0x1	RO
19:17	-	These bits are reserved and should be set to zero.	-	-
23:20	N_PTT	Number of Ports per Transaction Translator. This field indicates the number of ports assigned to each transaction translator within the USB2.0 host controller.	0x0	RO
27:24	N_TT	Number of Transaction Translators. This field indicates the number of embedded transaction translators associated with the USB2.0 host controller.	0x0	RO
31:28	-	These bits are reserved and should be set to zero.	-	-

Table 387. HCCPARAMS register (HCCPARAMS - address 0x4000 6108) bit description

Bit	Symbol	Description	Reset value	Access
0	ADC	64-bit Addressing Capability. If zero, no 64-bit addressing capability is supported.	0	RO
1	PFL	Programmable Frame List Flag. If set to one, then the system software can specify and use a smaller frame list and configure the host controller via the USBCMD register Frame List Size field. The frame list must always be aligned on a 4K-boundary. This requirement ensures that the frame list is always physically contiguous.	1	RO
2	ASP	Asynchronous Schedule Park Capability. If this bit is set to a one, then the host controller supports the park feature for high-speed queue heads in the Asynchronous Schedule. The feature can be disabled or enabled and set to a specific level by using the Asynchronous Schedule Park Mode Enable and Asynchronous Schedule Park Mode Count fields in the USBCMD register.	1	RO
7:4	IST	Isochronous Scheduling Threshold. This field indicates, relative to the current position of the executing host controller, where software can reliably update the isochronous schedule.	0	RO
15:8	EECP	EHCI Extended Capabilities Pointer. This optional field indicates the existence of a capabilities list.	0	RO
31:16	-	These bits are reserved and should be set to zero.	-	-

Table 388. DCIVERSION register (DCIVERSION - address 0x4000 6120) bit description

Bit	Symbol	Description	Reset value	Access
15:0	DCIVERSION	The device controller interface conforms to the two-byte BCD encoding of the interface version number contained in this register.	0x1	RO

Table 389. DCCPARAMS (address 0x4000 6124)

Bit	Symbol	Description	Reset value	Access
4:0	DEN	Device Endpoint Number.	0x4	RO
6:5	-	These bits are reserved and should be set to zero.	-	-
7	DC	Device Capable.	0x1	RO
8	HC	Host Capable.	0x1	RO
31:9	-	These bits are reserved and should be set to zero.	-	-

23.6.3 USB Command register (USBCMD)

The host/device controller executes the command indicated in this register.

23.6.3.1 Device mode

Table 390. USB Command register in device mode (USBCMD_D - address 0x4000 6140) bit description

Bit	Symbol	Value	Description	Access	Reset value
0	RS		Run/Stop	R/W	0
		0	Writing a 0 to this bit will cause a detach event.		
		1	Writing a one to this bit will cause the device controller to enable a pull-up on USB_DP and initiate an attach event. This control bit is not directly connected to the pull-up enable, as the pull-up will become disabled upon transitioning into high-speed mode. Software should use this bit to prevent an attach event before the device controller has been properly initialized.		
1	RST		Controller reset.	R/W	0
			Software uses this bit to reset the controller. This bit is set to zero by the host/device Controller when the reset process is complete. Software cannot terminate the reset process early by writing a zero to this register.		
		0	Set to 0 by hardware when the reset process is complete.		
	1	When software writes a one to this bit, the device controller resets its internal pipelines, timers, counters, state machines etc. to their initial values. Writing a one to this bit when the device is in the attached state is not recommended, since the effect on an attached host is undefined. In order to ensure that the device is not in an attached state before initiating a device controller reset, all primed endpoints should be flushed and the USBCMD Run/Stop bit should be set to 0.			
3:2	-	-	Not used in device mode.	-	0
4	-	-	Not used in device mode.	-	0
5	-	-	Not used in device mode.	-	0
6	-	-	Not used in device mode. Writing a one to this bit when the device mode is selected, will have undefined results.	-	-
7	-	-	Reserved. These bits should be set to 0.	-	-
9:8	-	-	Not used in Device mode.	-	-
10	-	-	Reserved. These bits should be set to 0.	-	0
11	-	-	Not used in Device mode.	-	-
12	-	-	Reserved. These bits should be set to 0.	-	0

Table 390. USB Command register in device mode (USBCMD_D - address 0x4000 6140) bit description ...continued

Bit	Symbol	Value	Description	Access	Reset value
13	SUTW		Setup trip wire During handling a setup packet, this bit is used as a semaphore to ensure that the setup data payload of 8 bytes is extracted from a QH by the DCD without being corrupted. If the setup lockout mode is off (see USBMODE register) then there exists a hazard when new setup data arrives while the DCD is copying the setup data payload from the QH for a previous setup packet. This bit is set and cleared by software and will be cleared by hardware when a hazard exists. (See Section 23.10).	R/W	0
14	ATDTW		Add dTD trip wire This bit is used as a semaphore to ensure the to proper addition of a new dTD to an active (primed) endpoint's linked list. This bit is set and cleared by software during the process of adding a new dTD. See also Section 23.10 . This bit shall also be cleared by hardware when its state machine is hazard region for which adding a dTD to a primed endpoint may go unrecognized.	R/W	0
15	-		Not used in device mode.	-	-
23:16	ITC		Interrupt threshold control. The system software uses this field to set the maximum rate at which the host/device controller will issue interrupts. ITC contains the maximum interrupt interval measured in micro-frames. Valid values are shown below. All other values are reserved. 0x0 = Immediate (no threshold) 0x1 = 1 micro frame. 0x2 = 2 micro frames. 0x8 = 8 micro frames. 0x10 = 16 micro frames. 0x20 = 32 micro frames. 0x40 = 64 micro frames.	R/W	0x8
31:24	-		Reserved		0

23.6.3.2 Host mode

Table 391. USB Command register in host mode (USBCMD_H - address 0x4000 6140) bit description - host mode

Bit	Symbol	Value	Description	Access	Reset value
0	RS		Run/Stop	R/W	0
		0	When this bit is set to 0, the Host Controller completes the current transaction on the USB and then halts. The HC Halted bit in the status register indicates when the Host Controller has finished the transaction and has entered the stopped state. Software should not write a one to this field unless the host controller is in the Halted state (i.e. HCHalted in the USBSTS register is a one).		
		1	When set to a 1, the Host Controller proceeds with the execution of the schedule. The Host Controller continues execution as long as this bit is set to a one.		

Table 391. USB Command register in host mode (USBCMD_H - address 0x4000 6140) bit description - host mode

Bit	Symbol	Value	Description	Access	Reset value
1	RST		Controller reset. Software uses this bit to reset the controller. This bit is set to zero by the host/device controller when the reset process is complete. Software cannot terminate the reset process early by writing a zero to this register.	R/W	0
		0	This bit is set to zero by hardware when the reset process is complete.		
		1	When software writes a one to this bit, the Host Controller resets its internal pipelines, timers, counters, state machines etc. to their initial value. Any transaction currently in progress on USB is immediately terminated. A USB reset is not driven on downstream ports. Software should not set this bit to a one when the HCHalted bit in the USBSTS register is a zero. Attempting to reset an actively running host controller will result in undefined behavior.		
2	FS0		Bit 0 of the Frame List Size bits. See Table 392 . This field specifies the size of the frame list that controls which bits in the Frame Index Register should be used for the Frame List Current index. Note that this field is made up from USBCMD bits 15, 3, and 2.		0
		3	Bit 1 of the Frame List Size bits. See Table 392 .		
4	PSE		This bit controls whether the host controller skips processing the periodic schedule.	R/W	0
		0	Do not process the periodic schedule.		
		1	Use the PERIODICLISTBASE register to access the periodic schedule.		
5	ASE		This bit controls whether the host controller skips processing the asynchronous schedule.	R/W	0
		0	Do not process the asynchronous schedule.		
		1	Use the ASYNCLISTADDR to access the asynchronous schedule.		
6	IAA		This bit is used as a doorbell by software to tell the host controller to issue an interrupt the next time it advances asynchronous schedule.	R/W	0
		0	The host controller sets this bit to zero after it has set the Interrupt on Sync Advance status bit in the USBSTS register to one.		
		1	Software must write a 1 to this bit to ring the doorbell. When the host controller has evicted all appropriate cached schedule states, it sets the Interrupt on Async Advance status bit in the USBSTS register. If the Interrupt on Sync Advance Enable bit in the USBINTR register is one, then the host controller will assert an interrupt at the next interrupt threshold. Software should not write a one to this bit when the asynchronous schedule is inactive. Doing so will yield undefined results.		
7	-	-	Reserved		0
9:8	ASP1_0		Asynchronous schedule park mode Contains a count of the number of successive transactions the host controller is allowed to execute from a high-speed queue head on the Asynchronous schedule before continuing traversal of the Asynchronous schedule. Valid values are 0x1 to 0x3. Remark: Software must not write 00 to this bit when Park Mode Enable is one as this will result in undefined behavior.	R/W	11

Table 391. USB Command register in host mode (USBCMD_H - address 0x4000 6140) bit description - host mode

Bit	Symbol	Value	Description	Access	Reset value
10	-	-	Reserved.	-	0
11	ASPE	-	Asynchronous Schedule Park Mode Enable	R/W	1
		0	Park mode is disabled.		
		1	Park mode is enabled.		
12	-	-	Reserved.	-	0
13	-	-	Not used in Host mode.	-	
14	-	-	Reserved.	-	0
15	FS2	-	Bit 2 of the Frame List Size bits. See Table 392 .	-	0
23:16	ITC	-	Interrupt threshold control. The system software uses this field to set the maximum rate at which the host/device controller will issue interrupts. ITC contains the maximum interrupt interval measured in micro-frames. Valid values are shown below. All other values are reserved. 0x0 = Immediate (no threshold) 0x1 = 1 micro frame. 0x2 = 2 micro frames. 0x8 = 8 micro frames. 0x10 = 16 micro frames. 0x20 = 32 micro frames. 0x40 = 64 micro frames.	R/W	0x8
31:24	-	-	Reserved		0

Table 392. Frame list size values

USBCMD bit 15	USBCMD bit 3	USBCMD bit 2	Frame list size
0	0	0	1024 elements (4096 bytes) - default value
0	0	1	512 elements (2048 bytes)
0	1	0	256 elements (1024 bytes)
0	1	1	128 elements (512 bytes)
1	0	0	64 elements (256 bytes)
1	0	1	32 elements (128 bytes)
1	1	0	16 elements (64 bytes)
1	1	1	8 elements (32 bytes)

23.6.4 USB Status register (USBSTS)

This register indicates various states of the Host/Device controller and any pending interrupts. Software sets a bit to zero in this register by writing a one to it.

Remark: This register does not indicate status resulting from a transaction on the serial bus.

23.6.4.1 Device mode

Table 393. USB Status register in device mode (USBSTS_D - address 0x4000 6144) register bit description

Bit	Symbol	Value	Description	Reset value	Access
0	UI		USB interrupt	0	R/WC
		0	This bit is cleared by software writing a one to it.		
		1	This bit is set by the device controller under the following conditions: <ul style="list-style-type: none"> when the cause of an interrupt is a completion of a USB transaction where the Transfer Descriptor (TD) has an interrupt on complete (IOC) bit set. when a short packet is detected. A short packet is when the actual number of bytes received was less than the expected number of bytes. when a SETUP packet is received. 		
1	UEI		USB error interrupt	0	R/WC
		0	This bit is cleared by software writing a one to it.		
		1	When completion of a USB transaction results in an error condition, this bit is set by the host/device controller. This bit is set along with the USBINT bit, if the TD on which the error interrupt occurred also had its interrupt on complete (IOC) bit set. The device controller detects resume signaling only (see Section 23.10.11.6).		
2	PCI		Port change detect.	0	R/WC
		0	This bit is cleared by software writing a one to it.		
		1	The device controller sets this bit to a one when the port controller enters the full or high-speed operational state. When the port controller exits the full or high-speed operation states due to Reset or Suspend events, the notification mechanisms are the USB Reset Received bit (URI) and the DCSuspend bits (SLI) respectively.		
3	-		Not used in Device mode.		-
4	SEI		System Error	0	R/W/C
			The USB Controller sets this bit to 1 when a serious error occurs during a system access involving the USB Controller module. Conditions that set this bit to 1 include AHB Parity error, AHB Master Abort, and AHB Target Abort. When this error occurs, the USB Controller clears the Run/Stop bit in the Command register to prevent further execution of the scheduled TDs.		
5	AAI		Not used in Device mode.	0	-

Table 393. USB Status register in device mode (USBSTS_D - address 0x4000 6144) register bit description

Bit	Symbol	Value	Description	Reset value	Access
6	URI		USB reset received	0	R/WC
		0	This bit is cleared by software writing a one to it.		
		1	When the device controller detects a USB Reset and enters the default state, this bit will be set to a one.		
7	SRI		SOF received	0	R/WC
		0	This bit is cleared by software writing a one to it.		
		1	When the device controller detects a Start Of (micro) Frame, this bit will be set to a one. When a SOF is extremely late, the device controller will automatically set this bit to indicate that an SOF was expected. Therefore, this bit will be set roughly every 1 ms in device FS mode and every 125 μ s in HS mode and will be synchronized to the actual SOF that is received. Since the device controller is initialized to FS before connect, this bit will be set at an interval of 1ms during the prelude to connect and chirp.		
8	SLI		DCSuspend	0	R/WC
		0	The device controller clears the bit upon exiting from a Suspended state. This bit is cleared by software writing a one to it.		
		1	When a device controller enters a Suspended state from an active state, this bit will be set to a one.		
11:9	-	-	Reserved. Software should only write 0 to reserved bits.		
12	-	-	Not used in Device mode.	0	
13	-	-	Not used in Device mode.	0	
14	-	-	Not used in Device mode.	0	
15	-	-	Not used in Device mode.	0	
16	NAKI		NAK interrupt bit	0	RO
		0	This bit is automatically cleared by hardware when the all the enabled TX/RX Endpoint NAK bits are cleared.		
		1	It is set by hardware when for a particular endpoint both the TX/RX Endpoint NAK bit and the corresponding TX/RX Endpoint NAK Enable bit are set.		
17	-	-	Reserved. Software should only write 0 to reserved bits.	0	-
18	-	-	Not used in Device mode.	0	-
19	-	-	Not used in Device mode.	0	-
31:20	-	-	Reserved. Software should only write 0 to reserved bits.		

23.6.4.2 Host mode

Table 394. USB Status register in host mode (USBSTS_H - address 0x4000 6144) register bit description

Bit	Symbol	Value	Description	Reset value	Access
0	UI		USB interrupt (USBINT)	0	R/WC
		0	This bit is cleared by software writing a one to it.		
		1	This bit is set by the host/device controller when the cause of an interrupt is a completion of a USB transaction where the Transfer Descriptor (TD) has an interrupt on complete (IOC) bit set. This bit is also set by the host/device controller when a short packet is detected. A short packet is when the actual number of bytes received was less than the expected number of bytes.		
1	UEI		USB error interrupt (USBERRINT)	0	R/WC
		0	This bit is cleared by software writing a one to it.		
		1	When completion of a USB transaction results in an error condition, this bit is set by the host/device controller. This bit is set along with the USBINT bit, if the TD on which the error interrupt occurred also had its interrupt on complete (IOC) bit set.		
2	PCI		Port change detect.	0	R/WC
		0	This bit is cleared by software writing a one to it.		
		1	The Host Controller sets this bit to a one when on any port a Connect Status occurs, a Port Enable/Disable Change occurs, or the Force Port Resume bit is set as the result of a J-K transition on the suspended port.		
3	FRI		Frame list roll-over	0	R/WC
		0	This bit is cleared by software writing a one to it.		
		1	The Host Controller sets this bit to a one when the Frame List Index rolls over from its maximum value to zero. The exact value at which the rollover occurs depends on the frame list size. For example, if the frame list size (as programmed in the Frame List Size field of the USBCMD register) is 1024, the Frame Index Register rolls over every time FRINDEX bit 13 toggles. Similarly, if the size is 512, the Host Controller sets this bit to a one every time FRINDEX bit 12 toggles (see Section 23.6.6).		
4	SEI		System Error	0	R/WC
			The USB Controller sets this bit to 1 when a serious error occurs during a system access involving the USB Controller module. Conditions that set this bit to 1 include AHB Parity error, AHB Master Abort, and AHB Target Abort. When this error occurs, the USB Controller clears the Run/Stop bit in the Command register to prevent further execution of the scheduled TDs.		
5	AAI		Interrupt on async advance	0	R/WC
		0	This bit is cleared by software writing a one to it.		
		1	System software can force the host controller to issue an interrupt the next time the host controller advances the asynchronous schedule by writing a one to the Interrupt on Async Advance Doorbell bit in the USBCMD register. This status bit indicates the assertion of that interrupt source.		
6	-	-	Not used by the Host controller.	0	R/WC
7	SRI		SOF received	0	R/WC
		0	This bit is cleared by software writing a one to it.		
		1	In host mode, this bit will be set every 125 μ s and can be used by host controller driver as a time base.		

Table 394. USB Status register in host mode (USBSTS_H - address 0x4000 6144) register bit description ...continued

Bit	Symbol	Value	Description	Reset value	Access
8	-	-	Not used by the Host controller.	-	-
11:9	-	-	Reserved.		
12	HCH		HCHalted	1	RO
		0	The RS bit in USBCMD is set to zero. Set by the host controller.		
		1	The Host Controller sets this bit to one after it has stopped executing because of the Run/Stop bit being set to 0, either by software or by the Host Controller hardware (e.g. because of an internal error).		
13	RCL		Reclamation	0	RO
		0	No empty asynchronous schedule detected.		
		1	An empty asynchronous schedule is detected. Set by the host controller.		
14	PS		Periodic schedule status	0	RO
			This bit reports the current real status of the Periodic Schedule. The Host Controller is not required to immediately disable or enable the Periodic Schedule when software transitions the Periodic Schedule Enable bit in the USBCMD register. When this bit and the Periodic Schedule Enable bit are the same value, the Periodic Schedule is either enabled (if both are 1) or disabled (if both are 0).		
		0	The periodic schedule status is disabled.		
		1	The periodic schedule status is enabled.		
15	AS		Asynchronous schedule status	0	
			This bit reports the current real status of the Asynchronous Schedule. The Host Controller is not required to immediately disable or enable the Asynchronous Schedule when software transitions the Asynchronous Schedule Enable bit in the USBCMD register. When this bit and the Asynchronous Schedule Enable bit are the same value, the Asynchronous Schedule is either enabled (if both are 1) or disabled (if both are 0).		
		0	Asynchronous schedule status is disabled.		
		1	Asynchronous schedule status is enabled.		
16	-		Not used on Host mode.	0	-
17	-		Reserved.		
18	UAI		USB host asynchronous interrupt (USBHSTASYNCINT)	0	R/WC
		0	This bit is cleared by software writing a one to it.		
		1	This bit is set by the Host Controller when the cause of an interrupt is a completion of a USB transaction where the Transfer Descriptor (TD) has an interrupt on complete (IOC) bit set and the TD was from the asynchronous schedule. This bit is also set by the Host when a short packet is detected and the packet is on the asynchronous schedule. A short packet is when the actual number of bytes received was less than the expected number of bytes.		

Table 394. USB Status register in host mode (USBSTS_H - address 0x4000 6144) register bit description ...continued

Bit	Symbol	Value	Description	Reset value	Access
19	UPI		USB host periodic interrupt (USBHSTPERINT)	0	R/WC
		0	This bit is cleared by software writing a one to it.		
		1	This bit is set by the Host Controller when the cause of an interrupt is a completion of a USB transaction where the Transfer Descriptor (TD) has an interrupt on complete (IOC) bit set and the TD was from the periodic schedule. This bit is also set by the Host Controller when a short packet is detected and the packet is on the periodic schedule. A short packet is when the actual number of bytes received was less than the expected number of bytes.		
31:20 -					

23.6.5 USB Interrupt register (USBINTR)

The software interrupts are enabled with this register. An interrupt is generated when a bit is set and the corresponding interrupt is active. The USB Status register (USBSTS) still shows interrupt sources even if they are disabled by the USBINTR register, allowing polling of interrupt events by the software. All interrupts must be acknowledged by software by clearing (that is writing a 1 to) the corresponding bit in the USBSTS register.

23.6.5.1 Device mode

Table 395. USB Interrupt register in device mode (USBINTR_D - address 0x4000 6148) bit description

Bit	Symbol	Description	Reset value	Access
0	UE	USB interrupt enable When this bit is one, and the USBINT bit in the USBSTS register is one, the host/device controller will issue an interrupt at the next interrupt threshold. The interrupt is acknowledged by software clearing the USBINT bit in USBSTS.	0	R/W
1	UEE	USB error interrupt enable When this bit is a one, and the USBERRINT bit in the USBSTS register is a one, the host/device controller will issue an interrupt at the next interrupt threshold. The interrupt is acknowledged by software clearing the USBERRINT bit in the USBSTS register.	0	R/W
2	PCE	Port change detect enable When this bit is a one, and the Port Change Detect bit in the USBSTS register is a one, the host/device controller will issue an interrupt. The interrupt is acknowledged by software clearing the Port Change Detect bit in USBSTS.	0	R/W
3	-	Not used by the Device controller.		
4	SEE	System Error Enable When this bit is a one, and the System Error bit in the USBSTS register is a one, the host/device controller will issue an interrupt. The interrupt is acknowledged by software clearing the System Error bit in USBSTS register.	0	R/W
5	-	Not used by the Device controller.		
6	URE	USB reset enable When this bit is a one, and the USB Reset Received bit in the USBSTS register is a one, the device controller will issue an interrupt. The interrupt is acknowledged by software clearing the USB Reset Received bit.	0	R/W

Table 395. USB Interrupt register in device mode (USBINTR_D - address 0x4000 6148) bit description ...continued

Bit	Symbol	Description	Reset value	Access
7	SRE	SOF received enable When this bit is a one, and the SOF Received bit in the USBSTS register is a one, the device controller will issue an interrupt. The interrupt is acknowledged by software clearing the SOF Received bit.	0	R/W
8	SLE	Sleep enable When this bit is a one, and the DCSuspend bit in the USBSTS register transitions, the device controller will issue an interrupt. The interrupt is acknowledged by software writing a one to the DCSuspend bit.	0	R/W
15:9	-	Reserved	-	-
16	NAKE	NAK interrupt enable This bit is set by software if it wants to enable the hardware interrupt for the NAK Interrupt bit. If both this bit and the corresponding NAK Interrupt bit are set, a hardware interrupt is generated.	0	R/W
17	-	Reserved		
18	-	Not used by the Device controller.		
19	-	Not used by the Device controller.		
31:20	-	Reserved		

23.6.5.2 Host mode

Table 396. USB Interrupt register in host mode (USBINTR_H - address 0x4000 6148) bit description

Bit	Symbol	Description	Reset value	Access
0	UE	USB interrupt enable When this bit is one, and the USBINT bit in the USBSTS register is one, the host/device controller will issue an interrupt at the next interrupt threshold. The interrupt is acknowledged by software clearing the USBINT bit in USBSTS.	0	R/W
1	UEE	USB error interrupt enable When this bit is a one, and the USBERRINT bit in the USBSTS register is a one, the host/device controller will issue an interrupt at the next interrupt threshold. The interrupt is acknowledged by software clearing the USBERRINT bit in the USBSTS register.	0	R/W
2	PCE	Port change detect enable When this bit is a one, and the Port Change Detect bit in the USBSTS register is a one, the host/device controller will issue an interrupt. The interrupt is acknowledged by software clearing the Port Change Detect bit in USBSTS.	0	R/W
3	FRE	Frame list rollover enable When this bit is a one, and the Frame List Rollover bit in the USBSTS register is a one, the host controller will issue an interrupt. The interrupt is acknowledged by software clearing the Frame List Rollover bit.		
4	SEE	System Error Enable When this bit is a one, and the System Error bit in the USBSTS register is a one, the host/device controller will issue an interrupt. The interrupt is acknowledged by software clearing the System Error bit in USBSTS register.	0	R/W

Table 396. USB Interrupt register in host mode (USBINTR_H - address 0x4000 6148) bit description ...continued

Bit	Symbol	Description	Reset value	Access
5	AAE	Interrupt on asynchronous advance enable When this bit is a one, and the Interrupt on Async Advance bit in the USBSTS register is a one, the host controller will issue an interrupt at the next interrupt threshold. The interrupt is acknowledged by software clearing the Interrupt on Async Advance bit.	0	R/W
6	-	Not used by the Host controller.	0	-
7	SRE	If this bit is one and the SRI bit in the USBSTS register is one, the host controller will issue an interrupt. In host mode, the SRI bit will be set every 125 μ s and can be used by the host controller as a time base. The interrupt is acknowledged by software clearing the SRI bit in the USBSTS register.	0	-
8	-	Not used by the Host controller.	0	-
15:9	-	Reserved		
16	-	Not used by the host controller.	0	R/W
17	-	Reserved		
18	UAIE	USB host asynchronous interrupt enable When this bit is a one, and the USBHSTASYNCINT bit in the USBSTS register is a one, the host controller will issue an interrupt at the next interrupt threshold. The interrupt is acknowledged by software clearing the USBHSTASYNCINT bit.	0	R/W
19	UPIA	USB host periodic interrupt enable When this bit is a one, and the USBHSTPERINT bit in the USBSTS register is a one, the host controller will issue an interrupt at the next interrupt threshold. The interrupt is acknowledged by software clearing the USBHSTPERINT bit.	0	R/W
31:20	-	Reserved		

23.6.6 Frame index register (FRINDEX)

23.6.6.1 Device mode

In Device mode this register is read only, and the device controller updates the FRINDEX[13:3] register from the frame number indicated by the SOF marker. Whenever a SOF is received by the USB bus, FRINDEX[13:3] will be checked against the SOF marker. If FRINDEX[13:3] is different from the SOF marker, FRINDEX[13:3] will be set to the SOF value and FRINDEX[2:0] will be set to zero (i.e. SOF for 1 ms frame). If FRINDEX [13:3] is equal to the SOF value, FRINDEX[2:0] will be incremented (i.e. SOF for 125 μ s micro-frame) by hardware.

Table 397. USB frame index register in device mode (FRINDEX_D - address 0x4000 614C) bit description

Bit	Symbol	Description	Reset value	Access
2:0	FRINDEX2_0	Current micro frame number	N/A	RO
13:3	FRINDEX13_3	Current frame number of the last frame transmitted	N/A	RO
31:14	-	Reserved	N/A	

23.6.6.2 Host mode

This register is used by the host controller to index the periodic frame list. The register updates every 125 μ s (once each micro-frame). Bits[N: 3] are used to select a particular entry in the Periodic Frame List during periodic schedule execution. The number of bits used for the index depends on the size of the frame list as set by system software in the Frame List Size field in the USBCMD register.

This register must be written as a DWord. Byte writes produce undefined results. This register cannot be written unless the Host Controller is in the 'Halted' state as indicated by the HCHalted bit in the USBSTS register (host mode). A write to this register while the Run/Stop bit is set to a one produces undefined results. Writes to this register also affect the SOF value.

Table 398. USB frame index register in host (FRINDEX_H - address 0x4000 614C) bit description

Bit	Symbol	Description	Reset value	Access
2:0	FRINDEX2_0	Current micro frame number	N/A	R/W
12:3	FRINDEX12_3	Frame list current index.	N/A	R/W
31:13	-	Reserved	N/A	

Table 399. Number of bits used for the frame list index

USBCMD bit 15	USBCMD bit 3	USBCMD bit 2	Frame list size	N
0	0	0	1024 elements (4096 bytes). Default value.	12
0	0	1	512 elements (2048 bytes)	11
0	1	0	256 elements (1024 bytes)	10
0	1	1	128 elements (512 bytes)	9
1	0	0	64 elements (256 bytes)	8
1	0	1	32 elements (128 bytes)	7
1	1	0	16 elements (64 bytes)	6
1	1	1	8 elements (32 bytes)	5

23.6.7 Device address (DEVICEADDR - device) and Periodic List Base (PERIODICLISTBASE- host) registers

23.6.7.1 Device mode

The upper seven bits of this register represent the device address. After any controller reset or a USB reset, the device address is set to the default address (0). The default address will match all incoming addresses. Software shall reprogram the address after receiving a SET_ADDRESS descriptor.

The USBADRA bit is used to accelerate the SET_ADDRESS sequence by allowing the DCD to preset the USBADR register bits before the status phase of the SET_ADDRESS descriptor.

Table 400. USB Device Address register in device mode (DEVICEADDR - address 0x4000 6154) bit description

Bit	Symbol	Value	Description	Reset value	Access
23:0	-		Reserved	0	-
24	USBADRA	0	Device address advance		
		0	Any write to USBADR are instantaneous.		
		1	When the user writes a one to this bit at the same time or before USBADR is written, the write to USBADR fields is staged and held in a hidden register. After an IN occurs on endpoint 0 and is acknowledged, USBADR will be loaded from the holding register. Hardware will automatically clear this bit on the following conditions: <ul style="list-style-type: none"> • IN is ACKed to endpoint 0. USBADR is updated from the staging register. • OUT/SETUP occurs on endpoint 0. USBADR is not updated. • Device reset occurs. USBADR is set to 0. Remark: After the status phase of the SET_ADDRESS descriptor, the DCD has 2 ms to program the USBADR field. This mechanism will ensure this specification is met when the DCD can not write the device address within 2 ms from the SET_ADDRESS status phase. If the DCD writes the USBADR with USBADRA=1 after the SET_ADDRESS data phase (before the prime of the status phase), the USBADR will be programmed instantly at the correct time and meet the 2 ms USB requirement.		
31:25	USBADR		USB device address	0	R/W

23.6.7.2 Host mode

This 32-bit register contains the beginning address of the Periodic Frame List in the system memory. The host controller driver (HCD) loads this register prior to starting the schedule execution by the Host Controller. The memory structure referenced by this physical memory pointer is assumed to be 4 kB aligned. The contents of this register are combined with the Frame Index Register (FRINDEX) to enable the Host Controller to step through the Periodic Frame List in sequence.

Table 401. USB Periodic List Base register in host mode (PERIODICLISTBASE - address 0x4000 6154) bit description

Bit	Symbol	Description	Reset value	Access
11:0	-	Reserved	-	-
31:12	PERBASE31_12	Base Address (Low) These bits correspond to the memory address signals 31:12.	-	R/W

23.6.8 Endpoint List Address register (ENDPOINTLISTADDR - device) and Asynchronous List Address (ASYNCLISTADDR - host) registers

23.6.8.1 Device mode

In device mode, this register contains the address of the top of the endpoint list in system memory. Bits[10:0] of this register cannot be modified by the system software and will always return a zero when read. The memory structure referenced by this physical memory pointer is assumed 64 byte aligned. The entire device endpoint list must be aligned on a 2 kB boundary.

Table 402. USB Endpoint List Address register in device mode (ENDPOINTLISTADDR - address 0x4000 6158) bit description

Bit	Symbol	Description	Reset value	Access
10:0	-	Reserved	0	-
31:11	EPBASE31_11	Endpoint list pointer (low) These bits correspond to memory address signals 31:11, respectively. This field will reference a list of up to 12 Queue Heads (QH). (i.e. one queue head per endpoint and direction.)	-	R/W

23.6.8.2 Host mode

This 32-bit register contains the address of the next asynchronous queue head to be executed by the host. Bits [4:0] of this register cannot be modified by the system software and will always return a zero when read.

Table 403. USB Asynchronous List Address register in host mode (ASYNCLISTADDR- address 0x4000 6158) bit description

Bit	Symbol	Description	Reset value	Access
4:0	-	Reserved	0	-
31:5	ASYBASE31_5	Link pointer (Low) LPL These bits correspond to memory address signals 31:5, respectively. This field may only reference a Queue Head (OH).	-	R/W

23.6.9 TT Control register (TTCTRL)

23.6.9.1 Device mode

This register is not used in device mode.

23.6.9.2 Host mode

This register contains parameters needed for internal TT operations. This register is used by the host controller only. Writes must be in Dwords.

Table 404. USB TT Control register in host mode (TTCTRL - address 0x4000 615C) bit description

Bit	Symbol	Description	Reset value	Access
23:0	-	Reserved.	0	-
30:24	TTHA	Hub address when FS or LS device are connected directly.	N/A	R/W
31	-	Reserved.	0	

23.6.10 Burst Size register (BURSTSIZE)

This register is used to control and dynamically change the burst size used during data movement on the master interface of the USB DMA controller. Writes must be in Dwords.

The default for the length of a burst of 32-bit words for RX and TX DMA data transfers is 16 words each.

Remark: The value of the fields TXPBURST/RXPBURST in register BURSTSIZE depends on the setting of the SBUSCFG register.

Table 405. USB burst size register (BURSTSIZE - address 0x4000 6160) bit description - device/host mode

Bit	Symbol	Description	Reset value	Access
7:0	RXPBURST	Programmable RX burst length This register represents the maximum length of a burst in 32-bit words while moving data from the USB bus to system memory.	0x10	R/W
15:8	TXPBURST	Programmable TX burst length This register represents the maximum length of a burst in 32-bit words while moving data from system memory to the USB bus.	0x10	R/W
31:16	-	Reserved.	-	-

23.6.11 Transfer buffer Fill Tuning register (TXFILLTUNING)

23.6.11.1 Device controller

This register is not used in device mode.

23.6.11.2 Host controller

The fields in this register control performance tuning associated with how the host controller posts data to the TX latency FIFO before moving the data onto the USB bus. The specific areas of performance include the how much data to post into the FIFO and an estimate for how long that operation should take in the target system.

Definitions:

T_0 = Standard packet overhead

T_1 = Time to send data payload

T_{ff} = Time to fetch packet into TX FIFO up to specified level

T_s = Total packet flight time (send-only) packet; $T_s = T_0 + T_1$

T_p = Total packet time (fetch and send) packet; $T_p = T_{ff} + T_0 + T_1$

Upon discovery of a transmit (OUT/SETUP) packet in the data structures, host controller checks to ensure T_p remains before the end of the (micro) frame. If so it proceeds to pre-fill the TX FIFO. If at anytime during the pre-fill operation the time remaining the [micro]frame is $< T_s$ then the packet attempt ceases and the packet is tried at a later time. Although this is not an error condition and the host controller will eventually recover, a mark will be made the scheduler health counter to note the occurrence of a “backoff” event. When a back-off event is detected, the partial packet fetched may need to be discarded from the latency buffer to make room for periodic traffic that will begin after the next SOF. Too many back-off events can waste bandwidth and power on the system bus and thus should be minimized (not necessarily eliminated). Backoffs can be minimized with use of the TSCHEALTH (T_{ff}) described below.

Table 406. USB Transfer buffer Fill Tuning register in host mode (TXFILLTUNING - address 0x4000 6164) bit description

Bit	Symbol	Description	Reset value	Access
7:0	TXSCHOH	FIFO burst threshold This register controls the number of data bursts that are posted to the TX latency FIFO in host mode before the packet begins on to the bus. The minimum value is 2 and this value should be as low as possible to maximize USB performance. A higher value can be used in systems with unpredictable latency and/or insufficient bandwidth where the FIFO may underrun because the data transferred from the latency FIFO to USB occurs before it can be replenished from system memory. This value is ignored if the Stream Disable bit in USBMODE register is set.	0x2	R/W
12:8	TXSCHEALTH	Scheduler health counter This register increments when the host controller fails to fill the TX latency FIFO to the level programmed by TXFIFOTHRES before running out of time to send the packet before the next Start-Of-Frame . This health counter measures the number of times this occurs to provide feedback to selecting a proper TXSCHOH. Writing to this register will clear the counter. The maximum value is 31.	0x0	R/W
15:13	-	Reserved	-	-
21:16	TXFIFOTHRES	Scheduler overhead This register adds an additional fixed offset to the schedule time estimator described above as T_{ff} . As an approximation, the value chosen for this register should limit the number of back-off events captured in the TXSCHHEALTH to less than 10 per second in a highly utilized bus. Choosing a value that is too high for this register is not desired as it can needlessly reduce USB utilization. The time unit represented in this register is 1.267 μ s when a device is connected in High-Speed Mode for OTG and SPH. The time unit represented in this register is 6.333 μ s when a device is connected in Low/Full Speed Mode for OTG and SPH.	0x0	R/W
31:22	-	Reserved		

23.6.12 BINTERVAL register

This register defines the bInterval value which determines the length of the virtual frame (see [Section 23.7.7](#)). The BINTERVAL register divides the SOF signal by the value BINT.

Remark: The BINTERVAL register is not related to the bInterval endpoint descriptor field in the USB specification.

Table 407. USB BINTERVAL register (BINTERVAL - address 0x4000 6174) bit description

Bit	Symbol	Description	Reset value	Access
3:0	BINT	bInterval value (see Section 23.7.7)	0x00	R/W
31:4	-	Reserved	-	-

23.6.13 USB Endpoint NAK register (ENDPTNAK)

23.6.13.1 Device mode

This register indicates when the device sends a NAK handshake on an endpoint. Each Tx and Rx endpoint has a bit in the EPTN and EPRN field respectively.

A bit in this register is cleared by writing a 1 to it.

Table 408. USB endpoint NAK register (ENDPTNAK - address 0x4000 6178) bit description

Bit	Symbol	Description	Reset value	Access
5:0	EPRN	Rx endpoint NAK Each RX endpoint has one bit in this field. The bit is set when the device sends a NAK handshake on a received OUT or PING token for the corresponding endpoint. Bit 5 corresponds to endpoint 5. ... Bit 1 corresponds to endpoint 1. Bit 0 corresponds to endpoint 0.	0x00	R/WC
15:6	-	Reserved	-	-
21:16	EPTN	Tx endpoint NAK Each TX endpoint has one bit in this field. The bit is set when the device sends a NAK handshake on a received IN token for the corresponding endpoint. Bit 5 corresponds to endpoint 5. ... Bit 1 corresponds to endpoint 1. Bit 0 corresponds to endpoint 0.	0x00	R/WC
31:22	-	Reserved	-	-

23.6.13.2 Host mode

This register is not used in host mode.

23.6.14 USB Endpoint NAK Enable register (ENDPTNAKEN)

23.6.14.1 Device mode

Each bit in this register enables the corresponding bit in the ENDPTNAK register. Each Tx and Rx endpoint has a bit in the EPTNE and EPRNE field respectively.

Table 409. USB Endpoint NAK Enable register (ENDPTNAKEN - address 0x4000 617C) bit description

Bit	Symbol	Description	Reset value	Access
5:0	EPRNE	Rx endpoint NAK enable Each bit enables the corresponding RX NAK bit. If this bit is set and the corresponding RX endpoint NAK bit is set, the NAK interrupt bit is set. Bit 5 corresponds to endpoint 5. ... Bit 1 corresponds to endpoint 1. Bit 0 corresponds to endpoint 0.	0x00	R/W
15:6	-	Reserved	-	-
21:16	EPTNE	Tx endpoint NAK Each bit enables the corresponding TX NAK bit. If this bit is set and the corresponding TX endpoint NAK bit is set, the NAK interrupt bit is set. Bit 5 corresponds to endpoint 5. ... Bit 1 corresponds to endpoint 1. Bit 0 corresponds to endpoint 0.	0x00	R/W
31:22	-	Reserved	-	-

23.6.14.2 Host mode

This register is not used in host mode.

23.6.15 Port Status and Control register (PORTSC1)

23.6.15.1 Device mode

The device controller implements one port register, and it does not support power control. Port control in device mode is used for status port reset, suspend, and current connect status. It is also used to initiate test mode or force signaling. This register allows software to put the PHY into low-power Suspend mode and disable the PHY clock.

Table 410. Port Status and Control register in device mode (PORTSC1_D - address 0x4000 6184) bit description

Bit	Symbol	Value	Description	Reset value	Access
0	CCS		Current connect status	0	RO
		0	Device not attached A zero indicates that the device did not attach successfully or was forcibly disconnected by the software writing a zero to the Run bit in the USBCMD register. It does not state the device being disconnected or suspended.		
		1	Device attached. A one indicates that the device successfully attached and is operating in either high-speed mode or full-speed mode as indicated by the High Speed Port bit in this register.		
1	-	-	Not used in device mode	0	-
2	PE		Port enable. This bit is always 1. The device port is always enabled.	1	RO
3	PEC		Port enable/disable change This bit is always 0. The device port is always enabled.	0	RO

Table 410. Port Status and Control register in device mode (PORTSC1_D - address 0x4000 6184) bit description

Bit	Symbol	Value	Description	Reset value	Access
5:4	-	-	Reserved	0	RO
6	FPR		Force port resume After the device has been in Suspended state for 5 ms or more, software must set this bit to one to drive resume signaling before clearing. The device controller will set this bit to one if a J-to-K transition is detected while the port is in the Suspended state. The bit will be cleared when the device returns to normal operation. When this bit transitions to a one because a J-to-K transition detected, the Port Change Detect bit in the USBSTS register is set to one as well.	0	R/W
		0	No resume (K-state) detected/driven on port.		
		1	Resume detected/driven on port.		
7	SUSP		Suspend In device mode, this is a read-only status bit .	0	RO
		0	Port not in Suspended state		
		1	Port in Suspended state		
8	PR		Port reset In device mode, this is a read-only status bit. A device reset from the USB bus is also indicated in the USBSTS register.	0	RO
		0	Port is not in the reset state.		
		1	Port is in the reset state.		
9	HSP		High-speed status Remark: This bit is redundant with bits 27:26 (PSPD) in this register. It is implemented for compatibility reasons.	0	RO
		0	Host/device connected to the port is not in High-speed mode.		
		1	Host/device connected to the port is in High-speed mode.		
11:10	-	-	Not used in device mode.		
12	-	-	Not used in device mode.		
13	-	-	Reserved	-	-
15:14	PIC1_0		Port indicator control Writing to this field effects the value of the USB0_IND[1:0] pins.	00	R/W
		0x0	Port indicators are off.		
		0x1	amber		
		0x2	green		
		0x3	undefined		

Table 410. Port Status and Control register in device mode (PORTSC1_D - address 0x4000 6184) bit description

Bit	Symbol	Value	Description	Reset value	Access
19:16	PTC3_0		Port test control Any value other than 0000 indicates that the port is operating in test mode. The FORCE_ENABLE_FS and FORCE_ENABLE_LS are extensions to the test mode support specified in the EHCI specification. Writing the PTC field to any of the FORCE_ENABLE_HS/FS/LS values will force the port into the connected and enabled state at the selected speed. Writing the PTC field back to TEST_MODE_DISABLE will allow the port state machines to progress normally from that point. Values 0111 to 1111 are not valid.	0000	R/W
		0x0	TEST_MODE_DISABLE		
		0x1	J_STATE		
		0x2	K_STATE		
		0x3	SE0 (host)/NAK (device)		
		0x4	Packet		
		0x5	FORCE_ENABLE_HS		
		0x6	FORCE_ENABLE_FS		
20	-	-	Not used in device mode. This bit is always 0 in device mode.	0	-
21	-	-	Not used in device mode. This bit is always 0 in device mode.	0	-
22	-	-	Not used in device mode. This bit is always 0 in device mode.	0	-
23	PHCD		PHY low power suspend - clock disable (PLPSCD) In device mode, The PHY can be put into Low Power Suspend – Clock Disable when the device is not running (USBCMD Run/Stop = 0) or the host has signaled suspend (PORTSC SUSPEND = 1). Low power suspend will be cleared automatically when the host has signaled resume. Before forcing a resume from the device, the device controller driver must clear this bit.	0	R/W
		0	Writing a 0 enables the PHY clock. Reading a 0 indicates the status of the PHY clock (enabled).		
		1	Writing a 1 disables the PHY clock. Reading a 1 indicates the status of the PHY clock (disabled).		
24	PFSC		Port force full speed connect	0	R/W
		0	Port connects at any speed.		
		1	Writing this bit to a 1 will force the port to only connect at full speed. It disables the chirp sequence that allows the port to identify itself as High-speed. This is useful for testing FS configurations with a HS host, hub or device.		
25	-	-	Reserved		
27:26	PSPD		Port speed This register field indicates the speed at which the port is operating.	0	RO
		0x0	Full-speed		
		0x1	invalid in device mode		
		0x2	High-speed		
31:28	-	-	Reserved	-	-

23.6.15.2 Host mode

The host controller uses one port. The register is only reset when power is initially applied or in response to a controller reset. The initial conditions of the port are:

- No device connected
- Port disabled

If the port has power control, this state remains until software applies power to the port by setting port power to one in the PORTSC register.

Table 411. Port Status and Control register in host mode (PORTSC1_H - address 0x4000 6184) bit description

Bit	Symbol	Value	Description	Reset value	Access
0	CCS		Current connect status This value reflects the current state of the port and may not correspond directly to the event that caused the CSC bit to be set. This bit is 0 if PP (Port Power bit) is 0. Software clears this bit by writing a 1 to it.	0	R/WC
		0	No device is present.		
		1	Device is present on the port.		
1	CSC		Connect status change Indicates a change has occurred in the port's Current Connect Status. The host/device controller sets this bit for all changes to the port device connect status, even if system software has not cleared an existing connect status change. For example, the insertion status changes twice before system software has cleared the changed condition, hub hardware will be setting an already-set bit (i.e., the bit will remain set). Software clears this bit by writing a one to it. This bit is 0 if PP (Port Power bit) is 0	0	R/WC
		0	No change in current status.		
		1	Change in current status.		
2	PE		Port enable. Ports can only be enabled by the host controller as a part of the reset and enable. Software cannot enable a port by writing a one to this field. Ports can be disabled by either a fault condition (disconnect event or other fault condition) or by the host software. Note that the bit status does not change until the port state actually changes. There may be a delay in disabling or enabling a port due to other host controller and bus events. When the port is disabled, downstream propagation of data is blocked except for reset. This bit is 0 if PP (Port Power bit) is 0.	0	R/W
		0	Port disabled.		
		1	Port enabled.		

Table 411. Port Status and Control register in host mode (PORTSC1_H - address 0x4000 6184) bit description

Bit	Symbol	Value	Description	Reset value	Access
3	PEC		Port disable/enable change	0	R/WC
		0	No change.		
		1	Port enabled/disabled status has changed.		
4	OCA		Over-current active This bit will automatically transition from 1 to 0 when the over-current condition is removed.	0	RO
		0	The port does not have an over-current condition.		
		1	The port has currently an over-current condition.		
5	OCC		Over-current change This bit gets set to one when there is a change to Over-current Active. Software clears this bit by writing a one to this bit position.	0	R/WC
6	FPR		Force port resume	0	R/W
			Software sets this bit to one to drive resume signaling. The Host Controller sets this bit to one if a J-to-K transition is detected while the port is in the Suspended state. When this bit transitions to a one because a J-to-K transition is detected, the Port Change Detect bit in the USBSTS register is also set to one. This bit will automatically change to zero after the resume sequence is complete. This behavior is different from EHCI where the host controller driver is required to set this bit to a zero after the resume duration is timed in the driver.		
			Note that when the Host controller owns the port, the resume sequence follows the defined sequence documented in the USB Specification Revision 2.0. The resume signaling (Full-speed K) is driven on the port as long as this bit remains a one. This bit will remain a one until the port has switched to the high-speed idle. Writing a zero has no affect because the port controller will time the resume operation clear the bit the port control state switches to HS or FS idle.		
			This bit is 0 if PP (Port Power bit) is 0.		
	0	No resume (K-state) detected/driven on port.			
	1	Resume detected/driven on port.			

Table 411. Port Status and Control register in host mode (PORTSC1_H - address 0x4000 6184) bit description

Bit	Symbol	Value	Description	Reset value	Access
7	SUSP		Suspend Together with the PE (Port enabled bit), this bit describes the port states, see Table 412 . The host controller will unconditionally set this bit to zero when software sets the Force Port Resume bit to zero. The host controller ignores a write of zero to this bit. If host software sets this bit to a one when the port is not enabled (i.e. Port enabled bit is a zero) the results are undefined. This bit is 0 if PP (Port Power bit) is 0.	0	R/W
		0	Port not in Suspended state		
		1	Port in Suspended state When in Suspended state, downstream propagation of data is blocked on this port, except for port reset. The blocking occurs at the end of the current transaction if a transaction was in progress when this bit was written to 1. In the Suspended state, the port is sensitive to resume detection. Note that the bit status does not change until the port is suspended and that there may be a delay in suspending a port if there is a transaction currently in progress on the USB.		
8	PR		Port reset When software writes a one to this bit the bus-reset sequence as defined in the USB Specification Revision 2.0 is started. This bit will automatically change to zero after the reset sequence is complete. This behavior is different from EHCI where the host controller driver is required to set this bit to a zero after the reset duration is timed in the driver. This bit is 0 if PP (Port Power bit) is 0.	0	R/W
		0	Port is not in the reset state.		
		1	Port is in the reset state.		
9	HSP		High-speed status	0	RO
		0	Host/device connected to the port is not in High-speed mode.		
		1	Host/device connected to the port is in High-speed mode.		
11:10	LS		Line status These bits reflect the current logical levels of the USB_DP and USB_DM signal lines. USB_DP corresponds to bit 11 and USB_DM to bit 10. In host mode, the use of linestate by the host controller driver is not necessary for this controller (unlike EHCI) because the controller hardware manages the connection of LS and FS.	0x3	RO
	0x0	SE0 (USB_DP and USB_DM LOW)			
	0x1	J-state (USB_DP HIGH and USB_DM LOW)			
	0x2	K-state (USB_DP LOW and USB_DM HIGH)			
	0x3	Undefined			

Table 411. Port Status and Control register in host mode (PORTSC1_H - address 0x4000 6184) bit description

Bit	Symbol	Value	Description	Reset value	Access
12	PP	-	Port power control Host/OTG controller requires port power control switches. This bit represents the current setting of the switch (0=off, 1=on). When power is not available on a port (i.e. PP equals a 0), the port is non-functional and will not report attaches, detaches, etc. When an over-current condition is detected on a powered port and PPC is a one, the PP bit in each affected port may be transitioned by the host controller driver from a one to a zero (removing power from the port).	0	R/W
		0	Port power off.		
		1	Port power on.		
13	-	-	Reserved	0	-
15:14	PIC1_0		Port indicator control Writing to this field effects the value of the pins USB0_IND1 and USB0_IND0.	00	R/W
		0x0	Port indicators are off.		
		0x1	Amber		
		0x2	Green		
		0x3	Undefined		
19:16	PTC3_0		Port test control Any value other than 0000 indicates that the port is operating in test mode. The FORCE_ENABLE_FS and FORCE_ENABLE_LS are extensions to the test mode support specified in the EHCI specification. Writing the PTC field to any of the FORCE_ENABLE_{HS/FS/LS} values will force the port into the connected and enabled state at the selected speed. Writing the PTC field back to TEST_MODE_DISABLE will allow the port state machines to progress normally from that point. Values 0x8 to 0xF are reserved.	0000	R/W
		0x0	TEST_MODE_DISABLE		
		0x1	J_STATE		
		0x2	K_STATE		
		0x3	SE0 (host)/NAK (device)		
		0x4	Packet		
		0x5	FORCE_ENABLE_HS		
		0x6	FORCE_ENABLE_FS		
		0x7	FORCE_ENABLE_LS		
20	WKCEN		Wake on connect enable (WKCENNT_E) This bit is 0 if PP (Port Power bit) is 0	0	R/W
		0	Disables the port to wake up on device connects.		
		1	Writing this bit to a one enables the port to be sensitive to device connects as wake-up events.		
21	WKDC		Wake on disconnect enable (WKDSCNNT_E) This bit is 0 if PP (Port Power bit) is 0.	0	R/W
		0	Disables the port to wake up on device disconnects.		
		1	Writing this bit to a one enables the port to be sensitive to device disconnects as wake-up events.		

Table 411. Port Status and Control register in host mode (PORTSC1_H - address 0x4000 6184) bit description

Bit	Symbol	Value	Description	Reset value	Access
22	WKOC		Wake on over-current enable (WKOC_E)	0	R/W
		0	Disables the port to wake up on over-current events.		
		1	Writing a one to this bit enabled the port to be sensitive to over-current conditions as wake-up events.		
23	PHCD		PHY low power suspend - clock disable (PLPSCD) In host mode, the PHY can be put into Low Power Suspend – Clock Disable when the downstream device has been put into suspend mode or when no downstream device is connected. Low power suspend is completely under the control of software.	0	R/W
		0	Writing a 0 enables the PHY clock. Reading a 0 indicates the status of the PHY clock (enabled).		
		1	Writing a 1 disables the PHY clock. Reading a 1 indicates the status of the PHY clock (disabled).		
24	PFSC		Port force full speed connect	0	R/W
		0	Port connects at any speed.		
		1	Writing this bit to a 1 will force the port to only connect at Full Speed. It disables the chirp sequence that allows the port to identify itself as High Speed. This is useful for testing FS configurations with a HS host, hub or device.		
25	-	-	Reserved		
27:26	PSPD		Port speed	0	RO
			This register field indicates the speed at which the port is operating. For HS mode operation in the host controller and HS/FS operation in the device controller the port routing steers data to the Protocol engine. For FS and LS mode operation in the host controller, the port routing steers data to the Protocol Engine w/ Embedded Transaction Translator.		
		0x0	Full-speed		
		0x1	Low-speed		
		0x2	High-speed		
31:28	-	-	Reserved	-	-

Table 412. Port states as described by the PE and SUSP bits in the PORTSC1 register

PE bit	SUSP bit	Port state
0	0 or 1	disabled
1	0	enabled
1	1	suspend

23.6.16 OTG Status and Control register (OTGSC)

The OTG register has four sections:

- OTG interrupt enables (R/W)
- OTG Interrupt status (R/WC)
- OTG status inputs (RO)
- OTG controls (R/W)

The status inputs are debounced using a 1 msec time constant. Values on the status inputs that do not persist for more than 1 msec will not cause an update of the status input register or cause an OTG interrupt.

Table 413. OTG Status and Control register (OTGSC - address 0x4000 61A4) bit description

Bit	Symbol	Value	Description	Reset value	Access
0	VD		VBUS_Discharge Setting this bit to 1 causes VBUS to discharge through a resistor.	0	R/W
1	VC		VBUS_Charge Setting this bit to 1 causes the VBUS line to be charged. This is used for VBUS pulsing during SRP.	0	R/W
2	HAAR		Hardware assist auto_reset	0	R/W
		0	Disabled		
		1	Enable automatic reset after connect on host port.		
3	OT		OTG termination This bit must be set to 1 when the OTG controller is in device mode. This controls the pull-down on USB_DM.	0	R/W
4	DP		Data pulsing Setting this bit to 1 causes the pull-up on USB_DP to be asserted for data pulsing during SRP.	0	R/W
5	IDPU		ID pull-up. This bit provides control over the pull-up resistor.	1	R/W
		0	Pull-up off. The ID bit will not be sampled.		
		1	Pull-up on.		
6	HADP		Hardware assist data pulse Write a 1 to start data pulse sequence.	0	R/W
7	HABA		Hardware assist B-disconnect to A-connect	0	R/W
		0	Disabled.		
		1	Enable automatic B-disconnect to A-connect sequence.		
8	ID		USB ID	0	RO
		0	A-device		
		1	B-device		
9	AVV		A-VBUS valid Reading 1 indicates that VBUS is above the A-VBUS valid threshold.	0	RO
10	ASV		A-session valid Reading 1 indicates that VBUS is above the A-session valid threshold.	0	RO
11	BSV		B-session valid Reading 1 indicates that VBUS is above the B-session valid threshold.	0	RO
12	BSE		B-session end Reading 1 indicates that VBUS is below the B-session end threshold.	0	RO
13	MS1T		1 millisecond timer toggle This bit toggles once per millisecond.	0	RO
14	DPS		Data bus pulsing status Reading a 1 indicates that data bus pulsing is detected on the port.	0	RO
15	-	-	Reserved	0	

Table 413. OTG Status and Control register (OTGSC - address 0x4000 61A4) bit description ...continued

Bit	Symbol	Value	Description	Reset value	Access
16	IDIS		USB ID interrupt status This bit is set when a change on the ID input has been detected. Software must write a 1 to this bit to clear it.	0	R/WC
17	AVVIS		A-VBUS valid interrupt status This bit is set then VBUS has either risen above or fallen below the A-VBUS valid threshold (4.4 V on an A-device). Software must write a 1 to this bit to clear it.	0	R/WC
18	ASVIS		A-Session valid interrupt status This bit is set then VBUS has either risen above or fallen below the A-session valid threshold (0.8 V). Software must write a 1 to this bit to clear it.	0	R/WC
19	BSVIS		B-Session valid interrupt status This bit is set then VBUS has either risen above or fallen below the B-session valid threshold (0.8 V). Software must write a 1 to this bit to clear it.	0	R/WC
20	BSEIS		B-Session end interrupt status This bit is set then VBUS has fallen below the B-session end threshold. Software must write a 1 to this bit to clear it.	0	R/WC
21	ms1S		1 millisecond timer interrupt status This bit is set once every millisecond. Software must write a 1 to this bit to clear it.	0	R/WC
22	DPIS		Data pulse interrupt status This bit is set when data bus pulsing occurs on DP or DM. Data bus pulsing is only detected when the CM bit in USBMODE = Host (11) and the PortPower bit in PORTSC = Off (0). Software must write a 1 to this bit to clear it.	0	R/WC
23	-	-	Reserved	0	
24	IDIE		USB ID interrupt enable Setting this bit enables the interrupt. Writing a 0 disables the interrupt.	0	R/W
25	AVVIE		A-VBUS valid interrupt enable Setting this bit enables the A-VBUS valid interrupt. Writing a 0 disables the interrupt.	0	R/W
26	ASVIE		A-session valid interrupt enable Setting this bit enables the A-session valid interrupt. Writing a 0 disables the interrupt	0	R/W
27	BSVIE		B-session valid interrupt enable Setting this bit enables the B-session valid interrupt. Writing a 0 disables the interrupt.	0	R/W
28	BSEIE		B-session end interrupt enable Setting this bit enables the B-session end interrupt. Writing a 0 disables the interrupt.	0	R/W

Table 413. OTG Status and Control register (OTGSC - address 0x4000 61A4) bit description ...continued

Bit	Symbol	Value	Description	Reset value	Access
29	MS1E		1 millisecond timer interrupt enable Setting this bit enables the 1 millisecond timer interrupt. Writing a 0 disables the interrupt.	0	R/W
30	DPIE		Data pulse interrupt enable Setting this bit enables the data pulse interrupt. Writing a 0 disables the interrupt	0	R/W
31	-	-	Reserved	0	-

23.6.17 USB Mode register (USBMODE)

The USBMODE register sets the USB mode for the OTG controller. The possible modes are Device, Host, and Idle mode for OTG operations.

23.6.17.1 Device mode

Table 414. USB Mode register in device mode (USBMODE_D - address 0x4000 61A8) bit description

Bit	Symbol	Value	Description	Reset value	Access
1:0	CM1_0		Controller mode The controller defaults to an idle state and needs to be initialized to the desired operating mode after reset. This register can only be written once after reset. If it is necessary to switch modes, software must reset the controller by writing to the RESET bit in the USBCMD register before reprogramming this register.	00	R/ WO
		0x0	Idle		
		0x1	Reserved		
		0x2	Device controller		
		0x3	Host controller		
2	ES		Endian select This bit can change the byte ordering of the transfer buffers to match the host microprocessor bus architecture. The bit fields in the microprocessor interface and the DMA data structures (including the setup buffer within the device QH) are unaffected by the value of this bit, because they are based upon 32-bit words.	0	R/W
		0	Little endian: first byte referenced in least significant byte of 32-bit word.		
		1	Big endian: first byte referenced in most significant byte of 32-bit word.		
3	SLOM		Setup Lockout mode In device mode, this bit controls behavior of the setup lock mechanism. See Section 23.10.8 .	0	R/W
		0	Setup Lockouts on		
		1	Setup Lockouts Off (DCD requires the use of Setup Buffer Tripwire in USBCMD)		

Table 414. USB Mode register in device mode (USBMODE_D - address 0x4000 61A8) bit description ...continued

Bit	Symbol	Value	Description	Reset value	Access
4	SDIS		Stream disable mode	0	R/W
		0	Enabled. Stream mode enabled.		
		1	Disabled. Stream mode disabled. Setting this bit to one disables double priming on both RX and TX for low bandwidth systems. This mode ensures that when the RX and TX buffers are sufficient to contain an entire packet that the standard double buffering scheme is disabled to prevent overruns/underruns in bandwidth limited systems. Note: In High Speed Mode, all packets received will be responded to with a NYET handshake when stream disable is active.		
5	-		Not used in device mode.	0	-
31:6	-	-	Reserved		

23.6.17.2 Host mode

Table 415. USB Mode register in host mode (USBMODE_H - address 0x4000 61A8) bit description

Bit	Symbol	Value	Description	Reset value	Access
1:0	CM		Controller mode	00	R/ WO
		0x0	Idle		
		0x1	Reserved		
		0x2	Device controller		
		0x3	Host controller		
2	ES		Endian select	0	R/W
		0	Little endian: first byte referenced in least significant byte of 32-bit word.		
		1	Big endian: first byte referenced in most significant byte of 32-bit word.		
3	-		Not used in host mode	0	-

Table 415. USB Mode register in host mode (USBMODE_H - address 0x4000 61A8) bit description ...continued

Bit	Symbol	Value	Description	Reset value	Access
4	SDIS		Stream disable mode	0	R/W
		0	Enabled. Enable stream mode.		
		1	Disabled. Disable stream mode. Setting to a one ensures that overruns/underruns of the latency FIFO are eliminated for low bandwidth systems where the RX and TX buffers are sufficient to contain the entire packet. Disabling stream mode also has the effect of ensuring the TX latency is filled to capacity before the packet is launched onto the USB. Note: Time duration to pre-fill the FIFO becomes significant when stream disable is active. See TXFILLTUNING to characterize the adjustments needed for the scheduler when using this feature.		
5	VBPS		VBUS power select	0	R/WO
		0	vbus_pwr_select is set LOW.		
		1	vbus_pwr_select is set HIGH		
31:6	-	-	Reserved	-	-

23.6.18 USB Endpoint Setup Status register (ENDPSETUPSTAT)

Table 416. USB Endpoint Setup Status register (ENDPTSETUPSTAT - address 0x4000 61AC) bit description

Bit	Symbol	Description	Reset value	Access
5:0	ENDPTSETUPSTAT	Setup endpoint status for logical endpoints 0 to 5. For every setup transaction that is received, a corresponding bit in this register is set to one. Software must clear or acknowledge the setup transfer by writing a one to a respective bit after it has read the setup data from Queue head. The response to a setup packet as in the order of operations and total response time is crucial to limit bus time outs while the setup lockout mechanism is engaged.	0	R/WC
31:6	-	Reserved	-	-

23.6.19 USB Endpoint Prime register (ENDPTPRIME)

For each endpoint, software should write a one to the corresponding bit whenever posting a new transfer descriptor to an endpoint. Hardware will automatically use this bit to begin parsing for a new transfer descriptor from the queue head and prepare a receive buffer. Hardware will clear this bit when the associated endpoint(s) is (are) successfully primed.

Remark: These bits will be momentarily set by hardware during hardware endpoint re-priming operations when a dTD is retired and the dQH is updated.

Table 417. USB Endpoint Prime register (ENDPTPRIME - address 0x4000 61B0) bit description

Bit	Symbol	Description	Reset value	Access
5:0	PERB	<p>Prime endpoint receive buffer for physical OUT endpoints 5 to 0.</p> <p>For each OUT endpoint, a corresponding bit is set to 1 by software to request a buffer be prepared for a receive operation for when a USB host initiates a USB OUT transaction. Software should write a one to the corresponding bit whenever posting a new transfer descriptor to an endpoint. Hardware will automatically use this bit to begin parsing for a new transfer descriptor from the queue head and prepare a receive buffer. Hardware will clear this bit when the associated endpoint(s) is (are) successfully primed.</p> <p>PERB0 = endpoint 0</p> <p>...</p> <p>PERB5 = endpoint 5</p>	0	R/WS
15:6	-	Reserved	-	-
21:16	PETB	<p>Prime endpoint transmit buffer for physical IN endpoints 5 to 0.</p> <p>For each IN endpoint a corresponding bit is set to one by software to request a buffer be prepared for a transmit operation in order to respond to a USB IN/INTERRUPT transaction. Software should write a one to the corresponding bit when posting a new transfer descriptor to an endpoint. Hardware will automatically use this bit to begin parsing for a new transfer descriptor from the queue head and prepare a transmit buffer. Hardware will clear this bit when the associated endpoint(s) is (are) successfully primed.</p> <p>PETB0 = endpoint 0</p> <p>...</p> <p>PETB5 = endpoint 5</p>	0	R/WS
31:22	-	Reserved	-	-

23.6.20 USB Endpoint Flush register (ENDPTFLUSH)

Writing a one to a bit(s) in this register will cause the associated endpoint(s) to clear any primed buffers. If a packet is in progress for one of the associated endpoints, then that transfer will continue until completion. Hardware will clear this register after the endpoint flush operation is successful.

Table 418. USB Endpoint Flush register (ENDPTFLUSH - address 0x4000 61B4) bit description

Bit	Symbol	Description	Reset value	Access
5:0	FERB	<p>Flush endpoint receive buffer for physical OUT endpoints 5 to 0.</p> <p>Writing a one to a bit(s) will clear any primed buffers.</p> <p>FERB0 = endpoint 0</p> <p>...</p> <p>FERB5 = endpoint 5</p>	0	R/WC

Table 418. USB Endpoint Flush register (ENDPTFLUSH - address 0x4000 61B4) bit description

Bit	Symbol	Description	Reset value	Access
15:6	-	Reserved	-	-
21:16	FETB	Flush endpoint transmit buffer for physical IN endpoints 5 to 0. Writing a one to a bit(s) will clear any primed buffers. FETB0 = endpoint 0 ... FETB5 = endpoint 5	0	R/WC
31:22	-	Reserved	-	-

23.6.21 USB Endpoint Status register (ENDPTSTAT)

One bit for each endpoint indicates status of the respective endpoint buffer. This bit is set by hardware as a response to receiving a command from a corresponding bit in the ENDPTPRIME register. There will always be a delay between setting a bit in the ENDPTPRIME register and endpoint indicating ready. This delay time varies based upon the current USB traffic and the number of bits set in the ENDPTPRIME register. Buffer ready is cleared by USB reset, by the USB DMA system, or through the ENDPTFLUSH register.

Remark: These bits will be momentarily cleared by hardware during hardware endpoint re-priming operations when a dTD is retired and the dQH is updated.

Table 419. USB Endpoint Status register (ENDPTSTAT - address 0x4000 61B8) bit description

Bit	Symbol	Description	Reset value	Access
5:0	ERBR	Endpoint receive buffer ready for physical OUT endpoints 5 to 0. This bit is set to 1 by hardware as a response to receiving a command from a corresponding bit in the ENDPTPRIME register. ERBR0 = endpoint 0 ... ERBR5 = endpoint 5	0	RO
15:6	-	Reserved	-	-
21:16	ETBR	Endpoint transmit buffer ready for physical IN endpoints 3 to 0. This bit is set to 1 by hardware as a response to receiving a command from a corresponding bit in the ENDPTPRIME register. ETBR0 = endpoint 0 ... ETBR5 = endpoint 5	0	RO
31:22	-	Reserved	-	-

23.6.22 USB Endpoint Complete register (ENDPTCOMPLETE)

Each bit in this register indicates that a received/transmit event occurred and software should read the corresponding endpoint queue to determine the transfer status. If the corresponding IOC bit is set in the Transfer Descriptor, then this bit will be set simultaneously with the USBINT.

Writing a one will clear the corresponding bit in this register.

Table 420. USB Endpoint Complete register (ENDPTCOMPLETE - address 0x4000 61BC) bit description

Bit	Symbol	Description	Reset value	Access
5:0	ERCE	Endpoint receive complete event for physical OUT endpoints 5 to 0. This bit is set to 1 by hardware when a receive event (OUT) occurred. ERCE0 = endpoint 0 ... ERCE5 = endpoint 5	0	R/WC
15:6	-	Reserved	-	-
21:16	ETCE	Endpoint transmit complete event for physical IN endpoints 5 to 0. This bit is set to 1 by hardware when a transmit event (IN/INTERRUPT) occurred. ETCE0 = endpoint 0 ... ETCE5 = endpoint 5	0	R/WC
31:21	-	Reserved	-	-

23.6.23 USB Endpoint 0 Control register (ENDPTCTRL0)

This register initializes endpoint 0 for control transfer. Endpoint 0 is always a control endpoint.

Table 421. USB Endpoint 0 Control register (ENDPTCTRL0 - address 0x4000 61C0) bit description

Bit	Symbol	Value	Description	Reset value	Access
0	RXS		Rx endpoint stall	0	R/W
		0	Endpoint ok.		
		1	Endpoint stalled Software can write a one to this bit to force the endpoint to return a STALL handshake to the Host. It will continue returning STALL until the bit is cleared by software, or it will automatically be cleared upon receipt of a new SETUP request. After receiving a SETUP request, this bit will continue to be cleared by hardware until the associated ENDSETUPSTAT bit is cleared. [1]		
1	-	-	Reserved		
3:2	RXT1_0		Endpoint type Endpoint 0 is always a control endpoint.	00	R/W
6:4	-	-	Reserved	-	-
7	RXE		Rx endpoint enable Endpoint enabled. Control endpoint 0 is always enabled. This bit is always 1.	1	RO
15:8	-	-	Reserved	-	-

Table 421. USB Endpoint 0 Control register (ENDPTCTRL0 - address 0x4000 61C0) bit description ...continued

Bit	Symbol	Value	Description	Reset value	Access
16	TXS		Tx endpoint stall		R/W
		0	Endpoint ok.		
		1	Endpoint stalled Software can write a one to this bit to force the endpoint to return a STALL handshake to the Host. It will continue returning STALL until the bit is cleared by software, or it will automatically be cleared upon receipt of a new SETUP request. After receiving a SETUP request, this bit will continue to be cleared by hardware until the associated ENDSETUPSTAT bit is cleared. ^[1]		
17	-	-	Reserved		
19:18	TXT1_0		Endpoint type Endpoint 0 is always a control endpoint.	00	RO
22:20	-	-	Reserved		
23	TXE		Tx endpoint enable Endpoint enabled. Control endpoint 0 is always enabled. This bit is always 1.	1	RO
31:24	-	-	Reserved		

[1] There is a slight delay (50 clocks max) between the ENPTSETUPSTAT being cleared and hardware continuing to clear this bit. In most systems it is unlikely that the DCD software will observe this delay. However, should the DCD notice that the stall bit is not set after writing a one to it, software should continually write this stall bit until it is set or until a new setup has been received by checking the associated ENDPTSETUPSTAT bit.

23.6.24 Endpoint 1 to 5 control registers

Each endpoint that is not a control endpoint has its own register to set the endpoint type and enable or disable the endpoint.

Remark: The reset value for all endpoint types is the control endpoint. If one endpoint direction is enabled and the paired endpoint of opposite direction is disabled, then the endpoint type of the unused direction must be changed from the control type to any other type (e.g. bulk). Leaving an unconfigured endpoint control will cause undefined behavior for the data PID tracking on the active endpoint.

Table 422. USB Endpoint 1 to 5 control registers (ENDPTCTRL - address 0x4000 61C4 (ENDPTCTRL1) to 0x4000 61D4 (ENDPTCTRL5)) bit description

Bit	Symbol	Value	Description	Reset value	Access	
0	RXS		Rx endpoint stall	0	R/W	
		0	Endpoint ok. This bit will be cleared automatically upon receipt of a SETUP request if this Endpoint is configured as a Control Endpoint and this bit will continue to be cleared by hardware until the associated ENDPTSETUPSTAT bit is cleared.			
		1	Endpoint stalled Software can write a one to this bit to force the endpoint to return a STALL handshake to the Host. It will continue returning STALL until the bit is cleared by software, or it will automatically be cleared upon receipt of a new SETUP request.			

Table 422. USB Endpoint 1 to 5 control registers (ENDPTCTRL - address 0x4000 61C4 (ENDPTCTRL1) to 0x4000 61D4 (ENDPTCTRL5)) bit description ...continued

Bit	Symbol	Value	Description	Reset value	Access
1	-		Reserved	0	R/W
3:2	RXT		Endpoint type	00	R/W
		0x0	Control		
		0x1	Isochronous		
		0x2	Bulk		
		0x3	Interrupt		
4	-	-	Reserved		
5	RXI		Rx data toggle inhibit	0	R/W
			This bit is only used for test and should always be written as zero. Writing a one to this bit will cause this endpoint to ignore the data toggle sequence and always accept data packets regardless of their data PID.		
		0	Disabled		
		1	Enabled		
6	RXR		Rx data toggle reset	0	WS
			Write 1 to reset the PID sequence.		
			Whenever a configuration event is received for this Endpoint, software must write a one to this bit in order to synchronize the data PIDs between the host and device.		
7	RXE		Rx endpoint enable	0	R/W
			Remark: An endpoint should be enabled only after it has been configured.		
		0	Endpoint disabled.		
		1	Endpoint enabled.		
15:8	-	-	Reserved		
16	TXS		Tx endpoint stall	0	R/W
		0	Endpoint ok.		
			This bit will be cleared automatically upon receipt of a SETUP request if this Endpoint is configured as a Control Endpoint, and this bit will continue to be cleared by hardware until the associated ENDPTSETUPSTAT bit is cleared.		
		1	Endpoint stalled		
			Software can write a one to this bit to force the endpoint to return a STALL handshake to the Host. It will continue returning STALL until the bit is cleared by software, or it will automatically be cleared upon receipt of a new SETUP request.		
17	-	-	Reserved	0	-
19:18	TXT1_0		Tx endpoint type	00	R/W
		0x0	Control		
		0x1	Isochronous		
		0x2	Bulk		
		0x3	Interrupt		
20	-	-	Reserved		

Table 422. USB Endpoint 1 to 5 control registers (ENDPTCTRL - address 0x4000 61C4 (ENDPTCTRL1) to 0x4000 61D4 (ENDPTCTRL5)) bit description ...continued

Bit	Symbol	Value	Description	Reset value	Access
21	TXI		Tx data toggle inhibit	0	R/W
			This bit is only used for test and should always be written as zero. Writing a one to this bit will cause this endpoint to ignore the data toggle sequence and always accept data packets regardless of their data PID.		
		0	Enabled		
		1	Disabled		
22	TXR		Tx data toggle reset	1	WS
			Write 1 to reset the PID sequence.		
			Whenever a configuration event is received for this Endpoint, software must write a one to this bit in order to synchronize the data PID's between the host and device.		
23	TXE		Tx endpoint enable	0	R/W
			Remark: An endpoint should be enabled only after it has been configured		
		0	Endpoint disabled.		
		1	Endpoint enabled.		
31:24	-	-	Reserved	0	

23.7 Functional description

23.7.1 OTG core

The OTG core forms the main digital part of the USB-OTG. See the *USB EHCI specification* for details about this core.

23.7.2 Host data structures

See Chapter 4 of the *USB EHCI Specification for Universal Serial Bus 1.0*.

23.7.3 Host operational model

See Chapter 3 of the *USB EHCI Specification for Universal Serial Bus 1.0*.

23.7.4 ATX_RGEN module

The requirements for the reset signal towards the ATX transceiver are as follows:

- The clocks must be running for a reset to occur correctly.
- The ATX must see a rising edge of reset to correctly reset the clock generation module.
- The reset must be a minimum of 133 ns (4 × 30 MHz clock cycles) in duration to reset all logic correctly.

The ATX_RGEN module generates a reset signal towards the ATX fulfilling above 3 requirements, no matter how the AHB reset looks like.

23.7.5 ATX transceiver

The USB-OTG has a USB transceiver with UTMI+ interface. It contains the required transceiver OTG functionality; this includes:

- VBUS sensing for producing the session-valid and VBUS-valid signals.
- sampling of the USB_ID input for detection of A-device or B-device connection.
- charging and discharging of VBUS for starting and ending a session as B-device.

23.7.6 Modes of operation

In general, the USB-OTG can operate either in host mode or in device mode. Software must put the core in the appropriate mode by setting the USBMODE.CM field ('11' for host mode, '10' for device mode).

The USBMODE.CM field can also be equal to '00', which means that the core is in idle mode (neither host nor device mode). This will happen after the following:

- a hardware reset.
- a software reset via the USBCMD.RST bit. When switching from host mode to device mode as part of the HNP protocol (or vice versa), software must issue a software reset which sets the USB core to the idle state in a time frame dependent on the software.

23.7.7 SOF/VF indicator

See [Section 23.2](#) for connecting the SOF signal to other peripherals on the LPC18xx.

The USB-OTG generates a SOF/VF indicator signal, which can be used by user specific external logic.

In FS mode, the SOF/VF indicator signal has a frequency equal to the frame frequency, which is about 1 kHz. The signal is high for half of the frame period and low for the other half of the frame period. The positive edge is aligned with the start of a frame (= SOF).

In HS mode, the SOF/VF indicator signal has a frequency equal to the virtual frame frequency. The positive edge indicates the start of the Virtual Frame and is aligned with the occurrence of an SOF token on the USB

The length of the virtual frame is defined as: $VF = \text{microframe} \times 2^{bInterval}$

bInterval is specified in the 4-bit programmable BINTERVAL.BINT register field. The minimum value of bInterval is 0, the maximum value is 15.

In suspend mode the SOF/VF indicator signal is turned off (= remains low).

23.7.7.1 SOF frame length adjust

Remark: The SOF frame length adjust is implemented on parts with on-chip flash only.

If the USB is in host mode, the SOF length can be changed dynamically based on the data flow. The frame length adjustment feature is useful when combining the USB with I2S in an audio application where the audio clock is derived from a highly accurate source. In this case, I2S is consuming the buffer at the audio clock rate while the USB is filling the buffer. If software detects that the USB is filling the buffer slowly relative to the I2S

consumption rate, then software can reduce the SOF length using the USB0FLADJ register. The USB bit clock is still running at the normal rate so no bus errors occur. The host only changes when it introduces the next SOF token - earlier or later on a bit-time resolution boundary. Adding the SOF token early allows to obtain more data over the course of the transmission.

The registers to control the frame length are located in the CREG block (see [Table 98](#)).

23.7.8 Hardware assist

The hardware assist provides automated response and sequencing that may not be possible in software if there are significant interrupt latency response times. The use of this additional circuitry is optional and can be used to assist the following three state transitions by setting the appropriate bits in the OTGSC register:

- Auto reset (set bit HAAR).
- Data pulse (set bit HADP).
- B-disconnect to A-connect (set bit HABA).

23.7.8.1 Auto reset

When the HAAR in the OTGSC register is set to one, the host will automatically start a reset after a connect event. This shortcuts the normal process where software is notified of the connect event and starts the reset. Software will still receive notification of the connect event (CCS bit in the PORTSC register) but should not write the reset bit in the USBCMD register when the HAAR is set. Software will be notified again after the reset is complete via the enable change bit in the PORTSC register which causes a port change interrupt.

This assist will ensure the OTG parameter `TB_ACON_BSE0_MAX = 1 ms` is met (see *OTG specification* for an explanation of the OTG timing requirements).

23.7.8.2 Data pulse

Writing a one to HADP in the OTGSC register will start a data pulse of approximately 7 ms in duration and then automatically cease the data pulsing. During the data pulse, the DP bit will be set and then cleared. This automation relieves software from accurately controlling the data-pulse duration. During the data pulse, the HCD can poll to see that the HADP and DP bit have returned low to recognize the completion, or the HCD can simply launch the data pulse and wait to see if a VBUS Valid interrupt occurs when the A-side supplies bus power.

This assist will ensure data pulsing meets the OTG requirement of > 5 ms and < 10 ms.

23.7.8.3 B-disconnect to A-connect (Transition to the A-peripheral state)

During HNP, the B-disconnect occurs from the OTG A_suspend state, and within 3 ms, the A-device must enable the pull-up on the DP leg in the A-peripheral state. For the hardware assist to begin the following conditions must be met:

- HABA is set.
- Host controller is in suspend mode.
- Device is disconnecting.

The hardware assist consists of the following steps:

1. Hardware resets the OTG controller (writes 1 to the RST bit in USBCMD).
2. Hardware selects the device mode (writes 10 to bits CM[1:0] in USBMODE).
3. Hardware sets the RS bit in USBCMD and enables the necessary interrupts:
 - USB reset enable (URE) - enables interrupt on USB bus reset to device.
 - Sleep enable (SLE) - enables interrupt on device suspend.
 - Port change detect enable (PCE) - enables interrupt on device connect.

When software has enabled this hardware assist, it must not interfere during the transition and should not write any register in the OTG core until it gets an interrupt from the device controller signifying that a reset interrupt has occurred or until it has verified that the core has entered device mode. HCD/DCD must not activate the core soft reset at any time since this action is performed by hardware. During the transition, the software may see an interrupt from the disconnect and/or other spurious interrupts (i.e. SOF/etc.) that may or may not cascade and may be cleared by the soft reset depending on the software response time.

After the core has entered device mode with help of the hardware assist, the DCD must ensure that the ENDPTLISTADDR is programmed properly before the host sends a setup packet. Since the end of the reset duration, which may be initiated quickly (a few microseconds) after connect, will require at a minimum 50 ms, this is the time for which the DCD must be ready to accept setup packets after having received notification that the reset has been detected or simply that the OTG is in device mode which ever occurs first.

If the A-peripheral fails to see a reset after the controller enters device mode and engages the D+-pull-up, the device controller interrupts the DCD signifying that a suspend has occurred. This assist will ensure the parameter TA_BDIS_ACON_MAX = 3ms is met.

23.8 Deviations from EHCI standard

For the purposes of a dual-role Host/Device controller with support for On-The-Go applications, it is necessary to deviate from the EHCI specification. Device operation and On-The-Go operation is not specified in the EHCI and thus the implementation supported in this core is specific to the LPC18xx. The host mode operation of the core is near EHCI compatible with few minor differences documented in this section.

The particulars of the deviations occur in the areas summarized here:

- Embedded Transaction Translator – Allows direct attachment of FS and LS devices in host mode without the need for a companion controller.
- Device operation - In host mode the device operational registers are generally disabled and thus device mode is mostly transparent when in host mode. However, there are a couple exceptions documented in the following sections.
- On-The-Go Operation - This design includes an On-The-Go controller.

23.8.1 Embedded Transaction Translator function

The USB-HS OTG controller supports directly connected full and low speed devices without requiring a companion controller by including the capabilities of a USB 2.0 high speed hub transaction translator. Although there is no separate Transaction Translator

block in the system, the transaction translator function normally associated with a high speed hub has been implemented within the DMA and Protocol engine blocks. The embedded transaction translator function is an extension to EHCI interface but makes use of the standard data structures and operational models that exist in the EHCI specification to support full and low speed devices.

23.8.1.1 Capability registers

The following items have been added to the capability registers to support the embedded Transaction Translator Function:

- N_TT bits added to HCSPARAMS – Host Control Structural Parameters (see [Table 386](#)).
- N_PTT added to HCSPARAMS – Host Control Structural Parameters (see [Table 386](#)).

23.8.1.2 Operational registers

The following items have been added to the operational registers to support the embedded TT:

- New register TTCTRL (see [Section 23.6.9](#)).
- Two-bit Port Speed (PSPD) bits added to the PORTSC1 register (see [Section 23.6.15](#)).

23.8.1.3 Discovery

In a standard EHCI controller design, the EHCI host controller driver detects a Full speed (FS) or Low speed (LS) device by noting if the port enable bit is set after the port reset operation. The port enable will only be set in a standard EHCI controller implementation after the port reset operation and when the host and device negotiate a High-Speed connection (i.e. Chirp completes successfully). Since this controller has an embedded Transaction Translator, the port enable will always be set after the port reset operation regardless of the result of the host device chirp result and the resulting port speed will be indicated by the PSPD field in PORTSC1 (see [Section 23.6.15](#)).

Table 423. Handling of directly connected full-speed and low-speed devices

Standard EHCI model	EHCI with embedded Transaction Translator
After the port enable bit is set following a connection and reset sequence, the device/hub is assumed to be HS.	After the port enable bit is set following a connection and reset sequence, the device/hub speed is noted from PORTSC1.
FS and LS devices are assumed to be downstream from a HS hub thus, all port-level control is performed through the Hub Class to the nearest Hub.	FS and LS device can be either downstream from a HS hub or directly attached. When the FS/LS device is downstream from a HS hub, then port-level control is done using the Hub Class through the nearest Hub. When a FS/LS device is directly attached, then port-level control is accomplished using PORTSC1.
FS and LS devices are assumed to be downstream from a HS hub with HubAddr=X, where HubAddr > 0 and HubAddr is the address of the Hub where the bus transitions from HS to FS/LS (i.e. Split target hub).	FS and LS device can be either downstream from a HS hub with HubAddr = X [HubAddr > 0] or directly attached, where HubAddr = TTHA (TTHA is programmable and defaults to 0) and HubAddr is the address of the Root Hub where the bus transitions from HS to FS/LS (i.e. Split target hub is the root hub).

23.8.1.4 Data structures

The same data structures used for FS/LS transactions through a HS hub are also used for transactions through the Root Hub with an embedded Transaction Translator. Here it is demonstrated how the Hub Address and Endpoint Speed fields should be set for directly attached FS/LS devices and hubs:

1. QH (for directly attached FS/LS device) – Async. (Bulk/Control Endpoints) Periodic (Interrupt)

- Hub Address = TTHA (default TTHA = 0)
- Transactions to directly attached device/hub: QH.EPS = Port Speed
- Transactions to a device downstream from directly attached FS hub: QH.EPS = Downstream Device Speed

Remark: When QH.EPS = 01 (LS) and PORTSC1.PSPD = 00 (FS), a LS-pre-pid will be sent before transmitting the LS traffic.

Maximum Packet Size must be less than or equal to 64 or undefined behavior may result.

2. siTD (for directly attached FS device) – Periodic (ISO Endpoint)

all FS ISO transactions:

Hub Address = (default TTHA = 0)

siTD.EPS = 00 (full speed)

Maximum Packet Size must be less than or equal to 1023 or undefined behavior may result.

23.8.1.5 Operational model

The operational models are well defined for the behavior of the Transaction Translator (see USB 2.0 specification) and for the EHCI controller moving packets between system memory and a USB-HS hub. Since the embedded Transaction Translator exists within the host controller there is no physical bus between the EHCI host controller driver and the USB FS/LS bus. These sections will briefly discuss the operational model for how the EHCI and Transaction Translator operational models are combined without the physical bus between them. The following sections assume the reader is familiar with both the EHCI and USB 2.0 Transaction Translator operational models.

23.8.1.5.1 Micro-frame pipeline

The EHCI operational model uses the concept of H-frames and B-frames to describe the pipeline between the Host (H) and the Bus (B). The embedded Transaction Translator shall use the same pipeline algorithms specified in the USB 2.0 specification for a Hub-based Transaction Translator.

It is important to note that when programming the S-mask and C-masks in the EHCI data structures to schedule periodic transfers for the embedded Transaction Translator, the EHCI host controller driver must follow the same rules specified in EHCI for programming the S-mask and C-mask for downstream Hub-based Transaction Translators. Once periodic transfers are exhausted, any stored asynchronous transfer will be moved. Asynchronous transfers are opportunistic in that they shall execute whenever possible and their operation is not tied to H-frame and B-frame boundaries with the exception that an asynchronous transfer can not babble through the SOF (start of B-frame 0.)

23.8.1.6 Split state machines

The start and complete split operational model differs from EHCI slightly because there is no bus medium between the EHCI controller and the embedded Transaction Translator. Where a start or complete-split operation would occur by requesting the split to the HS hub, the start/complete split operation is simply an internal operation to the embedded Transaction Translator. The following table summarizes the conditions where handshakes are emulated from internal state instead of actual handshakes to HS split bus traffic.

Table 424. Split state machine properties

	Condition	Emulate TT response
Start-split	All asynchronous buffers full.	NAK
	All periodic buffers full.	ERR
	Success for start of Async. Transaction.	ACK
	Start Periodic Transaction.	No Handshake (Ok)
Complete-split	Failed to find transaction in queue.	Bus Time Out
	Transaction in Queue is Busy.	NYET
	Transaction in Queue is Complete.	[Actual Handshake from LS/FS device]

23.8.1.7 Asynchronous Transaction scheduling and buffer management

The following USB 2.0 specification items are implemented in the embedded Transaction Translator:

1. *USB 2.0 specification, section 11.17.3*: Sequencing is provided & a packet length estimator ensures no full-speed/low-speed packet babbles into SOF time.
2. *USB 2.0 specification, section 11.17.4*: Transaction tracking for 2 data pipes.
3. *USB 2.0 specification, section 11.17.5*: Clear_TT_Buffer capability provided though the use of the TTCTRL register.

23.8.1.8 Periodic Transaction scheduling and buffer management

The following USB 2.0 specification items are implemented in the embedded Transaction Translator:

1. *USB 2.0 specs, section 11.18.6.[1-2]*:
 - Abort of pending start-splits:
 - EOF (and not started in micro-frames 6)
 - Idle for more than 4 micro-frames
 - Abort of pending complete-splits:
 - EOF
 - Idle for more than 4 micro-frames
2. *USB 2.0 specs, section 11.18.6.[7-8]*:
 - Transaction tracking for up to 16 data pipes:
 - Complete-split transaction searching:

There is no data schedule mechanism for these transactions other than micro-frame pipeline. The embedded TT assumes the number of packets scheduled in a frame does not exceed the frame duration (1 ms) or else undefined behavior may result.

23.8.1.9 Multiple Transaction Translators

The maximum number of embedded Transaction Translators that is currently supported is one as indicated by the N_TT field in the HCSPARAMS – Host Control Structural Parameters register.

23.8.2 Device operation

The co-existence of a device operational controller within the host controller has little effect on EHCI compatibility for host operation except as noted in this section.

23.8.2.1 USBMODE register

Given that the dual-role controller is initialized in neither host nor device mode, the USBMODE register must be programmed for host operation before the EHCI host controller driver can begin EHCI host operations.

23.8.2.2 Non-Zero register fields

Some of the reserved fields and reserved addresses in the capability registers and operational register are used in device mode. For read and write operations to these register, note the following:

- Always write zero to all EHCI reserved fields (some of which are device fields). This is an EHCI requirement of the device controller driver.
- Read operations by the host controller must properly mask EHCI reserved fields (some of which are device fields) because fields that are used exclusively in device mode are undefined in host mode.

23.8.2.3 SOF interrupt

This SOF Interrupt used for device mode is also used in host mode. In host mode, this interrupt is raised every 125 μ s (high-speed mode). EHCI does not specify this interrupt but it has been added for convenience and as a potential software time base. See USBSTS ([Section 23.6.4](#)) and USBINTR ([Section 23.6.5](#)) registers.

23.8.3 Deviations from EHCI

23.8.3.1 Discovery

23.8.3.1.1 Port reset

The port connect methods specified by EHCI require setting the port reset bit in the PORTSC1 register for a duration of 10 ms. Due to the complexity required to support the attachment of devices that are not high speed, there are counters already present in the design that can count the 10 ms reset pulse to alleviate the burden on the software to measure this duration. The basic connection is summarized as follows:

- [Port Change Interrupt] Port connect change occurs to notify the host controller driver that a device has attached.

- Software writes a '1' to the port reset bit in the PORTSC1 register to reset the device.
- Software writes a '0' to the port reset bit in the PORTSC1 register after 10 ms.
This step, which is necessary in a standard EHCI design, may be omitted with this implementation. Should the EHCI host controller driver attempt to write a '0' to the port reset bit while a reset is in progress, the write will simply be ignored, and the reset will continue until completion.
- [Port Change Interrupt] Port enable change occurs to notify the host controller that the device is now operational, and at this point the port speed has been determined.

23.8.3.1.2 Port speed detection

After the port change interrupt indicates that a port is enabled, the EHCI stack should determine the port speed. Unlike the EHCI implementation which will re-assign the port owner for any device that does not connect at High-Speed, this host controller supports direct-attach of non High-Speed devices. Therefore, the following differences are important regarding port speed detection:

- Port Owner is read-only and always reads 0.
- A 2-bit Port Speed indicator has been added to the PORTSC1 register to provide the current operating speed of the port to the host controller driver.
- A 1-bit High Speed indicator has been added to the PORTSC1 register to indicate that the port is in High-Speed vs. Full/Low Speed – This information is redundant with the 2-bit Port Speed indicator above.

23.9 Device data structures

This section defines the interface data structures used to communicate control, status, and data between Device Controller Driver (DCD) Software and the device controller. The data structure definitions in this chapter support a 32-bit memory buffer address space.

Remark: The software must ensure that no interface data structure reachable by the Device controller crosses a 4kB-page boundary.

The data structures defined in the chapter are (from the device controller's perspective) a mix of read-only and read/ writable fields. The DCD must preserve the read-only fields on all data structure writes.

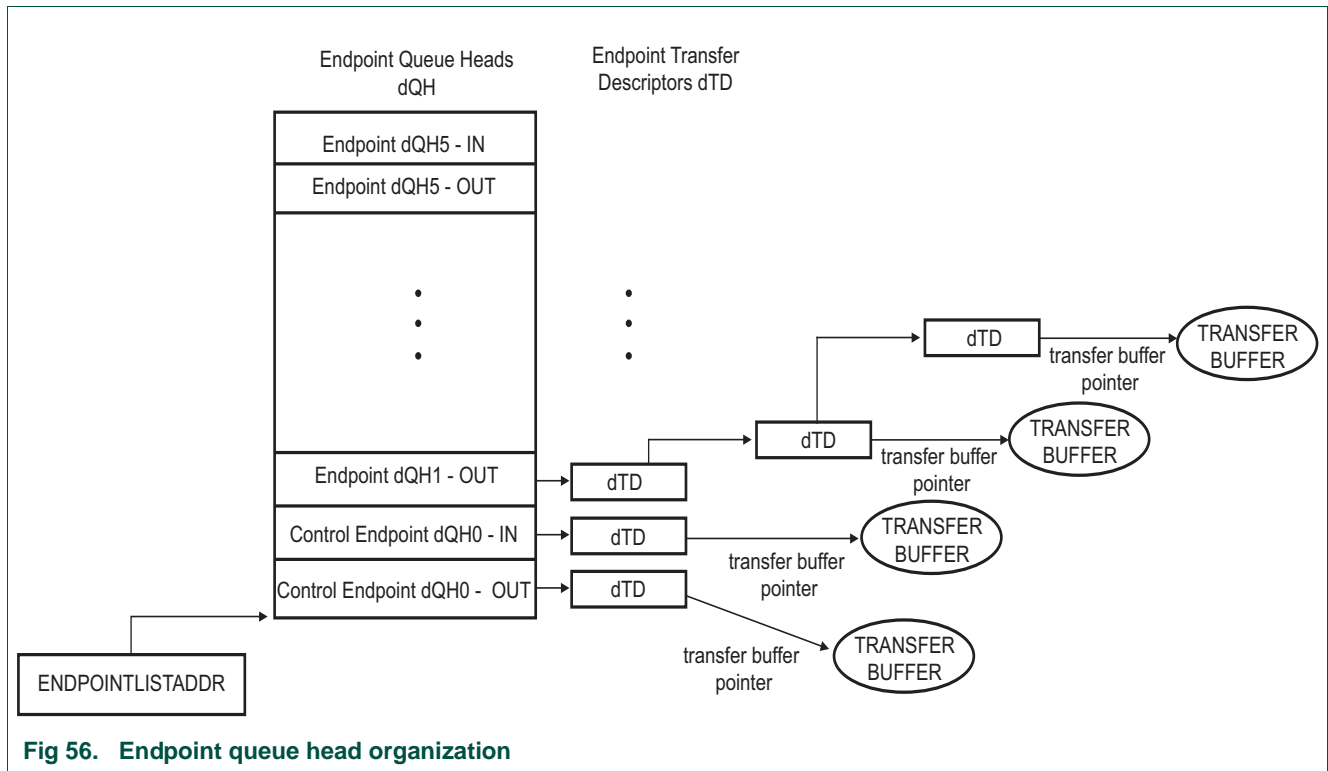

Fig 56. Endpoint queue head organization

Device queue heads are arranged in an array in a continuous area of memory pointed to by the ENDPOINTLISTADDR pointer. The even device queue heads in the list are used for receive endpoints (OUT) and the odd-numbered queue heads in the list are used for transmit endpoints (IN). The device controller will index into this array based upon the endpoint number in the USB request. All information necessary to respond to transactions for all primed transfers is contained in this list so the device controller can readily respond to incoming requests without having to traverse a linked list.

Remark: The Endpoint Queue Head List must be aligned to a 2 kB boundary.

23.9.1 Endpoint queue head (dQH)

The device Endpoint Queue Head (dQH) is where all transfers are managed. The dQH is a 48-byte data structure but must be aligned on 64-byte boundaries. During priming of an endpoint, the dTD (device transfer descriptor) is copied into the overlay area of the dQH (see Figure 57), which starts at the nextTD pointer DWord and continues through the end of the buffer pointers DWords. After a transfer is complete, the dTD status DWord is updated in the dTD pointed to by the currentTD pointer. While a packet is in progress, the overlay area of the dQH is used as a staging area for the dTD so that the device controller can access needed information with minimal latency.

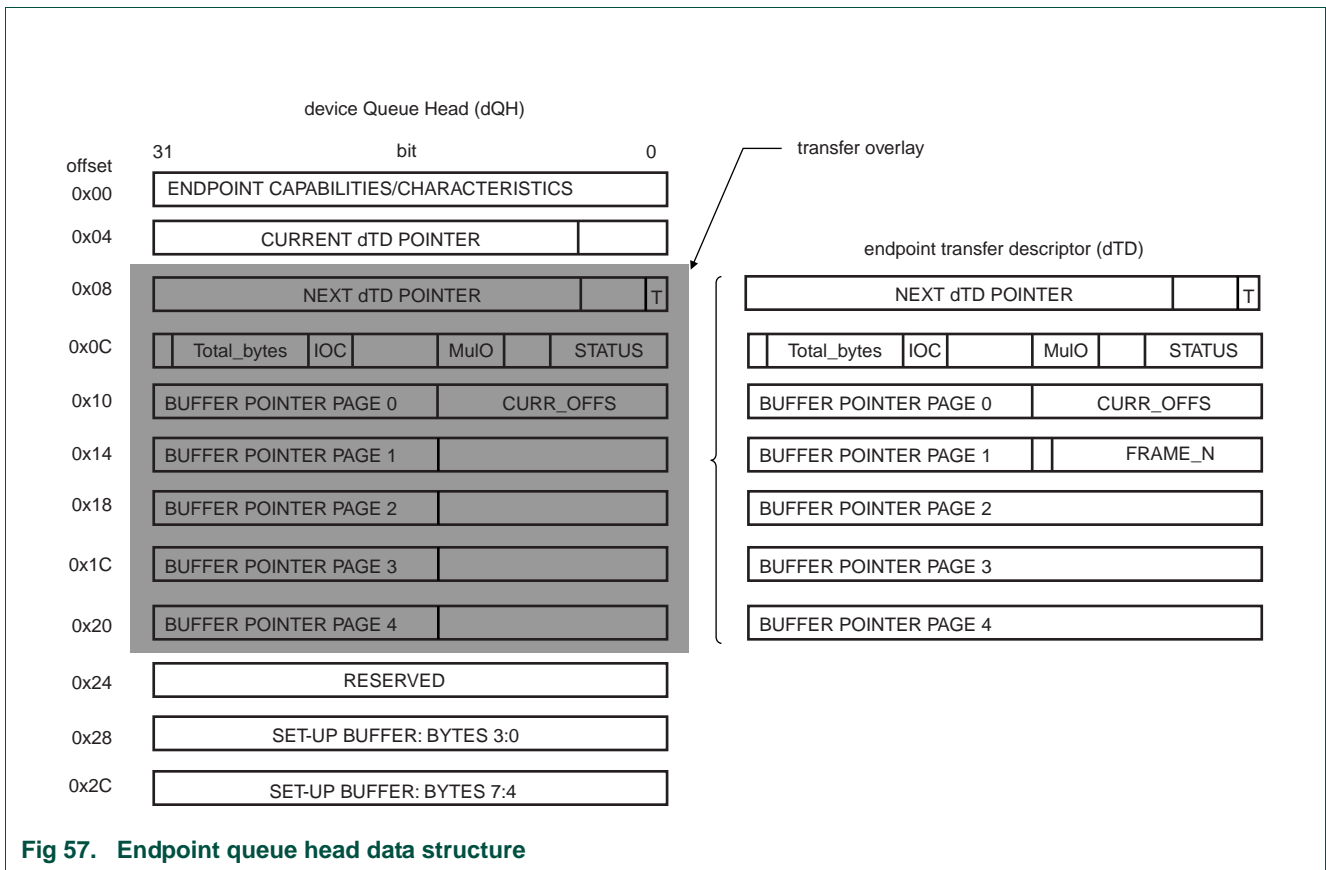

Fig 57. Endpoint queue head data structure

23.9.1.1 Endpoint capabilities and characteristics descriptor fields

This DWord specifies static information about the endpoint, in other words, this information does not change over the lifetime of the endpoint. The device controller software should not attempt to modify this information while the corresponding endpoint is enabled.

Table 425. Endpoint capabilities and characteristics

Access [1]	Bit	Name	Description
RO	31:30	MULT	Number of packets executed per transaction descriptor 00 - Execute N transactions as demonstrated by the USB variable length protocol where N is computed using Max_packet_length and the Total_bytes field in the dTD. 01 - Execute one transaction 10 - Execute two transactions 11 - Execute three transactions Remark: Non-isochronous endpoints must set MULT = 00. Remark: Isochronous endpoints must set MULT = 01, 10, or 11 as needed.
RO	29	ZLT	Zero length termination select This bit is used for non-isochronous endpoints to indicate when a zero-length packet is received to terminate transfers in case the total transfer length is "multiple". 0 - Enable zero-length packet to terminate transfers equal to a multiple of Max_packet_length (default). 1 - Disable zero-length packet on transfers that are equal in length to a multiple Max_packet_length.
RO	28:27	-	reserved
RO	26:16	MAX_PACKET_LENGTH	Maximum packet size of the associated endpoint (<= 1024)
RO	15	IOS	Interrupt on setup This bit is used on control type endpoints to indicate if USBINT is set in response to a setup being received.
RO	14:0	-	reserved

[1] Access indicates in which way a field is accessed by the DMA controller. Software can read or write any of the RO fields.

23.9.1.2 Current dTD pointer descriptor fields

The current dTD pointer is used by the device controller to locate the transfer in progress. This word is for device controller (hardware) use only and should not be modified by DCD software.

Table 426. Current dTD pointer

Access	Bit	Name	Description
R/W (hardware only)	31:5	Current_TD_pointer	Current dTD pointer This field is a pointer to the dTD that is represented in the transfer overlay area. This field will be modified by the device controller to the next dTD pointer during endpoint priming or queue advance.
-	4:0	-	reserved

23.9.1.3 Transfer overlay descriptor fields

The seven DWords in the overlay area represent a transaction working space for the device controller. The general operational model is that the device controller can detect whether the overlay area contains a description of an active transfer. If it does not contain an active transfer, then it will not read the associated endpoint.

After an endpoint is readied, the dTD will be copied into this queue head overlay area by the device controller. Until a transfer is expired, software must not write the queue head overlay area or the associated transfer descriptor. When the transfer is complete, the device controller will write the results back to the original transfer descriptor and advance the queue. See dTD for a description of the overlay fields.

23.9.1.4 Set-up buffer descriptor fields

The set-up buffer is dedicated storage for the 8-byte data that follows a set-up PID.

Remark: Each endpoint has a TX and an RX dQH associated with it, and only the RX queue head is used for receiving setup data packets.

Table 427. Set-up buffer

Dword	Access	Bit	Name	Description
1	R/W	31:0	BUF0	Setup buffer 0 This buffer contains bytes 3 to 0 of an incoming setup buffer packet and is written by the device controller to be read by software.
2	R/W	31:0	BUF1	Setup buffer 1 This buffer contains bytes 7 to 4 of an incoming setup buffer packet and is written by the device controller to be read by software.

23.9.2 Endpoint transfer descriptor (dTD)

The dTD describes to the device controller the location and quantity of data to be sent/received for a given transfer. The DCD should not attempt to modify any field in an active dTD except the Next Link Pointer, which should only be modified as described in [Section 23.10.11](#).

Table 428. Next dTD pointer

Access	Bit	Name	Description
RO	31:5	Next_link_pointer	Next link pointer This field contains the physical memory address of the next dTD to be processed. The field corresponds to memory address signals [31:5], respectively.
	4:1	-	reserved
	0	T	Terminate This bit indicates to the device controller when there are no more valid entries in the queue. 1 - pointer is invalid 0 - Pointer is valid, i.e. pointer points to a valid transfer element descriptor.

Table 429. dTD token

Access ^[1]	Bit	Name	Description
-	31	-	reserved
R/W	30:16	Total_bytes	<p>Total bytes</p> <p>This field specifies the total number of bytes to be moved with this transfer descriptor. This field is decremented by the number of bytes actually moved during the transaction and it is decremented only when the transaction has been completed successfully.</p> <p>The maximum value software can write into this field is 0x5000 (5 x 4 kB) for the maximum number of bytes five page pointers can access. Although it is possible to create a transfer up to 20 kB this assumes that the first offset into the first page is zero. When the offset cannot be predetermined, crossing past the fifth page can be guaranteed by limiting the total bytes to 16 kB. Therefore, the maximum recommended Total-Bytes = 16 kB (0x4000).</p> <p>If Total_bytes = 0 when the host controller fetches this transfer descriptor and the active bit is set in the Status field of this dTD, the device controller executes a zero-length transaction and retires the dTD.</p> <p>Remark: For IN transfers, it is not a requirement that Total_bytes is an even multiple of Max_packet_length. If software builds such a dTD, the last transaction will always be less than Max_packet_length.</p>
RO	15	IOC	<p>Interrupt on complete</p> <p>This bit is used to indicate if USBINT will be set when the device controller is finished with this dTD.</p> <p>1 - USBINT set. 0 - USBINT not set.</p>
-	14:12	-	reserved
RO	11:10	MultO	<p>Multiplier Override (see Section 23.9.2.1 for an example)</p> <p>This field can be used for transmit ISOs to override the MULT field in the dQH. This field must be zero for all packet types that are not transmit-ISO.</p> <p>00 - Execute N transactions as demonstrated by the USB variable length protocol where N is computed using Max_packet_length and the Total_bytes field in the dTD. 01 - Execute one transaction 10 - Execute two transactions 11 - Execute three transactions</p> <p>Remark: Non-ISO and Non-TX endpoints must set MultO="00".</p>
	9:8	-	reserved
R/W	7:0	Status	<p>Status</p> <p>This field is used by the device controller to communicate individual execution states back to the software. This field contains the status of the last transaction performed on this dTD.</p> <p>Bit 7 = 1 - status: Active Bit 6 = 1 - status: Halted Bit 5 = 1 - status: Buffer Error Bit 4 - reserved Bit 3 = 1 - status: Transaction Error Bit 2 - reserved Bit 1 - reserved Bit 0 - reserved</p>

[1] Access indicates in which way a field is accessed by the DMA controller. Software can read or write any of the RO fields.

Table 430. dTD buffer page pointer list

Access	Bit	Name	Description
RO	31:12	BUFF_P	Selects the page offset in memory for the packet buffer. Non-virtual memory systems will typically set the buffer pointers to a series of incrementing integers.
	page 0: 11:0	CURR_OFFS	Offset into the 4 kB buffer where the packet is to begin.
	page 1: 10:0	FRAME_N	Written by the device controller to indicate the frame number in which a packet finishes. This is typically used to correlate relative completion times of packets on an isochronous endpoint.

23.9.2.1 Determining the number of packets for Isochronous IN endpoints

The following examples show how the MULT field in the dQH and the MultO in the dTD are used to control the number of packets sent in an In-transaction for an isochronous endpoint:

Example 1

MULT = 3; Max_packet_size = 8; Total_bytes = 15; MultO = 0 (default)

In this case three packets are sent: Data2 (8 bytes), Data1 (7 bytes), Data0 (0 bytes).

Example 2

MULT = 3; Max_packet_size = 8; Total_bytes = 15; MultO = 2

In this case two packets are sent: Data1 (8 bytes), Data0 (7 bytes).

To optimize efficiency for IN transfers, software should compute MultO = greatest integer of (Total_bytes/Max_packet_size). If Total_bytes = 0, then MultO should be 1.

23.10 Device operational model

The function of the device operation is to transfer a request in the memory image to and from the Universal Serial Bus. Using a set of linked list transfer descriptors, pointed to by a queue head, the device controller will perform the data transfers. The following sections explain the use of the device controller from the device controller driver (DCD) point-of-view and further describe how specific USB bus events relate to status changes in the device controller programmer's interface.

23.10.1 Device controller initialization

After hardware reset, the device is disabled until the Run/Stop bit is set to a '1'. In the Disabled state, the pull-up on the USB_DM is not active which prevents an attach event from occurring. At a minimum, it is necessary to have the queue heads setup for endpoint zero before the device attach occurs. Shortly after the device is enabled, a USB reset will occur followed by a setup packet arriving at endpoint 0. A Queue head must be prepared so that the device controller can store the incoming setup packet.

In order to initialize a device, the software should perform the following steps:

1. Set Controller Mode in the USBMODE register to device mode.

Remark: Transitioning from host mode to device mode requires a device controller reset before modifying USBMODE.

2. Allocate and Initialize device queue heads in system memory (see [Section 23.9](#)).

Minimum: Initialize device queue heads 0 Tx & 0 Rx.

Remark: All device queue heads associated with control endpoints must be initialized before the control endpoint is enabled. Non-Control device queue heads must be initialized before the endpoint is used and not necessarily before the endpoint is enabled.

3. Configure ENDPOINTLISTADDR Pointer (see [Section 23.6.8](#)).
4. Enable the microprocessor interrupt associated with the USB-HS core.

Recommended: enable all device interrupts including: USBINT, USBERRINT, Port Change Detect, USB Reset Received, DCSuspend (see [Table 395](#)).

5. Set Run/Stop bit to Run Mode.

After the Run bit is set, a device reset will occur. The DCD must monitor the reset event and adjust the software state as described in the Bus Reset section of the Port State and Control section (see [Section 23.10.2](#)).

Remark: Endpoint 0 is designed as a control endpoint only and does not need to be configured using ENDPTCTRL0 register.

It is also not necessary to initially prime Endpoint 0 because the first packet received will always be a setup packet. The contents of the first setup packet will require a response in accordance with USB device framework command set (see *USB Specification Rev. 2.0, chapter 9*).

23.10.2 Port state and control

From a chip or system reset, the device controller enters the Powered state. A transition from the Powered state to the Attached state occurs when the Run/Stop bit is set to a '1'. After receiving a reset on the bus, the port will enter the defaultFS or defaultHS state in accordance with the reset protocol described in *Appendix C.2 of the USB Specification Rev. 2.0*. The following state diagram depicts the state of a USB 2.0 device.

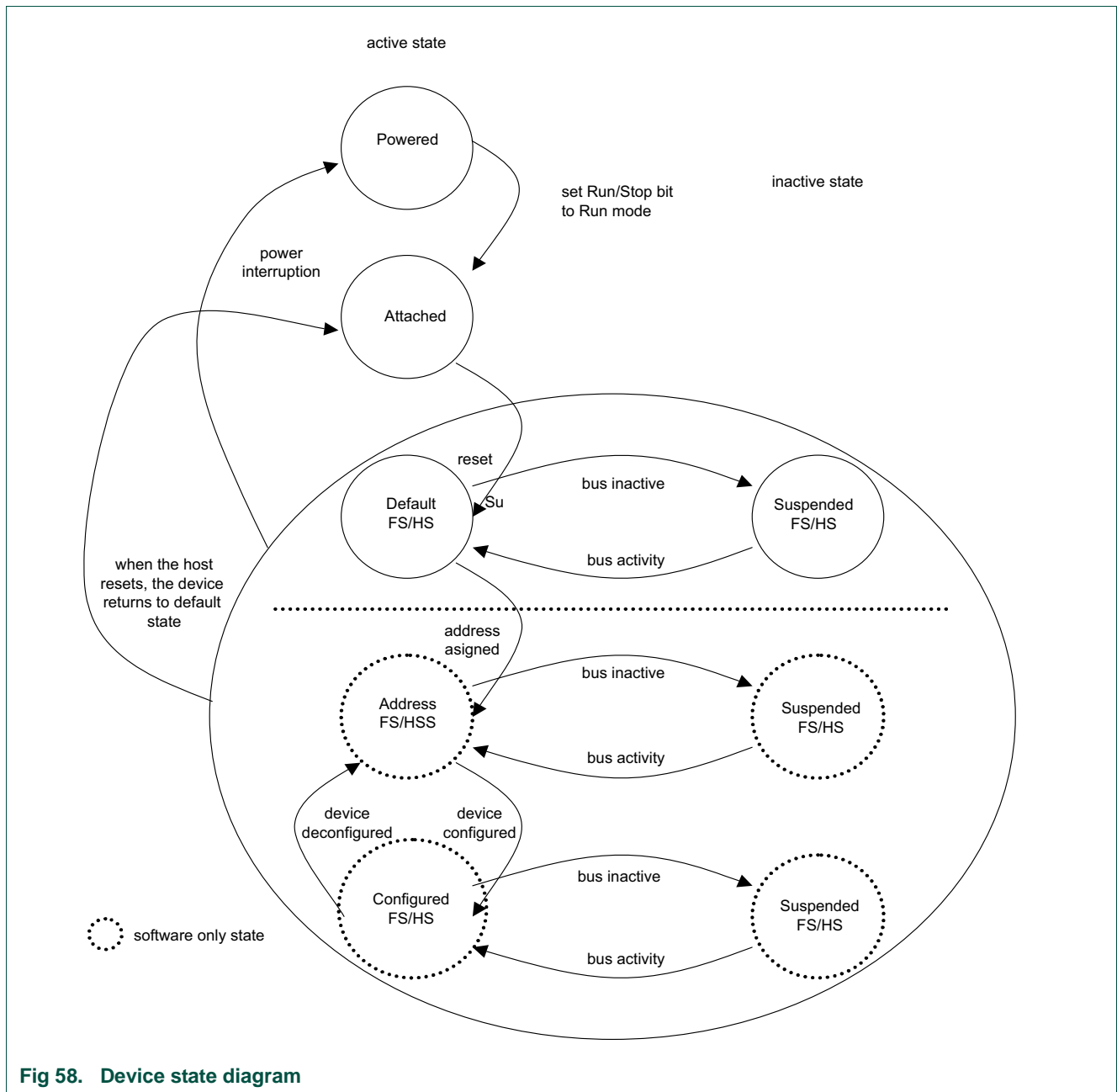

The states powered, attach, default FS/HS, suspend FS/HS are implemented in the device controller and are communicated to the DCD using the following status bits:

- DCSuspend - see [Table 393](#).
- USB reset received - see [Table 393](#).
- Port change detect - see [Table 393](#).
- High-speed port - see [Table 410](#).

It is the responsibility of the DCD to maintain a state variable to differentiate between the DefaultFS/HS state and the Address/Configured states. Change of state from Default to Address and the configured states is part of the enumeration process described in the *Device Framework section of the USB 2.0 Specification*.

As a result of entering the Address state, the device address register (DEVICEADDR) must be programmed by the DCD.

Entry into the Configured state indicates that all endpoints to be used in the operation of the device have been properly initialized by programming the ENDPTCTRLx registers and initializing the associated queue heads.

23.10.3 Bus reset

A bus reset is used by the host to initialize downstream devices. When a bus reset is detected, the device controller will renegotiate its attachment speed, reset the device address to 0, and notify the DCD by interrupt (assuming the USB Reset Interrupt Enable is set). After a reset is received, all endpoints (except endpoint 0) are disabled and any primed transactions will be cancelled by the device controller. The concept of priming will be clarified below, but the DCD must perform the following tasks when a reset is received:

- Clear all setup token semaphores by reading the ENDPTSETUPSTAT register and writing the same value back to the ENDPTSETUPSTAT register.
- Clear all the endpoint complete status bits by reading the ENDPTCOMPLETE register and writing the same value back to the ENDPTCOMPLETE register.
- Cancel all primed status by waiting until all bits in the ENDPTPRIME register are 0 and then writing 0xFFFFFFFF to the ENDPTFLUSH register.
- Read the reset bit in the PORTSC1 register and make sure that it is still active. A USB reset will occur for a minimum of 3 ms and the DCD must reach this point in the reset cleanup before end of the reset occurs, otherwise a hardware reset of the device controller is recommended (rare).

Remark: A hardware reset can be performed by writing a one to the device controller reset bit in the USBCMD register. A hardware reset will cause the device to detach from the bus by clearing the Run/Stop bit. Thus, the DCD must completely re-initialize the device controller after a hardware reset.

- Free all allocated dTDs because they will no longer be executed by the device controller. If this is the first time the DCD is processing a USB reset event, then it is likely that no dTDs have been allocated. At this time, the DCD may release control back to the OS because no further changes to the device controller are permitted until a Port Change Detect is indicated.
- After a Port Change Detect, the device has reached the default state and the DCD can read the PORTSC1 to determine if the device is operating in FS or HS mode. At this time, the device controller has reached normal operating mode and DCD can begin enumeration according to the *USB2.0 specification Chapter 9 - Device Framework*.

Remark: The device DCD may use the FS/HS mode information to determine the bandwidth mode of the device.

In some applications, it may not be possible to enable one or more pipes while in FS mode. Beyond the data rate issue, there is no difference in DCD operation between FS and HS modes.

23.10.4 Suspend/resume

23.10.4.1 Suspend

In order to conserve power, USB devices automatically enter the Suspended state when the device has observed no bus traffic for a specified period. When suspended, the USB device maintains any internal status, including its address and configuration. Attached devices must be prepared to suspend any time they are in the Default, Address, or Configured state. Bus activity may cease due to the host entering a suspend mode of its own. In addition, a USB device shall also enter the suspended state when the hub port it is attached to is disabled.

A USB device exits suspend mode when there is bus activity. A USB device may also request the host to exit suspend mode or selective suspend by using electrical signaling to indicate remote wake-up. The ability of a device to signal remote wake-up is optional. If the USB device is capable of remote wake-up signaling, the device must support the ability of the host to enable and disable this capability. When the device is reset, remote wake-up signaling must be disabled.

23.10.4.1.1 Operational model

The device controller moves into the Suspended state when suspend signaling is detected or activity is missing on the upstream port for more than a specific period. After the device controller enters the Suspended state, the DCD is notified by an interrupt (assuming DC Suspend Interrupt is enabled). When the DCSuspend bit in the PORTSC1 is set to a '1', the device controller is suspended.

DCD response when the device controller is suspended is application specific and may involve switching to low power operation. Information on the bus power limits in the Suspended state can be found in *USB 2.0 specification*.

23.10.4.2 Resume

If the device controller is suspended, its operation is resumed when any non-idle signaling is received on its upstream facing port. In addition, the device can signal the system to resume operation by forcing resume signaling to the upstream port. Resume signaling is sent upstream by writing a '1' to the Resume bit in the in the PORTSC1 while the device is in the Suspended state. Sending resume signal to an upstream port should cause the host to issue resume signaling and bring the suspended bus segment (one or more devices) back to the active condition.

Remark: Before resume signaling can be used, the host must enable it by using the Set Feature command defined in *USB Device Framework (chapter 9) of the USB 2.0 Specification*.

23.10.5 Managing endpoints

The *USB 2.0 specification* defines an endpoint, also called a device endpoint or an address endpoint as a uniquely addressable portion of a USB device that can source or sink data in a communications channel between the host and the device. The endpoint address is specified by the combination of the endpoint number and the endpoint direction.

The channel between the host and an endpoint at a specific device represents a data pipe. Endpoint 0 for a device is always a control type data channel used for device discovery and enumeration. Other types of endpoints supported by USB include bulk, interrupt, and isochronous. Each endpoint type has specific behavior related to packet response and error handling. More detail on endpoint operation can be found in the *USB 2.0 specification*.

The LPC18xx USB0 controller supports up to six endpoints.

Each endpoint direction is essentially independent and can be configured with differing behavior in each direction. For example, the DCD can configure endpoint 1-IN to be a bulk endpoint and endpoint 1-OUT to be an isochronous endpoint. This helps to conserve the total number of endpoints required for device operation. The only exception is that control endpoints must use both directions on a single endpoint number to function as a control endpoint. Endpoint 0, for example, is always a control endpoint and uses both directions.

Each endpoint direction requires a queue head allocated in memory. For is 6 endpoint numbers, one queue head for each endpoint direction is used by the device controller for a total of 12 queue heads. The operation of an endpoint and the use of queue heads are described later in this document.

23.10.5.1 Endpoint initialization

After hardware reset, all endpoints except endpoint zero are un-initialized and disabled. The DCD must configure and enable each endpoint by writing to the RXE or TXE bit in the ENDPTCTRLx register (see [Table 422](#)). Each 32-bit ENDPTCTRLx is split into an upper and lower half. The lower half of ENDPTCTRLx is used to configure the receive or OUT endpoint and the upper half is likewise used to configure the corresponding transmit or IN endpoint. Control endpoints must be configured the same in both the upper and lower half of the ENDPTCTRLx register otherwise the behavior is undefined. The following table shows how to construct a configuration word for endpoint initialization.

Table 431. Device controller endpoint initialization

Field	Value
Data Toggle Reset	1
Data Toggle Inhibit	0
Endpoint Type	00 - control
	01 - isochronous
	10 - bulk
	11 - interrupt
Endpoint Stall	0

23.10.5.2 Stalling

There are two occasions where the device controller may need to return to the host a STALL:

1. The first occasion is the **functional stall**, which is a condition set by the DCD as described in the *USB 2.0 device framework (chapter 9)*. A functional stall is only used on non-control endpoints and can be enabled in the device controller by setting the endpoint stall bit in the ENDPTCTRLx register associated with the given endpoint and the given direction. In a functional stall condition, the device controller will continue to return STALL responses to all transactions occurring on the respective endpoint and direction until the endpoint stall bit is cleared by the DCD.
2. A **protocol stall**, unlike a function stall, is only used on control endpoints and is automatically cleared by the device controller at the start of a new control transaction (setup phase). When enabling a protocol stall, the DCD should enable the stall bits (both directions) as a pair. A single write to the ENDPTCTRLx register can ensure that both stall bits are set at the same instant.

Remark: Any write to the ENDPTCTRLx register during operational mode must preserve the endpoint type field (i.e. perform a read-modify-write).

Table 432. Device controller stall response matrix

USB packet	Endpoint STALL bit	Effect on STALL bit	USB response
SETUP packet received by a non-control endpoint.	N/A	None	STALL
IN/OUT/PING packet received by a non-control endpoint.	1	None	STALL
IN/OUT/PING packet received by a non-control endpoint.	0	None	ACK/NAK/NYET
SETUP packet received by a control endpoint.	N/A	Cleared	ACK
IN/OUT/PING packet received by a control endpoint.	1	None	STALL
IN/OUT/PING packet received by a control endpoint.	0	None	ACK/NAK/NYET

23.10.5.3 Data toggle

Data toggle is a mechanism to maintain data coherency between host and device for any given data pipe. For more information on data toggle, refer to the *USB 2.0 specification*.

23.10.5.3.1 Data toggle reset

The DCD may reset the data toggle state bit and cause the data toggle sequence to reset in the device controller by writing a '1' to the data toggle reset bit in the ENDPTCTRLx register. This should only be necessary when configuring/initializing an endpoint or returning from a STALL condition.

23.10.5.3.2 Data toggle inhibit

Remark: This feature is for test purposes only and should never be used during normal device controller operation.

Setting the data toggle Inhibit bit active ('1') causes the device controller to ignore the data toggle pattern that is normally sent and accept all incoming data packets regardless of the data toggle state. In normal operation, the device controller checks the DATA0/DATA1 bit against the data toggle to determine if the packet is valid. If Data PID does not match the data toggle state bit maintained by the device controller for that endpoint, the data toggle is considered not valid. If the data toggle is not valid, the device controller assumes the packet was already received and discards the packet (not reporting it to the DCD). To prevent the host controller from re-sending the same packet, the device controller will respond to the error packet by acknowledging it with either an ACK or NYET response.

23.10.6 Operational model for packet transfers

All transactions on the USB bus are initiated by the host and in turn, the device must respond to any request from the host within the turnaround time stated in the USB 2.0 Specification. At USB 1.1 Full or Low Speed rates, this turnaround time was significant and the USB 1.1 device controllers were designed so that the device controller could access main memory or interrupt a host protocol processor in order to respond to the USB 1.1 transaction. The architecture of the USB 2.0 device controller is different because the same methods will not meet USB 2.0 High-speed turnaround time requirements by simply increasing the clock rate.

A USB host will send requests to the device controller in an order that can not be precisely predicted as a single pipeline, so it is not possible to prepare a single packet for the device controller to execute. However, the order of packet requests is predictable when the endpoint number and direction is considered. For example, if endpoint 3 (transmit direction) is configured as a bulk pipe, then we can expect the host will send IN requests to that endpoint. This device controller is designed in such a way that it can prepare packets for each endpoint/direction in anticipation of the host request. The process of preparing the device controller to send or receive data in response to host initiated transaction on the bus is referred to as "priming" the endpoint. This term will be used throughout the following documentation to describe the device controller operation so the DCD can be designed properly to use priming. Further, note that the term "flushing" is used to describe the action of clearing a packet that was queued for execution.

23.10.6.1 Priming transmit endpoints

Priming a transmit endpoint will cause the device controller to fetch the device transfer descriptor (dTd) for the transaction pointed to by the device queue head (dQH). After the dTd is fetched, it will be stored in the dQH until the device controller completes the transfer described by the dTd. Storing the dTd in the dQH allows the device controller to fetch the operating context needed to handle a request from the host without the need to follow the linked list, starting at the dQH when the host request is received. After the device has loaded the dTd, the leading data in the packet is stored in a FIFO in the device controller. This FIFO is split into virtual channels so that the leading data can be stored for any endpoint up to six endpoints for the LPC18xx USB0.

After a priming request is complete, an endpoint state of primed is indicated in the ENDPTSTATUS register. For a primed transmit endpoint, the device controller can respond to an IN request from the host and meet the stringent bus turnaround time of High Speed USB. Since only the leading data is stored in the device controller FIFO, it is necessary for the device controller to begin filling in behind leading data after the

transaction starts. The FIFO must be sized to account for the maximum latency that can be incurred by the system memory bus. On the LPC18xx, 128 x 36 bit dual port memory FIFOs are used for each IN endpoint.

23.10.6.2 Priming receive endpoints

Priming receive endpoints is identical to priming of transmit endpoints from the point of view of the DCD. At the device controller the major difference in the operational model is that there is no data movement of the leading packet data simply because the data is to be received from the host. Note as part of the architecture, the FIFO for the receive endpoints is not partitioned into multiple channels like the transmit FIFO. Thus, the size of the RX FIFO does not scale with the number of endpoints.

23.10.7 Interrupt/bulk endpoint operational model

The behaviors of the device controller for interrupt and bulk endpoints are identical. All valid IN and OUT transactions to bulk pipes will handshake with a NAK unless the endpoint had been primed. Once the endpoint has been primed, data delivery will commence.

A dTD will be retired by the device controller when the packets described in the transfer descriptor have been completed. Each dTD describes N packets to be transferred according to the USB Variable Length transfer protocol. The formula and table below describe how the device controller computes the number and length of the packets to be sent/received by the USB. The results vary according to the total number of bytes and maximum packet length (wMaxPacketSize).

With Zero Length Termination (ZLT) = 0

$$N = \text{INT}(\text{Number Of Bytes}/\text{wMaxPacketSize}) + 1$$

With Zero Length Termination (ZLT) = 1

$$N = \text{CEILING}(\text{Number Of Bytes}/\text{wMaxPacketSize})$$

Table 433. Variable length transfer protocol example (ZLT = 0)

Bytes (dTD)	Max Packet Length (dQH)	N	P1	P2	P3
511	256	2	256	255	-
512	256	3	256	256	0
512	512	2	512	0	-

Table 434. Variable length transfer protocol example (ZLT = 1)

Bytes (dTD)	Max Packet Length (dQH)	N	P1	P2	P3
511	256	2	256	255	-
512	256	2	256	256	-
512	512	1	512	-	-

Remark: The MULT field in the dQH must be set to “00” for bulk, interrupt, and control endpoints.

TX-dTD is complete when all packets described by the dTD were successfully transmitted. Total bytes in dTD will equal zero when this occurs.

RX-dTD is complete when:

- All packets described in the dTD were successfully received. The Total_bytes field in the dTD will equal zero when this occurs.
- A short packet (number of bytes < maximum packet length) was received. This is a successful transfer completion; DCD must check the Total_bytes field in the dTD to determine the number of bytes that are remaining. From the total bytes remaining in the dTD, the DCD can compute the actual bytes received.
- A long packet was received (number of bytes > maximum packet size) OR (total bytes received > total bytes specified). This is an error condition. The device controller will discard the remaining packet, and set the Buffer Error bit in the dTD. In addition, the endpoint will be flushed and the USBERR interrupt will become active.

On the successful completion of the packet(s) described by the dTD, the active bit in the dTD will be cleared and the next pointer will be followed when the Terminate bit is clear. When the Terminate bit is set, the device controller will flush the endpoint/direction and cease operations for that endpoint/direction. On the unsuccessful completion of a packet (see long packet above), the dQH will be left pointing to the dTD that was in error. In order to recover from this error condition, the DCD must properly reinitialize the dQH by clearing the active bit and update the nextTD pointer before attempting to re-prime the endpoint.

Remark: All packet level errors such as a missing handshake or CRC error will be retried automatically by the device controller.

There is no required interaction with the DCD for handling such errors.

23.10.7.1 Interrupt/bulk endpoint bus response matrix

Table 435. Interrupt/bulk endpoint bus response matrix

Token type	STALL	Not primed	Primed	Underflow	Overflow
Setup	Ignore	Ignore	Ignore	n/a	n/a
In	STALL	NAK	Transmit	BS error	n/a
Out	STALL	NAK	Receive and NYET/ACK	n/a	NAK
Ping	STALL	NAK	ACK	n/a	n/a
Invalid	Ignore	Ignore	Ignore	Ignore	Ignore

[1] BS error = Force Bit Stuff Error

[2] NYET/ACK – NYET unless the Transfer Descriptor has packets remaining according to the USB variable length protocol then ACK.

[3] SYSERR – System error should never occur when the latency FIFOs are correctly sized and the DCD is responsive.

23.10.8 Control endpoint operational model

23.10.8.1 Setup phase

All requests to a control endpoint begin with a setup phase followed by an optional data phase and a required status phase. The device controller will always accept the setup phase unless the setup lockout is engaged.

The setup lockout will engage so that future setup packets are ignored. Lockout of setup packets ensures that while software is reading the setup packet stored in the queue head, that data is not written as it is being read potentially causing an invalid setup packet.

In hardware the setup lockout mechanism can be disabled and a new tripwire type semaphore will ensure that the setup packet payload is extracted from the queue head without being corrupted by an incoming setup packet. This is the preferred behavior because ignoring repeated setup packets due to long software interrupt latency would be a compliance issue.

23.10.8.1.1 Setup packet handling using setup lockout mechanism

After receiving an interrupt and inspecting USBMODE to determine that a setup packet was received on a particular pipe:

1. Duplicate contents of dQH.SetupBuffer into local software byte array.
2. Write '1' to clear corresponding ENDPTSETUPSTAT bit and thereby disabling Setup Lockout (i.e. the Setup Lockout activates as soon as a setup packet arrives. By writing to the ENDPTSETUPSTAT, the device controller will accept new setup packets.).
3. Process setup packet using local software byte array copy and execute status/handshake phases.

Remark: After receiving a new setup packet the status and/or handshake phases may still be pending from a previous control sequence. These should be flushed & deallocated before linking a new status and/or handshake dTD for the most recent setup packet.

4. Before priming for status/handshake phases ensure that ENDPTSETUPSTAT is '0'. The time from writing a '1' to ENDPTSETUPSTAT and reading back a '0' may vary according to the type of traffic on the bus up to nearly a 1 ms. However, it is absolutely necessary to ensure ENDPTSETUPSTAT has transitioned to '0' after step 1 and before priming for the status/handshake phases.

Remark: To limit the exposure of setup packets to the setup lockout mechanism (if used), the DCD should designate the priority of responding to setup packets above responding to other packet completions.

23.10.8.1.2 Setup packet handling using the trip wire mechanism

- Disable Setup Lockout by writing '1' to Setup Lockout Mode (SLOM) in the USBMODE register (once at initialization). Setup lockout is not necessary when using the tripwire as described below.

Remark: Leaving the Setup Lockout Mode As '0' will result in pre-2.3 hardware behavior.

- After receiving an interrupt and inspecting ENDPTSETUPSTAT to determine that a setup packet was received on a particular pipe:
 - a. Write '1' to clear corresponding bit ENDPTSETUPSTAT.
 - b. Write '1' to Setup Tripwire (SUTW) in USBCMD register.
 - c. Duplicate contents of dQH.SetupBuffer into local software byte array.
 - d. Read Setup TripWire (SUTW) in USBCMD register. (if set - continue; if cleared - go to b).
 - e. Write '0' to clear Setup Tripwire (SUTW) in USBCMD register.

- f. Process setup packet using local software byte array copy and execute status/handshake phases.
- g. Before priming for status/handshake phases ensure that ENDPTSETUPSTAT is '0'.
 - A poll loop should be used to wait until ENDPTSETUPSTAT transitions to '0' after step a) above and before priming for the status/handshake phases.
 - The time from writing a '1' to ENDPTSETUPSTAT and reading back a '0' is very short (~1-2 us) so a poll loop in the DCD will not be harmful.

Remark: After receiving a new setup packet the status and/or handshake phases may still be pending from a previous control sequence. These should be flushed & deallocated before linking a new status and/or handshake dTD for the most recent setup packet.

23.10.8.2 Data phase

Following the setup phase, the DCD must create a device transfer descriptor for the data phase (if present) and prime the transfer.

After priming the packet, the DCD must verify that a new setup packet has not been received by reading the ENDPTSETUPSTAT register immediately. This step verifies that the prime has completed. A prime completes when the associated bit in the ENDPTPRIME register is zero and the associated bit in the ENDPTSTATUS register is one. If a prime fails, i.e. the ENDPTPRIME bit goes to zero and the ENDPTSTATUS bit is not set, then the prime has failed. This can only be due to improper setup of the dQH, dTD or a setup arriving during the prime operation. If a new setup packet is indicated after the ENDPTPRIME bit is cleared, then the transfer descriptor can be freed and the DCD must reinterpret the setup packet.

Should a setup arrive after the data stage is primed, the device controller will automatically clear the prime status (ENDPTSTATUS) to enforce data coherency with the setup packet.

Remark: The MULT field in the dQH must be set to "00" for bulk, interrupt, and control endpoints.

Remark: Error handling of data phase packets is the same as bulk packets described previously.

23.10.8.3 Status phase

Similar to the data phase, the DCD must create a transfer descriptor (with byte length equal zero) and prime the endpoint for the status phase. The DCD must also perform the same checks of the ENDPTSETUPSTAT as described above in the data phase.

Remark: The MULT field in the dQH must be set to "00" for bulk, interrupt, and control endpoints.

Remark: Error handling of status phase packets is the same as bulk packets described previously.

23.10.8.4 Control endpoint bus response matrix

Shown in the following table is the device controller response to packets on a control endpoint according to the device controller state.

Table 436. Control endpoint bus response matrix

Token type	Endpoint state					Setup lockout
	STALL	Not primed	Primed	Underflow	Overflow	
Setup	ACK	ACK	ACK	n/a	SYSERR	-
In	STALL	NAK	Transmit	BS error	n/a	n/a
Out	STALL	NAK	Receive and NYET/ACK	n/a	NAK	n/a
Ping	STALL	NAK	ACK	n/a	n/a	n/a
Invalid	Ignore	Ignore	Ignore	Ignore	Ignore	ignore

[1] BS error = Force Bit Stuff Error

[2] NYET/ACK – NYET unless the Transfer Descriptor has packets remaining according to the USB variable length protocol then ACK.

[3] SYSERR – System error should never occur when the latency FIFOs are correctly sized and the DCD is responsive.

23.10.9 Isochronous endpoint operational model

Isochronous endpoints are used for real-time scheduled delivery of data, and their operational model is significantly different from the host throttled Bulk, Interrupt, and Control data pipes. Real time delivery by the device controller is accomplished by the following:

- Exactly MULT Packets per (micro) Frame are transmitted/received. Note: MULT is a two-bit field in the device Queue Head. The variable length packet protocol is not used on isochronous endpoints.
- NAK responses are not used. Instead, zero length packets are sent in response to an IN request to an unprimed endpoint. For unprimed RX endpoints, the response to an OUT transaction is to ignore the packet within the device controller.
- Prime requests always schedule the transfer described in the dTD for the next (micro) frame. If the ISO-dTD is still active after that frame, then the ISO-dTD will be held ready until executed or canceled by the DCD.

An EHCI compatible host controller uses the periodic frame list to schedule data exchanges to Isochronous endpoints. The operational model for device mode does not use such a data structure. Instead, the same dTD used for Control/Bulk/Interrupt endpoints is also used for isochronous endpoints. The difference is in the handling of the dTD.

The first difference between bulk and ISO-endpoints is that priming an ISO-endpoint is a delayed operation such that an endpoint will become primed only after a SOF is received. After the DCD writes the prime bit, the prime bit will be cleared as usual to indicate to software that the device controller completed priming the dTD for transfer. Internal to the design, the device controller hardware masks that prime start until the next frame boundary. This behavior is hidden from the DCD but occurs so that the device controller can match the dTD to a specific (micro) frame.

Another difference with isochronous endpoints is that the transaction must wholly complete in a (micro) frame. Once an ISO transaction is started in a (micro) frame it will retire the corresponding dTD when MULT transactions occur or the device controller finds

a fulfillment condition. The transaction error bit set in the status field indicates a fulfillment error condition. When a fulfillment error occurs the device controller will force- retire the ISO-dTD and move to the next ISO-dTD.

It is important to note that fulfillment errors are only caused due to partially completed packets. If no activity occurs to a primed ISO-dTD, the transaction will stay primed indefinitely. This means it is up to software discard transmit ISO-dTDs that pile up from a failure of the host to move the data. Finally, the last difference with ISO packets is in the data level error handling. When a CRC error occurs on a received packet, the packet is not retried similar to bulk and control endpoints. Instead, the CRC is noted by setting the Transaction Error bit and the data is stored as usual for the application software to sort out.

TX packet retired

- MULT counter reaches zero.
- Fulfillment Error [Transaction Error bit is set].
- # Packets Occurred > 0 AND # Packets Occurred < MULT.

Remark: For TX-ISO, MULT Counter can be loaded with a lesser value in the dTD Multiplier Override field. If the Multiplier Override is zero, the MULT Counter is initialized to the Multiplier in the QH.

RX packet retired

- MULT counter reaches zero.
- Non-MDATA Data PID is received.
Remark: Exit criteria only valid in hardware version 2.3 or later. Previous to hardware version 2.3, any PID sequence that did not match the MULT field exactly would be flagged as a transaction error due to PID mismatch or fulfillment error.
- Overflow Error:
 - Packet received is > maximum packet length. [Buffer Error bit is set].
 - Packet received exceeds total bytes allocated in dTD. [Buffer Error bit is set].
- Fulfillment error [Transaction Error bit is set]:
Packets Occurred > 0 AND # Packets Occurred < MULT.
- CRC Error [Transaction Error bit is set]

Remark: For ISO, when a dTD is retired, the next dTD is primed for the next frame. For continuous (micro) frame to (micro) frame operation the DCD should ensure that the dTD linked-list is out ahead of the device controller by at least two (micro) frames.

23.10.9.1 Isochronous pipe synchronization

When it is necessary to synchronize an isochronous data pipe to the host, the (micro) frame number (FRINDEX register) can be used as a marker. To cause a packet transfer to occur at a specific (micro) frame number [N], the DCD should interrupt on SOF during frame N-1. When the FRINDEX = N - 1, the DCD must write the prime bit. The device controller will prime the isochronous endpoint in (micro) frame N-1 so that the device controller will execute delivery during (micro) frame N.

Remark: Priming an endpoint towards the end of (micro) frame N-1 will not guarantee delivery in (micro) frame N. The delivery may actually occur in (micro) frame N+1 if the device controller does not have enough time to complete the prime before the SOF for packet N is received.

23.10.9.2 Isochronous endpoint bus response matrix

Table 437. Isochronous endpoint bus response matrix

Token type	STALL	Not primed	Primed	Underflow	Overflow
Setup	STALL	STALL	STALL	n/a	n/a
In	NULL packet	NULL packet	Transmit	BS error	n/a
Out	Ignore	Ignore	Receive	n/a	Drop packet
Ping	Ignore	Ignore	Ignore	Ignore	Ignore
Invalid	Ignore	Ignore	Ignore	Ignore	Ignore

[1] BS error = Force Bit Stuff Error

[2] NULL packet = Zero length packet.

23.10.10 Managing queue heads

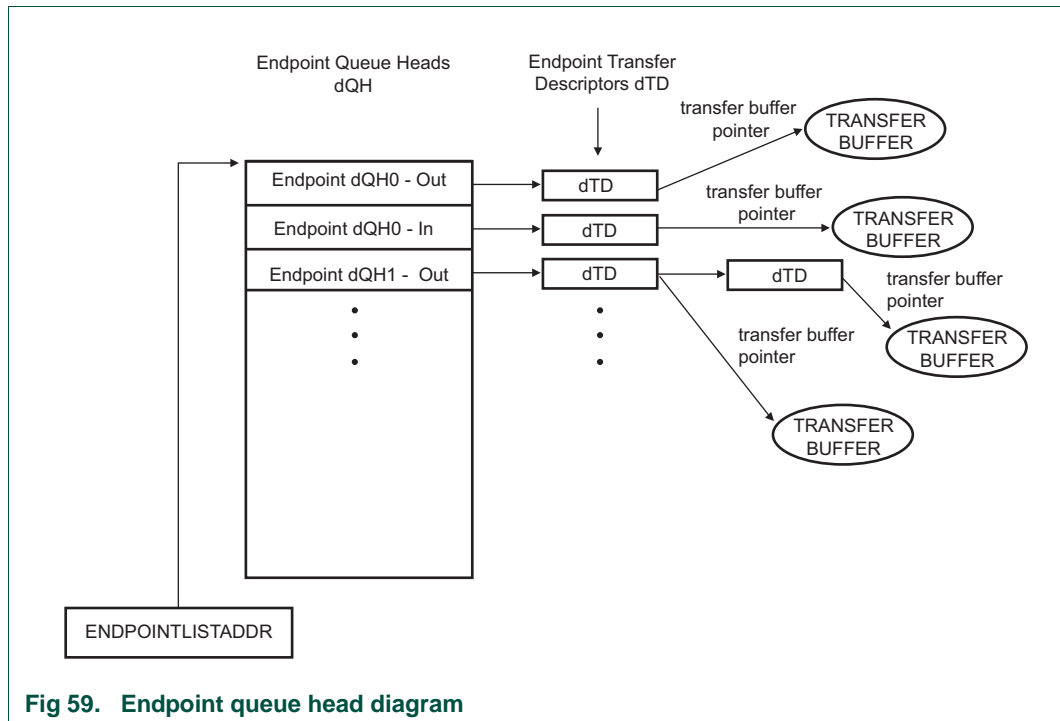

Fig 59. Endpoint queue head diagram

The device queue head (dQH) points to the linked list of transfer tasks, each depicted by the device Transfer Descriptor (dTD). An area of memory pointed to by ENDPOINTLISTADDR contains a group of all dQH's in a sequential list as shown in Figure 59. The even elements in the list of dQH's are used for receive endpoints (OUT) and the odd elements are used for transmit endpoints (IN). Device transfer descriptors are linked head to tail starting at the queue head and ending at a terminate bit. Once the dTD has been retired, it will no longer be part of the linked list from the queue head. Therefore,

software is required to track all transfer descriptors since pointers will no longer exist within the queue head once the dTD is retired (see [Section 23.10.11.1](#)).

In addition to the current and next pointers and the dTD overlay examined in section [Section 23.10.6](#), the dQH also contains the following parameters for the associated endpoint: Multiplier, Maximum Packet Length, Interrupt On Setup. The complete initialization of the dQH including these fields is demonstrated in the next section.

23.10.10.1 Queue head initialization

Initialize one pair of device queue heads for the control endpoint. For each non-control endpoint direction used, initialize one queue head. To initialize a device queue head, follow these steps:

- Write the `wMaxPacketSize` field as required by the *USB Chapter 9* or application specific protocol.
- Write the multiplier field to 0 for control, bulk, and interrupt endpoints. For ISO endpoints, set the multiplier to 1, 2, or 3 as required by the bandwidth and in accordance with the *USB Chapter 9 protocol*. Note: In FS mode, the multiplier field can only be 1 for ISO endpoints.
- Write the next dTD Terminate bit field to “1”.
- Write the Active bit in the status field to “0”.
- Write the Halt bit in the status field to “0”.

Remark: The DCD must only modify dQH if the associated endpoint is not primed and there are no outstanding dTD's.

23.10.10.2 Operational model for setup transfers

As discussed in section Control Endpoint Operational Model ([Section 23.10.8](#)), a setup transfer requires special treatment by the DCD. A setup transfer does not use a dTD but instead stores the incoming data from a setup packet in an 8-byte buffer within the dQH.

Upon receiving notification of the setup packet, the DCD should handle the setup transfer as demonstrated here:

1. Copy the setup buffer contents from dQH - RX to software buffer.
2. Acknowledge setup backup by writing a “1” to the corresponding bit in `ENDPTSETUPSTAT`.

Remark: The acknowledge must occur before continuing to process the setup packet.

Remark: After the acknowledge has occurred, the DCD must not attempt to access the setup buffer in the dQH – RX. Only the local software copy should be examined.

3. Check for pending data or status dTD's from previous control transfers and flush if any exist as discussed in section Flushing/De-priming an Endpoint.

Remark: It is possible for the device controller to receive setup packets before previous control transfers complete. Existing control packets in progress must be flushed and the new control packet completed.

4. Decode setup packet and prepare data phase [optional] and status phase transfer as require by the *USB Specification Chapter 9* or application specific protocol.

23.10.11 Managing transfers with transfer descriptors

23.10.11.1 Software link pointers

It is necessary for the DCD software to maintain head and tail pointers to the linked list of dTDs for each respective queue head. This is necessary because the dQH only maintains pointers to the current working dTD and the next dTD to be executed. The operations described in following sections for managing dTD will assume the DCD can reference the head and tail of the dTD linked list.

Remark: To conserve memory, the reserved fields at the end of the dQH can be used to store the Head & Tail pointers but it still remains the responsibility of the DCD to maintain the pointers.

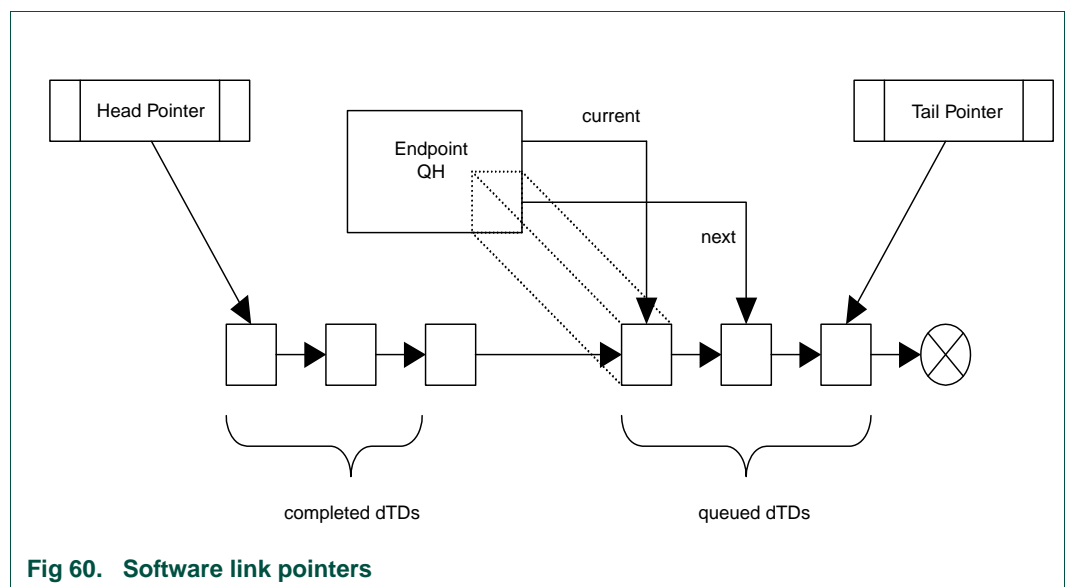

23.10.11.2 Building a transfer descriptor

Before a transfer can be executed from the linked list, a dTD must be built to describe the transfer. Use the following procedure for building dTDs:

Allocate 8-DWord dTD block of memory aligned to 8-DWord boundaries. Example: bit address 4:0 would be equal to “00000”.

Write the following fields:

1. Initialize first 7 DWords to 0.
2. Set the terminate bit to “1”.
3. Fill in total bytes with transfer size.
4. Set the interrupt on complete if desired.
5. Initialize the status field with the active bit set to “1” and all remaining status bits set to “0”.
6. Fill in buffer pointer page 0 and the current offset to point to the start of the data buffer.
7. Initialize buffer pointer page 1 through page 4 to be one greater than each of the previous buffer pointers.

23.10.11.3 Executing a transfer descriptor

To safely add a dTD, the DCD must follow this procedure which will handle the event where the device controller reaches the end of the dTD list at the same time a new dTD is being added to the end of the list.

Determine whether the linked list is empty: Check DCD driver to see if pipe is empty (internal representation of linked list should indicate if any packets are outstanding).

Linked list is empty

1. Write dQH next pointer AND dQH terminate bit to 0 as a single DWord operation.
2. Clear active and halt bits in dQH (in case set from a previous error).
3. Prime endpoint by writing '1' to correct bit position in ENDPTPRIME.

Linked list is not empty

1. Add dTD to end of the linked list.
2. Read correct prime bit in ENDPTPRIME – if '1' DONE.
3. Set ATDTW bit in USBCMD register to '1'.
4. Read correct status bit in ENDPTSTAT. (Store in temp variable for later).
5. Read ATDTW bit in USBCMD register.
 - If '0' go to step 3.
 - If '1' continue to step 6.
6. Write ATDTW bit in USBCMD register to '0'.
7. If status bit read in step 4 (ENDPSTAT reg) indicates endpoint priming is DONE (corresponding ERBRx or ETBRx is one): DONE.
8. If status bit read in step 4 is 0 then go to Linked list is empty: Step 1.

23.10.11.4 Transfer completion

After a dTD has been initialized and the associated endpoint primed the device controller will execute the transfer upon the host-initiated request. The DCD will be notified with a USB interrupt if the Interrupt On Complete bit was set or alternately, the DCD can poll the endpoint complete register to find when the dTD had been executed. After a dTD has been executed, DCD can check the status bits to determine success or failure.

Remark: Multiple dTD can be completed in a single endpoint complete notification. After clearing the notification, DCD must search the dTD linked list and retire all dTDs that have finished (Active bit cleared).

By reading the status fields of the completed dTDs, the DCD can determine if the transfers completed successfully. Success is determined with the following combination of status bits:

Active = 0
 Halted = 0
 Transaction Error = 0
 Data Buffer Error = 0

Should any combination other than the one shown above exist, the DCD must take proper action. Transfer failure mechanisms are indicated in the Device Error Matrix (see [Table 438](#)).

In addition to checking the status bit, the DCD must read the Total_bytes field to determine the actual bytes transferred. When a transfer is complete, the Total_bytes field is decremented by the actual bytes transferred. For Transmit packets, a packet is only complete after the Total_bytes field reaches zero, but for receive packets, the host may send fewer bytes in the transfer according to the USB variable length packet protocol.

23.10.11.5 Flushing an endpoint

It is necessary for the DCD to flush one or more endpoints on a USB device reset or during a broken control transfer. There may also be application specific requirements to stop transfers in progress. The following procedure can be used by the DCD to stop a transfer in progress:

1. Write a '1' to the corresponding bit(s) in ENDPTFLUSH.
2. Wait until all bits in ENDPTFLUSH are '0'.

Remark: Software note: This operation may take a large amount of time depending on the USB bus activity. It is not desirable to have this wait loop within an interrupt service routine.

3. Read the ENDPTSTAT register to ensure that for all endpoints commanded to be flushed the corresponding bits are now '0'. If the corresponding bits are '1' after step #2 has finished, then the flush failed as described in the following:

In very rare cases, a packet is in progress to the particular endpoint when commanded flush using ENDPTFLUSH. A safeguard is in place to refuse the flush to ensure that the packet in progress completes successfully. The DCD may need to repeatedly flush any endpoints that fail to flush by repeating steps 1-3 until each endpoint is successfully flushed.

23.10.11.6 Device error matrix

[Table 438](#) summarizes packet errors that are not automatically handled by the device controller.

The following errors can occur:

Overflow: Number of bytes received exceeded max. packet size or total buffer length. This error will also set the Halt bit in the dQH, and if there are dTDs remaining in the linked list for the endpoint, then those will not be executed.

ISO packet error: CRC Error on received ISO packet. Contents not guaranteed to be correct.

ISO fulfillment error: Host failed to complete the number of packets defined in the dQH MULT field within the given (micro) frame. For scheduled data delivery the DCD may need to readjust the data queue because a fulfillment error will cause the device controller to cease data transfers on the pipe for one (micro) frame. During the "dead" (micro) frame, the device controller reports error on the pipe and primes for the following (micro) frame

Table 438. Device error matrix

Error	Direction	Packet type	Data buffer error bit	Transaction error bit
Overflow	Rx	Any	1	0
ISO packet error	Rx	ISO	0	1
ISO fulfillment error	Both	ISO	0	1

23.10.12 Servicing interrupts

The interrupt service routine must consider different types of interrupts for high-frequency and low-frequency, and error operations and specify the priorities accordingly.

23.10.12.1 High-frequency interrupts

High frequency interrupts in particular should be handled in the order below. The most important of these is listed first because the DCD must acknowledge a setup buffer in the timeliest manner possible.

Table 439. High-frequency interrupt events

Execution order	Interrupt	Action
1a	USB interrupt: ENDPTSETUPSTATUS [1]	Copy contents of setup buffer and acknowledge setup packet (as indicated in Section 23.10.10). Process setup packet according to <i>USB 2.0 Chapter 9</i> or application specific protocol.
1b	USB interrupt: ENDPTCOMPLETE [1]	Handle completion of dTD as indicated in Section 23.10.10 .
2	SOF interrupt	Action as deemed necessary by application. This interrupt may not have a use in all applications.

[1] It is likely that multiple interrupts stack up on any call to the Interrupt Service Routine AND during the Interrupt Service Routine.

23.10.12.2 Low-frequency interrupts

The low frequency events include the following interrupts. These interrupt can be handled in any order since they don't occur often in comparison to the high-frequency interrupts.

Table 440. Low-frequency interrupt events

Interrupt	Action
Port change	Change software state information.
Sleep enable (Suspend)	Change software state information. Low power handling as necessary.
Reset Received	Change software state information. Abort pending transfers.

23.10.12.3 Error interrupts

Error interrupts will be least frequent and should be placed last in the interrupt service routine.

Table 441. Error interrupt events

Interrupt	Action
USB error interrupt	This error is redundant because it combines USB Interrupt and an error status in the dTD. The DCD will more aptly handle packet-level errors by checking dTD status field upon receipt of USB Interrupt (w/ ENDPTCOMPLETE).
System error	Unrecoverable error. Immediate Reset of core; free transfers buffers in progress and restart the DCD.

23.11 System error

The USB controller is an AHB bus master and any interaction between the USB controller and the system may experience errors. The type of error may be catastrophic to the USB controller (such as a Master Abort), making it impossible for the USB controller to continue in a coherent manner. In the presence of non-catastrophic errors, such as parity errors, the USB controller could potentially continue operation. The recommended behavior for these types of errors is to escalate it to a catastrophic error and halt the USB controller. A system error will result in the following actions:

- The Run/Stop bit in the USBCMD register is set to zero.
- The following bits in the USBSTS register are set:
 - System Error bit is set to a one.
 - HChalted bit is set to a one.
- If the System Error Enable bit in the USBINTR register is a one, then the USB controller will issue a hard interrupt.

Remark: After a system error, the software must reset the USB controller via HCReset in the UBCMD register before re-initializing and re-starting the USB controller.

The most likely cause of system error in device mode is that the pointer fields (next dTD pointer, buffer pointer) in endpoint transfer descriptors or in endpoint queue head got corrupted (pointing to inaccessible memory location). The DCD should always provide pointers to the USB controller accessible memory area. See [Figure 7](#). To avoid corruption of endpoint transfer descriptors due to race conditions between the DCD and the USB controller, the DCD must follow the safety procedure described in [Section 23.10.11.3 “Executing a transfer descriptor”](#) to add new dTD to the queue. When creating new queue heads, the DCD must ensure that the EP is disabled or the queue is empty. If the queue is not empty, the DCD should flush the endpoint first before altering the queue head structure.

23.12 USB power optimization

The USB-HS core is a fully synchronous static design. Applications that transfer more data or use a greater number of packets to be sent will consume a greater amount of power.

The USB power consumption can be controlled by disabling the USB clocks and disabling the High-speed PHY (see [Section 23.1](#)).

A device may go into the Suspended state either autonomously by disconnecting from the USB, or in response to USB suspend signaling.

23.12.1 USB power states

The USB provides a mechanism to place segments of the USB or the entire USB into a low-power Suspended state. USB devices are required to respond to a 3ms lack of activity on the USB bus by going into a Suspended state. In the USB-HS core software is notified of the suspend condition via the transition of the SUSP bit in the PORTSC1 register. Optionally an interrupt can be generated which is controlled by the port change Detect Enable bit in the USBINTR control register. Software then has 7 ms to transition a bus powered device into the Suspended state. In the Suspended state, a USB device has a maximum USB bus power budget of 2.5 mA. In general, to achieve that level of power conservation, most of the device circuits will need to be switched off, or clock at an extremely low frequency. This can be accomplished by suspending the clock.

The implementation of low power states in the USB-HS core is dependent on the use of the device role (host or peripheral), whether the device is bus powered, and the selected clock architecture of the core.

Bus powered peripheral devices are required by the USB specification to support a low power Suspended state. Self powered peripheral devices and hosts set their own power management strategies based on their system level requirements.

Before the system clock is suspended or set to a frequency that is below the operational frequency of the USB-HS core, the core must be moved from the operational state to a low power state.

23.12.2 Device power states

A bus powered peripheral device must move through the power states as directed by the host. Optionally autonomously directed low power states may be implemented.

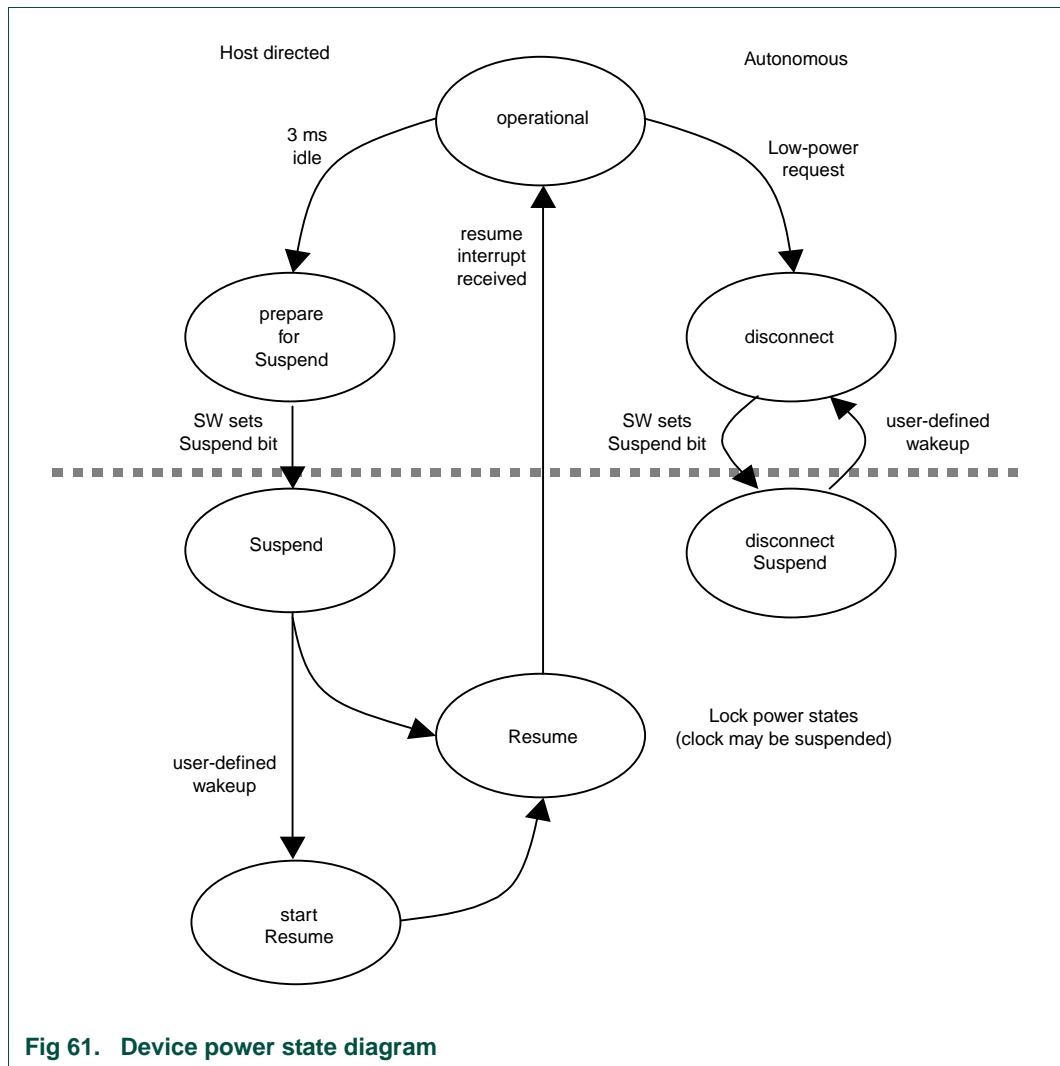

Fig 61. Device power state diagram

In the operational state both the transceiver clock and system clocks are running. Software can initiate a low power mode autonomously by disconnecting from the host to go into the disconnect state. Once in this state, the software can set the Suspend bit to turn off the transceiver clock putting the system into the disconnect-Suspended state. Since software cannot depend on the presence of a clock to clear the Suspend bit, a wake-up event must be defined which would clear the suspend bit and allow the transceiver clock to resume.

The device can also go into suspend mode as a result of a suspend command from the host. Suspend is signaled on the bus by 3 ms of idle time on the bus. This will generate a suspend interrupt to the software at which point the software must prepare to go into suspend then set the suspend bit. Once the Suspend bit is set, the transceiver clock may turn off and the device will be in the suspended state. The device has two ways of getting out of suspend.

1. If remote wake-up is enabled, a wake-up event could be defined which would clear the Suspend bit. The software would then initiate the resume by setting the Resume bit in the port controller then waiting for a port change interrupt indicating that the port is in an operational state.

- If the host puts resume signaling on the bus, it will clear the Suspend bit and generate a port change interrupt when the resume is finished.

Remark: The Suspend interrupt is generated by the USB block whenever it detects that the bus is idle for more than 3 ms. However, during the enumeration process some hosts wait longer than 3 ms after issuing reset and before transmitting any tokens on bus. Hence software should implement a debounce logic for suspend interrupt handling to detect a true suspend command issued by host.

23.12.3 Host power states

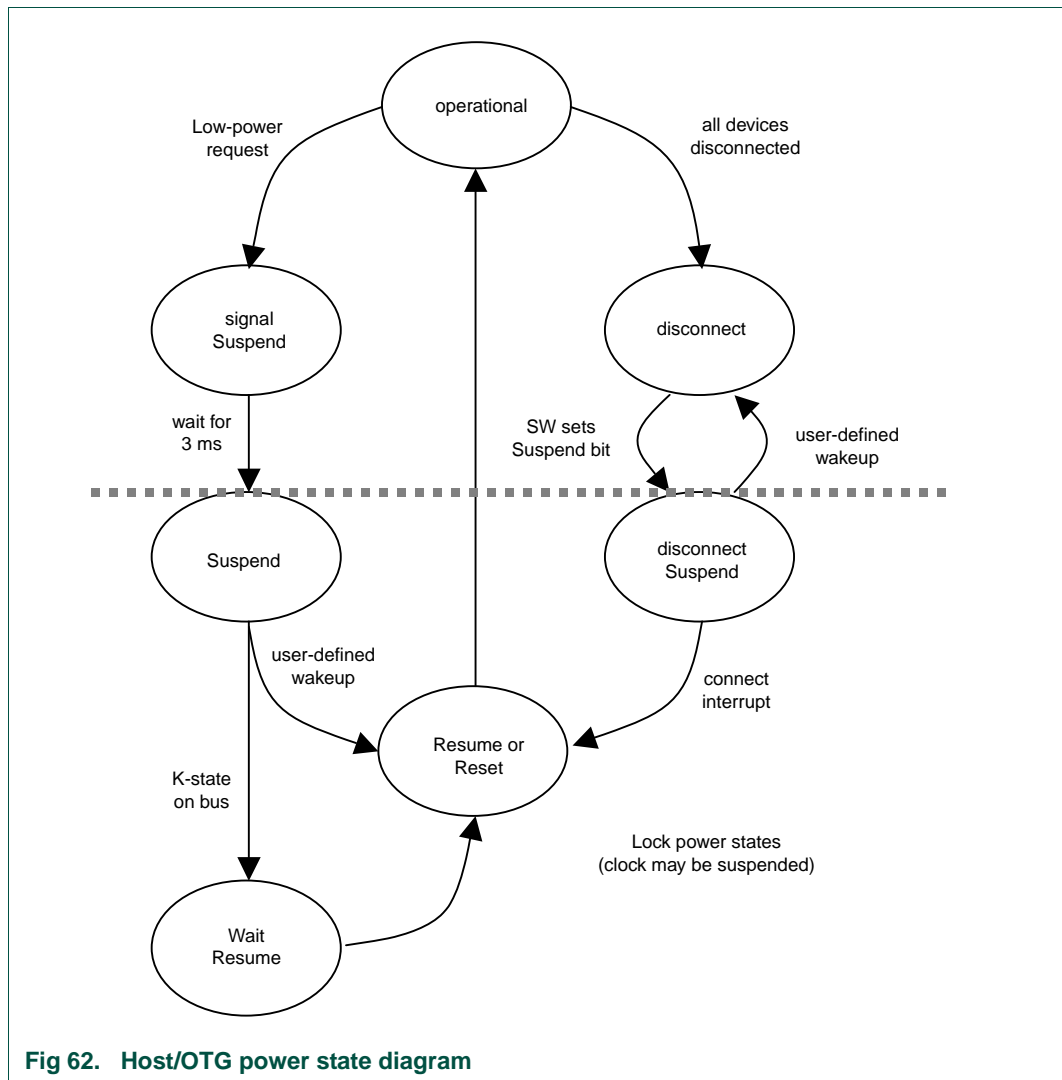

Fig 62. Host/OTG power state diagram

From an operational state when a host gets a low power request, it must set the suspend bit in the port controller. This will put an idle on the bus, block all traffic through the port, and turn off the transceiver clock. There are two ways for a host controller to get out of the Suspended state. If it has enabled remote wake-up, a K-state on the bus will turn on the transceiver clock and generate an interrupt. The software will then have to wait 20 ms for the resume to complete and the port to go back to an active state. Alternatively an

external event could clear the suspend bit and start the transceiver clock running again. The software can then initiate a resume by setting the resume bit in the port controller, or force a reconnect by setting the reset bit in the port controller.

If all devices have disconnected from the host, the host can go into a low power mode by the software setting the suspend bit. From the disconnect-Suspended state a connect event can start the transceiver clock and interrupt the software. The software then needs to set the reset bit to start the connect process.

23.12.4 Susp_CTRL module for USB0

The SUSP_CTRL module implements the power management logic of the USB block. It controls the suspend input of the transceiver. Asserting this suspend signal (PORTSC1.PHCD bit) will put the transceiver in suspend mode and the 480 MHz clock or the 60 MHz clock will be switched off.

In suspend mode, the transceiver will raise an output signal indicating that the PLL generating the 480 MHz clock can be switched off.

For USB0 this signal is connected to event #9 (USB0_L) in the event router (see [Table 74](#)). Software should check for this signal to be HIGH before stopping the USB PLL and putting the chip in low power mode. Note that the event router block doesn't support a raw pin status register hence HIGH level detection should be configured for this pin to detect when to turn the PLL off. Similarly, to detect resume signaling to leave the low power state, software should configure this pin to detect a LOW-level in the event router.

The SUSP_CTRL module also generates an output signal indicating whether the AHB clock is needed or not. If not the AHB clock is allowed to be switched off or reduced in frequency in order to save power. For USB0, this signal is used to turn off the AHB clock to USB block.

The core will enter the low power state if:

- software sets the PORTSC1.PHCD bit.

When operating in host mode, the core will leave the low power state on one of the following conditions:

- software clears the PORTSC1.PHCD bit
- a device is connected and the PORTSC1.WKCN bit is set
- a device is disconnected and the PORTSC1.WKDC bit is set
- an over-current condition occurs and the PORTSC1.WKOC bit is set
- a remote wake-up from the attached device occurs (when USB bus was in suspend)
- a change on vbusvalid occurs (= VBUS threshold at 4.4 V is crossed)
- a change on bvalid occurs (=VBUS threshold at 4.0 V is crossed).

When operating in device mode, the core will leave the low power state on one of the following conditions:

- software clears the PORTSC1.PHCD bit.
- a change on the USB data lines (dp/dm) occurs.
- a change on vbusvalid occurs (= VBUS threshold at 4.4 V is crossed).

- a change on bvalid occurs (= VBUS threshold at 4.0 V is crossed).

The vbusvalid and bvalid signals coming from the transceiver are not filtered in the SUSP_CTRL module. Any change on those signals will cause a wake-up event. Hence for USB0, it is recommended that the OTG_DISCHARGE resistor be enabled, by setting OTGSC.VD bit, before entering low power mode.

24.1 How to read this chapter

The USB1 Host/Device controller is available on parts LPC185x and LPC183x.

USB frame length adjustment is available for parts with on-chip flash only.

24.2 Basic configuration

The USB1 controller is configured as follows:

- See [Table 442](#) for clocking and power control.
- The USB1 is reset by a USB1_RST (reset # 18).
- The USB1 interrupt is connected to interrupt slot # 9 in the NVIC. The USB AHB_NEED_CLK signal is connected to slot # 10 in the event router (see also [Section 24.7.1](#)).
- In the SFSUSB register, the USB_ESEA bit must be set to 1 for the USB1 to operate (see [Table 177](#)).
- The registers for frame length adjustment in USB host mode are located in the CREG block (see [Table 99](#); parts with on-chip flash only).

Table 442. USB1 clocking and power control

	Base clock	Branch clock	Operating frequency	Notes
USB1 clock	BASE_USB1_CLK	CLK_USB1	60 MHz	Uses PLL1. CLK_USB1 must be 60 MHz when the USB1 is operating in low-speed and full-speed modes. In high-speed mode, the clock is provided by the ULPI PHY.
USB1 register interface clock	BASE_M3_CLK	CLK_M3_USB1	up to 180 MHz	

24.2.1 Full-speed mode without external PHY

In Full-speed mode, use CLK_USB1 to generate a clock for the USB1 interface.

24.2.2 High-speed mode with ULPI interface

In High-speed mode, the external PHY generates the clock for the USB1 interface, and the USB1_ULPI_CLK must be enabled on pins PC_0 or P8_8 through their respective pin configuration registers in the system configuration block. The USB1 branch clock CLK_USB1 must be disabled.

24.3 Features

- Supports all high-speed USB-compliant peripherals if connected to external ULPI PHY.

- Supports all full-speed USB-compliant peripherals.
- Complies with *Universal Serial Bus specification 2.0*.
- Complies with *Enhanced Host Controller Interface Specification*.
- Supports auto USB 2.0 mode discovery.
- Supports three logical endpoints plus one control endpoint for a total of 8 physical endpoints.
- This module has its own, integrated DMA engine.
- Support for frame length adjustment to correlate the SOF signal with an external clock (see [Section 23.7.7.1](#)).

24.4 General description

The USB1 controller provides plug-and-play connection of peripheral devices to a host with three different data speeds: High-Speed with a data rate of 480 Mbps (with external PHY only), Full-Speed with a data rate of 12 Mbps, Low-Speed with a data rate of 1.5 Mbps. Many portable devices can benefit from the ability to communicate to each other over the USB interface without intervention of a host PC.

Support of the High-Speed data rate requires an external USB HS OTG PHY that connects to the USB controller via the ULPI interface. Full-Speed or Low-Speed is supported through the on-chip Full-speed PHY.

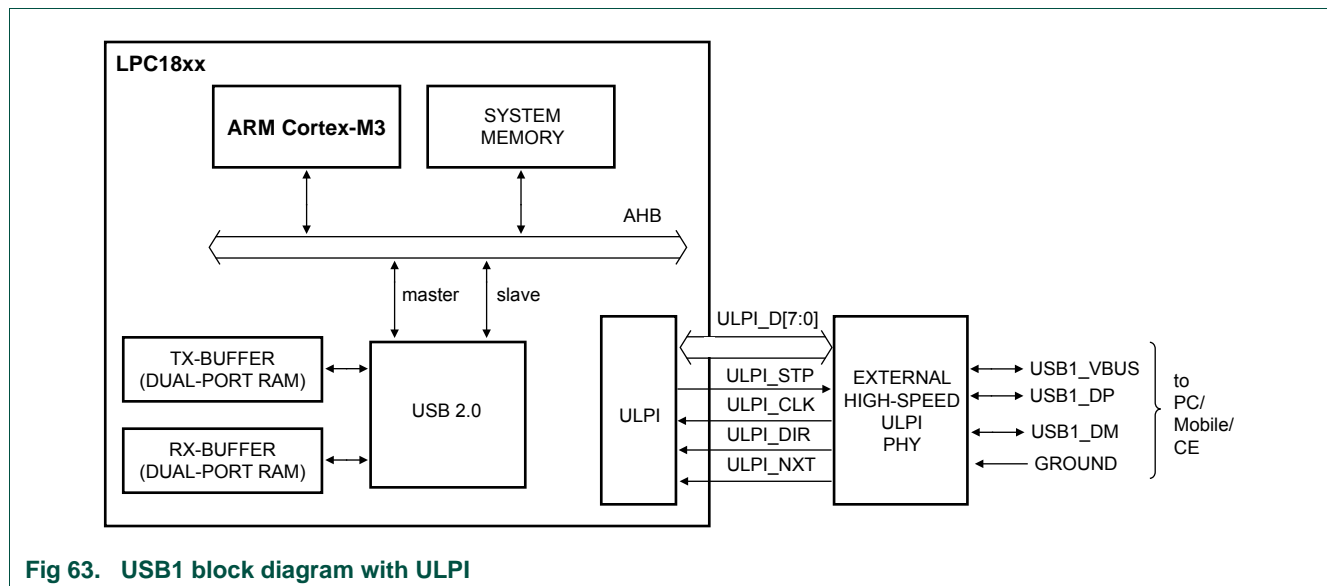

Fig 63. USB1 block diagram with ULPI

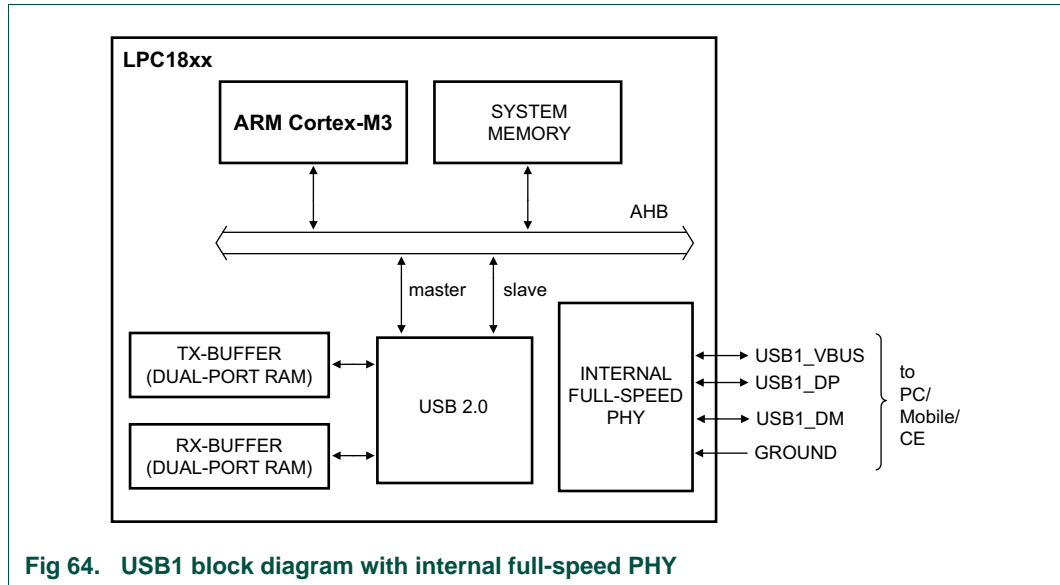

Fig 64. USB1 block diagram with internal full-speed PHY

24.5 Pin description

Table 443. USB1 pin description

Pin function	Direction	Description
USB1_DP	I/O	USB1 bidirectional D+ line. The D+ line has an internal 1.5 kΩ pull-up. This pull-up is enabled when software sets the RS bit (Bit 0) in the USBCMD register. The USB1 controller checks whether the USB1_VBUS pin is pulled HIGH (there is no voltage monitoring). For applications which use the USB1_VBUS pin as GPIO, software can monitor VBUS through bit 5 in SFSUSB register (0x4008 6C80). Add an external series resistor of 33 Ω +/- 2 %.
USB1_DM	I/O	USB1 bidirectional D- line. Add an external series resistor of 33 Ω +/- 2 %.
USB1_VBUS	I	VBUS pin (power on USB cable). If the USB1_VBUS function is not connected on pin P2_5, use the USB_VBUS bit in the SFSUSB register Table 177 to indicate the VBUS state to the USB1 controller. Remark: This input is only 5 V tolerant when VDDIO is present.
USB1_PPWR	O	VBUS drive signal (towards external charge pump or power management unit); indicates that VBUS must be driven (active HIGH). Add a pull-down resistor to disable the power switch at reset. This signal has opposite polarity compared to the USB_PPWR used on other NXP LPC parts.
USB1_IND0	O	Port indicator LED control output 0.
USB1_IND1	O	Port indicator LED control output 1.
USB1_PWR_FAULT	I	Port power fault signal indicating over-current condition; this signal monitors over-current on the USB bus (external circuitry required to detect over-current condition).
ULPI pins		
ULPI_DATA[7:0]	I/O	ULPI link 8-bit bidirectional data bus timed on the rising clock edge.
ULPI_STP	O	ULPI link STP signal. Asserted to end or interrupt transfers to the PHY.
ULPI_NXT	I	ULPI link NXT signal. Data flow control signal from the PHY.
ULPI_DIR	I	ULPI link DIR signal. Controls the DATA bus direction.
ULPI_CLK	I	ULPI link CLK signal. 60 MHz clock generated by the PHY.

Remark: For requirements when connecting the USB1_VBUS signal to a USB powered device-only product or an OTG product, see [Section 23.5.1](#)

24.6 Register description

Remark: For Full-speed operation with on-chip Full-speed PHY, the pads of the PHY need to be configured. For configuration of these pads see [Table 177](#).

Remark: For operations with an external PHY connected through the ULPI interface the interface needs to be selected in the PTS bits of the PORTSC1 register ([Section 24.6.15](#)).

Table 444. Register access abbreviations

Abbreviation	Description
R/W	Read/Write
R/WC	Read/Write one to Clear
R/WO	Read/Write Once
RO	Read Only
WO	Write Only

Table 445. Register overview: USB1 host/device controller (register base address 0x4000 7000)

Name	Access	Address offset	Description	Reset value	Reference
-	-	0x000 - 0x0FF	Reserved		
Device/host capability registers					
CAPLENGTH	RO	0x100	Capability register length	0x0001 0040	Table 446
HCSPARAMS	RO	0x104	Host controller structural parameters	0x0001 0011	Table 447
HCCPARAMS	RO	0x108	Host controller capability parameters	0x0000 0005	Table 448
DCIVERSION	RO	0x120	Device interface version number	0x0000 0001	Table 449
DCCPARAMS	RO	0x124	Device controller capability parameters	0x0000 0184	Table 450
-	-	0x128 - 0x13C	Reserved	-	-
Device/host operational registers					
USBCMD_D	R/W	0x140	USB command (device mode)	0x0004 0000	Table 451
USBCMD_H	R/W	0x140	USB command (host mode)	0x0004 00B0	Table 452
USBSTS_D	R/W	0x144	USB status (device mode)	0x0000 0000	Table 454
USBSTS_H	R/W	0x144	USB status (host mode)	0x0000 1000	Table 455
USBINTR_D	R/W	0x148	USB interrupt enable (device mode)	0x0000 0000	Table 456
USBINTR_H	R/W	0x148	USB interrupt enable (host mode)	0x0000 0000	Table 457
FRINDEX_D	RO	0x14C	USB frame index (device mode)	0x0000 0000	Table 458
FRINDEX_H	R/W	0x14C	USB frame index (host mode)	0x0000 0000	Table 459
-	-	0x150	Reserved		
DEVICEADDR	R/W	0x154	USB device address	0x0000 0000	Table 461
PERIODICLISTBASE	R/W	0x154	Frame list base address	0x0000 0000	Table 462
ENDPOINTLISTADDR	R/W	0x158	Address of endpoint list in memory	0x0000 0000	Table 463
ASYNCLISTADDR	R/W	0x158	Asynchronous list address	0x0000 0000	Table 464

Table 445. Register overview: USB1 host/device controller (register base address 0x4000 7000) ...continued

Name	Access	Address offset	Description	Reset value	Reference
TTCTRL	R/W	0x15C	Asynchronous buffer status for embedded TT (host mode)	0x0000 0000	Table 465
BURSTSIZE	R/W	0x160	Programmable burst size	0x0000 0000	Table 466
TXFILLTUNING	R/W	0x164	Host transmit pre-buffer packet tuning (host mode)	0x0000 0000	Table 467
-	-	0x168 - 0x16C	Reserved	-	-
ULPIVIEWPORT	R/W	0x170	ULPI viewport	0x0000 0000	Table 468
BINTERVAL	R/W	0x174	Length of virtual frame	0x0000 0000	Table 469
ENDPTNAK	R/W	0x178	Endpoint NAK (device mode)	0x0000 0000	Table 470
ENDPTNAKEN	R/W	0x17C	Endpoint NAK Enable (device mode)	0x0000 0000	Table 471
-	-	0x180	-	-	-
PORTSC1_D	R/W	0x184	Port 1 status/control (device mode)	0x0000 0000	Table 472
PORTSC1_H	R/W	0x184	Port 1 status/control (host mode)	0x0000 0000	Table 473
-	-	0x188 - 0x1A0	-	-	-
-	-	0x1A4	-	-	-
USBMODE_D	R/W	0x1A8	USB mode (device mode)	0x0000 0000	Table 475
USBMODE_H	R/W	0x1A8	USB mode (host mode)	0x0000 0000	Table 476
Device endpoint registers					
ENDPTSETUPSTAT	R/W	0x1AC	Endpoint setup status	0x0000 0000	Table 477
ENDPTPRIME	R/W	0x1B0	Endpoint initialization	0x0000 0000	Table 478
ENDPTFLUSH	R/W	0x1B4	Endpoint de-initialization	0x0000 0000	Table 479
ENDPTSTAT	RO	0x1B8	Endpoint status	0x0000 0000	Table 480
ENDPTCOMPLETE	R/W	0x1BC	Endpoint complete	0x0000 0000	Table 481
ENDPTCTRL0	R/W	0x1C0	Endpoint control 0	0x0000 0000	Table 482
ENDPTCTRL1	R/W	0x1C4	Endpoint control 1	0x0000 0000	Table 483
ENDPTCTRL2	R/W	0x1C8	Endpoint control 2	0x0000 0000	Table 483
ENDPTCTRL3	R/W	0x1CC	Endpoint control 3	0x0000 0000	Table 483

24.6.1 Device/host capability registers

Table 446. CAPLENGTH register (CAPLENGTH - address 0x4000 7100) bit description

Bit	Symbol	Description	Reset value	Access
7:0	CAPLENGTH	Indicates offset to add to the register base address at the beginning of the Operational Register	0x40	RO
23:8	HCIVERSION	BCD encoding of the EHCI revision number supported by this host controller.	0x100	RO
31:24	-	These bits are reserved and should be set to zero.	-	-

Table 447. HCSPARAMS register (HCSPARAMS - address 0x4000 7104) bit description

Bit	Symbol	Description	Reset value	Access
3:0	N_PORTS	Number of downstream ports. This field specifies the number of physical downstream ports implemented on this host controller.	0x1	RO
4	PPC	Port Power Control. This field indicates whether the host controller implementation includes port power control.	0x1	RO
7:5	-	These bits are reserved and should be set to zero.	-	-
11:8	N_PCC	Number of Ports per Companion Controller. This field indicates the number of ports supported per internal Companion Controller.	0x0	RO
15:12	N_CC	Number of Companion Controller. This field indicates the number of companion controllers associated with this USB2.0 host controller.	0x0	RO
16	PI	Port indicators. This bit indicates whether the ports support port indicator control.	0x1	RO
19:17	-	These bits are reserved and should be set to zero.	-	-
23:20	N_PTT	Number of Ports per Transaction Translator. This field indicates the number of ports assigned to each transaction translator within the USB2.0 host controller.	0x0	RO
27:24	N_TT	Number of Transaction Translators. This field indicates the number of embedded transaction translators associated with the USB2.0 host controller.	0x0	RO
31:28	-	These bits are reserved and should be set to zero.	-	-

Table 448. HCCPARAMS register (HCCPARAMS - address 0x4000 7108) bit description

Bit	Symbol	Description	Reset value	Access
0	ADC	64-bit Addressing Capability. If zero, no 64-bit addressing capability is supported.	0	RO
1	PFL	Programmable Frame List Flag. If set to one, then the system software can specify and use a smaller frame list and configure the host controller via the USBCMD register Frame List Size field. The frame list must always be aligned on a 4K-boundary. This requirement ensures that the frame list is always physically contiguous.	1	RO
2	ASP	Asynchronous Schedule Park Capability. If this bit is set to a one, then the host controller supports the park feature for high-speed queue heads in the Asynchronous Schedule. The feature can be disabled or enabled and set to a specific level by using the Asynchronous Schedule Park Mode Enable and Asynchronous Schedule Park Mode Count fields in the USBCMD register.	1	RO
7:4	IST	Isochronous Scheduling Threshold. This field indicates, relative to the current position of the executing host controller, where software can reliably update the isochronous schedule.	0	RO
15:8	EECP	EHCI Extended Capabilities Pointer. This optional field indicates the existence of a capabilities list.	0	RO
31:16	-	These bits are reserved and should be set to zero.	-	-

Table 449. DCIVERSION register (DCIVERSION - address 0x4000 7120) bit description

Bit	Symbol	Description	Reset value	Access
15:0	DCIVERSION	The device controller interface conforms to the two-byte BCD encoding of the interface version number contained in this register.	0x1	RO
31:16	-	These bits are reserved and should be set to zero.	-	-

Table 450. DCCPARAMS (address 0x4000 7124)

Bit	Symbol	Description	Reset value	Access
4:0	DEN	Device Endpoint Number.	0x4	RO
6:5	-	These bits are reserved and should be set to zero.	-	-
7	DC	Device Capable.	0x1	RO
8	HC	Host Capable.	0x1	RO
31:9	-	These bits are reserved and should be set to zero.	-	-

24.6.2 USB Command register (USBCMD)

The host/device controller executes the command indicated in this register.

24.6.2.1 Device mode

Table 451. USB Command register in device mode (USBCMD_D - address 0x4000 7140) bit description

Bit	Symbol	Value	Description	Reset value	Access
0	RS		Run/Stop	0	R/W
		0	Writing a 0 to this bit will cause a detach event.		
		1	Writing a one to this bit will cause the device controller to enable a pull-up on USB_DP and initiate an attach event. This control bit is not directly connected to the pull-up enable, as the pull-up will become disabled upon transitioning into high-speed mode. Software should use this bit to prevent an attach event before the device controller has been properly initialized.		
1	RST		Controller reset.	0	R/W
			Software uses this bit to reset the controller. This bit is set to zero by the Host/Device Controller when the reset process is complete. Software cannot terminate the reset process early by writing a zero to this register.		
		0	Set to 0 by hardware when the reset process is complete.		
		1	When software writes a one to this bit, the Device Controller resets its internal pipelines, timers, counters, state machines etc. to their initial values. Writing a one to this bit when the device is in the attached state is not recommended, since the effect on an attached host is undefined. In order to ensure that the device is not in an attached state before initiating a device controller reset, all primed endpoints should be flushed and the USBCMD Run/Stop bit should be set to 0.		
3:2	-	-	Not used in device mode.	0	-
4	-	-	Not used in device mode.	0	-
5	-	-	Not used in device mode.	0	-
6	-	-	Not used in device mode. Writing a one to this bit when the device mode is selected, will have undefined results.	-	-
7	-	-	Reserved. These bits should be set to 0.	-	-
9:8	-	-	Not used in Device mode.	-	-
10	-	-	Reserved. These bits should be set to 0.	0	-
11	-	-	Not used in Device mode.		-
12	-	-	Reserved. These bits should be set to 0.	0	-
13	SUTW		Setup trip wire	0	R/W
			During handling a setup packet, this bit is used as a semaphore to ensure that the setup data payload of 8 bytes is extracted from a QH by the DCD without being corrupted. If the setup lockout mode is off (see USBMODE register) then there exists a hazard when new setup data arrives while the DCD is copying the setup data payload from the QH for a previous setup packet. This bit is set and cleared by software and will be cleared by hardware when a hazard exists. (See Section 23.10).		
14	ATDTW		Add dTD trip wire	0	R/W
			This bit is used as a semaphore to ensure the to proper addition of a new dTD to an active (primed) endpoint's linked list. This bit is set and cleared by software during the process of adding a new dTD. See also Section 23.10 .		
			This bit shall also be cleared by hardware when its state machine is hazard region for which adding a dTD to a primed endpoint may go unrecognized.		

Table 451. USB Command register in device mode (USBCMD_D - address 0x4000 7140) bit description ...continued

Bit	Symbol	Value	Description	Reset value	Access
15	FS2		Not used in device mode.	-	-
23:16	ITC		Interrupt threshold control. The system software uses this field to set the maximum rate at which the host/device controller will issue interrupts. ITC contains the maximum interrupt interval measured in micro-frames. Valid values are shown below. All other values are reserved. 0x0 = Immediate (no threshold) 0x1 = 1 micro frame. 0x2 = 2 micro frames. 0x8 = 8 micro frames. 0x10 = 16 micro frames. 0x20 = 32 micro frames. 0x40 = 64 micro frames.	0x8	R/W
31:24	-		Reserved	0	

24.6.2.2 Host mode

Table 452. USB Command register in host mode (USBCMD_H - address 0x4000 7140) bit description

Bit	Symbol	Value	Description	Reset value	Access
0	RS		Run/Stop	0	R/W
		0	When this bit is set to 0, the Host Controller completes the current transaction on the USB and then halts. The HC Halted bit in the status register indicates when the Host Controller has finished the transaction and has entered the stopped state. Software should not write a one to this field unless the host controller is in the Halted state (i.e. HCHalted in the USBSTS register is a one).		
		1	When set to a 1, the Host Controller proceeds with the execution of the schedule. The Host Controller continues execution as long as this bit is set to a one.		
1	RST		Controller reset. Software uses this bit to reset the controller. This bit is set to zero by the Host/Device Controller when the reset process is complete. Software cannot terminate the reset process early by writing a zero to this register.	0	R/W
		0	This bit is set to zero by hardware when the reset process is complete.		
		1	When software writes a one to this bit, the Host Controller resets its internal pipelines, timers, counters, state machines etc. to their initial value. Any transaction currently in progress on USB is immediately terminated. A USB reset is not driven on downstream ports. Software should not set this bit to a one when the HCHalted bit in the USBSTS register is a zero. Attempting to reset an actively running host controller will result in undefined behavior.		
2	FS0		Bit 0 of the Frame List Size bits. See Table 453 . This field specifies the size of the frame list that controls which bits in the Frame Index Register should be used for the Frame List Current index. Note that this field is made up from USBCMD bits 15, 3, and 2.	0	
3	FS1		Bit 1 of the Frame List Size bits. See Table 453	0	

Table 452. USB Command register in host mode (USBCMD_H - address 0x4000 7140) bit description ...continued

Bit	Symbol	Value	Description	Reset value	Access
4	PSE		This bit controls whether the host controller skips processing the periodic schedule.	0	R/W
		0	Do not process the periodic schedule.		
		1	Use the PERIODICLISTBASE register to access the periodic schedule.		
5	ASE		This bit controls whether the host controller skips processing the asynchronous schedule.	0	R/W
		0	Do not process the asynchronous schedule.		
		1	Use the ASYNCLISTADDR to access the asynchronous schedule.		
6	IAA		This bit is used as a doorbell by software to tell the host controller to issue an interrupt the next time it advances asynchronous schedule.	0	R/W
		0	The host controller sets this bit to zero after it has set the Interrupt on Sync Advance status bit in the USBSTS register to one.		
		1	Software must write a 1 to this bit to ring the doorbell. When the host controller has evicted all appropriate cached schedule states, it sets the Interrupt on Async Advance status bit in the USBSTS register. If the Interrupt on Sync Advance Enable bit in the USBINTR register is one, then the host controller will assert an interrupt at the next interrupt threshold. Software should not write a one to this bit when the asynchronous schedule is inactive. Doing so will yield undefined results.		
7	-	-	Reserved	0	
9:8	ASP1_0		Asynchronous schedule park mode. Contains a count of the number of successive transactions the host controller is allowed to execute from a high-speed queue head on the Asynchronous schedule before continuing traversal of the Asynchronous schedule. Valid values are 0x1 to 0x3. Remark: Software must not write 00 to this bit when Park Mode Enable is one as this will result in undefined behavior.	11	R/W
10	-	-	Reserved.	0	-
11	ASPE		Asynchronous Schedule Park Mode Enable	1	R/W
		0	Park mode is disabled.		
		1	Park mode is enabled.		
12	-	-	Reserved.	0	-
13	-	-	Not used in Host mode.		-
14	-	-	Reserved.	0	-

Table 452. USB Command register in host mode (USBCMD_H - address 0x4000 7140) bit description ...continued

Bit	Symbol	Value	Description	Reset value	Access
15	FS2		Bit 2 of the Frame List Size bits. See Table 453 .	0	-
23:16	ITC		Interrupt threshold control. The system software uses this field to set the maximum rate at which the host/device controller will issue interrupts. ITC contains the maximum interrupt interval measured in micro-frames. Valid values are shown below. All other values are reserved. 0x0 = Immediate (no threshold) 0x1 = 1 micro frame. 0x2 = 2 micro frames. 0x8 = 8 micro frames. 0x10 = 16 micro frames. 0x20 = 32 micro frames. 0x40 = 64 micro frames.	0x8	R/W
31:24	-		Reserved	0	

Table 453. Frame list size values

USBCMD bit 15	USBCMD bit 3	USBCMD bit 2	Frame list size
0	0	0	1024 elements (4096 bytes) - default value
0	0	1	512 elements (2048 bytes)
0	1	0	256 elements (1024 bytes)
0	1	1	128 elements (512 bytes)
1	0	0	64 elements (256 bytes)
1	0	1	32 elements (128 bytes)
1	1	0	16 elements (64 bytes)
1	1	1	8 elements (32 bytes)

24.6.3 USB Status register (USBSTS)

This register indicates various states of the Host/Device controller and any pending interrupts. Software sets a bit to zero in this register by writing a one to it.

Remark: This register does not indicate status resulting from a transaction on the serial bus.

24.6.3.1 Device mode

Table 454. USB Status register in device mode (USBSTS_D - address 0x4000 7144) register bit description

Bit	Symbol	Value	Description	Reset value	Access
0	UI		USB interrupt	0	R/WC
		0	This bit is cleared by software writing a one to it.		
		1	This bit is set by the device controller under the following conditions: <ul style="list-style-type: none"> when the cause of an interrupt is a completion of a USB transaction where the Transfer Descriptor (TD) has an interrupt on complete (IOC) bit set. when a short packet is detected. A short packet is when the actual number of bytes received was less than the expected number of bytes. when a SETUP packet is received. 		
1	UEI		USB error interrupt	0	R/WC
		0	This bit is cleared by software writing a one to it.		
		1	When completion of a USB transaction results in an error condition, this bit is set by the Host/Device Controller. This bit is set along with the USBINT bit, if the TD on which the error interrupt occurred also had its interrupt on complete (IOC) bit set. The device controller detects resume signaling only (see Section 23.10.11.6).		
2	PCI		Port change detect.	0	R/WC
		0	This bit is cleared by software writing a one to it.		
		1	The Device Controller sets this bit to a one when the port controller enters the full or high-speed operational state. When the port controller exits the full or high-speed operation states due to Reset or Suspend events, the notification mechanisms are the USB Reset Received bit (URI) and the DCSuspend bits (SLI) respectively.		
3	-		Not used in Device mode.		
4	SEI	0	System Error The USB Controller sets this bit to 1 when a serious error occurs during a system access involving the USB Controller module. Conditions that set this bit to 1 include AHB Parity error, AHB Master Abort, and AHB Target Abort. When this error occurs, the USB Controller clears the Run/Stop bit in the Command register to prevent further execution of the scheduled TDs.	0	R/WC
5	-		Not used in Device mode.	0	-

Table 454. USB Status register in device mode (USBSTS_D - address 0x4000 7144) register bit description

Bit	Symbol	Value	Description	Reset value	Access
6	URI		USB reset received	0	R/WC
		0	This bit is cleared by software writing a one to it.		
		1	When the device controller detects a USB Reset and enters the default state, this bit will be set to a one.		
7	SRI		SOF received	0	R/WC
		0	This bit is cleared by software writing a one to it.		
		1	When the device controller detects a Start Of (micro) Frame, this bit will be set to a one. When a SOF is extremely late, the device controller will automatically set this bit to indicate that an SOF was expected. Therefore, this bit will be set roughly every 1 ms in device FS mode and every 125 μ s in HS mode and will be synchronized to the actual SOF that is received. Since the device controller is initialized to FS before connect, this bit will be set at an interval of 1ms during the prelude to connect and chirp.		
8	SLI		DCSuspend	0	R/WC
		0	The device controller clears the bit upon exiting from a Suspended state. This bit is cleared by software writing a one to it.		
		1	When a device controller enters a Suspended state from an active state, this bit will be set to a one.		
11:9	-	-	Reserved. Software should only write 0 to reserved bits.	0	
12	-	-	Not used in Device mode.	0	
13	-	-	Not used in Device mode.	0	
14	-	-	Not used in Device mode.	0	
15	-	-	Not used in Device mode.	0	
16	NAKI		NAK interrupt bit	0	RO
		0	This bit is automatically cleared by hardware when the all the enabled TX/RX Endpoint NAK bits are cleared.		
		1	It is set by hardware when for a particular endpoint both the TX/RX Endpoint NAK bit and the corresponding TX/RX Endpoint NAK Enable bit are set.		
17	-	-	Reserved. Software should only write 0 to reserved bits.	0	-
18	-	-	Not used in Device mode.	0	-
19	-	-	Not used in Device mode.	0	-
31:20	-	-	Reserved. Software should only write 0 to reserved bits.		

24.6.3.2 Host mode

Table 455. USB Status register in host mode (USBSTS_H - address 0x4000 7144) register bit description

Bit	Symbol	Value	Description	Reset value	Access
0	UI		USB interrupt (USBINT)	0	R/WC
		0	This bit is cleared by software writing a one to it.		
		1	This bit is set by the Host/Device Controller when the cause of an interrupt is a completion of a USB transaction where the Transfer Descriptor (TD) has an interrupt on complete (IOC) bit set. This bit is also set by the Host/Device Controller when a short packet is detected. A short packet is when the actual number of bytes received was less than the expected number of bytes.		
1	UEI		USB error interrupt (USBERRINT)	0	R/WC
		0	This bit is cleared by software writing a one to it.		
		1	When completion of a USB transaction results in an error condition, this bit is set by the Host/Device Controller. This bit is set along with the USBINT bit, if the TD on which the error interrupt occurred also had its interrupt on complete (IOC) bit set.		
2	PCI		Port change detect.	0	R/WC
		0	This bit is cleared by software writing a one to it.		
		1	The Host Controller sets this bit to a one when on any port a Connect Status occurs, a Port Enable/Disable Change occurs, or the Force Port Resume bit is set as the result of a J-K transition on the suspended port.		
3	FRI		Frame list roll-over	0	R/WC
		0	This bit is cleared by software writing a one to it.		
		1	The Host Controller sets this bit to a one when the Frame List Index rolls over from its maximum value to zero. The exact value at which the rollover occurs depends on the frame list size. For example, if the frame list size (as programmed in the Frame List Size field of the USBCMD register) is 1024, the Frame Index Register rolls over every time FRINDEX [13] toggles. Similarly, if the size is 512, the Host Controller sets this bit to a one every time FRINDEX bit 12 toggles (see Section 24.6.5).		
4	SEI	0	System Error The USB Controller sets this bit to 1 when a serious error occurs during a system access involving the USB Controller module. Conditions that set this bit to 1 include AHB Parity error, AHB Master Abort, and AHB Target Abort. When this error occurs, the USB Controller clears the Run/Stop bit in the Command register to prevent further execution of the scheduled TDs.	0	R/WC
5	AAI		Interrupt on async advance	0	R/WC
		0	This bit is cleared by software writing a one to it.		
		1	System software can force the host controller to issue an interrupt the next time the host controller advances the asynchronous schedule by writing a one to the Interrupt on Async Advance Doorbell bit in the USBCMD register. This status bit indicates the assertion of that interrupt source.		
6	-	-	Not used by the Host controller.	0	R/WC
7	SRI		SOF received	0	R/WC
		0	This bit is cleared by software writing a one to it.		
		1	In host mode, this bit will be set every 125 μ s and can be used by host controller driver as a time base.		

Table 455. USB Status register in host mode (USBSTS_H - address 0x4000 7144) register bit description ...continued

Bit	Symbol	Value	Description	Reset value	Access
8	SLI	-	Not used by the Host controller.	-	-
11:9	-	-	Reserved.		
12	HCH		HCHalted	1	RO
		0	The RS bit in USBCMD is set to zero. Set by the host controller.		
		1	The Host Controller sets this bit to one after it has stopped executing because of the Run/Stop bit being set to 0, either by software or by the Host Controller hardware (e.g. because of an internal error).		
13	RCL		Reclamation	0	RO
		0	No empty asynchronous schedule detected.		
		1	An empty asynchronous schedule is detected. Set by the host controller.		
14	PS		Periodic schedule status	0	RO
			This bit reports the current real status of the Periodic Schedule. The Host Controller is not required to immediately disable or enable the Periodic Schedule when software transitions the Periodic Schedule Enable bit in the USBCMD register. When this bit and the Periodic Schedule Enable bit are the same value, the Periodic Schedule is either enabled (if both are 1) or disabled (if both are 0).		
		0	The periodic schedule status is disabled.		
	1	The periodic schedule status is enabled.			
15	AS		Asynchronous schedule status	0	
			This bit reports the current real status of the Asynchronous Schedule. The Host Controller is not required to immediately disable or enable the Asynchronous Schedule when software transitions the Asynchronous Schedule Enable bit in the USBCMD register. When this bit and the Asynchronous Schedule Enable bit are the same value, the Asynchronous Schedule is either enabled (if both are 1) or disabled (if both are 0).		
		0	Asynchronous schedule status is disabled.		
	1	Asynchronous schedule status is enabled.			
16	-		Not used on Host mode.	0	-
17	-		Reserved.		
18	UAI		USB host asynchronous interrupt (USBHSTASYNCINT)	0	R/WC
		0	This bit is cleared by software writing a one to it.		
		1	This bit is set by the Host Controller when the cause of an interrupt is a completion of a USB transaction where the Transfer Descriptor (TD) has an interrupt on complete (IOC) bit set and the TD was from the asynchronous schedule. This bit is also set by the Host when a short packet is detected and the packet is on the asynchronous schedule. A short packet is when the actual number of bytes received was less than the expected number of bytes.		

Table 455. USB Status register in host mode (USBSTS_H - address 0x4000 7144) register bit description ...continued

Bit	Symbol	Value	Description	Reset value	Access
19	UPI		USB host periodic interrupt (USBHSTPERINT)	0	R/WC
		0	This bit is cleared by software writing a one to it.		
		1	This bit is set by the Host Controller when the cause of an interrupt is a completion of a USB transaction where the Transfer Descriptor (TD) has an interrupt on complete (IOC) bit set and the TD was from the periodic schedule. This bit is also set by the Host Controller when a short packet is detected and the packet is on the periodic schedule. A short packet is when the actual number of bytes received was less than the expected number of bytes.		
31:20	-		Reserved.	-	-

24.6.4 USB Interrupt register (USBINTR)

The software interrupts are enabled with this register. An interrupt is generated when a bit is set and the corresponding interrupt is active. The USB Status register (USBSTS) still shows interrupt sources even if they are disabled by the USBINTR register, allowing polling of interrupt events by the software. All interrupts must be acknowledged by software by clearing (that is writing a 1 to) the corresponding bit in the USBSTS register.

24.6.4.1 Device mode

Table 456. USB Interrupt register in device mode (USBINTR_D - address 0x4000 7148) bit description

Bit	Symbol	Description	Reset value	Access
0	UE	USB interrupt enable When this bit is one, and the USBINT bit in the USBSTS register is one, the host/device controller will issue an interrupt at the next interrupt threshold. The interrupt is acknowledged by software clearing the USBINT bit in USBSTS.	0	R/W
1	UEE	USB error interrupt enable When this bit is a one, and the USBERRINT bit in the USBSTS register is a one, the host/device controller will issue an interrupt at the next interrupt threshold. The interrupt is acknowledged by software clearing the USBERRINT bit in the USBSTS register.	0	R/W
2	PCE	Port change detect enable When this bit is a one, and the Port Change Detect bit in the USBSTS register is a one, the host/device controller will issue an interrupt. The interrupt is acknowledged by software clearing the Port Change Detect bit in USBSTS.	0	R/W
3	-	Not used by the Device controller.		
4	SEE	System Error Enable When this bit is a one, and the System Error bit in the USBSTS register is a one, the host/device controller will issue an interrupt. The interrupt is acknowledged by software clearing the System Error bit in USBSTS register.	0	R/W
5	-	Not used by the Device controller.		
6	URE	USB reset enable When this bit is a one, and the USB Reset Received bit in the USBSTS register is a one, the device controller will issue an interrupt. The interrupt is acknowledged by software clearing the USB Reset Received bit.	0	R/W

Table 456. USB Interrupt register in device mode (USBINTR_D - address 0x4000 7148) bit description ...continued

Bit	Symbol	Description	Reset value	Access
7	SRE	SOF received enable When this bit is a one, and the SOF Received bit in the USBSTS register is a one, the device controller will issue an interrupt. The interrupt is acknowledged by software clearing the SOF Received bit.	0	R/W
8	SLE	Sleep enable When this bit is a one, and the DCSuspend bit in the USBSTS register transitions, the device controller will issue an interrupt. The interrupt is acknowledged by software writing a one to the DCSuspend bit.	0	R/W
15:9	-	Reserved	-	-
16	NAKE	NAK interrupt enable This bit is set by software if it wants to enable the hardware interrupt for the NAK Interrupt bit. If both this bit and the corresponding NAK Interrupt bit are set, a hardware interrupt is generated.	0	R/W
17	-	Reserved		
18	UAIE	Not used by the Device controller.		
19	UPIA	Not used by the Device controller.		
31:20	-	Reserved		

24.6.4.2 Host mode

Table 457. USB Interrupt register in host mode (USBINTR_H - address 0x4000 7148) bit description

Bit	Symbol	Description	Access	Reset value
0	UE	USB interrupt enable When this bit is one, and the USBINT bit in the USBSTS register is one, the host/device controller will issue an interrupt at the next interrupt threshold. The interrupt is acknowledged by software clearing the USBINT bit in USBSTS.	R/W	0
1	UEE	USB error interrupt enable When this bit is a one, and the USBERRINT bit in the USBSTS register is a one, the host/device controller will issue an interrupt at the next interrupt threshold. The interrupt is acknowledged by software clearing the USBERRINT bit in the USBSTS register.	R/W	0
2	PCE	Port change detect enable When this bit is a one, and the Port Change Detect bit in the USBSTS register is a one, the host/device controller will issue an interrupt. The interrupt is acknowledged by software clearing the Port Change Detect bit in USBSTS.	R/W	0
3	FRE	Frame list rollover enable When this bit is a one, and the Frame List Rollover bit in the USBSTS register is a one, the host controller will issue an interrupt. The interrupt is acknowledged by software clearing the Frame List Rollover bit.		
4	SEE	System Error Enable When this bit is a one, and the System Error bit in the USBSTS register is a one, the host/device controller will issue an interrupt. The interrupt is acknowledged by software clearing the System Error bit in USBSTS register.	R/W	0

Table 457. USB Interrupt register in host mode (USBINTR_H - address 0x4000 7148) bit description ...continued

Bit	Symbol	Description	Access	Reset value
5	AAE	Interrupt on asynchronous advance enable When this bit is a one, and the Interrupt on Async Advance bit in the USBSTS register is a one, the host controller will issue an interrupt at the next interrupt threshold. The interrupt is acknowledged by software clearing the Interrupt on Async Advance bit.	R/W	0
6	-	Not used by the Host controller.	-	0
7	SRE	If this bit is one and the SRI bit in the USBSTS register is one, the host controller will issue an interrupt. In host mode, the SRI bit will be set every 125 μ s and can be used by the host controller as a time base. The interrupt is acknowledged by software clearing the SRI bit in the USBSTS register.	-	0
8	-	Not used by the Host controller.	-	0
15:9	-	Reserved		
16	-	Not used by the host controller.	R/W	0
17	-	Reserved		
18	UAIE	USB host asynchronous interrupt enable When this bit is a one, and the USBHSTASYNCINT bit in the USBSTS register is a one, the host controller will issue an interrupt at the next interrupt threshold. The interrupt is acknowledged by software clearing the USBHSTASYNCINT bit.	R/W	0
19	UPIA	USB host periodic interrupt enable When this bit is a one, and the USBHSTPERINT bit in the USBSTS register is a one, the host controller will issue an interrupt at the next interrupt threshold. The interrupt is acknowledged by software clearing the USBHSTPERINT bit.	R/W	0
31:20	-	Reserved		

24.6.5 Frame index register (FRINDEX)

24.6.5.1 Device mode

In Device mode this register is read only, and the device controller updates the FRINDEX[13:3] register from the frame number indicated by the SOF marker. Whenever a SOF is received by the USB bus, FRINDEX[13:3] will be checked against the SOF marker. If FRINDEX[13:3] is different from the SOF marker, FRINDEX[13:3] will be set to the SOF value and FRINDEX[2:0] will be set to zero (i.e. SOF for 1 ms frame). If FRINDEX [13:3] is equal to the SOF value, FRINDEX[2:0] will be incremented (i.e. SOF for 125 μ s micro-frame) by hardware.

Table 458. USB frame index register in device mode (FRINDEX_D - address 0x4000 714C) bit description

Bit	Symbol	Description	Reset value	Access
2:0	FRINDEX2_0	Current micro frame number	-	RO
13:3	FRINDEX13_3	Current frame number of the last frame transmitted	-	RO
31:14	-	Reserved	-	

24.6.5.2 Host mode

This register is used by the host controller to index the periodic frame list. The register updates every 125 μ s (once each micro-frame). Bits[N: 3] are used to select a particular entry in the Periodic Frame List during periodic schedule execution. The number of bits used for the index depends on the size of the frame list as set by system software in the Frame List Size field in the USBCMD register.

This register must be written as a DWord. Byte writes produce undefined results. This register cannot be written unless the Host Controller is in the 'Halted' state as indicated by the HCHalted bit in the USBSTS register (host mode). A write to this register while the Run/Stop bit is set to a one produces undefined results. Writes to this register also affect the SOF value.

Table 459. USB frame index register in host mode (FRINDEX_H - address 0x4000 714C) bit description

Bit	Symbol	Description	Reset value	Access
2:0	FRINDEX2_0	Current micro frame number	-	R/W
12:3	FRINDEX12_3	Frame list current index for 1024 elements.	-	R/W
31:13	-	Reserved	-	

Table 460. Number of bits used for the frame list index

USBCMD bit 15	USBCMD bit 3	USBCMD bit 2	Frame list size	Size of FRINDEX12_3 bit field
0	0	0	1024 elements (4096 bytes). Default value.	12
0	0	1	512 elements (2048 bytes)	11
0	1	0	256 elements (1024 bytes)	10
0	1	1	128 elements (512 bytes)	9
1	0	0	64 elements (256 bytes)	8
1	0	1	32 elements (128 bytes)	7
1	1	0	16 elements (64 bytes)	6
1	1	1	8 elements (32 bytes)	5

24.6.6 Device address (DEVICEADDR) and Periodic List Base (PERIODICLISTBASE) registers

24.6.6.1 Device mode

The upper seven bits of this register represent the device address. After any controller reset or a USB reset, the device address is set to the default address (0). The default address will match all incoming addresses. Software shall reprogram the address after receiving a SET_ADDRESS descriptor.

The USBADRA bit is used to accelerate the SET_ADDRESS sequence by allowing the DCD to preset the USBADR register bits before the status phase of the SET_ADDRESS descriptor.

Table 461. USB Device Address register in device mode (DEVICEADDR - address 0x4000 7154) bit description

Bit	Symbol	Value	Description	Reset value	Access
23:0	-		reserved	0	-
24	USBADRA		Device address advance		
		0	Any write to USBADR are instantaneous.		
		1	When the user writes a one to this bit at the same time or before USBADR is written, the write to USBADR fields is staged and held in a hidden register. After an IN occurs on endpoint 0 and is acknowledged, USBADR will be loaded from the holding register. Hardware will automatically clear this bit on the following conditions: <ul style="list-style-type: none"> • IN is ACKed to endpoint 0. USBADR is updated from the staging register. • OUT/SETUP occurs on endpoint 0. USBADR is not updated. • Device reset occurs. USBADR is set to 0. Remark: After the status phase of the SET_ADDRESS descriptor, the DCD has 2 ms to program the USBADR field. This mechanism will ensure this specification is met when the DCD can not write the device address within 2 ms from the SET_ADDRESS status phase. If the DCD writes the USBADR with USBADRA=1 after the SET_ADDRESS data phase (before the prime of the status phase), the USBADR will be programmed instantly at the correct time and meet the 2 ms USB requirement.		
31:25	USBADR		USB device address	0	R/W

24.6.6.2 Host mode

This 32-bit register contains the beginning address of the Periodic Frame List in the system memory. The host controller driver (HCD) loads this register prior to starting the schedule execution by the Host Controller. The memory structure referenced by this physical memory pointer is assumed to be 4 kB aligned. The contents of this register are combined with the Frame Index Register (FRINDEX) to enable the Host Controller to step through the Periodic Frame List in sequence.

Table 462. USB Periodic List Base register in host mode (PERIODICLISTBASE - address 0x4000 7154) bit description

Bit	Symbol	Description	Reset value	Access
11:0	-	Reserved	N/A	-
31:12	PERBASE31_12	Base Address (Low) These bits correspond to the memory address signals[31:12].	N/A	R/W

24.6.7 Endpoint List Address register (ENDPOINTLISTADDR) and Asynchronous List Address (ASYNCLISTADDR) registers

24.6.7.1 Device mode

In device mode, this register contains the address of the top of the endpoint list in system memory. Bits[10:0] of this register cannot be modified by the system software and will always return a zero when read. The memory structure referenced by this physical memory pointer is assumed 64 byte aligned.

Table 463. USB Endpoint List Address register in device mode (ENDPOINTLISTADDR - address 0x4000 7158) bit description

Bit	Symbol	Description	Reset value	Access
10:0	-	reserved	0	-
31:11	EPBASE31_11	Endpoint list pointer (low) These bits correspond to memory address signals 31:11, respectively. This field will reference a list of up to 8 Queue Heads (QH). (i.e. one queue head per endpoint and direction.)	N/A	R/W

24.6.7.2 Host mode

This 32-bit register contains the address of the next asynchronous queue head to be executed by the host. Bits [4:0] of this register cannot be modified by the system software and will always return a zero when read.

Table 464. USB Asynchronous List Address register in host mode (ASYNCLISTADDR- address 0x4000 7158) bit description

Bit	Symbol	Description	Reset value	Access
4:0	-	Reserved	0	-
31:5	ASYBASE31_5	Link pointer (Low) LPL These bits correspond to memory address signals 31:5, respectively. This field may only reference a Queue Head (OH).	-	R/W

24.6.8 TT Control register (TTCTRL)

24.6.8.1 Device mode

This register is not used in device mode.

24.6.8.2 Host mode

This register contains parameters needed for internal TT operations. This register is used by the host controller only. Writes must be in Dwords.

Table 465. USB TT Control register in host mode (TTCTRL - address 0x4000 715C) bit description

Bit	Symbol	Description	Reset value	Access
23:0	-	Reserved.	0	-
30:24	TTHA	Hub address when FS or LS device are connected directly.	N/A	R/W
31	-	Reserved.	0	

24.6.9 Burst Size register (BURSTSIZE)

This register is used to control and dynamically change the burst size used during data movement on the master interface of the USB DMA controller. Writes must be in Dwords.

The default for the length of a burst of 32-bit words for RX and TX DMA data transfers is 16 words each.

Table 466. USB burst size register in device/host mode (BURSTSIZE - address 0x4000 7160) bit description

Bit	Symbol	Description	Reset value	Access
7:0	RXPBURST	Programmable RX burst length This register represents the maximum length of a burst in 32-bit words while moving data from the USB bus to system memory.	0x10	R/W
15:8	TXPBURST	Programmable TX burst length This register represents the maximum length of a burst in 32-bit words while moving data from system memory to the USB bus.	0x10	R/W
31:16	-	reserved	-	-

24.6.10 Transfer buffer Fill Tuning register (TXFILLTUNING)

24.6.10.1 Device controller

This register is not used in device mode.

24.6.10.2 Host controller

The fields in this register control performance tuning associated with how the host controller posts data to the TX latency FIFO before moving the data onto the USB bus. The specific areas of performance include the how much data to post into the FIFO and an estimate for how long that operation should take in the target system.

Definitions:

T_0 = Standard packet overhead

T_1 = Time to send data payload

T_{ff} = Time to fetch packet into TX FIFO up to specified level

T_s = Total packet flight time (send-only) packet; $T_s = T_0 + T_1$

T_p = Total packet time (fetch and send) packet; $T_p = T_{ff} + T_0 + T_1$

Upon discovery of a transmit (OUT/SETUP) packet in the data structures, host controller checks to ensure T_p remains before the end of the (micro) frame. If so it proceeds to pre-fill the TX FIFO. If at anytime during the pre-fill operation the time remaining the [micro]frame is $< T_s$ then the packet attempt ceases and the packet is tried at a later time. Although this is not an error condition and the host controller will eventually recover, a mark will be made the scheduler health counter to note the occurrence of a “backoff” event. When a back-off event is detected, the partial packet fetched may need to be discarded from the latency buffer to make room for periodic traffic that will begin after the next SOF. Too many back-off events can waste bandwidth and power on the system bus and thus should be minimized (not necessarily eliminated). Backoffs can be minimized with use of the TSCHEALTH (T_{ff}) described below.

Table 467. USB Transfer buffer Fill Tuning register in host mode (TXFILLTUNING - address 0x4000 7164) bit description

Bit	Symbol	Description	Reset value	Access
7:0	TXSCHOH	FIFO burst threshold This register controls the number of data bursts that are posted to the TX latency FIFO in host mode before the packet begins on to the bus. The minimum value is 2 and this value should be as low as possible to maximize USB performance. A higher value can be used in systems with unpredictable latency and/or insufficient bandwidth where the FIFO may underrun because the data transferred from the latency FIFO to USB occurs before it can be replenished from system memory. This value is ignored if the Stream Disable bit in USBMODE register is set.	0x2	R/W
12:8	TXSCHEALTH	Scheduler health counter This register increments when the host controller fails to fill the TX latency FIFO to the level programmed by TXFIFOTHRES before running out of time to send the packet before the next Start-Of-Frame . This health counter measures the number of times this occurs to provide feedback to selecting a proper TXSCHOH. Writing to this register will clear the counter. The maximum value is 31.	0x0	R/W
15:13	-	Reserved	-	-
21:16	TXFIFOTHRES	Scheduler overhead This register adds an additional fixed offset to the schedule time estimator described above as T_{ff} . As an approximation, the value chosen for this register should limit the number of back-off events captured in the TXSCHHEALTH to less than 10 per second in a highly utilized bus. Choosing a value that is too high for this register is not desired as it can needlessly reduce USB utilization. The time unit represented in this register is 1.267 μ s when a device is connected in High-Speed Mode. The time unit represented in this register is 6.333 μ s when a device is connected in Low/Full Speed Mode.	0x0	R/W
31:22	-	Reserved		

24.6.11 USB ULPI viewport register (ULPIVIEWPORT)

The register provides indirect access to the ULPI PHY register set. Although the core performs access to the ULPI PHY register set, there may be extraordinary circumstances where software may need direct access.

Remark: Writes to the ULPI through the viewport can substantially harm standard USB operations. Currently no usage model has been defined where software should need to execute writes directly to the ULPI – see exception regarding optional features below.

Remark: Executing read operations through the ULPI viewport should have no harmful side effects to standard USB operations.

There are two operations that can be performed with the ULPI Viewport, wake-up and read/write operations. The wakeup operation is used to put the ULPI interface into normal operation mode and reenable the clock if necessary. A wakeup operation is required before accessing the registers when the ULPI interface is operating in low power mode, serial mode, or carkit mode. The ULPI state can be determined by reading the sync. state bit (ULPISS). If this bit is a one, then ULPI interface is running in normal operation mode and can accept read/write operations. If the ULPISS indicates a 0 then read/write

operations will not be able execute. Undefined behavior will result if ULPISS = 0 and a read or write operation is performed. To execute a wakeup operation, write all 32-bits of the ULPI Viewport where ULPIPORT is constructed appropriately and the ULPIWU bit is a 1 and ULPIRUN bit is a 0. Poll the ULPI Viewport until ULPIWU is zero for the operation to complete.

To execute a read or write operation, write all 32-bits of the ULPI Viewport where ULPIDATWR, ULPIADDR, ULPIPORT, ULPIRW are constructed appropriately and the ULPIRUN bit is a 1. Poll the ULPI Viewport until ULPIRUN is zero for the operation to complete. Once ULPIRUN is zero, the ULPIDATRD will be valid if the operation was a read.

The polling method above could also be replaced and interrupt driven using the ULPI interrupt defined in the USBSTS and USBINTR registers. When a wakeup or read/write operation complete, the ULPI interrupt will be set.

Table 468. USB ULPI viewport register (ULPIVIEWPORT - address 0x4000 7170) bit description

Bit	Symbol	Value	Description	Access	Reset value
7:0	ULPIDATWR		When a write operation is commanded, the data to be sent is written to this field.	R/W	0
15:8	ULPIDATRD		After a read operation completes, the result is placed in this field.	R	0
23:16	ULPIADDR		When a read or write operation is commanded, the address of the operation is written to this field.	R/W	0
26:24	ULPIPORT		For the wakeup or read/write operation to be executed, this value must be written as 0.	R/W	000
27	ULPISS		ULPI sync state. This bit represents the state of the ULPI interface.	R	0
		0	In another state (ie. carkit, serial, low power)		
		1	Normal Sync. State.		
28	-	-	Reserved	-	-
29	ULPIRW		ULPI Read/Write control. This bit selects between running a read or write operation.	R/W	0
		0	Read		
		1	Write		
30	ULPIRUN		ULPI Read/Write Run.	R/W	-
			Writing the 1 to this bit will begin the read/write operation. The bit will automatically transition to 0 after the read/write is complete. Once this bit is set, the driver can not set it back to 0. Remark: The driver must never execute a wake-up and a read/write operation at the same time.		
31	ULPIWU		ULPI Wake-up.	R/W	0
			Writing the 1 to this bit will begin the wake-up operation. The bit will automatically transition to 0 after the wake-up is complete. Once this bit is set, the driver can not set it back to 0. Remark: The driver must never execute a wake-up and a read/write operation at the same time.		

24.6.12 BINTERVAL register

This register defines the bInterval value which determines the length of the virtual frame (see [Section 23.7.7](#)).

Remark: The BINTERVAL register is not related to the bInterval endpoint descriptor field in the USB specification.

Table 469. USB BINTERVAL register (BINTERVAL - address 0x4000 7174) bit description in device/host mode

Bit	Symbol	Description	Reset value	Access
3:0	BINT	bInterval value	0x00	R/W
31:4	-	Reserved	-	-

24.6.13 USB Endpoint NAK register (ENDPTNAK)

24.6.13.1 Device mode

This register indicates when the device sends a NAK handshake on an endpoint. Each Tx and Rx endpoint has a bit in the EPTN and EPRN field respectively.

A bit in this register is cleared by writing a 1 to it.

Table 470. USB endpoint NAK register in device mode (ENDPTNAK - address 0x4000 7178) bit description

Bit	Symbol	Description	Reset value	Access
3:0	EPRN	Rx endpoint NAK Each RX endpoint has one bit in this field. The bit is set when the device sends a NAK handshake on a received OUT or PING token for the corresponding endpoint. Bit 3 corresponds to endpoint 3. ... Bit 1 corresponds to endpoint 1. Bit 0 corresponds to endpoint 0.	0x00	R/WC
15:6	-	Reserved	-	-
19:16	EPTN	Tx endpoint NAK Each TX endpoint has one bit in this field. The bit is set when the device sends a NAK handshake on a received IN token for the corresponding endpoint. Bit 3 corresponds to endpoint 3. ... Bit 1 corresponds to endpoint 1. Bit 0 corresponds to endpoint 0.	0x00	R/WC
31:20	-	Reserved	-	-

24.6.13.2 Host mode

This register is not used in host mode.

24.6.14 USB Endpoint NAK Enable register (ENDPTNAKEN)

24.6.14.1 Device mode

Each bit in this register enables the corresponding bit in the ENDPTNAK register. Each Tx and Rx endpoint has a bit in the EPTNE and EPRNE field respectively.

Table 471. USB Endpoint NAK Enable register in device mode (ENDPTNAKEN - address 0x4000 717C) bit description

Bit	Symbol	Description	Reset value	Access
3:0	EPRNE	Rx endpoint NAK enable Each bit enables the corresponding RX NAK bit. If this bit is set and the corresponding RX endpoint NAK bit is set, the NAK interrupt bit is set. Bit 3 corresponds to endpoint 3. ... Bit 1 corresponds to endpoint 1. Bit 0 corresponds to endpoint 0.	0x00	R/W
15:4	-	Reserved	-	-
19:16	EPTNE	Tx endpoint NAK Each bit enables the corresponding TX NAK bit. If this bit is set and the corresponding TX endpoint NAK bit is set, the NAK interrupt bit is set. Bit 3 corresponds to endpoint 3. ... Bit 1 corresponds to endpoint 1. Bit 0 corresponds to endpoint 0.	0x00	R/W
31:20	-	Reserved	-	-

24.6.14.2 Host mode

This register is not used in host mode.

24.6.15 Port Status and Control register (PORTSC1)

24.6.15.1 Device mode

The device controller implements one port register, and it does not support power control. Port control in device mode is used for status port reset, suspend, and current connect status. It is also used to initiate test mode or force signaling. This register allows software to put the PHY into low-power Suspend mode and disable the PHY clock.

Table 472. Port Status and Control register in device mode (PORTSC1_D - address 0x4000 7184) bit description

Bit	Symbol	Value	Description	Reset value	Access
0	CCS		Current connect status	0	RO
		0	Device not attached A zero indicates that the device did not attach successfully or was forcibly disconnected by the software writing a zero to the Run bit in the USB_CMD register. It does not state the device being disconnected or suspended.		
		1	Device attached. A one indicates that the device successfully attached and is operating in either high-speed mode or full-speed mode as indicated by the High Speed Port bit in this register.		
1	CSC	-	Not used in device mode	0	-
2	PE	1	Port enable. This bit is always 1. The device port is always enabled.	1	RO
3	PEC	0	Port enable/disable change This bit is always 0. The device port is always enabled.	0	RO
5:4	-	-	Reserved	0	RO
6	FPR		Force port resume After the device has been in Suspended state for 5 ms or more, software must set this bit to one to drive resume signaling before clearing. The Device Controller will set this bit to one if a J-to-K transition is detected while the port is in the Suspended state. The bit will be cleared when the device returns to normal operation. When this bit transitions to a one because a J-to-K transition detected, the Port Change Detect bit in the USBSTS register is set to one as well.	0	R/W
		0	No resume (K-state) detected/driven on port.		
		1	Resume detected/driven on port.		
7	SUSP		Suspend In device mode, this is a read-only status bit .	0	RO
		0	Port not in Suspended state		
		1	Port in Suspended state		
8	PR		Port reset In device mode, this is a read-only status bit. A device reset from the USB bus is also indicated in the USBSTS register.	0	RO
		0	Port is not in the reset state.		
		1	Port is in the reset state.		
9	HSP		High-speed status Remark: This bit is redundant with bits 27:26 (PSPD) in this register. It is implemented for compatibility reasons.	0	RO
		0	Host/device connected to the port is not in High-speed mode.		
		1	Host/device connected to the port is in High-speed mode.		
11:10	LS	-	Not used in device mode.		
12	PP	-	Not used in device mode.		
13	-	-	Reserved	-	-

Table 472. Port Status and Control register in device mode (PORTSC1_D - address 0x4000 7184) bit description

Bit	Symbol	Value	Description	Reset value	Access
15:14	PIC1_0		Port indicator control Writing to this field effects the value of the USB1_IND1:0 pins.	00	R/W
		0x0	Port indicators are off.		
		0x1	amber		
		0x2	green		
		0x3	undefined		
19:16	PTC3_0		Port test control Any value other than 0000 indicates that the port is operating in test mode. The FORCE_ENABLE_FS and FORCE_ENABLE_LS are extensions to the test mode support specified in the EHCI specification. Writing the PTC field to any of the FORCE_ENABLE_HS/FS/LS values will force the port into the connected and enabled state at the selected speed. Writing the PTC field back to TEST_MODE_DISABLE will allow the port state machines to progress normally from that point. Values 0x7 to 0xF are reserved.	0000	R/W
		0x0	TEST_MODE_DISABLE		
		0x1	J_STATE		
		0x2	K_STATE		
		0x3	SE0 (host)/NAK (device)		
		0x4	Packet		
		0x5	FORCE_ENABLE_HS		
		0x6	FORCE_ENABLE_FS		
20	-	-	Not used in device mode. This bit is always 0 in device mode.	0	-
21	-	-	Not used in device mode. This bit is always 0 in device mode.	0	-
22	-	-	Not used in device mode. This bit is always 0 in device mode.	0	-
23	PHCD		PHY low power suspend - clock disable (PLPSCD) In device mode, The PHY can be put into Low Power Suspend – Clock Disable when the device is not running (USBCMD Run/Stop = 0) or the host has signaled suspend (PORTSC SUSPEND = 1). Low power suspend will be cleared automatically when the host has signaled resume. Before forcing a resume from the device, the device controller driver must clear this bit.	0	R/W
		0	Writing a 0 enables the PHY clock. Reading a 0 indicates the status of the PHY clock (enabled).		
		1	Writing a 1 disables the PHY clock. Reading a 1 indicates the status of the PHY clock (disabled).		
24	PFSC		Port force full speed connect	0	R/W
		0	Port connects at any speed.		
		1	Writing this bit to a 1 will force the port to only connect at full speed. It disables the chirp sequence that allows the port to identify itself as High-speed. This is useful for testing FS configurations with a HS host, hub or device.		
25	-	-	Reserved		

Table 472. Port Status and Control register in device mode (PORTSC1_D - address 0x4000 7184) bit description

Bit	Symbol	Value	Description	Reset value	Access
27:26	PSPD		Port speed This register field indicates the speed at which the port is operating.	0	RO
		0x1	Full-speed		
		0x2	invalid in device mode		
		0x3	High-speed		
29:28	-	-	Reserved	-	-
31:30	PTS		Parallel transceiver select. All other values are reserved.	-	R/W
		0x2	ULPI		
		0x3	Serial/ 1.1 PHY (Full-speed only)		

24.6.15.2 Host mode

The host controller uses one port. The register is only reset when power is initially applied or in response to a controller reset. The initial conditions of the port are:

- No device connected
- Port disabled

If the port has power control, this state remains until software applies power to the port by setting port power to one in the PORTSC register.

Table 473. Port Status and Control register in host mode (PORTSC1_H - address 0x4000 7184) bit description

Bit	Symbol	Value	Description	Reset value	Access
0	CCS		Current connect status This value reflects the current state of the port and may not correspond directly to the event that caused the CSC bit to be set. This bit is 0 if PP (Port Power bit) is 0. Software clears this bit by writing a 1 to it.	0	R/WC
		0	No device is present.		
		1	Device is present on the port.		
1	CSC		Connect status change Indicates a change has occurred in the port's Current Connect Status. The host/device controller sets this bit for all changes to the port device connect status, even if system software has not cleared an existing connect status change. For example, the insertion status changes twice before system software has cleared the changed condition, hub hardware will be 'setting' an already-set bit (i.e., the bit will remain set). Software clears this bit by writing a one to it. This bit is 0 if PP (Port Power bit) is 0	0	R/WC
		0	No change in current status.		
		1	Change in current status.		

Table 473. Port Status and Control register in host mode (PORTSC1_H - address 0x4000 7184) bit description
...continued

Bit	Symbol	Value	Description	Reset value	Access
2	PE		Port enable.	0	R/W
		0	Port disabled.		
		1	Port enabled.		
3	PEC	0	Port disable/enable change	0	R/WC
			For the root hub, this bit gets set to a one only when a port is disabled due to disconnect on the port or due to the appropriate conditions existing at the EOF2 point (See <i>Chapter 11 of the USB Specification</i>). Software clears this by writing a one to it. This bit is 0 if PP (Port Power bit) is 0,		
		0	No change.		
		1	Port enabled/disabled status has changed.		
4	OCA		Over-current active	0	RO
			This bit will automatically transition from 1 to 0 when the over-current condition is removed.		
		0	The port does not have an over-current condition.		
		1	The port has currently an over-current condition.		
5	OCC		Over-current change	0	R/WC
			This bit gets set to one when there is a change to Over-current Active. Software clears this bit by writing a one to this bit position.		
6	FPR		Force port resume	0	R/W
			Software sets this bit to one to drive resume signaling. The Host Controller sets this bit to one if a J-to-K transition is detected while the port is in the Suspended state. When this bit transitions to a one because a J-to-K transition is detected, the Port Change Detect bit in the USBSTS register is also set to one. This bit will automatically change to zero after the resume sequence is complete. This behavior is different from EHCI where the host controller driver is required to set this bit to a zero after the resume duration is timed in the driver.		
			Note that when the Host controller owns the port, the resume sequence follows the defined sequence documented in the USB Specification Revision 2.0. The resume signaling (Full-speed 'K') is driven on the port as long as this bit remains a one. This bit will remain a one until the port has switched to the high-speed idle. Writing a zero has no affect because the port controller will time the resume operation clear the bit the port control state switches to HS or FS idle.		
			This bit is 0 if PP (Port Power bit) is 0.		
		0	No resume (K-state) detected/driven on port.		
		1	Resume detected/driven on port.		

Table 473. Port Status and Control register in host mode (PORTSC1_H - address 0x4000 7184) bit description
...continued

Bit	Symbol	Value	Description	Reset value	Access
7	SUSP		Suspend Together with the PE (Port enabled bit), this bit describes the port states, see Table 474 "Port states as described by the PE and SUSP bits in the PORTSC1 register" . The host controller will unconditionally set this bit to zero when software sets the Force Port Resume bit to zero. The host controller ignores a write of zero to this bit. If host software sets this bit to a one when the port is not enabled (i.e. Port enabled bit is a zero) the results are undefined. This bit is 0 if PP (Port Power bit) is 0.	0	R/W
		0	Port not in Suspended state		
		1	Port in Suspended state When in Suspended state, downstream propagation of data is blocked on this port, except for port reset. The blocking occurs at the end of the current transaction if a transaction was in progress when this bit was written to 1. In the Suspended state, the port is sensitive to resume detection. Note that the bit status does not change until the port is suspended and that there may be a delay in suspending a port if there is a transaction currently in progress on the USB.		
8	PR		Port reset When software writes a one to this bit the bus-reset sequence as defined in the USB Specification Revision 2.0 is started. This bit will automatically change to zero after the reset sequence is complete. This behavior is different from EHCI where the host controller driver is required to set this bit to a zero after the reset duration is timed in the driver. This bit is 0 if PP (Port Power bit) is 0.	0	R/W
		0	Port is not in the reset state.		
		1	Port is in the reset state.		
9	HSP		High-speed status	0	RO
		0	Host/device connected to the port is not in High-speed mode.		
		1	Host/device connected to the port is in High-speed mode.		
11:10	LS		Line status These bits reflect the current logical levels of the USB_DP and USB_DM signal lines. USB_DP corresponds to bit 11 and USB_DM to bit 10. In host mode, the use of linestate by the host controller driver is not necessary for this controller (unlike EHCI) because the controller hardware manages the connection of LS and FS.	0x3	RO
0x0	SE0 (USB_DP and USB_DM LOW)				
0x1	J-state (USB_DP HIGH and USB_DM LOW)				
0x2	K-state (USB_DP LOW and USB_DM HIGH)				
0x3	Undefined				

Table 473. Port Status and Control register in host mode (PORTSC1_H - address 0x4000 7184) bit description
...continued

Bit	Symbol	Value	Description	Reset value	Access
12	PP	-	<p>Port power control</p> <p>Host controller requires port power control switches. This bit represents the current setting of the switch (0=off, 1=on). When power is not available on a port (i.e. PP equals a 0), the port is non-functional and will not report attaches, detaches, etc.</p> <p>When an over-current condition is detected on a powered port and PPC is a one, the PP bit in each affected port may be transitioned by the host controller driver from a one to a zero (removing power from the port).</p>	0	R/W
		0	Port power off.		
		1	Port power on.		
13	-	-	Reserved	0	-
15:14	PIC1_0		<p>Port indicator control</p> <p>Writing to this field controls the value of the pins USB1_IND1 and USB1_IND0.</p>	00	R/W
		0x0	Port indicators are off.		
		0x1	Amber		
		0x2	Green		
		0x3	Undefined		
19:16	PTC3_0		<p>Port test control</p> <p>Any value other than 0000 indicates that the port is operating in test mode.</p> <p>The FORCE_ENABLE_FS and FORCE_ENABLE_LS are extensions to the test mode support specified in the EHCI specification. Writing the PTC field to any of the FORCE_ENABLE_{HS/FS/LS} values will force the port into the connected and enabled state at the selected speed. Writing the PTC field back to TEST_MODE_DISABLE will allow the port state machines to progress normally from that point. Values 0x8 to 0xF are reserved.</p>	0000	R/W
		0x0	TEST_MODE_DISABLE		
		0x1	J_STATE		
		0x2	K_STATE		
		0x3	SE0 (host)/NAK (device)		
		0x4	Packet		
		0x5	FORCE_ENABLE_HS		
		0x6	FORCE_ENABLE_FS		
		0x7	FORCE_ENABLE_LS		
20	WKCN		<p>Wake on connect enable (WKCNTNT_E)</p> <p>This bit is 0 if PP (Port Power bit) is 0</p>	0	R/W
		0	Disables the port to wake up on device connects.		
		1	Writing this bit to a one enables the port to be sensitive to device connects as wake-up events.		

Table 473. Port Status and Control register in host mode (PORTSC1_H - address 0x4000 7184) bit description
...continued

Bit	Symbol	Value	Description	Reset value	Access
21	WKDC		Wake on disconnect enable (WKDSCNNT_E) This bit is 0 if PP (Port Power bit) is 0.	0	R/W
		0	Disables the port to wake up on device disconnects.		
		1	Writing this bit to a one enables the port to be sensitive to device disconnects as wake-up events.		
22	WKOC		Wake on over-current enable (WKOC_E)	0	R/W
		0	Disables the port to wake up on over-current events.		
		1	Writing a one to this bit enabled the port to be sensitive to over-current conditions as wake-up events.		
23	PHCD		PHY low power suspend - clock disable (PLPSCD) In host mode, the PHY can be put into Low Power Suspend – Clock Disable when the downstream device has been put into suspend mode or when no downstream device is connected. Low power suspend is completely under the control of software.	0	R/W
		0	Writing a 0 enables the PHY clock. Reading a 0 indicates the status of the PHY clock (enabled).		
		1	Writing a 1 disables the PHY clock. Reading a 1 indicates the status of the PHY clock (disabled).		
24	PFSC		Port force full speed connect	0	R/W
		0	Port connects at any speed.		
		1	Writing this bit to a 1 will force the port to only connect at Full Speed. It disables the chirp sequence that allows the port to identify itself as High Speed. This is useful for testing FS configurations with a HS host, hub or device.		
25	-	-	Reserved		
27:26	PSPD		Port speed This register field indicates the speed at which the port is operating. For HS mode operation in the host controller and HS/FS operation in the device controller the port routing steers data to the Protocol engine. For FS and LS mode operation in the host controller, the port routing steers data to the Protocol Engine w/ Embedded Transaction Translator.	0	RO
0x0	Full-speed				
0x1	Low-speed				
0x2	High-speed				
29:28	-	-	Reserved	-	-
31:30	PTS		Parallel transceiver select. All other values are reserved.	-	R/W
		0x2	ULPI		
		0x3	Serial/ 1.1 PHY (Full-speed only)		

Table 474. Port states as described by the PE and SUSP bits in the PORTSC1 register

PE bit	SUSP bit	Port state
0	0 or 1	disabled
1	0	enabled
1	1	suspend

24.6.16 USB Mode register (USBMODE)

The USBMODE register sets the USB mode for the USB controller. The possible modes are Device, Host, and Idle mode.

24.6.16.1 Device mode

Table 475. USB Mode register in device mode (USBMODE_D - address 0x4000 71A8) bit description

Bit	Symbol	Value	Description	Reset value	Access
1:0	CM1_0		Controller mode	00	R/ WO
		0x0	Idle		
		0x1	Reserved		
		0x2	Device controller		
		0x3	Host controller		
2	ES		Endian select	0	R/W
		0	Little endian: first byte referenced in least significant byte of 32-bit word.		
		1	Big endian: first byte referenced in most significant byte of 32-bit word.		
3	SLOM		Setup Lockout mode	0	R/W
		0	Setup Lockouts on		
		1	Setup Lockouts Off (DCD requires the use of Setup Buffer Tripwire in USBCMD)		

Table 475. USB Mode register in device mode (USBMODE_D - address 0x4000 71A8) bit description ...continued

Bit	Symbol	Value	Description	Reset value	Access
4	SDIS		Stream disable mode	0	R/W
		0	Enabled. Stream mode enabled.		
		1	Disabled. Stream mode disabled. Setting this bit to one disables double priming on both RX and TX for low bandwidth systems. This mode ensures that when the RX and TX buffers are sufficient to contain an entire packet that the standard double buffering scheme is disabled to prevent overruns/underruns in bandwidth limited systems. Note: In High Speed Mode, all packets received will be responded to with a NYET handshake when stream disable is active.		
5	-	-	Not used in device mode.	0	-
31:6	-	-	Reserved		

24.6.16.2 Host mode

Table 476. USB Mode register in host mode (USBMODE_H - address 0x4000 71A8) bit description

Bit	Symbol	Value	Description	Reset value	Access
1:0	CM1_0		Controller mode	00	R/ WO
		0x0	Idle		
		0x1	Reserved		
		0x2	Device controller		
		0x3	Host controller		
2	ES		Endian select	0	R/W
		0	Little endian: first byte referenced in least significant byte of 32-bit word.		
		1	Big endian: first byte referenced in most significant byte of 32-bit word.		
3	-	-	Not used in host mode	0	-

Table 476. USB Mode register in host mode (USBMODE_H - address 0x4000 71A8) bit description ...continued

Bit	Symbol	Value	Description	Reset value	Access
4	SDIS		Stream disable mode	0	R/W
		0	Enabled. Enable stream mode.		
		1	Disabled. Disable stream mode. Setting to a one ensures that overruns/underruns of the latency FIFO are eliminated for low bandwidth systems where the RX and TX buffers are sufficient to contain the entire packet. Disabling stream mode also has the effect of ensuring the TX latency is filled to capacity before the packet is launched onto the USB. Note: Time duration to pre-fill the FIFO becomes significant when stream disable is active. See TXFILLTUNING to characterize the adjustments needed for the scheduler when using this feature.		
5	VBPS		VBUS power select	0	R/WO
		0	vbus_pwr_select is set LOW.		
		1	vbus_pwr_select is set HIGH		
31:6	-	-	Reserved	-	-

24.6.17 USB Endpoint Setup Status register (ENDPSETUPSTAT)

Table 477. USB Endpoint Setup Status register (ENDPTSETUPSTAT - address 0x4000 71AC) bit description

Bit	Symbol	Description	Reset value	Access
3:0	ENDPT SETUP STAT	Setup endpoint status for logical endpoints. For every setup transaction that is received, a corresponding bit in this register is set to one. Software must clear or acknowledge the setup transfer by writing a one to a respective bit after it has read the setup data from Queue head. The response to a setup packet as in the order of operations and total response time is crucial to limit bus time outs while the setup lockout mechanism is engaged.	0	R/WC
31:4	-	Reserved	-	-

24.6.18 USB Endpoint Prime register (ENDPTPRIME)

For each endpoint, software should write a one to the corresponding bit whenever posting a new transfer descriptor to an endpoint. Hardware will automatically use this bit to begin parsing for a new transfer descriptor from the queue head and prepare a receive buffer. Hardware will clear this bit when the associated endpoint(s) is (are) successfully primed.

Remark: These bits will be momentarily set by hardware during hardware endpoint re-priming operations when a dTD is retired and the dQH is updated.

Table 478. USB Endpoint Prime register (ENDPTPRIME - address 0x4000 71B0) bit description

Bit	Symbol	Description	Reset value	Access
3:0	PERB	Prime endpoint receive buffer for physical OUT endpoints. For each OUT endpoint, a corresponding bit is set to 1 by software to request a buffer be prepared for a receive operation for when a USB host initiates a USB OUT transaction. Software should write a one to the corresponding bit whenever posting a new transfer descriptor to an endpoint. Hardware will automatically use this bit to begin parsing for a new transfer descriptor from the queue head and prepare a receive buffer. Hardware will clear this bit when the associated endpoint(s) is (are) successfully primed. PERB0 = endpoint 0 ... PERB3 = endpoint 3	0	R/WS
15:4	-	Reserved	-	-
19:16	PETB	Prime endpoint transmit buffer for physical IN endpoints. For each IN endpoint a corresponding bit is set to one by software to request a buffer be prepared for a transmit operation in order to respond to a USB IN/INTERRUPT transaction. Software should write a one to the corresponding bit when posting a new transfer descriptor to an endpoint. Hardware will automatically use this bit to begin parsing for a new transfer descriptor from the queue head and prepare a transmit buffer. Hardware will clear this bit when the associated endpoint(s) is (are) successfully primed. PETB0 = endpoint 0 ... PETB3 = endpoint 3	0	R/WS
31:20	-	Reserved	-	-

24.6.19 USB Endpoint Flush register (ENDPTFLUSH)

Writing a one to a bit(s) in this register will cause the associated endpoint(s) to clear any primed buffers. If a packet is in progress for one of the associated endpoints, then that transfer will continue until completion. Hardware will clear this register after the endpoint flush operation is successful.

Table 479. USB Endpoint Flush register (ENDPTFLUSH - address 0x4000 71B4) bit description

Bit	Symbol	Description	Reset value	Access
3:0	FERB	Flush endpoint receive buffer for physical OUT endpoints. Writing a one to a bit(s) will clear any primed buffers. FERB0 = endpoint 0 ... FERB3 = endpoint 3	0	R/WC

Table 479. USB Endpoint Flush register (ENDPTFLUSH - address 0x4000 71B4) bit description

Bit	Symbol	Description	Reset value	Access
15:4	-	Reserved	-	-
19:16	FETB	Flush endpoint transmit buffer for physical IN endpoints. Writing a one to a bit(s) will clear any primed buffers. FETB0 = endpoint 0 ... FETB3 = endpoint 3	0	R/WC
31:20	-	Reserved	-	-

24.6.20 USB Endpoint Status register (ENDPTSTAT)

One bit for each endpoint indicates status of the respective endpoint buffer. This bit is set by hardware as a response to receiving a command from a corresponding bit in the ENDPTPRIME register. There will always be a delay between setting a bit in the ENDPTPRIME register and endpoint indicating ready. This delay time varies based upon the current USB traffic and the number of bits set in the ENDPTPRIME register. Buffer ready is cleared by USB reset, by the USB DMA system, or through the ENDPTFLUSH register.

Remark: These bits will be momentarily cleared by hardware during hardware endpoint re-priming operations when a dTD is retired and the dQH is updated.

Table 480. USB Endpoint Status register (ENDPTSTAT - address 0x4000 71B8) bit description

Bit	Symbol	Description	Reset value	Access
3:0	ERBR	Endpoint receive buffer ready for physical OUT endpoints. This bit is set to 1 by hardware as a response to receiving a command from a corresponding bit in the ENDPTPRIME register. ERBR0 = endpoint 0 ... ERBR3 = endpoint 3	0	RO
15:4	-	Reserved	-	-
19:16	ETBR	Endpoint transmit buffer ready for physical IN endpoints 3 to 0. This bit is set to 1 by hardware as a response to receiving a command from a corresponding bit in the ENDPTPRIME register. ETBR0 = endpoint 0 ... ETBR3 = endpoint 3	0	RO
31:20	-	Reserved	-	-

24.6.21 USB Endpoint Complete register (ENDPTCOMPLETE)

Each bit in this register indicates that a received/transmit event occurred and software should read the corresponding endpoint queue to determine the transfer status. If the corresponding IOC bit is set in the Transfer Descriptor, then this bit will be set simultaneously with the USBINT.

Writing a one will clear the corresponding bit in this register.

Table 481. USB Endpoint Complete register (ENDPTCOMPLETE - address 0x4000 71BC) bit description

Bit	Symbol	Description	Reset value	Access
3:0	ERCE	Endpoint receive complete event for physical OUT endpoints. This bit is set to 1 by hardware when a receive event (OUT) occurred. ERCE0 = endpoint 0 ... ERCE3 = endpoint 3	0	R/WC
15:4	-	Reserved	-	-
19:16	ETCE	Endpoint transmit complete event for physical IN endpoints. This bit is set to 1 by hardware when a transmit event (IN/INTERRUPT) occurred. ETCE0 = endpoint 0 ... ETCE3 = endpoint 3	0	R/WC
31:20	-	Reserved	-	-

24.6.22 USB Endpoint 0 Control register (ENDPTCTRL0)

This register initializes endpoint 0 for control transfer. Endpoint 0 is always a control endpoint.

Table 482. USB Endpoint 0 Control register (ENDPTCTRL0 - address 0x4000 71C0) bit description

Bit	Symbol	Value	Description	Reset value	Access
0	RXS		Rx endpoint stall	0	R/W
		0	Endpoint ok.		
		1	Endpoint stalled Software can write a one to this bit to force the endpoint to return a STALL handshake to the Host. It will continue returning STALL until the bit is cleared by software, or it will automatically be cleared upon receipt of a new SETUP request. After receiving a SETUP request, this bit will continue to be cleared by hardware until the associated ENDSETUPSTAT bit is cleared. [1]		
1	-	-	Reserved	-	-
3:2	RXT	0x0	Endpoint type Endpoint 0 is always a control endpoint.	0	R/W
6:4	-	-	Reserved	-	-
7	RXE	1	Rx endpoint enable Endpoint enabled. Control endpoint 0 is always enabled. This bit is always 1.	1	RO
15:8	-	-	Reserved	-	-

Table 482. USB Endpoint 0 Control register (ENDPTCTRL0 - address 0x4000 71C0) bit description ...continued

Bit	Symbol	Value	Description	Reset value	Access
16	TXS		Tx endpoint stall		R/W
		0	Endpoint ok.		
		1	Endpoint stalled Software can write a one to this bit to force the endpoint to return a STALL handshake to the Host. It will continue returning STALL until the bit is cleared by software, or it will automatically be cleared upon receipt of a new SETUP request. After receiving a SETUP request, this bit will continue to be cleared by hardware until the associated ENDSETUPSTAT bit is cleared. ^[1]		
17	-	-	Reserved		
19:18	TXT	0x0	Endpoint type Endpoint 0 is always a control endpoint.	0	RO
22:20	-	-	Reserved		
23	TXE	1	Tx endpoint enable Endpoint enabled. Control endpoint 0 is always enabled. This bit is always 1.	1	RO
31:24	-	-	Reserved		

[1] There is a slight delay (50 clocks max) between the ENPTSETUPSTAT being cleared and hardware continuing to clear this bit. In most systems it is unlikely that the DCD software will observe this delay. However, should the DCD notice that the stall bit is not set after writing a one to it, software should continually write this stall bit until it is set or until a new setup has been received by checking the associated ENDPTSETUPSTAT bit.

24.6.23 Endpoint 1 to 3 control registers

Each endpoint that is not a control endpoint has its own register to set the endpoint type and enable or disable the endpoint.

Remark: The reset value for all endpoint types is the control endpoint. If one endpoint direction is enabled and the paired endpoint of opposite direction is disabled, then the endpoint type of the unused direction must be changed from the control type to any other type (e.g. bulk). Leaving an unconfigured endpoint control will cause undefined behavior for the data PID tracking on the active endpoint.

Table 483. USB Endpoint 1 to 3 control registers (ENDPTCTRL - address 0x4000 71C4 (ENDPTCTRL1) to 0x4000 71CC (ENDPTCTRL3)) bit description

Bit	Symbol	Value	Description	Reset value	Access	
0	RXS		Rx endpoint stall	0	R/W	
		0	Endpoint ok. This bit will be cleared automatically upon receipt of a SETUP request if this Endpoint is configured as a Control Endpoint and this bit will continue to be cleared by hardware until the associated ENDPTSETUPSTAT bit is cleared.			
		1	Endpoint stalled Software can write a one to this bit to force the endpoint to return a STALL handshake to the Host. It will continue returning STALL until the bit is cleared by software, or it will automatically be cleared upon receipt of a new SETUP request. ^[1]			

Table 483. USB Endpoint 1 to 3 control registers (ENDPTCTRL - address 0x4000 71C4 (ENDPTCTRL1) to 0x4000 71CC (ENDPTCTRL3)) bit description ...continued

Bit	Symbol	Value	Description	Reset value	Access
1	-		Reserved	0	R/W
3:2	RXT		Endpoint type	00	R/W
		0x0	Control		
		0x1	Isochronous		
		0x2	Bulk		
		0x3	Interrupt		
4	-	-	Reserved		
5	RXI		Rx data toggle inhibit	0	R/W
			This bit is only used for test and should always be written as zero. Writing a one to this bit will cause this endpoint to ignore the data toggle sequence and always accept data packets regardless of their data PID.		
		0	Disabled		
		1	Enabled		
6	RXR		Rx data toggle reset	0	WS
			Write 1 to reset the PID sequence.		
			Whenever a configuration event is received for this Endpoint, software must write a one to this bit in order to synchronize the data PIDs between the host and device.		
7	RXE		Rx endpoint enable	0	R/W
			Remark: An endpoint should be enabled only after it has been configured.		
		0	Endpoint disabled.		
		1	Endpoint enabled.		
15:8	-	-	Reserved		
16	TXS		Tx endpoint stall	0	R/W
		0	Endpoint ok.		
			This bit will be cleared automatically upon receipt of a SETUP request if this Endpoint is configured as a Control Endpoint, and this bit will continue to be cleared by hardware until the associated ENDPTSETUPSTAT bit is cleared.		
		1	Endpoint stalled		
			Software can write a one to this bit to force the endpoint to return a STALL handshake to the Host. It will continue returning STALL until the bit is cleared by software, or it will automatically be cleared upon receipt of a new SETUP request. [1]		
17	-	-	Reserved	0	-
19:18	TXT		Tx endpoint type	00	R/W
		0x0	Control		
		0x1	Isochronous		
		0x2	Bulk		
		0x3	Interrupt		
20	-	-	Reserved		

Table 483. USB Endpoint 1 to 3 control registers (ENDPTCTRL - address 0x4000 71C4 (ENDPTCTRL1) to 0x4000 71CC (ENDPTCTRL3)) bit description ...continued

Bit	Symbol	Value	Description	Reset value	Access
21	TXI		Tx data toggle inhibit This bit is only used for test and should always be written as zero. Writing a one to this bit will cause this endpoint to ignore the data toggle sequence and always accept data packets regardless of their data PID.	0	R/W
		0	Enabled		
		1	Disabled		
22	TXR		Tx data toggle reset Write 1 to reset the PID sequence. Whenever a configuration event is received for this Endpoint, software must write a one to this bit in order to synchronize the data PID's between the host and device.	1	WS
23	TXE		Tx endpoint enable Remark: An endpoint should be enabled only after it has been configured	0	R/W
		0	Endpoint disabled.		
		1	Endpoint enabled.		
31:24	-	-	Reserved	0	

[1] For control endpoints only: There is a slight delay (50 clocks max) between the ENPTSETUPSTAT being cleared and hardware continuing to clear this bit. In most systems it is unlikely that the DCD software will observe this delay. However, should the DCD notice that the stall bit is not set after writing a one to it, software should continually write this stall bit until it is set or until a new setup has been received by checking the associated ENDPTSETUPSTAT bit.

24.7 Functional description

For details on the device data structures, see [Section 23.9](#). For the device operational model, see [Section 23.10](#).

24.7.1 Susp_CTRL module for USB1

For a description of host and device power states, see [Section 23.12.1](#).

The SUSP_CTRL module implements the power management logic of USB block. It controls the suspend input of the transceiver. Asserting this suspend signal (PORTSC1.PHCD bit) will put the transceiver in suspend mode and the 60 MHz clock will be switched off.

In suspend mode, the transceiver will raise an output signal. For USB1, this signal is not connected to any register.

The SUSP_CTRL module also generates an output signal indicating whether the AHB clock is needed or not. If not, the AHB clock is allowed to be switched off or reduced in frequency in order to save power.

For USB1, this signal is connected to event #10 (USB1_L) in the event router (see [Table 74](#)). Software should check for this signal to be LOW before stopping the USB1 clock and putting the chip in low power mode. Note that the event router block doesn't

have a raw pin status register hence LOW level detection should be configured for this pin to detect when to turn the PLL off. Similarly, to detect resume signaling to leave low power state, software should configure this pin to detect a HIGH level in the event router.

The core will enter the low power state if:

- Software sets the PORTSC1.PHCD bit.

When operating in host mode, the core will leave the low power state on one of the following conditions:

- software clears the PORTSC1.PHCD bit
- a device is connected and the PORTSC1.WKCN bit is set
- a device is disconnected and the PORTSC1.WKDC bit is set
- an over-current condition occurs and the PORTSC1.WKOC bit is set
- a remote wake-up from the attached device occurs (when USB bus was in suspend)
- a change on vbusvalid occurs (= VBUS threshold at 4.4 V is crossed)
- a change on bvalid occurs (=VBUS threshold at 4.0 V is crossed).

When operating in device mode, the core will leave the low power state on one of the following conditions:

- software clears the PORTSC1.PHCD bit.
- a change on the USB data lines (dp/dm) occurs.
- a change on vbusvalid occurs (= VBUS threshold at 4.4 V is crossed).
- a change on bvalid occurs (= VBUS threshold at 4.0 V is crossed).

The vbusvalid and bvalid signals coming from the transceiver are not filtered in the SUSP_CTRL module. Any change on those signals will cause a wake-up event.

25.1 How to read this chapter

The USB ROM API is available on parts LPC185x/3x/2x.

25.2 Introduction

The boot ROM contains a USB driver to simplify the USB application development. The USB driver implements the Communication Device Class (CDC), the Human Interface Device (HID), and the Mass Storage Device (MSC) device class. The USB on-chip drivers support composite device.

25.3 USB driver functions

The USB device driver ROM API consists of the following modules:

- Communication Device Class (CDC) function driver. This module contains an internal implementation of the USB CDC Class. User applications can use this class driver instead of implementing the CDC-ACM class manually via the low-level USBD_HW and USBD_Core APIs. This module is designed to simplify the user code by exposing only the required interface needed to interface with Devices using the USB CDC-ACM Class.
 - Communication Device Class function driver initialization parameter data structure ([Table 511 “USBD_CDC_INIT_PARAM class structure”](#)).
 - CDC class API functions structure. This module exposes functions which interact directly with USB device controller hardware ([Table 510 “USBD_CDC_API class structure”](#)).
- USB core layer
 - struct ([Table 507 “WB_T class structure”](#))
 - union ([Table 484 “WORD_BYTE class structure”](#))
 - struct ([Table 485 “BM_T class structure”](#))
 - struct ([Table 498 “REQUEST_TYPE class structure”](#))
 - struct ([Table 505 “USB_SETUP_PACKET class structure”](#))
 - struct ([Table 501 “USB_DEVICE_QUALIFIER_DESCRIPTOR class structure”](#))
 - struct USB device descriptor
 - struct ([Table 501 “USB_DEVICE_QUALIFIER_DESCRIPTOR class structure”](#))
 - struct USB configuration descriptor
 - struct ([Table 503 “USB_INTERFACE_DESCRIPTOR class structure”](#))
 - struct USB endpoint descriptor
 - struct ([Table 506 “USB_STRING_DESCRIPTOR class structure”](#))
 - struct ([Table 499 “USB_COMMON_DESCRIPTOR class structure”](#))
 - struct ([Table 504 “USB_OTHER_SPEED_CONFIGURATION class structure”](#))

- USB descriptors data structure ([Table 500 “USB_CORE_DESCS_T class structure”](#))
- USB device stack initialization parameter data structure ([Table 509 “USBD_API_INIT_PARAM class structure”](#)).
- USB device stack core API functions structure ([Table 512 “USBD_CORE_API class structure”](#)).
- Device Firmware Upgrade (DFU) class function driver
 - DFU descriptors data structure ([Table 514 “USBD_DFU_INIT_PARAM class structure”](#)).
 - DFU class API functions structure. This module exposes functions which interact directly with the USB device controller hardware ([Table 513 “USBD_DFU_API class structure”](#)).
- HID class function driver
 - struct ([Table 493 “HID_DESCRIPTOR class structure”](#)).
 - struct ([Table 495 “HID_REPORT_T class structure”](#)).
 - USB descriptors data structure ([Table 516 “USBD_HID_INIT_PARAM class structure”](#)).
 - HID class API functions structure. This structure contains pointers to all the functions exposed by the HID function driver module ([Table 517 “USBD_HW_API class structure”](#)).
- USB device controller driver
 - Hardware API functions structure. This module exposes functions which interact directly with the USB device controller hardware ([Table 517 “USBD_HW_API class structure”](#)).
- Mass Storage Class (MSC) function driver
 - Mass Storage Class function driver initialization parameter data structure ([Table 519](#)).
 - MSC class API functions structure. This module exposes functions which interact directly with the USB device controller hardware ([Table 518](#)).

25.4 Calling the USB device driver

A fixed location in ROM contains a pointer to the ROM driver table i.e. 0x1FFF 1FF8. The ROM driver table contains a pointer to the USB driver table. Pointers to the various USB driver functions are stored in this table. USB driver functions can be called by using a C structure. [Figure 65](#) illustrates the pointer mechanism used to access the on-chip USB driver.

```
typedef struct USBD_API
{
    const USBD_HW_API_T* hw;

    const USBD_CORE_API_T* core;

    const USBD_MSC_API_T* msc;
```

```

const USBD_DFU_API_T* dfu;

const USBD_HID_API_T* hid;

const USBD_CDC_API_T* cdc;

const uint32_t* reserved6;

const uint32_t version;

} USBD_API_T;
    
```

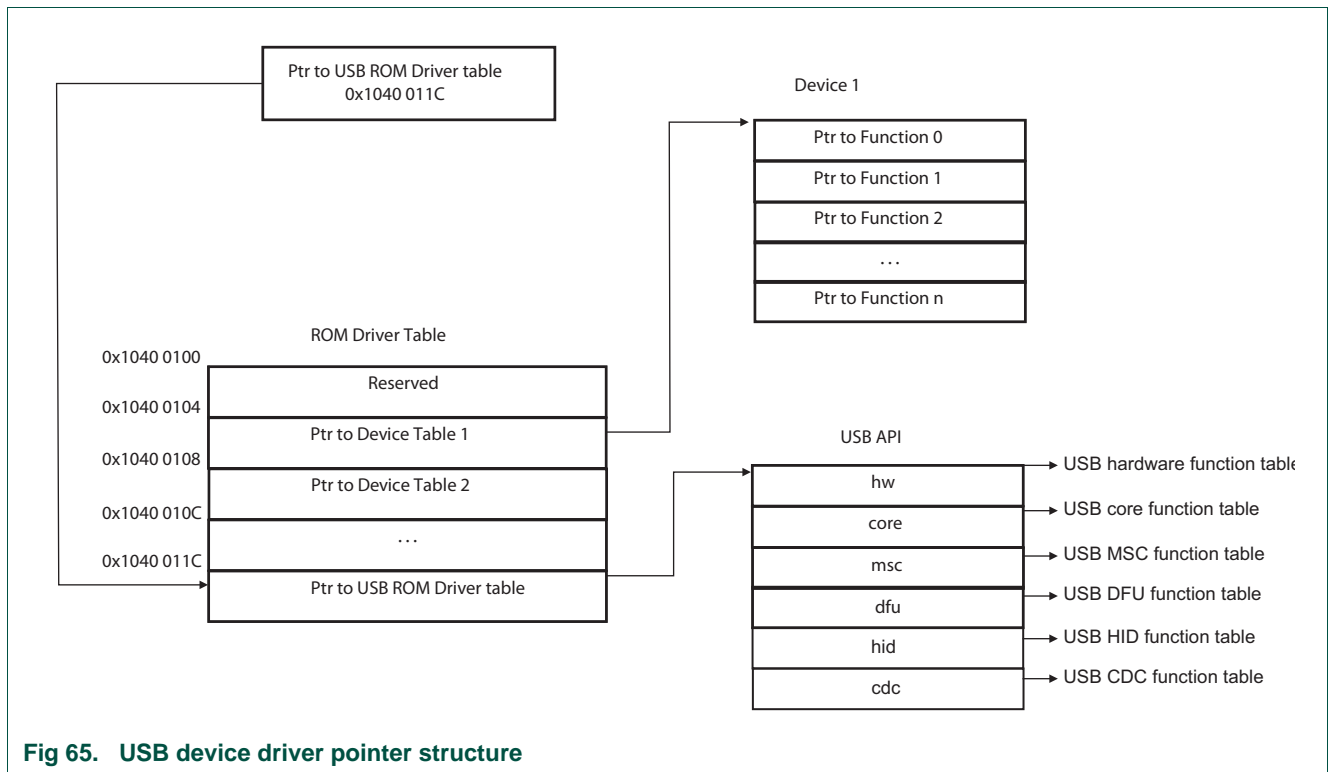

Fig 65. USB device driver pointer structure

25.5 USB API

25.5.1 __WORD_BYTE

Table 484. __WORD_BYTE class structure

Member	Description
W	uint16_t __WORD_BYTE::W data member to do 16 bit access
WB	WB_TWBT __WORD_BYTE::WB data member to do 8 bit access

25.5.2 _BM_T

Table 485. `_BM_T` class structure

Member	Description
Recipient	<code>uint8_t_BM_T::Recipient</code> Recipient type.
Type	<code>uint8_t_BM_T::Type</code> Request type.
Dir	<code>uint8_t_BM_T::Dir</code> Direction type.

25.5.3 `_CDC_ABSTRACT_CONTROL_MANAGEMENT_DESCRIPTOR`

Table 486. `_CDC_ABSTRACT_CONTROL_MANAGEMENT_DESCRIPTOR` class structure

Member	Description
<code>bFunctionLength</code>	<code>uint8_t_CDC_ABSTRACT_CONTROL_MANAGEMENT_DESCRIPTOR::bFunctionLength</code>
<code>bDescriptorType</code>	<code>uint8_t_CDC_ABSTRACT_CONTROL_MANAGEMENT_DESCRIPTOR::bDescriptorType</code>
<code>bDescriptorSubtype</code>	<code>uint8_t_CDC_ABSTRACT_CONTROL_MANAGEMENT_DESCRIPTOR::bDescriptorSubtype</code>
<code>bmCapabilities</code>	<code>uint8_t_CDC_ABSTRACT_CONTROL_MANAGEMENT_DESCRIPTOR::bmCapabilities</code>

25.5.4 `_CDC_CALL_MANAGEMENT_DESCRIPTOR`

Table 487. `_CDC_CALL_MANAGEMENT_DESCRIPTOR` class structure

Member	Description
<code>bFunctionLength</code>	<code>uint8_t_CDC_CALL_MANAGEMENT_DESCRIPTOR::bFunctionLength</code>
<code>bDescriptorType</code>	<code>uint8_t_CDC_CALL_MANAGEMENT_DESCRIPTOR::bDescriptorType</code>
<code>bDescriptorSubtype</code>	<code>uint8_t_CDC_CALL_MANAGEMENT_DESCRIPTOR::bDescriptorSubtype</code>
<code>bmCapabilities</code>	<code>uint8_t_CDC_CALL_MANAGEMENT_DESCRIPTOR::bmCapabilities</code>
<code>bDataInterface</code>	<code>uint8_t_CDC_CALL_MANAGEMENT_DESCRIPTOR::bDataInterface</code>

25.5.5 `_CDC_HEADER_DESCRIPTOR`

Table 488. `_CDC_HEADER_DESCRIPTOR` class structure

Member	Description
<code>bFunctionLength</code>	<code>uint8_t_CDC_HEADER_DESCRIPTOR::bFunctionLength</code>
<code>bDescriptorType</code>	<code>uint8_t_CDC_HEADER_DESCRIPTOR::bDescriptorType</code>
<code>bDescriptorSubtype</code>	<code>uint8_t_CDC_HEADER_DESCRIPTOR::bDescriptorSubtype</code>
<code>bcdCDC</code>	<code>uint16_t_CDC_HEADER_DESCRIPTOR::bcdCDC</code>

25.5.6 `_CDC_LINE_CODING`

Table 489. `_CDC_LINE_CODING` class structure

Member	Description
<code>dwDTERate</code>	<code>uint32_t _CDC_LINE_CODING::dwDTERate</code>
<code>bCharFormat</code>	<code>uint8_t _CDC_LINE_CODING::bCharFormat</code>
<code>bParityType</code>	<code>uint8_t _CDC_LINE_CODING::bParityType</code>
<code>bDataBits</code>	<code>uint8_t _CDC_LINE_CODING::bDataBits</code>

25.5.7 `_CDC_UNION_1SLAVE_DESCRIPTOR`

Table 490. `_CDC_UNION_1SLAVE_DESCRIPTOR` class structure

Member	Description
<code>sUnion</code>	<code>CDC_UNION_DESCRIPTOR CDC_UNION_DESCRIPTOR _CDC_UNION_1SLAVE_DESCRIPTOR::sUnion</code>
<code>bSlaveInterfaces</code>	<code>uint8_t _CDC_UNION_1SLAVE_DESCRIPTOR::bSlaveInterfaces[1][1]</code>

25.5.8 `_CDC_UNION_DESCRIPTOR`

Table 491. `_CDC_UNION_DESCRIPTOR` class structure

Member	Description
<code>bFunctionLength</code>	<code>uint8_t _CDC_UNION_DESCRIPTOR::bFunctionLength</code>
<code>bDescriptorType</code>	<code>uint8_t _CDC_UNION_DESCRIPTOR::bDescriptorType</code>
<code>bDescriptorSubtype</code>	<code>uint8_t _CDC_UNION_DESCRIPTOR::bDescriptorSubtype</code>
<code>bMasterInterface</code>	<code>uint8_t _CDC_UNION_DESCRIPTOR::bMasterInterface</code>

25.5.9 `_DFU_STATUS`

Table 492. `_DFU_STATUS` class structure

Member	Description
<code>bStatus</code>	<code>uint8_t _DFU_STATUS::bStatus</code>
<code>bwPollTimeout</code>	<code>uint8_t _DFU_STATUS::bwPollTimeout[3][3]</code>
<code>bState</code>	<code>uint8_t _DFU_STATUS::bState</code>
<code>iString</code>	<code>uint8_t _DFU_STATUS::iString</code>

25.5.10 `_HID_DESCRIPTOR`

HID class-specific HID Descriptor.

Table 493. _HID_DESCRIPTOR class structure

Member	Description
bLength	uint8_t _HID_DESCRIPTOR::bLength Size of the descriptor, in bytes.
bDescriptorType	uint8_t _HID_DESCRIPTOR::bDescriptorType Type of HID descriptor.
bcdHID	uint16_t _HID_DESCRIPTOR::bcdHID BCD encoded version that the HID descriptor and device complies to.
bCountryCode	uint8_t _HID_DESCRIPTOR::bCountryCode Country code of the localized device, or zero if universal.
bNumDescriptors	uint8_t _HID_DESCRIPTOR::bNumDescriptors Total number of HID report descriptors for the interface.
DescriptorList	PRE_PACK struct POST_PACK _HID_DESCRIPTOR::_HID_DESCRIPTOR_LIST PRE_PACK struct POST_PACK _HID_DESCRIPTOR::_HID_DESCRIPTOR_LIST _HID_DESCRIPTOR::DescriptorList[1][1] Array of one or more descriptors

25.5.11 _HID_DESCRIPTOR::_HID_DESCRIPTOR_LIST

Table 494. _HID_DESCRIPTOR::_HID_DESCRIPTOR_LIST class structure

Member	Description
bDescriptorType	uint8_t _HID_DESCRIPTOR::_HID_DESCRIPTOR_LIST::bDescriptorType Type of HID report.
wDescriptorLength	uint16_t _HID_DESCRIPTOR::_HID_DESCRIPTOR_LIST::wDescriptorLength Length of the associated HID report descriptor, in bytes.

25.5.12 _HID_REPORT_T

HID report descriptor data structure.

Table 495. _HID_REPORT_T class structure

Member	Description
len	uint16_t _HID_REPORT_T::len Size of the report descriptor in bytes.
idle_time	uint8_t _HID_REPORT_T::idle_time This value is used by stack to respond to Set_Idle & GET_Idle requests for the specified report ID. The value of this field specified the rate at which duplicate reports are generated for the specified Report ID. For example, a device with two input reports could specify an idle rate of 20 milliseconds for report ID 1 and 500 milliseconds for report ID 2.
__pad	uint8_t _HID_REPORT_T::__pad Padding space.
desc	uint8_t * _HID_REPORT_T::desc Report descriptor.

25.5.13 _MSC_CBW

Table 496. `_MSC_CBW` class structure

Member	Description
dSignature	uint32_t _MSC_CBW::dSignature
dTag	uint32_t _MSC_CBW::dTag
dDataLength	uint32_t _MSC_CBW::dDataLength
bmFlags	uint8_t _MSC_CBW::bmFlags
bLUN	uint8_t _MSC_CBW::bLUN
bCBLength	uint8_t _MSC_CBW::bCBLength
CB	uint8_t _MSC_CBW::CB[16][16]

25.5.14 `_MSC_CSW`

Table 497. `_MSC_CSW` class structure

Member	Description
dSignature	uint32_t _MSC_CSW::dSignature
dTag	uint32_t _MSC_CSW::dTag
dDataResidue	uint32_t _MSC_CSW::dDataResidue
bStatus	uint8_t _MSC_CSW::bStatus

25.5.15 `_REQUEST_TYPE`

Table 498. `_REQUEST_TYPE` class structure

Member	Description
B	uint8_t _REQUEST_TYPE::B byte wide access member
BM	BM_TBM_T _REQUEST_TYPE::BM bitfield structure access member

25.5.16 `_USB_COMMON_DESCRIPTOR`

Table 499. `_USB_COMMON_DESCRIPTOR` class structure

Member	Description
bLength	uint8_t _USB_COMMON_DESCRIPTOR::bLength Size of this descriptor in bytes
bDescriptorType	uint8_t _USB_COMMON_DESCRIPTOR::bDescriptorType Descriptor Type

25.5.17 `_USB_CORE_DESCS_T`

USB descriptors data structure.

Table 500. _USB_CORE_DESCS_T class structure

Member	Description
device_desc	uint8_t * _USB_CORE_DESCS_T::device_desc Pointer to USB device descriptor
string_desc	uint8_t * _USB_CORE_DESCS_T::string_desc Pointer to array of USB string descriptors
full_speed_desc	uint8_t * _USB_CORE_DESCS_T::full_speed_desc Pointer to USB device configuration descriptor when device is operating in full speed mode.
high_speed_desc	uint8_t * _USB_CORE_DESCS_T::high_speed_desc Pointer to USB device configuration descriptor when device is operating in high speed mode. For full-speed only implementation this pointer should be same as full_speed_desc.
device_qualifier	uint8_t * _USB_CORE_DESCS_T::device_qualifier Pointer to USB device qualifier descriptor. For full-speed only implementation this pointer should be set to null (0).

25.5.18 _USB_DEVICE_QUALIFIER_DESCRIPTOR

Table 501. _USB_DEVICE_QUALIFIER_DESCRIPTOR class structure

Member	Description
bLength	uint8_t _USB_DEVICE_QUALIFIER_DESCRIPTOR::bLength Size of descriptor
bDescriptorType	uint8_t _USB_DEVICE_QUALIFIER_DESCRIPTOR::bDescriptorType Device Qualifier Type
bcdUSB	uint16_t _USB_DEVICE_QUALIFIER_DESCRIPTOR::bcdUSB USB specification version number (e.g., 0200H for V2.00)
bDeviceClass	uint8_t _USB_DEVICE_QUALIFIER_DESCRIPTOR::bDeviceClass Class Code
bDeviceSubClass	uint8_t _USB_DEVICE_QUALIFIER_DESCRIPTOR::bDeviceSubClass SubClass Code
bDeviceProtocol	uint8_t _USB_DEVICE_QUALIFIER_DESCRIPTOR::bDeviceProtocol Protocol Code
bMaxPacketSize0	uint8_t _USB_DEVICE_QUALIFIER_DESCRIPTOR::bMaxPacketSize0 Maximum packet size for other speed
bNumConfigurations	uint8_t _USB_DEVICE_QUALIFIER_DESCRIPTOR::bNumConfigurations Number of Other-speed Configurations
bReserved	uint8_t _USB_DEVICE_QUALIFIER_DESCRIPTOR::bReserved Reserved for future use, must be zero

25.5.19 _USB_DFU_FUNC_DESCRIPTOR

Table 502. _USB_DFU_FUNC_DESCRIPTOR class structure

Member	Description
bLength	uint8_t _USB_DFU_FUNC_DESCRIPTOR::bLength
bDescriptorType	uint8_t _USB_DFU_FUNC_DESCRIPTOR::bDescriptorType
bmAttributes	uint8_t _USB_DFU_FUNC_DESCRIPTOR::bmAttributes
wDetachTimeOut	uint16_t _USB_DFU_FUNC_DESCRIPTOR::wDetachTimeOut
wTransferSize	uint16_t _USB_DFU_FUNC_DESCRIPTOR::wTransferSize
bcdDFUVersion	uint16_t _USB_DFU_FUNC_DESCRIPTOR::bcdDFUVersion

25.5.20 _USB_INTERFACE_DESCRIPTOR

Table 503. _USB_INTERFACE_DESCRIPTOR class structure

Member	Description
bLength	uint8_t _USB_INTERFACE_DESCRIPTOR::bLength Size of this descriptor in bytes
bDescriptorType	uint8_t _USB_INTERFACE_DESCRIPTOR::bDescriptorType INTERFACE Descriptor Type
bInterfaceNumber	uint8_t _USB_INTERFACE_DESCRIPTOR::bInterfaceNumber Number of this interface. Zero-based value identifying the index in the array of concurrent interfaces supported by this configuration.
bAlternateSetting	uint8_t _USB_INTERFACE_DESCRIPTOR::bAlternateSetting Value used to select this alternate setting for the interface identified in the prior field
bNumEndpoints	uint8_t _USB_INTERFACE_DESCRIPTOR::bNumEndpoints Number of endpoints used by this interface (excluding endpoint zero). If this value is zero, this interface only uses the Default Control Pipe.
bInterfaceClass	uint8_t _USB_INTERFACE_DESCRIPTOR::bInterfaceClass Class code (assigned by the USB-IF).
bInterfaceSubClass	uint8_t _USB_INTERFACE_DESCRIPTOR::bInterfaceSubClass Subclass code (assigned by the USB-IF).
bInterfaceProtocol	uint8_t _USB_INTERFACE_DESCRIPTOR::bInterfaceProtocol Protocol code (assigned by the USB).
iInterface	uint8_t _USB_INTERFACE_DESCRIPTOR::iInterface Index of string descriptor describing this interface

25.5.21 _USB_OTHER_SPEED_CONFIGURATION

Table 504. `_USB_OTHER_SPEED_CONFIGURATION` class structure

Member	Description
bLength	uint8_t_USB_OTHER_SPEED_CONFIGURATION::bLength Size of descriptor
bDescriptorType	uint8_t_USB_OTHER_SPEED_CONFIGURATION::bDescriptorType Other_speed_Configuration Type
wTotalLength	uint16_t_USB_OTHER_SPEED_CONFIGURATION::wTotalLength Total length of data returned
bNumInterfaces	uint8_t_USB_OTHER_SPEED_CONFIGURATION::bNumInterfaces Number of interfaces supported by this speed configuration
bConfigurationValue	uint8_t_USB_OTHER_SPEED_CONFIGURATION::bConfigurationValue Value to use to select configuration
IConfiguration	uint8_t_USB_OTHER_SPEED_CONFIGURATION::IConfiguration Index of string descriptor
bmAttributes	uint8_t_USB_OTHER_SPEED_CONFIGURATION::bmAttributes Same as Configuration descriptor
bMaxPower	uint8_t_USB_OTHER_SPEED_CONFIGURATION::bMaxPower Same as Configuration descriptor

25.5.22 `_USB_SETUP_PACKET`

Table 505. `_USB_SETUP_PACKET` class structure

Member	Description
bmRequestType	REQUEST_TYPE_USB_SETUP_PACKET::bmRequestType This bit-mapped field identifies the characteristics of the specific request. _BM_T.
bRequest	uint8_t_USB_SETUP_PACKET::bRequest This field specifies the particular request. The Type bits in the bmRequestType field modify the meaning of this field. USBD_REQUEST.
wValue	WORD_BYTE_USB_SETUP_PACKET::wValue Used to pass a parameter to the device, specific to the request.
wIndex	WORD_BYTE_USB_SETUP_PACKET::wIndex Used to pass a parameter to the device, specific to the request. The wIndex field is often used in requests to specify an endpoint or an interface.
wLength	uint16_t_USB_SETUP_PACKET::wLength This field specifies the length of the data transferred during the second phase of the control transfer.

25.5.23 `_USB_STRING_DESCRIPTOR`

Table 506. _USB_STRING_DESCRIPTOR class structure

Member	Description
bLength	uint8_t _USB_STRING_DESCRIPTOR::bLength Size of this descriptor in bytes
bDescriptorType	uint8_t _USB_STRING_DESCRIPTOR::bDescriptorType STRING Descriptor Type
bString	uint16_t _USB_STRING_DESCRIPTOR::bString UNICODE encoded string

25.5.24 _WB_T

Table 507. _WB_T class structure

Member	Description
L	uint8_t _WB_T::L lower byte
H	uint8_t _WB_T::H upper byte

25.5.25 USBD_API

Main USBD API functions structure. This structure contains pointer to various USB Device stack's sub-module function tables. This structure is used as main entry point to access various methods (grouped in sub-modules) exposed by ROM based USB device stack.

Table 508. USBD_API class structure

Member	Description
hw	const USBD_HW_API_T* USBD_API::hw Pointer to function table which exposes functions which interact directly with USB device stack's core layer.
core	const USBD_CORE_API_T* USBD_API::core Pointer to function table which exposes functions which interact directly with USB device controller hardware.
msc	const USBD_MSC_API_T* USBD_API::msc Pointer to function table which exposes functions provided by MSC function driver module.
dfu	const USBD_DFU_API_T* USBD_API::dfu Pointer to function table which exposes functions provided by DFU function driver module.
hid	const USBD_HID_API_T* USBD_API::hid Pointer to function table which exposes functions provided by HID function driver module.

Table 508. USBD_API class structure

Member	Description
cdc	const USBD_CDC_API_T* USBD_API::cdc Pointer to function table which exposes functions provided by CDC-ACM function driver module.
reserved6	const uint32_t* USBD_API::reserved6 Reserved for future function driver module.
version	const uint32_t USBD_API::version Version identifier of USB ROM stack. The version is defined as 0x0CHDMhCC where each nibble represents version number of the corresponding component. CC - 7:0 - 8bit core version number h - 11:8 - 4bit hardware interface version number M - 15:12 - 4bit MSC class module version number D - 19:16 - 4bit DFU class module version number H - 23:20 - 4bit HID class module version number C - 27:24 - 4bit CDC class module version number H - 31:28 - 4bit reserved

25.5.26 USBD_API_INIT_PARAM

USB device stack initialization parameter data structure.

Table 509. USBD_API_INIT_PARAM class structure

Member	Description
usb_reg_base	uint32_t USBD_API_INIT_PARAM::usb_reg_base USB device controller's base register address.
mem_base	uint32_t USBD_API_INIT_PARAM::mem_base Base memory location from where the stack can allocate data and buffers. Remark: The memory address set in this field should be accessible by USB DMA controller. Also this value should be aligned on 2048 byte boundary.
mem_size	uint32_t USBD_API_INIT_PARAM::mem_size The size of memory buffer which stack can use. Remark: The mem_size should be greater than the size returned by USBD_HW_API::GetMemSize() routine.
max_num_ep	uint8_t USBD_API_INIT_PARAM::max_num_ep max number of endpoints supported by the USB device controller instance (specified by
pad0	uint8_t USBD_API_INIT_PARAM::pad0[3][3]
USB_Reset_Event	USB_CB_T USBD_API_INIT_PARAM::USB_Reset_Event Event for USB interface reset. This event fires when the USB host requests that the device reset its interface. This event fires after the control endpoint has been automatically configured by the library. Remark: This event is called from USB_ISR context and hence is time-critical. Having delays in this callback will prevent the device from enumerating correctly or operate properly.
USB_Suspend_Event	USB_CB_T USBD_API_INIT_PARAM::USB_Suspend_Event Event for USB suspend. This event fires when the USB host suspends the device by halting its transmission of Start Of Frame pulses to the device. This is generally hooked in order to move the device over to a low power state until the host wakes up the device. Remark: This event is called from USB_ISR context and hence is time-critical. Having delays in this callback will cause other system issues.

Table 509. USBD_API_INIT_PARAM class structure

Member	Description
USB_Resume_Event	<p>USB_CB_T USBD_API_INIT_PARAM::USB_Resume_Event</p> <p>Event for USB wake up or resume. This event fires when a the USB device interface is suspended and the host wakes up the device by supplying Start Of Frame pulses. This is generally hooked to pull the user application out of a low power state and back into normal operating mode.</p> <p>Remark: This event is called from USB_ISR context and hence is time-critical. Having delays in this callback will cause other system issues.</p>
reserved_sbz	<p>USB_CB_T USBD_API_INIT_PARAM::reserved_sbz</p> <p>Reserved parameter should be set to zero.</p>
USB_SOF_Event	<p>USB_CB_T USBD_API_INIT_PARAM::USB_SOF_Event</p> <p>Event for USB Start Of Frame detection, when enabled. This event fires at the start of each USB frame, once per millisecond in full-speed mode or once per 125 microseconds in high-speed mode, and is synchronized to the USB bus.</p> <p>This event is time-critical; it is run once per millisecond (full-speed mode) and thus long handlers will significantly degrade device performance. This event should only be enabled when needed to reduce device wake-ups.</p> <p>This event is not normally active - it must be manually enabled and disabled via the USB interrupt register.</p> <p>Remark: This event is not normally active - it must be manually enabled and disabled via the USB interrupt register.</p>
USB_WakeUpCfg	<p>USB_PARAM_CB_T USBD_API_INIT_PARAM::USB_WakeUpCfg</p> <p>Event for remote wake-up configuration, when enabled. This event fires when the USB host request the device to configure itself for remote wake-up capability. The USB host sends this request to device which report remote wake-up capable in their device descriptors, before going to low-power state. The application layer should implement this callback if they have any special on board circuit to trigger remote wake up event. Also application can use this callback to differentiate the following SUSPEND event is caused by cable plug-out or host SUSPEND request. The device can wake-up host only after receiving this callback and remote wake-up feature is enabled by host. To signal remote wake-up the device has to generate resume signaling on bus by calling usapi.hw->WakeUp() routine.</p> <p>Parameters:</p> <ol style="list-style-type: none"> 1. hUsb = Handle to the USB device stack. 2. param1 = When 0 - Clear the wake-up configuration, 1 - Enable the wake-up configuration. <p>Returns:</p> <p>The call back should return ErrorCode_t type to indicate success or error condition.</p>
USB_Power_Event	<p>USB_PARAM_CB_T USBD_API_INIT_PARAM::USB_Power_Event</p> <p>Reserved parameter should be set to zero.</p>
USB_Error_Event	<p>USB_PARAM_CB_T USBD_API_INIT_PARAM::USB_Error_Event</p> <p>Event for error condition. This event fires when USB device controller detect an error condition in the system.</p> <p>Parameters:</p> <ol style="list-style-type: none"> 1. hUsb = Handle to the USB device stack. 2. param1 = USB device interrupt status register. <p>Returns:</p> <p>The call back should return ErrorCode_t type to indicate success or error condition.</p>

Table 509. USBD_API_INIT_PARAM class structure

Member	Description
USB_Configure_Event	<p>USB_CB_T USBD_API_INIT_PARAM::USB_Configure_Event</p> <p>Event for USB configuration number changed. This event fires when a the USB host changes the selected configuration number. On receiving configuration change request from host, the stack enables/configures the endpoints needed by the new configuration before calling this callback function.</p> <p>Remark: This event is called from USB_ISR context and hence is time-critical. Having delays in this callback will prevent the device from enumerating correctly or operate properly.</p>
USB_Interface_Event	<p>USB_CB_T USBD_API_INIT_PARAM::USB_Interface_Event</p> <p>Event for USB interface setting changed. This event fires when a the USB host changes the interface setting to one of alternate interface settings. On receiving interface change request from host, the stack enables/configures the endpoints needed by the new alternate interface setting before calling this callback function.</p> <p>Remark: This event is called from USB_ISR context and hence is time-critical. Having delays in this callback will prevent the device from enumerating correctly or operate properly.</p>
USB_Feature_Event	<p>USB_CB_T USBD_API_INIT_PARAM::USB_Feature_Event</p> <p>Event for USB feature changed. This event fires when a the USB host send set/clear feature request. The stack handles this request for USB_FEATURE_REMOTE_WAKEUP, USB_FEATURE_TEST_MODE and USB_FEATURE_ENDPOINT_STALL features only. On receiving feature request from host, the stack handle the request appropriately and then calls this callback function.</p> <p>Remark: This event is called from USB_ISR context and hence is time-critical. Having delays in this callback will prevent the device from enumerating correctly or operate properly.</p>
virt_to_phys	<p>uint32_t(* USBD_API_INIT_PARAM::virt_to_phys)(void *vaddr)</p> <p>Reserved parameter for future use. should be set to zero.</p>
cache_flush	<p>void(* USBD_API_INIT_PARAM::cache_flush)(uint32_t *start_adr, uint32_t *end_adr)</p> <p>Reserved parameter for future use. should be set to zero.</p>

25.5.27 USBD_CDC_API

CDC class API functions structure. This module exposes functions which interact directly with USB device controller hardware.

Table 510. USBD_CDC_API class structure

Member	Description
GetMemSize	<p>uint32_t(*uint32_t USBD_CDC_API::GetMemSize)(USB_D_CDC_INIT_PARAM_T *param)</p> <p>Function to determine the memory required by the CDC function driver module.</p> <p>This function is called by application layer before calling pUsbApi->CDC->Init(), to allocate memory used by CDC function driver module. The application should allocate the memory which is accessible by USB controller/DMA controller.</p> <p>Remark: Some memory areas are not accessible by all bus masters.</p> <p>Parameters:</p> <ol style="list-style-type: none"> param = Structure containing CDC function driver module initialization parameters. <p>Returns:</p> <p>Returns the required memory size in bytes.</p>

Table 510. USB_D_CDC_API class structure

Member	Description
init	<p>ErrorCode_t(*ErrorCode_t USB_D_CDC_API::init)(USB_D_HANDLE_T hUsb, USB_D_CDC_INIT_PARAM_T *param, USB_D_HANDLE_T *phCDC)</p> <p>Function to initialize CDC function driver module.</p> <p>This function is called by application layer to initialize CDC function driver module.</p> <p>hUsbHandle to the USB device stack. paramStructure containing CDC function driver module initialization parameters.</p> <p>Parameters:</p> <ol style="list-style-type: none"> 1. hUsb = Handle to the USB device stack. 2. param = Structure containing CDC function driver module initialization parameters. <p>Returns:</p> <p>Returns ErrorCode_t type to indicate success or error condition.</p> <p>Return values:</p> <ol style="list-style-type: none"> 1. LPC_OK = On success 2. ERR_USB_D_BAD_MEM_BUF = Memory buffer passed is not 4-byte aligned or smaller than required. 3. ERR_API_INVALID_PARAM2 = Either CDC_Write() or CDC_Read() or CDC_Verify() callbacks are not defined. 4. ERR_USB_D_BAD_INTF_DESC = Wrong interface descriptor is passed. 5. ERR_USB_D_BAD_EP_DESC = Wrong endpoint descriptor is passed.
SendNotification	<p>ErrorCode_t(*ErrorCode_t USB_D_CDC_API::SendNotification)(USB_D_HANDLE_T hCdc, uint8_t bNotification, uint16_t data)</p> <p>Function to send CDC class notifications to host.</p> <p>This function is called by application layer to send CDC class notifications to host. See usbcdc11.pdf, section 6.3, Table 67 for various notification types the CDC device can send.</p> <p>Remark: The current version of the driver only supports following notifications allowed by ACM subclass: CDC_NOTIFICATION_NETWORK_CONNECTION, CDC_RESPONSE_AVAILABLE, CDC_NOTIFICATION_SERIAL_STATE. For all other notifications application should construct the notification buffer appropriately and call hw->USB_WriteEP() for interrupt endpoint associated with the interface.</p> <p>Parameters:</p> <ol style="list-style-type: none"> 1. hCdc = Handle to CDC function driver. 2. bNotification = Notification type allowed by ACM subclass. Should be CDC_NOTIFICATION_NETWORK_CONNECTION, CDC_RESPONSE_AVAILABLE or CDC_NOTIFICATION_SERIAL_STATE. For all other types ERR_API_INVALID_PARAM2 is returned. See usbcdc11.pdf, section 3.6.2.1, table 5. 3. data = Data associated with notification. For CDC_NOTIFICATION_NETWORK_CONNECTION a non-zero data value is interpreted as connected state. For CDC_RESPONSE_AVAILABLE this parameter is ignored. For CDC_NOTIFICATION_SERIAL_STATE the data should use bitmap values defined in usbcdc11.pdf, section 6.3.5, Table 69. <p>Returns:</p> <p>Returns ErrorCode_t type to indicate success or error condition.</p> <p>Return values:</p> <ol style="list-style-type: none"> 1. LPC_OK = On success 2. ERR_API_INVALID_PARAM2 = If unsupported notification type is passed.

25.5.28 USB_D_CDC_INIT_PARAM

Communication Device Class function driver initialization parameter data structure.

Table 511. USBDCDCINITPARAM class structure

Member	Description
mem_base	<p>uint32_t USBDCDCINITPARAM::mem_base</p> <p>Base memory location from where the stack can allocate data and buffers.</p> <p>Remark: The memory address set in this field should be accessible by USB DMA controller. Also this value should be aligned on 4 byte boundary.</p>
mem_size	<p>uint32_t USBDCDCINITPARAM::mem_size</p> <p>The size of memory buffer which stack can use.</p> <p>Remark: The mem_size should be greater than the size returned by USBDCDCAPI::GetMemSize() routine.</p>
cif_intf_desc	<p>uint8_t * USBDCDCINITPARAM::cif_intf_desc</p> <p>Pointer to the control interface descriptor within the descriptor array</p>
dif_intf_desc	<p>uint8_t * USBDCDCINITPARAM::dif_intf_desc</p> <p>Pointer to the data interface descriptor within the descriptor array</p>
CIC_GetRequest	<p>ErrorCode_t(* USBDCDCINITPARAM::CIC_GetRequest)(USB_HANDLE_T hHid, USB_SETUP_PACKET *pSetup, uint8_t **pBuffer, uint16_t *length)</p> <p>Communication Interface Class specific get request call-back function.</p> <p>This function is provided by the application software. This function gets called when host sends CIC management element get requests.</p> <p>Remark: Applications implementing Abstract Control Model subclass can set this param to NULL. As the default driver parses ACM requests and calls the individual ACM call-back routines defined in this structure. For all other subclasses this routine should be provided by the application. The setup packet data (pSetup) is passed to the call-back so that application can extract the CIC request type and other associated data. By default the stack will assign pBuffer pointer to EP0Buff allocated at init. The application code can directly write data into this buffer as long as data is less than 64 byte. If more data has to be sent then application code should update pBuffer pointer and length accordingly.</p> <p>Parameters:</p> <ol style="list-style-type: none"> hCdc = Handle to CDC function driver. pSetup = Pointer to setup packet received from host. pBuffer = Pointer to a pointer of data buffer containing request data. Pointer-to-pointer is used to implement zero-copy buffers. See USBDCDCZeroCopy for more details on zero-copy concept. length = Amount of data to be sent back to host. <p>Returns:</p> <p>The call back should returns ErrorCode_t type to indicate success or error condition.</p> <p>Return values:</p> <ol style="list-style-type: none"> LPC_OK = On success. ERR_USBDCDC_UNHANDLED = Event is not handled hence pass the event to next in line. ERR_USBDCDC_XXX = For other error conditions.

Table 511. USBD_CDC_INIT_PARAM class structure

Member	Description
CIC_SetRequest	<p>ErrorCode_t(* USBD_CDC_INIT_PARAM::CIC_SetRequest)(USB_HANDLE_T hCdc, USB_SETUP_PACKET *pSetup, uint8_t **pBuffer, uint16_t length)</p> <p>Communication Interface Class specific set request call-back function.</p> <p>This function is provided by the application software. This function gets called when host sends a CIC management element requests.</p> <p>Remark: Applications implementing Abstract Control Model subclass can set this param to NULL. As the default driver parses ACM requests and calls the individual ACM call-back routines defined in this structure. For all other subclasses this routine should be provided by the application. The setup packet data (pSetup) is passed to the call-back so that application can extract the CIC request type and other associated data. If a set request has data associated, then this call-back is called twice. (1) First when setup request is received, at this time application code could update pBuffer pointer to point to the intended destination. The length param is set to 0 so that application code knows this is first time. By default the stack will assign pBuffer pointer to EP0Buff allocated at init. Note, if data length is greater than 64 bytes and application code doesn't update pBuffer pointer the stack will send STALL condition to host. (2) Second when the data is received from the host. This time the length param is set with number of data bytes received.</p> <p>Parameters:</p> <ol style="list-style-type: none"> 1. hCdc = Handle to CDC function driver. 2. pSetup = Pointer to setup packet received from host. 3. pBuffer = Pointer to a pointer of data buffer containing request data. Pointer-to-pointer is used to implement zero-copy buffers. See USBD_ZeroCopy for more details on zero-copy concept. 4. length = Amount of data copied to destination buffer. <p>Returns:</p> <p>The call back should returns ErrorCode_t type to indicate success or error condition.</p> <p>Return values:</p> <ol style="list-style-type: none"> 1. LPC_OK = On success. 2. ERR_USBD_UNHANDLED = Event is not handled hence pass the event to next in line. 3. ERR_USBD_xxx = For other error conditions.
CDC_BulkIN_Hdlr	<p>ErrorCode_t(* USBD_CDC_INIT_PARAM::CDC_BulkIN_Hdlr)(USB_HANDLE_T hUsb, void *data, uint32_t event)</p> <p>Communication Device Class specific BULK IN endpoint handler.</p> <p>The application software should provide the BULK IN endpoint handler. Applications should transfer data depending on the communication protocol type set in descriptors.</p> <p>Remark:</p> <p>Parameters:</p> <ol style="list-style-type: none"> 1. hUsb = Handle to the USB device stack. 2. data = Pointer to the data which will be passed when callback function is called by the stack. 3. event = Type of endpoint event. See USBD_EVENT_T for more details. <p>Returns:</p> <p>The call back should returns ErrorCode_t type to indicate success or error condition.</p> <p>Return values:</p> <ol style="list-style-type: none"> 1. LPC_OK = On success. 2. ERR_USBD_UNHANDLED = Event is not handled hence pass the event to next in line. 3. ERR_USBD_xxx = For other error conditions.

Table 511. USBDCDC_INIT_PARAM class structure

Member	Description
CDC_BulkOUT_Hdtr	<p>ErrorCode_t(* USBDCDC_INIT_PARAM::CDC_BulkOUT_Hdtr)(USBDCDC_HANDLE_T hUsb, void *data, uint32_t event)(USBDCDC_HANDLE_T hUsb, void *data, uint32_t event)</p> <p>Communication Device Class specific BULK OUT endpoint handler.</p> <p>The application software should provide the BULK OUT endpoint handler. Applications should transfer data depending on the communication protocol type set in descriptors.</p> <p>Remark:</p> <p>Parameters:</p> <ol style="list-style-type: none"> 1. hUsb = Handle to the USB device stack. 2. data = Pointer to the data which will be passed when callback function is called by the stack. 3. event = Type of endpoint event. See USBDCDC_EVENT_T for more details. <p>Returns:</p> <p>The call back should returns ErrorCode_t type to indicate success or error condition.</p> <p>Return values:</p> <ol style="list-style-type: none"> 1. LPC_OK = On success. 2. ERR_USBD_UNHANDLED = Event is not handled hence pass the event to next in line. 3. ERR_USBD_xxx = For other error conditions.
SendEncpsCmd	<p>ErrorCode_t(* USBDCDC_INIT_PARAM::SendEncpsCmd)(USBDCDC_HANDLE_T hCDC, uint8_t *buffer, uint16_t len)</p> <p>Abstract control model(ACM) subclass specific SEND_ENCAPSULATED_COMMAND request call-back function.</p> <p>This function is provided by the application software. This function gets called when host sends a SEND_ENCAPSULATED_COMMAND set request.</p> <p>Parameters:</p> <ol style="list-style-type: none"> 1. hCdc = Handle to CDC function driver. 2. buffer = Pointer to the command buffer. 3. len = Length of the command buffer. <p>Returns:</p> <p>The call back should returns ErrorCode_t type to indicate success or error condition.</p> <p>Return values:</p> <ol style="list-style-type: none"> 1. LPC_OK = On success. 2. ERR_USBD_UNHANDLED = Event is not handled hence pass the event to next in line. 3. ERR_USBD_xxx = For other error conditions.

Table 511. USB_D_CDC_INIT_PARAM class structure

Member	Description
GetEncpsResp	<p>ErrorCode_t(* USB_D_CDC_INIT_PARAM::GetEncpsResp)(USB_D_HANDLE_T hCDC, uint8_t **buffer, uint16_t *len)</p> <p>Abstract control model(ACM) subclass specific GET_ENCAPSULATED_RESPONSE request call-back function.</p> <p>This function is provided by the application software. This function gets called when host sends a GET_ENCAPSULATED_RESPONSE request.</p> <p>Parameters:</p> <ol style="list-style-type: none"> 1. hCdc = Handle to CDC function driver. 2. buffer = Pointer to a pointer of data buffer containing response data. Pointer-to-pointer is used to implement zero-copy buffers. See USB_D_ZeroCopy for more details on zero-copy concept. 3. len = Amount of data to be sent back to host. <p>Returns:</p> <p>The call back should returns ErrorCode_t type to indicate success or error condition.</p> <p>Return values:</p> <ol style="list-style-type: none"> 1. LPC_OK = On success. 2. ERR_USB_D_UNHANDLED = Event is not handled hence pass the event to next in line. 3. ERR_USB_D_xxx = For other error conditions.
SetCommFeature	<p>ErrorCode_t(* USB_D_CDC_INIT_PARAM::SetCommFeature)(USB_D_HANDLE_T hCDC, uint16_t feature, uint8_t *buffer, uint16_t len)</p> <p>Abstract control model(ACM) subclass specific SET_COMM_FEATURE request call-back function.</p> <p>This function is provided by the application software. This function gets called when host sends a SET_COMM_FEATURE set request.</p> <p>Parameters:</p> <ol style="list-style-type: none"> 1. hCdc = Handle to CDC function driver. 2. feature = Communication feature type. 3. buffer = Pointer to the settings buffer for the specified communication feature. 4. len = Length of the request buffer. <p>Returns:</p> <p>The call back should returns ErrorCode_t type to indicate success or error condition.</p> <p>Return values:</p> <ol style="list-style-type: none"> 1. LPC_OK = On success. 2. ERR_USB_D_UNHANDLED = Event is not handled hence pass the event to next in line. 3. ERR_USB_D_xxx = For other error conditions.

Table 511. USB_D_CDC_INIT_PARAM class structure

Member	Description
GetCommFeature	<p>ErrorCode_t(* USB_D_CDC_INIT_PARAM::GetCommFeature)(USB_D_HANDLE_T hCDC, uint16_t feature, uint8_t **pBuffer, uint16_t *len)</p> <p>Abstract control model(ACM) subclass specific GET_COMM_FEATURE request call-back function.</p> <p>This function is provided by the application software. This function gets called when host sends a GET_ENCAPSULATED_RESPONSE request.</p> <p>Parameters:</p> <ol style="list-style-type: none"> 1. hCdc = Handle to CDC function driver. 2. feature = Communication feature type. 3. buffer = Pointer to a pointer of data buffer containing current settings for the communication feature. Pointer-to-pointer is used to implement zero-copy buffers. 4. len = Amount of data to be sent back to host. <p>Returns:</p> <p>The call back should returns ErrorCode_t type to indicate success or error condition.</p> <p>Return values:</p> <ol style="list-style-type: none"> 1. LPC_OK = On success. 2. ERR_USBD_UNHANDLED = Event is not handled hence pass the event to next in line. 3. ERR_USBD_xxx = For other error conditions.

Table 511. USBDCDC_INIT_PARAM class structure

Member	Description
ClrCommFeature	<p>ErrorCode_t(* USBDCDC_INIT_PARAM::ClrCommFeature)(USBDCDC_HANDLE_T hCDC, uint16_t feature)</p> <p>Abstract control model(ACM) subclass specific CLEAR_COMM_FEATURE request call-back function.</p> <p>This function is provided by the application software. This function gets called when host sends a CLEAR_COMM_FEATURE request. In the call-back the application should Clears the settings for a particular communication feature.</p> <p>Parameters:</p> <ol style="list-style-type: none"> 1. hCdc = Handle to CDC function driver. 2. feature = Communication feature type. See usbdcdc11.pdf, section 6.2.4, Table 47. <p>Returns:</p> <p>The call back should returns ErrorCode_t type to indicate success or error condition.</p> <p>Return values:</p> <ol style="list-style-type: none"> 1. LPC_OK = On success. 2. ERR_USBD_UNHANDLED = Event is not handled hence pass the event to next in line. 3. ERR_USBD_XXX = For other error conditions.

Table 511. USB_D_CDC_INIT_PARAM class structure

Member	Description
SetCtrlLineState	<p>ErrorCode_t(* USB_D_CDC_INIT_PARAM::SetCtrlLineState)(USB_D_HANDLE_T hCDC, uint16_t state)</p> <p>Abstract control model(ACM) subclass specific SET_CONTROL_LINE_STATE request call-back function.</p> <p>This function is provided by the application software. This function gets called when host sends a SET_CONTROL_LINE_STATE request. RS-232 signal used to tell the DCE device the DTE device is now present</p> <p>Parameters:</p> <ol style="list-style-type: none"> 1. hCdc = Handle to CDC function driver. 2. state = The state value uses bitmap values defined the <i>USB CDC class specification document</i> published by usb.org. <p>Returns:</p> <p>The call back should returns ErrorCode_t type to indicate success or error condition.</p> <p>Return values:</p> <ol style="list-style-type: none"> 1. LPC_OK = On success. 2. ERR_USBD_UNHANDLED = Event is not handled hence pass the event to next in line. 3. ERR_USBD_xxx = For other error conditions.
SendBreak	<p>ErrorCode_t(* USB_D_CDC_INIT_PARAM::SendBreak)(USB_D_HANDLE_T hCDC, uint16_t mstime)</p> <p>Abstract control model(ACM) subclass specific SEND_BREAK request call-back function.</p> <p>This function is provided by the application software. This function gets called when host sends a SEND_BREAK request.</p> <p>Parameters:</p> <ol style="list-style-type: none"> 1. hCdc = Handle to CDC function driver. 2. mstime = Duration of Break signal in milliseconds. If mstime is FFFFh, then the application should send break until another SendBreak request is received with the wValue of 0000h. <p>Returns:</p> <p>The call back should returns ErrorCode_t type to indicate success or error condition.</p> <p>Return values:</p> <ol style="list-style-type: none"> 1. LPC_OK = On success. 2. ERR_USBD_UNHANDLED = Event is not handled hence pass the event to next in line. 3. ERR_USBD_xxx = For other error conditions.

Table 511. USBD_CDC_INIT_PARAM class structure

Member	Description
SetLineCode	<p>ErrorCode_t(* USBD_CDC_INIT_PARAM::SetLineCode)(USBD_HANDLE_T hCDC, CDC_LINE_CODING *line_coding)</p> <p>Abstract control model(ACM) subclass specific SET_LINE_CODING request call-back function.</p> <p>This function is provided by the application software. This function gets called when host sends a SET_LINE_CODING request. The application should configure the device per DTE rate, stop-bits, parity, and number-of-character bits settings provided in command buffer.</p> <p>Parameters:</p> <ol style="list-style-type: none"> 1. hCdc = Handle to CDC function driver. 2. line_coding = Pointer to the CDC_LINE_CODING command buffer. <p>Returns:</p> <p>The call back should returns ErrorCode_t type to indicate success or error condition.</p> <p>Return values:</p> <ol style="list-style-type: none"> 1. LPC_OK = On success. 2. ERR_USBD_UNHANDLED = Event is not handled hence pass the event to next in line. 3. ERR_USBD_xxx = For other error conditions.
CDC_InterruptEP_Hdlr	<p>ErrorCode_t(* USBD_CDC_INIT_PARAM::CDC_InterruptEP_Hdlr)(USBD_HANDLE_T hUsb, void *data, uint32_t event)</p> <p>Optional Communication Device Class specific INTERRUPT IN endpoint handler.</p> <p>The application software should provide the INT IN endpoint handler. Applications should transfer data depending on the communication protocol type set in descriptors.</p> <p>Parameters:</p> <ol style="list-style-type: none"> 1. hUsb = Handle to the USB device stack. 2. data = Pointer to the data which will be passed when callback function is called by the stack. 3. event = Type of endpoint event. See USBD_EVENT_T for more details. <p>Returns:</p> <p>The call back should returns ErrorCode_t type to indicate success or error condition.</p> <p>Return values:</p> <ol style="list-style-type: none"> 1. LPC_OK = On success. 2. ERR_USBD_UNHANDLED = Event is not handled hence pass the event to next in line. 3. ERR_USBD_xxx = For other error conditions.

Table 511. USBD_CDC_INIT_PARAM class structure

Member	Description
CDC_Ep0_Hdlr	<p>ErrorCode_t(* USBD_CDC_INIT_PARAM::CDC_Ep0_Hdlr)(USB_HANDLE_T hUsb, void *data, uint32_t event)</p> <p>Optional user override-able function to replace the default CDC class handler.</p> <p>The application software could override the default EP0 class handler with their own by providing the handler function address as this data member of the parameter structure. Application which like the default handler should set this data member to zero before calling the USBD_CDC_API::Init().</p> <p>Parameters:</p> <ol style="list-style-type: none"> 1. hUsb = Handle to the USB device stack. 2. data = Pointer to the data which will be passed when callback function is called by the stack. 3. event = Type of endpoint event. See USBD_EVENT_T for more details. <p>Returns:</p> <p>The call back should returns ErrorCode_t type to indicate success or error condition.</p> <p>Return values:</p> <ol style="list-style-type: none"> 1. LPC_OK = On success. 2. ERR_USB_UNHANDLED = Event is not handled hence pass the event to next in line. 3. ERR_USB_xxx = For other error conditions.

25.5.29 USBD_CORE_API

USB stack Core API functions structure.

Table 512. USBD_CORE_API class structure

Member	Description
RegisterClassHandler	<p>ErrorCode_t(* USBD_CORE_API::RegisterClassHandler)(USB_HANDLE_T hUsb, USB_EP_HANDLER_T pfn, void *data)</p> <p>Function to register class specific EP0 event handler with USB device stack.</p> <p>The application layer uses this function when it has to register the custom class's EP0 handler. The stack calls all the registered class handlers on any EP0 event before going through default handling of the event. This gives the class handlers to implement class specific request handlers and also to override the default stack handling for a particular event targeted to the interface. Check USB_EP_HANDLER_T for more details on how the callback function should be implemented. Also application layer could use this function to register EP0 handler which responds to vendor specific requests.</p> <p>Parameters:</p> <ol style="list-style-type: none"> 1. hUsb = Handle to the USB device stack. 2. pfn = Class specific EP0 handler function. 3. data = Pointer to the data which will be passed when callback function is called by the stack. <p>Returns:</p> <p>Returns ErrorCode_t type to indicate success or error condition.</p> <p>Return values:</p> <ol style="list-style-type: none"> 1. LPC_OK = On success 2. ERR_USB_TOO_MANY_CLASS_HDLR(0x0004000c) = The number of class handlers registered is greater than the number of handlers allowed by the stack.

Table 512. USBD_CORE_API class structure

Member	Description
RegisterEpHandler	<p>ErrorCode_t(*ErrorCode_t USBD_CORE_API::RegisterEpHandler)(USB_HANDLE_T hUsb, uint32_t ep_index, USB_EP_HANDLER_T pfn, void *data)</p> <p>Function to register interrupt/event handler for the requested endpoint with USB device stack. The application layer uses this function to register the custom class's EP0 handler. The stack calls all the registered class handlers on any EP0 event before going through default handling of the event. This gives the class handlers to implement class specific request handlers and also to override the default stack handling for a particular event targeted to the interface. Check USB_EP_HANDLER_T for more details on how the callback function should be implemented.</p> <p>Parameters:</p> <ol style="list-style-type: none"> 1. hUsb = Handle to the USB device stack. 2. ep_index = Class specific EP0 handler function. 3. pfn = Class specific EP0 handler function. 4. data = Pointer to the data which will be passed when callback function is called by the stack. <p>Returns:</p> <p>Returns ErrorCode_t type to indicate success or error condition.</p> <p>Return values:</p> <ol style="list-style-type: none"> 1. LPC_OK = On success 2. ERR_USB_TOO_MANY_CLASS_HDLR(0x0004000c) = Too many endpoint handlers.
SetupStage	<p>void(*void USBD_CORE_API::SetupStage)(USB_HANDLE_T hUsb)</p> <p>Function to set EP0 state machine in setup state.</p> <p>This function is called by USB stack and the application layer to set the EP0 state machine in setup state. This function will read the setup packet received from USB host into stack's buffer.</p> <p>Remark: This interface is provided to users to invoke this function in other scenarios which are not handle by current stack. In most user applications this function is not called directly. Also this function can be used by users who are selectively modifying the USB device stack's standard handlers through callback interface exposed by the stack.</p> <p>Parameters:</p> <ol style="list-style-type: none"> 1. hUsb = Handle to the USB device stack. <p>Returns:</p> <p>Nothing.</p>
DataInStage	<p>void(*void USBD_CORE_API::DataInStage)(USB_HANDLE_T hUsb)</p> <p>Function to set EP0 state machine in data_in state.</p> <p>This function is called by USB stack and the application layer to set the EP0 state machine in data_in state. This function will write the data present in EP0Data buffer to EP0 FIFO for transmission to host.</p> <p>Remark: This interface is provided to users to invoke this function in other scenarios which are not handle by current stack. In most user applications this function is not called directly. Also this function can be used by users who are selectively modifying the USB device stack's standard handlers through callback interface exposed by the stack.</p> <p>Parameters:</p> <ol style="list-style-type: none"> 1. hUsb = Handle to the USB device stack. <p>Returns:</p> <p>Nothing.</p>

Table 512. USBD_CORE_API class structure

Member	Description
DataOutStage	<p>void(*void USBD_CORE_API::DataOutStage)(USB_HANDLE_T hUsb)</p> <p>Function to set EPO state machine in data_out state.</p> <p>This function is called by USB stack and the application layer to set the EPO state machine in data_out state. This function will read the control data (EPO out packets) received from USB host into EP0Data buffer.</p> <p>Remark: This interface is provided to users to invoke this function in other scenarios which are not handle by current stack. In most user applications this function is not called directly. Also this function can be used by users who are selectively modifying the USB device stack's standard handlers through callback interface exposed by the stack.</p> <p>Parameters:</p> <ol style="list-style-type: none"> 1. hUsb = Handle to the USB device stack. <p>Returns:</p> <p>Nothing.</p>
StatusInStage	<p>void(*void USBD_CORE_API::StatusInStage)(USB_HANDLE_T hUsb)</p> <p>Function to set EPO state machine in status_in state.</p> <p>This function is called by USB stack and the application layer to set the EPO state machine in status_in state. This function will send zero length IN packet on EP0 to host, indicating positive status.</p> <p>Remark: This interface is provided to users to invoke this function in other scenarios which are not handle by current stack. In most user applications this function is not called directly. Also this function can be used by users who are selectively modifying the USB device stack's standard handlers through callback interface exposed by the stack.</p> <p>Parameters:</p> <ol style="list-style-type: none"> 1. hUsb = Handle to the USB device stack. <p>Returns:</p> <p>Nothing.</p>
StatusOutStage	<p>void(*void USBD_CORE_API::StatusOutStage)(USB_HANDLE_T hUsb)</p> <p>Function to set EPO state machine in status_out state.</p> <p>This function is called by USB stack and the application layer to set the EPO state machine in status_out state. This function will read the zero length OUT packet received from USB host on EP0.</p> <p>Remark: This interface is provided to users to invoke this function in other scenarios which are not handle by current stack. In most user applications this function is not called directly. Also this function can be used by users who are selectively modifying the USB device stack's standard handlers through callback interface exposed by the stack.</p> <p>Parameters:</p> <ol style="list-style-type: none"> 1. hUsb = Handle to the USB device stack. <p>Returns:</p> <p>Nothing.</p>

Table 512. USBD_CORE_API class structure

Member	Description
StallEp0	<p>void(*void USBD_CORE_API::StallEp0)(USB_HANDLE_T hUsb)</p> <p>Function to set EPO state machine in stall state.</p> <p>This function is called by USB stack and the application layer to generate STALL signalling on EPO endpoint. This function will also reset the EPOData buffer.</p> <p>Remark: This interface is provided to users to invoke this function in other scenarios which are not handle by current stack. In most user applications this function is not called directly. Also this function can be used by users who are selectively modifying the USB device stack's standard handlers through callback interface exposed by the stack.</p> <p>Parameters:</p> <ol style="list-style-type: none">1. hUsb = Handle to the USB device stack. <p>Returns:</p> <p>Nothing.</p>

25.5.30 USBD_DFU_API

DFU class API functions structure. This module exposes functions which interact directly with USB device controller hardware.

Table 513. USB_DFU_API class structure

Member	Description
GetMemSize	<p>uint32_t(*uint32_t USB_DFU_API::GetMemSize)(USB_DFU_INIT_PARAM_T *param)</p> <p>Function to determine the memory required by the DFU function driver module.</p> <p>This function is called by application layer before calling pUsbApi->dfu->Init(), to allocate memory used by DFU function driver module. The application should allocate the memory which is accessible by USB controller/DMA controller.</p> <p>Remark: Some memory areas are not accessible by all bus masters.</p> <p>Parameters:</p> <ol style="list-style-type: none"> 1. param = Structure containing DFU function driver module initialization parameters. <p>Returns:</p> <p>Returns the required memory size in bytes.</p>
init	<p>ErrorCode_t(*ErrorCode_t USB_DFU_API::init)(USB_HANDLE_T hUsb, USB_DFU_INIT_PARAM_T *param, uint32_t init_state)</p> <p>Function to initialize DFU function driver module.</p> <p>This function is called by application layer to initialize DFU function driver module.</p> <p>Parameters:</p> <ol style="list-style-type: none"> 1. hUsb = Handle to the USB device stack. 2. param = Structure containing DFU function driver module initialization parameters. <p>Returns:</p> <p>Returns ErrorCode_t type to indicate success or error condition.</p> <p>Return values:</p> <ol style="list-style-type: none"> 1. LPC_OK = On success 2. ERR_USBD_BAD_MEM_BUF = Memory buffer passed is not 4-byte aligned or smaller than required. 3. ERR_API_INVALID_PARAM2 = Either DFU_Write() or DFU_Done() or DFU_Read() callbacks are not defined. 4. ERR_USBD_BAD_DESC = USB_DFU_DESCRIPTOR_TYPE is not defined immediately after interface descriptor.wTransferSize in descriptor doesn't match the value passed in param->wTransferSize.DFU_Detach() is not defined while USB_DFU_WILL_DETACH is set in DFU descriptor. 5. ERR_USBD_BAD_INTF_DESC = Wrong interface descriptor is passed.

25.5.31 USB_DFU_INIT_PARAM

USB descriptors data structure.

Table 514. USB_DFU_INIT_PARAM class structure

Member	Description
mem_base	<p>uint32_t USB_DFU_INIT_PARAM::mem_base</p> <p>Base memory location from where the stack can allocate data and buffers.</p> <p>Remark: The memory address set in this field should be accessible by USB DMA controller. Also this value should be aligned on 4 byte boundary.</p>
mem_size	<p>uint32_t USB_DFU_INIT_PARAM::mem_size</p> <p>The size of memory buffer which stack can use.</p> <p>Remark: The mem_size should be greater than the size returned by USB_DFU_API::GetMemSize() routine.</p>

Table 514. USB_DFU_INIT_PARAM class structure

Member	Description
wTransferSize	uint16_t USB_DFU_INIT_PARAM::wTransferSize DFU transfer block size in number of bytes. This value should match the value set in DFU descriptor provided as part of the descriptor array (
pad	uint16_t USB_DFU_INIT_PARAM::pad
intf_desc	uint8_t * USB_DFU_INIT_PARAM::intf_desc Pointer to the DFU interface descriptor within the descriptor array (
DFU_Write	uint8_t(*uint8_t(* USB_DFU_INIT_PARAM::DFU_Write)(uint32_t block_num, uint8_t **src, uint32_t length, uint8_t *bwPollTimeout))(uint32_t block_num, uint8_t **src, uint32_t length, uint8_t *bwPollTimeout) DFU Write callback function. This function is provided by the application software. This function gets called when host sends a write command. For application using zero-copy buffer scheme this function is called for the first time with Parameters: <ol style="list-style-type: none"> 1. block_num = Destination start address. 2. src = Pointer to a pointer to the source of data. Pointer-to-pointer is used to implement zero-copy buffers. See Zero-Copy Data Transfer model for more details on zero-copy concept. 3. bwPollTimeout = Pointer to a 3 byte buffer which the callback implementer should fill with the amount of minimum time, in milliseconds, that the host should wait before sending a subsequent DFU_GETSTATUS request. 4. length = Number of bytes to be written. Returns: Returns DFU_STATUS_ values defined in mw_usbd_dfu.h.
DFU_Read	uint32_t(*uint32_t(* USB_DFU_INIT_PARAM::DFU_Read)(uint32_t block_num, uint8_t **dst, uint32_t length))(uint32_t block_num, uint8_t **dst, uint32_t length) DFU Read callback function. This function is provided by the application software. This function gets called when host sends a read command. Parameters: <ol style="list-style-type: none"> 1. block_num = Destination start address. 2. dst = Pointer to a pointer to the source of data. Pointer-to-pointer is used to implement zero-copy buffers. See Zero-Copy Data Transfer model for more details on zero-copy concept. 3. length = Amount of data copied to destination buffer. Returns: Returns DFU_STATUS_ values defined in mw_usbd_dfu.h.
DFU_Done	void(*USB_DFU_INIT_PARAM::DFU_Done)(void) DFU done callback function. This function is provided by the application software. This function gets called after download is finished. Nothing. Returns: Nothing.

Table 514. USB_DFU_INIT_PARAM class structure

Member	Description
DFU_Detach	<p>void(* USB_DFU_INIT_PARAM::DFU_Detach)(USB_HANDLE_T hUsb)</p> <p>DFU detach callback function.</p> <p>This function is provided by the application software. This function gets called after USB_REQ_DFU_DETACH is received. Applications which set USB_DFU_WILL_DETACH bit in DFU descriptor should define this function. As part of this function application can call Connect() routine to disconnect and then connect back with host. For application which rely on WinUSB based host application should use this feature since USB reset can be invoked only by kernel drivers on Windows host. By implementing this feature host doesn't have to issue reset instead the device has to do it automatically by disconnect and connect procedure.</p> <p>hUsbHandle DFU control structure.</p> <p>Parameters:</p> <ol style="list-style-type: none"> 1. hUsb = Handle DFU control structure. <p>Returns:</p> <p>Nothing.</p>
DFU_Ep0_Hdlr	<p>ErrorCode_t(* USB_DFU_INIT_PARAM::DFU_Ep0_Hdlr)(USB_HANDLE_T hUsb, void *data, uint32_t event)</p> <p>Optional user overridable function to replace the default DFU class handler.</p> <p>The application software could override the default EP0 class handler with their own by providing the handler function address as this data member of the parameter structure. Application which like the default handler should set this data member to zero before calling the USB_DFU_API::Init().</p> <p>Remark:</p> <p>Parameters:</p> <ol style="list-style-type: none"> 1. hUsb = Handle to the USB device stack. 2. data = Pointer to the data which will be passed when callback function is called by the stack. 3. event = Type of endpoint event. See USB_EVENT_T for more details. <p>Returns:</p> <p>The call back should returns ErrorCode_t type to indicate success or error condition.</p> <p>Return values:</p> <ol style="list-style-type: none"> 1. LPC_OK = On success. 2. ERR_USBD_UNHANDLED = Event is not handled hence pass the event to next in line. 3. ERR_USBD_xxx = For other error conditions.

25.5.32 USB_HID_API

HID class API functions structure. This structure contains pointers to all the function exposed by HID function driver module.

Table 515. USBD_HID_API class structure

Member	Description
GetMemSize	<p>uint32_t(*uint32_t USBD_HID_API::GetMemSize)(USB_D_HANDLE_T hUsb, USBD_HID_INIT_PARAM_T *param)</p> <p>Function to determine the memory required by the HID function driver module.</p> <p>This function is called by application layer before calling pUsbApi->hid->Init(), to allocate memory used by HID function driver module. The application should allocate the memory which is accessible by USB controller/DMA controller.</p> <p>Remark: Some memory areas are not accessible by all bus masters.</p> <p>Parameters:</p> <ol style="list-style-type: none"> 1. param = Structure containing HID function driver module initialization parameters. <p>Returns:</p> <p>Returns the required memory size in bytes.</p>
init	<p>ErrorCode_t(*ErrorCode_t USBD_HID_API::init)(USB_D_HANDLE_T hUsb, USBD_HID_INIT_PARAM_T *param)</p> <p>Function to initialize HID function driver module.</p> <p>This function is called by application layer to initialize HID function driver module. On successful initialization the function returns a handle to HID function driver module in passed param structure.</p> <p>Parameters:</p> <ol style="list-style-type: none"> 1. hUsb = Handle to the USB device stack. 2. param = Structure containing HID function driver module initialization parameters. <p>Returns:</p> <p>Returns ErrorCode_t type to indicate success or error condition.</p> <p>Return values:</p> <ol style="list-style-type: none"> 1. LPC_OK = On success 2. ERR_USBD_BAD_MEM_BUF = Memory buffer passed is not 4-byte aligned or smaller than required. 3. ERR_API_INVALID_PARAM2 = Either HID_GetReport() or HID_SetReport() callback are not defined. 4. ERR_USBD_BAD_DESC = HID_HID_DESCRIPTOR_TYPE is not defined immediately after interface descriptor. 5. ERR_USBD_BAD_INTF_DESC = Wrong interface descriptor is passed. 6. ERR_USBD_BAD_EP_DESC = Wrong endpoint descriptor is passed.

25.5.33 USBD_HID_INIT_PARAM

USB descriptors data structure.

Table 516. USB_D_HID_INIT_PARAM class structure

Member	Description
mem_base	uint32_t USB_D_HID_INIT_PARAM::mem_base Base memory location from where the stack can allocate data and buffers. Remark: The memory address set in this field should be accessible by USB DMA controller. Also this value should be aligned on 4 byte boundary.
mem_size	uint32_t USB_D_HID_INIT_PARAM::mem_size The size of memory buffer which stack can use. Remark: The mem_size should be greater than the size returned by USB_D_HID_API::GetMemSize() routine.
max_reports	uint8_t USB_D_HID_INIT_PARAM::max_reports Number of HID reports supported by this instance of HID class driver.
pad	uint8_t USB_D_HID_INIT_PARAM::pad[3][3]
intf_desc	uint8_t * USB_D_HID_INIT_PARAM::intf_desc Pointer to the HID interface descriptor within the descriptor array (
report_data	USB_HID_REPORT_T *USB_HID_REPORT_T* USB_D_HID_INIT_PARAM::report_data Pointer to an array of HID report descriptor data structure (Remark: This array should be of global scope.
HID_GetReport	ErrorCode_t(* USB_D_HID_INIT_PARAM::HID_GetReport)(USB_D_HANDLE_T hHid, USB_SETUP_PACKET *pSetup, uint8_t **pBuffer, uint16_t *length) HID get report callback function. This function is provided by the application software. This function gets called when host sends a HID_REQUEST_GET_REPORT request. The setup packet data (Remark: HID reports are sent via interrupt IN endpoint also. This function is called only when report request is received on control endpoint. Application should implement HID_EpIn_Hdlr to send reports to host via interrupt IN endpoint. Parameters: <ol style="list-style-type: none"> 1. hHid = Handle to HID function driver. 2. pSetup = Pointer to setup packet received from host. 3. pBuffer = Pointer to a pointer of data buffer containing report data. Pointer-to-pointer is used to implement zero-copy buffers. See Zero-Copy Data Transfer model for more details on zero-copy concept. 4. length = Amount of data copied to destination buffer. Returns: The call back should returns ErrorCode_t type to indicate success or error condition. Return values: <ol style="list-style-type: none"> 1. LPC_OK = On success. 2. ERR_USB_D_UNHANDLED = Event is not handled hence pass the event to next in line. 3. ERR_USB_D_XXX = For other error conditions.

Table 516. USBD_HID_INIT_PARAM class structure

Member	Description
HID_SetReport	<p>ErrorCode_t(* USBD_HID_INIT_PARAM::HID_SetReport)(USB_HANDLE_T hHid, USB_SETUP_PACKET *pSetup, uint8_t **pBuffer, uint16_t length)</p> <p>HID set report callback function.</p> <p>This function is provided by the application software. This function gets called when host sends a HID_REQUEST_SET_REPORT request. The setup packet data (</p> <p>Parameters:</p> <ol style="list-style-type: none"> 1. hHid = Handle to HID function driver. 2. pSetup = Pointer to setup packet received from host. 3. pBuffer = Pointer to a pointer of data buffer containing report data. Pointer-to-pointer is used to implement zero-copy buffers. See Zero-Copy Data Transfer model for more details on zero-copy concept. 4. length = Amount of data copied to destination buffer. <p>Returns:</p> <p>The call back should returns ErrorCode_t type to indicate success or error condition.</p> <p>Return values:</p> <ol style="list-style-type: none"> 1. LPC_OK = On success. 2. ERR_USBD_UNHANDLED = Event is not handled hence pass the event to next in line. 3. ERR_USBD_xxx = For other error conditions.
HID_GetPhysDesc	<p>ErrorCode_t(* USBD_HID_INIT_PARAM::HID_GetPhysDesc)(USB_HANDLE_T hHid, USB_SETUP_PACKET *pSetup, uint8_t **pBuf, uint16_t *length)</p> <p>Optional callback function to handle HID_GetPhysDesc request.</p> <p>The application software could provide this callback HID_GetPhysDesc handler to handle get physical descriptor requests sent by the host. When host requests Physical Descriptor set 0, application should return a special descriptor identifying the number of descriptor sets and their sizes. A Get_Descriptor request with the Physical Index equal to 1 should return the first Physical Descriptor set. A device could possibly have alternate uses for its items. These can be enumerated by issuing subsequent Get_Descriptor requests while incrementing the Descriptor Index. A device should return the last descriptor set to requests with an index greater than the last number defined in the HID descriptor.</p> <p>Remark: Applications which don't have physical descriptor should set this data member to zero before calling the USBD_HID_API::Init().</p> <p>Parameters:</p> <ol style="list-style-type: none"> 1. hHid = Handle to HID function driver. 2. pSetup = Pointer to setup packet received from host. 3. pBuf = Pointer to a pointer of data buffer containing physical descriptor data. If the physical descriptor is in USB accessible memory area application could just update the pointer or else it should copy the descriptor to the address pointed by this pointer. 4. length = Amount of data copied to destination buffer or descriptor length. <p>Returns:</p> <p>The call back should returns ErrorCode_t type to indicate success or error condition.</p> <p>Return values:</p> <ol style="list-style-type: none"> 1. LPC_OK = On success. 2. ERR_USBD_UNHANDLED = Event is not handled hence pass the event to next in line. 3. ERR_USBD_xxx = For other error conditions.

Table 516. USBD_HID_INIT_PARAM class structure

Member	Description
HID_SetIdle	<p>ErrorCode_t(* USBD_HID_INIT_PARAM::HID_SetIdle)(USB_HANDLE_T hHid, USB_SETUP_PACKET *pSetup, uint8_t idleTime)</p> <p>Optional callback function to handle HID_REQUEST_SET_IDLE request.</p> <p>The application software could provide this callback to handle HID_REQUEST_SET_IDLE requests sent by the host. This callback is provided to applications to adjust timers associated with various reports, which are sent to host over interrupt endpoint. The setup packet data (</p> <p>Remark: Applications which don't send reports on Interrupt endpoint or don't have idle time between reports should set this data member to zero before calling the USBD_HID_API::Init().</p> <p>Parameters:</p> <ol style="list-style-type: none"> 1. hHid = Handle to HID function driver. 2. pSetup = Pointer to setup packet received from host. 3. idleTime = Idle time to be set for the specified report. <p>Returns:</p> <p>The call back should returns ErrorCode_t type to indicate success or error condition.</p> <p>Return values:</p> <ol style="list-style-type: none"> 1. LPC_OK = On success. 2. ERR_USB_UNHANDLED = Event is not handled hence pass the event to next in line. 3. ERR_USB_xxx = For other error conditions.
HID_SetProtocol	<p>ErrorCode_t(* USBD_HID_INIT_PARAM::HID_SetProtocol)(USB_HANDLE_T hHid, USB_SETUP_PACKET *pSetup, uint8_t protocol)</p> <p>Optional callback function to handle HID_REQUEST_SET_PROTOCOL request.</p> <p>The application software could provide this callback to handle HID_REQUEST_SET_PROTOCOL requests sent by the host. This callback is provided to applications to adjust modes of their code between boot mode and report mode.</p> <p>Remark: Applications which don't support protocol modes should set this data member to zero before calling the USBD_HID_API::Init().</p> <p>Parameters:</p> <ol style="list-style-type: none"> 1. hHid = Handle to HID function driver. 2. pSetup = Pointer to setup packet received from host. 3. protocol = Protocol mode. 0 = Boot Protocol 1 = Report Protocol <p>Returns:</p> <p>The call back should returns ErrorCode_t type to indicate success or error condition.</p> <p>Return values:</p> <ol style="list-style-type: none"> 1. LPC_OK = On success. 2. ERR_USB_UNHANDLED = Event is not handled hence pass the event to next in line. 3. ERR_USB_xxx = For other error conditions.

Table 516. USBD_HID_INIT_PARAM class structure

Member	Description
HID_EpIn_Hdlr	<p>ErrorCode_t(* USBD_HID_INIT_PARAM::HID_EpIn_Hdlr)(USB_HANDLE_T hUsb, void *data, uint32_t event)</p> <p>Optional Interrupt IN endpoint event handler.</p> <p>The application software could provide Interrupt IN endpoint event handler. Application which send reports to host on interrupt endpoint should provide an endpoint event handler through this data member. This data member is ignored if the interface descriptor</p> <p>Parameters:</p> <ol style="list-style-type: none"> 1. hUsb = Handle to the USB device stack. 2. data = Handle to HID function driver. 3. event = Type of endpoint event. See USBD_EVENT_T for more details. <p>Returns:</p> <p>The call back should return ErrorCode_t type to indicate success or error condition.</p> <p>Return values:</p> <ol style="list-style-type: none"> 1. LPC_OK = On success. 2. ERR_USBD_UNHANDLED = Event is not handled hence pass the event to next in line. 3. ERR_USBD_xxx = For other error conditions.

Table 516. USBD_HID_INIT_PARAM class structure

Member	Description
HID_EpOut_Hdlr	<p>ErrorCode_t(* USBD_HID_INIT_PARAM::HID_EpOut_Hdlr)(USB_HANDLE_T hUsb, void *data, uint32_t event)</p> <p>Optional Interrupt OUT endpoint event handler.</p> <p>The application software could provide Interrupt OUT endpoint event handler. Application which receives reports from host on interrupt endpoint should provide an endpoint event handler through this data member. This data member is ignored if the interface descriptor</p> <p>Parameters:</p> <ol style="list-style-type: none"> 1. hUsb = Handle to the USB device stack. 2. data = Handle to HID function driver. 3. event = Type of endpoint event. See USBD_EVENT_T for more details. <p>Returns:</p> <p>The call back should return ErrorCode_t type to indicate success or error condition.</p> <p>Return values:</p> <ol style="list-style-type: none"> 1. LPC_OK = On success. 2. ERR_USB_UNHANDLED = Event is not handled hence pass the event to next in line. 3. ERR_USB_xxx = For other error conditions.
HID_GetReportDesc	<p>ErrorCode_t(* USBD_HID_INIT_PARAM::HID_GetReportDesc)(USB_HANDLE_T hHid, USB_SETUP_PACKET *pSetup, uint8_t **pBuf, uint16_t *length)</p> <p>Optional user overridable function to replace the default HID_GetReportDesc handler.</p> <p>The application software could override the default HID_GetReportDesc handler with their own by providing the handler function address as this data member of the parameter structure. Application which like the default handler should set this data member to zero before calling the USBD_HID_API::Init() and also provide report data array</p> <p>Remark:</p> <p>Parameters:</p> <ol style="list-style-type: none"> 1. hUsb = Handle to the USB device stack. 2. data = Pointer to the data which will be passed when callback function is called by the stack. 3. event = Type of endpoint event. See USBD_EVENT_T for more details. <p>Returns:</p> <p>The call back should returns ErrorCode_t type to indicate success or error condition.</p> <p>Return values:</p> <ol style="list-style-type: none"> 1. LPC_OK = On success. 2. ERR_USB_UNHANDLED = Event is not handled hence pass the event to next in line. 3. ERR_USB_xxx = For other error conditions.

Table 516. USBD_HID_INIT_PARAM class structure

Member	Description
HID_Ep0_Hdlr	<p>ErrorCode_t(* USBD_HID_INIT_PARAM::HID_Ep0_Hdlr)(USB_HANDLE_T hUsb, void *data, uint32_t event)</p> <p>Optional user overridable function to replace the default HID class handler.</p> <p>The application software could override the default EP0 class handler with their own by providing the handler function address as this data member of the parameter structure. Application which like the default handler should set this data member to zero before calling the USBD_HID_API::Init().</p> <p>Remark:</p> <p>Parameters:</p> <ol style="list-style-type: none"> 1. hUsb = Handle to the USB device stack. 2. data = Pointer to the data which will be passed when callback function is called by the stack. 3. event = Type of endpoint event. See USBD_EVENT_T for more details. <p>Returns:</p> <p>The call back should returns ErrorCode_t type to indicate success or error condition.</p> <p>Return values:</p> <ol style="list-style-type: none"> 1. LPC_OK = On success. 2. ERR_USBD_UNHANDLED = Event is not handled hence pass the event to next in line. 3. ERR_USBD_xxx = For other error conditions.

25.5.34 USBD_HW_API

Hardware API functions structure. This module exposes functions which interact directly with USB device controller hardware.

Table 517. USBD_HW_API class structure

Member	Description
GetMemSize	<p>uint32_t(*uint32_t USBD_HW_API::GetMemSize)(USB_API_INIT_PARAM_T *param)</p> <p>Function to determine the memory required by the USB device stack's DCD and core layers. This function is called by application layer before calling pUsbApi->hw-></p> <p>Remark: Some memory areas are not accessible by all bus masters.</p> <p>Parameters:</p> <ol style="list-style-type: none"> 1. param = Structure containing USB device stack initialization parameters. <p>Returns:</p> <p>Returns the required memory size in bytes.</p>
Init	<p>ErrorCode_t(*ErrorCode_t USBD_HW_API::Init)(USB_HANDLE_T *phUsb, USB_CORE_DESCS_T *pDesc, USB_API_INIT_PARAM_T *param)</p> <p>Function to initialize USB device stack's DCD and core layers. This function is called by application layer to initialize USB hardware and core layers. On successful initialization the function returns a handle to USB device stack which should be passed to the rest of the functions.</p> <p>Parameters:</p> <ol style="list-style-type: none"> 1. phUsb = Pointer to the USB device stack handle of type USB_HANDLE_T. 2. param = Structure containing USB device stack initialization parameters. <p>Returns:</p> <p>Returns ErrorCode_t type to indicate success or error condition.</p> <p>Return values:</p> <ol style="list-style-type: none"> 1. LPC_OK(0) = On success 2. ERR_USBD_BAD_MEM_BUF(0x0004000b) = When insufficient memory buffer is passed or memory is not aligned on 2048 boundary.
Connect	<p>void(*void USBD_HW_API::Connect)(USB_HANDLE_T hUsb, uint32_t con)</p> <p>Function to make USB device visible/invisible on the USB bus. This function is called after the USB initialization. This function uses the soft connect feature to make the device visible on the USB bus. This function is called only after the application is ready to handle the USB data. The enumeration process is started by the host after the device detection. The driver handles the enumeration process according to the USB descriptors passed in the USB initialization function.</p> <p>Parameters:</p> <ol style="list-style-type: none"> 1. hUsb = Handle to the USB device stack. 2. con = States whether to connect (1) or to disconnect (0). <p>Returns:</p> <p>Nothing.</p>

Table 517. USBD_HW_API class structure

Member	Description
ISR	<p>void(*void USBD_HW_API::ISR)(USBD_HANDLE_T hUsb)</p> <p>Function to USB device controller interrupt events.</p> <p>When the user application is active the interrupt handlers are mapped in the user flash space. The user application must provide an interrupt handler for the USB interrupt and call this function in the interrupt handler routine. The driver interrupt handler takes appropriate action according to the data received on the USB bus.</p> <p>Parameters:</p> <ol style="list-style-type: none"> 1. hUsb = Handle to the USB device stack. <p>Returns:</p> <p>Nothing.</p>
Reset	<p>void(*void USBD_HW_API::Reset)(USBD_HANDLE_T hUsb)</p> <p>Function to Reset USB device stack and hardware controller.</p> <p>Reset USB device stack and hardware controller. Disables all endpoints except EP0. Clears all pending interrupts and resets endpoint transfer queues. This function is called internally by pUsbApi->hw->init() and from reset event.</p> <p>Parameters:</p> <ol style="list-style-type: none"> 1. hUsb = Handle to the USB device stack. <p>Returns:</p> <p>Nothing.</p>
ForceFullSpeed	<p>void(*void USBD_HW_API::ForceFullSpeed)(USBD_HANDLE_T hUsb, uint32_t cfg)</p> <p>Function to force high speed USB device to operate in full speed mode.</p> <p>This function is useful for testing the behavior of current device when connected to a full speed only hosts.</p> <p>Parameters:</p> <ol style="list-style-type: none"> 1. hUsb = Handle to the USB device stack. 2. cfg = When 1 - set force full-speed or 0 - clear force full-speed. <p>Returns:</p> <p>Nothing.</p>

Table 517. USBD_HW_API class structure

Member	Description
WakeUpCfg	<p><code>void(*void USBD_HW_API::WakeUpCfg)(USBD_HANDLE_T hUsb, uint32_t cfg)</code></p> <p>Function to configure USB device controller to walk-up host on remote events.</p> <p>This function is called by application layer to configure the USB device controller to wake up on remote events. It is recommended to call this function from users's <code>USB_WakeUpCfg()</code> callback routine registered with stack.</p> <p>Remark: User's <code>USB_WakeUpCfg()</code> is registered with stack by setting the <code>USB_WakeUpCfg</code> member of <code>USBD_API_INIT_PARAM_T</code> structure before calling <code>pUsbApi->hw->Init()</code> routine. Certain USB device controllers needed to keep some clocks always on to generate resume signaling through <code>pUsbApi->hw->WakeUp()</code>. This hook is provided to support such controllers. In most controllers cases this is an empty routine.</p> <p>Parameters:</p> <ol style="list-style-type: none"> 1. <code>hUsb</code> = Handle to the USB device stack. 2. <code>cfg</code> = When 1 - Configure controller to wake on remote events or 0 - Configure controller not to wake on remote events. <p>Returns:</p> <p>Nothing.</p>
SetAddress	<p><code>void(*void USBD_HW_API::SetAddress)(USBD_HANDLE_T hUsb, uint32_t adr)</code></p> <p>Function to set USB address assigned by host in device controller hardware.</p> <p>This function is called automatically when <code>USB_REQUEST_SET_ADDRESS</code> request is received by the stack from USB host. This interface is provided to users to invoke this function in other scenarios which are not handle by current stack. In most user applications this function is not called directly. Also this function can be used by users who are selectively modifying the USB device stack's standard handlers through callback interface exposed by the stack.</p> <p>Parameters:</p> <ol style="list-style-type: none"> 1. <code>hUsb</code> = Handle to the USB device stack. 2. <code>adr</code> = USB bus Address to which the device controller should respond. Usually assigned by the USB host. <p>Returns:</p> <p>Nothing.</p>
Configure	<p><code>void(*void USBD_HW_API::Configure)(USBD_HANDLE_T hUsb, uint32_t cfg)</code></p> <p>Function to configure device controller hardware with selected configuration.</p> <p>This function is called automatically when <code>USB_REQUEST_SET_CONFIGURATION</code> request is received by the stack from USB host. This interface is provided to users to invoke this function in other scenarios which are not handle by current stack. In most user applications this function is not called directly. Also this function can be used by users who are selectively modifying the USB device stack's standard handlers through callback interface exposed by the stack.</p> <p>Parameters:</p> <ol style="list-style-type: none"> 1. <code>hUsb</code> = Handle to the USB device stack. 2. <code>cfg</code> = Configuration index. <p>Returns:</p> <p>Nothing.</p>

Table 517. USBD_HW_API class structure

Member	Description
ConfigEP	<p><code>void(*void USBD_HW_API::ConfigEP)(USB_HANDLE_T hUsb, USB_ENDPOINT_DESCRIPTOR *pEPD)</code></p> <p>Function to configure USB Endpoint according to descriptor.</p> <p>This function is called automatically when <code>USB_REQUEST_SET_CONFIGURATION</code> request is received by the stack from USB host. All the endpoints associated with the selected configuration are configured. This interface is provided to users to invoke this function in other scenarios which are not handle by current stack. In most user applications this function is not called directly. Also this function can be used by users who are selectively modifying the USB device stack's standard handlers through callback interface exposed by the stack.</p> <p>Parameters:</p> <ol style="list-style-type: none"> 1. <code>hUsb</code> = Handle to the USB device stack. 2. <code>pEPD</code> = Endpoint descriptor structure defined in USB 2.0 specification. <p>Returns:</p> <p>Nothing.</p>
DirCtrlEP	<p><code>void(*void USBD_HW_API::DirCtrlEP)(USB_HANDLE_T hUsb, uint32_t dir)</code></p> <p>Function to set direction for USB control endpoint EP0.</p> <p>This function is called automatically by the stack on need basis. This interface is provided to users to invoke this function in other scenarios which are not handle by current stack. In most user applications this function is not called directly. Also this function can be used by users who are selectively modifying the USB device stack's standard handlers through callback interface exposed by the stack.</p> <p>Parameters:</p> <ol style="list-style-type: none"> 1. <code>hUsb</code> = Handle to the USB device stack. 2. <code>cfg</code> = When 1 - Set EP0 in IN transfer mode 0 - Set EP0 in OUT transfer mode <p>Returns:</p> <p>Nothing.</p>

Table 517. USBD_HW_API class structure

Member	Description
EnableEP	<p>void(*void USBD_HW_API::EnableEP)(USB_HANDLE_T hUsb, uint32_t EPNum)</p> <p>Function to enable selected USB endpoint. This function enables interrupts on selected endpoint.</p> <p>Parameters:</p> <ol style="list-style-type: none"> 1. hUsb = Handle to the USB device stack. 2. EPNum = Endpoint number as per USB specification. ie. An EP1_IN is represented by 0x81 number. <p>Returns:</p> <p>Nothing.</p> <p>This function enables interrupts on selected endpoint.</p> <p>Parameters:</p> <ol style="list-style-type: none"> 1. hUsb = Handle to the USB device stack. 2. EPNum = Endpoint number corresponding to the event as per USB specification. ie. An EP1_IN is represented by 0x81 number. For device events set this param to 0x0. 3. event = Type of endpoint event. See USB_EVENT_T for more details. 4. enable = 1 - enable event, 0 - disable event. <p>Returns:</p> <p>Returns ErrorCode_t type to indicate success or error condition.</p> <p>Return values:</p> <ol style="list-style-type: none"> 1. LPC_OK(0) = - On success 2. ERR_USBD_INVALID_REQ(0x00040001) = - Invalid event type.
DisableEP	<p>void(*void USBD_HW_API::DisableEP)(USB_HANDLE_T hUsb, uint32_t EPNum)</p> <p>Function to disable selected USB endpoint. This function disables interrupts on selected endpoint.</p> <p>Parameters:</p> <ol style="list-style-type: none"> 1. hUsb = Handle to the USB device stack. 2. EPNum = Endpoint number as per USB specification. ie. An EP1_IN is represented by 0x81 number. <p>Returns:</p> <p>Nothing.</p>
ResetEP	<p>void(*void USBD_HW_API::ResetEP)(USB_HANDLE_T hUsb, uint32_t EPNum)</p> <p>Function to reset selected USB endpoint. This function flushes the endpoint buffers and resets data toggle logic.</p> <p>Parameters:</p> <ol style="list-style-type: none"> 1. hUsb = Handle to the USB device stack. 2. EPNum = Endpoint number as per USB specification. ie. An EP1_IN is represented by 0x81 number. <p>Returns:</p> <p>Nothing.</p>

Table 517. USBD_HW_API class structure

Member	Description
SetStallEP	<p>void(*void USBD_HW_API::SetStallEP)(USBD_HANDLE_T hUsb, uint32_t EPNuM)</p> <p>Function to STALL selected USB endpoint. Generates STALL signalling for requested endpoint.</p> <p>Parameters:</p> <ol style="list-style-type: none"> 1. hUsb = Handle to the USB device stack. 2. EPNuM = Endpoint number as per USB specification. ie. An EP1_IN is represented by 0x81 number. <p>Returns:</p> <p>Nothing.</p>
ClrStallEP	<p>void(*void USBD_HW_API::ClrStallEP)(USBD_HANDLE_T hUsb, uint32_t EPNuM)</p> <p>Function to clear STALL state for the requested endpoint. This function clears STALL state for the requested endpoint.</p> <p>Parameters:</p> <ol style="list-style-type: none"> 1. hUsb = Handle to the USB device stack. 2. EPNuM = Endpoint number as per USB specification. ie. An EP1_IN is represented by 0x81 number. <p>Returns:</p> <p>Nothing.</p>
SetTestMode	<p>ErrorCode_t(*ErrorCode_t USBD_HW_API::SetTestMode)(USBD_HANDLE_T hUsb, uint8_t mode)</p> <p>Function to set high speed USB device controller in requested test mode. USB-IF requires the high speed device to be put in various test modes for electrical testing. This USB device stack calls this function whenever it receives USB_REQUEST_CLEAR_FEATURE request for USB_FEATURE_TEST_MODE. Users can put the device in test mode by directly calling this function. Returns ERR_USBD_INVALID_REQ when device controller is full-speed only.</p> <p>Parameters:</p> <ol style="list-style-type: none"> 1. hUsb = Handle to the USB device stack. 2. mode = Test mode defined in USB 2.0 electrical testing specification. <p>Returns:</p> <p>Returns ErrorCode_t type to indicate success or error condition.</p> <p>Return values:</p> <ol style="list-style-type: none"> 1. LPC_OK(0) = - On success 2. ERR_USBD_INVALID_REQ(0x00040001) = - Invalid test mode or Device controller is full-speed only.

Table 517. USBD_HW_API class structure

Member	Description
ReadEP	<p>uint32_t(*uint32_t USBD_HW_API::ReadEP)(USB_HANDLE_T hUsb, uint32_t EPNum, uint8_t *pData)</p> <p>Function to read data received on the requested endpoint.</p> <p>This function is called by USB stack and the application layer to read the data received on the requested endpoint.</p> <p>Parameters:</p> <ol style="list-style-type: none"> 1. hUsb = Handle to the USB device stack. 2. EPNum = Endpoint number as per USB specification. ie. An EP1_IN is represented by 0x81 number. 3. pData = Pointer to the data buffer where data is to be copied. <p>Returns:</p> <p>Returns the number of bytes copied to the buffer.</p>
ReadReqEP	<p>uint32_t(*uint32_t USBD_HW_API::ReadReqEP)(USB_HANDLE_T hUsb, uint32_t EPNum, uint8_t *pData, uint32_t len)</p> <p>Function to queue read request on the specified endpoint.</p> <p>This function is called by USB stack and the application layer to queue a read request on the specified endpoint.</p> <p>Parameters:</p> <ol style="list-style-type: none"> 1. hUsb = Handle to the USB device stack. 2. EPNum = Endpoint number as per USB specification. ie. An EP1_IN is represented by 0x81 number. 3. pData = Pointer to the data buffer where data is to be copied. This buffer address should be accessible by USB DMA master. 4. len = Length of the buffer passed. <p>Returns:</p> <p>Returns the length of the requested buffer.</p>
ReadSetupPkt	<p>uint32_t(*uint32_t USBD_HW_API::ReadSetupPkt)(USB_HANDLE_T hUsb, uint32_t EPNum, uint32_t *pData)</p> <p>Function to read setup packet data received on the requested endpoint.</p> <p>This function is called by USB stack and the application layer to read setup packet data received on the requested endpoint.</p> <p>Parameters:</p> <ol style="list-style-type: none"> 1. hUsb = Handle to the USB device stack. 2. EPNum = Endpoint number as per USB specification. ie. An EP0_IN is represented by 0x80 number. 3. pData = Pointer to the data buffer where data is to be copied. <p>Returns:</p> <p>Returns the number of bytes copied to the buffer.</p>

Table 517. USBD_HW_API class structure

Member	Description
WriteEP	<p>uint32_t(*uint32_t USBD_HW_API::WriteEP)(USB_HANDLE_T hUsb, uint32_t EPNum, uint8_t *pData, uint32_t cnt)</p> <p>Function to write data to be sent on the requested endpoint. This function is called by USB stack and the application layer to send data on the requested endpoint.</p> <p>Parameters:</p> <ol style="list-style-type: none"> 1. hUsb = Handle to the USB device stack. 2. EPNum = Endpoint number as per USB specification. ie. An EP1_IN is represented by 0x81 number. 3. pData = Pointer to the data buffer from where data is to be copied. 4. cnt = Number of bytes to write. <p>Returns:</p> <p>Returns the number of bytes written.</p>
WakeUp	<p>void(*void USBD_HW_API::WakeUp)(USB_HANDLE_T hUsb)</p> <p>Function to generate resume signaling on bus for remote host wake-up. This function is called by application layer to remotely wake up host controller when system is in suspend state. Application should indicate this remote wake up capability by setting USB_CONFIG_REMOTE_WAKEUP in bmAttributes of Configuration Descriptor. Also this routine will generate resume signalling only if host enables USB_FEATURE_REMOTE_WAKEUP by sending SET_FEATURE request before suspending the bus.</p> <p>Parameters:</p> <ol style="list-style-type: none"> 1. hUsb = Handle to the USB device stack. <p>Returns:</p> <p>Nothing.</p>
EnableEvent	<p>ErrorCode_t(* USBD_HW_API::EnableEvent)(USB_HANDLE_T hUsb, uint32_t EPNum, uint32_t event_type, uint32_t enable)</p>

25.5.35 USBD_MSC_API

MSC class API functions structure. This module exposes functions which interact directly with USB device controller hardware.

Table 518. USBD_MSC_API class structure

Member	Description
GetMemSize	<pre>uint32_t(*uint32_t USBD_MSC_API::GetMemSize)(USB_D_MSC_INIT_PARAM_T *param)</pre> <p>Function to determine the memory required by the MSC function driver module.</p> <p>This function is called by application layer before calling pUsbApi->msc->Init(), to allocate memory used by MSC function driver module. The application should allocate the memory which is accessible by USB controller/DMA controller.</p> <p>Remark: Some memory areas are not accessible by all bus masters.</p> <p>Parameters:</p> <ol style="list-style-type: none"> 1. param = Structure containing MSC function driver module initialization parameters. <p>Returns:</p> <p>Returns the required memory size in bytes.</p>
init	<pre>ErrorCode_t(*ErrorCode_t USBD_MSC_API::init)(USB_D_HANDLE_T hUsb, USB_D_MSC_INIT_PARAM_T *param)</pre> <p>Function to initialize MSC function driver module.</p> <p>This function is called by application layer to initialize MSC function driver module.</p> <p>Parameters:</p> <ol style="list-style-type: none"> 1. hUsb = Handle to the USB device stack. 2. param = Structure containing MSC function driver module initialization parameters. <p>Returns:</p> <p>Returns ErrorCode_t type to indicate success or error condition.</p> <p>Return values:</p> <ol style="list-style-type: none"> 1. LPC_OK = On success 2. ERR_USBD_BAD_MEM_BUF = Memory buffer passed is not 4-byte aligned or smaller than required. 3. ERR_API_INVALID_PARAM2 = Either MSC_Write() or MSC_Read() or MSC_Verify() callbacks are not defined. 4. ERR_USBD_BAD_INTF_DESC = Wrong interface descriptor is passed. 5. ERR_USBD_BAD_EP_DESC = Wrong endpoint descriptor is passed.

25.5.36 USBD_MSC_INIT_PARAM

Mass Storage class function driver initialization parameter data structure.

Table 519. USBD_MSC_INIT_PARAM class structure

Member	Description
mem_base	uint32_t USBD_MSC_INIT_PARAM::mem_base Base memory location from where the stack can allocate data and buffers. Remark: The memory address set in this field should be accessible by USB DMA controller. Also this value should be aligned on 4 byte boundary.
mem_size	uint32_t USBD_MSC_INIT_PARAM::mem_size The size of memory buffer which stack can use. Remark: The mem_size should be greater than the size returned by USBD_MSC_API::GetMemSize() routine.
InquiryStr	uint8_t * USBD_MSC_INIT_PARAM::InquiryStr Pointer to the 28 character string. This string is sent in response to the SCSI Inquiry command. Remark: The data pointed by the pointer should be of global scope.
BlockCount	uint32_t USBD_MSC_INIT_PARAM::BlockCount Number of blocks present in the mass storage device
BlockSize	uint32_t USBD_MSC_INIT_PARAM::BlockSize Block size in number of bytes
MemorySize	uint32_t USBD_MSC_INIT_PARAM::MemorySize Memory size in number of bytes
intf_desc	uint8_t * USBD_MSC_INIT_PARAM::intf_desc Pointer to the interface descriptor within the descriptor array (
MSC_Write	void(*void(* USBD_MSC_INIT_PARAM::MSC_Write)(uint32_t offset, uint8_t **src, uint32_t length))(uint32_t offset, uint8_t **src, uint32_t length) MSC Write callback function. This function is provided by the application software. This function gets called when host sends a write command. Parameters: <ol style="list-style-type: none"> 1. offset = Destination start address. 2. src = Pointer to a pointer to the source of data. Pointer-to-pointer is used to implement zero-copy buffers. See Zero-Copy Data Transfer model for more details on zero-copy concept. 3. length = Number of bytes to be written. Returns: Nothing.

Table 519. USBD_MSC_INIT_PARAM class structure

Member	Description
MSC_Read	<pre>void(*void(* USBD_MSC_INIT_PARAM::MSC_Read)(uint32_t offset, uint8_t **dst, uint32_t length))(uint32_t offset, uint8_t **dst, uint32_t length)</pre> <p>MSC Read callback function.</p> <p>This function is provided by the application software. This function gets called when host sends a read command.</p> <p>Parameters:</p> <ol style="list-style-type: none"> 1. offset = Source start address. 2. dst = Pointer to a pointer to the source of data. The MSC function drivers implemented in stack are written with zero-copy model. Meaning the stack doesn't make an extra copy of buffer before writing/reading data from USB hardware FIFO. Hence the parameter is pointer to a pointer containing address buffer (uint8_t** dst). So that the user application can update the buffer pointer instead of copying data to address pointed by the parameter. /note The updated buffer address should be access able by USB DMA master. If user doesn't want to use zero-copy model, then the user should copy data to the address pointed by the passed buffer pointer parameter and shouldn't change the address value. See Zero-Copy Data Transfer model for more details on zero-copy concept. 3. length = Number of bytes to be read. <p>Returns:</p> <p>Nothing.</p>

Table 519. USBD_MSC_INIT_PARAM class structure

Member	Description
MSC_Verify	<p>ErrorCode_t(* USBD_MSC_INIT_PARAM::MSC_Verify)(uint32_t offset, uint8_t buf[], uint32_t length)</p> <p>MSC Verify callback function.</p> <p>This function is provided by the application software. This function gets called when host sends a verify command. The callback function should compare the buffer with the destination memory at the requested offset and</p> <p>Parameters:</p> <ol style="list-style-type: none"> 1. offset = Destination start address. 2. buf = Buffer containing the data sent by the host. 3. length = Number of bytes to verify. <p>Returns:</p> <p>Returns ErrorCode_t type to indicate success or error condition.</p> <p>Return values:</p> <ol style="list-style-type: none"> 1. LPC_OK = If data in the buffer matches the data at destination 2. ERR_FAILED = At least one byte is different.
MSC_GetWriteBuf	<p>void(*void(* USBD_MSC_INIT_PARAM::MSC_GetWriteBuf)(uint32_t offset, uint8_t **buff_adr, uint32_t length))(uint32_t offset, uint8_t **buff_adr, uint32_t length)</p> <p>Optional callback function to optimize MSC_Write buffer transfer.</p> <p>This function is provided by the application software. This function gets called when host sends SCSI_WRITE10/SCSI_WRITE12 command. The callback function should update the</p> <p>Parameters:</p> <ol style="list-style-type: none"> 1. offset = Destination start address. 2. buf = Buffer containing the data sent by the host. 3. length = Number of bytes to write. <p>Returns:</p> <p>Nothing.</p>

Table 519. USBD_MSC_INIT_PARAM class structure

Member	Description
MSC_Ep0_Hdlr	<p>ErrorCode_t(* USBD_MSC_INIT_PARAM::MSC_Ep0_Hdlr)(USB_HANDLE_T hUsb, void *data, uint32_t event)</p> <p>Optional user overridable function to replace the default MSC class handler.</p> <p>The application software could override the default EP0 class handler with their own by providing the handler function address as this data member of the parameter structure. Application which like the default handler should set this data member to zero before calling the USBD_MSC_API::Init().</p> <p>Remark:</p> <p>Parameters:</p> <ol style="list-style-type: none"> 1. hUsb = Handle to the USB device stack. 2. data = Pointer to the data which will be passed when callback function is called by the stack. 3. event = Type of endpoint event. See USBD_EVENT_T for more details. <p>Returns:</p> <p>The call back should returns ErrorCode_t type to indicate success or error condition.</p> <p>Return values:</p> <ol style="list-style-type: none"> 1. LPC_OK = On success. 2. ERR_USBD_UNHANDLED = Event is not handled hence pass the event to next in line. 3. ERR_USBD_xxx = For other error conditions.

25.5.37 USB API error codes

For general error codes, see [Chapter 48 “LPC18xx API General error codes”](#).

26.1 How to read this chapter

The Ethernet controller is available on parts LPC185x and LPC183x.

The MII is not available on the LQFP144 and TFBGA100 packages.

26.2 Basic configuration

The Ethernet controller is configured as follows:

- See [Table 520](#) for clocking and power control.
- The Ethernet is reset by the ETHERNET_RST (reset # 22).
- The Ethernet interrupt is connected to interrupt slot # 5 in the NVIC.
- The Ethernet wake-up packet indicator is connected to slot # 8 in the event router.
- Set the Ethernet mode to RMI or MII in the CREG6 register in the CREG block (see [Table 96](#)).

Table 520. Ethernet clocking and power control

	Base clock	Branch clock	Operating frequency	Notes
Ethernet register interface clock	BASE_M3_CLK	CLK_M3_ETHERNET	up to 180 MHz	-

26.3 Features

- 10/100 Mbit/s
- DMA support
- IEEE 1588 time stamping block
- IEEE 1588 advanced time stamp support (IEEE 1588-2008 v2)
- Power management remote wake-up frame and magic packet detection
- Supports both full-duplex and half-duplex operation
 - Supports CSMA/CD Protocol for half-duplex operation.
 - Supports IEEE 802.3x flow control for full-duplex operation.
 - Optional forwarding of received pause control frames to the user application in full-duplex operation.
 - Back-pressure support for half-duplex operation.
 - Automatic transmission of zero-quanta pause frame on deassertion of flow control input in full-duplex operation.

26.4 General description

The Ethernet block enables a host to transmit and receive data over Ethernet in compliance with the IEEE 802.3-2005 standard. The Ethernet interface contains a full featured 10 Mbps or 100 Mbps Ethernet MAC (Media Access Controller) designed to provide optimized performance through the use of DMA hardware acceleration.

Features include a generous suite of control registers, half or full duplex operation, flow control, control frames, hardware acceleration for transmit retry, receive packet filtering and wake-up on LAN activity, supporting both Wake-Up and Magic Packet frames. Automatic frame transmission and reception with Scatter-Gather DMA off-loads many operations from the CPU.

Additional features such as IEEE 1588 Time Stamping (IEEE 1588-2002) and IEEE Advanced Time Stamp support (IEEE 1588-2008 v2) enrich the list of supported features.

The Ethernet block is an AHB master connected to the AHB Multilayer Matrix and has access to internal SRAM and memory connected to the External Memory Controller for Ethernet data, control, and status information. Other AHB traffic in the LPC18xx can take place using other masters, effectively separating Ethernet activity from the rest of the system.

The Ethernet block interfaces with an off-chip Ethernet PHY using the MII (Media Independent Interface) or RMII (reduced MII) protocol and with the on-chip MIIM (Media Independent Interface Management) serial bus.

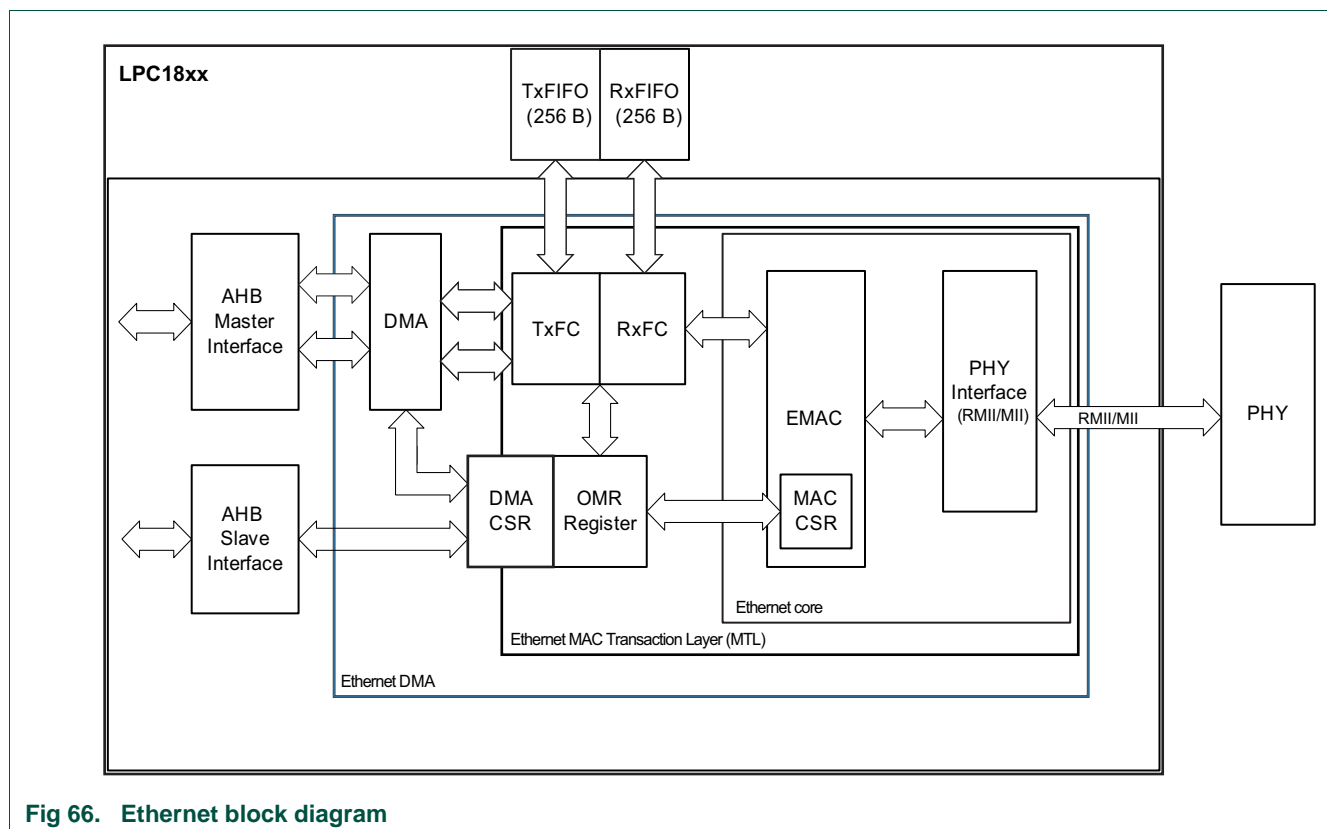

Fig 66. Ethernet block diagram

26.5 Pin description

Table 521. Ethernet pin description

Pin function	Direction	Description
MIIM interface		
ENET_MDIO	I/O	Ethernet MIIM Data Input and Output.
ENET_MDC	O	Ethernet MIIM Clock.
RMI interface		
ENET_RXD[1:0]	I	Ethernet Receive Data.
ENET_TXD[1:0]	O	Ethernet Transmit Data.
ENET_RX_DV	I	Ethernet Receive Data Valid.
ENET_REF_CLK	I	Ethernet Reference Clock.
ENET_TX_EN	O	Ethernet Transmit Data Enable.
MII interface		
ENET_RXD[3:0]	I	Ethernet Receive Data.
ENET_TXD[3:0]	O	Ethernet Transmit Data.
ENET_COL	I	Ethernet Collision detect.
ENET_CRD	I	Ethernet Carrier Sense.
ENET_TX_ER	O	Ethernet Transmit Error.
ENET_TX_CLK	I	Ethernet Transmit Clock.
ENET_RX_CLK	I	Ethernet Receive Clock.
ENET_RX_ER	I	Ethernet Receive Error.
ENET_TX_EN	O	Ethernet Transmit Enable.

26.6 Register description

Table 522. Register overview: Ethernet MAC and DMA (base address 0x4001 0000)

Name	Access	Address offset	Description	Reset value	Reference
MAC_CONFIG	R/W	0x0000	MAC configuration register	0x0000 8000	Table 523
MAC_FRAME_FILTER	R/W	0x0004	MAC frame filter	0x0000 0000	Table 524
MAC_HASHTABLE_HIGH	R/W	0x0008	Hash table high register	0x0000 0000	Table 525
MAC_HASHTABLE_LOW	R/W	0x000C	Hash table low register	0x0000 0000	Table 526
MAC_MII_ADDR	R/W	0x0010	MII address register	0x0000 0000	Table 527
MAC_MII_DATA	R/W	0x0014	MII data register	0x0000 0000	Table 529
MAC_FLOW_CTRL	R/W	0x0018	Flow control register	0x0000 0000	Table 530
MAC_VLAN_TAG	R/W	0x001C	VLAN tag register	0x0000 0000	Table 531
-	-	0x0020	Reserved	-	-
MAC_DEBUG	RO	0x0024	Debug register	0x0000 0000	Table 532
MAC_RWAKE_FRFLT	R/W	0x0028	Remote wake-up frame filter	0x0000 0000	Table 533
MAC_PMT_CTRL_STAT	R/W	0x002C	PMT control and status	0x0000 0000	Table 534
-	-	0x0030 - 0x0034	Reserved	-	-
MAC_INTR	RO	0x0038	Interrupt status register	0x0000 0000	Table 535
MAC_INTR_MASK	R/W	0x003C	Interrupt mask register	0x0000 0000	Table 536
MAC_ADDR0_HIGH	R/W	0x0040	MAC address 0 high register	0x8000 FFFF	Table 537
MAC_ADDR0_LOW	R/W	0x0044	MAC address 0 low register	0xFFFF FFFF	Table 538
-	-	0x0048 - 0x006FC	Reserved	-	-
MAC_TIMESTP_CTRL	R/W	0x0700	Time stamp control register	0x0000 2000	Table 539
SUBSECOND_INCR	R/W	0x0704	Sub-second increment register	0x0000 0000	Table 541
SECONDS	RO	0x0708	System time seconds register	0x0000 0000	Table 542
NANOSECONDS	RO	0x070C	System time nanoseconds register	0x0000 0000	Table 543
SECONDSUPDATE	R/W	0x0710	System time seconds update register	0x0000 0000	Table 544
NANOSECONDSUPDATE	R/W	0x0714	System time nanoseconds update register	0x0000 0000	Table 545
ADDEND	R/W	0x0718	Time stamp addend register	0x0000 0000	Table 546
TARGETSECONDS	R/W	0x071C	Target time seconds register	0x0000 0000	Table 547
TARGETNANOSECONDS	R/W	0x0720	Target time nanoseconds register	0x0000 0000	Table 548
HIGHWORD	R/W	0x0724	System time higher word seconds register	0x0000 0000	Table 549
TIMESTAMPSTAT	RO	0x0728	Time stamp status register	0x0000 0000	Table 550
-	-	0x072C - 0x0FFC	Reserved	-	-
DMA_BUS_MODE	R/W	0x1000	Bus Mode Register	0x0002 0100	Table 551

Table 522. Register overview: Ethernet MAC and DMA (base address 0x4001 0000)

Name	Access	Address offset	Description	Reset value	Reference
DMA_TRANS_POLL_DEMAND	R/W	0x1004	Transmit poll demand register	0x0000 0000	Table 553
DMA_REC_POLL_DEMAND	R/W	0x1008	Receive poll demand register	0x0000 0000	Table 554
DMA_REC_DES_ADDR	R/W	0x100C	Receive descriptor list address register	0x0000 0000	Table 555
DMA_TRANS_DES_ADDR	R/W	0x1010	Transmit descriptor list address register	0x0000 0000	Table 556
DMA_STAT	R/W	0x1014	Status register	0x0000 0000	Table 557
DMA_OP_MODE	R/W	0x1018	Operation mode register	0x0000 0000	Table 558
DMA_INT_EN	R/W	0x101C	Interrupt enable register	0x0000 0000	Table 559
DMA_MFRM_BUFOF	RO	0x1020	Missed frame and buffer overflow register	0x0000 0000	Table 560
DMA_REC_INT_WDT	R/W	0x1024	Receive interrupt watchdog timer register	0x0000 0000	Table 561
-	-	0x1028 - 0x1044	Reserved	-	-
DMA_CURHOST_TRANS_DES	RO	0x1048	Current host transmit descriptor register	0x0000 0000	Table 562
DMA_CURHOST_REC_DES	RO	0x104C	Current host receive descriptor register	0x0000 0000	Table 563
DMA_CURHOST_TRANS_BUF	RO	0x1050	Current host transmit buffer address register	0x0000 0000	Table 564
DMA_CURHOST_REC_BUF	RO	0x1054	Current host receive buffer address register	0x0000 0000	Table 565
-	-	0x1058	-	-	-

26.6.1 MAC Configuration register

The MAC Configuration register establishes receive and transmit operating modes.

Table 523. MAC Configuration register (MAC_CONFIG, address 0x4001 0000) bit description

Bit	Symbol	Description	Reset value	Access
1:0	-	Reserved	00	RO
2	RE	Receiver enable When this bit is set, the receiver state machine of the MAC is enabled for receiving frames from the MII. When this bit is reset, the MAC receive state machine is disabled after the completion of the reception of the current frame, and will not receive any further frames from the MII.	0	R/W
3	TE	Transmitter Enable When this bit is set, the transmit state machine of the MAC is enabled for transmission on the MII. When this bit is reset, the MAC transmit state machine is disabled after the completion of the transmission of the current frame, and will not transmit any further frames.	0	R/W

Table 523. MAC Configuration register (MAC_CONFIG, address 0x4001 0000) bit description ...continued

Bit	Symbol	Description	Reset value	Access
4	DF	<p>Deferral Check</p> <p>When this bit is set, the deferral check function is enabled in the MAC. The MAC will issue a Frame Abort status, along with the excessive deferral error bit set in the transmit frame status when the transmit state machine is deferred for more than 24,288 bit times in 10/100-Mbps mode. If the Core is configured for 1000 Mbps operation, or if the Jumbo frame mode is enabled in 10/100-Mbps mode, the threshold for deferral is 155,680 bits times. Deferral begins when the transmitter is ready to transmit, but is prevented because of an active CRS (carrier sense) signal on the MII. Deferral time is not cumulative. If the transmitter defers for 10,000 bit times, then transmits, collides, backs off, and then has to defer again after completion of back-off, the deferral timer resets to 0 and restarts.</p> <p>When this bit is reset, the deferral check function is disabled and the MAC defers until the CRS signal goes inactive. This bit is applicable only in Half-Duplex mode and is reserved (RO) in Full-Duplex-only configuration.</p>	0	R/W
6:5	BL	<p>Back-Off Limit</p> <p>The Back-Off limit determines the random integer number (r) of slot time delays (4,096 bit times for 1000 Mbps and 512 bit times for 10/100 Mbps) the MAC waits before rescheduling a transmission attempt during retries after a collision. This bit is applicable only to Half-Duplex mode and is reserved (RO) in Full-Duplex-only configuration.</p> <ul style="list-style-type: none"> • 00: $k = \min(n, 10)$ • 01: $k = \min(n, 8)$ • 10: $k = \min(n, 4)$ • 11: $k = \min(n, 1)$ <p>where $n =$ retransmission attempt. The random integer r takes the value in the range $0 \leq r \leq 2^k$.</p>	0	R/W
7	ACS	<p>Automatic Pad/CRC Stripping</p> <p>When this bit is set, the MAC strips the Pad/FCS field on incoming frames only if the length's field value is less than or equal to 1,500 bytes. All received frames with length field greater than or equal to 1,501 bytes are passed to the application without stripping the Pad/FCS field.</p> <p>When this bit is reset, the MAC will pass all incoming frames to the Host unmodified.</p>	0	R/W
8	-	<p>Link Up/Down</p> <p>Indicates whether the link is up or down during the transmission of configuration in SMII interface:</p> <p>0 = Link down 1 = Link up</p>	0	R/W
9	DR	<p>Disable Retry</p> <p>When this bit is set, the MAC will attempt only 1 transmission. When a collision occurs on the MII, the MAC will ignore the current frame transmission and report a Frame Abort with excessive collision error in the transmit frame status.</p> <p>When this bit is reset, the MAC will attempt retries based on the settings of BL. This bit is applicable only to Half-Duplex mode and is reserved (RO with default value) in Full-Duplex-only configuration.</p>	0	R/W
10	-	Reserved	0	RO

Table 523. MAC Configuration register (MAC_CONFIG, address 0x4001 0000) bit description ...continued

Bit	Symbol	Description	Reset value	Access
11	DM	Duplex Mode When this bit is set, the MAC operates in a Full-Duplex mode where it can transmit and receive simultaneously.	0	R/W
12	LM	Loopback Mode When this bit is set, the MAC operates in loopback mode at MII. The MII Receive clock input is required for the loopback to work properly, as the Transmit clock is not looped-back internally.	0	R/W
13	DO	Disable Receive Own When this bit is set, the MAC disables the reception of frames in Half-Duplex mode. When this bit is reset, the MAC receives all packets that are given by the PHY while transmitting. This bit is not applicable if the MAC is operating in Full-Duplex mode.	0	R/W
14	FES	Speed Indicates the speed in Fast Ethernet (MII) mode: 0 = 10 Mbps 1 = 100 Mbps	0	
15	PS	Port select 1 = MII (100 Mbp) - this is the only allowed value.	1	RO
16	DCRS	Disable carrier sense during transmission When set high, this bit makes the MAC transmitter ignore the MII CRS signal during frame transmission in Half-Duplex mode. This request results in no errors generated due to Loss of Carrier or No Carrier during such transmission. When this bit is low, the MAC transmitter generates such errors due to Carrier Sense and will even abort the transmissions.	0	R/W
19:17	IFG	Inter-frame gap These bits control the minimum IFG between frames during transmission. 000 = 96 bit times 001 = 88 bit times 010 = 80 bit times ... 000 = 40 bit times Note that in Half-Duplex mode, the minimum IFG can be configured for 64 bit times (IFG = 100) only. Lower values are not considered	000	R/W
20	JE	Jumbo Frame Enable When this bit is set, MAC allows Jumbo frames of 9,018 bytes (9,022 bytes for VLAN tagged frames) without reporting a giant frame error in the receive frame status.	0	R/W
21	-	Reserved.	0	RO

Table 523. MAC Configuration register (MAC_CONFIG, address 0x4001 0000) bit description ...continued

Bit	Symbol	Description	Reset value	Access
22	JD	Jabber Disable When this bit is set, the MAC disables the jabber timer on the transmitter, and can transfer frames of up to 16,384 bytes. When this bit is reset, the MAC cuts off the transmitter if the application sends out more than 2,048 bytes of data (10,240 if JE is set high) during transmission.	0	R/W
23	WD	Watchdog Disable When this bit is set, the MAC disables the watchdog timer on the receiver, and can receive frames of up to 16,384 bytes. When this bit is reset, the MAC allows no more than 2,048 bytes (10,240 if JE is set high) of the frame being received and cuts off any bytes received after that.	0	R/W
31:24	-	Reserved.	0x00	RO

26.6.2 MAC Frame filter register

The MAC Frame Filter register contains the filter controls for receiving frames. Some of the controls from this register go to the address check block of the MAC, which performs the first level of address filtering. The second level of filtering is performed on the incoming frame, based on other controls such as Pass Bad Frames and Pass Control Frames.

If the hash table filter is enabled for unicast or multicast, then the perfect filter is disabled unless bit 10 is set in this register.

See [Section 26.7.1](#) for examples of how to configure the hash filter.

Table 524. MAC Frame filter register (MAC_FRAME_FILTER, address 0x4001 0004) bit description

Bit	Symbol	Description	Reset value	Access
0	PR	Promiscuous Mode When this bit is set, the Address Filter module passes all incoming frames regardless of its destination or source address. The SA/DA Filter Fails status bits of the Receive Status Word will always be cleared when PR is set.	0	R/W
1	HUC	Hash Unicast When set, MAC performs destination address filtering of unicast frames according to the hash table. When reset, the MAC performs a perfect destination address filtering for unicast frames, that is, it compares the DA field with the values programmed in DA registers.	0	R/W
2	HMC	Hash Multicast When set, MAC performs destination address filtering of received multicast frames according to the hash table. When reset, the MAC performs a perfect destination address filtering for multicast frames, that is, it compares the DA field with the values programmed in DA registers.	0	R/W
3	DAIF	DA Inverse Filtering When this bit is set, the Address Check block operates in inverse filtering mode for the DA address comparison for both unicast and multicast frames. When reset, normal filtering of frames is performed.	0	R/W

Table 524. MAC Frame filter register (MAC_FRAME_FILTER, address 0x4001 0004) bit description ...continued

Bit	Symbol	Description	Reset value	Access
4	PM	Pass All Multicast When set, this bit indicates that all received frames with a multicast destination address (first bit in the destination address field is '1') are passed. When reset, filtering of multicast frame depends on HMC bit.	0	R/W
5	DBF	Disable Broadcast Frames When this bit is set, the AFM module filters all incoming broadcast frames. When this bit is reset, the AFM module passes all received broadcast frames.	0	R/W
7:6	PCF	Pass Control Frames These bits control the forwarding of all control frames (including unicast and multicast PAUSE frames). Note that the processing of PAUSE control frames depends only on RFE of the Flow Control Register. 00 = MAC filters all control frames from reaching the application. 01 = MAC forwards all control frames except PAUSE control frames to application even if they fail the Address filter. 10 = MAC forwards all control frames to application even if they fail the Address Filter. 11 = MAC forwards control frames that pass the Address Filter.	00	R/W
8	-	Reserved.	-	-
9	-	Reserved.	-	-
10	HPF	Hash or perfect filter When set, this bit configures the address filter to pass a frame if it matches either the perfect filtering or the hash filtering as set by HMC or HUC bits. When low and if the HUC/HMC bit is set, the frame is passed only if it matches the Hash filter.	0	R/W
30:11	-	Reserved	0	RO
31	RA	Receive all When this bit is set, the MAC Receiver module passes to the Application all frames received irrespective of whether they pass the address filter. The result of the SA/DA filtering is updated (pass or fail) in the corresponding bits in the Receive Status Word. When this bit is reset, the Receiver module passes to the Application only those frames that pass the SA/DA address filter.	0	R/W

26.6.3 MAC Hash table high register

The 64-bit Hash table is used for group address filtering. For hash filtering, the contents of the destination address in the incoming frame is passed through the CRC logic, and the upper 6 bits of the CRC register are used to index the contents of the Hash table. The most significant bit determines the register to be used (Hash Table High/Hash Table Low), and the other 5 bits determine which bit within the register. A hash value of 00000 selects Bit 0 of the selected register, and a value of 11111 selects Bit 31 of the selected register.

For example, if the DA of the incoming frame is received as 0x1F52419CB6AF (0x1F is the first byte received on MII interface), then the internally calculated 6-bit Hash value is 0x2C and the HTH register bit[12] is checked for filtering. If the DA of the incoming frame is received as 0xA00A98000045, then the calculated 6-bit Hash value is 0x07 and the HTL register bit[7] is checked for filtering.

If the corresponding bit value of the register is 1, the frame is accepted. Otherwise, it is rejected. If the PM (Pass All Multicast) bit is set in the MAC_CONFIG register, then all multicast frames are accepted regardless of the multicast hash values.

If the Hash Table register is configured to be double-synchronized to the MII clock domain, the synchronization is triggered only when Bits[31:24] (in Little-Endian mode) or Bits[7:0] (in Big-Endian mode) of the Hash Table High/Low registers are written to. Please note that consecutive writes to these register should be performed only after at least 4 clock cycles in the destination clock domain when double synchronization is enabled.

The Hash Table High register contains the higher 32 bits of the Hash table.

See [Section 26.7.1](#) for examples of how to configure the hash filter.

Table 525. MAC Hash table high register (MAC_HASHTABLE_HIGH, address 0x4001 0008) bit description

Bit	Symbol	Description	Reset value	Access
31:0	HTH	Hash table high This field contains the upper 32 bits of Hash table.	0	R/W

26.6.4 MAC Hash table low register

The Hash Table Low register contains the lower 32 bits of the Hash table.

See [Section 26.7.1](#) for examples of how to configure the hash filter.

Table 526. MAC Hash table low register (MAC_HASHTABLE_LOW, address 0x4001 0008) bit description

Bit	Symbol	Description	Reset value	Access
31:0	HTL	Hash table low This field contains the upper 32 bits of Hash table.	0	R/W

26.6.5 MAC MII Address register

The MII Address register controls the management cycles to the external PHY through the management interface.

Table 527. MAC MII Address register (MAC_MII_ADDR, address 0x4001 0010) bit description

Bit	Symbol	Description	Reset value	Access
0	GB	<p>MII busy</p> <p>This register field can be read by the application (Read), can be set to 1 by the application with a register write of 1 (Write Set), and is cleared to 0 by the core (Self Clear). The application cannot clear this type of field, and a register write of 0 to this bit has no effect on this field.</p> <p>This bit should read a logic 0 before writing to this register and the MAC_MII_DATA register. This bit must also be set to 0 during a Write to this register. During a PHY register access, this bit will be set to 1 by the Application to indicate that a Read or Write access is in progress. The MAC_MII_DATA register should be kept valid until this bit is cleared by the MAC during a PHY Write operation. The MAC_MII_DATA register is invalid until this bit is cleared by the MAC during a PHY Read operation. This register should not be written to until this bit is cleared.</p>	0	R/W
1	W	<p>MII write</p> <p>When set, this bit tells the PHY that this will be a Write operation using the MII Data register. If this bit is not set, this will be a Read operation, placing the data in the MII Data register.</p>	0	R/W
5:2	CR	<p>CSR clock range</p> <p>The CSR Clock Range selection determines the frequency of the MDC clock. The suggested range of CLK_M3_ETHERNET frequency applicable for each value below (when Bit[5] = 0) ensures that the MDC clock is approximately between the frequency range 1.0 MHz - 2.5 MHz.</p> <p>When bit 5 is set, you can achieve MDC clock of frequency higher than the IEEE 802.3 specified frequency limit of 2.5 MHz and program a clock divider of lower value. For example, when CLK_M3_ETHERNET is of frequency 100 MHz and you program these bits as 1010, then the resultant MDC clock will be of 12.5 MHz which is outside the limit of IEEE 802.3 specified range. Program the values given below only if the interfacing chips supports faster MDC clocks.</p> <p>See Table 528 for bit values.</p>	0	R/W
10:6	GR	<p>MII register</p> <p>These bits select the desired MII register in the selected PHY device.</p>	0	R/W
15:11	PA	<p>Physical layer address</p> <p>This field tells which of the 32 possible PHY devices are being accessed.</p>	0	R/W
31:16	-	Reserved	0	RO

Table 528. CSR clock range values

Bits 5:2	CLK_M3_ETHERNET	MDC clock
0000	60 - 100 MHz	CLK_M3_ETHERNET/42
0001	100 - 150 MHz	CLK_M3_ETHERNET/62
0010	20 - 35 MHz	CLK_M3_ETHERNET/16
0011	35 - 60 MHz	CLK_M3_ETHERNET/26
0100	150 - 250 MHz	CLK_M3_ETHERNET/102
0101	250 - 300 MHz	CLK_M3_ETHERNET/124
0110, 0111	Reserved	-
1000	-	CLK_M3_ETHERNET/42
1001	-	CLK_M3_ETHERNET/62

Table 528. CSR clock range values

Bits 5:2	CLK_M3_ETHERNET	MDC clock
1010	-	CLK_M3_ETHERNET/16
1011	-	CLK_M3_ETHERNET/26
1100	-	CLK_M3_ETHERNET/102
1101	-	CLK_M3_ETHERNET/124
1110	-	CLK_M3_ETHERNET/42
1111	-	CLK_M3_ETHERNET/62

26.6.6 MAC MII Data register

The MII Data register stores Write data to be written to the PHY register located at the address specified in the MAC_MII_ADDR register. This register also stores Read data from the PHY register located at the address specified by the MAC_MII_ADDR register.

Table 529. MII Data register (MAC_MII_DATA, address 0x4001 0014) bit description

Bit	Symbol	Description	Reset value	Access
15:0	GD	MII data This contains the 16-bit data value read from the PHY after a Management Read operation or the 16-bit data value to be written to the PHY before a Management Write operation.	0	R/W
31:16	-	Reserved	0	RO

26.6.7 MAC Flow control register

The Flow Control register controls the generation and reception of the Control (Pause Command) frames by the MAC's Flow control module. A Write to a register with the Busy bit set to 1 triggers the Flow Control block to generate a Pause Control frame. The fields of the control frame are selected as specified in the 802.3x specification, and the Pause Time value from this register is used in the Pause Time field of the control frame. The Busy bit remains set until the control frame is transferred onto the cable. The Host must make sure that the Busy bit is cleared before writing to the register.

Table 530. MAC Flow control register (MAC_FLOW_CTRL, address 0x4001 0018) bit description

Bit	Symbol	Description	Reset value	Access
0	FCB	<p>Flow Control Busy/Backpressure Activate</p> <p>This register field can be read by the application (Read), can be set to 1 by the application with a register write of 1 (Write Set), and is cleared to 0 by the core (Self Clear). The application cannot clear this type of field, and a register write of 0 to this bit has no effect on this field.</p> <p>This bit initiates a Pause Control frame in Full-Duplex mode.</p> <p>In Full-Duplex mode, this bit should be read as 0 before writing to the Flow Control register. To initiate a Pause control frame, the Application must set this bit to 1. During a transfer of the Control Frame, this bit will continue to be set to signify that a frame transmission is in progress. After the completion of Pause control frame transmission, the MAC will reset this bit to 0. The Flow Control register should not be written to until this bit is cleared.</p> <p>In Half-Duplex mode, when this bit is set (and TFE is set), then backpressure is asserted by the MAC Core. During backpressure, when the MAC receives a new frame, the transmitter starts sending a JAM pattern resulting in a collision. This control register bit is logically ORed with the flow controller input signal for the backpressure function. When the MAC is configured to Full- Duplex mode, the BPA is automatically disabled.</p>	0	R/W
1	TFE	<p>Transmit Flow Control Enable</p> <p>In Full-Duplex mode, when this bit is set, the MAC enables the flow control operation to transmit Pause frames. When this bit is reset, the flow control operation in the MAC is disabled, and the MAC will not transmit any Pause frames.</p> <p>In Half-Duplex mode, when this bit is set, the MAC enables the back-pressure operation. When this bit is reset, the backpressure feature is disabled.</p>	0	R/W
2	RFE	<p>Receive Flow Control Enable</p> <p>When this bit is set, the MAC will decode the received Pause frame and disable its transmitter for a specified (Pause Time) time. When this bit is reset, the decode function of the Pause frame is disabled.</p>	0	R/W
3	UP	<p>Unicast Pause Frame Detect</p> <p>When this bit is set, the MAC will detect the Pause frames with the station's unicast address specified in MAC Address0 High Register and MAC Address0 Low Register, in addition to the detecting Pause frames with the unique multicast address. When this bit is reset, the MAC will detect only a Pause frame with the unique multicast address specified in the 802.3x standard.</p>	0	R/W
5:4	PLT	<p>Pause Low Threshold</p> <p>This field configures the threshold of the PAUSE timer at which the input flow control is checked for automatic retransmission of PAUSE Frame. The threshold values should be always less than the Pause Time configured in Bits[31:16]. For example, if PT = 0x100 (256 slot-times), and PLT = 01, then a second PAUSE frame is automatically transmitted if the flow control signal is asserted at 228 (256 – 28) slot-times after the first PAUSE frame is transmitted.</p>	00	R/W
6	-	Reserved	0x000	RO

Table 530. MAC Flow control register (MAC_FLOW_CTRL, address 0x4001 0018) bit description ...continued

Bit	Symbol	Description	Reset value	Access
7	DZPQ	Disable Zero-Quanta Pause When set, this bit disables the automatic generation of Zero-Quanta Pause Control frames on the deassertion of the flow-control signal from the FIFO layer. When this bit is reset, normal operation with automatic Zero-Quanta Pause Control frame generation is enabled.	0	R/W
15:8	-	Reserved	0	RO
31:16	PT	Pause time This field holds the value to be used in the Pause Time field in the transmit control frame. If the Pause Time bits is configured to be double-synchronized to the MII clock domain, then consecutive writes to this register should be performed only after at least 4 clock cycles in the destination clock domain.	0x000 0	R/W

26.6.8 MAC VLAN tag register

The VLAN Tag register contains the IEEE 802.1Q VLAN Tag to identify the VLAN frames. The MAC compares the 13th and 14th bytes of the receiving frame (Length/Type) with 0x8100, and the following 2 bytes are compared with the VLAN tag; if a match occurs, it sets the received VLAN bit in the receive frame status. The legal length of the frame is increased from 1518 bytes to 1522 bytes.

If the VLAN Tag register is configured to be double-synchronized to the MII clock domain, then consecutive writes to these register should be performed only after at least 4 clock cycles in the destination clock domain.

Table 531. MAC VLAN tag register (MAC_VLAN_TAG, address 0x4001 01C) bit description

Bit	Symbol	Description	Reset value	Access
15:0	VL	VLAN Tag Identifier for Receive Frames This contains the 802.1Q VLAN tag to identify VLAN frames, and is compared to the fifteenth and sixteenth bytes of the frames being received for VLAN frames. Bits[15:13] are the User Priority, Bit[12] is the Canonical Format Indicator (CFI) and bits[11:0] are the VLAN tag's VLAN Identifier (VID) field. When the ETV bit is set, only the VID (Bits[11:0]) is used for comparison. If VL (VL[11:0] if ETV is set) is all zeros, the MAC does not check the fifteenth and sixteenth bytes for VLAN tag comparison, and declares all frames with a Type field value of 0x8100 to be VLAN frames.	0x000 0	R/W
16	ETV	Enable 12-Bit VLAN Tag Comparison When this bit is set, a 12-bit VLAN identifier, rather than the complete 16-bit VLAN tag, is used for comparison and filtering. Bits[11:0] of the VLAN tag are compared with the corresponding field in the received VLAN-tagged frame. When this bit is reset, all 16 bits of the received VLAN frame's fifteenth and sixteenth bytes are used for comparison.	0	R/W
31:17	-	Reserved	0x000 0	RO

26.6.9 MAC Debug register

This debug register gives the status of all the main modules of the transmit and receive data-paths and the FIFOs. An all-zero status indicates that the MAC core is in idle state (and FIFOs are empty) and no activity is going on in the data-paths.

Remark: Reset values in this register are valid only if the clocks to the Ethernet block are present during the reset operation.

Table 532. MAC Debug register (MAC_DEBUG, address 0x4001 0024) bit description

Bit	Symbol	Description	Reset value	Access
0	RXIDLESTAT	When high, it indicates that the MAC MII receive protocol engine is actively receiving data and not in IDLE state.	0	RO
2:1	FIFOSTAT0	When high, it indicates the active state of the small FIFO Read and Write controllers respectively of the MAC receive Frame Controller module.	0	RO
3	-	Reserved	-	RO
4	RXFIFOSTAT1	When high, it indicates that the MTL RxFIFO Write Controller is active and transferring a received frame to the FIFO.	0	RO
6:5	RXFIFOSTAT	State of the RxFIFO read Controller: 00 = idle state 01 = reading frame data 10 = reading frame status (or time stamp) 11 = flushing the frame data and status	0	RO
7	-	Reserved	-	RO
9:8	RXFIFOLVL	Status of the RxFIFO Fill-level 00 = RxFIFO Empty 01 = RxFIFO fill-level below flow-control de-activate threshold 10 = RxFIFO fill-level above flow-control activate threshold 11 = RxFIFO Full	0	RO
15:10	-	Reserved	-	RO
16	TXIDLESTAT	When high, it indicates that the MAC MII transmit protocol engine is actively transmitting data and not in IDLE state.	0	RO
18:17	TXSTAT	State of the MAC Transmit Frame Controller module: 00 = idle 01 = Waiting for Status of previous frame or IFG/backoff period to be over 10 = Generating and transmitting a PAUSE control frame (in full duplex mode) 11 = Transferring input frame for transmission	0	RO
19	PAUSE	When high, it indicates that the MAC transmitter is in PAUSE condition (in full-duplex only) and hence will not schedule any frame for transmission.	0	RO
21:20	TXFIFOSTAT	State of the TxFIFO read Controller 00 = idle state 01 = READ state (transferring data to MAC transmitter) 10 = Waiting for TxStatus from MAC transmitter 11 = Writing the received TxStatus or flushing the TxFIFO	0	RO
22	TXFIFOSTAT1	When high, it indicates that the TxFIFO Write Controller is active and transferring data to the TxFIFO.	0	RO
23	-	Reserved	0	RO
24	TXFIFOLVL	When high, it indicates that the TxFIFO is not empty and has some data left for transmission.	0	RO
25	TXFIFOFULL	When high, it indicates that the TxStatus FIFO is full and hence the controller will not be accepting any more frames for transmission.	0	RO
31:26	-	Reserved	-	RO

26.6.10 MAC Remote wake-up frame filter register

This is the address through which the remote Wake-up Frame Filter registers (WKUPFMFILTER) are written/read by the Application. WKUPFMFILTER is actually a pointer to eight (not transparent) such WKUPFMFILTER registers. Eight sequential Writes to this address (0x028) will write all WKUPFMFILTER registers. Eight sequential Reads from this address (0x028) will read all WKUPFMFILTER registers. See [Section 26.7.2.1](#) for details.

Remark: Do not use bit-banding for this register.

Table 533. MAC Remote wake-up frame filter register (MAC_RWAKE_FRFLT, address 0x4001 0028) bit description

Bit	Symbol	Description	Reset value	Access
31:0	ADDR	WKUPFMFILTER address	-	R/W

26.6.11 MAC PMT control and status register

The PMT control and status registers programs the request wake-up events and monitors the wake-up events. See [Section 26.7.2](#) for details.

Table 534. MAC PMT control and status register (MAC_PMT_CTRL_STAT, address 0x4001 002C) bit description

Bit	Symbol	Description	Reset value	Access
0	PD	Power-down This register field can be read by the application (Read), can be set to 1 by the application with a register write of 1 (Write Set), and is cleared to 0 by the core (Self Clear). The application cannot clear this type of field, and a register write of 0 to this bit has no effect on this field. When set, all received frames will be dropped. This bit is cleared automatically when a magic packet or Wake-Up frame is received, and Power-Down mode is disabled. Frames received after this bit is cleared are forwarded to the application. This bit must only be set when either the Magic Packet Enable or Wake-Up Frame Enable bit is set high.	0	R/W
1	MPE	Magic packet enable When set, enables generation of a power management event due to Magic Packet reception.	0	R/W
2	WFE	Wake-up frame enable When set, enables generation of a power management event due to wake-up frame reception.	0	R/W
4:3	-	Reserved	00	RO
5	MPR	Magic Packet Received This register field can be read by the application (Read), can be set to 1 by the Ethernet core on a certain internal event (Self Set), and is automatically cleared to 0 on a register read. A register write of 0 has no effect on this field. When set, this bit indicates the power management event was generated by the reception of a Magic Packet. This bit is cleared by a Read into this register.	0	RO

Table 534. MAC PMT control and status register (MAC_PMT_CTRL_STAT, address 0x4001 002C) bit description

Bit	Symbol	Description	Reset value	Access
6	WFR	Wake-up Frame Received This register field can be read by the application (Read), can be set to 1 by the Ethernet core on a certain internal event (Self Set), and is automatically cleared to 0 on a register read. A register write of 0 has no effect on this field.	0	RO
When set, this bit indicates the power management event was generated due to reception of a wake-up frame. This bit is cleared by a Read into this register.				
8:7	-	Reserved	0	RO
9	GU	Global Unicast When set, enables any unicast packet filtered by the MAC (DAF) address recognition to be a wake-up frame.	0	R/W
30:10	-	Reserved	0x00 0000	RO
31	WFFRPR	Wake-up Frame Filter Register Pointer Reset This register field can be read by the application (Read), can be set to 1 by the application with a register write of 1 (Write Set), and is cleared to 0 by the core (Self Clear). The application cannot clear this type of field, and a register write of 0 to this bit has no effect on this field.	0	R/W
When set, resets the Remote Wake-up Frame Filter register pointer to 000. It is automatically cleared after 1 clock cycle.				

26.6.12 MAC Interrupt status register

The Interrupt Status register contents identify the events in the MAC-CORE that can generate interrupt.

Table 535. MAC Interrupt status register (MAC_INTR, address 0x4001 0038) bit description

Bit	Symbol	Description	Reset value	Access
2:0	-	Reserved.	0	RO
3	PMT	PMT Interrupt Status This bit is set whenever a Magic packet or Wake-on-LAN frame is received in Power- Down mode (See bits 5 and 6 in Table 534). This bit is cleared when both bits[6:5] are cleared because of a read operation to the PMT Control and Status register.	0	RO
8:4	-	Reserved.	0	RO

Table 535. MAC Interrupt status register (MAC_INTR, address 0x4001 0038) bit description

Bit	Symbol	Description	Reset value	Access value
9	TS	Timestamp interrupt status When Advanced Timestamp feature is enabled, this bit is set when any of the following conditions is true: <ul style="list-style-type: none"> • The system time value equals or exceeds the value specified in the Target Time High and Low registers • There is an overflow in the seconds register This bit is cleared on reading the byte 0 of the Timestamp Status register (Table 550). Otherwise, when default Time stamping is enabled, this bit when set indicates that the system time value equals or exceeds the value specified in the Target Time registers. In this mode, this bit is cleared after the completion of the read of this Interrupt Status Register[9]. In all other modes, this bit is reserved.	0	RO
10	-	Reserved.	0	RO
31:11	-	Reserved	0	RO

26.6.13 MAC Interrupt mask register

The Interrupt Mask Register bits enables the user to mask the interrupt signal due to the corresponding event in the Interrupt Status Register.

Table 536. MAC Interrupt mask register (MAC_INTR_MASK, address 0x4001 003C) bit description

Bit	Symbol	Description	Reset value	Access value
2:0	-	Reserved	0	RO
3	PMTIM	PMT Interrupt Mask This bit when set, will disable the assertion of the interrupt signal due to the setting of PMT Interrupt Status bit in Table 535 .	0	R/W
8:4	-	Reserved.		
9	TSIM	Timestamp interrupt mask When set, this bit disables the assertion of the interrupt signal because of the setting of Timestamp Interrupt Status bit in Table 535	0	R/W
10	-	Reserved.		
31:11		Reserved	0	R/W

26.6.14 MAC Address 0 high register

The MAC Address 0 High register holds the upper 16 bits of the 6-byte first MAC address of the station. Note that the first DA byte that is received on the MII interface corresponds to the LS Byte (Bits [7:0]) of the MAC Address Low register. For example, if 0x112233445566 is received (0x11 is the first byte) on the MII as the destination address, then the MacAddress0 Register [47:0] is compared with 0x665544332211.

If the MAC address registers are configured to be double-synchronized to the MII clock domains, then the synchronization is triggered only when Bits[31:24] (in Little-Endian mode) or Bits[7:0] (in Big-Endian mode) of the MAC Address Low Register are written to. Please note that consecutive writes to this Address Low Register should be performed only after at least 4 clock cycles in the destination clock domain for proper synchronization updates.

Table 537. MAC Address 0 high register (MAC_ADDR0_HIGH, address 0x4001 0040) bit description

Bit	Symbol	Description	Reset value	Access
15:0	A47_32	MAC Address0 [47:32] This field contains the upper 16 bits (47:32) of the 6-byte first MAC address. This is used by the MAC for filtering for received frames and for inserting the MAC address in the Transmit Flow Control (PAUSE) Frames.	0xFFFF	R/W
30:16	-	Reserved	0x0000	RO
31	MO	Always 1	1	RO

26.6.15 MAC Address 0 low register

The MAC Address 0 Low register holds the lower 32 bits of the 6-byte first MAC address of the station.

Table 538. MAC Address 0 low register (MAC_ADDR0_LOW, address 0x4001 0044) bit description

Bit	Symbol	Description	Reset value	Access
31:0	A31_0	MAC Address0 [31:0] This field contains the lower 32 bits of the 6-byte first MAC address. This is used by the MAC for filtering for received frames and for inserting the MAC address in the Transmit Flow Control (PAUSE) Frames.	0xFFFF FFFF	R/W

26.6.16 MAC IEEE1588 time stamp control register

This register controls the operation of the System Time generator and the snooping of PTP packets for time-stamping in the Receiver.

Table 539. MAC IEEE1588 time stamp control register (MAC_TIMESTP_CTRL, address 0x4001 0700) bit description

Bit	Symbol	Description	Reset value	Access
0	TSENA	Time Stamp Enable When this bit, is set the timestamping is enabled for transmit and receive frames. When disabled timestamp is not added for transmit and receive frames and the TimeStamp Generator is also suspended. User has to always initialize the TimeStamp (system time) after enabling this mode.	0	R/W
1	TSCFUPDT	Time Stamp Fine or Coarse Update When set, indicates that the system times update to be done using fine update method. When reset it indicates the system time stamp update to be done using Coarse method. This bit is reserved if the fine correction option is not enabled.	0	R/W
2	TSINIT	Time Stamp Initialize This register field can be read and written by the application (Read and Write), and is cleared to 0 by the Ethernet core (Self Clear). When set, the system time is initialized (over-written) with the value specified in the Time Stamp High Update and Time Stamp Low Update registers. This register bit should be read zero before updating it. This bit is reset once the initialize is complete.	0	R/W
3	TSUPDT	Time Stamp Update This register field can be read and written by the application (Read and Write), and is cleared to 0 by the Ethernet core (Self Clear). When set, the system time is updated (added/subtracted) with the value specified in the Time Stamp High Update and Time Stamp Low Update registers. This register bit should be read zero before updating it. This bit is reset once the update is completed in hardware.	0	R/W
4	TSTRIG	Time Stamp Interrupt Trigger Enable This register field can be read and written by the application (Read and Write), and is cleared to 0 by the Ethernet core (Self Clear). When set, the Time Stamp interrupt is generated when the System Time becomes greater than the value written in Target Time register. This bit is reset after the generation of Time Stamp Trigger Interrupt.	0	R/W
5	TSADDREG	Addend Reg Update When set, the contents of the Time Stamp Addend register is updated in the PTP block for fine correction. This is cleared when the update is completed. This register bit should be zero before setting it. This is a reserved bit when only coarse correction option is selected.		
7:6	-	Reserved		
8	TSEBALL	Enable Time Stamp for All Frames When set, the time stamp snapshot is enabled for all frames received by the core.	0	R/W
9	TSCTRLSSR	Time Stamp Digital or Binary rollover control When set, the Time Stamp Low register rolls over after 0x3B9A_C9FF value (i.e., 1 nanosecond accuracy) and increments the Time Stamp (High) seconds. When reset, the rollover value of sub-second register is 0x7FFF_FFFF. The sub-second increment has to be programmed correctly depending on the PTP reference clock frequency and this bit value.	0	R/W
10	TSVER2ENA	Enable PTP packet snooping for version 2 format When set, the PTP packets are snooped using the 1588 version 2 format else snooped using the version 1 format.	0	R/W

Table 539. MAC IEEE1588 time stamp control register (MAC_TIMESTP_CTRL, address 0x4001 0700) bit description

Bit	Symbol	Description	Reset value	Access
11	TSIPENA	Enable Time Stamp Snapshot for PTP over Ethernet frames When set, the time stamp snapshot is taken for frames which have PTP messages in Ethernet frames (PTP over Ethernet) also. By default snapshots are taken for UDP-IP-Ethernet PTP packets.	0	R/W
12	TSIPV6ENA	Enable Time Stamp Snapshot for IPv6 frames When set, the time stamp snapshot is taken for IPv6 frames.	0	R/W
13	TSIPV4ENA	Enable Time Stamp Snapshot for IPv4 frames When set, the time stamp snapshot is taken for IPv4 frames.	1	R/W
14	TSEVNTENA	Enable Time Stamp Snapshot for Event Messages When set, the time stamp snapshot is taken for event messages only. When reset snapshot is taken for all other messages except Announce, Management and Signaling.	0	R/W
15	TSMSTRENA	Enable Snapshot for Messages Relevant to Master When set, the snapshot is taken for messages relevant to master node only else snapshot is taken for messages relevant to slave node. This is valid only for ordinary clock and boundary clock node.	0	R/W
17:16	TSCLKTYPE	Select the type of clock node The following are the options to select the type of clock node: 00 = ordinary clock 01 = boundary clock 10 = end-to-end transparent clock 11 = peer-to-peer transparent clock	00	R/W
18	TSENMADDR	Enable MAC address for PTP frame filtering When set, uses the DA MAC address (that matches any MAC Address register except the default MAC address 0) to filter the PTP frames when PTP is sent directly over Ethernet.	0	R/W
31:19				

[Table 540](#) indicates the messages, for which a snapshot is taken depending on the clock, enable master and enable snapshot for event message register settings.

Table 540. Time stamp snapshot dependency on register bits

TSCLKTYPE	TSMSTRENA	TSEVNTENA	Messages for which snapshot is taken
00 or 01	x	0	SYNC, Follow_Up, Delay_Req, Delay_Resp
00 or 01	1	1	Delay_req
00 or 01	0	1	SYNC
10	N/A	0	SYNC, Follow_Up, Delay_Req, Delay_Resp
10	N/A	1	SYNC, Follow_Up
11	N/A	0	SYNC, Follow_Up, Delay_Req, Delay_Resp, Pdelay_Req, Pdelay_Resp
11	N/A	1	SYNC, Pdelay_Req, Pdelay_Resp

26.6.17 Sub-second increment register

This register contains the 8-bit value by which the Sub-Second register is incremented.

In Coarse Update mode (TSCFUPDT bit in [Table 539](#)), the value in this register is added to the system time every clock cycle. In Fine Update mode, the value in this register is added to the system time whenever the Accumulator gets an overflow.

Table 541. Sub-second increment register (SUBSECOND_INCR, address 0x4001 0704) bit description

Bit	Symbol	Description	Reset value	Access
7:0	SSINC	Sub-second increment value. The value programmed in this register is accumulated with the contents of the sub-second register. For example, to achieve an accuracy of 20 ns, the value to be programmed is 20. (Program 0x14 with a 50 MHz reference clock if 1 ns accuracy is selected.)	0	R/W
31:8	-	Reserved.	0	RO

26.6.18 System time seconds register

This register contains the lower 32 bits of the seconds field of the system time.

The System Time - Seconds register, along with System Time - Nanoseconds register, indicates the current value of the system time maintained by the core. Though it is updated on a continuous basis, there is some delay from the actual time due to clock domain transfer latencies.

Table 542. System time seconds register (SECONDS, address 0x4001 0708) bit description

Bit	Symbol	Description	Reset value	Access
31:0	TSS	Time stamp second The value in this field indicates the current value in seconds of the System Time maintained by the core.	0	R/W

26.6.19 System time nanoseconds register

This register contains 32 bits of the nano-seconds field of the system time.

Table 543. System time nanoseconds register (NANOSECONDS, address 0x4001 070C) bit description

Bit	Symbol	Description	Reset value	Access
30:0	TSSS	Time stamp sub seconds The value in this field has the sub second representation of time, with an accuracy of 0.46 nano-second. (When TSCTRLSSR in the MAC_TIMESTAMP_CTRL register is set, each bit represents 1 ns and the maximum value will be 0x3B9A_C9FF, after which it rolls-over to zero).	0	RO
31	PSNT	Positive or negative time This bit indicates positive or negative time value. If the bit is reset, it indicates that the time representation is positive, and if it is set, it indicates negative time value. (This bit represents the 32nd bit of the nanoseconds value when the Advance Time Stamp feature is enabled).	0	RO

26.6.20 System time seconds update register

This register contains the lower 32 bits of the seconds field to be written to, added to, or subtracted from the System Time value.

The System Time - Seconds Update register, along with the System Time - Nanoseconds Update register, initialize or update the system time maintained by the core. You must write both of these registers before setting the TSINIT or TSUPDT bits in the Time Stamp Control register.

Table 544. System time seconds update register (SECONDSUPDATE, address 0x4001 0710) bit description

Bit	Symbol	Description	Reset value	Access
31:0	TSS	Time stamp second The value in this field indicates the time, in seconds, to be initialized or added to the system time.	0	R/W

26.6.21 System time nanoseconds update register

This register contains 32 bits of the nano-seconds field to be written to, added to, or subtracted from the System Time value.

Table 545. System time nanoseconds update register (NANOSECONDSUPDATE, address 0x4001 0714) bit description

Bit	Symbol	Description	Reset value	Access
30:0	TSSS	Time stamp sub seconds The value in this field has the sub second representation of time, with an accuracy of 0.46 nano-second. (When TSCTRLSSR is set in the time stamp control register, each bit represents 1 ns and the programmed value should not exceed 0x3B9A_C9FF.)	0	R/W
31	ADDSUB	Add or subtract time When this bit is set, the time value is subtracted with the contents of the update register. When this bit is reset, the time value is added with the contents of the update register.	0	R/W

26.6.22 Time stamp addend register

This register is used by the software to readjust the clock frequency linearly to match the master clock frequency.

This register value is used only when the system time is configured for Fine Update mode (TSCFUPDT bit in [Table 539](#)). This register content is added to a 32-bit accumulator in every clock cycle and the system time is updated whenever the accumulator overflows.

Table 546. Time stamp addend register (ADDEND, address 0x4001 0718) bit description

Bit	Symbol	Description	Reset value	Access
31:0	TSAR	Time stamp addend This register indicates the 32-bit time value to be added to the Accumulator register to achieve time synchronization.	0	R/W

26.6.23 Target time seconds register

This register contains the higher 32 bits of time to be compared with the system time for interrupt event generation.

The Target Time Seconds register, along with Target Time Nanoseconds register, are used to schedule an interrupt event (TSTARGET bit in [Table 550](#) when Advanced Timestamping is enabled, or otherwise, TS interrupt bit in [Table 535](#)) when the system time exceeds the value programmed in these registers.

Table 547. Target time seconds register (TARGETSECONDS, address 0x4001 071C) bit description

Bit	Symbol	Description	Reset value	Access
31:0	TSTR	Target time seconds register This register stores the time in seconds. When the time stamp value matches or exceeds both Target Time Stamp registers, the MAC, if enabled, generates an interrupt.	0	R/W

26.6.24 Target time nanoseconds register

This register contains the higher 32 bits of time to be compared with the system time for interrupt event generation.

Table 548. Target time nanoseconds register (TARGETNANOSECONDS, address 0x4001 0720) bit description

Bit	Symbol	Description	Reset value	Access
30:0	TSTR	Target time stamp low This register stores the time in (signed) nanoseconds. When the value of the Time Stamp matches the Target time stamp registers (both), the MAC will generate an interrupt if enabled. (This value should not exceed 0x3B9A_C9FF when TSCTRLSSR is set in the time stamp control register.)	0	RO
31	-	Reserved.	-	-

26.6.25 System time higher words seconds register

This register contains the most significant 16-bits of the time stamp seconds value.

Table 549. System time higher words seconds register (HIGHWORD, address 0x4001 0724) bit description

Bit	Symbol	Description	Reset value	Access
15:0	TSHWR	Time stamp higher word Contains the most significant 16-bits of the time stamp seconds value. The register is directly written to initialize the value. This register is incremented when there is an overflow from the 32-bits of the System Time - Seconds register.	0	R/W
31:16	-	Reserved.	-	-

26.6.26 Time stamp status register

This register contains the PTP status. All bits except Bits[27:25] gets cleared after this register is read by the host.

The register field can be read by the application (Read), can be set to 1 by the core on a certain internal event (Self Set), and is automatically cleared to 0 on a register read. A register write of 0 has no effect on this field.

Table 550. Time stamp status register (TIMESTAMPSTAT, address 0x4001 0728) bit description

Bit	Symbol	Description	Reset value	Access
0	TSSOVF	Time stamp seconds overflow When set, indicates that the seconds value of the time stamp (when supporting version 2 format) has overflowed beyond 0xFFFF_FFFF.	0	R/W
1	TSTARGT	Time stamp target reached When set, indicates the value of system time is greater or equal to the value specified in the Target Time High and Low registers	0	R/W
31:2	-	Reserved.	-	-

26.6.27 DMA Bus mode register

The Bus Mode register establishes the bus operating modes for the DMA.

Table 551. DMA Bus mode register (DMA_BUS_MODE, address 0x4001 1000) bit description

Bit	Symbol	Description	Reset value	Access
0	SWR	Software reset This register field can be read by the application (Read), can be set to 1 by the application with a register write of 1 (Write Set), and is cleared to 0 by the Ethernet core (Self Clear). The application cannot clear this type of field, and a register write of 0 to this bit has no effect on this field. When this bit is set, the MAC DMA Controller resets all MAC Subsystem internal registers and logic. It is cleared automatically after the reset operation has completed in all of the core clock domains. Read a 0 value in this bit before re-programming any register of the core. Remark: The reset operation is completed only when all the resets in all the active clock domains are de-asserted. Hence it is essential that all the PHY inputs clocks (applicable for the selected PHY interface) are present for software reset completion.	0	R/W
1	DA	DMA arbitration scheme 0 = Round-robin with Rx:Tx priority given in bits [15:14] 1 = Rx has priority over Tx	0	R/W
6:2	DSL	Descriptor skip length This bit specifies the number of Word to skip between two unchained descriptors. The address skipping starts from the end of current descriptor to the start of next descriptor. When DSL value equals zero, then the descriptor table is taken as contiguous by the DMA, in Ring mode.	0	R/W
7	ATDS	Alternate descriptor size When set, the alternate descriptor (see Section 26.7.6.3) size is increased to 32 bytes (8 DWORDS). This is required when the Advanced Time-Stamp feature or Full IPC Offload Engine is enabled in the receiver. When reset, the descriptor size reverts back to 4 DWORDs (16 bytes).	0	R/W

Table 551. DMA Bus mode register (DMA_BUS_MODE, address 0x4001 1000) bit description ...continued

Bit	Symbol	Description	Reset value	Access
13:8	PBL	<p>Programmable burst length</p> <p>These bits indicate the maximum number of beats to be transferred in one DMA transaction. This will be the maximum value that is used in a single block Read/Write. The DMA will always attempt to burst as specified in PBL each time it starts a Burst transfer on the host bus. PBL can be programmed with permissible values of 1, 2, 4, 8, 16, and 32. Any other value will result in undefined behavior. When USP is set high, this PBL value is applicable for TxDMA transactions only.</p> <p>The PBL values have the following limitations.</p> <p>The maximum number of beats (PBL) possible is limited by the size of the Tx FIFO and Rx FIFO in the MTL layer and the data bus width on the DMA. The FIFO has a constraint that the maximum beat supported is half the depth of the FIFO, except when specified (as given below). For different data bus widths and FIFO sizes, the valid PBL range (including x8 mode) is provided in the following table. If the PBL is common for both transmit and receive DMA, the minimum Rx FIFO and Tx FIFO depths must be considered. Do not program out-of-range PBL values, because the system may not behave properly.</p>	1	R/W
15:14	PR	<p>Rx-to-Tx priority ratio</p> <p>RxDMA requests given priority over TxDMA requests in the following ratio. This is valid only when the DA bit is reset.</p> <p>00 = 1-to-1 01 = 2-to-1 10 = 3-to-1 11 = 4-to-1</p>	00	R/W
16	FB	<p>Fixed burst</p> <p>This bit controls whether the AHB Master interface performs fixed burst transfers or not. When set, the AHB will use only SINGLE, INCR4, INCR8 or INCR16 during start of normal burst transfers. When reset, the AHB will use SINGLE and INCR burst transfer operations.</p>	0	R/W
22:17	RPBL	<p>RxDMA PBL</p> <p>These bits indicate the maximum number of beats to be transferred in one RxDMA transaction. This will be the maximum value that is used in a single block Read/Write. The RxDMA will always attempt to burst as specified in RPBL each time it starts a Burst transfer on the host bus. RPBL can be programmed with permissible values of 1, 2, 4, 8, 16, and 32. Any other value will result in undefined behavior. These bits are valid and applicable only when USP is set high.</p>	1	R/W
23	USP	<p>Use separate PBL</p> <p>When set high, it configures the RxDMA to use the value configured in bits [22:17] as PBL while the PBL value in bits [13:8] is applicable to TxDMA operations only. When reset to low, the PBL value in bits [13:8] is applicable for both DMA engines.</p>	0	R/W
24	PBL8X	<p>8 x PBL mode</p> <p>When set high, this bit multiplies the PBL value programmed (bits [22:17] and bits [13:8]) eight times. Thus the DMA will transfer data in to a maximum of 8, 16, 32, 64, 128, and 256 beats depending on the PBL value.</p> <p>Remark: This bit function is not backward compatible. Before version 3.50a, this bit was 4xPBL.</p>	0	R/W

Table 551. DMA Bus mode register (DMA_BUS_MODE, address 0x4001 1000) bit description ...continued

Bit	Symbol	Description	Reset value	Access
25	AAL	Address-aligned beats When this bit is set high and the FB bit equals 1, the AHB interface generates all bursts aligned to the start address LS bits. If the FB bit equals 0, the first burst (accessing the data buffer's start address) is not aligned, but subsequent bursts are aligned to the address.	0	R/W
26	MB	Mixed burst When this bit is set high and FB bit is low, the AHB master interface will start all bursts of length more than 16 with INCR (undefined burst) whereas it will revert to fixed burst transfers (INCRx and SINGLE) for burst-length of 16 and below.	0	R/W
27	TXPR	When set, this bit indicates that the transmit DMA has higher priority than the receive DMA during arbitration for the system-side bus.	0	R/W
31:28	-	Reserved	0	RO

Table 552. Programmable burst length settings

Data bus width	FIFO depth	Valid PBL range in full duplex mode
32 bit	128 bytes	8 or less
	256 bytes	32 or less
	512 bytes	64 or less
	1 kB	128 or less
	2 kB and above	all

26.6.28 DMA Transmit poll demand register

The Transmit Poll Demand register enables the Transmit DMA to check whether or not the current descriptor is owned by DMA. The Transmit Poll Demand command is given to wake up the TxDMA if it is in Suspend mode. The TxDMA can go into Suspend mode due to an Underflow error in a transmitted frame or due to the unavailability of descriptors owned by Transmit DMA. You can give this command anytime and the TxDMA will reset this command once it starts re-fetching the current descriptor from host memory.

Table 553. DMA Transmit poll demand register (DMA_TRANS_POLL_DEMAND, address 0x4001 1004) bit description

Bit	Symbol	Description	Reset value	Access
31:0	TPD	Transmit poll demand This register field can be read by the application, and when a write operation is performed with any data value, an event is triggered. When these bits are written with any value, the DMA reads the current descriptor pointed to by the Current Host Transmit Descriptor register (Section 26.6.37). If that descriptor is not available (owned by Host), transmission returns to the Suspend state and bit 2 in the DMA_STAT Register is asserted. If the descriptor is available, transmission resumes.	0	R/W

26.6.29 DMA Receive poll demand register

The Receive Poll Demand register enables the receive DMA to check for new descriptors. This command is given to wake up the RxDMA from SUSPEND state. The RxDMA can go into SUSPEND state only due to the unavailability of descriptors owned by it.

Table 554. DMA Receive poll demand register (DMA_REC_POLL_DEMAND, address 0x4001 1008) bit description

Bit	Symbol	Description	Reset value	Access
31:0	RPD	<p>Receive poll demand</p> <p>This register field can be read by the application, and when a write operation is performed with any data value, an event is triggered.</p> <p>When these bits are written with any value, the DMA reads the current descriptor pointed to by the Current Host Receive Descriptor register (Section 26.6.38). If that descriptor is not available (owned by Host), reception returns to the Suspended state and bit 7 in the DMA_STAT Register is not asserted. If the descriptor is available, the Receive DMA returns to active state.</p>	0	R/W

26.6.30 DMA Receive descriptor list address register

The Receive Descriptor List Address register points to the start of the Receive Descriptor List. The descriptor lists reside in the host's physical memory space and must be Word-aligned. The DMA internally converts it to bus width aligned address by making the corresponding LS bits low. Writing to this register is permitted only when reception is stopped. When stopped, this register must be written to before the receive Start command is given.

Table 555. DMA Receive descriptor list address register (DMA_REC_DES_ADDR, address 0x4001 100C) bit description

Bit	Symbol	Description	Reset value	Access
31:0	SRL	<p>Start of receive list</p> <p>This field contains the base address of the First Descriptor in the Receive Descriptor list. The LSB bit 1 will be ignored and taken as all-zero by the DMA internally. Hence these LSB bits are Read Only.</p>	0	R/W

26.6.31 DMA Transmit descriptor list address register

The Transmit Descriptor List Address register points to the start of the Transmit Descriptor List. The descriptor lists reside in the host's physical memory space and must be Word-aligned. The DMA internally converts it to bus width aligned address by making the corresponding LSB to low. Writing to this register is permitted only when transmission has stopped. When stopped, this register can be written before the transmission Start command is given.

Table 556. DMA Transmit descriptor list address register (DMA_TRANS_DES_ADDR, address 0x4001 1010) bit description

Bit	Symbol	Description	Reset value	Access
31:0	SRL	Start of transmit list This field contains the base address of the First Descriptor in the Transmit Descriptor list. The LSB bit 1 will be ignored and taken as all-zero by the DMA internally. Hence these LSB bits are Read Only.	0	R/W

26.6.32 DMA Status register

The Status register contains all the status bits that the DMA reports to the host. This register is usually read by the Software driver during an interrupt service routine or polling. Most of the fields in this register cause the host to be interrupted. The bits in this register are not cleared when read. Writing 1 to (unreserved) bits in this register (bits [16:0]) clears them and writing 0 has no effect. Each field (bits[16:0]) can be masked by masking the appropriate bit in the DMA_INT_EN register.

This fields in this register can be read by the application (Read), can be set to 1 by the Ethernet core on a certain internal event (Self Set), and can be cleared to 0 by the application with a register write of 1 (Write Clear). A register write of 0 has no effect on this field.

Table 557. DMA Status register (DMA_STAT, address 0x4001 1014) bit description

Bit	Symbol	Description	Reset value	Access
0	TI	Transmit interrupt This bit indicates that frame transmission is finished and TDES1[31] is set in the First Descriptor.	0	R/W
1	TPS	Transmit process stopped This bit is set when the transmission is stopped.	0	R/W
2	TU	Transmit buffer unavailable This bit indicates that the Next Descriptor in the Transmit List is owned by the host and cannot be acquired by the DMA. Transmission is suspended. Bits[22:20] explain the Transmit Process state transitions. To resume processing transmit descriptors, the host should change the ownership of the bit of the descriptor and then issue a Transmit Poll Demand command.	0	R/W
3	TJT	Transmit jabber timeout This bit indicates that the Transmit Jabber Timer expired, meaning that the transmitter had been excessively active. The transmission process is aborted and placed in the Stopped state. This causes the Transmit Jabber Timeout TDES0[14] flag to assert.	0	R/W
4	OVF	Receive overflow This bit indicates that the Receive Buffer had an Overflow during frame reception. If the partial frame is transferred to application, the overflow status is set in RDES0[11].	0	R/W
5	UNF	Transmit underflow This bit indicates that the Transmit Buffer had an Underflow during frame transmission. Transmission is suspended and an Underflow Error TDES0[1] is set.	0	R/W

Table 557. DMA Status register (DMA_STAT, address 0x4001 1014) bit description ...continued

Bit	Symbol	Description	Reset value	Access
6	RI	Receive interrupt This bit indicates the completion of frame reception. Specific frame status information has been posted in the descriptor. Reception remains in the Running state.	0	R/W
7	RU	Receive buffer unavailable This bit indicates that the Next Descriptor in the Receive List is owned by the host and cannot be acquired by the DMA. Receive Process is suspended. To resume processing Receive descriptors, the host should change the ownership of the descriptor and issue a Receive Poll Demand command. If no Receive Poll Demand is issued, Receive Process resumes when the next recognized incoming frame is received. This bit is set only when the previous Receive Descriptor was owned by the DMA.	0	R/W
8	RPS	Received process stopped This bit is asserted when the Receive Process enters the Stopped state.	0	R/W
9	RWT	Receive watchdog timeout This bit is asserted when a frame with a length greater than 2,048 bytes is received (10,240 when Jumbo Frame mode is enabled).	0	R/W
10	ETI	Early transmit interrupt This bit indicates that the frame to be transmitted was fully transferred to the MTL Transmit FIFO.	0	R/W
12:11	-	Reserved	0	RO
13	FBI	Fatal bus error interrupt This bit indicates that a bus error occurred, as detailed in bits [25:23]. When this bit is set, the corresponding DMA engine disables all its bus accesses.	0	R/W
14	ERI	Early receive interrupt This bit indicates that the DMA had filled the first data buffer of the packet. Receive Interrupt bit 6 in this register automatically clears this bit.	0	R/W
15	AIE	Abnormal interrupt summary Abnormal Interrupt Summary bit value is the logical OR of the following when the corresponding interrupt bits are enabled in the DMA_INT_EN register: DMA_STAT register, bit 1: Transmit process stopped DMA_STAT register, bit 3: Transmit jabber timeout DMA_STAT register, bit 4: Receive overflow DMA_STAT register, bit 5: Transmit underflow DMA_STAT register, bit 7: Receiver buffer unavailable DMA_STAT register, bit 8: Receive process stopped DMA_STAT register, bit 9: Receive watchdog timeout DMA_STAT register, bit 10: Early transmit interrupt DMA_STAT register, bit 13: Fatal bus error Only unmasked bits affect the Abnormal Interrupt Summary bit. This is a sticky bit and must be cleared each time a corresponding bit that causes AIS to be set is cleared.	0	R/W

Table 557. DMA Status register (DMA_STAT, address 0x4001 1014) bit description ...continued

Bit	Symbol	Description	Reset value	Access
16	NIS	<p>Normal interrupt summary</p> <p>Normal Interrupt Summary bit value is the logical OR of the following when the corresponding interrupt bits are enabled in the DMA_INT_EN register:</p> <p>DMA_STAT register, bit 0: Transmit interrupt</p> <p>DMA_STAT register, bit 2: Transmit buffer unavailable</p> <p>DMA_STAT register, bit 6: Receive interrupt</p> <p>DMA_STAT register, bit 14: Early receive interrupt</p> <p>Only unmasked bits affect the Normal Interrupt Summary bit.</p> <p>This is a sticky bit and must be cleared (by writing a 1 to this bit) each time a corresponding bit that causes NIS to be set is cleared.</p>	0	R/W
19:17	RS	<p>Receive Process State</p> <p>These bits indicate the receive DMA state machine state. This field does not generate an interrupt.</p> <p>000 = Stopped: Reset or Stop Receive Command issued.</p> <p>001 = Running: Fetching Receive Transfer Descriptor.</p> <p>010 = Reserved.</p> <p>011 = Running: Waiting for receive packet.</p> <p>100 = Suspended: Receive Descriptor Unavailable.</p> <p>101 = Running: Closing Receive Descriptor.</p> <p>110 = TIME_STAMP write state.</p> <p>111 = Running: Transferring the receive packet data from receive buffer to host memory.</p>	0	RO
22:20	TS	<p>Transmit Process State</p> <p>These bits indicate the transmit DMA state machine state. This field does not generate an interrupt.</p> <p>000 = Stopped; Reset or Stop Transmit Command issued.</p> <p>001 = Running; Fetching Transmit Transfer Descriptor.</p> <p>010 = Running; Waiting for status.</p> <p>011 = Running; Reading Data from host memory buffer and queuing it to transmit buffer (Tx FIFO).</p> <p>100 = TIME_STAMP write state.</p> <p>101 = Reserved.</p> <p>110 = Suspended; Transmit Descriptor Unavailable or Transmit Buffer Underflow.</p> <p>111 = Running; Closing Transmit Descriptor.</p>	000	RO
23	EB1	<p>Error bit 1</p> <p>This bit indicates the type of error that caused a Bus Error (e.g., error response on the AHB interface). This bit is valid only when bit 13 in this register is set. This field does not generate an interrupt.</p> <p>1 = Error during data transfer by TxDMA.</p> <p>0 = Error during data transfer by RxDMA.</p>	0	RO

Table 557. DMA Status register (DMA_STAT, address 0x4001 1014) bit description ...continued

Bit	Symbol	Description	Reset value	Access
24	EB2	Error bit 2 This bit indicates the type of error that caused a Bus Error (e.g., error response on the AHB interface). This bits is valid only when bit 13 in this register is set. This field does not generate an interrupt. 1 = Error during read transfer. 0 = Error during write transfer.	0	RO
25	EB3	Error bit 3 This bit indicates the type of error that caused a Bus Error (e.g., error response on the AHB interface). This bits is valid only when bit 13 in this register is set. This field does not generate an interrupt. 1 = Error during descriptor access. 0 = Error during data buffer access.	0	RO
31:26	-	Reserved	0	RO

26.6.33 DMA Operation mode register

The Operation Mode register establishes the Transmit and Receive operating modes and commands. This register should be the last CSR to be written as part of DMA initialization.

Table 558. DMA operation mode register (DMA_OP_MODE, address 0x4001 1018) bit description

Bit	Symbol	Description	Reset value	Access
0	-	Reserved	0	RO
1	SR	Start/stop receive When this bit is set, the Receive process is placed in the Running state. The DMA attempts to acquire the descriptor from the Receive list and processes incoming frames. Descriptor acquisition is attempted from the current position in the list, which is the address set by the DMA_REC_DES_ADDR register or the position retained when the Receive process was previously stopped. If no descriptor is owned by the DMA, reception is suspended and Receive Buffer Unavailable bit (bit 7 in DMA_STAT register) is set. The Start Receive command is effective only when reception has stopped. If the command was issued before setting the DMA_REC_DES_ADDR, DMA behavior is unpredictable.	0	R/W
2	OSF	Operate on second frame When this bit is set, this bit instructs the DMA to process a second frame of Transmit data even before status for first frame is obtained.	0	R/W
4:3	RTC	Receive threshold control These two bits control the threshold level of the MTL Receive FIFO. Transfer (request) to DMA starts when the frame size within the MTL Receive FIFO is larger than the threshold. In addition, full frames with a length less than the threshold are transferred automatically. These bits are valid only when the RSF bit is zero, and are ignored when the RSF bit is set to 1. 00 = 64 01 = 32 10 = 96 11 = 128	0	R/W
5	-	Reserved	0	RO

Table 558. DMA operation mode register (DMA_OP_MODE, address 0x4001 1018) bit description ...continued

Bit	Symbol	Description	Reset value	Access
6	FUF	Forward undersized good frames When set, the Rx FIFO will forward Undersized frames (frames with no Error and length less than 64 bytes) including pad-bytes and CRC). When reset, the Rx FIFO will drop all frames of less than 64 bytes, unless it is already transferred due to lower value of Receive Threshold (e.g., RTC = 01).	0	R/W
7	FEF	Forward error frames When this bit is reset, the Rx FIFO drops frames with error status (CRC error, collision error, , watchdog timeout, overflow). However, if the frame's start byte (write) pointer is already transferred to the read controller side (in Threshold mode), then the frames are not dropped. When FEF is set, all frames except runt error frames are forwarded to the DMA. But when RxFIFO overflows when a partial frame is written, then such frames are dropped even when FEF is set.	0	R/W
12:8	-	Reserved	0	RO
13	ST	Start/Stop Transmission Command When this bit is set, transmission is placed in the Running state, and the DMA checks the Transmit List at the current position for a frame to be transmitted. Descriptor acquisition is attempted either from the current position in the list, which is the Transmit List Base Address set by the DMA_TRANS_DES_ADDR register or from the position retained when transmission was stopped previously. If the current descriptor is not owned by the DMA, transmission enters the Suspended state and Transmit Buffer Unavailable (DMA_STAT register, bit 2) is set. The Start Transmission command is effective only when transmission is stopped. If the command is issued before setting the DMA_TRANS_DES_ADDR register, then the DMA behavior is unpredictable. When this bit is reset, the transmission process is placed in the Stopped state after completing the transmission of the current frame. The Next Descriptor position in the Transmit List is saved, and becomes the current position when transmission is restarted. The stop transmission command is effective only the transmission of the current frame is complete or when the transmission is in the Suspended state.	0	R/W
16:14	TTC	Transmit threshold control These three bits control the threshold level of the MTL Transmit FIFO. Transmission starts when the frame size within the MTL Transmit FIFO is larger than the threshold. In addition, full frames with a length less than the threshold are also transmitted. These bits are used only when the TSF bit (Bit 21) is reset. 000 = 64 001 = 128 010 = 192 011 = 256 100 = 40 101 = 32 110 = 24 111 = 16	0	R/W
19:17	-	Reserved	0	RO

Table 558. DMA operation mode register (DMA_OP_MODE, address 0x4001 1018) bit description ...continued

Bit	Symbol	Description	Reset value	Access
20	FTF	Flush transmit FIFO This register field can be read by the application (Read), can be set to 1 by the application with a register write of 1 (Write Set), and is cleared to 0 by the Ethernet core (Self Clear). The application cannot clear this type of field, and a register write of 0 to this bit has no effect on this field. When this bit is set, the transmit FIFO controller logic is reset to its default values and thus all data in the Tx FIFO is lost/flushed. This bit is cleared internally when the flushing operation is completed fully. The Operation Mode register should not be written to until this bit is cleared. The data which is already accepted by the MAC transmitter will not be flushed. It will be scheduled for transmission and will result in underflow and runt frame transmission. Remark: The flush operation completes only after emptying the TxFIFO of its contents and all the pending Transmit Status of the transmitted frames are accepted by the host. In order to complete this flush operation, the PHY transmit clock is required to be active.	0	R/W
21	-	Reserved	0	RO
23:22	-	Reserved	0	RO
24	DFF	Disable flushing of received frames When this bit is set, the RxDMA does not flush any frames due to the unavailability of receive descriptors/buffers as it does normally when this bit is reset. (See).	0	R/W
25	-	Reserved	0	RO
26	-	Reserved	0	RO
31:27	-	Reserved	0	RO

26.6.34 DMA Interrupt enable register

The Interrupt Enable register enables the interrupts reported by the DMA_STAT register. Setting a bit to 1 enables a corresponding interrupt. After a hardware or software reset, all interrupts are disabled.

Table 559. DMA Interrupt enable register (DMA_INT_EN, address 0x4001 101C) bit description

Bit	Symbol	Description	Reset value	Access
0	TIE	Transmit interrupt enable When this bit is set with Normal Interrupt Summary Enable (bit 16 in this register), Transmit Interrupt is enabled. When this bit is reset, Transmit Interrupt is disabled.	0	R/W
1	TSE	Transmit stopped enable When this bit is set with Abnormal Interrupt Summary Enable (bit 15 in this register), Transmission Stopped Interrupt is enabled. When this bit is reset, Transmission Stopped Interrupt is disabled.	0	R/W
2	TUE	Transmit buffer unavailable enable When this bit is set with Normal Interrupt Summary Enable (bit 16 in this register), Transmit Buffer Unavailable Interrupt is enabled. When this bit is reset, Transmit Buffer Unavailable Interrupt is disabled.	0	R/W

Table 559. DMA Interrupt enable register (DMA_INT_EN, address 0x4001 101C) bit description ...continued

Bit	Symbol	Description	Reset value	Access
3	TJE	Transmit jabber timeout enable When this bit is set with Abnormal Interrupt Summary Enable (bit 15 in this register), Transmit Jabber Timeout Interrupt is enabled. When this bit is reset, Transmit Jabber Timeout Interrupt is disabled.	0	R/W
4	OVE	Overflow interrupt enable When this bit is set with Abnormal Interrupt Summary Enable (bit 15 in this register), Receive Overflow Interrupt is enabled. When this bit is reset, Overflow Interrupt is disabled.	0	R/W
5	UNE	Underflow interrupt enable When this bit is set with Abnormal Interrupt Summary Enable (bit 15 in this register), Transmit Underflow Interrupt is enabled. When this bit is reset, Underflow Interrupt is disabled.	0	R/W
6	RIE	Receive interrupt enable When this bit is set with Normal Interrupt Summary Enable (bit 16 in this register), Receive Interrupt is enabled. When this bit is reset, Receive Interrupt is disabled.	0	R/W
7	RUE	Receive buffer unavailable enable When this bit is set with Abnormal Interrupt Summary Enable (bit 15 in this register), Receive Buffer Unavailable Interrupt is enabled. When this bit is reset, the Receive Buffer Unavailable Interrupt is disabled.	0	R/W
8	RSE	Received stopped enable When this bit is set with Abnormal Interrupt Summary Enable (bit 15 in this register), Receive Stopped Interrupt is enabled. When this bit is reset, Receive Stopped Interrupt is disabled.	0	R/W
9	RWE	Receive watchdog timeout enable When this bit is set with Abnormal Interrupt Summary Enable (bit 15 in this register), the Receive Watchdog Timeout Interrupt is enabled. When this bit is reset, Receive Watchdog Timeout Interrupt is disabled.	0	R/W
10	ETE	Early transmit interrupt enable When this bit is set with an Abnormal Interrupt Summary Enable (bit 15 in this register), Early Transmit Interrupt is enabled. When this bit is reset, Early Transmit Interrupt is disabled.	0	R/W
12:11	-	Reserved	0	RO
13	FBE	Fatal bus error enable When this bit is set with Abnormal Interrupt Summary Enable (bit 15 in this register), the Fatal Bus Error Interrupt is enabled. When this bit is reset, Fatal Bus Error Enable Interrupt is disabled.	0	R/W
14	ERE	Early receive interrupt enable When this bit is set with Normal Interrupt Summary Enable (bit 16 in this register), Early Receive Interrupt is enabled. When this bit is reset, Early Receive Interrupt is disabled.	0	R/W

Table 559. DMA Interrupt enable register (DMA_INT_EN, address 0x4001 101C) bit description ...continued

Bit	Symbol	Description	Reset value	Access
15	AIE	Abnormal interrupt summary enable When this bit is set, an Abnormal Interrupt is enabled. When this bit is reset, an Abnormal Interrupt is disabled. This bit enables the following bits DMA_STAT register, bit 1: Transmit process stopped DMA_STAT register, bit 3: Transmit jabber timeout DMA_STAT register, bit 4: Receive overflow DMA_STAT register, bit 5: Transmit underflow DMA_STAT register, bit 7: Receiver buffer unavailable DMA_STAT register, bit 8: Receive process stopped DMA_STAT register, bit 9: Receive watchdog timeout DMA_STAT register, bit 10: Early transmit interrupt DMA_STAT register, bit 13: Fatal bus error	0	R/W
16	NIE	Normal interrupt summary enable When this bit is set, a normal interrupt is enabled. When this bit is reset, a normal interrupt is disabled. This bit enables the following bits: DMA_STAT register, bit 0: Transmit interrupt DMA_STAT register, bit 2: Transmit buffer unavailable DMA_STAT register, bit 6: Receive interrupt DMA_STAT register, bit 14: Early receive interrupt	0	R/W
31:17	-	Reserved	0	RO

The interrupt (sbd_intr_o_interrupt) is generated as shown in [Figure 67](#). It is asserted when the NIS/AIS Status bit is asserted and the corresponding Interrupt Enable bits (NIE/AIE) are enabled.

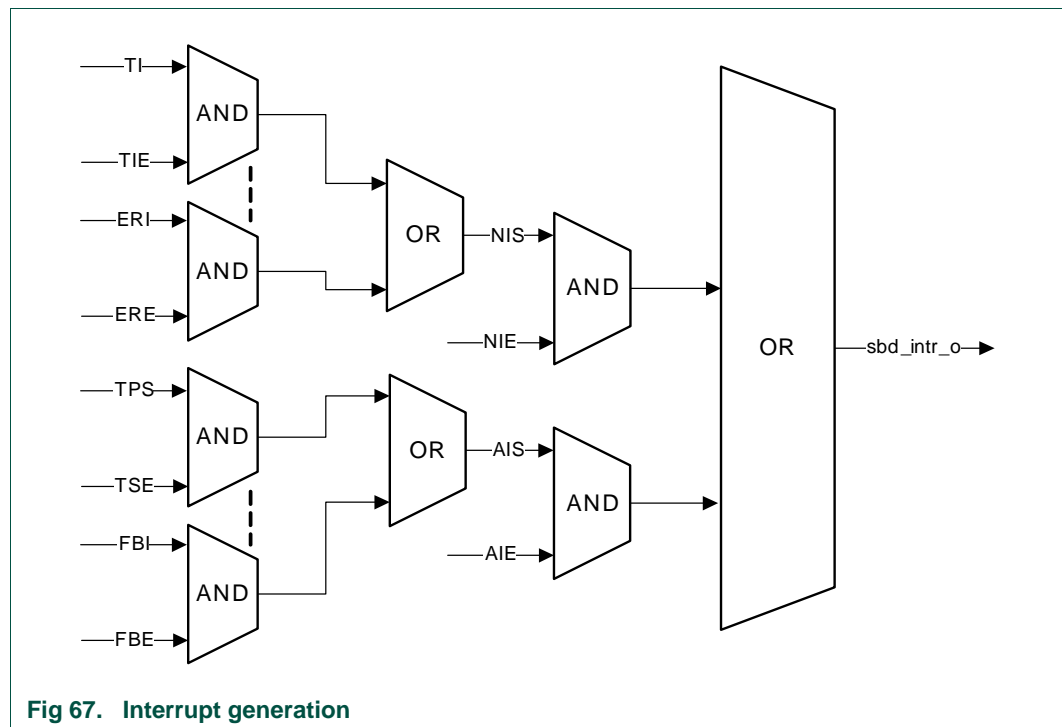

Fig 67. Interrupt generation

26.6.35 DMA Missed frame and buffer overflow counter register

The DMA maintains two counters to track the number of missed frames during reception. This register reports the current value of the counter. The counter is used for diagnostic purposes. Bits[15:0] indicate missed frames due to the host buffer being unavailable. Bits[27:17] indicate missed frames due to buffer overflow conditions and runt frames (good frames of less than 64 bytes) dropped by the MTL.

Table 560. DMA Missed frame and buffer overflow counter register (DMA_MFRM_BUFOF, address 0x4001 1020) bit description

Bit	Symbol	Description	Reset value	Access
15:0	FMC	Number of frames missed This register field can be read by the application (Read), can be set to 1 by the Ethernet core on a certain internal event (Self Set), and is automatically cleared to 0 on a register read. A register write of 0 has no effect on this field. Indicates the number of frames missed by the controller due to the Host Receive Buffer being unavailable. This counter is incremented each time the DMA discards an incoming frame. The counter is cleared when this register is read.	0	RO
16	OC	Overflow bit for missed frame counter This register field can be read by the application (Read), can be set to 1 by the Ethernet core on a certain internal event (Self Set), and is automatically cleared to 0 on a register read. A register write of 0 has no effect on this field.	0	RO
27:17	FMA	Number of frames missed by the application This register field can be read by the application (Read), can be set to 1 by the Ethernet core on a certain internal event (Self Set), and is automatically cleared to 0 on a register read. A register write of 0 has no effect on this field. Indicates the number of frames missed by the application. This counter is incremented each time the MTL asserts the sideband signal. The counter is cleared when this register is read.	0	RO
28	OF	Overflow bit for FIFO overflow counter This register field can be read by the application (Read), can be set to 1 by the Ethernet core on a certain internal event (Self Set), and is automatically cleared to 0 on a register read. A register write of 0 has no effect on this field.	0	RO
31:29	-	Reserved	0	RO

26.6.36 DMA Receive interrupt watchdog timer register

This register, when written with non-zero value, will enable the watchdog timer for RI (bit 6 in the DMA_STAT register).

Table 561. DMA Receive interrupt watchdog timer register (DMA_REC_INT_WDT, address 0x4001 1024) bit description

Bit	Symbol	Description	Reset value	Access
7:0	RIWT	RI watchdog timeout Indicates the number of system clock cycles multiplied by 256 for which the watchdog timer is set. The watchdog timer gets triggered with the programmed value after the RxDMA completes the transfer of a frame for which the RI status bit is not set due to the setting in the corresponding descriptor RDES1[31]. When the watch-dog timer runs out, the RI bit is set and the timer is stopped. The watchdog timer is reset when RI bit is set high due to automatic setting of RI as per RDES1[31] of any received frame.	0	R/W
31:8	-	Reserved	0	RO

26.6.37 DMA Current host transmit descriptor register

The Current Host Transmit Descriptor register points to the start address of the current Transmit Descriptor read by the DMA.

Table 562. DMA Current host transmit descriptor register (DMA_CURHOST_TRANS_DES, address 0x4001 1048) bit description

Bit	Symbol	Description	Reset value	Access
31:0	HTD	Host Transmit Descriptor Address Pointer Cleared on Reset. Pointer updated by DMA during operation.	0	RO

26.6.38 DMA Current host receive descriptor register

The Current Host Receive Descriptor register points to the start address of the current Receive Descriptor read by the DMA.

Table 563. DMA Current host receive descriptor register (DMA_CURHOST_REC_DES, address 0x4001 104C) bit description

Bit	Symbol	Description	Reset value	Access
31:0	HRD	Host Receive Descriptor Address Pointer Cleared on Reset. Pointer updated by DMA during operation.	0	RO

26.6.39 DMA Current host transmit buffer address register

The Current Host Transmit Buffer Address register points to the current Transmit Buffer Address being read by the DMA.

Table 564. DMA Current host transmit buffer address register (DMA_CURHOST_TRANS_BUF, address 0x4001 1050) bit description

Bit	Symbol	Description	Reset value	Access
31:0	HTB	Host Transmit Buffer Address Pointer Cleared on Reset. Pointer updated by DMA during operation.	0	RO

26.6.40 DMA Current host receive buffer address register

The Current Host Receive Buffer Address register points to the current Receive Buffer address being read by the DMA.

Table 565. DMA Current host receive buffer address register (DMA_CURHOST_REC_BUF, address 0x4001 1054) bit description

Bit	Symbol	Description	Reset value	Access
31:0	HRB	Host Receive Buffer Address Pointer Cleared on Reset. Pointer updated by DMA during operation.	0	RO

26.7 Functional description

26.7.1 Hash filter

To use the hash filter, follow these steps:

1. Calculate CRC32 from the DA (Destination Address) MAC address.
2. Perform a bit-wise reversal of the last two bytes of the value obtained in step 1.
3. Use the first 6 bits of the value obtained in step 2 as follows:
 - The most significant bit determines the hash table register to use.
 - The other 5 bits determine the bit to set in the selected register.
4. In the MAC_FRAME_REGISTER, enable the HMC bit (bit 2) for multicast hash filtering or the HUC bit (bit 1) for unicast hash filtering.

26.7.1.1 Example for a unicast MAC address

MAC: 5e-45-a2-6c-30-1e

CRC32: 0x94B3F747

Last 2 bytes in binary: 0100 0111

Bit-wise reversal: 1110 0010

First 6 bits: 111000 (1=Hash Table High / 11000 => 0x18 => bit 24)

In the MAC_HASH_TABLE_HIGH register write a 1 to bit 24.

In the MAC_FRAME_FILTER register, set the HUC bit (bit 1) to 1.

26.7.1.2 Example for a multicast MAC address

MAC: 01-45-a2-6c-30-33

CRC32: 0x2CB41110

Last 2 bytes in binary: 0001 0000

Bit-wise reversal: 0000 1000

First 6 bits: 000010 (0=Hash Table Low / 00010 => 0x2 => bit 2)

In the MAC_HASH_TABLE_LOW register, write a 1 to bit 2.

In the MAC_FRAME_FILTER register, set the HMC bit (bit 2) to 1.

26.7.2 Power management block

This section describes the power management (PMT) mechanisms supported by the MAC. PMT supports the reception of network (remote) wake-up frames and Magic Packet frames. PMT does not perform the clock gate function, but generates interrupts for wake-up frames and Magic Packets received by the MAC. The PMT block sits on the receiver path of the MAC and is enabled with remote wake-up frame enable and Magic Packet enable. These enables are in the PMT Control and Status register and are programmed by the Application.

When the power-down mode is enabled in the PMT, then all received frames are dropped by the core and they are not forwarded to the application. The core comes out of the power down mode only when either a Magic Packet or a Remote Wake-up frame is received and the corresponding detection is enabled.

26.7.2.1 Remote wake-up frame registers

The register WKUPFMFILTER_REG, address (0x028), loads the Wake-up Frame Filter register. To load values in a Wake-up Frame Filter register, the entire register (WKUPFMFILTER_REG) must be written. The WKUPFMFILTER_REG register is loaded by sequentially loading the eight register values in address (0x028) for WKUPFMFILTER_REG0, WKUPFMFILTER_REG1,... WKUPFMFILTER_REG7, respectively. WKUPFMFILTER_REG is read in the same way.

Remark: The internal counter to access the appropriate WKUPFMFILTER_REG is incremented when lane 3 (or lane 0 in big-endian) is accessed by the CPU. This should be kept in mind if you are accessing these registers in byte or half-word mode.

WKUPFMFILTER0	Filter 0 Byte Mask							
WKUPFMFILTER1	Filter 1 Byte Mask							
WKUPFMFILTER2	Filter 2 Byte Mask							
WKUPFMFILTER3	Filter 3 Byte Mask							
WKUPFMFILTER4	RSVD	Filter 3 Command	RSVD	Filter 2 Command	RSVD	Filter 1 Command	RSVD	Filter 0 Command
WKUPFMFILTER5	Filter 3 Offset		Filter 2 Offset		Filter 1 Offset		Filter 0 Offset	
WKUPFMFILTER6	Filter 1 CRC - 16				Filter 0 CRC - 16			
WKUPFMFILTER7	Filter 3 CRC - 16				Filter 2 CRC - 16			

Fig 68. Wake-up frame filter register

Filter i byte mask

This register defines which bytes of the frame are examined by filter i (0, 1, 2, and 3) in order to determine whether or not the frame is a wake-up frame. The MSB (thirty-first bit) must be zero. Bit j [30:0] is the Byte Mask. If bit j (byte number) of the Byte Mask is set, then Filter i Offset + j of the incoming frame is processed by the CRC block; otherwise Filter i Offset + j is ignored.

Filter i command

This 4-bit command controls the filter i operation. Bit 3 specifies the address type, defining the pattern’s destination address type. When the bit is set, the pattern applies to only multicast frames; when the bit is reset, the pattern applies only to unicast frame. Bit 2 and Bit 1 are reserved. Bit 0 is the enable for filter i; if Bit 0 is not set, filter i is disabled.

Filter i offset

This register defines the offset (within the frame) from which filter i examines the frames. This 8-bit pattern offset is the offset for the filter i first byte to be examined. The minimum allowed is 12, which refers to the 13th byte of the frame. The offset value 0 refers to the first byte of the frame.

Filter i CRC-16

This register contains the CRC_16 value calculated from the pattern, as well as the byte mask programmed to the wake-up filter register block.

26.7.2.2 Remote wake-up detection

When the MAC is in sleep mode and the remote wake-up bit is enabled in PMT Control and Status register (0x002C), normal operation is resumed after receiving a remote wake-up frame. The Application writes all eight wake-up filter registers by performing a sequential Write to address (0x0028). The Application enables remote wake-up by writing a 1 to Bit 2 of the PMT Control and Status register.

PMT supports four programmable filters that allow support of different receive frame patterns. If the incoming frame passes the address filtering of Filter Command, and if Filter CRC-16 matches the incoming examined pattern, then the wake-up frame is received.

Filter_offset (minimum value 12, which refers to the 13th byte of the frame) determines the offset from which the frame is to be examined. Filter Byte Mask determines which bytes of the frame must be examined. The thirty-first bit of Byte Mask must be set to zero.

The remote wake-up CRC block determines the CRC value that is compared with Filter CRC-16. The wake-up frame is checked only for length error, FCS error, dribble bit error, MII error, collision, and to ensure that it is not a runt frame. Even if the wake-up frame is more than 512 bytes long, if the frame has a valid CRC value, it is considered valid. Wake-up frame detection is updated in the PMT Control and Status register for every remote Wake-up frame received. A PMT interrupt to the Application triggers a Read to the PMT Control and Status register to determine reception of a wake-up frame.

26.7.2.3 Magic packet detection

The Magic Packet frame is based on a method that uses Advanced Micro Device's Magic Packet technology to power up the sleeping device on the network. The MAC receives a specific packet of information, called a Magic Packet, addressed to the node on the network.

Only Magic Packets that are addressed to the device or a broadcast address will be checked to determine whether they meet the wake-up requirements. Magic Packets that pass the address filtering (unicast or broadcast) will be checked to determine whether they meet the remote Wake-on-LAN data format of 6 bytes of all ones followed by a MAC Address appearing 16 times.

The application enables Magic Packet wake-up by writing a 1 to Bit 1 of the PMT Control and Status register. The PMT block constantly monitors each frame addressed to the node for a specific Magic Packet pattern. Each frame received is checked for a 0xFFFF FFFF FFFF pattern following the destination and source address field. The PMT block then checks the frame for 16 repetitions of the MAC address without any breaks or interruptions. In case of a break in the 16 repetitions of the address, the 0xFFFF FFFF FFFF pattern is scanned for again in the incoming frame. The 16 repetitions can be anywhere in the frame, but must be preceded by the synchronization stream (0xFFFF FFFF FFFF). The device will also accept a multicast frame, as long as the 16 duplications of the MAC address are detected.

If the MAC address of a node is 0x0011 2233 4455, then the MAC scans for the data sequence:

```
00 11 22 33 44 55 00 11 22 33 44 55 00 11 22 33 44 55 00 11 22 33 44 55
00 11 22 33 44 55 00 11 22 33 44 55 00 11 22 33 44 55 00 11 22 33 44 55
00 11 22 33 44 55 00 11 22 33 44 55 00 11 22 33 44 55 00 11 22 33 44 55
00 11 22 33 44 55 00 11 22 33 44 55 00 11 22 33 44 55 00 11 22 33 44 55
...CRC
```

Magic Packet detection is updated in the PMT Control and Status register for Magic Packet received. A PMT interrupt to the Application triggers a read to the PMT CSR to determine whether a Magic Packet frame has been received.

26.7.2.4 System considerations during power-down

MAC neither gates nor stops clocks when Power-down mode is enabled. Power saving by clock gating must be done outside the core by the application. The receive data path must be clocked with ENET_RX_CLK during Power-down mode because it is involved in magic packet/wake-on-LAN frame detection. However, the transmit path and the application path clocks can be gated off during Power-down mode.

The PMT interrupt is asserted when a valid wake-up frame is received. This signal is generated in the receive clock domain

The recommended power-down and wake-up sequence is as follows.

1. Disable the Transmit DMA and wait for any previous frame transmissions to complete. These transmissions can be detected when Transmit Interrupt (see DMA_STAT register bit NIS; [Table 557](#)) is received.
2. Disable the MAC transmitter and MAC receiver by clearing the appropriate bits in the MAC Configuration register.
3. Wait until the Receive DMA empties all the frames from the Rx FIFO (a software timer may be required).
4. Enable Power-Down mode by appropriately configuring the PMT registers.
5. Enable the MAC Receiver and enter Power-Down mode.
6. Gate the application and transmit clock inputs to the core (and other relevant clocks in the system) to reduce power and enter Sleep mode.
7. On receiving a valid wake-up frame, the MAC PMT interrupt signal and exits Power-Down mode.
8. On receiving the interrupt, the system must enable the application and transmit clock inputs to the core.
9. Read the PMT Status register to clear the interrupt, then enable the other modules in the system and resume normal operation.

Remark:

26.7.3 DMA arbiter functions

If you have enabled the transmit (Tx) DMA and receive (Rx) DMA of a channel, you can specify which DMA gets the bus when the channel gets the control of the bus. You can set the priority between the corresponding Tx DMA and Rx DMA by using the bit 27 (TXPR: Transmit Priority) of the DMA Bus Mode Register). For round-robin arbitration, you can use the bits [15:14] (PR: Priority Ratio) of the Bus Mode Register to specify the weighted priority between the Tx DMA and Rx DMA. [Table 566](#) provides information about the priority scheme between Tx DMA and Rx DMA.

Table 566. Priority scheme for transmit and receive DMA

Bit 27	Bit 15	Bit 14	Bit 1	Priority scheme
0	x	x	x	Rx always has priority over Tx
0	0	0	0	Tx and Rx have equal priority. Rx gets the access first on simultaneous requests.
0	0	1	0	Rx has priority over Tx in the ratio 2:1.
0	1	0	0	Rx has priority over Tx in the ratio 3:1.

Table 566. Priority scheme for transmit and receive DMA

Bit 27	Bit 15	Bit 14	Bit 1	Priority scheme
0	1	1	0	Rx has priority over Tx in the ratio 4:1.
1	x	x	1	Tx always has priority over Rx.
1	0	0	0	Tx and Rx have equal priority. Tx gets the access first on simultaneous requests.
1	0	1	0	Tx has priority over Rx in the ratio 2:1.
1	1	0	0	Tx has priority over Rx in the ratio 3:1.
1	1	1	0	Tx has priority over Rx in the ratio 4:1.

26.7.4 IEEE 1588-2002 timestamps

The IEEE 1588-2002 standard defines a protocol, Precision Time Protocol (PTP), that enables precise synchronization of clocks in measurement and control systems implemented with technologies such as network communication, local computing, and distributed objects. The PTP applies to systems communicating by local area networks supporting multicast messaging, including (but not limited to) Ethernet. This protocol enables heterogeneous systems that include clocks of varying inherent precision, resolution, and stability to synchronize. The protocol supports system-wide synchronization accuracy in the sub-microsecond range with minimal network and local clock computing resources.

The PTP is transported over UDP/IP. The system or network is classified into Master and Slave nodes for distributing the timing/clock information. [Figure 69](#) shows the process that PTP uses for synchronizing a slave node to a master node by exchanging PTP messages.

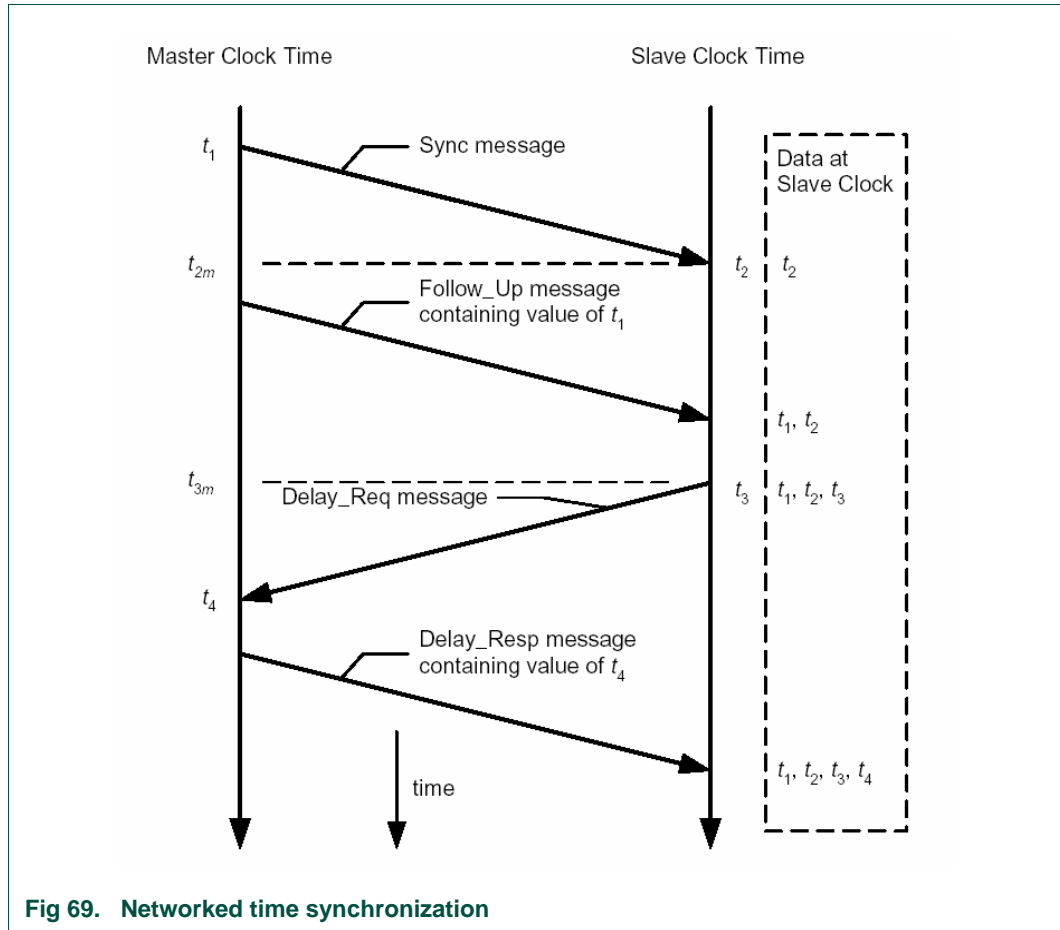

Fig 69. Networked time synchronization

As shown in [Figure 69](#), the PTP uses the following process:

1. The master broadcasts the PTP Sync messages to all its nodes. The Sync message contains the master's reference time information. The time at which this message leaves the master's system is t_1 . This time must be captured, for Ethernet ports, at MII.
2. The slave receives the Sync message and also captures the exact time, t_2 , using its timing reference.
3. The master sends a Follow_up message to the slave, which contains t_1 information for later use.
4. The slave sends a Delay_Req message to the master, noting the exact time, t_3 , at which this frame leaves the MII.
5. The master receives the message, capturing the exact time, t_4 , at which it enters its system.
6. The master sends the t_4 information to the slave in the Delay_Resp message.
7. The slave uses the four values of t_1, t_2, t_3 , and t_4 to synchronize its local timing reference to the master's timing reference.

Most of the PTP implementation is done in the software above the UDP layer. However, the hardware support is required to capture the exact time when specific PTP packets enter or leave the Ethernet port at the MII. This timing information must be captured and returned to the software for the proper implementation of PTP with high accuracy.

26.7.4.1 Reference timing source

To get a snapshot of the time, the MAC requires a reference time in 64-bit format as defined in the IEEE 1588 specification. The Ethernet MAC uses internal timing to provide a reference timing source by using the reference clock input to generate the Reference time (also called the System Time) internally and capture timestamps. The generation, update, and modification of the System Time are described in [Section 26.7.4.2](#).

26.7.4.2 System time register module

The 64-bit time is maintained in this module and updated using the input reference clock. This time is the source for taking snapshots (timestamps) of Ethernet frames being transmitted or received at the MII.

The System Time counter can be initialized or corrected using the coarse correction method. In this method, the initial value or the offset value is written to the Timestamp Update register ([Table 539](#)). For initialization, the System Time counter is written with the value in the

Timestamp Update registers, while for system time correction, the offset value is added to or subtracted from the system time. In the fine correction method, a slave clock's frequency drift with respect to the master clock (as defined in IEEE 1588) is corrected over a period of time instead of in one clock, as in coarse correction. This helps maintain linear time and does not introduce drastic changes (or a large jitter) in the reference time between PTP Sync message intervals. In this method, an accumulator sums up the contents of the Addend register, as shown in Figure 4-2. The arithmetic carry that the accumulator generates is used as a pulse to increment the system time counter. The accumulator and the addend are 32-bit registers. Here, the accumulator acts as a high-precision frequency multiplier or divider.

This algorithm is shown in [Figure 70](#):

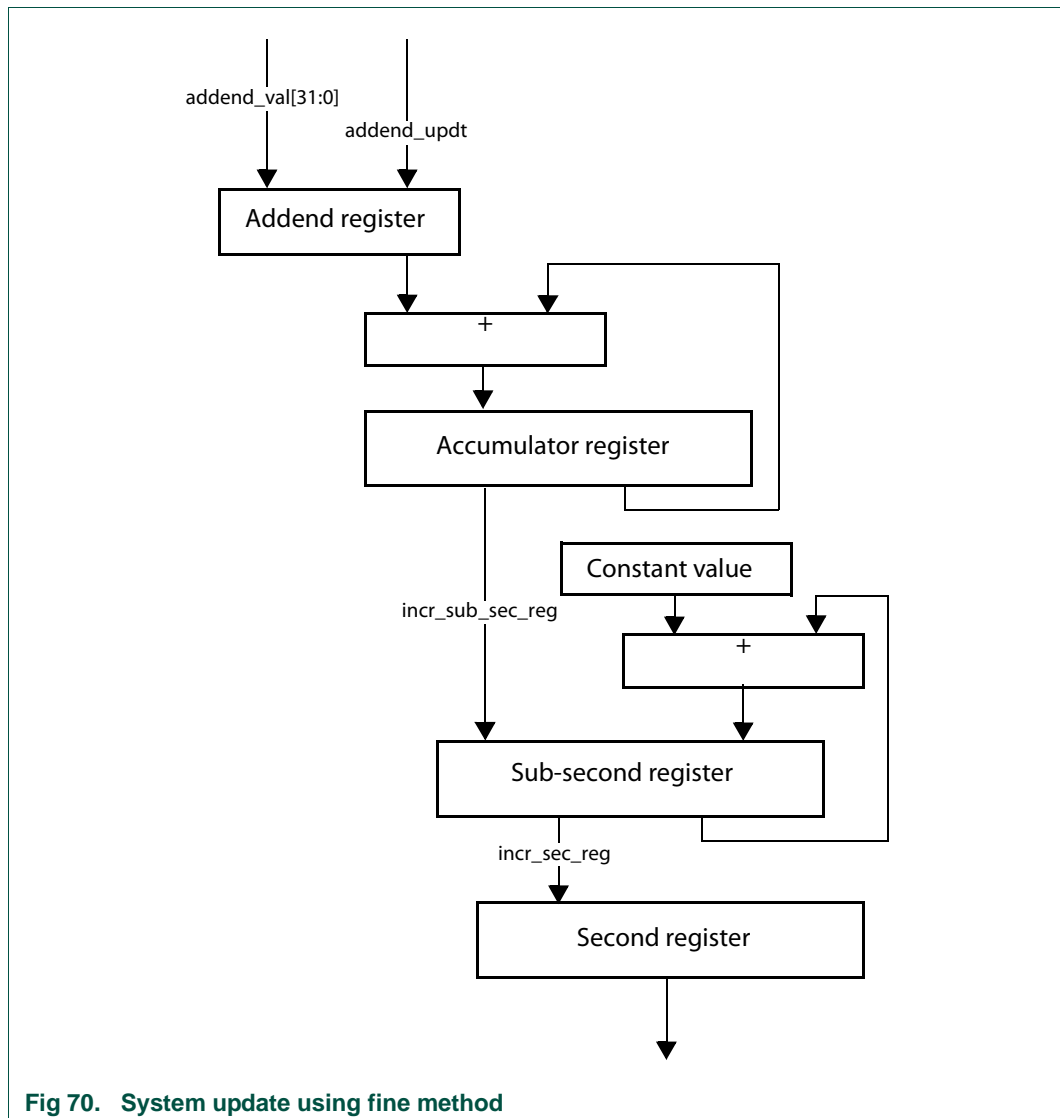

Fig 70. System update using fine method

The System Time Update logic requires a 50-MHz clock frequency to achieve 20-ns accuracy. The frequency division is the ratio of the reference clock frequency to the required clock frequency. Hence, if the reference clock is, for example, 66 MHz, this ratio is calculated as $66 \text{ MHz} / 50 \text{ MHz} = 1.32$. Hence, the default addend value to be set in the register is $2^{32} / 1.32$, 0xC1F07C1F.

If the reference clock drifts lower, to 65 MHz for example, the ratio is $65 / 50$, or 1.3 and the value to set in the addend register is $2^{32} / 1.30$, or 0xC4EC4EC4. If the clock drifts higher, to 67 MHz for example, the addend register must be set to 0xBF0B7672. When the clock drift is nil, the default addend value of 0xC1F07C1F ($2^{32} / 1.32$) must be programmed.

In [Figure 70](#), the constant value used to accumulate the sub-second register is decimal 43, which achieves an accuracy of 20 ns in the system time (in other words, it is incremented in 20-ns steps).

The software must calculate the drift in frequency based on the Sync messages and update the Addend register accordingly.

Initially, the slave clock is set with `FreqCompensationValue0` in the `Addend` register. This value is as follows:

$$\text{FreqCompensationValue0} = 232 / \text{FreqDivisionRatio}$$

If `MasterToSlaveDelay` is initially assumed to be the same for consecutive Sync messages, the algorithm described below must be applied. After a few Sync cycles, frequency lock occurs. The slave clock can then determine a precise `MasterToSlaveDelay` value and re-synchronize with the master using the new value.

The algorithm is as follows:

- At time `MasterSyncTimen` the master sends the slave clock a Sync message. The slave receives this message when its local clock is `SlaveClockTimen` and computes `MasterClockTimen` as:

$$\text{MasterClockTime}_n = \text{MasterSyncTime}_n + \text{MasterToSlaveDelay}_n$$
- The master clock count for current Sync cycle, `MasterClockCountn` is given by:

$$\text{MasterClockCount}_n = \text{MasterClockTime}_n - \text{MasterClockTime}_{n-1}$$
 (assuming that `MasterToSlaveDelay` is the same for Sync cycles `n` and `n - 1`)
- The slave clock count for current Sync cycle, `SlaveClockCountn` is given by:

$$\text{SlaveClockCount}_n = \text{SlaveClockTime}_n - \text{SlaveClockTime}_{n-1}$$
- The difference between master and slave clock counts for current Sync cycle, `ClockDiffCountn` is given by:

$$\text{ClockDiffCount}_n = \text{MasterClockCount}_n - \text{SlaveClockCount}_n$$
- The frequency-scaling factor for slave clock, `FreqScaleFactorn` is given by:

$$\text{FreqScaleFactor}_n = (\text{MasterClockCount}_n + \text{ClockDiffCount}_n) / \text{SlaveClockCount}_n$$
- The frequency compensation value for `Addend` register, `FreqCompensationValuen` is given by:

$$\text{FreqCompensationValue}_n = \text{FreqScaleFactor}_n * \text{FreqCompensationValue}_{n-1}$$

In theory, this algorithm achieves lock in one Sync cycle; however, it may take several cycles, because of changing network propagation delays and operating conditions.

This algorithm is self-correcting: if for any reason the slave clock is initially set to a value from the master that is incorrect, the algorithm corrects it at the cost of more Sync cycles.

26.7.4.3 Transmit path functions

The MAC captures a timestamp when the Start Frame Delimiter (SFD) of a frame is sent on MII. The frames for which you want to capture timestamps are controllable on a per-frame basis. In other words, each transmit frame can be marked to indicate whether a timestamp should be captured for that frame.

The MAC does not process the transmitted frames to identify the PTP frames. You need to specify the frames for which you want to capture timestamps.

Use the control bits in the transmit descriptor (see [Section 26.7.6.3.1](#)). The MAC returns the timestamp to the software inside the corresponding transmit descriptor, thus connecting the timestamp automatically to the specific PTP frame. The 64-bit timestamp information is written to the `TDES6` and `TDES7` fields. The `TDES7` field holds the 32 least significant bits of the timestamp.

26.7.4.4 Receive path functions

The MAC captures the timestamp of all frames received on the MII. The MAC does not process the received frames to identify the PTP frames in the default mode, that is, when the Advanced Timestamp feature is not selected.

The MAC gives the timestamp and the corresponding status on the MAC Receive Interface (MRI) along with the EOF data. The MAC transaction layer (MTL) provides the timestamp on the data bus after the EOF data has been transferred. The MTL sends a separate signal to validate the timestamp and to indicate the availability of the timestamp. Once the timestamp is transferred, the Status Valid signal is asserted as soon as status data is present on the data bus.

The DMA returns the timestamp to the software in the corresponding receive descriptor. The 64-bit timestamp information is written back to the RDES6 and RDES7 fields. The RDES2 holds the 32 least significant bits of the timestamp, except as mentioned in [Section 26.7.6.3.2](#). The timestamp is written only to that receive descriptor for which the Last Descriptor status field has been set to 1 (the EOF marker). When the timestamp is not available (for example, because of an RxFIFO overflow), an all-ones pattern is written to the descriptors (RDES6 and RDES7), indicating that timestamp is not correct. If the software uses a control register bit to disable time stamping, the DMA does not alter RDES6 or RDES7.

26.7.4.5 Timestamp error margin

According to the IEEE 1588 specifications, a timestamp must be captured at the SFD of the transmitted and received frames at the MII interface. Because the reference timing source (the PTP clock) is different from the MII clocks, a small error margin is introduced, because of the transfer of information across asynchronous clock domains.

In the transmit path, the captured and reported timestamp has a maximum error margin of 2 PTP clocks. It means that the captured timestamp has the reference timing source value that is given within 2 clocks after the SFD has been transmitted on the MII.

Similarly, in the receive path, the error margin is 3 MII clocks, plus up to 2 PTP clocks. You can ignore the error margin because of the II clocks by assuming that this constant delay is present in the system (or link) before the SFD data reaches the GMAC.s MII interface.

26.7.4.6 Frequency range of the reference timing clock

The timestamp information is transferred across asynchronous clock domains, that is, from MAC clock domain to application clock domain. Therefore, a minimum delay is required between two consecutive timestamp captures. This delay is 4 clock cycles of II and 3 clock cycles of PTP clocks. If the delay between two timestamp captures is less than this delay, the MAC does not take a timestamp snapshot for the second frame.

The maximum PTP clock frequency is limited by the maximum resolution of the reference time (1 ns resulting in 1 GHz) and the timing constraints achievable for logic operating on the PTP clock. In addition, the resolution, or granularity, of the reference time source determines the accuracy of the synchronization. Therefore, a higher PTP clock frequency gives better system performance.

The minimum PTP clock frequency depends on the time required between two consecutive SFD bytes. Because the MII clock frequency is fixed by IEEE specification, the minimum PTP clock frequency required for proper operation depends upon the operating mode and operating speed of the MAC as shown in Table 4-1.

Table 567. Minimum PTP clock frequency cycle

Mode	Minimum gap between two SFDs	Minimum PTP frequency
100-Mbps full-duplex operation	168 MII clocks (128 clocks for a 64-byte frame + 24 clocks of min IFG + 16 clocks of preamble)	$(3 * \text{PTP}) + (4 * \text{MII}) \leq 168 * \text{MII}$ that is, $\sim 0.5 \text{ MHz } ((168 - 4) * 40 \text{ ns} \div 3 = 2,180 \text{ ns period})$

26.7.5 IEEE 1588-2008 advanced timestamps

In addition to the basic timestamp features (see [Section 26.7.4](#)) the ethernet controller supports the following advanced timestamp features defined in the IEEE 1588-2008 standard:

- Supports the IEEE 1588-2008 (version 2) timestamp format.
- Provides an option to take snapshot of all frames or only PTP type frames.
- Provides an option to take snapshot of only event messages.
- Provides an option to take the snapshot based on the clock type: ordinary, boundary, end-to-end, and peer-to-peer.
- Provides an option to select the node to be a Master or Slave for ordinary and boundary clock.
- Identifies the PTP message type, version, and PTP payload in frames sent directly over Ethernet and sends the status.
- Provides an option to measure sub-second time in digital or binary format.

26.7.5.1 Peer-to-Peer PTP Transparent Clock (P2P TC) Message Support

The IEEE 1588-2008 version supports Peer-to-Peer PTP (Pdelay) message in addition to SYNC, Delay Request, Follow-up, and Delay Response messages. [Figure 71](#) shows the method to calculate the propagation delay in clocks supporting peer-to-peer path correction.

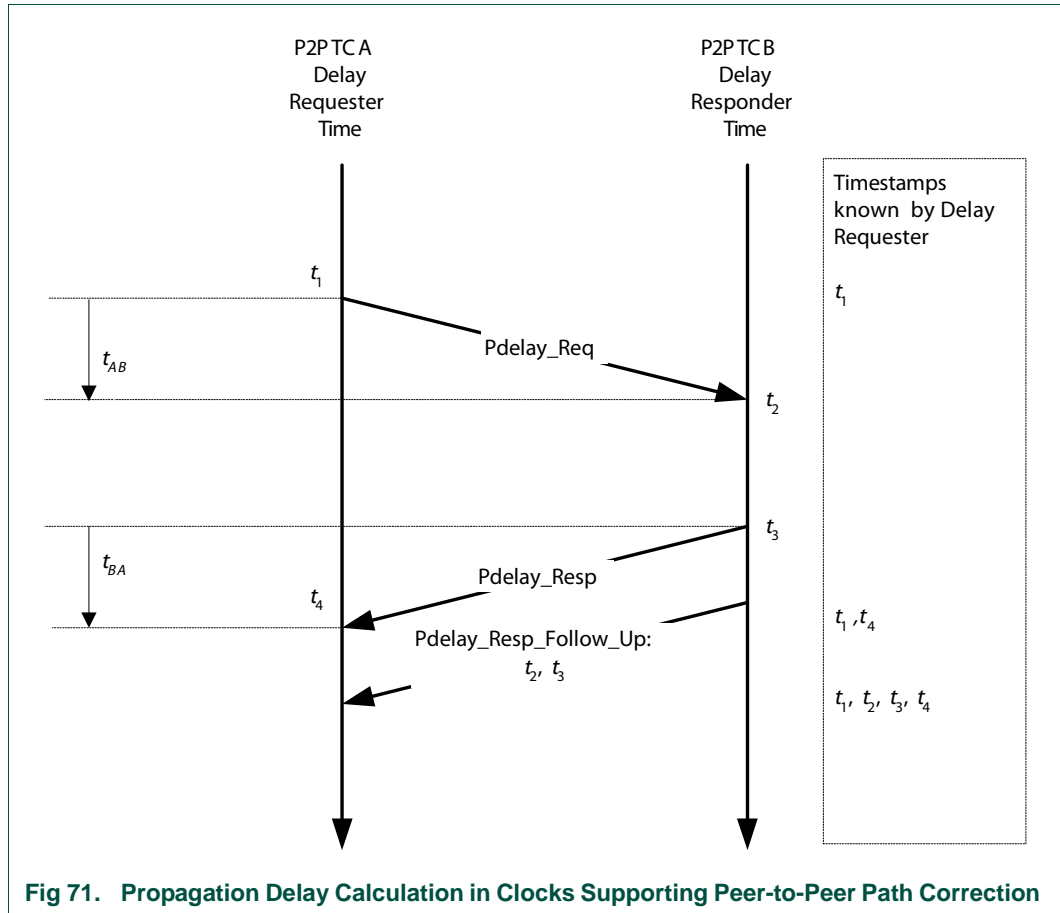

Fig 71. Propagation Delay Calculation in Clocks Supporting Peer-to-Peer Path Correction

As shown in [Figure 71](#), the propagation delay is calculated in the following way:

1. Port-1 issues a `Pdelay_Req` message and generates a timestamp, t_1 , for the `Pdelay_Req` message .
2. Port-2 receives the `Pdelay_Req` message and generates a timestamp, t_2 , for this message.
3. Port-2 returns a `Pdelay_Resp` message and generates a timestamp, t_3 , for this message.

To minimize errors because of any frequency offset between the two ports, Port-2 returns the `Pdelay_Resp` message as quickly as possible after the receipt of the `Pdelay_Req` message. The Port-2 returns any one of the following:

- The difference between the timestamps t_2 and t_3 in the `Pdelay_Resp` message.
- The difference between the timestamps t_2 and t_3 in the `Pdelay_Resp_Follow_Up` message.
- The timestamps t_2 and t_3 in the `Pdelay_Resp` and `Pdelay_Resp_Follow_Up` messages respectively.

4. Port-1 generates a timestamp, t_4 , on receiving the `Pdelay_Resp` message.
5. Port-1 uses all four timestamps to compute the mean link delay.

26.7.5.2 Clock types

The Ethernet controller supports the following clock types defined in the IEEE 1588-2008 standard:

- Ordinary clock
- Boundary clock
- End-to-end transparent clock
- Peer-to-peer transparent clock

26.7.5.2.1 Ordinary clock

The ordinary clock in a domain supports a single copy of the protocol. The ordinary clock has a single PTP state and a single physical port. In typical industrial automation applications, an ordinary clock is associated with an application device such as a sensor or an actuator. In telecommunications applications, the ordinary clock can be associated with a timing demarcation device.

The ordinary clock can be a grandmaster or a slave clock. The ordinary clock supports the following features:

- Send and receives PTP messages. The timestamp snapshot can be controlled as described in [Table 539](#).
- Maintains the data sets such as timestamp values.

Table 568. Ordinary clock: PTP messages for snapshot

Master	Slave
Delay_Req	SYNC

For an ordinary clock, you can take the snapshot of either one of the following PTP message types: version 1 or version 2. You cannot take the snapshots for both PTP message types. You can take the snapshot by setting the control bit (TSVER2ENA) and selecting the snapshot mode in [Table 539](#).

26.7.5.2.2 Boundary clock

The boundary clock typically has several physical ports communicating with the network. The messages related to synchronization, master-slave hierarchy, and signaling terminate in the protocol engine of the boundary clock and are not forwarded. The PTP message type status given by the core (see [Section 26.7.4.4](#)) helps you to identify the type of message and take appropriate action.

The boundary clock is similar to the ordinary clock except for the following features:

- The clock data sets are common to all ports of the boundary clock .
- The local clock is common to all ports of the boundary clock.

Therefore, the features of the ordinary clock are also applicable to the boundary clock.

26.7.5.2.3 End-to-end transparent clock

The end-to-end transparent clock supports the end-to-end delay measurement mechanism between slave clocks and the master clock. The end-to-end transparent clock forwards all messages like normal bridge, router, or repeater. The residence time of a PTP packet is the time taken by the PTP packet from the Ingress port to the Egress port.

The residence time of a SYNC packet inside the end-to-end transparent clock is updated in the correction field of the associated Follow_Up PTP packet before it is transmitted. Similarly, the residence time of a Delay_Req packet inside the end-to-end transparent clock is updated in the correction field of the associated Delay_Resp PTP packet before it is transmitted. Therefore, the snapshot needs to be taken at both Ingress and Egress ports only for the messages mentioned in [Table 569](#).

You can take the snapshot by setting the snapshot select bits (SNAPTYPSEL) to 10 in [Table 539](#).

Table 569. End-to-end transparent clock: PTP messages for which a snapshot is taken for transparent clock implementation

SYNC
FOLLOW_UP

26.7.5.2.4 Peer-to-peer transparent clock support

In this type of clock the computation of the link delay is based on an exchange of Pdelay_Req, Pdelay_Resp and Pdelay_Resp_Follow_Up messages with the link peer. Hence support for taking snapshot for the event messages related to Pdelay is added.

Table 570. End-to-end transparent clock: PTP messages for which a snapshot is taken for transparent clock implementation

SYNC
Pdelay_Req
Pdelay_Resp

The transparent clock corrects only the SYNC and Follow-up message. As discussed earlier this can be achieved using the message status provided.

The type of clock to be implemented will be configurable through control register (see [Table 539](#)). To ensure that the snapshot is taken only for the messages indicated in the table for the corresponding clock type, the.TSEVNTENA: Enable Time Stamp Snapshot for Event Messages. bit has to be set.

26.7.5.3 PTP processing and control

Table 4-5 shows the common message header for the PTP messages. This format is taken from IEEE standard 1588-2008 (Revision of IEEE Std. 1588-2002).

Table 571. Message format defined in IEEE 1588-2008

Bits								OCTETS	OFFSET
7	6	5	4	3	2	1	0		
transportSpecific				messageType				1	0
Reserved				versionPTP				1	1
				messageLength				2	2
				domainNumber				1	4
				Reserved				1	5
				flagField				2	6
				correctionField				8	8
				Reserved				4	16
				sourcePortIdentity				10	20

Table 571. Message format defined in IEEE 1588-2008

Bits								OCTETS	OFFSET
7	6	5	4	3	2	1	0		
sequenceld								2	30
controlField (1)								1	32
logMessageInterva								1	33

[1] Field is used in version 1. In version 2, messageType field is used for detecting different message types.

There are some fields in the Ethernet payload that you can use to detect the PTP packet type and control the snapshot to be taken. These fields are different for the following PTP frames:

- PTP Frames Over IPv4
- PTP Frames Over IPv6
- PTP Frames Over Ethernet

26.7.5.3.1 PTP frames over IPv4

Table 4-6 provides information about the fields that are matched to control snapshot for the PTP packets sent over UDP over IPv4 for IEEE 1588 version 1 and 2. The octet positions for the tagged frames are offset by 4. This is based on Annex D of IEEE 1588-2008 standard and the message format defined in [Table 569](#).

Table 572. IPv4-UDP PTP Frame Fields Required for Control and Status

Field Matched	Octet Position	Matched Value	Description
MAC Frame Type	12, 13	0x0800	IPv4 datagram
IP version and Header Length	14	0x45	IP version is IPv4
Layer 4 Protocol	23	0x11	UDP
IP Multicast Address (IEEE 1588 version 1)	30, 31, 32, 33	0xE0, 0x00, 0x01, 0x81 (or 0x82 or 0x83 or 0x84)	Multicast IPv4 addresses allowed. 224.0.1.129 224.0.1.130 224.0.1.131 224.0.1.132
IP Multicast Address (IEEE 1588 version 2)	30, 31, 32, 33	0xE0, 0x00, 0x01, 0x81 (Hex) 0xE0, 0x00, 0x00, 0x6B (Hex)	PTP-Primary multicast address: 224.0.1.129 PTP-Pdelay multicast address: 224.0.0.107
UDP Destination Port	36, 37	0x013F, 0x0140	0x013F – PTP event message (1) 0x0140 – PTP general messages

Table 572. IPv4-UDP PTP Frame Fields Required for Control and Status

Field Matched	Octet Position	Matched Value	Description
PTP Control Field (IEEE version 1)	74	0x00/0x01/0x02/ 0x03/0x04	0x00 – SYNC, 0x01 – Delay_Req 0x02 – Follow_Up 0x03 – Delay_Resp 0x04 – Management
PTP Message Type Field (IEEE version 2)	42 (nibble)	0x0/0x1/0x2/0x3/ 0x8/0x9/0xB /0xC/0xD	0x0 – SYNC 0x1 – Delay_Req 0x2 – Pdelay_Req 0x3 – Pdelay_Resp 0x8 – Follow_Up 0x9 – Delay_Resp 0xA – Pdelay_Resp_Follow_Up 0xB – Announce 0xC – Signaling 0xD – Management
PTP Version	43 (nibble)	0x1 or 0x2	0x1 – Supports PTP version 1 0x2 – Supports PTP version 2

[1] PTP event messages are SYNC, Delay_Req (IEEE 1588 version 1 and 2) or Pdelay_Req, Pdelay_Resp (IEEE 1588 version 2 only).

26.7.5.3.2 PTP Frames Over IPv6

[Table 573](#) provides information about the fields that are matched to control the snapshots for the PTP packets sent over UDP over IPv6 for IEEE 1588 version 1 and 2. The octet positions for the tagged frames are offset by 4. This is based on Annex D of IEEE 1588-2008 standard and the message format defined in [Table 569](#).

Table 573. IPv6-UDP PTP Frame Fields Required for Control and Status

Field Matched	Octet Position	Matched Value	Description
MAC Frame Type	12, 13	0x86DD	IP datagram
IP version	14(bits [7:4])	0x6	IP version is IPv6
Layer 4 Protocol	20 (U)	0x11	UDP
PTP Multicast Address	38 – 53	FF0x:0:0:0:0:0:0: 181 (Hex) FF02:0:0:0:0:0:0: 6B (Hex)	PTP – Primary multicast address: FF0x:0:0:0:0:0:0:181 (Hex) PTP – Pdelay multicast address: FF02:0:0:0:0:0:0:6B (Hex)
UDP Destination Port	56, 57 (U)	0x013F, 0x140	0x013F – PTP event message 0x0140 – PTP general messages

Table 573. IPv6-UDP PTP Frame Fields Required for Control and Status

Field Matched	Octet Position	Matched Value	Description
PTP Control Field (IEEE version 1)	93 [1]	0x00/0x01/0x02/ 0x03/0x04	0x00 – SYNC 0x01 – Delay_Req 0x02 – Follow_Up 0x03 – Delay_Resp 0x04 – Management (version1)
PTP Message Type Field (IEEE version 2)	74 [1] (nibble)	0x0/0x1/0x2/0x3/ 0x8/0x9/0xB /0xC/0xD	0x0 – SYNC 0x1 – Delay_Req 0x2 – Pdelay_Req 0x3 – Pdelay_Resp 0x8 – Follow_Up 0x9 – Delay_Resp 0xA – Pdelay_Resp_Follow_Up 0xB – Announce 0xC – Signaling 0xD – Management
PTP Version	75 (nibble)	0x1 or 0x2	0x1 – Supports PTP version 1 0x2 – Supports PTP version 2

[1] The Extension Header is not defined for PTP packets.

26.7.5.3.3 PTP frames over ethernet

Table 4-8 provides information about the fields that are matched to control the snapshots for the PTP packets sent over Ethernet for IEEE 1588 version 1 and 2. The octet positions for the tagged frames are offset by 4. This is based on Annex D of the IEEE 1588-2008 standard and the message format defined in [Table 571](#).

Table 574. Ethernet PTP Frame Fields Required for Control And Status

Field Matched	Octet Position	Matched Value	Description
MAC Destination Multicast Address [1]	0-5	01-1B-19-00-00-00 01-80-C2-00-00-0E	All PTP messages can use any of the following multicast addresses [2] : 01-1B-19-00-00-00 01-80-C2-00-00-0E [3]
MAC Frame Type	12, 13	0x88F7	PTP Ethernet frame
PTP Control Field (IEEE version 1)	45	0x00/0x01/0x02/ 0x03/0x04	0x00 – SYNC 0x01 – Delay_Req 0x02 – Follow_Up 0x03 – Delay_Resp 0x04 – Management
PTP Message Type Field (IEEE version 2)	14 (nibble)	0x0/0x1/0x2/0x3/ 0x8/0x9/0xB /0xC/0xD	0x0 – SYNC 0x1 – Delay_Req 0x2 – Pdelay_Req 0x3 – Pdelay_Resp 0x8 – Follow_Up 0x9 – Delay_Resp 0xA – Pdelay_Resp_Follow_Up 0xB – Announce 0xC – Signaling 0xD – Management
PTP Version	14 (nibble)	0x1 or 0x2	0x1 – Supports PTP version 1 0x2 – Supports PTP version 2

- [1] The address match of destination addresses (DA) programmed in MAC address 1 to 31 is used if the control bit 18 (TSENMACADDR: Enable MAC address for PTP frame filtering) of the Timestamp Control register is set.
- [2] IEEE standard 1588-2008, Annex F
- [3] The Ethernet controller does not consider the PTP version 1 messages with Peer delay multicast address (01-80-C2-00-00-0E) as valid PTP messages.

26.7.5.4 Reference timing source

The ethernet controller supports the 48-bit seconds field reference timing sources featured in the IEEE 1588-2008 standard.

26.7.5.4.1 48-bit seconds field

The ethernet controller supports 80-bit timestamping. The timestamp has the following fields:

- UInteger48 secondsField

The seconds field is the integer portion of the timestamp in units of seconds and is 48-bits wide. For example, 2.000000001 seconds are represented as secondsField = 0x0000_0000_0002.

- UInteger32 nanosecondsField

The nanoseconds field is the fractional portion of the timestamp in units of nanoseconds. For example, 2.000000001 nanoseconds are represented as nanoSeconds = 0x0000_0001.

The nanoseconds field supports the following two modes:

- Digital rollover mode: In digital rollover mode, the maximum value in the nanoseconds field is 0x3B9A_C9FF, that is, (10e9-1) nanoseconds.
- Binary rollover mode: In binary rollover mode, the nanoseconds field rolls over and increments the seconds field after value 0x7FFF_FFFF. Accuracy is ~0.466 ns per bit.

You can set these modes by using the bit 9 (TSCTRLSSR) of [Table 539](#).

When you select the advanced timestamp feature, the timestamp maintained in the core is still 64-bit wide. The overflow to the upper 16-bits of seconds register happens once in 130 years. You can read the values of the upper 16-bits of the seconds field from the CSR register.

26.7.5.5 Transmit path functions

There is no change in the transmit path functions for the Advanced timestamp feature.

The structure of the descriptor changes when you enable the advanced timestamp feature. The advanced timestamp feature is supported only through Alternate (Enhanced) descriptors format. The descriptor is 32-bytes long (8 DWORDS) and the snapshot of the timestamp is written in descriptor TDES6 and TDES7. For detailed information about descriptors, see [Section 26.7.6.3](#).

26.7.5.6 Receive path functions

When you select the advanced timestamp feature, the MAC processes the received frames to identify valid PTP frames. You can control the snapshot of the time, to be sent to the application, by using the following options of the timestamp control register

([Section 26.6.16](#)):

- When you select the advanced timestamp feature, the MAC processes the received frames to identify valid PTP frames. You can control the snapshot of the time, to be sent to the application, by using the following options of the Timestamp Control Register.
- When you select the advanced timestamp feature, the MAC processes the received frames to identify valid PTP frames. You can control the snapshot of the time, to be sent to the application, by using the following options of Register 448 (Timestamp Control Register).
- Enable snapshot for PTP frames transmitted directly over Ethernet or UDP-IP-Ethernet.
- Enable timestamp snapshot for the received frame for IPv4 or IPv6.
- Enable timestamp snapshot for EVENT messages (SYNC, DELAY_REQ, PDELAY_REQ or PDELAY_RESP) only.
- Enable the node to be a Master or Slave and select the snapshot type. This controls the type of messages for which snapshots are taken.

Remark: The ethernet controller also supports PTP messages over VLAN frames.

The MAC provides the timestamp, along with EOF. An additional signal validates the presence of timestamp for the receive frame.

The MTL provides the timestamp on the data bus after the EOF data has been transferred. An additional signal validates the timestamp. This signal is asserted to indicate the availability of timestamp. Once the timestamp is transferred, the MTL sends the receive status to the application. In 32-bit datawidth mode, the MTL provides the additional status related to the timestamp on the data bus after the normal status is read. The additional status is provided only when the bit 0 of the normal status is set and is validated.

The DMA returns the timestamp to the software inside the corresponding Transmit and Receive Descriptor. The advanced timestamp feature is supported only with the 32-bytes long Alternate (Enhanced) descriptor. The extended status, containing the timestamp message status and the IPC status, is written in descriptor RDES4 and the snapshot of the timestamp is written in descriptors RDES6 and RDES7. For detailed information about descriptors, see [Section 26.7.6.3](#).

26.7.6 DMA controller description

The DMA has independent Transmit and Receive engines and a CSR space. The Transmit engine transfers data from system memory to the device port (MTL), while the Receive engine transfers data from the device port to the system memory. The controller uses descriptors to efficiently move data from source to destination with minimal Host CPU intervention. The DMA is designed for packet-oriented data transfers such as frames in Ethernet. The controller can be programmed to interrupt the Host CPU for situations such as Frame Transmit and Receive transfer completion, and other normal/error conditions.

The DMA and the Host driver communicate through two data structures:

- Control and Status registers (CSR). See [Section 26.6](#).

- Descriptor lists and data buffers. See [Section 26.7.6.3](#).

The DMA transfers data frames received by the core to the Receive Buffer in the Host memory, and Transmit data frames from the Transmit Buffer in the Host memory. Descriptors that reside in the Host memory act as pointers to these buffers. There are two descriptor lists; one for reception, and one for transmission. The base address of each list is written into DMA Registers [Table 555](#) and [Table 556](#). A descriptor list is forward linked (either implicitly or explicitly). The last descriptor may point back to the first entry to create a ring structure. Explicit chaining of descriptors is accomplished by setting the second address chained in both Receive and Transmit descriptors (RDES1[24] and TDES1[24]). The descriptor lists resides in the Host physical memory address space. Each descriptor can point to a maximum of two buffers. This enables two buffers to be used, physically addressed, rather than contiguous buffers in memory.

A data buffer resides in the Host physical memory space, and consists of an entire frame or part of a frame, but cannot exceed a single frame. Buffers contain only data, buffer status is maintained in the descriptor. Data chaining refers to frames that span multiple data buffers. However, a single descriptor cannot span multiple frames. The DMA skips to the next frame buffer when end-of-frame is detected. Data chaining can be enabled or disabled.

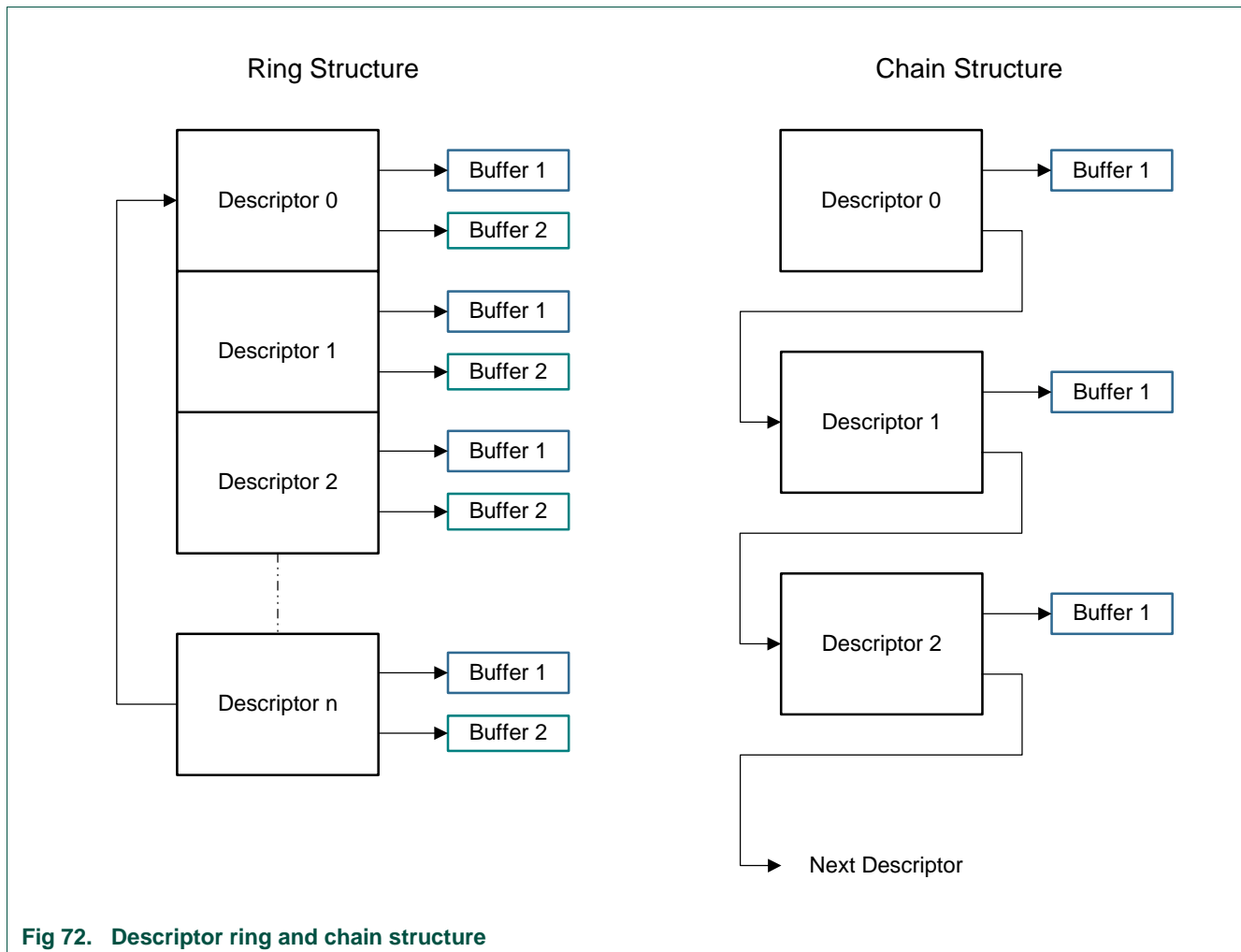

Fig 72. Descriptor ring and chain structure

26.7.6.1 Initialization

Follow these steps to initialize the ethernet controller:

1. Write to DMA Register [Table 551](#) to set Host bus access parameters.
2. Write to DMA Register [Table 559](#) to mask unnecessary interrupt causes.
3. The software driver creates the Transmit and Receive descriptor lists. Then it writes to both DMA Register [Table 555](#) and DMA Register [Table 556](#), providing the DMA with the starting address of each list.
4. Write to MAC Registers [Table 524](#), [Table 526](#), and [Table 525](#) for desired filtering options.
5. Write to MAC Register [Table 523](#) to configure the operating mode and enable the transmit operation (bit 3: Transmitter Enable). The PS and DM bits are set based on the auto-negotiation result (read from the PHY).
6. Write to DMA Register [Table 558](#) to set bits 13 and 1 to start transmission and reception.
7. Write to MAC Register [Table 523](#) to enable the Receive operation (bit 2: Receiver Enable).

The Transmit and Receive engines enter the Running state and attempt to acquire descriptors from the respective descriptor lists. The Receive and Transmit engines then begin processing Receive and Transmit operations. The Transmit and Receive processes are independent of each other and can be started or stopped separately.

26.7.6.1.1 Host bus burst access

The DMA attempts to execute fixed-length Burst transfers on the AHB Master interface if configured to do so (FB bit of DMA Register 0). The maximum Burst length is indicated and limited by the PBL field (DMA Register 0[13:8]). The Receive and Transmit descriptors are always accessed in the maximum possible (limited by PBL or 16 x 8/bus width) burst-size for the 16-bytes to be read.

The Transmit DMA initiates a data transfer only when sufficient space to accommodate the configured burst is available in MTL Transmit FIFO or the number of bytes till the end of frame (when it is less than the configured burst-length). The DMA indicates the start address and the number of transfers required to the AHB Master Interface. When the AHB Interface is configured for fixed-length burst, then it transfers data using the best combination of INCR4/8/16 and SINGLE transactions. Otherwise (no fixed-length burst), it transfers data using INCR (undefined length) and SINGLE transactions.

The Receive DMA initiates a data transfer only when sufficient data to accommodate the configured burst is available in MTL Receive FIFO or when the end of frame (when it is less than the configured burst-length) is detected in the Receive FIFO. The DMA indicates the start address and the number of transfers required to the AHB Master Interface. When the AHB Interface is configured for fixed-length burst, then it transfers data using the best combination of INCR4/8/16 and SINGLE transactions. If the end-of frame is reached before the fixed-burst ends on the AHB interface, then dummy transfers are performed in order to complete the fixed-burst. Otherwise (FB bit of DMA Register [Table 551](#) is reset), it transfers data using INCR (undefined length) and SINGLE transactions.

When the AHB interface is configured for address-aligned beats, both DMA engines ensure that the first burst transfer the AHB initiates is less than or equal to the size of the configured PBL. Thus, all subsequent beats start at an address that is aligned to the configured PBL. The DMA can only align the address for beats up to size 16 (for PBL > 16), because the AHB interface does not support more than INCR16.

26.7.6.1.2 Host data buffer alignment

The Transmit and Receive data buffers do not have any restrictions on start address alignment. For example, in systems with 32-bit memory, the start address for the buffers can be aligned to any of the four bytes. However, the DMA always initiates transfers with address aligned to the bus width with dummy data for the byte lanes not required. This typically happens during the transfer of the beginning or end of an Ethernet frame.

Example: Buffer read

If the Transmit buffer address is 0x0000FF2 (for 32-bit data bus), and 15 bytes need to be transferred, then the DMA reads five full words from address 0x0000FF0, but when transferring data to the MTL Transmit FIFO, the extra bytes (the first two bytes) are dropped or ignored. Similarly, the last 3 bytes of the last transfer are also ignored. The DMA always ensures it transfers a full 32-bit data to the MTL Transmit FIFO, unless it is the end-of-frame.

Example: Buffer write

If the Receive buffer address is 0x0000FF2 (for 64-bit data bus) and 16 bytes of a received frame need to be transferred, then the DMA writes 3 full words from address 0x0000FF0. But the first 2 bytes of first transfer and the last 6 bytes of the third transfer have dummy data.

26.7.6.1.3 Buffer size calculations

The DMA does not update the size fields in the Transmit and Receive descriptors. The DMA updates only the status fields (RDES and TDES) of the descriptors. The driver has to perform the size calculations.

The transmit DMA transfers the exact number of bytes (indicated by buffer size field of TDES1) towards the MAC core. If a descriptor is marked as first (FS bit of TDES1 is set), then the DMA marks the first transfer from the buffer as the start of frame. If a descriptor is marked as last (LS bit of TDES1), then the DMA marks the last transfer from that data buffer as the end-of frame to the MTL.

The Receive DMA transfers data to a buffer until the buffer is full or the end-of frame is received from the MTL. If a descriptor is not marked as last (LS bit of RDES0), then the descriptor's corresponding buffer(s) are full and the amount of valid data in a buffer is accurately indicated by its buffer size field minus the data buffer pointer offset when the FS bit of that descriptor is set. The offset is zero when the data buffer pointer is aligned to the data bus width. If a descriptor is marked as last, then the buffer may not be full (as indicated by the buffer size in RDES1). To compute the amount of valid data in this final buffer, the driver must read the frame length (FL bits of RDES0[29:16]) and subtract the sum of the buffer sizes of the preceding buffers in this frame. The Receive DMA always transfers the start of next frame with a new descriptor.

Remark: Even when the start address of a receive buffer is not aligned to the system bus's data width, the system should allocate a receive buffer of a size aligned to the system bus width. For example, if the system allocates a 1,024-byte (1 KB) receive buffer

starting from address 0x1000, the software can program the buffer start address in the Receive descriptor to have a 0x1002 offset. The Receive DMA writes the frame to this buffer with dummy data in the first two locations (0x1000 and 0x1001). The actual frame is written from location 0x1002. Thus, the actual useful space in this buffer is 1,022 bytes, even though the buffer size is programmed as 1,024 bytes, because of the start address offset.

26.7.6.1.4 DMA arbiter

The arbiter inside the DMA module performs the arbitration between the Transmit and Receive channel accesses to the AHB Master interface. Two types of arbitrations are possible: round-robin, and fixed-priority.

When round-robin arbitration is selected (DA bit of Register [Table 551](#) (Bus Mode Register) is reset), the arbiter allocates the data bus in the ratio set by the PR bits of DMA Register [Table 551](#), when both Transmit and Receive DMAs are requesting for access simultaneously. When the DA bit is set, the Receive DMA always gets priority over the Transmit DMA for data access by default. When the TXPR bit (bit 27 of DMA register [Table 551](#)) is also set, then the Transmit DMA gets priority over the Receive DMA.

26.7.6.2 Transmission

26.7.6.2.1 TxDMA operation: Default (non-OSF) mode

The transmit DMA engine in default mode proceeds as follows:

1. The Host sets up the transmit descriptor (TDES0-TDES3) and sets the Own bit (TDES0[31]) after setting up the corresponding data buffer(s) with Ethernet Frame data.
2. Once the ST bit (DMA Register) is set, the DMA enters the Run state.
3. While in the Run state, the DMA polls the Transmit Descriptor list for frames requiring transmission. After polling starts, it continues in either sequential descriptor ring order or chained order. If the DMA detects a descriptor flagged as owned by the Host, or if an error condition occurs, transmission is suspended and both the Transmit Buffer Unavailable (DMA Register [Table 557](#)) and Normal Interrupt Summary (DMA Register [Table 557](#)) bits are set. The Transmit Engine proceeds to Step 9.
4. If the acquired descriptor is flagged as owned by DMA (TDES0[31] = 1), the DMA decodes the Transmit Data Buffer address from the acquired descriptor.
5. The DMA fetches the Transmit data from the Host memory and transfers the data to the MTL for transmission.
6. If an Ethernet frame is stored over data buffers in multiple descriptors, the DMA closes the intermediate descriptor and fetches the next descriptor. Steps 3, 4, and 5 are repeated until the end-of-Ethernet-frame data is transferred to the MTL.
7. When frame transmission is complete, if IEEE 1588 time stamping was enabled for the frame (as indicated in the transmit status) the timestamp value obtained from MTL is written to the transmit descriptor (TDES2 and TDES3) that contains the end-of-frame buffer. The status information is then written to this transmit descriptor (TDES0). Because the Own bit is cleared during this step, the Host now owns this descriptor. If time stamping was not enabled for this frame, the DMA does not alter the contents of TDES2 and TDES3.

8. Transmit Interrupt (DMA Register [Table 557](#)) is set after completing transmission of a frame that has Interrupt on Completion (TDES1[31]) set in its Last Descriptor. The DMA engine then returns to Step 3.
9. In the Suspend state, the DMA tries to re-acquire the descriptor (and thereby return to Step 3) when it receives a Transmit Poll demand and the Underflow Interrupt Status bit is cleared.

The TxDMA transmission flow in default mode is shown in [Figure 73](#).

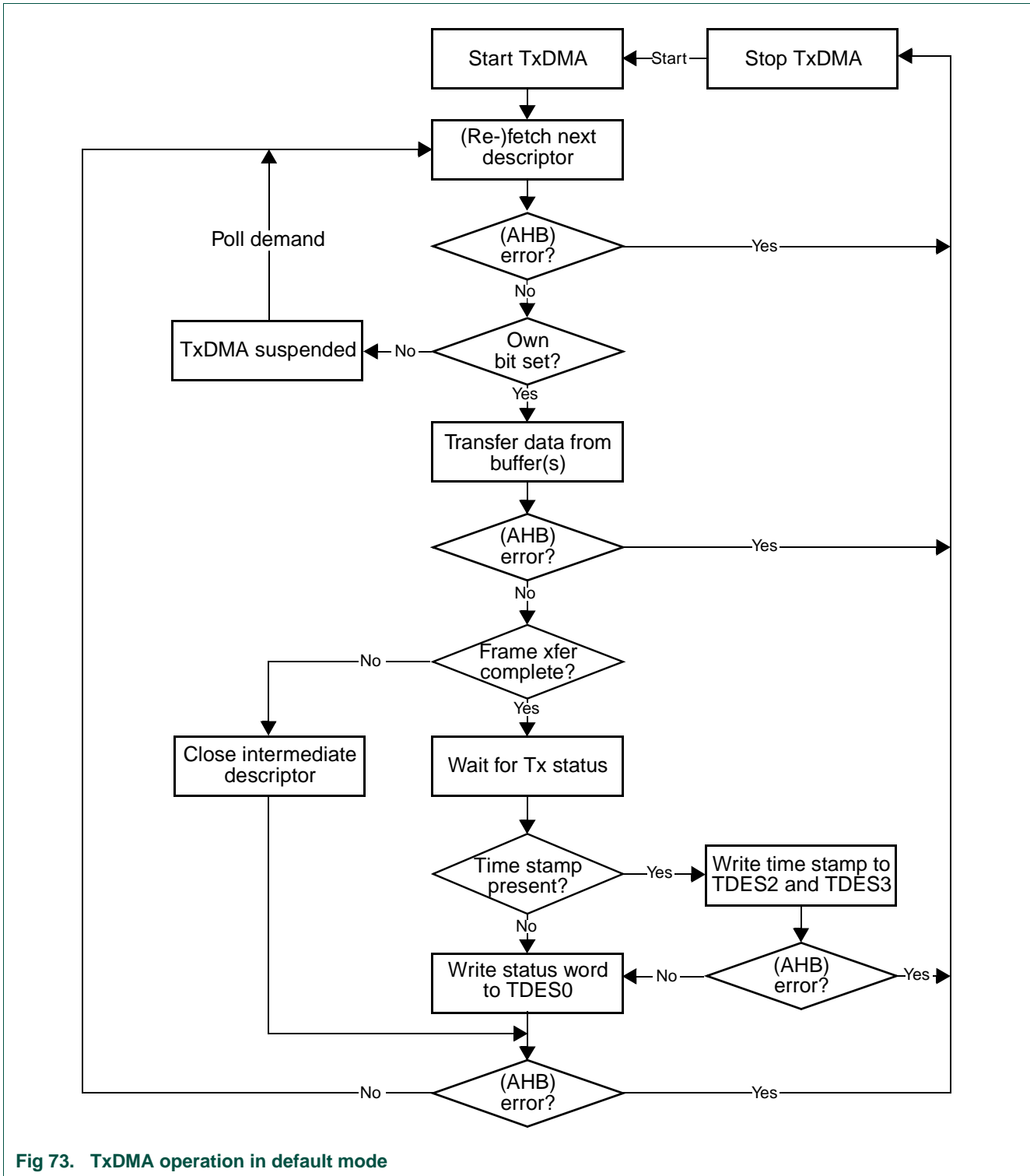

Fig 73. TxDMA operation in default mode

26.7.6.2.2 TxDMA operation: OSF mode

While in the Run state, the transmit process can simultaneously acquire two frames without closing the Status descriptor of the first (if the OSF bit is set in DMA Operation mode register, bit 2). As the transmit process finishes transferring the first frame, it

immediately polls the Transmit Descriptor list for the second frame. If the second frame is valid, the transmit process transfers this frame before writing the first frame's status information.

In OSF mode, the Run state Transmit DMA operates in the following sequence:

1. The DMA operates as described in steps 1 to 6 of the TxDMA (default mode).
2. Without closing the previous frame's last descriptor, the DMA fetches the next descriptor.
3. If the DMA owns the acquired descriptor, the DMA decodes the transmit buffer address in this descriptor. If the DMA does not own the descriptor, the DMA goes into Suspend mode and skips to Step 7.
4. The DMA fetches the Transmit frame from the Host memory and transfers the frame to the MTL until the End-of-Frame data is transferred, closing the intermediate descriptors if this frame is split across multiple descriptors.
5. The DMA waits for the previous frame's frame transmission status and time stamp. Once the status is available, the DMA writes the time stamp to TDES2 and TDES3, if such time stamp was captured (as indicated by a status bit). The DMA then writes the status, with a cleared Own bit, to the corresponding TDES0, thus closing the descriptor. If time stamping was not enabled for the previous frame, the DMA does not alter the contents of TDES2 and TDES3.
6. If enabled, the Transmit interrupt is set, the DMA fetches the next descriptor, then proceeds to Step 3 (when Status is normal). If the previous transmission status shows an underflow error, the DMA goes into Suspend mode (Step 7).
7. In Suspend mode, if a pending status and time stamp are received from the MTL, the DMA writes the time stamp (if enabled for the current frame) to TDES2 and TDES3, then writes the status to the corresponding TDES0. It then sets relevant interrupts and returns to Suspend mode.
8. The DMA can exit Suspend mode and enter the Run state (go to Step 1 or Step 2 depending on pending status) only after receiving a Transmit Poll demand (DMA Transmit Poll Demand register).

Remark: As the DMA fetches the next descriptor in advance before closing the current descriptor, the descriptor chain should have more than 2 different descriptors for correct and proper operation.

The basic flow is described in [Figure 74](#).

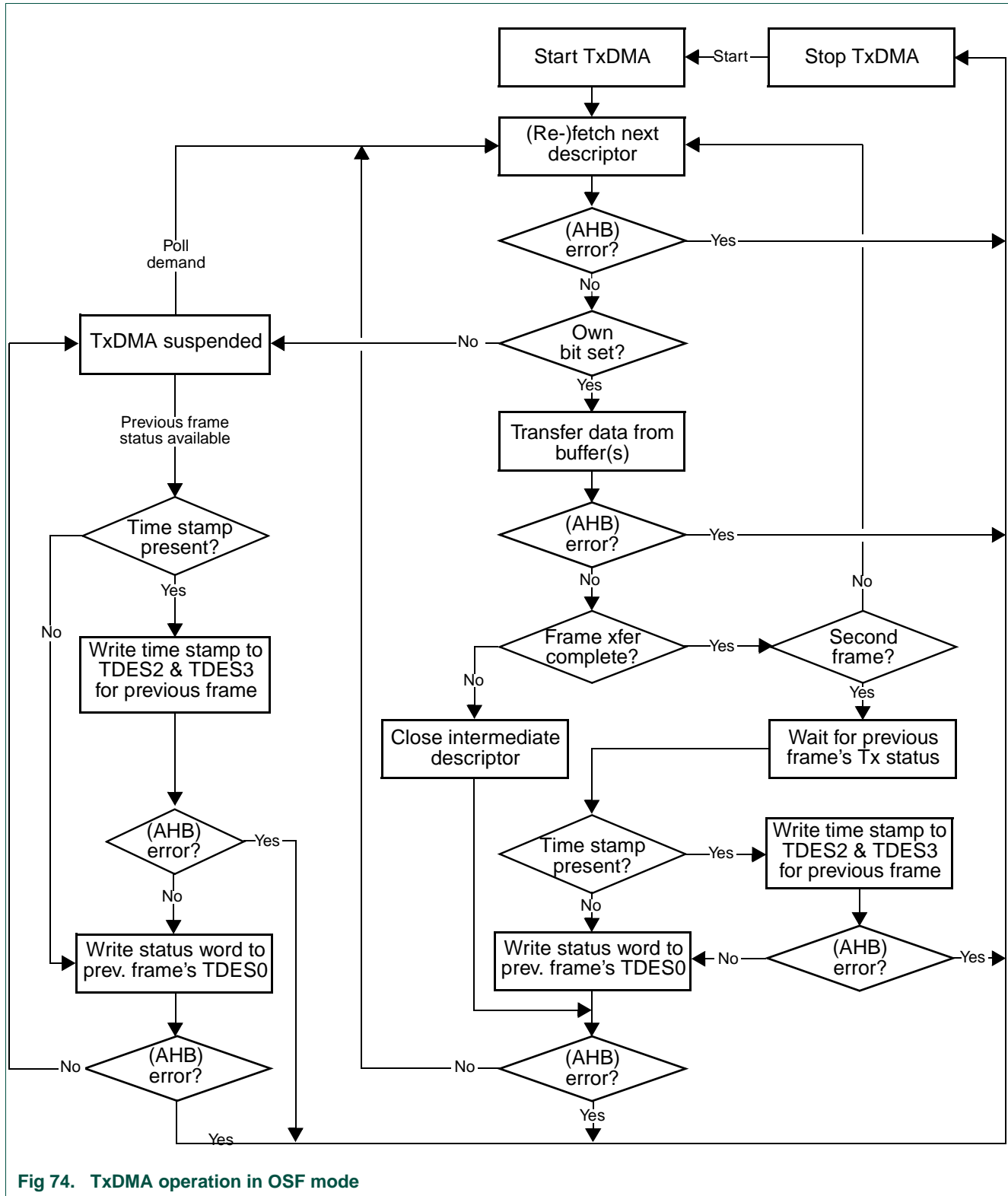

Fig 74. TxDMA operation in OSF mode

26.7.6.2.3 Transmit frame processing

The Transmit DMA expects that the data buffers contain complete Ethernet frames, excluding preamble, pad bytes, and FCS fields. The DA, SA, and Type/Len fields contain valid data. If the Transmit Descriptor indicates that the MAC core must disable CRC or PAD insertion, the buffer must have complete Ethernet frames (excluding preamble), including the CRC bytes.

Frames can be data-chained and can span several buffers. Frames must be delimited by the First Descriptor (TDES1[29]) and the Last Descriptor (TDES1[30]), respectively.

As transmission starts, the First Descriptor must have (TDES1[29]) set. When this occurs, frame data transfers from the Host buffer to the MTL Transmit FIFO. Concurrently, if the current frame has the Last Descriptor (TDES1[30]) clear, the Transmit Process attempts to acquire the Next Descriptor. The Transmit Process expects this descriptor to have TDES1[29] clear. If TDES1[30] is clear, it indicates an intermediary buffer. If TDES1[30] is set, it indicates the last buffer of the frame.

After the last buffer of the frame has been transmitted, the DMA writes back the final status information to the Transmit Descriptor 0 (TDES0) word of the descriptor that has the last segment set in Transmit Descriptor 1 (TDES1[30]). At this time, if Interrupt on Completion (TDES1[31]) was set, Transmit Interrupt (DMA Status register, bit 0) is set, the Next Descriptor is fetched, and the process repeats.

The actual frame transmission begins after the MTL Transmit FIFO has reached either a programmable transmit threshold (DMA Operation Mode register, bits [16:14]), or a full frame is contained in the FIFO. There is also an option for Store and Forward Mode (DMA Operation Mode register, bit [21]). Descriptors are released (Own bit TDES0[31] clears) when the DMA finishes transferring the frame.

Remark: To ensure proper transmission of a frame and the next frame, you must specify a non-zero buffer size for the transmit descriptor that has the Last Descriptor (TDES1[30]) set.

26.7.6.2.4 Transmit polling suspended

Transmit polling can be suspended by either of the following conditions:

- The DMA detects a descriptor owned by the Host (TDES0[31]=0). To resume, the driver must give descriptor ownership to the DMA and then issue a Poll Demand command.
- A frame transmission is aborted when a transmit error because of underflow is detected. The appropriate Transmit Descriptor 0 (TDES0) bit is set.

If the second condition occur, both Abnormal Interrupt Summary (DMA Status register [Table 557](#)) and Transmit Underflow bits (DMA Status register [Table 557](#)) are set, and the information is written to Transmit Descriptor 0, causing the suspension. If the DMA goes into SUSPEND state because of the first condition, then both Normal Interrupt Summary (DMA Status register [Table 557](#)) and Transmit Buffer Unavailable (DMA Status register [Table 557](#)) are set.

In both cases, the position in the Transmit List is retained. The retained position is that of the descriptor following the Last Descriptor closed by the DMA.

The driver must explicitly issue a Transmit Poll Demand command after rectifying the suspension cause.

26.7.6.2.5 Reception

The Receive DMA engine's reception sequence is shown in [Figure 75](#) and proceeds as follows:

1. The host sets up Receive descriptors (RDES0-RDES3) and sets the Own bit (RDES0[31]).
2. Once the SR (DMA Operation Mode register [Table 558](#)) bit is set, the DMA enters the Run state. While in the Run state, the DMA polls the Receive Descriptor list, attempting to acquire free descriptors. If the fetched descriptor is not free (is owned by the host), the DMA enters the Suspend state and jumps to Step 9.
3. The DMA decodes the receive data buffer address from the acquired descriptors.
4. Incoming frames are processed and placed in the acquired descriptor's data buffers.
5. When the buffer is full or the frame transfer is complete, the Receive engine fetches the next descriptor.
6. If the current frame transfer is complete, the DMA proceeds to Step 7. If the DMA does not own the next fetched descriptor and the frame transfer is not complete (EOF is not yet transferred), the DMA sets the Descriptor Error bit in the RDES0 (unless flushing is disabled). The DMA closes the current descriptor (clears the Own bit) and marks it as intermediate by clearing the Last Segment (LS) bit in the RDES0 value (marks it as Last Descriptor if flushing is not disabled), then proceeds to Step 8. If the DMA does own the next descriptor but the current frame transfer is not complete, the DMA closes the current descriptor as intermediate and reverts to Step 4.
7. If IEEE 1588 time stamping is enabled, the DMA writes the timestamp (if available) to the current descriptor's RDES2 and RDES3. It then takes the receive frame's status from the MTL and writes the status word to the current descriptor's RDES0, with the Own bit cleared and the Last Segment bit set.
8. The Receive engine checks the latest descriptor's Own bit. If the host owns the descriptor (Own bit is 0) the Receive Buffer Unavailable bit (DMA Status register [Table 557](#)) is set and the DMA Receive engine enters the Suspended state (Step 9). If the DMA owns the descriptor, the engine returns to Step 4 and awaits the next frame.
9. Before the Receive engine enters the Suspend state, partial frames are flushed from the Receive FIFO (You can control flushing using Bit 24 of DMA Operation Mode register [Table 558](#)).
10. The Receive DMA exits the Suspend state when a Receive Poll demand is given or the start of next frame is available from the MTL's Receive FIFO. The engine proceeds to Step 2 and refetches the next descriptor.

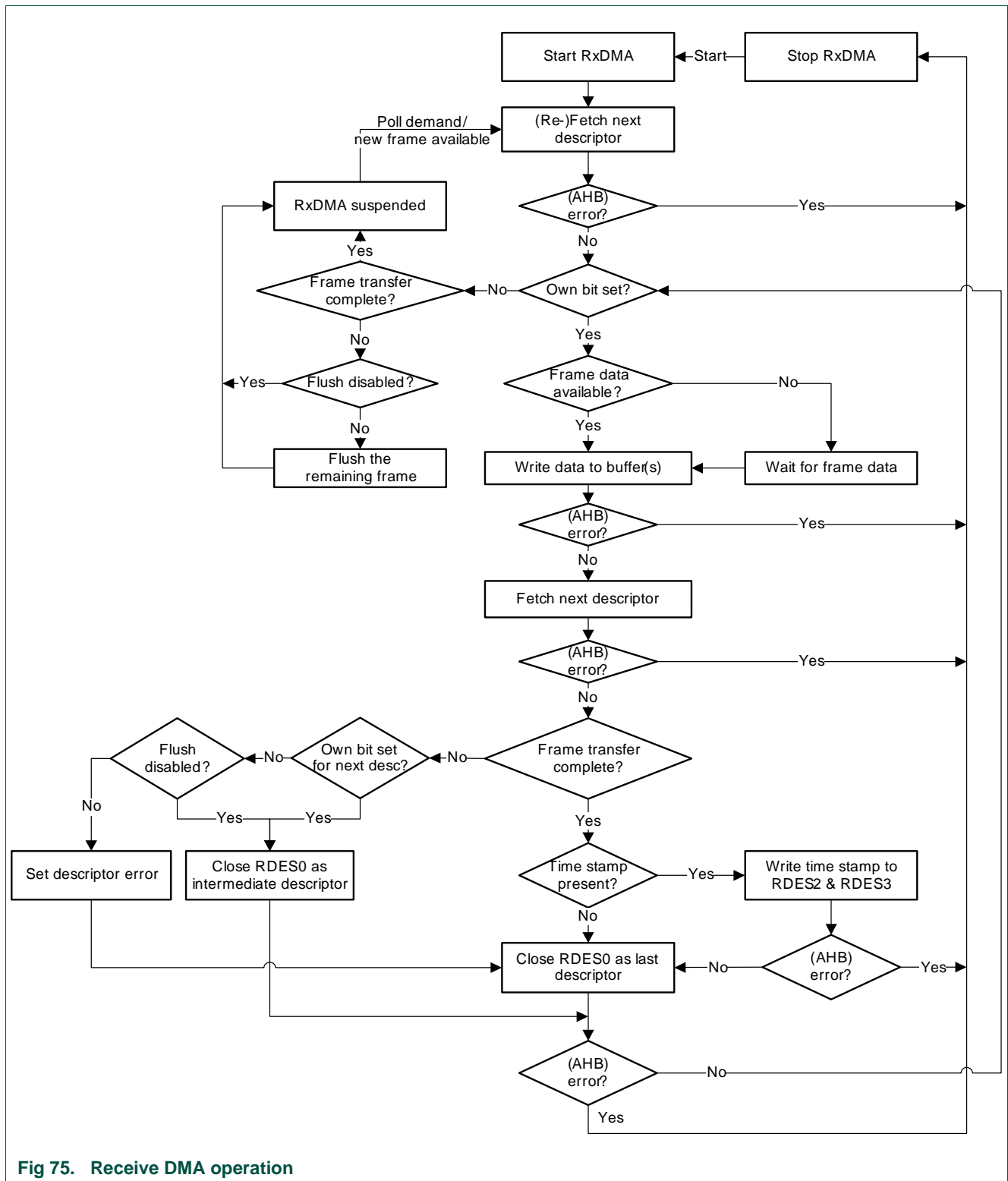

Fig 75. Receive DMA operation

The DMA does not acknowledge accepting the status from the MTL until it has completed the time stamp write-back and is ready to perform status write-back to the descriptor.

If software has enabled time stamping through CSR, when a valid time stamp value is not available for the frame (for example, because the receive FIFO was full before the time stamp could be written to it), the DMA writes all-ones to RDES2 and RDES3. Otherwise (that is, if time stamping is not enabled), the RDES2 and RDES3 remain unchanged.

26.7.6.2.6 Receive descriptor acquisition

The Receive Engine always attempts to acquire an extra descriptor in anticipation of an incoming frame. Descriptor acquisition is attempted if any of the following conditions is satisfied:

- The receive Start/Stop bit (DMA Operation Mode register [Table 558](#)) has been set immediately after being placed in the Run state.
- The data buffer of current descriptor is full before the frame ends for the current transfer.
- The controller has completed frame reception, but the current Receive Descriptor is not yet closed.
- The receive process has been suspended because of a host-owned buffer (RDES0[31] = 0) and a new frame is received.
- A Receive poll demand has been issued.

26.7.6.2.7 Receive frame processing

The MAC transfers the received frames to the Host memory only when the frame passes the address filter and frame size is greater than or equal to configurable threshold bytes set for the Receive FIFO of MTL, or when the complete frame is written to the FIFO in Store-and-Forward mode.

If the frame fails the address filtering, it is dropped in the MAC block itself (unless Receive All bit 31 is set in the MAC Frame Filter register; [Table 524](#)). Frames that are shorter than 64 bytes, because of collision or premature termination, can be purged from the MTL Receive FIFO.

After 64 (configurable threshold) bytes have been received, the MTL block requests the DMA block to begin transferring the frame data to the Receive Buffer pointed to by the current descriptor. The DMA sets First Descriptor (RDES0[9]) after the DMA Host Interface (AHB or MDC) becomes ready to receive a data transfer (if DMA is not fetching transmit data from the host), to delimit the frame. The descriptors are released when the Own (RDES[31]) bit is reset to 0, either as the Data buffer fills up or as the last segment of the frame is transferred to the Receive buffer. If the frame is contained in a single descriptor, both Last Descriptor (RDES[8]) and First Descriptor (RDES[9]) are set.

The DMA fetches the next descriptor, sets the Last Descriptor (RDES[8]) bit, and releases the RDES0 status bits in the previous frame descriptor. Then the DMA sets Receive Interrupt (Register 5[6]). The same process repeats unless the DMA encounters a descriptor flagged as being owned by the host. If this occurs, the Receive Process sets Receive Buffer Unavailable (DMA Status register [Table 557](#)) and then enters the Suspend state. The position in the receive list is retained.

26.7.6.2.8 Receive process suspended

If a new Receive frame arrives while the Receive Process is in Suspend state, the DMA refetches the current descriptor in the Host memory. If the descriptor is now owned by the DMA, the Receive Process re-enters the Run state and starts frame reception. If the

descriptor is still owned by the host, by default, the DMA discards the current frame at the top of the MTL Rx FIFO and increments the missed frame counter. If more than one frame is stored in the MTL Rx FIFO, the process repeats.

The discarding or flushing of the frame at the top of the MTL Rx FIFO can be avoided by setting Operation Mode register bit 24 (DFF) in [Table 558](#). In such conditions, the receive process sets the Receive Buffer Unavailable status and returns to the Suspend state.

26.7.6.2.9 Interrupts

Interrupts can be generated as a result of various events. The DMA Status register ([Table 557](#)) contains all the bits that might cause an interrupt. [Table 559](#) contains an enable bit for each of the events that can cause an interrupt.

There are two groups of interrupts, Normal and Abnormal, as described in DMA Status register ([Table 557](#)). Interrupts are cleared by writing a 1 to the corresponding bit position. When all the enabled interrupts within a group are cleared, the corresponding summary bit is cleared. When both the summary bits are cleared, the interrupt signal is de-asserted. If the MAC core is the cause for assertion of the interrupt, then any of the GLI, GMI, or GPI bits of DMA Status register ([Table 557](#)) are set HIGH.

Remark: The DMA Status register ([Table 557](#)) is the (interrupt) status register. The interrupt pin is asserted because of any event in this status register only if the corresponding interrupt enable bit is set in DMA Interrupt Enable Register ([Table 559](#)).

Interrupts are not queued and if the interrupt event occurs before the driver has responded to it, no additional interrupts are generated. For example, the Receive Interrupt (bit 6 of the DMA Status Register ([Table 557](#))) indicates that one or more frames were transferred to the Host buffer. The driver must scan all descriptors, from the last recorded position to the first one owned by the DMA.

An interrupt is generated only once for simultaneous, multiple events. The driver must scan the DMA Status register ([Table 557](#)) for the cause of the interrupt. The interrupt is not generated again unless a new interrupting event occurs, after the driver has cleared the appropriate bit in DMA Status register. For example, the controller generates a DMA Receive interrupt (bit 6 of the DMA Status register), and the driver begins reading DMA Status register. Next, Receive Buffer Unavailable (bit 7 of DMA Status register (Status Register)) occurs. The driver clears the Receive interrupt. Even then, the `sbd_intr_o` signal is not de-asserted, because of the active or pending Receive Buffer Unavailable interrupt.

An interrupt timer RIWT (bits 7:0 in Receive Interrupt Watchdog Timer Register ([Table 561](#))) is given for flexible control of Receive Interrupt. When this Interrupt timer is programmed with a non-zero value, it gets activated as soon as the RxDMA completes a transfer of a received frame to system memory without asserting the Receive Interrupt because it is not enabled in the corresponding Receive Descriptor (RDES1[31]). When this timer runs out as per the programmed value, RI bit is set and the interrupt is asserted if the corresponding RI is enabled in DMA Interrupt Enable register ([Table 559](#)). This timer gets disabled before it runs out, when a frame is transferred to memory and the RI is set because it is enabled for that descriptor.

26.7.6.2.10 Error response to DMA

For any data transfer initiated by a DMA channel, if the slave replies with an error response, that DMA stops all operations and updates the error bits and the Fatal Bus Error bit in the DMA Status register ([Table 557](#)). That DMA controller can resume operation only after soft resetting or hard resetting the core and re-initializing the DMA. This DMA behavior is true for non-AHB interfaced DMAs that receive an error response.

26.7.6.3 Ethernet descriptors

The descriptor structure supports up to 8 DWORDS (32 bytes) and the IEEE 1588-2008 Advanced Timestamp feature. The features of the descriptor structure are:

- Descriptor size can be 4 DWORDS (16 bytes) or 8 DWORDS (32 bytes) depending on the setting of the ATDS bit in the DMA Bus Mode register ([Table 551](#)).
- Support buffers of up to 8 KB (useful for Jumbo frames).
- The transmit descriptor stores the timestamp in TDES6 and TDES7 when you select the Advanced Timestamp.
- This receive descriptor structure is also used for storing the extended status (RDES4) and timestamp (RDES6 and RDES7) when advanced timestamp feature or IPC full offload is selected.
- When the descriptor mode is selected, and the Timestamp feature is enabled, the software needs to allocate 32-bytes (8 DWORDS) of memory for every descriptor. When Timestamping or Receive IPC FullOffload engine are not enabled, the extended descriptors are not required and the SW can use alternate descriptors with the default size of 16 bytes. The core also needs to be configured for this change using the bit 7 (ATDS: Alternate Descriptor Size) of DMA Bus Mode register ([Table 551](#)).
- When a descriptor is chosen without Timestamp or Full IPC Offload feature, the descriptor size is always 4 DWORDs (DES0-DES3).

26.7.6.3.1 Transmit descriptor

The transmit descriptor structure is shown in [Figure 76](#). The application software must program the control bits TDES0[31:20] during descriptor initialization. When the DMA updates the descriptor, it write backs all the control bits except the OWN bit (which it clears) and updates the status bits[19:0]. The contents of the transmitter descriptor word 0 (TDES0) through word 3 (TDES3) are given in [Table 575](#) through [Table 578](#), respectively.

With the advance timestamp support, the snapshot of the timestamp to be taken can be enabled for a given frame by setting bit TTSE: Transmit Timestamp Enable. (bit-25 of TDES0). When the descriptor is closed (i.e. when the OWN bit is cleared), the time-stamp is written into TDES6 and TDES7. This is indicated by the status bit TTSS: Transmit Timestamp Status. (bit-17 of TDES0). This is shown in [Figure 76](#). The contents of TDES6 and TDES7 are mentioned in [Table 579](#) to [Table 580](#).

When either Advanced Timestamp or IPC Offload (Type 2) features is enabled, the SW should set the DMA Bus Mode register[7], so that the DMA operates with extended descriptor size. When this control bit is reset, the TDES4-TDES7 descriptor space are not valid.

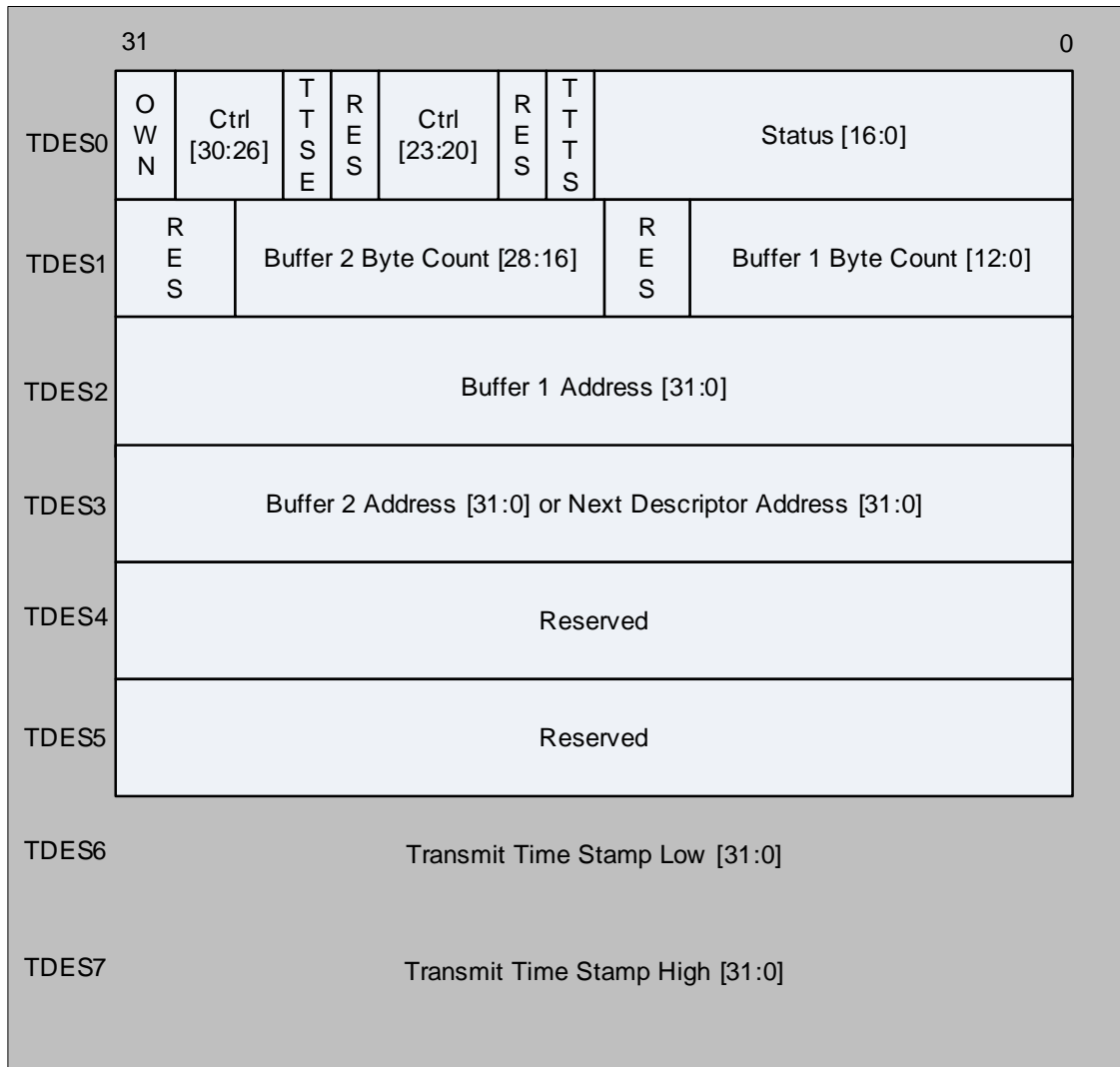

Fig 76. Transmitter descriptor fields

The DMA always reads or fetches four DWORDS of the descriptor from system memory to obtain the buffer and control information as shown in [Figure 77](#). When Advanced timestamp feature support is enabled, TDES0 has additional control bits[6:3] for channel 1 and channel 2. For channel 0, the bits 6:3 are ignored. The bits 6:3 are described in [Table 575](#).

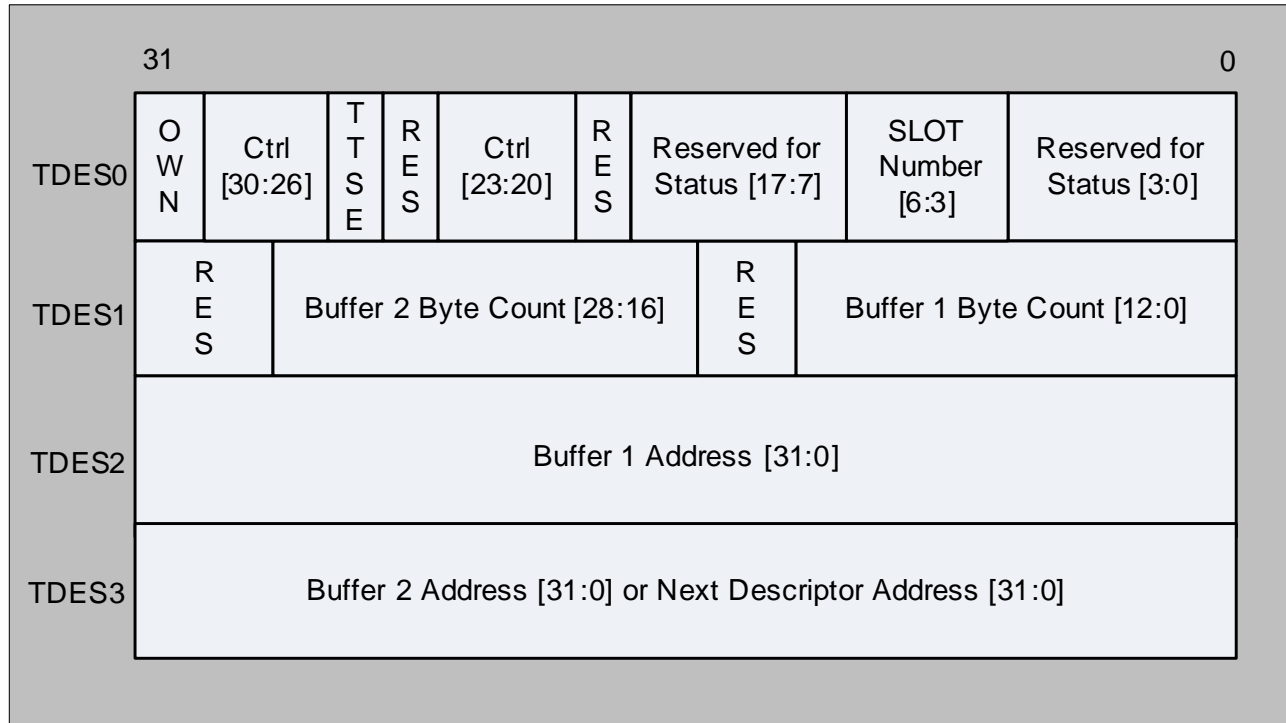

Fig 77. Transmit descriptor fetch (read)

Table 575. Transmit descriptor word 0 (TDES0)

Bit	Symbol	Description
0	DB	Deferred Bit When set, this bit indicates that the MAC defers before transmission because of the presence of carrier. This bit is valid only in Half-Duplex mode.
1	UF	Underflow Error When set, this bit indicates that the MAC aborted the frame because data arrived late from the Host memory. Underflow Error indicates that the DMA encountered an empty transmit buffer while transmitting the frame. The transmission process enters the Suspended state and sets both Transmit Underflow (Register 5[5]) and Transmit Interrupt (Register 5[0]).
2	ED	Excessive Deferral When set, this bit indicates that the transmission has ended because of excessive deferral of over 24,288 bit times (155,680 bits times in 1,000-Mbps mode or if Jumbo Frame is enabled) if the Deferral Check (DC) bit in the MAC Control register is set high.
6:3	CC/ SLOTNUM	CC: Collision Count (Status field) These status bits indicate the number of collisions that occurred before the frame was transmitted. This count is not valid when the Excessive Collisions bit (TDES0[8]) is set. The core updates this status field only in the half-duplex mode. SLOTNUM: Slot Number Control Bits in AV Mode These bits indicate the slot interval in which the data should be fetched from the corresponding buffers addressed by TDES2 or TDES3. When the transmit descriptor is fetched, the DMA compares the slot number value in this field with the slot interval maintained in the core . It fetches the data from the buffers only if there is a match in values. These bits are valid only for the AV channels (not channel 0).
7	VF	VLAN Frame When set, this bit indicates that the transmitted frame was a VLAN-type frame.

Table 575. Transmit descriptor word 0 (TDES0)

Bit	Symbol	Description
8	EC	Excessive Collision When set, this bit indicates that the transmission was aborted after 16 successive collisions while attempting to transmit the current frame. If the DR (Disable Retry) bit in the MAC Configuration register is set, this bit is set after the first collision, and the transmission of the frame is aborted.
9	LC	Late Collision When set, this bit indicates that frame transmission was aborted due to a collision occurring after the collision window (64 byte-times, including preamble, in MII mode and 512 byte-times, including preamble and carrier extension, in MII mode). This bit is not valid if the Underflow Error bit is set.
10	NC	No Carrier When set, this bit indicates that the Carrier Sense signal from the PHY was not asserted during transmission.
11	LC	Loss of Carrier When set, this bit indicates that a loss of carrier occurred during frame transmission. This is valid only for the frames transmitted without collision when the MAC operates in Half-Duplex mode.
12	IPE	IP Payload Error When set, this bit indicates that MAC transmitter detected an error in the TCP, UDP, or ICMP IP datagram payload. The transmitter checks the payload length received in the IPv4 or IPv6 header against the actual number of TCP, UDP, or ICMP packet bytes received from the application and issues an error status in case of a mismatch.
13	FF	Frame Flushed When set, this bit indicates that the DMA/MTL flushed the frame due to a software Flush command given by the CPU.
14	JT	Jabber Timeout When set, this bit indicates the MAC transmitter has experienced a jabber time-out. This bit is only set when the MAC configuration register's JD bit is not set.
15	ES	Error Summary Indicates the logical OR of the following bits: <ul style="list-style-type: none"> • TDES0[14]: Jabber Timeout • TDES0[13]: Frame Flush • TDES0[11]: Loss of Carrier • TDES0[10]: No Carrier • TDES0[9]: Late Collision • TDES0[8]: Excessive Collision • TDES0[2]: Excessive Deferral • TDES0[1]: Underflow Error • TDES0[16]: IP Header Error • TDES0[12]: IP Payload Error
16	IHE	IP Header Error When set, this bit indicates that the MAC transmitter detected an error in the IP datagram header. The transmitter checks the header length in the IPv4 packet against the number of header bytes received from the application and indicates an error status if there is a mismatch. For IPv6 frames, a header error is reported if the main header length is not 40 bytes. Furthermore, the Ethernet Length/Type field value for an IPv4 or IPv6 frame must match the IP header version received with the packet. For IPv4 frames, an error status is also indicated if the Header Length field has a value less than 0x5.
17	TTSS	Transmit Timestamp Status This field is used as a status bit to indicate that a timestamp was captured for the described transmit frame. When this bit is set, TDES2 and TDES3 have a timestamp value captured for the transmit frame. This field is only valid when the descriptor's Last Segment control bit (TDES0[29]) is set.
19:18	-	Reserved

Table 575. Transmit descriptor word 0 (TDES0)

Bit	Symbol	Description
20	TCH	Second Address Chained When set, this bit indicates that the second address in the descriptor is the Next Descriptor address rather than the second buffer address. When TDES0[20] is set, TBS2 (TDES1[28:16]) is a “don’t care” value. TDES0[21] takes precedence over TDES0[20].
21	TER	Transmit End of Ring When set, this bit indicates that the descriptor list reached its final descriptor. The DMA returns to the base address of the list, creating a descriptor ring.
23:22	-	Reserved
24	-	Reserved
25	TTSE	Transmit Timestamp Enable When set, this bit enables IEEE1588 hardware time stamping for the transmit frame referenced by the descriptor. This field is valid only when the First Segment control bit (TDES0[28]) is set.
26	DP	Disable Pad When set, the MAC does not automatically add padding to a frame shorter than 64 bytes. When this bit is reset, the DMA automatically adds padding and CRC to a frame shorter than 64 bytes, and the CRC field is added despite the state of the DC (TDES0[27]) bit. This is valid only when the first segment (TDES0[28]) is set.
27	DC	Disable CRC When this bit is set, the MAC does not append a cyclic redundancy check (CRC) to the end of the transmitted frame. This is valid only when the first segment (TDES0[28]) is set.
28	FS	First Segment When set, this bit indicates that the buffer contains the first segment of a frame.
29	LS	Last Segment When set, this bit indicates that the buffer contains the last segment of the frame. When this bit is set, the TBS1: Transmit Buffer 1 Size or TBS2: Transmit Buffer 2 Size field in TDES1 should have a non-zero value.
30	IC	Interrupt on Completion When set, this bit sets the Transmit Interrupt (Register 5[0]) after the present frame has been transmitted.
31	OWN	Own Bit When set, this bit indicates that the descriptor is owned by the DMA. When this bit is reset, it indicates that the descriptor is owned by the Host. The DMA clears this bit either when it completes the frame transmission or when the buffers allocated in the descriptor are read completely. The ownership bit of the frame’s first descriptor must be set after all subsequent descriptors belonging to the same frame have been set. This avoids a possible race condition between fetching a descriptor and the driver setting an ownership bit.

Table 576. Transmit descriptor word 1 (TDES1)

Bit	Symbol	Description
12:0	TBS1	Transmit buffer 1 size These bits indicate the first data buffer byte size, in bytes. If this field is 0, the DMA ignores this buffer and uses Buffer 2 or the next descriptor, depending on the value of TCH (TDES0[20]).
15:13	-	Reserved
28:16	TBS2	These bits indicate the second data buffer size in bytes. This field is not valid if TDES0[20] is set. See Section 26.7.6.1.3 .
31:29	-	Reserved

Table 577. Transmit descriptor word 2 (TDES2)

Bit	Symbol	Description
31:0	B1ADD	Buffer 1 Address Pointer These bits indicate the physical address of Buffer 1. There is no limitation on the buffer address alignment. See Section 26.7.6.1.2 for further detail on buffer address alignment.

Table 578. Transmit descriptor word 3 (TDES3)

Bit	Symbol	Description
31:0	B2ADD	Buffer 2 Address Pointer (Next Descriptor Address) Indicates the physical address of Buffer 2 when a descriptor ring structure is used. If the Second Address Chained (TDES1[24]) bit is set, this address contains the pointer to the physical memory where the Next Descriptor is present. The buffer address pointer must be aligned to the bus width only when TDES1[24] is set. (LSBs are ignored internally.)

Table 579. Transmit descriptor word 6 (TDES6)

Bit	Symbol	Description
31:0	TTSL	Transmit Frame Timestamp Low This field is updated by DMA with the least significant 32 bits of the timestamp captured for the corresponding transmit frame. This field has the timestamp only if the Last Segment bit (LS) in the descriptor is set and Timestamp status (TTSS) bit is set.

Table 580. Transmit descriptor word 7 (TDES7)

Bit	Symbol	Description
31:0	TTSH	Transmit Frame Timestamp High This field is updated by DMA with the most significant 32 bits of the timestamp captured for the corresponding receive frame. This field has the timestamp only if the Last Segment bit (LS) in the descriptor is set and Timestamp status (TTSS) bit is set.

26.7.6.3.2 Receive descriptor

The structure of the received descriptor is shown in [Figure 78](#). This can have 32 bytes of descriptor data (8 DWORDs) when Advanced Timestamp is selected.

Remark: The SW should set the DMA Bus Mode register[7] so that the DMA operates with extended descriptor size. When this control bit is reset, RDES0[7] and RDES0[0] is always cleared and the RDES4-RDES7 descriptor space are not valid.

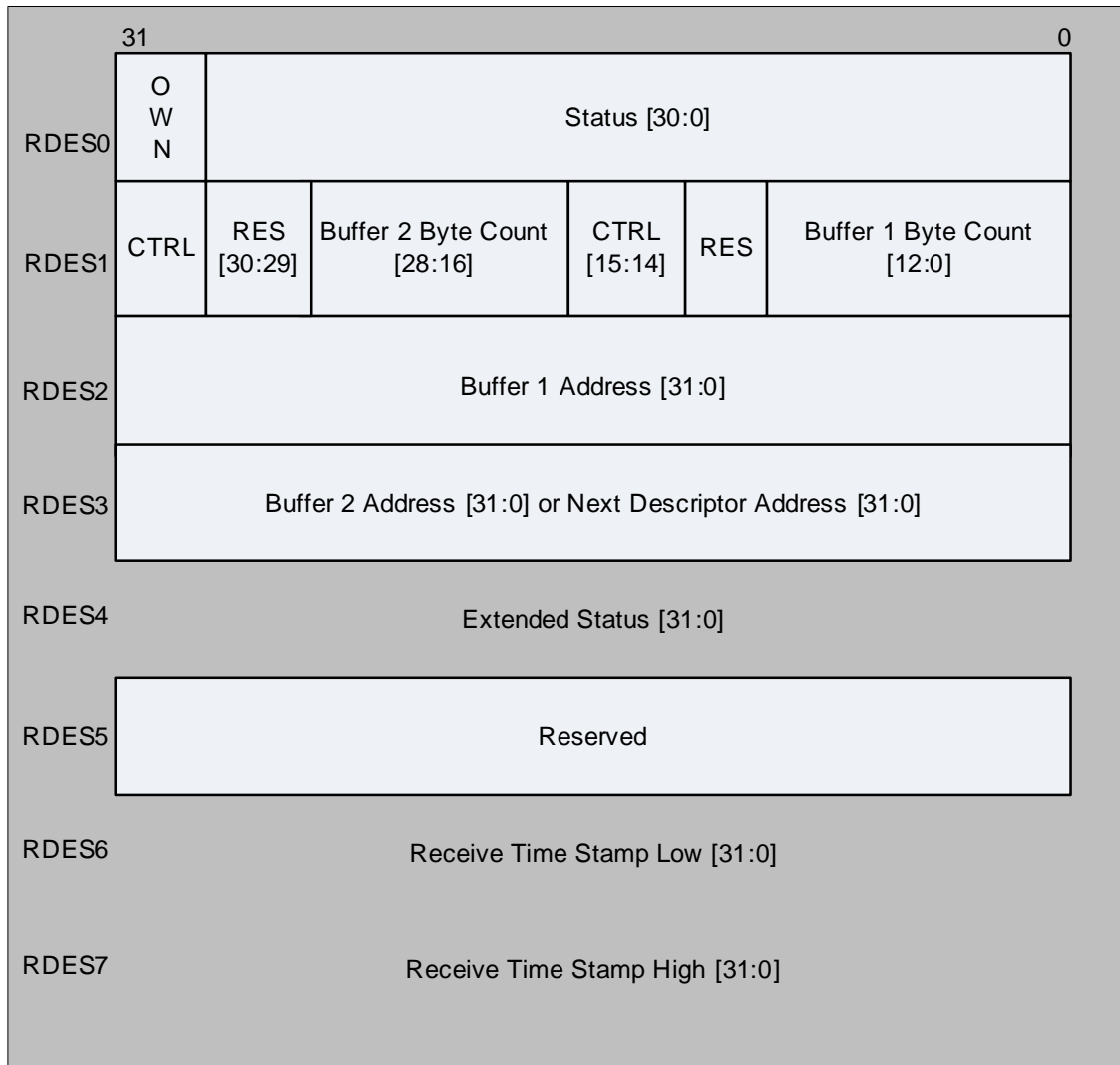

Fig 78. Receive descriptor fields (alternate configuration)

The contents of RDES0 are identified in [Table 581](#). The contents of RDES1 through RDES3 are identified in [Table 582](#) to [Table 584](#).

Table 581. Receive descriptor fields 0 (RDES0)

Bit	Symbol	Description
0	ESA	Extended Status Available/Rx MAC Address When Advanced Timestamp is present, this bit, when set, indicates that the extended status is available in descriptor word 4 (RDES4). This is valid only when the Last Descriptor bit (RDES0[8]) is set. When Advance Timestamp Feature is not selected, this bit indicates Rx MAC Address status. When set, this bit indicates that the Rx MAC Address registers value (1 to 31) matched the frame's DA field. When reset, this bit indicates that the Rx MAC Address Register 0 value matched the DA field.
1	CE	CRC Error When set, this bit indicates that a Cyclic Redundancy Check (CRC) Error occurred on the received frame. This field is valid only when the Last Descriptor (RDES0[8]) is set.
2	DE	Dribble Bit Error When set, this bit indicates that the received frame has a non-integer multiple of bytes (odd nibbles). This bit is valid only in MII Mode.
3	RE	Receive Error When set, this bit indicates that the receive error signal is asserted while receive data valid signal is asserted during frame reception. This error also includes carrier extension error in MII and Half-duplex mode. Error can be of less/no extension, or error (rxd \neq 0f) during extension.
4	RWT	Receive Watchdog Timeout When set, this bit indicates that the Receive Watchdog Timer has expired while receiving the current frame and the current frame is truncated after the Watchdog Timeout.
5	FT	Frame Type When set, this bit indicates that the Receive Frame is an Ethernet-type frame (the LT field is greater than or equal to 0x0600). When this bit is reset, it indicates that the received frame is an IEEE802.3 frame. This bit is not valid for Runt frames less than 14 bytes.
6	LC	Late Collision When set, this bit indicates that a late collision has occurred while receiving the frame in Half-Duplex mode.
7	TSA	Timestamp Available when Advanced Timestamp feature is present. When set, this bit indicates that a snapshot of the Timestamp is written in descriptor words 6 (RDES6) and 7 (RDES7). This is valid only when the Last Descriptor bit (RDES0[8]) is set.
8	LS	Last Descriptor When set, this bit indicates that the buffers pointed to by this descriptor are the last buffers of the frame
9	FS	First Descriptor When set, this bit indicates that this descriptor contains the first buffer of the frame. If the size of the first buffer is 0, the second buffer contains the beginning of the frame. If the size of the second buffer is also 0, the next Descriptor contains the beginning of the frame.
10	VLAN	VLAN Tag When set, this bit indicates that the frame pointed to by this descriptor is a VLAN frame tagged by the MAC Core.
11	OE	Overflow Error When set, this bit indicates that the received frame was damaged due to buffer overflow in MTL.

Table 581. Receive descriptor fields 0 (RDES0)

Bit	Symbol	Description
12	LE	Length Error When set, this bit indicates that the actual length of the frame received and that the Length/ Type field does not match. This bit is valid only when the Frame Type (RDES0[5]) bit is reset.
13	SAF	Source Address Filter Fail When set, this bit indicates that the SA field of frame failed the SA Filter in the MAC Core.
14	DE	Descriptor Error When set, this bit indicates a frame truncation caused by a frame that does not fit within the current descriptor buffers, and that the DMA does not own the Next Descriptor. The frame is truncated. This field is valid only when the Last Descriptor (RDES0[8]) is set.
15	ES	ES: Error Summary Indicates the logical OR of the following bits: <ul style="list-style-type: none"> • RDES0[1]: CRC Error • RDES0[3]: Receive Error • RDES0[4]: Watchdog Timeout • RDES0[6]: Late Collision • RDES0[7]: Giant Frame • RDES4[4:3]: IP Header/Payload Error • RDES0[11]: Overflow Error • RDES0[14]: Descriptor Error This field is valid only when the Last Descriptor (RDES0[8]) is set.
29:16	FL	Frame Length These bits indicate the byte length of the received frame that was transferred to host memory (including CRC). This field is valid when Last Descriptor (RDES0[8]) is set and either the Descriptor Error (RDES0[14]) or Overflow Error bits are reset. This field is valid when Last Descriptor (RDES0[8]) is set. When the Last Descriptor and Error Summary bits are not set, this field indicates the accumulated number of bytes that have been transferred for the current frame.
30	AFM	Destination Address Filter Fail When set, this bit indicates a frame that failed in the DA Filter in the MAC Core.
31	OWN	Own Bit When set, this bit indicates that the descriptor is owned by the DMA of the MAC Subsystem. When this bit is reset, this bit indicates that the descriptor is owned by the Host. The DMA clears this bit either when it completes the frame reception or when the buffers that are associated with this descriptor are full.

Table 582. Receive descriptor fields 1 (RDES1)

Bit	Symbol	Description
12:0	RBS1	Receive Buffer 1 Size Indicates the first data buffer size in bytes. The buffer size must be a multiple of 4, 8, or 16, depending upon the bus widths (32, 64, or 128), even if the value of RDES2 (buffer1 address pointer) is not aligned. When the buffer size is not a multiple of 4, 8, or 16, the resulting behavior is undefined. If this field is 0, the DMA ignores this buffer and uses Buffer 2 or next descriptor depending on the value of RCH (Bit 14). See Section 26.7.6.1.3 for further details on calculating buffer sizes.
13	-	Reserved
14	RCH	Second Address Chained When set, this bit indicates that the second address in the descriptor is the Next Descriptor address rather than the second buffer address. When this bit is set, RBS2 (RDES1[28:16]) is a “don’t care” value. RDES1[15] takes precedence over RDES1[14].
15	RER	Receive End of Ring When set, this bit indicates that the descriptor list reached its final descriptor. The DMA returns to the base address of the list, creating a descriptor ring.
28:16	RBS2	Receive Buffer 2 Size These bits indicate the second data buffer size, in bytes. The buffer size must be a multiple of 4, even if the value of RDES3 (buffer2 address pointer) is not aligned to bus width. If the buffer size is not an appropriate multiple of 4, the resulting behavior is undefined. This field is not valid if RDES1[14] is set. See Section 26.7.6.1.3 for further details on calculating buffer sizes.

Table 583. Receive descriptor fields 2 (RDES2)

Bit	Symbol	Description
31:0	B1ADD	Address Pointer These bits indicate the physical address of Buffer 1. There are no limitations on the buffer address alignment except for the following condition: The DMA uses the configured value for its address generation when the RDES2 value is used to store the start of frame. Note that the DMA performs a write operation with the RDES20 bits as 0 during the transfer of the start of frame but the frame data is shifted as per the actual Buffer address pointer. The DMA ignores RDES20 if the address pointer is to a buffer where the middle or last part of the frame is stored. See Section 26.7.6.1.2 for further details on buffer address alignment.

Table 584. Receive descriptor fields 3 (RDES3)

Bit	Symbol	Description
31:0	B2ADD	Buffer 2 Address Pointer (Next Descriptor Address) These bits indicate the physical address of Buffer 2 when a descriptor ring structure is used. If the Second Address Chained (RDES1[24]) bit is set, this address contains the pointer to the physical memory where the Next Descriptor is present. If RDES1[24] is set, the buffer (Next Descriptor) address pointer must be bus width-aligned (RDES3[1:0] = 0. LSBs are ignored internally.) However, when RDES1[24] is reset, there are no limitations on the RDES3 value, except for the following condition: The DMA uses the configured value for its buffer address generation when the RDES3 value is used to store the start of frame. The DMA ignores RDES3 [1:0] if the address pointer is to a buffer where the middle or last part of the frame is stored.

The extended status written is as shown in [Table 585](#). The extended status is written only when there is status related to IPC or timestamp available. The availability of extended status is indicated by bit-0 of RDES0. This status is available only when Advance Timestamp or IPC Full Offload feature is selected.

Table 585. Receive descriptor fields 4 (RDES4)

Bit	Symbol	Description
2:0	-	Reserved
3	-	Reserved
4	-	Reserved
5	-	-
6	IPV4	IPv4 Packet Received When set, this bit indicates that the received packet is an IPv4 packet.
7	IPV6	IPv6 Packet Received When set, this bit indicates that the received packet is an IPv6 packet.
11:8	MT	Message Type These bits are encoded to give the type of the message received. <ul style="list-style-type: none"> • 0000: No PTP message received • 0001: SYNC (all clock types) • 0010: Follow_Up (all clock types) • 0011: Delay_Req (all clock types) • 0100: Delay_Resp (all clock types) • 0101: Pdelay_Req (in peer-to-peer transparent clock) • 0110: Pdelay_Resp (in peer-to-peer transparent clock) • 0111: Pdelay_Resp_Follow_Up (in peer-to-peer transparent clock) • 1000: Announce • 1001: Management • 1010: Signaling • 1011-1110: Reserved • 1111: PTP packet with Reserved message type These bits are used for the Advance Timestamp feature.
12	PTPTYPE	PTP Frame Type When set, this bit that the PTP message is sent directly over Ethernet. When this bit is not set and the message type is non-zero, it indicates that the PTP message is sent over UDP-IPv4 or UDP-IPv6. The information on IPv4 or IPv6 can be obtained from bits 6 and 7.
13	PTPVERSION	PTP Version When set, indicates that the received PTP message is having the IEEE 1588 version 2 format. When reset, it has the version 1 format. This is valid only if the message type is non-zero.
31:14	-	Reserved.

RDES6 and RDES7 contain the snapshot of the time-stamp. The availability of the snapshot of the time-stamp in RDES6 and RDES7 is indicated by bit-7 in the RDES0 descriptor. The contents of RDES6 and RDES7 are identified in [Table 586](#) and [Table 587](#).

Table 586. Receive descriptor fields 6 (RDES6)

Bit	Symbol	Description
31:0	RTSL	Receive Frame Timestamp Low This field is updated by DMA with the least significant 32 bits of the timestamp captured for the corresponding receive frame. This field is updated by DMA only for the last descriptor of the receive frame which is indicated by Last Descriptor status bit (RDES0[8]).

Table 587. Receive descriptor fields 7 (RDES7)

Bit	Symbol	Description
31:0	RTSH	Receive Frame Timestamp High This field is updated by DMA with the most significant 32 bits of the timestamp captured for the corresponding receive frame. This field is updated by DMA only for the last descriptor of the receive frame which is indicated by Last Descriptor status bit (RDES0[8]).

27.1 How to read this chapter

The LCD controller is available on parts LPC185x only.

27.2 Basic configuration

The LCD controller is configured as follows:

- See [Table 588](#) for clocking and power control.
- The LCD is reset by the LCD_RST (reset # 16).
- The LCD interrupt is connected to interrupt slot # 7 in the NVIC.

Table 588. LCD clocking and power control

	Base clock	Branch clock	Operating frequency
LCD register interface clock	BASE_M3_CLK	CLK_M3_LCD	up to 180 MHz

27.3 Features

- AHB bus master interface to access frame buffer.
- Setup and control via a separate AHB slave interface.
- Dual 16-deep programmable 64-bit wide FIFOs for buffering incoming display data.
- Supports single and dual-panel monochrome Super Twisted Nematic (STN) displays with 4 or 8-bit interfaces.
- Supports single and dual-panel color STN displays.
- Supports Thin Film Transistor (TFT) color displays.
- Programmable display resolution including, but not limited to: 320x200, 320x240, 640x200, 640x240, 640x480, 800x600, and 1024x768.
- Hardware cursor support for single-panel displays.
- 15 gray-level monochrome, 3375 color STN, and 32K color palettized TFT support.
- 1, 2, or 4 bits-per-pixel (bpp) palettized displays for monochrome STN.
- 1, 2, 4, or 8 bpp palettized color displays for color STN and TFT.
- 16 bpp true-color non-palettized, for color STN and TFT.
- 24 bpp true-color non-palettized, for color TFT.
- Programmable timing for different display panels.
- 256 entry, 16-bit palette RAM, arranged as a 128x32-bit RAM.
- Frame, line, and pixel clock signals.
- AC bias signal for STN, data enable signal for TFT panels.
- Supports little and big-endian, and Windows CE data formats.

- LCD panel clock may be generated from the peripheral clock, or from a clock input pin.

27.4 General description

The LCD controller performs translation of pixel-coded data into the required formats and timings to drive a variety of single or dual panel monochrome and color LCDs.

Packets of pixel coded data are fed using the AHB interface, to two independent, programmable, 32-bit wide, DMA FIFOs that act as input data flow buffers.

The buffered pixel coded data is then unpacked using a pixel serializer.

Depending on the LCD type and mode, the unpacked data can represent:

- An actual true display gray or color value.
- An address to a 256x16 bit wide palette RAM gray or color value.

In the case of STN displays, either a value obtained from the addressed palette location, or the true value is passed to the gray scaling generators. The hardware-coded gray scale algorithm logic sequences the activity of the addressed pixels over a programmed number of frames to provide the effective display appearance.

For TFT displays, either an addressed palette value or true color value is passed directly to the output display drivers, bypassing the gray scaling algorithmic logic.

In addition to data formatting, the LCD controller provides a set of programmable display control signals, including:

- LCD panel power enable
- Pixel clock
- Horizontal and vertical synchronization pulses
- Display bias

The LCD controller generates individual interrupts for:

- Upper or lower panel DMA FIFO underflow
- Base address update signification
- Vertical compare
- Bus error

There is also a single combined interrupt that is asserted when any of the individual interrupts become active.

[Figure 79](#) shows a simplified block diagram of the LCD controller.

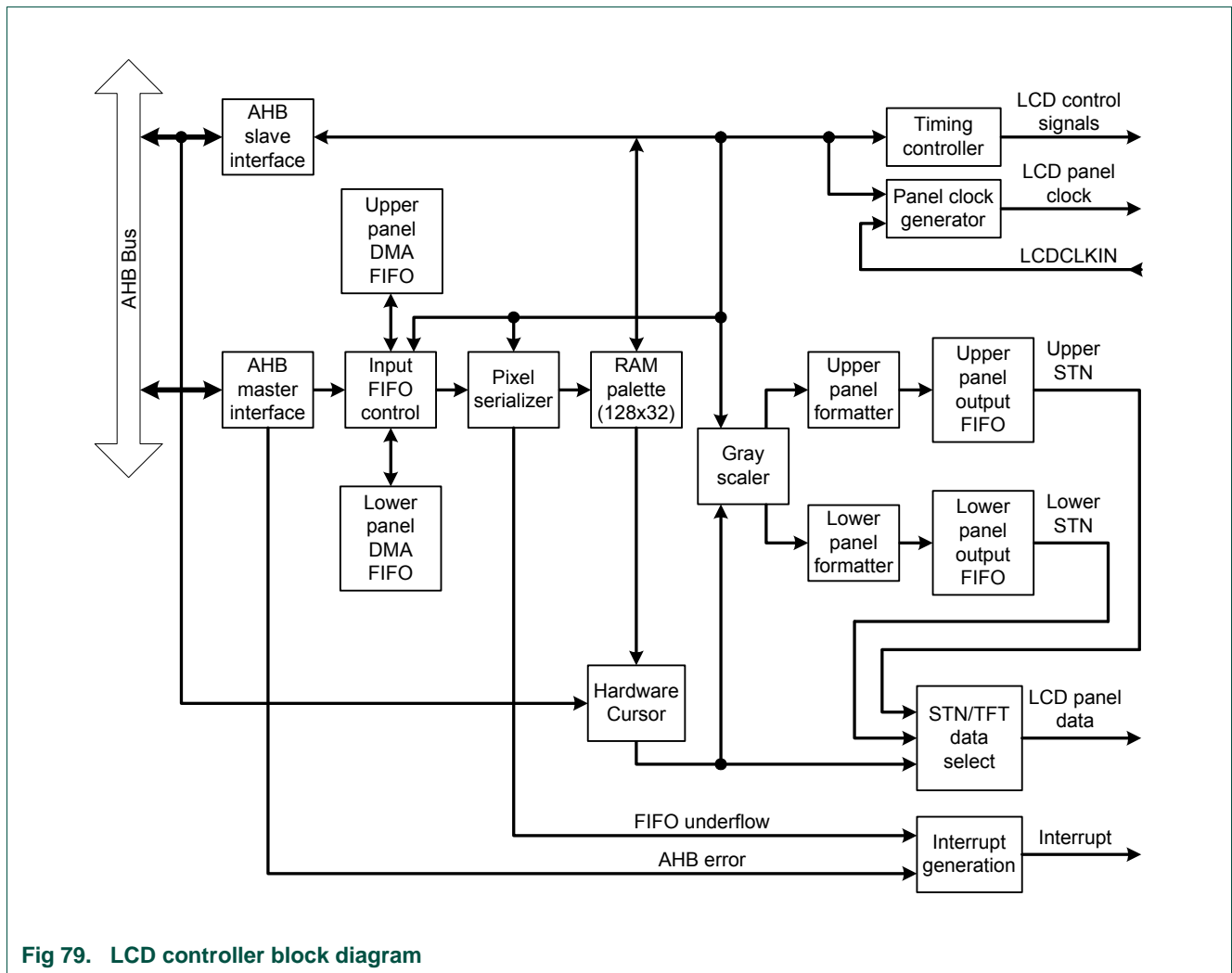

Fig 79. LCD controller block diagram

27.4.1 Programmable parameters

The following key display and controller parameters can be programmed:

- Horizontal front and back porch
- Horizontal synchronization pulse width
- Number of pixels per line
- Vertical front and back porch
- Vertical synchronization pulse width
- Number of lines per panel
- Number of pixel clocks per line
- Hardware cursor control.
- Signal polarity, active HIGH or LOW
- AC panel bias
- Panel clock frequency
- Bits-per-pixel

- Display type: STN monochrome, STN color, or TFT
- STN 4 or 8-bit interface mode
- STN dual or single panel mode
- Little-endian, big-endian, or Windows CE mode
- Interrupt generation event

27.4.2 Hardware cursor support

The hardware cursor feature reduces software overhead associated with maintaining a cursor image in the LCD frame buffer.

Without this feature, software needed to:

- Save an image of the area under the next cursor position.
- Update the area with the cursor image.
- Repair the last cursor position with a previously saved image.

In addition, the LCD driver had to check whether the graphics operation had overwritten the cursor, and correct it. With a cursor size of 64x64 and 24-bit color, each cursor move involved reading and writing approximately 75 kB of data.

The hardware cursor removes the requirement for this management by providing a completely separate image buffer for the cursor, and superimposing the cursor image on the LCD output stream at the current cursor (X,Y) coordinate.

To move the hardware cursor, the software driver supplies a new cursor coordinate. The frame buffer requires no modification. This significantly reduces software overhead.

The cursor image is held in the LCD controller in an internal 256x32-bit buffer memory.

27.4.3 Types of LCD panels supported

The LCD controller supports the following types of LCD panel:

- Active matrix TFT panels with up to 24-bit bus interface.
- Single-panel monochrome STN panels (4-bit and 8-bit bus interface).
- Dual-panel monochrome STN panels (4-bit and 8-bit bus interface per panel).
- Single-panel color STN panels, 8-bit bus interface.
- Dual-panel color STN panels, 8-bit bus interface per panel.

27.4.3.1 TFT panels

TFT panels support one or more of the following color modes:

- 1 bpp, palettized, 2 colors selected from available colors.
- 2 bpp, palettized, 4 colors selected from available colors.
- 4 bpp, palettized, 16 colors selected from available colors.
- 8 bpp, palettized, 256 colors selected from available colors.
- 12 bpp, direct 4:4:4 RGB.

- 16 bpp, direct 5:5:5 RGB, with 1 bpp not normally used. This pixel is still output, and can be used as a brightness bit to connect to the Least Significant Bit (LSB) of RGB components of a 6:6:6 TFT panel.
- 16 bpp, direct 5:6:5 RGB.
- 24 bpp, direct 8:8:8 RGB, providing over 16 million colors.

Each 16-bit palette entry is composed of 5 bpp (RGB), plus a common intensity bit. This provides better memory utilization and performance compared with a full 6 bpp structure. The total number of colors supported can be doubled from 32K to 64K if the intensity bit is used and applied to all three color components simultaneously.

Alternatively, the 16 signals can be used to drive a 5:6:5 panel with the extra bit only applied to the green channel.

27.4.3.2 Color STN panels

Color STN panels support one or more of the following color modes:

- 1 bpp, palettized, 2 colors selected from 3375.
- 2 bpp, palettized, 4 colors selected from 3375.
- 4 bpp, palettized, 16 colors selected from 3375.
- 8 bpp, palettized, 256 colors selected from 3375.
- 16 bpp, direct 4:4:4 RGB, with 4 bpp not being used.

27.4.3.3 Monochrome STN panels

Monochrome STN panels support one or more of the following modes:

- 1 bpp, palettized, 2 gray scales selected from 15.
- 2 bpp, palettized, 4 gray scales selected from 15.
- 4 bpp, palettized, 16 gray scales selected from 15.

More than 4 bpp for monochrome panels can be programmed, but using these modes has no benefit because the maximum number of gray scales supported on the display is 15.

27.5 Pin description

The largest configuration for the LCD controller uses 31 pins. There are many variants using as few as 10 pins for a monochrome STN panel. Pins are allocated in groups based on the selected configuration. All LCD functions are shared with other chip functions. In [Table 589](#), only the LCD related portion of the pin name is shown.

Table 589. LCD controller pins

Pin function	Type	Function
LCDPWR	Output	LCD panel power enable.
LCDCLK	Output	LCD panel clock.
LCDENAB/LCDM (LCDAC)	Output	STN AC bias drive or TFT data enable output.
LCDFP	Output	Frame pulse (STN). Vertical synchronization pulse (TFT)
LCDLE	Output	Line end signal

Table 589. LCD controller pins

Pin function	Type	Function
LCDLP	Output	Line synchronization pulse (STN). Horizontal synchronization pulse (TFT)
LCDVD[23:0]	Output	LCD panel data. Bits used depend on the panel configuration.
GP_CLKIN	Input	General purpose CGU input clock. Can be used as the LCD external clock LCDCLKIN.

27.5.1 Signal usage

The signals that are used for various display types are identified in the following sections.

27.5.1.1 Signals used for single panel STN displays

The signals used for single panel STN displays are shown in [Table 590](#). UD refers to upper panel data.

Table 590. Pins used for single panel STN displays

Pin name	4-bit Monochrome (10 pins)	8-bit Monochrome (14 pins)	Color (14 pins)
LCDPWR	Y	Y	Y
LCDDCLK	Y	Y	Y
LCDENAB/ LCDM	Y	Y	Y
LCDFP	Y	Y	Y
LCDLE	Y	Y	Y
LCDLP	Y	Y	Y
LCDVD[3:0]	UD[3:0]	UD[3:0]	UD[3:0]
LCDVD[7:4]	-	UD[7:4]	UD[7:4]
LCDVD[23:8]	-	-	-

27.5.1.2 Signals used for dual panel STN displays

The signals used for dual panel STN displays are shown in [Table 591](#). UD refers to upper panel data, and LD refers to lower panel data.

Table 591. Pins used for dual panel STN displays

Pin name	4-bit Monochrome (14 pins)	8-bit Monochrome (22 pins)	Color (22 pins)
LCDPWR	Y	Y	Y
LCDDCLK	Y	Y	Y
LCDENAB/ LCDM	Y	Y	Y
LCDFP	Y	Y	Y
LCDLE	Y	Y	Y
LCDLP	Y	Y	Y
LCDVD[3:0]	UD[3:0]	UD[3:0]	UD[3:0]
LCDVD[7:4]	-	UD[7:4]	UD[7:4]

Table 591. Pins used for dual panel STN displays

Pin name	4-bit Monochrome (14 pins)	8-bit Monochrome (22 pins)	Color (22 pins)
LCDVD[11:8]	LD[3:0]	LD[3:0]	LD[3:0]
LCDVD[15:12]	-	LD[7:4]	LD[7:4]
LCDVD[23:16]	-	-	-

27.5.1.3 Signals used for TFT displays

The signals used for TFT displays are shown in [Table 592](#).

Table 592. Pins used for TFT displays

Pin name	12-bit, 4:4:4 mode (18 pins)	16-bit, 5:6:5 mode (22 pins)	16-bit, 1:5:5:5 mode (24 pins)	24-bit (30 pins)
LCDPWR	Y	Y	Y	Y
LCDDCLK	Y	Y	Y	Y
LCDENAB/ LCDM	Y	Y	Y	Y
LCDFP	Y	Y	Y	Y
LCDLE	Y	Y	Y	Y
LCDLP	Y	Y	Y	Y
LCDVD[1:0]	-	-	-	RED[1:0]
LCDVD[2]	-	-	Intensity	RED[2]
LCDVD[3]	-	RED[0]	RED[0]	RED[3]
LCDVD[7:4]	RED[3:0]	RED[4:1]	RED[4:1]	RED[7:4]
LCDVD[9:8]	-	-	-	GREEN[1:0]
LCDVD[10]	-	GREEN[0]	Intensity	GREEN[2]
LCDVD[11]	-	GREEN[1]	GREEN[0]	GREEN[3]
LCDVD[15:12]	GREEN[3:0]	GREEN[5:2]	GREEN[4:1]	GREEN[7:4]
LCDVD[17:16]	-	-	-	BLUE[1:0]
LCDVD[18]	-	-	Intensity	BLUE[2]
LCDVD[19]	-	BLUE[0]	BLUE[0]	BLUE[3]
LCDVD[23:20]	BLUE[3:0]	BLUE[4:1]	BLUE[4:1]	BLUE[7:4]

27.6 Register description

[Table 593](#) shows the registers associated with the LCD controller and a summary of their functions. Following the table are details for each register.

Table 593. Register overview: LCD controller (base address: 0x4000 8000)

Name	Access	Address offset	Description	Reset value [1]	Reference [1]
TIMH	R/W	0x000	Horizontal Timing Control register	0x0	Table 594
TIMV	R/W	0x004	Vertical Timing Control register	0x0	Table 595
POL	R/W	0x008	Clock and Signal Polarity Control register	0x0	Table 596

Table 593. Register overview: LCD controller (base address: 0x4000 8000) ...continued

Name	Access	Address offset	Description	Reset value [1]	Reference
LE	R/W	0x00C	Line End Control register	0x0	Table 597
UPBASE	R/W	0x010	Upper Panel Frame Base Address register	0x0	Table 598
LPBASE	R/W	0x014	Lower Panel Frame Base Address register	0x0	Table 599
CTRL	R/W	0x018	LCD Control register	0x0	Table 600
INTMSK	R/W	0x01C	Interrupt Mask register	0x0	Table 601
INTRAW	RO	0x020	Raw Interrupt Status register	0x0	Table 602
INTSTAT	RO	0x024	Masked Interrupt Status register	0x0	Table 603
INTCLR	WO	0x028	Interrupt Clear register	0x0	Table 604
UPCURR	RO	0x02C	Upper Panel Current Address Value register	0x0	Table 605
LPCURR	RO	0x030	Lower Panel Current Address Value register	0x0	Table 606
-	-	0x034 to 0x1FC	Reserved	-	-
PAL	R/W	0x200 to 0x3FC	256x16-bit Color Palette registers	0x0	Table 607
-	-	0x400 to 0x7FC	Reserved	-	-
CRSR_IMG	R/W	0x800 to 0xBFC	Cursor Image registers	0x0	Table 608
CRSR_CTRL	R/W	0xC00	Cursor Control register	0x0	Table 609
CRSR_CFG	R/W	0xC04	Cursor Configuration register	0x0	Table 610
CRSR_PAL0	R/W	0xC08	Cursor Palette register 0	0x0	Table 611
CRSR_PAL1	R/W	0xC0C	Cursor Palette register 1	0x0	Table 612
CRSR_XY	R/W	0xC10	Cursor XY Position register	0x0	Table 613
CRSR_CLIP	R/W	0xC14	Cursor Clip Position register	0x0	Table 614
CRSR_INTMSK	R/W	0xC20	Cursor Interrupt Mask register	0x0	Table 615
CRSR_INTCLR	WO	0xC24	Cursor Interrupt Clear register	0x0	Table 616
CRSR_INTRAW	RO	0xC28	Cursor Raw Interrupt Status register	0x0	Table 617
CRSR_INTSTAT	RO	0xC2C	Cursor Masked Interrupt Status register	0x0	Table 618

[1] Reset Value reflects the data stored in used bits only. It does not include reserved bits content.

27.6.1 Horizontal Timing register

The TIMH register controls the Horizontal Synchronization pulse Width (HSW), the Horizontal Front Porch (HFP) period, the Horizontal Back Porch (HBP) period, and the Pixels-Per-Line (PPL).

Table 594. Horizontal Timing register (TIMH, address 0x4000 8000) bit description

Bit	Symbol	Description	Reset value
1:0	-	Reserved, user software should not write ones to reserved bits. The value read from a reserved bit is not defined.	-
7:2	PPL	<p>Pixels-per-line.</p> <p>The PPL bit field specifies the number of pixels in each line or row of the screen. PPL is a 6-bit value that represents between 16 and 1024 pixels per line. PPL counts the number of pixel clocks that occur before the HFP is applied.</p> <p>Program the value required divided by 16, minus 1. Actual pixels-per-line = 16 * (PPL + 1). For example, to obtain 320 pixels per line, program PPL as (320/16) - 1 = 19.</p>	0x0
15:8	HSW	<p>Horizontal synchronization pulse width.</p> <p>The 8-bit HSW field specifies the pulse width of the line clock in passive mode, or the horizontal synchronization pulse in active mode. Program with desired value minus 1.</p>	0x0
23:16	HFP	<p>Horizontal front porch.</p> <p>The 8-bit HFP field sets the number of pixel clock intervals at the end of each line or row of pixels, before the LCD line clock is pulsed. When a complete line of pixels is transmitted to the LCD driver, the value in HFP counts the number of pixel clocks to wait before asserting the line clock. HFP can generate a period of 1-256 pixel clock cycles. Program with desired value minus 1.</p>	0x0
31:24	HBP	<p>Horizontal back porch.</p> <p>The 8-bit HBP field is used to specify the number of pixel clock periods inserted at the beginning of each line or row of pixels. After the line clock for the previous line has been deasserted, the value in HBP counts the number of pixel clocks to wait before starting the next display line. HBP can generate a delay of 1-256 pixel clock cycles. Program with desired value minus 1.</p>	0x0

27.6.1.1 Horizontal timing restrictions

DMA requests new data at the start of a horizontal display line. Some time must be allowed for the DMA transfer and for data to propagate down the FIFO path in the LCD interface. The data path latency forces some restrictions on the usable minimum values for horizontal porch width in STN mode. The minimum values are HSW = 2 and HBP = 2.

Single panel mode:

- HSW = 3 pixel clock cycles
- HBP = 5 pixel clock cycles
- HFP = 5 pixel clock cycles
- Panel Clock Divisor (PCD) = 1 (LCDCLK / 3)

Dual panel mode:

- HSW = 3 pixel clock cycles
- HBP = 5 pixel clock cycles
- HFP = 5 pixel clock cycles

- $PCD = 5 (LCDCLK / 7)$

If enough time is given at the start of the line, for example, setting HSW = 6, HBP = 10, data does not corrupt for PCD = 4, the minimum value.

27.6.2 Vertical Timing register

The TIMV register controls the Vertical Synchronization pulse Width (VSW), the Vertical Front Porch (VFP) period, the Vertical Back Porch (VBP) period, and the Lines-Per-Panel (LPP).

Table 595. Vertical Timing register (TIMV, address 0x4000 8004) bit description

Bit	Symbol	Description	Reset value
9:0	LPP	Lines per panel. This is the number of active lines per screen. The LPP field specifies the total number of lines or rows on the LCD panel being controlled. LPP is a 10-bit value allowing between 1 and 1024 lines. Program the register with the number of lines per LCD panel, minus 1. For dual panel displays, program the register with the number of lines on each of the upper and lower panels.	0x0
15:10	VSW	Vertical synchronization pulse width. This is the number of horizontal synchronization lines. The 6-bit VSW field specifies the pulse width of the vertical synchronization pulse. Program the register with the number of lines required, minus one. The number of horizontal synchronization lines must be small (for example, program to zero) for passive STN LCDs. The higher the value the worse the contrast on STN LCDs.	0x0
23:16	VFP	Vertical front porch. This is the number of inactive lines at the end of a frame, before the vertical synchronization period. The 8-bit VFP field specifies the number of line clocks to insert at the end of each frame. When a complete frame of pixels is transmitted to the LCD display, the value in VFP is used to count the number of line clock periods to wait. After the count has elapsed, the vertical synchronization signal, LCDFP, is asserted in active mode, or extra line clocks are inserted as specified by the VSW bit-field in passive mode. VFP generates 0–255 line clock cycles. Program to zero on passive displays for improved contrast.	0x0
31:24	VBP	Vertical back porch. This is the number of inactive lines at the start of a frame, after the vertical synchronization period. The 8-bit VBP field specifies the number of line clocks inserted at the beginning of each frame. The VBP count starts immediately after the vertical synchronization signal for the previous frame has been negated for active mode, or the extra line clocks have been inserted as specified by the VSW bit field in passive mode. After this has occurred, the count value in VBP sets the number of line clock periods inserted before the next frame. VBP generates 0–255 extra line clock cycles. Program to zero on passive displays for improved contrast.	0x0

27.6.3 Clock and Signal Polarity register

The POL register controls various details of clock timing and signal polarity.

Table 596. Clock and Signal Polarity register (POL, address 0x4000 8008) bit description

Bit	Symbol	Description	Reset value
4:0	PCD_LO	<p>Lower five bits of panel clock divisor.</p> <p>The ten-bit PCD field, comprising PCD_HI (bits 31:27 of this register) and PCD_LO, is used to derive the LCD panel clock frequency LCDDCLK from the input clock, $LCDDCLK = LCDCLK/(PCD+2)$.</p> <p>For monochrome STN displays with a 4 or 8-bit interface, the panel clock is a factor of four and eight down from the actual individual pixel clock rate. For color STN displays, 22/3 pixels are output per LCDDCLK cycle, so the panel clock is 0.375 times the pixel rate.</p> <p>For TFT displays, the pixel clock divider can be bypassed by setting the BCD bit in this register.</p> <p>Note: data path latency forces some restrictions on the usable minimum values for the panel clock divider in STN modes: Single panel color mode, $PCD = 1$ ($LCDDCLK = LCDCLK/3$). Dual panel color mode, $PCD = 4$ ($LCDDCLK = LCDCLK/6$). Single panel monochrome 4-bit interface mode, $PCD = 2$ ($LCDDCLK = LCDCLK/4$). Dual panel monochrome 4-bit interface mode and single panel monochrome 8-bit interface mode, $PCD = 6$ ($LCDDCLK = LCDCLK/8$). Dual panel monochrome 8-bit interface mode, $PCD = 14$ ($LCDDCLK = LCDCLK/16$).</p>	0x0
5	CLKSEL	<p>Clock Select.</p> <p>This bit controls the selection of the source for LCDCLK.</p> <p>0 = the clock source for the LCD block is CCLK. 1 = the clock source for the LCD block is LCDCLKIN (external clock input for the LVD).</p>	0x0
10:6	ACB	<p>AC bias pin frequency.</p> <p>The AC bias pin frequency is only applicable to STN displays. These require the pixel voltage polarity to periodically reverse to prevent damage caused by DC charge accumulation. Program this field with the required value minus one to apply the number of line clocks between each toggle of the AC bias pin, LCDENAB. This field has no effect if the LCD is operating in TFT mode, when the LCDENAB pin is used as a data enable signal.</p>	0x0
11	IVS	<p>Invert vertical synchronization.</p> <p>The IVS bit inverts the polarity of the LCDFP signal.</p> <p>0 = LCDFP pin is active HIGH and inactive LOW. 1 = LCDFP pin is active LOW and inactive HIGH.</p>	0x0
12	IHS	<p>Invert horizontal synchronization.</p> <p>The IHS bit inverts the polarity of the LCDLP signal.</p> <p>0 = LCDLP pin is active HIGH and inactive LOW. 1 = LCDLP pin is active LOW and inactive HIGH.</p>	0x0

Table 596. Clock and Signal Polarity register (POL, address 0x4000 8008) bit description

Bit	Symbol	Description	Reset value
13	IPC	Invert panel clock. The IPC bit selects the edge of the panel clock on which pixel data is driven out onto the LCD data lines. 0 = Data is driven on the LCD data lines on the rising edge of LCDDCLK. 1 = Data is driven on the LCD data lines on the falling edge of LCDDCLK.	0x0
14	IOE	Invert output enable. This bit selects the active polarity of the output enable signal in TFT mode. In this mode, the LCDENAB pin is used as an enable that indicates to the LCD panel when valid display data is available. In active display mode, data is driven onto the LCD data lines at the programmed edge of LCDDCLK when LCDENAB is in its active state. 0 = LCDENAB output pin is active HIGH in TFT mode. 1 = LCDENAB output pin is active LOW in TFT mode.	0x0
15	-	Reserved, user software should not write ones to reserved bits. The value read from a reserved bit is not defined.	-
25:16	CPL	Clocks per line. This field specifies the number of actual LCDDCLK clocks to the LCD panel on each line. This is the number of PPL divided by either 1 (for TFT), 4 or 8 (for monochrome passive), 2 2/3 (for color passive), minus one. This must be correctly programmed in addition to the PPL bit in the TIMH register for the LCD display to work correctly.	0x0
26	BCD	Bypass pixel clock divider. Setting this to 1 bypasses the pixel clock divider logic. This is mainly used for TFT displays.	0x0
31:27	PCD_HI	Upper five bits of panel clock divisor. See description for PCD_LO, in bits [4:0] of this register.	0x0

27.6.4 Line End Control register

The LE register controls the enabling of line-end signal LCDLE. When enabled, a positive pulse, four LCDCLK periods wide, is output on LCDLE after a programmable delay, LED, from the last pixel of each display line. If the line-end signal is disabled it is held permanently LOW.

Table 597. Line End Control register (LE, address 0x4000 800C) bit description

Bit	Symbol	Description	Reset value
6:0	LED	Line-end delay. Controls Line-end signal delay from the rising-edge of the last panel clock, LCDDCLK. Program with number of LCDCLK clock periods minus 1.	0x0
15:7	-	Reserved, user software should not write ones to reserved bits. The value read from a reserved bit is not defined.	-
16	LEE	LCD Line end enable. 0 = LCDLE disabled (held LOW). 1 = LCDLE signal active.	0x0
31:17	-	Reserved, user software should not write ones to reserved bits. The value read from a reserved bit is not defined.	-

27.6.5 Upper Panel Frame Base Address register

The UPBASE register is the color LCD upper panel DMA base address register, and is used to program the base address of the frame buffer for the upper panel. LCDUPBase (and LCDLPBase for dual panels) must be initialized before enabling the LCD controller. The base address must be doubleword aligned.

Optionally, the value may be changed mid-frame to create double-buffered video displays. These registers are copied to the corresponding current registers at each LCD vertical synchronization. This event causes the LNBU bit and an optional interrupt to be generated. The interrupt can be used to reprogram the base address when generating double-buffered video.

Table 598. Upper Panel Frame Base register (UPBASE, address 0x4000 8010) bit description

Bit	Symbol	Description	Reset value
2:0	-	Reserved, user software should not write ones to reserved bits. The value read from a reserved bit is not defined.	-
31:3	LCDUPBASE	LCD upper panel base address. This is the start address of the upper panel frame data in memory and is doubleword aligned.	0x0

27.6.6 Lower Panel Frame Base Address register

The LPBASE register is the color LCD lower panel DMA base address register, and is used to program the base address of the frame buffer for the lower panel. LCDLPBase must be initialized before enabling the LCD controller. The base address must be doubleword aligned.

Optionally, the value may be changed mid-frame to create double-buffered video displays. These registers are copied to the corresponding current registers at each LCD vertical synchronization. This event causes the LNBU bit and an optional interrupt to be generated. The interrupt can be used to reprogram the base address when generating double-buffered video.

Table 599. Lower Panel Frame Base register (LPBASE, address 0x4000 8014) bit description

Bit	Symbol	Description	Reset value
2:0	-	Reserved, user software should not write ones to reserved bits. The value read from a reserved bit is not defined.	-
31:3	LCDLPBASE	LCD lower panel base address. This is the start address of the lower panel frame data in memory and is doubleword aligned.	0x0

27.6.7 LCD Control register

The CTRL register controls the LCD operating mode and the panel pixel parameters.

Table 600. LCD Control register (CTRL, address 0x4000 8018) bit description

Bit	Symbol	Description	Reset value
0	LCDEN	LCD enable control bit. 0 = LCD disabled. Signals LCDLP, LCDDCLK, LCDFP, LCDENAB, and LCDLE are low. 1 = LCD enabled. Signals LCDLP, LCDDCLK, LCDFP, LCDENAB, and LCDLE are high. See LCD power-up and power-down sequence for details on LCD power sequencing.	0x0
3:1	LCDBPP	LCD bits per pixel: Selects the number of bits per LCD pixel: 000 = 1 bpp. 001 = 2 bpp. 010 = 4 bpp. 011 = 8 bpp. 100 = 16 bpp. 101 = 24 bpp (TFT panel only). 110 = 16 bpp, 5:6:5 mode. 111 = 12 bpp, 4:4:4 mode.	0x0
4	LCDBW	STN LCD monochrome/color selection. 0 = STN LCD is color. 1 = STN LCD is monochrome. This bit has no meaning in TFT mode.	0x0
5	LCDTFT	LCD panel TFT type selection. 0 = LCD is an STN display. Use gray scaler. 1 = LCD is a TFT display. Do not use gray scaler.	0x0
6	LCDMONO8	Monochrome LCD interface width. This bit controls whether a monochrome STN LCD uses a 4 or 8-bit parallel interface. It has no meaning in other modes and must be programmed to zero. 0 = monochrome LCD uses a 4-bit interface. 1 = monochrome LCD uses a 8-bit interface.	0x0

Table 600. LCD Control register (CTRL, address 0x4000 8018) bit description ...continued

Bit	Symbol	Description	Reset value
7	LCDDUAL	Single or Dual LCD panel selection. STN LCD interface is: 0 = single-panel. 1 = dual-panel.	0x0
8	BGR	Color format selection. 0 = RGB: normal output. 1 = BGR: red and blue swapped.	0x0
9	BEBO	Big-endian Byte Order. Controls byte ordering in memory: 0 = little-endian byte order. 1 = big-endian byte order.	0x0
10	BEPO	Big-Endian Pixel Ordering. Controls pixel ordering within a byte: 0 = little-endian ordering within a byte. 1 = big-endian pixel ordering within a byte. The BEPO bit selects between little and big-endian pixel packing for 1, 2, and 4 bpp display modes, it has no effect on 8 or 16 bpp pixel formats. See Pixel serializer for more information on the data format.	0x0
11	LCDPWR	LCD power enable. 0 = power not gated through to LCD panel and LCDV[23:0] signals disabled, (held LOW). 1 = power gated through to LCD panel and LCDV[23:0] signals enabled, (active). See LCD power-up and power-down sequence for details on LCD power sequencing.	0x0
13:12	LCDVCOMP	LCD Vertical Compare Interrupt. Generate VComp interrupt at: 00 = start of vertical synchronization. 01 = start of back porch. 10 = start of active video. 11 = start of front porch.	0x0
15:14	-	Reserved, user software should not write ones to reserved bits. The value read from a reserved bit is not defined.	-
16	WATERMARK	LCD DMA FIFO watermark level. Controls when DMA requests are generated: 0 = An LCD DMA request is generated when either of the DMA FIFOs have four or more empty locations. 1 = An LCD DMA request is generated when either of the DMA FIFOs have eight or more empty locations.	0x0
31:17	-	Reserved, user software should not write ones to reserved bits. The value read from a reserved bit is not defined.	-

27.6.8 Interrupt Mask register

The INTMSK register controls whether various LCD interrupts occur. Setting bits in this register enables the corresponding raw interrupt INTRAW status bit values to be passed to the INTSTAT register for processing as interrupts.

Table 601. Interrupt Mask register (INTMSK, address 0x4000 801C) bit description

Bit	Symbol	Description	Reset value
0	-	Reserved, user software should not write ones to reserved bits. The value read from a reserved bit is not defined.	-
1	FUFIM	FIFO underflow interrupt enable. 0: The FIFO underflow interrupt is disabled. 1: Interrupt will be generated when the FIFO underflows.	0x0
2	LNBUIM	LCD next base address update interrupt enable. 0: The base address update interrupt is disabled. 1: Interrupt will be generated when the LCD base address registers have been updated from the next address registers.	0x0
3	VCOMPIM	Vertical compare interrupt enable. 0: The vertical compare time interrupt is disabled. 1: Interrupt will be generated when the vertical compare time (as defined by LcdVComp field in the CTRL register) is reached.	0x0
4	BERIM	AHB master error interrupt enable. 0: The AHB Master error interrupt is disabled. 1: Interrupt will be generated when an AHB Master error occurs.	0x0
31:5	-	Reserved, user software should not write ones to reserved bits. The value read from a reserved bit is not defined.	-

27.6.9 Raw Interrupt Status register

The INTRAW register contains status flags for various LCD controller events. These flags can generate an interrupts if enabled by mask bits in the INTMSK register.

Table 602. Raw Interrupt Status register (INTRAW, address 0x4000 8020) bit description

Bit	Symbol	Description	Reset value
0	-	Reserved, user software should not write ones to reserved bits. The value read from a reserved bit is not defined.	-
1	FUFRIS	FIFO underflow raw interrupt status. Set when either the upper or lower DMA FIFOs have been read accessed when empty causing an underflow condition to occur. Generates an interrupt if the FUFIM bit in the INTMSK register is set.	
2	LNBURIS	LCD next address base update raw interrupt status. Mode dependent. Set when the current base address registers have been successfully updated by the next address registers. Signifies that a new next address can be loaded if double buffering is in use. Generates an interrupt if the LNBUIM bit in the INTMSK register is set.	0x0

Table 602. Raw Interrupt Status register (INTRAW, address 0x4000 8020) bit description

Bit	Symbol	Description	Reset value
3	VCOMPRIS	Vertical compare raw interrupt status. Set when one of the four vertical regions is reached, as selected by the LcdVComp bits in the CTRL register. Generates an interrupt if the VCompIM bit in the INTMSK register is set.	0x0
4	BERRAW	AHB master bus error raw interrupt status. Set when the AHB master interface receives a bus error response from a slave. Generates an interrupt if the BERIM bit in the INTMSK register is set.	0x0
31:5	-	Reserved, user software should not write ones to reserved bits. The value read from a reserved bit is not defined.	-

27.6.10 Masked Interrupt Status register

The INTSTAT register is Read-Only, and contains a bit-by-bit logical AND of the INTRAW register and the INTMASK register. A logical OR of all interrupts is provided to the system interrupt controller.

Table 603. Masked Interrupt Status register (INTSTAT, address 0x4000 8024) bit description

Bit	Symbol	Description	Reset value
0	-	Reserved, user software should not write ones to reserved bits. The value read from a reserved bit is not defined.	-
1	FUFMIS	FIFO underflow masked interrupt status. Set when the both the FUFRRIS bit in the INTRAW register and the FUFIM bit in the INTMSK register are set.	0x0
2	LNBUMIS	LCD next address base update masked interrupt status. Set when the both the LNBURIS bit in the INTRAW register and the LNBUIM bit in the INTMSK register are set.	0x0
3	VCOMPMS	Vertical compare masked interrupt status. Set when the both the VCompRIS bit in the INTRAW register and the VCompIM bit in the INTMSK register are set.	0x0
4	BERMIS	AHB master bus error masked interrupt status. Set when the both the BERRAW bit in the INTRAW register and the BERIM bit in the INTMSK register are set.	0x0
31:5	-	Reserved, user software should not write ones to reserved bits. The value read from a reserved bit is not defined.	-

27.6.11 Interrupt Clear register

The INTCLR register is Write-Only. Writing a logic 1 to the relevant bit clears the corresponding interrupt.

Table 604. Interrupt Clear register (INTCLR, address 0x4000 8028) bit description

Bit	Symbol	Description	Reset value
0	-	Reserved, user software should not write ones to reserved bits. The value read from a reserved bit is not defined.	-
1	FUFIC	FIFO underflow interrupt clear. Writing a 1 to this bit clears the FIFO underflow interrupt.	0x0
2	LNBUIC	LCD next address base update interrupt clear. Writing a 1 to this bit clears the LCD next address base update interrupt.	0x0
3	VCOMPIC	Vertical compare interrupt clear. Writing a 1 to this bit clears the vertical compare interrupt.	0x0
4	BERIC	AHB master error interrupt clear. Writing a 1 to this bit clears the AHB master error interrupt.	0x0
31:5	-	Reserved, user software should not write ones to reserved bits. The value read from a reserved bit is not defined.	-

27.6.12 Upper Panel Current Address register

The UPCURR register is Read-Only, and contains an approximate value of the upper panel data DMA address when read.

Note: This register can change at any time and therefore can only be used as a rough indication of display position.

Table 605. Upper Panel Current Address register (UPCURR, address 0x4000 802C) bit description

Bit	Symbol	Description	Reset value
31:0	LCDUPCURR	LCD Upper Panel Current Address. Contains the current LCD upper panel data DMA address.	0x0

27.6.13 Lower Panel Current Address register

The LPCURR register is Read-Only, and contains an approximate value of the lower panel data DMA address when read.

Note: This register can change at any time and therefore can only be used as a rough indication of display position.

Table 606. Lower Panel Current Address register (LPCURR, address 0x4000 8030) bit description

Bit	Symbol	Description	Reset value
31:0	LCDLPCURR	LCD Lower Panel Current Address. Contains the current LCD lower panel data DMA address.	0x0

27.6.14 Color Palette registers

The PAL register contain 256 palette entries organized as 128 locations of two entries per word.

Each word location contains two palette entries. This means that 128 word locations are used for the palette. When configured for little-endian byte ordering, bits [15:0] are the lower numbered palette entry and [31:16] are the higher numbered palette entry. When configured for big-endian byte ordering this is reversed, because bits [31:16] are the low numbered palette entry and [15:0] are the high numbered entry.

Note: Only TFT displays use all of the palette entry bits.

Table 607. Color Palette registers (PAL, address 0x4000 8200 (PAL0) to 0x4000 83FC (PAL255)) bit description

Bit	Symbol	Description	Reset value
4:0	R04_0	Red palette data. For STN displays, only the four MSBs, bits [4:1], are used. For monochrome displays only the red palette data is used. All of the palette registers have the same bit fields.	0x0
9:5	G04_0	Green palette data.	0x0
14:10	B04_0	Blue palette data.	0x0
15	I0	Intensity / unused bit. Can be used as the LSB of the R, G, and B inputs to a 6:6:6 TFT display, doubling the number of colors to 64K, where each color has two different intensities.	0x0
20:16	R14_0	Red palette data. For STN displays, only the four MSBs, bits [4:1], are used. For monochrome displays only the red palette data is used. All of the palette registers have the same bit fields.	0x0
25:21	G14_0	Green palette data.	0x0
30:26	B14_0	Blue palette data.	0x0
31	I1	Intensity / unused bit. Can be used as the LSB of the R, G, and B inputs to a 6:6:6 TFT display, doubling the number of colors to 64K, where each color has two different intensities.	0x0

27.6.15 Cursor Image registers

The CRSR_IMG register area contains 256-word wide values which are used to define the image or images overlaid on the display by the hardware cursor mechanism. The image must always be stored in LBBP mode (little-endian byte, big-endian pixel) mode, as described in [Section 27.7.5.6](#). Two bits are used to encode color and transparency for each pixel in the cursor.

Depending on the state of bit 0 in the CRSR_CFG register (see Cursor Configuration register description), the cursor image RAM contains either four 32x32 cursor images, or a single 64x64 cursor image.

The two colors defined for the cursor are mapped onto values from the CRSR_PAL0 and CRSR_PAL0 registers (see Cursor Palette register descriptions).

Table 608. Cursor Image registers (CRSR_IMG, address 0x4000 8800 (CRSR_IMG0) to 0x4000 8BFC (CRSR_IMG255)) bit description

Bit	Symbol	Description	Reset value
31:0	CRSR_IMG	Cursor Image data. The 256 words of the cursor image registers define the appearance of either one 64x64 cursor or 4 32x32 cursors.	0x0

27.6.16 Cursor Control register

The CRSR_CTRL register provides access to frequently used cursor functions, such as the display on/off control for the cursor, and the cursor number.

If a 32x32 cursor is selected, one of four 32x32 cursors can be enabled. The images each occupy one quarter of the image memory, with Cursor0 from location 0, followed by Cursor1 from address 0x100, Cursor2 from 0x200 and Cursor3 from 0x300. If a 64x64 cursor is selected only one cursor fits in the image buffer, and no selection is possible.

Similar frame synchronization rules apply to the cursor number as apply to the cursor coordinates. If CrsrFramesync is 1, the displayed cursor image is only changed during the vertical frame blanking period. If CrsrFrameSync is 0, the cursor image index is changed immediately, even if the cursor is currently being scanned.

Table 609. Cursor Control register (CRSR_CTRL, address 0x4000 8C00) bit description

Bit	Symbol	Description	Reset value
0	CRSRON	Cursor enable. 0 = Cursor is not displayed. 1 = Cursor is displayed.	0x0
3:1	-	Reserved, user software should not write ones to reserved bits. The value read from a reserved bit is not defined.	0x0
5:4	CRSRNUM1_0	Cursor image number. If the selected cursor size is 6x64, this field has no effect. If the selected cursor size is 32x32: 00 = Cursor0. 01 = Cursor1. 10 = Cursor2. 11 = Cursor3.	0x0
31:6	-	Reserved, user software should not write ones to reserved bits. The value read from a reserved bit is not defined.	0x0

27.6.17 Cursor Configuration register

The CRSR_CFG register provides overall configuration information for the hardware cursor.

Table 610. Cursor Configuration register (CRSR_CFG, address 0x4000 8C04) bit description

Bit	Symbol	Description	Reset value
0	CRSRSIZE	Cursor size selection. 0 = 32x32 pixel cursor. Allows for 4 defined cursors. 1 = 64x64 pixel cursor.	0x0
1	FRAMESYNC	Cursor frame synchronization type. 0 = Cursor coordinates are asynchronous. 1 = Cursor coordinates are synchronized to the frame synchronization pulse.	0x0
31:2	-	Reserved, user software should not write ones to reserved bits. The value read from a reserved bit is not defined.	-

27.6.18 Cursor Palette register 0

The cursor palette registers provide color palette information for the visible colors of the cursor. Color0 maps through CRSR_PAL0.

The register provides 24-bit RGB values that are displayed according to the abilities of the LCD panel in the same way as the frame-buffers palette output is displayed.

In monochrome STN mode, only the upper 4 bits of the Red field are used. In STN color mode, the upper 4 bits of the Red, Blue, and Green fields are used. In 24 bits per pixel mode, all 24 bits of the palette registers are significant.

Table 611. Cursor Palette register 0 (CRSR_PAL0, address 0x4000 8C08) bit description

Bit	Symbol	Description	Reset value
7:0	RED	Red color component	0x0
15:8	GREEN	Green color component	0x0
23:16	BLUE	Blue color component.	0x0
31:24	-	Reserved, user software should not write ones to reserved bits. The value read from a reserved bit is not defined.	-

27.6.19 Cursor Palette register 1

The cursor palette registers provide color palette information for the visible colors of the cursor. Color1 maps through CRSR_PAL1.

The register provides 24-bit RGB values that are displayed according to the abilities of the LCD panel in the same way as the frame-buffers palette output is displayed.

In monochrome STN mode, only the upper 4 bits of the Red field are used. In STN color mode, the upper 4 bits of the Red, Blue, and Green fields are used. In 24 bits per pixel mode, all 24 bits of the palette registers are significant.

Table 612. Cursor Palette register 1 (CRSR_PAL1, address 0x4000 8C0C) bit description

Bit	Symbol	Description	Reset value
7:0	RED	Red color component	0x0
15:8	GREEN	Green color component	0x0
23:16	BLUE	Blue color component.	0x0
31:24	-	Reserved, user software should not write ones to reserved bits. The value read from a reserved bit is not defined.	-

27.6.20 Cursor XY Position register

The CRSR_XY register defines the distance of the top-left edge of the cursor from the top-left side of the cursor overlay. Refer to the section on Cursor Clipping for more details.

If the FrameSync bit in the CRSR_CFG register is 0, the cursor position changes immediately, even if the cursor is currently being scanned. If Framesync is 1, the cursor position is only changed during the next vertical frame blanking period.

Table 613. Cursor XY Position register (CRSR_XY, address 0x4000 8C10) bit description

Bit	Symbol	Description	Reset value
9:0	CRSRX	X ordinate of the cursor origin measured in pixels. When 0, the left edge of the cursor is at the left of the display.	0x0
15:10	-	Reserved, user software should not write ones to reserved bits. The value read from a reserved bit is not defined.	-
25:16	CRSRY	Y ordinate of the cursor origin measured in pixels. When 0, the top edge of the cursor is at the top of the display.	0x0
31:26	-	Reserved, user software should not write ones to reserved bits. The value read from a reserved bit is not defined.	-

27.6.21 Cursor Clip Position register

The CRSR_CLIP register defines the distance from the top-left edge of the cursor image, to the first displayed pixel in the cursor image.

Different synchronization rules apply to the Cursor Clip registers than apply to the cursor coordinates. If the FrameSync bit in the CRSR_CFG register is 0, the cursor clip point is changed immediately, even if the cursor is currently being scanned.

If the Framesync bit in the CRSR_CFG register is 1, the displayed cursor image is only changed during the vertical frame blanking period, providing that the cursor position has been updated since the Clip register was programmed. When programming, the Clip register must be written before the Position register (ClcdCrsrXY) to ensure that in a given frame, the clip and position information is coherent.

Table 614. Cursor Clip Position register (CRSR_CLIP, address 0x4000 8C14) bit description

Bit	Symbol	Description	Reset value
5:0	CRSRCLIPX	Cursor clip position for X direction. Distance from the left edge of the cursor image to the first displayed pixel in the cursor. When 0, the first pixel of the cursor line is displayed.	0x0
7:6	-	Reserved, user software should not write ones to reserved bits. The value read from a reserved bit is not defined.	-
13:8	CRSRCLIPY	Cursor clip position for Y direction. Distance from the top of the cursor image to the first displayed pixel in the cursor. When 0, the first displayed pixel is from the top line of the cursor image.	0x0
31:14	-	Reserved, user software should not write ones to reserved bits. The value read from a reserved bit is not defined.	-

27.6.22 Cursor Interrupt Mask register

The CRSR_INTMSK register is used to enable or disable the cursor from interrupting the processor.

Table 615. Cursor Interrupt Mask register (CRSR_INTMSK, address 0x4000 8C20) bit description

Bit	Symbol	Description	Reset value
0	CRSRIM	Cursor interrupt mask. When clear, the cursor never interrupts the processor. When set, the cursor interrupts the processor immediately after reading of the last word of cursor image.	0x0
31:1	-	Reserved, user software should not write ones to reserved bits. The value read from a reserved bit is not defined.	-

27.6.23 Cursor Interrupt Clear register

The CRSR_INTCLR register is used by software to clear the cursor interrupt status and the cursor interrupt signal to the processor.

Table 616. Cursor Interrupt Clear register (CRSR_INTCLR, address 0x4000 8C24) bit description

Bit	Symbol	Description	Reset value
0	CRSRIC	Cursor interrupt clear. Writing a 0 to this bit has no effect. Writing a 1 to this bit causes the cursor interrupt status to be cleared.	0x0
31:1	-	Reserved, user software should not write ones to reserved bits. The value read from a reserved bit is not defined.	-

27.6.24 Cursor Raw Interrupt Status register

The CRSR_INTRAW register is set to indicate a cursor interrupt. When enabled via the CrsrIM bit in the CRSR_INTMSK register, provides the interrupt to the system interrupt controller.

Table 617. Cursor Raw Interrupt Status register (CRSR_INTRAW, address 0x4000 8C28) bit description

Bit	Symbol	Description	Reset value
0	CRSRRIS	Cursor raw interrupt status. The cursor interrupt status is set immediately after the last data is read from the cursor image for the current frame. This bit is cleared by writing to the CrsrIC bit in the CRSR_INTCLR register.	0x0
31:1	-	Reserved, user software should not write ones to reserved bits. The value read from a reserved bit is not defined.	-

27.6.25 Cursor Masked Interrupt Status register

The CRSR_INTSTAT register is set to indicate a cursor interrupt providing that the interrupt is not masked in the CRSR_INTMSK register.

Table 618. Cursor Masked Interrupt Status register (CRSR_INTSTAT, address 0x4000 8C2C) bit description

Bit	Symbol	Description	Reset value
0	CRSRMIS	Cursor masked interrupt status. The cursor interrupt status is set immediately after the last data read from the cursor image for the current frame, providing that the corresponding bit in the CRSR_INTMSK register is set. The bit remains clear if the CRSR_INTMSK register is clear. This bit is cleared by writing to the CRSR_INTCLR register.	0x0
31:1	-	Reserved, user software should not write ones to reserved bits. The value read from a reserved bit is not defined.	-

27.7 Functional description

27.7.1 AHB interfaces

The LCD controller includes two separate AHB interfaces. The first, an AHB slave interface, is used primarily by the CPU to access control and data registers within the LCD controller. The second, an AHB master interface, is used by the LCD controller for DMA access to display data stored in memory elsewhere in the system. The LCD DMA controller can access any SRAM on AHB and the external memory.

27.7.1.1 AMBA AHB slave interface

The AHB slave interface connects the LCD controller to the AHB bus and provides CPU accesses to the registers and palette RAM.

27.7.1.2 AMBA AHB master interface

The AHB master interface transfers display data from a selected slave (memory) to the LCD controller DMA FIFOs. It can be configured to obtain data from any on-chip SRAM on AHB, various types of off-chip static memory, or off-chip SDRAM.

In dual panel mode, the DMA FIFOs are filled up in an alternating fashion via a single DMA request. In single panel mode, the DMA FIFOs are filled up in a sequential fashion from a single DMA request.

The inherent AHB master interface state machine performs the following functions:

- Loads the upper panel base address into the AHB address incrementer on recognition of a new frame.
- Monitors both the upper and lower DMA FIFO levels and asserts a DMA request to request display data from memory, filling them to above the programmed watermark. the DMA request is reasserted when there are at least four locations available in either FIFO (dual panel mode).
- Checks for 1 kB boundaries during fixed-length bursts, appropriately adjusting the address in such occurrences.
- Generates the address sequences for fixed-length and undefined bursts.
- Controls the handshaking between the memory and DMA FIFOs. It inserts busy cycles if the FIFOs have not completed their synchronization and updating sequence.
- Fills up the DMA FIFOs, in dual panel mode, in an alternating fashion from a single DMA request.
- Asserts the a bus error interrupt if an error occurs during an active burst.
- Responds to retry commands by restarting the failed access. This introduces some busy cycles while it re-synchronizes.

27.7.2 Dual DMA FIFOs and associated control logic

The pixel data accessed from memory is buffered by two DMA FIFOs that can be independently controlled to cover single and dual-panel LCD types. Each FIFO is 16 words deep by 64 bits wide and can be cascaded to form an effective 32-Dword deep FIFO in single panel mode.

Synchronization logic transfers the pixel data from the AHB clock domain to the LCD controller clock domain. The water level marks in each FIFO are set such that each FIFO requests data when at least four locations become available.

An interrupt signal is asserted if an attempt is made to read either of the two DMA FIFOs when they are empty (an underflow condition has occurred).

27.7.3 Pixel serializer

This block reads the 32-bit wide LCD data from the output port of the DMA FIFO and extracts 24, 16, 8, 4, 2, or 1 bpp data, depending on the current mode of operation. The LCD controller supports big-endian, little-endian, and Windows CE data formats.

Depending on the mode of operation, the extracted data can be used to point to a color or gray scale value in the palette RAM or can actually be a true color value that can be directly applied to an LCD panel input.

Table 619 through Table 621 show the structure of the data in each DMA FIFO word corresponding to the endianness and bpp combinations. For each of the three supported data formats, the required data for each panel display pixel must be extracted from the data word.

Table 619. FIFO bits for Little-endian Byte, Little-endian Pixel order

FIFO bit	1 bpp	2 bpp	4 bpp	8 bpp	16 bpp	24 bpp
31	p31	p15	p7	p3	p1	p0
30	p30					
29	p29	p14				
28	p28					
27	p27	p13	p6			
26	p26					
25	p25			p12		
24	p24					
23	p23	p11	p5	p2		
22	p22					
21	p21	p10				
20	p20					
19	p19	p9	p4			
18	p18					
17	p17			p8		
16	p16					
15	p15	p7	p3	p1		
14	p14					
13	p13	p6			p2	
12	p12					
11	p11	p5	p1			
10	p10					
9	p9	p4	p2			
8	p8					
7	p7	p3	p1			
6	p6					
5	p5	p2		p0		
4	p4					
3	p3	p1	p0			
2	p2					
1	p1	p0				
0	p0					

Table 620. FIFO bits for Big-endian Byte, Big-endian Pixel order

FIFO bit	1 bpp	2 bpp	4 bpp	8 bpp	16 bpp	24 bpp
31	p0	p0	p0	p0	p0	p0
30	p1					
29	p2	p1				
28	p3					
27	p4	p2	p1			
26	p5					
25	p6					
24	p7	p3	p1			
23	p8					
22	p9	p4				
21	p10					
20	p11					
19	p12	p5		p2		
18	p13					
17	p14	p6			p3	
16	p15					
15	p16	p7	p4			
14	p17					
13	p18					
12	p19	p8		p5		
11	p20					
10	p21	p9	p6			
9	p22					
8	p23					
7	p24	p10		p7		
6	p25					
5	p26	p11			p8	
4	p27					
3	p28					
2	p29	p12	p9			
1	p30					
0	p31	p13		p10		

Table 621. FIFO bits for Little-endian Byte, Big-endian Pixel order

FIFO bit	1 bpp	2 bpp	4 bpp	8 bpp	16 bpp	24 bpp
31	p24	p12	p6	p3	p1	p0
30	p25					
29	p26	p13				
28	p27					
27	p28	p14	p7			
26	p29					
25	p30					
24	p31	p15				
23	p16		p8			
22	p17					
21	p18	p9		p4		
20	p19					
19	p20	p10	p2			
18	p21					
17	p22					
16	p23	p11		p5		
15	p8				p4	
14	p9					
13	p10	p5	p1			
12	p11					
11	p12	p6		p3		
10	p13					
9	p14					
8	p15	p7		p0		
7	p0		p0			
6	p1					
5	p2	p1				
4	p3					
3	p4	p2				
2	p5					
1	p6		p3			
0	p7					

[Table 622](#) shows the structure of the data in each DMA FIFO word in RGB mode.

Table 622. RGB mode data formats

FIFO data	24-bit RGB	16-bit (1:5:5:5 RGB)	16-bit (5:6:5 RGB)	16-bit (4:4:4 RGB)
31	-	p1 intensity bit	p1, Blue 4	-
30	-	p1, Blue 4	p1, Blue 3	-
29	-	p1, Blue 3	p1, Blue 2	-
28	-	p1, Blue 2	p1, Blue 1	-
27	-	p1, Blue 1	p1, Blue 0	p1, Blue 3
26	-	p1, Blue 0	p1, Green 5	p1, Blue 2
25	-	p1, Green 4	p1, Green 4	p1, Blue 1
24	-	p1, Green 3	p1, Green 3	p1, Blue 0
23	p0, Blue 7	p1, Green 2	p1, Green 2	p1, Green 3
22	p0, Blue 6	p1, Green 1	p1, Green 1	p1, Green 2
21	p0, Blue 5	p1, Green 0	p1, Green 0	p1, Green 1
20	p0, Blue 4	p1, Red 4	p1, Red 4	p1, Green 0
19	p0, Blue 3	p1, Red 3	p1, Red 3	p1, Red 3
18	p0, Blue 2	p1, Red 2	p1, Red 2	p1, Red 2
17	p0, Blue 1	p1, Red 1	p1, Red 1	p1, Red 1
16	p0, Blue 0	p1, Red 0	p1, Red 0	p1, Red 0
15	p0, Green 7	p0 intensity bit	p0, Blue 4	-
14	p0, Green 6	p0, Blue 4	p0, Blue 3	-
13	p0, Green 5	p0, Blue 3	p0, Blue 2	-
12	p0, Green 4	p0, Blue 2	p0, Blue 1	-
11	p0, Green 3	p0, Blue 1	p0, Blue 0	p0, Blue 3
10	p0, Green 2	p0, Blue 0	p0, Green 5	p0, Blue 2
9	p0, Green 1	p0, Green 4	p0, Green 4	p0, Blue 1
8	p0, Green 0	p0, Green 3	p0, Green 3	p0, Blue 0
7	p0, Red 7	p0, Green 2	p0, Green 2	p0, Green 3
6	p0, Red 6	p0, Green 1	p0, Green 1	p0, Green 2
5	p0, Red 5	p0, Green 0	p0, Green 0	p0, Green 1
4	p0, Red 4	p0, Red 4	p0, Red 4	p0, Green 0
3	p0, Red 3	p0, Red 3	p0, Red 3	p0, Red 3
2	p0, Red 2	p0, Red 2	p0, Red 2	p0, Red 2
1	p0, Red 1	p0, Red 1	p0, Red 1	p0, Red 1
0	p0, Red 0	p0, Red 0	p0, Red 0	p0, Red 0

27.7.4 RAM palette

The RAM-based palette is a 256 x 16 bit dual-port RAM physically structured as 128 x 32 bits. Two entries can be written into the palette from a single word write access. The Least Significant Bit (LSB) of the serialized pixel data selects between upper and lower halves of the palette RAM. The half that is selected depends on the byte ordering mode. In little-endian mode, setting the LSB selects the upper half, but in big-endian mode, the lower half of the palette is selected.

Pixel data values can be written and verified through the AHB slave interface. For information on the supported colors, refer to the section on the related panel type earlier in this chapter.

The palette RAM is a dual port RAM with independent controls and addresses for each port. Port1 is used as a read/write port and is connected to the AHB slave interface. The palette entries can be written and verified through this port. Port2 is used as a read-only port and is connected to the unpacker and gray scaler. For color modes of less than 16 bpp, the palette enables each pixel value to be mapped to a 16-bit color:

- For TFT displays, the 16-bit value is passed directly to the pixel serializer.
- For STN displays, the 16-bit value is first converted by the gray scaler.

[Table 623](#) shows the bit representation of the palette data. The palette 16-bit output uses the TFT 1:5:5:5 data format. In 16 and 24 bpp TFT mode, the palette is bypassed and the output of the pixel serializer is used as the TFT panel data.

Table 623. Palette data storage for TFT modes.

Bit(s)	Name (RGB format)	Description (RGB format)	Name (BGR format)	Description (BGR format)
31	I	Intensity / unused	I	Intensity / unused
30:26	B[4:0]	Blue palette data	R[4:0]	Red palette data
25:21	G[4:0]	Green palette data	G[4:0]	Green palette data
20:16	R[4:0]	Red palette data	B[4:0]	Blue palette data
15	I	Intensity / unused	I	Intensity / unused
14:10	B[4:0]	Blue palette data	R[4:0]	Red palette data
9:5	G[4:0]	Green palette data	G[4:0]	Green palette data
4:0	R[4:0]	Red palette data	B[4:0]	Blue palette data

The red and blue pixel data can be swapped to support BGR data format using a control register bit (bit 8 = BGR). See the CTRL register description for more information.

[Table 624](#) shows the bit representation of the palette data for the STN color modes.

Table 624. Palette data storage for STN color modes.

Bit(s)	Name (RGB format)	Description (RGB format)	Name (BGR format)	Description (BGR format)
31	-	Unused	-	Unused
30:27	B[3:0]	Blue palette data	R[3:0]	Red palette data
26	-	Unused	-	Unused
25:22	G[3:0]	Green palette data	G[3:0]	Green palette data
21	-	Unused	-	Unused
20:17	R[3:0]	Red palette data	B[3:0]	Blue palette data
16	-	Unused	-	Unused
15	I	Unused	I	Unused
14:11	B[4:1]	Blue palette data	R[4:1]	Red palette data
10	B[0]	Unused	R[0]	Unused
9:6	G[4:1]	Green palette data	G[4:1]	Green palette data

Table 624. Palette data storage for STN color modes.

Bit(s)	Name (RGB format)	Description (RGB format)	Name (BGR format)	Description (BGR format)
5	G[0]	Unused	G[0]	Unused
4:1	R[4:1]	Red palette data	B[4:1]	Blue palette data
0	R[0]	Unused	B[0]	Unused

For monochrome STN mode, only the red palette field bits [4:1] are used. However, in STN color mode the green and blue [4:1] are also used. Only 4 bits per color are used, because the gray scaler only supports 16 different shades per color.

[Table 625](#) shows the bit representation of the palette data for the STN monochrome mode.

Table 625. Palette data storage for STN monochrome mode.

Bit(s)	Name	Description
31	-	Unused
30:27	-	Unused
26	-	Unused
25:22	-	Unused
21	-	Unused
20:17	Y[3:0]	Intensity data
16	-	Unused
15	-	Unused
14:11	-	Unused
10	-	Unused
9:6	-	Unused
5	-	Unused
4:1	Y[3:0]	Intensity data
0	-	Unused

27.7.5 Hardware cursor

The hardware cursor is an integral part of the LCD controller. It uses the LCD timing module to provide an indication of the current scan position coordinate, and intercepts the pixel stream between the palette logic and the gray scale/output multiplexer.

All cursor programming registers are accessed through the LCD slave interface. This also provides a read/write port to the cursor image RAM.

27.7.5.1 Cursor operation

The hardware cursor is contained in a dual port RAM. It is programmed by software through the AHB slave interface. The AHB slave interface also provides access to the hardware cursor control registers. These registers enable you to modify the cursor position and perform various other functions.

When enabled, the hardware cursor uses the horizontal and vertical synchronization signals, along with a pixel clock enable and various display parameters to calculate the current scan coordinate.

When the display point is inside the bounds of the cursor image, the cursor replaces frame buffer pixels with cursor pixels.

When the last cursor pixel is displayed, an interrupt is generated that software can use as an indication that it is safe to modify the cursor image. This enables software controlled animations to be performed without flickering for frame synchronized cursors.

27.7.5.2 Cursor sizes

Two cursor sizes are supported, as shown in [Table 626](#).

Table 626. Palette data storage for STN monochrome mode.

X Pixels	Y Pixels	Bits per pixel	Words per line	Words in cursor image
32	32	2	2	64
64	64	2	4	256

27.7.5.3 Cursor movement

The following descriptions assume that both the screen and cursor origins are at the top left of the visible screen (the first visible pixel scanned each frame). [Figure 80](#) shows how each pixel coordinate is assumed to be the top left corner of the pixel.

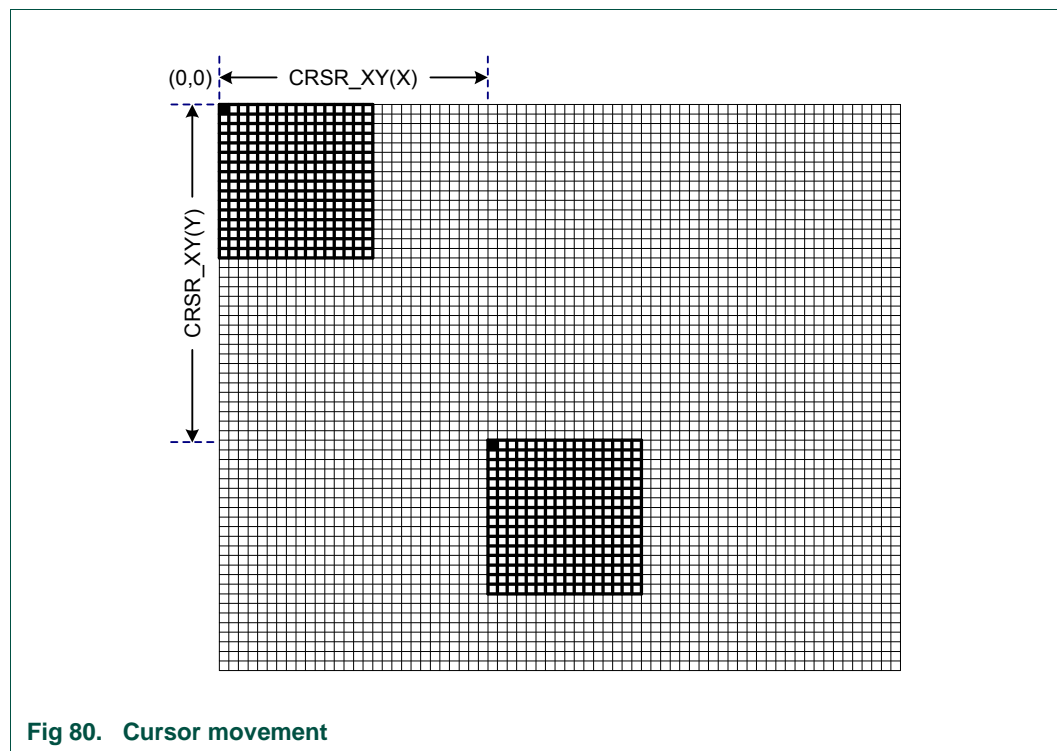

Fig 80. Cursor movement

27.7.5.4 Cursor XY positioning

The $CRSR_XY$ register controls the cursor position on the cursor overlay (see Cursor XY Position register). This provides separate fields for X and Y ordinates.

The $CRSR_CFG$ register (see Cursor Configuration register) provides a FrameSync bit controlling the visible behavior of the cursor.

With FrameSync inactive, the cursor responds immediately to any change in the programmed CRSR_XY value. Some transient smearing effects may be visible if the cursor is moved across the LCD scan line.

With FrameSync active, the cursor only updates its position after a vertical synchronization has occurred. This provides clean cursor movement, but the cursor position only updates once a frame.

27.7.5.5 Cursor clipping

The CRSR_XY register (see Cursor XY Position register) is programmed with positive binary values that enable the cursor image to be located anywhere on the visible screen image. The cursor image is clipped automatically at the screen limits when it extends beyond the screen image to the right or bottom (see X1,Y1 in [Figure 81](#)). The checked pattern shows the visible portion of the cursor.

Because the CRSR_XY register values are positive integers, to emulate cursor clipping on the left and top of screen, a Clip Position register, CRSR_CLIP, is provided. This controls which point of the cursor image is positioned at the CRSR_CLIP coordinate. For clipping functions on the Y axis, CRSR_XY(X) is zero, and Clip(X) is programmed to provide the offset into the cursor image (X2 and X3). The equivalent function is provided to clip on the X axis at the top of the display (Y2).

For cursors that are not clipped at the X=0 or Y=0 lines, program the Clip Position register X and Y fields with zero to display the cursor correctly. See Clip(X4,Y4) for the effect of incorrect programming.

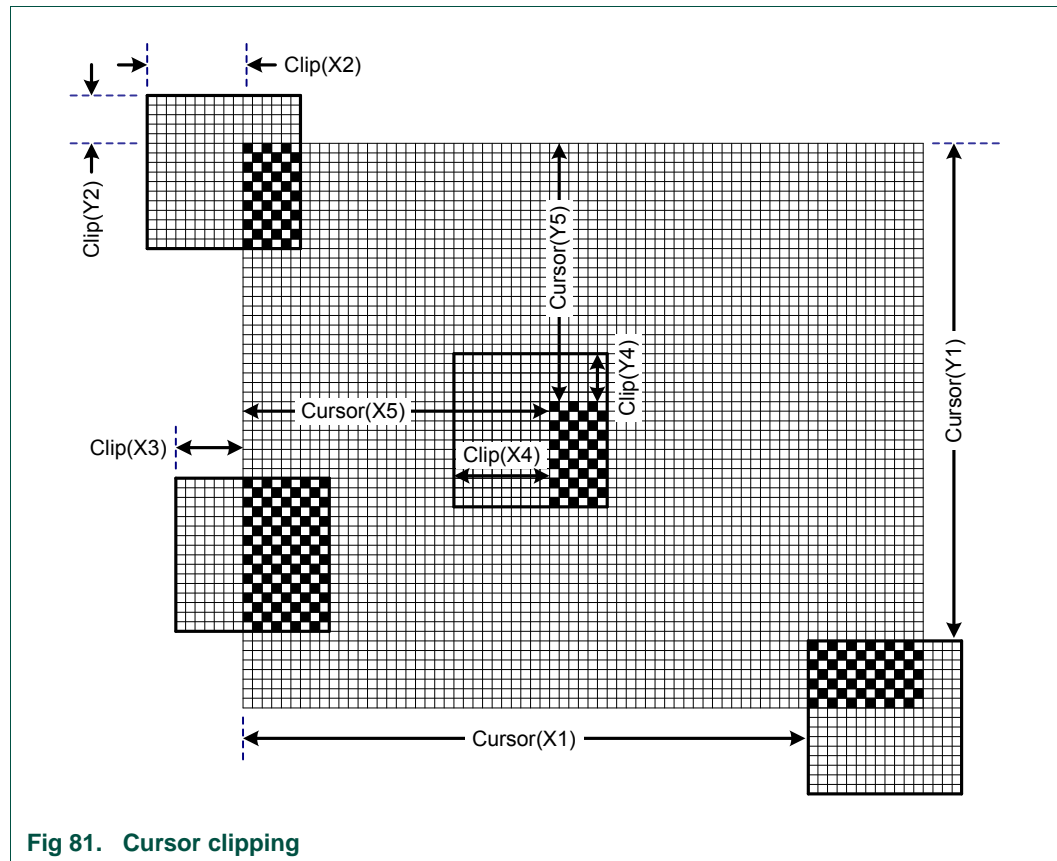

Fig 81. Cursor clipping

27.7.5.6 Cursor image format

The LCD frame buffer supports three packing formats, but the hardware cursor image requirement has been simplified to support only LBBP. This is little-endian byte, big-endian pixel for Windows CE mode.

The Image RAM start address is offset by 0x800 from the LCD base address, as shown in the register description in this chapter.

The displayed cursor coordinate system is expressed in terms of (X,Y). 64 x 64 is an extension of the 32 x 32 format shown in [Figure 82](#).

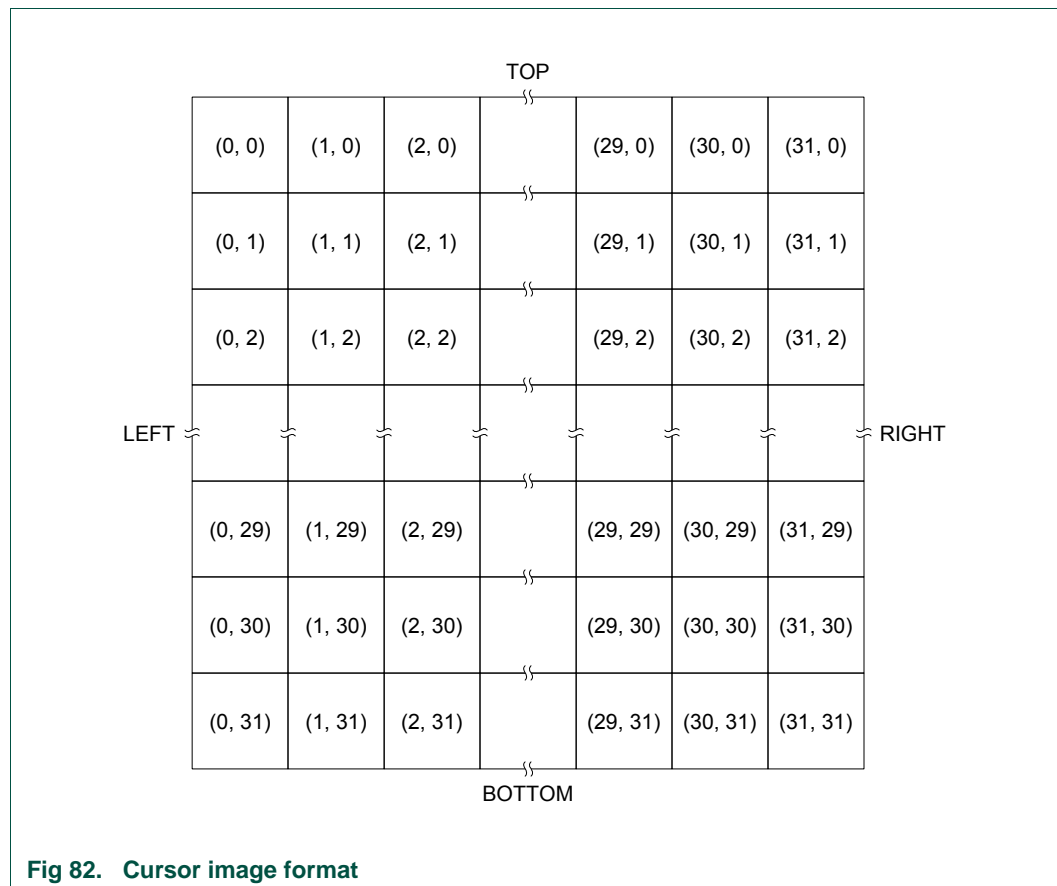

Fig 82. Cursor image format

32 by 32 pixel format

Four cursors are held in memory, each with the same pixel format. [Table 627](#) lists the base addresses for the four cursors.

Table 627. Addresses for 32 x 32 cursors

Address	Description
0x4000 8800	Cursor 0 start address.
0x4000 8900	Cursor 1 start address.
0x4000 8A00	Cursor 2 start address.
0x4000 8B00	Cursor 3 start address.

[Table 628](#) shows the buffer to pixel mapping for Cursor 0.

Table 628. Buffer to pixel mapping for 32 x 32 pixel cursor format

Data bits	Offset into cursor memory					
	0	4	(8 * y)	(8 * y) +4	F8	FC
31:30	(12, 0)	(28, 0)	(12, y)	(28, y)	(12, 31)	(28,31)
29:28	(13, 0)	(29, 0)	(13, y)	(29, y)	(13, 31)	(29, 31)
27:26	(14, 0)	(30, 0)	(14, y)	(30, y)	(14, 31)	(30, 31)
25:24	(15, 0)	(31, 0)	(15, y)	(31, y)	(15, 31)	(31, 31)
23:22	(8, 0)	(24, 0)	(8, y)	(24, y)	(8, 31)	(24, 31)
21:20	(9, 0)	(25, 0)	(9, y)	(25, y)	(9, 31)	(25, 31)
19:18	(10, 0)	(26, 0)	(10, y)	(26, y)	(10, 31)	(26, 31)
17:16	(11, 0)	(27, 0)	(11, y)	(27, y)	(11, 31)	(27, 31)
15:14	(4, 0)	(20, 0)	(4, y)	(20, y)	(4, 31)	(20, 31)
13:12	(5, 0)	(21, 0)	(5, y)	(21, y)	(5, 31)	(21, 31)
11:10	(6, 0)	(22, 0)	(6, y)	(22, y)	(6, 31)	(22, 31)
9:8	(7, 0)	(23, 0)	(7, y)	(23, y)	(7, 31)	(23, 31)
7:6	(0, 0)	(16, 0)	(0, y)	(16, y)	(0, 31)	(16, 31)
5:4	(1, 0)	(17, 0)	(1, y)	(17, y)	(1, 31)	(17, 31)
3:2	(2, 0)	(18, 0)	(2, y)	(18, y)	(2, 31)	(18, 31)
1:0	(3, 0)	(19, 0)	(3, y)	(19, y)	(3, 31)	(19, 31)

64 by 64 pixel format

Only one cursor fits in the memory space in 64 x 64 mode. [Table 629](#) shows the 64 x 64 cursor format.

Table 629. Buffer to pixel mapping for 64 x 64 pixel cursor format

Data bits	Offset into cursor memory								
	0	4	8	12	(16 * y)	(16 * y) +4	(16 * y) + 8	(16 * y) + 12	FC
31:30	(12, 0)	(28, 0)	(44, 0)	(60, 0)	(12, y)	(28, y)	(44, y)	(60, y)	(60, 63)
29:28	(13, 0)	(29, 0)	(45, 0)	(61, 0)	(13, y)	(29, y)	(45, y)	(61, y)	(61, 63)
27:26	(14, 0)	(30, 0)	(46, 0)	(62, 0)	(14, y)	(30, y)	(46, y)	(62, y)	(62, 63)
25:24	(15, 0)	(31, 0)	(47, 0)	(63, 0)	(15, y)	(31, y)	(47, y)	(63, y)	(63, 63)
23:22	(8, 0)	(24, 0)	(40, 0)	(56, 0)	(8, y)	(24, y)	(40, y)	(56, y)	(56, 63)
21:20	(9, 0)	(25, 0)	(41, 0)	(57, 0)	(9, y)	(25, y)	(41, y)	(57, y)	(57, 63)
19:18	(10, 0)	(26, 0)	(42, 0)	(58, 0)	(10, y)	(26, y)	(42, y)	(58, y)	(58, 63)
17:16	(11, 0)	(27, 0)	(43, 0)	(59, 0)	(11, y)	(27, y)	(43, y)	(59, y)	(59, 63)
15:14	(4, 0)	(20, 0)	(36, 0)	(52, 0)	(4, y)	(20, y)	(36, y)	(52, y)	(52, 63)
13:12	(5, 0)	(21, 0)	(37, 0)	(53, 0)	(5, y)	(21, y)	(37, y)	(53, y)	(53, 63)
11:10	(6, 0)	(22, 0)	(38, 0)	(54, 0)	(6, y)	(22, y)	(38, y)	(54, y)	(54, 63)
9:8	(7, 0)	(23, 0)	(39, 0)	(55, 0)	(7, y)	(23, y)	(39, y)	(55, y)	(55, 63)
7:6	(0, 0)	(16, 0)	(32, 0)	(48, 0)	(0, y)	(16, y)	(32, y)	(48, y)	(48, 63)

Table 629. Buffer to pixel mapping for 64 x 64 pixel cursor format

Data bits	Offset into cursor memory								
	0	4	8	12	(16 * y)	(16 * y) + 4	(16 * y) + 8	(16 * y) + 12	FC
5:4	(1, 0)	(17, 0)	(33, 0)	(49, 0)	(1, y)	(17, y)	(33, y)	(49, y)	(49, 63)
3:2	(2, 0)	(18, 0)	(34, 0)	(50, 0)	(2, y)	(18, y)	(34, y)	(50, y)	(50, 63)
1:0	(3, 0)	(19, 0)	(35, 0)	(51, 0)	(3, y)	(19, y)	(35, y)	(51, y)	(51, 63)

Cursor pixel encoding

Each pixel of the cursor requires two bits of information. These are interpreted as Color0, Color1, Transparent, and Transparent inverted.

In the coding scheme, bit 1 selects between color and transparent (AND mask) and bit 0 selects variant (XOR mask).

[Table 630](#) shows the pixel encoding bit assignments.

Table 630. Pixel encoding

Value	Description
00	Color0. The cursor color is displayed according to the Red-Green-Blue (RGB) value programmed into the CRSR_PAL0 register.
01	Color1. The cursor color is displayed according to the RGB value programmed into the CRSR_PAL1 register.
10	Transparent. The cursor pixel is transparent, so is displayed unchanged. This enables the visible cursor to assume shapes that are not square.
11	Transparent inverted. The cursor pixel assumes the complementary color of the frame pixel that is displayed. This can be used to ensure that the cursor is visible regardless of the color of the frame buffer image.

27.7.6 Gray scaler

A patented gray scale algorithm drives monochrome and color STN panels. This provides 15 gray scales for monochrome displays. For STN color displays, the three color components (RGB) are gray scaled simultaneously. This results in 3375 (15x15x15) colors being available. The gray scaler transforms each 4-bit gray value into a sequence of activity-per-pixel over several frames, relying to some degree on the display characteristics, to give the representation of gray scales and color.

27.7.7 Upper and lower panel formatters

Formatters are used in STN mode to convert the gray scaler output to a parallel format as required by the display. For monochrome displays, this is either 4 or 8 bits wide, and for color displays, it is 8 bits wide. [Table 631](#) shows a color display driven with 2 2/3 pixels worth of data in a repeating sequence.

Table 631. Color display driven with 2 2/3 pixel data

Byte	CLD[7]	CLD[6]	CLD[5]	CLD[4]	CLD[3]	CLD[2]	CLD[1]	CLD[0]
0	P2[Green]	P2[Red]	P1[Blue]	P1[Green]	P1[Red]	P0[Blue]	P0[Green]	P0[Red]
1	P5[Red]	P4q[Blue]	P4[Green]	P4[Red]	P3[Blue]	P3[Green]	P3[Red]	P2[Blue]
2	P7[Blue]	P7[Green]	P7[Red]	P6[Blue]	P6[Green]	P6[Red]	P5[Blue]	P5[Green]

Each formatter consists of three 3-bit (RGB) shift left registers. RGB pixel data bit values from the gray scaler are concurrently shifted into the respective registers. When enough data is available, a byte is constructed by multiplexing the registered data to the correct bit position to satisfy the RGB data pattern of LCD panel. The byte is transferred to the 3-byte FIFO, which has enough space to store eight color pixels.

27.7.8 Panel clock generator

The output of the panel clock generator block is the panel clock, pin LCDDCLK. The panel clock can be based on either the peripheral clock for the LCD block or the external clock input for the LCD, pin LCDCLKIN. Whichever source is selected can be divided down in order to produce the internal LCD clock, LCDCLK.

The panel clock generator can be programmed to output the LCD panel clock in the range of LCDCLK/2 to LCDCLK/1025 to match the bpp data rate of the LCD panel being used.

The CLKSEL bit in the POL register determines whether the base clock used is CCLK or the LCDCLKIN pin.

27.7.9 Timing controller

The primary function of the timing controller block is to generate the horizontal and vertical timing panel signals. It also provides the panel bias and enable signals. These timings are all register-programmable.

27.7.10 STN and TFT data select

Support is provided for passive Super Twisted Nematic (STN) and active Thin Film Transistor (TFT) LCD display types:

27.7.10.1 STN displays

STN display panels require algorithmic pixel pattern generation to provide pseudo gray scaling on monochrome displays, or color creation on color displays.

27.7.10.2 TFT displays

TFT display panels require the digital color value of each pixel to be applied to the display data inputs.

27.7.11 Interrupt generation

Four interrupts are generated by the LCD controller, and a single combined interrupt. The four interrupts are:

- Master bus error interrupt.
- Vertical compare interrupt.

- Next base address update interrupt.
- FIFO underflow interrupt.

Each of the four individual maskable interrupts is enabled or disabled by changing the mask bits in the INT_MSK register. These interrupts are also combined into a single overall interrupt, which is asserted if any of the individual interrupts are both asserted and unmasked. Provision of individual outputs in addition to a combined interrupt output enables use of either a global interrupt service routine, or modular device drivers to handle interrupts.

The status of the individual interrupt sources can be read from the INTRAW register.

27.7.11.1 Master bus error interrupt

The master bus error interrupt is asserted when an ERROR response is received by the master interface during a transaction with a slave. When such an error is encountered, the master interface enters an error state and remains in this state until clearance of the error has been signaled to it. When the respective interrupt service routine is complete, the master bus error interrupt may be cleared by writing a 1 to the BERIC bit in the INTCLR register. This action releases the master interface from its ERROR state to the start of FRAME state, and enables fresh frame of data display to be initiated.

27.7.11.2 Vertical compare interrupt

The vertical compare interrupt asserts when one of four vertical display regions, selected using the CTRL register, is reached. The interrupt can be made to occur at the start of:

- Vertical synchronization.
- Back porch.
- Active video.
- Front porch.

The interrupt may be cleared by writing a 1 to the VcompIC bit in the INTCLR register.

27.7.11.2.1 Next base address update interrupt

The LCD next base address update interrupt asserts when either the LCDUPBASE or LCDLPBASE values have been transferred to the LCDUPCURR or LCDLPCURR incrementers respectively. This signals to the system that it is safe to update the LCDUPBASE or the LCDLPBASE registers with new frame base addresses if required.

The interrupt can be cleared by writing a 1 to the LNBUIC bit in the INTCLR register

27.7.11.2.2 FIFO underflow interrupt

The FIFO underflow interrupt asserts when internal data is requested from an empty DMA FIFO. Internally, upper and lower panel DMA FIFO underflow interrupt signals are generated.

The interrupt can be cleared by writing a 1 to the FUFIC bit in the INTCLR register.

27.7.12 LCD power-up and power-down sequence

The LCD controller requires the following power-up sequence to be performed:

1. When power is applied, the following signals are held LOW:

- LCDLP
- LCDDCLK
- LCDFP
- LCDENAB/ LCDM
- LCDVD[23:0]
- LCDLE

2. When LCD power is stabilized, a 1 is written to the LcdEn bit in the CTRL register. This enables the following signals into their active states:

- LCDLP
- LCDDCLK
- LCDFP
- LCDENAB/ LCDM
- LCDLE

The LCDV[23:0] signals remain in an inactive state.

3. When the signals in step 2 have stabilized, the contrast voltage (not controlled or supplied by the LCD controller) is applied to the LCD panel.

4. If required, a software or hardware timer can be used to provide the minimum display specific delay time between application of the control signals and power to the panel display. On completion of the time interval, power is applied to the panel by writing a 1 to the LcdPwr bit within the CTRL register that, in turn, sets the LCDPWR signal high and enables the LCDV[23:0] signals into their active states. The LCDPWR signal is intended to be used to gate the power to the LCD panel.

The power-down sequence is the reverse of the above four steps and must be strictly followed, this time, writing the respective register bits with 0.

[Figure 83](#) shows the power-up and power-down sequences.

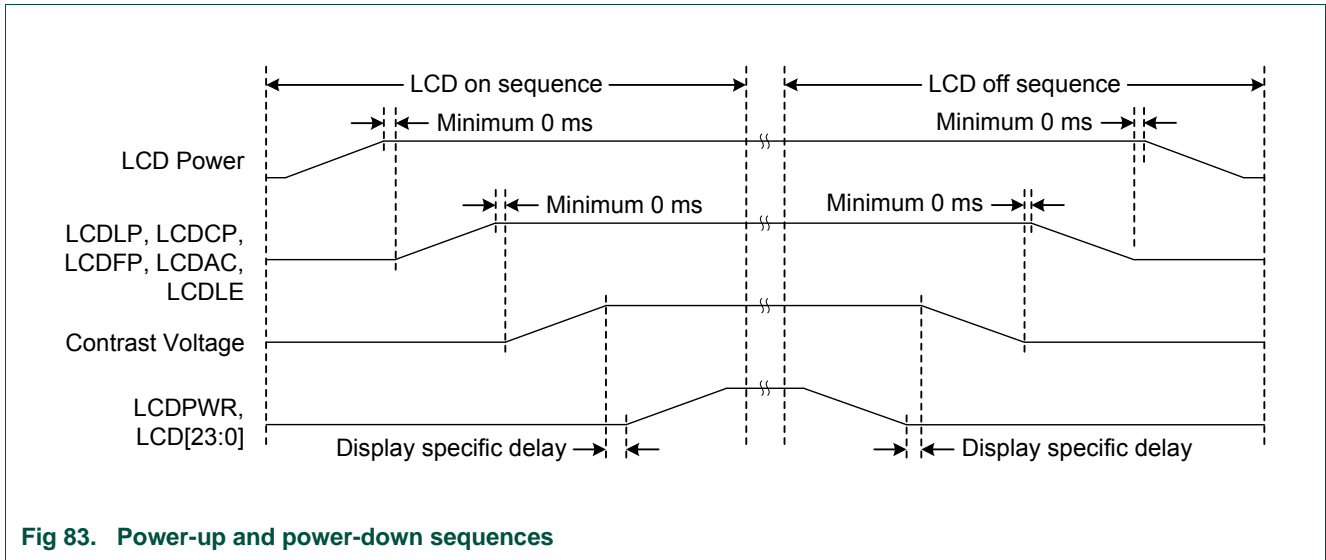

Fig 83. Power-up and power-down sequences

27.8 LCD timing diagrams

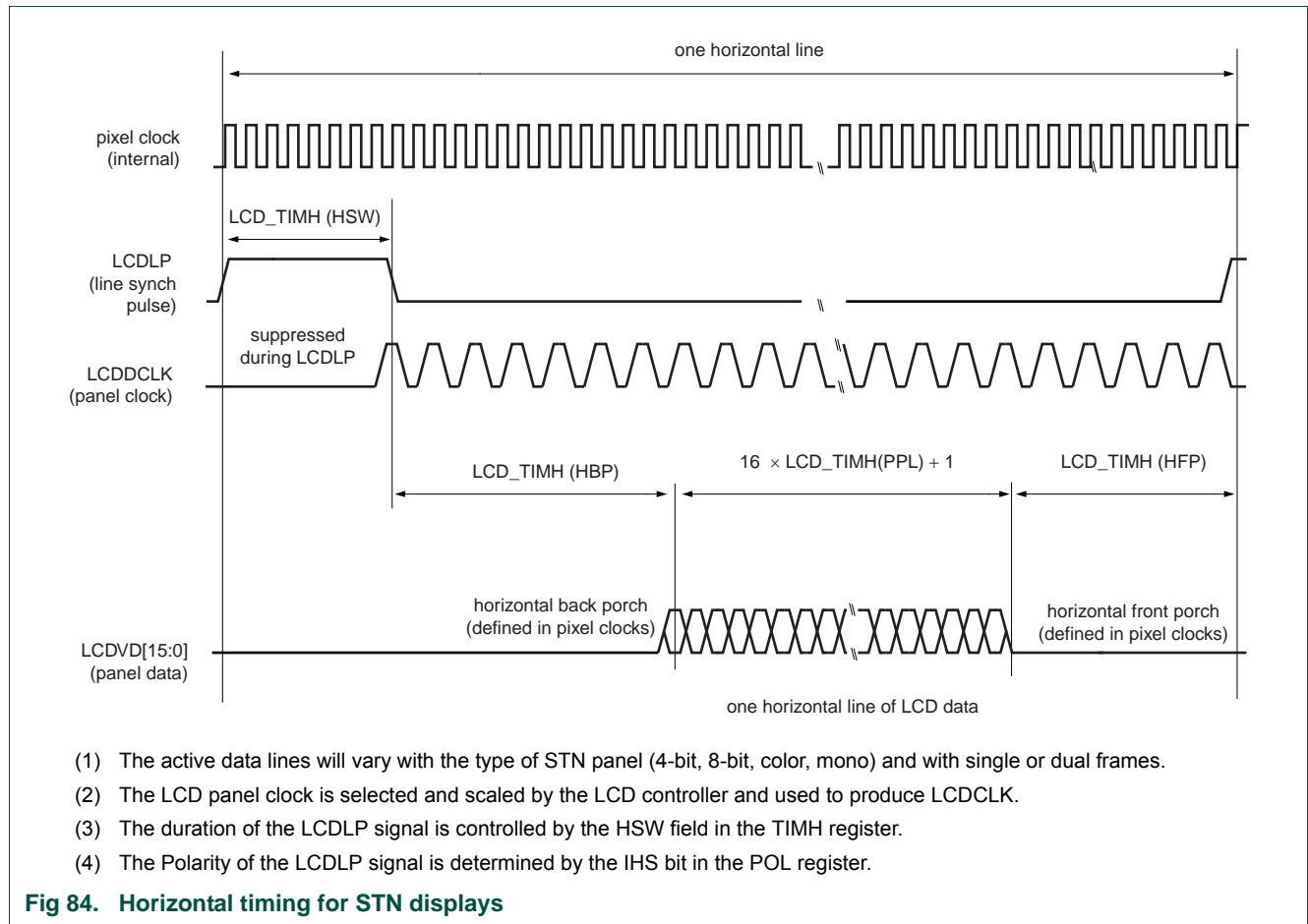
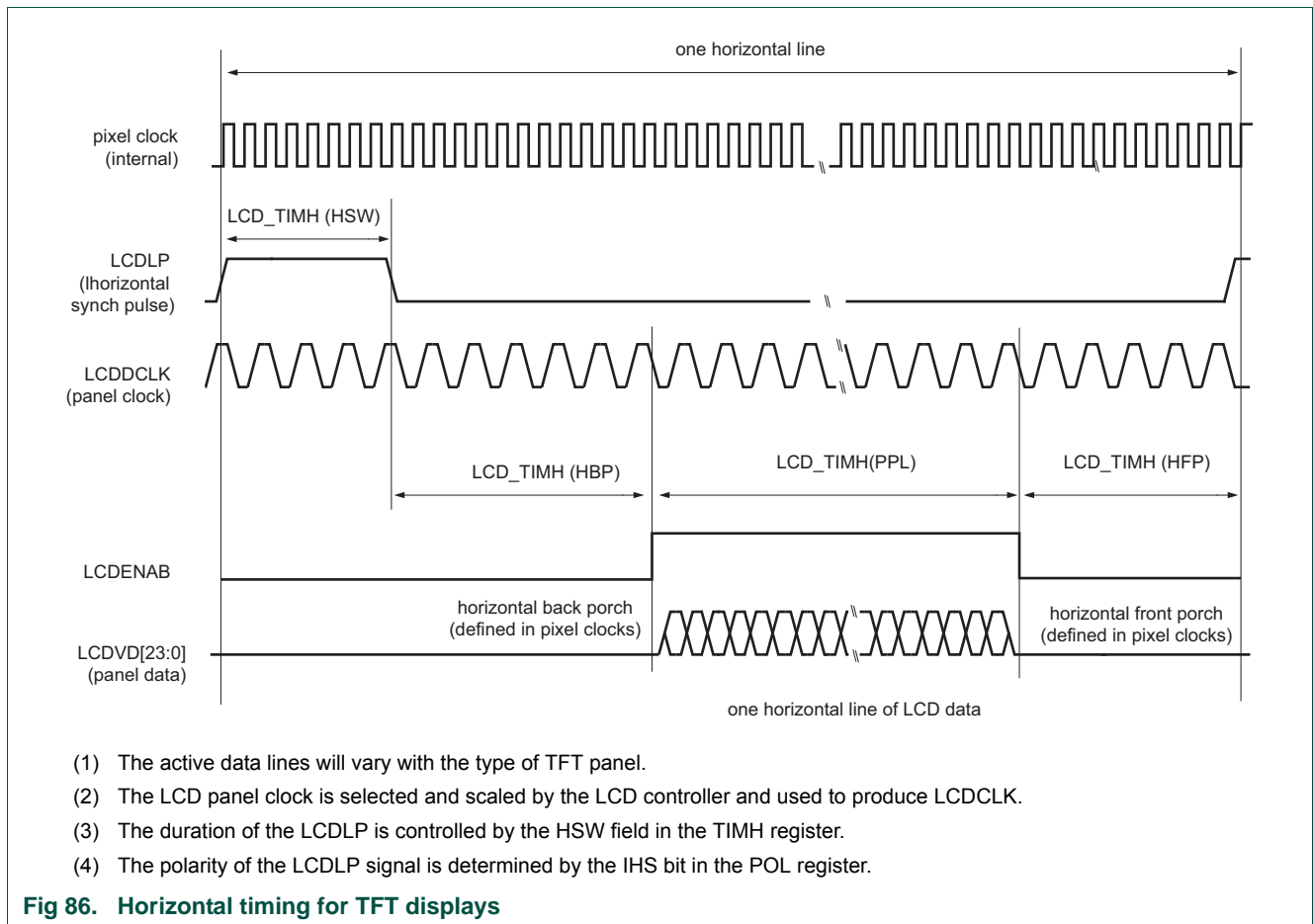
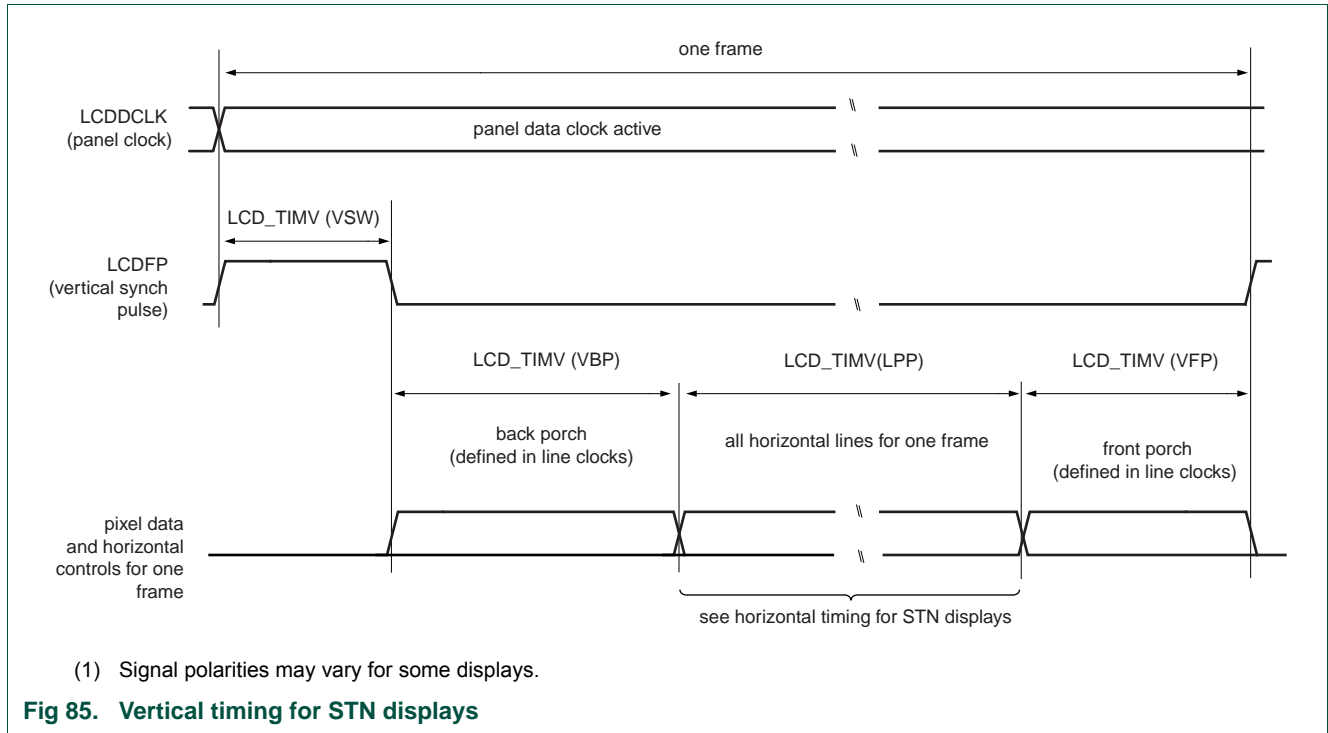
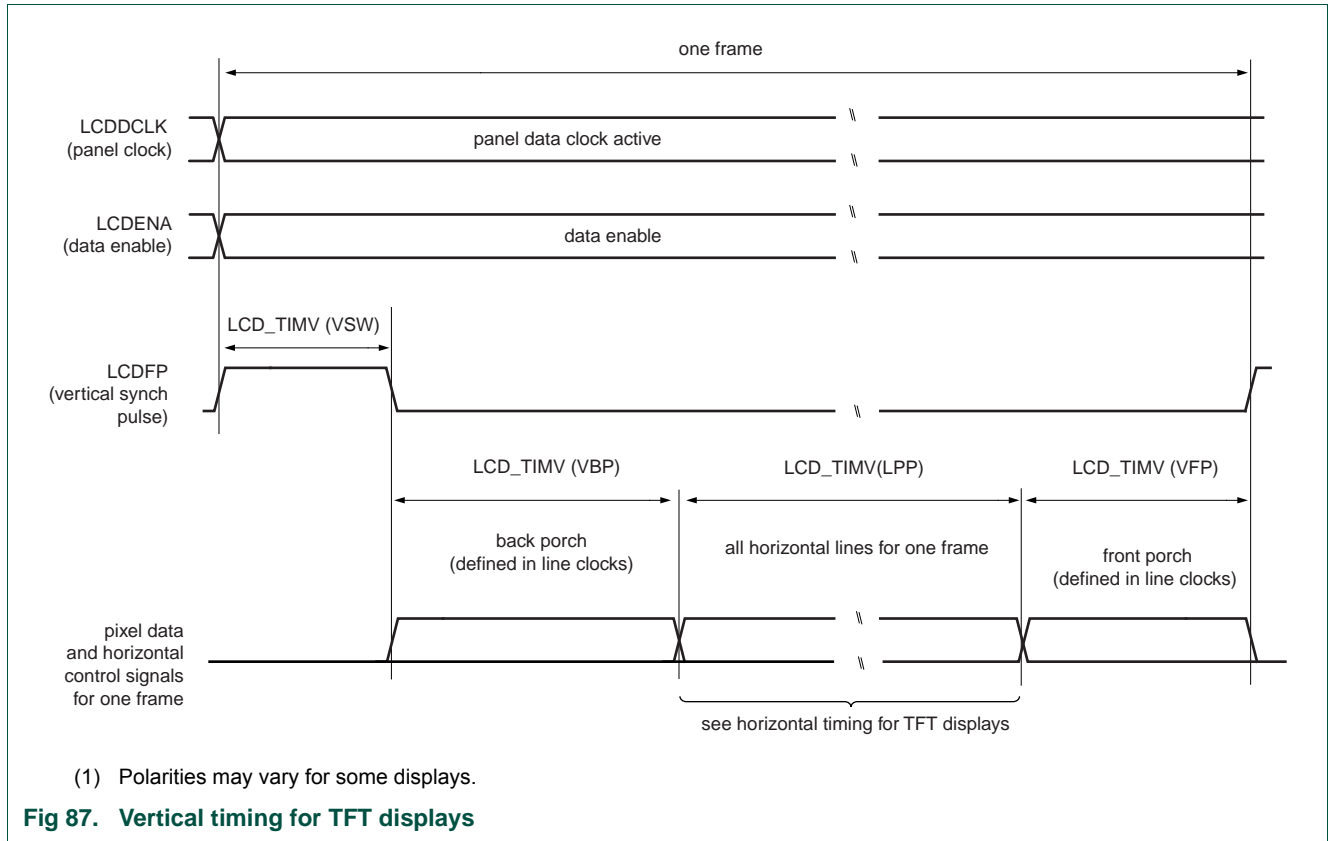

Fig 84. Horizontal timing for STN displays





27.9 LCD panel signal usage

Table 632. LCD panel connections for STN single panel mode

External pin	4-bit mono STN single panel		8-bit mono STN single panel		Color STN single panel	
	LPC18xx pin used	LCD function	LPC18xx pin used	LCD function	LPC18xx pin used	LCD function
LCDVD23	-	-	-	-	-	-
LCDVD22	-	-	-	-	-	-
LCDVD21	-	-	-	-	-	-
LCDVD20	-	-	-	-	-	-
LCDVD19	-	-	-	-	-	-
LCDVD18	-	-	-	-	-	-
LCDVD17	-	-	-	-	-	-
LCDVD16	-	-	-	-	-	-
LCDVD15	-	-	-	-	-	-
LCDVD14	-	-	-	-	-	-
LCDVD13	-	-	-	-	-	-
LCDVD12	-	-	-	-	-	-
LCDVD11	-	-	-	-	-	-
LCDVD10	-	-	-	-	-	-
LCDVD9	-	-	-	-	-	-

Table 632. LCD panel connections for STN single panel mode

External pin	4-bit mono STN single panel		8-bit mono STN single panel		Color STN single panel	
	LPC18xx pin used	LCD function	LPC18xx pin used	LCD function	LPC18xx pin used	LCD function
LCDVD8	-	-	-	-	-	-
LCDVD7	-	-	P8_4	UD[7]	P8_4	UD[7]
LCDVD6	-	-	P8_5	UD[6]	P8_5	UD[6]
LCDVD5	-	-	P8_6	UD[5]	P8_6	UD[5]
LCDVD4	-	-	P8_7	UD[4]	P8_7	UD[4]
LCDVD3	P4_2	UD[3]	P4_2	UD[3]	P4_2	UD[3]
LCDVD2	P4_3	UD[2]	P4_3	UD[2]	P4_3	UD[2]
LCDVD1	P4_4	UD[1]	P4_4	UD[1]	P4_4	UD[1]
LCDVD0	P4_1	UD[0]	P4_1	UD[0]	P4_1	UD[0]
LCDLP	P7_6	LCDLP	P7_6	LCDLP	P7_6	LCDLP
LCDENAB/ LCDM	P4_6	LCDENAB/ LCDM	P4_6	LCDENAB/ LCDM	P4_6	LCDENAB/ LCDM
LCDFP	P4_5	LCDFP	P4_5	LCDFP	P4_5	LCDFP
LCDDCLK	P4_7	LCDDCLK	P4_7	LCDDCLK	P4_7	LCDDCLK
LCDLE	P7_0	LCDLE	P7_0	LCDLE	P7_0	LCDLE
LCDPWR	P7_7	CDPWR	P7_7	LCDPWR	P7_7	LCDPWR
GP_CLKIN	PF_4	LCDCLKIN	PF_4	LCDCLKIN	PF_4	LCDCLKIN

Table 633. LCD panel connections for STN dual panel mode

External pin	4-bit mono STN dual panel		8-bit mono STN dual panel		Color STN dual panel	
	LPC18xx pin used	LCD function	LPC18xx pin used	LCD function	LPC18xx pin used	LCD function
LCDVD23	-	-	-	-	-	-
LCDVD22	-	-	-	-	-	-
LCDVD21	-	-	-	-	-	-
LCDVD20	-	-	-	-	-	-
LCDVD19	-	-	-	-	-	-
LCDVD18	-	-	-	-	-	-
LCDVD17	-	-	-	-	-	-
LCDVD16	-	-	-	-	-	-
LCDVD15	-	-	PB_4	LD[7]	PB_4	LD[7]
LCDVD14	-	-	PB_5	LD[6]	PB_5	LD[6]
LCDVD13	-	-	PB_6	LD[5]	PB_6	LD[5]
LCDVD12	-	-	P8_3	LD[4]	P8_3	LD[4]
LCDVD11	P4_9	LD[3]	P4_9	LD[3]	P4_9	LD[3]
LCDVD10	P4_10	LD[2]	P4_10	LD[2]	P4_10	LD[2]
LCDVD9	P4_8	LD[1]	P4_8	LD[1]	P4_8	LD[1]
LCDVD8	P7_5	LD[0]	P7_5	LD[0]	P7_5	LD[0]
LCDVD7	-	-	-	UD[7]	P8_4	UD[7]
LCDVD6	-	-	P8_5	UD[6]	P8_5	UD[6]

Table 633. LCD panel connections for STN dual panel mode

External pin	4-bit mono STN dual panel		8-bit mono STN dual panel		Color STN dual panel	
	LPC18xx pin used	LCD function	LPC18xx pin used	LCD function	LPC18xx pin used	LCD function
LCDVD5	-	-	P8_6	UD[5]	P8_6	UD[5]
LCDVD4	-	-	P8_7	UD[4]	P8_7	UD[4]
LCDVD3	P4_2	UD[3]	P4_2	UD[3]	P4_2	UD[3]
LCDVD2	P4_3	UD[2]	P4_3	UD[2]	P4_3	UD[2]
LCDVD1	P4_4	UD[1]	P4_4	UD[1]	P4_4	UD[1]
LCDVD0	P4_1	UD[0]	P4_1	UD[0]	P4_1	UD[0]
LCDLP	P7_6	LCDLP	P7_6	LCDLP	P7_6	LCDLP
LCDENAB/ LCDM	P4_6	LCDENAB/ LCDM	P4_6	LCDENAB/ LCDM	P4_6	LCDENAB/ LCDM
LCDFP	P4_5	LCDFP	P4_5	LCDFP	P4_5	LCDFP
LCDDCLK	P4_7	LCDDCLK	P4_7	LCDDCLK	P4_7	LCDDCLK
LCDLE	P7_0	LCDLE	P7_0	LCDLE	P7_0	LCDLE
LCDPWR	P7_7	LCDPWR	P7_7	LCDPWR	P7_7	LCDPWR
GP_CLKIN	PF_4	LCDCLKIN	PF_4	LCDCLKIN	PF_4	LCDCLKIN

Table 634. LCD panel connections for TFT panels

External pin	TFT 12 bit (4:4:4 mode)		TFT 16 bit (5:6:5 mode)		TFT 16 bit (1:5:5:5 mode)		TFT 24 bit	
	LPC18xx pin used	LCD function	LPC18xx pin used	LCD function	LPC18xx pin used	LCD function	LPC18xx pin used	LCD function
LCDVD23	PB_0	BLUE3	PB_0	BLUE4	PB_0	BLUE4	PB_0	BLUE7
LCDVD22	PB_1	BLUE2	PB_1	BLUE3	PB_1	BLUE3	PB_1	BLUE6
LCDVD21	PB_2	BLUE1	PB_2	BLUE2	PB_2	BLUE2	PB_2	BLUE5
LCDVD20	PB_3	BLUE0	PB_3	BLUE1	PB_3	BLUE1	PB_3	BLUE4
LCDVD19	-	-	P7_1	BLUE0	P7_1	BLUE0	P7_1	BLUE3
LCDVD18	-	-	-	-	P7_2	intensity	P7_2	BLUE2
LCDVD17	-	-	-	-	-	-	P7_3	BLUE1
LCDVD16	-	-	-	-	-	-	P7_4	BLUE0
LCDVD15	PB_4	GREEN3	PB_4	GREEN5	PB_4	GREEN4	PB_4	GREEN7
LCDVD14	PB_5	GREEN2	PB_5	GREEN4	PB_5	GREEN3	PB_5	GREEN6
LCDVD13	PB_6	GREEN1	PB_6	GREEN3	PB_6	GREEN2	PB_6	GREEN5
LCDVD12	P8_3	GREEN0	P8_3	GREEN2	P8_3	GREEN1	P8_3	GREEN4
LCDVD11	-	-	P4_9	GREEN1	P4_9	GREEN0	P4_9	GREEN3
LCDVD10	-	-	P4_10	GREEN0	P4_10	intensity	P4_10	GREEN2
LCDVD9	-	-	-	-	-	-	P4_8	GREEN1
LCDVD8	-	-	-	-	-	-	P7_5	GREEN0
LCDVD7	P8_4	RED3	P8_4	RED4	P8_4	RED4	P8_4	RED7
LCDVD6	P8_5	RED2	P8_5	RED3	P8_5	RED3	P8_5	RED6
LCDVD5	P8_6	RED1	P8_6	RED2	P8_6	RED2	P8_6	RED5
LCDVD4	P8_7	RED0	P8_7	RED1	P8_7	RED1	P8_7	RED4

Table 634. LCD panel connections for TFT panels

External pin	TFT 12 bit (4:4:4 mode)		TFT 16 bit (5:6:5 mode)		TFT 16 bit (1:5:5:5 mode)		TFT 24 bit	
	LPC18xx pin used	LCD function	LPC18xx pin used	LCD function	LPC18xx pin used	LCD function	LPC18xx pin used	LCD function
LCDVD3	-	-	P4_2	RED0	P4_2	RED0	P4_2	RED3
LCDVD2	-	-	-	-	P4_3	intensity	P4_3	RED2
LCDVD1	-	-	-	-	-	-	P4_4	RED1
LCDVD0	-	-	-	-	-	-	P4_1	RED0
LCDLP	P7_6	LCDLP	P7_6	LCDLP	P7_6	LCDLP	P7_6	LCDLP
LCDENAB/ LCDM	P4_6	LCDENAB/ LCDM	P4_6	LCDENAB/ LCDM	P4_6	LCDENAB/ LCDM	P4_6	LCDENAB/L CDM
LCDFP	P4_5	LCDFP	P4_5	LCDFP	P4_5	LCDFP	P4_5	LCDFP
LCDDCLK	P4_7	LCDDCLK	P4_7	LCDDCLK	P4_7	LCDDCLK	P4_7	LCDDCLK
LCDLE	P7_0	LCDLE	P7_0	LCDLE	P7_0	LCDLE	P7_0	LCDLE
LCDPWR	P7_7	LCDPWR	P7_7	LCDPWR	P7_7	LCDPWR	P7_7	LCDPWR
GP_CLKIN	PF_4	LCDCLKIN	PF_4	LCDCLKIN	PF_4	LCDCLKIN	PF_4	LCDCLKIN

28.1 How to read this chapter

The SCT without the dither engine is available on all flashless LPC18xx parts (LPC1850/30/20/10).

28.2 Basic configuration

The SCT is configured as follows:

- See [Table 635](#) for clocking and power control.
- The SCT is reset by the SCT_RST (reset #37).
- Connect inputs and outputs of the SCT through the GIMA (see [Chapter 17](#)).
- The SCT combined interrupt is connected to slot # 10 in the NVIC. SCT outputs 2, 6, 14 are ORed with timer match channels and connected to slots # 13, 14, 16 in the Event router (see [Table 74](#)).
- To connect the SCT outputs 0 and 1 to the GPDMA, use the DMAMUX register in the CREG block (see [Table 92](#)).
- The SCT outputs are ORed with various timer match outputs (see [Table 636](#)) if bit CTOUTCTRL in CREG6 is zero (see [Table 96](#); this is the default). Set the CTOUTCTRL bit to one to use the SCT outputs without interference from the timers.

Table 635. SCT clocking and power control

	Base clock	Branch clock	Operating frequency
SCT	BASE_M3_CLK	CLK_M3_SCT	up to 180 MHz

28.3 Features

- Two 16-bit counters or one 32-bit counter.
- Counters clocked by bus clock or selected input.
- Up counters or up-down counters.
- State variable allows sequencing across multiple counter cycles.
- The following conditions define an event: a counter match condition, an input (or output) condition, a combination of a match and/or and input/output condition in a specified state.
- Events control outputs, interrupts, and DMA requests.
- Selected events can limit, halt, start, or stop a counter.
- Supports:
 - 8 inputs
 - 16 outputs
 - 16 match/capture registers

- 16 events
- 32 states

28.4 General description

The State Configurable Timer (SCT) allows a wide variety of timing, counting, output modulation, and input capture operations.

The most basic user-programmable option is whether a SCT operates as two 16-bit counters or a unified 32-bit counter. In the two-counter case, in addition to the counter value the following operational elements are independent for each half:

- State variable
- Limit, halt, stop, and start conditions
- Values of Match/Capture registers, plus reload or capture control values

In the two-counter case, the following operational elements are global to the SCT:

- Clock selection
- Inputs
- Events
- Outputs
- Interrupts
- DMA requests

Events, outputs, interrupts, and DMA requests can use match conditions from either counter.

Remark: This document uses the term “bus error” to indicate an SCT response that makes the processor take an exception.

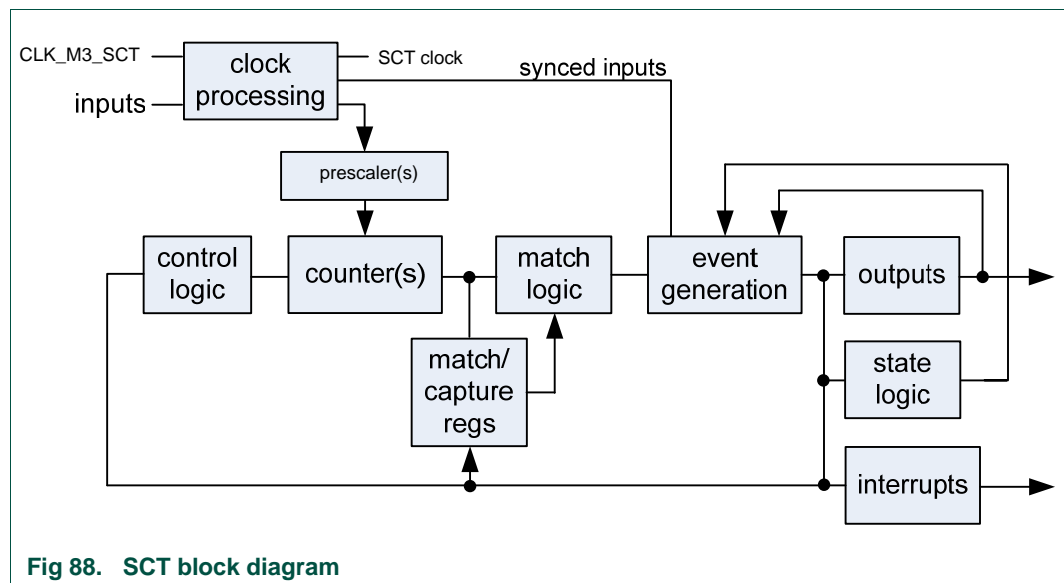

Fig 88. SCT block diagram

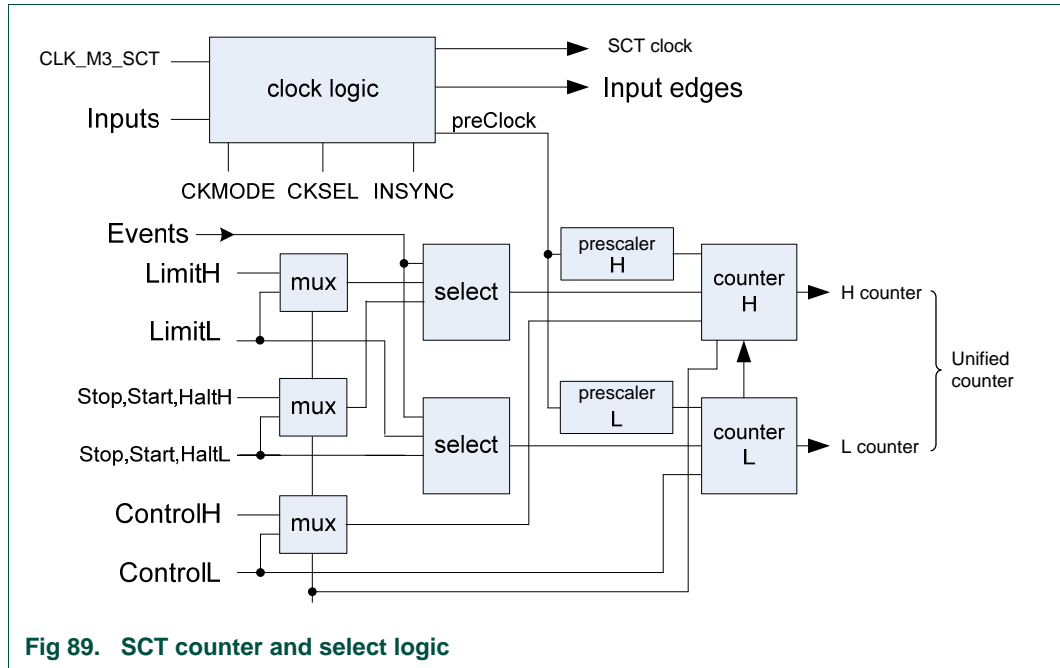

Fig 89. SCT counter and select logic

28.5 Pin description

The SCT inputs can originate from the external pins or from several internal sources. Each SCT input is connected to one GIMA register which defines the input source.

Remark: SCT outputs are connected to the CTOUT_n pins and are ORed with timer match outputs when the CTOCTRL bit is set to 0 in CREG6 (see [Table 96](#); this is the default). Some SCT outputs are connected to multiple destinations at once, for example to an external pin and the event router.

Table 636. SCT inputs and outputs

Description	Pin function	Internal signal	Default (see GIMA, Table 190)	CTOUTCTRL bit (see Table 96)
SCT inputs				
SCT input 0	CTIN_0	-	yes	-
SCT input 1	CTIN_1	-	yes	-
	-	USART2 TX active	no	-
	-	USART0 TX active	no	-
SCT input 2	CTIN_2	-	yes	-
SCT input 3	CTIN_3	-	yes	-
	-	I2S1_RX_MWS	no	-
	-	I2S1_TX_MWS	no	-
	-	I2S1_TX_MWS	no	-
SCT input 4	CTIN4	-	yes	-
	-	USART0 RX active	no	-
	-	I2S1_RX_MWS	no	-
	-	I2S1_TX_MWS	no	-
	-	I2S1_TX_MWS	no	-

Table 636. SCT inputs and outputs ...continued

Description	Pinfunction	Internal signal	Default (see GIMA, Table 190)	CTOUTCTRL bit (see Table 96)
SCT input 5	CTIN_5	-	yes	-
	-	USART2 TX active	no	-
SCT input 6	CTIN_6	-	yes	-
	-	USART3 TX active	no	-
	-	I2S0_RX_MWS	no	-
	-	I2S0_TX_MWS	no	-
SCT input 7	CTIN_7	-	yes	-
	-	USART3 RX active	no	-
	-	SOF0	no	-
	-	SOF1	no	-
SCT outputs				
SCT output 0 ORed with Timer0 match output 0	CTOUT_0	-	-	0
SCT output 0	CTOUT_0	-	-	1
SCT output 1 ORed with Timer3 match output 3	CTOUT_1	-	-	0
SCT output 1	CTOUT_1	-	-	1
SCT output 2 ORed with Timer0 match output 2	CTOUT_2	Event router input 13	-	0
SCT output 2	CTOUT_2	Event router input 13	-	1
SCT output 3 ORed with Timer0 match output 3	CTOUT_3	T1 capture channel 3	-	0
SCT output 3	CTOUT_3	T1 capture channel 3	-	1
SCT output 4 ORed with Timer3 match output 3	CTOUT_4	-	-	0
SCT output 4	CTOUT_4	-	-	1
SCT output 5 ORed with Timer3 match output 3	CTOUT_5	-	-	0
SCT output 5	CTOUT_5	-	-	1
SCT output 6 ORed with Timer1 match output 2	CTOUT_6	Event router input 14	-	0
SCT output 6	CTOUT_6	Event router input 14	-	1
SCT output 7 ORed with Timer1 match output 3	CTOUT_7	T2 capture channel 3	-	0
SCT output 7	CTOUT_7	T2 capture channel 3	-	1
SCT output 8 ORed with Timer2 match output 0	CTOUT_8	ADC start1 input (ADC CR register bit START = 0x3)	-	0
SCT output 8	CTOUT_8	ADC start1 input (ADC CR register bit START = 0x3)	-	1
SCT output 9 ORed with Timer3 match output 3	CTOUT_9	-	-	0
SCT output 9	CTOUT_9	-	-	1
SCT output 10 ORed with Timer3 match output 3	CTOUT_10	-	-	0
SCT output 10	CTOUT_10	-	-	1
SCT output 11 ORed with Timer2 match output 3	CTOUT_11	T3 capture channel 3	-	0
SCT output 11	CTOUT_11	T3 capture channel 3	-	1
SCT output 12 ORed with Timer3 match output 3	CTOUT_12	-	-	0

Table 636. SCT inputs and outputs ...continued

Description	Pinfunction	Internal signal	Default (see GIMA, Table 190)	CTOUTCTRL bit (see Table 96)
SCT output 12	CTOUT_12	-	-	1
SCT output 13 ORed with Timer3 match output 3	CTOUT_13	-	-	0
SCT output 13	CTOUT_13	-	-	1
SCT output 14 ORed with Timer3 match output 2	CTOUT_14	Event router input 16	-	0
SCT output 14	CTOUT_14	Event router input 16	-	1
SCT output 15 ORed with Timer3 match output 3	CTOUT_15	T0 capture channel 3/ADC start0 input (ADC CR register START bits = 0x2)	-	0
SCT output 15	CTOUT_15	T0 capture channel 3/ADC start0 input (ADC CR register START bits = 0x2)	-	1

28.6 Register description

The register addresses of the State Configurable Timer are shown in [Table 637](#). For most of the SCT registers, the register function depends on the setting of certain other register bits:

- The UNIFY bit in the CONFIG register determines whether the SCT is used as one 32-bit register (for operation as one 32-bit counter/timer) or as two 16-bit counter/timers named L and H. The setting of the UNIFY bit is reflected in the register map:
 - UNIFY = 1: Only one register is used (for operation as one 32-bit counter/timer).
 - UNIFY = 0: Access the L and H registers by a 32-bit read or write operation or can be read or written to individually (for operation as two 16-bit counter/timers).

Typically, the UNIFY bit is configured by writing to the CONFIG register before any other registers are accessed.
- The REGMODEn bits in the REGMODE register determine whether each set of Match/Capture registers uses the match or capture functionality:
 - REGMODEn = 0: Registers operate as match and reload registers.
 - REGMODEn = 1: Registers operate as capture and capture control registers.

Table 637. Register overview: State Configurable Timer (base address 0x4000 0000)

Name	Access	Address offset	Description	Reset value	Reference
CONFIG	R/W	0x000	SCT configuration register	0x0000 7E00	Table 638
CTRL	R/W	0x004	SCT control register	0x0004 0004	Table 639
CTRL_L	R/W	0x004	SCT control register low counter 16-bit	0x0004 0004	Table 639
CTRL_H	R/W	0x006	SCT control register high counter 16-bit	0x0004 0004	Table 639
LIMIT	R/W	0x008	SCT limit register	0x0000 0000	Table 640
LIMIT_L	R/W	0x008	SCT limit register low counter 16-bit	0x0000 0000	Table 640

Table 637. Register overview: State Configurable Timer (base address 0x4000 0000) ...continued

Name	Access	Address offset	Description	Reset value	Reference
LIMIT_H	R/W	0x00A	SCT limit register high counter 16-bit	0x0000 0000	Table 640
HALT	R/W	0x00C	SCT halt condition register	0x0000 0000	Table 641
HALT_L	R/W	0x00C	SCT halt condition register low counter 16-bit	0x0000 0000	Table 641
HALT_H	R/W	0x00E	SCT halt condition register high counter 16-bit	0x0000 0000	Table 641
STOP	R/W	0x010	SCT stop condition register	0x0000 0000	Table 642
STOP_L	R/W	0x010	SCT stop condition register low counter 16-bit	0x0000 0000	Table 642
STOP_H	R/W	0x012	SCT stop condition register high counter 16-bit	0x0000 0000	Table 642
START	R/W	0x014	SCT start condition register	0x0000 0000	Table 643
START_L	R/W	0x014	SCT start condition register low counter 16-bit	0x0000 0000	Table 643
START_H	R/W	0x016	SCT start condition register high counter 16-bit	0x0000 0000	Table 643
-	-	0x018 - 0x03C	Reserved	-	-
COUNT	R/W	0x040	SCT counter register	0x0000 0000	Table 644
COUNT_L	R/W	0x040	SCT counter register low counter 16-bit	0x0000 0000	Table 644
COUNT_H	R/W	0x042	SCT counter register high counter 16-bit	0x0000 0000	Table 644
STATE	R/W	0x044	SCT state register	0x0000 0000	Table 645
STATE_L	R/W	0x044	SCT state register low counter 16-bit	0x0000 0000	Table 645
STATE_H	R/W	0x046	SCT state register high counter 16-bit	0x0000 0000	Table 645
INPUT	RO	0x048	SCT input register	0x0000 0000	Table 646
REGMODE	R/W	0x04C	SCT match/capture registers mode register	0x0000 0000	Table 647
REGMODE_L	R/W	0x04C	SCT match/capture registers mode register low counter 16-bit	0x0000 0000	Table 647
REGMODE_H	R/W	0x04E	SCT match/capture registers mode register high counter 16-bit	0x0000 0000	Table 647
OUTPUT	R/W	0x050	SCT output register	0x0000 0000	Table 648
OUTPUTDIRCTRL	R/W	0x054	SCT output counter direction control register	0x0000 0000	Table 649
RES	R/W	0x058	SCT conflict resolution register	0x0000 0000	Table 650
DMAREQ0	R/W	0x05C	SCT DMA request 0 register	0x0000 0000	Table 651
DMAREQ1	R/W	0x060	SCT DMA request 1 register	0x0000 0000	Table 652
-	-	0x064 - 0x0EC	Reserved	-	-
EVEN	R/W	0x0F0	SCT event enable register	0x0000 0000	Table 653
EVFLAG	R/W	0x0F4	SCT event flag register	0x0000 0000	Table 654
CONEN	R/W	0x0F8	SCT conflict enable register	0x0000 0000	Table 655
CONFLAG	R/W	0x0FC	SCT conflict flag register	0x0000 0000	Table 656
MATCH0 to MATCH15	R/W	0x100 to 0x13C	SCT match value register of match channels 0 to 15; REGMOD0 to REGMODE15 = 0	0x0000 0000	Table 656
MATCH0_L to MATCH15_L	R/W	0x100 to 0x13C	SCT match value register of match channels 0 to 15; low counter 16-bit; REGMOD0_L to REGMODE15_L = 0	0x0000 0000	Table 656

Table 637. Register overview: State Configurable Timer (base address 0x4000 0000) ...continued

Name	Access	Address offset	Description	Reset value	Reference
MATCH0_H to MATCH15_H	R/W	0x102 to 0x13E	SCT match value register of match channels 0 to 15; high counter 16-bit; REGMOD0_H to REGMODE15_H = 0	0x0000 0000	Table 656
CAP0 to CAP15		0x100 to 0x13C	SCT capture register of capture channel 0 to 15; REGMOD0 to REGMODE15 = 1	0x0000 0000	Table 658
CAP0_L to CAP15_L		0x100 to 0x13C	SCT capture register of capture channel 0 to 15; low counter 16-bit; REGMOD0_L to REGMODE15_L = 1	0x0000 0000	Table 658
CAP0_H to CAP15_H		0x102 to 0x13E	SCT capture register of capture channel 0 to 15; high counter 16-bit; REGMOD0_H to REGMODE15_H = 1	0x0000 0000	Table 658
MATCH0_L to MATCH15_L	R/W	0x180 to 0x1A0	MATCH alias register (see Section 28.7.9). SCT match value register of match channels 0 to 15; low counter 16-bit; REGMOD0_L to REGMODE15_L = 0	0x0000 0000	Table 656
MATCH0_H to MATCH15_H	R/W	0x1C0 to 0x1E0	MATCH alias register (see Section 28.7.9). SCT match value register of match channels 0 to 15; high counter 16-bit; REGMOD0_H to REGMODE15_H = 0	0x0000 0000	Table 656
CAP0_L to CAP15_L		0x180 to 0x1A0	CAP alias register (see Section 28.7.9). SCT capture register of capture channel 0 to 15; low counter 16-bit; REGMOD0_L to REGMODE15_L = 1	0x0000 0000	Table 658
CAP0_H to CAP15_H		0x1C0 to 0x1E0	CAP alias register (see Section 28.7.9). SCT capture register of capture channel 0 to 15; high counter 16-bit; REGMOD0_H to REGMODE15_H = 1	0x0000 0000	Table 658
MATCHREL0 to MATCHREL15	R/W	0x200 to 0x23C	SCT match reload value register 0 to 15; REGMOD0 = 0 to REGMODE15 = 0	0x0000 0000	Table 659
MATCHREL0_L to MATCHREL15_L	R/W	0x200 to 0x23C	SCT match reload value register 0 to 15; low counter 16-bit; REGMOD0_L = 0 to REGMODE15_L = 0	0x0000 0000	Table 659
MATCHREL0_H to MATCHREL15_H	R/W	0x202 to 0x23E	SCT match reload value register 0 to 15; high counter 16-bit; REGMOD0_H = 0 to REGMODE15_H = 0	0x0000 0000	Table 659
CAPCTRL0 to CAPCTRL15		0x200 to 0x23C	SCT capture control register 0 to 15; REGMOD0 = 1 to REGMODE15 = 1	0x0000 0000	Table 660
CAPCTRL0_L to CAPCTRL15_L		0x200 to 0x23C	SCT capture control register 0 to 15; low counter 16-bit; REGMOD0_L = 1 to REGMODE15_L = 1	0x0000 0000	Table 660
CAPCTRL0_H to CAPCTRL15_H		0x202 to 0x23E	SCT capture control register 0 to 15; high counter 16-bit; REGMOD0 = 1 to REGMODE15 = 1	0x0000 0000	Table 660
MATCHREL0_L to MATCHREL15_L	R/W	0x280 to 0x2A0	MATCHREL alias registers (see Section 28.7.9). SCT match reload value register 0 to 15; low counter 16-bit; REGMOD0_L = 0 to REGMODE15_L = 0	0x0000 0000	Table 659
MATCHREL0_H to MATCHREL15_H	R/W	0x2C0 to 0x2E0	MATCHREL alias registers (see Section 28.7.9). SCT match reload value register 0 to 15; high counter 16-bit; REGMOD0_H = 0 to REGMODE15_H = 0	0x0000 0000	Table 659

Table 637. Register overview: State Configurable Timer (base address 0x4000 0000) ...continued

Name	Access	Address offset	Description	Reset value	Reference
CAPCTRL0_L to CAPCTRL15_L		0x280 to 0x2A0	CAPCTRL alias registers (see Section 28.7.9). SCT capture control register 0 to 15; low counter 16-bit; REGMOD0_L = 1 to REGMODE15_L = 1	0x0000 0000	Table 660
CAPCTRL0_H to CAPCTRL15_H		0x2C0 to 0x2E0	CAPCTRL alias registers (see Section 28.7.9). SCT capture control register 0 to 15; high counter 16-bit; REGMOD0 = 1 to REGMODE15 = 1	0x0000 0000	Table 660
EVSTATEMSK0	R/W	0x300	SCT event state register 0	0x0000 0000	Table 661
EVCTRL0	R/W	0x304	SCT event control register 0	0x0000 0000	Table 662
EVSTATEMSK1	R/W	0x308	SCT event state register 1	0x0000 0000	Table 661
EVCTRL1	R/W	0x30C	SCT event control register 1	0x0000 0000	Table 662
EVSTATEMSK2	R/W	0x310	SCT event state register 2	0x0000 0000	Table 661
EVCTRL2	R/W	0x314	SCT event control register 2	0x0000 0000	Table 662
EVSTATEMSK3	R/W	0x318	SCT event state register 3	0x0000 0000	Table 661
EVCTRL3	R/W	0x31C	SCT event control register 3	0x0000 0000	Table 662
EVSTATEMSK4	R/W	0x320	SCT event state register 4	0x0000 0000	Table 661
EVCTRL4	R/W	0x324	SCT event control register4	0x0000 0000	Table 662
EVSTATEMSK5	R/W	0x328	SCT event state register 5	0x0000 0000	Table 661
EVCTRL5	R/W	0x32C	SCT event control register 5	0x0000 0000	Table 662
EVSTATEMSK6	R/W	0x330	SCT event state register 6	0x0000 0000	Table 661
EVCTRL6	R/W	0x334	SCT event control register 6	0x0000 0000	Table 662
EVSTATEMSK7	R/W	0x338	SCT event state register 7	0x0000 0000	Table 661
EVCTRL7	R/W	0x33C	SCT event control register 7	0x0000 0000	Table 662
EVSTATEMSK8	R/W	0x340	SCT event state register 8	0x0000 0000	Table 661
EVCTRL8	R/W	0x344	SCT event control register 8	0x0000 0000	Table 662
EVSTATEMSK9	R/W	0x348	SCT event state register 9	0x0000 0000	Table 661
EVCTRL9	R/W	0x34C	SCT event control register 9	0x0000 0000	Table 662
EVSTATEMSK10	R/W	0x350	SCT event state register 10	0x0000 0000	Table 661
EVCTRL10	R/W	0x354	SCT event control register 10	0x0000 0000	Table 662
EVSTATEMSK11	R/W	0x358	SCT event state register 11	0x0000 0000	Table 661
EVCTRL11	R/W	0x35C	SCT event control register 11	0x0000 0000	Table 662
EVSTATEMSK12	R/W	0x360	SCT event state register 12	0x0000 0000	Table 661
EVCTRL12	R/W	0x364	SCT event control register 12	0x0000 0000	Table 662
EVSTATEMSK13	R/W	0x368	SCT event state register 13	0x0000 0000	Table 661
EVCTRL13	R/W	0x36C	SCT event control register 13	0x0000 0000	Table 662
EVSTATEMSK14	R/W	0x370	SCT event state register 14	0x0000 0000	Table 661
EVCTRL14	R/W	0x374	SCT event control register 14	0x0000 0000	Table 662
EVSTATEMSK15	R/W	0x378	SCT event state register 15	0x0000 0000	Table 661
EVCTRL15	R/W	0x37C	SCT event control register 15	0x0000 0000	Table 662
OUTPUTSET0	R/W	0x500	SCT output 0 set register	0x0000 0000	Table 663
OUTPUTCL0	R/W	0x504	SCT output 0 clear register	0x0000 0000	Table 664
OUTPUTSET1	R/W	0x508	SCT output 1 set register	0x0000 0000	Table 663

Table 637. Register overview: State Configurable Timer (base address 0x4000 0000) ...continued

Name	Access	Address offset	Description	Reset value	Reference
OUTPUTCL1	R/W	0x50C	SCT output 1 clear register	0x0000 0000	Table 664
OUTPUTSET2	R/W	0x510	SCT output 2 set register	0x0000 0000	Table 663
OUTPUTCL2	R/W	0x514	SCT output 2 clear register	0x0000 0000	Table 664
OUTPUTSET3	R/W	0x518	SCT output 3 set register	0x0000 0000	Table 663
OUTPUTCL3	R/W	0x51C	SCT output 3 clear register	0x0000 0000	Table 664
OUTPUTSET4	R/W	0x520	SCT output 4 set register	0x0000 0000	Table 663
OUTPUTCL4	R/W	0x524	SCT output 4 clear register	0x0000 0000	Table 664
OUTPUTSET5	R/W	0x528	SCT output 5 set register	0x0000 0000	Table 663
OUTPUTCL5	R/W	0x52C	SCT output 5 clear register	0x0000 0000	Table 664
OUTPUTSET6	R/W	0x530	SCT output 6 set register	0x0000 0000	Table 663
OUTPUTCL6	R/W	0x534	SCT output 6 clear register	0x0000 0000	Table 664
OUTPUTSET7	R/W	0x538	SCT output 7 set register	0x0000 0000	Table 663
OUTPUTCL7	R/W	0x53C	SCT output 7 clear register	0x0000 0000	Table 664
OUTPUTSET8	R/W	0x540	SCT output 8 set register	0x0000 0000	Table 663
OUTPUTCL8	R/W	0x544	SCT output 8 clear register	0x0000 0000	Table 664
OUTPUTSET9	R/W	0x548	SCT output 9 set register	0x0000 0000	Table 663
OUTPUTCL9	R/W	0x54C	SCT output 9 clear register	0x0000 0000	Table 664
OUTPUTSET10	R/W	0x550	SCT output 10 set register	0x0000 0000	Table 663
OUTPUTCL10	R/W	0x554	SCT output 10 clear register	0x0000 0000	Table 664
OUTPUTSET11	R/W	0x558	SCT output 11 set register	0x0000 0000	Table 663
OUTPUTCL11	R/W	0x55C	SCT output 11 clear register	0x0000 0000	Table 664
OUTPUTSET12	R/W	0x560	SCT output 12 set register	0x0000 0000	Table 663
OUTPUTCL12	R/W	0x564	SCT output 12 clear register	0x0000 0000	Table 664
OUTPUTSET13	R/W	0x568	SCT output 13 set register	0x0000 0000	Table 663
OUTPUTCL13	R/W	0x56C	SCT output 13 clear register	0x0000 0000	Table 664
OUTPUTSET14	R/W	0x570	SCT output 14 set register	0x0000 0000	Table 663
OUTPUTCL14	R/W	0x574	SCT output 14 clear register	0x0000 0000	Table 664
OUTPUTSET15	R/W	0x578	SCT output 15 set register	0x0000 0000	Table 663
OUTPUTCL15	R/W	0x57C	SCT output 15 clear register	0x0000 0000	Table 664

28.6.1 SCT configuration register

This register configures the overall operation of the SCT. Write to this register before any other registers.

Table 638. SCT configuration register (CONFIG - address 0x4000 0000) bit description

Bit	Symbol	Value	Description	Reset value
0	UNIFY		SCT operation	0
		0	The SCT operates as two 16-bit counters named L and H.	
		1	The SCT operates as a unified 32-bit counter.	

Table 638. SCT configuration register (CONFIG - address 0x4000 0000) bit description ...continued

Bit	Symbol	Value	Description	Reset value
2:1	CLKMODE		SCT clock mode	00
		0x0	The bus clock clocks the SCT and prescalers.	
		0x1	The SCT clock is the bus clock, but the prescalers are enabled to count only when sampling of the input selected by the CKSEL field finds the selected edge. The minimum pulse width on the clock input is 1 bus clock period. This mode is the high-performance sampled-clock mode.	
		0x2	The input selected by CKSEL clocks the SCT and prescalers. The input is synchronized to the bus clock and possibly inverted. The minimum pulse width on the clock input is 1 bus clock period. This mode is the low-power sampled-clock mode.	
		0x3	Reserved.	
6:3	CKSEL		SCT clock select	0000
		0x0	Rising edges on input 0.	
		0x1	Falling edges on input 0.	
		0x2	Rising edges on input 1.	
		0x3	Falling edges on input 1.	
		0x4	Rising edges on input 2.	
		0x5	Falling edges on input 2.	
		0x6	Rising edges on input 3.	
		0x7	Falling edges on input 3.	
		0x8	Rising edges on input 4.	
		0x9	Falling edges on input 4.	
		0xA	Rising edges on input 5.	
		0xB	Falling edges on input 5.	
		0xC	Rising edges on input 6.	
		0xD	Falling edges on input 6.	
0xE	Rising edges on input 7.			
0xF	Falling edges on input 7.			
7	NORELAOD_L	-	A 1 in this bit prevents the lower match registers from being reloaded from their respective reload registers. Software can write to set or clear this bit at any time. This bit applies to both the higher and lower registers when the UNIFY bit is set.	0
8	NORELOADH	-	A 1 in this bit prevents the higher match registers from being reloaded from their respective reload registers. Software can write to set or clear this bit at any time. This bit is not used when the UNIFY bit is set.	0
16:9	INSYNcN	-	Synchronization for input n (bit 9 = input 0, bit 10 = input 1,..., bit 16 = input 7). A 1 in one of these bits subjects the corresponding input to synchronization to the SCT clock, before it is used to create an event. If an input is synchronous to the SCT clock, keep its bit 0 for faster response. When the CKMODE field is 1x, the bit in this field, corresponding to the input selected by the CKSEL field, is not used.	1
31:17	-		Reserved	-

28.6.2 SCT control register

If UNIFY = 1 in the CONFIG register, only the _L bits are used.

If UNIFY = 0 in the CONFIG register, this register can be written to as two registers CTRL_L and CTRL_H. Both the L and H registers can be read or written individually or in a single 32-bit read or write operation.

All bits in this register can be written to when the counter is stopped or halted. When the counter is running, the only bits that can be written are STOP or HALT. (Other bits can be written in a subsequent write after HALT is set to 1.)

Table 639. SCT control register (CTRL - address 0x4000 0004) bit description

Bit	Symbol	Value	Description	Reset value
0	DOWN_L	-	This bit is 1 when the L or unified counter is counting down. Hardware sets this bit when the counter limit is reached and BIDIR is 1. Hardware clears this bit when the counter reaches 0.	0
1	STOP_L	-	When this bit is 1 and HALT is 0, the L or unified counter does not run but I/O events related to the counter can occur. If such an event matches the mask in the Start register, this bit is cleared and counting resumes.	0
2	HALT_L	-	When this bit is 1, the L or unified counter does not run and no events can occur. A reset sets this bit. When the HALT_L bit is one, the STOP_L bit is cleared. If you want to remove the halt condition and keep the SCT in the stop condition (not running), then you can change the halt and stop condition with one single write to this register. Remark: Once set, only software can clear this bit to restore counter operation.	1
3	CLRCTR_L	-	Writing a 1 to this bit clears the L or unified counter. This bit always reads as 0.	0
4	BIDIR_L	-	L or unified counter direction select	0
		0	The counter counts up to its limit condition, then is cleared to zero.	
		1	The counter counts up to its limit, then counts down to 0.	
12:5	PRE_L	-	Specifies the factor by which the SCT clock is prescaled to produce the L or unified counter clock. The counter clock is clocked at the rate of the SCT clock divided by PRE_L+1. Remark: Clear the counter (by writing a 1 to the CLRCTR bit) whenever changing the PRE value.	0
15:13	-	-	Reserved	
16	DOWN_H	-	This bit is 1 when the H counter is counting down. Hardware sets this bit when the counter limit is reached and BIDIR is 1. Hardware clears this bit when the counter reaches 0.	0
17	STOP_H	-	When this bit is 1 and HALT is 0, the H counter does not run but I/O events related to the counter can occur. If such an event matches the mask in the Start register, this bit is cleared and counting resumes.	0
18	HALT_H	-	When this bit is 1, the H counter does not run and no events can occur. A reset sets this bit. When the HALT_H bit is one, the STOP_H bit is cleared. If you want to remove the halt condition and keep the SCT in the stop condition (not running), then you can change the halt and stop condition with one single write to this register. Remark: Once set, this bit can only be cleared by software to restore counter operation.	1
19	CLRCTR_H	-	Writing a 1 to this bit clears the H counter. This bit always reads as 0.	0

Table 639. SCT control register (CTRL - address 0x4000 0004) bit description

Bit	Symbol	Value	Description	Reset value
20	BIDIR_H		Direction select	0
		0	The H counter counts up to its limit condition, then is cleared to zero.	
		1	The H counter counts up to its limit, then counts down to 0.	
28:21	PRE_H	-	Specifies the factor by which the SCT clock is prescaled to produce the H counter clock. The counter clock is clocked at the rate of the SCT clock divided by PRELH+1. Remark: Clear the counter (by writing a 1 to the CLRCTR bit) whenever changing the PRE value.	0
31:29	-		Reserved	

28.6.3 SCT limit register

If UNIFY = 1 in the CONFIG register, only the _L bits are used.

If UNIFY = 0 in the CONFIG register, this register can be written to as two registers LIMIT_L and LIMIT_H. Both the L and H registers can be read or written individually or in a single 32-bit read or write operation.

The bits in this register set which events act as counter limits. When a limit event occurs, the counter is cleared to zero in unidirectional mode or begins counting down in bidirectional mode. When the counter reaches all ones, this state is always treated as a limit event, and the counter is cleared in unidirectional mode or, in bidirectional mode, begins counting down on the next clock edge - even if no limit event as defined by the SCT limit register has occurred.

Table 640. SCT limit register (LIMIT - address 0x4000 0008) bit description

Bit	Symbol	Description	Reset value
15:0	LIMMSK_L	If bit n is one, event n is used as a counter limit for the L or unified counter (event 0 = bit 0, event 1 = bit 1, event 15 = bit 15).	0
31:16	LIMMSK_H	If bit n is one, event n is used as a counter limit for the H counter (event 0 = bit 16, event 1 = bit 17, event 15 = bit 31).	0

28.6.4 SCT halt condition register

If UNIFY = 1 in the CONFIG register, only the _L bits are used.

If UNIFY = 0 in the CONFIG register, this register can be written to as two registers HALT_L and HALT_H. Both the L and H registers can be read or written individually or in a single 32-bit read or write operation.

Remark: Any event halting the counter disables its operation until software clears the HALT bit (or bits) in the CTRL register ([Table 639](#)).

Table 641. SCT halt condition register (HALT - address 0x4000 000C) bit description

Bit	Symbol	Description	Reset value
15:0	HALTMSK_L	If bit n is one, event n sets the HALT_L bit in the CTRL register (event 0 = bit 0, event 1 = bit 1, event 15 = bit 15).	0
31:16	HALTMSK_H	If bit n is one, event n sets the HALT_H bit in the CTRL register (event 0 = bit 16, event 1 = bit 17, event 15 = bit 31).	0

28.6.5 SCT stop condition register

If UNIFY = 1 in the CONFIG register, only the _L bits are used.

If UNIFY = 0 in the CONFIG register, this register can be written to as two registers STOPT_L and STOP_H. Both the L and H registers can be read or written individually or in a single 32-bit read or write operation.

Table 642. SCT stop condition register (STOP - address 0x4000 0010) bit description

Bit	Symbol	Description	Reset value
15:0	STOPMSK_L	If bit n is one, event n sets the STOP_L bit in the CTRL register (event 0 = bit 0, event 1 = bit 1, event 15 = bit 15).	0
31:16	STOPMSK_H	If bit n is one, event n sets the STOP_H bit in the CTRL register (event 0 = bit 16, event 1 = bit 17, event 15 = bit 31).	0

28.6.6 SCT start condition register

If UNIFY = 1 in the CONFIG register, only the _L bits are used.

If UNIFY = 0 in the CONFIG register, this register can be written to as two registers START_L and START_H. Both the L and H registers can be read or written individually or in a single 32-bit read or write operation.

The bits in this register select which events, if any, clear the STOP bit in the Control register. (Since no events can occur when HALT is 1, only software can clear the HALT bit by writing the Control register.)

Table 643. SCT start condition register (START - address 0x4000 0014) bit description

Bit	Symbol	Description	Reset value
15:0	STARTMSK_L	If bit n is one, event n clears the STOP_L bit in the CTRL register (event 0 = bit 0, event 1 = bit 1, event 15 = bit 15).	0
31:16	STARTMSK_H	If bit n is one, event n clears the STOP_H bit in the CTRL register (event 0 = bit 16, event 1 = bit 17, event 15 = bit 31).	0

28.6.7 SCT counter register

If UNIFY = 1 in the CONFIG register, the counter is a unified 32-bit register and both the _L and _H bits are used.

If UNIFY = 0 in the CONFIG register, this register can be written to as two registers COUNT_L and COUNT_H. Both the L and H registers can be read or written individually or in a single 32-bit read or write operation. In this case, the L and H registers count independently under the control of the other registers.

Attempting to write a counter while it is running does not affect the counter but produces a bus error. Software can read the counter registers at any time.

Table 644. SCT counter register (COUNT - address 0x4000 0040) bit description

Bit	Symbol	Description	Reset value
15:0	CTR_L	When UNIFY = 0, read or write the 16-bit L counter value. When UNIFY = 1, read or write the lower 16 bits of the 32-bit unified counter.	0
31:16	CTR_H	When UNIFY = 0, read or write the 16-bit H counter value. When UNIFY = 1, read or write the upper 16 bits of the 32-bit unified counter.	0

28.6.8 SCT state register

If UNIFY = 1 in the CONFIG register, only the _L bits are used.

If UNIFY = 0 in the CONFIG register, this register can be written to as two registers STATE_L and STATE_H. Both the L and H registers can be read or written individually or in a single 32-bit read or write operation.

Software can read the state associated with a counter at any time. Writing the state is only allowed when the counter HALT bit is 1; when HALT is 0, a write attempt does not change the state and results in a bus error.

The state variable is the main feature that distinguishes the SCT from other counter/timer/PWM blocks. Events can be made to occur only in certain states. Events, in turn, can perform the following actions:

- set and clear outputs
- limit, stop, and start the counter
- cause interrupts and DMA requests
- modify the state variable

The value of a state variable is completely under the control of the application. If an application does not use states, the value of the state variable remains zero, which is the default value.

A state variable can be used to track and control multiple cycles of the associated counter in any desired operational sequence. The state variable is logically associated with a state machine diagram which represents the SCT configuration. See [Section 28.6.23](#) and [28.6.24](#) for more about the relationship between states and events.

The STATELD/STADEV fields in the event control registers of all defined events set all possible values for the state variable. The change of the state variable during multiple counter cycles reflects how the associated state machine moves from one state to the next.

Table 645. SCT state register (STATE - address 0x4000 0044) bit description

Bit	Symbol	Description	Reset value
4:0	STATE_L	State variable.	0
15:5	-	Reserved.	-
20:16	STATE_H	State variable.	0
31:21	-	Reserved.	-

28.6.9 SCT input register

Software can read the state of the SCT inputs in this read-only register in two slightly different forms. The only situation in which these values are different is if CLKMODE = 2 in the CONFIG register.

Table 646. SCT input register (INPUT - address 0x4000 0048) bit description

Bit	Symbol	Description	Reset value
0	AIN0	Real-time status of input 0.	pin
1	AIN1	Real-time status of input 1.	pin
2	AIN2	Real-time status of input 2.	pin
3	AIN3	Real-time status of input 3.	pin
4	AIN4	Real-time status of input 4.	pin
5	AIN5	Real-time status of input 5.	pin
6	AIN6	Real-time status of input 6.	pin
7	AIN7	Real-time status of input 7.	pin
15:8	-	Reserved.	-
16	SIN0	Input 0 state synchronized to the SCT clock.	-
17	SIN1	Input 1 state synchronized to the SCT clock.	-
18	SIN2	Input 2 state synchronized to the SCT clock.	-
19	SIN3	Input 3 state synchronized to the SCT clock.	-
20	SIN4	Input 4 state synchronized to the SCT clock.	-
21	SIN5	Input 5 state synchronized to the SCT clock.	-
22	SIN6	Input 6 state synchronized to the SCT clock.	-
23	SIN7	Input 7 state synchronized to the SCT clock.	-
31:24	-	Reserved	-

28.6.10 SCT match/capture registers mode register

If UNIFY = 1 in the CONFIG register, only the _L bits of this register are used. The L bits control whether each set of match/capture registers operates as unified 32-bit capture/match registers.

If UNIFY = 0 in the CONFIG register, this register can be written to as two registers REGMODE_L and REGMODE_H. Both the L and H registers can be read or written individually or in a single 32-bit read or write operation. The _L bits/register control the L match/capture registers, and the _H bits/register control the H match/capture registers.

The SCT contains 16 Match/Capture register pairs. The Register Mode register selects whether each register pair acts as a Match register (see [Section 28.6.19](#)) or as a Capture register (see [Section 28.6.20](#)). Each Match/Capture register has an accompanying register which serves as a Reload register when the register is used as a Match register ([Section 28.6.21](#)) or as a Capture-Control register when the register is used as a capture register ([Section 28.6.22](#)). REGMODE_H is used only when the UNIFY bit is 0.

An alternate addressing mode is available for all of the Match/Capture and Reload/Capture-Control registers, for DMA access to halfword registers when UNIFY=0. This mode is described in [Section 28.7.9](#).

Table 647. SCT match/capture registers mode register (REGMODE - address 0x4000 004C) bit description

Bit	Symbol	Description	Reset value
15:0	REGMOD_L	Each bit controls one pair of match/capture registers (register 0 = bit 0, register 1 = bit 1, ..., register 15 = bit 15). 0 = registers operate as match registers. 1 = registers operate as capture registers.	0
31:16	REGMOD_H	Each bit controls one pair of match/capture registers (register 0 = bit 16, register 1 = bit 17, ..., register 15 = bit 31). 0 = registers operate as match registers. 1 = registers operate as capture registers.	0

28.6.11 SCT output register

The SCT supports 16 outputs, each of which has a corresponding bit in this register. Software can write to any of the output registers when both counters are halted to control the outputs directly. Writing to this register when either counter is stopped or running does not affect the outputs and results in a bus error.

Software can read this register at any time to sense the state of the outputs.

Table 648. SCT output register (OUTPUT - address 0x4000 0050) bit description

Bit	Symbol	Description	Reset value
15:0	OUT	Writing a 1 to bit n makes the corresponding output HIGH. 0 makes the corresponding output LOW (output 0 = bit 0, output 1 = bit 1, ..., output 15 = bit 15).	0
31:16	-	Reserved	

28.6.12 SCT bidirectional output control register

This register specifies (for each output) the impact of the counting direction on the meaning of set and clear operations on the output (see [Section 28.6.25](#) and [Section 28.6.26](#)).

Table 649. SCT bidirectional output control register (OUTPUTDIRCTRL - address 0x4000 0054) bit description

Bit	Symbol	Value	Description	Reset value
1:0	SETCLR0		Set/clear operation on output 0. Value 0x3 is reserved. Do not program this value.	0
		0x0	Set and clear do not depend on any counter.	
		0x1	Set and clear are reversed when counter L or the unified counter is counting down.	
		0x2	Set and clear are reversed when counter H is counting down. Do not use if UNIFY = 1.	
3:2	SETCLR1		Set/clear operation on output 1. Value 0x3 is reserved. Do not program this value.	0
		0x0	Set and clear do not depend on any counter.	
		0x1	Set and clear are reversed when counter L or the unified counter is counting down.	
		0x2	Set and clear are reversed when counter H is counting down. Do not use if UNIFY = 1.	
5:4	SETCLR2		Set/clear operation on output 2. Value 0x3 is reserved. Do not program this value.	0
		0x0	Set and clear do not depend on any counter.	
		0x1	Set and clear are reversed when counter L or the unified counter is counting down.	
		0x2	Set and clear are reversed when counter H is counting down. Do not use if UNIFY = 1.	
7:6	SETCLR3		Set/clear operation on output 3. Value 0x3 is reserved. Do not program this value.	0
		0x0	Set and clear do not depend on any counter.	
		0x1	Set and clear are reversed when counter L or the unified counter is counting down.	
		0x2	Set and clear are reversed when counter H is counting down. Do not use if UNIFY = 1.	
9:8	SETCLR4		Set/clear operation on output 4. Value 0x3 is reserved. Do not program this value.	0
		0x0	Set and clear do not depend on any counter.	
		0x1	Set and clear are reversed when counter L or the unified counter is counting down.	
		0x2	Set and clear are reversed when counter H is counting down. Do not use if UNIFY = 1.	
11: 10	SETCLR5		Set/clear operation on output 5. Value 0x3 is reserved. Do not program this value.	0
		0x0	Set and clear do not depend on any counter.	
		0x1	Set and clear are reversed when counter L or the unified counter is counting down.	
		0x2	Set and clear are reversed when counter H is counting down. Do not use if UNIFY = 1.	
13: 12	SETCLR6		Set/clear operation on output 6. Value 0x3 is reserved. Do not program this value.	0
		0x0	Set and clear do not depend on any counter.	
		0x1	Set and clear are reversed when counter L or the unified counter is counting down.	
		0x2	Set and clear are reversed when counter H is counting down. Do not use if UNIFY = 1.	
15: 14	SETCLR7		Set/clear operation on output 7. Value 0x3 is reserved. Do not program this value.	0
		0x0	Set and clear do not depend on any counter.	
		0x1	Set and clear are reversed when counter L or the unified counter is counting down.	
		0x2	Set and clear are reversed when counter H is counting down. Do not use if UNIFY = 1.	
17: 16	SETCLR8		Set/clear operation on output 8. Value 0x3 is reserved. Do not program this value.	0
		0x0	Set and clear do not depend on any counter.	
		0x1	Set and clear are reversed when counter L or the unified counter is counting down.	
		0x2	Set and clear are reversed when counter H is counting down. Do not use if UNIFY = 1.	
19: 18	SETCLR9		Set/clear operation on output 9. Value 0x3 is reserved. Do not program this value.	0
		0x0	Set and clear do not depend on any counter.	
		0x1	Set and clear are reversed when counter L or the unified counter is counting down.	
		0x2	Set and clear are reversed when counter H is counting down. Do not use if UNIFY = 1.	

Table 649. SCT bidirectional output control register (OUTPUTDIRCTRL - address 0x4000 0054) bit description

Bit	Symbol	Value	Description	Reset value
21: 20	SETCLR10		Set/clear operation on output 5. Value 0x3 is reserved. Do not program this value.	0
		0x0	Set and clear do not depend on any counter.	
		0x1	Set and clear are reversed when counter L or the unified counter is counting down.	
		0x2	Set and clear are reversed when counter H is counting down. Do not use if UNIFY = 1.	
23: 22	SETCLR11		Set/clear operation on output 11. Value 0x3 is reserved. Do not program this value.	0
		0x0	Set and clear do not depend on any counter.	
		0x1	Set and clear are reversed when counter L or the unified counter is counting down.	
		0x2	Set and clear are reversed when counter H is counting down. Do not use if UNIFY = 1.	
25: 24	SETCLR12		Set/clear operation on output 12. Value 0x3 is reserved. Do not program this value.	0
		0x0	Set and clear do not depend on any counter.	
		0x1	Set and clear are reversed when counter L or the unified counter is counting down.	
		0x2	Set and clear are reversed when counter H is counting down. Do not use if UNIFY = 1.	
27: 26	SETCLR13		Set/clear operation on output 13. Value 0x3 is reserved. Do not program this value.	0
		0x0	Set and clear do not depend on any counter.	
		0x1	Set and clear are reversed when counter L or the unified counter is counting down.	
		0x2	Set and clear are reversed when counter H is counting down. Do not use if UNIFY = 1.	
29: 28	SETCLR14		Set/clear operation on output 14. Value 0x3 is reserved. Do not program this value.	0
		0x0	Set and clear do not depend on any counter.	
		0x1	Set and clear are reversed when counter L or the unified counter is counting down.	
		0x2	Set and clear are reversed when counter H is counting down. Do not use if UNIFY = 1.	
31: 30	SETCLR15		Set/clear operation on output 15. Value 0x3 is reserved. Do not program this value.	0
		0x0	Set and clear do not depend on any counter.	
		0x1	Set and clear are reversed when counter L or the unified counter is counting down.	
		0x2	Set and clear are reversed when counter H is counting down. Do not use if UNIFY = 1.	

28.6.13 SCT conflict resolution register

The registers OUTPUTSETn ([Section 28.6.25](#)) and OUTPUTCLn ([Section 28.6.26](#)) allow both setting and clearing to be indicated for an output in the same clock cycle, even for the same event. This SCT conflict resolution register resolves this conflict.

To enable an event to toggle an output, set the OnRES value to 0x3 in this register, and set the event bits in both the Set and Clear registers.

Table 650. SCT conflict resolution register (RES - address 0x4000 0058) bit description

Bit	Symbol	Value	Description	Reset value
1:0	O0RES		Effect of simultaneous set and clear on output 0.	0
		0x0	No change.	
		0x1	Set output (or clear based on the SETCLR0 field).	
		0x2	Clear output (or set based on the SETCLR0 field).	
		0x3	Toggle output.	

Table 650. SCT conflict resolution register (RES - address 0x4000 0058) bit description

Bit	Symbol	Value	Description	Reset value
3:2	O1RES		Effect of simultaneous set and clear on output 1.	0
		0x0	No change.	
		0x1	Set output (or clear based on the SETCLR1 field).	
		0x2	Clear output (or set based on the SETCLR1 field).	
		0x3	Toggle output.	
5:4	O2RES		Effect of simultaneous set and clear on output 2.	0
		0x0	No change.	
		0x1	Set output (or clear based on the SETCLR2 field).	
		0x2	Clear output n (or set based on the SETCLR2 field).	
		0x3	Toggle output.	
7:6	O3RES		Effect of simultaneous set and clear on output 3.	0
		0x0	No change.	
		0x1	Set output (or clear based on the SETCLR3 field).	
		0x2	Clear output (or set based on the SETCLR3 field).	
		0x3	Toggle output.	
9:8	O4RES		Effect of simultaneous set and clear on output 4.	0
		0x0	No change.	
		0x1	Set output (or clear based on the SETCLR4 field).	
		0x2	Clear output (or set based on the SETCLR4 field).	
		0x3	Toggle output.	
11: 10	O5RES		Effect of simultaneous set and clear on output 5.	0
		0x0	No change.	
		0x1	Set output (or clear based on the SETCLR5 field).	
		0x2	Clear output (or set based on the SETCLR5 field).	
		0x3	Toggle output.	
13: 12	O6RES		Effect of simultaneous set and clear on output 6.	0
		0x0	No change.	
		0x1	Set output (or clear based on the SETCLR6 field).	
		0x2	Clear output (or set based on the SETCLR6 field).	
		0x3	Toggle output.	
15: 14	O7RES		Effect of simultaneous set and clear on output 7.	0
		0x0	No change.	
		0x1	Set output (or clear based on the SETCLR7 field).	
		0x2	Clear output (or set based on the SETCLR7 field).	
		0x3	Toggle output.	
17: 16	O8RES		Effect of simultaneous set and clear on output 8.	0
		0x0	No change.	
		0x1	Set output (or clear based on the SETCLR8 field).	
		0x2	Clear output (or set based on the SETCLR8 field).	
		0x3	Toggle output.	

Table 650. SCT conflict resolution register (RES - address 0x4000 0058) bit description

Bit	Symbol	Value	Description	Reset value
19: 18	O9RES		Effect of simultaneous set and clear on output 9.	0
		0x0	No change.	
		0x1	Set output (or clear based on the SETCLR9 field).	
		0x2	Clear output (or set based on the SETCLR9 field).	
		0x3	Toggle output.	
21: 20	O10RES		Effect of simultaneous set and clear on output 10.	0
		0x0	No change.	
		0x1	Set output (or clear based on the SETCLR10 field).	
		0x2	Clear output (or set based on the SETCLR10 field).	
		0x3	Toggle output.	
23: 22	O11RES		Effect of simultaneous set and clear on output 11.	0
		0x0	No change.	
		0x1	Set output (or clear based on the SETCLR11 field).	
		0x2	Clear output (or set based on the SETCLR11 field).	
		0x3	Toggle output.	
25: 24	O12RES		Effect of simultaneous set and clear on output 12.	0
		0x0	No change.	
		0x1	Set output (or clear based on the SETCLR12 field).	
		0x2	Clear output (or set based on the SETCLR12 field).	
		0x3	Toggle output.	
27: 26	O13RES		Effect of simultaneous set and clear on output 13.	0
		0x0	No change.	
		0x1	Set output (or clear based on the SETCLR13 field).	
		0x2	Clear output (or set based on the SETCLR13 field).	
		0x3	Toggle output.	
29: 28	O14RES		Effect of simultaneous set and clear on output 14.	0
		0x0	No change.	
		0x1	Set output (or clear based on the SETCLR14 field).	
		0x2	Clear output (or set based on the SETCLR14 field).	
		0x3	Toggle output.	
31: 30	O15RES		Effect of simultaneous set and clear on output 15.	0
		0x0	No change.	
		0x1	Set output (or clear based on the SETCLR15 field).	
		0x2	Clear output (or set based on the SETCLR15 field).	
		0x3	Toggle output.	

28.6.14 SCT DMA request 0 and 1 registers

The SCT includes two DMA request outputs. These registers enable the DMA requests to be triggered when a particular event occurs or when counter Match registers are loaded from its Reload registers.

Table 651. SCT DMA 0 request register (DMAREQ0 - address 0x4000 005C) bit description

Bit	Symbol	Description	Reset value
15:0	DEV_0	If bit n is one, event n sets DMA request 0 (event 0 = bit 0, event 1 = bit 1,..., event 15 = bit 15).	0
29:16	-	Reserved	-
30	DRL0	A 1 in this bit makes the SCT set DMA request 0 when it loads the Match_L/Unified registers from the Reload_L/Unified registers.	
31	DRQ0	This read-only bit indicates the state of DMA Request 0	

Table 652. SCT DMA 1 request register (DMAREQ1 - address 0x4000 0060) bit description

Bit	Symbol	Description	Reset value
15:0	DEV_1	If bit n is one, event n sets DMA request 1 (event 0 = bit 0, event 1 = bit 1,..., event 15 = bit 15).	0
29:16	-	Reserved	-
30	DRL1	A 1 in this bit makes the SCT set DMA request 1 when it loads the Match L/Unified registers from the Reload L/Unified registers.	
31	DRQ1	This read-only bit indicates the state of DMA Request 1.	

28.6.15 SCT flag enable register

This register enables flags to request an interrupt if the FLAGn bit in the SCT event flag register ([Section 28.6.16](#)) is also set.

Table 653. SCT flag enable register (EVEN - address 0x4000 00F0) bit description

Bit	Symbol	Description	Reset value
15:0	IEN	The SCT requests interrupt when bit n of this register and the event flag register are both one (event 0 = bit 0, event 1 = bit 1,..., event 15 = bit 15).	0
31:16	-	Reserved	

28.6.16 SCT event flag register

This register records events. Writing ones to this register clears the corresponding flags and negates the SCT interrupt request if all enabled Flag bits are zero.

Table 654. SCT event flag register (EVFLAG - address 0x4000 00F4) bit description

Bit	Symbol	Description	Reset value
15:0	FLAG	Bit n is one if event n has occurred since reset or a 1 was last written to this bit (event 0 = bit 0, event 1 = bit 1,..., event 15 = bit 15).	0
31:16	-	Reserved	-

28.6.17 SCT conflict enable register

This register enables the “no change conflict” events specified in the SCT conflict resolution register to request an IRQ.

Table 655. SCT conflict enable register (CONEN - address 0x4000 00F8) bit description

Bit	Symbol	Description	Reset value
15:0	NCEN	The SCT requests interrupt when bit n of this register and the SCT conflict flag register are both one (output 0 = bit 0, output 1 = bit 1, ..., output 15 = bit 15).	0
31:16	-	Reserved	

28.6.18 SCT conflict flag register

This register records interrupt-enabled no-change conflict events and provides details of a bus error. Writing ones to the NCFLAG bits clears the corresponding read bits and negates the SCT interrupt request if all enabled Flag bits are zero.

Table 656. SCT conflict flag register (CONFLAG - address 0x4000 00FC) bit description

Bit	Symbol	Description	Reset value
15:0	NCFLAG	Bit n is one if a no-change conflict event occurred on output n since reset or a 1 was last written to this bit (output 0 = bit 0, output 1 = bit 1, ..., output 15 = bit 15).	0
29:16	-	Reserved.	-
30	BUSERRL	The most recent bus error from this SCT involved writing CTR L/Unified, STATE L/Unified, MATCH L/Unified, or the Output register when the L/U counter was not halted. A word write to certain L and H registers can be half successful and half unsuccessful.	0
31	BUSERRH	The most recent bus error from this SCT involved writing CTR H, STATE H, MATCH H, or the Output register when the H counter was not halted.	0

28.6.19 SCT match registers 0 to 15 (REGMODEn bit = 0)

Match registers are compared to the counters to help create events. When the UNIFY bit is 0, the L and H registers are independently compared to the L and H counters. When UNIFY is 1, the L and H registers hold a 32-bit value that is compared to the unified counter. A Match can only occur in a clock in which the counter is running (STOP and HALT are both 0).

Match registers can be read at any time. Writing to a Match register while the associated counter is running does not affect the Match register and results in a bus error. Match events occur in the SCT clock in which the counter is (or would be) incremented to the next value. When a Match event limits its counter as described in [Section 28.6.3](#), the value in the Match register is the last value of the counter before it is cleared to zero (or decremented if BIDIR is 1).

There is no “write-through” from Reload registers to Match registers. Before starting a counter, software can write one value to the Match register used in the first cycle of the counter and a different value to the corresponding Match Reload register used in the second cycle.

Table 657. SCT match registers 0 to 15 (MATCH - address 0x4000 0100 (MATCH0) to 0x4000 4013C (MATCH15)) bit description (REGMODEn bit = 0)

Bit	Symbol	Description	Reset value
15:0	MATCHn_L	When UNIFY = 0, read or write the 16-bit value to be compared to the L counter. When UNIFY = 1, read or write the lower 16 bits of the 32-bit value to be compared to the unified counter.	0
31:16	MATCHn_H	When UNIFY = 0, read or write the 16-bit value to be compared to the H counter. When UNIFY = 1, read or write the upper 16 bits of the 32-bit value to be compared to the unified counter.	0

28.6.20 SCT capture registers 0 to 15 (REGMODEn bit = 1)

These registers allow software to read the counter values at which the event selected by the corresponding Capture Control registers occurred.

Table 658. SCT capture registers 0 to 15 (CAP - address 0x4000 0100 (CAP0) to 0x4000 013C (CAP15)) bit description (REGMODEn bit = 1)

Bit	Symbol	Description	Reset value
15:0	CAPn_L	When UNIFY = 0, read the 16-bit counter value at which this register was last captured. When UNIFY = 1, read the lower 16 bits of the 32-bit value at which this register was last captured.	0
31:16	CAPn_H	When UNIFY = 0, read the 16-bit counter value at which this register was last captured. When UNIFY = 1, read the upper 16 bits of the 32-bit value at which this register was last captured.	0

28.6.21 SCT match reload registers 0 to 15 (REGMODEn bit = 0)

A Match register (L, H, or unified 32-bit) is loaded from the corresponding Reload register when BIDIR is 0 and the counter reaches its limit condition, or when BIDIR is 1 and the counter reaches 0.

Table 659. SCT match reload registers 0 to 15 (MATCHREL- address 0x4000 0200 (MATCHRELOAD0) to 0x4000 023C (MATCHRELOAD15)) bit description (REGMODEn bit = 0)

Bit	Symbol	Description	Reset value
15:0	RELOADn_L	When UNIFY = 0, read or write the 16-bit value to be loaded into the SCTMATCHn_L register. When UNIFY = 1, read or write the lower 16 bits of the 32-bit value to be loaded into the MATCHn register.	0
31:16	RELOADn_H	When UNIFY = 0, read or write the 16-bit to be loaded into the MATCHn_H register. When UNIFY = 1, read or write the upper 16 bits of the 32-bit value to be loaded into the MATCHn register.	0

28.6.22 SCT capture control registers 0 to 15 (REGMODEn bit = 1)

If UNIFY = 1 in the CONFIG register, only the _L bits are used.

If UNIFY = 0 in the CONFIG register, this register can be written to as two registers CAPCTRLn_L and CAPCTRLn_H. Both the L and H registers can be read or written individually or in a single 32-bit read or write operation.

Each Capture Control register (L, H, or unified 32-bit) controls which events load the corresponding Capture register from the counter.

Table 660. SCT capture control registers 0 to 15 (CAPCTRL- address 0x4000 0200 (CAPCTRL0) to 0x4000 023C (CAPCTRL15)) bit description (REGMODEn bit = 1)

Bit	Symbol	Description	Reset value
15:0	CAPCONn_L	If bit m is one, event m causes the CAPn_L (UNIFY = 0) or the CAPn (UNIFY = 1) register to be loaded (event 0 = bit 0, event 1 = bit 1, ..., event 15 = bit 15).	0
31:16	CAPCONn_H	If bit m is one, event m causes the CAPn_H (UNIFY = 0) register to be loaded (event 0 = bit 16, event 1 = bit 17, ..., event 15 = bit 31).	0

28.6.23 SCT event state mask registers 0 to 15

Each event has one associated SCT event state mask register that allow this event to happen in one or more states of the counter selected by the HEVENT bit in the corresponding EVCTRLn register.

An event n is disabled when its EVSTATEMSKn register contains all zeros, since it is masked regardless of the current state.

In simple applications that do not use states, write 0x01 to this register to enable an event. Since the state always remains at its reset value of 0, writing 0x01 effectively permanently state-enables this event.

Table 661. SCT event state mask registers 0 to 15 (EVSTATEMSK - addresses 0x4000 0300 (EVSTATEMSK0) to 0x4000 0378 (EVSTATEMSK15)) bit description

Bit	Symbol	Description	Reset value
31:0	STATEMSKn	If bit m is one, event n (n= 0 to 15) happens in state m of the counter selected by the HEVENT bit (m = state number; state 0 = bit 0, state 1= bit 1, ..., state 31 = bit 31).	0

28.6.24 SCT event control registers 0 to 15

This register defines the conditions for event n to occur, other than the state variable which is defined by the state mask register. Most events are associated with a particular counter (high, low, or unified), in which case the event can depend on a match to that register. The other possible ingredient of an event is a selected input or output signal.

When the UNIFY bit is 0, each event is associated with a particular counter by the HEVENT bit in its event control register. An event cannot occur when its related counter is halted nor when the current state is not enabled to cause the event as specified in its event mask register. An event is permanently disabled when its event state mask register contains all 0s.

An enabled event can be programmed to occur based on a selected input or output edge or level and/or based on its counter value matching a selected match register.

Each event can modify its counter STATE value. If more than one event associated with the same counter occurs in a given clock cycle, only the state change specified for the highest-numbered event among them takes place. Other actions dictated by any simultaneously occurring events all take place.

Table 662. SCT event control register 0 to 15 (EVCTRL - address 0x4000 0304 (EVCTRL0) to 0x4000 037C (EVCTRL15)) bit description

Bit	Symbol	Value	Description	Reset value
3:0	MATCHSEL	-	Selects the Match register associated with this event (if any). A match can occur only when the counter selected by the HEVENT bit is running.	0
4	HEVENT	-	Select L/H counter. Do not set this bit if UNIFY = 1.	0
		0	Selects the L state and the L match register selected by MATCHSEL.	
		1	Selects the H state and the H match register selected by MATCHSEL.	
5	OUTSEL	-	Input/output select	0
		0	Selects the input selected by IOSEL.	
		1	Selects the output selected by IOSEL.	
9:6	IOSEL	-	Selects the input or output signal associated with this event (if any). Do not select an input in this register, if CKMODE is 1x. In this case the clock input is an implicit ingredient of every event.	0
11:10	IOCOND	-	Selects the I/O condition for event n. (The detection of edges on outputs lag the conditions that switch the outputs by one SCT clock). In order to guarantee proper edge/state detection, an input must have a minimum pulse width of at least one SCT clock period .	0
		0x0	LOW	
		0x1	Rise	
		0x2	Fall	
		0x3	HIGH	
13:12	COMBMODE	-	Selects how the specified match and I/O condition are used and combined.	0
		0x0	OR. The event occurs when either the specified match or I/O condition occurs.	
		0x1	MATCH. Uses the specified match only.	
		0x2	IO. Uses the specified I/O condition only.	
		0x3	AND. The event occurs when the specified match and I/O condition occur simultaneously.	

Table 662. SCT event control register 0 to 15 (EVCTRL - address 0x4000 0304 (EVCTRL0) to 0x4000 037C (EVCTRL15)) bit description

Bit	Symbol	Value	Description	Reset value
14	STATELD		This bit controls how the STATEV value modifies the state selected by HEVENT when this event is the highest-numbered event occurring for that state.	0
		0	STATEV value is added into STATE (the carry-out is ignored).	
		1	STATEV value is loaded into STATE.	
19:15	STATEV		This value is loaded into or added to the state selected by HEVENT, depending on STATELD, when this event is the highest-numbered event occurring for that state. If STATELD and STATEV are both zero, there is no change to the STATE value.	0
31:20	-		Reserved	-

28.6.25 SCT output set registers 0 to 15

Each output n has one set register that controls how events affect each output. Whether outputs are set or cleared depends on the setting of the SETCLRn field in the SCTOUTPUTDIRCTRL register.

Table 663. SCT output set register 0 to 15 (OUTPUTSET - address 0x4000 0500 (OUTPUTSET0) to 0x4000 0578 (OUTPUTSET15)) bit description

Bit	Symbol	Description	Reset value
15:0	SET	A 1 in bit m selects event m to set output n (or clear it if SETCLRn = 0x1 or 0x2) event 0 = bit 0, event 1 = bit 1, ..., event 15 = bit 15.	0
31:16	-	Reserved	

28.6.26 SCT output clear registers 0 to 15

Each output n has one clear register that controls how events affect each output. Whether outputs are set or cleared depends on the setting of the SETCLRn field in the OUTPUTDIRCTRL register.

Table 664. SCT output clear register 0 to 15 (OUTPUTCL - address 0x4000 0504 (OUTPUTCL0) to 0x4000 057C (OUTPUTCL15)) bit description

Bit	Symbol	Description	Reset value
15:0	CLR	A 1 in bit m selects event m to clear output n (or set it if SETCLRn = 0x1 or 0x2) event 0 = bit 0, event 1 = bit 1, ..., event 15 = bit 15.	0
31:16	-	Reserved	

28.7 Functional description

28.7.1 Match logic

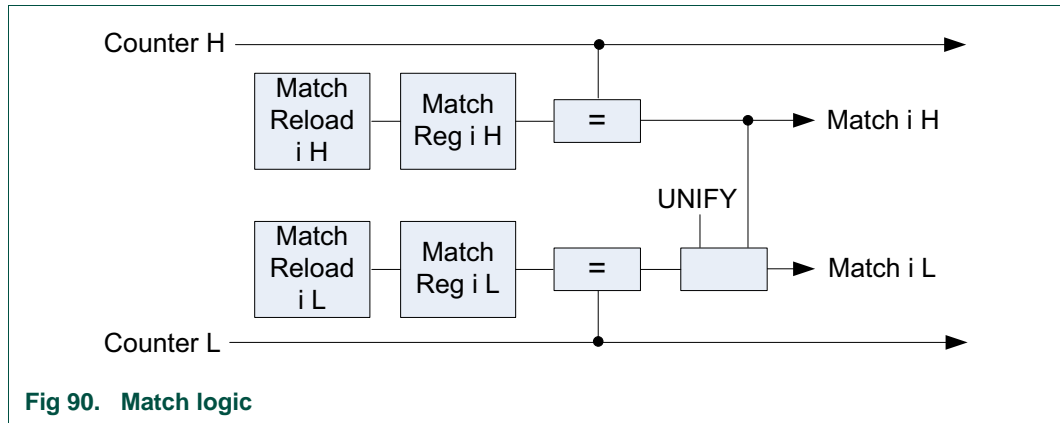

28.7.2 Capture logic

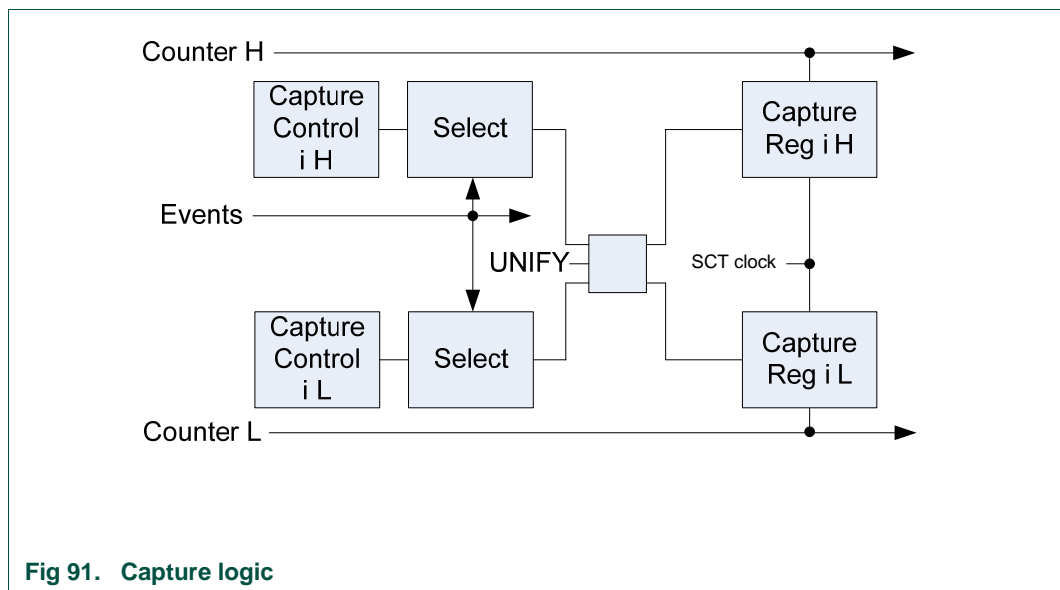

28.7.3 Event selection

State variables allow control of the SCT across more than one cycle of the counter. Counter matches, input/output edges, and state values are combined into a set of general-purpose events that can switch outputs, request interrupts, and change state values.

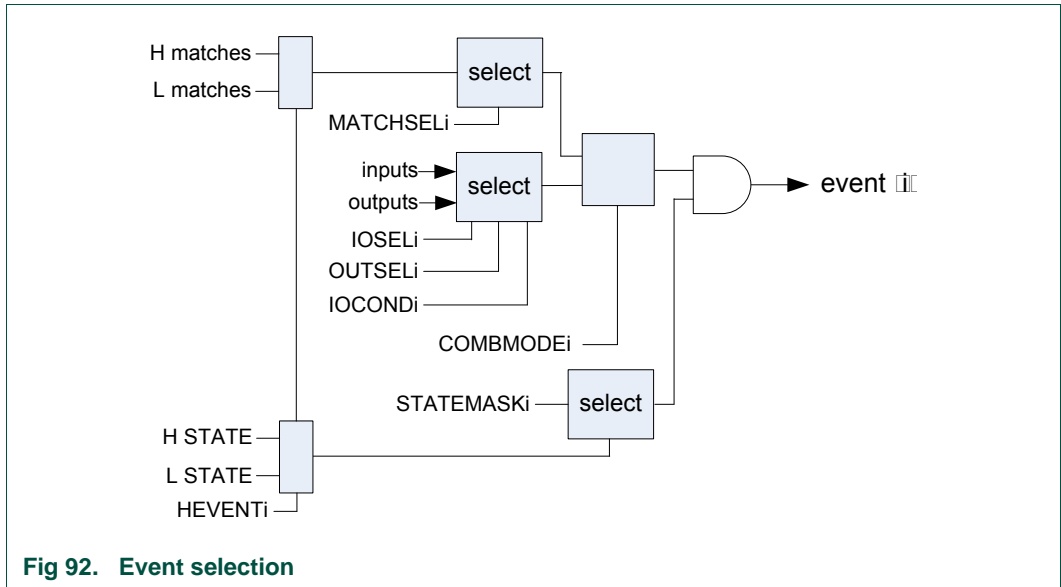

28.7.4 Output generation

Figure 93 shows one output slice of the SCT.

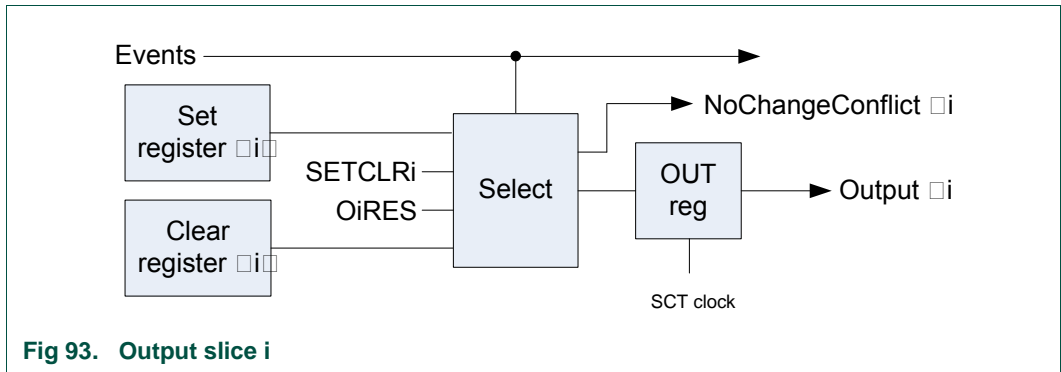

28.7.5 Interrupt generation

The SCT generates one interrupt to the NVIC.

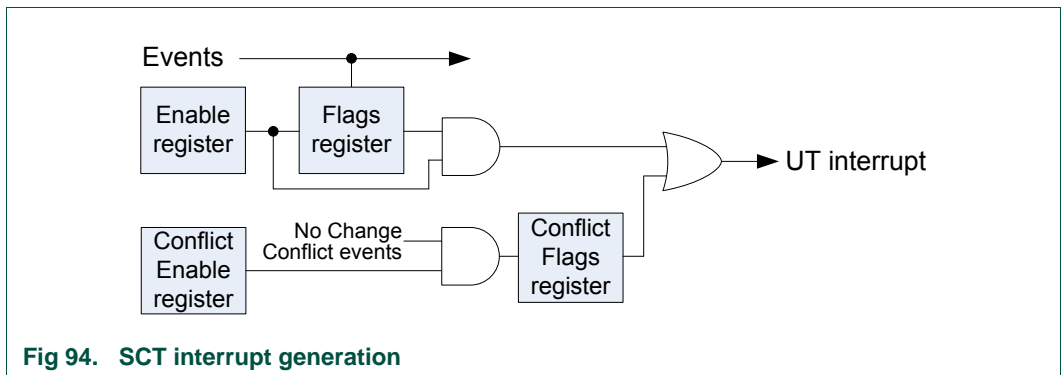

28.7.6 Clearing the prescaler

When enabled by a non-zero PRE field in the Control register, the prescaler acts as a clock divider for the counter, like a fractional part of the counter value. The prescaler is cleared whenever the counter is cleared or loaded for any of the following reasons:

- Hardware reset
- Software writing to the counter register
- Software writing a 1 to the CLRCTR bit in the control register
- an event selected by a 1 in the counter limit register when BIDIR = 0

When BIDIR is 0, a limit event caused by an I/O signal can clear a non-zero prescaler. However, a limit event caused by a Match only clears a non-zero prescaler in one special case as described [Section 28.7.7](#).

A limit event when BIDIR is 1 does not clear the prescaler. Rather it clears the DOWN bit in the Control register, and decrements the counter on the same clock if the counter is enabled in that clock.

28.7.7 Match vs. I/O events

Counter operation is complicated by the prescaler and by clock mode 01 in which the SCT clock is the bus clock. However, the prescaler and counter are enabled to count only when a selected edge is detected on a clock input.

- The prescaler is enabled when the clock mode is not 01, or when the input edge selected by the CLKSEL field is detected.
- The counter is enabled when the prescaler is enabled, and (PRELIM=0 or the prescaler is equal to the value in PRELIM).

An I/O component of an event can occur in any SCT clock when its counter HALT bit is 0. In general, a Match component of an event can only occur in a UT clock when its counter HALT and STOP bits are both 0 and the counter is enabled.

[Table 665](#) shows when the various kinds of events can occur.

Table 665. Event conditions

COMBMODE	IOMODE	Event can occur on clock:
IO	Any	Event can occur whenever HALT = 0 (type A).
MATCH	Any	Event can occur when HALT = 0 and STOP = 0 and the counter is enabled (type C).
OR	Any	From the IO component: Event can occur whenever HALT = 0 (A). From the match component: Event can occur when HALT = 0 and STOP = 0 and the counter is enabled (C).
AND	LOW or HIGH	Event can occur when HALT = 0 and STOP = 0 and the counter is enabled (C).
AND	RISE or FALL	Event can occur whenever HALT = 0 (A).

28.7.8 DMA operation

A DMA controller can be used to write one or more Reload registers, or read one or more Capture registers, typically at the start of a counter cycle.

DMA access to more than one Reload or Capture register requires that they be consecutive registers. (Nothing else in the SCT constrains how these registers are assigned and used.)

Remark: The SCT can also be used to launch timed or other event-determined transfers among other peripherals or between other peripherals and memory. It is not necessary to transfer data in and out of the SCT in response to a DMA request.

An event can set a DMA request or set when a counter Match registers are loaded from its Reload registers, as described in [Section 28.6.14](#). The two requests of the SCT can be used to do the same register access for both counters when UNIFY is 0. Alternatively, one request can be used for writing Reload registers and the other for reading Capture registers.

The SCT does not know how many transfers are done for each request, so it cannot control its DMA requests accordingly.

The two DMA requests are connected to DMABREQ7 and DMABREQ8. Write the number of registers to be transferred for each request to the TransferSize field in the Channel Control Register of the DMA channel to which the request is connected. If the Linked List feature is used, there is a TransferSize value in each Linked List entry. The GPDMA asserts the DMACCLR signal when that number of transfers has been completed, which makes the SCT clear the request.

28.7.9 Alternate addressing for match/capture registers

The Match, Reload, Capture, and Capture Control registers are arranged as consecutive words, with the standard division of each word into two halfwords. When the UNIFY bit is zero, these two halfwords are related to the L and H counters. Software has the option of writing words initially to set up both halves of a SCT simultaneously, or writing halfwords to set up each half separately.

Applications can use a DMA controller to write Reload registers or to read Capture registers. However, when UNIFY is 0, the addressing of the halfword registers is not compatible with the requirement of many DMA controllers to use consecutive addresses for sequential address operation. [Table 666](#) shows how the second half of the range occupied by each type of register contains an alternate address map for halfword accesses to the same registers, which is compatible with DMA that use sequential address operation. When UNIFY is 1, perform DMA word accesses using standard offsets.

Table 666. Alternate address map for DMA halfword access

Match register	Capture register	Standard offset	DMA halfword offset
MATCH0_L	CAP0_L	0x100	0x180
MATCH0_H	CAP0_H	0x102	0x1C0
MATCH1_L	CAP1_L	0x104	0x182
MATCH1_H	CAP1_H	0x106	0x1C2
...
MATCHRELO_L	CAPCTRL0_L	0x200	0x280
MATCHRELO_H	CAPCTRL0_H	0x202	0x2C0

Table 666. Alternate address map for DMA halfword access

Match register	Capture register	Standard offset	DMA halfword offset
MATCHREL1_L	CAPCTRL1_L	0x204	0x282
MATCHREL1_H	CAPCTRL1_H	0x206	0x2C2
...

28.7.10 SCT operation

In its simplest, single-state configuration, the SCT operates as an event controlled one- or bidirectional counter. Events can be configured to be counter match events, an input or output level, transitions on an input or output pin, or a combination of match and input/output behavior. In response to an event, the SCT output or outputs can transition, or the SCT can perform other actions such as creating an interrupt or starting, stopping, or resetting the counter. Multiple simultaneous actions are allowed for each event. Furthermore, any number of events can trigger one specific action of the SCT.

An action or multiple actions of the SCT uniquely define an event. A state is defined by which events are enabled to trigger an SCT action or actions in any stage of the counter. Events not selected for this state are ignored.

In a multi-state configuration, states change in response to events. A state change is an additional action that the SCT can perform when the event occurs. When an event is configured to change the state, the new state defines a new set of events resulting in different actions of the SCT. Through multiple cycles of the counter, events can change the state multiple times and thus create a large variety of event controlled transitions on the SCT outputs and/or interrupts.

Once configured, the SCT can run continuously without software intervention and can generate multiple output patterns entirely under the control of events.

- To configure the SCT, see [Section 28.7.10.1](#).
- To start, run, and stop the SCT, see [Section 28.7.10.2](#).
- To configure the SCT as simple event controlled counter/timer, see [Section 28.7.10.3](#).

28.7.10.1 Configure the SCT

To set up the SCT for multiple events and states, perform the following configuration steps:

28.7.10.1.1 Configure the counter

1. Configure the L and H counters in the CONFIG register by selecting two independent 16-bit counters (L counter and H counter) or one combined 32-bit counter in the UNIFY field.
2. Select the SCT clock source in the CONFIG register (fields CLKMODE and CLKSEL) from any of the inputs or an internal clock.

28.7.10.1.2 Configure the match and capture registers

1. Select how many match and capture registers the application uses (total of up to 16):
 - In the REGMODE register, select for each of the 16 match/capture register pairs whether the register is used as a match register or capture register.
2. Define match conditions for each match register selected:
 - Each match register MATCH sets one match value, if a 32-bit counter is used, or two match values, if the L and H 16-bit counters are used.
 - Each match reload register MATCHRELOAD sets a reload value that is loaded into the match register when the counter reaches a limit condition or the value 0.

28.7.10.1.3 Configure events and event responses

1. Define when each event can occur in the following way in the EVCTRL registers (up to 16, one register per event):
 - Select whether the event occurs on an input or output changing, on an input or output level, a match condition of the counter, or a combination of match and input/output conditions in field COMBMODE.
 - For a match condition:

Select the match register that contains the match condition for the event to occur. Enter the number of the selected match register in field MATCHSEL.

If using L and H counters, define whether the event occurs on matching the L or the H counter in field HEVENT.
 - For an SCT input or output level or transition:

Select the input number or the output number that is associated with this event in fields IOSEL and OUTSEL.

Define how the selected input or output triggers the event (edge or level sensitive) in field IOCOND.
2. Define what the effect of each event is on the SCT outputs in the OUTPUTSET or OUTPUTCLR registers (up to 16 outputs, one register per output):
 - For each SCT output, select which events set or clear this output. More than one event can change the output, and each event can change multiple outputs.
3. Define how each event affects the counter:
 - Set the corresponding event bit in the LIMIT register for the event to set an upper limit for the counter.

When a limit event occurs in unidirectional mode, the counter is cleared to zero and begins counting up on the next clock edge.

When a limit event occurs in bidirectional mode, the counter begins to count down from the current value on the next clock edge.
 - Set the corresponding event bit in the HALT register for the event to halt the counter. If the counter is halted, it stops counting and no new events can occur. The counter operation can only be restored by clearing the HALT_L and/or the HALT_H bits in the CTRL register.
 - Set the corresponding event bit in the STOP register for the event to stop the counter. If the counter is stopped, it stops counting. However, an event that is configured as a transition on an input/output can restart the counter.
 - Set the corresponding event bit in the START register for the event to restart the counting. Only events that are defined by an input changing can be used to restart the counter.
4. Define which events contribute to the SCT interrupt:
 - Set the corresponding event bit in the EVEN and the EVFLAG registers to enable the event to contribute to the SCT interrupt.
5. Define whether an event triggers a DMA request.
 - Set the corresponding event bit in the DMAREQ0/1 registers for the event to trigger DMA requests 0 or 1.

28.7.10.1.4 Configure multiple states

1. In the EVSTATEMASK register for each event (up to 16 events, one register per event), select the state or states (up to 31) in which this event is allowed to occur. Each state can be selected for more than one event.

2. Determine how the event affects the system state:

In the EVCTRL registers (up to 16 events, one register per event), set the new state value in the STATEV field for this event. If the event is the highest numbered in the current state, this value is either added to the existing state value or replaces the existing state value, depending on the field STATELD.

Remark: If there are higher numbered events in the current state, this event cannot change the state.

If the STATEV and STATELD values are set to zero, the state does not change.

28.7.10.1.5 Miscellaneous options

- There are a certain (selectable) number of capture registers. Each capture register can be programmed to capture the counter contents when one or more events occur.
- If the counter is in bidirectional mode, the effect of set and clear of an output can be made to depend on whether the counter is counting up or down by writing to the OUTPUTDIRCTRL register.

28.7.10.2 Operate the SCT

1. Configure the SCT (see [Section 28.7.10.1 “Configure the SCT”](#)).
 - a. Configure the counter (see [Section 28.7.10.1.1](#)).
 - b. Configure the match and capture registers (see [Section 28.7.10.1.2](#)).
 - c. Configure the events and event responses (see [Section 28.7.10.1.3](#)).
 - d. Configure multiple states ([Section 28.7.10.1.4](#)).
2. Write to the STATE register to define the initial state. By default the initial state is state 0.
3. To start the SCT, write to the CTRL register:
 - Clear the counters.
 - Clear or set the STOP_L and/or STOP_H bits.

Remark: The counter starts counting once the STOP bit is cleared as well. If the STOP bit is set, the SCT waits instead for an event to occur that is configured to start the counter.
 - For each counter, select unidirectional or bidirectional counting mode (field BIDIR_L and/or BIDIR_H).
 - Select the prescale factor for the counter clock (CTRL register).
 - Clear the HALT_L and/or HALT_H bit. By default, the counters are halted and no events can occur.
4. To stop the counters by software at any time, stop or halt the counter (write to STOP_L and/or STOP_H bits or HALT_L and/or HALT_H bits in the CTRL register).
 - When the counters are stopped, both an event configured to clear the STOP bit or software writing a zero to the STOP bit can start the counter again.

- When the counter are halted, only a software write to clear the HALT bit can start the counter again. No events can occur.
- When the counters are halted, software can set any SCT output HIGH or LOW directly by writing to the OUT register.

The current state can be read at any time by reading the STATE register.

To change the current state by software (that is independently of any event occurring), set the HALT bit and write to the STATE register to change the state value. Writing to the STATE register is only allowed when the counter is halted (the HALT_L and/or HALT_H bits are set) and no events can occur.

28.7.10.3 Configure the SCT without using states

The SCT can be used as standard counter/timer with external capture inputs and match outputs without using the state logic. To operate the SCT without states, configure the SCT as follows:

- Write zero to the STATE register (zero is the default).
- Write zero to the STATELD and STATEV fields in the EVCTRL registers for each event.
- Write 0x1 to the EVSTATEMASK register of each event. Writing 0x1 enables the event.

In effect, the event is allowed to occur in a single state which never changes while the counter is running.

29.1 How to read this chapter

The SCT with dither engine is available on all flash-based LPC18xx parts. The SCT implemented here is identical to the SCT implemented for flashless parts except for the following additions:

- Dither engine and fractional match registers
- Automatic limits
- Holding of match events until a qualifying event occurs
- Event enabling based on count direction

All SCT functions available in the flashless parts are also available in the SCT with dither engine. See [Chapter 28 “LPC18xx State Configurable Timer \(SCT\)”](#) for the following sections which apply to both versions of the SCT with or without the dither engine:

[Section 28.2 “Basic configuration”](#)

[Section 28.4 “General description”](#)

[Section 28.5 “Pin description”](#)

[Section 28.7 “Functional description”](#) for all common SCT features

29.2 Features

- Two 16-bit counters or one 32-bit counter.
- Counters clocked by bus clock or selected input.
- Up counters or up-down counters.
- State variable allows sequencing across multiple counter cycles.
- The following conditions define an event: a counter match condition, an input (or output) condition, a combination of a match and/or and input/output condition in a specified state.
- Events control outputs, interrupts, and DMA requests.
 - Match register 0 can be used as an automatic limit.
 - In bi-directional mode, events can be enabled based on the count direction,
 - Match events can be held until another qualifying event occurs.
- Selected events can limit, halt, start, or stop a counter.
- Supports:
 - 8 inputs
 - 16 outputs
 - 16 match/capture registers
 - 16 events
 - 32 states

- Match register 0 to 5 support a fractional component for the dither engine

29.3 Register description

The register addresses of the State Configurable Timer are shown in [Table 667](#). For most of the SCT registers, the register function depends on the setting of certain other register bits:

1. The UNIFY bit in the CONFIG register determines whether the SCT is used as one 32-bit register (for operation as one 32-bit counter/timer) or as two 16-bit counter/timers named L and H. The setting of the UNIFY bit is reflected in the register map:
 - UNIFY = 1: Only one register is used (for operation as one 32-bit counter/timer).
 - UNIFY = 0: Access the L and H registers by a 32-bit read or write operation or can be read or written to individually (for operation as two 16-bit counter/timers).

Typically, the UNIFY bit is configured by writing to the CONFIG register before any other registers are accessed.
2. The REGMODEn bits in the REGMODE register determine whether each set of Match/Capture registers uses the match or capture functionality:
 - REGMODEn = 0: Registers operate as match and reload registers.
 - REGMODEn = 1: Registers operate as capture and capture control registers.

The register overview includes the alias registers for the Match, Reload, Fractional match, Fractional match reload, Capture, and Capture Control L and H 16-bit registers. See [Section 29.4.2](#).

Table 667. Register overview: State Configurable Timer (base address 0x4000 0000)

Name	Access	Address offset	Description	Reset value	Reference
CONFIG	R/W	0x000	SCT configuration register	0x0000 7E00	Table 668
CTRL	R/W	0x004	SCT control register	0x0004 0004	Table 669
CTRL_L	R/W	0x004	SCT control register low counter 16-bit	0x0004 0004	Table 669
CTRL_H	R/W	0x006	SCT control register high counter 16-bit	0x0004 0004	Table 669
LIMIT	R/W	0x008	SCT limit register	0x0000 0000	Table 670
LIMIT_L	R/W	0x008	SCT limit register low counter 16-bit	0x0000 0000	Table 670
LIMIT_H	R/W	0x00A	SCT limit register high counter 16-bit	0x0000 0000	Table 670
HALT	R/W	0x00C	SCT halt condition register	0x0000 0000	Table 671
HALT_L	R/W	0x00C	SCT halt condition register low counter 16-bit	0x0000 0000	Table 671
HALT_H	R/W	0x00E	SCT halt condition register high counter 16-bit	0x0000 0000	Table 671
STOP	R/W	0x010	SCT stop condition register	0x0000 0000	Table 672
STOP_L	R/W	0x010	SCT stop condition register low counter 16-bit	0x0000 0000	Table 672
STOP_H	R/W	0x012	SCT stop condition register high counter 16-bit	0x0000 0000	Table 672
START	R/W	0x014	SCT start condition register	0x0000 0000	Table 673
START_L	R/W	0x014	SCT start condition register low counter 16-bit	0x0000 0000	Table 673
START_H	R/W	0x016	SCT start condition register high counter 16-bit	0x0000 0000	Table 673
DITHER	R/W	0x018	SCT dither condition register		

Table 667. Register overview: State Configurable Timer (base address 0x4000 0000) ...continued

Name	Access	Address offset	Description	Reset value	Reference
DITHER_L	R/W	0x018	SCT dither condition register low counter 16-bit		
DITHER_H	R/W	0x01A	SCT dither condition register high counter 16-bit		
-	-	0x01C - 0x03C	Reserved	-	-
COUNT	R/W	0x040	SCT counter register	0x0000 0000	Table 675
COUNT_L	R/W	0x040	SCT counter register low counter 16-bit	0x0000 0000	Table 675
COUNT_H	R/W	0x042	SCT counter register high counter 16-bit	0x0000 0000	Table 675
STATE	R/W	0x044	SCT state register	0x0000 0000	Table 676
STATE_L	R/W	0x044	SCT state register low counter 16-bit	0x0000 0000	Table 676
STATE_H	R/W	0x046	SCT state register high counter 16-bit	0x0000 0000	Table 676
INPUT	RO	0x048	SCT input register	0x0000 0000	Table 677
REGMODE	R/W	0x04C	SCT match/capture registers mode register	0x0000 0000	Table 678
REGMODE_L	R/W	0x04C	SCT match/capture registers mode register low counter 16-bit	0x0000 0000	Table 678
REGMODE_H	R/W	0x04E	SCT match/capture registers mode register high counter 16-bit	0x0000 0000	Table 678
OUTPUT	R/W	0x050	SCT output register	0x0000 0000	Table 679
OUTPUTDIRCTRL	R/W	0x054	SCT output counter direction control register	0x0000 0000	Table 680
RES	R/W	0x058	SCT conflict resolution register	0x0000 0000	Table 681
DMAREQ0	R/W	0x05C	SCT DMA request 0 register	0x0000 0000	Table 682
DMAREQ1	R/W	0x060	SCT DMA request 1 register	0x0000 0000	Table 683
-	-	0x064 - 0x0EC	Reserved	-	-
EVEN	R/W	0x0F0	SCT event enable register	0x0000 0000	Table 684
EVFLAG	R/W	0x0F4	SCT event flag register	0x0000 0000	Table 685
CONEN	R/W	0x0F8	SCT conflict enable register	0x0000 0000	Table 686
CONFLAG	R/W	0x0FC	SCT conflict flag register	0x0000 0000	Table 687
MATCH0 to MATCH15	R/W	0x100 to 0x13C	SCT match value register of match channels 0 to 15; REGMOD0 to REGMODE15 = 0	0x0000 0000	Table 687
MATCH0_L to MATCH15_L	R/W	0x100 to 0x13C	SCT match value register of match channels 0 to 15; low counter 16-bit; REGMOD0_L to REGMODE15_L = 0	0x0000 0000	Table 687
MATCH0_H to MATCH15_H	R/W	0x102 to 0x13E	SCT match value register of match channels 0 to 15; high counter 16-bit; REGMOD0_H to REGMODE15_H = 0	0x0000 0000	Table 687
CAP0 to CAP15		0x100 to 0x13C	SCT capture register of capture channel 0 to 15; REGMOD0 to REGMODE15 = 1	0x0000 0000	Table 690
CAP0_L to CAP15_L		0x100 to 0x13C	SCT capture register of capture channel 0 to 15; low counter 16-bit; REGMOD0_L to REGMODE15_L = 1	0x0000 0000	Table 690
CAP0_H to CAP15_H		0x102 to 0x13E	SCT capture register of capture channel 0 to 15; high counter 16-bit; REGMOD0_H to REGMODE15_H = 1	0x0000 0000	Table 690

Table 667. Register overview: State Configurable Timer (base address 0x4000 0000) ...continued

Name	Access	Address offset	Description	Reset value	Reference
FRACMAT0 to 5	R/W	0x140 to 0x154	Fractional match registers 0 to 5 for SCT match value registers 0 to 5.	0x0000 0000	Table 689
FRACMAT0_L to FRACMAT5_L	R/W	0x140 to 0x154	Fractional match registers 0 to 5 for SCT match value registers 0 to 5; low counter 16-bit.	0x0000 0000	Table 689
FRACMAT0_H to FRACMAT5_H	R/W	0x142 to 0x156	Fractional match registers 0 to 5 for SCT match value registers 0 to 5; high counter 16-bit.	0x0000 0000	Table 689
MATCH0_L to MATCH15_L	R/W	0x180 to 0x1A0	MATCH alias register. SCT match value register of match channels 0 to 15; low counter 16-bit; REGMOD0_L to REGMODE15_L = 0	0x0000 0000	Table 687
MATCH0_H to MATCH15_H	R/W	0x1C0 to 0x1E0	MATCH alias register. SCT match value register of match channels 0 to 15; high counter 16-bit; REGMOD0_H to REGMODE15_H = 0	0x0000 0000	Table 687
CAP0_L to CAP15_L		0x180 to 0x1A0	CAP alias register. SCT capture register of capture channel 0 to 15; low counter 16-bit; REGMOD0_L to REGMODE15_L = 1	0x0000 0000	Table 690
CAP0_H to CAP15_H		0x1C0 to 0x1E0	CAP alias register. SCT capture register of capture channel 0 to 15; high counter 16-bit; REGMOD0_H to REGMODE15_H = 1	0x0000 0000	Table 690
FRACMAT0_L to FRACMAT5_L	R/W	0x1A0 to 0x1AA	Fractional match alias registers 0 to 5 for SCT match value registers 0 to 5; low counter 16-bit.	0x0000 0000	Table 689
FRACMAT0_H to FRACMAT5_H	R/W	0x1E0 to 0x1EA	Fractional match alias registers 0 to 5 for SCT match value registers 0 to 5; high counter 16-bit.	0x0000 0000	Table 689
MATCHREL0 to MATCHREL15	R/W	0x200 to 0x23C	SCT match reload value register 0 to 15; REGMOD0 = 0 to REGMODE15 = 0	0x0000 0000	Table 691
MATCHREL0_L to MATCHREL15_L	R/W	0x200 to 0x23C	SCT match reload value register 0 to 15; low counter 16-bit; REGMOD0_L = 0 to REGMODE15_L = 0	0x0000 0000	Table 691
MATCHREL0_H to MATCHREL15_H	R/W	0x202 to 0x23E	SCT match reload value register 0 to 15; high counter 16-bit; REGMOD0_H = 0 to REGMODE15_H = 0	0x0000 0000	Table 691
CAPCTRL0 to CAPCTRL15		0x200 to 0x23C	SCT capture control register 0 to 15; REGMOD0 = 1 to REGMODE15 = 1	0x0000 0000	Table 693
CAPCTRL0_L to CAPCTRL15_L		0x200 to 0x23C	SCT capture control register 0 to 15; low counter 16-bit; REGMOD0_L = 1 to REGMODE15_L = 1	0x0000 0000	Table 693
CAPCTRL0_H to CAPCTRL15_H		0x202 to 0x23E	SCT capture control register 0 to 15; high counter 16-bit; REGMOD0 = 1 to REGMODE15 = 1	0x0000 0000	Table 693
FRACMATREL0 to FRACMATREL5	R/W	0x240 to 0x254	Fractional match reload registers 0 to 5 for SCT match value registers 0 to 5.	0x0000 0000	Table 692
FRACMATREL0_L to FRACMATREL5_L	R/W	0x240 to 0x254	Fractional match reload registers 0 to 5 for SCT match value registers 0 to 5; low counter 16-bit.	0x0000 0000	Table 692
FRACMATREL0_H to FRACMATREL5_H	R/W	0x242 to 0x256	Fractional match reload registers 0 to 5 for SCT match value registers 0 to 5; high counter 16-bit.	0x0000 0000	Table 692
MATCHREL0_L to MATCHREL15_L	R/W	0x280 to 0x2A0	MATCHREL alias registers. SCT match reload value register 0 to 15; low counter 16-bit; REGMOD0_L = 0 to REGMODE15_L = 0	0x0000 0000	Table 691
MATCHREL0_H to MATCHREL15_H	R/W	0x2C0 to 0x2E0	MATCHREL alias registers. SCT match reload value register 0 to 15; high counter 16-bit; REGMOD0_H = 0 to REGMODE15_H = 0	0x0000 0000	Table 691

Table 667. Register overview: State Configurable Timer (base address 0x4000 0000) ...continued

Name	Access	Address offset	Description	Reset value	Reference
CAPCTRL0_L to CAPCTRL15_L		0x280 to 0x2E0	CAPCTRL alias registers. SCT capture control register 0 to 15; low counter 16-bit; REGMOD0_L = 1 to REGMODE15_L = 1	0x0000 0000	Table 693
CAPCTRL0_H to CAPCTRL15_H		0x2C0 to 0x2E0	CAPCTRL alias registers. SCT capture control register 0 to 15; high counter 16-bit; REGMOD0 = 1 to REGMODE15 = 1	0x0000 0000	Table 693
FRACMATREL0_L to FRACMATREL5_L	R/W	0x2A0 to 0x2AA	Fractional match reload alias registers 0 to 5 for SCT match value registers 0 to 5; low counter 16-bit.	0x0000 0000	Table 692
FRACMATREL0_H to FRACMATREL5_H	R/W	0x2E0 to 0x2EA	Fractional match reload alias registers 0 to 5 for SCT match value registers 0 to 5; high counter 16-bit.	0x0000 0000	Table 692
EVSTATEMSK0	R/W	0x300	SCT event state register 0	0x0000 0000	Table 694
EVCTRL0	R/W	0x304	SCT event control register 0	0x0000 0000	Table 695
EVSTATEMSK1	R/W	0x308	SCT event state register 1	0x0000 0000	Table 694
EVCTRL1	R/W	0x30C	SCT event control register 1	0x0000 0000	Table 695
EVSTATEMSK2	R/W	0x310	SCT event state register 2	0x0000 0000	Table 694
EVCTRL2	R/W	0x314	SCT event control register 2	0x0000 0000	Table 695
EVSTATEMSK3	R/W	0x318	SCT event state register 3	0x0000 0000	Table 694
EVCTRL3	R/W	0x31C	SCT event control register 3	0x0000 0000	Table 695
EVSTATEMSK4	R/W	0x320	SCT event state register 4	0x0000 0000	Table 694
EVCTRL4	R/W	0x324	SCT event control register 4	0x0000 0000	Table 695
EVSTATEMSK5	R/W	0x328	SCT event state register 5	0x0000 0000	Table 694
EVCTRL5	R/W	0x32C	SCT event control register 5	0x0000 0000	Table 695
EVSTATEMSK6	R/W	0x330	SCT event state register 6	0x0000 0000	Table 694
EVCTRL6	R/W	0x334	SCT event control register 6	0x0000 0000	Table 695
EVSTATEMSK7	R/W	0x338	SCT event state register 7	0x0000 0000	Table 694
EVCTRL7	R/W	0x33C	SCT event control register 7	0x0000 0000	Table 695
EVSTATEMSK8	R/W	0x340	SCT event state register 8	0x0000 0000	Table 694
EVCTRL8	R/W	0x344	SCT event control register 8	0x0000 0000	Table 695
EVSTATEMSK9	R/W	0x348	SCT event state register 9	0x0000 0000	Table 694
EVCTRL9	R/W	0x34C	SCT event control register 9	0x0000 0000	Table 695
EVSTATEMSK10	R/W	0x350	SCT event state register 10	0x0000 0000	Table 694
EVCTRL10	R/W	0x354	SCT event control register 10	0x0000 0000	Table 695
EVSTATEMSK11	R/W	0x358	SCT event state register 11	0x0000 0000	Table 694
EVCTRL11	R/W	0x35C	SCT event control register 11	0x0000 0000	Table 695
EVSTATEMSK12	R/W	0x360	SCT event state register 12	0x0000 0000	Table 694
EVCTRL12	R/W	0x364	SCT event control register 12	0x0000 0000	Table 695
EVSTATEMSK13	R/W	0x368	SCT event state register 13	0x0000 0000	Table 694
EVCTRL13	R/W	0x36C	SCT event control register 13	0x0000 0000	Table 695
EVSTATEMSK14	R/W	0x370	SCT event state register 14	0x0000 0000	Table 694
EVCTRL14	R/W	0x374	SCT event control register 14	0x0000 0000	Table 695

Table 667. Register overview: State Configurable Timer (base address 0x4000 0000) ...continued

Name	Access	Address offset	Description	Reset value	Reference
EVSTATEMSK15	R/W	0x378	SCT event state register 15	0x0000 0000	Table 694
EVCTRL15	R/W	0x37C	SCT event control register 15	0x0000 0000	Table 695
OUTPUTSET0	R/W	0x500	SCT output 0 set register	0x0000 0000	Table 696
OUTPUTCL0	R/W	0x504	SCT output 0 clear register	0x0000 0000	Table 697
OUTPUTSET1	R/W	0x508	SCT output 1 set register	0x0000 0000	Table 696
OUTPUTCL1	R/W	0x50C	SCT output 1 clear register	0x0000 0000	Table 697
OUTPUTSET2	R/W	0x510	SCT output 2 set register	0x0000 0000	Table 696
OUTPUTCL2	R/W	0x514	SCT output 2 clear register	0x0000 0000	Table 697
OUTPUTSET3	R/W	0x518	SCT output 3 set register	0x0000 0000	Table 696
OUTPUTCL3	R/W	0x51C	SCT output 3 clear register	0x0000 0000	Table 697
OUTPUTSET4	R/W	0x520	SCT output 4 set register	0x0000 0000	Table 696
OUTPUTCL4	R/W	0x524	SCT output 4 clear register	0x0000 0000	Table 697
OUTPUTSET5	R/W	0x528	SCT output 5 set register	0x0000 0000	Table 696
OUTPUTCL5	R/W	0x52C	SCT output 5 clear register	0x0000 0000	Table 697
OUTPUTSET6	R/W	0x530	SCT output 6 set register	0x0000 0000	Table 696
OUTPUTCL6	R/W	0x534	SCT output 6 clear register	0x0000 0000	Table 697
OUTPUTSET7	R/W	0x538	SCT output 7 set register	0x0000 0000	Table 696
OUTPUTCL7	R/W	0x53C	SCT output 7 clear register	0x0000 0000	Table 697
OUTPUTSET8	R/W	0x540	SCT output 8 set register	0x0000 0000	Table 696
OUTPUTCL8	R/W	0x544	SCT output 8 clear register	0x0000 0000	Table 697
OUTPUTSET9	R/W	0x548	SCT output 9 set register	0x0000 0000	Table 696
OUTPUTCL9	R/W	0x54C	SCT output 9 clear register	0x0000 0000	Table 697
OUTPUTSET10	R/W	0x550	SCT output 10 set register	0x0000 0000	Table 696
OUTPUTCL10	R/W	0x554	SCT output 10 clear register	0x0000 0000	Table 697
OUTPUTSET11	R/W	0x558	SCT output 11 set register	0x0000 0000	Table 696
OUTPUTCL11	R/W	0x55C	SCT output 11 clear register	0x0000 0000	Table 697
OUTPUTSET12	R/W	0x560	SCT output 12 set register	0x0000 0000	Table 696
OUTPUTCL12	R/W	0x564	SCT output 12 clear register	0x0000 0000	Table 697
OUTPUTSET13	R/W	0x568	SCT output 13 set register	0x0000 0000	Table 696
OUTPUTCL13	R/W	0x56C	SCT output 13 clear register	0x0000 0000	Table 697
OUTPUTSET14	R/W	0x570	SCT output 14 set register	0x0000 0000	Table 696
OUTPUTCL14	R/W	0x574	SCT output 14 clear register	0x0000 0000	Table 697
OUTPUTSET15	R/W	0x578	SCT output 15 set register	0x0000 0000	Table 696
OUTPUTCL15	R/W	0x57C	SCT output 15 clear register	0x0000 0000	Table 697

29.3.1 SCT configuration register

This register configures the overall operation of the SCT. Write to this register before any other registers.

Table 668. SCT configuration register (CONFIG - address 0x4000 0000) bit description

Bit	Symbol	Value	Description	Reset value
0	UNIFY		SCT operation	0
		0	The SCT operates as two 16-bit counters named L and H.	
		1	The SCT operates as a unified 32-bit counter.	
2:1	CLKMODE		SCT clock mode	00
		0x0	The bus clock clocks the SCT and prescalers.	
		0x1	The SCT clock is the bus clock, but the prescalers are enabled to count only when sampling of the input selected by the CKSEL field finds the selected edge. The minimum pulse width on the clock input is 1 bus clock period. This mode is the high-performance sampled-clock mode.	
		0x2	The input selected by CKSEL clocks the SCT and prescalers. The input is synchronized to the bus clock and possibly inverted. The minimum pulse width on the clock input is 1 bus clock period. This mode is the low-power sampled-clock mode.	
		0x3	Reserved.	
6:3	CLKSEL		SCT clock select	0000
		0x0	Rising edges on input 0.	
		0x1	Falling edges on input 0.	
		0x2	Rising edges on input 1.	
		0x3	Falling edges on input 1.	
		0x4	Rising edges on input 2.	
		0x5	Falling edges on input 2.	
		0x6	Rising edges on input 3.	
		0x7	Falling edges on input 3.	
		0x8	Rising edges on input 4.	
		0x9	Falling edges on input 4.	
		0xA	Rising edges on input 5.	
		0xB	Falling edges on input 5.	
		0xC	Rising edges on input 6.	
		0xD	Falling edges on input 6.	
0xE	Rising edges on input 7.			
0xF	Falling edges on input 7.			
7	NORELAOD_L	-	A 1 in this bit prevents the lower match and fractional match registers from being reloaded from their respective reload registers. Software can write to set or clear this bit at any time. This bit applies to both the higher and lower registers when the UNIFY bit is set.	0
8	NORELOAD_H	-	A 1 in this bit prevents the higher match and fractional match registers from being reloaded from their respective reload registers. Software can write to set or clear this bit at any time. This bit is not used when the UNIFY bit is set.	0
16:9	INSYNC	-	Synchronization for input n (bit 9 = input 0, bit 10 = input 1,..., bit 16 = input 7). A 1 in one of these bits subjects the corresponding input to synchronization to the SCT clock, before it is used to create an event. If an input is synchronous to the SCT clock, keep its bit 0 for faster response. When the CKMODE field is 1x, the bit in this field, corresponding to the input selected by the CKSEL field, is not used.	1

Table 668. SCT configuration register (CONFIG - address 0x4000 0000) bit description ...continued

Bit	Symbol	Value	Description	Reset value
17	AUTOLIMIT_L	-	A one in this bit causes a match on match register 0 to be treated as a de-facto LIMIT condition without the need to define an associated event. As with any LIMIT event, this automatic limit causes the counter to be cleared to zero in uni-directional mode or to change the direction of count in bi-directional mode. Software can write to set or clear this bit at any time. This bit applies to both the higher and lower registers when the UNIFY bit is set.	0
18	AUTOLIMIT_H	-	A one in this bit will cause a match on match register 0 to be treated as a de-facto LIMIT condition without the need to define an associated event. As with any LIMIT event, this automatic limit causes the counter to be cleared to zero in uni-directional mode or to change the direction of count in bi-directional mode. Software can write to set or clear this bit at any time. This bit is not used when the UNIFY bit is set.	0
31:19	-	-	Reserved	-

29.3.2 SCT control register

If UNIFY = 1 in the CONFIG register, only the _L bits are used.

If UNIFY = 0 in the CONFIG register, this register can be written to as two registers CTRL_L and CTRL_H. Both the L and H registers can be read or written individually or in a single 32-bit read or write operation.

All bits in this register can be written to when the counter is stopped or halted. When the counter is running, the only bits that can be written are STOP or HALT. (Other bits can be written in a subsequent write after HALT is set to 1.)

Table 669. SCT control register (CTRL - address 0x4000 0004) bit description

Bit	Symbol	Value	Description	Reset value
0	DOWN_L	-	This bit is 1 when the L or unified counter is counting down. Hardware sets this bit when the counter limit is reached and BIDIR is 1. Hardware clears this bit when the counter reaches 0 or when the counter is counting down and a limit condition occurs.	0
1	STOP_L	-	When this bit is 1 and HALT is 0, the L or unified counter does not run but I/O events related to the counter can occur. If such an event matches the mask in the Start register, this bit is cleared and counting resumes.	0
2	HALT_L	-	When this bit is 1, the L or unified counter does not run and no events can occur. A reset sets this bit. When the HALT_L bit is one, the STOP_L bit is cleared. If you want to remove the halt condition and keep the SCT in the stop condition (not running), then you can change the halt and stop condition with one single write to this register. Remark: Once set, only software can clear this bit to restore counter operation.	1
3	CLRCTR_L	-	Writing a 1 to this bit clears the L or unified counter. This bit always reads as 0.	0
4	BIDIR_L		L or unified counter direction select	0
		0	The counter counts up to its limit condition, then is cleared to zero.	
		1	The counter counts up to its limit, then counts down to a limit condition or to 0.	

Table 669. SCT control register (CTRL - address 0x4000 0004) bit description

Bit	Symbol	Value	Description	Reset value
12:5	PRE_L	-	Specifies the factor by which the SCT clock is prescaled to produce the L or unified counter clock. The counter clock is clocked at the rate of the SCT clock divided by PRE_L+1. Remark: Clear the counter (by writing a 1 to the CLRCTR bit) whenever changing the PRE value.	0
15:13	-	-	Reserved	
16	DOWN_H	-	This bit is 1 when the H counter is counting down. Hardware sets this bit when the counter limit is reached and BIDIR is 1. Hardware clears this bit when the counter reaches 0 or when the counter is counting down and a limit condition occurs.	0
17	STOP_H	-	When this bit is 1 and HALT is 0, the H counter does not run but I/O events related to the counter can occur. If such an event matches the mask in the Start register, this bit is cleared and counting resumes.	0
18	HALT_H	-	When this bit is 1, the H counter does not run and no events can occur. A reset sets this bit. When the HALT_H bit is one, the STOP_H bit is cleared. If you want to remove the halt condition and keep the SCT in the stop condition (not running), then you can change the halt and stop condition with one single write to this register. Remark: Once set, this bit can only be cleared by software to restore counter operation.	1
19	CLRCTR_H	-	Writing a 1 to this bit clears the H counter. This bit always reads as 0.	0
20	BIDIR_H	-	Direction select	0
		0	The H counter counts up to its limit condition, then is cleared to zero.	
		1	The H counter counts up to its limit, then counts down to a limit condition or to 0.	
28:21	PRE_H	-	Specifies the factor by which the SCT clock is prescaled to produce the H counter clock. The counter clock is clocked at the rate of the SCT clock divided by PRELH+1. Remark: Clear the counter (by writing a 1 to the CLRCTR bit) whenever changing the PRE value.	0
31:29	-	-	Reserved	

29.3.3 SCT limit register

If UNIFY = 1 in the CONFIG register, only the _L bits are used.

If UNIFY = 0 in the CONFIG register, this register can be written to as two registers LIMIT_L and LIMIT_H. Both the L and H registers can be read or written individually or in a single 32-bit read or write operation.

The bits in this register set which events act as counter limits. After a counter has reached its limit, the counter is cleared to zero in unidirectional mode or changes its direction of count in bidirectional mode. When the counter reaches all ones, this state is always treated as a limit event, and the counter is cleared in unidirectional mode or, in bidirectional mode, begins counting down on the next clock edge - even if no limit event as defined by the SCT limit register has occurred.

In addition to using this register to specify events that serve as limits, it is also possible to automatically cause a limit condition whenever a match register 0 match occurs. This eliminates the need to define an event for the sole purpose of creating a limit. The AUTOLIMIT_L and AUTOLIMIT_H bits in the configuration register enable/disable this feature (see [Table 668](#)).

Table 670. SCT limit register (LIMIT - address 0x4000 0008) bit description

Bit	Symbol	Description	Reset value
15:0	LIMMSK_L	If bit n is one, event n is used as a counter limit event for the L or unified counter (event 0 = bit 0, event 1 = bit 1, event 15 = bit 15).	0
31:16	LIMMSK_H	If bit n is one, event n is used as a counter limit event for the H counter (event 0 = bit 16, event 1 = bit 17, event 15 = bit 31).	0

29.3.4 SCT halt condition register

If UNIFY = 1 in the CONFIG register, only the _L bits are used.

If UNIFY = 0 in the CONFIG register, this register can be written to as two registers HALT_L and HALT_H. Both the L and H registers can be read or written individually or in a single 32-bit read or write operation.

Remark: Any event halting the counter disables its operation until software clears the HALT bit (or bits) in the CTRL register ([Table 669](#)).

Table 671. SCT halt condition register (HALT - address 0x4000 000C) bit description

Bit	Symbol	Description	Reset value
15:0	HALTMSK_L	If bit n is one, event n sets the HALT_L bit in the CTRL register (event 0 = bit 0, event 1 = bit 1, event 15 = bit 15).	0
31:16	HALTMSK_H	If bit n is one, event n sets the HALT_H bit in the CTRL register (event 0 = bit 16, event 1 = bit 17, event 15 = bit 31).	0

29.3.5 SCT stop condition register

If UNIFY = 1 in the CONFIG register, only the _L bits are used.

If UNIFY = 0 in the CONFIG register, this register can be written to as two registers STOP_L and STOP_H. Both the L and H registers can be read or written individually or in a single 32-bit read or write operation.

Table 672. SCT stop condition register (STOP - address 0x4000 0010) bit description

Bit	Symbol	Description	Reset value
15:0	STOPMSK_L	If bit n is one, event n sets the STOP_L bit in the CTRL register (event 0 = bit 0, event 1 = bit 1, event 15 = bit 15).	0
31:16	STOPMSK_H	If bit n is one, event n sets the STOP_H bit in the CTRL register (event 0 = bit 16, event 1 = bit 17, event 15 = bit 31).	0

29.3.6 SCT start condition register

If UNIFY = 1 in the CONFIG register, only the _L bits are used.

If UNIFY = 0 in the CONFIG register, this register can be written to as two registers START_L and START_H. Both the L and H registers can be read or written individually or in a single 32-bit read or write operation.

The bits in this register select which events, if any, clear the STOP bit in the Control register. (Since no events can occur when HALT is 1, only software can clear the HALT bit by writing the Control register.)

Table 673. SCT start condition register (START - address 0x4000 0014) bit description

Bit	Symbol	Description	Reset value
15:0	STARTMSK_L	If bit n is one, event n clears the STOP_L bit in the CTRL register (event 0 = bit 0, event 1 = bit 1, event 15 = bit 15).	0
31:16	STARTMSK_H	If bit n is one, event n clears the STOP_H bit in the CTRL register (event 0 = bit 16, event 1 = bit 17, event 15 = bit 31).	0

29.3.7 SCT dither condition register

If UNIFY = 1 in the CONFIG register, only the L bits are used.

If UNIFY = 0 in the CONFIG register, this register can be written to as two registers DITHER_L and DITHER_H. Both the L and H registers can be read or written individually or in a single 32-bit read or write operation.

When the Dither Condition register contains all zeroes (the default value), the dither engine advances to the next count in the dither pattern **every time** the SCT counter reaches zero (i.e. at the start of every new SCT counter cycle).

It is possible, using this register, to alter that behavior by qualifying the advancement through the dither pattern with designated events. As with the other condition/mask registers (HALT, STOP, LIMIT, etc.) each bit in this register corresponds to an event.

Setting one or more of the bits in this register to ones will cause the dither engine to advance to the next element in the dither pattern (i.e. increment the 16-state cycle counter) only following SCT counter cycles during which one or more of the designated dither events have occurred.

There is one, global Dither Condition register per 16-bit SCT. This register controls advancement through the dither patterns for all of the match registers associated with that half of the SCT.

For details on the dither engine and the dither pattern, see [Section 29.4.1.1](#).

Table 674. SCT dither condition register (DITHER - address 0x4000 0018) bit description

Bit	Symbol	Description	Reset value
15:0	DITHMSK_L	If bit n is one, the event n causes the dither engine to advance to the next element in the dither pattern at the start of the next counter cycle of the 16-bit low counter or the unified counter (event 0 = bit 0, event 1 = bit 1, event 15 = bit 15). If all bits are set to 0, the dither pattern automatically advances at the start of every new counter cycle.	0
31:16	DITHMSK_H	If bit n is one, the event n causes the dither engine to advance to the next element in the dither pattern at the start of the next counter cycle of the 16-bit high counter (event 0 = bit 0, event 1 = bit 1, event 15 = bit 15). If all bits are set to 0, the dither pattern automatically advances at the start of every new counter cycle.	0

29.3.8 SCT counter register

If UNIFY = 1 in the CONFIG register, the counter is a unified 32-bit register and both the _L and _H bits are used.

If UNIFY = 0 in the CONFIG register, this register can be written to as two registers COUNT_L and COUNT_H. Both the L and H registers can be read or written individually or in a single 32-bit read or write operation. In this case, the L and H registers count independently under the control of the other registers.

Attempting to write a counter while it is running does not affect the counter but produces a bus error. Software can read the counter registers at any time.

Table 675. SCT counter register (COUNT - address 0x4000 0040) bit description

Bit	Symbol	Description	Reset value
15:0	CTR_L	When UNIFY = 0, read or write the 16-bit L counter value. When UNIFY = 1, read or write the lower 16 bits of the 32-bit unified counter.	0
31:16	CTR_H	When UNIFY = 0, read or write the 16-bit H counter value. When UNIFY = 1, read or write the upper 16 bits of the 32-bit unified counter.	0

29.3.9 SCT state register

If UNIFY = 1 in the CONFIG register, only the _L bits are used.

If UNIFY = 0 in the CONFIG register, this register can be written to as two registers STATE_L and STATE_H. Both the L and H registers can be read or written individually or in a single 32-bit read or write operation.

Software can read the state associated with a counter at any time. Writing the state is only allowed when the counter HALT bit is 1; when HALT is 0, a write attempt does not change the state and results in a bus error.

The state variable is the main feature that distinguishes the SCT from other counter/timer/PWM blocks. Events can be made to occur only in certain states. Events, in turn, can perform the following actions:

- set and clear outputs
- limit, stop, and start the counter
- cause interrupts and DMA requests
- modify the state variable

The value of a state variable is completely under the control of the application. If an application does not use states, the value of the state variable remains zero, which is the default value.

A state variable can be used to track and control multiple cycles of the associated counter in any desired operational sequence. The state variable is logically associated with a state machine diagram which represents the SCT configuration. See [Section 29.3.26](#) and [29.3.27](#) for more about the relationship between states and events.

The STATELD/STADEV fields in the event control registers of all defined events set all possible values for the state variable. The change of the state variable during multiple counter cycles reflects how the associated state machine moves from one state to the next.

Table 676. SCT state register (STATE - address 0x4000 0044) bit description

Bit	Symbol	Description	Reset value
4:0	STATE_L	State variable.	0
15:5	-	Reserved.	-
20:16	STATE_H	State variable.	0
31:21	-	Reserved.	-

29.3.10 SCT input register

Software can read the state of the SCT inputs in this read-only register in two slightly different forms. The only situation in which these values are different is if CLKMODE = 2 in the CONFIG register.

Table 677. SCT input register (INPUT - address 0x4000 0048) bit description

Bit	Symbol	Description	Reset value
0	AIN0	Real-time status of input 0.	pin
1	AIN1	Real-time status of input 1.	pin
2	AIN2	Real-time status of input 2.	pin
3	AIN3	Real-time status of input 3.	pin
4	AIN4	Real-time status of input 4.	pin
5	AIN5	Real-time status of input 5.	pin
6	AIN6	Real-time status of input 6.	pin
7	AIN7	Real-time status of input 7.	pin
15:8	-	Reserved.	-
16	SIN0	Input 0 state synchronized to the SCT clock.	-
17	SIN1	Input 1 state synchronized to the SCT clock.	-
18	SIN2	Input 2 state synchronized to the SCT clock.	-

Table 677. SCT input register (INPUT - address 0x4000 0048) bit description

Bit	Symbol	Description	Reset value
19	SIN3	Input 3 state synchronized to the SCT clock.	-
20	SIN4	Input 4 state synchronized to the SCT clock.	-
21	SIN5	Input 5 state synchronized to the SCT clock.	-
22	SIN6	Input 6 state synchronized to the SCT clock.	-
23	SIN7	Input 7 state synchronized to the SCT clock.	-
31:24	-	Reserved	-

29.3.11 SCT match/capture registers mode register

If UNIFY = 1 in the CONFIG register, only the _L bits of this register are used. The L bits control whether each set of match/capture registers operates as unified 32-bit capture/match registers.

If UNIFY = 0 in the CONFIG register, this register can be written to as two registers REGMODE_L and REGMODE_H. Both the L and H registers can be read or written individually or in a single 32-bit read or write operation. The _L bits/registers control the L match/capture registers, and the _H bits/registers control the H match/capture registers.

The SCT contains 16 Match/Capture register pairs. The Register Mode register selects whether each register pair acts as a Match register (see [Section 29.3.20](#)) or as a Capture register (see [Section 29.3.22](#)). Each Match/Capture register has an accompanying register which serves as a Reload register when the register is used as a Match register ([Section 29.3.23](#)) or as a Capture-Control register when the register is used as a capture register ([Section 29.3.25](#)). REGMODE_H is used only when the UNIFY bit is 0.

An alternate addressing mode is available for all of the Match/Capture and Reload/Capture-Control registers, for DMA access to halfword registers when UNIFY=0. This mode is described in [Section 29.4.2](#).

Table 678. SCT match/capture registers mode register (REGMODE - address 0x4000 004C) bit description

Bit	Symbol	Description	Reset value
15:0	REGMOD_L	Each bit controls one pair of match/capture registers (register 0 = bit 0, register 1 = bit 1, ..., register 15 = bit 15). 0 = registers operate as match registers. 1 = registers operate as capture registers.	0
31:16	REGMOD_H	Each bit controls one pair of match/capture registers (register 0 = bit 16, register 1 = bit 17, ..., register 15 = bit 31). 0 = registers operate as match registers. 1 = registers operate as capture registers.	0

29.3.12 SCT output register

The SCT supports 16 outputs, each of which has a corresponding bit in this register. Software can write to any of the output registers when both counters are halted to control the outputs directly. Writing to this register when either counter is stopped or running does not affect the outputs and results in a bus error.

Software can read this register at any time to sense the state of the outputs.

Table 679. SCT output register (OUTPUT - address 0x4000 0050) bit description

Bit	Symbol	Description	Reset value
15:0	OUT	Writing a 1 to bit n makes the corresponding output HIGH. 0 makes the corresponding output LOW (output 0 = bit 0, output 1 = bit 1,..., output 15 = bit 15).	0
31:16	-	Reserved	

29.3.13 SCT bidirectional output control register

This register specifies (for each output) the impact of the counting direction on the meaning of set and clear operations on the output (see [Section 29.3.28](#) and [Section 29.3.29](#)).

Table 680. SCT bidirectional output control register (OUTPUTDIRCTRL - address 0x4000 0054) bit description

Bit	Symbol	Value	Description	Reset value
1:0	SETCLR0		Set/clear operation on output 0. Value 0x3 is reserved. Do not program this value.	0
		0x0	Set and clear do not depend on any counter.	
		0x1	Set and clear are reversed when counter L or the unified counter is counting down.	
		0x2	Set and clear are reversed when counter H is counting down. Do not use if UNIFY = 1.	
3:2	SETCLR1		Set/clear operation on output 1. Value 0x3 is reserved. Do not program this value.	0
		0x0	Set and clear do not depend on any counter.	
		0x1	Set and clear are reversed when counter L or the unified counter is counting down.	
		0x2	Set and clear are reversed when counter H is counting down. Do not use if UNIFY = 1.	
5:4	SETCLR2		Set/clear operation on output 2. Value 0x3 is reserved. Do not program this value.	0
		0x0	Set and clear do not depend on any counter.	
		0x1	Set and clear are reversed when counter L or the unified counter is counting down.	
		0x2	Set and clear are reversed when counter H is counting down. Do not use if UNIFY = 1.	
7:6	SETCLR3		Set/clear operation on output 3. Value 0x3 is reserved. Do not program this value.	0
		0x0	Set and clear do not depend on any counter.	
		0x1	Set and clear are reversed when counter L or the unified counter is counting down.	
		0x2	Set and clear are reversed when counter H is counting down. Do not use if UNIFY = 1.	
9:8	SETCLR4		Set/clear operation on output 4. Value 0x3 is reserved. Do not program this value.	0
		0x0	Set and clear do not depend on any counter.	
		0x1	Set and clear are reversed when counter L or the unified counter is counting down.	
		0x2	Set and clear are reversed when counter H is counting down. Do not use if UNIFY = 1.	
11:10	SETCLR5		Set/clear operation on output 5. Value 0x3 is reserved. Do not program this value.	0
		0x0	Set and clear do not depend on any counter.	
		0x1	Set and clear are reversed when counter L or the unified counter is counting down.	
		0x2	Set and clear are reversed when counter H is counting down. Do not use if UNIFY = 1.	

Table 680. SCT bidirectional output control register (OUTPUTDIRCTRL - address 0x4000 0054) bit description

Bit	Symbol	Value	Description	Reset value
13: 12	SETCLR6		Set/clear operation on output 6. Value 0x3 is reserved. Do not program this value.	0
		0x0	Set and clear do not depend on any counter.	
		0x1	Set and clear are reversed when counter L or the unified counter is counting down.	
		0x2	Set and clear are reversed when counter H is counting down. Do not use if UNIFY = 1.	
15: 14	SETCLR7		Set/clear operation on output 7. Value 0x3 is reserved. Do not program this value.	0
		0x0	Set and clear do not depend on any counter.	
		0x1	Set and clear are reversed when counter L or the unified counter is counting down.	
		0x2	Set and clear are reversed when counter H is counting down. Do not use if UNIFY = 1.	
17: 16	SETCLR8		Set/clear operation on output 8. Value 0x3 is reserved. Do not program this value.	0
		0x0	Set and clear do not depend on any counter.	
		0x1	Set and clear are reversed when counter L or the unified counter is counting down.	
		0x2	Set and clear are reversed when counter H is counting down. Do not use if UNIFY = 1.	
19: 18	SETCLR9		Set/clear operation on output 9. Value 0x3 is reserved. Do not program this value.	0
		0x0	Set and clear do not depend on any counter.	
		0x1	Set and clear are reversed when counter L or the unified counter is counting down.	
		0x2	Set and clear are reversed when counter H is counting down. Do not use if UNIFY = 1.	
21: 20	SETCLR10		Set/clear operation on output 5. Value 0x3 is reserved. Do not program this value.	0
		0x0	Set and clear do not depend on any counter.	
		0x1	Set and clear are reversed when counter L or the unified counter is counting down.	
		0x2	Set and clear are reversed when counter H is counting down. Do not use if UNIFY = 1.	
23: 22	SETCLR11		Set/clear operation on output 11. Value 0x3 is reserved. Do not program this value.	0
		0x0	Set and clear do not depend on any counter.	
		0x1	Set and clear are reversed when counter L or the unified counter is counting down.	
		0x2	Set and clear are reversed when counter H is counting down. Do not use if UNIFY = 1.	
25: 24	SETCLR12		Set/clear operation on output 12. Value 0x3 is reserved. Do not program this value.	0
		0x0	Set and clear do not depend on any counter.	
		0x1	Set and clear are reversed when counter L or the unified counter is counting down.	
		0x2	Set and clear are reversed when counter H is counting down. Do not use if UNIFY = 1.	
27: 26	SETCLR13		Set/clear operation on output 13. Value 0x3 is reserved. Do not program this value.	0
		0x0	Set and clear do not depend on any counter.	
		0x1	Set and clear are reversed when counter L or the unified counter is counting down.	
		0x2	Set and clear are reversed when counter H is counting down. Do not use if UNIFY = 1.	
29: 28	SETCLR14		Set/clear operation on output 14. Value 0x3 is reserved. Do not program this value.	0
		0x0	Set and clear do not depend on any counter.	
		0x1	Set and clear are reversed when counter L or the unified counter is counting down.	
		0x2	Set and clear are reversed when counter H is counting down. Do not use if UNIFY = 1.	
31: 30	SETCLR15		Set/clear operation on output 15. Value 0x3 is reserved. Do not program this value.	0
		0x0	Set and clear do not depend on any counter.	
		0x1	Set and clear are reversed when counter L or the unified counter is counting down.	
		0x2	Set and clear are reversed when counter H is counting down. Do not use if UNIFY = 1.	

29.3.14 SCT conflict resolution register

The registers OUTPUTSETn (Section 29.3.28) and OUTPUTCLn (Section 29.3.29) allow both setting and clearing to be indicated for an output in the same clock cycle, even for the same event. This SCT conflict resolution register resolves this conflict.

To enable an event to toggle an output, set the OnRES value to 0x3 in this register, and set the event bits in both the Set and Clear registers.

Table 681. SCT conflict resolution register (RES - address 0x4000 0058) bit description

Bit	Symbol	Value	Description	Reset value
1:0	O0RES		Effect of simultaneous set and clear on output 0.	0
		0x0	No change.	
		0x1	Set output (or clear based on the SETCLR0 field).	
		0x2	Clear output (or set based on the SETCLR0 field).	
		0x3	Toggle output.	
3:2	O1RES		Effect of simultaneous set and clear on output 1.	0
		0x0	No change.	
		0x1	Set output (or clear based on the SETCLR1 field).	
		0x2	Clear output (or set based on the SETCLR1 field).	
		0x3	Toggle output.	
5:4	O2RES		Effect of simultaneous set and clear on output 2.	0
		0x0	No change.	
		0x1	Set output (or clear based on the SETCLR2 field).	
		0x2	Clear output n (or set based on the SETCLR2 field).	
		0x3	Toggle output.	
7:6	O3RES		Effect of simultaneous set and clear on output 3.	0
		0x0	No change.	
		0x1	Set output (or clear based on the SETCLR3 field).	
		0x2	Clear output (or set based on the SETCLR3 field).	
		0x3	Toggle output.	
9:8	O4RES		Effect of simultaneous set and clear on output 4.	0
		0x0	No change.	
		0x1	Set output (or clear based on the SETCLR4 field).	
		0x2	Clear output (or set based on the SETCLR4 field).	
		0x3	Toggle output.	
11:10	O5RES		Effect of simultaneous set and clear on output 5.	0
		0x0	No change.	
		0x1	Set output (or clear based on the SETCLR5 field).	
		0x2	Clear output (or set based on the SETCLR5 field).	
		0x3	Toggle output.	

Table 681. SCT conflict resolution register (RES - address 0x4000 0058) bit description

Bit	Symbol	Value	Description	Reset value
13: 12	O6RES		Effect of simultaneous set and clear on output 6.	0
		0x0	No change.	
		0x1	Set output (or clear based on the SETCLR6 field).	
		0x2	Clear output (or set based on the SETCLR6 field).	
		0x3	Toggle output.	
15: 14	O7RES		Effect of simultaneous set and clear on output 7.	0
		0x0	No change.	
		0x1	Set output (or clear based on the SETCLR7 field).	
		0x2	Clear output (or set based on the SETCLR7 field).	
		0x3	Toggle output.	
17: 16	O8RES		Effect of simultaneous set and clear on output 8.	0
		0x0	No change.	
		0x1	Set output (or clear based on the SETCLR8 field).	
		0x2	Clear output (or set based on the SETCLR8 field).	
		0x3	Toggle output.	
19: 18	O9RES		Effect of simultaneous set and clear on output 9.	0
		0x0	No change.	
		0x1	Set output (or clear based on the SETCLR9 field).	
		0x2	Clear output (or set based on the SETCLR9 field).	
		0x3	Toggle output.	
21: 20	O10RES		Effect of simultaneous set and clear on output 10.	0
		0x0	No change.	
		0x1	Set output (or clear based on the SETCLR10 field).	
		0x2	Clear output (or set based on the SETCLR10 field).	
		0x3	Toggle output.	
23: 22	O11RES		Effect of simultaneous set and clear on output 11.	0
		0x0	No change.	
		0x1	Set output (or clear based on the SETCLR11 field).	
		0x2	Clear output (or set based on the SETCLR11 field).	
		0x3	Toggle output.	
25: 24	O12RES		Effect of simultaneous set and clear on output 12.	0
		0x0	No change.	
		0x1	Set output (or clear based on the SETCLR12 field).	
		0x2	Clear output (or set based on the SETCLR12 field).	
		0x3	Toggle output.	
27: 26	O13RES		Effect of simultaneous set and clear on output 13.	0
		0x0	No change.	
		0x1	Set output (or clear based on the SETCLR13 field).	
		0x2	Clear output (or set based on the SETCLR13 field).	
		0x3	Toggle output.	

Table 681. SCT conflict resolution register (RES - address 0x4000 0058) bit description

Bit	Symbol	Value	Description	Reset value
29: 28	O14RES		Effect of simultaneous set and clear on output 14.	0
		0x0	No change.	
		0x1	Set output (or clear based on the SETCLR14 field).	
		0x2	Clear output (or set based on the SETCLR14 field).	
		0x3	Toggle output.	
31: 30	O15RES		Effect of simultaneous set and clear on output 15.	0
		0x0	No change.	
		0x1	Set output (or clear based on the SETCLR15 field).	
		0x2	Clear output (or set based on the SETCLR15 field).	
		0x3	Toggle output.	

29.3.15 SCT DMA request 0 and 1 registers

The SCT includes two DMA request outputs. These registers enable the DMA requests to be triggered when a particular event occurs or when counter Match registers are loaded from its Reload registers.

Table 682. SCT DMA 0 request register (DMAREQ0 - address 0x4000 005C) bit description

Bit	Symbol	Description	Reset value
15:0	DEV_0	If bit n is one, event n sets DMA request 0 (event 0 = bit 0, event 1 = bit 1, ..., event 15 = bit 15).	0
29:16	-	Reserved	-
30	DRL0	A 1 in this bit makes the SCT set DMA request 0 when it loads the Match_L/Unified registers from the Reload_L/Unified registers.	
31	DRQ0	This read-only bit indicates the state of DMA Request 0	

Table 683. SCT DMA 1 request register (DMAREQ1 - address 0x4000 0060) bit description

Bit	Symbol	Description	Reset value
15:0	DEV_1	If bit n is one, event n sets DMA request 1 (event 0 = bit 0, event 1 = bit 1, ..., event 15 = bit 15).	0
29:16	-	Reserved	-
30	DRL1	A 1 in this bit makes the SCT set DMA request 1 when it loads the Match L/Unified registers from the Reload L/Unified registers.	
31	DRQ1	This read-only bit indicates the state of DMA Request 1.	

29.3.16 SCT flag enable register

This register enables flags to request an interrupt if the FLAGn bit in the SCT event flag register ([Section 29.3.17](#)) is also set.

Table 684. SCT flag enable register (EVEN - address 0x4000 00F0) bit description

Bit	Symbol	Description	Reset value
15:0	IEN	The SCT requests interrupt when bit n of this register and the event flag register are both one (event 0 = bit 0, event 1 = bit 1,..., event 15 = bit 15).	0
31:16	-	Reserved	

29.3.17 SCT event flag register

This register records events. Writing ones to this register clears the corresponding flags and negates the SCT interrupt request if all enabled Flag bits are zero.

Table 685. SCT event flag register (EVFLAG - address 0x4000 00F4) bit description

Bit	Symbol	Description	Reset value
15:0	FLAG	Bit n is one if event n has occurred since reset or a 1 was last written to this bit (event 0 = bit 0, event 1 = bit 1,..., event 15 = bit 15).	0
31:16	-	Reserved	-

29.3.18 SCT conflict enable register

This register enables the “no change conflict” events specified in the SCT conflict resolution register to request an interrupt.

Table 686. SCT conflict enable register (CONEN - address 0x4000 00F8) bit description

Bit	Symbol	Description	Reset value
15:0	NCEN	The SCT requests interrupt when bit n of this register and the SCT conflict flag register are both one (output 0 = bit 0, output 1 = bit 1,..., output 15 = bit 15).	0
31:16	-	Reserved	

29.3.19 SCT conflict flag register

This register records interrupt-enabled no-change conflict events and provides details of a bus error. Writing ones to the NCFLAG bits clears the corresponding read bits and negates the SCT interrupt request if all enabled Flag bits are zero.

Table 687. SCT conflict flag register (CONFLAG - address 0x4000 00FC) bit description

Bit	Symbol	Description	Reset value
15:0	NCFLAG	Bit n is one if a no-change conflict event occurred on output n since reset or a 1 was last written to this bit (output 0 = bit 0, output 1 = bit 1,..., output 15 = bit 15).	0

Table 687. SCT conflict flag register (CONFLAG - address 0x4000 00FC) bit description

Bit	Symbol	Description	Reset value
29:16	-	Reserved.	-
30	BUSERRL	The most recent bus error from this SCT involved writing CTR L/Unified, STATE L/Unified, MATCH L/Unified, or the Output register when the L/U counter was not halted. A word write to certain L and H registers can be half successful and half unsuccessful.	0
31	BUSERRH	The most recent bus error from this SCT involved writing CTR H, STATE H, MATCH H, or the Output register when the H counter was not halted.	0

29.3.20 SCT match registers 0 to 15 (REGMODEn bit = 0)

Match registers are compared to the counters to help create events. When the UNIFY bit is 0, the L and H registers are independently compared to the L and H counters. When UNIFY is 1, the L and H registers hold a 32-bit value that is compared to the unified counter. A Match can only occur in a clock in which the counter is running (STOP and HALT are both 0).

Match registers can be read at any time. Writing to a Match register while the associated counter is running does not affect the Match register and results in a bus error. Match events occur in the SCT clock in which the counter is (or would be) incremented to the next value. When a Match event limits its counter as described in [Section 29.3.3](#), the value in the Match register is the last value of the counter before it is cleared to zero (or decremented if BIDIR is 1).

There is no “write-through” from Reload registers to Match registers. Before starting a counter, software can write one value to the Match register used in the first cycle of the counter and a different value to the corresponding Match Reload register used in the second cycle.

Table 688. SCT match registers 0 to 15 (MATCH[0:15] - address 0x4000 0100 (MATCH0) to 0x4000 4013C (MATCH15)) bit description (REGMODEn bit = 0)

Bit	Symbol	Description	Reset value
15:0	MATCHn_L	When UNIFY = 0, read or write the 16-bit value to be compared to the L counter. When UNIFY = 1, read or write the lower 16 bits of the 32-bit value to be compared to the unified counter.	0
31:16	MATCHn_H	When UNIFY = 0, read or write the 16-bit value to be compared to the H counter. When UNIFY = 1, read or write the upper 16 bits of the 32-bit value to be compared to the unified counter.	0

29.3.21 SCT fractional match registers 0 to 5

Fractional Match registers are provided for up to the first six of the match registers. The values programmed in these registers provide higher average resolution over time by applying a dither pattern as described in [Section 29.4.1.1](#). This dither pattern results in delaying recognition of a match for one counter clock for n (0 to 15) out of every 16 counter cycles. The value of n is programmed in these Fractional Match registers.

Fractional Match registers can be read at any time. Writing to a Fractional Match register while the associated counter is running will not affect the register and will result in a bus error.

Each Fractional Match register has a Fractional Match Reload register associated with it. The contents of the reload registers are transferred into the Fractional Match registers at the start of every new SCT counter cycle unless the NORELOAD bit for the appropriate half-counter is set.

The reload registers may be written to at any time, regardless of whether or not the counter is running.

There is no write-through from the Fractional Match Reload registers to the Fractional Match registers. Before starting a counter, software can write one value to the Fractional Match register that will be used in the first cycle or period of operation, and a different value to the corresponding Fractional Match Reload register that will be used in the second cycle or period.

An alternate addressing mode is available for all of the Fractional Match registers for DMA access to halfword registers when UNIFY=0. See [Section 29.4.2](#).

Table 689. SCT fractional match registers 0 to 5 (FRACMAT[0:5] - address 0x4000 0140 (FRACMAT0) to 0x4000 40154 (FRACMAT5)) bit description

Bit	Symbol	Description	Reset value
3:0	FRACMAT_L	When UNIFY = 0, read or write the 4-bit value specifying the dither pattern to be applied to the corresponding MATCHn_L register (n = 0 to 5). When UNIFY = 1, the value applies to the unified, 32-bit fractional match register.	0
15:4	-	Reserved.	-
19:16	FRACMAT_H	When UNIFY = 0, read or write 4-bit value specifying the dither pattern to be applied to the corresponding MATCHn_H register (n = 0 to 5).	0
31:20	-	Reserved.	-

[1] See [Section 29.4.1.1](#) for selecting the dither pattern.

29.3.22 SCT capture registers 0 to 15 (REGMODEn bit = 1)

These registers allow software to read the counter values at which the event selected by the corresponding Capture Control registers occurred.

Table 690. SCT capture registers 0 to 15 (CAP[0:15] - address 0x4000 0100 (CAP0) to 0x4000 013C (CAP15)) bit description (REGMODEn bit = 1)

Bit	Symbol	Description	Reset value
15:0	CAPn_L	When UNIFY = 0, read the 16-bit counter value at which this register was last captured. When UNIFY = 1, read the lower 16 bits of the 32-bit value at which this register was last captured.	0
31:16	CAPn_H	When UNIFY = 0, read the 16-bit counter value at which this register was last captured. When UNIFY = 1, read the upper 16 bits of the 32-bit value at which this register was last captured.	0

29.3.23 SCT match reload registers 0 to 15 (REGMODEn bit = 0)

A Match register (L, H, or unified 32-bit) is loaded from the corresponding Reload register when BIDIR is 0 and the counter reaches its limit condition, or when BIDIR is 1 and the counter reaches 0.

Table 691. SCT match reload registers 0 to 15 (MATCHREL[0:15] - address 0x4000 0200 (MATCHREL0) to 0x4000 023C (MATCHREL15) bit description (REGMODEn bit = 0)

Bit	Symbol	Description	Reset value
15:0	RELOADn_L	When UNIFY = 0, read or write the 16-bit value to be loaded into the MATCHn_L register. When UNIFY = 1, read or write the lower 16 bits of the 32-bit value to be loaded into the MATCHn register.	0
31:16	RELOADn_H	When UNIFY = 0, read or write the 16-bit to be loaded into the MATCHn_H register. When UNIFY = 1, read or write the upper 16 bits of the 32-bit value to be loaded into the MATCHn register.	0

29.3.24 SCT fractional match reload registers 0 to 5

A Fractional Match register (L, H, or unified 32-bit) is loaded from the corresponding Fractional Match Reload register when BIDIR is 0 and the counter reaches its limit condition, or BIDIR is 1 and the counter reaches 0, unless the appropriate NORELOAD bit is set.

An alternate addressing mode is available for all Fractional Match Reload registers for DMA access to halfword registers when UNIFY=0. See [Section 29.4.2](#).

Table 692. SCT fractional match reload registers 0 to 5 (FRACMATREL[0:5] - address 0x4000 0240 (FRACMATREL0) to 0x4000 0254 (FRACMATREL5) bit description

Bit	Symbol	Description	Reset value
3:0	RELFRACT_L	When UNIFY = 0, read or write the 4-bit value to be loaded into the FRACMATn_L register. When UNIFY = 1, read or write the lower 4 bits to be loaded into the FRACMATn register.	0
15:4	-	Reserved.	-
19:16	RELFRACT_H	When UNIFY = 0, read or write the 4-bit value to be loaded into the FRACMATn_H register. When UNIFY = 1, read or write the upper 4 bits with the 4-bit value to be loaded into the FRACMATn register.	0
31:20	-	Reserved.	-

29.3.25 SCT capture control registers 0 to 15 (REGMODEn bit = 1)

If UNIFY = 1 in the CONFIG register, only the _L bits are used.

If UNIFY = 0 in the CONFIG register, this register can be written to as two registers CAPCTRLn_L and CAPCTRLn_H. Both the L and H registers can be read or written individually or in a single 32-bit read or write operation.

Each Capture Control register (L, H, or unified 32-bit) controls which events load the corresponding Capture register from the counter.

Table 693. SCT capture control registers 0 to 15 (CAPCTRL[0:15] - address 0x4000 0200 (CAPCTRL0) to 0x4000 023C (CAPCTRL15)) bit description (REGMODEn bit = 1)

Bit	Symbol	Description	Reset value
15:0	CAPCONn_L	If bit m is one, event m causes the CAPn_L (UNIFY = 0) or the CAPn (UNIFY = 1) register to be loaded (event 0 = bit 0, event 1 = bit 1, ..., event 15 = bit 15).	0
31:16	CAPCONn_H	If bit m is one, event m causes the CAPn_H (UNIFY = 0) register to be loaded (event 0 = bit 16, event 1 = bit 17, ..., event 15 = bit 31).	0

29.3.26 SCT event state mask registers 0 to 15

Each event has one associated SCT event state mask register that allows this event to happen in one or more states of the counter selected by the HEVENT bit in the corresponding EVCTRLn register.

An event n is disabled when its EVSTATEMSKn register contains all zeros, since it is masked regardless of the current state.

In simple applications that do not use states, write 0x01 to this register to enable an event. Since the state always remains at its reset value of 0, writing 0x01 effectively permanently state-enables this event.

Table 694. SCT event state mask registers 0 to 15 (EVSTATEMSK[0:15] - addresses 0x4000 0300 (EVSTATEMSK0) to 0x4000 0378 (EVSTATEMSK15)) bit description

Bit	Symbol	Description	Reset value
31:0	STATEMSKn	If bit m is one, event n (n= 0 to 15) happens in state m of the counter selected by the HEVENT bit (m = state number; state 0 = bit 0, state 1= bit 1, ..., state 31 = bit 31).	0

29.3.27 SCT event control registers 0 to 15

This register defines the conditions for event n to occur, other than the state variable which is defined by the state mask register. Most events are associated with a particular counter (high, low, or unified), in which case the event can depend on a match to that register. The other possible ingredient of an event is a selected input or output signal.

When the UNIFY bit is 0, each event is associated with a particular counter by the HEVENT bit in its event control register. An event cannot occur when its related counter is halted nor when the current state is not enabled to cause the event as specified in its event mask register. An event is permanently disabled when its event state mask register contains all zeros.

An enabled event can be programmed to occur based on a selected input or output edge or level and/or based on its counter value matching a selected match register. In BIDR mode, events can also be enabled based on the count direction.

Each event can modify its counter STATE value. If more than one event associated with the same counter occurs in a given clock cycle, only the state change specified for the highest-numbered event among them takes place. Other actions dictated by any simultaneously occurring events all take place.

Table 695. SCT event control register 0 to 15 (EVCTRL - address 0x4000 0304 (EVCTRL0) to 0x4000 037C (EVCTRL15)) bit description

Bit	Symbol	Value	Description	Reset value
3:0	MATCHSEL	-	Selects the Match register associated with this event (if any). A match can occur only when the counter selected by the HEVENT bit is running.	0
4	HEVENT	-	Select L/H counter. Do not set this bit if UNIFY = 1.	0
		0	Selects the L state and the L match register selected by MATCHSEL.	
		1	Selects the H state and the H match register selected by MATCHSEL.	
5	OUTSEL	-	Input/output select	0
		0	Selects the input selected by IOSEL.	
		1	Selects the output selected by IOSEL.	
9:6	IOSEL	-	Selects the input or output signal associated with this event (if any). Do not select an input in this register, if CKMODE is 1x. In this case the clock input is an implicit ingredient of every event.	0
11:10	IOCOND	-	Selects the I/O condition for event n. (The detection of edges on outputs lags the conditions that switch the outputs by one SCT clock). In order to guarantee proper edge/state detection, an input must have a minimum pulse width of at least one SCT clock period .	0
		0x0	LOW	
		0x1	Rise	
		0x2	Fall	
		0x3	HIGH	
13:12	COMBMODE	-	Selects how the specified match and I/O condition are used and combined.	0
		0x0	OR. The event occurs when either the specified match or I/O condition occurs.	
		0x1	MATCH. Uses the specified match only.	
		0x2	IO. Uses the specified I/O condition only.	
		0x3	AND. The event occurs when the specified match and I/O condition occur simultaneously.	
14	STATELD	-	This bit controls how the STATEV value modifies the state selected by HEVENT when this event is the highest-numbered event occurring for that state.	0
		0	STATEV value is added into STATE (the carry-out is ignored).	
		1	STATEV value is loaded into STATE.	
19:15	STATEV	-	This value is loaded into or added to the state selected by HEVENT, depending on STATELD, when this event is the highest-numbered event occurring for that state. If STATELD and STATEV are both zero, there is no change to the STATE value.	0
20	MATCHMEM	-	If this bit is one and the COMBMODE field specifies a match component to the triggering of this event, then a match is considered to be active whenever the counter value is GREATER THAN OR EQUAL TO the value specified in the match register when counting up, LESS THEN OR EQUAL TO the match value when counting down. If this bit is zero, a match is only be active during the cycle when the counter is equal to the match value.	

Table 695. SCT event control register 0 to 15 (EVCTRL - address 0x4000 0304 (EVCTRL0) to 0x4000 037C (EVCTRL15)) bit description

Bit	Symbol	Value	Description	Reset value
22:21	DIRECTION		Direction qualifier for event generation. This field only applies when the counters are operating in BIDIR mode. If BIDIR = 0, the SCT ignores this field. Value 0x3 is reserved.	
		0x0	Direction independent. This event is triggered regardless of the count direction.	
		0x1	Counting up. This event is triggered only during up-counting when BIDIR = 1.	
		0x2	Counting down. This event is triggered only during down-counting when BIDIR = 1.	
31:23	-		Reserved	

29.3.28 SCT output set registers 0 to 15

Each output n has one set register that controls how events affect each output. Whether outputs are set or cleared depends on the setting of the SETCLRn field in the OUTPUTDIRCTRL register.

Table 696. SCT output set register 0 to 15 (OUTPUTSET - address 0x4000 0500 (OUTPUTSET0) to 0x4000 0578 (OUTPUTSET15)) bit description

Bit	Symbol	Description	Reset value
15:0	SET	A 1 in bit m selects event m to set output n (or clear it if SETCLRn = 0 0x1 or 0x2) event 0 = bit 0, event 1 = bit 1, ..., event 15 = bit 15.	0
31:16	-	Reserved	

29.3.29 SCT output clear registers 0 to 15

Each output n has one clear register that controls how events affect each output. Whether outputs are set or cleared depends on the setting of the SETCLRn field in the OUTPUTDIRCTRL register.

Table 697. SCT output clear register 0 to 15 (OUTPUTCL - address 0x4000 0504 (OUTPUTCL0) to 0x4000 057C (OUTPUTCL15)) bit description

Bit	Symbol	Description	Reset value
15:0	CLR	A 1 in bit m selects event m to clear output n (or set it if SETCLRn = 0 0x1 or 0x2) event 0 = bit 0, event 1 = bit 1, ..., event 15 = bit 15.	0
31:16	-	Reserved	

29.4 Functional description

29.4.1 Fractional matches

The first 6 match registers may be configured to have a fractional portion to their match values. Higher average resolution is achievable on the match registers with associated fractional match register by using a dithering mechanism. The dither engine delays the assertion of a match by one counter clock every n (0 to 15) out of 16 counter cycles. The value of n is specified in the 4-bit FRACMAT register associated with each of the first six match registers.

Dithering can be disabled on any of the match registers by loading all zeroes (the default value) into its FRACMAT register.

29.4.1.1 Dithering

At the start of each new SCT counter cycle (i.e. when the counter counts-down to zero in bi-directional mode or is cleared to zero by a limit event), the dither engine determines which matches are to be delayed by one clock during the coming counter cycle. Delaying the match effectively adds 1 to the designated match value when up-counting or subtracts 1 when down-counting, during that particular counter cycle.

For each dither-enabled match register, the value programmed in its associated FRACMAT register specifies how many out of every 16 counter cycles its match is to be delayed. An algorithm applied to the FRACMAT value distributes this number as evenly as possible across the 16 counter cycles. This results in a unique dither pattern for each match register (See [Table 698](#)).

Additional control over the dithering process is provided to the user via a Dither Condition (event-mask) register. Typically, the dither engine advances through the match dither patterns at the start of every new SCT counter cycle. The Dither Condition register allows the user to specify that advancement to the next element in the dither patterns will only occur if one or more designated events occurred during the previous cycle of the counter.

The dither algorithm is designed to spread out the cycles in which the matches are delayed as evenly as possible across the 16 counter cycles. The following table shows the dither pattern that is applied for each value of FRACMAT. A 'D' indicates the counter cycles where a match on the relevant match register is delayed.

Table 698. Dither pattern

FRACMAT	Counter cycle															
	0	1	2	3	4	5	6	7	8	9	10	11	12	13	14	15
0x0	-	-	-	-	-	-	-	-	-	-	-	-	-	-	-	-
0x1	-	-	-	-	-	-	-	-	D	-	-	-	-	-	-	-
0x2	-	-	-	-	D	-	-	-	-	-	-	-	D	-	-	-
0x3	-	-	-	-	D	-	-	-	D	-	-	-	D	-	-	-
0x4	-	-	D	-	-	-	D	-	-	-	D	-	-	-	D	-
0x5	-	-	D	-	-	-	D	-	D	-	D	-	-	-	D	-
0x6	-	-	D	-	D	-	D	-	-	-	D	-	D	-	D	-
0x7	-	-	D	-	D	-	D	-	D	-	D	-	D	-	D	-
0x8	-	D	-	D	-	D	-	D	-	D	-	D	-	D	-	D
0x9	-	D	-	D	-	D	-	D	D	D	-	D	-	D	-	D
0xA	-	D	-	D	D	D	-	D	-	D	-	D	D	D	-	D
0xB	-	D	-	D	D	D	-	D	D	D	-	D	D	D	-	D
0xC	-	D	D	D	-	D	D	D	-	D	D	D	-	D	D	D
0xD	-	D	D	D	-	D	D	D	D	D	D	D	-	D	D	D
0xE	-	D	D	D	D	D	D	D	-	D	D	D	D	D	D	D
0xF	-	D	D	D	D	D	D	D	D	D	D	D	D	D	D	D

29.4.2 Alternate addressing for match/capture registers

The Match, Reload, Fractional match, Fractional match reload, Capture, and Capture Control registers are arranged as consecutive words, with the standard division of each word into two halfwords. When the UNIFY bit is zero, these two halfwords are related to the L and H counters. Software has the option of writing words initially to set up both halves of the SCT simultaneously, or writing halfwords to set up each half separately. Applications can use a DMA controller to write Reload registers or to read Capture registers. However, when UNIFY is 0, the addressing of the halfword registers is not compatible with the requirement of many DMA controllers to use consecutive addresses for sequential address operation. [Table 699](#) shows how the second half of the range occupied by each type of register contains an alternate address map for halfword accesses to the same registers, which is compatible with DMA that use sequential address operation. When UNIFY is 1, perform DMA word accesses using standard offsets.

Table 699. Alternate address map for DMA halfword access

Match register	Capture register	Standard offset	DMA halfword offset
MATCH0_L	CAP0_L	0x100	0x180
MATCH0_H	CAP0_H	0x102	0x1C0
MATCH1_L	CAP1_L	0x104	0x182
MATCH1_H	CAP1_H	0x106	0x1C2
...
MATCHRELO_L	CAPCTRL0_L	0x200	0x280
MATCHRELO_H	CAPCTRL0_H	0x202	0x2C0
MATCHREL1_L	CAPCTRL1_L	0x204	0x282
MATCHREL1_H	CAPCTRL1_H	0x206	0x2C2
...
FRACMAT0_L	-	0x140	0x1A0
FRACMAT0_H	-	0x142	0x1E0
FRACMAT1_L	-	0x144	0x1A2
FRACMAT1_H	-	0x146	0x1E2
...	-
RELFRAC0_L	-	0x240	0x2A0
RELFRAC0_H	-	0x242	0x2E0
RELFRAC1_L	-	0x244	0x2A2
RELFRAC1_H	-	0x246	0x2E2
...	-

29.4.3 SCT Example

[Figure 95](#) shows a simple application of the SCT using two sets of match events (EV0/1 and EV3/4) to set/clear SCT output 0. The timer is automatically reset whenever it reaches the MAT0 match value.

In the initial state 0, match event EV0 sets output 0 to HIGH and match event EV1 clears output 0. The SCT input 0 is monitored: If input 0 is found LOW by the next time the timer is reset (EV2), the state is changed to state 1, and EV3/4 are enabled, which create the

same output but triggered by different match values. If input 0 is found HIGH by the next time the timer is reset, the associated event (EV5) causes the state to change back to state 0 where the events EV0 and EV1 are enabled.

The example uses the following SCT configuration:

- 1 input
- 1 output
- 5 match registers
- 6 events and match 0 used with autolimit function
- 2 states

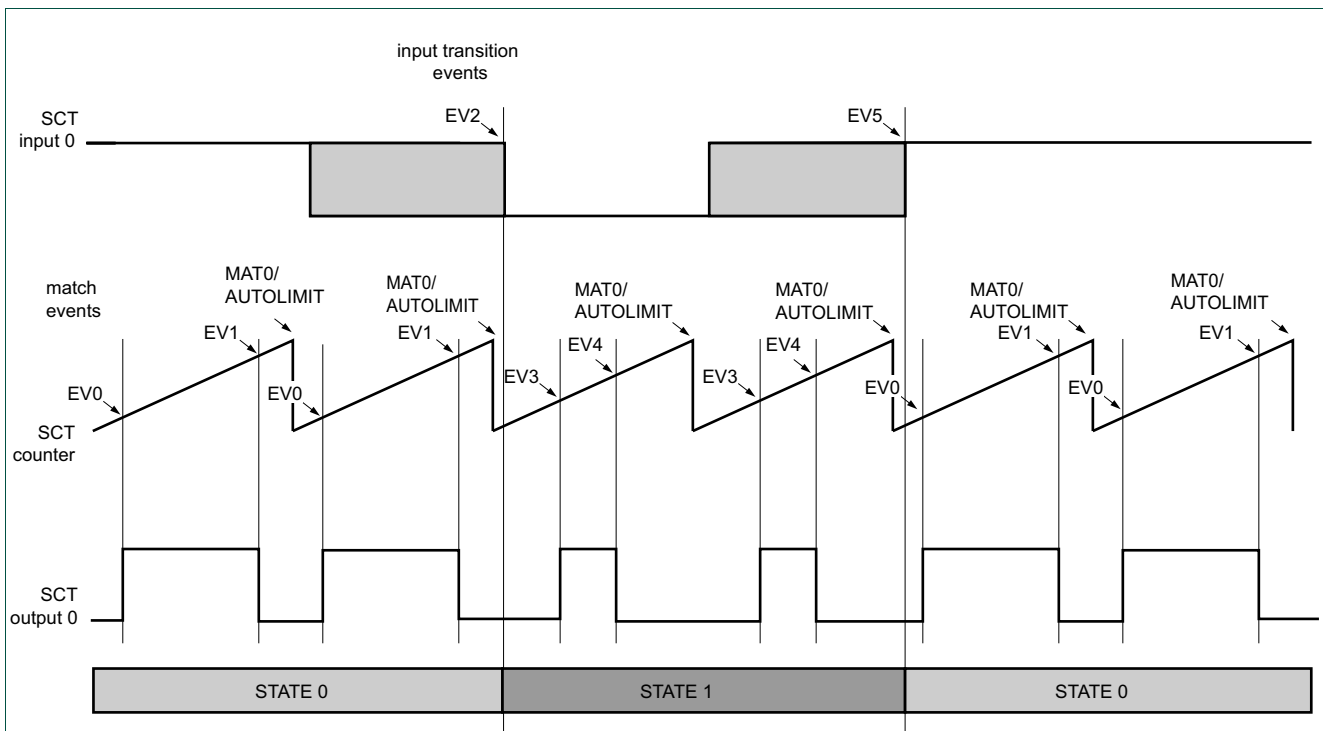

Fig 95. SCT configuration example

This application of the SCT uses the following configuration (all register values not listed in [Table 667](#) are set to their default values):

Table 700. SCT configuration example

Configuration	Registers	Setting
Counter	CONFIG	Uses one counter (UNIFY = 1).
	CONFIG	Enable the autolimit for MAT0. (AUTOLIMIT = 1.)
	CTRL	Uses unidirectional counter (BIDIR_L = 0).
Clock base	CONFIG	Uses default values for clock configuration.
Match/Capture registers	REGMODE	Configure one match register for each match event by setting REGMODE_L bits 0, 1, 2, 3, 4 to 0. This is the default.

Table 700. SCT configuration example

Configuration	Registers	Setting
Define match values	MATCH0/1/2/3/4	Set a match value MATCH0/1/2/3/4_L in each register. The match 0 register serves as an automatic limit event that resets the counter. without using an event. To enable the automatic limit, set the AUTOLIMIT bit in the CONFIG register.
Define match reload values	MATCHRELO/1/2/3/4	Set a match reload value RELOAD0/1/2/3/4_L in each register (same as the match value in this example).
Define when event 0 occurs	EVCTRL0	<ul style="list-style-type: none"> Set COMBMODE = 0x1. Event 0 uses match condition only. Set MATCHSEL = 1. Select match value of match register 1. The match value of MAT1 is associated with event 0.
Define when event 1 occurs	EVCTRL1	<ul style="list-style-type: none"> Set COMBMODE = 0x1. Event 1 uses match condition only. Set MATCHSEL = 2 Select match value of match register 2. The match value of MAT2 is associated with event 1.
Define when event 2 occurs	EVCTRL2	<ul style="list-style-type: none"> Set COMBMODE = 0x3. Event 2 uses match condition and I/O condition. Set IOSEL = 0. Select input 0. Set IOCOND = 0x0. Input 0 is LOW. Set MATCHSEL = 0. Chooses match register 0 to qualify the event.
Define how event 2 changes the state	EVCTRL2	Set STATEV bits to 1 and the STATED bit to 1. Event 2 changes the state to state 1.
Define when event 3 occurs	EVCTRL3	<ul style="list-style-type: none"> Set COMBMODE = 0x1. Event 3 uses match condition only. Set MATCHSEL = 0x3. Select match value of match register 3. The match value of MAT3 is associated with event 3..
Define when event 4 occurs	EVCTRL4	<ul style="list-style-type: none"> Set COMBMODE = 0x1. Event 4 uses match condition only. Set MATCHSEL = 0x4. Select match value of match register 4. The match value of MAT4 is associated with event 4.
Define when event 5 occurs	EVCTRL5	<ul style="list-style-type: none"> Set COMBMODE = 0x3. Event 5 uses match condition and I/O condition. Set IOSEL = 0. Select input 0. Set IOCOND = 0x3. Input 0 is HIGH. Set MATCHSEL = 0. Chooses match register 0 to qualify the event.
Define how event 5 changes the state	EVCTRL5	Set STATEV bits to 0 and the STATED bit to 1. Event 5 changes the state to state 0.
Define by which events output 0 is set	OUTPUTSET0	Set SET0 bits 0 (for event 0) and 3 (for event 3) to one to set the output when these events 0 and 3 occur.
Define by which events output 0 is cleared	OUTPUTCLR0	Set CLR0 bits 1 (for events 1) and 4 (for event 4) to one to clear the output when events 1 and 4 occur.
Configure states in which event 0 is enabled	EVSTATEMSK0	Set STATEMSK0 bit 0 to 1. Set all other bits to 0. Event 0 is enabled in state 0.
Configure states in which event 1 is enabled	EVSTATEMSK1	Set STATEMSK1 bit 0 to 1. Set all other bits to 0. Event 1 is enabled in state 0.
Configure states in which event 2 is enabled	EVSTATEMSK2	Set STATEMSK2 bit 0 to 1. Set all other bits to 0. Event 2 is enabled in state 0.

Table 700. SCT configuration example

Configuration	Registers	Setting
Configure states in which event 3 is enabled	EVSTATEMSK3	Set STATEMSK3 bit 1 to 1. Set all other bits to 0. Event 3 is enabled in state 1.
Configure states in which event 4 is enabled	EVSTATEMSK4	Set STATEMSK4 bit 1 to 1. Set all other bits to 0. Event 4 is enabled in state 1.
Configure states in which event 5 is enabled	EVSTATEMSK5	Set STATEMSK5 bit 1 to 1. Set all other bits to 0. Event 5 is enabled in state 1.

30.1 How to read this chapter

The timers are available on all LPC18xx parts.

30.2 Basic configuration

The Timers are configured as follows:

- See [Table 701](#) for clocking and power control.
- The Timer0/1/2/3 are reset by the TIMER0/1/2/3_RST (reset #32/33/34/35).
- The Timer0/1/2/3 interrupts are connected to slot # 12/13/14/15 in the NVIC. Match channels 2 of Timer0/1/3 are connected to slots # 13, 14, 16 in the Event router. (These outputs are ORed with SCT outputs 2, 6, 14.)
- For connecting the match channels 0 and 1 of Timer0/1/2/3 to the GPDMA, use the DMAMUX register in the CREG block (see [Table 92](#)).
- The timer registers can be accessed by the GPDMA as memory-to-memory transfer.
- To connect a timer capture input to a pin, first select either the CTIN_m or Tn_CAPm input in the SCU ([Section 16.3.11](#)), and then configure the capture input multiplexer for the selected pin through the GIMA (see [Section 17.3](#)).
- The timer match outputs are connected to dedicated Tn_MATm pins and to the CTOUT_m pins, where they may be ORed with the SCT outputs. See [Table 96](#) and [Table 636](#).

Table 701. Timer0/1/2/3 clocking and power control

	Base clock	Branch clock	Operating frequency
Clock to the timer0 register interface and timer0 peripheral clock PCLK.	BASE_M3_CLK	CLK_M3_TIMER0	up to 180 MHz
Clock to the timer1 register interface and timer1 peripheral clock PCLK.	BASE_M3_CLK	CLK_M3_TIMER1	up to 180 MHz
Clock to the timer2 register interface and timer2 peripheral clock PCLK.	BASE_M3_CLK	CLK_M3_TIMER2	up to 180 MHz
Clock to the timer3 register interface and timer3 peripheral clock PCLK.	BASE_M3_CLK	CLK_M3_TIMER3	up to 180 MHz

30.3 Features

- A 32 bit Timer/Counter with a programmable 32 bit Prescaler.
- Counter or Timer operation
- Up to four 32-bit capture channels per timer, that can take a snapshot of the timer value when an input signal transitions. A capture event may also optionally generate an interrupt.
- Four 32-bit match registers that allow:

- Continuous operation with optional interrupt generation on match.
- Stop timer on match with optional interrupt generation.
- Reset timer on match with optional interrupt generation.
- Up to four external outputs corresponding to match registers, with the following capabilities:
 - Set low on match.
 - Set high on match.
 - Toggle on match.
 - Do nothing on match.

30.4 General description

The Timer/Counter is designed to count cycles of the peripheral clock (PCLK) or an externally-supplied clock, and can optionally generate interrupts or perform other actions at specified timer values, based on four match registers. It also includes four capture inputs to trap the timer value when an input signal transitions, optionally generating an interrupt.

[Table 702](#) gives a brief summary of each of the Timer/Counter related functions.

Table 702. Timer/Counter function description

Pin	Type	Description
CAP0_[3:0] CAP1_[3:0] CAP2_[3:0] CAP3_[3:0]	Input	Capture Signals- A transition on a capture input can be configured to load one of the Capture Registers with the value in the Timer Counter and optionally generate an interrupt. Capture functionality can be selected from a number of pins. Timer/Counter block can select a capture signal as a clock source instead of the PCLK derived clock. For more details see Section 30.6.11 .
MAT0_[3:0] MAT1_[3:0] MAT2_[3:0] MAT3_[3:0]	Output	External Match Output - When a match register (MR3:0) equals the timer counter (TC) this output can either toggle, go LOW, go HIGH, or do nothing. The External Match Register (EMR) controls the functionality of this output. Match Output functionality can be selected on a number of pins in parallel.

30.4.1 Architecture

The block diagram for TIMER/COUNTER0 and TIMER/COUNTER1 is shown in [Figure 96](#).

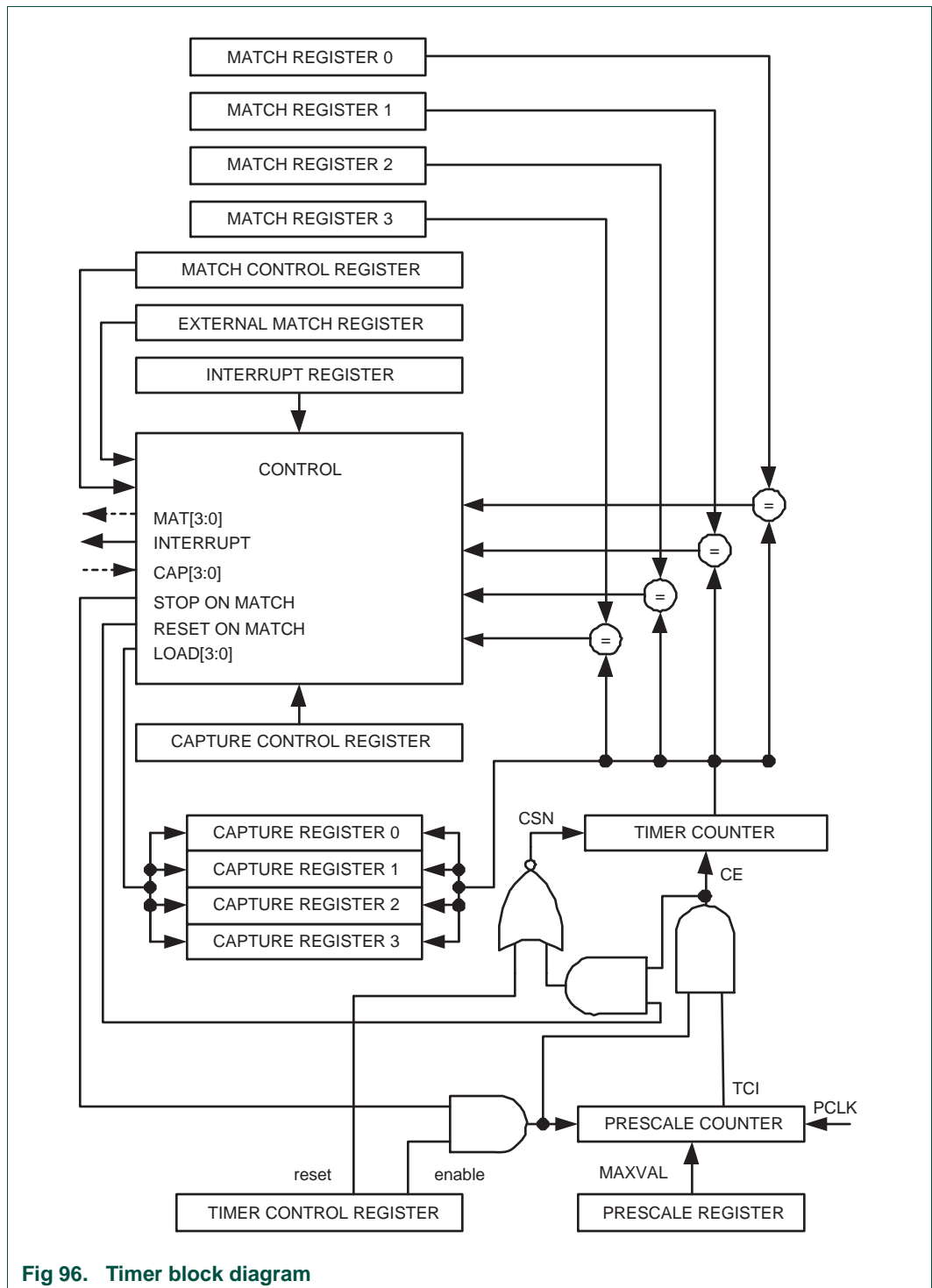

Fig 96. Timer block diagram

30.5 Pin description

Input signals to each timer capture channel can originate from the external pins or from several other internal sources. The GIMA (see [Table 190](#)) and (for capture channel 3 of each timer) the CTOUTCTRL bit of CREG6 determine which signal is captured by the timer.

The match outputs are connected to the Tn_MATm pin functions. In addition, the match outputs ORed with the SCT outputs can be monitored on the CTOUT pins provided that the CTOUTCTRL bit is set to 0 (default) in the CREG6 register (see [Table 96](#)).

Table 703. Timer0 inputs and outputs

Input/output	From/to multiplexed pin function	From/to internal signal	Default (see GIMA, Table 190)	CTOUTCTRL bit (see Table 96)
Timer0 inputs				
CAP0	CTIN_0	-	yes	-
	T0_CAP0	-	no	-
CAP1	CTIN_1	-	yes	-
	T0_CAP1	-	no	-
	-	USART2 TX active	no	-
CAP2	CTIN_2	-	yes	-
	T0_CAP2	-	no	-
CAP3	-	SCT output 15 OR T3 match channel 3	yes	0
	-	SCT output 15	yes	1
	T0_CAP3	-	no	-
	-	T3 match channel 3	no	-
Timer0 outputs				
MAT0	T0_MAT0	-	-	-
	CTOUT_0; if match ORed with SCT output	-	-	0
	-	ADC start0 input (ADC CR register START bits = 0x2)	no	-
MAT1	T0_MAT1	-	no	-
MAT2	T0_MAT2	-	-	-
	CTOUT_2 if match ORed with SCT output	-	-	0
	-	Event router input 13	no	-
MAT3	T0_MAT3	-	-	-
	CTOUT_3 if match ORed with SCT output	-	-	0

Table 704. Timer1 inputs and outputs

Input/output	From/to multiplexed pin function	From/to internal signal	Default (see GIMA, Table 190)	CTOUTCTRL bit (see Table 96)
Timer1 inputs				
CAP0	CTIN_0	-	yes	-
	T1_CAP0	-	no	-
CAP1	CTIN_3	-	yes	-
	T1_CAP1	-	no	-
	-	USART0 TX active	no	-
CAP2	CTIN_4	-	yes	-
	T1_CAP2	-	no	-
CAP3	-	USART0 RX active	no	-
	-	SCT output 3 OR T0 match channel 3	yes	0
	-	SCT output 3	yes	1
	-	T0 match channel 3	no	-
	T1_CAP3	-	no	-
Timer1 outputs				
MAT0	T1_MAT0	-	-	-
MAT1	T1_MAT1	-	-	-
MAT2	T1_MAT2	-	-	-
	-	CTOUT_6 if match ORed with SCT output	-	0
	-	Event router input 14	no	-
MAT3	T1_MAT3	-	-	-
	-	CTOUT_7 if match ORed with SCT output	-	0

Table 705. Timer2 inputs and outputs

Input/output	From/to multiplexed pin function	From/to internal signal	Default (see GIMA, Table 190)	CTOUTCTRL bit (see Table 96)
Timer2 inputs				
CAP0	CTIN_0	-	yes	-
	T2_CAP0	-	no	-
CAP1	CTIN_1	-	yes	-
	T2_CAP1	-	no	-
	-	USART2 TX active	no	-
CAP2	-	I2S1_RX_MWS	no	-
	CTIN_5	-	yes	-

Table 705. Timer2 inputs and outputs ...continued

Input/output	From/to multiplexed pin function	From/to internal signal	Default (see GIMA, Table 190)	CTOUTCTRL bit (see Table 96)
CAP3	T2_CAP2	-	no	-
	-	USART2 RX active	no	-
	-	I2S1_TX_MWS	no	-
	-	SCT output 7 OR T1 match channel 3	yes	0
	-	SCT output 7	yes	1
	-	T1 match channel 3	no	-
	T2_CAP3	-	no	-
Timer2 outputs				
MAT0	T2_MAT0	-	-	-
	CTOUT_8 if match ORed with SCT output	-	-	0
	-	ADC start1 input (ADC CR register bit START = 0x3)	no	-
MAT1	T2_MAT1	-	-	-
MAT2	T2_MAT2	-	-	-
MAT3	T3_MAT3	-	-	-
	CTOUT_11 if match ORed with SCT output	-	-	0

Table 706. Timer3 inputs and outputs

Input/output	From/to multiplexed pin function	From/to internal signal	Default (see GIMA, Table 190)	CTOUTCTRL bit (see Table 96)
Timer3 inputs				
CAP0	CTIN_0	-	yes	-
	-	I2S0_RX_MWS	no	-
	T3_CAP0	-	no	-
CAP1	CTIN_6	-	yes	-
	T3_CAP1	-	no	-
	-	USART3 TX active	no	-
	-	I2S0_TX_MWS	no	-
CAP2	CTIN_7	-	yes	-
	T3_CAP2	-	no	-
	-	USART3 RX active	no	-
	-	SOF0	no	-

Table 706. Timer3 inputs and outputs ...continued

Input/output	From/to multiplexed pin function	From/to internal signal	Default (see GIMA, Table 190)	CTOUTCTRL bit (see Table 96)
CAP3	T3_CAP3		no	-
	-	SCT output 11 OR T2 match channel 3	yes	0
	-	SCT output 11	yes	1
	-	T2 match channel 3	no	-
	-	SOF1	no	-
Timer3 outputs				
MAT0	T3_MAT0	-	-	-
MAT1	T3_MAT1	-	-	-
MAT2	T3_MAT2	-	-	-
	CTOUT_14 if match ORed with SCT output	-	-	0
	-	Event router input 16	no	-
MAT3	T3_MAT3	-	-	-
	CTOUT_1, CTOUT_4, CTOUT_5, CTOUT_9, CTOUT_10, CTOUT_12, CTOUT_13, CTOUT_15 if match ORed with SCT output	-	-	0

30.6 Register description

Each Timer/Counter contains the registers shown in [Table 707](#).

Table 707. Register overview: Timer0/1/2/3 (register base addresses 0x4008 4000 (TIMER0), 0x4008 5000 (TIMER1), 0x400C 3000 (TIMER2), 0x400C 4000 (TIMER3))

Name	Access	Address offset	Description	Reset value ^[1]	Reference value
IR	R/W	0x000	Interrupt Register. The IR can be written to clear interrupts. The IR can be read to identify which of eight possible interrupt sources are pending.	0	Table 708
TCR	R/W	0x004	Timer Control Register. The TCR is used to control the Timer Counter functions. The Timer Counter can be disabled or reset through the TCR.	0	Table 709
TC	R/W	0x008	Timer Counter. The 32 bit TC is incremented every PR+1 cycles of PCLK. The TC is controlled through the TCR.	0	Table 710
PR	R/W	0x00C	Prescale Register. When the Prescale Counter (PC) is equal to this value, the next clock increments the TC and clears the PC.	0	Table 711

Table 707. Register overview: Timer0/1/2/3 (register base addresses 0x4008 4000 (TIMER0), 0x4008 5000 (TIMER1), 0x400C 3000 (TIMER2), 0x400C 4000 (TIMER3))

Name	Access	Address offset	Description	Reset value ^[1]	Reference
PC	R/W	0x010	Prescale Counter. The 32 bit PC is a counter which is incremented to the value stored in PR. When the value in PR is reached, the TC is incremented and the PC is cleared. The PC is observable and controllable through the bus interface.	0	Table 712
MCR	R/W	0x014	Match Control Register. The MCR is used to control if an interrupt is generated and if the TC is reset when a Match occurs.	0	Table 713
MR0	R/W	0x018	Match Register 0. MR0 can be enabled through the MCR to reset the TC, stop both the TC and PC, and/or generate an interrupt every time MR0 matches the TC.	0	Table 714
MR1	R/W	0x01C	Match Register 1. See MR0 description.	0	Table 714
MR2	R/W	0x020	Match Register 2. See MR0 description.	0	Table 714
MR3	R/W	0x024	Match Register 3. See MR0 description.	0	Table 714
CCR	R/W	0x028	Capture Control Register. The CCR controls which edges of the capture inputs are used to load the Capture Registers and whether or not an interrupt is generated when a capture takes place.	0	Table 715
CR0	RO	0x02C	Capture Register 0. CR0 is loaded with the value of TC when there is an event on the CAPn.0 input.	0	Table 716
CR1	RO	0x030	Capture Register 1. See CR0 description.	0	Table 716
CR2	RO	0x034	Capture Register 2. See CR0 description.	0	Table 716
CR3	RO	0x038	Capture Register 3. See CR0 description.	0	Table 716
EMR	R/W	0x03C	External Match Register. The EMR controls the external match pins MATn.0-3 (MAT0.0-3 and MAT1.0-3 respectively).	0	Table 717
CTCR	R/W	0x070	Count Control Register. The CTCR selects between Timer and Counter mode, and in Counter mode selects the signal and edge(s) for counting.	0	Table 719

[1] Reset value reflects the data stored in used bits only. It does not include reserved bits content.

30.6.1 Timer interrupt registers

The Interrupt Register consists of four bits for the match interrupts and four bits for the capture interrupts. If an interrupt is generated then the corresponding bit in the IR will be high. Otherwise, the bit will be low. Writing a logic one to the corresponding IR bit will reset the interrupt. Writing a zero has no effect. The act of clearing an interrupt for a timer match also clears any corresponding DMA request.

Table 708. Timer interrupt registers (IR - addresses 0x4008 4000 (TIMER0), 0x4008 5000 (TIMER1), 0x400C 3000 (TIMER2), 0x400C 4000 (TIMER3)) bit description

Bit	Symbol	Description	Reset value
0	MR0INT	Interrupt flag for match channel 0.	0
1	MR1INT	Interrupt flag for match channel 1.	0
2	MR2INT	Interrupt flag for match channel 2.	0

Table 708. Timer interrupt registers (IR - addresses 0x4008 4000 (TIMER0), 0x4008 5000 (TIMER1), 0x400C 3000 (TIMER2), 0x400C 4000 (TIMER3)) bit description

Bit	Symbol	Description	Reset value
3	MR3INT	Interrupt flag for match channel 3.	0
4	CR0INT	Interrupt flag for capture channel 0 event.	0
5	CR1INT	Interrupt flag for capture channel 1 event.	0
6	CR2INT	Interrupt flag for capture channel 2 event.	0
7	CR3INT	Interrupt flag for capture channel 3 event.	0
31:8	-	Reserved.	-

30.6.2 Timer control registers

The Timer Control Register (TCR) is used to control the operation of the Timer/Counter.

Table 709. Timer control register (TCR - addresses 0x4008 4004 (TIMER0), 0x4008 5004 (TIMER1), 0x400C 3004 (TIMER2), 0x400C 4004 (TIMER3)) bit description

Bit	Symbol	Description	Reset value
0	CEN	When one, the Timer Counter and Prescale Counter are enabled for counting. When zero, the counters are disabled.	0
1	CRST	When one, the Timer Counter and the Prescale Counter are synchronously reset on the next positive edge of PCLK. The counters remain reset until TCR[1] is returned to zero.	0
31:2	-	Reserved, user software should not write ones to reserved bits. The value read from a reserved bit is not defined.	NA

30.6.3 Timer counter registers

The 32-bit Timer Counter register is incremented when the prescale counter reaches its terminal count. Unless it is reset before reaching its upper limit, the Timer Counter will count up through the value 0xFFFF FFFF and then wrap back to the value 0x0000 0000. This event does not cause an interrupt, but a match register can be used to detect an overflow if needed.

Table 710. Timer counter registers (TC - addresses 0x4008 4008 (TIMER0), 0x4008 5008 (TIMER1), 0x400C 3008 (TIMER2), 0x400C 4008 (TIMER3)) bit description

Bit	Symbol	Description	Reset value
31:0	TC	Timer counter value.	0

30.6.4 Timer prescale registers

The 32-bit Timer prescale register specifies the maximum value for the Prescale Counter.

Table 711. Timer prescale registers (PR - addresses 0x4008 400C (TIMER0), 0x4008 500C (TIMER1), 0x400C 300C (TIMER2), 0x400C 400C (TIMER3)) bit description

Bit	Symbol	Description	Reset value
31:0	PM	Prescale counter maximum value.	0

30.6.5 Timer prescale counter registers

The 32-bit Prescale Counter controls division of PCLK by some constant value before it is applied to the Timer Counter. This allows control of the relationship of the resolution of the timer versus the maximum time before the timer overflows. The Prescale Counter is incremented on every PCLK. When it reaches the value stored in the Prescale register, the Timer Counter is incremented and the Prescale Counter is reset on the next PCLK. This causes the Timer Counter to increment on every PCLK when PR = 0, every 2 PCLKs when PR = 1, etc.

Table 712. Timer prescale counter registers (PC - addresses 0x4008 4010 (TIMER0), 0x4008 5010 (TIMER1), 0x400C 3010 (TIMER2), 0x400C 4010 (TIMER3)) bit description

Bit	Symbol	Description	Reset value
31:0	PC	Prescale counter value.	0

30.6.6 Timer match control registers

The Match Control Register is used to control what operations are performed when one of the Match Registers matches the Timer Counter. The function of each of the bits is shown in [Table 713](#).

Table 713. Timer match control registers (MCR - addresses 0x4008 4014 (TIMER0), 0x4008 5014 (TIMER1), 0x400C 3014 (TIMER2), 0x400C 4014 (TIMER3)) bit description

Bit	Symbol	Value	Description	Reset value
0	MR0I		Interrupt on MR0	0
		1	Interrupt is generated when MR0 matches the value in the TC.	
		0	Interrupt is disabled	
1	MR0R		Reset on MR0	0
		1	TC will be reset if MR0 matches it.	
		0	Feature disabled.	
2	MR0S	1	Stop on MR0	0
		1	TC and PC will be stopped and TCR[0] will be set to 0 if MR0 matches the TC.	
		0	Feature disabled.	
3	MR1I		Interrupt on MR1	0
		1	Interrupt is generated when MR1 matches the value in the TC.	
		0	Interrupt is disabled.	

Table 713. Timer match control registers (MCR - addresses 0x4008 4014 (TIMER0), 0x4008 5014 (TIMER1), 0x400C 3014 (TIMER2), 0x400C 4014 (TIMER3)) bit description ...continued

Bit	Symbol	Value	Description	Reset value
4	MR1R		Reset on MR1	0
		1	TC will be reset if MR1 matches it.	
		0	Feature disabled.	
5	MR1S		Stop on MR1	0
		1	TC and PC will be stopped and TCR[0] will be set to 0 if MR1 matches the TC.	
		0	Feature disabled.	
6	MR2I		Interrupt on MR2	0
		1	Interrupt is generated when MR2 matches the value in the TC.	
		0	Interrupt is disabled	
7	MR2R		Reset on MR2	0
		1	TC will be reset if MR2 matches it.	
		0	Feature disabled.	
8	MR2S		Stop on MR2.	0
		1	TC and PC will be stopped and TCR[0] will be set to 0 if MR2 matches the TC	
		0	Feature disabled.	
9	MR3I		Interrupt on MR3	0
		1	Interrupt is generated when MR3 matches the value in the TC.	
		0	This interrupt is disabled	
10	MR3R		Reset on MR3	0
		1	TC will be reset if MR3 matches it.	
		0	Feature disabled.	
11	MR3S		Stop on MR3	0
		1	TC and PC will be stopped and TCR[0] will be set to 0 if MR3 matches the TC.	
		0	Feature disabled.	
31:12	-		Reserved, user software should not write ones to reserved bits. The value read from a reserved bit is not defined.	NA

30.6.7 Timer match registers (MR0 - MR3)

The Match register values are continuously compared to the Timer Counter value. When the two values are equal, actions can be triggered automatically. The action possibilities are to generate an interrupt, reset the Timer Counter, or stop the timer. Actions are controlled by the settings in the MCR register.

Table 714. Timer match registers (MR[0:3], addresses 0x4008 4018 (MR0) to 0x4008 4024 (M3) (TIMER0), 0x4008 5018 (MR0) to 0x4008 5024 (MR3)(TIMER1), 0x400C 3018 (MR0) to 0x400C 8024 (MR3) (TIMER2), 0x400C 4018 (MR0) to 0x400C 4024 (MR3)(TIMER3)) bit description

Bit	Symbol	Description	Reset value
31:0	MATCH	Timer counter match value.	0

30.6.8 Timer capture control registers

The Capture Control Register is used to control whether one of the four Capture Registers is loaded with the value in the Timer Counter when the capture event occurs, and whether an interrupt is generated by the capture event. Setting both the rising and falling bits at the same time is a valid configuration, resulting in a capture event for both edges. In the description below, n represents the Timer number.

Remark: If Counter mode is selected for a particular CAP input in the CTCR, the 3 bits for that input in this register should be programmed as 000, but capture and/or interrupt can be selected for the other 3 CAP inputs.

Table 715. Timer capture control registers (CCR - addresses 0x4008 4028 (TIMER0), 0x4008 5020 (TIMER1), 0x400C 3028 (TIMER2), 0x400C 4028 (TIMER3)) bit description

Bit	Symbol	Value	Description	Reset value
0	CAP0RE		Capture on CAPn.0 rising edge	0
		1	A sequence of 0 then 1 on CAPn.0 will cause CR0 to be loaded with the contents of TC.	
		0	This feature is disabled.	
1	CAP0FE		Capture on CAPn.0 falling edge	0
		1	A sequence of 1 then 0 on CAPn.0 will cause CR0 to be loaded with the contents of TC.	
		0	This feature is disabled.	
2	CAP0I		Interrupt on CAPn.0 event	0
		1	A CR0 load due to a CAPn.0 event will generate an interrupt.	
		0	This feature is disabled.	
3	CAP1RE		Capture on CAPn.1 rising edge	0
		1	A sequence of 0 then 1 on CAPn.1 will cause CR1 to be loaded with the contents of TC.	
		0	This feature is disabled.	
4	CAP1FE		Capture on CAPn.1 falling edge	0
		1	A sequence of 1 then 0 on CAPn.1 will cause CR1 to be loaded with the contents of TC.	
		0	This feature is disabled.	
5	CAP1I		Interrupt on CAPn.1 event	0
		1	A CR1 load due to a CAPn.1 event will generate an interrupt.	
		0	This feature is disabled.	

Table 715. Timer capture control registers (CCR - addresses 0x4008 4028 (TIMER0), 0x4008 5020 (TIMER1), 0x400C 3028 (TIMER2), 0x400C 4028 (TIMER3)) bit description ...continued

Bit	Symbol	Value	Description	Reset value
6	CAP2RE		Capture on CAPn.2 rising edge	0
		1	A sequence of 0 then 1 on CAPn.2 will cause CR2 to be loaded with the contents of TC.	
		0	This feature is disabled.	
7	CAP2FE		Capture on CAPn.2 falling edge:	0
		1	A sequence of 1 then 0 on CAPn.2 will cause CR2 to be loaded with the contents of TC.	
		0	This feature is disabled.	
8	CAP2I		Interrupt on CAPn.2 event	0
		1	A CR2 load due to a CAPn.2 event will generate an interrupt.	
		0	This feature is disabled.	
9	CAP3RE		Capture on CAPn.3 rising edge	0
		1	A sequence of 0 then 1 on CAPn.3 will cause CR3 to be loaded with the contents of TC.	
		0	This feature is disabled.	
10	CAP3FE		Capture on CAPn.3 falling edge	0
		1	A sequence of 1 then 0 on CAPn.3 will cause CR3 to be loaded with the contents of TC.	
		0	This feature is disabled.	
11	CAP3I		Interrupt on CAPn.3 event:	0
		1	A CR3 load due to a CAPn.3 event will generate an interrupt.	
		0	This feature is disabled.	
31:12	-		Reserved, user software should not write ones to reserved bits. The value read from a reserved bit is not defined.	NA

30.6.9 Timer capture registers (CR0 - CR3)

Each Capture register is associated with a device pin and may be loaded with the Timer Counter value when a specified event occurs on that pin. The settings in the Capture Control Register register determine whether the capture function is enabled, and whether a capture event happens on the rising edge of the associated pin, the falling edge, or on both edges.

Table 716. Timer capture registers (CR[0:3], address 0x4008 402C (CR0) to 0x4008 4038 (CR3) (TIMER0), 0x4008 502C (CR0) to 0x4008 5038 (CR3) (TIMER1), 0x400C 302C (CR0) to 0x400C 3038 (CR3) (TIMER2), 0x400C 402C (CR0) to 0x400C 4038 (CR3) (TIMER3)) bit description

Bit	Symbol	Description	Reset value
31:0	CAP	Timer counter capture value.	0

30.6.10 Timer external match registers

The External Match Register provides both control and status of the external match pins. In the descriptions below, “n” represents the Timer number, 0 or 1, and “m” represent a Match number, 0 through 3.

Match events for Match 0 and Match 1 in each timer can cause a DMA request, see [Section 30.7.2](#).

Table 717. Timer external match registers (EMR - addresses 0x4008 403C (TIMER0), 0x4008 503C (TIMER1), 0x400C 303C (TIMER2), 0x400C 403C (TIMER3)) bit description

Bit	Symbol	Value	Description	Reset value
0	EM0		External Match 0. When a match occurs between the TC and MR0, this bit can either toggle, go low, go high, or do nothing, depending on bits 5:4 of this register. This bit can be driven onto a MATn.0 pin, in a positive-logic manner (0 = low, 1 = high).	0
1	EM1		External Match 1. When a match occurs between the TC and MR1, this bit can either toggle, go low, go high, or do nothing, depending on bits 7:6 of this register. This bit can be driven onto a MATn.1 pin, in a positive-logic manner (0 = low, 1 = high).	0
2	EM2		External Match 2. When a match occurs between the TC and MR2, this bit can either toggle, go low, go high, or do nothing, depending on bits 9:8 of this register. This bit can be driven onto a MATn.0 pin, in a positive-logic manner (0 = low, 1 = high).	0
3	EM3		External Match 3. When a match occurs between the TC and MR3, this bit can either toggle, go low, go high, or do nothing, depending on bits 11:10 of this register. This bit can be driven onto a MATn.0 pin, in a positive-logic manner (0 = low, 1 = high).	0
5:4	EMC0		External Match Control 0. Determines the functionality of External Match 0.	00
		0x0	Do Nothing.	
		0x1	Clear the corresponding External Match bit/output to 0 (MATn.m pin is LOW if pinned out).	
		0x2	Set the corresponding External Match bit/output to 1 (MATn.m pin is HIGH if pinned out).	
		0x3	Toggle the corresponding External Match bit/output.	
7:6	EMC1		External Match Control 1. Determines the functionality of External Match 1.	00
		0x0	Do Nothing.	
		0x1	Clear the corresponding External Match bit/output to 0 (MATn.m pin is LOW if pinned out).	
		0x2	Set the corresponding External Match bit/output to 1 (MATn.m pin is HIGH if pinned out).	
		0x3	Toggle the corresponding External Match bit/output.	

Table 717. Timer external match registers (EMR - addresses 0x4008 403C (TIMER0), 0x4008 503C (TIMER1), 0x400C 303C (TIMER2), 0x400C 403C (TIMER3)) bit description

Bit	Symbol	Value	Description	Reset value
9:8	EMC2		External Match Control 2. Determines the functionality of External Match 2.	00
		0x0	Do Nothing.	
		0x1	Clear the corresponding External Match bit/output to 0 (MATn.m pin is LOW if pinned out).	
		0x2	Set the corresponding External Match bit/output to 1 (MATn.m pin is HIGH if pinned out).	
		0x3	Toggle the corresponding External Match bit/output.	
11:10	EMC3		External Match Control 3. Determines the functionality of External Match 3.	00
		0x0	Do Nothing.	
		0x1	Clear the corresponding External Match bit/output to 0 (MATn.m pin is LOW if pinned out).	
		0x2	Set the corresponding External Match bit/output to 1 (MATn.m pin is HIGH if pinned out).	
		0x3	Toggle the corresponding External Match bit/output.	
31:12	-		Reserved, user software should not write ones to reserved bits. The value read from a reserved bit is not defined.	NA

Table 718. External Match Control

EMR[11:10], EMR[9:8], EMR[7:6], or EMR[5:4]	Function
00	Do Nothing.
01	Clear the corresponding External Match bit/output to 0 (MATn.m pin is LOW if pinned out).
10	Set the corresponding External Match bit/output to 1 (MATn.m pin is HIGH if pinned out).
11	Toggle the corresponding External Match bit/output.

30.6.11 Timer count control registers

The Count Control Register (CTCR) is used to select between Timer and Counter mode, and in Counter mode to select the pin and edge(s) for counting.

When Counter Mode is chosen as a mode of operation, the CAP input (selected by the CTCR bits 3:2) is sampled on every rising edge of the PCLK clock. After comparing two consecutive samples of this CAP input, one of the following four events is recognized: rising edge, falling edge, either of edges or no changes in the level of the selected CAP input. Only if the identified event corresponds to the one selected by bits 1:0 in the CTCR register, the Timer Counter register will be incremented.

Effective processing of the externally supplied clock to the counter has some limitations. Since two successive rising edges of the PCLK clock are used to identify only one edge on the CAP selected input, the frequency of the CAP input can not exceed one quarter of the PCLK clock. Consequently, duration of the high/low levels on the same CAP input in this case can not be shorter than $1/(2 \text{ PCLK})$.

Table 719. Timer count control register (CTCR - addresses 0x4008 4070 (TIMER0), 0x4008 5070 (TIMER1), 0x400C 3070 (TIMER2), 0x400C 4070 (TIMER3)) bit description

Bit	Symbol	Value	Description	Reset value
1:0	CTMODE		Counter/Timer Mode This field selects which rising PCLK edges can increment Timer's Prescale Counter (PC), or clear PC and increment Timer Counter (TC). Timer Mode: the TC is incremented when the Prescale Counter matches the Prescale Register.	00
		0x0	Timer Mode: every rising PCLK edge	
		0x1	Counter Mode: TC is incremented on rising edges on the CAP input selected by bits 3:2.	
		0x2	Counter Mode: TC is incremented on falling edges on the CAP input selected by bits 3:2.	
		0x3	Counter Mode: TC is incremented on both edges on the CAP input selected by bits 3:2.	
3:2	CINSEL		Count Input Select When bits 1:0 in this register are not 00, these bits select which CAP pin is sampled for clocking. Note: If Counter mode is selected for a particular CAPn input in the TnCTCR, the 3 bits for that input in the Capture Control Register (TnCCR) must be programmed as 000. However, capture and/or interrupt can be selected for the other 3 CAPn inputs in the same timer.	00
		0x0	CAPn.0 for TIMERN	
		0x1	CAPn.1 for TIMERN	
		0x2	CAPn.2 for TIMERN	
		0x3	CAPn.3 for TIMERN	
31:4	-	-	Reserved, user software should not write ones to reserved bits. The value read from a reserved bit is not defined.	NA

30.7 Functional description

30.7.1 Example timer operation

[Figure 97](#) shows a timer configured to reset the count and generate an interrupt on match. The prescaler is set to 2 and the match register set to 6. At the end of the timer cycle where the match occurs, the timer count is reset. This gives a full length cycle to the match value. The interrupt indicating that a match occurred is generated in the next clock after the timer reached the match value.

Figure 98 shows a timer configured to stop and generate an interrupt on match. The prescaler is again set to 2 and the match register set to 6. In the next clock after the timer reaches the match value, the timer enable bit in TCR is cleared, and the interrupt indicating that a match occurred is generated.

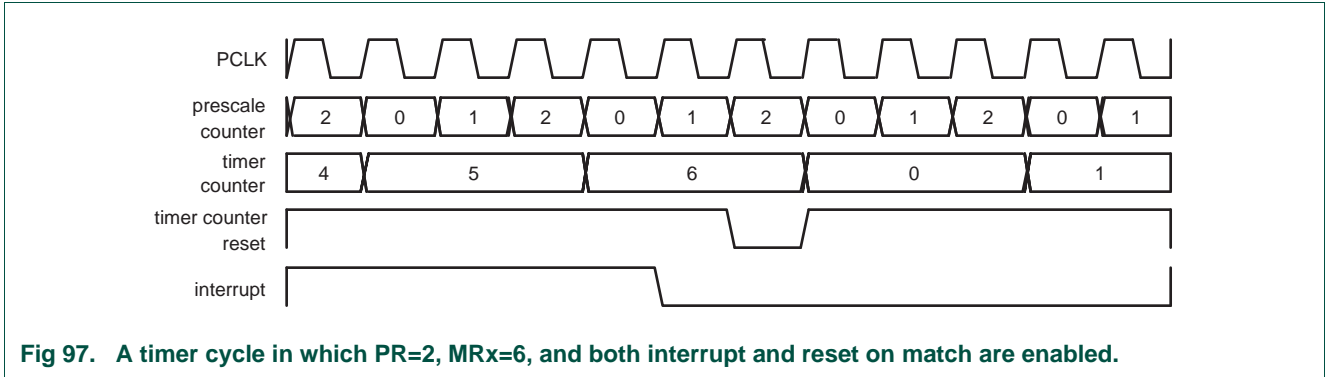

Fig 97. A timer cycle in which PR=2, MRx=6, and both interrupt and reset on match are enabled.

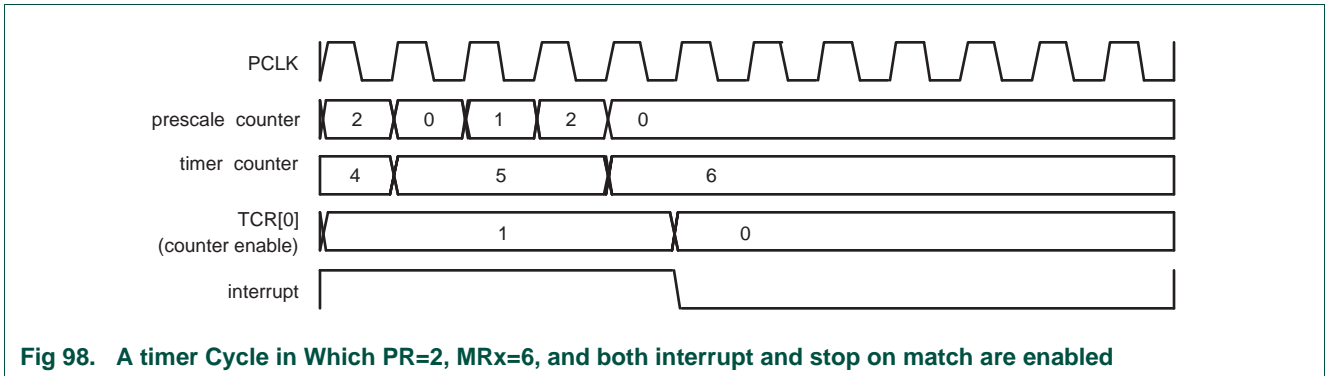

Fig 98. A timer Cycle in Which PR=2, MRx=6, and both interrupt and stop on match are enabled

30.7.2 DMA operation

DMA requests are generated by 0 to 1 transitions of the External Match 0 and 1 bits of each timer. In order to have an effect, the GPDMA must be configured and the relevant timer DMA request selected as a DMA source via the CREG block, see [Table 92](#).

When a timer is initially set up to generate a DMA request, the request may already be asserted before a match condition occurs. An initial DMA request may be avoided by having software by write a one to the interrupt flag location, as if clearing a timer interrupt. See [Section 30.6.1](#). A DMA request will be cleared automatically when it is acted upon by the GPDMA controller.

31.1 How to read this chapter

The Motor control PWM is not available on LPC1810FET100, LPC1820FET100, and LPC1830FET100 parts.

31.2 Basic configuration

The PWM is configured as follows:

- See [Table 720](#) for clocking and power control.
- The PWM is reset by the MOTOCONPWM_RST (reset #38).
- The PWM interrupt is connected to slot # 16 in the NVIC.

Table 720. PWM clocking and power control

	Base clock	Branch clock	Operating frequency
Clock to the PWM Motor control block and PWM peripheral clock.	BASE_APB1_CLK	CLK_APB1_MOTOCON	up to 180 MHz

31.3 Introduction

The Motor Control PWM (MCPWM) is optimized for three-phase AC and DC motor control applications, but can be used in many other applications that need timing, counting, capture, and comparison.

31.4 Features

The MCPWM contains three independent channels, each including:

- a 32-bit Timer/Counter (TC)
- a 32-bit Limit register (LIM)
- a 32-bit Match register (MAT)
- a 10-bit dead-time register (DT) and an associated 10-bit dead-time counter
- a 32-bit capture register (CAP)
- two modulated outputs (MCOA and MCOB) with opposite polarities
- a period interrupt, a pulse-width interrupt, and a capture interrupt

Input pins MCI0-2 can trigger TC capture or increment a channel's TC. A global Abort input can force all of the channels into "A passive" state and cause an interrupt.

31.5 General description

[Section 31.8](#) includes detailed descriptions of the various modes of MCPWM operation, but a quick preview here will provide background for the register descriptions below.

The MCPWM includes 3 channels, each of which controls a pair of outputs that in turn can control something off-chip, like one set of coils in a motor. Each channel includes a Timer/Counter (TC) register that is incremented by a processor clock (timer mode) or by an input pin (counter mode).

Each channel has a Limit register that is compared to the TC value, and when a match occurs the TC is “recycled” in one of two ways. In “edge-aligned mode” the TC is reset to 0, while in “centered mode” a match switches the TC into a state in which it decrements on each processor clock or input pin transition until it reaches 0, at which time it starts counting up again.

Each channel also includes a Match register that holds a smaller value than the Limit register. In edge-aligned mode the channel’s outputs are switched whenever the TC matches either the Match or Limit register, while in center-aligned mode they are switched only when it matches the Match register.

So the Limit register controls the period of the outputs, while the Match register controls how much of each period the outputs spend in each state. Having a small value in the Limit register minimizes “ripple” if the output is integrated into a voltage, and allows the MCPWM to control devices that operate at high speed.

The “downside” of small values in the Limit register is that they reduce the resolution of the duty cycle controlled by the Match register. If you have 8 in the Limit register, the Match register can only select the duty cycle among 0%, 12.5%, 25%, ..., 87.5%, or 100%. In general, the resolution of each step in the Match value is 1 divided by the Limit value.

This trade-off between resolution and period/frequency is inherent in the design of pulse width modulators.

31.5.1 Block Diagram

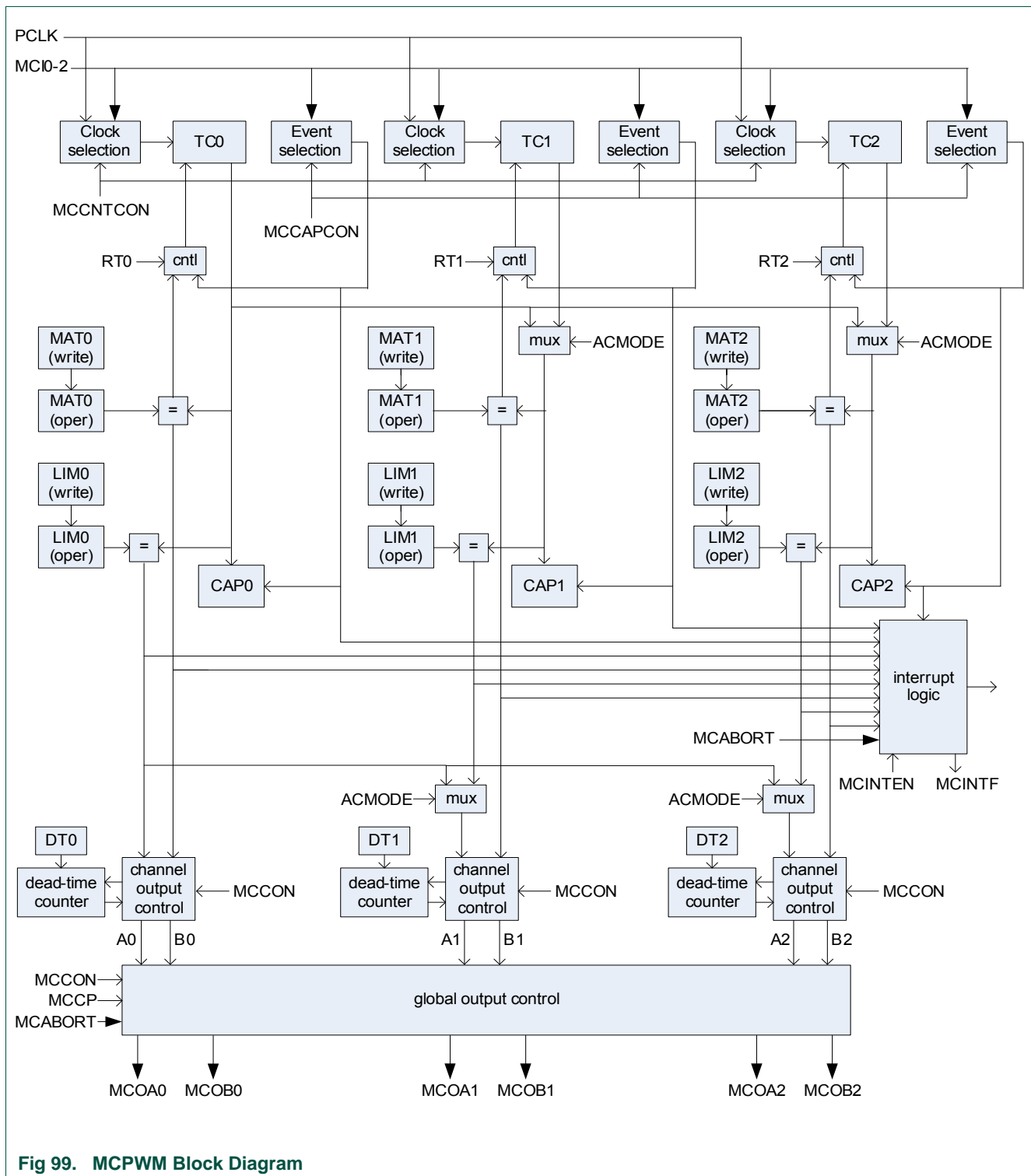

Fig 99. MCPWM Block Diagram

31.6 Pin description

Table 721 lists the MCPWM pins.

Table 721. MOTOCON PWM pin description

Pin function	Type	Description
MCOA0/1/2	O	Output A for channels 0, 1, 2
MCOB0/1/2	O	Output B for channels 0, 1, 2
MCABORT	I	Low-active Fast Abort
MCI0/1/2	I	Input for channels 0, 1, 2

31.7 Register description

“Control” registers and “interrupt” registers have separate read, set, and clear addresses. Reading such a register’s read address (e.g. MCON) yields the state of the register bits. Writing ones to the set address (e.g. MCON_SET) sets register bit(s), and writing ones to the clear address (e.g. MCON_CLR) clears register bit(s).

The Capture registers (MCCAP) are read-only, and the write-only MCCAP_CLR address can be used to clear one or more of them. All the other MCPWM registers (MCTIM, MCPER, MCPW, MCDEADTIME, and M CCP) are normal read-write registers.

Table 722. Register overview: Motor Control Pulse Width Modulator (MCPWM) (base address 0x400A 0000)

Name	Access	Address offset	Description	Reset value	Reference
CON	RO	0x000	PWM Control read address	0	Table 723
CON_SET	WO	0x004	PWM Control set address	-	Table 724
CON_CLR	WO	0x008	PWM Control clear address	-	Table 725
CAPCON	RO	0x00C	Capture Control read address	0	Table 726
CAPCON_SET	WO	0x010	Capture Control set address	-	Table 727
CAPCON_CLR	WO	0x014	Event Control clear address	-	Table 728
TC0	R/W	0x018	Timer Counter register, channel 0	0	Table 729
TC1	R/W	0x01C	Timer Counter register, channel 1	0	Table 729
TC2	R/W	0x020	Timer Counter register, channel 2	0	Table 729
LIM0	R/W	0x024	Limit register, channel 0	0xFFFF FFFF	Table 730
LIM1	R/W	0x028	Limit register, channel 1	0xFFFF FFFF	Table 730
LIM2	R/W	0x02C	Limit register, channel 2	0xFFFF FFFF	Table 730
MAT0	R/W	0x030	Match register, channel 0	0xFFFF FFFF	Table 731
MAT1	R/W	0x034	Match register, channel 1	0xFFFF FFFF	Table 731
MAT2	R/W	0x038	Match register, channel 2	0xFFFF FFFF	Table 731
DT	R/W	0x03C	Dead time register	0x3FFF FFFF	Table 732
MCCP	R/W	0x040	Communication Pattern register	0	Table 733
CAP0	RO	0x044	Capture register, channel 0	0	Table 734
CAP1	RO	0x048	Capture register, channel 1	0	Table 734
CAP2	RO	0x04C	Capture register, channel 2	0	Table 734
INTEN	RO	0x050	Interrupt Enable read address	0	Table 736
INTEN_SET	WO	0x054	Interrupt Enable set address	-	Table 737
INTEN_CLR	WO	0x058	Interrupt Enable clear address	-	Table 738
CNTCON	RO	0x05C	Count Control read address	0	Table 739

Table 722. Register overview: Motor Control Pulse Width Modulator (MCPWM) (base address 0x400A 0000)

Name	Access	Address offset	Description	Reset value	Reference
CNTCON_SET	WO	0x060	Count Control set address	-	Table 740
CNTCON_CLR	WO	0x064	Count Control clear address	-	Table 741
INTF	RO	0x068	Interrupt flags read address	0	Table 742
INTF_SET	WO	0x06C	Interrupt flags set address	-	Table 743
INTF_CLR	WO	0x070	Interrupt flags clear address	-	Table 744
CAP_CLR	WO	0x074	Capture clear address	-	Table 745

31.7.1 MCPWM Control register

31.7.1.1 MCPWM Control read address

The CON register controls the operation of all channels of the PWM. This address is read-only, but the underlying register can be modified by writing to addresses CON_SET and CON_CLR.

Table 723. MCPWM Control read address (CON - 0x400A 0000) bit description

Bit	Symbol	Value	Description	Reset value
0	RUN0		Stops/starts timer channel 0.	0
		0	Stop.	
		1	Run.	
1	CENTER0		Edge/center aligned operation for channel 0.	0
		0	Edge-aligned.	
		1	Center-aligned.	
2	POLA0		Selects polarity of the MCOA0 and MCOB0 pins.	0
		0	Passive state is LOW, active state is HIGH.	
		1	Passive state is HIGH, active state is LOW.	
3	DTE0		Controls the dead-time feature for channel 0.	0
		0	Dead-time disabled.	
		1	Dead-time enabled.	
4	DISUP0		Enable/disable updates of functional registers for channel 0 (see Section 31.8.2).	0
		0	Functional registers are updated from the write registers at the end of each PWM cycle.	
		1	Functional registers remain the same as long as the timer is running.	
7:5	-	-	Reserved.	
8	RUN1		Stops/starts timer channel 1.	0
		0	Stop.	
		1	Run.	
9	CENTER1		Edge/center aligned operation for channel 1.	0
		0	Edge-aligned.	
		1	Center-aligned.	

Table 723. MCPWM Control read address (CON - 0x400A 0000) bit description

Bit	Symbol	Value	Description	Reset value
10	POLA1		Selects polarity of the MCOA1 and MCOB1 pins.	0
		0	Passive state is LOW, active state is HIGH.	
		1	Passive state is HIGH, active state is LOW.	
11	DTE1		Controls the dead-time feature for channel 1.	0
		0	Dead-time disabled.	
		1	Dead-time enabled.	
12	DISUP1		Enable/disable updates of functional registers for channel 1 (see Section 31.8.2).	0
		0	Functional registers are updated from the write registers at the end of each PWM cycle.	
		1	Functional registers remain the same as long as the timer is running.	
15:13	-	-	Reserved.	0
16	RUN2		Stops/starts timer channel 2.	0
		0	Stop.	
		1	Run.	
17	CENTER2		Edge/center aligned operation for channel 2.	0
		0	Edge-aligned.	
		1	Center-aligned.	
18	POLA2		Selects polarity of the MCOA2 and MCOB2 pins.	0
		0	Passive state is LOW, active state is HIGH.	
		1	Passive state is HIGH, active state is LOW.	
19	DTE2		Controls the dead-time feature for channel 1.	0
		0	Dead-time disabled.	
		1	Dead-time enabled.	
20	DISUP2		Enable/disable updates of functional registers for channel 2 (see Section 31.8.2).	0
		0	Functional registers are updated from the write registers at the end of each PWM cycle.	
		1	Functional registers remain the same as long as the timer is running.	
28:21	-	-	Reserved.	
29	INVBDC		Controls the polarity of the MCOB outputs for all 3 channels in 3-phase DC mode (typically set to 1). In other modes, the value of this bit has no effect.	
		0	The MCOB outputs have opposite polarity from the MCOA outputs (aside from dead time).	
		1	The MCOB outputs have the same basic polarity as the MCOA outputs. (see Section 31.8.6)	
30	ACMODE		3-phase AC mode select (see Section 31.8.7).	0
		0	3-phase AC-mode off: Each PWM channel uses its own timer-counter and period register.	
		1	3-phase AC-mode on: All PWM channels use the timer-counter and period register of channel 0.	

Table 723. MCPWM Control read address (CON - 0x400A 0000) bit description

Bit	Symbol	Value	Description	Reset value
31	DCMODE		3-phase DC mode select (see Section 31.8.6).	0
		0	3-phase DC mode off: PWM channels are independent (unless bit ACMODE = 1)	
		1	3-phase DC mode on: The internal MCOA0 output is routed through the CP register (i.e. a mask) register to all six PWM outputs.	

31.7.1.2 MCPWM Control set address

Writing ones to this write-only address sets the corresponding bits in MCON.

Table 724. MCPWM Control set address (CON_SET - 0x400A 0004) bit description

Bit	Symbol	Description	Reset value
0	RUN0_SET	Writing a one sets the corresponding bit in the CON register.	-
1	CENTER0_SET	Writing a one sets the corresponding bit in the CON register.	-
2	POLA0_SET	Writing a one sets the corresponding bit in the CON register.	-
3	DTE0_SET	Writing a one sets the corresponding bit in the CON register.	-
4	DISUP0_SET	Writing a one sets the corresponding bit in the CON register.	-
7:5	-	Writing a one sets the corresponding bit in the CON register.	-
8	RUN1_SET	Writing a one sets the corresponding bit in the CON register.	-
9	CENTER1_SET	Writing a one sets the corresponding bit in the CON register.	-
10	POLA1_SET	Writing a one sets the corresponding bit in the CON register.	-
11	DTE1_SET	Writing a one sets the corresponding bit in the CON register.	-
12	DISUP1_SET	Writing a one sets the corresponding bit in the CON register.	-
15:13	-	Writing a one sets the corresponding bit in the CON register.	-
16	RUN2_SET	Writing a one sets the corresponding bit in the CON register.	-
17	CENTER2_SET	Writing a one sets the corresponding bit in the CON register.	-
18	POLA2_SET	Writing a one sets the corresponding bit in the CON register.	-
19	DTE2_SET	Writing a one sets the corresponding bit in the CON register.	-
20	DISUP2_SET	Writing a one sets the corresponding bit in the CON register.	-
28:21	-	Writing a one sets the corresponding bit in the CON register.	-
29	INVBDC_SET	Writing a one sets the corresponding bit in the CON register.	-
30	ACMODE_SET	Writing a one sets the corresponding bit in the CON register.	-
31	DCMODE_SET	Writing a one sets the corresponding bit in the CON register.	-

31.7.1.3 MCPWM Control clear address

Writing ones to this write-only address clears the corresponding bits in CON.

Table 725. MCPWM Control clear address (CON_CLR - 0x400A 0008) bit description

Bit	Symbol	Description	Reset value
0	RUN0_CLR	Writing a one clears the corresponding bit in the CON register.	-
1	CENTER0_CLR	Writing a one clears the corresponding bit in the CON register.	-
2	POLA0_CLR	Writing a one clears the corresponding bit in the CON register.	-
3	DTE0_CLR	Writing a one clears the corresponding bit in the CON register.	-

Table 725. MCPWM Control clear address (CON_CLR - 0x400A 0008) bit description

Bit	Symbol	Description	Reset value
4	DISUP0_CLR	Writing a one clears the corresponding bit in the CON register.	-
7:5	-	Writing a one clears the corresponding bit in the CON register.	-
8	RUN1_CLR	Writing a one clears the corresponding bit in the CON register.	-
9	CENTER1_CLR	Writing a one clears the corresponding bit in the CON register.	-
10	POLA1_CLR	Writing a one clears the corresponding bit in the CON register.	-
11	DTE1_CLR	Writing a one clears the corresponding bit in the CON register.	-
12	DISUP1_CLR	Writing a one clears the corresponding bit in the CON register.	-
15:13	-	Writing a one clears the corresponding bit in the CON register.	-
16	RUN2_CLR	Writing a one clears the corresponding bit in the CON register.	-
17	CENTER2_CLR	Writing a one clears the corresponding bit in the CON register.	-
18	POLA2_CLR	Writing a one clears the corresponding bit in the CON register.	-
19	DTE2_CLR	Writing a one clears the corresponding bit in the CON register.	-
20	DISUP2_CLR	Writing a one clears the corresponding bit in the CON register.	-
28:21	-	Writing a one clears the corresponding bit in the CON register.	-
29	INVBDC_CLR	Writing a one clears the corresponding bit in the CON register.	-
30	ACMOD_CLR	Writing a one clears the corresponding bit in the CON register.	-
31	DCMODE_CLR	Writing a one clears the corresponding bit in the CON register.	-

31.7.2 PWM Capture Control register

31.7.2.1 MCPWM Capture Control read address

The MCCAPCON register controls detection of events on the MCI0-2 inputs for all MCPWM channels. Any of the three MCI inputs can be used to trigger a capture event on any or all of the three channels. This address is read-only, but the underlying register can be modified by writing to addresses CAPCON_SET and CAPCON_CLR.

Table 726. MCPWM Capture Control read address (CAPCON - 0x400A 000C) bit description

Bit	Symbol	Description	Reset value
0	CAP0MCI0_RE	A 1 in this bit enables a channel 0 capture event on a rising edge on MCI0.	0
1	CAP0MCI0_FE	A 1 in this bit enables a channel 0 capture event on a falling edge on MCI0.	0
2	CAP0MCI1_RE	A 1 in this bit enables a channel 0 capture event on a rising edge on MCI1.	0
3	CAP0MCI1_FE	A 1 in this bit enables a channel 0 capture event on a falling edge on MCI1.	0
4	CAP0MCI2_RE	A 1 in this bit enables a channel 0 capture event on a rising edge on MCI2.	0
5	CAP0MCI2_FE	A 1 in this bit enables a channel 0 capture event on a falling edge on MCI2.	0
6	CAP1MCI0_RE	A 1 in this bit enables a channel 1 capture event on a rising edge on MCI0.	0
7	CAP1MCI0_FE	A 1 in this bit enables a channel 1 capture event on a falling edge on MCI0.	0
8	CAP1MCI1_RE	A 1 in this bit enables a channel 1 capture event on a rising edge on MCI1.	0
9	CAP1MCI1_FE	A 1 in this bit enables a channel 1 capture event on a falling edge on MCI1.	0
10	CAP1MCI2_RE	A 1 in this bit enables a channel 1 capture event on a rising edge on MCI2.	0

Table 726. MCPWM Capture Control read address (CAPCON - 0x400A 000C) bit description

Bit	Symbol	Description	Reset value
11	CAP1MCI2_FE	A 1 in this bit enables a channel 1 capture event on a falling edge on MCI2.	0
12	CAP2MCI0_RE	A 1 in this bit enables a channel 2 capture event on a rising edge on MCI0.	0
13	CAP2MCI0_FE	A 1 in this bit enables a channel 2 capture event on a falling edge on MCI0.	0
14	CAP2MCI1_RE	A 1 in this bit enables a channel 2 capture event on a rising edge on MCI1.	0
15	CAP2MCI1_FE	A 1 in this bit enables a channel 2 capture event on a falling edge on MCI1.	0
16	CAP2MCI2_RE	A 1 in this bit enables a channel 2 capture event on a rising edge on MCI2.	0
17	CAP2MCI2_FE	A 1 in this bit enables a channel 2 capture event on a falling edge on MCI2.	0
18	RT0	If this bit is 1, TC0 is reset by a channel 0 capture event.	0
19	RT1	If this bit is 1, TC1 is reset by a channel 1 capture event.	0
20	RT2	If this bit is 1, TC2 is reset by a channel 2 capture event.	0
31:21	-	Reserved.	-

31.7.2.2 MCPWM Capture Control set address

Writing ones to this write-only address sets the corresponding bits in CAPCON.

Table 727. MCPWM Capture Control set address (CAPCON_SET - 0x400A 0010) bit description

Bit	Symbol	Description	Reset value
0	CAP0MCI0_RE_SET	Writing a one sets the corresponding bits in the CAPCON register.	-
1	CAP0MCI0_FE_SET	Writing a one sets the corresponding bits in the CAPCON register.	-
2	CAP0MCI1_RE_SET	Writing a one sets the corresponding bits in the CAPCON register.	-
3	CAP0MCI1_FE_SET	Writing a one sets the corresponding bits in the CAPCON register.	-
4	CAP0MCI2_RE_SET	Writing a one sets the corresponding bits in the CAPCON register.	-
5	CAP0MCI2_FE_SET	Writing a one sets the corresponding bits in the CAPCON register.	-
6	CAP1MCI0_RE_SET	Writing a one sets the corresponding bits in the CAPCON register.	-
7	CAP1MCI0_FE_SET	Writing a one sets the corresponding bits in the CAPCON register.	-
8	CAP1MCI1_RE_SET	Writing a one sets the corresponding bits in the CAPCON register.	-
9	CAP1MCI1_FE_SET	Writing a one sets the corresponding bits in the CAPCON register.	-
10	CAP1MCI2_RE_SET	Writing a one sets the corresponding bits in the CAPCON register.	-
11	CAP1MCI2_FE_SET	Writing a one sets the corresponding bits in the CAPCON register.	-
12	CAP2MCI0_RE_SET	Writing a one sets the corresponding bits in the CAPCON register.	-

Table 727. MCPWM Capture Control set address (CAPCON_SET - 0x400A 0010) bit description

Bit	Symbol	Description	Reset value
13	CAP2MCI0_FE_SET	Writing a one sets the corresponding bits in the CAPCON register.	-
14	CAP2MCI1_RE_SET	Writing a one sets the corresponding bits in the CAPCON register.	-
15	CAP2MCI1_FE_SET	Writing a one sets the corresponding bits in the CAPCON register.	-
16	CAP2MCI2_RE_SET	Writing a one sets the corresponding bits in the CAPCON register.	-
17	CAP2MCI2_FE_SET	Writing a one sets the corresponding bits in the CAPCON register.	-
18	RT0_SET	Writing a one sets the corresponding bits in the CAPCON register.	-
19	RT1_SET	Writing a one sets the corresponding bits in the CAPCON register.	-
20	RT2_SET	Writing a one sets the corresponding bits in the CAPCON register.	-
31:21	-	Reserved.	-

31.7.2.3 MCPWM Capture control clear address

Writing ones to this write-only address clears the corresponding bits in MCCAPCON.

Table 728. MCPWM Capture control clear register (CAPCON_CLR - address 0x400A 0014) bit description

Bit	Symbol	Description	Reset value
0	CAP0MCI0_RE_CLR	Writing a one clears the corresponding bits in the CAPCON register.	-
1	CAP0MCI0_FE_CLR	Writing a one clears the corresponding bits in the CAPCON register.	-
2	CAP0MCI1_RE_CLR	Writing a one clears the corresponding bits in the CAPCON register.	-
3	CAP0MCI1_FE_CLR	Writing a one clears the corresponding bits in the CAPCON register.	-
4	CAP0MCI2_RE_CLR	Writing a one clears the corresponding bits in the CAPCON register.	-
5	CAP0MCI2_FE_CLR	Writing a one clears the corresponding bits in the CAPCON register.	-
6	CAP1MCI0_RE_CLR	Writing a one clears the corresponding bits in the CAPCON register.	-
7	CAP1MCI0_FE_CLR	Writing a one clears the corresponding bits in the CAPCON register.	-
8	CAP1MCI1_RE_CLR	Writing a one clears the corresponding bits in the CAPCON register.	-
9	CAP1MCI1_FE_CLR	Writing a one clears the corresponding bits in the CAPCON register.	-

Table 728. MCPWM Capture control clear register (CAPCON_CLR - address 0x400A 0014) bit description

Bit	Symbol	Description	Reset value
10	CAP1MCI2_RE_CLR	Writing a one clears the corresponding bits in the CAPCON register.	-
11	CAP1MCI2_FE_CLR	Writing a one clears the corresponding bits in the CAPCON register.	-
12	CAP2MCI0_RE_CLR	Writing a one clears the corresponding bits in the CAPCON register.	-
13	CAP2MCI0_FE_CLR	Writing a one clears the corresponding bits in the CAPCON register.	-
14	CAP2MCI1_RE_CLR	Writing a one clears the corresponding bits in the CAPCON register.	-
15	CAP2MCI1_FE_CLR	Writing a one clears the corresponding bits in the CAPCON register.	-
16	CAP2MCI2_RE_CLR	Writing a one clears the corresponding bits in the CAPCON register.	-
17	CAP2MCI2_FE_CLR	Writing a one clears the corresponding bits in the CAPCON register.	-
18	RT0_CLR	Writing a one clears the corresponding bits in the CAPCON register.	-
19	RT1_CLR	Writing a one clears the corresponding bits in the CAPCON register.	-
20	RT2_CLR	Writing a one clears the corresponding bits in the CAPCON register.	-
31:21	-	Reserved.	-

31.7.3 MCPWM Timer/Counter 0-2 registers

These registers hold the current values of the 32-bit counter/timers for channels 0-2. Each value is incremented on every PCLK, or by edges on the MCI0-2 pins, as selected by CNTCON. The timer/counter counts up from 0 until it reaches the value in its corresponding PER register (or is stopped by writing to CON_CLR).

A TC register can be read at any time. In order to write to the TC register, its channel must be stopped. If not, the write will not take place, no exception is generated.

Table 729. MCPWM Timer/Counter 0 to 2 registers (TC - 0x400A 0018 (TC0), 0x400A 001C (TC1), 0x400A 0020) (TC2) bit description

Bit	Symbol	Description	Reset value
31:0	MCTC	Timer/Counter value.	0

31.7.4 MCPWM Limit 0-2 registers

These registers hold the limiting values for timer/counters 0-2. When a timer/counter reaches its corresponding limiting value: 1) in edge-aligned mode, it is reset and starts over at 0; 2) in center-aligned mode, it begins counting down until it reaches 0, at which time it begins counting up again.

If the channel's CENTER bit in CON is 0 selecting edge-aligned mode, the match between TC and LIM switches the channel's A output from "active" to "passive" state. If the channel's CENTER and DTE bits in CON are both 0, the match simultaneously switches the channel's B output from "passive" to "active" state.

If the channel's CENTER bit is 0 but the DTE bit is 1, the match triggers the channel's deadtime counter to begin counting -- when the deadtime counter expires, the channel's B output switches from "passive" to "active" state.

In center-aligned mode, matches between a channel's TC and LIM registers have no effect on its A and B outputs.

Writing to either a Limit or a Match (31.7.5) register loads a "write" register, and if the channel is stopped it also loads an "operating" register that is compared to the TC. If the channel is running and its "disable update" bit in CON is 0, the operating registers are loaded from the write registers: 1) in edge-aligned mode, when the TC matches the operating Limit register; 2) in center-aligned mode, when the TC counts back down to 0. If the channel is running and the "disable update" bit is 1, the operating registers are not loaded from the write registers until software stops the channel.

Reading an LIM address always returns the operating value.

Table 730. MCPWM Limit 0 to 2 registers (LIM - 0x400A 0024 (LIM0), 0x400A 0028 (LIM1), 0x400A 002C (LIM2)) bit description

Bit	Symbol	Description	Reset value
31:0	MCLIM	Limit value.	0xFFFF FFFF

Remark: In timer mode, the period of a channel's modulated MCO outputs is determined by its Limit register, and the pulse width at the start of the period is determined by its Match register. If it suits your way of thinking, consider the Limit register to be the "Period register" and the Match register to be the "Pulse Width register".

31.7.5 MCPWM Match 0-2 registers

These registers also have "write" and "operating" versions as described above for the Limit registers, and the operating registers are also compared to the channels' TCs. See 31.7.4 above for details of reading and writing both Limit and Match registers.

The Match and Limit registers control the MCO0-2 outputs. If a Match register is to have any effect on its channel's operation, it must contain a smaller value than the corresponding Limit register.

Table 731. MCPWM Match 0 to 2 registers (MAT - addresses 0x400A 0030 (MAT0), 0x400A 0034 (MAT1), 0x400A 0038 (MAT2)) bit description

Bit	Symbol	Description	Reset value
31:0	MCMAT	Match value.	0xFFFF FFFF

31.7.5.1 Match register in Edge-Aligned mode

If the channel's CENTER bit in CON is 0 selecting edge-aligned mode, a match between TC and MAT switches the channel's B output from "active" to "passive" state. If the channel's CENTER and DTE bits in CON are both 0, the match simultaneously switches the channel's A output from "passive" to "active" state.

If the channel's CENTER bit is 0 but the DTE bit is 1, the match triggers the channel's deadtime counter to begin counting -- when the deadtime counter expires, the channel's A output switches from "passive" to "active" state.

31.7.5.2 Match register in Center-Aligned mode

If the channel's CENTER bit in CON is 1 selecting center-aligned mode, a match between TC and MAT while the TC is incrementing switches the channel's B output from "active" to "passive" state, and a match while the TC is decrementing switches the A output from "active" to "passive". If the channel's CENTER bit in CON is 1 but the DTE bit is 0, a match simultaneously switches the channel's other output in the opposite direction.

If the channel's CENTER and DTE bits are both 1, a match between TC and MAT triggers the channel's deadtime counter to begin counting -- when the deadtime counter expires, the channel's B output switches from "passive" to "active" if the TC was counting up at the time of the match, and the channel's A output switches from "passive" to "active" if the TC was counting down at the time of the match.

31.7.5.3 0 and 100% duty cycle

To lock a channel's MCO outputs at the state "B active, A passive", write its Match register with a higher value than you write to its Limit register. The match never occurs.

To lock a channel's MCO outputs at the opposite state, "A active, B passive", simply write 0 to its Match register.

31.7.6 MCPWM Dead-time register

This register holds the dead-time values for the three channels. If a channel's DTE bit in CON is 1 to enable its dead-time counter, the counter counts down from this value whenever one its channel's outputs changes from "active" to "passive" state. When the dead-time counter reaches 0, the channel changes its other output from "passive" to "active" state.

The motivation for the dead-time feature is that power transistors, like those driven by the A and B outputs in a motor-control application, take longer to fully turn off than they take to start to turn on. If the A and B transistors are ever turned on at the same time, a wasteful and damaging current will flow between the power rails through the transistors. In such applications, the dead-time register should be programmed with the number of PCLK periods that is greater than or equal to the transistors' maximum turn-off time minus their minimum turn-on time.

Table 732. MCPWM Dead-time register (DT - address 0x400A 003C) bit description

Bit	Symbol	Description	Reset value
9:0	DT0	Dead time for channel 0. [1]	0x3FF
19:10	DT1	Dead time for channel 1. [2]	0x3FF
29:20	DT2	Dead time for channel 2. [2]	0x3FF
31:30	-	reserved	

[1] If ACMODE is 1 selecting AC-mode, this field controls the dead time for all three channels.

[2] If ACMODE is 0.

31.7.7 MCPWM Communication Pattern register

This register is used in DC mode only. The internal MCOA0 signal is routed to any or all of the six output pins under the control of the bits in this register. Like the Match and Limit registers, this register has “write” and “operational” versions. See [31.7.4](#) and [31.8.2](#) for more about this subject.

Table 733. MCPWM Communication Pattern register (CP - address 0x400A 0040) bit description

Bit	Symbol	Value	Description	Reset value
0	CCPA0		Communication pattern output A, channel 0.	0
		0	MCOA0 passive.	
		1	internal MCOA0.	
1	CCPB0		Communication pattern output B, channel 0.	0
		0	MCOB0 passive.	
		1	MCOB0 tracks internal MCOA0.	
2	CCPA1		Communication pattern output A, channel 1.	0
		0	MCOA1 passive.	
		1	MCOA1 tracks internal MCOA0.	
3	CCPB1		Communication pattern output B, channel 1.	0
		0	MCOB1 passive.	
		1	MCOB1 tracks internal MCOA0.	
4	CCPA2		Communication pattern output A, channel 2.	0
		0	MCOA2 passive.	
		1	MCOA2 tracks internal MCOA0.	
5	CCPB2		Communication pattern output B, channel 2.	0
		0	MCOB2 passive.	
		1	MCOB2 tracks internal MCOA0.	
31:6	-		Reserved.	

31.7.8 MCPWM Capture read addresses

The CAPCON register ([Table 726](#)) allows software to select any edge(s) on any of the MCI0-2 inputs as a capture event for each channel. When a channel’s capture event occurs, the current TC value for that channel is stored in its read-only Capture register. These addresses are read-only, but the underlying registers can be cleared by writing to the CAP_CLR address

Table 734. MCPWM Capture read addresses (CAP - 0x400A 0044 (CAP0), 0x400A 0048 (CAP1), 0x400A 004C 9CAP2)) bit description

Bit	Symbol	Description	Reset value
31:0	CAP	Current TC value at a capture event.	0x0000 0000

31.7.9 MCPWM Interrupt registers

The Motor Control PWM module includes the following interrupt sources:

Table 735. Motor Control PWM interrupts

Symbol	Description
ILIM0/1/2	Limit interrupts for channels 0, 1, 2.
IMAT0/1/2	Match interrupts for channels 0, 1, 2.
ICAP0/1/2	Capture interrupts for channels 0, 1, 2.
ABORT	Fast abort interrupt

7.9.1 MCPWM Interrupt Enable read address

The INTEN register controls which of the MCPWM interrupts are enabled. This address is read-only, but the underlying register can be modified by writing to addresses INTEN_SET and INTEN_CLR.

Table 736. MCPWM Interrupt Enable read address (INTEN - 0x400A 0050) bit description

Bit	Symbol	Value	Description	Reset value
0	ILIM0		Limit interrupt for channel 0.	0
		0	Interrupt disabled.	
		1	Interrupt enabled.	
1	IMAT0		Match interrupt for channel 0.	0
		0	Interrupt disabled.	
		1	Interrupt enabled.	
2	ICAP0		Capture interrupt for channel 0.	0
		0	Interrupt disabled.	
		1	Interrupt enabled.	
3	-		Reserved.	-
4	ILIM1		Limit interrupt for channel 1.	0
		0	Interrupt disabled.	
		1	Interrupt enabled.	
5	IMAT1		Match interrupt for channel 1.	0
		0	Interrupt disabled.	
		1	Interrupt enabled.	
6	ICAP1		Capture interrupt for channel 1.	0
		0	Interrupt disabled.	
		1	Interrupt enabled.	
7	-		Reserved.	-
8	ILIM2		Limit interrupt for channel 2.	0
		0	Interrupt disabled.	
		1	Interrupt enabled.	
9	IMAT2		Match interrupt for channel 2.	0
		0	Interrupt disabled.	
		1	Interrupt enabled.	

Table 736. MCPWM Interrupt Enable read address (INTEN - 0x400A 0050) bit description

Bit	Symbol	Value	Description	Reset value
10	ICAP2		Capture interrupt for channel 2.	0
		0	Interrupt disabled.	
		1	Interrupt enabled.	
14:11	-		Reserved.	-
15	ABORT		Fast abort interrupt.	0
		0	Interrupt disabled.	
		1	Interrupt enabled.	
31:16	-		Reserved.	-

31.7.9.2 MCPWM Interrupt Enable set address

Writing ones to this write-only address sets the corresponding bits in INTEN, thus enabling interrupts.

Table 737. MCPWM interrupt enable set register (INTEN_SET - address 0x400A 0054) bit description

Bit	Symbol	Description	Reset value
0	ILIM0_SET	Writing a one sets the corresponding bit in INTEN, thus enabling the interrupt.	-
1	IMAT0_SET	Writing a one sets the corresponding bit in INTEN, thus enabling the interrupt.	-
2	ICAP0_SET	Writing a one sets the corresponding bit in INTEN, thus enabling the interrupt.	-
3	-	Reserved.	-
4	ILIM1_SET	Writing a one sets the corresponding bit in INTEN, thus enabling the interrupt.	-
5	IMAT1_SET	Writing a one sets the corresponding bit in INTEN, thus enabling the interrupt.	-
6	ICAP1_SET	Writing a one sets the corresponding bit in INTEN, thus enabling the interrupt.	-
7	-	Reserved.	-
9	ILIM2_SET	Writing a one sets the corresponding bit in INTEN, thus enabling the interrupt.	-
10	IMAT2_SET	Writing a one sets the corresponding bit in INTEN, thus enabling the interrupt.	-
11	ICAP2_SET	Writing a one sets the corresponding bit in INTEN, thus enabling the interrupt.	-
14:12	-	Reserved.	-
15	ABORT_SET	Writing a one sets the corresponding bit in INTEN, thus enabling the interrupt.	-
31:16	-	Reserved.	-

31.7.9.3 MCPWM Interrupt Enable clear address

Writing ones to this write-only address clears the corresponding bits in INTEN, thus disabling interrupts.

Table 738. PWM interrupt enable clear register (INTEN_CLR - address 0x400A 0058) bit description

Bit	Symbol	Description	Reset value
0	ILIM0_CLR	Writing a one clears the corresponding bit in INTEN, thus disabling the interrupt.	-
1	IMAT0_CLR	Writing a one clears the corresponding bit in INTEN, thus disabling the interrupt.	-
2	ICAP0_CLR	Writing a one clears the corresponding bit in INTEN, thus disabling the interrupt.	-
3	-	Reserved.	-
4	ILIM1_CLR	Writing a one clears the corresponding bit in INTEN, thus disabling the interrupt.	-
5	IMAT1_CLR	Writing a one clears the corresponding bit in INTEN, thus disabling the interrupt.	-
6	ICAP1_CLR	Writing a one clears the corresponding bit in INTEN, thus disabling the interrupt.	-
7	-	Reserved.	-
8	ILIM2_CLR	Writing a one clears the corresponding bit in INTEN, thus disabling the interrupt.	-
9	IMAT2_CLR	Writing a one clears the corresponding bit in INTEN, thus disabling the interrupt.	-
10	ICAP2_CLR	Writing a one clears the corresponding bit in INTEN, thus disabling the interrupt.	-
14:11	-	Reserved.	-
15	ABORT_CLR	Writing a one clears the corresponding bit in INTEN, thus disabling the interrupt.	-
31:16	-	Reserved.	-

31.7.10 MCPWM Count Control register

31.7.10.1 MCPWM Count Control read address

The CNTCON register controls whether the MCPWM channels are in timer or counter mode, and in counter mode whether the counter advances on rising and/or falling edges on any or all of the three MCI inputs. If timer mode is selected, the counter advances based on the PCLK clock.

This address is read-only. To set or clear the register bits, write ones to the CNTCON_SET or CNTCON_CLR address.

Table 739. MCPWM Count Control read address (CNTCON - 0x400A 005C) bit description

Bit	Symbol	Value	Description	Reset value
0	TC0MCI0_RE		Counter 0 rising edge mode, channel 0.	0
		0	A rising edge on MCI0 does not affect counter 0.	
		1	If MODE0 is 1, counter 0 advances on a rising edge on MCI0.	

Table 739. MCPWM Count Control read address (CNTCON - 0x400A 005C) bit description

Bit	Symbol	Value	Description	Reset value
1	TC0MCI0_FE		Counter 0 falling edge mode, channel 0.	0
		0	A falling edge on MCI0 does not affect counter 0.	
		1	If MODE0 is 1, counter 0 advances on a falling edge on MCI0.	
2	TC0MCI1_RE		Counter 0 rising edge mode, channel 1.	0
		0	A rising edge on MCI1 does not affect counter 0.	
		1	If MODE0 is 1, counter 0 advances on a rising edge on MCI1.	
3	TC0MCI1_FE		Counter 0 falling edge mode, channel 1.	0
		0	A falling edge on MCI1 does not affect counter 0.	
		1	If MODE0 is 1, counter 0 advances on a falling edge on MCI1.	
4	TC0MCI2_RE		Counter 0 rising edge mode, channel 2.	0
		0	A rising edge on MCI0 does not affect counter 0.	
		1	If MODE0 is 1, counter 0 advances on a rising edge on MCI2.	
5	TC0MCI2_FE		Counter 0 falling edge mode, channel 2.	0
		0	A falling edge on MCI0 does not affect counter 0.	
		1	If MODE0 is 1, counter 0 advances on a falling edge on MCI2.	
6	TC1MCI0_RE		Counter 1 rising edge mode, channel 0.	0
		0	A rising edge on MCI0 does not affect counter 1.	
		1	If MODE1 is 1, counter 1 advances on a rising edge on MCI0.	
7	TC1MCI0_FE		Counter 1 falling edge mode, channel 0.	0
		0	A falling edge on MCI0 does not affect counter 1.	
		1	If MODE1 is 1, counter 1 advances on a falling edge on MCI0.	
8	TC1MCI1_RE		Counter 1 rising edge mode, channel 1.	0
		0	A rising edge on MCI1 does not affect counter 1.	
		1	If MODE1 is 1, counter 1 advances on a rising edge on MCI1.	
9	TC1MCI1_FE		Counter 1 falling edge mode, channel 1.	0
		0	A falling edge on MCI0 does not affect counter 1.	
		1	If MODE1 is 1, counter 1 advances on a falling edge on MCI1.	
10	TC1MCI2_RE		Counter 1 rising edge mode, channel 2.	0
		0	A rising edge on MCI2 does not affect counter 1.	
		1	If MODE1 is 1, counter 1 advances on a rising edge on MCI2.	
11	TC1MCI2_FE		Counter 1 falling edge mode, channel 2.	0
		0	A falling edge on MCI2 does not affect counter 1.	
		1	If MODE1 is 1, counter 1 advances on a falling edge on MCI2.	
12	TC2MCI0_RE		Counter 2 rising edge mode, channel 0.	0
		0	A rising edge on MCI0 does not affect counter 2.	
		1	If MODE2 is 1, counter 2 advances on a rising edge on MCI0.	
13	TC2MCI0_FE		Counter 2 falling edge mode, channel 0.	0
		0	A falling edge on MCI0 does not affect counter 2.	
		1	If MODE2 is 1, counter 2 advances on a falling edge on MCI0.	

Table 739. MCPWM Count Control read address (CNTCON - 0x400A 005C) bit description

Bit	Symbol	Value	Description	Reset value
14	TC2MCI1_RE		Counter 2 rising edge mode, channel 1.	0
		0	A rising edge on MCI1 does not affect counter 2.	
		1	If MODE2 is 1, counter 2 advances on a rising edge on MCI1.	
15	TC2MCI1_FE		Counter 2 falling edge mode, channel 1.	0
		0	A falling edge on MCI1 does not affect counter 2.	
		1	If MODE2 is 1, counter 2 advances on a falling edge on MCI1.	
16	TC2MCI2_RE		Counter 2 rising edge mode, channel 2.	0
		0	A rising edge on MCI2 does not affect counter 2.	
		1	If MODE2 is 1, counter 2 advances on a rising edge on MCI2.	
17	TC2MCI2_FE		Counter 2 falling edge mode, channel 2.	0
		0	A falling edge on MCI2 does not affect counter 2.	
		1	If MODE2 is 1, counter 2 advances on a falling edge on MCI2.	
28:18	-	-	Reserved.	-
29	CNTR0		Channel 0 counter/timer mode.	0
		0	Channel 0 is in timer mode.	
		1	Channel 0 is in counter mode.	
30	CNTR1		Channel 1 counter/timer mode.	0
		0	Channel 1 is in timer mode.	
		1	Channel 1 is in counter mode.	
31	CNTR2		Channel 2 counter/timer mode.	0
		0	Channel 2 is in timer mode.	
		1	Channel 2 is in counter mode.	

31.7.10.2 MCPWM Count Control set address

Writing one(s) to this write-only address sets the corresponding bit(s) in CNTCON.

Table 740. MCPWM Count Control set address (CNTCON_SET - 0x400A 0060) bit description

Bit	Symbol	Description	Reset value
0	TC0MCI0_RE_SET	Writing a one sets the corresponding bit in the CNTCON register.	-
1	TC0MCI0_FE_SET	Writing a one sets the corresponding bit in the CNTCON register.	-
2	TC0MCI1_RE_SET	Writing a one sets the corresponding bit in the CNTCON register.	-
3	TC0MCI1_FE_SET	Writing a one sets the corresponding bit in the CNTCON register.	-
4	TC0MCI2_RE_SET	Writing a one sets the corresponding bit in the CNTCON register.	-
5	TC0MCI2_FE_SET	Writing a one sets the corresponding bit in the CNTCON register.	-
6	TC1MCI0_RE_SET	Writing a one sets the corresponding bit in the CNTCON register.	-

Table 740. MCPWM Count Control set address (CNTCON_SET - 0x400A 0060) bit description

Bit	Symbol	Description	Reset value
7	TC1MCI0_FE_SET	Writing a one sets the corresponding bit in the CNTCON register.	-
8	TC1MCI1_RE_SET	Writing a one sets the corresponding bit in the CNTCON register.	-
9	TC1MCI1_FE_SET	Writing a one sets the corresponding bit in the CNTCON register.	-
10	TC1MCI2_RE_SET	Writing a one sets the corresponding bit in the CNTCON register.	-
11	TC1MCI2_FE_SET	Writing a one sets the corresponding bit in the CNTCON register.	-
12	TC2MCI0_RE_SET	Writing a one sets the corresponding bit in the CNTCON register.	-
13	TC2MCI0_FE_SET	Writing a one sets the corresponding bit in the CNTCON register.	-
14	TC2MCI1_RE_SET	Writing a one sets the corresponding bit in the CNTCON register.	-
15	TC2MCI1_FE_SET	Writing a one sets the corresponding bit in the CNTCON register.	-
16	TC2MCI2_RE_SET	Writing a one sets the corresponding bit in the CNTCON register.	-
17	TC2MCI2_FE_SET	Writing a one sets the corresponding bit in the CNTCON register.	-
28:18	-	Reserved.	-
29	CNTR0_SET	Writing a one sets the corresponding bit in the CNTCON register.	-
30	CNTR1_SET	Writing a one sets the corresponding bit in the CNTCON register.	-
31	CNTR2_SET	Writing a one sets the corresponding bit in the CNTCON register.	-

31.7.10.3 MCPWM Count Control clear address

Writing one(s) to this write-only address clears the corresponding bit(s) in CNTCON.

Table 741. MCPWM Count Control clear address (CNTCON_CLR - 0x400A 0064) bit description

Bit	Symbol	Description	Reset value
0	TC0MCI0_RE_CLR	Writing a one clears the corresponding bit in the CNTCON register.	-
1	TC0MCI0_FE_CLR	Writing a one clears the corresponding bit in the CNTCON register.	-
2	TC0MCI1_RE_CLR	Writing a one clears the corresponding bit in the CNTCON register.	-
3	TC0MCI1_FE_CLR	Writing a one clears the corresponding bit in the CNTCON register.	-

Table 741. MCPWM Count Control clear address (CNTCON_CLR - 0x400A 0064) bit description

Bit	Symbol	Description	Reset value
4	TC0MCI2_RE	Writing a one clears the corresponding bit in the CNTCON register.	-
5	TC0MCI2_FE_CLR	Writing a one clears the corresponding bit in the CNTCON register.	-
6	TC1MCI0_RE_CLR	Writing a one clears the corresponding bit in the CNTCON register.	-
7	TC1MCI0_FE_CLR	Writing a one clears the corresponding bit in the CNTCON register.	-
8	TC1MCI1_RE_CLR	Writing a one clears the corresponding bit in the CNTCON register.	-
9	TC1MCI1_FE_CLR	Writing a one clears the corresponding bit in the CNTCON register.	-
10	TC1MCI2_RE_CLR	Writing a one clears the corresponding bit in the CNTCON register.	-
11	TC1MCI2_FE_CLR	Writing a one clears the corresponding bit in the CNTCON register.	-
12	TC2MCI0_RE_CLR	Writing a one clears the corresponding bit in the CNTCON register.	-
13	TC2MCI0_FE_CLR	Writing a one clears the corresponding bit in the CNTCON register.	-
14	TC2MCI1_RE_CLR	Writing a one clears the corresponding bit in the CNTCON register.	-
15	TC2MCI1_FE_CLR	Writing a one clears the corresponding bit in the CNTCON register.	-
16	TC2MCI2_RE_CLR	Writing a one clears the corresponding bit in the CNTCON register.	-
17	TC2MCI2_FE_CLR	Writing a one clears the corresponding bit in the CNTCON register.	-
28:18	-	Reserved.	-
29	CNTR0_CLR	Writing a one clears the corresponding bit in the CNTCON register.	-
30	CNTR1_CLR	Writing a one clears the corresponding bit in the CNTCON register.	-
31	CNTR2_CLR	Writing a one clears the corresponding bit in the CNTCON register.	-

31.7.11 MCPWM Interrupt flag registers

31.7.11.1 MCPWM Interrupt Flags read address

The INTF register includes all MCPWM interrupt flags, which are set when the corresponding hardware event occurs, or when ones are written to the INTF_SET address. When corresponding bits in this register and INTEN are both 1, the MCPWM asserts its interrupt request to the Interrupt Controller module. This address is read-only, but the bits in the underlying register can be modified by writing ones to addresses INTF_SET and INTF_CLR.

Table 742. MCPWM Interrupt flags read address (INTF - 0x400A 0068) bit description

Bit	Symbol	Value	Description	Reset value
0	ILIM0_F		Limit interrupt flag for channel 0.	0
		0	This interrupt source is not contributing to the MCPWM interrupt request.	
		1	If the corresponding bit in INTEN is 1, the MCPWM module is asserting its interrupt request to the Interrupt Controller.	
1	IMAT0_F		Match interrupt flag for channel 0.	0
		0	This interrupt source is not contributing to the MCPWM interrupt request.	
		1	If the corresponding bit in INTEN is 1, the MCPWM module is asserting its interrupt request to the Interrupt Controller.	
2	ICAP0_F		Capture interrupt flag for channel 0.	0
		0	This interrupt source is not contributing to the MCPWM interrupt request.	
		1	If the corresponding bit in INTEN is 1, the MCPWM module is asserting its interrupt request to the Interrupt Controller.	
3	-		Reserved.	-
4	ILIM1_F		Limit interrupt flag for channel 1.	0
		0	This interrupt source is not contributing to the MCPWM interrupt request.	
		1	If the corresponding bit in INTEN is 1, the MCPWM module is asserting its interrupt request to the Interrupt Controller.	
5	IMAT1_F		Match interrupt flag for channel 1.	0
		0	This interrupt source is not contributing to the MCPWM interrupt request.	
		1	If the corresponding bit in INTEN is 1, the MCPWM module is asserting its interrupt request to the Interrupt Controller.	
6	ICAP1_F		Capture interrupt flag for channel 1.	0
		0	This interrupt source is not contributing to the MCPWM interrupt request.	
		1	If the corresponding bit in INTEN is 1, the MCPWM module is asserting its interrupt request to the Interrupt Controller.	
7	-		Reserved.	-
8	ILIM2_F		Limit interrupt flag for channel 2.	0
		0	This interrupt source is not contributing to the MCPWM interrupt request.	
		1	If the corresponding bit in INTEN is 1, the MCPWM module is asserting its interrupt request to the Interrupt Controller.	
9	IMAT2_F		Match interrupt flag for channel 2.	0
		0	This interrupt source is not contributing to the MCPWM interrupt request.	
		1	If the corresponding bit in INTEN is 1, the MCPWM module is asserting its interrupt request to the Interrupt Controller.	

Table 742. MCPWM Interrupt flags read address (INTF - 0x400A 0068) bit description

Bit	Symbol	Value	Description	Reset value
10	ICAP2_F		Capture interrupt flag for channel 2.	0
		0	This interrupt source is not contributing to the MCPWM interrupt request.	
		1	If the corresponding bit in INTEN is 1, the MCPWM module is asserting its interrupt request to the Interrupt Controller.	
14:11	-		Reserved.	-
15	ABORT_F		Fast abort interrupt flag.	0
		0	This interrupt source is not contributing to the MCPWM interrupt request.	
		1	If the corresponding bit in INTEN is 1, the MCPWM module is asserting its interrupt request to the Interrupt Controller.	
31:16	-		Reserved.	-

31.7.11.2 MCPWM Interrupt Flags set address

Writing one(s) to this write-only address sets the corresponding bit(s) in INTF, thus possibly simulating hardware interrupt(s).

Table 743. MCPWM Interrupt Flags set address (INTF_SET - 0x400A 006C) bit description

Bit	Symbol	Description	Reset value
0	ILIM0_F_SET	Writing a one sets the corresponding bit in the INTF register, thus possibly simulating hardware interrupt.	-
1	IMAT0_F_SET	Writing a one sets the corresponding bit in the INTF register, thus possibly simulating hardware interrupt.	-
2	ICAP0_F_SET	Writing a one sets the corresponding bit in the INTF register, thus possibly simulating hardware interrupt.	-
3	-	Reserved.	-
4	ILIM1_F_SET	Writing a one sets the corresponding bit in the INTF register, thus possibly simulating hardware interrupt.	-
5	IMAT1_F_SET	Writing a one sets the corresponding bit in the INTF register, thus possibly simulating hardware interrupt.	-
6	ICAP1_F_SET	Writing a one sets the corresponding bit in the INTF register, thus possibly simulating hardware interrupt.	-
7	-	Reserved.	-
8	ILIM2_F_SET	Writing a one sets the corresponding bit in the INTF register, thus possibly simulating hardware interrupt.	-
9	IMAT2_F_SET	Writing a one sets the corresponding bit in the INTF register, thus possibly simulating hardware interrupt.	-
10	ICAP2_F_SET	Writing a one sets the corresponding bit in the INTF register, thus possibly simulating hardware interrupt.	-
14:11	-	Reserved.	-
15	ABORT_F_SET	Writing a one sets the corresponding bit in the INTF register, thus possibly simulating hardware interrupt.	-
31:16	-	Reserved.	-

31.7.11.3 MCPWM Interrupt Flags clear address

Writing one(s) to this write-only address sets the corresponding bit(s) in INTF, thus clearing the corresponding interrupt request(s). This is typically done in interrupt service routines.

Table 744. MCPWM Interrupt Flags clear address (INTF_CLR - 0x400A 0070) bit description

Bit	Symbol	Description	Reset value
0	ILIM0_F_CLR	Writing a one clears the corresponding bit in the INTF register, thus clearing the corresponding interrupt request.	-
1	IMAT0_F_CLR	Writing a one clears the corresponding bit in INTEN, thus disabling the interrupt.	-
2	ICAP0_F_CLR	Writing a one clears the corresponding bit in INTEN, thus disabling the interrupt.	-
3	-	Reserved.	-
4	ILIM1_F_CLR	Writing a one clears the corresponding bit in INTEN, thus disabling the interrupt.	-
5	IMAT1_F_CLR	Writing a one clears the corresponding bit in INTEN, thus disabling the interrupt.	-
6	ICAP1_F_CLR	Writing a one clears the corresponding bit in INTEN, thus disabling the interrupt.	-
7	-	Reserved.	-
8	ILIM2_F_CLR	Writing a one clears the corresponding bit in INTEN, thus disabling the interrupt.	-
9	IMAT2_F_CLR	Writing a one clears the corresponding bit in INTEN, thus disabling the interrupt.	-
10	ICAP2_F_CLR	Writing a one clears the corresponding bit in INTEN, thus disabling the interrupt.	-
14:11	-	Writing a one clears the corresponding bit in INTEN, thus disabling the interrupt.	-
15	ABORT_F_CLR	Writing a one clears the corresponding bit in INTEN, thus disabling the interrupt.	-
31:16	-	Reserved.	-

31.7.12 MCPWM Capture clear address

Writing ones to this write-only address clears the selected CAP register(s).

Table 745. MCPWM Capture clear address (CAP_CLR - 0x400A 0074) bit description

Bit	Symbol	Description
0	CAP_CLR0	Writing a 1 to this bit clears the CAP0 register.
1	CAP_CLR1	Writing a 1 to this bit clears the CAP1 register.
2	CAP_CLR2	Writing a 1 to this bit clears the CAP2 register.
31:3	-	Reserved

31.8 Functional description

31.8.1 Pulse-width modulation

Each channel of the MCPWM has two outputs, A and B, that can drive a pair of transistors to switch a controlled point between two power rails. Most of the time the two outputs have opposite polarity, but a dead-time feature can be enabled (on a per-channel basis) to delay both signals' transitions from "passive" to "active" state so that the transistors are never both turned on simultaneously. In a more general view, the states of each output pair can be thought of "high", "low", and "floating" or "up", "down", and "center-off".

Each channel's mapping from "active" and "passive" to "high" and "low" is programmable. After Reset, the three A outputs are passive/low, and the B outputs are active/high.

The MCPWM can perform edge-aligned and center-aligned pulse-width modulation.

Remark: In timer mode, the period of a channel's modulated MCO outputs is determined by its Limit register, and the pulse width at the start of the period is determined by its Match register. If it suits your way of thinking, consider the Limit register to be the "Period register" and the Match register to be the "Pulse Width register".

Edge-aligned PWM without dead-time

In this mode the timer TC counts up from 0 to the value in the LIM register. As shown in [Figure 100](#), the MCO state is "A passive" until the TC matches the Match register, at which point it changes to "A active". When the TC matches the Limit register, the MCO state changes back to "A passive", and the TC is reset and starts counting up again.

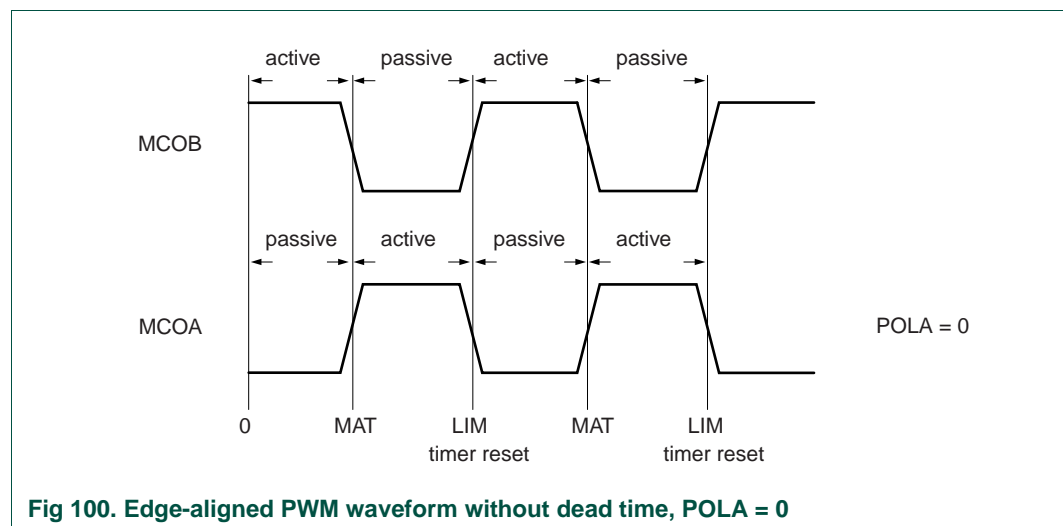

Fig 100. Edge-aligned PWM waveform without dead time, POLA = 0

Center-aligned PWM without dead-time

In this mode the timer TC counts up from 0 to the value in the LIM register, then counts back down to 0 and repeats. As shown in [Figure 101](#), while the timer counts up, the MCO state is "A passive" until the TC matches the Match register, at which point it changes to "A active". When the TC matches the Limit register it starts counting down. When the TC matches the Match register on the way down, the MCO state changes back to "A passive".

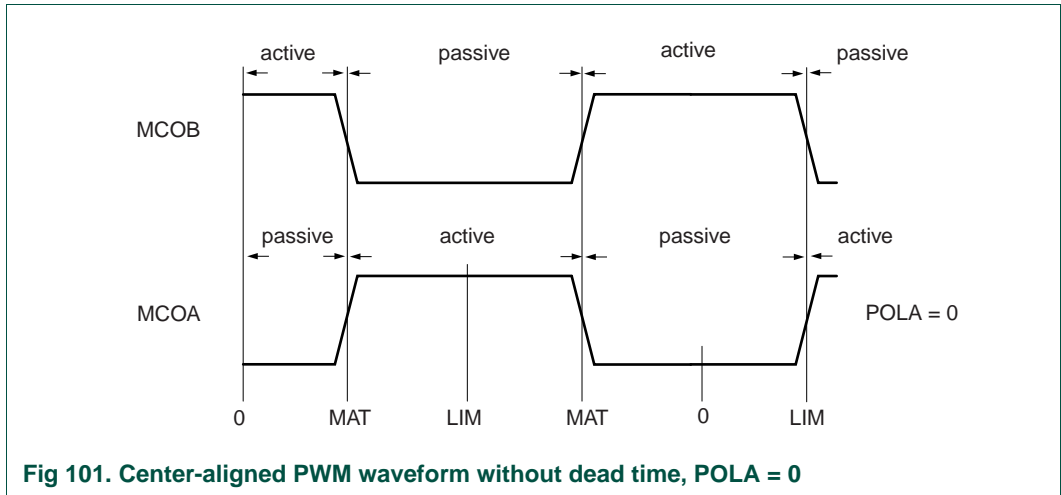

Fig 101. Center-aligned PWM waveform without dead time, POLA = 0

Dead-time counter

When the a channel's DTE bit is set in CON, the dead-time counter delays the passive-to-active transitions of both MCO outputs. The dead-time counter starts counting down, from the channel's DT value (in the DT register) to 0, whenever the channel's A or B output changes from active to passive. The transition of the other output from passive to active is delayed until the dead-time counter reaches 0. During the dead time, the MCOA and MCOB output levels are both passive. [Figure 102](#) shows operation in edge aligned mode with dead time, and [Figure 103](#) shows center-aligned operation with dead time.

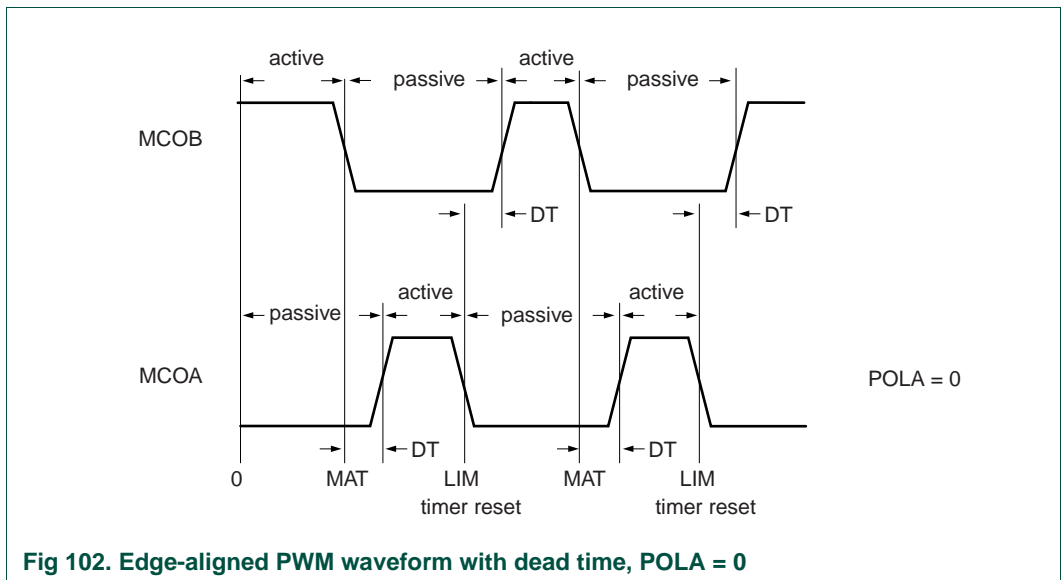

Fig 102. Edge-aligned PWM waveform with dead time, POLA = 0

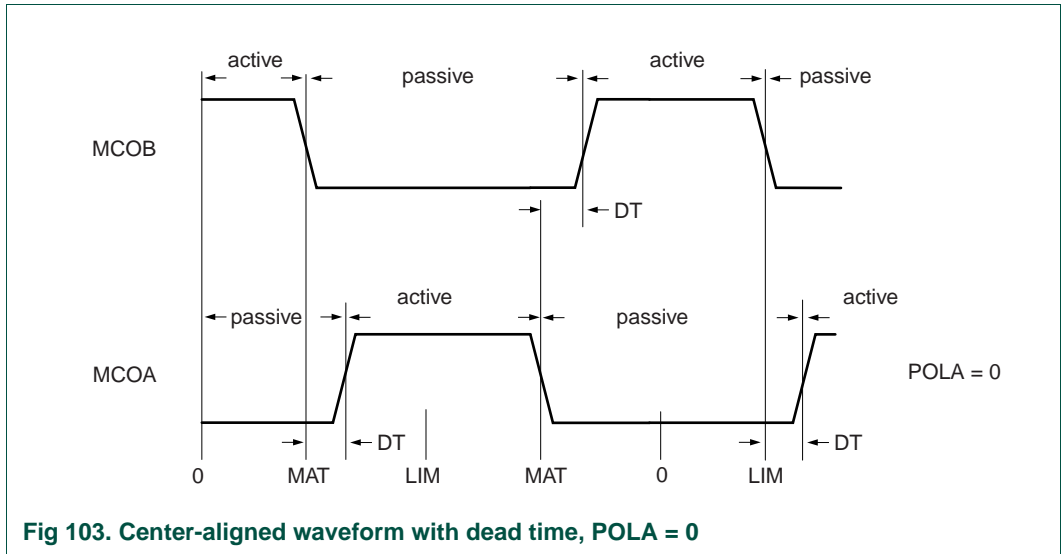

Fig 103. Center-aligned waveform with dead time, POLA = 0

31.8.2 Shadow registers and simultaneous updates

The Limit, Match, and Communication Pattern registers (LIM, MAT, and CP) are implemented as register pairs, each consisting of a write register and an operational register. Software writes into the write registers. The operational registers control the actual operation of each channel and are loaded with the current value in the write registers when the TC starts counting up from 0.

Updating of the functional registers can be disabled by setting a channel’s DISUP bit in the CON register. If the DISUP bits are set, the functional registers are not updated until software stops the channel.

If a channel is not running when software writes to its LIM or MAT register, the functional register is updated immediately.

Software can write to a TC register only when its channel is stopped.

31.8.3 Fast Abort (ABORT)

The MCPWM has an external input $\overline{\text{MCABORT}}$. When this input goes low, all six MCO outputs assume their “A passive” states, and the Abort interrupt is generated if enabled. The outputs remain locked in “A passive” state until the ABORT interrupt flag is cleared or the Abort interrupt is disabled. The ABORT flag may not be cleared before the $\overline{\text{MCABORT}}$ input goes high.

In order to clear an ABORT flag, a 1 must be written to bit 15 of the INTF_CLR register. This will remove the interrupt request. The interrupt can also be disabled by writing a 1 to bit 15 of the INTEN_CLR register.

31.8.4 Capture events

Each PWM channel can take a snapshot of its TC when an input signal transitions. Any channel may use any combination of rising and/or falling edges on any or all of the MCI0-2 inputs as a capture event, under control of the CAPCON register. Rising or falling edges on the inputs are detected synchronously with respect to PCLK.

A capture event on a channel causes the following:

- The current value of the TC is stored in the Capture register (CAP).
- If the channel's capture event interrupt is enabled (see [Table 736](#)), the capture event interrupt flag is set.
- If the channel's RT bit is set in the CAPCON register, enabling reset on a capture event, the input event has the same effect as matching the channel's TC to its LIM register. This includes resetting the TC and switching the MCO pin(s) in edge-aligned mode as described in [31.7.4](#) and [31.8.1](#).

31.8.5 External event counting (Counter mode)

If a channel's MODE bit is 1 in CNTCON, its TC is incremented by rising and/or falling edge(s) (synchronously detected) on the MCI0-2 input(s), rather than by PCLK. The PWM functions and capture functions are unaffected.

31.8.6 Three-phase DC mode

The three-phase DC mode is selected by setting the DCMODE bit in the CON register.

In this mode, the internal MCOA0 signal can be routed to any or all of the MCO outputs. Each MCO output is masked by a bit in the current commutation pattern register CP. If a bit in the CP register is 0, its output pin has the logic level for the passive state of output MCOA0. The polarity of the off state is determined by the POLA0 bit.

All MCO outputs that have 1 bits in the CP register are controlled by the internal MCOA0 signal.

The three MCOB output pins are inverted when the INVBDC bit is 1 in the CON register. This feature accommodates bridge-drivers that have active-low inputs for the low-side switches.

The CP register is implemented as a shadow register pair, so that changes to the active communication pattern occur at the beginning of a new PWM cycle. See [31.7.4](#) and [31.8.2](#) for more about writing and reading such registers.

[Figure 104](#) shows sample waveforms of the MCO outputs in three-phase DC mode. Bits 1 and 3 in the CP register (corresponding to outputs MCOB1 and MCOB0) are set to 0 so that these outputs are masked and in the off state. Their logic level is determined by the POLA0 bit (here, POLA0 = 0 so the passive state is logic LOW). The INVBDC bit is set to 0 (logic level not inverted) so that the B output have the same polarity as the A outputs. Note that this mode differs from other modes in that the MCOB outputs are **not** the opposite of the MCOA outputs.

In the situation shown in [Figure 104](#), bits 0, 2, 4, and 5 in the CP register are set to 1. That means that MCOA1 and both MCO outputs for channel 2 follow the MCOA0 signal.

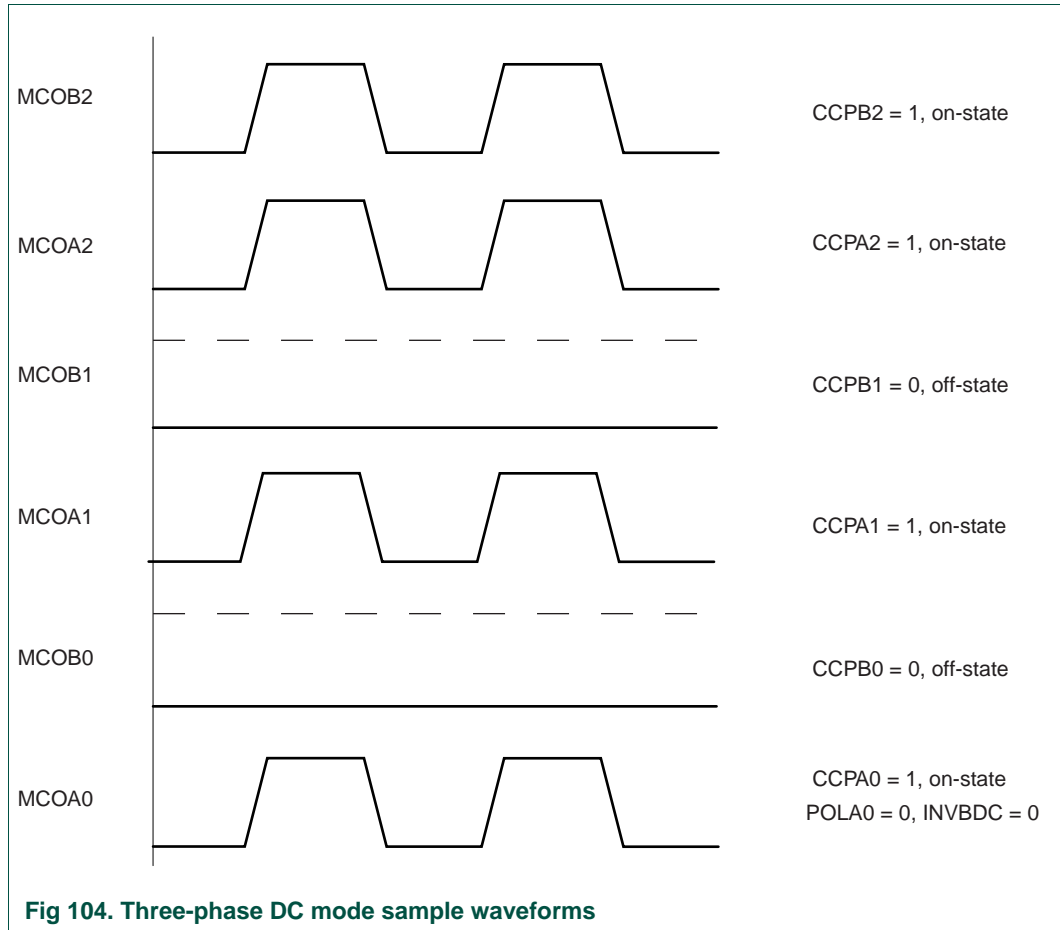

31.8.7 Three phase AC mode

The three-phase AC-mode is selected by setting the ACMODE bit in the CON register.

In this mode, the value of channel 0's TC is routed to all channels for comparison with their MAT registers. (The LIM1-2 registers are not used.)

Each channel controls its MCO output by comparing its MAT value to TC0.

[Figure 105](#) shows sample waveforms for the six MCO outputs in three-phase AC mode. The POLA bits are set to 0 for all three channels, so that for all MCO outputs the active levels are high and the passive levels are low. Each channel has a different MAT value which is compared to the TC0 value. In this mode the period value is identical for all three channels and is determined by LIM0. The dead-time mode is disabled.

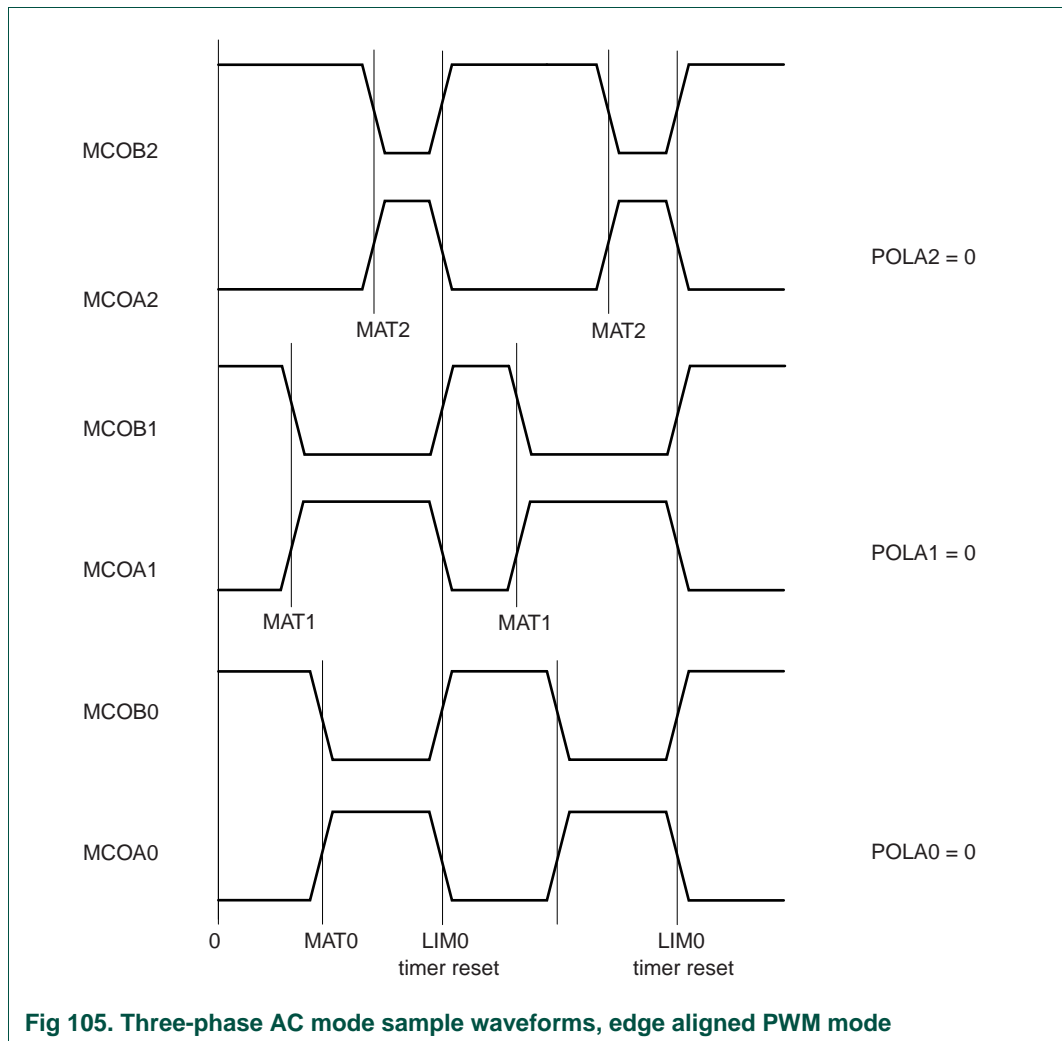

31.8.8 Interrupts

The MCPWM includes 10 possible interrupt sources:

- When any channel's TC matches its Match register.
- When any channel's TC matches its Limit register.
- When any channel captures the value of its TC into its Capture register, because a selected edge occurs on any of MCI0-2.
- When all three channels' outputs are forced to "A passive" state because the MCABORT pin goes low.

[Section 31.7.9 "MCPWM Interrupt registers"](#) explains how to enable these interrupts, and [Section 31.7.2 "PWM Capture Control register"](#) describes how to map edges on the MCI0-2 inputs to "capture events" on the three channels.

32.1 How to read this chapter

The QEI is available on parts LPC185x/3x.

32.2 Basic configuration

The QEI is configured as follows:

- See [Table 746](#) for clocking and power control.
- The QEI is reset by the QEI_RST (reset #39).
- The QEI interrupt is connected to slot # 15 in the Event router.

Table 746. QEI clocking and power control

	Base clock	Branch clock	Operating frequency
Clock to the QEI register interface and QEI peripheral clock.	BASE_M3_CLK	CLK_M3_QEI	up to 180 MHz

32.3 Features

This Quadrature Encoder Interface (QEI) has the following features:

- Tracks encoder position.
- Increments/ decrements depending on direction.
- Programmable for 2X or 4X position counting.
- Velocity capture using built-in timer.
- Velocity compare function with less than interrupt.
- Uses 32-bit registers for position and velocity.
- Three position compare registers with interrupts.
- Index counter for revolution counting.
- Index compare register with interrupts.
- Can combine index and position interrupts to produce an interrupt for whole and partial revolution displacement.
- Digital filter with programmable delays for encoder input signals.
- Can accept decoded signal inputs (clock and direction).

32.4 Introduction

A quadrature encoder, also known as a 2-channel incremental encoder, converts angular displacement into two pulse signals. By monitoring both the number of pulses and the relative phase of the two signals, you can track the position, direction of rotation, and velocity. In addition, a third channel, or index signal, can be used to reset the position counter. This quadrature encoder interface module decodes the digital pulses from a quadrature encoder wheel to integrate position over time and determine direction of rotation. In addition, it can capture the velocity of the encoder wheel.

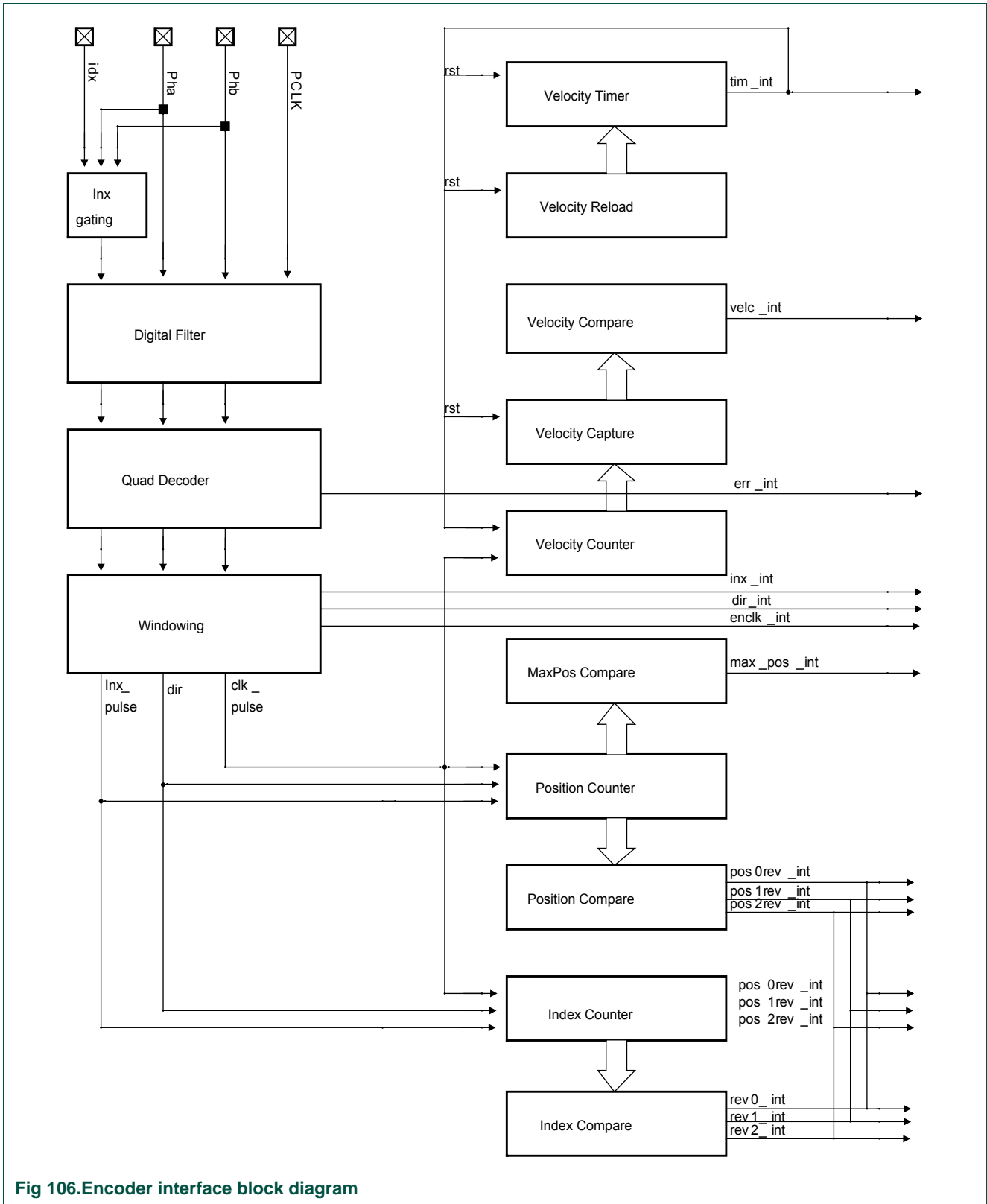

Fig 106.Encoder interface block diagram

32.5 Pin description

Table 747. QEI pin description

Pin function	I/O	Description
QEI_A	I	Used as the Phase A (PhA) input to the Quadrature Encoder Interface.
QEI_B	I	Used as the Phase B (PhB) input to the Quadrature Encoder Interface.
QEI_IDX	I	Used as the Index (IDX) input to the Quadrature Encoder Interface.

32.6 Register description

Table 748. Register overview: QEI (base address 0x400C 6000)

Name	Access	Address offset	Description	Reset value	Reference
Control registers					
CON	WO	0x000	Control register	0	Table 749
STAT	RO	0x004	Encoder status register	0	Table 750
CONF	R/W	0x008	Configuration register	0x000F 0000	Table 751
Position, index, and timer registers					
POS	RO	0x00C	Position register	0	Table 752
MAXPOS	R/W	0x010	Maximum position register	0	Table 753
CMPOS0	R/W	0x014	position compare register 0	0xFFFF FFFF	Table 754
CMPOS1	R/W	0x018	position compare register 1	0xFFFF FFFF	Table 755
CMPOS2	R/W	0x01C	position compare register 2	0xFFFF FFFF	Table 756
INXCNT	RO	0x020	Index count register	0	Table 757
INXCMP0	R/W	0x024	Index compare register 0	0xFFFF FFFF	Table 758
LOAD	R/W	0x028	Velocity timer reload register	0xFFFF FFFF	Table 759
TIME	RO	0x02C	Velocity timer register	0xFFFF FFFF	Table 760
VEL	RO	0x030	Velocity counter register	0	Table 761
CAP	RO	0x034	Velocity capture register	0xFFFF FFFF	Table 762
VELCOMP	R/W	0x038	Velocity compare register	0	Table 763
FILTERPHA	R/W	0x03C	Digital filter register on input phase A (QEI_A)	0	Table 764
FILTERPHB	R/W	0x040	Digital filter register on input phase B (QEI_B)	0	Table 765
FILTERINX	R/W	0x044	Digital filter register on input index (QEI_IDX)	0	Table 766
WINDOW	R/W	0x048	Index acceptance window register	0x0000 0000	Table 767
INXCMP1	R/W	0x04C	Index compare register 1	0xFFFF FFFF	Table 768
INXCMP2	R/W	0x050	Index compare register 2	0xFFFF FFFF	Table 769
Interrupt registers					
IEC	WO	0xFD8	Interrupt enable clear register	0	Table 770
IES	WO	0xFDC	Interrupt enable set register	0	Table 771

Table 748. Register overview: QEI (base address 0x400C 6000)

Name	Access	Address offset	Description	Reset value	Reference
INTSTAT	RO	0xFE0	Interrupt status register	0	Table 772
IE	RO	0xFE4	Interrupt enable register	0	Table 773
CLR	WO	0xFE8	Interrupt status clear register	0	Table 774
SET	WO	0xFEC	Interrupt status set register	0	Table 775

32.6.1 Control registers

32.6.1.1 QEI Control register

This register contains bits which control the operation of the position and velocity counters of the QEI module.

Table 749: QEI Control register (CON - address 0x400C 6000) bit description

Bit	Symbol	Description	Reset value
0	RESP	Reset position counter. When set = 1, resets the position counter to all zeros. Autoclears when the position counter is cleared.	0
1	RESPI	Reset position counter on index. When set = 1, resets the position counter to all zeros when an index pulse occurs. Autoclears when the position counter is cleared.	0
2	RESV	Reset velocity. When set = 1, resets the velocity counter to all zeros and reloads the velocity timer. Autoclears when the velocity counter is cleared.	0
3	RESI	Reset index counter. When set = 1, resets the index counter to all zeros. Autoclears when the index counter is cleared.	0
31:4	-	reserved	0

32.6.1.2 QEI Status register

This register provides the status of the encoder interface.

Table 750: QEI Interrupt Status register (STAT - address 0x400C 6004) bit description

Bit	Symbol	Description	Reset value
0	DIR	Direction bit. In combination with DIRINV bit indicates forward or reverse direction. See Table 778 .	
31:1	-	reserved	0

32.6.1.3 QEI Configuration register

This register contains the configuration of the QEI module.

Table 751: QEI Configuration register (CONF - address 0x400C 6008) bit description

Bit	Symbol	Description	Reset value
0	DIRINV	Direction invert. When = 1, complements the DIR bit.	0
1	SIGMODE	Signal Mode. When = 0, PhA and PhB function as quadrature encoder inputs. When = 1, PhA functions as the direction signal and PhB functions as the clock signal.	0
2	CAPMODE	Capture Mode. When = 0, only PhA edges are counted (2X). When = 1, BOTH PhA and PhB edges are counted (4X), increasing resolution but decreasing range.	0
3	INVINX	Invert Index. When set, inverts the sense of the index input.	0
4	CRESPI	Continuously reset position counter on index. When set = 1, resets the position counter to all zeros when an index pulse occurs at the next position increase (recalibration). Auto-clears when the position counter is cleared.	0
15:5	-	Reserved	0
19:16	INXGATE	Index gating configuration: when INXGATE(19)=1, pass the index when Pha=0 and Phb=0, else block. when INXGATE(18)=1, pass the index when Pha=0 and Phb=1, else block. when INXGATE(17)=1, pass the index when Pha=1 and Phb=1, else block. when INXGATE(16)=1, pass the index when Pha=1 and Phb=0, else block.	1111
31:20	-	reserved	0

32.6.2 Position, index and timer registers

32.6.2.1 QEI Position register

This register contains the current value of the encoder position. Increments or decrements when encoder counts occur, depending on the direction of rotation.

Table 752. QEI Position register (POS - address 0x400C 600C) bit description

Bit	Symbol	Description	Reset value
31:0	POS	Current position value.	0

32.6.2.2 QEI Maximum Position register

This register contains the maximum value of the encoder position. In forward rotation the position register resets to zero when the position register exceeds this value. In reverse rotation the position register resets to this value when the position register decrements from zero.

Table 753. QEI Maximum Position register (MAXPOS - address 0x400C 6010) bit description

Bit	Symbol	Description	Reset value
31:0	MAXPOS	Maximum position value.	0

32.6.2.3 QEI Position Compare register 0

This register contains a position compare value. This value is compared against the current value of the position register. Interrupts can be enabled to interrupt when the compare value is less than, equal to, or greater than the current value of the position register.

Table 754. QEI Position Compare register 0 (CMPOS0 - address 0x400C 6014) bit description

Bit	Symbol	Description	Reset value
31:0	PCMP0	Position compare value 0.	0xFFFF FFFF

32.6.2.4 QEI Position Compare register 1

This register contains a position compare value. This value is compared against the current value of the position register. Interrupts can be enabled to interrupt when the compare value is less than, equal to, or greater than the current value of the position register.

Table 755. QEI Position Compare register 1 (CMPOS1 - address 0x400C 6018) bit description

Bit	Symbol	Description	Reset value
31:0	PCMP1	Position compare value 1.	0xFFFF FFFF

32.6.2.5 QEI Position Compare register 2

This register contains a position compare value. This value is compared against the current value of the position register. Interrupts can be enabled to interrupt when the compare value is less than, equal to, or greater than the current value of the position register.

Table 756. QEI Position Compare register 2 (CMPOS2 - address 0x400C 601C) bit description

Bit	Symbol	Description	Reset value
31:0	PCMP2	Position compare value 2.	0xFFFF FFFF

32.6.2.6 QEI Index Count register

This register contains the current value of the encoder position. Increments or decrements when encoder counts occur, depending on the direction of rotation.

Table 757. QEI Index Count register (INXCNT- address 0x400C 6020) bit description

Bit	Symbol	Description	Reset value
31:0	ENCPOS	Current encoder position value.	0

32.6.2.7 QEI Index Compare register 0

This register contains an index compare value. This value is compared against the current value of the index count register. Interrupts can be enabled to interrupt when the compare value is less than, equal to, or greater than the current value of the index count register.

Table 758. QEI Index Compare register 0 (INXCMP0 - address 0x400C 6024) bit description

Bit	Symbol	Description	Reset value
31:0	ICMP0	Index compare value.	0xFFFF FFFF

32.6.2.8 QEI Timer Reload register

This register contains the reload value of the velocity timer. When the timer (TIME) reaches zero or the RESV bit is asserted, this value is loaded into the timer (TIME).

Table 759. QEI Timer Load register (LOAD - address 0x400C 6028) bit description

Bit	Symbol	Description	Reset value
31:0	VELLOAD	Current velocity timer pre-load value. The velocity timer counts down from this value.	0xFFFF FFFF

32.6.2.9 QEI Timer register

This register contains the current value of the velocity timer. When this timer reaches zero, the value of velocity register (VEL) is stored in the velocity capture register (CAP), the timer is reloaded with the value stored in the velocity reload register (LOAD), and the velocity interrupt (TIM_Int) is asserted.

Table 760. QEI Timer register (TIME - address 0x400C 602C) bit description

Bit	Symbol	Description	Reset value
31:0	VELVAL	Current velocity timer value.	0xFFFF FFFF

32.6.2.10 QEI Velocity register

This register contains the running count of velocity pulses for the current time period. When the velocity timer (TIME) reaches zero, the content of this register is captured in the velocity capture register (CAP). After capture, this register is set to zero. This register is also reset when the velocity reset bit (RESV) is asserted.

Table 761. QEI Velocity register (VEL - address 0x400C 6030) bit description

Bit	Symbol	Description	Reset value
31:0	VELPC	Current velocity pulse count.	0x0

32.6.2.11 QEI Velocity Capture register

This register contains the most recently measured velocity of the encoder. This corresponds to the number of velocity pulses counted in the previous velocity timer period. The current velocity count is latched into this register when the velocity timer overflows.

Table 762. QEI Velocity Capture register (CAP - address 0x400C 6034) bit description

Bit	Symbol	Description	Reset value
31:0	VELCAP	Velocity capture value.	0xFFFF FFFF

32.6.2.12 QEI Velocity Compare register

This register contains a velocity compare value. This value is compared against the captured velocity in the velocity capture register. If the capture velocity is less than the value in this compare register, a velocity compare interrupt (VELC_Int) will be asserted, if enabled.

Table 763. QEI Velocity Compare register (VELCOMP - address 0x400C 6038) bit description

Bit	Symbol	Description	Reset value
31:0	VELCMP	Velocity compare value.	0x0

32.6.2.13 QEI Digital filter on phase A input register

This register contains the sampling count for the digital filter. A sampling count of zero bypasses the filter.

Table 764. QEI Digital filter on phase A input register (FILTERPHA - 0x400C 603C) bit description

Bit	Symbol	Description	Reset value
31:0	FILTA	Digital filter sampling delay	0x0

32.6.2.14 QEI Digital filter on phase B input register

This register contains the sampling count for the digital filter. A sampling count of zero bypasses the filter.

Table 765. QEI Digital filter on phase B input register (FILTERPHB - 0x400C 6040) bit description

Bit	Symbol	Description	Reset value
31:0	FILTB	Digital filter sampling delay	0x0

32.6.2.15 QEI Digital filter on index input register

This register contains the sampling count for the digital filter. A sampling count of zero bypasses the filter.

Table 766. QEI Digital filter on index input register (FILTERINX - 0x400C 6044) bit description

Bit	Symbol	Description	Reset value
31:0	FITLINX	Digital filter sampling delay	0x0

32.6.2.16 QEI Index acceptance window register

This register contains the width of the index acceptance window, when the index and the phase / clock edges fall nearly together. If the activating phase / clock edge falls before the Index, but within the window, the (re)calibration will be activated on that clock/phase edge.

Table 767. QEI Index acceptance window register (WINDOW - 0x400C 6048) bit description

Bit	Symbol	Description	Reset value
31:0	WINDOW	Index acceptance window width	0x0

32.6.2.17 QEI Index Compare register 1

This register contains an index compare value. This value is compared against the current value of the index count register. Interrupts can be enabled to interrupt when the compare value is less than, equal to, or greater than the current value of the index count register.

Table 768. QEI Index Compare register 1 (INXCMP1 - address 0x400C 604C) bit description

Bit	Symbol	Description	Reset value
31:0	ICMP1	Index compare value 1.	0xFFFF FFFF

32.6.2.18 QEI Index Compare register 2

This register contains an index compare value. This value is compared against the current value of the index count register. Interrupts can be enabled to interrupt when the compare value is less than, equal to, or greater than the current value of the index count register.

Table 769. QEI Index Compare register 2 (INXCMP2 - address 0x400C 6050) bit description

Bit	Symbol	Description	Reset value
31:0	ICMP2	Index compare value 2.	0xFFFF FFFF

32.6.3 Interrupt registers

32.6.3.1 QEI Interrupt Enable Clear register

Writing a 1 to a bit in this register clears the corresponding bit in the QEI Interrupt Enable register (QEIE).

Table 770: QEI Interrupt Enable Clear register (IEC - address 0x400C 6FD8) bit description

Bit	Symbol	Description	Reset value
0	INX_EN	Indicates that an index pulse was detected.	0
1	TIM_EN	Indicates that a velocity timer overflow occurred	0
2	VELC_EN	Indicates that captured velocity is less than compare velocity.	0
3	DIR_EN	Indicates that a change of direction was detected.	0
4	ERR_EN	Indicates that an encoder phase error was detected.	0
5	ENCLK_EN	Indicates that and encoder clock pulse was detected.	0
6	POS0_INT	Indicates that the position 0 compare value is equal to the current position.	0
7	POS1_INT	Indicates that the position 1 compare value is equal to the current position.	0
8	POS2_INT	Indicates that the position 2 compare value is equal to the current position.	0
9	REV0_INT	Indicates that the index 0 compare value is equal to the current index count.	0
10	POS0REV_INT	Combined position 0 and revolution count interrupt. Set when both the POS0_INT bit is set and the REV0_Int is set.	0
11	POS1REV_INT	Combined position 1 and revolution count interrupt. Set when both the POS1_INT bit is set and the REV1_INT is set.	0
12	POS2REV_INT	Combined position 2 and revolution count interrupt. Set when both the POS2_INT bit is set and the REV2_INT is set.	0
13	REV1_INT	Indicates that the index 1 compare value is equal to the current index count.	0
14	REV2_INT	Indicates that the index 2 compare value is equal to the current index count.	0
15	MAXPOS_INT	Indicates that the current position count goes through the MAXPOS value to zero in forward direction, or through zero to MAXPOS in backward direction.	0
31:16	-	Reserved	0

32.6.3.2 QEI Interrupt Enable Set register

Writing a 1 to a bit in this register sets the corresponding bit in the QEI Interrupt Enable register (QEIE).

Table 771: QEI Interrupt Enable Set register (IES - address 0x400C 6FDC) bit description

Bit	Symbol	Description	Reset value
0	INX_EN	Indicates that an index pulse was detected.	0
1	TIM_EN	Indicates that a velocity timer overflow occurred	0
2	VELC_EN	Indicates that captured velocity is less than compare velocity.	0
3	DIR_EN	Indicates that a change of direction was detected.	0
4	ERR_EN	Indicates that an encoder phase error was detected.	0
5	ENCLK_EN	Indicates that and encoder clock pulse was detected.	0
6	POS0_INT	Indicates that the position 0 compare value is equal to the current position.	0
7	POS1_INT	Indicates that the position 1 compare value is equal to the current position.	0

Table 771: QEI Interrupt Enable Set register (IES - address 0x400C 6FDC) bit description

Bit	Symbol	Description	Reset value
8	POS2_INT	Indicates that the position 2 compare value is equal to the current position.	0
9	REV0_INT	Indicates that the index compare value is equal to the current index count.	0
10	POS0REV_INT	Combined position 0 and revolution count interrupt. Set when both the POS0_INT bit is set and the REV0_INT is set.	0
11	POS1REV_INT	Combined position 1 and revolution count interrupt. Set when both the POS1_INT bit is set and the REV1_INT is set.	0
12	POS2REV_INT	Combined position 2 and revolution count interrupt. Set when both the POS2_INT bit is set and the REV2_INT is set.	0
13	REV1_INT	Indicates that the index 1 compare value is equal to the current index count.	0
14	REV2_INT	Indicates that the index 2 compare value is equal to the current index count.	0
15	MAXPOS_INT	Indicates that the current position count goes through the MAXPOS value to zero in forward direction, or through zero to MAXPOS in backward direction.	0
31:16	-	Reserved	0

32.6.3.3 QEI Interrupt Status register

This register provides the status of the encoder interface and the current set of interrupt sources that are asserted to the controller. Bits set to 1 indicate the latched events that have occurred; a zero bit indicates that the event in question has not occurred. Writing a 0 to a bit position clears the corresponding interrupt.

Table 772: QEI Interrupt Status register (INTSTAT - address 0x400C 6FE0) bit description

Bit	Symbol	Description	Reset value
0	INX_INT	Indicates that an index pulse was detected.	0
1	TIM_INT	Indicates that a velocity timer overflow occurred	0
2	VELC_INT	Indicates that captured velocity is less than compare velocity.	0
3	DIR_INT	Indicates that a change of direction was detected.	0
4	ERR_INT	Indicates that an encoder phase error was detected.	0
5	ENCLK_INT	Indicates that an encoder clock pulse was detected.	0
6	POS0_INT	Indicates that the position 0 compare value is equal to the current position.	0
7	POS1_INT	Indicates that the position 1 compare value is equal to the current position.	0
8	POS2_INT	Indicates that the position 2 compare value is equal to the current position.	0
9	REV0_INT	Indicates that the index compare value is equal to the current index count.	0
10	POS0REV_INT	Combined position 0 and revolution count interrupt. Set when both the POS0_INT bit is set and the REV0_INT is set.	0
11	POS1REV_INT	Combined position 1 and revolution count interrupt. Set when both the POS1_INT bit is set and the REV1_INT is set.	0
12	POS2REV_INT	Combined position 2 and revolution count interrupt. Set when both the POS2_INT bit is set and the REV2_INT is set.	0
13	REV1_INT	Indicates that the index 1 compare value is equal to the current index count.	0
14	REV2_INT	Indicates that the index 2 compare value is equal to the current index count.	0
15	MAXPOS_INT	Indicates that the current position count goes through the MAXPOS value to zero in forward direction, or through zero to MAXPOS in backward direction.	0
31:16	-	Reserved	0

32.6.3.4 QEI Interrupt Enable register

This register enables interrupt sources. Bits set to 1 enable the corresponding interrupt; a 0 bit disables the corresponding interrupt.

Table 773: QEI Interrupt Enable register (IE - address 0x400C 6FE4) bit description

Bit	Symbol	Description	Reset value
0	INX_INT	Indicates that an index pulse was detected.	0
1	TIM_INT	Indicates that a velocity timer overflow occurred	0
2	VELC_INT	Indicates that captured velocity is less than compare velocity.	0
3	DIR_INT	Indicates that a change of direction was detected.	0
4	ERR_INT	Indicates that an encoder phase error was detected.	0
5	ENCLK_INT	Indicates that and encoder clock pulse was detected.	0
6	POS0_INT	Indicates that the position 0 compare value is equal to the current position.	0
7	POS1_INT	Indicates that the position 1compare value is equal to the current position.	0
8	POS2_INT	Indicates that the position 2 compare value is equal to the current position.	0
9	REV0_INT	Indicates that the index compare value is equal to the current index count.	0
10	POS0REV_INT	Combined position 0 and revolution count interrupt. Set when both the POS0_INT bit is set and the REV0_INT is set.	0
11	POS1REV_INT	Combined position 1 and revolution count interrupt. Set when both the POS1_INT bit is set and the REV1_INT is set.	0
12	POS2REV_INT	Combined position 2 and revolution count interrupt. Set when both the POS2_INT bit is set and the REV2_INT is set.	0
13	REV1_INT	Indicates that the index 1 compare value is equal to the current index count.	0
14	REV2_INT	Indicates that the index 2 compare value is equal to the current index count.	0
15	MAXPOS_INT	Indicates that the current position count goes through the MAXPOS value to zero in forward direction, or through zero to MAXPOS in backward direction.	0
31:16	-	Reserved	0

32.6.3.5 QEI Interrupt Status Clear register

Writing a 1 to a bit in this register clears the corresponding bit in the QEI Interrupt Status register (QEISTAT).

Table 774: QEI Interrupt Status Clear register (CLR - 0x400C 6FE8) bit description

Bit	Symbol	Description	Reset value
0	INX_INT	Indicates that an index pulse was detected.	0
1	TIM_INT	Indicates that a velocity timer overflow occurred	0
2	VELC_INT	Indicates that captured velocity is less than compare velocity.	0
3	DIR_INT	Indicates that a change of direction was detected.	0
4	ERR_INT	Indicates that an encoder phase error was detected.	0
5	ENCLK_INT	Indicates that and encoder clock pulse was detected.	0
6	POS0_INT	Indicates that the position 0 compare value is equal to the current position.	0
7	POS1_INT	Indicates that the position 1compare value is equal to the current position.	0
8	POS2_INT	Indicates that the position 2 compare value is equal to the current position.	0
9	REV0_INT	Indicates that the index compare value is equal to the current index count.	0

Table 774: QEI Interrupt Status Clear register (CLR - 0x400C 6FE8) bit description

Bit	Symbol	Description	Reset value
10	POS0REV_INT	Combined position 0 and revolution count interrupt. Set when both the POS0_INT bit is set and the REV0_INT is set.	0
11	POS1REV_INT	Combined position 1 and revolution count interrupt. Set when both the POS1_INT bit is set and the REV1_INT is set.	0
12	POS2REV_INT	Combined position 2 and revolution count interrupt. Set when both the POS2_INT bit is set and the REV2_INT is set.	0
13	REV1_INT	Indicates that the index 1 compare value is equal to the current index count.	0
14	REV2_INT	Indicates that the index 2 compare value is equal to the current index count.	0
15	MAXPOS_INT	Indicates that the current position count goes through the MAXPOS value to zero in forward direction, or through zero to MAXPOS in backward direction.	0
31:16	-	Reserved	0

32.6.3.6 QEI Interrupt Status Set register

Writing a one to a bit in this register sets the corresponding bit in the QEI Interrupt Status register (STAT).

Table 775: QEI Interrupt Status Set register (SET - address 0x400C 6FEC) bit description

Bit	Symbol	Description	Reset value
0	INX_INT	Indicates that an index pulse was detected.	0
1	TIM_INT	Indicates that a velocity timer overflow occurred	0
2	VELC_INT	Indicates that captured velocity is less than compare velocity.	0
3	DIR_INT	Indicates that a change of direction was detected.	0
4	ERR_INT	Indicates that an encoder phase error was detected.	0
5	ENCLK_INT	Indicates that an encoder clock pulse was detected.	0
6	POS0_INT	Indicates that the position 0 compare value is equal to the current position.	0
7	POS1_INT	Indicates that the position 1 compare value is equal to the current position.	0
8	POS2_INT	Indicates that the position 2 compare value is equal to the current position.	0
9	REV0_INT	Indicates that the index compare value is equal to the current index count.	0
10	POS0REV_INT	Combined position 0 and revolution count interrupt. Set when both the POS0_INT bit is set and the REV0_INT is set.	0
11	POS1REV_INT	Combined position 1 and revolution count interrupt. Set when both the POS1_INT bit is set and the REV1_INT is set.	0
12	POS2REV_INT	Combined position 2 and revolution count interrupt. Set when both the POS2_INT bit is set and the REV2_INT is set.	0
13	REV1_INT	Indicates that the index 1 compare value is equal to the current index count.	0
14	REV2_INT	Indicates that the index 2 compare value is equal to the current index count.	0
15	MAXPOS_INT	Indicates that the current position count goes through the MAXPOS value to zero in forward direction, or through zero to MAXPOS in backward direction.	0
31:16	-	Reserved	0

32.7 Functional description

The QEI module interprets the two-bit gray code produced by a quadrature encoder wheel to integrate position over time and determine direction of rotation. In addition, it can capture the velocity of the encoder wheel.

32.7.1 Input signals

The QEI module supports two modes of signal operation: quadrature phase mode and clock/direction mode. In quadrature phase mode, the encoder produces two clocks that are 90 degrees out of phase; the edge relationship is used to determine the direction of rotation. In clock/direction mode, the encoder produces a clock signal to indicate steps and a direction signal to indicate the direction of rotation.).

This mode is determined by the SigMode bit of the QEI Control (CON) register (See [Table 749](#)). When the SigMode bit = 1, the quadrature decoder is bypassed and the PhA pin functions as the direction signal and PhB pin functions as the clock signal for the counters, etc. When the SigMode bit = 0, the PhA pin and PhB pins are decoded by the quadrature decoder. In this mode the quadrature decoder produces the direction and clock signals for the counters, etc. In both modes the direction signal is subject to the effects of the direction invert (DIRINV) bit.

32.7.1.1 Quadrature input signals

When edges on PhA lead edges on PhB, the position counter is incremented. When edges on PhB lead edges on PhA, the position counter is decremented. When a rising and falling edge pair is seen on one of the phases without any edges on the other, the direction of rotation has changed.

Table 776. Encoder states

Phase A	Phase B	state
1	0	1
1	1	2
0	1	3
0	0	4

Table 777. Encoder state transitions^[1]

from state	to state	Direction
1	2	positive
2	3	
3	4	
4	1	
4	3	negative
3	2	
2	1	
1	4	

[1] All other state transitions are illegal and should set the ERR bit.

Interchanging of the PhA and PhB input signals are compensated by complementing the DIR bit. When set = 1, the direction inversion bit (DIRINV) complements the DIR bit.

Table 778. Encoder direction

DIR bit	DIRINV bit	direction
0	0	forward
1	0	reverse
0	1	reverse
1	1	forward

Figure 107 shows how quadrature encoder signals equate to direction and count.

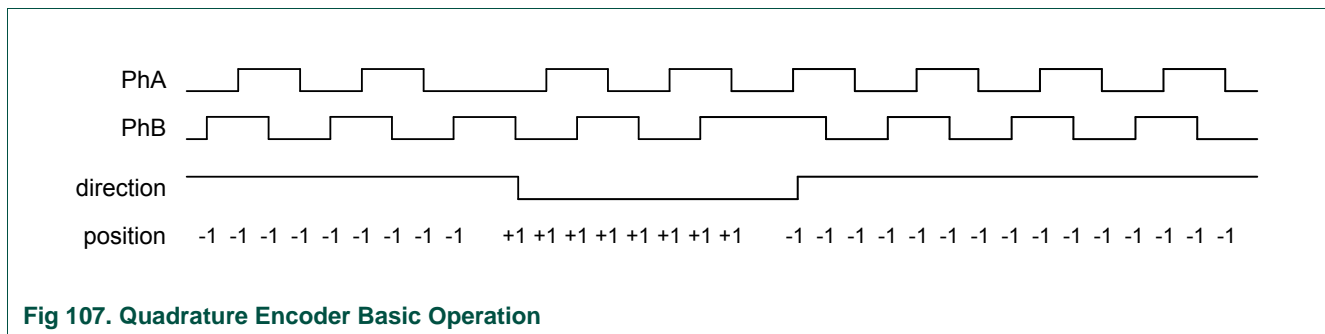

Fig 107. Quadrature Encoder Basic Operation

32.7.1.2 Digital input filtering

All three encoder inputs (PhA, PhB, and index) require digital filtering. The number of sample clocks is user programmable from 1 to 4,294,967,295 (0xFFFF FFFF). In order for a transition to be accepted, the input signal must remain in new state for the programmed number of sample clocks.

32.7.2 Position capture

The capture mode for the position integrator can be set to update the position counter on every edge of the PhA signal or to update on every edge of both PhA and PhB. Updating the position counter on every PhA and PhB provides more positional resolution at the cost of less range in the positional counter.

The position integrator and velocity capture can be independently enabled. Alternatively, the phase signals can be interpreted as a clock and direction signal as output by some encoders.

The position counter is automatically reset on one of three conditions. Incrementing past the maximum position value (MAXPOS) will reset the position counter to zero. If the reset on index bit (RESPI) is set, sensing the index pulse for the first time will once reset the position counter to zero after the next positional increase (calibrate). If the continuously reset on index bit (CRESPI) is set, sensing the index pulse will continuously reset the position counter to zero after the next positional increase (recalibrate).

32.7.3 Velocity capture

The velocity capture has a programmable timer and a capture register. It counts the number of phase edges (using the same configuration as for the position integrator) in a given time period. When the velocity timer (TIME) reaches zero, the contents of the velocity counter (VEL) are transferred to the capture (CAP) register. The velocity counter

is then cleared. The velocity timer is loaded with the contents of the velocity reload register (LOAD). Finally, the velocity interrupt (TIM_Int) is asserted. The number of edges counted in a given time period is directly proportional to the velocity of the encoder.

Setting the reset velocity bit (RESV) will clear the velocity counter, reset the velocity capture register to 0xFFFF FFFF, and load the velocity timer with the contents of the velocity reload register (LOAD).

The following equation converts the velocity counter value into an RPM value:

$$\text{RPM} = (\text{PCLK} \times \text{Speed} \times 60) / \text{Load} \times \text{PPR} \times \text{Edges}$$

where:

- PCLK is the QEI controller clock.
- PPR is the number of pulses per revolution of the physical encoder.
- Edges is 2 or 4, based on the capture mode set in the CON register (2 for CapMode set to 0 and 4 for CapMode set to 1)

For example, consider a motor running at 600 rpm. A 2048 pulse per revolution quadrature encoder is attached to the motor, producing 8192 phase edges per revolution. With clocking on both PhA and PhB edges, this results in 81,920 pulses per second (the motor turns 10 times per second). If the timer were clocked at 10,000 Hz, and the load value was 2,500 (¼ of a second), it would count 20,480 pulses per update. Using the above equation:

$$\text{RPM} = (10000 \times 20480 \times 60) / (2500 \times 2048 \times 4) = 600 \text{ RPM}$$

Now, consider that the motor is sped up to 3000 RPM. This results in 409,600 pulses per second, or 102,400 every ¼ of a second. Again, the above equation gives:

$$\text{RPM} = (10000 \times 102400 \times 60) / (2500 \times 2048 \times 4) = 3000 \text{ RPM}$$

32.7.4 Velocity compare

In addition to velocity capture, the velocity measurement system includes a programmable velocity compare register. After every velocity capture event the contents of the velocity capture register (CAP) is compared with the contents of the velocity compare register (VELCOMP). If the captured velocity is less than the compare value an interrupt is asserted provided that the velocity compare interrupt enable bit is set. This can be used to determine if a motor shaft is either stalled or moving too slow.

33.1 How to read this chapter

The RIT is available on all LPC18xx parts.

33.2 Basic configuration

The RIT is configured as follows:

- See [Table 779](#) for clocking and power control.
- The RIT is reset by the RITIMER_RST (reset #36).
- The RIT interrupt is connected to slot # 11 in the NVIC.

Table 779. RIT clocking and power control

	Base clock	Branch clock	Operating frequency
Clock to the RI timer register interface and RI timer peripheral clock (PCLK).	BASE_M3_CLK	CLK_M3_RITIMER	up to 180 MHz

33.3 Features

- 32-bit counter running from BASE_M3_CLK. Counter can be free-running or be reset by a generated interrupt.
- 32-bit compare value.
- 32-bit compare mask. An interrupt is generated when the counter value equals the compare value, after masking. This allows for combinations not possible with a simple compare.

33.4 General description

The Repetitive Interrupt Timer (RIT) provides a versatile means of generating interrupts at specified time intervals, without using a standard timer. It is intended for repeating interrupts that aren't related to Operating System interrupts. The RIT could also be used as an alternative to the Cortex-M3 System Tick Timer if there are different system requirements.

33.5.1 RI Compare Value register

Table 781. RI Compare Value register (COMPVAL - address 0x400C 0000) bit description

Bit	Symbol	Description	Reset value
31:0	RICOMP	Compare register. Holds the compare value which is compared to the counter.	0xFFFF FFFF

33.5.2 RI Mask register

Table 782. RI Mask register (MASK - address 0x400C 0004) bit description

Bit	Symbol	Description	Reset value
31:0	RIMASK	Mask register. This register holds the 32-bit mask value. A one written to any bit overrides the result of the comparison for the corresponding bit of the counter and compare register (causes the comparison of the register bits to be always true).	0

33.5.3 RI Control register

Table 783. RI Control register (CTRL - address 0x400C 0008) bit description

Bit	Symbol	Value	Description	Reset value
0	RITINT		Interrupt flag	0
		1	This bit is set to 1 by hardware whenever the counter value equals the masked compare value specified by the contents of COMPVAL and MASK registers. Writing a 1 to this bit will clear it to 0. Writing a 0 has no effect.	
		0	The counter value does not equal the masked compare value.	
1	RITENCLR		Timer enable clear	0
		1	The timer will be cleared to 0 whenever the counter value equals the masked compare value specified by the contents of COMPVAL and MASK registers. This will occur on the same clock that sets the interrupt flag.	
		0	The timer will not be cleared to 0.	
2	RITENBR		Timer enable for debug	1
		1	The timer is halted when the processor is halted for debugging.	
		0	Debug has no effect on the timer operation.	
3	RITEN		Timer enable.	1
		1	Timer enabled. Remark: This can be overruled by a debug halt if enabled in bit 2.	
		0	Timer disabled.	
31:4	-	-	Reserved, user software should not write ones to reserved bits. The value read from a reserved bit is not defined.	NA

33.5.4 RI Counter register

Table 784. RI Counter register (COUNTER - address 0x400C 000C) bit description

Bit	Symbol	Description	Reset value
31:0	RICOUNTER	32-bit up counter. Counts continuously unless RITEN bit in CTRL register is cleared or debug mode is entered (if enabled by the RITNEBR bit in CTRL). Can be loaded to any value in software.	0

33.6 RI timer operation

Following reset, the counter begins counting up from 0x0000 0000. Whenever the counter value equals the value programmed into the COMPVAL register the interrupt flag will be set. Any bit or combination of bits can be removed from this comparison (i.e. forced to compare) by writing a '1' to the corresponding bits in the MASK register. If the enable_clr bit is low (default state), a valid comparison ONLY causes the interrupt flag to be set. It has no effect on the count sequence. Counting continues as usual. When the counter reaches 0xFFFFFFFF it rolls-over to 0x000 00000 on the next clock and continues counting. If the enable_clr bit is set to '1' a valid comparison will also cause the counter to be reset to zero. Counting will resume from there on the next clock edge.

Counting can be halted in software by writing a '0' to the RITEN bit. Counting will also be halted when the processor is halted for debugging provided the RITENBR bit is set. Both the RITEN and RITENBR bits are set on reset.

The interrupt flag can be cleared in software by writing a '1' to the RITINT bit.

Software can load the counter to any value at any time by writing to COUNTER.

The counter COUNTER, COMPVAL register, MASK register and CTRL register can all be read by software at any time.

34.1 How to read this chapter

The Alarm timer is available on all LPC18xx parts.

34.2 Basic configuration

The Alarm timer is configured as follows:

- See [Table 785](#) for clocking and power control. The 32 kHz output of the 32 kHz oscillator must be enabled in the CREG0 register in the CREG block (see [Table 88](#)).
- The Alarm timer interrupt is connected to slot # 4 in the Event router.

Remark: Only write to the Alarm timer registers when the 32 kHz oscillator is running. Repeated writes to the Alarm timer registers without the 32 kHz clock can stall the CPU. To confirm that the 32 kHz clock is running, read the Alarm timer counter register (DOWNCOUNTER, see [Table 787](#)), which counts down from a preset value using the 1024 Hz clock signal derived from the 32 kHz oscillator.

Table 785. Alarm timer clocking and power control

	Base clock	Branch clock	Operating frequency
Clock to alarm timer register interface	BASE_M3_CLK	CLK_M3_BUS	up to 180 MHz
32 kHz crystal oscillator output for the counter/timer clock	-	-	1024 Hz (fixed frequency)

34.3 General description

The alarm timer is a 16-bit timer and counts down from a preset value. The counter triggers a status bit when it reaches 0x00 and asserts an interrupt if enabled.

The alarm timer operates in the RTC power domain. It consists of a 16-bit counter (DOWNCOUNTER) running at a 1024 Hz clock. The 1024 Hz clock is derived from the 32 kHz crystal clock. The alarm timer is inactive when this clock is not active.

The alarm timer counts down from an initial value PRESET. When it reaches 0x0 and the interrupt is enabled (via SET_EN), bit STATUS is triggered. The counter continues counting down starting from PRESET. The countdown period is PRESET + 1 input clock cycles.

STATUS is propagated to the interrupt output. The interrupt is connected to the Event router and can be used to wake up the device from a low power mode.

34.4 Register description

Table 786. Register overview: Alarm timer (base address 0x4004 0000)

Name	Access	Address offset	Description	Reset value	Reference
DOWNCOUNTER	R/W	0x000	Downcounter register	0x000	Table 787
PRESET	R/W	0x004	Preset value register	0x000	Table 788
-	-	0x008 - 0xFD4	Reserved	-	-
CLR_EN	W	0xFD8	Interrupt clear enable register	0x0	Table 789
SET_EN	W	0xFDC	Interrupt set enable register	0x0	Table 790
STATUS	R	0xFE0	Status register	0x0	Table 791
ENABLE	R	0xFE4	Enable register	0x0	Table 792
CLR_STAT	W	0xFE8	Clear register	0x0	Table 793
SET_STAT	W	0xFEC	Set register	0x0	Table 794

34.4.1 Downcounter register

Table 787. Downcounter register (DOWNCOUNTER - 0x4004 0000) bit description

Bit	Symbol	Description	Reset value
15:0	CVAL	When equal to zero an interrupt is raised. When equal to zero PRESET is loaded and counting continues.	0x0
31:16	-	Reserved.	-

34.4.2 Preset value register

Table 788. Preset value register (PRESET - 0x4004 0004) bit description

Bit	Symbol	Description	Reset value
15:0	PRESETVAL	Value loaded in DOWNCOUNTER when DOWNCOUNTER equals zero. Example: PRESETVAL = 0 causes an interrupt every 1/1024 s, PRESETVAL = 1 causes an interrupt every 2/1024 s, etc.	0
31:16	-	Reserved.	-

34.4.3 Interrupt clear enable register

Table 789. Interrupt clear enable register (CLR_EN - 0x4004 0FD8) bit description

Bit	Symbol	Description	Reset value
0	CLR_EN	Writing a 1 to this bit clears the interrupt enable bit in the ENABLE register.	0
31:1	-	Reserved.	-

34.4.4 Interrupt set enable register

Table 790. Interrupt set enable register (SET_EN - 0x4004 0FDC) bit description

Bit	Symbol	Description	Reset value
0	SET_EN	Writing a 1 to this bit sets the interrupt enable bit in the ENABLE register.	0
31:1	-	Reserved.	-

34.4.5 Interrupt status register

Table 791. Interrupt status register (STATUS - 0x4004 0FE0) bit description

Bit	Symbol	Description	Reset value
0	STAT	A 1 in this bit shows that the STATUS interrupt has been raised.	0
31:1	-	Reserved.	-

34.4.6 Interrupt enable register

Table 792. Interrupt enable register (ENABLE - 0x4004 0FE4) bit description

Bit	Symbol	Description	Reset value
0	EN	A 1 in this bit shows that the STATUS interrupt has been enabled and that the STATUS interrupt request signal is asserted when STAT = 1 in the STATUS register.	0
31:1	-	Reserved.	-

34.4.7 Clear status register

Table 793. Interrupt clear status register (CLR_STAT - 0x4004 0FE8) bit description

Bit	Symbol	Description	Reset value
0	CSTAT	Writing a 1 to this bit clears the STATUS interrupt bit in the STATUS register.	0
31:1	-	Reserved.	-

34.4.8 Set status register

Table 794. Interrupt set status register (SET_STAT - 0x4004 0FEC) bit description

Bit	Symbol	Description	Reset value
0	SSTAT	Writing a 1 to this bit sets the STATUS interrupt bit in the STATUS register.	0
31:1	-	Reserved.	-

35.1 How to read this chapter

The WWDT is available on all LPC18xx parts.

35.2 Basic configuration

The WWDT is configured as follows:

- See [Table 795](#) for clocking and power control. The only clock source for the WWDT clock (WDCLK) is the IRC.
- The WWDT cannot be reset by software.
- The WWDT interrupt is connected to slot # 7 in the Event router and slot #49 in the NVIC.
- The branch clock CLK_M3_WWDT must be enabled to trigger the WWDT interrupt.
- The WWDT registers can be accessed by the GPDMA as memory-to-memory transfer.

Table 795. WWDT clocking and power control

	Base clock	Branch clock	Operating frequency	Notes
Clock to WWDT register interface (PCLK)	BASE_M3_CLK	CLK_M3_WWDT	up to 180 MHz	Enable this branch clock when the WWDT is running.
Watchdog clock (WDCLK)	BASE_SAFE_CLK	-	12 MHz (fixed frequency)	-

35.3 Features

- Internally resets chip if not reloaded during the programmable time-out period.
- Optional windowed operation requires reload to occur between a minimum and maximum time-out period, both programmable.
- Optional warning interrupt can be generated at a programmable time prior to watchdog time-out.
- Programmable 24 bit timer with internal fixed pre-scaler.
- Selectable time period from 1,024 watchdog clocks ($T_{WDCLK} \times 256 \times 4$) to over 67 million watchdog clocks ($T_{WDCLK} \times 2^{24} \times 4$) in increments of 4 watchdog clocks.
- Safe watchdog operation. Once enabled, requires a hardware reset or a Watchdog reset to be disabled.
- Incorrect feed sequence causes immediate watchdog reset if enabled.
- The watchdog reload value can optionally be protected such that it can only be changed after the “warning interrupt” time is reached.

- Flag to indicate Watchdog reset.
- The WWDT uses the IRC as a fixed clock source.

35.4 Applications

The purpose of the Watchdog Timer is to reset the microcontroller within a reasonable amount of time if it enters an erroneous state. When enabled, a watchdog event will be generated if the user program fails to feed (or reload) the Watchdog within a predetermined amount of time. The Watchdog event will cause a chip reset if configured to do so.

When a watchdog window is programmed, an early watchdog feed is also treated as a watchdog event. This allows preventing situations where a system failure may still feed the watchdog. For example, application code could be stuck in an interrupt service that contains a watchdog feed. Setting the window such that this would result in an early feed will generate a watchdog event, allowing for system recovery.

35.5 Description

The Watchdog consists of a fixed divide-by-4 pre-scaler and a 24-bit counter which decrements on every clock cycle. The minimum value from which the counter decrements is 0xFF. Setting a value lower than 0xFF causes 0xFF to be loaded in the counter. Hence the minimum Watchdog interval is $(T_{WDCLK} \times 256 \times 4)$ and the maximum Watchdog interval is $(T_{WDCLK} \times 2^{24} \times 4)$ in multiples of $(T_{WDCLK} \times 4)$. The Watchdog should be used in the following manner:

- Set the Watchdog time-out value in TC register.
- Setup the Watchdog timer operating mode in MOD register.
- Set a value for the watchdog window time in WINDOW register if windowed operation is required.
- Set a compare value for the watchdog warning interrupt in the WARNINT register if a warning interrupt is required.
- Enable the Watchdog by writing 0xAA followed by 0x55 to the FEED register.
- The Watchdog must be fed again before the Watchdog counter reaches zero in order to prevent a watchdog event. If a window value is programmed, the feed must also occur after the watchdog counter passes that value.

When the Watchdog Timer is configured so that a watchdog event will cause a reset and the counter reaches zero, the CPU will be reset, loading the stack pointer and program counter from the vector table as in the case of external reset. The Watchdog time-out flag (WDTOF) can be examined to determine if the Watchdog has caused the reset condition. The WDTOF flag must be cleared by software.

When the Watchdog Timer is configured to generate a warning interrupt, the interrupt will occur when the counter matches the compare value defined by the WARNINT register.

35.5.1 WWDT behavior in Debug mode

If code execution is halted in Debug mode, the WWDT stops counting until code execution resumes.

35.5.2 WWDT behavior in the power-down modes

The WWDT is running in Sleep mode. A watchdog triggered reset in Sleep mode resets and wakes up the chip. Likewise, a watchdog triggered interrupt wakes up the chip from Sleep mode if the interrupt is enabled in the NVIC.

The WWDT is not operating in Deep-sleep, Power-down, and Deep power-down modes.

35.6 Clocking

The watchdog timer block uses two clocks: PCLK and WDCLK. PCLK is used for the APB accesses to the watchdog registers and is derived from the BASE_M3_CLK. The WDCLK is used for the watchdog timer counting and is derived from the IRC. The clock source (the IRC) is fixed to ensure that the WDT always has a valid clock.

There is some synchronization logic between these two clock domains. When the MOD and TC registers are updated by APB operations, the new value will take effect in three WDCLK cycles on the logic in the WDCLK clock domain. When the watchdog timer is counting the WDCLK clock cycles, the synchronization logic will first lock the value of the counter on WDCLK and then synchronize it with the PCLK for reading when the TV register by the CPU.

35.7 Register description

The Watchdog registers are shown in [Table 796](#).

Table 796. Register overview: Watchdog timer (base address 0x4008 0000)

Name	Access	Address offset	Description	Reset value ^[1]	Reference
MOD	R/W	0x000	Watchdog mode register. This register contains the basic mode and status of the Watchdog Timer.	0	Table 797
TC	R/W	0x004	Watchdog timer constant register. This register determines the time-out value.	0xFF	Table 799
FEED	WO	0x008	Watchdog feed sequence register. Writing 0xAA followed by 0x55 to this register reloads the Watchdog timer with the value contained in WDTC.	NA	Table 800
TV	RO	0x00C	Watchdog timer value register. This register reads out the current value of the Watchdog timer.	0xFF	Table 801
-	-	0x010	Reserved	-	-
WARNINT	R/W	0x014	Watchdog warning interrupt register. This register contains the Watchdog warning interrupt compare value.	0	Table 802
WINDOW	R/W	0x018	Watchdog timer window register. This register contains the Watchdog window value.	0xFF FFFF	Table 803

[1] Reset value reflects the data stored in used bits only. It does not include reserved bits content.

35.7.1 Watchdog mode register

The WDMOD register controls the operation of the Watchdog as per the combination of WDEN and RESET bits. Note that a watchdog feed must be performed before any changes to the WDMOD register take effect.

Table 797. Watchdog Mode register (MOD - 0x4008 0000) bit description

Bit	Symbol	Value	Description	Reset value
0	WDEN		Watchdog enable bit. This bit is Set Only.	0
		0	The watchdog timer is stopped.	
		1	The watchdog timer is running.	
1	WDRESET		Watchdog reset enable bit. This bit is Set Only.	0
		0	A watchdog time-out will not cause a chip reset.	
		1	A watchdog time-out will cause a chip reset.	
2	WDTOF		Watchdog time-out flag. Set when the watchdog timer times out, by a feed error, or by events associated with WDPROTECT, cleared by software. Causes a chip reset if WDRESET = 1. This flag is cleared by software writing a 0 to this bit.	0 (Only after external reset)
3	WDINT		Watchdog interrupt flag. Set when the timer reaches the value in the WARNINT register. Cleared by software by writing a 1 to this bit.	0
4	WDPROTECT		Watchdog update mode. This bit is Set Only.	0
		0	The watchdog time-out value (WDTC) can be changed at any time.	
		1	The watchdog time-out value (WDTC) can be changed only after the counter is below the value of WDWARNINT and WDWINDOW.	
7:5	-		Reserved, user software should not write ones to reserved bits. The value read from a reserved bit is not defined.	NA

Once the **WDEN**, **WDPROTECT**, or **WDRESET** bits are set they can not be cleared by software. Both flags are cleared by an external reset or a Watchdog timer reset.

WDTOF The Watchdog time-out flag is set when the Watchdog times out, when a feed error occurs, or when WDPROTECT =1 and an attempt is made to write to the TC register. This flag is cleared by software writing a 0 to this bit.

WDINT The Watchdog interrupt flag is set when the Watchdog counter reaches the value specified by WDWARNINT. This flag is cleared when any reset occurs, and is cleared by software by writing a 1 to this bit.

Watchdog reset or interrupt will occur any time the watchdog is running and has an operating clock source. Any clock source works in Sleep mode, and the IRC works in Deep-sleep mode. If a watchdog interrupt occurs in Sleep or Deep-sleep mode, it will wake up the device.

Table 798. Watchdog operating modes selection

WDEN	WDRESET	Mode of Operation
0	X (0 or 1)	Debug/Operate without the Watchdog running.
1	0	Watchdog interrupt mode: the watchdog warning interrupt will be generated but watchdog reset will not. When this mode is selected, the watchdog counter reaching the value specified by WDWARNINT will set the WDINT flag and the Watchdog interrupt request will be generated.
1	1	Watchdog reset mode: Both the watchdog interrupt and watchdog reset are enabled. When this mode is selected, the watchdog counter reaching the value specified by WDWARNINT will set the WDINT flag and the Watchdog interrupt request will be generated. The watchdog counter reaching zero will reset the microcontroller. Remark: Other causes for a watchdog reset are: A watchdog feed or changing the WDTC value (if the WDPROTECT bit is set in the MOD register) before reaching the value of WDWINDOW.

35.7.2 Watchdog timer constant register

The TC register determines the time-out value. Every time a feed sequence occurs, the TC register content is reloaded into the Watchdog timer. This is pre-loaded with the value 0x00 00FF upon reset. Writing values below 0xFF will cause 0x00 00FF to be loaded into the TC register. Thus the minimum time-out interval is $T_{WDCLK} \times 256 \times 4$.

If the WDPROTECT bit in MOD register is set to one, an attempt to change the value of TC before the watchdog counter is below the values of WDWARNINT and WDWINDOW will cause a watchdog reset and set the WDTOF flag.

Table 799. Watchdog Timer Constant register (TC - 0x4008 0004) bit description

Bit	Symbol	Description	Reset value
23:0	WDTC	Watchdog time-out value.	0x00 00FF
31:24	-	Reserved, user software should not write ones to reserved bits. The value read from a reserved bit is not defined.	NA

35.7.3 Watchdog feed register

Writing 0xAA followed by 0x55 to this register will reload the Watchdog timer with the time-out value in the TC register. This operation will also start the Watchdog if it is enabled via the MOD register. Setting the WDEN bit in the WDMOD register is not sufficient to enable the Watchdog. A valid feed sequence must be completed after setting WDEN before the Watchdog is capable of generating a reset. Until then, the Watchdog will ignore feed errors. After writing 0xAA to FEED register, access to any Watchdog register other than writing 0x55 to FEED register causes an immediate reset/interrupt when the Watchdog is enabled, and sets the WDTOF flag. The reset will be generated during the second PCLK following an incorrect access to a Watchdog register during a feed sequence.

Interrupts should be disabled during the feed sequence. An abort condition will occur if an interrupt happens during the feed sequence.

Table 800. Watchdog Feed register (FEED - 0x4008 0008) bit description

Bit	Symbol	Description	Reset value
7:0	Feed	Feed value should be 0xAA followed by 0x55.	NA

35.7.4 Watchdog timer value register

The WDTV register is used to read the current value of Watchdog timer counter.

When reading the value of the 24 bit counter, the lock and synchronization procedure takes up to 6 WDCLK cycles plus 6 PCLK cycles, so the value of WDTV is older than the actual value of the timer when it's being read by the CPU.

Table 801. Watchdog Timer Value register (TV - 0x4008 000C) bit description

Bit	Symbol	Description	Reset value
23:0	Count	Counter timer value.	0x00 00FF
31:24	-	Reserved, user software should not write ones to reserved bits. The value read from a reserved bit is not defined.	NA

35.7.5 Watchdog timer warning interrupt register

The WDWARNINT register determines the watchdog timer counter value that will generate a watchdog interrupt. When the watchdog timer counter matches the value defined by WDWARNINT, an interrupt will be generated after the subsequent WDCLK.

A match of the watchdog timer counter to WDWARNINT occurs when the bottom 10 bits of the counter have the same value as the 10 bits of WDWARNINT, and the remaining upper bits of the counter are all 0. This gives a maximum time of 1,023 watchdog timer counts (4,096 watchdog clocks) for the interrupt to occur prior to a watchdog event. If WDWARNINT is set to 0, the interrupt will occur at the same time as the watchdog event.

Table 802. Watchdog Timer Warning Interrupt register (WARNINT - 0x4008 0014) bit description

Bit	Symbol	Description	Reset value
9:0	WDWARNINT	Watchdog warning interrupt compare value.	0
31:10	-	Reserved, user software should not write ones to reserved bits. The value read from a reserved bit is not defined.	NA

35.7.6 Watchdog timer window register

The WDWINDOW register determines the highest WDTV value allowed when a watchdog feed is performed. If a feed valid sequence completes prior to WDTV reaching the value in WDWINDOW, a watchdog event will occur.

WDWINDOW resets to the maximum possible WDTV value, so windowing is not in effect. Values of WDWINDOW below 0x100 will make it impossible to ever feed the watchdog successfully.

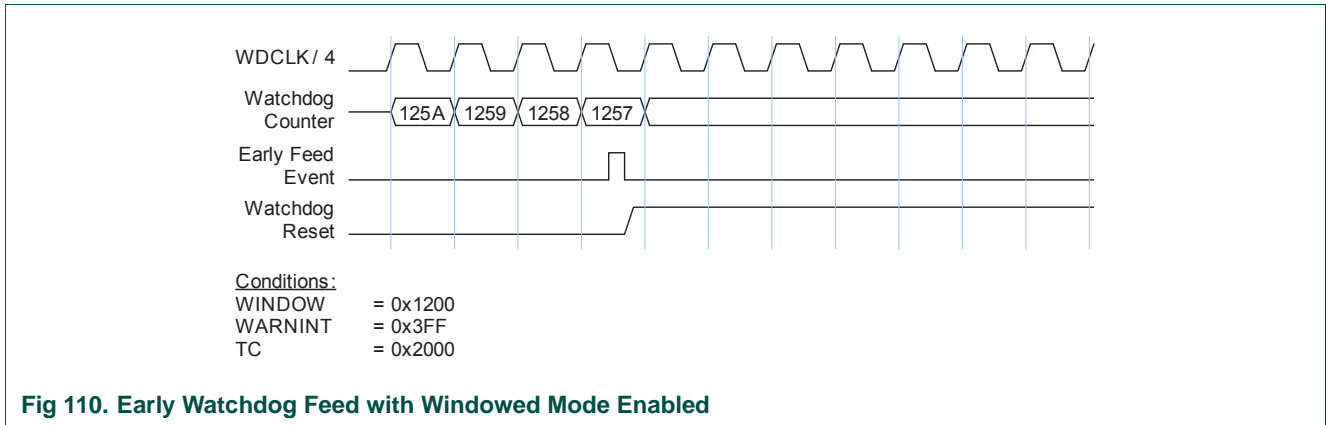

Fig 110. Early Watchdog Feed with Windowed Mode Enabled

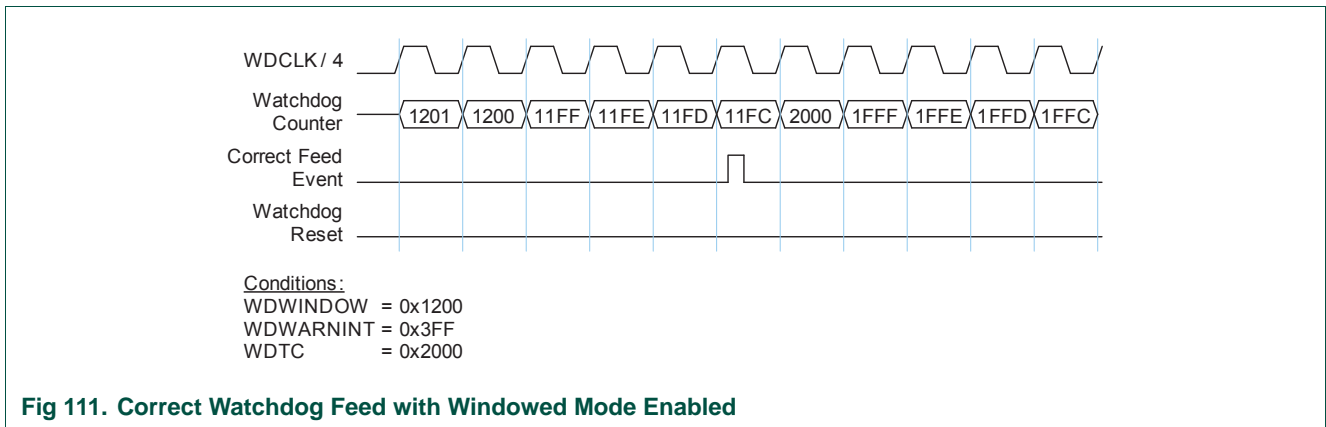

Fig 111. Correct Watchdog Feed with Windowed Mode Enabled

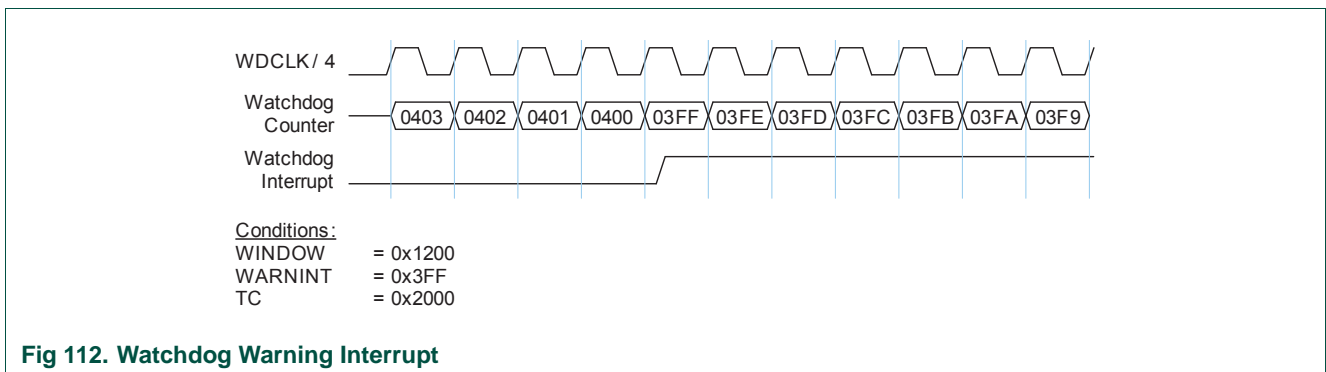

Fig 112. Watchdog Warning Interrupt

36.1 How to read this chapter

The RTC is available on all parts.

36.2 Basic configuration

The RTC is configured as follows:

- See [Table 804](#) for clocking and power control. The 1 kHz output of the 32 kHz oscillator must be enabled in the CREG0 register in the CREG block (see [Table 88](#)).
- The RTC interrupt is connected to slot # 5 in the Event router and slot #47 in the NVIC.
- The functionality of the RTC_ALARM pin is controlled by the CREG0 register (see [Table 88](#)). By default, the RTC Alarm interrupt can be monitored on this pin.

Remark: After initializing the 32 kHz oscillator, wait for 2 sec before writing to the RTC registers (see [Section 36.7.1](#)).

Remark: Only write to the RTC registers when the 32 kHz oscillator is running. Repeated writes to the RTC registers without the 32 kHz clock can stall the CPU. To confirm that the 32 kHz clock is running, read the Alarm timer counter register (DOWNCOUNTER, see [Table 787](#)), which counts down from a preset value using the 1024 Hz clock signal derived from the 32 kHz oscillator.

Table 804. RTC clocking and power control

	Base clock	Branch clock	Operating frequency
Clock to the RTC register interface	BASE_M3_CLK	CLK_M3_BUS	up to 180 MHz
32 kHz crystal oscillator output for the RTC counter/timer clock	-	-	1024 Hz (fixed frequency); the RTC receives an internal 1 Hz clock.

36.3 Features

- Measures the passage of time to maintain a calendar and clock. Provides seconds, minutes, hours, day of month, month, year, day of week, and day of year.
- Ultra-low power design to support battery powered systems. Uses power from the CPU power supply when it is present.
- Dedicated battery power supply pin.
- RTC power supply is isolated from the rest of the chip.
- Calibration counter allows adjustment to better than ± 1 sec/day with 1 sec resolution.
- Periodic interrupts can be generated from increments of any field of the time registers and selected fractional second values.
- An alarm interrupt can be generated for a specific date/time.

36.4 General description

The Real Time Clock (RTC) is a set of counters for measuring time when system power is on, and optionally when it is off. It uses very little power when its registers are not being accessed by the CPU, especially in reduced power modes. On the LPC18xx, the RTC is clocked by a separate 32 kHz oscillator that produces a 1 Hz internal time reference. The RTC is powered by its own power supply pin, VBAT.

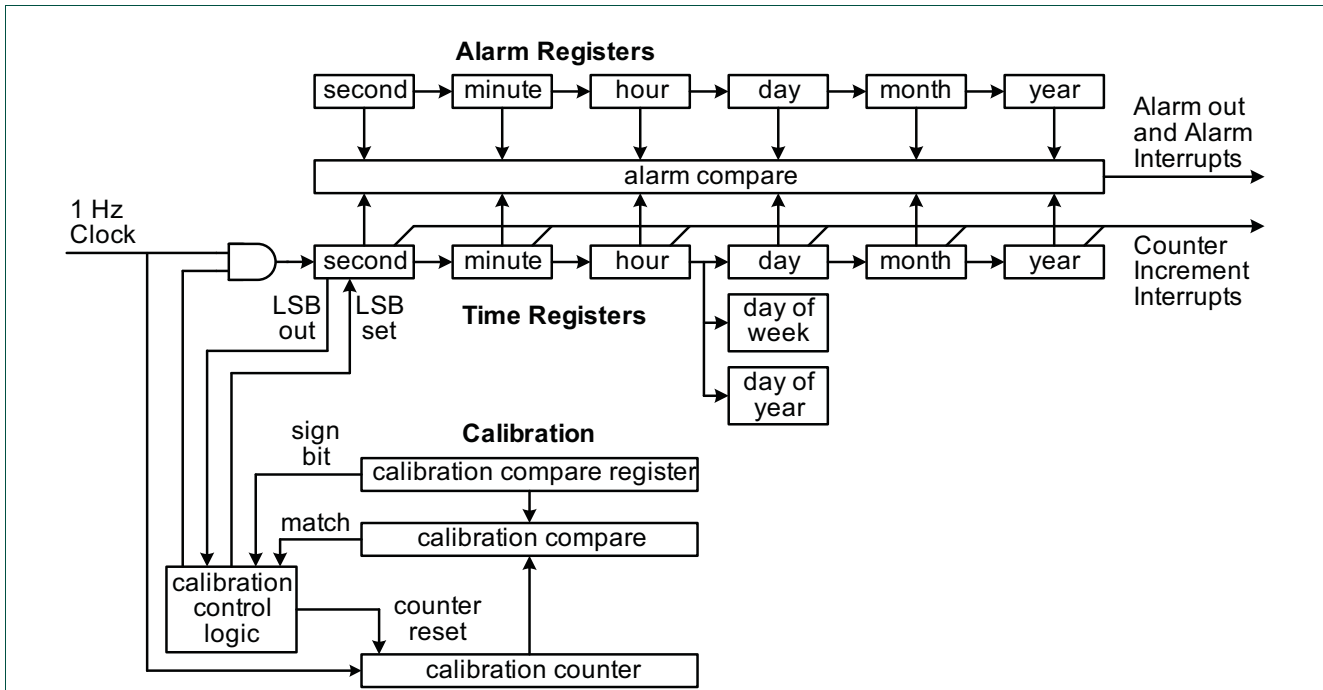

Fig 113. RTC functional block diagram

36.5 Pin description

Table 805. RTC pin description

Pin function	Direction	Description
RTC_ALARM	O	RTC controlled output. The pin goes HIGH when an RTC alarm is generated. CREG0 bits ALARMCTRL must be set to 0.(see Table 88).

36.6 Register description

Table 806. Register overview: RTC (base address 0x4004 6000)

Name	Access	Address offset	Description	Reset value	Reference
ILR	W	0x000	Interrupt Location Register	0x0	Table 808
-	-	0x004	Reserved	0x00	-
CCR	R/W	0x008	Clock Control Register	0x00	Table 809
CIIR	R/W	0x00C	Counter Increment Interrupt Register	0x00	Table 810
AMR	R/W	0x010	Alarm Mask Register	-[1]	Table 811
CTIME0	R	0x014	Consolidated Time Register 0	-[1]	Table 812
CTIME1	R	0x018	Consolidated Time Register 1	-[1]	Table 813
CTIME2	R	0x01C	Consolidated Time Register 2	-[1]	Table 814
SEC	R/W	0x020	Seconds Register	-[1]	Table 817
MIN	R/W	0x024	Minutes Register	-[1]	Table 818
HRS	R/W	0x028	Hours Register	-[1]	Table 819
DOM	R/W	0x02C	Day of Month Register	-[1]	Table 820
DOW	R/W	0x030	Day of Week Register	-[1]	Table 821
DOY	R/W	0x034	Day of Year Register	-[1]	Table 822
MONTH	R/W	0x038	Months Register	-[1]	Table 823
YEAR	R/W	0x03C	Years Register	-[1]	Table 824
CALIBRATION	R/W	0x040	Calibration Value Register	-[1]	Table 825
-	-	0x044 - 0x05C		-	-
ASEC	R/W	0x060	Alarm Seconds Register	-[1]	Table 827
AMIN	R/W	0x064	Alarm Minutes Register	-[1]	Table 828
AHRS	R/W	0x068	Alarm Hours Register	-[1]	Table 829
ADOM	R/W	0x6C	Alarm Day of Month Register	-[1]	Table 830
ADOW	R/W	0x070	Alarm Day of Week Register	-[1]	Table 831
ADOY	R/W	0x074	Alarm Day of Year Register	-[1]	Table 832
AMON	R/W	0x078	Alarm Month Register	-[1]	Table 833
AYRS	R/W	0x07C	Alarm Year Register	-[1]	Table 834

[1] This register value is not changed by reset.

In addition to the RTC registers, 64 general purpose registers are available to store data when the main power supply is switched off. The general purpose registers reside in the RTC power domain and can be battery powered.

Table 807. Register overview: REGFILE (base address 0x4004 1000)

Name	Access	Address offset	Description	Reset Value
REGFILE0	R/W	0x000	General purpose storage register	0x0
to				
REGFILE63	R/W	0x0FC	General purpose storage register	0x0

36.6.1 Interrupt Location Register

The Interrupt Location Register is a 2-bit register that specifies which blocks are generating an interrupt. Writing a one to the appropriate bit clears the corresponding interrupt. Writing a zero has no effect. This allows the programmer to read this register and write back the same value to clear only the interrupt that is detected by the read.

Table 808. Interrupt Location Register (ILR - address 0x4004 6000) bit description

Bit	Symbol	Description	Reset value
0	RTCCIF	When one, the Counter Increment Interrupt block generated an interrupt. Writing a one to this bit location clears the counter increment interrupt.	0
1	RTCALF	When one, the alarm registers generated an interrupt. Writing a one to this bit location clears the alarm interrupt.	0
31:2	-	Reserved, user software should not write ones to reserved bits. The value read from a reserved bit is not defined.	NA

36.6.2 Clock Control Register

The clock register is a 4-bit register that controls the operation of the clock divide circuit. Bits 0, 1, and 4 in this register should be initialized when the RTC is first turned on.

Table 809. Clock Control Register (CCR - address 0x4004 6008) bit description

Bit	Symbol	Value	Description	Reset value
0	CLKEN		Clock Enable.	[1]
		0	The time counters are disabled so that they may be initialized.	
		1	The time counters are enabled.	
1	CTCRST		CTC Reset.	0
		0	No effect.	
	1	When one, the elements in the internal oscillator divider are reset, and remain reset until this bit is changed to zero. This is the divider that generates the 1 Hz clock from the 32.768 kHz crystal. The state of the divider is not visible to software.		
3:2	-		Internal test mode controls. These bits must be 0 for normal RTC operation.	[1]
4	CCALEN		Calibration counter enable.	[1]
		0	The calibration counter is enabled and counting, using the 1 Hz clock. When the calibration counter is equal to the value of the CALIBRATION register, the counter resets and repeats counting up to the value of the CALIBRATION register. See Section 36.6.6.2 and Section 36.7.2 .	
		1	The calibration counter is disabled and reset to zero.	
31:5	-		Reserved, user software should not write ones to reserved bits. The value read from a reserved bit is not defined.	NA

[1] This register value is not changed by reset.

36.6.3 Counter Increment Interrupt Register

The Counter Increment Interrupt Register (CIIR) gives the ability to generate an interrupt every time a counter is incremented. This interrupt remains valid until cleared by writing a 1 to bit 0 of the Interrupt Location Register (ILR[0]).

Table 810. Counter Increment Interrupt Register (CIIR - address 0x4004 600C) bit description

Bit	Symbol	Description	Reset value
0	IMSEC	When 1, an increment of the Second value generates an interrupt.	0
1	IMMIN	When 1, an increment of the Minute value generates an interrupt.	0
2	IMHOUR	When 1, an increment of the Hour value generates an interrupt.	0
3	IMDOM	When 1, an increment of the Day of Month value generates an interrupt.	0
4	IMDOW	When 1, an increment of the Day of Week value generates an interrupt.	0
5	IMDOY	When 1, an increment of the Day of Year value generates an interrupt.	0
6	IMMON	When 1, an increment of the Month value generates an interrupt.	0
7	IMYEAR	When 1, an increment of the Year value generates an interrupt.	0
31:8	-	Reserved, user software should not write ones to reserved bits. The value read from a reserved bit is not defined.	NA

36.6.4 Alarm Mask Register

The Alarm Mask Register (AMR) allows the user to mask any of the alarm registers. [Table 811](#) shows the relationship between the bits in the AMR and the alarms. For the alarm function, every non-masked alarm register must match the corresponding time counter for an interrupt to be generated. The interrupt is generated only when the counter comparison first changes from no match to match. The interrupt is removed when a one is written to the appropriate bit of the Interrupt Location Register (ILR). If all mask bits are set, then the alarm is disabled.

Table 811. Alarm Mask Register (AMR - address 0x4004 6010) bit description

Bit	Symbol	Description	Reset value
0	AMRSEC	When 1, the Second value is not compared for the alarm.	0
1	AMRMIN	When 1, the Minutes value is not compared for the alarm.	0
2	AMRHOUR	When 1, the Hour value is not compared for the alarm.	0
3	AMRDOM	When 1, the Day of Month value is not compared for the alarm.	0
4	AMRDOW	When 1, the Day of Week value is not compared for the alarm.	0
5	AMRDOY	When 1, the Day of Year value is not compared for the alarm.	0
6	AMRMON	When 1, the Month value is not compared for the alarm.	0
7	AMRYEAR	When 1, the Year value is not compared for the alarm.	0
31:8	-	Reserved, user software should not write ones to reserved bits. The value read from a reserved bit is not defined.	NA

36.6.5 Consolidated time registers

The values of the Time Counters can optionally be read in a consolidated format which allows the programmer to read all time counters with only three read operations. The various registers are packed into 32-bit values as shown in [Table 812](#), [Table 813](#), and [Table 814](#). The least significant bit of each register is read back at bit 0, 8, 16, or 24.

The Consolidated Time Registers are read-only. To write new values to the Time Counters, the Time Counter addresses should be used.

36.6.5.1 Consolidated Time Register 0

The Consolidated Time Register 0 contains the low order time values: Seconds, Minutes, Hours, and Day of Week.

Table 812. Consolidated Time register 0 (CTIME0 - address 0x4004 6014) bit description

Bit	Symbol	Description	Reset value
5:0	SECONDS	Seconds value in the range of 0 to 59	-[1]
7:6	-	Reserved, user software should not write ones to reserved bits. The value read from a reserved bit is not defined.	-
13:8	MINUTES	Minutes value in the range of 0 to 59	-[1]
15:14	-	Reserved, user software should not write ones to reserved bits. The value read from a reserved bit is not defined.	-
20:16	HOURS	Hours value in the range of 0 to 23	-[1]
23:21	-	Reserved, user software should not write ones to reserved bits. The value read from a reserved bit is not defined.	-[1]
26:24	DOW	Day of week value in the range of 0 to 6	-[1]
31:27	-	Reserved, user software should not write ones to reserved bits. The value read from a reserved bit is not defined.	-

[1] This register value is not changed by reset.

36.6.5.2 Consolidated Time Register 1

The Consolidate Time Register 1 contains the Day of Month, Month, and Year values.

Table 813. Consolidated Time register 1 (CTIME1 - address 0x4004 6018) bit description

Bit	Symbol	Description	Reset value
4:0	DOM	Day of month value in the range of 1 to 28, 29, 30, or 31 (depending on the month and whether it is a leap year).	-[1]
7:5	-	Reserved, user software should not write ones to reserved bits. The value read from a reserved bit is not defined.	-
11:8	MONTH	Month value in the range of 1 to 12.	-[1]
15:12	-	Reserved, user software should not write ones to reserved bits. The value read from a reserved bit is not defined.	-
27:16	YEAR	Year value in the range of 0 to 4095.	-[1]
31:28	-	Reserved, user software should not write ones to reserved bits. The value read from a reserved bit is not defined.	-

[1] This register value is not changed by reset.

36.6.5.3 Consolidated Time Register 2

The Consolidate Time Register 2 contains just the Day of Year value.

Table 814. Consolidated Time register 2 (CTIME2 - address 0x4004 601C) bit description

Bit	Symbol	Description	Reset value
11:0	DOY	Day of year value in the range of 1 to 365 (366 for leap years).	- ^[1]
31:12	-	Reserved, user software should not write ones to reserved bits. The value read from a reserved bit is not defined.	-

[1] This register value is not changed by reset.

36.6.6 Time Counter Group

The time value consists of the eight counters shown in [Table 815](#) and [Table 816](#). These counters can be read or written at the locations shown in [Table 816](#).

Table 815. Time Counter relationships and values

Counter	Size	Enabled by	Minimum value	Maximum value
Second	6	1 Hz Clock	0	59
Minute	6	Second	0	59
Hour	5	Minute	0	23
Day of Month	5	Hour	1	28, 29, 30 or 31
Day of Week	3	Hour	0	6
Day of Year	9	Hour	1	365 or 366 (for leap year)
Month	4	Day of Month	1	12
Year	12	Month or day of Year	0	4095

Table 816. Time Counter registers

Name	Size	Description	Access	Address
SEC	6	Seconds value in the range of 0 to 59	R/W	0x4004 6020
MIN	6	Minutes value in the range of 0 to 59	R/W	0x4004 6024
HRS	5	Hours value in the range of 0 to 23	R/W	0x4004 6028
DOM	5	Day of month value in the range of 1 to 28, 29, 30, or 31 (depending on the month and whether it is a leap year). ^[1]	R/W	0x4004 602C
DOW	3	Day of week value in the range of 0 to 6 ^[1]	R/W	0x4004 6030
DOY	9	Day of year value in the range of 1 to 365 (366 for leap years) ^[1]	R/W	0x4004 6034
MONTH	4	Month value in the range of 1 to 12	R/W	0x4004 6038
YEAR	12	Year value in the range of 0 to 4095	R/W	0x4004 603C

[1] These values are simply incremented at the appropriate intervals and reset at the defined overflow point. They are not calculated and must be correctly initialized in order to be meaningful.

Table 817. Seconds register (SEC - address 0x4004 6020) bit description

Bit	Symbol	Description	Reset value
5:0	SECONDS	Seconds value in the range of 0 to 59	-[1]
31:6	-	Reserved, user software should not write ones to reserved bits. The value read from a reserved bit is not defined.	-

[1] This register value is not changed by reset.

Table 818. Minutes register (MIN - address 0x4004 6024) bit description

Bit	Symbol	Description	Reset value
5:0	MINUTES	Minutes value in the range of 0 to 59	-[1]
31:6	-	Reserved, user software should not write ones to reserved bits. The value read from a reserved bit is not defined.	-

[1] This register value is not changed by reset.

Table 819. Hours register (HRS - address 0x4004 6028) bit description

Bit	Symbol	Description	Reset value
4:0	HOURS	Hours value in the range of 0 to 23	-[1]
31:5	-	Reserved, user software should not write ones to reserved bits. The value read from a reserved bit is not defined.	-

[1] This register value is not changed by reset.

Table 820. Day of month register (DOM - address 0x4004 602C) bit description

Bit	Symbol	Description	Reset value
4:0	DOM	Day of month value in the range of 1 to 28, 29, 30, or 31 (depending on the month and whether it is a leap year).	-[1]
31:5	-	Reserved, user software should not write ones to reserved bits. The value read from a reserved bit is not defined.	-

[1] This register value is not changed by reset.

Table 821. Day of week register (DOW - address 0x4004 6030) bit description

Bit	Symbol	Description	Reset value
2:0	DOW	Day of week value in the range of 0 to 6.	-[1]
31:3	-	Reserved, user software should not write ones to reserved bits. The value read from a reserved bit is not defined.	-

[1] This register value is not changed by reset.

Table 822. Day of year register (DOY - address 0x4004 6034) bit description

Bit	Symbol	Description	Reset value
8:0	DOY	Day of year value in the range of 1 to 365 (366 for leap years).	-[1]
31:9	-	Reserved, user software should not write ones to reserved bits. The value read from a reserved bit is not defined.	-

[1] This register value is not changed by reset.

Table 823. Month register (MONTH - address 0x4004 6038) bit description

Bit	Symbol	Description	Reset value
3:0	MONTH	Month value in the range of 1 to 12.	-[1]
31:4	-	Reserved, user software should not write ones to reserved bits. The value read from a reserved bit is not defined.	-

[1] This register value is not changed by reset.

Table 824. Year register (YEAR - address 0x4004 603C) bit description

Bit	Symbol	Description	Reset value
11:0	YEAR	Year value in the range of 0 to 4095.	-[1]
31:12	-	Reserved, user software should not write ones to reserved bits. The value read from a reserved bit is not defined.	-

[1] This register value is not changed by reset.

36.6.6.1 Leap year calculation

The RTC does a simple bit comparison to see if the two lowest order bits of the year counter are zero. If true, then the RTC considers that year a leap year. The RTC considers all years evenly divisible by 4 as leap years. This algorithm is accurate from the year 1901 through the year 2099, but fails for the year 2100, which is not a leap year. The only effect of leap year on the RTC is to alter the length of the month of February for the month, day of month, and year counters.

36.6.6.2 Calibration register

The following register is used to calibrate the time counter. The bits in this register are not changed by reset.

Table 825. Calibration register (CALIBRATION - address 0x4004 6040) bit description

Bit	Symbol	Value	Description	Reset value
16:0	CALVAL	-	If enabled, the calibration counter counts up to this value. The maximum value is 131072 corresponding to about 36.4 hours. Calibration is disabled if CALVAL = 0.	-[1]

Table 825. Calibration register (CALIBRATION - address 0x4004 6040) bit description

Bit	Symbol	Value	Description	Reset value
17	CALDIR		Calibration direction	-[1]
		0	Forward calibration. When CALVAL is equal to the calibration counter, the RTC timers will jump by 2 seconds.	
		1	Backward calibration. When CALVAL is equal to the calibration counter, the RTC timers will stop incrementing for 1 second.	
31:18	-		Reserved, user software should not write ones to reserved bits. The value read from a reserved bit is not defined.	-

[1] This register value is not changed by reset.

36.6.7 Alarm register group

The alarm registers are shown in [Table 826](#). The values in these registers are compared with the time counters. If all the unmasked (See [Section 36.6.4 “Alarm Mask Register” on page 994](#)) alarm registers match their corresponding time counters then an interrupt is generated. The interrupt is cleared when a 1 is written to bit 1 of the Interrupt Location Register (ILR[1]).

Table 826. Alarm registers

Name	Size	Description	Access	Address
ALSEC	6	Alarm value for Seconds	R/W	0x4004 6060
ALMIN	6	Alarm value for Minutes	R/W	0x4004 6064
ALHRS	5	Alarm value for Hours	R/W	0x4004 6068
ALDOM	5	Alarm value for Day of Month	R/W	0x4004 606C
ALDOW	3	Alarm value for Day of Week	R/W	0x4004 6070
ALDOY	9	Alarm value for Day of Year	R/W	0x4004 6074
ALMON	4	Alarm value for Months	R/W	0x4004 6078
ALYEAR	12	Alarm value for Years	R/W	0x4004 607C

Table 827. Alarm Seconds register (ASEC - address 0x4004 6060) bit description

Bit	Symbol	Description	Reset value
5:0	SECONDS	Seconds value in the range of 0 to 59	-[1]
31:6	-	Reserved, user software should not write ones to reserved bits. The value read from a reserved bit is not defined.	-

[1] This register value is not changed by reset.

Table 828. Alarm Minutes register (AMIN - address 0x4004 6064) bit description

Bit	Symbol	Description	Reset value
5:0	MINUTES	Minutes value in the range of 0 to 59	-[1]
31:6	-	Reserved, user software should not write ones to reserved bits. The value read from a reserved bit is not defined.	-

[1] This register value is not changed by reset.

Table 829. Alarm Hours register (AHRS - address 0x4004 6068) bit description

Bit	Symbol	Description	Reset value
4:0	HOURS	Hours value in the range of 0 to 23	-[1]
31:5	-	Reserved, user software should not write ones to reserved bits. The value read from a reserved bit is not defined.	-

[1] This register value is not changed by reset.

Table 830. Alarm Day of month register (ADOM - address 0x4004 606C) bit description

Bit	Symbol	Description	Reset value
4:0	DOM	Day of month value in the range of 1 to 28, 29, 30, or 31 (depending on the month and whether it is a leap year).	-[1]
31:5	-	Reserved, user software should not write ones to reserved bits. The value read from a reserved bit is not defined.	-

[1] This register value is not changed by reset.

Table 831. Alarm Day of week register (ADOW - address 0x4004 6070) bit description

Bit	Symbol	Description	Reset value
2:0	DOW	Day of week value in the range of 0 to 6.	-[1]
31:3	-	Reserved, user software should not write ones to reserved bits. The value read from a reserved bit is not defined.	-

[1] This register value is not changed by reset.

Table 832. Alarm Day of year register (ADOY - address 0x4004 6074) bit description

Bit	Symbol	Description	Reset value
8:0	DOY	Day of year value in the range of 1 to 365 (366 for leap years).	-[1]
31:9	-	Reserved, user software should not write ones to reserved bits. The value read from a reserved bit is not defined.	-

[1] This register value is not changed by reset.

Table 833. Alarm Month register (AMON - address 0x4004 6078) bit description

Bit	Symbol	Description	Reset value
3:0	MONTH	Month value in the range of 1 to 12.	-[1]
31:4	-	Reserved, user software should not write ones to reserved bits. The value read from a reserved bit is not defined.	-

[1] This register value is not changed by reset.

Table 834. Alarm Year register (AYRS - address 0x4004 607C) bit description

Bit	Symbol	Description	Reset value
11:0	YEAR	Year value in the range of 0 to 4095.	[1]
31:12	-	Reserved, user software should not write ones to reserved bits. The value read from a reserved bit is not defined.	-

[1] This register value is not changed by reset.

36.7 Functional description

36.7.1 Register read procedure

The RTC uses two clocks, the bus interface clock (CLK_M3_BUS) for register access and the 1 Hz clock provided by the RTCOSC in the battery powered low-power domain.

Writing data potentially takes up to 1.5 clock cycles of the 1 Hz clock to be captured in the low-power domain. When reading, the registers reflect the actual content with a 0.5 clock cycle delay of the 1 Hz clock, so the previously written data can show up to 2 clock cycles of the 1 Hz clock later.

To read the correct register content, poll the last written register until it shows the new value to ensure that the correct value has been captured. All earlier writes are also captured at this point in time.

Within one second after a wake-up from a low power mode, the read values may be incorrect. This can be resolved by either re-reading the register more than 1 sec after wake-up or by reading the value until it has changed.

36.7.2 Calibration procedure

The calibration logic can periodically adjust the time counter either by not incrementing the counter, or by incrementing the counter by 2 instead of 1. This allows calibrating the RTC oscillator under some typical voltage and temperature conditions without the need to externally trim the RTC oscillator.

A recommended method for determining the calibration value is to use the CLKOUT feature to unintrusively observe the RTC oscillator frequency under the conditions it is to be trimmed for, and calculating the number of clocks that will be seen before the time is off by one second. That value is used to determine CALVAL.

The exact method of calibration depends on whether CALVAL is even or odd. For even values, the hardware performs a two calibrations sequentially multiple times (one calibration at CALVAL+1 and one calibration at CALVAL - 1) and averages both calibration values. For odd values of CALVAL, the calibration time is accurate.

If the RTC oscillator is trimmed externally, the same method of unintrusively observing the RTC oscillator frequency may be helpful in that process.

Backward calibration

Enable the RTC timer and calibration in the CCR register (set bits CLKEN = 1 and CCALEN = 0). In the CALIBRATION register, set the calibration value CALVAL \geq 1 and select CALDIR = 1.

- The SEC timer and the calibration counter count up for every 1 Hz clock cycle.
- When the calibration counter reaches CALVAL, a calibration match occurs and all RTC timers will be stopped for one clock cycle so that the timers will not increment in the next cycle.
- If an alarm match event occurs in the same cycle as the calibration match, the alarm interrupt will be delayed by one cycle to avoid a double alarm interrupt.

Forward calibration

Enable the RTC timer and calibration in the CCR register (set bits CLKEN = 1 and CCALEN = 0). In the CALIBRATION register, set the calibration value $CALVAL \geq 1$ and select CALDIR = 0.

- The SEC timer and the calibration counter count up for every 1 Hz clock cycle.
- When the calibration counter reaches CALVAL, a calibration match occurs and the RTC timers are incremented by 2.
- When the calibration event occurs, the LSB of the ALSEC register is forced to be one so that the alarm interrupt will not be missed when skipping a second.

37.1 How to read this chapter

The event monitor/recorder is available on parts with on-chip flash only.

37.2 Basic configuration

The event monitor/recorder is configured together with the RTC:

- See [Table 835](#) for clocking and power control. The 1 kHz output of the 32 kHz oscillator must be enabled in the CREG0 register in the CREG block (see [Table 88](#)).
- The event monitor/recorder raises an RTC interrupt which is connected to slot # 5 in the Event router and slot #47 in the NVIC.
- Enable the $\overline{\text{SAMPLE}}$ pin for monitoring the sample clock in the CREG0 register (see [Table 88](#)).

Table 835. RTC clocking and power control

	Base clock	Branch clock	Operating frequency
Clock to the RTC and event monitor/router register interface	BASE_M3_CLK	CLK_M3_BUS	up to 180 MHz
32 kHz crystal oscillator output for the RTC counter/timer clock	-	-	1024 Hz (fixed frequency); the RTC receives an internal 1 Hz clock.

37.3 Features

- Supports three digital event inputs in the RTC power domain.
- An event is a level change at the digital event inputs.
- For each event channel, two timestamps mark the first and the last occurrence of an event. Each channel also has a dedicated counter tracking the total number of events. Timestamp values are taken from the RTC.
- Runs in RTC power domain, independent of system power supply.
- Can run in Deep Power Down mode if VBAT is present.
- Very low-power consumption.
- Interrupt available if system is up.
- A qualified event can be used as a wake-up trigger.
- State of event inputs accessible by software through general purpose I/O.

37.4 Applications

The event monitor/recorder is used to record tampering events in sealed product enclosures. Sensors report any attempt to open the enclosure, or to tamper with the device in any other way. The primary purpose of the Event Monitor/Recorder is to store records of such events when the device is powered only by the backup battery.

37.5 General description

The Event Monitor/Recorder relies on VBAT to be present at all times. A loss or dip of VBAT voltage causes the Real-Time Clock power fail detector to reset the event recordings. It is therefore important to have a VBAT power source that can deliver power for the longest expected mains power outage.

Once system power is restored, the CPU can check for recorded tamper events. If there were tamper events, the timestamp registers for the first and the last event would indicate the period over which they occurred.

An edge on an event input is sampled with either a 1 kHz clock, a 64 Hz clock, or a 16 Hz clock. A transition in either direction must be captured by two successive edges of this clock in order to be recognized as a valid transition. This provides a 1-2 ms rejection filter in case of the 1 kHz sample clock, a 15.6-31.2 ms rejection filter in case of the 64 Hz sample clock, and a 62.5-125ms rejection filter in case of the 16 Hz sample clock. Such an event will set the EVx bit in the ERSTATUS register on the next rising edge of the 1 Hz clock.

If an event occurs, a timestamp will be taken from the RTC and stored in the ERLASTSTAMPx register. This timestamp will be updated with every new event. The event will also update the ERFIRSTSTAMPx register if this is the first event to occur since the last time the EVx bit in the status register was cleared.

In addition to taking the timestamp(s), a 3-bit counter (ERCOUNTERx) will be incremented on the rising edge of the 1 Hz clock (i.e. coincident with the ERLASTSTAMPx register being updated). The counter stops counting and holds when it reaches a count of seven. It will be cleared automatically when the software clears the EVx bit in the status register.

An event can be enabled to clear the backup registers in the RTC block asynchronously. This works even when the 32 kHz oscillator is not running or when Event Monitor/Recorder clocks are disabled.

The following figure shows a block diagram of the Event Monitor/Recorder.

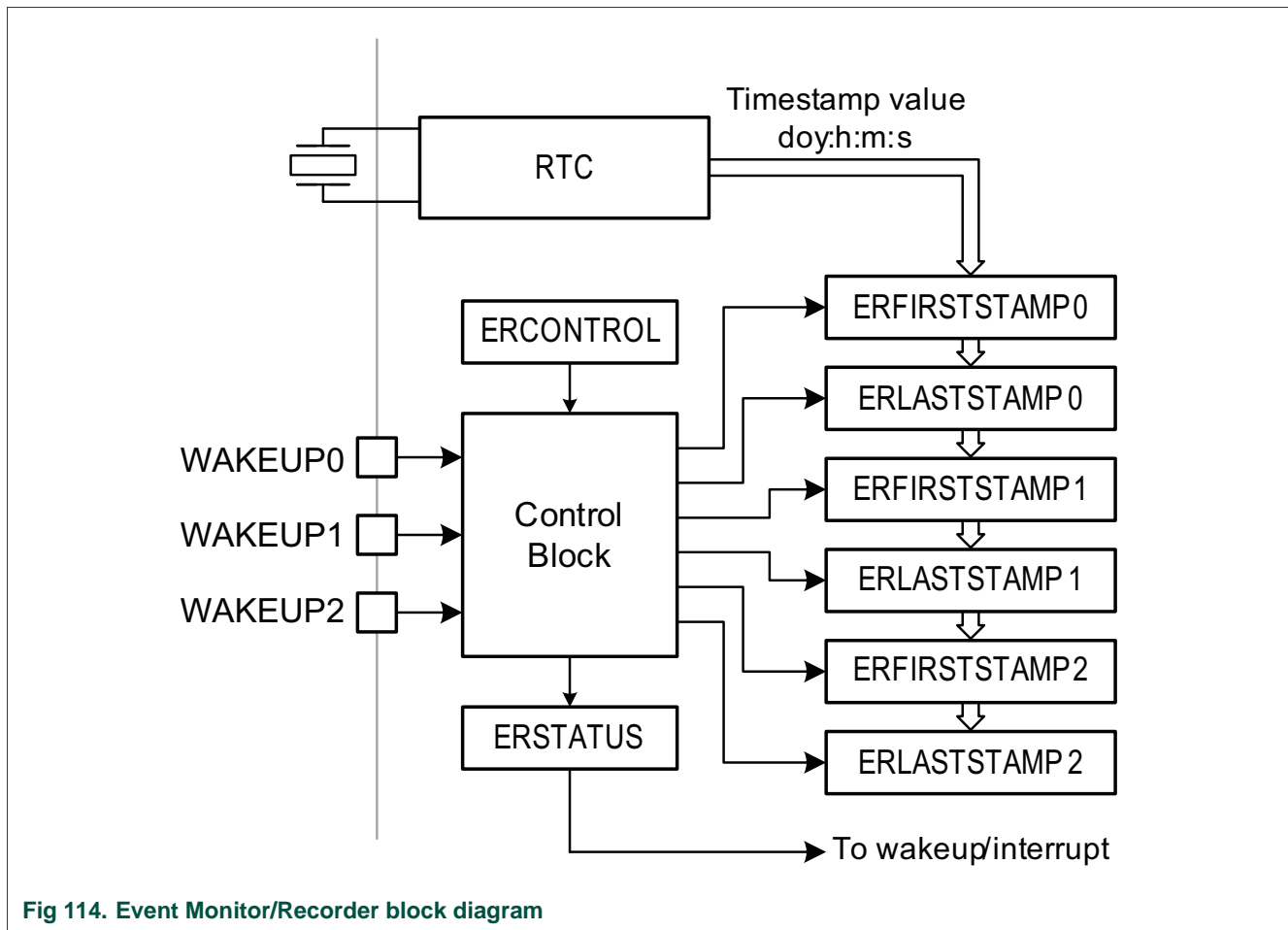

Fig 114. Event Monitor/Recorder block diagram

The CPU may at any time check the ERSTATUS register for events. If, for instance the EV0 bit is set, the corresponding ERFIRSTSTAMP0 and ERLASTSTAMP0 registers contain valid timestamps. The ERCOUNTER0 will also contain a valid count of the total number of events on channel 0 (up to a maximum of seven).

Once the (private) timestamps have been read, the CPU can clear the ERSTATUS.EVx bits by writing a 1 to it.

The CPU should ignore the timestamp registers if the ERSTATUS.EVx bit is cleared. There is no mechanism to clear or invalidate the timestamps after the event flag in the status register has been cleared. The timestamp registers will keep their old values until a new qualified event updates them. Such a qualified event will set the ERSTATUS.EVx bit and inform the CPU that the timestamp registers contain new values.

An event channel can be qualified as a wake-up trigger signal by setting the INTWAKE_ENAx bit in the ERCONTROL register. An event in that channel will then wake up the device from a power saving mode.

37.6 Pin description

Table 836. Event Monitor/Recorder pin description

Name	Type	Description
WAKEUP0	Input	Event input for event monitor/recorder channel 0.
WAKEUP1	Input	Event input for event monitor/recorder channel 1.
WAKEUP2	Input	Event input for event monitor/recorder channel 2.
SAMPLE	Output	Sample clock output for the event monitor/recorder. Use the CREG0 register to enable this pin for the sample output. (see Table 88).

37.7 Register description

Reset values apply only to a power-up of the Event Monitor/Recorder block, other types of reset have no effect on this block. Since the Event Monitor/Recorder is powered whenever either of the $V_{DD(REG)(3V3)}$, or V_{BAT} supplies are present, power-up reset occurs only when both supplies were absent and then one is turned on. The Reset Value reflects the data stored in used bits only. It does not include reserved bits content.

Table 837. Register overview: event monitor/recorder (base address 0x4004 6000)

Name	Access	Address offset	Description	Reset value	Reference
ERSTATUS	R/W	0x080	Event Monitor/Recorder Status register. Contains status flags for event channels and other Event Monitor/Recorder conditions.	0	Table 839
ERCONTROL	R/W	0x084	Event Monitor/Recorder Control register. Contains bits that control actions for the event channels as well as for Event Monitor/Recorder setup.	0	Table 838
ERCOUNTERS	RO	0x088	Event Monitor/Recorder Counters register. Allows reading the counters associated with the event channels.	0	Table 840
ERFIRSTSTAMP0	RO	0x090	Event Monitor/Recorder First Stamp register for channel 0. Retains the time stamp for the first event on channel 0.	NA	Table 841
ERFIRSTSTAMP1	RO	0x094	Event Monitor/Recorder First Stamp register for channel 1 (see ERFIRSTSTAMP0 description).	NA	Table 841
ERFIRSTSTAMP2	RO	0x098	Event Monitor/Recorder First Stamp register for channel 2 (see ERFIRSTSTAMP0 description).	NA	Table 841
ERLASTSTAMP0	RO	0x0A0	Event Monitor/Recorder Last Stamp register for channel 0. Retains the time stamp for the last (i.e. most recent) event on channel 0.	NA	Table 842
ERLASTSTAMP1	RO	0x0A4	Event Monitor/Recorder Last Stamp register for channel 1 (see ERLASTSTAMP0 description).	NA	Table 842
ERLASTSTAMP2	RO	0x0A8	Event Monitor/Recorder Last Stamp register for channel 2 (see ERLASTSTAMP0 description).	NA	Table 842

37.7.1 Event Monitor/Recorder Control Register

The Event Monitor/Recorder Control Register allows setup of the Event Monitor/Recorder and individual control over aspects of each channel's operation.

Table 838. Event Monitor/Recorder Control Register (ERCONTROL - address 0x4004 6084) bit description

Bit	Symbol	Value	Description	Reset value
0	INTWAKE_EN0		Interrupt and wakeup enable for channel 0.	0
		0	No interrupt or wakeup will be generated by event channel 0.	
		1	An event in channel 0 will trigger an (RTC) interrupt and a wake-up request.	
1	GPCLEAR_EN0		Enables automatically clearing the RTC general purpose registers when an event occurs on channel 0.	0
		0	Channel 0 has no influence on the general purpose registers.	
		1	An event in channel 0 will clear the general purpose registers asynchronously.	
2	POL0		Selects the polarity of an event on input pin WAKEUP0.	0
		0	A channel 0 event is defined as a negative edge on WAKEUP0.	
		1	A channel 0 event is defined as a positive edge on WAKEUP0.	
3	EV0_INPUT_EN		Event enable control for channel 0. Event Inputs should remain DISABLED when not being used for event detection, particularly if the associated pin is being used for some other function.	0
		0	Event 0 input is disabled and forced high internally.	
		1	Event 0 input is enabled.	
9:4	-		Reserved. Read value is undefined, only zero should be written.	NA
10	INTWAKE_EN1		Interrupt and wakeup enable for channel 1.	0
		0	No interrupt or wakeup will be generated by event channel 1.	
		1	An event in channel 1 will trigger an (RTC) interrupt and a wake-up request.	
11	GPCLEAR_EN1		Enables automatically clearing the RTC general purpose registers when an event occurs on channel 1.	0
		0	Channel 1 has no influence on the general purpose registers.	
		1	An event in channel 1 will clear the general purpose registers asynchronously.	
12	POL1		Selects the polarity of an event on input pin WAKEUP1.	0
		0	A channel 1 event is defined as a negative edge on WAKEUP1.	
		1	A channel 1 event is defined as a positive edge on WAKEUP1.	
13	EV1_INPUT_EN		Event enable control for channel 1. Event Inputs should remain DISABLED when not being used for event detection, particularly if the associated pin is being used for some other function.	0
		0	Event 1 input is disabled and forced high internally.	
		1	Event 1 input is enabled.	
19:14	-		Reserved. Read value is undefined, only zero should be written.	NA
20	INTWAKE_EN2		Interrupt and wakeup enable for channel 2.	
		0	No interrupt or wakeup will be generated by event channel 2.	
		1	An event in channel 2 will trigger an (RTC) interrupt and a wake-up request.	

Table 838. Event Monitor/Recorder Control Register (ERCONTROL - address 0x4004 6084) bit description

Bit	Symbol	Value	Description	Reset value
21	GPCLEAR_EN2		Enables automatically clearing the RTC general purpose registers when an event occurs on channel 2.	0
		0	Channel 2 has no influence on the general purpose registers.	
		1	An event in channel 2 will clear the general purpose registers asynchronously.	
22	POL2		Selects the polarity of an event on input pin WAKEUP2.	0
		0	A channel 2 event is defined as a negative edge on WAKEUP2.	
		1	A channel 2 event is defined as a positive edge on WAKEUP2.	
23	EV2_INPUT_EN		Event enable control for channel 2. Event Inputs should remain DISABLED when not being used for event detection, particularly if the associated pin is being used for some other function.	0
		0	Event 2 input is disabled and forced high internally.	
		1	Event 2 input is enabled.	
29:24	-		Reserved. Read value is undefined, only zero should be written.	NA
31:30	ERMODE		Controls enabling the Event Monitor/Recorder and selecting its operating frequency. Event Monitor/Recorder registers can always be written to regardless of the state of these bits. Events occurring during the 1-sec interval immediately following enabling of the clocks may not be recognized.	0
		0x0	Disable Event Monitor/Recorder clocks. Operation of the Event Monitor/Recorder is disabled except for asynchronous clearing of GP registers if selected.	
		0x1	16 Hz sample clock. Enable Event Monitor/Recorder and select a 16 Hz sample clock for event input edge detection and glitch suppression. Pulses (in either direction) shorter than 62.5 ms to 125 ms will be filtered out.	
		0x2	64 Hz sample clock. Enable Event Monitor/Recorder and select a 64 Hz sample clock for event input edge detection and glitch suppression. Pulses (in either direction) shorter than 15.6 ms to 31.2 ms will be filtered out.	
		0x3	1 kHz sample clock. Enable Event Monitor/Recorder and select a 1 kHz sample clock for event input edge detection and glitch suppression. Pulses (in either direction) shorter than 1 ms to 2 ms will be filtered out.	

37.7.2 Event Monitor/Recorder Status Register

The Event Monitor/Recorder Status Register contains flags for the 3 event channels, general purpose register clear flag, and the interrupt/wakeup flag.

Table 839. Event Monitor/Recorder Status Register (ERSTATUS - address 0x4004 6080) bit description

Bit	Symbol	Value	Description	Reset value
0	EV0		Channel0 event flag (WAKEUP0 pin). Set at the end of any second if there has been an event during the preceding second. This bit is cleared by writing a 1 to it. Writing 0 has no effect.	0
		0	No event change on channel 0.	
		1	At least one event has occurred on channel 0.	
1	EV1		Channel1 Event flag (WAKEUP1 pin). Set at the end of any second if there has been an event during the preceding second. This bit is cleared by writing a 1 to it. Writing 0 has no effect.	0
		0	No event change on channel 1.	
		1	At least one event has occurred on channel 1.	
2	EV2		Channel2 Event flag (WAKEUP2 pin). Set at the end of any second if there has been an event during the preceding second. This bit is cleared by writing a 1 to it. Writing 0 has no effect.	0
		0	No event change on channel 2.	
		1	At least one event has occurred on channel 2.	
3	GP_CLEARED		General purpose register asynchronous clear flag. This bit is cleared by writing a 1 to it. Writing 0 has no effect.	0
		0	General purpose registers have not been asynchronous cleared.	
		1	General purpose registers have been asynchronous cleared.	
30:4	-		Reserved. Read value is undefined, only zero should be written.	NA
31	WAKEUP		Interrupt/wakeup request flag (Read-only). This bit is cleared by writing a 1 to it. Writing 0 has no effect.	0
		0	No interrupt/wakeup request is pending	
		1	An interrupt/wakeup request is pending.	

37.7.3 Event Monitor/Recorder Counters Register

The Event Monitor/Recorder Counters Register is a read-only register that allows reading counters that record the number of events on each Event Monitor/Recorder channel.

Table 840. Event Monitor/Recorder Counters Register (ERCOUNTERS - address 0x4004 6088) bit description

Bit	Symbol	Description	Reset value
2:0	COUNTER0	Value of the counter for Event 0. If the counter reaches full count (the value 7), it remains there if additional events occur. This counter is cleared when the corresponding EVx bit in the ERSTATUS register is cleared by software.	0
7:3	-	Reserved. The value read from a reserved bit is not defined.	NA
10:8	COUNTER1	Value of the counter for event 1. See description for COUNTER0.	0
15:11	-	Reserved. The value read from a reserved bit is not defined.	NA
18:16	COUNTER2	Value of the counter for event 2. See description for COUNTER0.	0
31:19	-	Reserved. The value read from a reserved bit is not defined.	NA

37.7.4 Event Monitor/Recorder First Stamp Registers

The read-only Event Monitor/Recorder First Stamp Registers record a timestamp (from the RTC) of the first event that occurs on each Event Monitor/Recorder channel. This is when the corresponding EVx bit in the ERSTATUS register becomes set. Once that has happened, these registers will not change until software clears the corresponding EVx bit in the ERSTATUS register.

Contents of these register are only valid if the corresponding EVx bit in the ERSTATUS register = 1.

Table 841. Event Monitor/Recorder First Stamp Register (ERFIRSTSTAMP0 - 0x0x4004 6090, ERFIRSTSTAMP1 - 0x0x4004 6094, ERFIRSTSTAMP2 - 0x4004 6098) bit description

Bit	Symbol	Description	Reset value
5:0	SEC	Seconds value in the range of 0 to 59.	NA
11:6	MIN	Minutes value in the range of 0 to 59.	NA
16:12	HOUR	Hours value in the range of 0 to 23.	NA
25:17	DOY	Day of Year value in the range of 1 to 366.	NA
31:26	-	Reserved. The value read from a reserved bit is not defined.	NA

37.7.5 Event Monitor/Recorder Last Stamp Registers

The read-only Event Monitor/Recorder Last Stamp Registers record a timestamp (from the RTC) whenever an event occurs on each Event Monitor/Recorder channel.

Contents of these register are only valid if the corresponding EVx bit in the ERSTATUS register = 1.

Note that after a first event on any channel, the contents of the corresponding ERFIRSTSTAMP and ERLASTSTAMP registers will be the same (the first event and the most recent event being the same). The values will diverge if a second event occurs on the same channel

Table 842. Event Monitor/Recorder Last Stamp Register (ERLASTSTAMP0 - 0x0x4004 60A0, ERLASTSTAMP1 - 0x0x4004 60A4, ERLASTSTAMP2 - 0x4004 60A8) bit description

Bit	Symbol	Description	Reset value
5:0	SEC	Seconds value in the range of 0 to 59.	NA
11:6	MIN	Minutes value in the range of 0 to 59.	NA
16:12	HOUR	Hours value in the range of 0 to 23.	NA
25:17	DOY	Day of Year value in the range of 1 to 366.	NA
31:26	-	Reserved. The value read from a reserved bit is not defined.	NA

38.1 How to read this chapter

The USART0/2/3 controllers are available on all LPC18xx parts.

38.2 Basic configuration

The USART0/2/3 are configured as follows:

- See [Table 843](#) for clocking and power control.
- The USART0/2/3 are reset by the USART0/2/3_RST (reset #44/46/47).
- The USART0/2/3 interrupts are connected to slots # 24/26/27 in the NVIC.
- For connecting the USART0/2/3 receive and transmit lines to the GPDMA, use the DMAMUX register in the CREG block (see [Table 92](#)).
- The internal USART transmit/receive active signals (USARTx TX/RX) are connected to the GIMA (see [Table 190](#)). These signals are driven when data are transmitted or received and can be used to trigger any of the timers or the SCT.
- In synchronous mode, set the clock frequency on pin U0/2/3_UCLK to $\leq 6 \times \text{BASE_USART0/2/3_CLK}$.

Table 843. USART0/2/3 clocking and power control

	Base clock	Branch clock	Operating frequency
USART0 clock to register interface	BASE_M3_CLK	CLK_M3_UART0	up to 180 MHz
USART0 peripheral clock (PCLK)	BASE_UART0_CLK	CLK_APB0_UART0	up to 180 MHz
USART2 clock to register interface	BASE_M3_CLK	CLK_M3_UART2	up to 180 MHz
USART2 peripheral clock (PCLK)	BASE_UART2_CLK	CLK_APB2_UART2	up to 180 MHz
USART3 clock to register interface	BASE_M3_CLK	CLK_M3_UART3	up to 180 MHz
USART3 peripheral clock (PCLK)	BASE_UART3_CLK	CLK_APB2_UART3	up to 180 MHz

38.3 Features

- 16-byte receive and transmit FIFOs.
- Register locations conform to '550 industry standard.
- Receiver FIFO trigger points at 1, 4, 8, and 14 bytes.
- Built-in baud rate generator.
- UART mode allows for implementation of either software or hardware flow control.
- RS-485/EIA-485 9-bit mode support with output enable.
- Support for synchronous mode UART (USART).
- IrDA interface (USART3 only).
- DMA support.
- Smart Card interface.

38.4 General description

The architecture of the USART is shown below in the block diagram.

The APB interface provides a communications link between the CPU or host and the USART.

The USART receiver block, RX, monitors the serial input line, RXD, for valid input. The USART RX Shift Register (RSR) accepts valid characters via RXD. After a valid character is assembled in the RSR, it is passed to the USART RX Buffer Register FIFO to await access by the CPU or host via the generic host interface.

The USART transmitter block, TX, accepts data written by the CPU or host and buffers the data in the USART TX Holding Register FIFO (THR). The USART TX Shift Register (TSR) reads the data stored in the THR and assembles the data to transmit via the serial output pin, TXD1.

The USART Baud Rate Generator block, BRG, generates the timing enables used by the USART TX and RX blocks. The BRG clock input source is PCLK. The main clock is divided down per the divisor specified in the DLL and DLM registers. This divided down clock is a 16x oversample clock, NBAUDOUT.

The interrupt interface contains registers IER and IIR. The interrupt interface receives several one clock wide enables from the TX and RX blocks.

Status information from the TX and RX is stored in the LSR. Control information for the TX and RX is stored in the LCR.

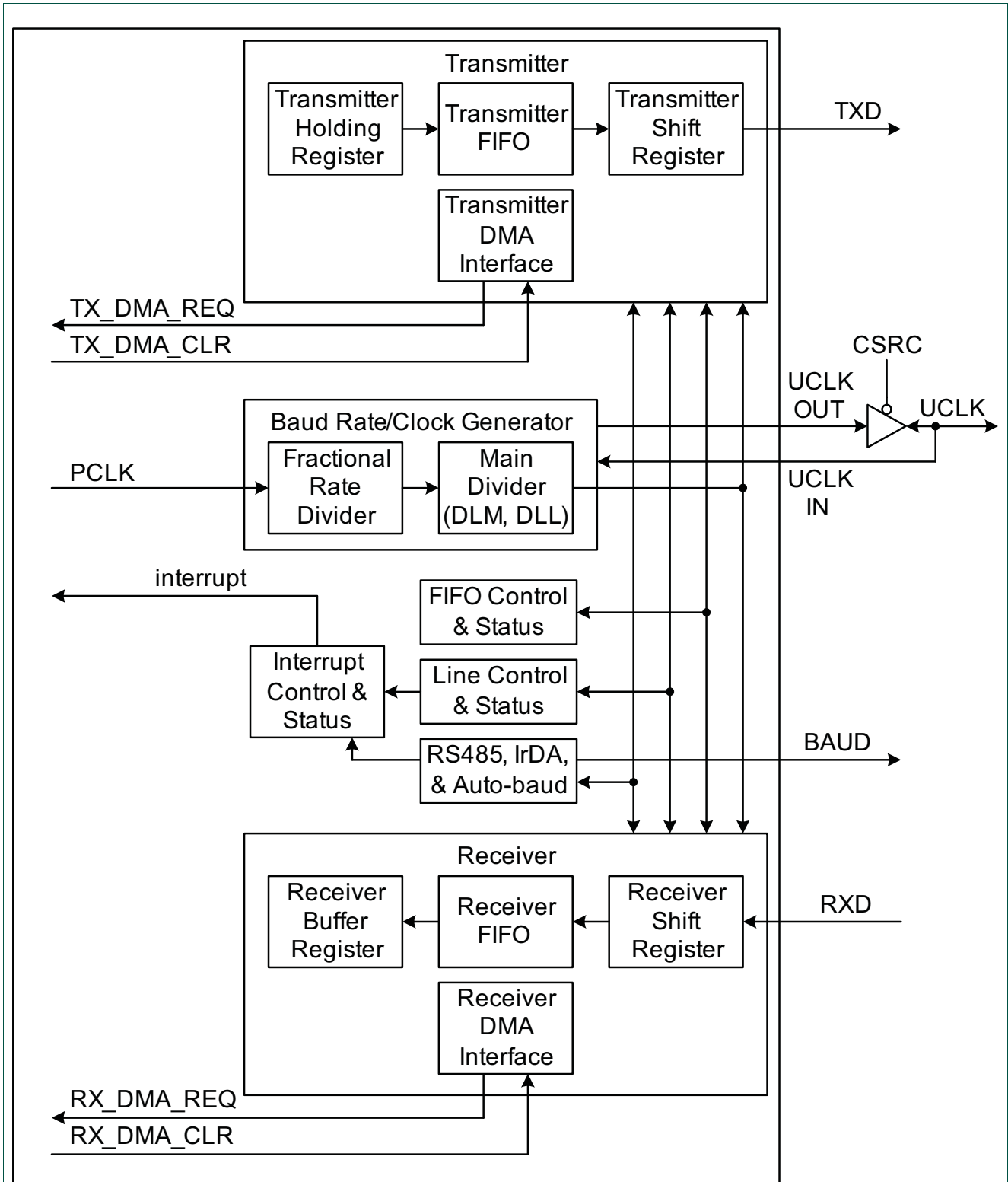

Fig 115. USART block diagram

38.5 Pin description

Table 844. USART0/2/3 pin description

Pin function	Direction	Description
USART0		
U0_RXD	I	Serial Input. Serial receive data.
U0_TXD	O	Serial Output. Serial transmit data.
U0_DIR	I/O	RS-485/EIA-485 output enable/direction control.
U0_UCLK	I/O	Serial clock input/output for USART0 in synchronous mode.
USART2		
U2_RXD	I	Serial Input. Serial receive data.
U2_TXD	O	Serial Output. Serial transmit data.
U2_DIR	I/O	RS-485/EIA-485 output enable/direction control.
U2_UCLK	I/O	Serial clock input/output for USART2 in synchronous mode.
USART3		
U3_RXD	I	Serial Input. Serial receive data.
U3_TXD	O	Serial Output. Serial transmit data.
U3_DIR	I/O	RS-485/EIA-485 output enable/direction control.
U3_UCLK	I/O	Serial clock input/output for USART3 in synchronous mode.
U3_BAUD	O	USART3 baud output. U3_BAUD is an active LOW signal of the single clock cycle and is generated at each rising edge of a 16x clock signal for the transmitter section of the UART. The clock rate is established by the USART3 clock frequency divided by the fractional divider and the divisor specified in the baud generator divisor latches. U3_BAUD can be used as an input to an external IrDA module.

38.6 Register description

The USART contains registers organized as shown in [Table 845](#). The Divisor Latch Access Bit (DLAB) is contained in LCR[7] and enables access to the Divisor Latches.

Reset value reflects the data stored in used bits only. It does not include the content of reserved bits.

Table 845. Register overview: USART0/2/3 (base address: 0x4008 1000, 0x400C 1000, 0x400C 2000)

Name	Access	Address offset	Description	Reset value	Reset value after UART0/3 boot	Reference
RBR	RO	0x000	Receiver Buffer Register. Contains the next received character to be read (DLAB = 0).	-	-	Table 846
THR	WO	0x000	Transmit Holding Register. The next character to be transmitted is written here (DLAB = 0).	-	-	Table 847
DLL	R/W	0x000	Divisor Latch LSB. Least significant byte of the baud rate divisor value. The full divisor is used to generate a baud rate from the fractional rate divider (DLAB = 1).	0x1	0x1	Table 848
DLM	R/W	0x004	Divisor Latch MSB. Most significant byte of the baud rate divisor value. The full divisor is used to generate a baud rate from the fractional rate divider (DLAB = 1).	0	0	Table 849
IER	R/W	0x004	Interrupt Enable Register. Contains individual interrupt enable bits for the 7 potential USART interrupts (DLAB = 0).	0	0	Table 850
IIR	RO	0x008	Interrupt ID Register. Identifies which interrupt(s) are pending.	0x1	0xC1	Table 851
FCR	WO	0x008	FIFO Control Register. Controls USART FIFO usage and modes.	0	0	Table 853
LCR	R/W	0x00C	Line Control Register. Contains controls for frame formatting and break generation.	0	0x3	Table 854
-	-	0x010	Reserved	-	-	-
LSR	RO	0x014	Line Status Register. Contains flags for transmit and receive status, including line errors.	0x60	0x61	Table 855
-	-	0x018	Reserved	-	-	-
SCR	R/W	0x01C	Scratch Pad Register. Eight-bit temporary storage for software.	0	0	Table 856
ACR	R/W	0x020	Auto-baud Control Register. Contains controls for the auto-baud feature.	0	0x6	Table 857
ICR	R/W	0x024	IrDA control register (USART3 only)	0	0	Table 858
FDR	R/W	0x028	Fractional Divider Register. Generates a clock input for the baud rate divider.	0x10	0x85	Table 860
OSR	R/W	0x02C	Oversampling Register. Controls the degree of oversampling during each bit time.	0xF0	0xF0	Table 861
-	-	0x030 - 0x03C	Reserved	-	-	-
HDEN	R/W	0x040	Half-duplex enable Register	-	-	Table 862
-	-	0x044	Reserved	-	-	-
SCICTRL	R/W	0x048	Smart card interface control register	0	0	Table 863
RS485CTRL	R/W	0x04C	RS-485/EIA-485 Control. Contains controls to configure various aspects of RS-485/EIA-485 modes.	0	0	Table 864
RS485ADRMATCH	R/W	0x050	RS-485/EIA-485 address match. Contains the address match value for RS-485/EIA-485 mode.	0	0	Table 865

Table 845. Register overview: USART0/2/3 (base address: 0x4008 1000, 0x400C 1000, 0x400C 2000)

Name	Access	Address offset	Description	Reset value	Reset value after UART0/3 boot	Reference
RS485DLY	R/W	0x054	RS-485/EIA-485 direction control delay.	0	0	Table 866
SYNCCTRL	R/W	0x058	Synchronous mode control register.	0	0	Table 867
TER	R/W	0x05C	Transmit Enable Register. Turns off USART transmitter for use with software flow control.	0x1	0x1	Table 868

38.6.1 USART Receiver Buffer Register

The RBR is the top byte of the USART RX FIFO. The top byte of the RX FIFO contains the oldest character received and can be read via the bus interface. The LSB (bit 0) represents the “oldest” received data bit. If the character received is less than 8 bits, the unused MSBs are padded with zeroes.

The Divisor Latch Access Bit (DLAB) in LCR must be zero in order to access the RBR. The RBR is always Read Only.

Since PE, FE and BI bits (see [Table 855](#)) correspond to the byte sitting on the top of the RBR FIFO (i.e. the one that will be read in the next read from the RBR), the right approach for fetching the valid pair of received byte and its status bits is first to read the content of the LSR register, and then to read a byte from the RBR.

Table 846. USART Receiver Buffer Registers when DLAB = 0, Read Only (RBR - addresses 0x4008 1000 (USART0), 0x400C 1000 (USART2), 0x400C 2000 (USART3)) bit description

Bit	Symbol	Description	Reset value
7:0	RBR	Receiver buffer. The USART Receiver Buffer Register contains the oldest received byte in the USART RX FIFO.	undefined
31:8	-	Reserved	-

38.6.2 USART Transmitter Holding Register

The THR is the top byte of the USART TX FIFO. The top byte is the newest character in the TX FIFO and can be written via the bus interface. The LSB represents the first bit to transmit.

The Divisor Latch Access Bit (DLAB) in LCR must be zero in order to access the THR. The THR is always Write Only.

Table 847. USART Transmitter Holding Register when DLAB = 0, Write Only (THR - addresses 0x4008 1000 (USART0), 0x400C 1000 (USART2), 0x400C 2000 (USART3)) bit description

Bit	Symbol	Description	Reset value
7:0	THR	Transmit Holding Register. Writing to the USART Transmit Holding Register causes the data to be stored in the USART transmit FIFO. The byte will be sent when it reaches the bottom of the FIFO and the transmitter is available.	NA
31:8	-	Reserved	-

38.6.3 USART Divisor Latch LSB and MSB Registers

The USART Divisor Latch is part of the USART Baud Rate Generator and holds the value used, along with the Fractional Divider, to divide the USART_PCLK clock in order to produce the baud rate clock, which must be 16x the desired baud rate. The DLL and DLM registers together form a 16-bit divisor where DLL contains the lower 8 bits of the divisor and DLM contains the higher 8 bits of the divisor. A 0x0000 value is treated like a 0x0001 value as division by zero is not allowed. The Divisor Latch Access Bit (DLAB) in LCR must be one in order to access the USART Divisor Latches. Details on how to select the right value for DLL and DLM can be found in [Section 38.6.12](#).

Table 848. USART Divisor Latch LSB Register when DLAB = 1 (DLL - addresses 0x4008 1000 (USART0), 0x400C 1000 (USART2), 0x400C 2000 (USART3)) bit description

Bit	Symbol	Description	Reset value
7:0	DLLSB	Divisor latch LSB. The USART Divisor Latch LSB Register, along with the DLM register, determines the baud rate of the USART.	0x01
31:8	-	Reserved	-

Table 849. USART Divisor Latch MSB Register when DLAB = 1 (DLM - addresses 0x4008 1004 (USART0), 0x400C 1004 (USART2), 0x400C 2004 (USART3)) bit description

Bit	Symbol	Description	Reset value
7:0	DLMSB	Divisor latch MSB. The USART Divisor Latch MSB Register, along with the DLL register, determines the baud rate of the USART.	0x00
31:8	-	Reserved	-

38.6.4 USART Interrupt Enable Register

The IER is used to enable the four USART interrupt sources.

Table 850. USART Interrupt Enable Register when DLAB = 0 (IER - addresses 0x4008 1004 (USART0), 0x400C 1004 (USART2), 0x400C 2004 (USART3)) bit description

Bit	Symbol	Value	Description	Reset value
0	RBRIE		RBR Interrupt Enable. Enables the Receive Data Available interrupt for USART. It also controls the Character Receive Time-out interrupt.	0
		0	Disable the RDA interrupt.	
		1	Enable the RDA interrupt.	
1	THREIE		THRE Interrupt Enable. Enables the THRE interrupt for USART. The status of this interrupt can be read from LSR[5].	0
		0	Disable the THRE interrupt.	
		1	Enable the THRE interrupt.	
2	RXIE		RX Line Interrupt Enable. Enables the USART RX line status interrupts. The status of this interrupt can be read from LSR[4:1].	0
		0	Disable the RX line status interrupts.	
		1	Enable the RX line status interrupts.	
3	-	-	Reserved	-
6:4	-	-	Reserved, user software should not write ones to reserved bits. The value read from a reserved bit is not defined.	NA
7	-	-	Reserved	0
8	ABEOINTEN		Enables the end of auto-baud interrupt.	0
		0	Disable end of auto-baud Interrupt.	
		1	Enable end of auto-baud Interrupt.	

Table 850. USART Interrupt Enable Register when DLAB = 0 (IER - addresses 0x4008 1004 (USART0), 0x400C 1004 (USART2), 0x400C 2004 (USART3)) bit description

Bit	Symbol	Value	Description	Reset value
9	ABTOINTEN		Enables the auto-baud time-out interrupt.	0
		0	Disable auto-baud time-out Interrupt.	
		1	Enable auto-baud time-out Interrupt.	
31:10	-		Reserved, user software should not write ones to reserved bits. The value read from a reserved bit is not defined.	NA

38.6.5 USART Interrupt Identification Register

IIR provides a status code that denotes the priority and source of a pending interrupt. The interrupts are frozen during a IIR access. If an interrupt occurs during a IIR access, the interrupt is recorded for the next IIR access.

Table 851. USART Interrupt Identification Register, read only (IIR - addresses 0x4008 1008 (USART0), 0x400C 1008 (USART2), 0x400C 2008 (USART3)) bit description

Bit	Symbol	Value	Description	Reset value
0	INTSTATUS		Interrupt status. Note that IIR[0] is active low. The pending interrupt can be determined by evaluating IIR[3:1].	1
		0	At least one interrupt is pending.	
		1	No interrupt is pending.	
3:1	INTID		Interrupt identification. IER[3:1] identifies an interrupt corresponding to the USART Rx FIFO. All other combinations of IER[3:1] not listed below are reserved (100,101,111).	0
		0x3	Priority 1 (highest) - Receive Line Status (RLS).	
		0x2	Priority 2 - Receive Data Available (RDA).	
		0x6	Priority 2 - Character Time-out Indicator (CTI).	
		0x1	Priority 3 - THRE Interrupt.	
		0x0	Priority 4 (lowest) - Reserved.	
5:4	-		Reserved, user software should not write ones to reserved bits. The value read from a reserved bit is not defined.	NA
7:6	FIFOENABLE		Copies of FCR[0].	0
8	ABEOINT		End of auto-baud interrupt. True if auto-baud has finished successfully and interrupt is enabled.	0
9	ABTOINT		Auto-baud time-out interrupt. True if auto-baud has timed out and interrupt is enabled.	0
31:10	-		Reserved, user software should not write ones to reserved bits. The value read from a reserved bit is not defined.	NA

Bits IIR[9:8] are set by the auto-baud function and signal a time-out or end of auto-baud condition. The auto-baud interrupt conditions are cleared by setting the corresponding Clear bits in the Auto-baud Control Register.

If the `IntStatus` bit is one and no interrupt is pending and the `IntId` bits will be zero. If the `IntStatus` is 0, a non auto-baud interrupt is pending in which case the `IntId` bits identify the type of interrupt and handling as described in [Table 852](#). Given the status of `IIR[3:0]`, an interrupt handler routine can determine the cause of the interrupt and how to clear the active interrupt. The `IIR` must be read in order to clear the interrupt prior to exiting the Interrupt Service Routine.

The USART RLS interrupt (`IIR[3:1] = 011`) is the highest priority interrupt and is set whenever any one of four error conditions occur on the USART RX input: overrun error (OE), parity error (PE), framing error (FE) and break interrupt (BI). The USART Rx error condition that set the interrupt can be observed via `LSR[4:1]`. The interrupt is cleared upon a LSR read.

The USART RDA interrupt (`IIR[3:1] = 010`) shares the second level priority with the CTI interrupt (`IIR[3:1] = 110`). The RDA is activated when the USART Rx FIFO reaches the trigger level defined in `FCR7:6` and is reset when the USART Rx FIFO depth falls below the trigger level. When the RDA interrupt goes active, the CPU can read a block of data defined by the trigger level.

The CTI interrupt (`IIR[3:1] = 110`) is a second level interrupt and is set when the USART Rx FIFO contains at least one character and no USART Rx FIFO activity has occurred in 3.5 to 4.5 character times. Any USART Rx FIFO activity (read or write of USART RSR) will clear the interrupt. This interrupt is intended to flush the USART RBR after a message has been received that is not a multiple of the trigger level size. For example, if a peripheral wished to send a 105 character message and the trigger level was 10 characters, the CPU would receive 10 RDA interrupts resulting in the transfer of 100 characters and 1 to 5 CTI interrupts (depending on the service routine) resulting in the transfer of the remaining 5 characters.

Table 852. USART Interrupt Handling

IIR[3:0] value ^[1]	Priority	Interrupt type	Interrupt source	Interrupt reset
0001	-	None	None	-
0110	Highest	RX Line Status / Error	OE ^[2] or PE ^[2] or FE ^[2] or BI ^[2]	LSR Read ^[2]

Table 852. USART Interrupt Handling

IIR[3:0] value ^[1]	Priority	Interrupt type	Interrupt source	Interrupt reset
0100	Second	RX Data Available	Rx data available or trigger level reached in FIFO (FCR0=1)	RBR Read ^[3] or USART FIFO drops below trigger level
1100	Second	Character Time-out indication	Minimum of one character in the RX FIFO and no character input or removed during a time period depending on how many characters are in FIFO and what the trigger level is set at (3.5 to 4.5 character times). The exact time will be: $[(\text{word length}) \times 7 - 2] \times 8 + [(\text{trigger level} - \text{number of characters}) \times 8 + 1]$ RCLKs	RBR Read ^[3]
0010	Third	THRE	THRE ^[2]	IIR Read ^[4] (if source of interrupt) or THR write

[1] Values 0000, 0011, 010, 0111, 1000, 1001, 1010, 1011, 1101, 1110, 1111 are reserved.

[2] For details see [Section 38.6.8 “USART Line Status Register”](#)

[3] For details see [Section 38.6.1 “USART Receiver Buffer Register”](#)

[4] For details see [Section 38.6.5 “USART Interrupt Identification Register”](#) and [Section 38.6.2 “USART Transmitter Holding Register”](#)

The USART THRE interrupt (IIR[3:1] = 001) is a third level interrupt and is activated when the USART THR FIFO is empty provided certain initialization conditions have been met. These initialization conditions are intended to give the USART THR FIFO a chance to fill up with data to eliminate many THRE interrupts from occurring at system start-up. The initialization conditions implement a one character delay minus the stop bit whenever THRE = 1 and there have not been at least two characters in the THR at one time since the last THRE = 1 event. This delay is provided to give the CPU time to write data to THR without a THRE interrupt to decode and service. A THRE interrupt is set immediately if the USART THR FIFO has held two or more characters at one time and currently, the THR is empty. The THRE interrupt is reset when a THR write occurs or a read of the IIR occurs and the THRE is the highest interrupt (IIR[3:1] = 001).

38.6.6 USART FIFO Control Register

The FCR controls the operation of the USART RX and TX FIFOs.

Table 853. USART FIFO Control Register Write Only (FCR - addresses 0x4008 1008 (USART0), 0x400C 1008 (USART2), 0x400C 2008 (USART3)) bit description

Bit	Symbol	Value	Description	Reset value
0	FIFOEN		FIFO Enable.	0
		0	USART FIFOs are disabled. Must not be used in the application.	
		1	Active high enable for both USART Rx and TX FIFOs and FCR[7:1] access. This bit must be set for proper USART operation. Any transition on this bit will automatically clear the USART FIFOs.	
1	RXFIFO RES		RX FIFO Reset.	0
		0	No impact on either of USART FIFOs.	
		1	Writing a logic 1 to FCR[1] will clear all bytes in USART Rx FIFO, reset the pointer logic. This bit is self-clearing.	
2	TXFIFO RES		TX FIFO Reset.	0
		0	No impact on either of USART FIFOs.	
		1	Writing a logic 1 to FCR[2] will clear all bytes in USART TX FIFO, reset the pointer logic. This bit is self-clearing.	
3	DMAMODE		DMA Mode Select. When the FIFO enable bit (bit 0 of this register) is set, this bit selects the DMA mode.	0
5:4	-		Reserved, user software should not write ones to reserved bits. The value read from a reserved bit is not defined.	NA
7:6	RXTRIG LVL		RX Trigger Level. These two bits determine how many receiver USART FIFO characters must be written before an interrupt is activated.	0
		0x0	Trigger level 0 (1 character or 0x01).	
		0x1	Trigger level 1 (4 characters or 0x04).	
		0x2	Trigger level 2 (8 characters or 0x08).	
		0x3	Trigger level 3 (14 characters or 0x0E).	
31:8	-	-	Reserved	-

38.6.6.1 DMA Operation

The user can optionally operate the USART transmit and/or receive using DMA. The DMA mode is determined by the DMA Mode Select bit in the FCR register. Note that for DMA operation as for any operation of the USART, the FIFOs must be enabled via the FIFO Enable bit in the FCR register.

USART receiver DMA

In DMA mode, the receiver DMA request is asserted when the receiver FIFO level becomes equal to or greater than trigger level, or if a character time-out occurs. See the description of the RX Trigger Level above. The receiver DMA request is cleared by the DMA controller.

USART transmitter DMA

In DMA mode, the transmitter DMA request is asserted when the transmitter FIFO transitions to not full. The transmitter DMA request is cleared by the DMA controller.

38.6.7 USART Line Control Register

The LCR determines the format of the data character that is to be transmitted or received.

Table 854. USART Line Control Register (LCR - addresses 0x4008 100C (USART0), 0x400C 100C (USART2), 0x400C 200C (USART3)) bit description

Bit	Symbol	Value	Description	Reset Value
1:0	WLS		Word Length Select.	0
		0x0	5-bit character length.	
		0x1	6-bit character length.	
		0x2	7-bit character length.	
		0x3	8-bit character length.	
2	SBS		Stop Bit Select.	0
		0	1 stop bit.	
		1	2 stop bits (1.5 if LCR[1:0]=00).	
3	PE		Parity Enable	0
		0	Disable parity generation and checking.	
		1	Enable parity generation and checking.	
5:4	PS		Parity Select.	0
		0x0	Odd parity. Number of 1s in the transmitted character and the attached parity bit will be odd.	
		0x1	Even Parity. Number of 1s in the transmitted character and the attached parity bit will be even.	
		0x2	Forced "1" stick parity.	
		0x3	Forced "0" stick parity.	
6	BC		Break Control.	0
		0	Disable break transmission.	
		1	Enable break transmission. Output pin USART TXD is forced to logic 0 when LCR[6] is active high.	
7	DLAB		Divisor Latch Access Bit.	0
		0	Disable access to Divisor Latches.	
		1	Enable access to Divisor Latches.	
31: 8	-	-	Reserved	-

38.6.8 USART Line Status Register

The LSR is a Read Only register that provides status information on the USART TX and RX blocks.

Table 855. USART Line Status Register Read Only (LSR - addresses 0x4008 1014 (USART0), 0x400C 1014 (USART2), 0x400C 2014 (USART3)) bit description

Bit	Symbol	Value	Description	Reset Value
0	RDR		Receiver Data Ready. LSR[0] is set when the RBR holds an unread character and is cleared when the USART RBR FIFO is empty.	0
		0	RBR is empty.	
		1	RBR contains valid data.	
1	OE		Overrun Error. The overrun error condition is set as soon as it occurs. A LSR read clears LSR[1]. LSR[1] is set when USART RSR has a new character assembled and the USART RBR FIFO is full. In this case, the USART RBR FIFO will not be overwritten and the character in the USART RSR will be lost.	0
		0	Overrun error status is inactive.	
		1	Overrun error status is active.	
2	PE		Parity Error. When the parity bit of a received character is in the wrong state, a parity error occurs. A LSR read clears LSR[2]. Time of parity error detection is dependent on FCR[0]. Note: A parity error is associated with the character at the top of the USART RBR FIFO.	0
		0	Parity error status is inactive.	
		1	Parity error status is active.	
3	FE		Framing Error. When the stop bit of a received character is a logic 0, a framing error occurs. A LSR read clears LSR[3]. The time of the framing error detection is dependent on FCR0. Upon detection of a framing error, the RX will attempt to re-synchronize to the data and assume that the bad stop bit is actually an early start bit. However, it cannot be assumed that the next received byte will be correct even if there is no Framing Error. Note: A framing error is associated with the character at the top of the USART RBR FIFO.	0
		0	Framing error status is inactive.	
		1	Framing error status is active.	
4	BI		Break Interrupt. When RXD1 is held in the spacing state (all zeros) for one full character transmission (start, data, parity, stop), a break interrupt occurs. Once the break condition has been detected, the receiver goes idle until RXD1 goes to marking state (all ones). A LSR read clears this status bit. The time of break detection is dependent on FCR[0]. Note: The break interrupt is associated with the character at the top of the USART RBR FIFO.	0
		0	Break interrupt status is inactive.	
		1	Break interrupt status is active.	

Table 855. USART Line Status Register Read Only (LSR - addresses 0x4008 1014 (USART0), 0x400C 1014 (USART2), 0x400C 2014 (USART3)) bit description ...continued

Bit	Symbol	Value	Description	Reset Value
5	THRE		Transmitter Holding Register Empty. THRE is set immediately upon detection of an empty USART THR and is cleared on a THR write.	1
		0	THR contains valid data.	
		1	THR is empty.	
6	TEMT		Transmitter Empty. TEMT is set when both THR and TSR are empty; TEMT is cleared when either the TSR or the THR contain valid data.	1
		0	THR and/or the TSR contains valid data.	
		1	THR and the TSR are empty.	
7	RXFE		Error in RX FIFO. LSR[7] is set when a character with a RX error such as framing error, parity error or break interrupt, is loaded into the RBR. This bit is cleared when the LSR register is read and there are no subsequent errors in the USART FIFO.	0
		0	RBR contains no USART RX errors or FCR[0]=0.	
		1	USART RBR contains at least one USART RX error.	
8	TXERR		Error in transmitted character. A NACK response is given by the receiver in Smart card T=0 mode. This bit is cleared when the LSR register is read.	0
		0	No error (normal default condition).	
		1	A NACK response is received during Smart card T=0 operation.	
31:9	-	-	Reserved	-

38.6.9 USART Scratch Pad Register

The SCR has no effect on the USART operation. This register can be written and/or read at user's discretion. There is no provision in the interrupt interface that would indicate to the host that a read or write of the SCR has occurred.

Table 856. USART Scratch Pad Register (SCR - addresses 0x4008 101C (USART0), 0x400C 101C (USART2), 0x400C 201C (USART3)) bit description

Bit	Symbol	Description	Reset Value
7:0	PAD	Scratch pad. A readable, writable byte.	0x00
31:8	-	Reserved	-

38.6.10 USART Auto-baud Control Register

The USART Auto-baud Control Register (ACR) controls the process of measuring the incoming clock/data rate for the baud rate generation and can be read and written at user's discretion.

Table 857. Autobaud Control Register (ACR - addresses 0x4008 1020 (USART0), 0x400C 1020 (USART2), 0x400C 2020 (USART3)) bit description

Bit	Symbol	Value	Description	Reset value
0	START		Start bit. This bit is automatically cleared after auto-baud completion.	0
		0	Auto-baud stop (auto-baud is not running).	
		1	Auto-baud start (auto-baud is running). Auto-baud run bit. This bit is automatically cleared after auto-baud completion.	
1	MODE		Auto-baud mode select bit.	0
		0	Mode 0.	
		1	Mode 1.	
2	AUTORESTART		Restart bit.	0
		0	No restart	
		1	Restart in case of time-out (counter restarts at next USART Rx falling edge)	
7:3	-		Reserved, user software should not write ones to reserved bits. The value read from a reserved bit is not defined.	0
8	ABEOINTCLR		End of auto-baud interrupt clear bit (write-only).	0
		0	Writing a 0 has no impact.	
		1	Writing a 1 will clear the corresponding interrupt in the IIR.	
9	ABTOINTCLR		Auto-baud time-out interrupt clear bit (write-only).	0
		0	Writing a 0 has no impact.	
		1	Writing a 1 will clear the corresponding interrupt in the IIR.	
31:10	-		Reserved, user software should not write ones to reserved bits. The value read from a reserved bit is not defined.	0

38.6.11 IrDA Control Register (USART3)

The IrDA Control Register enables and configures the IrDA mode for USART3 only. The value of U3ICR should not be changed while transmitting or receiving data, or data loss or corruption may occur.

Remark: IrDA is available on USART3 only.

Table 858. IrDA Control Register (ICR - address 0x4000 8024) bit description

Bit	Symbol	Value	Description	Reset value
0	IRDAEN		IrDA mode enable.	0
		0	IrDA mode on USART3 is disabled, USART3 acts as a standard USART.	
		1	IrDA mode on USART3 is enabled.	

Table 858. IrDA Control Register (ICR - address 0x4000 8024) bit description

Bit	Symbol	Value	Description	Reset value
1	IRDAINV		Serial input direction.	0
		0	Not inverted.	
		1	Inverted. This has no effect on the serial output.	
2	FIXPULSEEN		IrDA fixed pulse width mode.	0
		0	Disabled.	
		1	Enabled.	
5:3	PULSEDIV		Configures the pulse when FixPulseEn = 1. See Table 859 for details.	0
		0x0	2xTPCLK	
		0x1	4xTPCLK	
		0x2	8xTPCLK	
		0x3	16xTPCLK	
		0x4	32xTPCLK	
		0x5	64xTPCLK	
		0x6	128xTPCLK	
		0x7	256xTPCLK	
31:6	-		Reserved, user software should not write ones to reserved bits. The value read from a reserved bit is not defined.	0

The PulseDiv bits in U3ICR are used to select the pulse width when the fixed pulse width mode is used in IrDA mode (IrDAEn = 1 and FixPulseEn = 1). The value of these bits should be set so that the resulting pulse width is at least 1.63 μs. [Table 859](#) shows the possible pulse widths.

Table 859. IrDA Pulse Width

FixPulseEn	PulseDiv	IrDA Transmitter Pulse width (μs)
0	x	3 / (16 × baud rate)
1	0	2 × T _{PCLK}
1	1	4 × T _{PCLK}
1	2	8 × T _{PCLK}
1	3	16 × T _{PCLK}
1	4	32 × T _{PCLK}
1	5	64 × T _{PCLK}
1	6	128 × T _{PCLK}
1	7	256 × T _{PCLK}

38.6.12 USART Fractional Divider Register

The USART Fractional Divider Register (FDR) controls the clock pre-scaler for the baud rate generation and can be read and written at the user’s discretion. This pre-scaler takes the APB clock and generates an output clock according to the specified fractional requirements.

Important: If the fractional divider is active (DIVADDVAL > 0) and DLM = 0, the value of the DLL register must be 3 or greater.

Table 860. USART Fractional Divider Register (FDR - addresses 0x4008 1028 (USART0), 0x400C 1028 (USART2), 0x400C 2028 (USART3)) bit description

Bit	Function	Description	Reset value
3:0	DIVADDVAL	Baud rate generation pre-scaler divisor value. If this field is 0, fractional baud rate generator will not impact the USART baud rate.	0
7:4	MULVAL	Baud rate pre-scaler multiplier value. This field must be greater or equal 1 for USART to operate properly, regardless of whether the fractional baud rate generator is used or not.	1
31:8	-	Reserved, user software should not write ones to reserved bits. The value read from a reserved bit is not defined.	0

This register controls the clock pre-scaler for the baud rate generation. The reset value of the register keeps the fractional capabilities of USART disabled making sure that USART is fully software and hardware compatible with USARTs not equipped with this feature.

The USART baud rate can be calculated as:

(6)

$$UART_{baudrate} = \frac{PCLK}{16 \times (256 \times DLM + DLL) \times \left(1 + \frac{DivAddVal}{MulVal}\right)}$$

Where USART_PCLK is the peripheral clock, DLM and DLL are the standard USART baud rate divider registers, and DIVADDVAL and MULVAL are USART fractional baud rate generator specific parameters.

The value of MULVAL and DIVADDVAL should comply to the following conditions:

1. $1 \leq MULVAL \leq 15$
2. $0 \leq DIVADDVAL \leq 14$
3. $DIVADDVAL < MULVAL$

The value of the FDR should not be modified while transmitting/receiving data or data may be lost or corrupted.

If the FDR register value does not comply to these two requests, then the fractional divider output is undefined. If DIVADDVAL is zero then the fractional divider is disabled, and the clock will not be divided.

38.6.13 USART Oversampling Register

In most applications, the USART samples received data 16 times in each nominal bit time and sends bits that are 16 input clocks wide. This register allows software to control the ratio between the input clock and bit clock. Oversampling is required for smart card mode and provides an alternative to fractional division for other modes.

Table 861. USART Oversampling Register (OSR - addresses 0x4008 102C (USART0), 0x400C 102C (USART2), 0x400C 20402C (USART3)) bit description

Bit	Symbol	Description	Reset value
0	-	Reserved, user software should not write ones to reserved bits. The value read from a reserved bit is not defined.	NA
3:1	OSFRAC	Fractional part of the oversampling ratio, in units of 1/8th of an input clock period. (001 = 0.125, ..., 111 = 0.875)	0
7:4	OSINT	Integer part of the oversampling ratio, minus 1. The reset values equate to the normal operating mode of 16 input clocks per bit time.	0xF
14:8	FDINT	In Smart Card mode, these bits act as a more-significant extension of the OSint field, allowing an oversampling ratio up to 2048 as required by ISO7816-3. In Smart Card mode, bits 14:4 should initially be set to 371, yielding an oversampling ratio of 372.	0
31:15	-	Reserved, user software should not write ones to reserved bits. The value read from a reserved bit is not defined.	NA

Example: For a baud rate of 3.25 Mbps with a 24 MHz USART clock frequency, the ideal oversampling ratio is $24/3.25$ or 7.3846. Setting OSINT to 0110 (binary) for 7 clocks/bit and OSFrac to 011 (binary) for 0.375 clocks/bit, results in an oversampling ratio of 7.375.

In Smart card mode, OSInt is extended by FDINT. This extends the possible oversampling to 2048, as required to support ISO 7816-3. Note that this value can be exceeded when $D < 0$, but this is not supported by the USART. When Smart card mode is enabled, the initial value of OSINT and FDINT should be programmed as 00101110011 (binary) (372 minus one).

38.6.14 USART Half-duplex enable register

Remark: The HDEN register should be disabled when in smart card mode (smart card by default runs in half-duplex mode).

After reset the USART will be in full-duplex mode, meaning that both TX and RX work independently. After setting the HDEN bit, the USART will be in half-duplex mode. In this mode, the USART ensures that the receiver is locked when idle, or will enter a locked state after having received a complete ongoing character reception. Line conflicts must be handled in software. The behavior of the USART is unpredictable when data is presented for reception while data is being transmitted.

For this reason, the value of the HDEN register should not be modified while sending or receiving data, or data may be lost or corrupted.

Table 862. USART Half duplex enable register (HDEN - addresses 0x4008 1040 (USART0), 0x400C 1040 (USART2), 0x400C 2040 (USART3)) bit description

Bit	Symbol	Value	Description	Reset value
0	HDEN		Half-duplex mode enable	0
		0	Disable half-duplex mode.	
		1	Enable half-duplex mode.	
31:1	-		Reserved, user software should not write ones to reserved bits. The value read from a reserved bit is not defined.	-

38.6.15 USART Smart card interface control register

Table 863. USART Smart card interface control register (SCICTRL - addresses 0x4008 1048 (USART0), 0x400C 1048 (USART2), 0x400C 2048 (USART3)) bit description

Bit	Symbol	Value	Description	Reset value
0	SCIEN		Smart Card Interface Enable.	0
		0	Smart card interface disabled.	
		1	Asynchronous half duplex smart card interface is enabled.	
1	NACKDIS		NACK response disable. Only applicable in T=0.	0
		0	A NACK response is enabled.	
		1	A NACK response is inhibited.	
2	PROTSEL		Protocol selection as defined in the ISO7816-3 standard.	0
		0	T = 0	
		1	T = 1	
4:3	-		Reserved, user software should not write ones to reserved bits. The value read from a reserved bit is not defined.	0
7:5	TXRETRY		Maximum number of retransmissions in case of a negative acknowledge (protocol T=0). When the retry counter is exceeded, the USART will be locked until the FIFO is cleared. A TX error interrupt is generated when enabled.	-
15:8	GUARDTIME		Extra guard time. No extra guard time (0x0) results in a standard guard time as defined in ISO 7816-3, depending on the protocol type. A guard time of 0xFF indicates a minimal guard time as defined for the selected protocol.	-
31:16	-	-	Reserved, user software should not write ones to reserved bits. The value read from a reserved bit is not defined.	-

After reset the USART smart card interface will be disabled. After setting the SCIEN bit the USART will be in ISO 7816-3 compliant asynchronous smart card mode T=0.

The NACKDIS bit is used to inhibit a nack response during T=0 (the I/O line is not pulled low during the guard time to indicate an erroneous reception). The received character will be stored in the RX FIFO but a parity error will be generated. It is up to the software to handle the incorrect received character.

The PROTSEL bit is used to selected between the two supported smart card protocols T=0 and T=1. More information on these protocols can be found in the ISO 7816-3 standard.

The retry bit field indicates the number of retransmission when receiving a NACK response, which can be up to 7 trails. When the number is exceeded, an interrupt is generated and the USART is locked until the FIFO is empty. This can be done by flushing the FIFO. When no FIFO is available, or the FIFO is already empty, the interrupt can be used by the software to determine the next action.

The guard time bit file is used to program the extra number of guard time cycles to allow the smart card to process the information before sending a response. The extra guard time can be programmed from 0 to 255, where 255 indicates the minimum possible character length. This value is depending on the selected protocol and can be either 11 etu for protocol T=1 or 12 etu for protocol T=0.

Waiting times as defined in the standard cannot be programmed directly but are implemented using the capture inputs of the timers.

Remark: The SCICTRL register should not be modified while sending or receiving data, or data may be lost or corrupted.

Remark: The SCICTRL register should not be enabled in combination with the SYNCCTRL register, as only asynchronous smart card is supported.

38.6.16 USART RS485 Control register

The RS485CTRL register controls the configuration of the USART in RS-485/EIA-485 mode.

Table 864. USART RS485 Control register (RS485CTRL - addresses 0x4008 104C (USART0), 0x400C 104C (USART2), 0x400C 204C (USART3)) bit description

Bit	Symbol	Value	Description	Reset value
0	NMMEN		NMM enable.	0
		0	RS-485/EIA-485 Normal Multidrop Mode (NMM) is disabled.	
		1	RS-485/EIA-485 Normal Multidrop Mode (NMM) is enabled. In this mode, an address is detected when a received byte causes the USART to set the parity error and generate an interrupt.	
1	RXDIS		Receiver enable.	0
		0	The receiver is enabled.	
		1	The receiver is disabled.	
2	AADEN		AAD enable	0
		0	Auto Address Detect (AAD) is disabled.	
		1	Auto Address Detect (AAD) is enabled.	

Table 864. USART RS485 Control register (RS485CTRL - addresses 0x4008 104C (USART0), 0x400C 104C (USART2), 0x400C 204C (USART3)) bit description ...continued

Bit	Symbol	Value	Description	Reset value
3	-	-	Reserved.	-
4	DCTRL	-	Direction control for DIR pin.	0
		0	Disable Auto Direction Control.	
		1	Enable Auto Direction Control.	
5	OINV	-	Direction control pin polarity. This bit reverses the polarity of the direction control signal on the DIR pin.	0
		0	The direction control pin will be driven to logic '0' when the transmitter has data to be sent. It will be driven to logic '1' after the last bit of data has been transmitted.	
		1	The direction control pin will be driven to logic '1' when the transmitter has data to be sent. It will be driven to logic '0' after the last bit of data has been transmitted.	
31:6	-	-	Reserved, user software should not write ones to reserved bits. The value read from a reserved bit is not defined.	NA

After reset RS485 mode will be disabled. The RS485 feature allows the USART to be configured as one of multiple addressable slave receivers controlled by a single USART. In RS485 mode the USART differentiates between an address character and a data character by means of a ninth bit. The parity bit is used to implement this bit, and when set to '1' indicates an address and when set to '0' indicates data. RS485 mode is enabled by setting the NMMEN bit. The USART slave receiver can be assigned a unique address and, manually or automatically, reject or accept data based on a received address. See section [Section 38.7.4](#) for details.

38.6.17 USART RS485 Address Match register

The RS485ADRMATCH register contains the address match value for RS-485/EIA-485 mode.

Table 865. USART RS485 Address Match register (RS485ADRMATCH - addresses 0x4008 1050 (USART0), 0x400C 1050 (USART2), 0x400C 2050 (USART3)) bit description

Bit	Symbol	Description	Reset value
7:0	ADRMATCH	Contains the address match value.	0x00
31:8	-	Reserved	-

The ADRMATCH bit field contains the slave address match value that is used to compare a received address value to. During automatic address detection, this value is used to accept or reject serial input data.

38.6.18 USART RS485 Delay value register

The user may program the 8-bit RS485DLY register with a delay between the last stop bit leaving the TXFIFO and the de-assertion of the DIR pin. This delay time is in periods of the baud clock. Any delay time from 0 to 255 bit times may be programmed.

Table 866. USART RS485 Delay value register (RS485DLY - addresses 0x4008 1054 (USART0), 0x400C 1054 (USART2), 0x400C 2054 (USART3)) bit description

Bit	Symbol	Description	Reset value
7:0	DLY	Contains the direction control delay value. This register works in conjunction with an 8-bit counter.	0x00
31:8	-	Reserved, user software should not write ones to reserved bits. The value read from a reserved bit is not defined.	NA

38.6.19 USART Synchronous mode control register

SYNCCTRL register is a Read/write register that controls the synchronous mode. The synchronous mode control module generates or receives the synchronous clock with the serial input/ output data and distributes the edge detect samples to the transmit and receive shift registers.

Table 867. USART Synchronous mode control registers (SYNCCTRL - address addresses 0x4008 1058 (USART0), 0x400C 1058 (USART2), 0x400C 2058 (USART3)) bit description

Bit	Symbol	Value	Description	Reset value
0	SYNC		Enables synchronous mode.	0
		0	Disabled	
		1	Enabled	
1	CSRC		Clock source select.	0
		0	Synchronous slave mode (SCLK in)	
		1	Synchronous master mode (SCLK out)	
2	FES		Falling edge sampling.	0
		0	RxD is sampled on the rising edge of SCLK	
		1	RxD is sampled on the falling edge of SCLK	
3	TSBYPASS		Transmit synchronization bypass in synchronous slave mode.	0
		0	The input clock is synchronized prior to being used in clock edge detection logic.	
		1	The input clock is not synchronized prior to being used in clock edge detection logic. This allows for a higher input clock rate at the expense of potential metastability.	
4	CSCEN		Continuous master clock enable (used only when CSRC is 1)	0
		0	SCLK cycles only when characters are being sent on TxD	
		1	SCLK runs continuously (characters can be received on RxD independently from transmission on TxD)	

Table 867. USART Synchronous mode control registers (SYNCCTRL - address addresses 0x4008 1058 (USART0), 0x400C 1058 (USART2), 0x400C 2058 (USART3)) bit description

Bit	Symbol	Value	Description	Reset value
5	SSDIS		Start/stop bits	0
		0	Send start and stop bits as in other modes.	
		1	Do not send start/stop bits.	
6	CCCLR		Continuous clock clear	0
		0	CSCEN is under software control.	
		1	Hardware clears CSCEN after each character is received.	
31:7	-		Reserved. The value read from a reserved bit is not defined.	NA

After reset, synchronous mode is disabled. Synchronous mode allows the user to send (synchronous master mode) or receive (synchronous slave mode) a clock with the serial input and output data. Synchronous mode is enabled by setting the SYNC bit. The CSRC bit can be used to switch between synchronous slave mode (logic 0) and synchronous master mode (logic 1). The serial data can either be sampled on the rising edge (default) or the falling edge of the serial clock. When the STARTSTOPDISABLE bit is set, the FES bit is hardware overwritten to sample on the falling edge.

A master clock is only required to generate a clock when transmitting data. In this case, data can only be received when data is transmitted. When the CSCEN bit is set, the clock will always be running (during synchronous master mode only), allowing data to be received continuously.

Note that this option should not be used in combination with STARTSTOPDISABLE (during full-duplex communication). The continuous clock can be automatically stopped by hardware after having received a complete character. This can be done by asserting the CCCLR bit. This is useful in half-duplex mode, where the clock cannot be generated by sending a character. After the reception of one character, the CSCEN bit is automatically cleared by hardware. When another character needs to be received, the CSCEN should be enabled again.

By default data transmission and reception performs the same in asynchronous mode and synchronous mode. When the STARTSTOPDISABLE bit is set, no start and stop bits are transmitted (nor are they received). This means that all bits that are send or received (a clock is running) are data bits.

Remark: The value of the SYNCCTRL register should not be modified while transmitting/receiving, data or data might get lost or corrupted.

Remark: The SYNCCTRL register should not be enabled in combination with the SICCTRL register, as only asynchronous smart card is supported.

38.6.20 USART Transmit Enable Register

In addition to being equipped with full hardware flow control (auto-cts and auto-rts mechanisms described above), TER enables implementation of software flow control. When TxEn = 1, USART transmitter will keep sending data as long as they are available. As soon as TxEn becomes 0, USART transmission will stop.

[Table 868](#) describes how to use TXEN bit in order to achieve software flow control.

Table 868. USART Transmit Enable Register (TER - addresses 0x4008 105C (USART0), 0x400C 105C (USART2), 0x400C 205C (USART3)) bit description

Bit	Symbol	Description	Reset value
0	TXEN	Transmit enable. After reset transmission is enabled. When the TXEN bit is de-asserted, no data will be transmitted although data may be pending in the TSR or THR.	1
31:1	-	Reserved, user software should not write ones to reserved bits. The value read from a reserved bit is not defined.	-

38.7 Functional description

38.7.1 Auto-baud

The USART auto-baud function can be used to measure the incoming baud rate based on the "AT" protocol (Hayes command). If enabled the auto-baud feature will measure the bit time of the receive data stream and set the divisor latch registers DLM and DLL accordingly.

Auto-baud is started by setting the ACR Start bit. Auto-baud can be stopped by clearing the ACR Start bit. The Start bit will clear once auto-baud has finished and reading the bit will return the status of auto-baud (pending/finished).

Two auto-baud measuring modes are available which can be selected by the ACR Mode bit. In Mode 0 the baud rate is measured on two subsequent falling edges of the USART Rx pin (the falling edge of the start bit and the falling edge of the least significant bit). In Mode 1 the baud rate is measured between the falling edge and the subsequent rising edge of the USART Rx pin (the length of the start bit).

The ACR AutoRestart bit can be used to automatically restart baud rate measurement if a time-out occurs (the rate measurement counter overflows). If this bit is set, the rate measurement will restart at the next falling edge of the USART Rx pin.

The auto-baud function can generate two interrupts.

- The IIR ABTOInt interrupt will get set if the interrupt is enabled (IER ABTOIntEn is set and the auto-baud rate measurement counter overflows).
- The IIR ABEOInt interrupt will get set if the interrupt is enabled (IER ABEOIntEn is set and the auto-baud has completed successfully).

The auto-baud interrupts have to be cleared by setting the corresponding ACR ABTOIntClr and ABEOIntEn bits.

The fractional baud rate generator must be disabled ($DIVADDVAL = 0$) during auto-baud. Also, when auto-baud is used, any write to DLM and DLL registers should be done before ACR register write. The minimum and the maximum baud rates supported by USART are function of $USART_PCLK$, number of data bits, stop bits and parity bits.

(7)

$$ratemin = \frac{2 \times PCLK}{16 \times 2^{15}} \leq USART_{baudrate} \leq \frac{PCLK}{16 \times (2 + databits + paritybits + stopbits)} = ratemax$$

38.7.2 Auto-baud modes

When the software is expecting an "AT" command, it configures the USART with the expected character format and sets the ACR Start bit. The initial values in the divisor latches DLM and DLL don't care. Because of the "A" or "a" ASCII coding ("A" = 0x41, "a" = 0x61), the USART Rx pin sensed start bit and the LSB of the expected character are delimited by two falling edges. When the ACR Start bit is set, the auto-baud protocol will execute the following phases:

1. On ACR Start bit setting, the baud rate measurement counter is reset and the USART RSR is reset. The RSR baud rate is switched to the highest rate.
2. A falling edge on USART Rx pin triggers the beginning of the start bit. The rate measuring counter will start counting $USART_PCLK$ cycles.
3. During the receipt of the start bit, 16 pulses are generated on the RSR baud input with the frequency of the USART input clock, guaranteeing the start bit is stored in the RSR.
4. During the receipt of the start bit (and the character LSB for Mode = 0), the rate counter will continue incrementing with the pre-scaled USART input clock ($USART_PCLK$).
5. If Mode = 0, the rate counter will stop on next falling edge of the USART Rx pin. If Mode = 1, the rate counter will stop on the next rising edge of the USART Rx pin.
6. The rate counter is loaded into DLM/DLL and the baud rate will be switched to normal operation. After setting the DLM/DLL, the end of auto-baud interrupt IIR ABEOInt will be set, if enabled. The RSR will now continue receiving the remaining bits of the "A/a" character.

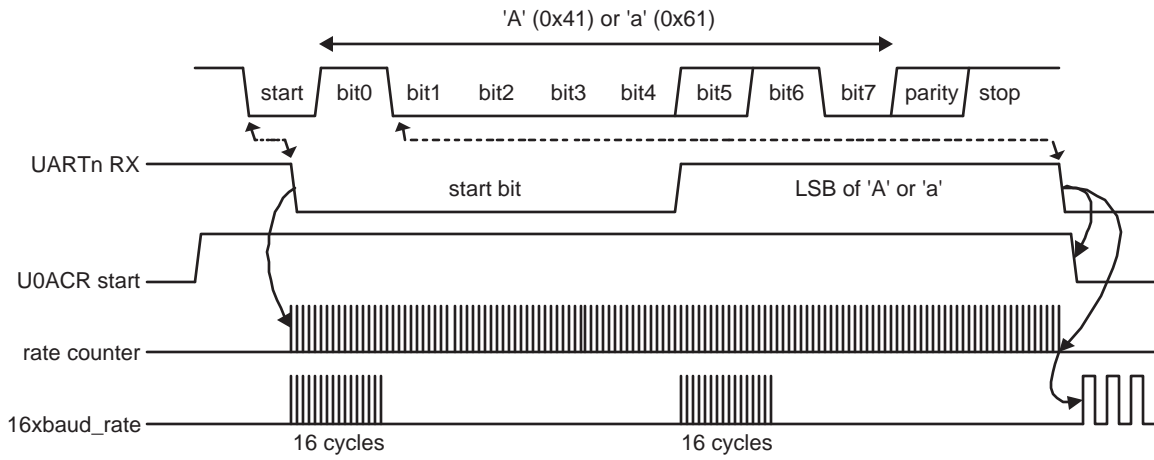

a. Mode 0 (start bit and LSB are used for auto-baud)

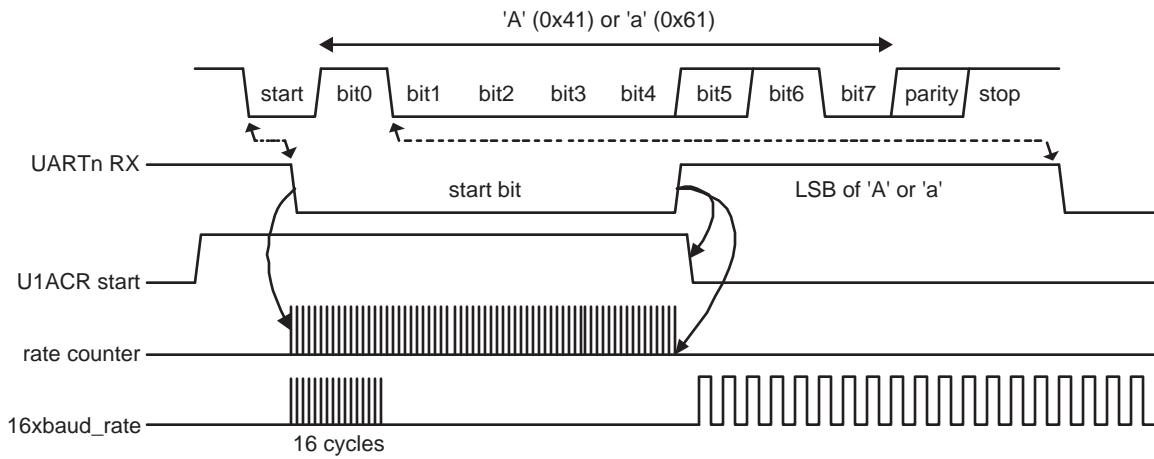

b. Mode 1 (only start bit is used for auto-baud)

Fig 116. Auto-baud a) mode 0 and b) mode 1 waveform

38.7.3 Baud rate calculation in asynchronous mode

USART can operate with or without using the Fractional Divider. In real-life applications it is likely that the desired baud rate can be achieved using several different Fractional Divider settings. The following algorithm illustrates one way of finding a set of DLM, DLL, MULVAL, and DIVADDVAL values. Such set of parameters yields a baud rate with a relative error of less than 1.1% from the desired one.

The USART baud rate can be calculated as:

(8)

$$UART_{baudrate} = \frac{PCLK}{16 \times (256 \times DLM + DLL) \times \left(1 + \frac{DivAddVal}{MulVal}\right)}$$

Where USART_PCLK is the peripheral clock, DLM and DLL are the standard USART baud rate divider registers, and DIVADDVAL and MULVAL are USART fractional baud rate generator specific parameters.

The value of MULVAL and DIVADDVAL should comply to the following conditions:

1. $1 \leq MULVAL \leq 15$
2. $0 \leq DIVADDVAL \leq 14$
3. $DIVADDVAL < MULVAL$

The value of the FDR should not be modified while transmitting/receiving data or data may be lost or corrupted.

If the FDR register value does not comply to these two requests, then the fractional divider output is undefined. If DIVADDVAL is zero then the fractional divider is disabled, and the clock will not be divided.

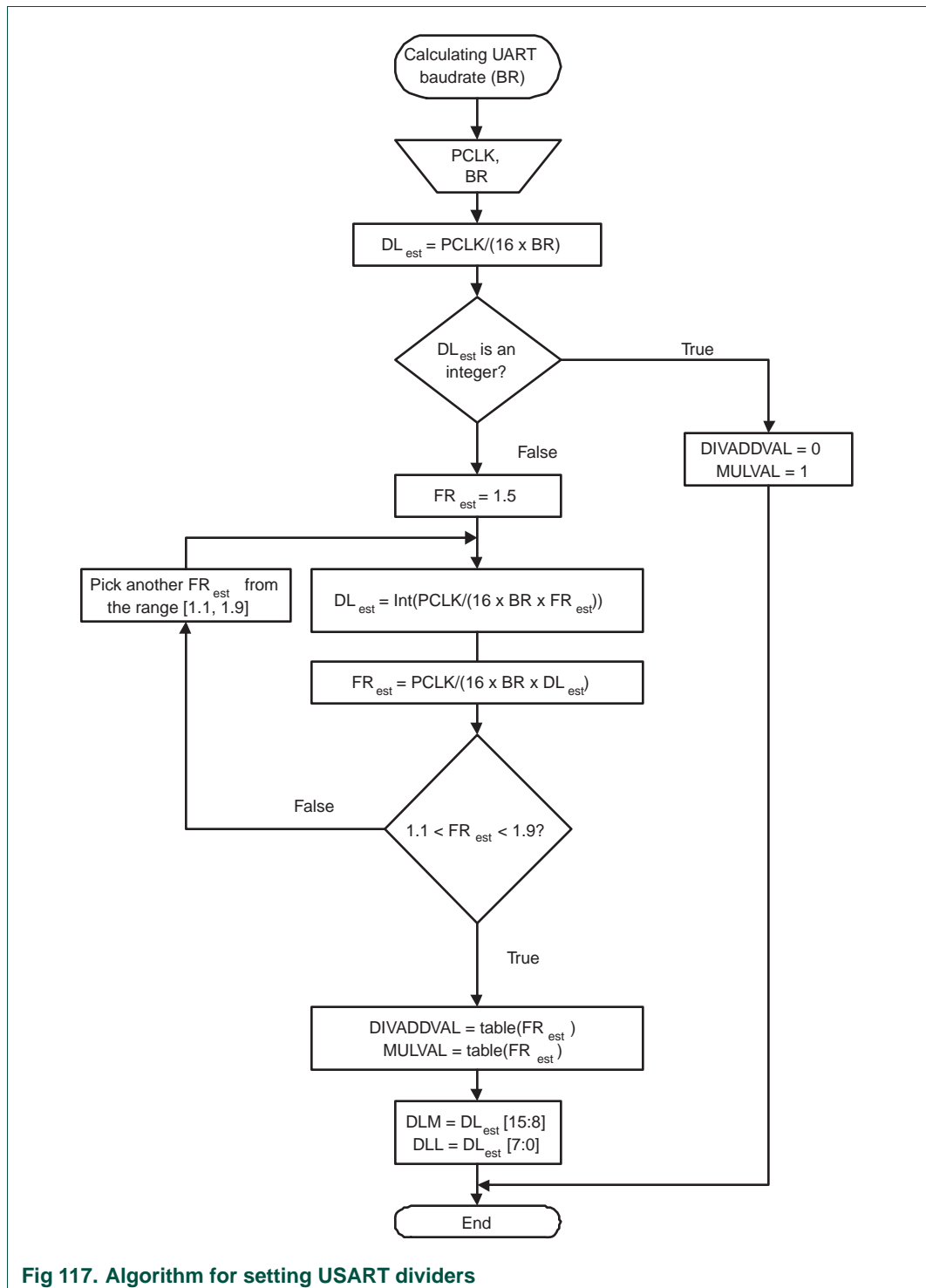

Fig 117. Algorithm for setting USART dividers

Table 869. Fractional Divider setting look-up table

FR	DivAddVal/ MulVal	FR	DivAddVal/ MulVal	FR	DivAddVal/ MulVal	FR	DivAddVal/ MulVal
1.000	0/1	1.250	1/4	1.500	1/2	1.750	3/4
1.067	1/15	1.267	4/15	1.533	8/15	1.769	10/13
1.071	1/14	1.273	3/11	1.538	7/13	1.778	7/9
1.077	1/13	1.286	2/7	1.545	6/11	1.786	11/14
1.083	1/12	1.300	3/10	1.556	5/9	1.800	4/5
1.091	1/11	1.308	4/13	1.571	4/7	1.818	9/11
1.100	1/10	1.333	1/3	1.583	7/12	1.833	5/6
1.111	1/9	1.357	5/14	1.600	3/5	1.846	11/13
1.125	1/8	1.364	4/11	1.615	8/13	1.857	6/7
1.133	2/15	1.375	3/8	1.625	5/8	1.867	13/15
1.143	1/7	1.385	5/13	1.636	7/11	1.875	7/8
1.154	2/13	1.400	2/5	1.643	9/14	1.889	8/9
1.167	1/6	1.417	5/12	1.667	2/3	1.900	9/10
1.182	2/11	1.429	3/7	1.692	9/13	1.909	10/11
1.200	1/5	1.444	4/9	1.700	7/10	1.917	11/12
1.214	3/14	1.455	5/11	1.714	5/7	1.923	12/13
1.222	2/9	1.462	6/13	1.727	8/11	1.929	13/14
1.231	3/13	1.467	7/15	1.733	11/15	1.933	14/15

38.7.3.1 Example 1: USART_PCLK = 14.7456 MHz, BR = 9600

According to the provided algorithm $DL_{est} = PCLK / (16 \times BR) = 14.7456 \text{ MHz} / (16 \times 9600) = 96$. Since this DL_{est} is an integer number, $DIVADDVAL = 0$, $MULVAL = 1$, $DLM = 0$, and $DLL = 96$.

38.7.3.2 Example 2: USART_PCLK = 12 MHz, BR = 115200

According to the provided algorithm $DL_{est} = PCLK / (16 \times BR) = 12 \text{ MHz} / (16 \times 115200) = 6.51$. This DL_{est} is not an integer number and the next step is to estimate the FR parameter. Using an initial estimate of $FR_{est} = 1.5$ a new $DL_{est} = 4$ is calculated and FR_{est} is recalculated as $FR_{est} = 1.628$. Since $FR_{est} = 1.628$ is within the specified range of 1.1 and 1.9, $DIVADDVAL$ and $MULVAL$ values can be obtained from the attached look-up table.

The closest value for $FR_{est} = 1.628$ in the look-up [Table 869](#) is $FR = 1.625$. It is equivalent to $DIVADDVAL = 5$ and $MULVAL = 8$.

Based on these findings, the suggested USART setup would be: $DLM = 0$, $DLL = 4$, $DIVADDVAL = 5$, and $MULVAL = 8$. According to [Equation 6](#), the USART's baud rate is 115384. This rate has a relative error of 0.16% from the originally specified 115200.

38.7.4 RS-485/EIA-485 modes of operation

The RS-485/EIA-485 feature allows the USART to be configured as an addressable slave. The addressable slave is one of multiple slaves controlled by a single master.

The USART master transmitter will identify an address character by setting the parity (9th) bit to '1'. For data characters, the parity bit is set to '0'.

Each USART slave receiver can be assigned a unique address. The slave can be programmed to either manually or automatically reject data following an address which is not theirs.

RS-485/EIA-485 Normal Multidrop Mode (NMM)

Setting the RS485CTRL bit 0 enables this mode. In this mode, an address is detected when a received byte causes the USART to set the parity error and generate an interrupt.

If the receiver is disabled (RS485CTRL bit 1 = '1'), any received data bytes will be ignored and will not be stored in the RXFIFO. When an address byte is detected (parity bit = '1') it will be placed into the RXFIFO and an Rx Data Ready Interrupt will be generated. The processor can then read the address byte and decide whether or not to enable the receiver to accept the following data.

While the receiver is enabled (RS485CTRL bit 1 = '0'), all received bytes will be accepted and stored in the RXFIFO regardless of whether they are data or address. When an address character is received a parity error interrupt will be generated and the processor can decide whether or not to disable the receiver.

RS-485/EIA-485 Auto Address Detection (AAD) mode

When both RS485CTRL register bits 0 (9-bit mode enable) and 2 (AAD mode enable) are set, the USART is in auto address detect mode.

In this mode, the receiver will compare any address byte received (parity = '1') to the 8-bit value programmed into the RS485ADRMATCH register.

If the receiver is disabled (RS485CTRL bit 1 = '1'), any received byte will be discarded if it is either a data byte OR an address byte which fails to match the RS485ADRMATCH value.

When a matching address character is detected it will be pushed onto the RXFIFO along with the parity bit, and the receiver will be automatically enabled (RS485CTRL bit 1 will be cleared by hardware). The receiver will also generate an Rx Data Ready Interrupt.

While the receiver is enabled (RS485CTRL bit 1 = '0'), all bytes received will be accepted and stored in the RXFIFO until an address byte which does not match the RS485ADRMATCH value is received. When this occurs, the receiver will be automatically disabled in hardware (RS485CTRL bit 1 will be set), The received non-matching address character will not be stored in the RXFIFO.

RS-485/EIA-485 Auto Direction Control

RS485/EIA-485 mode includes the option of allowing the transmitter to automatically control the state of the DIR pin as a direction control output signal.

Setting RS485CTRL bit 4 = '1' enables this feature.

When Auto Direction Control is enabled, the selected pin will be asserted (driven LOW) when the CPU writes data into the TXFIFO. The pin will be de-asserted (driven HIGH) once the last bit of data has been transmitted. See bits 4 and 5 in the RS485CTRL register.

The RS485CTRL bit 4 takes precedence over all other mechanisms controlling the direction control pin.

RS485/EIA-485 driver delay time

The driver delay time is the delay between the last stop bit leaving the TXFIFO and the de-assertion of the DIR pin. This delay time can be programmed in the 8-bit RS485DLY register. The delay time is in periods of the baud clock. Any delay time from 0 to 255 bit times may be used.

RS485/EIA-485 output inversion

The polarity of the direction control signal on the DIR pin can be reversed by programming bit 5 in the RS485CTRL register. When this bit is set, the direction control pin will be driven to logic 1 when the transmitter has data waiting to be sent. The direction control pin will be driven to logic 0 after the last bit of data has been transmitted.

38.7.5 Synchronous mode

When the synchronous receiver/ transmitter feature is configured (USART), the serial interface is extended with a serial input and output clock and an output enable for controlling the clock pad.

By default transmission and reception in synchronous mode operates uses the same protocol as in asynchronous mode. Synchronous mode can be configured using the Synchronous Mode Control Register. This register allows to control:

- The direction of the serial clock, i.e. synchronous slave or master mode
- The sampling edge of the serial clock
- Two-stage or one stage synchronization of the input serial clock during transmission
- During synchronous master mode, the clock can be continuous or disabled when in idle or break mode
- The transmission of start and stop bits can be omitted. Valid data is identified by a running clock. Sampling is always done on the falling edge of the serial clock

Data is shifted in the receive shift register at the sampling edge of the serial clock.

38.7.5.1 USART clock in synchronous mode

In synchronous master mode, the USART synchronous clock is determined as follows:

$$U_n_UCLK = \frac{\text{BASE_UARTn_CLK}}{2 \times (256 \times DLM + DLL) \times \left(1 + \frac{DIVADDVAL}{MULVAL}\right)} \quad (9)$$

DLM and DLL are the standard USART0 baud rate divider registers, and DIVADDVAL and MULVAL are USART0 fractional baud rate generator specific parameters. Setting DIVADDVAL = 0 disables the fractional baud rate generator.

38.7.5.2 Synchronous slave mode

This mode is enabled by setting the CSRC bit of the control register to '0'. During synchronous slave mode, an external clock is required that clocks the serial input and output data. Note that internally, the serial clock is treated as a data signal. Edge detection on the serial clock is performed to synchronize the serial clock with the USART clock domain, hence no registers are clocked with the serial clock.

Reception

By default the received character is similar to the character in asynchronous mode. The serial data stream is kept HIGH when no data is available. During this time it is not required for the external serial clock to be running. The first bit that will be received is the start bit. During this time, the external serial clock must be running. The beginning of the start bit can either be aligned with the rising edge of the serial clock (sampling on the falling edge) or the falling edge (sampling on the rising edge), see the FES bit in [Table 867](#). When sampling on the rising edge, it is not required that the beginning of the start bit is aligned with a clock edge (the clock may not have been running before). In this case, the edge on the serial input data due to the start bit (logic 1 to 0) is used to determine the start of the character.

The NOSTARTSTOPBITS bit of the Synchronous Mode Control register allows the user to disable the transmission/ reception of the start and stop bits, improving the efficiency of the USART. As a character is no longer identified by the start and stop bits, the serial clock is used to determine the data bits. When the serial clock is running, all data that is sampled is regarded as valid data.

In order to be able to identify the start of a character, the beginning of the character must be aligned with the rising edge of the serial clock. For this reason, the FES bit of the Synchronous Mode Control register is forced in hardware to '1'.

Directly after sampling the last bit, the character is stored in the receive FIFO.

Transmission

During synchronous slave mode, data can only be transmitted when the external serial clock is running. Hence, when no start and stop bits are sent, transmission can only take place when data is received from the master. When the start and stop bits are transmitted, the external clock may only be detected after the first half of the received start bit (sampling at the rising edge of the external serial clock). By using the edge created by the received start bit (logic 1 to 0), it is made sure that the start bit of the character that is to be transmitted by the slave is stable before this rising edge the external slave clock. In this way it is ensured, that the master receives as many bits as it has transmitted.

When the first sample edge of the incoming serial clock samples a '1' on the serial input data (and start-stop bits are transmitted, thus the master has not initiated a transaction yet), it is assumed that the master is running a continuous clock (instead of only running the clock when sending data characters). The USART will not wait for a start bit from the master, but will immediately start transmitting data when available. Note that in this situation, the number of bits transmitted by the master and the number of bits transmitted by the slave (received by the master) may not be aligned. It is assumed that a higher level protocol ensures that complete characters are received when the master stops the clock.

Transmission of data during synchronous slave mode is most time-critical. First the external serial input clock must be detected using edge detection logic. Then, data needs to be shifted out and be stable before the sampling edge of the external serial clock.

Remark: In this mode the u_clk period is allowed to be 4x the serial clock period.

38.7.5.3 Synchronous master mode

Synchronous master mode is enabled by setting the CSRC register bit to '1'. In this mode, the external clock is generated internally by the baud-rate generation logic and is used to clock the input and output serial data. The functionality of the baud-rate generation is described in [Section 38.7.3](#). Auto-baud is not supported during synchronous mode. The 1x baud rate clock is used to shift out the serial output data and to sample the serial input data.

Synchronous master mode behaves similar to the slave mode, except that the serial input data is not registered at the interface but is clocked in the USART clock domain at the sampling edge of the serial clock.

During synchronous master mode, when start and stop bits are transmitted, the user can enable the external clock continuously using cscen bit of the Synchronous Mode Control register. This allows the connected slave to transmit data even when no data is transmitted by the master itself.

38.7.6 Smart card mode

[Figure 118](#) shows a typical asynchronous smart card application.

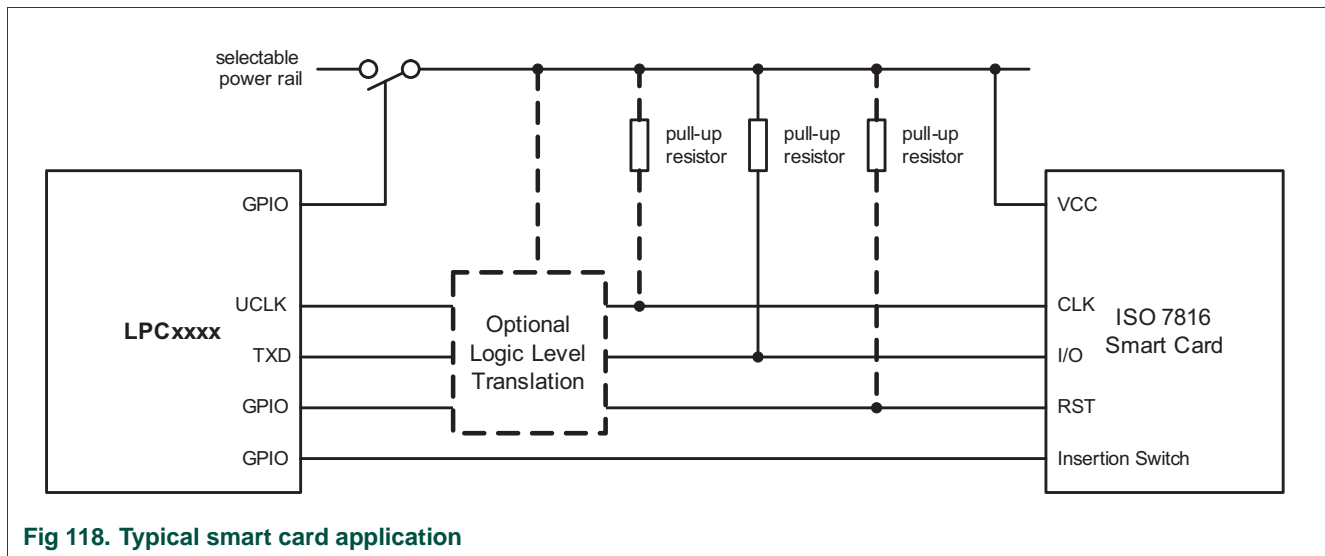

Fig 118. Typical smart card application

When the SCIEN bit in the SCICTRL register ([Table 863](#)) is set as described above, the USART provides bidirectional serial data on the open-drain TXD pin. No RXD pin is used when SCIEN is 1. The USART UCLK pin will output synchronously with the data at the data bit rate. Software must use timers to implement character and block waiting times (no hardware support via trigger signals is provided on this part). GPIO pins can be used to control the smart card reset and power pins. Any power supplied to the card must be externally switched as card power supply requirements often exceed source currents possible on this part. As the specific application may accommodate any of the available

ISO 7816 class A, B, or C power requirements, be aware of the logic level tolerances and requirements when communicating or powering cards that use different power rails than this part.

38.7.6.1 Smart card set-up procedure

A T = 0 protocol transfer consists of 8-bits of data, an even parity bit, and two guard bits that allow for the receiver of the particular transfer to flag parity errors through the NACK response (see [Figure 119](#)). Extra guard bits may be added according to card requirements. If no NACK is sent (provided the interface accepts them in SCICTRL), the next byte may be transmitted immediately after the last guard bit. If the NACK is sent, the transmitter will retry sending the byte until successfully received or until the SCICTRL retry limit has been met.

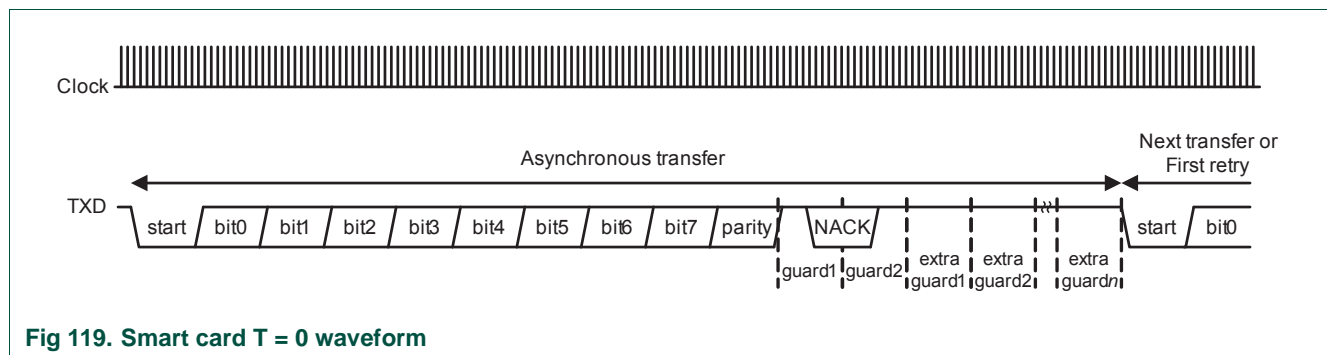

Fig 119. Smart card T = 0 waveform

The smart card must be set up with the following considerations:

1. If necessary, bring the USART out of reset and enable clocking to the peripheral.
2. Setup an available USART TXD pin for the bidirectional transfers.
3. Set up the UCLK pip as the clock source using the pin configuration registers. The default clock requirement for most asynchronous cards is 372 times the bit rate.
4. Configure DLL and DLM for baud rate. It may not be necessary to target a specific standard baud rate but rather to maintain a fraction of the previously mentioned clock rate. For example if the clock rate is set to 4 MHz the baud rate would be 10753. A clock rate of 3.5712 MHz would need a baud rate of 9600. An ISO 7816 PPS exchange may require the baud rate to be changed later.
5. Configure LCR for character size and parity (typically 8-bit and even parity).
6. Configure SCICTRL with the desired NACK response, extra guard bits, and protocol type.
7. Place the GPIO output signals into an inactive state where card power is off, RST is low, and CLK is low and unchanging.

Thereafter, software should monitor card insertion, handle activation, wait for answer to reset as described in ISO7816-3.

39.1 How to read this chapter

The UART1 controller is available on all LPC18xx parts.

39.2 Basic configuration

The UART1 is configured as follows:

- See [Table 870](#) for clocking and power control.
- The UART1 is reset by the UART1_RST (reset #45).
- The UART1 interrupt is connected to slot # 25 in the NVIC.
- For connecting the UART1 receive and transmit lines to the GPDMA, use the DMAMUX register in the CREG block (see [Table 96](#)).

Table 870. UART1 clocking and power control

	Base clock	Branch clock	Operating frequency
UART1 clock to register interface	BASE_M3_CLK	CLK_M3_UART1	up to 180 MHz
UART1 peripheral clock (PCLK)	BASE_UART1_CLK	CLK_APB0_UART1	up to 180 MHz

39.3 Features

- Full modem control handshaking available.
- Data sizes of 5, 6, 7, and 8 bits.
- Parity generation and checking: odd, even mark, space or none.
- One or two stop bits.
- 16 byte Receive and Transmit FIFOs.
- Built-in baud rate generator, including a fractional rate divider for great versatility.
- Supports DMA for both transmit and receive.
- Auto-baud capability.
- Break generation and detection.
- Multiprocessor addressing mode.
- RS-485 support.

39.4 General description

The architecture of the UART1 is shown below in the block diagram.

The APB interface provides a communications link between the CPU or host and the UART1.

The UART1 receiver block, RX, monitors the serial input line, RXD, for valid input. The UART1 RX Shift Register (RSR) accepts valid characters via RXD. After a valid character is assembled in the RSR, it is passed to the UART1 RX Buffer Register FIFO to await access by the CPU or host via the generic host interface.

The UART1 transmitter block, TX, accepts data written by the CPU or host and buffers the data in the UART1 TX Holding Register FIFO (THR). The UART1 TX Shift Register (TSR) reads the data stored in the THR and assembles the data to transmit via the serial output pin, TXD1.

The UART1 Baud Rate Generator block, BRG, generates the timing enables used by the UART1 TX and RX blocks. The BRG clock input source is the APB clock (PCLK). The main clock is divided down per the divisor specified in the DLL and DLM registers. This divided down clock is a 16x oversample clock, NBAUDOUT.

The modem interface contains registers MCR and MSR. This interface is responsible for handshaking between a modem peripheral and the UART1.

The interrupt interface contains registers IER and IIR. The interrupt interface receives several one clock wide enables from the TX and RX blocks.

Status information from the TX and RX is stored in the LSR. Control information for the TX and RX is stored in the LCR.

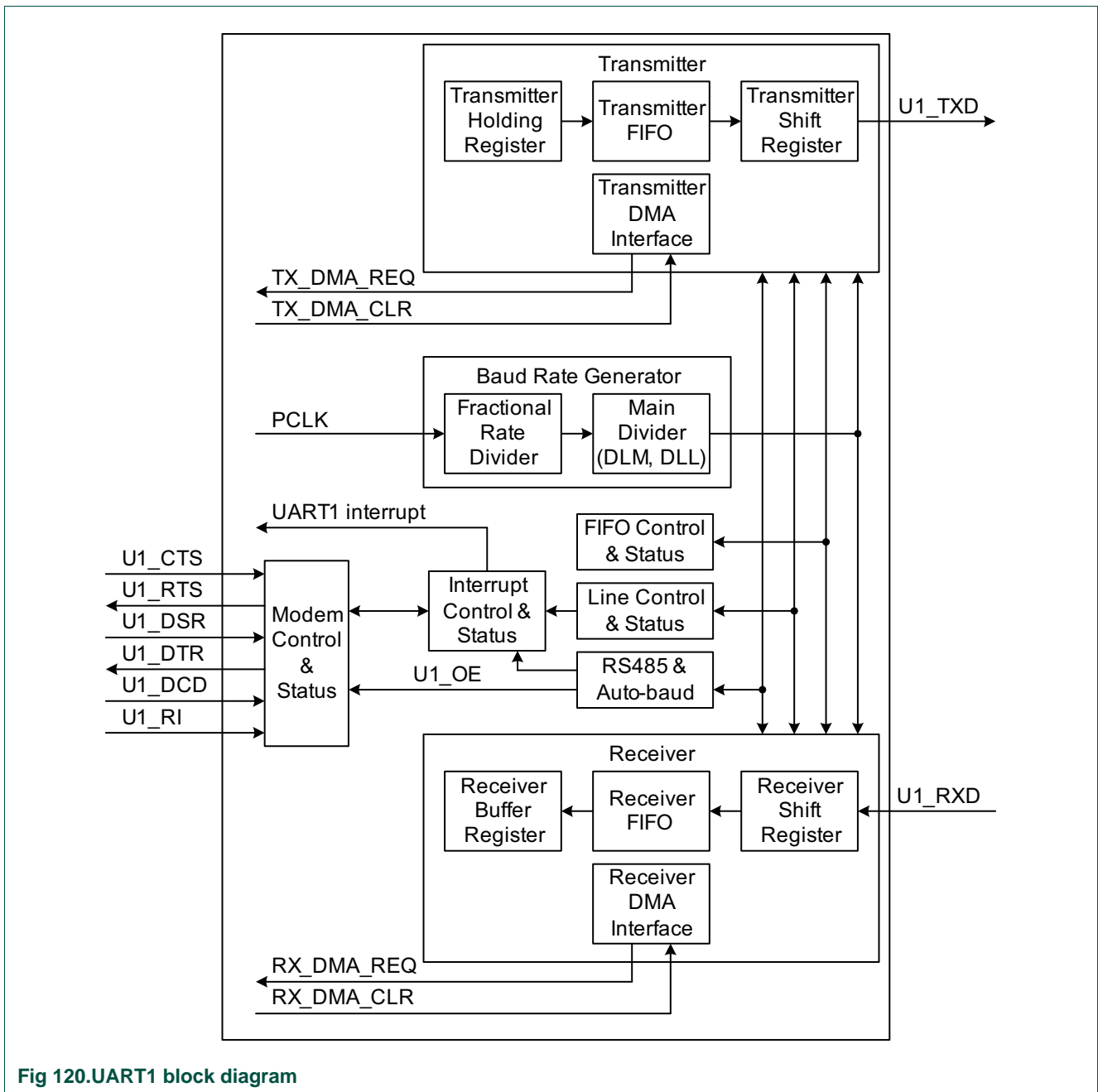

Fig 120. UART1 block diagram

39.5 Pin description

Table 871: UART1 Pin description

Pin function	Direction	Description
U1_RXD	Input	Serial Input. Serial receive data.
U1_TXD	Output	Serial Output. Serial transmit data.
U1_CTS	Input	<p>Clear To Send. Active low signal indicates if the external modem is ready to accept transmitted data via TXD from the UART1. In normal operation of the modem interface (MCR[4] = 0), the complement value of this signal is stored in MSR[4]. State change information is stored in MSR[0] and is a source for a priority level 4 interrupt, if enabled (IER[3] = 1).</p> <p>Clear to send. CTS is an asynchronous, active low modem status signal. Its condition can be checked by reading bit 4 (CTS) of the modem status register. Bit 0 (DCTS) of the Modem Status Register (MSR) indicates that CTS has changed states since the last read from the MSR. If the modem status interrupt is enabled when CTS changes levels and the auto-cts mode is not enabled, an interrupt is generated. CTS is also used in the auto-cts mode to control the transmitter.</p>
U1_DCD	Input	<p>Data Carrier Detect. Active low signal indicates if the external modem has established a communication link with the UART1 and data may be exchanged. In normal operation of the modem interface (MCR[4]=0), the complement value of this signal is stored in MSR[7]. State change information is stored in MSR3 and is a source for a priority level 4 interrupt, if enabled (IER[3] = 1).</p>
U1_DSR	Input	<p>Data Set Ready. Active low signal indicates if the external modem is ready to establish a communications link with the UART1. In normal operation of the modem interface (MCR[4] = 0), the complement value of this signal is stored in MSR[5]. State change information is stored in MSR[1] and is a source for a priority level 4 interrupt, if enabled (IER[3] = 1).</p>
U1_DTR	Output	<p>Data Terminal Ready. Active low signal indicates that the UART1 is ready to establish connection with external modem. The complement value of this signal is stored in MCR[0].</p> <p>The DTR pin can also be used as an RS-485/EIA-485 output enable signal.</p>
U1_RI	Input	<p>Ring Indicator. Active low signal indicates that a telephone ringing signal has been detected by the modem. In normal operation of the modem interface (MCR[4] = 0), the complement value of this signal is stored in MSR[6]. State change information is stored in MSR[2] and is a source for a priority level 4 interrupt, if enabled (IER[3] = 1).</p>
U1_RTS	Output	<p>Request To Send. Active low signal indicates that the UART1 would like to transmit data to the external modem. The complement value of this signal is stored in MCR[1].</p> <p>In auto-rts mode, RTS is used to control the transmitter FIFO threshold logic.</p> <p>Request to send. RTS is an active low signal informing the modem or data set that the UART is ready to receive data. RTS is set to the active (low) level by setting the RTS modem control register bit and is set to the inactive (high) level either as a result of a system reset or during loop-back mode operations or by clearing bit 1 (RTS) of the MCR. In the auto-rts mode, RTS is controlled by the transmitter FIFO threshold logic.</p> <p>The RTS pin can also be used as an RS-485/EIA-485 output enable signal.</p>

39.6 Register description

UART1 contains registers organized as shown in [Table 872](#). The Divisor Latch Access Bit (DLAB) is contained in LCR[7] and enables access to the Divisor Latches.

Reset value reflects the data stored in used bits only. It does not include the content of reserved bits.

Table 872: Register overview: UART1 (base address 0x4008 2000)

Name	Access	Address offset	Description	Reset value	Reference
RBR	RO	0x000	Receiver Buffer Register. Contains the next received character to be read. (DLAB=0)	NA	Table 873
THR	WO	0x000	Transmit Holding Register. The next character to be transmitted is written here. (DLAB=0)	NA	Table 874
DLL	R/W	0x000	Divisor Latch LSB. Least significant byte of the baud rate divisor value. The full divisor is used to generate a baud rate from the fractional rate divider. (DLAB=1)	0x01	Table 875
DLM	R/W	0x004	Divisor Latch MSB. Most significant byte of the baud rate divisor value. The full divisor is used to generate a baud rate from the fractional rate divider.(DLAB=1)	0x00	Table 876
IER	R/W	0x004	Interrupt Enable Register. Contains individual interrupt enable bits for the 7 potential UART1 interrupts. (DLAB=0)	0x00	Table 877
IIR	RO	0x008	Interrupt ID Register. Identifies which interrupt(s) are pending.	0x01	Table 878
FCR	WO	0x008	FIFO Control Register. Controls UART1 FIFO usage and modes.	0x00	Table 880
LCR	R/W	0x00C	Line Control Register. Contains controls for frame formatting and break generation.	0x00	Table 881
MCR	R/W	0x010	Modem Control Register. Contains controls for flow control handshaking and loopback mode.	0x00	Table 882
LSR	RO	0x014	Line Status Register. Contains flags for transmit and receive status, including line errors.	0x60	Table 883
MSR	RO	0x018	Modem Status Register. Contains handshake signal status flags.	0x00	Table 884
SCR	R/W	0x01C	Scratch Pad Register. 8-bit temporary storage for software.	0x00	Table 885
ACR	R/W	0x020	Auto-baud Control Register. Contains controls for the auto-baud feature.	0x00	Table 886
FDR	R/W	0x028	Fractional Divider Register. Generates a clock input for the baud rate divider.	0x10	Table 887
RS485CTRL	R/W	0x04C	RS-485/EIA-485 Control. Contains controls to configure various aspects of RS-485/EIA-485 modes.	0x00	Table 888
RS485ADRMATCH	R/W	0x050	RS-485/EIA-485 address match. Contains the address match value for RS-485/EIA-485 mode.	0x00	Table 889
RS485DLY	R/W	0x054	RS-485/EIA-485 direction control delay.	0x00	Table 890
TER	R/W	0x05C	Transmit Enable Register. Turns off UART transmitter for use with software flow control.	0x01	Table 891

39.6.1 UART1 Receiver Buffer Register (when DLAB = 0)

The RBR is the top byte of the UART1 RX FIFO. The top byte of the RX FIFO contains the oldest character received and can be read via the bus interface. The LSB (bit 0) represents the “oldest” received data bit. If the character received is less than 8 bits, the unused MSBs are padded with zeroes.

The Divisor Latch Access Bit (DLAB) in LCR must be zero in order to access the RBR. The RBR is always read-only.

Since PE, FE and BI bits correspond to the byte sitting on the top of the RBR FIFO (i.e. the one that will be read in the next read from the RBR), the right approach for fetching the valid pair of received byte and its status bits is first to read the content of the LSR register, and then to read a byte from the RBR.

Table 873: UART1 Receiver Buffer Register when DLAB = 0 (RBR - address 0x4008 2000) bit description

Bit	Symbol	Description	Reset value
7:0	RBR	Receiver Buffer. Contains the oldest received byte in the UART1 RX FIFO.	undefined
31:8	-	Reserved, the value read from a reserved bit is not defined.	NA

39.6.2 UART1 Transmitter Holding Register (when DLAB = 0)

The write-only THR is the top byte of the UART1 TX FIFO. The top byte is the newest character in the TX FIFO and can be written via the bus interface. The LSB represents the first bit to transmit.

The Divisor Latch Access Bit (DLAB) in LCR must be zero in order to access the THR. The THR is write-only.

Table 874: UART1 Transmitter Holding Register when DLAB = 0 (THR - address 0x4008 2000) bit description

Bit	Symbol	Description	Reset value
7:0	THR	Transmit Holding Register. Writing to the UART1 Transmit Holding Register causes the data to be stored in the UART1 transmit FIFO. The byte will be sent when it reaches the bottom of the FIFO and the transmitter is available.	NA
31:8	-	Reserved, user software should not write ones to reserved bits.	NA

39.6.3 UART1 Divisor Latch LSB and MSB Registers (when DLAB = 1)

The UART1 Divisor Latch is part of the UART1 Baud Rate Generator and holds the value used, along with the Fractional Divider, to divide the APB clock (PCLK) in order to produce the baud rate clock, which must be 16x the desired baud rate. The DLL and DLM registers together form a 16-bit divisor where DLL contains the lower 8 bits of the divisor and DLM contains the higher 8 bits of the divisor. A 0x0000 value is treated like a 0x0001 value as division by zero is not allowed. The Divisor Latch Access Bit (DLAB) in LCR must be one in order to access the UART1 Divisor Latches. Details on how to select the right value for DLL and DLM can be found later in this chapter, see [Section 39.6.13](#).

Table 875: UART1 Divisor Latch LSB Register when DLAB = 1 (DLL - address 0x4008 2000) bit description

Bit	Symbol	Description	Reset value
7:0	DLLSB	Divisor Latch LSB. The UART1 Divisor Latch LSB Register, along with the DLM register, determines the baud rate of the UART1.	0x01
31:8	-	Reserved, user software should not write ones to reserved bits. The value read from a reserved bit is not defined.	NA

Table 876: UART1 Divisor Latch MSB Register when DLAB = 1 (DLM - address 0x4008 2004) bit description

Bit	Symbol	Description	Reset value
7:0	DLMSB	Divisor Latch MSB. The UART1 Divisor Latch MSB Register, along with the DLL register, determines the baud rate of the UART1.	0x00
31:8	-	Reserved, user software should not write ones to reserved bits. The value read from a reserved bit is not defined.	NA

39.6.4 UART1 Interrupt Enable Register (when DLAB = 0)

The IER is used to enable the four UART1 interrupt sources.

Table 877: UART1 Interrupt Enable Register when DLAB = 0 (IER - address 0x4008 2004) bit description

Bit	Symbol	Value	Description	Reset value
0	RBRIE		RBR Interrupt Enable. Enables the Receive Data Available interrupt for UART1. It also controls the Character Receive Time-out interrupt.	0
		0	Disable the RDA interrupts.	
		1	Enable the RDA interrupts.	
1	THREIE		THRE Interrupt Enable. Enables the THRE interrupt for UART1. The status of this interrupt can be read from LSR[5].	0
		0	Disable the THRE interrupts.	
		1	Enable the THRE interrupts.	
2	RXIE		RX Line Interrupt Enable. Enables the UART1 RX line status interrupts. The status of this interrupt can be read from LSR[4:1].	0
		0	Disable the RX line status interrupts.	
		1	Enable the RX line status interrupts.	
3	MSIE		Modem Status Interrupt Enable. Enables the modem interrupt. The status of this interrupt can be read from MSR[3:0].	0
		0	Disable the modem interrupt.	
		1	Enable the modem interrupt.	
6:4	-		Reserved, user software should not write ones to reserved bits. The value read from a reserved bit is not defined.	NA

Table 877: UART1 Interrupt Enable Register when DLAB = 0 (IER - address 0x4008 2004) bit description

Bit	Symbol	Value	Description	Reset value
7	CTSIE		CTS Interrupt Enable. If auto-cts mode is enabled this bit enables/disables the modem status interrupt generation on a CTS1 signal transition. If auto-cts mode is disabled a CTS1 transition will generate an interrupt if Modem Status Interrupt Enable (IER[3]) is set. In normal operation a CTS1 signal transition will generate a Modem Status Interrupt unless the interrupt has been disabled by clearing the IER[3] bit in the IER register. In auto-cts mode a transition on the CTS1 bit will trigger an interrupt only if both the IER[3] and IER[7] bits are set.	0
		0	Disable the CTS interrupt.	
		1	Enable the CTS interrupt.	
8	ABEOIE		Enables the end of auto-baud interrupt.	0
		0	Disable end of auto-baud Interrupt.	
		1	Enable end of auto-baud Interrupt.	
9	ABTOIE		Enables the auto-baud time-out interrupt.	0
		0	Disable auto-baud time-out Interrupt.	
		1	Enable auto-baud time-out Interrupt.	
31:10	-		Reserved, user software should not write ones to reserved bits. The value read from a reserved bit is not defined.	NA

39.6.5 UART1 Interrupt Identification Register

The IIR provides a status code that denotes the priority and source of a pending interrupt. The interrupts are frozen during an IIR access. If an interrupt occurs during an IIR access, the interrupt is recorded for the next IIR access.

Table 878: UART1 Interrupt Identification Register (IIR - address 0x4008 2008) bit description

Bit	Symbol	Value	Description	Reset value
0	INTSTATUS		Interrupt status. Note that IIR[0] is active low. The pending interrupt can be determined by evaluating IIR[3:1].	1
		0	At least one interrupt is pending.	
		1	No interrupt is pending.	
3:1	INTID		Interrupt identification. IER[3:1] identifies an interrupt corresponding to the UART1 Rx or TX FIFO. All other combinations of IER[3:1] not listed below are reserved (100,101,111).	0
		0x3	1 - Receive Line Status (RLS).	
		0x2	2a - Receive Data Available (RDA).	
		0x6	2b - Character Time-out Indicator (CTI).	
		0x1	3 - THRE Interrupt.	
		0x0	4 - Modem Interrupt.	
5:4	-		Reserved, user software should not write ones to reserved bits. The value read from a reserved bit is not defined.	NA
7:6	FIFOENAB E		Copies of FCR[0].	0

Table 878: UART1 Interrupt Identification Register (IIR - address 0x4008 2008) bit description

Bit	Symbol	Value	Description	Reset value
8	ABEOINT		End of auto-baud interrupt. True if auto-baud has finished successfully and interrupt is enabled.	0
9	ABTOINT		Auto-baud time-out interrupt. True if auto-baud has timed out and interrupt is enabled.	0
31:10	-		Reserved, the value read from a reserved bit is not defined.	NA

Bit IIR[9:8] are set by the auto-baud function and signal a time-out or end of auto-baud condition. The auto-baud interrupt conditions are cleared by setting the corresponding Clear bits in the Auto-baud Control Register.

If the IntStatus bit is 1 no interrupt is pending and the IntId bits will be zero. If the IntStatus is 0, a non auto-baud interrupt is pending in which case the IntId bits identify the type of interrupt and handling as described in [Table 879](#). Given the status of IIR[3:0], an interrupt handler routine can determine the cause of the interrupt and how to clear the active interrupt. The IIR must be read in order to clear the interrupt prior to exiting the Interrupt Service Routine.

The UART1 RLS interrupt (IIR[3:1] = 011) is the highest priority interrupt and is set whenever any one of four error conditions occur on the UART1RX input: overrun error (OE), parity error (PE), framing error (FE) and break interrupt (BI). The UART1 Rx error condition that set the interrupt can be observed via LSR[4:1]. The interrupt is cleared upon an LSR read.

The UART1 RDA interrupt (IIR[3:1] = 010) shares the second level priority with the CTI interrupt (IIR[3:1] = 110). The RDA is activated when the UART1 Rx FIFO reaches the trigger level defined in FCR7:6 and is reset when the UART1 Rx FIFO depth falls below the trigger level. When the RDA interrupt goes active, the CPU can read a block of data defined by the trigger level.

The CTI interrupt (IIR[3:1] = 110) is a second level interrupt and is set when the UART1 Rx FIFO contains at least one character and no UART1 Rx FIFO activity has occurred in 3.5 to 4.5 character times. Any UART1 Rx FIFO activity (read or write of UART1 RSR) will clear the interrupt. This interrupt is intended to flush the UART1 RBR after a message has been received that is not a multiple of the trigger level size. For example, if a peripheral wished to send a 105 character message and the trigger level was 10 characters, the CPU would receive 10 RDA interrupts resulting in the transfer of 100 characters and 1 to 5 CTI interrupts (depending on the service routine) resulting in the transfer of the remaining 5 characters.

Table 879: UART1 Interrupt Handling

IIR[3:0] value ^[1]	Priority	Interrupt Type	Interrupt Source	Interrupt Reset
0001	-	None	None	-
0110	Highest	RX Line Status / Error	OE ^[2] or PE ^[2] or FE ^[2] or BI ^[2]	LSR Read ^[2]
0100	Second	RX Data Available	Rx data available or trigger level reached in FIFO (FCR0=1)	RBR Read ^[3] or UART1 FIFO drops below trigger level

Table 879: UART1 Interrupt Handling

IIR[3:0] value ^[1]	Priority	Interrupt Type	Interrupt Source	Interrupt Reset
1100	Second	Character Time-out indication	Minimum of one character in the RX FIFO and no character input or removed during a time period depending on how many characters are in FIFO and what the trigger level is set at (3.5 to 4.5 character times). The exact time will be: [(word length) × 7 - 2] × 8 + [(trigger level - number of characters) × 8 + 1] RCLKs	RBR Read ^[3]
0010	Third	THRE	THRE ^[2]	IIR Read ^[4] (if source of interrupt) or THR write
0000	Fourth	Modem Status	CTS or DSR or RI or DCD	MSR Read

[1] Values "0000", "0011", "0101", "0111", "1000", "1001", "1010", "1011", "1101", "1110", "1111" are reserved.

[2] For details see [Section 39.6.9 "UART1 Line Status Register"](#)

[3] For details see [Section 39.6.1 "UART1 Receiver Buffer Register \(when DLAB = 0\)"](#)

[4] For details see [Section 39.6.5 "UART1 Interrupt Identification Register"](#) and [Section 39.6.2 "UART1 Transmitter Holding Register \(when DLAB = 0\)"](#)

The UART1 THRE interrupt (IIR[3:1] = 001) is a third level interrupt and is activated when the UART1 THR FIFO is empty provided certain initialization conditions have been met. These initialization conditions are intended to give the UART1 THR FIFO a chance to fill up with data to eliminate many THRE interrupts from occurring at system start-up. The initialization conditions implement a one character delay minus the stop bit whenever THRE = 1 and there have not been at least two characters in the THR at one time since the last THRE = 1 event. This delay is provided to give the CPU time to write data to THR without a THRE interrupt to decode and service. A THRE interrupt is set immediately if the UART1 THR FIFO has held two or more characters at one time and currently, the THR is empty. The THRE interrupt is reset when a THR write occurs or a read of the IIR occurs and the THRE is the highest interrupt (IIR[3:1] = 001).

It is the lowest priority interrupt and is activated whenever there is any state change on modem inputs pins, DCD, DSR or CTS. In addition, a low to high transition on modem input RI will generate a modem interrupt. The source of the modem interrupt can be determined by examining MSR[3:0]. A MSR read will clear the modem interrupt.

39.6.6 UART1 FIFO Control Register

The write-only FCR controls the operation of the UART1 RX and TX FIFOs.

Table 880: UART1 FIFO Control Register (FCR - address 0x4008 2008) bit description

Bit	Symbol	Value	Description	Reset value
0	FIFOEN		FIFO enable.	0
		0	Must not be used in the application.	
		1	Active high enable for both UART1 Rx and TX FIFOs and FCR[7:1] access. This bit must be set for proper UART1 operation. Any transition on this bit will automatically clear the UART1 FIFOs.	

Table 880: UART1 FIFO Control Register (FCR - address 0x4008 2008) bit description

Bit	Symbol	Value	Description	Reset value
1	RXFIFORES		RX FIFO Reset.	0
		0	No impact on either of UART1 FIFOs.	
		1	Writing a logic 1 to FCR[1] will clear all bytes in UART1 Rx FIFO, reset the pointer logic. This bit is self-clearing.	
2	TXFIFORES		TX FIFO Reset.	0
		0	No impact on either of UART1 FIFOs.	
		1	Writing a logic 1 to FCR[2] will clear all bytes in UART1 TX FIFO, reset the pointer logic. This bit is self-clearing.	
3	DMAMODE		DMA Mode Select. When the FIFO enable bit (bit 0 of this register) is set, this bit selects the DMA mode. See Section 39.6.6.1 .	0
5:4	-		Reserved, user software should not write ones to reserved bits. The value read from a reserved bit is not defined.	NA
7:6	RXTRIGLVL		RX Trigger Level. These two bits determine how many receiver UART1 FIFO characters must be written before an interrupt is activated.	0
		0x0	Trigger level 0 (1 character or 0x01).	
		0x1	Trigger level 1 (4 characters or 0x04).	
		0x2	Trigger level 2 (8 characters or 0x08).	
		0x3	Trigger level 3 (14 characters or 0x0E).	
31:8	-		Reserved, user software should not write ones to reserved bits.	NA

39.6.6.1 DMA Operation

The user can optionally operate the UART transmit and/or receive using DMA. The DMA mode is determined by the DMA Mode Select bit in the FCR register. Note that for DMA operation as for any operation of the UART, the FIFOs must be enabled via the FIFO Enable bit in the FCR register.

UART receiver DMA

In DMA mode, the receiver DMA request is asserted on the event of the receiver FIFO level becoming equal to or greater than trigger level, or if a character time-out occurs. See the description of the RX Trigger Level above. The receiver DMA request is cleared by the DMA controller.

UART transmitter DMA

In DMA mode, the transmitter DMA request is asserted on the event of the transmitter FIFO transitioning to not full. The transmitter DMA request is cleared by the DMA controller.

39.6.7 UART1 Line Control Register

The LCR determines the format of the data character that is to be transmitted or received.

Table 881: UART1 Line Control Register (LCR - address 0x4008 200C) bit description

Bit	Symbol	Value	Description	Reset value
1:0	WLS		Word Length Select.	0
		0x0	5-bit character length.	
		0x1	6-bit character length.	
		0x2	7-bit character length.	
		0x3	8-bit character length.	
2	SBS		Stop Bit Select.	0
		0	1 stop bit.	
		1	2 stop bits (1.5 if LCR[1:0]=00).	
3	PE		Parity Enable.	0
		0	Disable parity generation and checking.	
		1	Enable parity generation and checking.	
5:4	PS		Parity Select.	0
		0x0	Odd parity. Number of 1s in the transmitted character and the attached parity bit will be odd.	
		0x1	Even Parity. Number of 1s in the transmitted character and the attached parity bit will be even.	
		0x2	Forced "1" stick parity.	
		0x3	Forced "0" stick parity.	
6	BC		Break Control.	0
		0	Disable break transmission.	
		1	Enable break transmission. Output pin UART1 TXD is forced to logic 0 when LCR[6] is active high.	
7	DLAB		Divisor Latch Access Bit (DLAB)	0
		0	Disable access to Divisor Latches.	
		1	Enable access to Divisor Latches.	
31:8	-		Reserved, user software should not write ones to reserved bits. The value read from a reserved bit is not defined.	NA

39.6.8 UART1 Modem Control Register

The MCR enables the modem loopback mode and controls the modem output signals.

Table 882: UART1 Modem Control Register (MCR - address 0x4008 2010) bit description

Bit	Symbol	Value	Description	Reset value
0	DTRCTRL	-	DTR Control. Source for modem output pin, DTR. This bit reads as 0 when modem loopback mode is active.	0
1	RTSCTRL	-	RTS Control. Source for modem output pin RTS. This bit reads as 0 when modem loopback mode is active.	0
3:2	-		Reserved, user software should not write ones to reserved bits. The value read from a reserved bit is not defined.	0

Table 882: UART1 Modem Control Register (MCR - address 0x4008 2010) bit description

Bit	Symbol	Value	Description	Reset value
4	LMS		Loopback Mode Select. The modem loopback mode provides a mechanism to perform diagnostic loopback testing. Serial data from the transmitter is connected internally to serial input of the receiver. Input pin, RXD1, has no effect on loopback and output pin, TXD1 is held in marking state. The 4 modem inputs (CTS, DSR, RI and DCD) are disconnected externally. Externally, the modem outputs (RTS, DTR) are set inactive. Internally, the 4 modem outputs are connected to the 4 modem inputs. As a result of these connections, the upper 4 bits of the MSR will be driven by the lower 4 bits of the MCR rather than the 4 modem inputs in normal mode. This permits modem status interrupts to be generated in loopback mode by writing the lower 4 bits of MCR.	0
		0	Disable modem loopback mode.	
		1	Enable modem loopback mode.	
5	-		Reserved, user software should not write ones to reserved bits. The value read from a reserved bit is not defined.	0
6	RTSEN		RTS enable.	0
		0	Disable auto-rts flow control.	
		1	Enable auto-rts flow control.	
7	CTSEN		CTS enable.	0
		0	Disable auto-cts flow control.	
		1	Enable auto-cts flow control.	
31:8	-		Reserved, user software should not write ones to reserved bits. The value read from a reserved bit is not defined.	NA

39.6.9 UART1 Line Status Register

The LSR is a read-only register that provides status information on the UART1 TX and RX blocks.

Table 883: UART1 Line Status Register (LSR - address 0x4008 2014) bit description

Bit	Symbol	Value	Description	Reset value
0	RDR		Receiver Data Ready. LSR[0] is set when the RBR holds an unread character and is cleared when the UART1 RBR FIFO is empty.	0
		0	The UART1 receiver FIFO is empty.	
		1	The UART1 receiver FIFO is not empty.	
1	OE		Overrun Error. The overrun error condition is set as soon as it occurs. An LSR read clears LSR[1]. LSR[1] is set when UART1 RSR has a new character assembled and the UART1 RBR FIFO is full. In this case, the UART1 RBR FIFO will not be overwritten and the character in the UART1 RSR will be lost.	0
		0	Overrun error status is inactive.	
		1	Overrun error status is active.	

Table 883: UART1 Line Status Register (LSR - address 0x4008 2014) bit description

Bit	Symbol	Value	Description	Reset value
2	PE		Parity Error. When the parity bit of a received character is in the wrong state, a parity error occurs. An LSR read clears LSR[2]. Time of parity error detection is dependent on FCR[0]. Note: A parity error is associated with the character at the top of the UART1 RBR FIFO.	0
		0	Parity error status is inactive.	
		1	Parity error status is active.	
3	FE		Framing Error. When the stop bit of a received character is a logic 0, a framing error occurs. An LSR read clears LSR[3]. The time of the framing error detection is dependent on FCR0. Upon detection of a framing error, the RX will attempt to resynchronize to the data and assume that the bad stop bit is actually an early start bit. However, it cannot be assumed that the next received byte will be correct even if there is no Framing Error. Note: A framing error is associated with the character at the top of the UART1 RBR FIFO.	0
		0	Framing error status is inactive.	
		1	Framing error status is active.	
4	BI		Break Interrupt. When RXD1 is held in the spacing state (all zeroes) for one full character transmission (start, data, parity, stop), a break interrupt occurs. Once the break condition has been detected, the receiver goes idle until RXD1 goes to marking state (all ones). An LSR read clears this status bit. The time of break detection is dependent on FCR[0]. Note: The break interrupt is associated with the character at the top of the UART1 RBR FIFO.	0
		0	Break interrupt status is inactive.	
		1	Break interrupt status is active.	
5	THRE		Transmitter Holding Register Empty. THRE is set immediately upon detection of an empty UART1 THR and is cleared on a THR write.	1
		0	THR contains valid data.	
		1	THR is empty.	
6	TEMT		Transmitter Empty. TEMT is set when both THR and TSR are empty; TEMT is cleared when either the TSR or the THR contain valid data.	1
		0	THR and/or the TSR contains valid data.	
		1	THR and the TSR are empty.	
7	RXFE		Error in RX FIFO. LSR[7] is set when a character with a RX error such as framing error, parity error or break interrupt, is loaded into the RBR. This bit is cleared when the LSR register is read and there are no subsequent errors in the UART1 FIFO.	0
		0	RBR contains no UART1 RX errors or FCR[0]=0.	
		1	UART1 RBR contains at least one UART1 RX error.	
31:8	-		Reserved, the value read from a reserved bit is not defined.	NA

39.6.10 UART1 Modem Status Register

The MSR is a read-only register that provides status information on the modem input signals. MSR[3:0] is cleared on U1MSR read. Note that modem signals have no direct effect on UART1 operation, they facilitate software implementation of modem signal operations.

Table 884: UART1 Modem Status Register (MSR - address 0x4008 2018) bit description

Bit	Symbol	Value	Description	Reset value
0	DCTS		Delta CTS. Set upon state change of input CTS. Cleared on an MSR read.	0
		0	No change detected on modem input, CTS.	
		1	State change detected on modem input, CTS.	
1	DDSR		Delta DSR. Set upon state change of input DSR. Cleared on an MSR read.	0
		0	No change detected on modem input, DSR.	
		1	State change detected on modem input, DSR.	
2	TERI		Trailing Edge RI. Set upon low to high transition of input RI. Cleared on an MSR read.	0
		0	No change detected on modem input, RI.	
		1	Low-to-high transition detected on RI.	
3	DDCD		Delta DCD. Set upon state change of input DCD. Cleared on an MSR read.	0
		0	No change detected on modem input, DCD.	
		1	State change detected on modem input, DCD.	
4	CTS	-	Clear To Send State. Complement of input signal CTS. This bit is connected to MCR[1] in modem loopback mode.	0
5	DSR	-	Data Set Ready State. Complement of input signal DSR. This bit is connected to MCR[0] in modem loopback mode.	0
6	RI	-	Ring Indicator State. Complement of input RI. This bit is connected to MCR[2] in modem loopback mode.	0
7	DCD	-	Data Carrier Detect State. Complement of input DCD. This bit is connected to MCR[3] in modem loopback mode.	0
31:8	-	-	Reserved, the value read from a reserved bit is not defined.	NA

39.6.11 UART1 Scratch Pad Register

The SCR has no effect on the UART1 operation. This register can be written and/or read at user's discretion. There is no provision in the interrupt interface that would indicate to the host that a read or write of the SCR has occurred.

Table 885: UART1 Scratch Pad Register (SCR - address 0x4008 2014) bit description

Bit	Symbol	Description	Reset value
7:0	Pad	Scratch pad. A readable, writable byte.	0x00
31:8	-	Reserved, the value read from a reserved bit is not defined.	NA

39.6.12 UART1 Auto-baud Control Register

The UART1 Auto-baud Control Register (ACR) controls the process of measuring the incoming clock/data rate for the baud rate generation and can be read and written at user's discretion.

Table 886: Autobaud Control Register (ACR - address 0x4008 2020) bit description

Bit	Symbol	Value	Description	Reset value
0	START		Auto-baud start bit. This bit is automatically cleared after auto-baud completion.	0
		0	Auto-baud stop (auto-baud is not running).	
		1	Auto-baud start (auto-baud is running). Auto-baud run bit. This bit is automatically cleared after auto-baud completion.	
1	MODE		Auto-baud mode select bit.	0
		0	Mode 0.	
		1	Mode 1.	
2	AUTORESTART		Auto-baud restart bit.	0
		0	No restart	
		1	Restart in case of time-out (counter restarts at next UART1 Rx falling edge)	
7:3	-	-	Reserved, user software should not write ones to reserved bits. The value read from a reserved bit is not defined.	0
8	ABEOINTCLR		End of auto-baud interrupt clear bit (write-only).	0
		0	Writing a 0 has no impact.	
		1	Writing a 1 will clear the corresponding interrupt in the IIR.	
9	ABTOINTCLR		Auto-baud time-out interrupt clear bit (write-only).	0
		0	Writing a 0 has no impact.	
		1	Writing a 1 will clear the corresponding interrupt in the IIR.	
31:10	-	-	Reserved, user software should not write ones to reserved bits. The value read from a reserved bit is not defined.	0

39.6.13 UART1 Fractional Divider Register

The UART1 Fractional Divider Register (FDR) controls the clock pre-scaler for the baud rate generation and can be read and written at the user's discretion. This pre-scaler takes the APB clock and generates an output clock according to the specified fractional requirements.

Important: If the fractional divider is active ($DIVADDVAL > 0$) and $DLM = 0$, the value of the DLL register must be greater than 2.

Table 887: UART1 Fractional Divider Register (FDR - address 0x4008 2028) bit description

Bit	Function	Description	Reset value
3:0	DIVADDVAL	Baud-rate generation pre-scaler divisor value. If this field is 0, fractional baud-rate generator will not impact the UARTn baudrate.	0
7:4	MULVAL	Baud-rate pre-scaler multiplier value. This field must be greater or equal 1 for UARTn to operate properly, regardless of whether the fractional baud-rate generator is used or not.	1
31:8	-	Reserved, user software should not write ones to reserved bits. The value read from a reserved bit is not defined.	0

This register controls the clock pre-scaler for the baud rate generation. The reset value of the register keeps the fractional capabilities of UART1 disabled making sure that UART1 is fully software and hardware compatible with UARTs not equipped with this feature.

UART1 baud rate can be calculated as ($n = 1$):

(10)

$$UART1_{baudrate} = \frac{PCLK}{16 \times (256 \times DLM + DLL) \times \left(1 + \frac{DivAddVal}{MulVal}\right)}$$

Where PCLK is the peripheral clock, DLM and DLL are the standard UART1 baud rate divider registers, and DIVADDVAL and MULVAL are UART1 fractional baud rate generator specific parameters.

The value of MULVAL and DIVADDVAL should comply to the following conditions:

1. $1 \leq MULVAL \leq 15$
2. $0 \leq DIVADDVAL \leq 14$
3. $DIVADDVAL < MULVAL$

The value of the FDR should not be modified while transmitting/receiving data or data may be lost or corrupted.

If the FDR register value does not comply to these two requests, then the fractional divider output is undefined. If DIVADDVAL is zero then the fractional divider is disabled, and the clock will not be divided.

39.6.14 UART1 RS485 Control register

The RS485CTRL register controls the configuration of the UART in RS-485/EIA-485 mode.

Table 888: UART1 RS485 Control register (RS485CTRL - address 0x4008 204C) bit description

Bit	Symbol	Value	Description	Reset value
0	NMMEN		Multidrop mode select.	0
		0	RS-485/EIA-485 Normal Multidrop Mode (NMM) is disabled.	
		1	RS-485/EIA-485 Normal Multidrop Mode (NMM) is enabled. In this mode, an address is detected when a received byte causes the UART to set the parity error and generate an interrupt.	
1	RXDIS		Receive enable.	0
		0	The receiver is enabled.	
		1	The receiver is disabled.	
2	AADEN		Auto Address Detect enable.	0
		0	Auto Address Detect (AAD) is disabled.	
		1	Auto Address Detect (AAD) is enabled.	
3	SEL		Direction control.	0
		0	If direction control is enabled (bit DCTRL = 1), pin \overline{RTS} is used for direction control.	
		1	If direction control is enabled (bit DCTRL = 1), pin DTR is used for direction control.	
4	DCTRL		Direction control enable.	0
		0	Disable Auto Direction Control.	
		1	Enable Auto Direction Control.	

Table 888: UART1 RS485 Control register (RS485CTRL - address 0x4008 204C) bit description

Bit	Symbol	Value	Description	Reset value
5	OINV		Polarity. This bit reverses the polarity of the direction control signal on the RTS (or DTR) pin.	0
		0	The direction control pin will be driven to logic '0' when the transmitter has data to be sent. It will be driven to logic '1' after the last bit of data has been transmitted.	
		1	The direction control pin will be driven to logic '1' when the transmitter has data to be sent. It will be driven to logic '0' after the last bit of data has been transmitted.	
31:6	-	-	Reserved, user software should not write ones to reserved bits. The value read from a reserved bit is not defined.	NA

39.6.15 UART1 RS-485 Address Match register

The RS485ADRMATCH register contains the address match value for RS-485/EIA-485 mode.

Table 889. UART1 RS485 Address Match register (RS485ADRMATCH - address 0x4008 2050) bit description

Bit	Symbol	Description	Reset value
7:0	ADRMATCH	Contains the address match value.	0x00
31:8	-	Reserved, user software should not write ones to reserved bits. The value read from a reserved bit is not defined.	NA

39.6.16 UART1 RS-485 Delay value register

The user may program the 8-bit RS485DLY register with a delay between the last stop bit leaving the TXFIFO and the de-assertion of RTS (or DTR). This delay time is in periods of the baud clock. Any delay time from 0 to 255 bit times may be programmed.

Table 890. UART1 RS485 Delay value register (RS485DLY - address 0x4008 2054) bit description

Bit	Symbol	Description	Reset value
7:0	DLY	Contains the direction control (RTS or DTR) delay value. This register works in conjunction with an 8-bit counter.	0x00
31:8	-	Reserved, user software should not write ones to reserved bits. The value read from a reserved bit is not defined.	NA

39.6.17 UART1 Transmit Enable Register

In addition to being equipped with full hardware flow control (auto-cts and auto-rts mechanisms described above), TER enables implementation of software flow control, too. When TXEN=1, UART1 transmitter will keep sending data as long as they are available. As soon as TXEN becomes 0, UART1 transmission will stop.

Table 891: UART1 Transmit Enable Register (TER - address 0x4008 205C) bit description

Bit	Symbol	Description	Reset value
0	TXEN	Transmit enable. After reset transmission is enabled. When the TXEN bit is de-asserted, no data will be transmitted although data may be pending in the TSR or THR.	1
31:1	-	Reserved, user software should not write ones to reserved bits. The value read from a reserved bit is not defined.	-

39.7 Functional description

39.7.1 Auto-flow control

If auto-RTS mode is enabled the UART1's receiver FIFO hardware controls the RTS1 output of the UART1. If the auto-CTS mode is enabled the UART1's TSR hardware will only start transmitting if the CTS1 input signal is asserted.

39.7.1.1 Auto-RTS

The auto-RTS function is enabled by setting the RTSen bit. Auto-RTS data flow control originates in the RBR module and is linked to the programmed receiver FIFO trigger level. If auto-RTS is enabled, the data-flow is controlled as follows:

When the receiver FIFO level reaches the programmed trigger level, RTS1 is de-asserted (to a high value). It is possible that the sending UART sends an additional byte after the trigger level is reached (assuming the sending UART has another byte to send) because it might not recognize the de-assertion of RTS1 until after it has begun sending the additional byte. RTS1 is automatically reasserted (to a low value) once the receiver FIFO has reached the previous trigger level. The re-assertion of RTS1 signals to the sending UART to continue transmitting data.

If Auto-RTS mode is disabled, the RTSen bit controls the RTS1 output of the UART1. If Auto-RTS mode is enabled, hardware controls the RTS1 output, and the actual value of RTS1 will be copied in the RTS Control bit of the UART1. As long as Auto-RTS is enabled, the value of the RTS Control bit is read-only for software.

Example: Suppose the UART1 operating in '550 mode has trigger level in FCR set to 0x2 then if Auto-RTS is enabled the UART1 will de-assert the RTS1 output as soon as the receive FIFO contains 8 bytes ([Table 880 on page 1056](#)). The RTS1 output will be reasserted as soon as the receive FIFO hits the previous trigger level: 4 bytes.

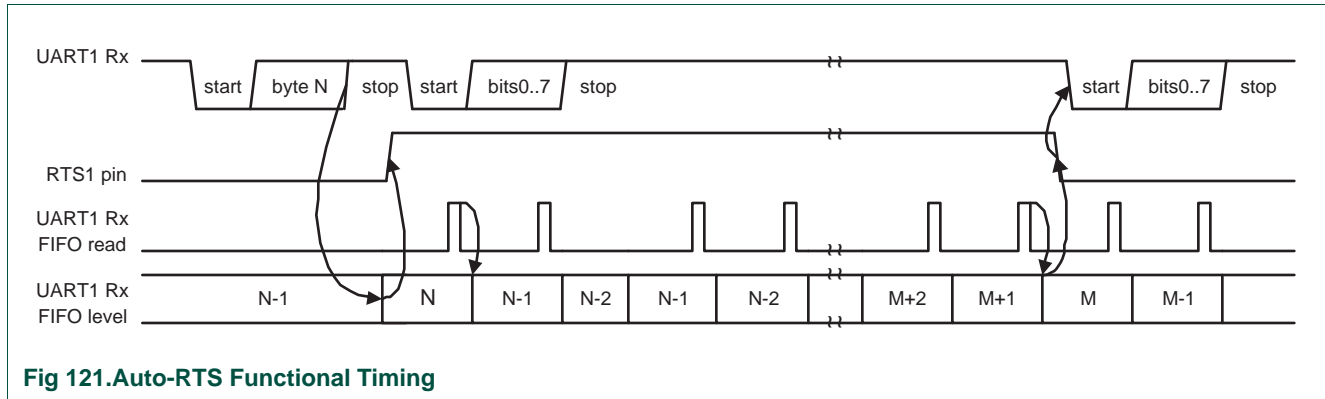

Fig 121.Auto-RTS Functional Timing

39.7.1.2 Auto-CTS

The Auto-CTS function is enabled by setting the CTSen bit. If Auto-CTS is enabled the transmitter circuitry in the TSR module checks CTS1 input before sending the next data byte. When CTS1 is active (low), the transmitter sends the next byte. To stop the transmitter from sending the following byte, CTS1 must be released before the middle of the last stop bit that is currently being sent. In Auto-CTS mode a change of the CTS1 signal does not trigger a modem status interrupt unless the CTS Interrupt Enable bit is set, Delta CTS bit in the MSR will be set though. [Table 892](#) lists the conditions for generating a Modem Status interrupt.

Table 892: Modem status interrupt generation

Enable Modem Status Interrupt (ER[3])	CTS _{en} (MCR[7])	CTS Interrupt Enable (IER[7])	Delta CTS (MSR[0])	Delta DCD or Trailing Edge RI or Delta DSR (MSR[3] or MSR[2] or MSR[1])	Modem Status Interrupt
0	x	x	x	x	No
1	0	x	0	0	No
1	0	x	1	x	Yes
1	0	x	x	1	Yes
1	1	0	x	0	No
1	1	0	x	1	Yes
1	1	1	0	0	No
1	1	1	1	x	Yes
1	1	1	x	1	Yes

The auto-CTS function reduces interrupts to the host system. When flow control is enabled, a CTS1 state change does not trigger host interrupts because the device automatically controls its own transmitter. Without Auto-CTS, the transmitter sends any data present in the transmit FIFO and a receiver overrun error can result. [Figure 122](#) illustrates the Auto-CTS functional timing.

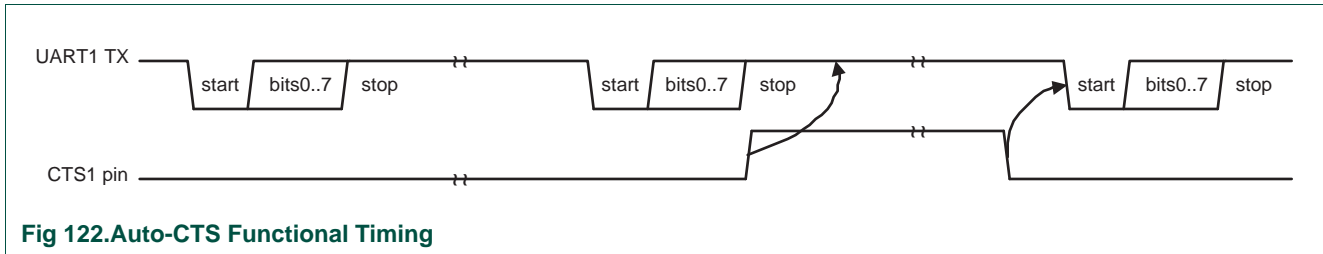

Fig 122. Auto-CTS Functional Timing

While starting transmission of the initial character the CTS1 signal is asserted. Transmission will stall as soon as the pending transmission has completed. The UART will continue transmitting a 1 bit as long as CTS1 is de-asserted (high). As soon as CTS1 gets de-asserted transmission resumes and a start bit is sent followed by the data bits of the next character.

39.7.2 Auto-baud

See [Section 38.7.1](#).

39.7.3 Auto-baud modes

See [Section 38.7.2](#).

39.7.4 Baud rate calculation

See [Section 38.7.3](#).

39.7.5 RS-485/EIA-485 modes of operation

See [Section 38.7.4](#).

40.1 How to read this chapter

The SSP0/1 controllers are available on all LPC18xx parts.

40.2 Basic configuration

The SSP0/1 are configured as follows:

- See [Table 893](#) for clocking and power control.
- The SSP0/1 are reset by the SSP0/1_RST (reset #50/51).
- The SSP0/1 interrupts are connected to slots # 22/23 in the NVIC.
- For connecting the SSP0/1 receive and transmit lines to the GPDMA, use the DMAMUX register in the CREG block (see [Table 92](#)).

Table 893. SSP0/1 clocking and power control

	Base clock	Branch clock	Operating frequency
Clock to SSP0 register interface	BASE_M3_CLK	CLK_M3_SSP0	up to 180 MHz
SSP0 peripheral clock (PCLK)	BASE_SSP0_CLK	CLK_APB0_SSP0	up to 180 MHz
Clock to SSP1 register interface	BASE_M3_CLK	CLK_M3_SSP1	up to 180 MHz
SSP1 peripheral clock (PCLK)	BASE_SSP1_CLK	CLK_APB2_SSP1	up to 180 MHz

40.3 Features

- Compatible with Motorola SPI, 4-wire TI SSI, and National Semiconductor Microwire buses.
- Synchronous Serial Communication.
- Supports master or slave operation.
- Eight-frame FIFOs for both transmit and receive.
- 4-bit to 16-bit frame.

40.4 General description

The SSP is a Synchronous Serial Port (SSP) controller capable of operation on a SPI, 4-wire SSI, or Microwire bus. It can interact with multiple masters and slaves on the bus. Only a single master and a single slave can communicate on the bus during a given data transfer. Data transfers are in principle full duplex, with frames of 4 to 16 bits of data flowing from the master to the slave and from the slave to the master. In practice it is often the case that only one of these data flows carries meaningful data.

The LPC18xx has two Synchronous Serial Port controllers -- SSP0 and SSP1.

40.5 Pin description

Table 894. SSP pin description

Pin function	Direction	Interface pin name/function			Pin description
		SPI	SSI	Microwire	
SSP0/1_ SCK	I/O	SCK	CLK	SK	Serial Clock. SCK/CLK/SK is a clock signal used to synchronize the transfer of data. It is driven by the master and received by the slave. When the SPI interface is used, the clock is programmable to be active-high or active-low, otherwise it is always active-high. SCK1 only switches during a data transfer. Any other time, the SSPn interface either holds it in its inactive state, or does not drive it (leaves it in high-impedance state).
SSP0/1_ SSEL	I/O	SSEL	FS	CS	Frame Sync/Slave Select. When the SSPn interface is a bus master, it drives this signal to an active state before the start of serial data, and then releases it to an inactive state after the serial data has been sent. The active state of this signal can be high or low depending upon the selected bus and mode. When the SSPn is a bus slave, this signal qualifies the presence of data from the Master, according to the protocol in use. When there is just one bus master and one bus slave, the Frame Sync or Slave Select signal from the Master can be connected directly to the slave's corresponding input. When there is more than one slave on the bus, further qualification of their Frame Select/Slave Select inputs will typically be necessary to prevent more than one slave from responding to a transfer.
SSP0/1_ MISO	I/O	MISO	DR(M) DX(S)	SI(M) SO(S)	Master In Slave Out. The MISO signal transfers serial data from the slave to the master. When the SSPn is a slave, serial data is output on this signal. When the SSPn is a master, it clocks in serial data from this signal. When the SSPn is a slave and is not selected by FS/SSEL, it does not drive this signal (leaves it in high-impedance state).
SSP0/1_ MOSI	I/O	MOSI	DX(M) DR(S)	SO(M) SI(S)	Master Out Slave In. The MOSI signal transfers serial data from the master to the slave. When the SSPn is a master, it outputs serial data on this signal. When the SSPn is a slave, it clocks in serial data from this signal.

40.6 Register description

The register addresses of the SSP controllers are shown in [Table 895](#) and [Table 896](#).

Table 895. Register overview: SSP0 (base address 0x4008 3000)

Name	Access	Address offset	Description	Reset value ^[1]	Reference
CR0	R/W	0x000	Control Register 0. Selects the serial clock rate, bus type, and data size.	0	Table 897
CR1	R/W	0x004	Control Register 1. Selects master/slave and other modes.	0	Table 898
DR	R/W	0x008	Data Register. Writes fill the transmit FIFO, and reads empty the receive FIFO.	0	Table 899
SR	RO	0x00C	Status Register	0x0000 0003	Table 900
CPSR	R/W	0x010	Clock Prescale Register	0	Table 901

Table 895. Register overview: SSP0 (base address 0x4008 3000)

Name	Access	Address offset	Description	Reset value ^[1]	Reference
IMSC	R/W	0x014	Interrupt Mask Set and Clear Register	0	Table 902
RIS	RO	0x018	Raw Interrupt Status Register	0x0000 0008	Table 903
MIS	RO	0x01C	Masked Interrupt Status Register	0	Table 904
ICR	WO	0x020	SSPICR Interrupt Clear Register	-	Table 905
DMACR	R/W	0x024	SSP0 DMA control register	0	Table 906

[1] Reset value reflects the data stored in used bits only. It does not include reserved bits content.

Table 896. Register overview: SSP1 (base address 0x400C 5000)

Name	Access	Address offset	Description	Reset value ^[1]	Reference
CR0	R/W	0x000	Control Register 0. Selects the serial clock rate, bus type, and data size.	0	Table 897
CR1	R/W	0x004	Control Register 1. Selects master/slave and other modes.	0	Table 898
DR	R/W	0x008	Data Register. Writes fill the transmit FIFO, and reads empty the receive FIFO.	0	Table 899
SR	RO	0x00C	Status Register	0x0000 0003	Table 900
CPSR	R/W	0x010	Clock Prescale Register	0	Table 901
IMSC	R/W	0x014	Interrupt Mask Set and Clear Register	0	Table 902
RIS	RO	0x018	Raw Interrupt Status Register	0x0000 0008	Table 903
MIS	RO	0x01C	Masked Interrupt Status Register	0	Table 904
ICR	R/W	0x020	SSPICR Interrupt Clear Register	-	Table 905
DMACR	R/W	0x024	SSP1 DMA control register	0	Table 906

[1] Reset value reflects the data stored in used bits only. It does not include reserved bits content.

40.6.1 SSP Control Register 0

This register controls the basic operation of the SSP controller.

Table 897: SSP Control Register 0 (CR0 - address 0x4008 3000 (SSP0), 0x400C 5000 (SSP1)) bit description

Bit	Symbol	Value	Description	Reset value
3:0	DSS		Data Size Select. This field controls the number of bits transferred in each frame. Values 0000-0010 are not supported and should not be used.	0000
		0x3	4-bit transfer	
		0x4	5-bit transfer	
		0x5	6-bit transfer	
		0x6	7-bit transfer	
		0x7	8-bit transfer	
		0x8	9-bit transfer	
		0x9	10-bit transfer	
		0xA	11-bit transfer	
		0xB	12-bit transfer	
		0xC	13-bit transfer	
		0xD	14-bit transfer	
		0xE	15-bit transfer	
		0xF	16-bit transfer	
5:4	FRF		Frame Format.	00
		0x0	SPI	
		0x1	TI	
		0x2	Microwire	
		0x3	This combination is not supported and should not be used.	
6	CPOL		Clock Out Polarity. This bit is only used in SPI mode.	0
		0	SSP controller maintains the bus clock low between frames.	
		1	SSP controller maintains the bus clock high between frames.	
7	CPHA		Clock Out Phase. This bit is only used in SPI mode.	0
		0	SSP controller captures serial data on the first clock transition of the frame, that is, the transition away from the inter-frame state of the clock line.	
		1	SSP controller captures serial data on the second clock transition of the frame, that is, the transition back to the inter-frame state of the clock line.	
15:8	SCR		Serial Clock Rate. The number of prescaler-output clocks per bit on the bus, minus one. Given that CPSDVSR is the prescale divider, and the APB clock PCLK clocks the prescaler, the bit frequency is $PCLK / (CPSDVSR \times [SCR+1])$.	0x00
31:16	-		Reserved, user software should not write ones to reserved bits. The value read from a reserved bit is not defined.	NA

40.6.2 SSP Control Register 1

This register controls certain aspects of the operation of the SSP controller.

Table 898: SSP Control Register 1 (CR1 - address 0x4008 3004 (SSP0), 0x400C 5004 (SSP1)) bit description

Bit	Symbol	Value	Description	Reset value
0	LBM		Loop Back Mode.	0
		0	Normal operation.	
		1	Loop back mode. Serial input is taken from the serial output (MOSI or MISO) rather than the serial input pin (MISO or MOSI respectively).	
1	SSE		SSP Enable.	0
		0	The SSP controller is disabled.	
		1	The SSP controller will interact with other devices on the serial bus. Software should write the appropriate control information to the other SSP registers and interrupt controller registers, before setting this bit.	
2	MS		Master/Slave Mode. This bit can only be written when the SSE bit is 0.	0
		0	The SSP controller acts as a master on the bus, driving the SCLK, MOSI, and SSEL lines and receiving the MISO line.	
		1	The SSP controller acts as a slave on the bus, driving MISO line and receiving SCLK, MOSI, and SSEL lines.	
3	SOD		Slave Output Disable. This bit is relevant only in slave mode (MS = 1). If it is 1, this blocks this SSP controller from driving the transmit data line (MISO).	0
31:4	-		Reserved, user software should not write ones to reserved bits. The value read from a reserved bit is not defined.	NA

40.6.3 SSP Data Register

Software can write data to be transmitted to this register, and read data that has been received.

Table 899: SSP Data Register (DR - address 0x4008 3008 (SSP0), 0x400C 5008 (SSP1)) bit description

Bit	Symbol	Description	Reset value
15:0	DATA	<p>Write: software can write data to be sent in a future frame to this register whenever the TNF bit in the Status register is 1, indicating that the Tx FIFO is not full. If the Tx FIFO was previously empty and the SSP controller is not busy on the bus, transmission of the data will begin immediately. Otherwise the data written to this register will be sent as soon as all previous data has been sent (and received). If the data length is less than 16 bits, software must right-justify the data written to this register.</p> <p>Read: software can read data from this register whenever the RNE bit in the Status register is 1, indicating that the Rx FIFO is not empty. When software reads this register, the SSP controller returns data from the least recent frame in the Rx FIFO. If the data length is less than 16 bits, the data is right-justified in this field with higher order bits filled with 0s.</p>	0x0000
31:16	-	Reserved, user software should not write ones to reserved bits. The value read from a reserved bit is not defined.	NA

40.6.4 SSP Status Register

This read-only register reflects the current status of the SSP controller.

Table 900: SSP Status Register (SR - address 0x4008 300C (SSP0), 0x400C 500C (SSP1)) bit description

Bit	Symbol	Description	Reset value
0	TFE	Transmit FIFO Empty. This bit is 1 if the Transmit FIFO is empty, 0 if not.	1
1	TNF	Transmit FIFO Not Full. This bit is 0 if the Tx FIFO is full, 1 if not.	1
2	RNE	Receive FIFO Not Empty. This bit is 0 if the Receive FIFO is empty, 1 if not.	0
3	RFF	Receive FIFO Full. This bit is 1 if the Receive FIFO is full, 0 if not.	0
4	BSY	Busy. This bit is 0 if the SSPn controller is idle, or 1 if it is currently sending/receiving a frame and/or the Tx FIFO is not empty.	0
31:5	-	Reserved, user software should not write ones to reserved bits. The value read from a reserved bit is not defined.	NA

40.6.5 SSP Clock Prescale Register

This register controls the factor by which the Prescaler divides the SSP peripheral clock PCLK to yield the prescaler clock that is, in turn, divided by the SCR factor in SSPnCR0, to determine the bit clock.

Table 901: SSP Clock Prescale Register (CPSR - address 0x4008 3010 (SSP0), 0x400C 5010 (SSP1)) bit description

Bit	Symbol	Description	Reset value
7:0	CPSDVSR	This even value between 2 and 254, by which PCLK is divided to yield the prescaler output clock. Bit 0 always reads as 0.	0
31:8	-	Reserved, user software should not write ones to reserved bits. The value read from a reserved bit is not defined.	NA

Important: the SSPnCPSR value must be properly initialized or the SSP controller will not be able to transmit data correctly.

In Slave mode, the SSP clock rate provided by the master must not exceed 1/12 of the SSP peripheral clock. The content of the SSPnCPSR register is not relevant.

In master mode, $CPSDVSR_{min} = 2$ or larger (even numbers only).

40.6.6 SSP Interrupt Mask Set/Clear Register

This register controls whether each of the four possible interrupt conditions in the SSP controller are enabled. Note that ARM uses the word “masked” in the opposite sense from classic computer terminology, in which “masked” meant “disabled”. ARM uses the word “masked” to mean “enabled”. To avoid confusion we will not use the word “masked”.

Table 902: SSP Interrupt Mask Set/Clear register (IMSC - address 0x4008 3014 (SSP0), 0x400C 5014 (SSP1)) bit description

Bit	Symbol	Description	Reset value
0	RORIM	Software should set this bit to enable interrupt when a Receive Overrun occurs, that is, when the Rx FIFO is full and another frame is completely received. The ARM spec implies that the preceding frame data is overwritten by the new frame data when this occurs.	0
1	RTIM	Software should set this bit to enable interrupt when a Receive Time-out condition occurs. A Receive Time-out occurs when the Rx FIFO is not empty, and no has not been read for a time-out period. The time-out period is the same for master and slave modes and is determined by the SSP bit rate: 32 bits at PCLK / (CPSDVSR × [SCR+1]).	0
2	RXIM	Software should set this bit to enable interrupt when the Rx FIFO is at least half full.	0
3	TXIM	Software should set this bit to enable interrupt when the Tx FIFO is at least half empty.	0
31:4	-	Reserved, user software should not write ones to reserved bits. The value read from a reserved bit is not defined.	NA

40.6.7 SSP Raw Interrupt Status Register

This read-only register contains a 1 for each interrupt condition that is asserted, regardless of whether or not the interrupt is enabled in the SSPnIMSC.

Table 903: SSP Raw Interrupt Status register (RIS - address 0x4008 3018 (SSP0), RIS - 0x400C 5018 (SSP1)) bit description

Bit	Symbol	Description	Reset value
0	RORRIS	This bit is 1 if another frame was completely received while the Rx FIFO was full. The ARM spec implies that the preceding frame data is overwritten by the new frame data when this occurs.	0
1	RTRIS	This bit is 1 if the Rx FIFO is not empty, and has not been read for a time-out period. The time-out period is the same for master and slave modes and is determined by the SSP bit rate: 32 bits at PCLK / (CPSDVSR × [SCR+1]).	0
2	RXRIS	This bit is 1 if the Rx FIFO is at least half full.	0
3	TXRIS	This bit is 1 if the Tx FIFO is at least half empty.	1
31:4	-	Reserved, user software should not write ones to reserved bits. The value read from a reserved bit is not defined.	NA

40.6.8 SSP Masked Interrupt Status Register

This read-only register contains a 1 for each interrupt condition that is asserted and enabled in the SSPnIMSC. When an SSP interrupt occurs, the interrupt service routine should read this register to determine the cause(s) of the interrupt.

Table 904: SSP Masked Interrupt Status register (MIS -address 0x4008 301C (SSP0), 0x400C 501C (SSP1)) bit description

Bit	Symbol	Description	Reset value
0	RORMIS	This bit is 1 if another frame was completely received while the Rx FIFO was full, and this interrupt is enabled.	0
1	RTMIS	This bit is 1 if the Rx FIFO is not empty, has not been read for a time-out period, and this interrupt is enabled. The time-out period is the same for master and slave modes and is determined by the SSP bit rate: 32 bits at PCLK / (CPSDVSR × [SCR+1]).	0
2	RXMIS	This bit is 1 if the Rx FIFO is at least half full, and this interrupt is enabled.	0
3	TXMIS	This bit is 1 if the Tx FIFO is at least half empty, and this interrupt is enabled.	0
31:4	-	Reserved, user software should not write ones to reserved bits. The value read from a reserved bit is not defined.	NA

40.6.9 SSP Interrupt Clear Register

Software can write one or more one(s) to this write-only register, to clear the corresponding interrupt condition(s) in the SSP controller. Note that the other two interrupt conditions can be cleared by writing or reading the appropriate FIFO, or disabled by clearing the corresponding bit in SSPnIMSC.

Table 905: SSP interrupt Clear Register (ICR - address 0x4008 3020 (SSP0), ICR - 0x400C 5020 (SSP1)) bit description

Bit	Symbol	Description	Reset value
0	RORIC	Writing a 1 to this bit clears the “frame was received when Rx FIFO was full” interrupt.	NA
1	RTIC	Writing a 1 to this bit clears the Rx FIFO was not empty and has not been read for a time-out period interrupt. The time-out period is the same for master and slave modes and is determined by the SSP bit rate: 32 bits at PCLK / (CPSDVSR × [SCR+1]).	NA
31:2	-	Reserved, user software should not write ones to reserved bits. The value read from a reserved bit is not defined.	NA

40.6.10 SSP DMA Control Register

The SSPnDMACR register is the DMA control register. It is a read/write register.

Table 906: SSP DMA Control Register (DMACR - address 0x4008 3024 (SSP0), 0x400C 5024 (SSP1)) bit description

Bit	Symbol	Description	Reset value
0	RXDMAE	Receive DMA Enable. When this bit is set to one 1, DMA for the receive FIFO is enabled, otherwise receive DMA is disabled.	0
1	TXDMAE	Transmit DMA Enable. When this bit is set to one 1, DMA for the transmit FIFO is enabled, otherwise transmit DMA is disabled.	0
31:2	-	Reserved, user software should not write ones to reserved bits. The value read from a reserved bit is not defined.	NA

40.7 Functional description

40.7.1 Texas Instruments synchronous serial frame format

Figure 123 shows the 4-wire Texas Instruments synchronous serial frame format supported by the SSP module.

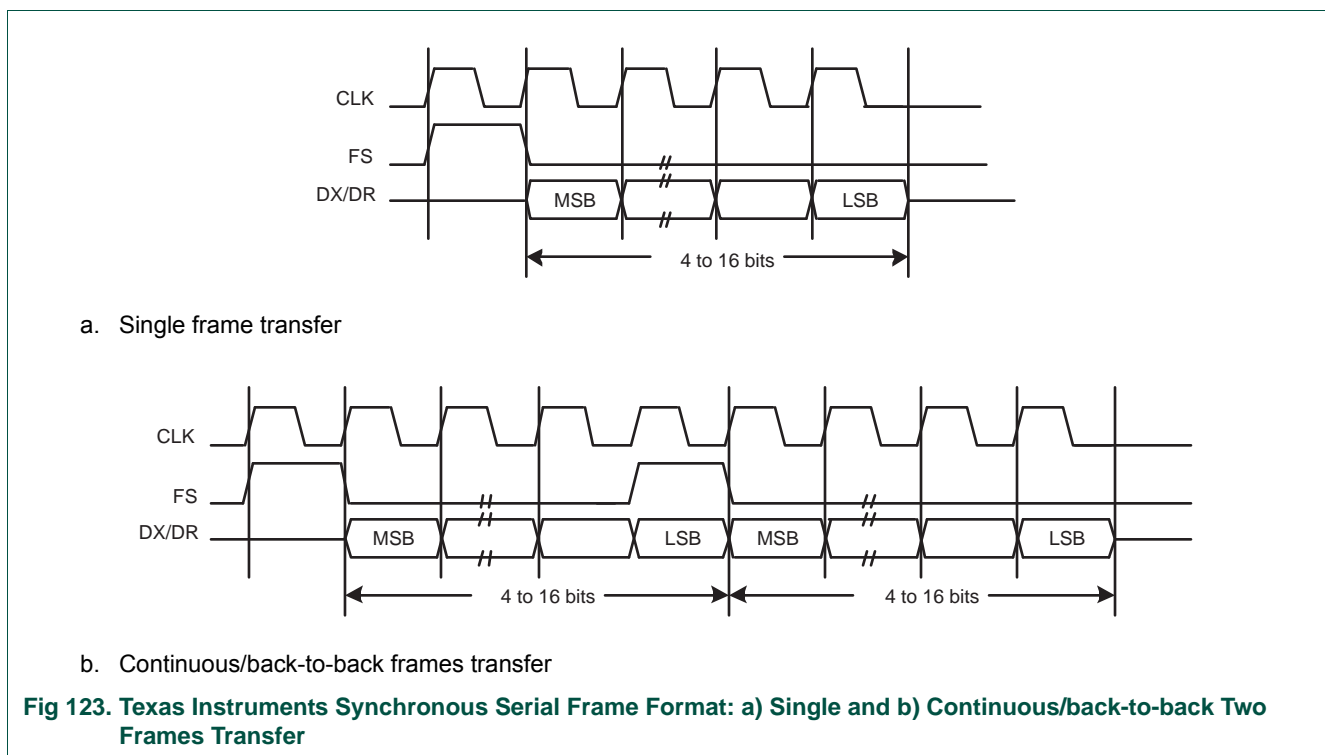

For device configured as a master in this mode, CLK and FS are forced LOW, and the transmit data line DX is tri-stated whenever the SSP is idle. Once the bottom entry of the transmit FIFO contains data, FS is pulsed HIGH for one CLK period. The value to be transmitted is also transferred from the transmit FIFO to the serial shift register of the transmit logic. On the next rising edge of CLK, the MSB of the 4-bit to 16-bit data frame is shifted out on the DX pin. Likewise, the MSB of the received data is shifted onto the DR pin by the off-chip serial slave device.

Both the SSP and the off-chip serial slave device then clock each data bit into their serial shifter on the falling edge of each CLK. The received data is transferred from the serial shifter to the receive FIFO on the first rising edge of CLK after the LSB has been latched.

40.7.2 SPI frame format

The SPI interface is a four-wire interface where the SSEL signal behaves as a slave select. The main feature of the SPI format is that the inactive state and phase of the SCK signal are programmable through the CPOL and CPHA bits within the SSPCR0 control register.

40.7.2.1 Clock Polarity (CPOL) and Phase (CPHA) control

When the CPOL clock polarity control bit is 0, it produces a steady state low value on the SCK pin. If the CPOL clock polarity control bit is 1, a steady state high value is placed on the CLK pin when data is not being transferred.

The CPHA control bit selects the clock edge that captures data and allows it to change state. It has the most impact on the first bit transmitted by either allowing or not allowing a clock transition before the first data capture edge. When the CPHA phase control bit is 0, data is captured on the first clock edge transition. If the CPHA clock phase control bit is 1, data is captured on the second clock edge transition.

40.7.2.2 SPI format with CPOL=0,CPHA=0

Single and continuous transmission signal sequences for SPI format with CPOL = 0, CPHA = 0 are shown in [Figure 124](#).

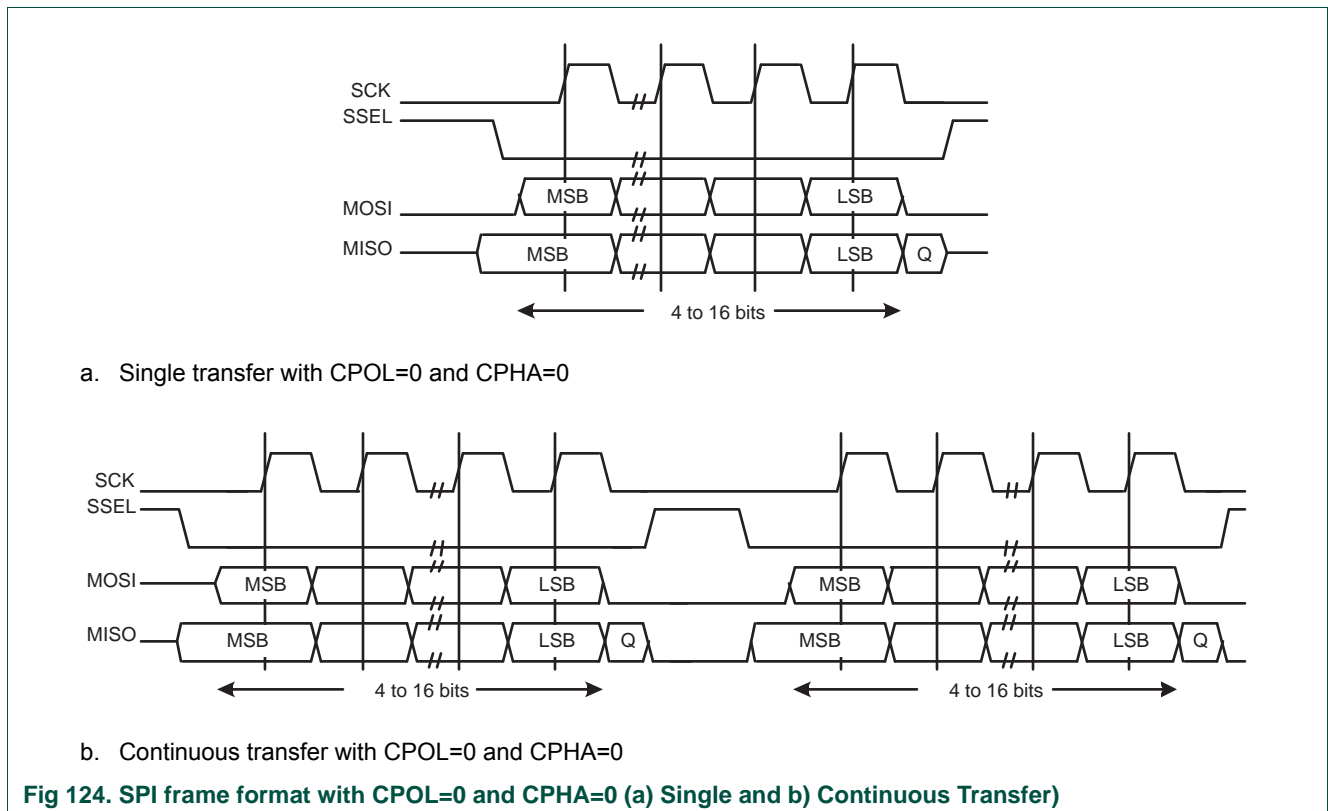

In this configuration, during idle periods:

- The CLK signal is forced LOW.
- SSEL is forced HIGH.
- The transmit MOSI/MISO pad is in high impedance.

If the SSP is enabled and there is valid data within the transmit FIFO, the start of transmission is signified by the SSEL master signal being driven LOW. This causes slave data to be enabled onto the MISO input line of the master. Master's MOSI is enabled.

One half SCK period later, valid master data is transferred to the MOSI pin. Now that both the master and slave data have been set, the SCK master clock pin goes HIGH after one further half SCK period.

The data is now captured on the rising and propagated on the falling edges of the SCK signal.

In the case of a single word transmission, after all bits of the data word have been transferred, the SSEL line is returned to its idle HIGH state one SCK period after the last bit has been captured.

However, in the case of continuous back-to-back transmissions, the SSEL signal must be pulsed HIGH between each data word transfer. This is because the slave select pin freezes the data in its serial peripheral register and does not allow it to be altered if the CPHA bit is logic zero. Therefore the master device must raise the SSEL pin of the slave device between each data transfer to enable the serial peripheral data write. On completion of the continuous transfer, the SSEL pin is returned to its idle state one SCK period after the last bit has been captured.

40.7.2.3 SPI format with CPOL=0,CPHA=1

The transfer signal sequence for SPI format with CPOL = 0, CPHA = 1 is shown in [Figure 125](#), which covers both single and continuous transfers.

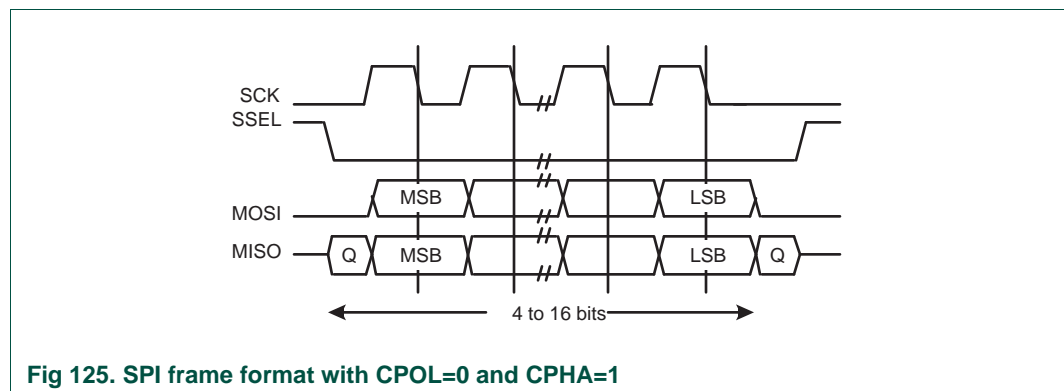

Fig 125. SPI frame format with CPOL=0 and CPHA=1

In this configuration, during idle periods:

- The CLK signal is forced LOW.
- SSEL is forced HIGH.
- The transmit MOSI/MISO pad is in high impedance.

If the SSP is enabled and there is valid data within the transmit FIFO, the start of transmission is signified by the SSEL master signal being driven LOW. Master's MOSI pin is enabled. After a further one half SCK period, both master and slave valid data is enabled onto their respective transmission lines. At the same time, the SCK is enabled with a rising edge transition.

Data is then captured on the falling edges and propagated on the rising edges of the SCK signal.

In the case of a single word transfer, after all bits have been transferred, the SSEL line is returned to its idle HIGH state one SCK period after the last bit has been captured.

For continuous back-to-back transfers, the SSEL pin is held LOW between successive data words and termination is the same as that of the single word transfer.

40.7.2.4 SPI format with CPOL = 1,CPHA = 0

Single and continuous transmission signal sequences for SPI format with CPOL=1, CPHA=0 are shown in [Figure 126](#).

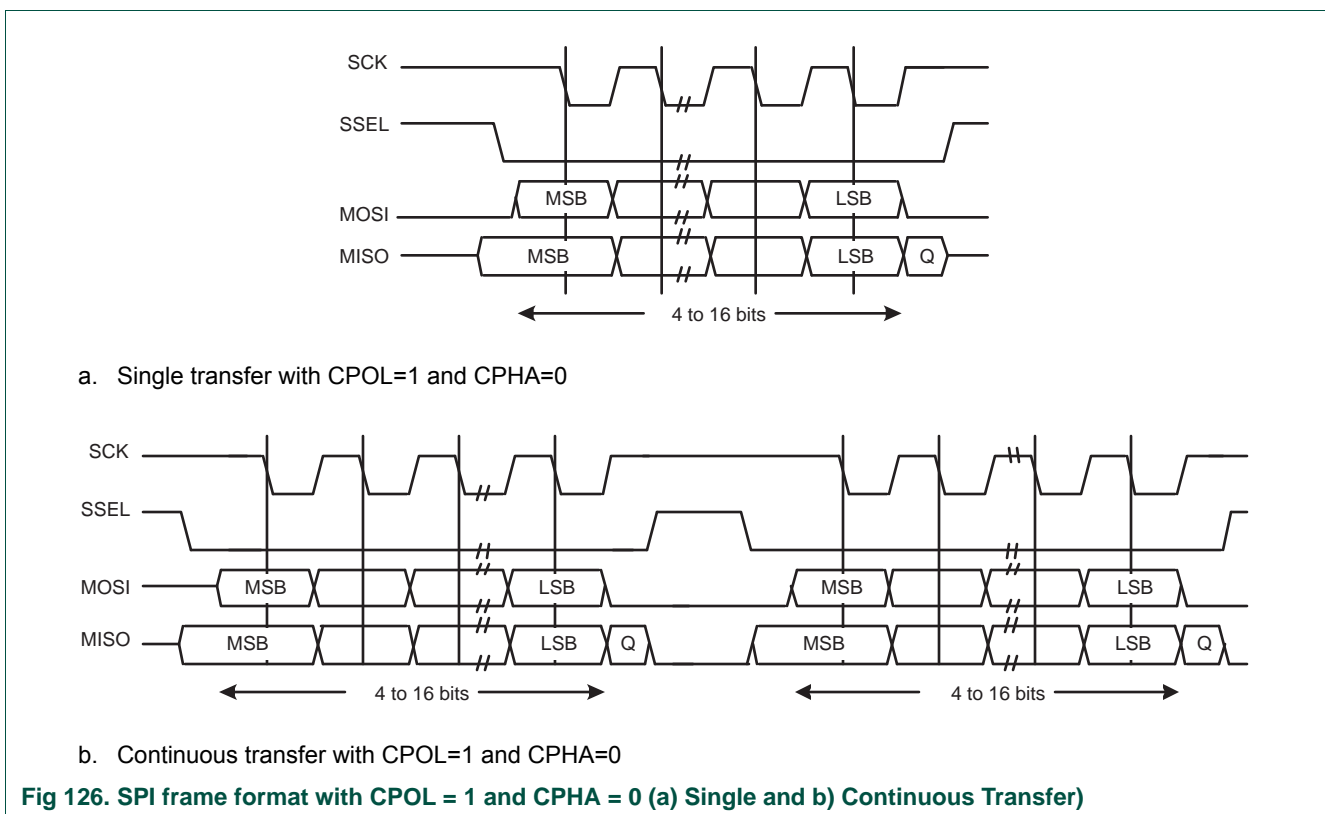

In this configuration, during idle periods:

- The CLK signal is forced HIGH.
- SSEL is forced HIGH.
- The transmit MOSI/MISO pad is in high impedance.

If the SSP is enabled and there is valid data within the transmit FIFO, the start of transmission is signified by the SSEL master signal being driven LOW, which causes slave data to be immediately transferred onto the MISO line of the master. Master's MOSI pin is enabled.

One half period later, valid master data is transferred to the MOSI line. Now that both the master and slave data have been set, the SCK master clock pin becomes LOW after one further half SCK period. This means that data is captured on the falling edges and be propagated on the rising edges of the SCK signal.

In the case of a single word transmission, after all bits of the data word are transferred, the SSEL line is returned to its idle HIGH state one SCK period after the last bit has been captured.

However, in the case of continuous back-to-back transmissions, the SSEL signal must be pulsed HIGH between each data word transfer. This is because the slave select pin freezes the data in its serial peripheral register and does not allow it to be altered if the CPHA bit is logic zero. Therefore the master device must raise the SSEL pin of the slave device between each data transfer to enable the serial peripheral data write. On completion of the continuous transfer, the SSEL pin is returned to its idle state one SCK period after the last bit has been captured.

40.7.2.5 SPI format with CPOL = 1,CPHA = 1

The transfer signal sequence for SPI format with CPOL = 1, CPHA = 1 is shown in [Figure 127](#), which covers both single and continuous transfers.

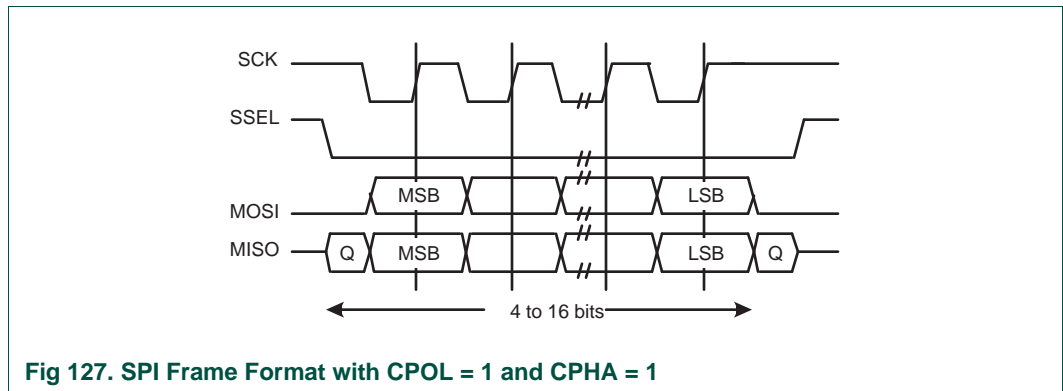

In this configuration, during idle periods:

- The CLK signal is forced HIGH.
- SSEL is forced HIGH.
- The transmit MOSI/MISO pad is in high impedance.

If the SSP is enabled and there is valid data within the transmit FIFO, the start of transmission is signified by the SSEL master signal being driven LOW. Master's MOSI is enabled. After a further one half SCK period, both master and slave data are enabled onto their respective transmission lines. At the same time, the SCK is enabled with a falling edge transition. Data is then captured on the rising edges and propagated on the falling edges of the SCK signal.

After all bits have been transferred, in the case of a single word transmission, the SSEL line is returned to its idle HIGH state one SCK period after the last bit has been captured. For continuous back-to-back transmissions, the SSEL pins remains in its active LOW state, until the final bit of the last word has been captured, and then returns to its idle state as described above. In general, for continuous back-to-back transfers the SSEL pin is held LOW between successive data words and termination is the same as that of the single word transfer.

40.7.3 National Semiconductor Microwire frame format

Figure 128 shows the Microwire frame format for a single frame. Figure 129 shows the same format when back-to-back frames are transmitted.

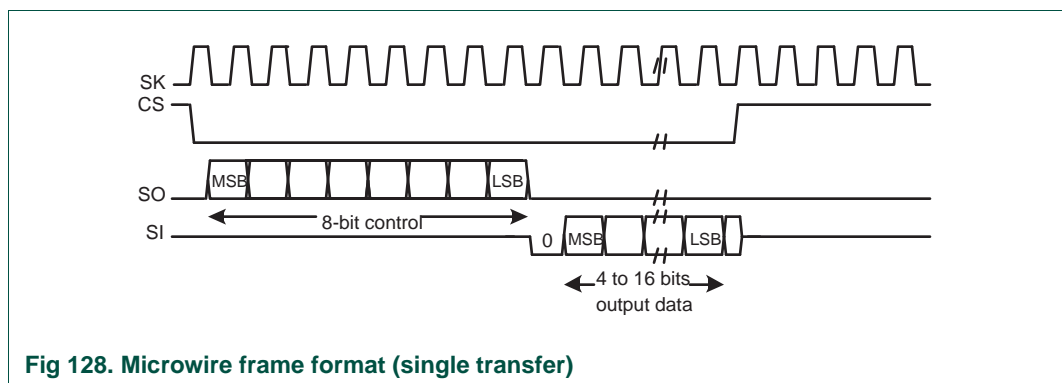

Fig 128. Microwire frame format (single transfer)

Microwire format is very similar to SPI format, except that transmission is half-duplex instead of full-duplex, using a master-slave message passing technique. Each serial transmission begins with an 8-bit control word that is transmitted from the SSP to the off-chip slave device. During this transmission, no incoming data is received by the SSP. After the message has been sent, the off-chip slave decodes it and, after waiting one serial clock after the last bit of the 8-bit control message has been sent, responds with the required data. The returned data is 4 to 16 bits in length, making the total frame length anywhere from 13 to 25 bits.

In this configuration, during idle periods:

- The SK signal is forced LOW.
- CS is forced HIGH.
- The transmit data line SO is arbitrarily forced LOW.

A transmission is triggered by writing a control byte to the transmit FIFO. The falling edge of CS causes the value contained in the bottom entry of the transmit FIFO to be transferred to the serial shift register of the transmit logic, and the MSB of the 8-bit control frame to be shifted out onto the SO pin. CS remains LOW for the duration of the frame transmission. The SI pin remains tristated during this transmission.

The off-chip serial slave device latches each control bit into its serial shifter on the rising edge of each SK. After the last bit is latched by the slave device, the control byte is decoded during a one clock wait-state, and the slave responds by transmitting data back to the SSP. Each bit is driven onto SI line on the falling edge of SK. The SSP in turn

latches each bit on the rising edge of SK. At the end of the frame, for single transfers, the CS signal is pulled HIGH one clock period after the last bit has been latched in the receive serial shifter, that causes the data to be transferred to the receive FIFO.

Note: The off-chip slave device can tristate the receive line either on the falling edge of SK after the LSB has been latched by the receive shifter, or when the CS pin goes HIGH.

For continuous transfers, data transmission begins and ends in the same manner as a single transfer. However, the CS line is continuously asserted (held LOW) and transmission of data occurs back to back. The control byte of the next frame follows directly after the LSB of the received data from the current frame. Each of the received values is transferred from the receive shifter on the falling edge SK, after the LSB of the frame has been latched into the SSP.

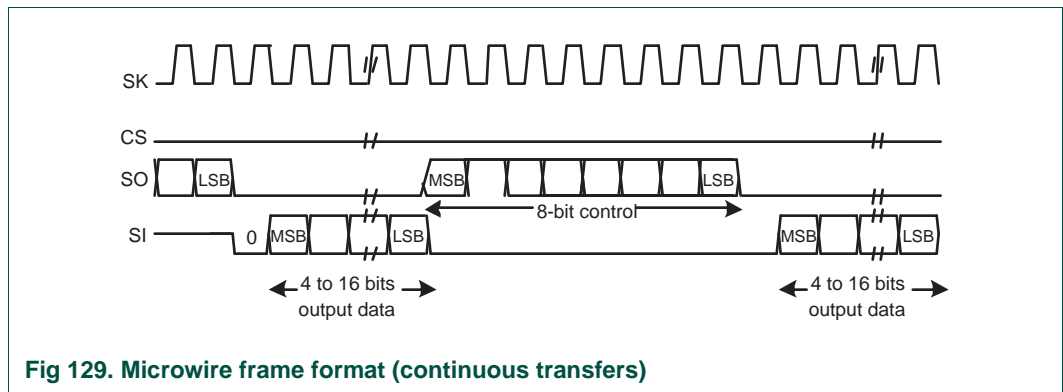

40.7.3.1 Setup and hold time requirements on CS with respect to SK in Microwire mode

In the Microwire mode, the SSP slave samples the first bit of receive data on the rising edge of SK after CS has gone LOW. Masters that drive a free-running SK must ensure that the CS signal has sufficient setup and hold margins with respect to the rising edge of SK.

Figure 130 illustrates these setup and hold time requirements. With respect to the SK rising edge on which the first bit of receive data is to be sampled by the SSP slave, CS must have a setup of at least two times the period of SK on which the SSP operates. With respect to the SK rising edge previous to this edge, CS must have a hold of at least one SK period.

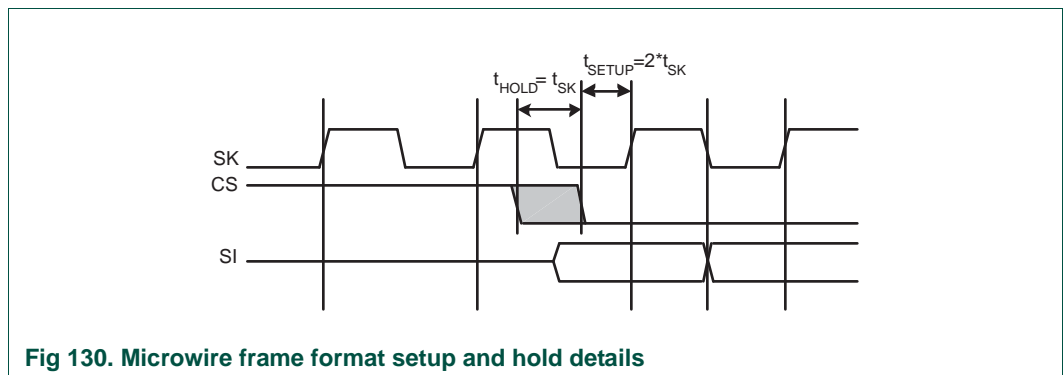

41.1 How to read this chapter

The I²S0/1 interfaces are available on all LPC18xx parts.

41.2 Basic configuration

The I²S interface is configured as follows:

- See [Table 907](#) for clocking and power control.
- The I2S0 is reset by the I2S0_RST (reset # 52).
- The I2S1 is reset by the I2S1_RST (reset # 53).
- The I2S0 interrupt is connected to slot # 28 in the NVIC.
- The I2S1 interrupt is connected to slot # 29 in the NVIC.
- For connecting the I2S receive and transmit lines to the GPDMA, use the DMAMUX register in the CREG block (see [Table 92](#)) and enable the GPDMA channel in the DMA Channel Configuration registers ([Section 19.6.20](#)).
- The I2S clock can be sourced directly from the CGU using the BASE_AUDIO_CLK. See [Table 96](#) for configuring the I2S clock inputs for the BASE_AUDIO_CLK.
- The I2S0/1 MWS signals (I2S0_RX_MWS/I2S0_TX_MWS/IS1_RX_MWS/I2S1_TX_MWS) can be connected to Timer3 or the SCT through the GIMA (see [Table 190](#)).

Table 907. I2S clocking and power control

	Base clock	Branch clock	Operating frequency
Clock to the I2S0 and I2S1 register interface and I2S0/1 peripheral clock.	BASE_APB1_CLK	CLK_APB1_I2S	up to 180 MHz

41.3 Features

The I2S bus provides a standard communication interface for digital audio applications.

The I2S bus specification defines a 3-wire serial bus, having one data, one clock, and one word select signal. The basic I2S connection has one master, which is always the master, and one slave. The I2S interface provides a separate transmit and receive channel, each of which can operate as either a master or a slave.

- The I2S input can operate in both master and slave mode, independently of the I2S output.
- The I2S output can operate in both master and slave mode, independently of the I2S input.
- Capable of handling 8-bit, 16-bit, and 32-bit word sizes.
- Mono and stereo audio data supported.

- Versatile clocking includes independent transmit and receive fractional rate generators, and an ability to use a single clock input or output for a 4-wire mode.
- The sampling frequency (f_s) can range (in practice) from 16 to 192 kHz (16, 22.05, 32, 44.1, 48, 96, or 192 kHz) for audio applications.
- Separate Master Clock outputs for both transmit and receive channels support a clock up to 512 times the I²S sampling frequency.
- Word Select period in master mode is configurable (separately for I²S input and I²S output).
- Two 8 word (32 byte) FIFO data buffers are provided, one for transmit and one for receive.
- Generates interrupt requests when buffer levels cross a programmable boundary.
- Two DMA requests, controlled by programmable buffer levels. These are connected to the General Purpose DMA block.
- Controls include reset, stop and mute options separately for I2S input and I2S output.

41.4 General description

The I2S performs serial data out via the transmit channel and serial data in via the receive channel. These support the Inter IC Audio format for 8-bit, 16-bit and 32-bit audio data, both for stereo and mono modes. Configuration, data access and control is performed by a APB register set. Data streams are buffered by FIFOs with a depth of 8 words.

The I2S receive and transmit stage can operate independently in either slave or master mode. In master mode, the I2S module supplies the SCK and WS signals. In slave mode, the SCK and WS signals are provided by the external master.

- In master mode, word select is generated internally with a 9-bit counter. The ratio of the SCK and WS signals can be programmed in the control register.
- In slave mode, word select is input from the relevant bus pin.
- When an I2S bus is active, the word select, receive clock and transmit clock signals are sent continuously by the bus master, while data is sent continuously by the transmitter.
- Disabling the I2S can be done with the stop or mute control bits separately for the transmit and receive.
- The stop bit will disable accesses by the transmit channel or the receive channel to the FIFOs and will place the transmit channel in mute mode.
- The mute control bit will place the transmit channel in mute mode. In mute mode, the transmit channel FIFO operates normally, but the output is discarded and replaced by zeroes. This bit does not affect the receive channel, data reception can occur normally.

41.4.1 I2S connection schemes

I2S1 is automatically a slave to I2S0 if no external pins are selected for the I2S1 clock and data lines.

MCLK can be provided by a master or used by the master to create the I2S SCK. MCLK can also be generated internally by the audio PLL through the CREG block (see [Table 96](#)).

41.4.2 I2S connections to the GIMA

The Word Select (MWS) signal is generated by the I2S blocks in slave and master mode to capture or generate data. MWS either originates either from the pin mux (SCU) in slave mode (the I2S_WS signal) or is generated by the I2S block in master mode. The MWS signal is then routed to the SCU (in master mode only) and to the GIMA where it can be selected as input to Timer3 or the SCT. The MWS signal which is connected to the GIMA, is divided by 128.

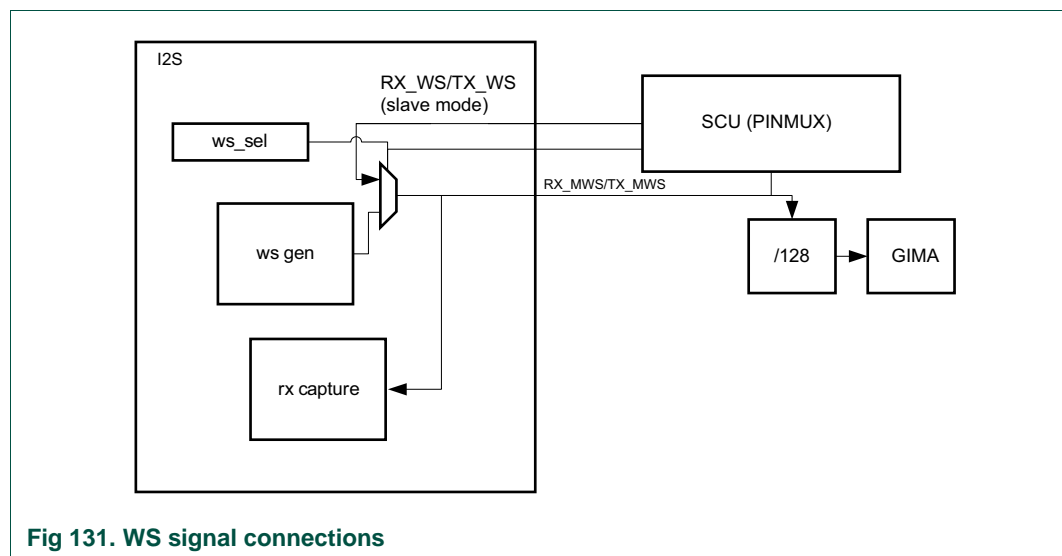

Fig 131. WS signal connections

41.5 Pin description

Table 908. Pin description

Pin function	Direction	Description
I2S0/1_RX_SCK	Input/ Output	Receive Clock. A clock signal used to synchronize the transfer of data on the receive channel. It is driven by the master and received by the slave. Corresponds to the signal SCK in the I2S bus specification.
I2S0/1_RX_WS	Input/ Output	Receive Word Select. Selects the channel from which data is to be received. It is driven by the master and received by the slave. Corresponds to the signal WS in the I2S bus specification. WS = 0 indicates that data is being received by channel 1 (left channel). WS = 1 indicates that data is being received by channel 2 (right channel).
I2S0/1_RX_SDA	Input/ Output	Receive Data. Serial data, received MSB first. It is driven by the transmitter and read by the receiver. Corresponds to the signal SD in the I2S bus specification.
I2S0/1_RX_MCLK	Output	Optional master clock output for the I2S receive function.
I2S0/1_TX_SCK	Input/ Output	Transmit Clock. A clock signal used to synchronize the transfer of data on the transmit channel. It is driven by the master and received by the slave. Corresponds to the signal SCK in the I2S bus specification.
I2S0/1_TX_WS	Input/ Output	Transmit Word Select. Selects the channel to which data is being sent. It is driven by the master and received by the slave. Corresponds to the signal WS in the I2S bus specification. WS = 0 indicates that data is being sent to channel 1 (left channel). WS = 1 indicates that data is being sent to channel 2 (right channel).
I2S0/1_TX_SDA	Input/ Output	Transmit Data. Serial data, sent MSB first. It is driven by the transmitter and read by the receiver. Corresponds to the signal SD in the I2S bus specification.
IS0/1_TX_MCLK	Output	Optional master clock output for the I2S transmit function.

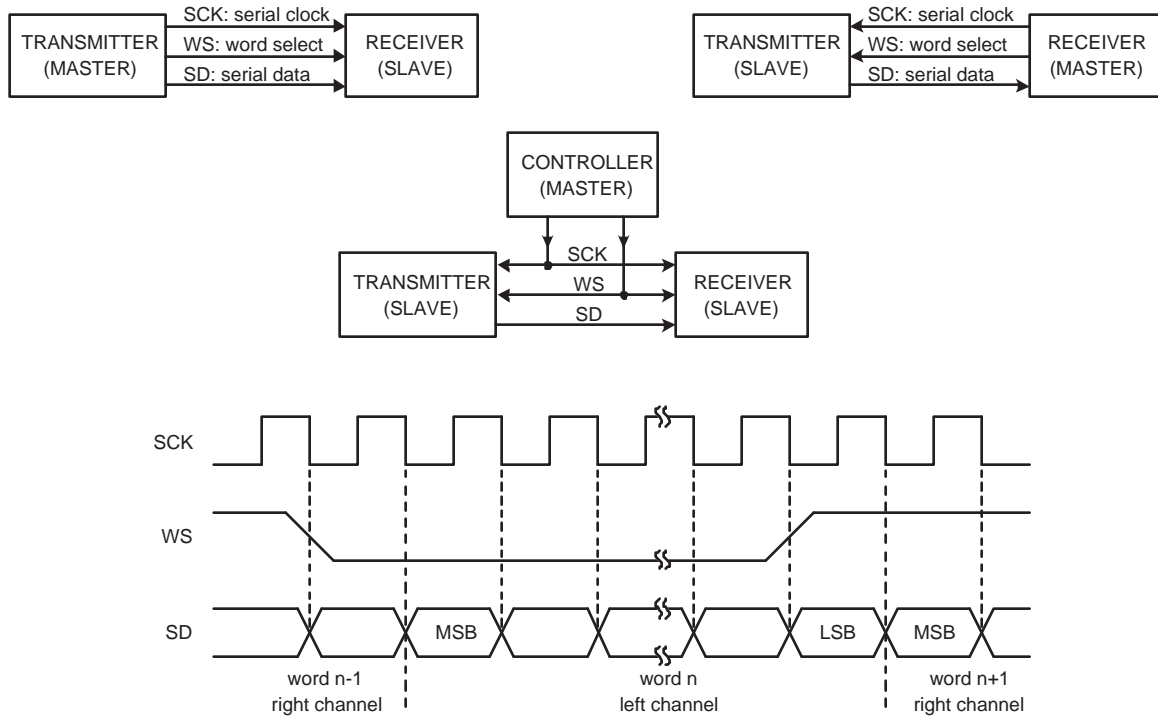

Fig 132. Simple I2S configurations and bus timing

41.6 Register description

[Table 909](#) shows the registers associated with the I2S interface and a summary of their functions. Following the table are details for each register.

Reset value reflects the data stored in used bits only. It does not include reserved bits content.

Table 909. Register overview: I2S0 (base address 0x400A 2000)

Name	Access	Address offset	Description	Reset value	Reference
DAO	R/W	0x000	I2S Digital Audio Output Register. Contains control bits for the I2S transmit channel.	0x87E1	Table 911
DAI	R/W	0x004	I2S Digital Audio Input Register. Contains control bits for the I2S receive channel.	0x07E1	Table 912
TXFIFO	WO	0x008	I2S Transmit FIFO. Access register for the 8 x 32-bit transmitter FIFO.	0	Table 913
RXFIFO	RO	0x00C	I2S Receive FIFO. Access register for the 8 x 32-bit receiver FIFO.	0	Table 914
STATE	RO	0x010	I2S Status Feedback Register. Contains status information about the I2S interface.	0x7	Table 915
DMA1	R/W	0x014	I2S DMA Configuration Register 1. Contains control information for DMA request 1.	0	Table 916
DMA2	R/W	0x018	I2S DMA Configuration Register 2. Contains control information for DMA request 2.	0	Table 917
IRQ	R/W	0x01C	I2S Interrupt Request Control Register. Contains bits that control how the I2S interrupt request is generated.	0	Table 918
TXRATE	R/W	0x020	I2S Transmit MCLK divider. This register determines the I2S TX MCLK rate by specifying the value to divide PCLK by in order to produce MCLK.	0	Table 919
RXRATE	R/W	0x024	I2S Receive MCLK divider. This register determines the I2S RX MCLK rate by specifying the value to divide PCLK by in order to produce MCLK.	0	Table 920
TXBITRATE	R/W	0x028	I2S Transmit bit rate divider. This register determines the I2S transmit bit rate by specifying the value to divide TX_MCLK by in order to produce the transmit bit clock.	0	Table 921
RXBITRATE	R/W	0x02C	I2S Receive bit rate divider. This register determines the I2S receive bit rate by specifying the value to divide RX_MCLK by in order to produce the receive bit clock.	0	Table 922
TXMODE	R/W	0x030	I2S Transmit mode control.	0	Table 923
RXMODE	R/W	0x034	I2S Receive mode control.	0	Table 924

Table 910. Register overview: I2S1 (base address 0x400A 3000)

Name	Access	Address offset	Description	Reset value	Reference
DAO	R/W	0x000	I2S Digital Audio Output Register. Contains control bits for the I2S transmit channel.	0x87E1	Table 911
DAI	R/W	0x004	I2S Digital Audio Input Register. Contains control bits for the I2S receive channel.	0x07E1	Table 912
TXFIFO	WO	0x008	I2S Transmit FIFO. Access register for the 8 x 32-bit transmitter FIFO.	0	Table 913
RXFIFO	RO	0x00C	I2S Receive FIFO. Access register for the 8 x 32-bit receiver FIFO.	0	Table 914
STATE	RO	0x010	I2S Status Feedback Register. Contains status information about the I2S interface.	0x7	Table 915
DMA1	R/W	0x014	I2S DMA Configuration Register 1. Contains control information for DMA request 1.	0	Table 916
DMA2	R/W	0x018	I2S DMA Configuration Register 2. Contains control information for DMA request 2.	0	Table 917
IRQ	R/W	0x01C	I2S Interrupt Request Control Register. Contains bits that control how the I2S interrupt request is generated.	0	Table 918
TXRATE	R/W	0x020	I2S Transmit MCLK divider. This register determines the I2S TX MCLK rate by specifying the value to divide PCLK by in order to produce MCLK.	0	Table 919
RXRATE	R/W	0x024	I2S Receive MCLK divider. This register determines the I2S RX MCLK rate by specifying the value to divide PCLK by in order to produce MCLK.	0	Table 920
TXBITRATE	R/W	0x028	I2S Transmit bit rate divider. This register determines the I2S transmit bit rate by specifying the value to divide TX_MCLK by in order to produce the transmit bit clock.	0	Table 921
RXBITRATE	R/W	0x02C	I2S Receive bit rate divider. This register determines the I2S receive bit rate by specifying the value to divide RX_MCLK by in order to produce the receive bit clock.	0	Table 922
TXMODE	R/W	0x030	I2S Transmit mode control.	0	Table 923
RXMODE	R/W	0x034	I2S Receive mode control.	0	Table 924

41.6.1 I2S Digital Audio Output register

The DAO register controls the operation of the I2S transmit channel. The function of bits in DAO are shown in [Table 911](#).

Table 911. I2S Digital Audio Output register (DAO, address 0x400A 2000 (I2S0) and 0x400A 3000 (I2S1)) bit description

Bit	Symbol	Value	Description	Reset value
1:0	WORDWIDTH		Selects the number of bytes in data as follows:	01
		0x0	8-bit data	
		0x1	16-bit data	
		0x2	Reserved, do not use this setting	
		0x3	32-bit data	
2	MONO		When 1, data is of monaural format. When 0, the data is in stereo format.	0

Table 911. I2S Digital Audio Output register (DAO, address 0x400A 2000 (I2S0) and 0x400A 3000 (I2S1)) bit description

Bit	Symbol	Value	Description	Reset value
3	STOP		When 1, disables accesses on FIFOs, places the transmit channel in mute mode.	0
4	RESET		When 1, asynchronously resets the transmit channel and FIFO.	0
5	WS_SEL		When 0, the interface is in master mode. When 1, the interface is in slave mode.	1
14:6	WS_HALFPERIOD		Word select half period minus 1, i.e. WS 64clk period -> ws_halfperiod = 31.	0x1F
15	MUTE		When 1, the transmit channel sends only zeroes.	1
31:16	-		Reserved, user software should not write ones to reserved bits. The value read from a reserved bit is not defined.	-

41.6.2 I2S Digital Audio Input register

The DAI register controls the operation of the I2S receive channel. The function of bits in DAI are shown in [Table 912](#).

Table 912. I2S Digital Audio Input register (DAI, address 0x400A 2004 (I2S0) and 0x400A 3004 (I2S1)) bit description

Bit	Symbol	Value	Description	Reset value
1:0	WORDWIDTH		Selects the number of bytes in data as follows:	01
		0x0	8-bit data	
		0x1	16-bit data	
		0x2	Reserved, do not use this setting	
		0x3	32-bit data	
2	MONO		When 1, data is of monaural format. When 0, the data is in stereo format.	0
3	STOP		When 1, disables accesses on FIFOs, places the transmit channel in mute mode.	0
4	RESET		When 1, asynchronously reset the transmit channel and FIFO.	0
5	WS_SEL		When 0, the interface is in master mode. When 1, the interface is in slave mode.	1
14:6	WS_HALFPERIOD		Word select half period minus 1, i.e. WS 64clk period -> ws_halfperiod = 31.	0x1F
31:15	-		Reserved, user software should not write ones to reserved bits. The value read from a reserved bit is not defined.	-

41.6.3 I2S Transmit FIFO register

The TXFIFO register provides access to the transmit FIFO.

Table 913. Transmit FIFO register (TXFIFO, address 0x400A 2008 (I2S0) and 0x400A 3008 (I2S1)) bit description

Bit	Symbol	Description	Reset value
31:0	I2STXFIFO	8 x 32-bit transmit FIFO.	0

41.6.4 Receive FIFO register

The I2SRXFIFO register provides access to the receive FIFO.

Table 914. I2S Receive FIFO register (RXFIFO, address 0x400A 200C (I2S0) and 0x400A 300C (I2S1)) bit description

Bit	Symbol	Description	Reset value
31:0	I2SRXFIFO	8 x 32-bit receive FIFO.	0

41.6.5 I2S Status Feedback register

The STATE register provides status information about the I2S interface.

Table 915. I2S Status Feedback register (STATE, address 0x400A 2010 (I2S0) and 0x400A 3010 (I2S1)) bit description

Bit	Symbol	Description	Reset value
0	IRQ	This bit reflects the presence of Receive Interrupt or Transmit Interrupt. This is determined by comparing the current FIFO levels to the rx_depth_irq and tx_depth_irq fields in the IRQ register.	1
1	DMAREQ1	This bit reflects the presence of Receive or Transmit DMA Request 1. This is determined by comparing the current FIFO levels to the rx_depth_dma1 and tx_depth_dma1 fields in the DMA1 register.	1
2	DMAREQ2	This bit reflects the presence of Receive or Transmit DMA Request 2. This is determined by comparing the current FIFO levels to the rx_depth_dma2 and tx_depth_dma2 fields in the DMA2 register.	1
7:3	-	Reserved.	0
11:8	RX_LEVEL	Reflects the current level of the Receive FIFO.	0
15:12	-	Reserved, user software should not write ones to reserved bits. The value read from a reserved bit is not defined.	-
19:16	TX_LEVEL	Reflects the current level of the Transmit FIFO.	0
31:20	-	Reserved, user software should not write ones to reserved bits. The value read from a reserved bit is not defined.	-

41.6.6 I2S DMA Configuration Register 1

The DMA1 register controls the operation of DMA request 1. The function of bits in DMA1 are shown in [Table 916](#). Refer to [Chapter 19 “LPC18xx General Purpose DMA \(GPDMA\) controller”](#) for details of DMA operation.

This register enables the DMA for the I²S receive and transmit channels and sets the FIFO level.

Remark: The FIFOs contain eight 32 bit Dwords. Therefore, if the I²S controller is configured for 32-bit mode (see [Table 911](#) and [Table 912](#)), the maximum allowed FIFO level is 4.

Table 916. I2S DMA Configuration register 1 (DMA1, address 0x400A 2014 (I2S0) and 0x400A 3014 (I2S1)) bit description

Bit	Symbol	Description	Reset value
0	RX_DMA1_ENABLE	When 1, enables DMA1 for I2S receive.	0
1	TX_DMA1_ENABLE	When 1, enables DMA1 for I2S transmit.	0
7:2	-	Reserved, user software should not write ones to reserved bits. The value read from a reserved bit is not defined.	0
11:8	RX_DEPTH_DMA1	Set the FIFO level that triggers a receive DMA request on DMA1.	0

Table 916. I2S DMA Configuration register 1 (DMA1, address 0x400A 2014 (I2S0) and 0x400A 3014 (I2S1)) bit description

Bit	Symbol	Description	Reset value
15:12	-	Reserved, user software should not write ones to reserved bits. The value read from a reserved bit is not defined.	-
19:16	TX_DEPTH_DMA1	Set the FIFO level that triggers a transmit DMA request on DMA1.	0
31:20	-	Reserved, user software should not write ones to reserved bits. The value read from a reserved bit is not defined.	-

41.6.7 I2S DMA Configuration Register 2

The DMA2 register controls the operation of DMA request 2. The function of bits in DMA2 are shown in [Table 911](#).

This register enables the DMA for the I²S receive and transmit channels and sets the FIFO level.

Remark: The FIFOs contain eight 32 bit Dwords. Therefore, if the I²S controller is configured for 32-bit mode (see [Table 911](#) and [Table 912](#)), the maximum allowed FIFO level is 4.

Table 917. I2S DMA Configuration register 2 (DMA2, address 0x400A 2018 (I2S0) and 0x400A 3018 (I2S1)) bit description

Bit	Symbol	Description	Reset value
0	RX_DMA2_ENABLE	When 1, enables DMA1 for I2S receive.	0
1	TX_DMA2_ENABLE	When 1, enables DMA1 for I2S transmit.	0
7:2	-	Reserved.	0
11:8	RX_DEPTH_DMA2	Set the FIFO level that triggers a receive DMA request on DMA2.	0
15:12	-	Reserved, user software should not write ones to reserved bits. The value read from a reserved bit is not defined.	-
19:16	TX_DEPTH_DMA2	Set the FIFO level that triggers a transmit DMA request on DMA2.	0
31:20	-	Reserved, user software should not write ones to reserved bits. The value read from a reserved bit is not defined.	-

41.6.8 I2S Interrupt Request Control register

The IRQ register controls the operation of the I2S interrupt request. The function of bits in IRQ are shown in [Table 911](#).

Table 918. I2S Interrupt Request Control register (IRQ, address 0x400A 201C (I2S0) and 0x400A 301C (I2S1)) bit description

Bit	Symbol	Description	Reset value
0	RX_IRQ_ENABLE	When 1, enables I2S receive interrupt.	0
1	TX_IRQ_ENABLE	When 1, enables I2S transmit interrupt.	0
7:2	-	Reserved.	0
11:8	RX_DEPTH_IRQ	Set the FIFO level on which to create an irq request.	0

Table 918. I2S Interrupt Request Control register (IRQ, address 0x400A 201C (I2S0) and 0x400A 301C (I2S1)) bit description

Bit	Symbol	Description	Reset value
15:12	-	Reserved, user software should not write ones to reserved bits. The value read from a reserved bit is not defined.	-
19:16	TX_DEPTH_IRQ	Set the FIFO level on which to create an irq request.	0
31:20	-	Reserved, user software should not write ones to reserved bits. The value read from a reserved bit is not defined.	-

41.6.9 I2S Transmit Clock Rate register

The MCLK rate for the I2S transmitter is determined by the values in the TXRATE register. The required TXRATE setting depends on the desired audio sample rate, the format (stereo/mono) used, and the data size.

The transmitter MCLK rate is generated using a fractional rate generator, dividing down the frequency of PCLK = CLK_APB1_I2S. Values of the numerator (X) and the denominator (Y) must be chosen to produce a frequency twice that desired for the transmitter MCLK, which must be an integer multiple of the transmitter bit clock rate. Fractional rate generators have some aspects that the user should be aware of when choosing settings. These are discussed in [Section 41.6.9.1](#). The equation for the fractional rate generator is:

$$I2S_TX_MCLK = PCLK * (X/Y) / 2$$

Note: If the value of X or Y is 0, then no clock is generated. Also, the value of Y must be greater than or equal to X.

Table 919. I2S Transmit Clock Rate register (TXRATE, address 0x400A 2020 (I2S0) and 0x400A 3020 (I2S1)) bit description

Bit	Symbol	Description	Reset value
7:0	Y_DIVIDER	I2S transmit MCLK rate denominator. This value is used to divide PCLK to produce the transmit MCLK. Eight bits of fractional divide supports a wide range of possibilities. A value of 0 stops the clock.	0
15:8	X_DIVIDER	I2S transmit MCLK rate numerator. This value is used to multiply PCLK by to produce the transmit MCLK. A value of 0 stops the clock. Eight bits of fractional divide supports a wide range of possibilities. Note: the resulting ratio X/Y is divided by 2.	0
31:16	-	Reserved, user software should not write ones to reserved bits. The value read from a reserved bit is not defined.	-

41.6.9.1 Notes on fractional rate generators

A fractional rate generator can introduce output jitter with some divide settings. This is because the fractional rate generator is a fully digital function, so the output clock transitions are synchronous with the source clock, whereas a theoretical perfect fractional rate may have edges that are not related to the source clock. Therefore the output jitter will not be greater than plus or minus one source clock between consecutive clock edges.

For example, if X = 0x07 and Y = 0x11, the fractional rate generator will output 7 clocks for every 17 (11 hex) input clocks, distributed as evenly as it can. In this example, there is no way to distribute the output clocks in a perfectly even fashion, so some clocks will be longer than others. The output is divided by 2 in order to square it up, which also helps

with the jitter. The frequency averages out to exactly $(7/17) / 2$, but some clocks will be a slightly different length than their neighbors. It is possible to avoid jitter entirely by choosing fractions such that X divides evenly into Y, such as 2/4, 2/6, 3/9, 1/N, etc.

41.6.10 I2S Receive Clock Rate register

The MCLK rate for the I2S receiver is determined by the values in the RXRATE register. The required RXRATE setting depends on the peripheral clock rate (PCLK_I2S = CLK_APB1_I2S) and the desired MCLK rate (such as 256 fs).

The receiver MCLK rate is generated using a fractional rate generator, dividing down the frequency of PCLK_I2S. Values of the numerator (X) and the denominator (Y) must be chosen to produce a frequency twice that desired for the receiver MCLK, which must be an integer multiple of the receiver bit clock rate. Fractional rate generators have some aspects that the user should be aware of when choosing settings. These are discussed in [Section 41.6.9.1](#). The equation for the fractional rate generator is:

$$I2S_RX_MCLK = PCLK_I2S * (X/Y) / 2$$

Note: If the value of X or Y is 0, then no clock is generated. Also, the value of Y must be greater than or equal to X.

Table 920. I2S Receive Clock Rate register (RXRATE, address 0x400A 2024 (I2S0) and 0x400A 3024 (I2S1)) bit description

Bit	Symbol	Description	Reset value
7:0	Y_DIVIDER	I2S receive MCLK rate denominator. This value is used to divide PCLK to produce the receive MCLK. Eight bits of fractional divide supports a wide range of possibilities. A value of 0 stops the clock.	0
15:8	X_DIVIDER	I2S receive MCLK rate numerator. This value is used to multiply PCLK by to produce the receive MCLK. A value of 0 stops the clock. Eight bits of fractional divide supports a wide range of possibilities. Note: the resulting ratio X/Y is divided by 2.	0
31:16	-	Reserved, user software should not write ones to reserved bits. The value read from a reserved bit is not defined.	-

41.6.11 I2S Transmit Clock Bit Rate register

The bit rate for the I2S transmitter is determined by the value of the TXBITRATE register. The value depends on the audio sample rate desired and the data size and format (stereo/mono) used. For example, a 48 kHz sample rate for 16-bit stereo data requires a bit rate of $48\ 000 \times 16 \times 2 = 1.536$ MHz.

Table 921. I2S Transmit Clock Rate register (TXBITRATE, address 0x400A 2028 (I2S0) and 0x400A 3028 (I2S1)) bit description

Bit	Symbol	Description	Reset value
5:0	TX_BITRATE	I2S transmit bit rate. This value plus one is used to divide TX_MCLK to produce the transmit bit clock.	0
31:6	-	Reserved, user software should not write ones to reserved bits. The value read from a reserved bit is not defined.	-

41.6.12 I2S Receive Clock Bit Rate register

The bit rate for the I2S receiver is determined by the value of the RXBITRATE register. The value depends on the audio sample rate, as well as the data size and format used. The calculation is the same as for TXBITRATE.

Table 922. I2S Receive Clock Rate register (RXBITRATE, address 0x400A 202C (I2S0) and 0x400A 302C (I2S1)) bit description

Bit	Symbol	Description	Reset value
5:0	RX_BITRATE	I2S receive bit rate. This value plus one is used to divide RX_MCLK to produce the receive bit clock.	0
31:6	-	Reserved, user software should not write ones to reserved bits. The value read from a reserved bit is not defined.	-

41.6.13 I2S Transmit Mode Control register

The Transmit Mode Control register contains additional controls for the transmit clock source, enabling the 4-pin mode (SCK and WS signals are shared between I2S transmit and receive blocks), and how MCLK is used.

Table 923. I2S Transmit Mode Control register (TXMODE, address 0x400A 2030 (I2S0) and 0x400A 3030 (I2S1)) bit description

Bit	Symbol	Value	Description	Reset value
1:0	TXCLKSEL		Clock source selection for the transmit bit clock divider.	0
		0x0	Tx fractional rate divider. Select the TX fractional rate divider clock output as the source	
		0x1	Reserved	
		0x2	RX_MCLK. Select the RX_MCLK signal as the TX_MCLK clock source	
		0x3	Reserved	
2	TX4PIN		Transmit 4-pin mode selection (SCK and WS signals are shared between I2S transmit and receive blocks). When 1, enables 4-pin mode.	0
3	TXMCENA		Enable for the TX_MCLK output. When 0, output of TX_MCLK is not enabled. When 1, output of TX_MCLK is enabled.	0
31:4	-		Reserved, user software should not write ones to reserved bits. The value read from a reserved bit is not defined.	NA

41.6.14 I2S Receive Mode Control register

The Receive Mode Control register contains additional controls for receive clock source, enabling the 4-pin mode (SCK and WS signals are shared between I2S transmit and receive blocks), and how MCLK is used.

Table 924. I2S Receive Mode Control register (RXMODE, address 0x400A 2034 (I2S0) and 0x400A 3034 (I2S1)) bit description

Bit	Symbol	Value	Description	Reset value
1:0	RXCLKSEL		Clock source selection for the receive bit clock divider.	0
		0x0	RX fractional divider. Select the RX fractional rate divider clock output as the source	
		0x1	BASE_AUDIO_CLK or I2S_RX_MCLK. Select BASE_AUDIO_CLK or I2S_RX_MCLK as the clock source.	
		0x2	TX_MCLK. Select the TX_MCLK signal as the RX_MCLK clock source	
		0x3	Reserved	
2	RX4PIN		Receive 4-pin mode selection (SCK and WS signals are shared between I2S transmit and receive blocks). When 1, enables 4-pin mode.	0
3	RXMCENA		Enable for the RX_MCLK output. When 0, output of RX_MCLK is not enabled. When 1, output of RX_MCLK is enabled.	0
31:4	-		Reserved, user software should not write ones to reserved bits. The value read from a reserved bit is not defined.	NA

41.7 Functional description

41.7.1 I2S transmit and receive interfaces

The I2S interface can transmit and receive 8-bit, 16-bit or 32-bit stereo or mono audio information. Some details of the I2S implementation are:

- When the transmit FIFO contains insufficient data the transmit channel will repeat transmitting the last data until new data is available. This can occur when the microcontroller or the DMA at some time are unable to provide new data fast enough. Because of this delay in providing new data, there is a need to fill the gap, which is accomplished by continuing to transmit the last sample. The data is not muted, as this would produce a noticeable and undesirable sound effects.
- When mute is true, the data value 0 is transmitted.
- When mono is false, two successive data words are respectively left and right data.
- The transmit channel and the receive channel FIFOs only handle 32-bit aligned segments. Data chunks must be truncated or extended to a multiple of 32 bits. The data word length is determined by the WORDWIDTH value in the configuration register (see [Table 911](#)). There is a separate WORDWIDTH value for the receive channel and the transmit channel. The possible data sequences are as follows:
 - 0: word is considered to contain four 8-bit data words.
 - 1: word is considered to contain two 16-bit data words.
 - 3: word is considered to contain one 32-bit data word.

When switching between different word widths or different modes, the I2S interface must be reset via the reset bit in the control register in order to ensure correct synchronization. It is advisable to set the stop bit also until sufficient data has been written in the transmit FIFO. Note that when stopped, the data output is muted.

Data is read from the transmit FIFO after the falling edge of WS and will be transferred to the transmit clock domain after the rising edge of WS. On the next falling edge of WS, the left data will be loaded in the shift register and transmitted. On the following rising edge of WS, the right data is loaded and transmitted.

The receive channel will start receiving data after a change of WS. When WS becomes low it expects this data to be left data, when WS is high received data is expected to be right data. Reception will stop when the bit counter has reached the limit set by the WORDWIDTH value. On the next change of WS the received data will be stored in the appropriate hold register. When complete data is available, it will be written into the receive FIFO.

41.7.2 I2S operating modes

The clocking and WS usage of the I2S interface is fully configurable. In addition to master and slave modes, which are independently configurable for the transmitter and the receiver, several different clock sources are possible, including variations that share the clock and/or WS between the transmitter and receiver. This last option allows using the I2S interface with fewer pins, typically four.

[Figure 133](#) provides an overview of the complete I2S interface. Specific operating modes are explained in [Section 41.7.2.1](#) and [Section 41.7.2.2](#).

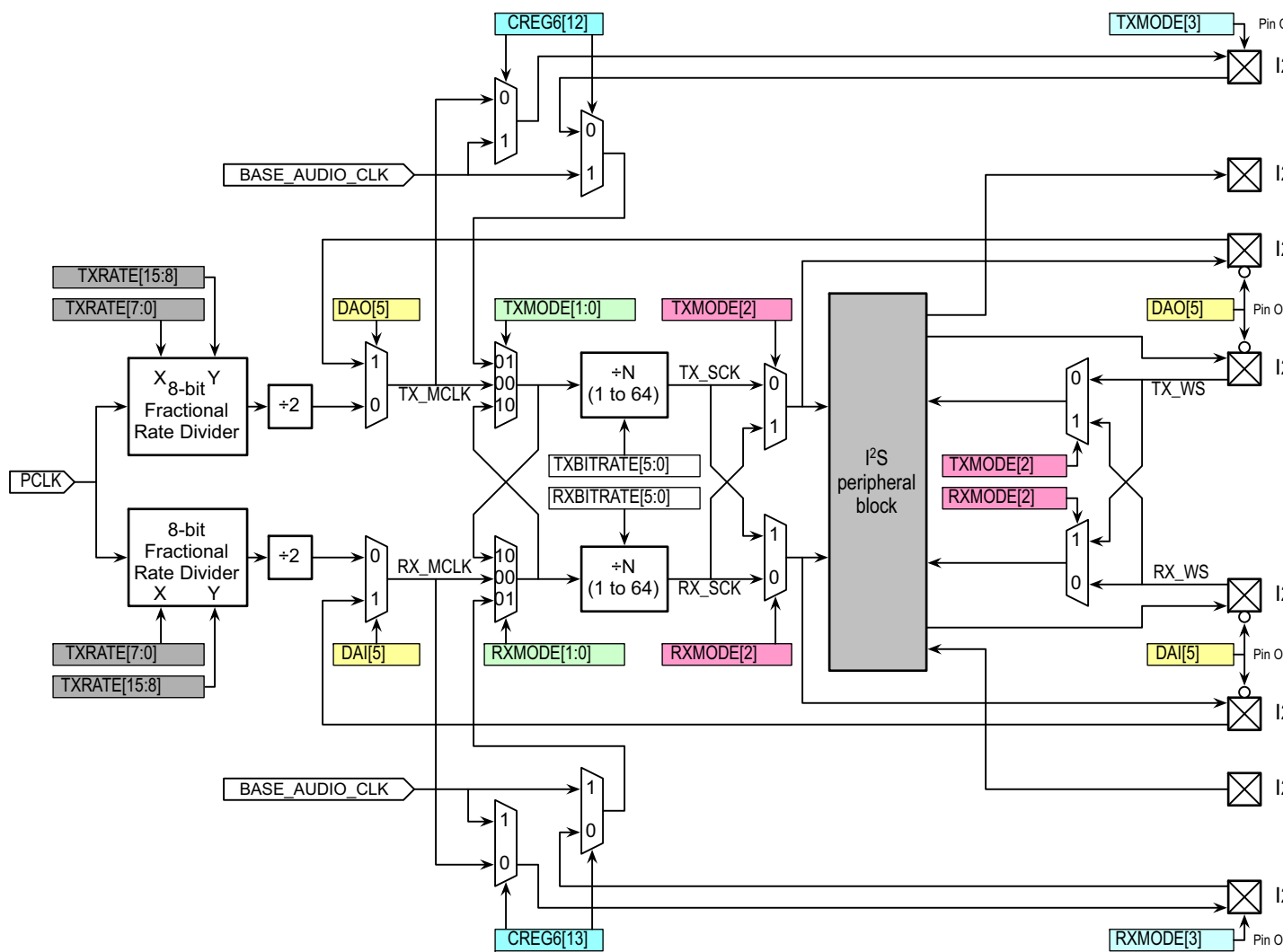

CREG6 bits 12 and 13 select BASE_AUDIO_CLK for the I2S0 interface. CREG bits 14 and 15 select BASE_AUDIO_CLK for the I2S1 interface.

Fig 133. I2S clocking and pin connections

41.7.2.1 I2S Transmitter modes

41.7.2.1.1 Typical transmitter master mode (PCLK - no MCLK output)

Table 925. Typical transmitter master mode (PCLK - no MCLK output)

CREG bit 12	DAO bit 5	TXMODE bits [3:0]	Description
x	0	0 0 0 0	<p>Typical transmitter master mode. See Figure 134.</p> <p>The I2S transmit function operates as a master.</p> <p>The transmit clock source (TX_MCLK) is derived from PCLK using the fractional divider.</p> <p>The WS used is the internally generated TX_WS.</p> <p>The TX_MCLK pin is not enabled for output.</p>

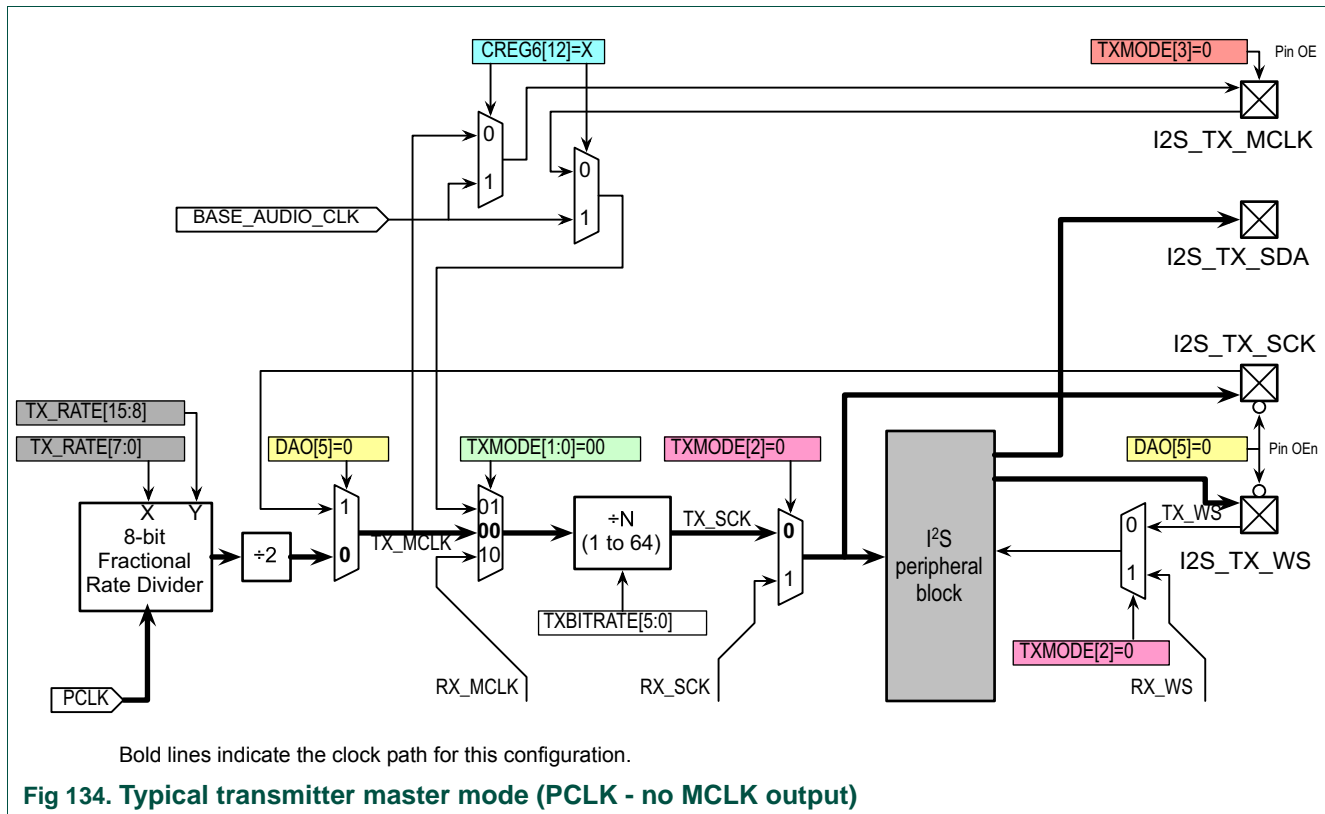

41.7.2.1.2 Transmitter master mode (PCLK), with MCLK output

Table 926. Transmitter master mode (PCLK), with MCLK output

CREG bit 12	DAO bit 5	TXMODE bits [3:0]	Description
0	0	1 0 0 0	Transmitter master mode. The I2S transmit function operates as a master. The transmit clock source (TX_MCLK) is derived from PCLK using the fractional divider. The WS used is the internally generated TX_WS. The TX_MCLK pin is enabled for output.

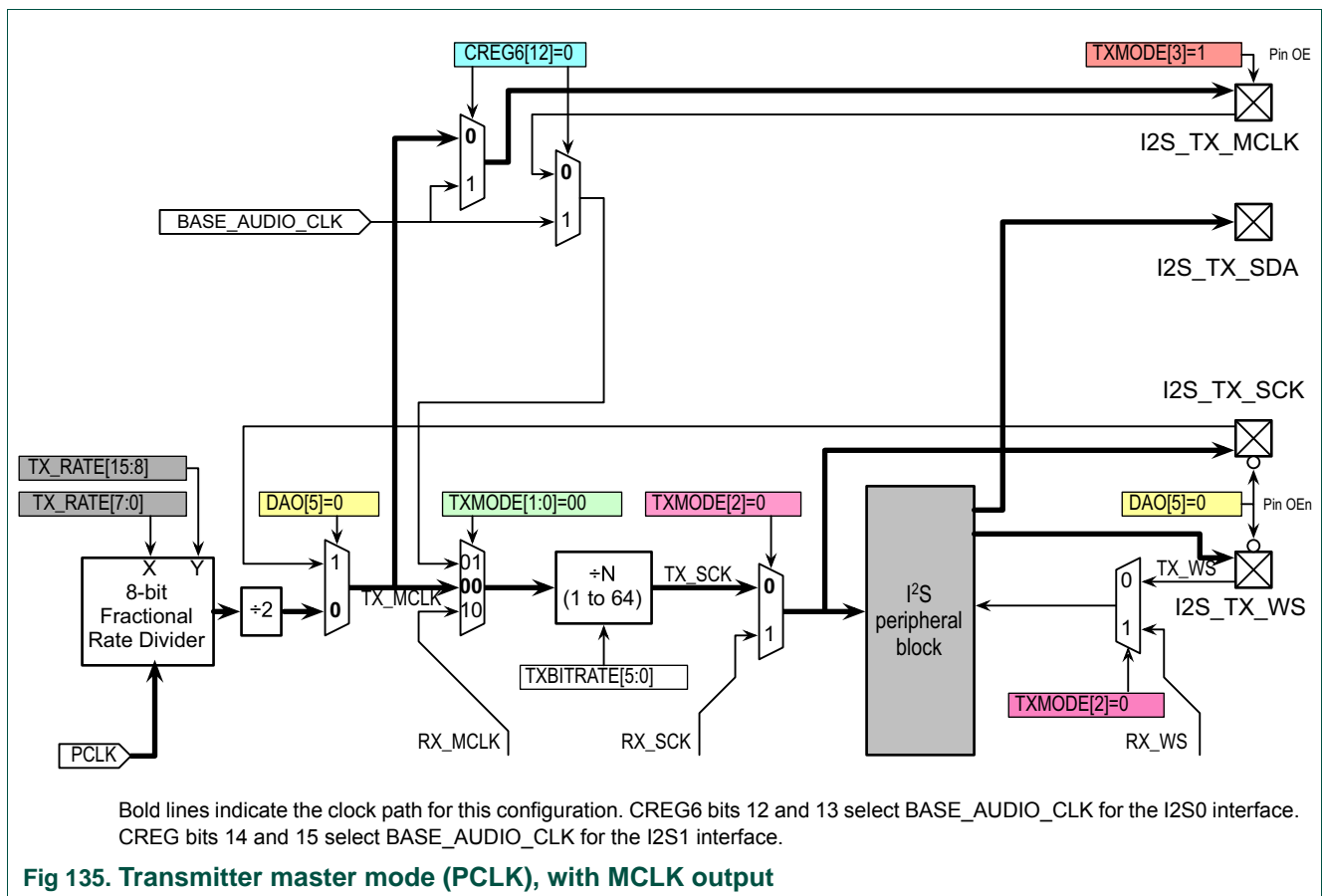

41.7.2.1.3 Transmitter master mode, sharing RX_MCLK

Table 927. Transmitter master mode, sharing RX_MCLK

CREG bit 12	DAO bit 5	TXMODE bits [3:0]	Description
x	0	0 0 1 0	Transmitter master mode sharing the receiver reference clock (RX_MCLK). The I2S transmit function operates as a master. The transmit clock source is RX_MCLK. The WS used is the internally generated TX_WS. The TX_MCLK pin is not enabled for output.

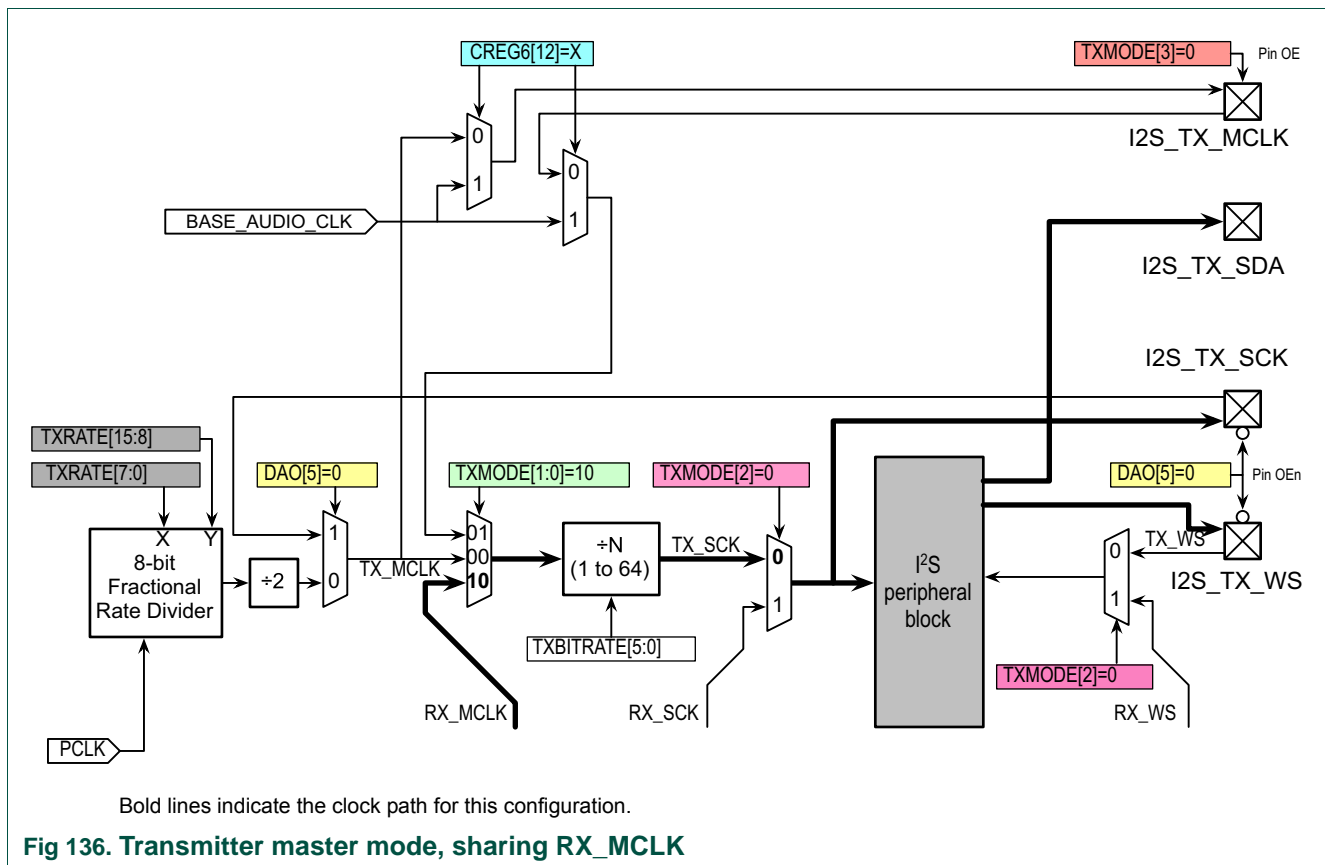

41.7.2.1.4 Typical Transmitter slave mode

Table 928. Typical Transmitter slave mode

CREG bit 12	DAO bit 5	TXMODE bits [3:0]	Description
x	1	0 0 0 0	<p>Typical transmitter slave mode.</p> <p>The I2S transmit function operates as a slave.</p> <p>The transmit clock source TX_SCK is provided by the external master on the TX_SCK pin. The transmit bit rate divider must be set to 1 (TXBITRATE[5:0]=000000) for this mode to operate correctly.</p> <p>The WS signal is provided by the external master on the TX_WS pin.</p>

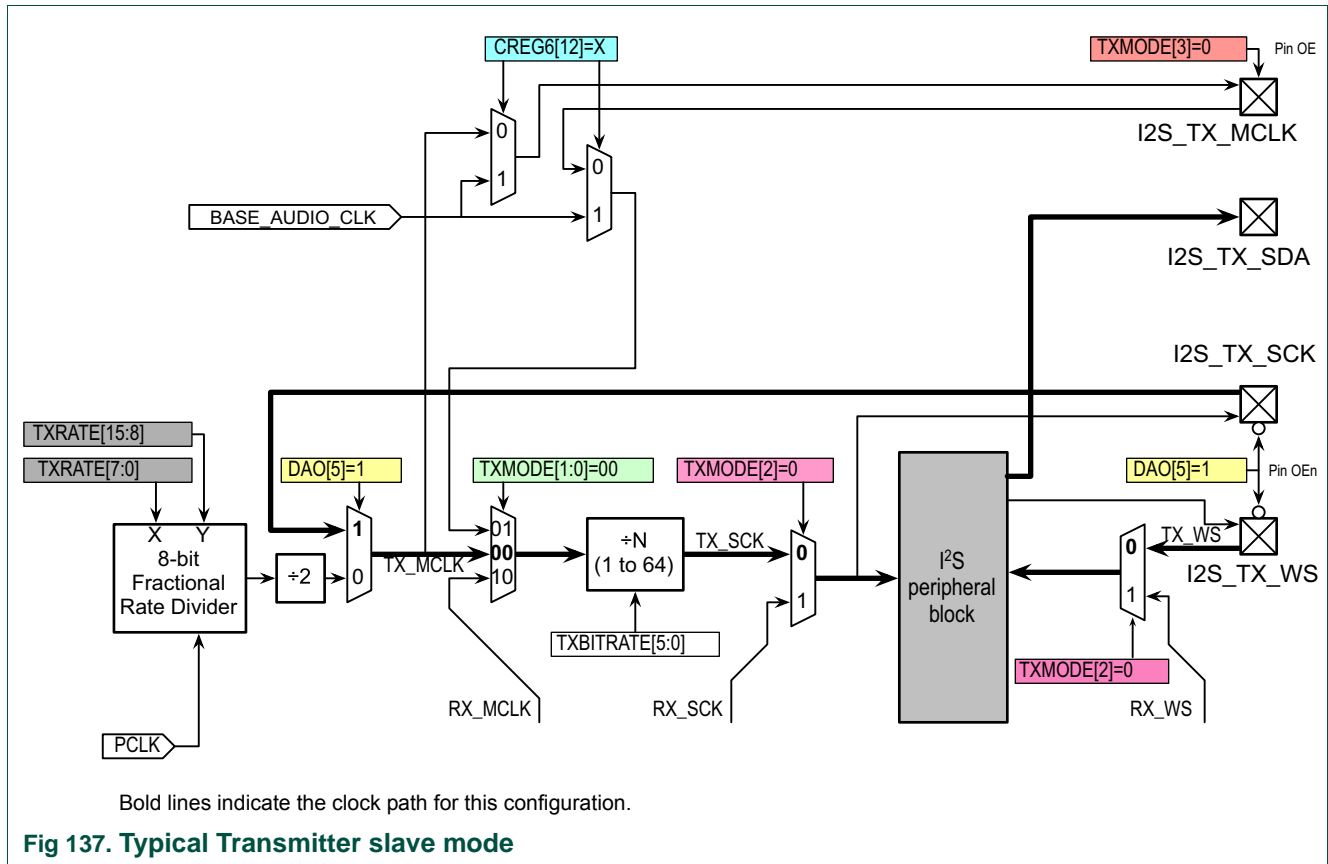

41.7.2.1.6 Transmitter master mode (BASE_AUDIO_CLK)

Table 930. Transmitter master mode (BASE_AUDIO_CLK)

CREG bit 12	DAO bit 5	TXMODE bits [3:0]	Description
1	0	1 0 0 1	Transmitter master mode. The I2S transmit function operates as a master. The transmit clock source (TX_MCLK) is derived from the BASE_AUDIO_CLK The WS used is the internally generated TX_WS. The TX_MCLK pin is enabled for output.

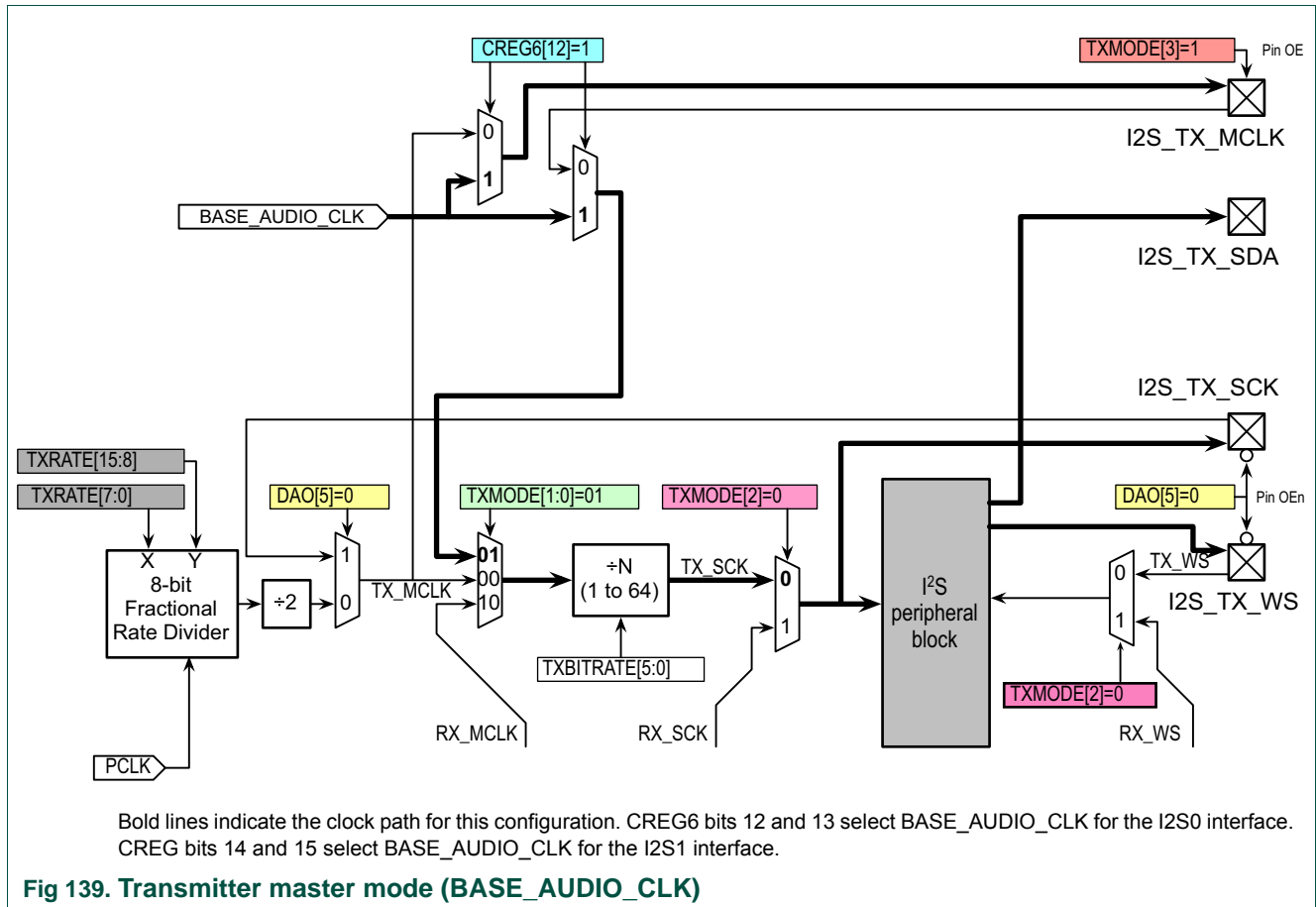

41.7.2.1.7 Transmitter master mode (External MCLK)

Table 931. Transmitter master mode (External MCLK)

CREG bit 12	DAO bit 5	TXMODE bits [3:0]	Description
0	0	0 0 0 1	<p>Transmitter master mode.</p> <p>The I2S transmit function operates as a master.</p> <p>The transmit clock source (TX_MCLK) is provided by the external master on the TX_MCLK pin.</p> <p>The WS used is the internally generated TX_WS.</p> <p>The TX_MCLK pin is enabled for input.</p>

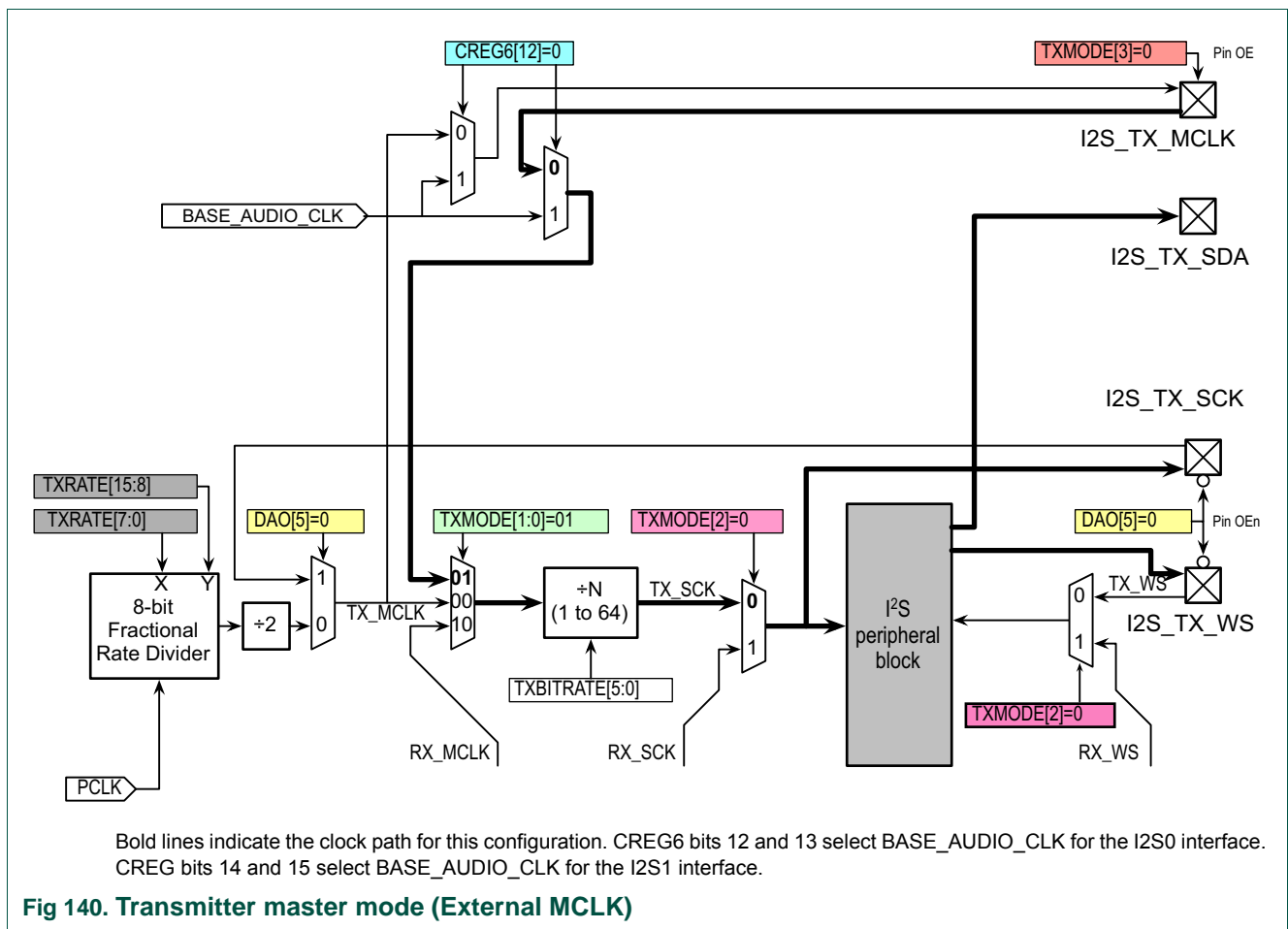

41.7.2.2 I2S Receiver modes

41.7.2.2.1 Typical Receiver master mode (PCLK - no MCLK output)

Table 932. Typical Receiver master mode (PCLK - no MCLK output)

CREG bit 13	DAI bit 5	RXMODE bits [3:0]	Description
x	0	0 0 0 0	<p>Typical receiver master mode.</p> <p>The I2S receive function operates as a master.</p> <p>The receive clock source (RX_MCLK) is derived from PCLK using the fractional divider.</p> <p>The WS used is the internally generated RX_WS.</p> <p>The RX_MCLK pin is not enabled for output.</p>

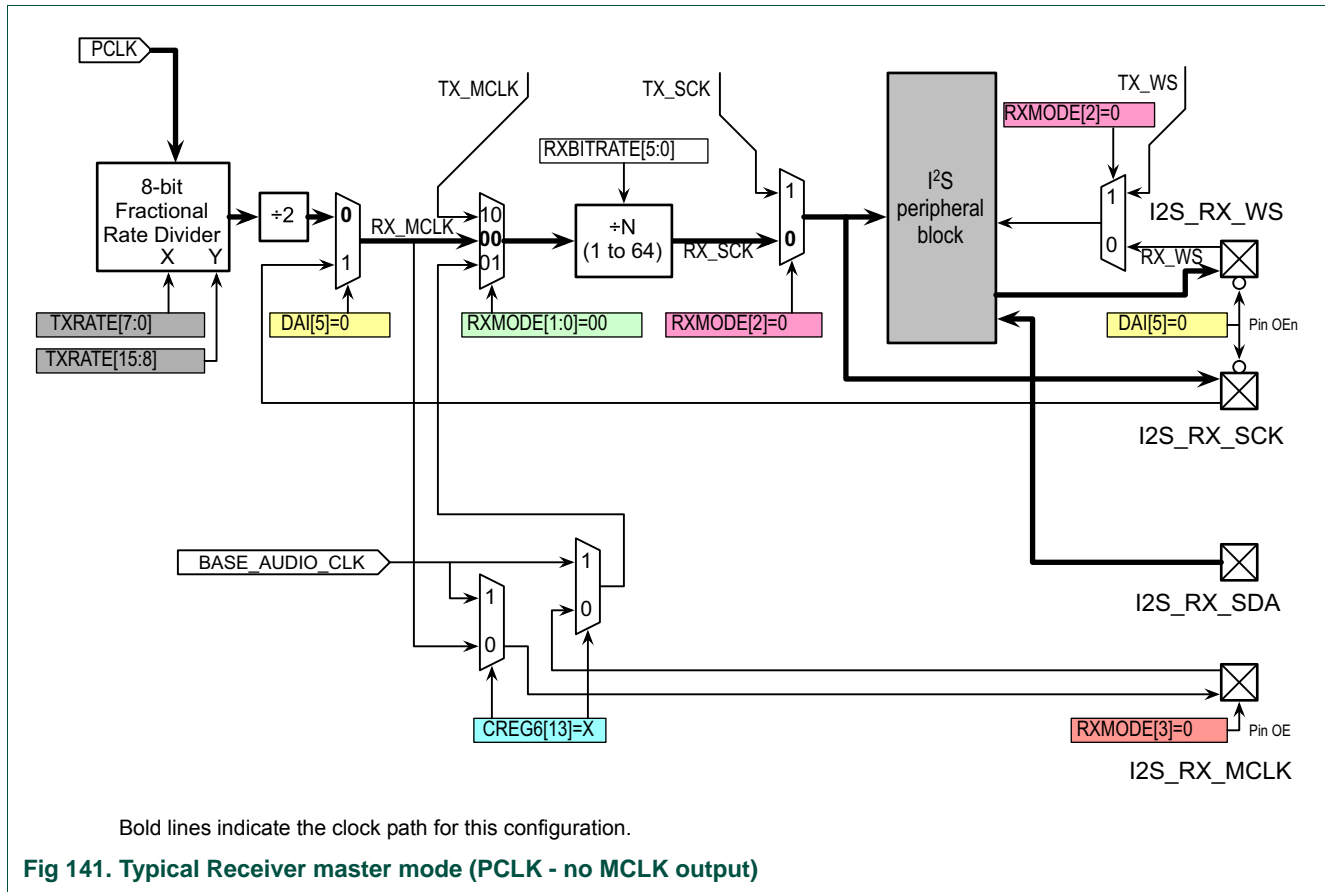

41.7.2.2.2 Receiver master mode (PCLK), with MCLK output

Table 933. Receiver master mode (PCLK), with MCLK output

CREG bit 13	DAI bit 5	RXMODE bits [3:0]	Description
0	0	1 0 0 0	Receiver master mode. The I2S receive function operates as a master. The receive clock source (RX_MCLK) is derived from PCLK using the fractional divider. The WS used is the internally generated RX_WS. The RX_MCLK pin is enabled for output.

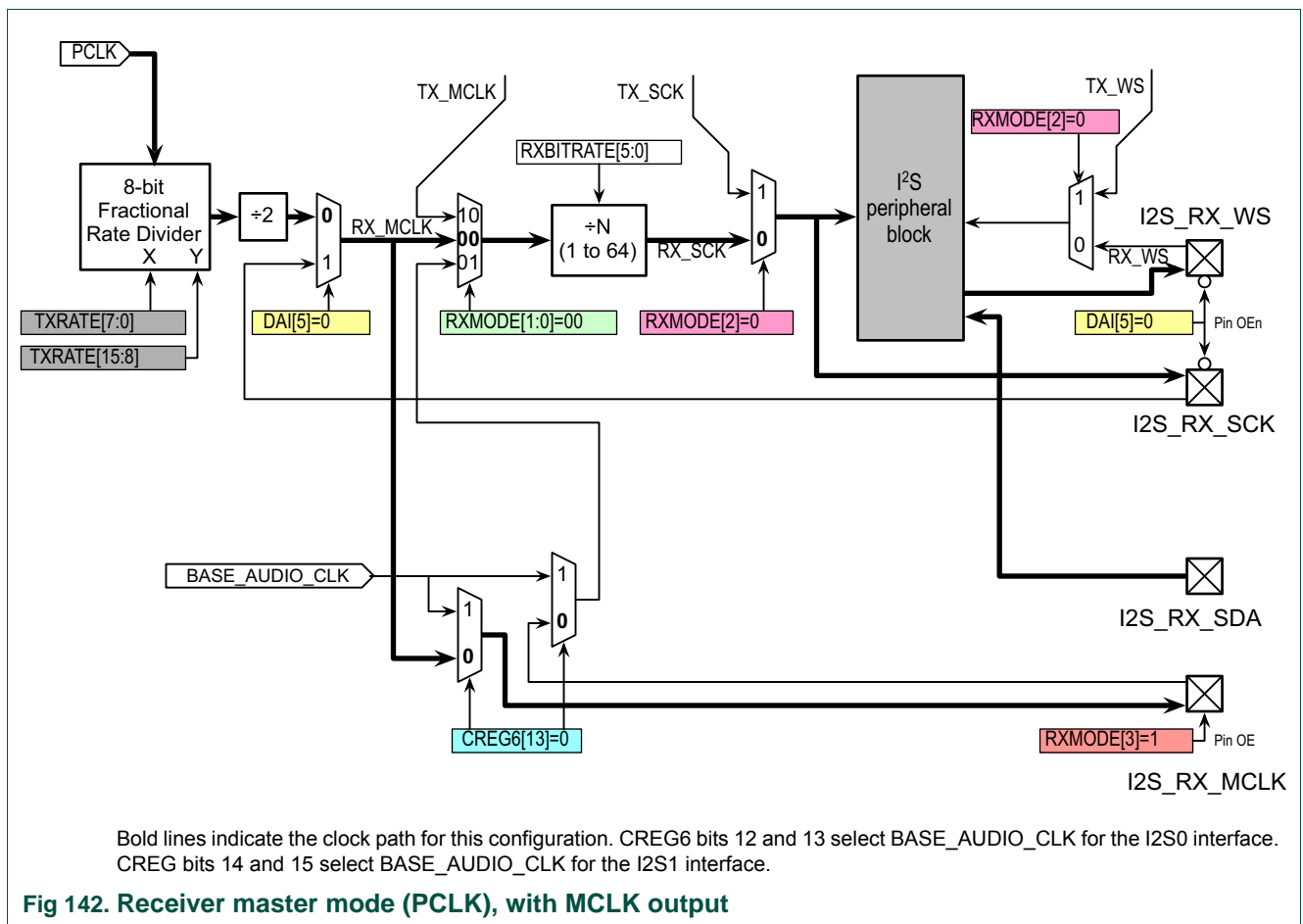

41.7.2.2.3 Receiver master mode, sharing TX_MCLK

Table 934. Receiver master mode, sharing TX_MCLK

CREG bit 13	DAI bit 5	RXMODE bits [3:0]	Description
x	0	0 0 1 0	Receiver master mode sharing the transmitter reference clock (TX_MCLK). The I2S receive function operates as a master. The receive clock source is TX_MCLK. The WS used is the internally generated RX_WS. The RX_MCLK pin is not enabled for output.

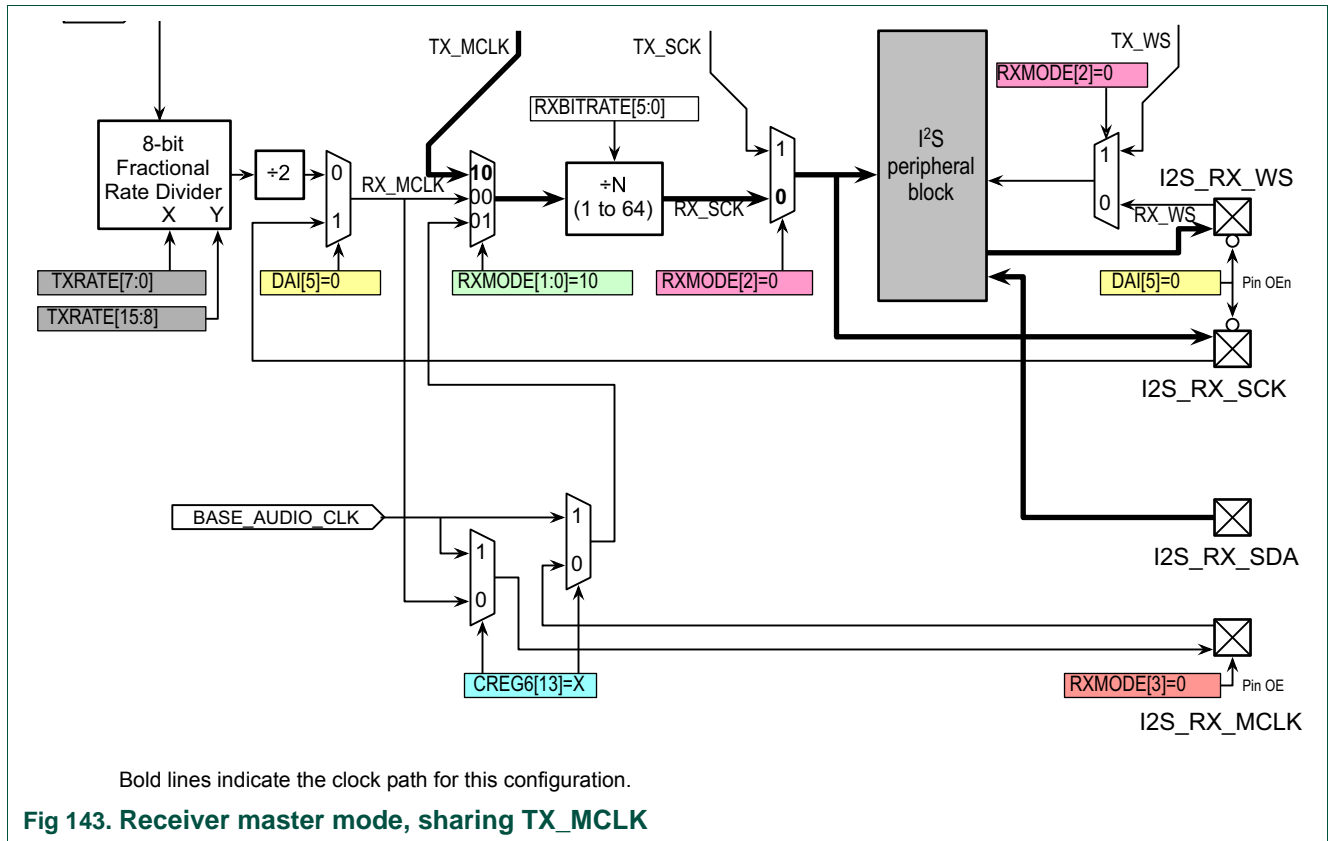

41.7.2.2.4 Typical Receiver slave mode

Table 935. Typical Receiver slave mode

CREG bit 13	DAI bit 5	RXMODE bits [3:0]	Description
x	1	0 0 0 0	<p>Typical receiver slave mode.</p> <p>The I2S receive function operates as a slave.</p> <p>The receive clock source RX_SCK is provided by the external master on the RX_SCK pin. The receive bit rate divider must be set to 1 (RXBITRATE[5:0]=000000) for this mode to operate correctly.</p> <p>The WS signal is provided by the external master on the RX_WS pin.</p>

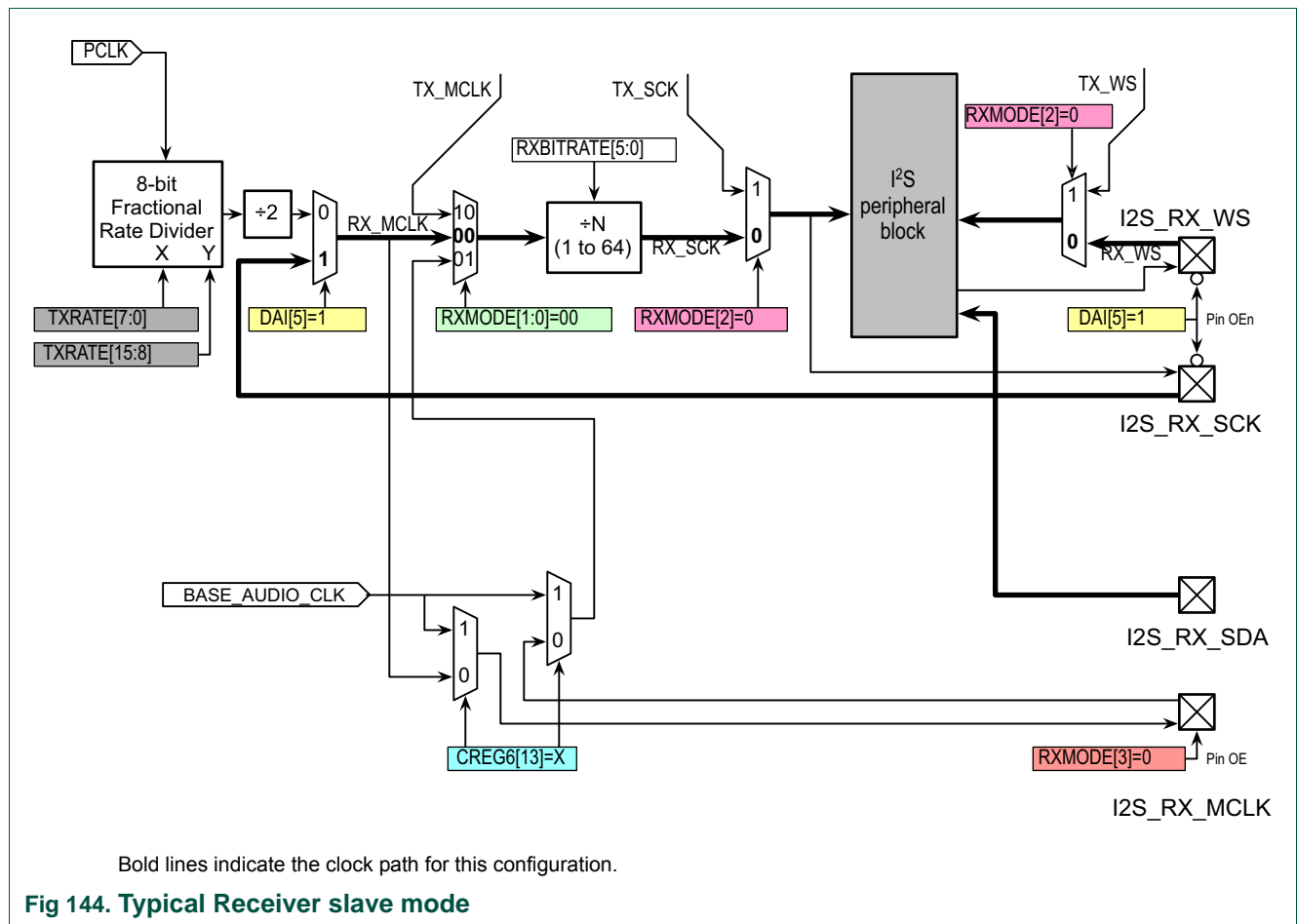

Bold lines indicate the clock path for this configuration.

41.7.2.2.5 4-Wire Receiver mode

Table 936. 4-Wire Receiver mode

CREG bit 13	DAI bit 5	RXMODE bits [3:0]	Description
x	1	0 1 x x	<p>4-wire receiver mode sharing the transmitter TX_SCK and TX_WS (4-pin mode). The I2S receive function operates as an internal slave to the transmit function. The transmit function can operate in either master or slave mode, determining the operating mode of the entire I2S interface.</p> <p>The receive clock source is TX_SCK.</p> <p>The WS used is the internally generated TX_WS.</p> <p>The RX_MCLK pin is not enabled for output.</p>

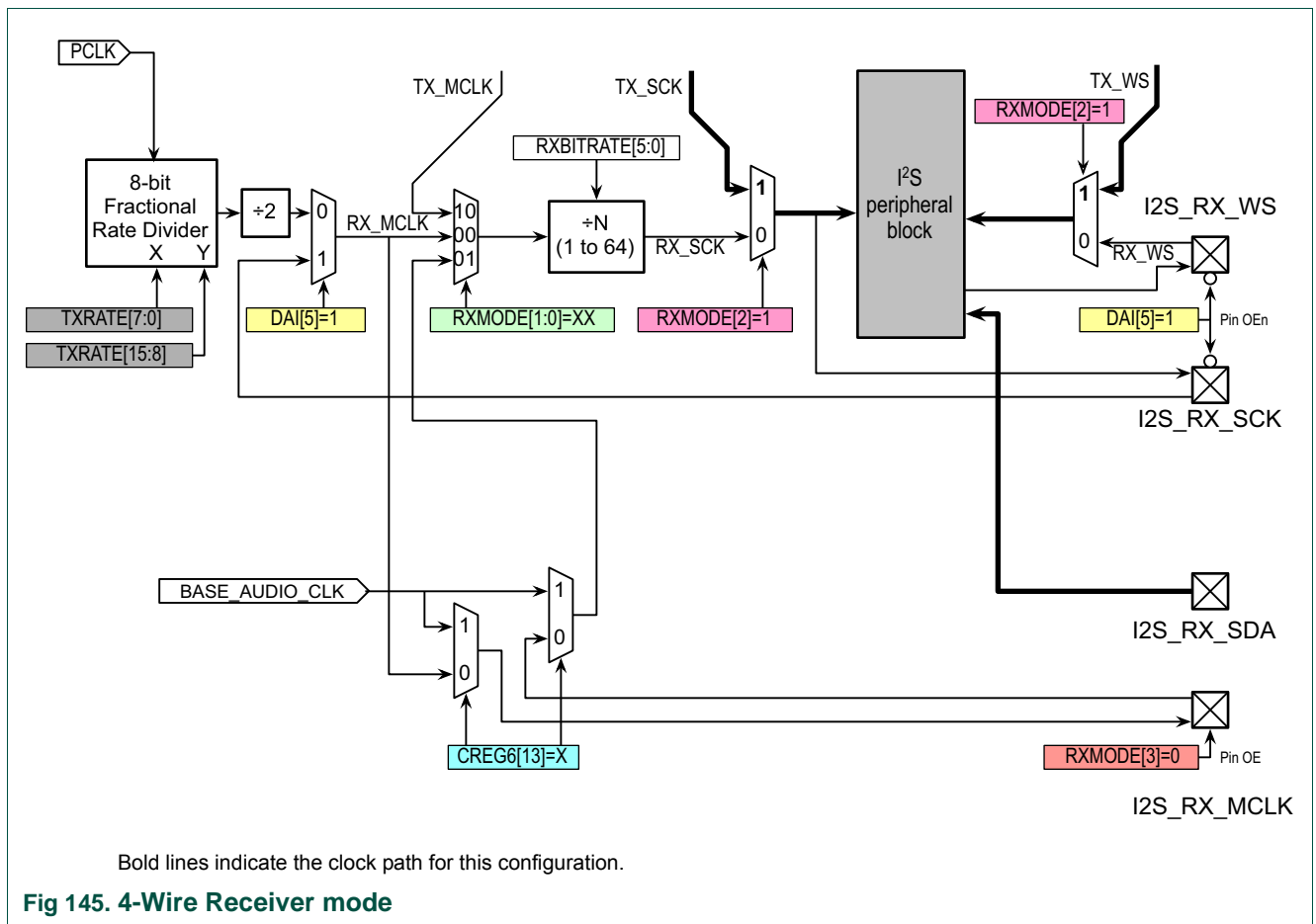

Bold lines indicate the clock path for this configuration.

41.7.2.2.7 Receiver master mode (External MCLK)

Table 938. Receiver master mode (External MCLK)

CREG bit 13	DAI bit 5	RXMODE bits [3:0]	Description
0	0	0001	Receiver master mode. The I2S receive function operates as a master. The receive clock source (RX_MCLK) is provided by the external master on the RX_MCLK pin. The WS used is the internally generated RX_WS. The RX_MCLK pin is enabled for input.

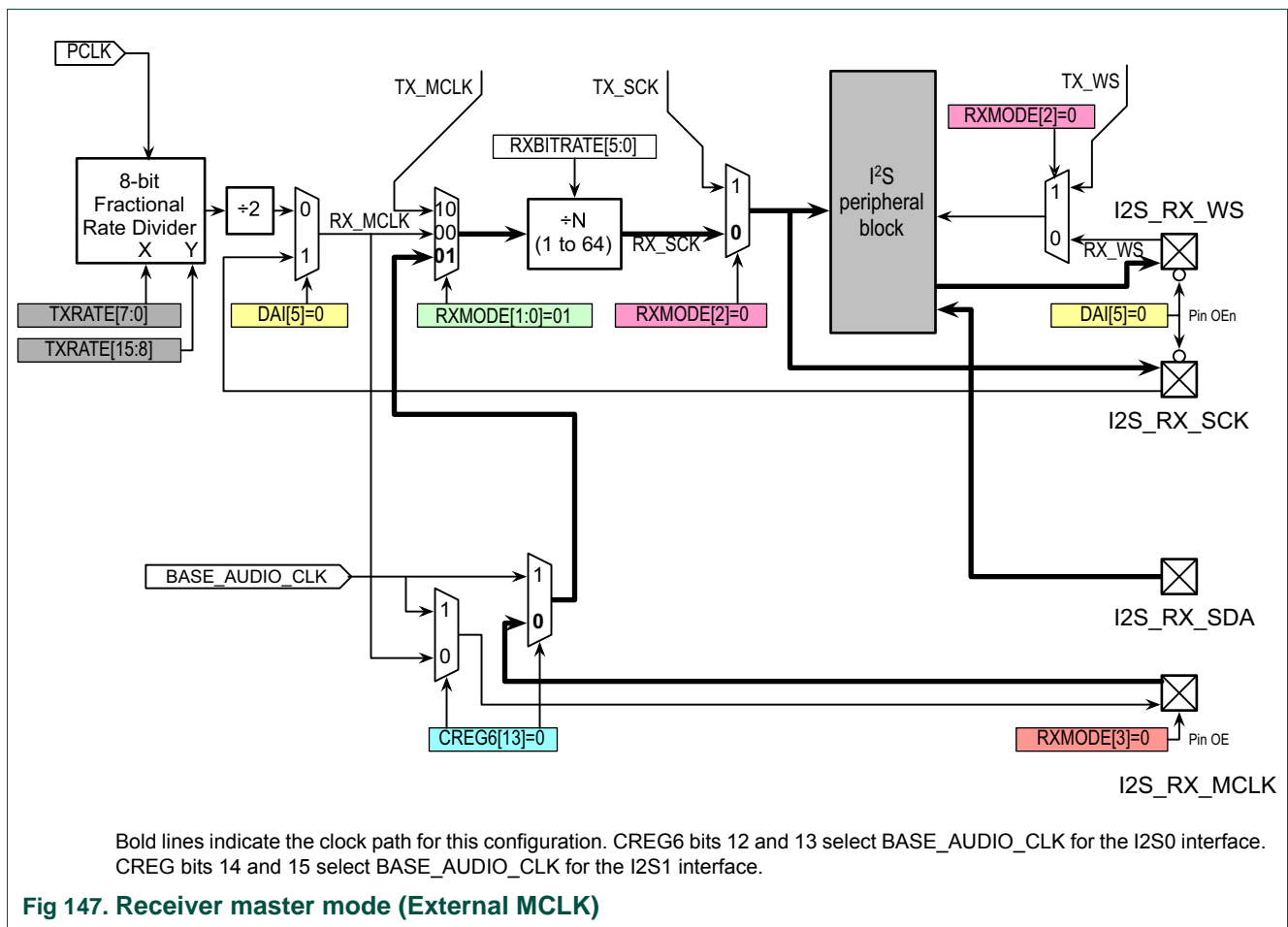

41.7.3 FIFO controller

Handling of data for transmission and reception is performed via the FIFO controller which can generate two DMA requests and an interrupt request. The controller consists of a set of comparators which compare FIFO levels with depth settings contained in registers. The current status of the level comparators can be seen in the APB status register.

Table 939. Conditions for FIFO level comparison

Level Comparison	Condition
dmareq_tx_1	tx_depth_dma1 >= tx_level
dmareq_rx_1	rx_depth_dma1 <= rx_level
dmareq_tx_2	tx_depth_dma2 >= tx_level
dmareq_rx_2	rx_depth_dma2 <= rx_level
irq_tx	tx_depth_irq >= tx_level
irq_rx	rx_depth_irq <= rx_level

System signaling occurs when a level detection is true and enabled.

Table 940. DMA and interrupt request generation

System Signaling	Condition
irq	(irq_rx & rx_irq_enable) (irq_tx & tx_irq_enable)
dmareq[0]	(dmareq_tx_1 & tx_dma1_enable) (dmareq_rx_1 & rx_dma1_enable)
dmareq[1]	(dmareq_tx_2 & tx_dma2_enable) (dmareq_rx_2 & rx_dma2_enable)

Table 941. Status feedback in the STATE register

Status Feedback	Status
irq	irq_rx irq_tx
dmareq1	(dmareq_tx_1 dmareq_rx_1)
dmareq2	(dmareq_rx_2 dmareq_tx_2)

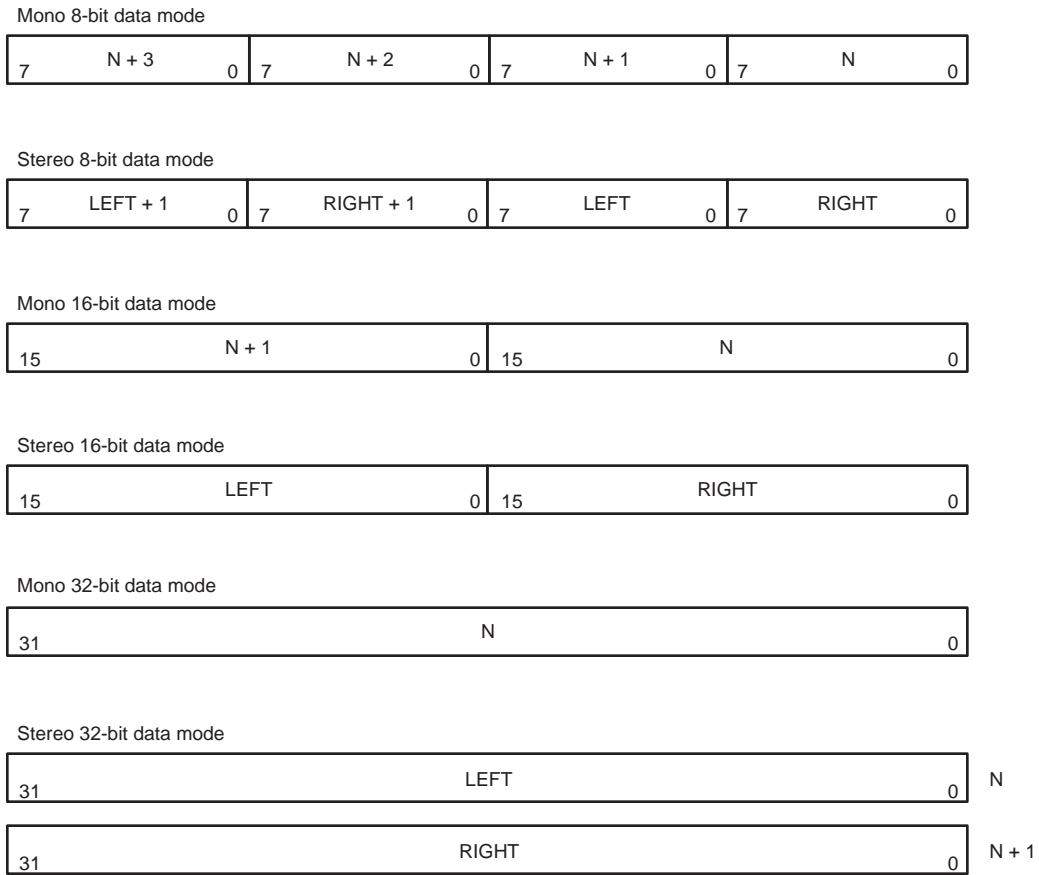

Fig 148. FIFO contents for various I2S modes

42.1 How to read this chapter

The I2C-bus interfaces I2C0 and I2C1 are available on all LPC18xx parts.

42.2 Basic configuration

The I2C0/1 are configured as follows:

- See [Table 942](#) for clocking and power control.
- The I2C0/1 are reset by the I2C0/1_RST (reset # 48/49).
- The I2C0/1 interrupts are connected to slots # 18/19 in the NVIC.
- Configure the I2C0 pins for Fast-mode Plus, Fast mode, or Standard mode through the SFSI2C0 register in the SYSCON block (see [Table 178](#)).

Table 942. I2C0/1 clocking and power control

	Base clock	Branch clock	Operating frequency
Clock to the I2C0 register interface and I2C0 peripheral clock.	BASE_APB1_CLK	CLK_APB1_I2C0	up to 180 MHz
Clock to the I2C1 register interface and I2C1 peripheral clock.	BASE_APB3_CLK	CLK_APB3_I2C1	up to 180 MHz

42.3 Features

- The I2C0-bus interface uses true open-drain pins and supports Fast mode plus with bit rates of up to 1Mbit/s, Fast mode, or Standard mode.
- The I2C1-bus interface uses standard port pins supporting bit rates of up to 400 kbit/s.
- Standard I²C-compliant bus interfaces may be configured as Master, Slave, or Master/Slave.
- Arbitration is handled between simultaneously transmitting masters without corruption of serial data on the bus.
- Programmable clock allows adjustment of I²C transfer rates.
- Data transfer is bidirectional between masters and slaves.
- Serial clock synchronization allows devices with different bit rates to communicate via one serial bus.
- Serial clock synchronization is used as a handshake mechanism to suspend and resume serial transfer.
- Optional recognition of up to four distinct slave addresses.
- Monitor mode allows observing all I²C-bus traffic, regardless of slave address.
- I²C-bus can be used for test and diagnostic purposes.
- The I²C-bus contains a standard I²C-compliant bus interface with two pins.

42.4 Applications

Interfaces to external I²C standard parts, such as serial RAMs, LCDs, tone generators, other microcontrollers, etc.

42.5 General description

A typical I²C-bus configuration is shown in [Figure 149](#). Depending on the state of the direction bit (R/W), two types of data transfers are possible on the I²C-bus:

- Data transfer from a master transmitter to a slave receiver. The first byte transmitted by the master is the slave address. Next follows a number of data bytes. The slave returns an acknowledge bit after each received byte.
- Data transfer from a slave transmitter to a master receiver. The first byte (the slave address) is transmitted by the master. The slave then returns an acknowledge bit. Next follows the data bytes transmitted by the slave to the master. The master returns an acknowledge bit after all received bytes other than the last byte. At the end of the last received byte, a “not acknowledge” is returned. The master device generates all of the serial clock pulses and the START and STOP conditions. A transfer is ended with a STOP condition or with a Repeated START condition. Since a Repeated START condition is also the beginning of the next serial transfer, the I²C bus will not be released.

The I²C interface is byte oriented and has four operating modes: master transmitter mode, master receiver mode, slave transmitter mode and slave receiver mode.

The I²C interface complies with the entire I²C specification, supporting the ability to turn power off to the processor without interfering with other devices on the same I²C-bus.

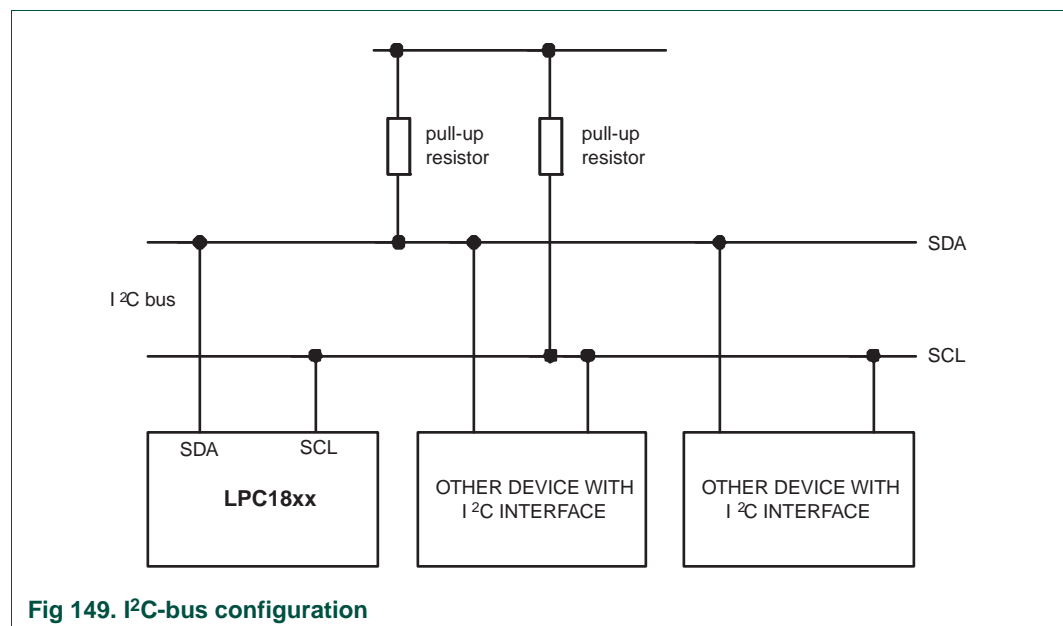

Fig 149. I²C-bus configuration

42.5.1 I²C Fast-mode Plus

Fast-Mode Plus supports a 1 Mbit/sec transfer rate to communicate with the I²C-bus products which NXP Semiconductors is now providing.

In order to use Fast-Mode Plus, the I²C pins must be properly configured in the SFSI2C0 register in the SYSCON block (see [Table 178](#)).

42.6 Pin description

Table 943. I²C-bus pin description

Pin function	Type	Description
I2C0_SDA	Input/Output	I ² C data input/output. Open-drain output (for I ² C-bus compliance).
I2C0_SCL	Input/Output	I ² C clock input/output. Open-drain output (for I ² C-bus compliance).
I2C1_SDA	Input/Output	I ² C Serial Data. Uses standard I/O pins (Fast-mode only).
I2C1_SCL	Input/Output	I ² C Serial Clock. Uses standard I/O pins (Fast-mode only).

The I²C-bus pins must be configured through SYSCON registers for Standard/ Fast-mode or Fast-mode Plus.

42.7 Register description

Table 944. Register overview: I²C0 (base address 0x400A 1000)

Name	Access	Address offset	Description	Reset value ^[1]	Reference
CONSET	R/W	0x000	I2C Control Set Register. When a one is written to a bit of this register, the corresponding bit in the I ² C control register is set. Writing a zero has no effect on the corresponding bit in the I ² C control register.	0x00	Table 946
STAT	RO	0x004	I2C Status Register. During I ² C operation, this register provides detailed status codes that allow software to determine the next action needed.	0xF8	Table 947
DAT	R/W	0x008	I2C Data Register. During master or slave transmit mode, data to be transmitted is written to this register. During master or slave receive mode, data that has been received may be read from this register.	0x00	Table 948
ADR0	R/W	0x00C	I2C Slave Address Register 0. Contains the 7-bit slave address for operation of the I ² C interface in slave mode, and is not used in master mode. The least significant bit determines whether a slave responds to the General Call address.	0x00	Table 949
SCLH	R/W	0x010	SCH Duty Cycle Register High Half Word. Determines the high time of the I ² C clock.	0x04	Table 950
SCLL	R/W	0x014	SCL Duty Cycle Register Low Half Word. Determines the low time of the I ² C clock. SCLL and SCLH together determine the clock frequency generated by an I ² C master and certain times used in slave mode.	0x04	Table 951

Table 944. Register overview: I²C0 (base address 0x400A 1000) ...continued

Name	Access	Address offset	Description	Reset value ^[1]	Reference
CONCLR	WO	0x018	I2C Control Clear Register. When a one is written to a bit of this register, the corresponding bit in the I ² C control register is cleared. Writing a zero has no effect on the corresponding bit in the I ² C control register.	-	Table 953
MMCTRL	R/W	0x01C	Monitor mode control register.	0x00	Table 954
ADR1	R/W	0x020	I2C Slave Address Register 1. Contains the 7-bit slave address for operation of the I ² C interface in slave mode, and is not used in master mode. The least significant bit determines whether a slave responds to the General Call address.	0x00	Table 955
ADR2	R/W	0x024	I2C Slave Address Register 2. Contains the 7-bit slave address for operation of the I ² C interface in slave mode, and is not used in master mode. The least significant bit determines whether a slave responds to the General Call address.	0x00	Table 955
ADR3	R/W	0x028	I2C Slave Address Register 3. Contains the 7-bit slave address for operation of the I ² C interface in slave mode, and is not used in master mode. The least significant bit determines whether a slave responds to the General Call address.	0x00	Table 955
DATA_BUFFER	RO	0x02C	Data buffer register. The contents of the 8 MSBs of the DAT shift register will be transferred to the DATA_BUFFER automatically after every nine bits (8 bits of data plus ACK or NACK) has been received on the bus.	0x00	Table 956
MASK0	R/W	0x030	I2C Slave address mask register 0. This mask register is associated with ADR0 to determine an address match. The mask register has no effect when comparing to the General Call address ('0000000').	0x00	Table 957
MASK1	R/W	0x034	I2C Slave address mask register 1. This mask register is associated with ADR1 to determine an address match. The mask register has no effect when comparing to the General Call address ('0000000').	0x00	Table 957
MASK2	R/W	0x038	I2C Slave address mask register 2. This mask register is associated with ADR2 to determine an address match. The mask register has no effect when comparing to the General Call address ('0000000').	0x00	Table 957
MASK3	R/W	0x03C	I2C Slave address mask register 3. This mask register is associated with ADR3 to determine an address match. The mask register has no effect when comparing to the General Call address ('0000000').	0x00	Table 957

[1] Reset value reflects the data stored in used bits only. It does not include reserved bits content.

Table 945. Register overview: I²C1 (base address 0x400E 0000)

Name	Access	Address offset	Description	Reset value ^[1]	Reference
CONSET	R/W	0x000	I2C Control Set Register. When a one is written to a bit of this register, the corresponding bit in the I ² C control register is set. Writing a zero has no effect on the corresponding bit in the I ² C control register.	0x00	Table 946
STAT	RO	0x004	I2C Status Register. During I ² C operation, this register provides detailed status codes that allow software to determine the next action needed.	0xF8	Table 947
IDAT	R/W	0x008	I2C Data Register. During master or slave transmit mode, data to be transmitted is written to this register. During master or slave receive mode, data that has been received may be read from this register.	0x00	Table 948
ADR0	R/W	0x00C	I2C Slave Address Register 0. Contains the 7-bit slave address for operation of the I ² C interface in slave mode, and is not used in master mode. The least significant bit determines whether a slave responds to the General Call address.	0x00	Table 949
SCLH	R/W	0x010	SCH Duty Cycle Register High Half Word. Determines the high time of the I ² C clock.	0x04	Table 950
SCLL	R/W	0x014	SCL Duty Cycle Register Low Half Word. Determines the low time of the I ² C clock. SCLL and SCLH together determine the clock frequency generated by an I ² C master and certain times used in slave mode.	0x04	Table 951
CONCLR	WO	0x018	I2C Control Clear Register. When a one is written to a bit of this register, the corresponding bit in the I ² C control register is cleared. Writing a zero has no effect on the corresponding bit in the I ² C control register.	-	Table 953
MMCTRL	R/W	0x01C	Monitor mode control register.	0x00	Table 954
ADR1	R/W	0x020	I2C Slave Address Register 1. Contains the 7-bit slave address for operation of the I ² C interface in slave mode, and is not used in master mode. The least significant bit determines whether a slave responds to the General Call address.	0x00	Table 955
ADR2	R/W	0x024	I2C Slave Address Register 2. Contains the 7-bit slave address for operation of the I ² C interface in slave mode, and is not used in master mode. The least significant bit determines whether a slave responds to the General Call address.	0x00	Table 955
ADR3	R/W	0x028	I2C Slave Address Register 3. Contains the 7-bit slave address for operation of the I ² C interface in slave mode, and is not used in master mode. The least significant bit determines whether a slave responds to the General Call address.	0x00	Table 955
DATA_BUFFER	RO	0x02C	Data buffer register. The contents of the 8 MSBs of the DAT shift register will be transferred to the DATA_BUFFER automatically after every nine bits (8 bits of data plus ACK or NACK) has been received on the bus.	0x00	Table 956
MASK0	R/W	0x030	I2C Slave address mask register 0. This mask register is associated with ADR0 to determine an address match. The mask register has no effect when comparing to the General Call address ('0000000').	0x00	Table 957

Table 945. Register overview: I²C1 (base address 0x400E 0000) ...continued

Name	Access	Address offset	Description	Reset value ^[1]	Reference
MASK1	R/W	0x034	I²C Slave address mask register 1. This mask register is associated with ADR1 to determine an address match. The mask register has no effect when comparing to the General Call address ('0000000').	0x00	Table 957
MASK2	R/W	0x038	I²C Slave address mask register 2. This mask register is associated with ADR2 to determine an address match. The mask register has no effect when comparing to the General Call address ('0000000').	0x00	Table 957
MASK3	R/W	0x03C	I²C Slave address mask register 3. This mask register is associated with ADR3 to determine an address match. The mask register has no effect when comparing to the General Call address ('0000000').	0x00	Table 957

[1] Reset value reflects the data stored in used bits only. It does not include reserved bits content.

42.7.1 I²C Control Set register

The CONSET registers control setting of bits in the CON register that controls operation of the I²C interface. Writing a one to a bit of this register causes the corresponding bit in the I²C control register to be set. Writing a zero has no effect.

Table 946. I²C Control Set register (CONSET - address 0x400A 1000 (I2C0) and 0x400E 0000 (I2C1)) bit description

Bit	Symbol	Description	Reset value
1:0	-	Reserved. User software should not write ones to reserved bits. The value read from a reserved bit is not defined.	-
2	AA	Assert acknowledge flag.	
3	SI	I ² C interrupt flag.	0
4	STO	STOP flag.	0
5	STA	START flag.	0
6	I2EN	I ² C interface enable.	0
31:7	-	Reserved. The value read from a reserved bit is not defined.	-

I2EN I²C Interface Enable. When I2EN is 1, the I²C interface is enabled. I2EN can be cleared by writing 1 to the I2ENC bit in the CONCLR register. When I2EN is 0, the I²C interface is disabled.

When I2EN is "0", the SDA and SCL input signals are ignored, the I²C block is in the "not addressed" slave state, and the STO bit is forced to "0".

I2EN should not be used to temporarily release the I²C-bus since, when I2EN is reset, the I²C-bus status is lost. The AA flag should be used instead.

STA is the START flag. Setting this bit causes the I²C interface to enter master mode and transmit a START condition or transmit a Repeated START condition if it is already in master mode.

When STA is 1 and the I²C interface is not already in master mode, it enters master mode, checks the bus and generates a START condition if the bus is free. If the bus is not free, it waits for a STOP condition (which will free the bus) and generates a START condition after a delay of a half clock period of the internal clock generator. If the I²C interface is already in master mode and data has been transmitted or received, it transmits a Repeated START condition. STA may be set at any time, including when the I²C interface is in an addressed slave mode.

STA can be cleared by writing 1 to the STAC bit in the CONCLR register. When STA is 0, no START condition or Repeated START condition will be generated.

If STA and STO are both set, then a STOP condition is transmitted on the I²C-bus if it the interface is in master mode, and transmits a START condition thereafter. If the I²C interface is in slave mode, an internal STOP condition is generated, but is not transmitted on the bus.

STO is the STOP flag. Setting this bit causes the I²C interface to transmit a STOP condition in master mode, or recover from an error condition in slave mode. When STO is 1 in master mode, a STOP condition is transmitted on the I²C-bus. When the bus detects the STOP condition, STO is cleared automatically.

In slave mode, setting this bit can recover from an error condition. In this case, no STOP condition is transmitted to the bus. The hardware behaves as if a STOP condition has been received and it switches to “not addressed” slave receiver mode. The STO flag is cleared by hardware automatically.

SI is the I²C Interrupt Flag. This bit is set when the I²C state changes. However, entering state F8 does not set SI since there is nothing for an interrupt service routine to do in that case.

While SI is set, the low period of the serial clock on the SCL line is stretched, and the serial transfer is suspended. When SCL is HIGH, it is unaffected by the state of the SI flag. SI must be reset by software, by writing a 1 to the SIC bit in CONCLR register.

AA is the Assert Acknowledge Flag. When set to 1, an acknowledge (low level to SDA) will be returned during the acknowledge clock pulse on the SCL line on the following situations:

1. The address in the Slave Address Register has been received.
2. The General Call address has been received while the General Call bit (GC) in ADR is set.
3. A data byte has been received while the I²C is in the master receiver mode.
4. A data byte has been received while the I²C is in the addressed slave receiver mode

The AA bit can be cleared by writing 1 to the AAC bit in the CONCLR register. When AA is 0, a not acknowledge (HIGH level to SDA) will be returned during the acknowledge clock pulse on the SCL line on the following situations:

1. A data byte has been received while the I²C is in the master receiver mode.
2. A data byte has been received while the I²C is in the addressed slave receiver mode.

42.7.2 I²C Status register

Each I²C Status register reflects the condition of the corresponding I²C interface. The I²C Status register is Read-Only.

Table 947. I²C Status register (STAT - address 0x400A 1004 (I2C0) and 0x400E 0004 (I2C1)) bit description

Bit	Symbol	Description	Reset value
2:0	-	These bits are unused and are always 0.	0
7:3	Status	These bits give the actual status information about the I ² C interface.	0x1F
31:8	-	Reserved. The value read from a reserved bit is not defined.	-

The three least significant bits are always 0. Taken as a byte, the status register contents represent a status code. There are 26 possible status codes. When the status code is 0xF8, there is no relevant information available and the SI bit is not set. All other 25 status codes correspond to defined I²C states. When any of these states entered, the SI bit will be set. For a complete list of status codes, refer to tables from [Table 962](#) to [Table 967](#).

42.7.3 I²C Data register

This register contains the data to be transmitted or the data just received. The CPU can read and write to this register only while it is not in the process of shifting a byte, when the SI bit is set. Data in DAT remains stable as long as the SI bit is set. Data in DAT is always shifted from right to left: the first bit to be transmitted is the MSB (bit 7), and after a byte has been received, the first bit of received data is located at the MSB of DAT.

Table 948. I²C Data register (DAT - 0x400A 1008 (I2C0) and 0x400E 0008 (I2C1)) bit description

Bit	Symbol	Description	Reset value
7:0	Data	This register holds data values that have been received or are to be transmitted.	0
31:8	-	Reserved. The value read from a reserved bit is not defined.	-

42.7.4 I²C Slave Address register 0

This register is readable and writable and are only used when an I²C interface is set to slave mode. In master mode, this register has no effect. The LSB of ADR is the General Call bit. When this bit is set, the General Call address (0x00) is recognized.

If this register contains 0x00, the I²C will not acknowledge any address on the bus. This register will be cleared to this disabled state on reset. Three additional slave address registers corresponding to addresses 1 to 3 are described [Table 955](#).

Table 949. I²C Slave Address register 0 (ADR0 - address 0x400A 100C (I2C0) and 0x400E 000C (I2C1)) bit description

Bit	Symbol	Description	Reset value
0	GC	General Call enable bit.	0
7:1	Address	The I ² C device address for slave mode.	0x00
31:8	-	Reserved. The value read from a reserved bit is not defined.	-

42.7.5 I²C SCL HIGH and LOW duty cycle registers

Table 950. I²C SCL HIGH Duty Cycle register (SCLH - address 0x400A 1010 (I2C0) and 0x400E 0010 (I2C1)) bit description

Bit	Symbol	Description	Reset value
15:0	SCLH	Count for SCL HIGH time period selection.	0x0004
31:16	-	Reserved. The value read from a reserved bit is not defined.	-

Table 951. I²C SCL Low duty cycle register (SCLL - address 0x400A 1014 (I2C0) and 0x400E 0014 (I2C1)) bit description

Bit	Symbol	Description	Reset value
15:0	SCLL	Count for SCL low time period selection.	0x0004
31:16	-	Reserved. The value read from a reserved bit is not defined.	-

42.7.5.1 Selecting the appropriate I²C data rate and duty cycle

Software must set values for the registers SCLH and SCLL to select the appropriate data rate and duty cycle. SCLH defines the number of C_PCLK cycles for the SCL HIGH time, SCLL defines the number of I2C_PCLK cycles for the SCL low time. The frequency is determined by the following formula (I2C_PCLK is the frequency of the peripheral I2C clock):

(11)

$$I^2C_{bitfrequency} = \frac{I2CPCLK}{I2CSCLH + I2CSCLL}$$

The values for SCLL and SCLH must ensure that the data rate is in the appropriate I²C data rate range. Each register value must be greater than or equal to 4. [Table 952](#) gives some examples of I²C-bus rates based on I2C_PCLK frequency and SCLL and SCLH values.

Table 952. SCLL + SCLH values for selected I²C clock values

I ² C mode	I ² C bit frequency	I2C_PCLK (MHz)								
		6	8	10	12	16	20	30	40	50
		SCLH + SCLL								
Standard mode	100 kHz	60	80	100	120	160	200	300	400	500
Fast-mode	400 kHz	15	20	25	30	40	50	75	100	125
Fast-mode Plus	1 MHz	-	8	10	12	16	20	30	40	50

SCLL and SCLH values should not necessarily be the same. Software can set different duty cycles on SCL by setting these two registers. For example, the I²C-bus specification defines the SCL low time and high time at different values for a Fast-mode and Fast-mode Plus I²C.

42.7.6 I²C Control Clear register

The CONCLR registers control clearing of bits in the CON register that controls operation of the I²C interface. Writing a one to a bit of this register causes the corresponding bit in the I²C control register to be cleared. Writing a zero has no effect.

Table 953. I²C Control Clear register (CONCLR - address 0x400A 1018 (I2C0) and 0x400E 0018 (I2C1)) bit description

Bit	Symbol	Description	Reset value
1:0	-	Reserved. User software should not write ones to reserved bits. The value read from a reserved bit is not defined.	-
2	AAC	Assert acknowledge Clear bit.	
3	SIC	I ² C interrupt Clear bit.	0
4	-	Reserved. User software should not write ones to reserved bits. The value read from a reserved bit is not defined.	-
5	STAC	START flag Clear bit.	0
6	I2ENC	I ² C interface Disable bit.	0
7	-	Reserved. User software should not write ones to reserved bits. The value read from a reserved bit is not defined.	-
31:8	-	Reserved. The value read from a reserved bit is not defined.	-

AAC is the Assert Acknowledge Clear bit. Writing a 1 to this bit clears the AA bit in the CONSET register. Writing 0 has no effect.

SIC is the I²C Interrupt Clear bit. Writing a 1 to this bit clears the SI bit in the CONSET register. Writing 0 has no effect.

STAC is the START flag Clear bit. Writing a 1 to this bit clears the STA bit in the CONSET register. Writing 0 has no effect.

I2ENC is the I²C Interface Disable bit. Writing a 1 to this bit clears the I2EN bit in the CONSET register. Writing 0 has no effect.

42.7.7 I²C Monitor mode control register

This register controls the Monitor mode which allows the I²C module to monitor traffic on the I²C bus without actually participating in traffic or interfering with the I²C bus.

Table 954. I²C Monitor mode control register (MMCTRL - address 0x400A 101C (I2C0) and 0x400E 001C (I2C1)) bit description

Bit	Symbol	Value	Description	Reset value
0	MM_ENA		Monitor mode enable.	0
		0	Monitor mode disabled.	
		1	The I ² C module will enter monitor mode. In this mode the SDA output will be forced high. This will prevent the I ² C module from outputting data of any kind (including ACK) onto the I ² C data bus. Depending on the state of the ENA_SCL bit, the output may be also forced high, preventing the module from having control over the I ² C clock line.	
1	ENA_SCL		SCL output enable.	0
		0	When this bit is cleared to '0', the SCL output will be forced high when the module is in monitor mode. As described above, this will prevent the module from having any control over the I ² C clock line.	
		1	When this bit is set, the I ² C module may exercise the same control over the clock line that it would in normal operation. This means that, acting as a slave peripheral, the I ² C module can "stretch" the clock line (hold it low) until it has had time to respond to an I ² C interrupt. [1]	
2	MATCH_ALL		Select interrupt register match.	0
		0	When this bit is cleared, an interrupt will only be generated when a match occurs to one of the (up-to) four address registers described above. That is, the module will respond as a normal slave as far as address-recognition is concerned.	
		1	When this bit is set to '1' and the I2C is in monitor mode, an interrupt will be generated on ANY address received. This will enable the part to monitor all traffic on the bus.	
31:3	-	-	Reserved. The value read from reserved bits is not defined.	-

[1] When the ENA_SCL bit is cleared and the I²C no longer has the ability to stall the bus, interrupt response time becomes important. To give the part more time to respond to an I²C interrupt under these conditions, a DATA_BUFFER register is used ([Section 42.7.9](#)) to hold received data for a full 9-bit word transmission time.

Remark: The ENA_SCL and MATCH_ALL bits have no effect if the MM_ENA is '0' (i.e. if the module is NOT in monitor mode).

42.7.7.1 Interrupt in Monitor mode

All interrupts will occur as normal when the module is in monitor mode. This means that the first interrupt will occur when an address-match is detected (any address received if the MATCH_ALL bit is set, otherwise an address matching one of the four address registers).

Subsequent to an address-match detection, interrupts will be generated after each data byte is received for a slave-write transfer, or after each byte that the module “thinks” it has transmitted for a slave-read transfer. In this second case, the data register will actually contain data transmitted by some other slave on the bus which was actually addressed by the master.

Following all of these interrupts, the processor may read the data register to see what was actually transmitted on the bus.

42.7.7.2 Loss of arbitration in Monitor mode

In monitor mode, the I²C module will not be able to respond to a request for information by the bus master or issue an ACK). Some other slave on the bus will respond instead. This will most probably result in a lost-arbitration state as far as our module is concerned.

Software should be aware of the fact that the module is in monitor mode and should not respond to any loss of arbitration state that is detected.

42.7.8 I²C Slave Address registers 1 to 3

These registers are readable and writable and are only used when an I²C interface is set to slave mode. In master mode, this register has no effect. The LSB of ADR is the General Call bit. When this bit is set, the General Call address (0x00) is recognized.

All four registers (including ADR0, see [Table 949](#)) will be cleared to this disabled state on reset.

You should program the Address field of all four registers to a non-zero value if you support slave operating mode. Otherwise a zero in any of the four registers will make the I2C module respond to the General Call address (0x00) unconditionally, i.e. irrespective of the state of the GC bit. In that case the I2C module state machine would enter state 0x60 (“own SLA+W received”), not state 0x70 (“General Call address received”) as expected for a General Call.

Only with all four Address fields set to non-zero values, the GC bit takes effect, and (if set) the state machine enters state 0x70 when receiving a General Call. Responding to a General Call is enabled if the GC bit is set in at least one of the four registers.

All four slave address comparators are always active. In case you want to be addressed by a single address only, program this address into ADR0, and duplicate the address into the three remaining registers. Set the corresponding MASKn register of these duplicates to 0x00.

For the description of ADR0, see [Section 42.7.4](#). The functionality of all ADRn registers is identical.

Table 955. I²C Slave Address registers (ADR - address 0x400A 1020 (ADR1) to 0x400A 1028 (ADR3) (I2C0) and 0x400E 0020 (ADR1) to 0x400E 0028 (ADR3) (I2C1)) bit description

Bit	Symbol	Description	Reset value
0	GC	General Call enable bit.	0
7:1	Address	The I ² C device address for slave mode.	0x00
31:8	-	Reserved. The value read from a reserved bit is not defined.	-

42.7.9 I²C Data buffer register

In monitor mode, the I²C module may lose the ability to stretch the clock (stall the bus) if the ENA_SCL bit is not set. This means that the processor will have a limited amount of time to read the contents of the data received on the bus. If the processor reads the DAT shift register, as it ordinarily would, it could have only one bit-time to respond to the interrupt before the received data is overwritten by new data.

To give the processor more time to respond, a new 8-bit, read-only DATA_BUFFER register will be added. The contents of the 8 MSBs of the DAT shift register will be transferred to the DATA_BUFFER automatically after every nine bits (8 bits of data plus ACK or NACK) has been received on the bus. This means that the processor will have nine bit transmission times to respond to the interrupt and read the data before it is overwritten.

The processor will still have the ability to read DAT directly, as usual, and the behavior of DAT will not be altered in any way.

Although the DATA_BUFFER register is primarily intended for use in monitor mode with the ENA_SCL bit = '0', it will be available for reading at any time under any mode of operation.

Table 956. I²C Data buffer register (DATA_BUFFER - address 0x400A 102C (I2C0) and 0x400E 002C (I2C1)) bit description

Bit	Symbol	Description	Reset value
7:0	Data	This register holds contents of the 8 MSBs of the DAT shift register.	0
31:8	-	Reserved. The value read from a reserved bit is not defined.	-

42.7.10 I²C Mask registers

The four mask registers each contain seven active bits (7:1). Any bit in these registers which is set to 1 will cause an automatic match on the corresponding bit of the received address when it is compared to the ADR_n register associated with that mask register. In other words, bits in an ADR_n register which are masked (set to 1) are not taken into account in determining an address match.

On reset, all mask register bits are cleared to 0.

The mask register has no effect on the comparison to the General Call address (0000000).

Bits(31:8) and bit(0) of the mask registers are unused and should not be written to. These bits will always read back as zeros.

When an address-match interrupt occurs, the processor will have to read the data register (DAT) to determine what the received address was that actually caused the match.

Table 957. I²C Mask registers (MASK - address 0x400A 1030 (MASK0) to 0x400A 103C (MASK3) (I2C0) and 0x400E 0030 (MASK0) to 0x400E 003C (MASK3) (I2C1)) bit description

Bit	Symbol	Description	Reset value
0	-	Reserved. User software should not write ones to reserved bits. This bit reads always back as 0.	0
7:1	MASK	Mask bits.	0x00
31:8	-	Reserved. The value read from a reserved bit is not defined.	-

42.8 I²C operating modes

In a given application, the I²C block may operate as a master, a slave, or both. In the slave mode, the I²C hardware looks for any one of its four slave addresses and the General Call address. If one of these addresses is detected, an interrupt is requested. If the processor wishes to become the bus master, the hardware waits until the bus is free before the master mode is entered so that a possible slave operation is not interrupted. If bus arbitration is lost in the master mode, the I²C block switches to the slave mode immediately and can detect its own slave address in the same serial transfer.

42.8.1 Master Transmitter mode

In this mode data is transmitted from master to slave. Before the master transmitter mode can be entered, the CONSET register must be initialized as shown in [Table 958](#). I2EN must be set to 1 to enable the I²C function. If the AA bit is 0, the I²C interface will not acknowledge any address when another device is master of the bus, so it can not enter slave mode. The STA, STO and SI bits must be 0. The SI Bit is cleared by writing 1 to the SIC bit in the CONCLR register. The STA bit should be cleared after writing the slave address.

Table 958. CONSET used to configure Master mode

Bit	7	6	5	4	3	2	1	0
Symbol	-	I2EN	STA	STO	SI	AA	-	-
Value	-	1	0	0	0	0	-	-

The first byte transmitted contains the slave address of the receiving device (7 bits) and the data direction bit. In this mode the data direction bit (R/W) should be 0 which means Write. The first byte transmitted contains the slave address and Write bit. Data is transmitted 8 bits at a time. After each byte is transmitted, an acknowledge bit is received. START and STOP conditions are output to indicate the beginning and the end of a serial transfer.

The I²C interface will enter master transmitter mode when software sets the STA bit. The I²C logic will send the START condition as soon as the bus is free. After the START condition is transmitted, the SI bit is set, and the status code in the STAT register is 0x08. This status code is used to vector to a state service routine which will load the slave address and Write bit to the DAT register, and then clear the SI bit. SI is cleared by writing a 1 to the SIC bit in the CONCLR register.

When the slave address and R/W bit have been transmitted and an acknowledgment bit has been received, the SI bit is set again, and the possible status codes now are 0x18, 0x20, or 0x38 for the master mode, or 0x68, 0x78, or 0xB0 if the slave mode was enabled

(by setting AA to 1). The appropriate actions to be taken for each of these status codes are shown in [Table 962](#) to [Table 967](#).

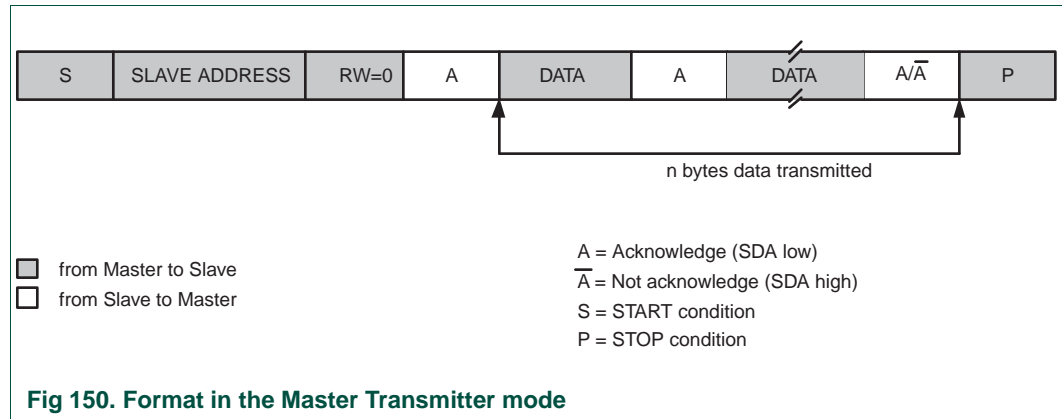

42.8.2 Master Receiver mode

In the master receiver mode, data is received from a slave transmitter. The transfer is initiated in the same way as in the master transmitter mode. When the START condition has been transmitted, the interrupt service routine must load the slave address and the data direction bit to the I²C Data register (DAT), and then clear the SI bit. In this case, the data direction bit (R/W) should be 1 to indicate a read.

When the slave address and data direction bit have been transmitted and an acknowledge bit has been received, the SI bit is set, and the Status Register will show the status code. For master mode, the possible status codes are 0x40, 0x48, or 0x38. For slave mode, the possible status codes are 0x68, 0x78, or 0xB0. For details, refer to [Table 963](#).

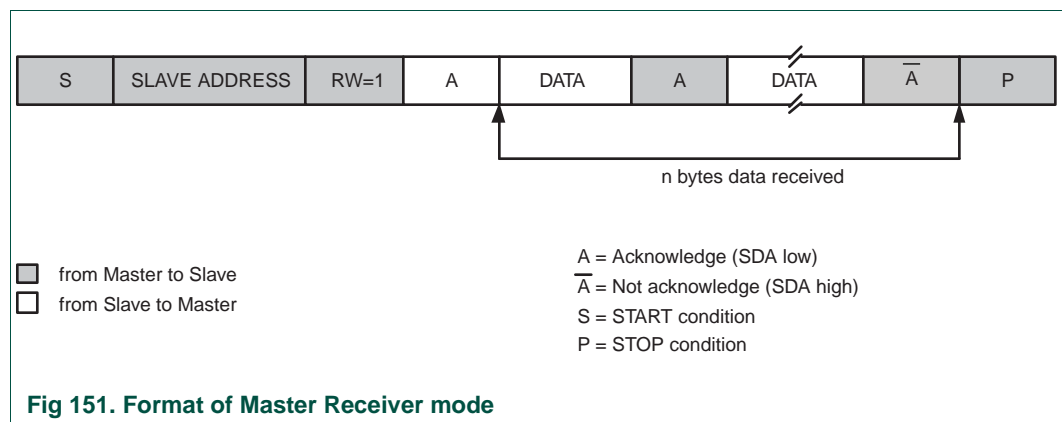

After a Repeated START condition, I²C may switch to the master transmitter mode.

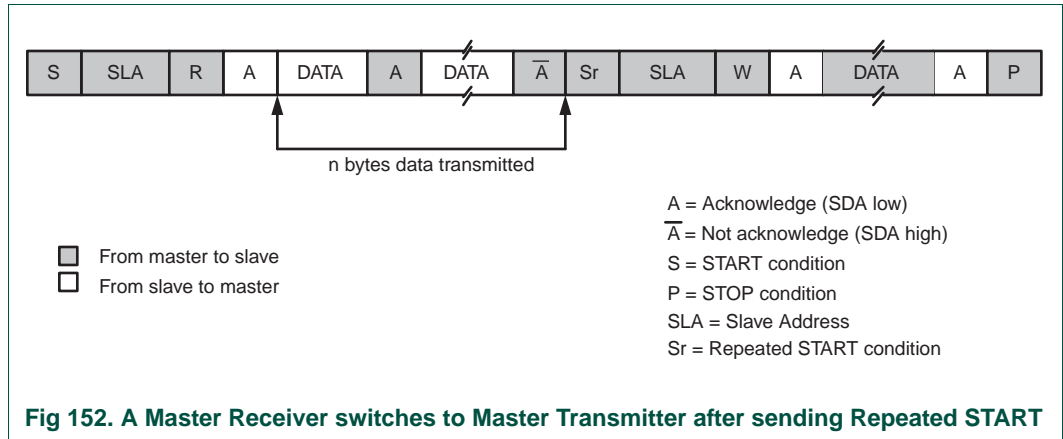

42.8.3 Slave Receiver mode

In the slave receiver mode, data bytes are received from a master transmitter. To initialize the slave receiver mode, write any of the Slave Address registers (ADR0-3) and write the I²C Control Set register (CONSET) as shown in [Table 959](#).

Table 959. CONSET used to configure Slave mode

Bit	7	6	5	4	3	2	1	0
Symbol	-	I2EN	STA	STO	SI	AA	-	-
Value	-	1	0	0	0	1	-	-

I2EN must be set to 1 to enable the I²C function. AA bit must be set to 1 to acknowledge its own slave address or the General Call address. The STA, STO and SI bits are set to 0.

After ADR and CONSET are initialized, the I²C interface waits until it is addressed by its own address or general address followed by the data direction bit. If the direction bit is 0 (W), it enters slave receiver mode. If the direction bit is 1 (R), it enters slave transmitter mode. After the address and direction bit have been received, the SI bit is set and a valid status code can be read from the Status register (STAT). Refer to [Table 966](#) for the status codes and actions.

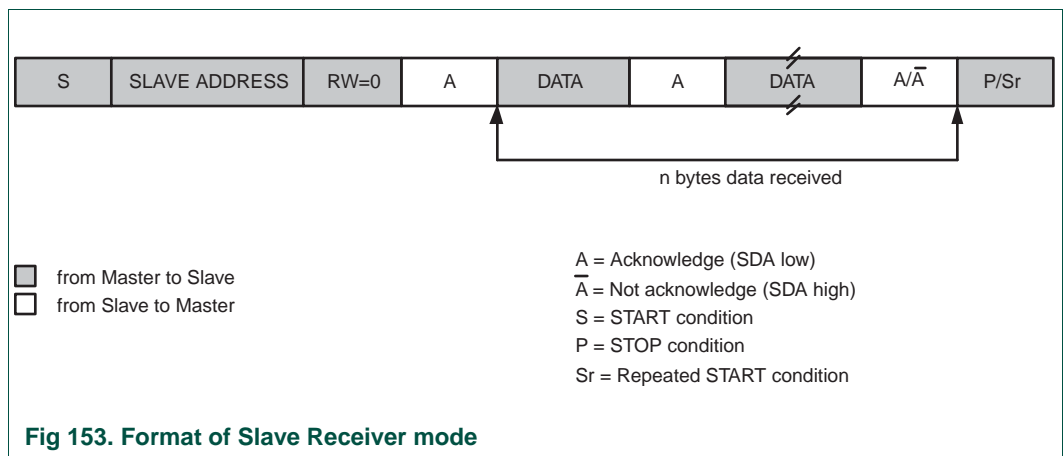

42.8.4 Slave Transmitter mode

The first byte is received and handled as in the slave receiver mode. However, in this mode, the direction bit will be 1, indicating a read operation. Serial data is transmitted via SDA while the serial clock is input through SCL. START and STOP conditions are recognized as the beginning and end of a serial transfer. In a given application, I²C may operate as a master and as a slave. In the slave mode, the I²C hardware looks for its own slave address and the General Call address. If one of these addresses is detected, an interrupt is requested. When the microcontroller wishes to become the bus master, the hardware waits until the bus is free before the master mode is entered so that a possible slave action is not interrupted. If bus arbitration is lost in the master mode, the I²C interface switches to the slave mode immediately and can detect its own slave address in the same serial transfer.

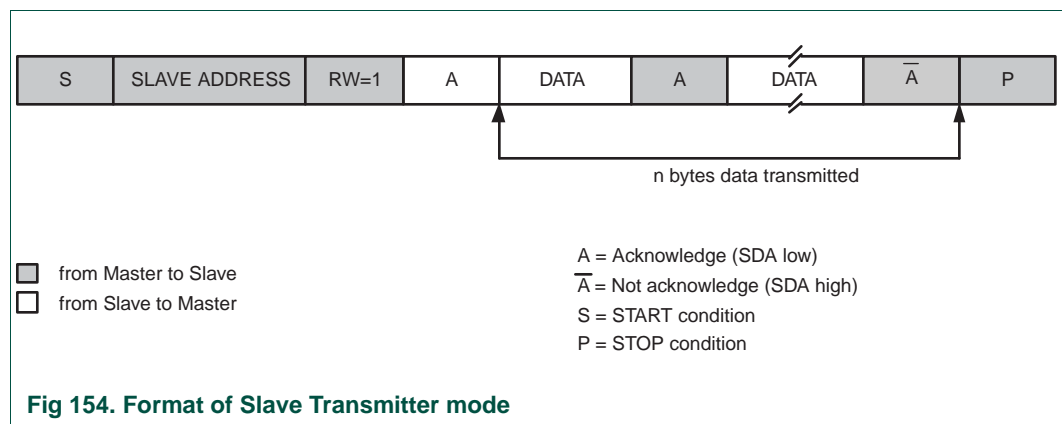

Fig 154. Format of Slave Transmitter mode

42.9 I²C implementation and operation

[Figure 155](#) shows how the on-chip I²C-bus interface is implemented, and the following text describes the individual blocks.

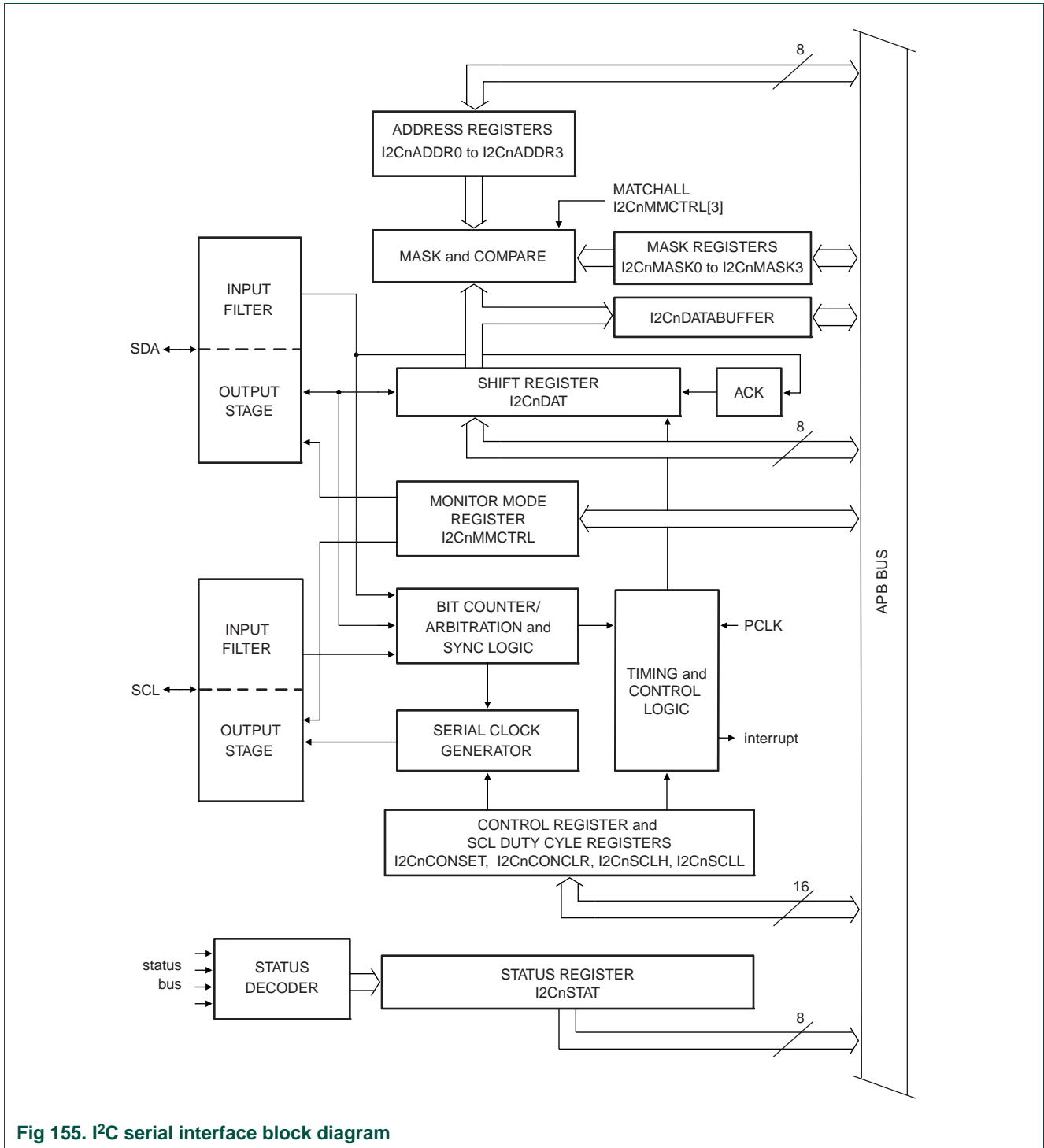

Fig 155. I²C serial interface block diagram

42.9.1 Input filters and output stages

Input signals are synchronized with the internal clock, and spikes shorter than three clocks are filtered out.

The output for I²C is a special pad designed to conform to the I²C specification.

42.9.2 Address Registers, ADR0 to ADR3

These registers may be loaded with the 7-bit slave address (7 most significant bits) to which the I²C block will respond when programmed as a slave transmitter or receiver. The LSB (GC) is used to enable General Call address (0x00) recognition. When multiple slave addresses are enabled, the actual address received may be read from the DAT register at the state where the own slave address has been received.

42.9.3 Address mask registers, MASK0 to MASK3

The four mask registers each contain seven active bits (7:1). Any bit in these registers which is set to 1 will cause an automatic match on the corresponding bit of the received address when it is compared to the ADR_n register associated with that mask register. In other words, bits in an ADR_n register which are masked (set to 1) are not taken into account in determining an address match.

When an address-match interrupt occurs, the processor will have to read the data register (DAT) to determine which received address actually caused the match.

42.9.4 Comparator

The comparator compares the received 7-bit slave address with its own slave address (7 most significant bits in ADR). It also compares the first received 8-bit byte with the General Call address (0x00). If an equality is found, the appropriate status bits are set and an interrupt is requested.

42.9.5 Shift register, DAT

This 8-bit register contains a byte of serial data to be transmitted or a byte which has just been received. Data in DAT is always shifted from right to left; the first bit to be transmitted is the MSB (bit 7) and, after a byte has been received, the first bit of received data is located at the MSB of DAT. While data is being shifted out, data on the bus is simultaneously being shifted in; DAT always contains the last byte present on the bus. Thus, in the event of lost arbitration, the transition from master transmitter to slave receiver is made with the correct data in DAT.

42.9.6 Arbitration and synchronization logic

In the master transmitter mode, the arbitration logic checks that every transmitted logic 1 actually appears as a logic 1 on the I²C-bus. If another device on the bus overrules a logic 1 and pulls the SDA line low, arbitration is lost, and the I²C block immediately changes from master transmitter to slave receiver. The I²C block will continue to output clock pulses (on SCL) until transmission of the current serial byte is complete.

Arbitration may also be lost in the master receiver mode. Loss of arbitration in this mode can only occur while the I²C block is returning a “not acknowledge”: (logic 1) to the bus. Arbitration is lost when another device on the bus pulls this signal low. Since this can occur only at the end of a serial byte, the I²C block generates no further clock pulses. [Figure 156](#) shows the arbitration procedure.

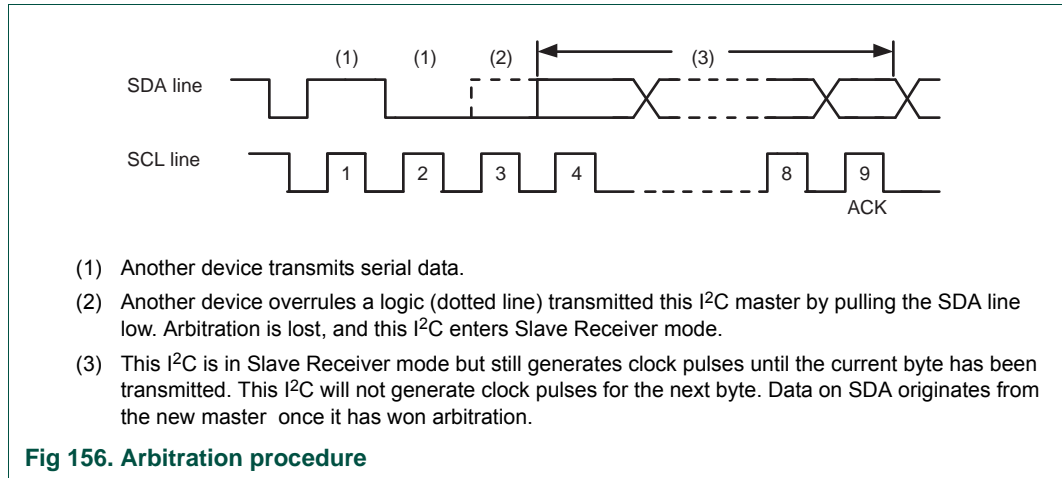

The synchronization logic will synchronize the serial clock generator with the clock pulses on the SCL line from another device. If two or more master devices generate clock pulses, the “mark” duration is determined by the device that generates the shortest “marks”, and the “space” duration is determined by the device that generates the longest “spaces”. [Figure 157](#) shows the synchronization procedure.

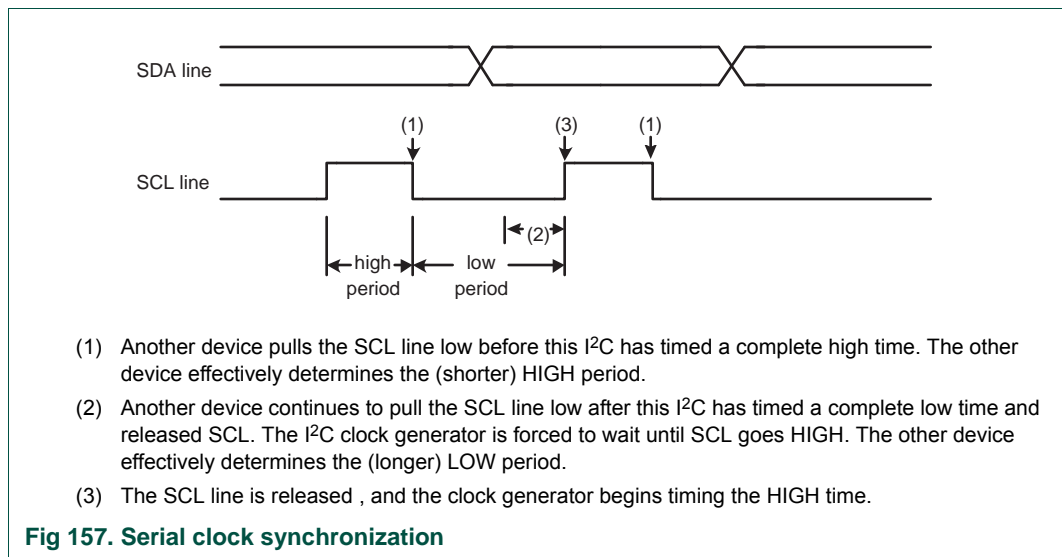

A slave may stretch the space duration to slow down the bus master. The space duration may also be stretched for handshaking purposes. This can be done after each bit or after a complete byte transfer. the I²C block will stretch the SCL space duration after a byte has been transmitted or received and the acknowledge bit has been transferred. The serial interrupt flag (SI) is set, and the stretching continues until the serial interrupt flag is cleared.

42.9.7 Serial clock generator

This programmable clock pulse generator provides the SCL clock pulses when the I²C block is in the master transmitter or master receiver mode. It is switched off when the I²C block is in slave mode. The I²C output clock frequency and duty cycle is programmable

via the I²C Clock Control Registers. See the description of the SCLL and SCLH registers for details. The output clock pulses have a duty cycle as programmed unless the bus is synchronizing with other SCL clock sources as described above.

42.9.8 Timing and control

The timing and control logic generates the timing and control signals for serial byte handling. This logic block provides the shift pulses for DAT, enables the comparator, generates and detects START and STOP conditions, receives and transmits acknowledge bits, controls the master and slave modes, contains interrupt request logic, and monitors the I²C-bus status.

42.9.9 Control register, CONSET and CONCLR

The I²C control register contains bits used to control the following I²C block functions: start and restart of a serial transfer, termination of a serial transfer, bit rate, address recognition, and acknowledgment.

The contents of the I²C control register may be read as CONSET. Writing to CONSET will set bits in the I²C control register that correspond to ones in the value written. Conversely, writing to CONCLR will clear bits in the I²C control register that correspond to ones in the value written.

42.9.10 Status decoder and status register

The status decoder takes all of the internal status bits and compresses them into a 5-bit code. This code is unique for each I²C-bus status. The 5-bit code may be used to generate vector addresses for fast processing of the various service routines. Each service routine processes a particular bus status. There are 26 possible bus states if all four modes of the I²C block are used. The 5-bit status code is latched into the five most significant bits of the status register when the serial interrupt flag is set (by hardware) and remains stable until the interrupt flag is cleared by software. The three least significant bits of the status register are always zero. If the status code is used as a vector to service routines, then the routines are displaced by eight address locations. Eight bytes of code is sufficient for most of the service routines (see the software example in this section).

42.10 Details of I²C operating modes

The four operating modes are:

- Master Transmitter
- Master Receiver
- Slave Receiver
- Slave Transmitter

Data transfers in each mode of operation are shown in [Figure 158](#), [Figure 159](#), [Figure 160](#), [Figure 161](#), and [Figure 162](#). [Table 960](#) lists abbreviations used in these figures when describing the I²C operating modes.

Table 960. Abbreviations used to describe an I²C operation

Abbreviation	Explanation
S	START Condition
SLA	7-bit slave address
R	Read bit (HIGH level at SDA)
W	Write bit (LOW level at SDA)
A	Acknowledge bit (LOW level at SDA)
\bar{A}	Not acknowledge bit (HIGH level at SDA)
Data	8-bit data byte
P	STOP condition

In [Figure 158](#) to [Figure 162](#), circles are used to indicate when the serial interrupt flag is set. The numbers in the circles show the status code held in the STAT register. At these points, a service routine must be executed to continue or complete the serial transfer. These service routines are not critical since the serial transfer is suspended until the serial interrupt flag is cleared by software.

When a serial interrupt routine is entered, the status code in STAT is used to branch to the appropriate service routine. For each status code, the required software action and details of the following serial transfer are given in tables from [Table 962](#) to [Table 968](#).

42.10.1 Master Transmitter mode

In the master transmitter mode, a number of data bytes are transmitted to a slave receiver (see [Figure 158](#)). Before the master transmitter mode can be entered, CON must be initialized as follows:

Table 961. CONSET used to initialize Master Transmitter mode

Bit	7	6	5	4	3	2	1	0
Symbol	-	I2EN	STA	STO	SI	AA	-	-
Value	-	1	0	0	0	x	-	-

The I²C rate must also be configured in the SCLL and SCLH registers. I2EN must be set to logic 1 to enable the I²C block. If the AA bit is reset, the I²C block will not acknowledge its own slave address or the General Call address in the event of another device becoming master of the bus. In other words, if AA is reset, the I²C interface cannot enter slave mode. STA, STO, and SI must be reset.

The master transmitter mode may now be entered by setting the STA bit. The I²C logic will now test the I²C-bus and generate a START condition as soon as the bus becomes free. When a START condition is transmitted, the serial interrupt flag (SI) is set, and the status code in the status register (STAT) will be 0x08. This status code is used by the interrupt service routine to enter the appropriate state service routine that loads DAT with the slave address and the data direction bit (SLA+W). The SI bit in CON must then be reset before the serial transfer can continue.

When the slave address and the direction bit have been transmitted and an acknowledgment bit has been received, the serial interrupt flag (SI) is set again, and a number of status codes in STAT are possible. There are 0x18, 0x20, or 0x38 for the master mode and also 0x68, 0x78, or 0xB0 if the slave mode was enabled (AA = logic 1). The appropriate action to be taken for each of these status codes is detailed in [Table 962](#). After a Repeated START condition (state 0x10). The I²C block may switch to the master receiver mode by loading DAT with SLA+R).

Table 962. Master Transmitter mode

Status Code (STAT)	Status of the I ² C-bus and hardware	Application software response					Next action taken by I ² C hardware
		To/From DAT	To CON				
			STA	STO	SI	AA	
0x08	A START condition has been transmitted.	Load SLA+W; clear STA	X	0	0	X	SLA+W will be transmitted; ACK bit will be received.
0x10	A Repeated START condition has been transmitted.	Load SLA+W or	X	0	0	X	As above.
		Load SLA+R; Clear STA	X	0	0	X	SLA+R will be transmitted; the I ² C block will be switched to MST/REC mode.
0x18	SLA+W has been transmitted; ACK has been received.	Load data byte or	0	0	0	X	Data byte will be transmitted; ACK bit will be received.
		No DAT action or	1	0	0	X	Repeated START will be transmitted.
		No DAT action or	0	1	0	X	STOP condition will be transmitted; STO flag will be reset.
		No DAT action	1	1	0	X	STOP condition followed by a START condition will be transmitted; STO flag will be reset.
0x20	SLA+W has been transmitted; NOT ACK has been received.	Load data byte or	0	0	0	X	Data byte will be transmitted; ACK bit will be received.
		No DAT action or	1	0	0	X	Repeated START will be transmitted.
		No DAT action or	0	1	0	X	STOP condition will be transmitted; STO flag will be reset.
		No DAT action	1	1	0	X	STOP condition followed by a START condition will be transmitted; STO flag will be reset.
0x28	Data byte in DAT has been transmitted; ACK has been received.	Load data byte or	0	0	0	X	Data byte will be transmitted; ACK bit will be received.
		No DAT action or	1	0	0	X	Repeated START will be transmitted.
		No DAT action or	0	1	0	X	STOP condition will be transmitted; STO flag will be reset.
		No DAT action	1	1	0	X	STOP condition followed by a START condition will be transmitted; STO flag will be reset.
0x30	Data byte in DAT has been transmitted; NOT ACK has been received.	Load data byte or	0	0	0	X	Data byte will be transmitted; ACK bit will be received.
		No DAT action or	1	0	0	X	Repeated START will be transmitted.
		No DAT action or	0	1	0	X	STOP condition will be transmitted; STO flag will be reset.
		No DAT action	1	1	0	X	STOP condition followed by a START condition will be transmitted; STO flag will be reset.
0x38	Arbitration lost in SLA+R/W or Data bytes.	No DAT action or	0	0	0	X	I ² C-bus will be released; not addressed slave will be entered.
		No DAT action	1	0	0	X	A START condition will be transmitted when the bus becomes free.

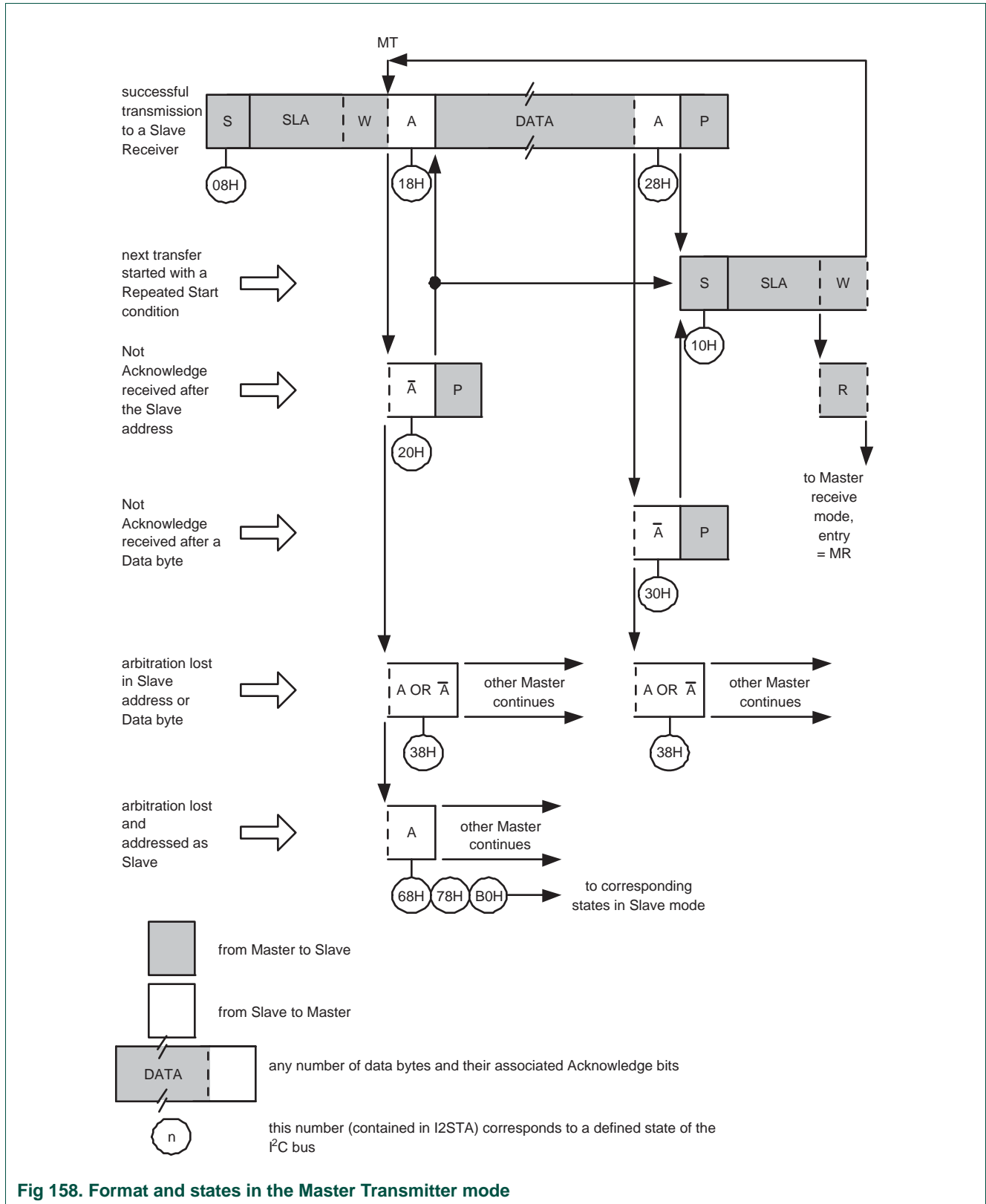

Fig 158. Format and states in the Master Transmitter mode

42.10.2 Master Receiver mode

In the master receiver mode, a number of data bytes are received from a slave transmitter (see [Figure 159](#)). The transfer is initialized as in the master transmitter mode. When the START condition has been transmitted, the interrupt service routine must load DAT with the 7-bit slave address and the data direction bit (SLA+R). The SI bit in CON must then be cleared before the serial transfer can continue.

When the slave address and the data direction bit have been transmitted and an acknowledgment bit has been received, the serial interrupt flag (SI) is set again, and a number of status codes in STAT are possible. These are 0x40, 0x48, or 0x38 for the master mode and also 0x68, 0x78, or 0xB0 if the slave mode was enabled (AA = 1). The appropriate action to be taken for each of these status codes is detailed in [Table 963](#). After a Repeated START condition (state 0x10), the I²C block may switch to the master transmitter mode by loading DAT with SLA+W.

Table 963. Master Receiver mode

Status Code (STAT)	Status of the I ² C-bus and hardware	Application software response					Next action taken by I ² C hardware
		To/From DAT	To CON				
			STA	STO	SI	AA	
0x08	A START condition has been transmitted.	Load SLA+R	X	0	0	X	SLA+R will be transmitted; ACK bit will be received.
0x10	A Repeated START condition has been transmitted.	Load SLA+R or	X	0	0	X	As above.
		Load SLA+W	X	0	0	X	SLA+W will be transmitted; the I ² C block will be switched to MST/TRX mode.
0x38	Arbitration lost in NOT ACK bit.	No DAT action or	0	0	0	X	I ² C-bus will be released; the I ² C block will enter slave mode.
		No DAT action	1	0	0	X	A START condition will be transmitted when the bus becomes free.
0x40	SLA+R has been transmitted; ACK has been received.	No DAT action or	0	0	0	0	Data byte will be received; NOT ACK bit will be returned.
		No DAT action	0	0	0	1	Data byte will be received; ACK bit will be returned.
0x48	SLA+R has been transmitted; NOT ACK has been received.	No DAT action or	1	0	0	X	Repeated START condition will be transmitted.
		No DAT action or	0	1	0	X	STOP condition will be transmitted; STO flag will be reset.
		No DAT action	1	1	0	X	STOP condition followed by a START condition will be transmitted; STO flag will be reset.
0x50	Data byte has been received; ACK has been returned.	Read data byte or	0	0	0	0	Data byte will be received; NOT ACK bit will be returned.
		Read data byte	0	0	0	1	Data byte will be received; ACK bit will be returned.
0x58	Data byte has been received; NOT ACK has been returned.	Read data byte or	1	0	0	X	Repeated START condition will be transmitted.
		Read data byte or	0	1	0	X	STOP condition will be transmitted; STO flag will be reset.
		Read data byte	1	1	0	X	STOP condition followed by a START condition will be transmitted; STO flag will be reset.

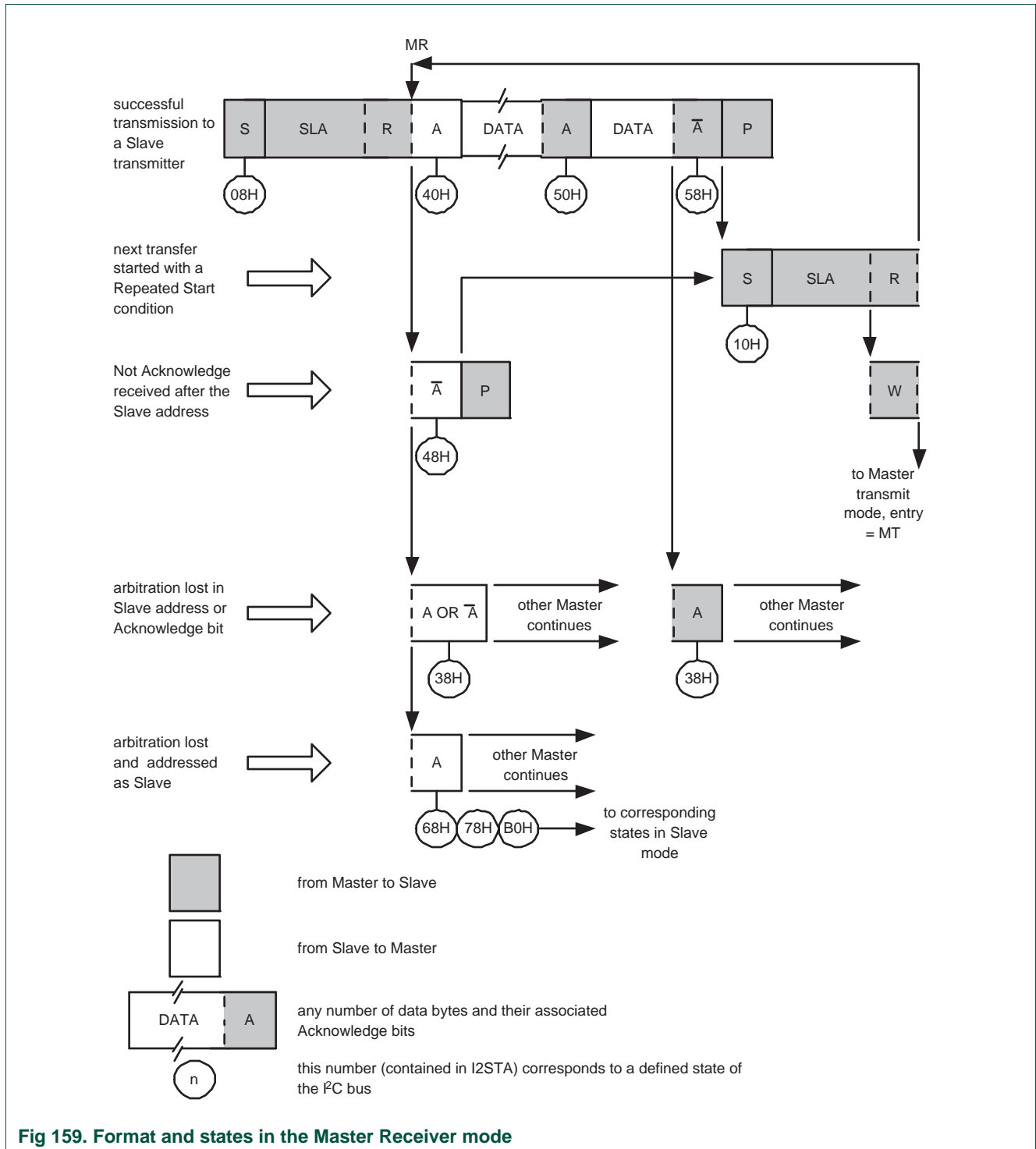

Fig 159. Format and states in the Master Receiver mode

42.10.3 Slave Receiver mode

In the slave receiver mode, a number of data bytes are received from a master transmitter (see [Figure 160](#)). To initiate the slave receiver mode, ADR and CON must be loaded as follows:

Table 964. ADR usage in Slave Receiver mode

Bit	7	6	5	4	3	2	1	0
Symbol	own slave 7-bit address							GC

The upper 7 bits are the address to which the I²C block will respond when addressed by a master. If the LSB (GC) is set, the I²C block will respond to the General Call address (0x00); otherwise it ignores the General Call address.

Table 965. CONSET used to initialize Slave Receiver mode

Bit	7	6	5	4	3	2	1	0
Symbol	-	I2EN	STA	STO	SI	AA	-	-
Value	-	1	0	0	0	1	-	-

The I²C-bus rate settings do not affect the I²C block in the slave mode. I2EN must be set to logic 1 to enable the I²C block. The AA bit must be set to enable the I²C block to acknowledge its own slave address or the General Call address. STA, STO, and SI must be reset.

When ADR and CON have been initialized, the I²C block waits until it is addressed by its own slave address followed by the data direction bit which must be “0” (W) for the I²C block to operate in the slave receiver mode. After its own slave address and the W bit have been received, the serial interrupt flag (SI) is set and a valid status code can be read from STAT. This status code is used to vector to a state service routine. The appropriate action to be taken for each of these status codes is detailed in [Table 966](#). The slave receiver mode may also be entered if arbitration is lost while the I²C block is in the master mode (see status 0x68 and 0x78).

If the AA bit is reset during a transfer, the I²C block will return a not acknowledge (logic 1) to SDA after the next received data byte. While AA is reset, the I²C block does not respond to its own slave address or a General Call address. However, the I²C-bus is still monitored and address recognition may be resumed at any time by setting AA. This means that the AA bit may be used to temporarily isolate the I²C block from the I²C-bus.

Table 966. Slave Receiver mode

Status Code (STAT)	Status of the I ² C-bus and hardware	Application software response					Next action taken by I ² C hardware
		To/From DAT	To CON				
			STA	STO	SI	AA	
0x60	Own SLA+W has been received; ACK has been returned.	No DAT action or	X	0	0	0	Data byte will be received and NOT ACK will be returned.
		No DAT action	X	0	0	1	Data byte will be received and ACK will be returned.
0x68	Arbitration lost in SLA+R/W as master; Own SLA+W has been received, ACK returned.	No DAT action or	X	0	0	0	Data byte will be received and NOT ACK will be returned.
		No DAT action	X	0	0	1	Data byte will be received and ACK will be returned.
0x70	General call address (0x00) has been received; ACK has been returned.	No DAT action or	X	0	0	0	Data byte will be received and NOT ACK will be returned.
		No DAT action	X	0	0	1	Data byte will be received and ACK will be returned.
0x78	Arbitration lost in SLA+R/W as master; General call address has been received, ACK has been returned.	No DAT action or	X	0	0	0	Data byte will be received and NOT ACK will be returned.
		No DAT action	X	0	0	1	Data byte will be received and ACK will be returned.
0x80	Previously addressed with own SLV address; DATA has been received; ACK has been returned.	Read data byte or	X	0	0	0	Data byte will be received and NOT ACK will be returned.
		Read data byte	X	0	0	1	Data byte will be received and ACK will be returned.
0x88	Previously addressed with own SLA; DATA byte has been received; NOT ACK has been returned.	Read data byte or	0	0	0	0	Switched to not addressed SLV mode; no recognition of own SLA or General call address.
		Read data byte or	0	0	0	1	Switched to not addressed SLV mode; Own SLA will be recognized; General call address will be recognized if ADR[0] = logic 1.
		Read data byte or	1	0	0	0	Switched to not addressed SLV mode; no recognition of own SLA or General call address. A START condition will be transmitted when the bus becomes free.
		Read data byte	1	0	0	1	Switched to not addressed SLV mode; Own SLA will be recognized; General call address will be recognized if ADR[0] = logic 1. A START condition will be transmitted when the bus becomes free.
0x90	Previously addressed with General Call; DATA byte has been received; ACK has been returned.	Read data byte or	X	0	0	0	Data byte will be received and NOT ACK will be returned.
		Read data byte	X	0	0	1	Data byte will be received and ACK will be returned.

Table 966. Slave Receiver mode ...continued

Status Code (STAT)	Status of the I ² C-bus and hardware	Application software response				Next action taken by I ² C hardware	
		To/From DAT	To CON				
			STA	STO	SI	AA	
0x98	Previously addressed with General Call; DATA byte has been received; NOT ACK has been returned.	Read data byte or	0	0	0	0	Switched to not addressed SLV mode; no recognition of own SLA or General call address.
		Read data byte or	0	0	0	1	Switched to not addressed SLV mode; Own SLA will be recognized; General call address will be recognized if ADR[0] = logic 1.
		Read data byte or	1	0	0	0	Switched to not addressed SLV mode; no recognition of own SLA or General call address. A START condition will be transmitted when the bus becomes free.
		Read data byte	1	0	0	1	Switched to not addressed SLV mode; Own SLA will be recognized; General call address will be recognized if ADR[0] = logic 1. A START condition will be transmitted when the bus becomes free.
0xA0	A STOP condition or Repeated START condition has been received while still addressed as SLV/REC or SLV/TRX.	No STDAT action or	0	0	0	0	Switched to not addressed SLV mode; no recognition of own SLA or General call address.
		No STDAT action or	0	0	0	1	Switched to not addressed SLV mode; Own SLA will be recognized; General call address will be recognized if ADR[0] = logic 1.
		No STDAT action or	1	0	0	0	Switched to not addressed SLV mode; no recognition of own SLA or General call address. A START condition will be transmitted when the bus becomes free.
		No STDAT action	1	0	0	1	Switched to not addressed SLV mode; Own SLA will be recognized; General call address will be recognized if ADR[0] = logic 1. A START condition will be transmitted when the bus becomes free.

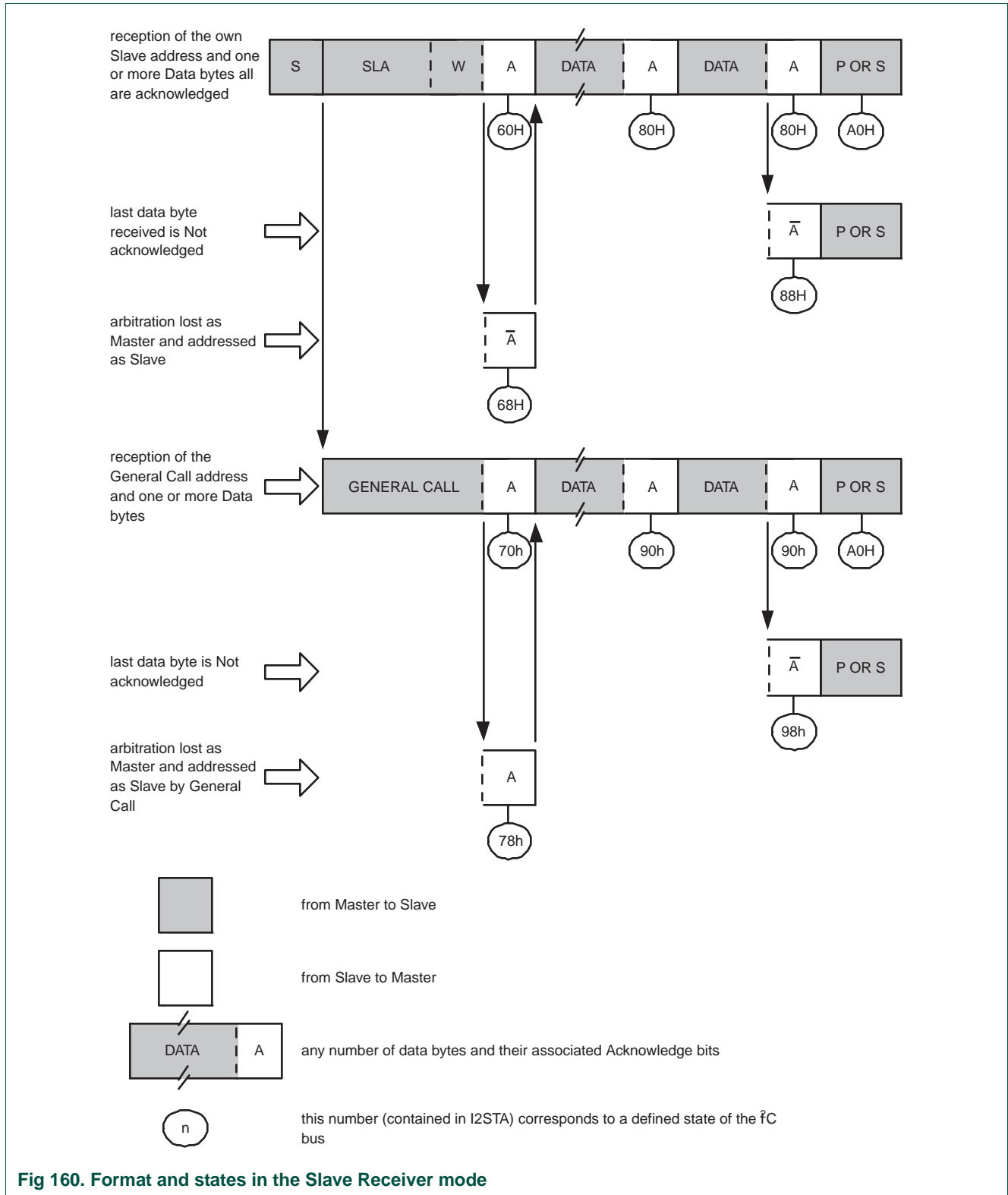

Fig 160. Format and states in the Slave Receiver mode

42.10.4 Slave Transmitter mode

In the slave transmitter mode, a number of data bytes are transmitted to a master receiver (see [Figure 161](#)). Data transfer is initialized as in the slave receiver mode. When ADR and CON have been initialized, the I²C block waits until it is addressed by its own slave address followed by the data direction bit which must be “1” (R) for the I²C block to operate in the slave transmitter mode. After its own slave address and the R bit have been received, the serial interrupt flag (SI) is set and a valid status code can be read from STAT. This status code is used to vector to a state service routine, and the appropriate action to be taken for each of these status codes is detailed in [Table 967](#). The slave transmitter mode may also be entered if arbitration is lost while the I²C block is in the master mode (see state 0xB0).

If the AA bit is reset during a transfer, the I²C block will transmit the last byte of the transfer and enter state 0xC0 or 0xC8. The I²C block is switched to the not addressed slave mode and will ignore the master receiver if it continues the transfer. Thus the master receiver receives all 1s as serial data. While AA is reset, the I²C block does not respond to its own slave address or a General Call address. However, the I²C-bus is still monitored, and address recognition may be resumed at any time by setting AA. This means that the AA bit may be used to temporarily isolate the I²C block from the I²C-bus.

Table 967. Slave Transmitter mode

Status Code (STAT)	Status of the I ² C-bus and hardware	Application software response					Next action taken by I ² C hardware
		To/From DAT	To CON				
			STA	STO	SI	AA	
0xA8	Own SLA+R has been received; ACK has been returned.	Load data byte or	X	0	0	0	Last data byte will be transmitted and ACK bit will be received.
		Load data byte	X	0	0	1	Data byte will be transmitted; ACK will be received.
0xB0	Arbitration lost in SLA+R/W as master; Own SLA+R has been received, ACK has been returned.	Load data byte or	X	0	0	0	Last data byte will be transmitted and ACK bit will be received.
		Load data byte	X	0	0	1	Data byte will be transmitted; ACK bit will be received.
0xB8	Data byte in DAT has been transmitted; ACK has been received.	Load data byte or	X	0	0	0	Last data byte will be transmitted and ACK bit will be received.
		Load data byte	X	0	0	1	Data byte will be transmitted; ACK bit will be received.
0xC0	Data byte in DAT has been transmitted; NOT ACK has been received.	No DAT action or	0	0	0	0	Switched to not addressed SLV mode; no recognition of own SLA or General call address.
		No DAT action or	0	0	0	1	Switched to not addressed SLV mode; Own SLA will be recognized; General call address will be recognized if ADR[0] = logic 1.
		No DAT action or	1	0	0	0	Switched to not addressed SLV mode; no recognition of own SLA or General call address. A START condition will be transmitted when the bus becomes free.
		No DAT action	1	0	0	1	Switched to not addressed SLV mode; Own SLA will be recognized; General call address will be recognized if ADR[0] = logic 1. A START condition will be transmitted when the bus becomes free.
0xC8	Last data byte in DAT has been transmitted (AA = 0); ACK has been received.	No DAT action or	0	0	0	0	Switched to not addressed SLV mode; no recognition of own SLA or General call address.
		No DAT action or	0	0	0	1	Switched to not addressed SLV mode; Own SLA will be recognized; General call address will be recognized if ADR[0] = logic 1.
		No DAT action or	1	0	0	0	Switched to not addressed SLV mode; no recognition of own SLA or General call address. A START condition will be transmitted when the bus becomes free.
		No DAT action	1	0	0	01	Switched to not addressed SLV mode; Own SLA will be recognized; General call address will be recognized if ADR.0 = logic 1. A START condition will be transmitted when the bus becomes free.

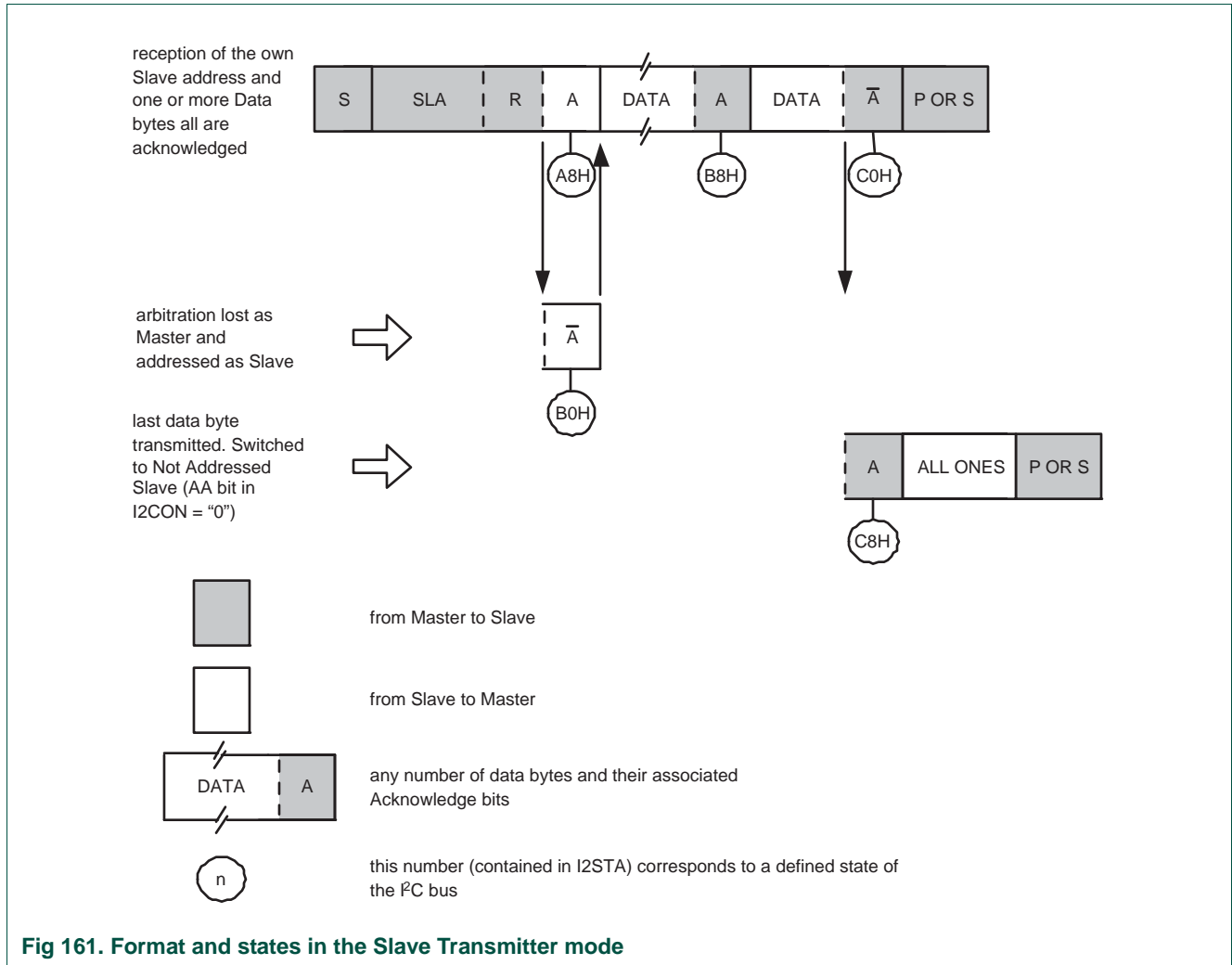

42.10.5 Miscellaneous states

There are two STAT codes that do not correspond to a defined I²C hardware state (see [Table 968](#)). These are discussed below.

42.10.5.1 STAT = 0xF8

This status code indicates that no relevant information is available because the serial interrupt flag, SI, is not yet set. This occurs between other states and when the I²C block is not involved in a serial transfer.

42.10.5.2 STAT = 0x00

This status code indicates that a bus error has occurred during an I²C serial transfer. A bus error is caused when a START or STOP condition occurs at an illegal position in the format frame. Examples of such illegal positions are during the serial transfer of an address byte, a data byte, or an acknowledge bit. A bus error may also be caused when external interference disturbs the internal I²C block signals. When a bus error occurs, SI is set. To recover from a bus error, the STO flag must be set and SI must be cleared. This

causes the I²C block to enter the “not addressed” slave mode (a defined state) and to clear the STO flag (no other bits in CON are affected). The SDA and SCL lines are released (a STOP condition is not transmitted).

Table 968. Miscellaneous States

Status Code (STAT)	Status of the I ² C-bus and hardware	Application software response				Next action taken by I ² C hardware	
		To/From DAT	To CON				
			STA	STO	SI		AA
0xF8	No relevant state information available; SI = 0.	No DAT action	No CON action			Wait or proceed current transfer.	
0x00	Bus error during MST or selected slave modes, due to an illegal START or STOP condition. State 0x00 can also occur when interference causes the I ² C block to enter an undefined state.	No DAT action	0	1	0	X	Only the internal hardware is affected in the MST or addressed SLV modes. In all cases, the bus is released and the I ² C block is switched to the not addressed SLV mode. STO is reset.

42.10.6 Some special cases

The I²C hardware has facilities to handle the following special cases that may occur during a serial transfer:

- Simultaneous Repeated START conditions from two masters
- Data transfer after loss of arbitration
- Forced access to the I²C-bus
- I²C-bus obstructed by a LOW level on SCL or SDA
- Bus error

42.10.6.1 Simultaneous Repeated START conditions from two masters

A Repeated START condition may be generated in the master transmitter or master receiver modes. A special case occurs if another master simultaneously generates a Repeated START condition (see [Figure 162](#)). Until this occurs, arbitration is not lost by either master since they were both transmitting the same data.

If the I²C hardware detects a Repeated START condition on the I²C-bus before generating a Repeated START condition itself, it will release the bus, and no interrupt request is generated. If another master frees the bus by generating a STOP condition, the I²C block will transmit a normal START condition (state 0x08), and a retry of the total serial data transfer can commence.

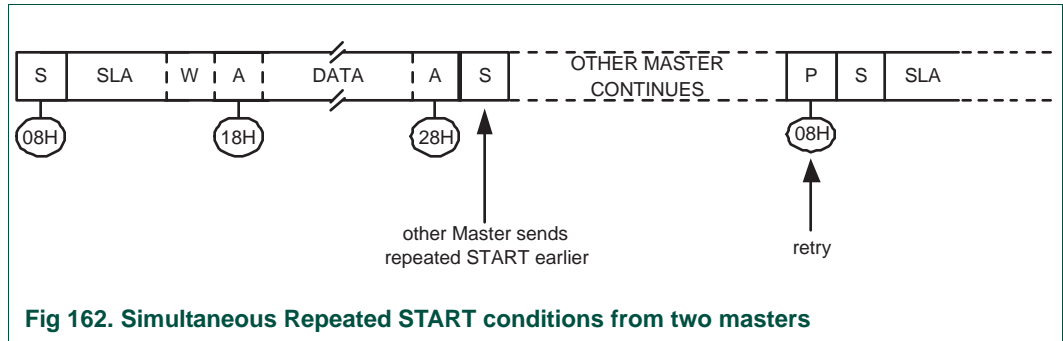

42.10.6.2 Data transfer after loss of arbitration

Arbitration may be lost in the master transmitter and master receiver modes (see [Figure 156](#)). Loss of arbitration is indicated by the following states in STAT; 0x38, 0x68, 0x78, and 0xB0 (see [Figure 158](#) and [Figure 159](#)).

If the STA flag in CON is set by the routines which service these states, then, if the bus is free again, a START condition (state 0x08) is transmitted without intervention by the CPU, and a retry of the total serial transfer can commence.

42.10.6.3 Forced access to the I²C-bus

In some applications, it may be possible for an uncontrolled source to cause a bus hang-up. In such situations, the problem may be caused by interference, temporary interruption of the bus or a temporary short-circuit between SDA and SCL.

If an uncontrolled source generates a superfluous START or masks a STOP condition, then the I²C-bus stays busy indefinitely. If the STA flag is set and bus access is not obtained within a reasonable amount of time, then a forced access to the I²C-bus is possible. This is achieved by setting the STO flag while the STA flag is still set. No STOP condition is transmitted. The I²C hardware behaves as if a STOP condition was received and is able to transmit a START condition. The STO flag is cleared by hardware (see [Figure 163](#)).

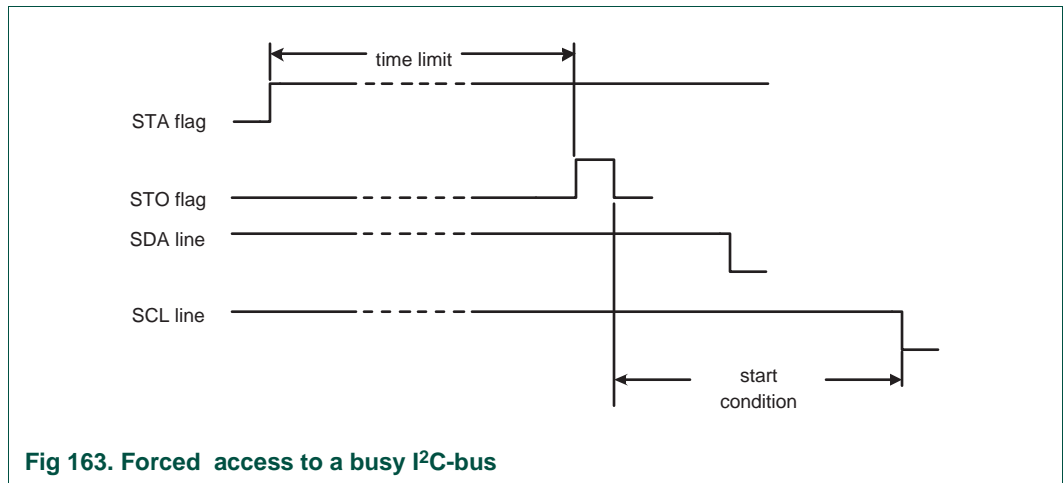

42.10.8 Initialization

In the initialization example, the I²C block is enabled for both master and slave modes. For each mode, a buffer is used for transmission and reception. The initialization routine performs the following functions:

- I2ADR is loaded with the part's own slave address and the General Call bit (GC)
- The I²C interrupt enable and interrupt priority bits are set
- The slave mode is enabled by simultaneously setting the I2EN and AA bits in CON and the serial clock frequency (for master modes) is defined by loading the SCLH and SCLL registers. The master routines must be started in the main program.

The I²C hardware now begins checking the I²C-bus for its own slave address and General Call. If the General Call or the own slave address is detected, an interrupt is requested and STAT is loaded with the appropriate state information.

42.10.9 I²C interrupt service

When the I²C interrupt is entered, STAT contains a status code which identifies one of the 26 state services to be executed.

42.10.10 The state service routines

Each state routine is part of the I²C interrupt routine and handles one of the 26 states.

42.10.11 Adapting state services to an application

The state service examples show the typical actions that must be performed in response to the 26 I²C state codes. If one or more of the four I²C operating modes are not used, the associated state services can be omitted, as long as care is taken that those states can never occur.

In an application, it may be desirable to implement some kind of time-out during I²C operations, in order to trap an inoperative bus or a lost service routine.

42.11 Software example

42.11.1 Initialization routine

Example to initialize I²C Interface as a Slave and/or Master.

1. Load ADR with own Slave Address, enable General Call recognition if needed.
2. Enable I²C interrupt.
3. Write 0x44 to CONSET to set the I2EN and AA bits, enabling Slave functions. For Master only functions, write 0x40 to CONSET.

42.11.2 Start Master Transmit function

Begin a Master Transmit operation by setting up the buffer, pointer, and data count, then initiating a START.

1. Initialize Master data counter.

2. Set up the Slave Address to which data will be transmitted, and add the Write bit.
3. Write 0x20 to CONSET to set the STA bit.
4. Set up data to be transmitted in Master Transmit buffer.
5. Initialize the Master data counter to match the length of the message being sent.
6. Exit

42.11.3 Start Master Receive function

Begin a Master Receive operation by setting up the buffer, pointer, and data count, then initiating a START.

1. Initialize Master data counter.
2. Set up the Slave Address to which data will be transmitted, and add the Read bit.
3. Write 0x20 to CONSET to set the STA bit.
4. Set up the Master Receive buffer.
5. Initialize the Master data counter to match the length of the message to be received.
6. Exit

42.11.4 I²C interrupt routine

Determine the I²C state and which state routine will be used to handle it.

1. Read the I²C status from STA.
2. Use the status value to branch to one of 26 possible state routines.

42.11.5 Non mode specific states

42.11.5.1 State: 0x00

Bus Error. Enter not addressed Slave mode and release bus.

1. Write 0x14 to CONSET to set the STO and AA bits.
2. Write 0x08 to CONCLR to clear the SI flag.
3. Exit

42.11.5.2 Master States

State 08 and State 10 are for both Master Transmit and Master Receive modes. The R/W bit decides whether the next state is within Master Transmit mode or Master Receive mode.

42.11.5.3 State: 0x08

A START condition has been transmitted. The Slave Address + R/W bit will be transmitted, an ACK bit will be received.

1. Write Slave Address with R/W bit to DAT.
2. Write 0x04 to CONSET to set the AA bit.
3. Write 0x08 to CONCLR to clear the SI flag.
4. Set up Master Transmit mode data buffer.

5. Set up Master Receive mode data buffer.
6. Initialize Master data counter.
7. Exit

42.11.5.4 State: 0x10

A Repeated START condition has been transmitted. The Slave Address + R/W bit will be transmitted, an ACK bit will be received.

1. Write Slave Address with R/W bit to DAT.
2. Write 0x04 to CONSET to set the AA bit.
3. Write 0x08 to CONCLR to clear the SI flag.
4. Set up Master Transmit mode data buffer.
5. Set up Master Receive mode data buffer.
6. Initialize Master data counter.
7. Exit

42.11.6 Master Transmitter states

42.11.6.1 State: 0x18

Previous state was State 8 or State 10, Slave Address + Write has been transmitted, ACK has been received. The first data byte will be transmitted, an ACK bit will be received.

1. Load DAT with first data byte from Master Transmit buffer.
2. Write 0x04 to CONSET to set the AA bit.
3. Write 0x08 to CONCLR to clear the SI flag.
4. Increment Master Transmit buffer pointer.
5. Exit

42.11.6.2 State: 0x20

Slave Address + Write has been transmitted, NOT ACK has been received. A STOP condition will be transmitted.

1. Write 0x14 to CONSET to set the STO and AA bits.
2. Write 0x08 to CONCLR to clear the SI flag.
3. Exit

42.11.6.3 State: 0x28

Data has been transmitted, ACK has been received. If the transmitted data was the last data byte then transmit a STOP condition, otherwise transmit the next data byte.

1. Decrement the Master data counter, skip to step 5 if not the last data byte.
2. Write 0x14 to CONSET to set the STO and AA bits.
3. Write 0x08 to CONCLR to clear the SI flag.
4. Exit
5. Load DAT with next data byte from Master Transmit buffer.

6. Write 0x04 to CONSET to set the AA bit.
7. Write 0x08 to CONCLR to clear the SI flag.
8. Increment Master Transmit buffer pointer
9. Exit

42.11.6.4 State: 0x30

Data has been transmitted, NOT ACK received. A STOP condition will be transmitted.

1. Write 0x14 to CONSET to set the STO and AA bits.
2. Write 0x08 to CONCLR to clear the SI flag.
3. Exit

42.11.6.5 State: 0x38

Arbitration has been lost during Slave Address + Write or data. The bus has been released and not addressed Slave mode is entered. A new START condition will be transmitted when the bus is free again.

1. Write 0x24 to CONSET to set the STA and AA bits.
2. Write 0x08 to CONCLR to clear the SI flag.
3. Exit

42.11.7 Master Receive states

42.11.7.1 State: 0x40

Previous state was State 08 or State 10. Slave Address + Read has been transmitted, ACK has been received. Data will be received and ACK returned.

1. Write 0x04 to CONSET to set the AA bit.
2. Write 0x08 to CONCLR to clear the SI flag.
3. Exit

42.11.7.2 State: 0x48

Slave Address + Read has been transmitted, NOT ACK has been received. A STOP condition will be transmitted.

1. Write 0x14 to CONSET to set the STO and AA bits.
2. Write 0x08 to CONCLR to clear the SI flag.
3. Exit

42.11.7.3 State: 0x50

Data has been received, ACK has been returned. Data will be read from DAT. Additional data will be received. If this is the last data byte then NOT ACK will be returned, otherwise ACK will be returned.

1. Read data byte from DAT into Master Receive buffer.
2. Decrement the Master data counter, skip to step 5 if not the last data byte.
3. Write 0x0C to CONCLR to clear the SI flag and the AA bit.

4. Exit
5. Write 0x04 to CONSET to set the AA bit.
6. Write 0x08 to CONCLR to clear the SI flag.
7. Increment Master Receive buffer pointer
8. Exit

42.11.7.4 State: 0x58

Data has been received, NOT ACK has been returned. Data will be read from DAT. A STOP condition will be transmitted.

1. Read data byte from DAT into Master Receive buffer.
2. Write 0x14 to CONSET to set the STO and AA bits.
3. Write 0x08 to CONCLR to clear the SI flag.
4. Exit

42.11.8 Slave Receiver states

42.11.8.1 State: 0x60

Own Slave Address + Write has been received, ACK has been returned. Data will be received and ACK returned.

1. Write 0x04 to CONSET to set the AA bit.
2. Write 0x08 to CONCLR to clear the SI flag.
3. Set up Slave Receive mode data buffer.
4. Initialize Slave data counter.
5. Exit

42.11.8.2 State: 0x68

Arbitration has been lost in Slave Address and R/W bit as bus Master. Own Slave Address + Write has been received, ACK has been returned. Data will be received and ACK will be returned. STA is set to restart Master mode after the bus is free again.

1. Write 0x24 to CONSET to set the STA and AA bits.
2. Write 0x08 to CONCLR to clear the SI flag.
3. Set up Slave Receive mode data buffer.
4. Initialize Slave data counter.
5. Exit.

42.11.8.3 State: 0x70

General call has been received, ACK has been returned. Data will be received and ACK returned.

1. Write 0x04 to CONSET to set the AA bit.
2. Write 0x08 to CONCLR to clear the SI flag.
3. Set up Slave Receive mode data buffer.

4. Initialize Slave data counter.
5. Exit

42.11.8.4 State: 0x78

Arbitration has been lost in Slave Address + R/W bit as bus Master. General call has been received and ACK has been returned. Data will be received and ACK returned. STA is set to restart Master mode after the bus is free again.

1. Write 0x24 to CONSET to set the STA and AA bits.
2. Write 0x08 to CONCLR to clear the SI flag.
3. Set up Slave Receive mode data buffer.
4. Initialize Slave data counter.
5. Exit

42.11.8.5 State: 0x80

Previously addressed with own Slave Address. Data has been received and ACK has been returned. Additional data will be read.

1. Read data byte from DAT into the Slave Receive buffer.
2. Decrement the Slave data counter, skip to step 5 if not the last data byte.
3. Write 0x0C to CONCLR to clear the SI flag and the AA bit.
4. Exit.
5. Write 0x04 to CONSET to set the AA bit.
6. Write 0x08 to CONCLR to clear the SI flag.
7. Increment Slave Receive buffer pointer.
8. Exit

42.11.8.6 State: 0x88

Previously addressed with own Slave Address. Data has been received and NOT ACK has been returned. Received data will not be saved. Not addressed Slave mode is entered.

1. Write 0x04 to CONSET to set the AA bit.
2. Write 0x08 to CONCLR to clear the SI flag.
3. Exit

42.11.8.7 State: 0x90

Previously addressed with General Call. Data has been received, ACK has been returned. Received data will be saved. Only the first data byte will be received with ACK. Additional data will be received with NOT ACK.

1. Read data byte from DAT into the Slave Receive buffer.
2. Write 0x0C to CONCLR to clear the SI flag and the AA bit.
3. Exit

42.11.8.8 State: 0x98

Previously addressed with General Call. Data has been received, NOT ACK has been returned. Received data will not be saved. Not addressed Slave mode is entered.

1. Write 0x04 to CONSET to set the AA bit.
2. Write 0x08 to CONCLR to clear the SI flag.
3. Exit

42.11.8.9 State: 0xA0

A STOP condition or Repeated START has been received, while still addressed as a Slave. Data will not be saved. Not addressed Slave mode is entered.

1. Write 0x04 to CONSET to set the AA bit.
2. Write 0x08 to CONCLR to clear the SI flag.
3. Exit

42.11.9 Slave Transmitter states**42.11.9.1 State: 0xA8**

Own Slave Address + Read has been received, ACK has been returned. Data will be transmitted, ACK bit will be received.

1. Load DAT from Slave Transmit buffer with first data byte.
2. Write 0x04 to CONSET to set the AA bit.
3. Write 0x08 to CONCLR to clear the SI flag.
4. Set up Slave Transmit mode data buffer.
5. Increment Slave Transmit buffer pointer.
6. Exit

42.11.9.2 State: 0xB0

Arbitration lost in Slave Address and R/W bit as bus Master. Own Slave Address + Read has been received, ACK has been returned. Data will be transmitted, ACK bit will be received. STA is set to restart Master mode after the bus is free again.

1. Load DAT from Slave Transmit buffer with first data byte.
2. Write 0x24 to CONSET to set the STA and AA bits.
3. Write 0x08 to CONCLR to clear the SI flag.
4. Set up Slave Transmit mode data buffer.
5. Increment Slave Transmit buffer pointer.
6. Exit

42.11.9.3 State: 0xB8

Data has been transmitted, ACK has been received. Data will be transmitted, ACK bit will be received.

1. Load DAT from Slave Transmit buffer with data byte.

2. Write 0x04 to CONSET to set the AA bit.
3. Write 0x08 to CONCLR to clear the SI flag.
4. Increment Slave Transmit buffer pointer.
5. Exit

42.11.9.4 State: 0xC0

Data has been transmitted, NOT ACK has been received. Not addressed Slave mode is entered.

1. Write 0x04 to CONSET to set the AA bit.
2. Write 0x08 to CONCLR to clear the SI flag.
3. Exit.

42.11.9.5 State: 0xC8

The last data byte has been transmitted, ACK has been received. Not addressed Slave mode is entered.

1. Write 0x04 to CONSET to set the AA bit.
2. Write 0x08 to CONCLR to clear the SI flag.
3. Exit

43.1 How to read this chapter

The C_CAN0/1 controllers are available on all LPC18xx parts.

43.2 Basic configuration

The C_CAN is configured as follows:

- See [Table 969](#) for clocking and power control.
- The C_CAN0 is reset by the CAN0_RST (reset # 55).
- The C_CAN1 is reset by the CAN1_RST (reset # 56).
- The ORed C_CAN0 and C_CAN1 interrupt is connected to slot # 12 in the Event router.
- The C_CAN0 interrupt is connected to interrupt #51 in the NVIC.
- The C_CAN1 interrupt is connected to interrupt #43 in the NVIC.
- Set the CAN clock divider CLKDIV to divide the CLK_APB3_CAN0 and CLK_APB1_CAN1 clocks to run at less than 50 MHz. See [Table 1014](#).
- See [Section 43.7.5.1.1](#) for calculating the CAN bit rate.

Table 969. C_CAN clocking and power control

	Base clock	Branch clock	Operating frequency
Clock to the C_CAN0 register interface and C_CAN0 peripheral clock (PCLK). PCLK must be divided by the CAN0 clock divider CLKDIV to be less than 50 MHz.	BASE_APB3_CLK	CLK_APB3_CAN0	up to 180 MHz
Clock to the C_CAN1 register interface and C_CAN1 peripheral clock (PCLK). PCLK must be divided by the CAN1 clock divider CLKDIV to be less than 50 MHz.	BASE_APB1_CLK	CLK_APB1_CAN1	up to 180 MHz

Remark: The clocks to the C_CAN0 and C_CAN1 interfaces can be set independently of each other.

Remark: Use of C_CAN controller excludes operation of all other peripherals connected to the same bus bridge. See the *LPC18xx errata*.

43.3 Features

- Conforms to protocol version 2.0 parts A and B.
- Supports bit rate of up to 1 Mbit/s.
- Supports 32 Message Objects.
- Each Message Object has its own identifier mask.

- Provides programmable FIFO mode (concatenation of Message Objects).
- Provides maskable interrupts.
- Supports Disabled Automatic Retransmission (DAR) mode for time-triggered CAN applications.
- Provides programmable loop-back mode for self-test operation.

43.4 General description

Controller Area Network (CAN) is the definition of a high performance communication protocol for serial data communication. The C_CAN controller is designed to provide a full implementation of the CAN protocol according to the CAN Specification Version 2.0B. The C_CAN controller allows to build powerful local networks with low-cost multiplex wiring by supporting distributed real-time control with a very high level of security.

The CAN controller consists of a CAN core, message RAM, a message handler, control registers, and the APB interface.

For communication on a CAN network, individual Message Objects are configured. The Message Objects and Identifier Masks for acceptance filtering of received messages are stored in the Message RAM.

All functions concerning the handling of messages are implemented in the Message Handler. Those functions are the acceptance filtering, the transfer of messages between the CAN Core and the Message RAM, and the handling of transmission requests as well as the generation of the module interrupt.

The register set of the CAN controller can be accessed directly by the CPU via the APB bus. These registers are used to control/configure the CAN Core and the Message Handler and to access the Message RAM.

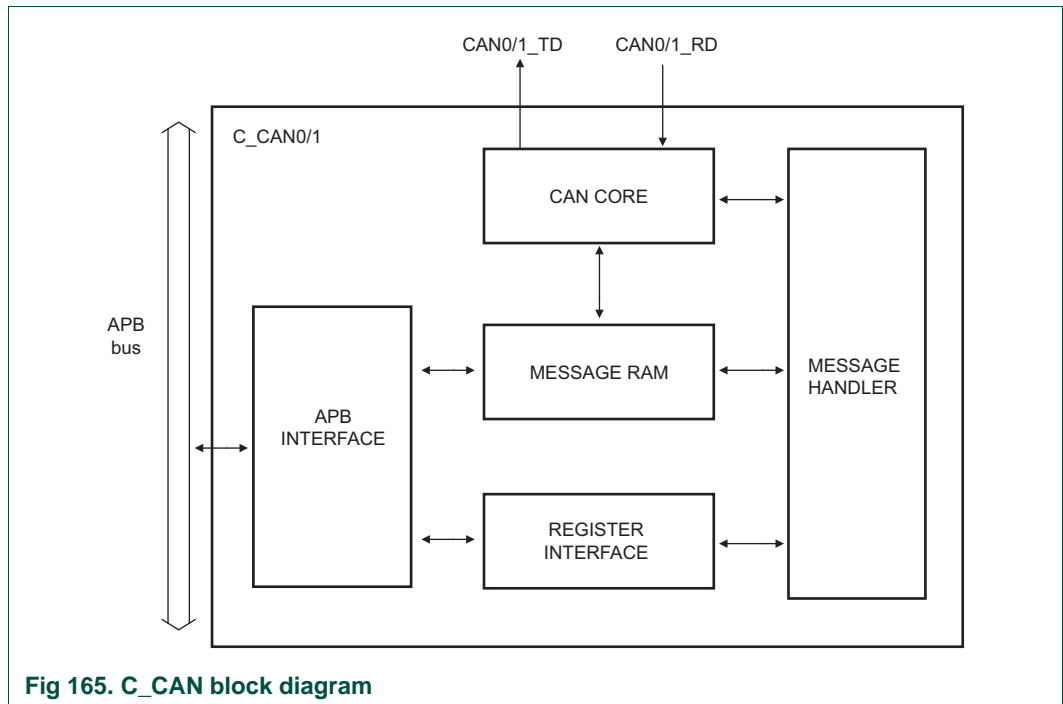

Fig 165. C_CAN block diagram

43.5 Pin description

Table 970. C_CAN pin description

Pin function	Direction	Description
CAN0/1_RD	I	C_CAN receive input
CAN0/1_TD	O	C_CAN transmit output

43.6 Register description

Register values at reset

After a hardware reset, the registers hold the values described in [Table 971](#). Additionally, the busoff state is reset and the output TD0,1 is set to recessive (HIGH). The value 0x0001 (INIT = '1') in the CAN Control Register enables the software initialization. The CAN controller does not communicate with the CAN bus until the CPU resets INIT to '0'.

The data stored in the message RAM is not affected by a hardware reset. After power-on, the contents of the message RAM is undefined.

Table 971. Register overview: C_CAN0 (base address 0x400E 2000)

Name	Access	Address offset	Description	Reset value	Reference
CNTL	R/W	0x000	CAN control register	0x0001	Table 973
STAT	R/W	0x004	Status register	0x0000	Table 974
EC	RO	0x008	Error counter register	0x0000	Table 975
BT		0x00C	Bit timing register	0x2301	Table 976
INT	RO	0x010	Interrupt register	0x0000	Table 977
TEST	R/W	0x014	Test register	-	Table 978
BRPE	R/W	0x018	Baud rate prescaler extension register	0x0000	Table 979
-	-	0x01C	Reserved	-	
IF1_CMDREQ	R/W	0x020	Message interface 1 command request	0x0001	Table 982
IF1_CMDMSK_W	R/W	0x024	Message interface 1 command mask (write direction)	0x0000	Table 984
IF1_CMDMSK_R	R/W	0x024	Message interface 1 command mask (read direction)	0x0000	Table 986
IF1_MSK1	R/W	0x028	Message interface 1 mask 1	0xFFFF	Table 988
IF1_MSK2	R/W	0x02C	Message interface 1 mask 2	0xFFFF	Table 990
IF1_ARB1	R/W	0x030	Message interface 1 arbitration 1	0x0000	Table 992
IF1_ARB2	R/W	0x034	Message interface 1 arbitration 2	0x0000	Table 994
IF1_MCTRL	R/W	0x038	Message interface 1 message control	0x0000	Table 996
IF1_DA1	R/W	0x03C	Message interface 1 data A1	0x0000	Table 998
IF1_DA2	R/W	0x040	Message interface 1 data A2	0x0000	Table 999
IF1_DB1	R/W	0x044	Message interface 1 data B1	0x0000	Table 1002
IF1_DB2	R/W	0x048	Message interface 1 data B2	0x0000	Table 1004
-		0x04C - 0x07C	Reserved	-	
IF2_CMDREQ	R/W	0x080	Message interface 2 command request	0x0001	Table 983
IF2_CMDMSK_W	R/W	0x084	Message interface 2 command mask (write direction)	0x0000	Table 985
IF2_CMDMSK_R	R/W	0x084	Message interface 2 command mask (read direction)	0x0000	Table 987
IF2_MSK1	R/W	0x088	Message interface 2 mask 1	0xFFFF	Table 989
IF2_MSK2	R/W	0x08C	Message interface 2 mask 2	0xFFFF	Table 991
IF2_ARB1	R/W	0x090	Message interface 2 arbitration 1	0x0000	Table 993

Table 971. Register overview: C_CAN0 (base address 0x400E 2000)

Name	Access	Address offset	Description	Reset value	Reference
IF2_ARB2	R/W	0x094	Message interface 2 arbitration 2	0x0000	Table 995
IF2_MCTRL	R/W	0x098	Message interface 2 message control	0x0000	Table 997
IF2_DA1	R/W	0x09C	Message interface 2 data A1	0x0000	Table 999
IF2_DA2	R/W	0x0A0	Message interface 2 data A2	0x0000	Table 1000
IF2_DB1	R/W	0x0A4	Message interface 2 data B1	0x0000	Table 1003
IF2_DB2	R/W	0x0A8	Message interface 2 data B2	0x0000	Table 1005
-	-	0x0AC - 0x0FC			
TXREQ1	RO	0x100	Transmission request 1	0x0000	Table 1006
TXREQ2	RO	0x104	Transmission request 2	0x0000	Table 1007
-	-	0x108 - 0x11C	Reserved	-	
ND1	RO	0x120	New data 1	0x0000	Table 1008
ND2	RO	0x124	New data 2	0x0000	Table 1009
-	-	0x128 - 0x13C	Reserved	-	
IR1	RO	0x140	Interrupt pending 1	0x0000	Table 1010
IR2	RO	0x144	Interrupt pending 2	0x0000	Table 1011
-	-	0x148 - 0x15C	Reserved	-	
MSGV1	RO	0x160	Message valid 1	0x0000	Table 1012
MSGV2	RO	0x164	Message valid 2	0x0000	Table 1013
-	-	0x168 - 0x17C	Reserved	-	
CLKDIV	R/W	0x180	CAN clock divider register	0x0001	Table 1014

Table 972. Register overview: C_CAN1 (base address 0x400A 4000)

Name	Access	Address offset	Description	Reset value	Reference
CNTL	R/W	0x000	CAN control	0x0001	Table 973
STAT	R/W	0x004	Status register	0x0000	Table 974
EC	RO	0x008	Error counter	0x0000	Table 975
BT		0x00C	Bit timing register	0x2301	Table 976
INT	RO	0x010	Interrupt register	0x0000	Table 977
TEST	R/W	0x014	Test register	-	Table 978
BRPE	R/W	0x018	Baud rate prescaler extension register	0x0000	Table 979
-	-	0x01C	Reserved	-	
IF1_CMDREQ	R/W	0x020	Message interface 1 command request	0x0001	Table 982
IF1_CMDMSK_W	R/W	0x024	Message interface 1 command mask (write direction)	0x0000	Table 984
IF1_CMDMSK_R	R/W	0x024	Message interface 1 command mask (read direction)	0x0000	Table 986

Table 972. Register overview: C_CAN1 (base address 0x400A 4000)

Name	Access	Address offset	Description	Reset value	Reference
IF1_MSK1	R/W	0x028	Message interface 1 mask 1	0xFFFF	Table 988
IF1_MSK2	R/W	0x02C	Message interface 1 mask 2	0xFFFF	Table 990
IF1_ARB1	R/W	0x030	Message interface 1 arbitration 1	0x0000	Table 992
IF1_ARB2	R/W	0x034	Message interface 1 arbitration 2	0x0000	Table 994
IF1_MCTRL	R/W	0x038	Message interface 1 message control	0x0000	Table 996
IF1_DA1	R/W	0x03C	Message interface 1 data A1	0x0000	Table 998
IF1_DA2	R/W	0x040	Message interface 1 data A2	0x0000	Table 999
IF1_DB1	R/W	0x044	Message interface 1 data B1	0x0000	Table 1002
IF1_DB2	R/W	0x048	Message interface 1 data B2	0x0000	Table 1004
-	-	0x04C - 0x07C	Reserved	-	
IF2_CMDREQ	R/W	0x080	Message interface 2 command request	0x0001	Table 983
IF2_CMDMSK_W	R/W	0x084	Message interface 2 command mask (write direction)	0x0000	Table 985
IF2_CMDMSK_R	R/W	0x084	Message interface 2 command mask (read direction)	0x0000	Table 987
IF2_MSK1	R/W	0x088	Message interface 2 mask 1	0xFFFF	Table 989
IF2_MSK2	R/W	0x08C	Message interface 2 mask 2	0xFFFF	Table 991
IF2_ARB1	R/W	0x090	Message interface 2 arbitration 1	0x0000	Table 993
IF2_ARB2	R/W	0x094	Message interface 2 arbitration 2	0x0000	Table 995
IF2_MCTRL	R/W	0x098	Message interface 2 message control	0x0000	Table 997
IF2_DA1	R/W	0x09C	Message interface 2 data A1	0x0000	Table 999
IF2_DA2	R/W	0x0A0	Message interface 2 data A2	0x0000	Table 1000
IF2_DB1	R/W	0x0A4	Message interface 2 data B1	0x0000	Table 1003
IF2_DB2	R/W	0x0A8	Message interface 2 data B2	0x0000	Table 1005
-	-	0x0AC - 0x0FC			
TXREQ1	RO	0x100	Transmission request 1	0x0000	Table 1006
TXREQ2	RO	0x104	Transmission request 2	0x0000	Table 1007
-	-	0x108 - 0x11C	Reserved	-	
ND1	RO	0x120	New data 1	0x0000	Table 1008
ND2	RO	0x124	New data 2	0x0000	Table 1009
-	-	0x128 - 0x13C	Reserved	-	
IR1	RO	0x140	Interrupt pending 1	0x0000	Table 1010
IR2	RO	0x144	Interrupt pending 2	0x0000	Table 1011
-	-	0x148 - 0x15C	Reserved	-	
MSGV1	RO	0x160	Message valid 1	0x0000	Table 1012

Table 972. Register overview: C_CAN1 (base address 0x400A 4000)

Name	Access	Address offset	Description	Reset value	Reference
MSGV2	RO	0x164	Message valid 2	0x0000	Table 1013
-	-	0x168 - 0x17C	Reserved	-	
CLKDIV	R/W	0x180	CAN clock divider register	0x0001	Table 1014

43.6.1 CAN protocol registers

43.6.1.1 CAN control register

After a hardware reset, the registers of the C_CAN controller hold the values described in [Table 971](#). Additionally, the busoff state is set, and the TD0/1 outputs are set to HIGH. The reset value 0x0001 of the CANCTRL register enables initialization by software (INIT = 1). The C_CAN does not influence the CAN bus until the CPU resets the INIT bit to 0.

Table 973. CAN control registers (CNTL, address 0x400E 2000 (C_CAN0) and 0x400A 4000 (C_CAN1)) bit description

Bit	Symbol	Value	Description	Reset value	Access
0	INIT		Initialization	1	R/W
		0	Normal operation.		
		1	Initialization is started. On reset, software needs to initialize the CAN controller.		
1	IE		Module interrupt enable	0	R/W
		0	Disable CAN interrupts. The interrupt line is always HIGH.		
		1	Enable CAN interrupts. The interrupt line is set to LOW and remains LOW until all pending interrupts are cleared.		
2	SIE		Status change interrupt enable	0	R/W
		0	Disable status change interrupts. No status change interrupt will be generated.		
		1	Enable status change interrupts. A status change interrupt will be generated when a message transfer is successfully completed or a CAN bus error is detected.		
3	EIE		Error interrupt enable	0	R/W
		0	Disable error interrupt. No error status interrupt will be generated.		
		1	Enable error interrupt. A change in the bits BOFF or EWARN in the CANSTAT registers will generate an interrupt.		
4	-	-	Reserved	0	-
5	DAR		Disable automatic retransmission	0	R/W
		0	Automatic retransmission of disturbed messages enabled.		
		1	Automatic retransmission disabled.		

Table 973. CAN control registers (CNTL, address 0x400E 2000 (C_CAN0) and 0x400A 4000 (C_CAN1)) bit description

...continued

Bit	Symbol	Value	Description	Reset value	Access
6	CCE		Configuration change enable	0	R/W
		0	The CPU has no write access to the bit timing register.		
		1	The CPU has write access to the CANBT register while the INIT bit is one.		
7	TEST		Test mode enable	0	R/W
		0	Normal operation.		
		1	Test mode.		
31:8	-		reserved	-	-

Remark: The busoff recovery sequence (see *CAN Specification Rev. 2.0*) cannot be shortened by setting or resetting the INIT bit. If the device goes into busoff state, it will set INIT, stopping all bus activities. Once INIT has been cleared by the CPU, the device will then wait for 129 occurrences of Bus Idle (129×11 consecutive HIGH/recessive bits) before resuming normal operations. At the end of the busoff recovery sequence, the Error Management Counters will be reset.

During the waiting time after the resetting of INIT, each time a sequence of 11 HIGH/recessive bits has been monitored, a Bit0Error code is written to the Status Register CANSTAT, enabling the CPU to monitor the proceeding of the busoff recovery sequence and to determine whether the CAN bus is stuck at LOW/dominant or continuously disturbed.

43.6.1.2 CAN status register

Table 974. CAN status register (STAT, address 0x400E 2004 (C_CAN0) and 0x400A 4004 (C_CAN1)) bit description

Bit	Symbol	Value	Description	Reset value	Access
2:0	LEC		Last error code	000	R/W
			Type of the last error to occur on the CAN bus. The LEC field holds a code which indicates the type of the last error to occur on the CAN bus. This field will be cleared to '0' when a message has been transferred (reception or transmission) without error. The unused code '111' may be written by the CPU to check for updates.		
		0x0	No error.		
		0x1	Stuff error: More than 5 equal bits in a sequence have occurred in a part of a received message where this is not allowed.		
		0x2	Form error: A fixed format part of a received frame has the wrong format.		
		0x3	AckError: The message this CAN core transmitted was not acknowledged.		
		0x4	Bit1Error: During the transmission of a message (with the exception of the arbitration field), the device wanted to send a HIGH/recessive level (bit of logical value '1'), but the monitored bus value was LOW/dominant.		
		0x5	Bit0Error: During the transmission of a message (or acknowledge bit, or active error flag, or overload flag), the device wanted to send a LOW/dominant level (data or identifier bit logical value '0'), but the monitored Bus value was HIGH/recessive. During busoff recovery this status is set each time a sequence of 11 HIGH/recessive bits has been monitored. This enables the CPU to monitor the proceeding of the busoff recovery sequence (indicating the bus is not stuck at LOW/dominant or continuously disturbed).		
	0x6	CRCErrror: The CRC checksum was incorrect in the message received.			
	0x7	Unused: No CAN bus event was detected (written by the CPU).			
3	TXOK		Transmitted a message successfully	0	R/W
			The CPU must reset this bit. It is never reset by the CAN controller.		
		0	Since this bit was last reset by the CPU, no message has been successfully transmitted.		
	1	Since this bit was last reset by the CPU, a message has been successfully transmitted (error free and acknowledged by at least one other node).			
4	RXOK		Received a message successfully	0	R/W
			The CPU must reset this bit. It is never reset by the CAN controller.		
		0	Since this bit was last reset by the CPU, no message has been successfully received.		
	1	Since this bit was last set to zero by the CPU, a message has been successfully received independent of the result of acceptance filtering.			

Table 974. CAN status register (STAT, address 0x400E 2004 (C_CAN0) and 0x400A 4004 (C_CAN1)) bit description
 ...continued

Bit	Symbol	Value	Description	Reset value	Access
5	EPASS		Error passive	0	RO
		0	The CAN controller is in the error active state.		
		1	The CAN controller is in the error passive state as defined in the <i>CAN 2.0 specification</i> .		
6	EWARN		Warning status	0	RO
		0	Both error counters are below the error warning limit of 96.		
		1	At least one of the error counters in the EC has reached the error warning limit of 96.		
7	BOFF		Busoff status	0	RO
		0	The CAN module is not in busoff state.		
		1	The CAN controller is in busoff state.		
31:8	-	-	reserved		

A status interrupt is generated by bits BOFF, EWARN, RXOK, TXOK, or LEC. BOFF and EWARN generate an error interrupt, and RXOK, TXOK, and LEC generate a status change interrupt if EIE and SIE respectively are set to enabled in the CANCTRL register.

A change of bit EPASS and a write to RXOK, TXOK, or LEC will never create a status interrupt.

Reading the CANSTAT register will clear the Status Interrupt value in the CANIR register.

43.6.1.3 CAN error counter

Table 975. CAN error counter (EC, address 0x400E 2008 (C_CAN0) and 0x400A 4008 (C_CAN1)) bit description

Bit	Symbol	Value	Description	Reset value	Access
7:0	TEC_7_0		Transmit error counter Current value of the transmit error counter (maximum value 255).	0	RO
14:8	REC_6_0		Receive error counter Current value of the receive error counter (maximum value 127).	0	RO
15	RP		Receive error passive	0	RO
		0	The receive counter is below the error passive level.		
		1	The receive counter has reached the error passive level as defined in the <i>CAN2.0 specification</i> .		
31:16	-	-	Reserved	-	-

43.6.1.4 CAN bit timing register

Table 976. CAN bit timing register (BT, address 0x400E 200C (C_CAN0) and 0x400A 400C (C_CAN1)) bit description

Bit	Symbol	Description	Reset value	Access
5:0	BRP	Baud rate prescaler The value by which the oscillator frequency is divided for generating the bit time quanta. The bit time is built up from a multiple of this quanta. Valid values for the Baud Rate Prescaler are 0 to 63[1]. Valid programmed values are 0x01 - 0x3F[1].	1	R/W
7:6	SJW	(Re)synchronization jump width Valid programmed values are 0 to 3[1].	0	R/w
11:8	TSEG1	Time segment before the sample point including propagation time segment. Valid values are 1 to 15[1].	0011	R/W
14:12	TSEG2	Time segment after the sample point Valid values are 0 to 7[1].	010	R/W
31:15	-	Reserved	-	-

[1] Hardware interprets the value programmed into these bits as the bit value + 1.

See [Section 43.7.5 “Bit timing”](#).

Remark: With a module clock CAN_CLK of 8 MHz, the reset value of 0x2301 configures the C_CAN for a bit rate of 500 kBit/s. The registers are only writable if a configuration change is enabled in CANCTRL and the controller is initialized by software (bits CCE and INIT in the CAN Control Register are set).

43.6.1.5 CAN interrupt register

Table 977. CAN interrupt register (INT, address 0x400E 2010 (C_CAN0) and 0x400A 4010 (C_CAN1)) bit description

Bit	Symbol	Description	Reset value	Access
15:0	INTID15_0	0x0000 = No interrupt is pending 0x0001 to 0x0020 = Number of message object which caused the interrupt. 0x0021 to 0x7FFF = Unused 0x8000 = Status interrupt 0x8001 to 0xFFFF = Unused	0	R
31:16	-	Reserved	-	-

If several interrupts are pending, the CAN Interrupt Register will point to the pending interrupt with the highest priority, disregarding their chronological order. An interrupt remains pending until the CPU has cleared it. If INTID is different from 0x0000 and IE is set, the interrupt line to the CPU is active. The interrupt line remains active until INTID is back to value 0x0000 (the cause of the interrupt is reset) or until IE is reset.

The Status Interrupt has the highest priority. Among the message interrupts, the Message Object' s interrupt priority decreases with increasing message number.

A message interrupt is cleared by clearing the Message Object's INTPND bit. The StatusInterrupt is cleared by reading the Status Register.

43.6.1.6 CAN test register

Write access to the Test Register is enabled by setting bit Test in the CAN Control Register.

The different test functions may be combined, but when TX[1:0] ≠ "00" is selected, the message transfer is disturbed.

Table 978. CAN test register (TEST, address 0x400E 2014 (C_CAN0) and 0x400A 4014 (C_CAN1)) bit description

Bit	Symbol	Value	Description	Reset value	Access
1:0	-	-			-
2	BASIC		Basic mode	0	R/W
		0	Basic mode disabled.		
		1	IF1 registers used as TX buffer, IF2 registers used as RX buffer.		
3	SILENT		Silent mode	0	R/W
		0	Normal operation.		
		1	The module is in silent mode.		
4	LBACK		Loop back mode	0	R/W
		0	Loop back mode is disabled.		
		1	Loop back mode is enabled.		
6:5	TX1_0		Control of TD pins	00	R/W
		0x0	Level at the TD pin is controlled by the CAN controller. This is the value at reset.		
		0x1	The sample point can be monitored at the TD pin.		
		0x2	TD pin is driven LOW/dominant.		
		0x3	TD pin is driven HIGH/recessive.		
7	RX		Monitors the actual value of the RD Pin	0	R
		0	The CAN bus is dominant (RD = 0).		
		1	The CAN bus is recessive (RD = 1).		
31:8	-		Reserved		-

43.6.1.7 CAN baud rate prescaler extension register

Table 979. CAN baud rate prescaler extension register (BRPE, address 0x400E 2018 (C_CAN0) and 0x400A 4018 (C_CAN1)) bit description

Bit	Symbol	Description	Reset value	Access
3:0	BRPE	Baud rate prescaler extension By programming BRPE the Baud Rate Prescaler can be extended to values up to 1023. Hardware interprets the value as the value of BRPE (MSBs) and BRP (LSBs) plus one. Allowed values are 0x00 to 0x0F	0x0000	R/W
31:4	-	Reserved	-	-

43.6.2 Message interface registers

There are two sets of interface registers which are used to control the CPU access to the Message RAM. The interface registers avoid conflicts between CPU access to the Message RAM and CAN message reception and transmission by buffering the data to be transferred. A complete Message Object (see [Section 43.6.2.1](#)) or parts of the Message Object may be transferred between the Message RAM and the IFx Message Buffer registers in one single transfer.

The function of the two interface register sets is identical (except for test mode Basic). One set of registers may be used for data transfer to the Message RAM while the other set of registers may be used for the data transfer from the Message RAM, allowing both processes to be interrupted by each other.

Each set of interface registers consists of message buffer registers controlled by their own command registers. The command mask register specifies the direction of the data transfer and which parts of a message object will be transferred. The command request register is used to select a message object in the message RAM as target or source for the transfer and to start the action specified in the command mask register.

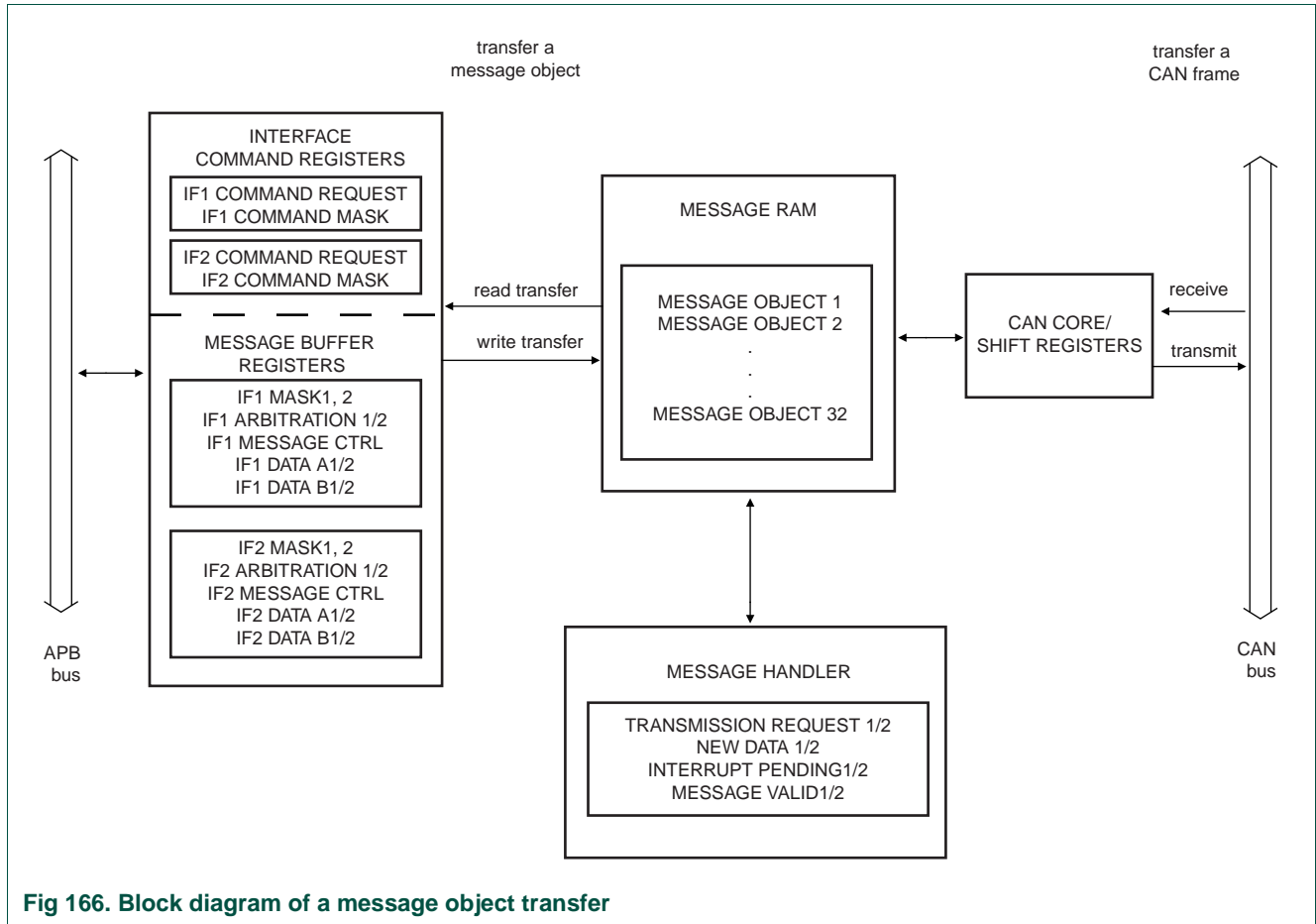

Fig 166. Block diagram of a message object transfer

Table 980. Message interface registers

IF1 register names	IF1 register set	IF2 register names	IF2 register set
IF1_CMDREQ	IF1 command request	IF2_CMDREQ	IF2 command request
IF1_CMDMASK	IF1 command mask	IF2_CMDMASK	IF2 command mask
IF1_MASK1	IF1 mask 1	IF2_MSK1	IF2 mask 1
IF1_MASK2	IF1 mask 2	IF2_MSK2	IF2 mask 2
IF1_ARB1	IF1 arbitration 1	IF2_ARB1	IF2 arbitration 1
IF1_ARB2	IF1 arbitration 2	IF2_ARB2	IF2 arbitration 2
IF1_MCTRL	IF1 message control	IF2_MCTRL	IF2 message control
IF1_DA1	IF1 data A1	IF2_DA1	IF2 data A1
IF1_DA2	IF1 data A2	IF2_DA2	IF2 data A2
IF1_DB1	IF1 data B1	IF2_DB1	IF2 data B1
IF1_DB2	IF1 data B2	IF2_DB2	IF2 data B2

There are 32 Message Objects in the Message RAM. To avoid conflicts between CPU access to the Message RAM and CAN message reception and transmission, the CPU cannot directly access the Message Objects. The message objects are accessed through the IFx Interface Registers.

43.6.2.1 Message objects

A message object contains the information from the various bits in the message interface registers. [Table 981](#) below shows a schematic representation of the structure of the message object. The bits of a message object and the respective interface register where this bit is set or cleared are shown. For bit functions see the corresponding interface register.

Table 981. Structure of a message object in the message RAM

UMASK	MSK[28:0]	MXTD	MDIR	EOB	NEWDAT	MSGLST	RXIE	TXIE	INTPND
IF1/2_MCTRL	IF1/2_MSK1/2			IF1/2_MCTRL					
RMTEN	TXRQST	MSGVAL	ID[28:0]	XTD	DIR	DLC3	DLC2	DLC1	DLC0
IF1/2_MCTRL	IF1/2_ARB1/2				IF1/2_MCTRL				
DATA0	DATA1	DATA2	DATA3	DATA4	DATA5	DATA6	DATA7		
IF1/2_DA1	IF1/2_DA2		IF1/2_DB1			IF1/2_DB2			

43.6.2.2 CAN message interface command request registers

A message transfer is started as soon as the CPU has written the message number to the Command Request Register. With this write operation the BUSY bit is automatically set to '1' and the signal CAN_WAIT_B is pulled LOW) to notify the CPU that a transfer is in progress. After a wait time of 3 to 6 CAN_CLK periods, the transfer between the Interface Register and the Message RAM has completed. The BUSY bit is set back to zero and the signal CAN_WAIT_B is set back).

Table 982. CAN message interface command request registers (IF1_CMDREQ, address 0x400E 2020 (C_CAN0) and 0x400A 4020 (C_CAN1)) bit description

Bit	Symbol	Description	Reset value	Access
5:0	Message Number	Message number 0x01 to 0x20 = Valid message numbers The message object in the message RAM is selected for data transfer. 0x00 = Not a valid message number. This value is interpreted as 0x20. ^[1] 0x21 to 0x3F = Not a valid message number. This value is interpreted as 0x01 - 0x1F. ^[1]	0x01	R/W
14:6	-	Reserved		
15	BUSY	BUSY flag Set to one by hardware when writing to this Command request register. Set to zero by hardware when read/write action to this Command request register has finished.	0	R
31:16	-	Reserved	-	-

[1] When a message number that is not valid is written into the Command request registers, the message number will be transformed into a valid value and that message object will be transferred.

Table 983. CAN message interface command request registers (IF2_CMDREQ, address 0x400E 2080 (C_CAN0) and 0x400A 4080 (C_CAN1)) bit description

Bit	Symbol	Description	Reset value	Access
5:0	Message Number	Message number 0x01 to 0x20 = Valid message numbers The message object in the message RAM is selected for data transfer. 0x00 = Not a valid message number. This value is interpreted as 0x20. ^[1] 0x21 to 0x3F = Not a valid message number. This value is interpreted as 0x01 - 0x1F. ^[1]	0x01	R/W
14:6	-	Reserved		
15	BUSY	BUSY flag Set to one by hardware when writing to this Command request register. Set to zero by hardware when read/write action to this Command request register has finished.	0	R
31:16	-	Reserved	-	-

[1] When a message number that is not valid is written into the Command request registers, the message number will be transformed into a valid value and that message object will be transferred.

43.6.2.3 CAN message interface command mask registers

The control bits of the IFx Command Mask Register specify the transfer direction and select which of the IFx Message Buffer Registers are source or target of the data transfer. The functions of the register bits depend on the transfer direction (read or write) which is selected in the WR/RD bit (bit 7) of this Command mask register.

Select the WR/RD to

one for the Write transfer direction (write to message RAM)

zero for the Read transfer direction (read from message RAM)

Transfer direction Write

Table 984. CAN message interface command mask registers write direction (IF1_CMDMSK_W, address 0x400E 2024 (C_CAN0) and 0x400A 4024 (C_CAN1)) bit description

Bit	Symbol	Value	Description	Reset value	Access
0	DATA_B		Access data bytes 4-7	0	R/W
		0	Data bytes 4-7 unchanged.		
		1	Transfer data bytes 4-7 to message object.		
1	DATA_A		Access data bytes 0-3	0	R/W
		0	Data bytes 0-3 unchanged.		
		1	Transfer data bytes 0-3 to message object.		

Table 984. CAN message interface command mask registers write direction (IF1_CMDMSK_W, address 0x400E 2024 (C_CAN0) and 0x400A 4024 (C_CAN1)) bit description ...continued

Bit	Symbol	Value	Description	Reset value	Access
2	TXRQST		Access transmission request bit	0	R/W
		0	No transmission request. TXRQSRT bit unchanged in IF1/2_MCTRL. Remark: If a transmission is requested by programming this bit, the TXRQST bit in the CANIFn_MCTRL register is ignored.		
		1	Request a transmission. Set the TXRQST bit IF1/2_MCTRL.		
3	CLRINTPND	-	This bit is ignored in the write direction.	0	R/W
4	CTRL		Access control bits	0	R/W
		0	Control bits unchanged.		
		1	Transfer control bits to message object		
5	ARB		Access arbitration bits	0	R/W
		0	Arbitration bits unchanged.		
		1	Transfer Identifier, DIR, XTD, and MSGVAL bits to message object.		
6	MASK		Access mask bits	0	R/W
		0	Mask bits unchanged.		
		1	Transfer Identifier MASK + MDIR + MXTD to message object.		
7	WR_RD	1	Write transfer Transfer data from the selected message buffer registers to the message object addressed by the command request register CANIFn_CMDREQ.	0	R/W
31:8	-	-	reserved	0	-

Table 985. CAN message interface command mask registers write direction (IF2_CMDMSK_W, address 0x400E 2084 (C_CAN0) and 0x400A 4084 (C_CAN1)) bit description

Bit	Symbol	Value	Description	Reset value	Access
0	DATA_B		Access data bytes 4-7	0	R/W
		0	Data bytes 4-7 unchanged.		
		1	Transfer data bytes 4-7 to message object.		
1	DATA_A		Access data bytes 0-3	0	R/W
		0	Data bytes 0-3 unchanged.		
		1	Transfer data bytes 0-3 to message object.		

Table 985. CAN message interface command mask registers write direction (IF2_CMDMSK_W, address 0x400E 2084 (C_CAN0) and 0x400A 4084 (C_CAN1)) bit description ...continued

Bit	Symbol	Value	Description	Reset value	Access
2	TXRQST		Access transmission request bit	0	R/W
		0	No transmission request. TXRQSRT bit unchanged in IF1/2_MCTRL.		
		1	Request a transmission. Set the TXRQST bit IF1/2_MCTRL.		
3	CLRINTPND	-	This bit is ignored in the write direction.	0	R/W
4	CTRL		Access control bits	0	R/W
		0	Control bits unchanged.		
		1	Transfer control bits to message object		
5	ARB		Access arbitration bits	0	R/W
		0	Arbitration bits unchanged.		
		1	Transfer Identifier, DIR, XTD, and MSGVAL bits to message object.		
6	MASK		Access mask bits	0	R/W
		0	Mask bits unchanged.		
		1	Transfer Identifier MASK + MDIR + MXTD to message object.		
7	WR_RD	1	Write transfer	0	R/W
			Transfer data from the selected message buffer registers to the message object addressed by the command request register CANIFn_CMDREQ.		
31:8	-	-	reserved	0	-

Transfer direction Read

Table 986. CAN message interface command mask registers read direction (IF1_CMDMSK_R, address 0x400E 2024 (C_CAN0) and 0x400A 4024 (C_CAN1)) bit description

Bit	Symbol	Value	Description	Reset value	Access
0	DATA_B		Access data bytes 4-7	0	R/W
		0	data bytes 4-7 unchanged.		
		1	Transfer data bytes 4-7 to IFx message buffer register.		
1	DATA_A		Access data bytes 0-3	0	R/W
		0	data bytes 0-3 unchanged.		
		1	Transfer data bytes 0-3 to IFx message buffer.		

Table 986. CAN message interface command mask registers read direction (IF1_CMDMSK_R, address 0x400E 2024 (C_CAN0) and 0x400A 4024 (C_CAN1)) bit description ...continued

Bit	Symbol	Value	Description	Reset value	Access
2	NEWDAT		Access new data bit	0	R/W
		0	NEWDAT bit remains unchanged.		
		1	Clear NEWDAT bit in the message object. Remark: A read access to a message object can be combined with the reset of the control bits INTPND and NEWDAT in IF1/2_MCTRL. The values of these bits transferred to the IFx Message Control Register always reflect the status before resetting these bits.		
3	CLRINTPND		Clear interrupt pending bit.	0	R/W
		0	INTPND bit remains unchanged.		
		1	Clear INTPND bit in the message object.		
4	CTRL		Access control bits	0	R/W
		0	Control bits unchanged.		
		1	Transfer control bits to IFx message buffer.		
5	ARB		Access arbitration bits	0	R/W
		0	Arbitration bits unchanged.		
		1	Transfer Identifier, DIR, XTD, and MSGVAL bits to IFx message buffer register.		
6	MASK		Access mask bits	0	R/W
		0	Mask bits unchanged.		
		1	Transfer Identifier MASK + MDIR + MXTD to IFx message buffer register.		
7	WR_RD	0	Read transfer	0	R/W
			Transfer data from the message object addressed by the command request register to the selected message buffer registers CANIFn_CMDREQ.		
31:8	-	-	reserved	0	-

Table 987. CAN message interface command mask registers read direction (IF2_CMDMSK_R, address 0x400E 2084 (C_CAN0) and 0x400A 4084 (C_CAN1)) bit description

Bit	Symbol	Value	Description	Reset value	Access
0	DATA_B		Access data bytes 4-7	0	R/W
		0	data bytes 4-7 unchanged.		
		1	Transfer data bytes 4-7 to IFx message buffer register.		
1	DATA_A		Access data bytes 0-3	0	R/W
		0	data bytes 0-3 unchanged.		
		1	Transfer data bytes 0-3 to IFx message buffer.		

Table 987. CAN message interface command mask registers read direction (IF2_CMDMSK_R, address 0x400E 2084 (C_CAN0) and 0x400A 4084 (C_CAN1)) bit description ...continued

Bit	Symbol	Value	Description	Reset value	Access
2	NEWDAT		Access new data bit	0	R/W
		0	NEWDAT bit remains unchanged.		
		1	Clear NEWDAT bit in the message object.		
3	CLRINTPND		Clear interrupt pending bit.	0	R/W
		0	INTPND bit remains unchanged.		
		1	Clear INTPND bit in the message object.		
4	CTRL		Access control bits	0	R/W
		0	Control bits unchanged.		
		1	Transfer control bits to IFx message buffer.		
5	ARB		Access arbitration bits	0	R/W
		0	Arbitration bits unchanged.		
		1	Transfer Identifier, DIR, XTD, and MSGVAL bits to IFx message buffer register.		
6	MASK		Access mask bits	0	R/W
		0	Mask bits unchanged.		
		1	Transfer Identifier MASK + MDIR + MXTD to IFx message buffer register.		
7	WR_RD	0	Read transfer	0	R/W
			Transfer data from the message object addressed by the command request register to the selected message buffer registers CANIFn_CMDREQ.		
31:8	-	-	reserved	0	-

43.6.2.4 IF1 and IF2 message buffer registers

The bits of the Message Buffer registers mirror the Message Objects in the Message RAM.

43.6.2.4.1 CAN message interface command mask 1 registers

Table 988. CAN message interface command mask 1 registers (IF1_MSK1, address 0x400E 2028 (C_CAN0) and 0x400A 4028 (C_CAN1)) bit description

Bit	Symbol	Description	Reset value	Access value
15:0	MSK15_0	Identifier mask 0 = The corresponding bit in the identifier of the message can not inhibit the match in the acceptance filtering. 1 = The corresponding identifier bit is used for acceptance filtering.	0xFFFF	R/W
31:16	-	reserved	0	-

Table 989. CAN message interface command mask 1 registers (IF2_MSK1, address 0x400E 2088 (C_CAN0) and 0x400A 4088 (C_CAN1)) bit description

Bit	Symbol	Description	Reset value	Access value
15:0	MSK15_0	Identifier mask 0 = The corresponding bit in the identifier of the message can not inhibit the match in the acceptance filtering. 1 = The corresponding identifier bit is used for acceptance filtering.	0xFFFF	R/W
31:16	-	reserved	0	-

43.6.2.4.2 CAN message interface command mask 2 registers

Table 990. CAN message interface command mask 2 registers (IF1_MSK2, address 0x400E 202C (C_CAN0) and 0x400A 402C (C_CAN1)) bit description

Bit	Symbol	Value	Description	Reset value	Access value
12:0	MSK28_16		Identifier mask 0 = The corresponding bit in the identifier of the message can not inhibit the match in the acceptance filtering. 1 = The corresponding identifier bit is used for acceptance filtering.	0xFFFF	R/W
13	-		Reserved	1	-
14	MDIR		Mask message direction	1	R/W
		0	The message direction bit (DIR) has no effect on acceptance filtering.		
		1	The message direction bit (DIR) is used for acceptance filtering.		
15	MXTD		Mask extend identifier	1	R/W
		0	The extended identifier bit (IDE) has no effect on acceptance filtering.		
		1	The extended identifier bit (IDE) is used for acceptance filtering.		
31:16	-	-	Reserved	0	-

Table 991. CAN message interface command mask 2 registers (IF2_MSK2, 0x400E 208C (C_CAN0) and 0x400A 408C (C_CAN1)) bit description

Bit	Symbol	Value	Description	Reset value	Access
12:0	MSK28_16		Identifier mask 0 = The corresponding bit in the identifier of the message can not inhibit the match in the acceptance filtering. 1 = The corresponding identifier bit is used for acceptance filtering.	0xFFF	R/W
13	-		Reserved	1	-
14	MDIR		Mask message direction	1	R/W
		0	The message direction bit (DIR) has no effect on acceptance filtering.		
		1	The message direction bit (DIR) is used for acceptance filtering.		
15	MXTD		Mask extend identifier	1	R/W
		0	The extended identifier bit (IDE) has no effect on acceptance filtering.		
		1	The extended identifier bit (IDE) is used for acceptance filtering.		
31:16	-	-	Reserved	0	-

43.6.2.4.3 CAN message interface command arbitration 1 registers

Table 992. CAN message interface command arbitration 1 registers (IF1_ARB1, address 0x400E 2030 (C_CAN0) and 0x400A 4030 (C_CAN1)) bit description

Bit	Symbol	Description	Reset value	Access
15:0	ID15_0	Message identifier 29-bit identifier ("extended frame") 11-bit identifier ("standard frame")	0x00	R/W
31:16	-	Reserved	0	-

Table 993. CAN message interface command arbitration 1 registers (IF2_ARB1, address 0x400E 2090 (C_CAN0) and 0x400A 4090 (C_CAN1)) bit description

Bit	Symbol	Description	Reset value	Access
15:0	ID15_0	Message identifier 29-bit identifier ("extended frame") 11-bit identifier ("standard frame")	0x00	R/W
31:16	-	Reserved	0	-

43.6.2.4.4 CAN message interface command arbitration 2 registers

Table 994. CAN message interface command arbitration 2 registers (IF1_ARB2, address 0x400E 2034 (C_CAN0) and 0x400A 4034 (C_CAN1)) bit description

Bit	Symbol	Value	Description	Reset value	Access
12:0	ID28_16		Message identifier 29-bit identifier ("extended frame") 11-bit identifier ("standard frame")	0x00	R/W
13	DIR		Message direction	0x00	R/W
		0	Direction = receive. On TXRQST, a Remote Frame with the identifier of this Message Object is transmitted. On reception of a Data Frame with matching identifier, that message is stored in this Message Object.		
		1	Direction = transmit. On TXRQST, the respective Message Object is transmitted as a Data Frame. On reception of a Remote Frame with matching identifier, the TXRQST bit of this Message Object is set (if RMTEN = one).		
14	XTD		Extend identifier	0x00	R/W
		0	The 11-bit standard identifier will be used for this message object.		
		1	The 29-bit extended identifier will be used for this message object.		
15	MSGVAL		Message valid	0	R/W
			Remark: The MSGVAL bit of all unused Messages Objects is reset during the initialization before bit INIT is reset in the CAN Control Register. This bit must be set to zero before the identifier ID28:0, the control bits XTD, DIR, or the Data Length Code DLC3:0 are modified, or if the Messages Object is no longer required.		
		0	The message object is ignored by the message handler.		
		1	The message object is configured and should be considered by the message handler.		
31:16	-	-	Reserved	0	-

Table 995. CAN message interface command arbitration 2 registers (IF2_ARB2, address 0x400E 2094 (C_CAN0) and 0x400A 4094 (C_CAN1)) bit description

Bit	Symbol	Value	Description	Reset value	Access
12:0	ID28_16		Message identifier 29-bit identifier ("extended frame") 11-bit identifier ("standard frame")	0x00	R/W
13	DIR		Message direction	0x00	R/W
		0	Direction = receive. On TXRQST, a Remote Frame with the identifier of this Message Object is transmitted. On reception of a Data Frame with matching identifier, that message is stored in this Message Object.		
		1	Direction = transmit. On TXRQST, the respective Message Object is transmitted as a Data Frame. On reception of a Remote Frame with matching identifier, the TXRQST bit of this Message Object is set (if RMTEN = one).		
14	XTD		Extend identifier	0x00	R/W
		0	The 11-bit standard identifier will be used for this message object.		
		1	The 29-bit extended identifier will be used for this message object.		
15	MSGVAL		Message valid	0	R/W
			Remark: The MSGVAL bit of all unused Messages Objects is reset during the initialization before bit INIT is reset in the CAN Control Register. This bit must be set to zero before the identifier ID28:0, the control bits XTD, DIR, or the Data Length Code DLC3:0 are modified, or if the Messages Object is no longer required.		
		0	The message object is ignored by the message handler.		
		1	The message object is configured and should be considered by the message handler.		
31:16	-	-	Reserved	0	-

43.6.2.4.5 CAN message interface message control registers

Table 996. CAN message interface message control registers (IF1_MCTRL, address 0x400E 2038 (C_CAN0) and 0x400A 4038 (C_CAN1)) bit description

Bit	Symbol	Value	Description	Reset value	Access
3:0	DLC3_0		Data length code Remark: The Data Length Code of a Message Object must be defined the same as in all the corresponding objects with the same identifier at other nodes. When the Message Handler stores a data frame, it will write the DLC to the value given by the received message. 0000 to 1000 = Data frame has 0 - 8 data bytes. 1001 to 1111 = Data frame has 8 data bytes.	0000	R/W
6:4	-		reserved	-	-
7	EOB		End of buffer	0	R/W
		0	Message object belongs to a FIFO buffer and is not the last message object of that FIFO buffer.		
		1	Single message object or last message object of a FIFO buffer.		
8	TXRQST		Transmit request	0	R/W
		0	This message object is not waiting for transmission.		
		1	The transmission of this message object is requested and is not yet done		
9	RMTEN		Remote enable	0	R/W
		0	At the reception of a remote frame, TXRQST is left unchanged.		
		1	At the reception of a remote frame, TXRQST is set.		
10	RXIE		Receive interrupt enable	0	R/W
		0	INTPND will be left unchanged after successful reception of a frame.		
		1	INTPND will be set after successful reception of a frame.		
11	TXIE		Transmit interrupt enable	0	R/W
		0	The INTPND bit will be left unchanged after a successful reception of a frame.		
		1	INTPND will be set after a successful reception of a frame.		
12	UMASK		Use acceptance mask	0	R/W
			Remark: If UMASK is set to 1, the message object's mask bits have to be programmed during initialization of the message object before MAGVAL is set to 1.		
		0	Mask ignored.		
		1	Use mask (MSK[28:0], MXTD, and MDIR) for acceptance filtering.		

Table 996. CAN message interface message control registers (IF1_MCTRL, address 0x400E 2038 (C_CAN0) and 0x400A 4038 (C_CAN1)) bit description ...continued

Bit	Symbol	Value	Description	Reset value	Access
13	INTPND		Interrupt pending	0	R/W
		0	This message object is not the source of an interrupt.		
		1	This message object is the source of an interrupt. The Interrupt Identifier in the Interrupt Register will point to this message object if there is no other interrupt source with higher priority.		
14	MSGLST		Message lost (only valid for message objects in the direction receive).	0	R/W
		0	No message lost since this bit was reset last by the CPU.		
		1	The Message Handler stored a new message into this object when NEWDAT was still set, the CPU has lost a message.		
15	NEWDAT		New data	0	R/W
		0	No new data has been written into the data portion of this message object by the message handler since this flag was cleared last by the CPU.		
		1	The message handler or the CPU has written new data into the data portion of this message object.		
31:16	-	-	Reserved	0	-

Table 997. CAN message interface message control registers (IF2_MCTRL, address 0x400E 2098 (C_CAN0) and 0x400A 4098 (C_CAN1)) bit description

Bit	Symbol	Value	Description	Reset value	Access
3:0	DLC3_0		Data length code Remark: The Data Length Code of a Message Object must be defined the same as in all the corresponding objects with the same identifier at other nodes. When the Message Handler stores a data frame, it will write the DLC to the value given by the received message. 0000 to 1000 = Data frame has 0 - 8 data bytes. 1001 to 1111 = Data frame has 8 data bytes.	0000	R/W
6:4	-		reserved	-	-
7	EOB		End of buffer	0	R/W
		0	Message object belongs to a FIFO buffer and is not the last message object of that FIFO buffer.		
		1	Single message object or last message object of a FIFO buffer.		

Table 997. CAN message interface message control registers (IF2_MCTRL, address 0x400E 2098 (C_CAN0) and 0x400A 4098 (C_CAN1)) bit description ...continued

Bit	Symbol	Value	Description	Reset value	Access
8	TXRQST		Transmit request	0	R/W
		0	This message object is not waiting for transmission.		
		1	The transmission of this message object is requested and is not yet done		
9	RMTEN		Remote enable	0	R/W
		0	At the reception of a remote frame, TXRQST is left unchanged.		
		1	At the reception of a remote frame, TXRQST is set.		
10	RXIE		Receive interrupt enable	0	R/W
		0	INTPND will be left unchanged after successful reception of a frame.		
		1	INTPND will be set after successful reception of a frame.		
11	TXIE		Transmit interrupt enable	0	R/W
		0	The INTPND bit will be left unchanged after a successful reception of a frame.		
		1	INTPND will be set after a successful reception of a frame.		
12	UMASK		Use acceptance mask	0	R/W
			Remark: If UMASK is set to 1, the message object's mask bits have to be programmed during initialization of the message object before MAGVAL is set to 1.		
		0	Mask ignored.		
		1	Use mask (MSK[28:0], MXTD, and MDIR) for acceptance filtering.		
13	INTPND		Interrupt pending	0	R/W
		0	This message object is not the source of an interrupt.		
		1	This message object is the source of an interrupt. The Interrupt Identifier in the Interrupt Register will point to this message object if there is no other interrupt source with higher priority.		
14	MSGLST		Message lost (only valid for message objects in the direction receive).	0	R/W
		0	No message lost since this bit was reset last by the CPU.		
		1	The Message Handler stored a new message into this object when NEWDAT was still set, the CPU has lost a message.		

Table 997. CAN message interface message control registers (IF2_MCTRL, address 0x400E 2098 (C_CAN0) and 0x400A 4098 (C_CAN1)) bit description ...continued

Bit	Symbol	Value	Description	Reset value	Access
15	NEWDAT		New data	0	R/W
		0	No new data has been written into the data portion of this message object by the message handler since this flag was cleared last by the CPU.		
		1	The message handler or the CPU has written new data into the data portion of this message object.		
31:16	-	-	Reserved	0	-

43.6.2.4.6 CAN message interface data A1 registers

In a CAN Data Frame, DATA0 is the first, DATA7 (in CAN_IF1B2 AND CAN_IF2B2) is the last byte to be transmitted or received. In CAN's serial bit stream, the MSB of each byte will be transmitted first.

Remark: Byte DATA0 is the first data byte shifted into the shift register of the CAN Core during a reception, byte DATA7 is the last. When the Message Handler stores a Data Frame, it will write all the eight data bytes into a Message Object. If the Data Length Code is less than 8, the remaining bytes of the Message Object will be overwritten by non specified values.

Table 998. CAN message interface data A1 registers (IF1_DA1, address 0x400E 203C (C_CAN0) and 0x400A 403C (C_CAN1)) bit description

Bit	Symbol	Description	Reset value	Access
7:0	DATA0	Data byte 0	0x00	R/W
15:8	DATA1	Data byte 1	0x00	R/W
31:16	-	Reserved	-	-

Table 999. CAN message interface data A1 registers (IF2_DA1, address 0x400E 209C (C_CAN0) and 0x400A 409C (C_CAN1)) bit description

Bit	Symbol	Description	Reset value	Access
7:0	DATA0	Data byte 0	0x00	R/W
15:8	DATA1	Data byte 1	0x00	R/W
31:16	-	Reserved	-	-

43.6.2.4.7 CAN message interface data A2 registers

Table 1000. CAN message interface data A2 registers (IF1_DA2, address 0x400E 2040 (C_CAN0) and 0x400A 4040 (C_CAN1)) bit description

Bit	Symbol	Description	Reset value	Access
7:0	DATA2	Data byte 2	0x00	R/W
15:8	DATA3	Data byte 3	0x00	R/W
31:16	-	Reserved	-	-

Table 1001. CAN message interface data A2 registers (IF2_DA2, address 0x400E 20A0 (C_CAN0) and 0x400A 40A0 (C_CAN1)) bit description

Bit	Symbol	Description	Reset value	Access
7:0	DATA2	Data byte 2	0x00	R/W
15:8	DATA3	Data byte 3	0x00	R/W
31:16	-	Reserved	-	-

43.6.2.4.8 CAN message interface data B1 registers

Table 1002. CAN message interface data B1 registers (IF1_DB1, address 0x400E 2044 (C_CAN0) and 0x400A 4044 (C_CAN1)) bit description

Bit	Symbol	Description	Reset value	Access
7:0	DATA4	Data byte 4	0x00	R/W
15:8	DATA5	Data byte 5	0x00	R/W
31:16	-	Reserved	-	-

Table 1003. CAN message interface data B1 registers (IF2_DB1, address 0x400E 20A4 (C_CAN0) and 0x400A 40A4 (C_CAN1)) bit description

Bit	Symbol	Description	Reset value	Access
7:0	DATA4	Data byte 4	0x00	R/W
15:8	DATA5	Data byte 5	0x00	R/W
31:16	-	Reserved	-	-

43.6.2.4.9 CAN message interface data B2 registers

Table 1004. CAN message interface data B2 registers (IF1_DB2, address 0x400E 2048 (C_CAN0) and 0x400A 4048 (C_CAN1)) bit description

Bit	Symbol	Description	Reset value	Access
7:0	DATA6	Data byte 6	0x00	R/W
15:8	DATA7	Data byte 7	0x00	R/W
31:16	-	Reserved	-	-

Table 1005. CAN message interface data B2 registers (IF2_DB2, address 0x400E 20A8 (C_CAN0) and 0x400A 40A8 (C_CAN1)) bit description

Bit	Symbol	Description	Reset value	Access
7:0	DATA6	Data byte 6	0x00	R/W
15:8	DATA7	Data byte 7	0x00	R/W
31:16	-	Reserved	-	-

43.6.3 Message handler registers

All Message Handler registers are read-only. Their contents (TXRQST, NEWDAT, INTPND, and MSGVAL bits of each Message Object and the Interrupt Identifier) is status information provided by the Message Handler FSM.

43.6.3.1 CAN transmission request 1 register

This register contains the TXRQST bits of message objects 1 to 16. By reading out the TXRQST bits, the CPU can check for which Message Object a Transmission Request is pending. The TXRQST bit of a specific Message Object can be set/reset by the CPU via the IFx Message Interface Registers or by the Message Handler after reception of a Remote Frame or after a successful transmission.

Table 1006. CAN transmission request 1 register (TXREQ1, address 0x400E 2100 (C_CAN0) and 0x400A 4100 (C_CAN1)) bit description

Bit	Symbol	Description	Reset value	Access
15:0	TXRQST16_1	Transmission request bit of message objects 16 to 1. 0 = This message object is not waiting for transmission. 1 = The transmission of this message object is requested and not yet done.	0x00	R
31:16	-	Reserved	-	-

43.6.3.2 CAN transmission request 2 register

This register contains the TXRQST bits of message objects 32 to 17. By reading out the TXRQST bits, the CPU can check for which Message Object a Transmission Request is pending. The TXRQST bit of a specific Message Object can be set/reset by the CPU via the IFx Message Interface Registers or by the Message Handler after reception of a Remote Frame or after a successful transmission.

Table 1007. CAN transmission request 2 register (TXREQ2, address 0x400E 2104 (C_CAN0) and 0x400A 4104 (C_CAN1)) bit description

Bit	Symbol	Description	Reset value	Access
15:0	TXRQST32_17	Transmission request bit of message objects 32 to 17. 0 = This message object is not waiting for transmission. 1 = The transmission of this message object is requested and not yet done.	0x00	R
31:16	-	Reserved	-	-

43.6.3.3 CAN new data 1 register

This register contains the NEWDAT bits of message objects 16 to 1. By reading out the NEWDAT bits, the CPU can check for which Message Object the data portion was updated. The NEWDAT bit of a specific Message Object can be set/reset by the CPU via the IFx Message Interface Registers or by the Message Handler after reception of a Data Frame or after a successful transmission.

Table 1008. CAN new data 1 register (ND1, address 0x400E 2120 (C_CAN0) and 0x400A 4120 (C_CAN1)) bit description

Bit	Symbol	Description	Reset value	Access
15:0	NEWDAT16_1	New data bits of message objects 16 to 1. 0 = No new data has been written into the data portion of this Message Object by the Message Handler since last time this flag was cleared by the CPU. 1 = The Message Handler or the CPU has written new data into the data portion of this Message Object.	0x00	R
31:16	-	Reserved	-	-

43.6.3.4 CAN new data 2 register

This register contains the NEWDAT bits of message objects 32 to 17. By reading out the NEWDAT bits, the CPU can check for which Message Object the data portion was updated. The NEWDAT bit of a specific Message Object can be set/reset by the CPU via the IFx Message Interface Registers or by the Message Handler after reception of a Data Frame or after a successful transmission.

Table 1009. CAN new data 2 register (ND2, address 0x400E 2124 (C_CAN0) and 0x400A 4124 (C_CAN1)) bit description

Bit	Symbol	Description	Reset value	Access
15:0	NEWDAT32_17	New data bits of message objects 32 to 17. 0 = No new data has been written into the data portion of this Message Object by the Message Handler since last time this flag was cleared by the CPU. 1 = The Message Handler or the CPU has written new data into the data portion of this Message Object.	0x00	R
31:16	-	Reserved	-	-

43.6.3.5 CAN interrupt pending 1 register

This register contains the INTPND bits of message objects 16 to 1. By reading out the INTPND bits, the CPU can check for which Message Object an interrupt is pending. The INTPND bit of a specific Message Object can be set/reset by the CPU via the IFx Message Interface Registers or by the Message Handler after reception or after a successful transmission of a frame. This will also affect the value of INTPND in the Interrupt Register.

Table 1010. CAN interrupt pending 1 register (IR1, address 0x400E 2140 (C_CAN0) and 0x400A 4140 (C_CAN1)) bit description

Bit	Symbol	Description	Reset value	Access
15:0	INTPND16_1	Interrupt pending bits of message objects 16 to 1. 0 = This message object is ignored by the message handler. 1 = This message object is the source of an interrupt.	0x00	R
31:16	-	Reserved	-	-

43.6.3.6 CAN interrupt pending 2 register

This register contains the INTPND bits of message objects 32 to 17. By reading out the INTPND bits, the CPU can check for which Message Object an interrupt is pending. The INTPND bit of a specific Message Object can be set/reset by the CPU via the IFx Message Interface Registers or by the Message Handler after reception or after a successful transmission of a frame. This will also affect the value of INTPND in the Interrupt Register.

Table 1011. CAN interrupt pending 2 register (IR2, addresses 0x400E 2144 (C_CAN0) and 0x400A 4144 (C_CAN1)) bit description

Bit	Symbol	Description	Reset value	Access
15:0	INTPND32_17	Interrupt pending bits of message objects 32 to 17. 0 = This message object is ignored by the message handler. 1 = This message object is the source of an interrupt.	0x00	R
31:16	-	Reserved	-	-

43.6.3.7 CAN message valid 1 register

This register contains the MSGVAL bits of message objects 16 to 1. By reading out the MSGVAL bits, the CPU can check which Message Object is valid. The MSGVAL bit of a specific Message Object can be set/reset by the CPU via the IFx Message Interface Registers.

Table 1012. CAN message valid 1 register (MSGV1, addresses 0x400E 2160 (C_CAN0) and 0x400A 4160 (C_CAN1)) bit description

Bit	Symbol	Description	Reset value	Access
15:0	MSGVAL16_1	Message valid bits of message objects 16 to 1. 0 = This message object is ignored by the message handler. 1 = This message object is configured and should be considered by the message handler.	0x00	R
31:16	-	Reserved	-	-

43.6.3.8 CAN message valid 2 register

This register contains the MSGVAL bits of message objects 32 to 17. By reading out the MSGVAL bits, the CPU can check which Message Object is valid. The MSGVAL bit of a specific Message Object can be set/reset by the CPU via the IFx Message Interface Registers.

Table 1013. CAN message valid 2 register (MSGV2, address 0x400E 2164 (C_CAN0) and 0x400A 4164 (C_CAN1)) bit description

Bit	Symbol	Description	Access	Reset value
15:0	MSGVAL32_17	Message valid bits of message objects 32 to 17. 0 = This message object is ignored by the message handler. 1 = This message object is configured and should be considered by the message handler.	R	0x00
31:16	-	Reserved	-	-

43.6.4 CAN timing register

43.6.4.1 CAN clock divider register

This register determines the CAN clock signal. The CAN_CLK is derived from the peripheral clock PCLK divided by the values in this register.

Table 1014. CAN clock divider register (CLKDIV, address 0x400E 2180 (C_CAN0) and 0x400A 4180 (C_CAN1)) bit description

Bit	Symbol	Description	Reset value	Access
3:0	CLKDIVVAL	Clock divider value CAN_CLK = PCLK/(CLKDIVVAL +1) 0000: CAN_CLK = PCLK divided by 1. 0001: CAN_CLK = PCLK divided by 2. 0010: CAN_CLK = PCLK divided by 3. 0011: CAN_CLK = PCLK divided by 4. 0100: CAN_CLK = PCLK divided by 5. ... 1111: CAN_CLK = PCLK divided by 16.	0001	R/W
31:4	-	reserved	-	-

43.7 Functional description

43.7.1 C_CAN controller state after reset

After a hardware reset, the registers hold the values described in [Table 971](#). Additionally, the busoff state is reset and the output CAN_TD is set to recessive (HIGH). The value 0x0001 (INIT = '1') in the CAN Control Register enables the software initialization. The CAN controller does not communicate with the CAN bus until the CPU resets INIT to '0'.

The data stored in the message RAM is not affected by a hardware reset. After power-on, the contents of the message RAM is undefined.

43.7.2 C_CAN operating modes

43.7.2.1 Software initialization

The software initialization is started by setting the bit INIT in the CAN Control Register, either by software or by a hardware reset, or by entering the busoff state.

During software initialization (INIT bit is set), the following conditions are present:

- All message transfer from and to the CAN bus is stopped.
- The status of the CAN output CAN_TD is recessive (HIGH).
- The EC counters are unchanged.
- The configuration registers are unchanged.
- Access to the bit timing register and the BRP extension register is enabled if the CCE bit in the CAN control register is also set.

To initialize the CAN controller, software has to set up the bit timing register and each message object. If a message object is not needed, it is sufficient to set its MSGVAL bit to not valid. Otherwise, the whole message object has to be initialized.

Resetting the INIT bit finishes the software initialization. Afterwards the Bit Stream Processor BSP synchronizes itself to the data transfer on the CAN bus by waiting for the occurrence of a sequence of 11 consecutive recessive bits (Bus Idle) before it can take part in bus activities and starts the message transfer.

Remark: The initialization of the Message Objects is independent of INIT and also can be done on the fly, but the Message Objects should all be configured to particular identifiers or set to not valid during software initialization before the BSP starts the message transfer. To change the configuration of a Message Object during normal operation, the CPU has to start by setting the MSGVAL bit to not valid. When the configuration is completed, MSAGVALis set to valid again.

43.7.2.2 CAN message transfer

Once the CAN controller is initialized and INIT is reset to zero, the CAN core synchronizes itself to the CAN bus and starts the message transfer.

Received messages are stored into their appropriate Message Objects if they pass the Message Handler's acceptance filtering. The whole message including all arbitration bits, DLC and eight data bytes is stored into the Message Object. If the Identifier Mask is used, the arbitration bits which are masked to "don't care" may be overwritten in the Message Object.

The CPU may read or write each message any time via the Interface Registers. The Message Handler guarantees data consistency in case of concurrent accesses.

Messages to be transmitted are updated by the CPU. If a permanent Message Object (arbitration and control bits set up during configuration) exists for the message, only the data bytes are updated and then TXRQUT bit with NEWDAT bit are set to start the transmission. If several transmit messages are assigned to the same Message Object (when the number of Message Objects is not sufficient), the whole Message Object has to be configured before the transmission of this message is requested.

The transmission of any number of Message Objects may be requested at the same time, and they are transmitted subsequently according to their internal priority. Messages may be updated or set to not valid any time, even when their requested transmission is still pending. The old data will be discarded when a message is updated before its pending transmission has started.

Depending on the configuration of the Message Object, the transmission of a message may be requested autonomously by the reception of a remote frame with a matching identifier.

43.7.2.3 Disabled Automatic Retransmission (DAR)

According to the *CAN Specification (ISO11898, 6.3.3 Recovery Management)*, the CAN controller provides means for automatic retransmission of frames that have lost arbitration or that have been disturbed by errors during transmission. The frame transmission service will not be confirmed to the user before the transmission is successfully completed. By

default, the automatic retransmission on lost arbitration or error is enabled. It can be disabled to enable the CAN controller to work within a Time Triggered CAN (TTCAN, see ISO11898-1) environment.

The Disable Automatic Retransmission mode is enabled by programming bit DAR in the CAN Control Register to one. In this operation mode the programmer has to consider the different behavior of bits TXRQST and NEWDAT in the Control Registers of the Message Buffers:

- When a transmission starts, bit TXRQST of the respective Message Buffer is reset while bit NEWDAT remains set.
- When the transmission completed successfully, bit NEWDAT is reset.
- When a transmission failed (lost arbitration or error), bit NEWDAT remains set. To restart the transmission, the CPU has to set TXRQST back to one.

43.7.2.4 Test modes

The Test mode is entered by setting bit TEST in the CAN Control Register to one. In Test mode the bits TX1, TX0, LBACK, SILENT, and BASIC in the Test Register are writable. Bit RX monitors the state of pins RD0,1 and therefore is only readable. All Test register functions are disabled when bit TEST is reset to zero.

43.7.2.4.1 Silent mode

The CAN core can be set in Silent mode by programming the Test register bit SILENT to one.

In Silent Mode, the CAN controller is able to receive valid data frames and valid remote frames, but it sends only recessive bits on the CAN bus, and it cannot start a transmission. If the CAN Core is required to send a dominant bit (ACK bit, overload flag, active error flag), the bit is rerouted internally so that the CAN Core monitors this dominant bit, although the CAN bus may remain in recessive state. The Silent mode can be used to analyze the traffic on a CAN bus without affecting it by the transmission of dominant bits (Acknowledge Bits, Error Frames).

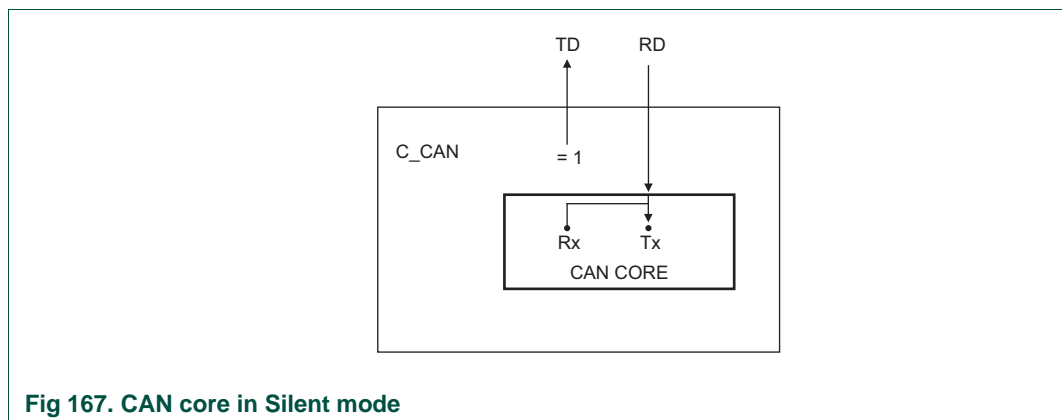

Fig 167. CAN core in Silent mode

43.7.2.4.2 Loop-back mode

The CAN Core can be set in Loop-back mode by programming the Test Register bit LBACK to one. In Loop-back Mode, the CAN Core treats its own transmitted messages as received messages and stores them (if they pass acceptance filtering) into a Receive Buffer.

This mode is provided for self-test functions. To be independent from external stimulation, the CAN Core ignores acknowledge errors (recessive bit sampled in the acknowledge slot of a data/remote frame) in Loop-back mode. In this mode the CAN core performs an internal feedback from its CAN_TD output to its CAN_RD input. The actual value of the CAN_RD input pin is disregarded by the CAN Core. The transmitted messages can be monitored at the CAN_TD pin.

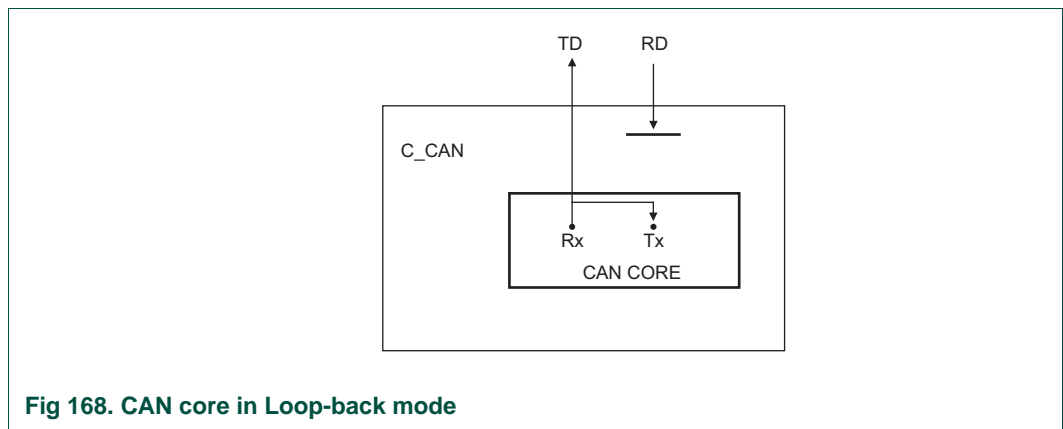

Fig 168. CAN core in Loop-back mode

43.7.2.4.3 Loop-back mode combined with Silent mode

It is also possible to combine Loop-back mode and Silent mode by programming bits LBACK and SILENT to one at the same time. This mode can be used for a “Hot Self test”, meaning the C_CAN can be tested without affecting a running CAN system connected to the pins CAN_TD and CAN_RD. In this mode the CAN_RD pin is disconnected from the CAN Core and the CAN_TD pin is held recessive.

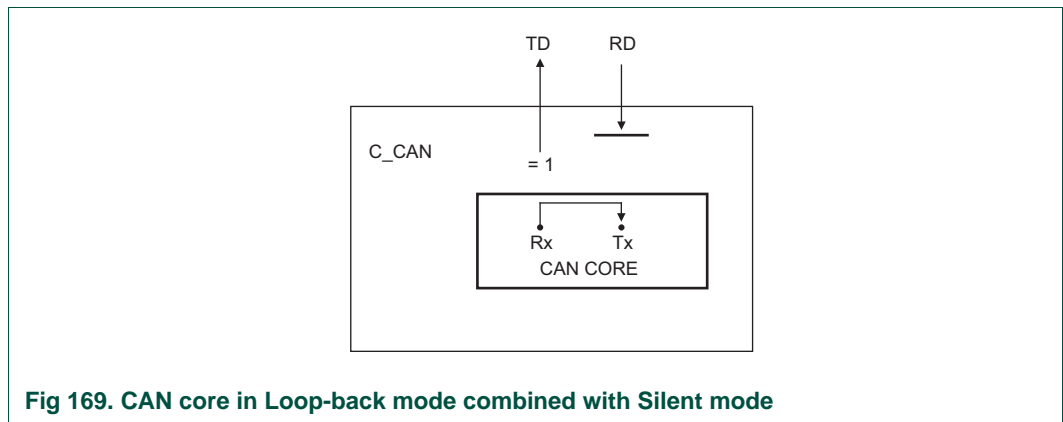

Fig 169. CAN core in Loop-back mode combined with Silent mode

43.7.2.4.4 Basic mode

The CAN Core can be set in Basic mode by programming the Test Register bit BASIC to one. In this mode the CAN controller runs without the Message RAM.

The IF1 Registers are used as Transmit Buffer. The transmission of the contents of the IF1 Registers is requested by writing the BUSY bit of the IF1 Command Request Register to '1'. The IF1 Registers are locked while the BUSY bit is set. The BUSY bit indicates that the transmission is pending.

As soon the CAN bus is idle, the IF1 Registers are loaded into the shift register of the CAN Core and the transmission is started. When the transmission has completed, the BUSY bit is reset and the locked IF1 Registers are released.

A pending transmission can be aborted at any time by resetting the BUSY bit in the IF1 Command Request Register while the IF1 Registers are locked. If the CPU has reset the BUSY bit, a possible retransmission in case of lost arbitration or in case of an error is disabled.

The IF2 Registers are used as Receive Buffer. After the reception of a message the contents of the shift register is stored into the IF2 Registers, without any acceptance filtering.

Additionally, the actual contents of the shift register can be monitored during the message transfer. Each time a read Message Object is initiated by writing the BUSY bit of the IF2 Command Request Register to '1', the contents of the shift register is stored into the IF2 Registers.

In Basic mode the evaluation of all Message Object related control and status bits and of the control bits of the IFx Command Mask Registers is turned off. The message number of the Command request registers is not evaluated. The NEWDAT and MSGLST bits of the IF2 Message Control Register retain their function, DLC3-0 will show the received DLC, the other control bits will be read as '0'.

In Basic mode the ready output CAN_WAIT_B is disabled (always '1')

43.7.2.4.5 Software control of pin CAN_TD

Four output functions are available for the CAN transmit pin CAN_TD:

1. serial data output (default).
2. drives CAN sample point signal to monitor the CAN controller's timing.
3. drives recessive constant value.
4. drives dominant constant value.

The last two functions, combined with the readable CAN receive pin CAN_RD, can be used to check the CAN bus' physical layer.

The output mode of pin CAN_TD is selected by programming the Test Register bits TX1 and TX0 as described [Section 43.6.1.6](#).

Remark: The three test functions for pin CAN_TD interfere with all CAN protocol functions. The CAN_TD pin must be left in its default function when CAN message transfer or any of the test modes Loo-back mode, Silent mode, or Basic mode are selected.

43.7.3 CAN message handler

The Message handler controls the data transfer between the Rx/Tx Shift Register of the CAN Core, the Message RAM and the IFx Registers, see [Figure 166](#).

The message handler controls the following functions:

- Data Transfer between IFx Registers and the Message RAM
- Data Transfer from Shift Register to the Message RAM
- Data Transfer from Message RAM to Shift Register
- Data Transfer from Shift Register to the Acceptance Filtering unit
- Scanning of Message RAM for a matching Message Object
- Handling of TXRQST flags
- Handling of interrupts

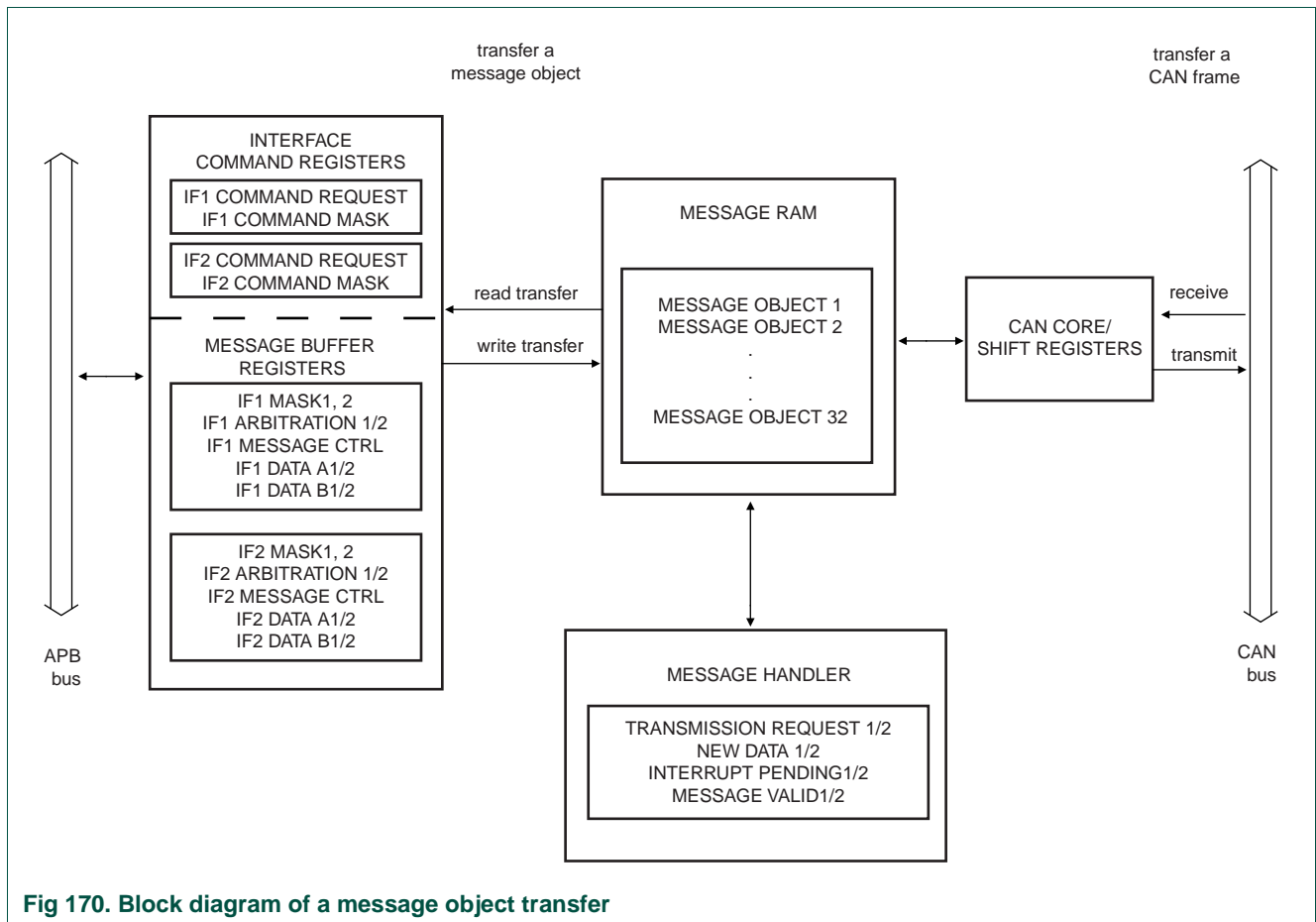

Fig 170. Block diagram of a message object transfer

43.7.3.1 Management of message objects

The configuration of the Message Objects in the Message RAM will (with the exception of the bits MSGVAL, NEWDAT, INTPND, and TXRQST) is not be affected by resetting the chip. All the Message Objects must be initialized by the CPU or they must be set to not valid (MSGVAL = '0'). The bit timing must be configured before the CPU clears the INIT bit in the CAN Control Register.

The configuration of a Message Object is done by programming Mask, Arbitration, Control and Data field of one of the two interface register sets to the desired values. By writing to the corresponding IFx Command Request Register, the IFx Message Buffer Registers are loaded into the addressed Message Object in the Message RAM.

When the INIT bit in the CAN Control Register is cleared, the CAN Protocol Controller state machine of the CAN core and the Message Handler State Machine control the CAN controller's internal data flow. Received messages that pass the acceptance filtering are stored into the Message RAM, and messages with pending transmission request are loaded into the CAN core's shift register and are transmitted via the CAN bus.

The CPU reads received messages and updates messages to be transmitted via the IFx Interface Registers. Depending on the configuration, the CPU is interrupted on certain CAN message and CAN error events.

43.7.3.2 Data Transfer between IFx Registers and the Message RAM

When the CPU initiates a data transfer between the IFx Registers and Message RAM, the Message Handler sets the BUSY bit in the respective Command Register to '1'. After the transfer has completed, the BUSY bit is set back to '0'.

The Command Mask Register specifies whether a complete Message Object or only parts of it will be transferred. Due to the structure of the Message RAM it is not possible to write single bits/bytes of one Message Object. Software must always write a complete Message Object into the Message RAM. Therefore the data transfer from the IFx Registers to the Message RAM requires a read-modify-write cycle:

1. Read the parts of the message object that are not to be changed from the message RAM using the command mask register.
 - After the partial read of a Message Object, the Message Buffer Registers that are not selected in the Command Mask Register will be left unchanged.
2. Write the complete contents of the message buffer registers into the message object.
 - After the partial write of a Message Object, the Message Buffer Registers that are not selected in the Command Mask Register will set to the actual contents of the selected Message Object.

43.7.3.3 Transmission of messages between the shift registers in the CAN core and the Message buffer

If the shift register of the CAN Core cell is ready for loading and if there is no data transfer between the IFx Registers and Message RAM, the MSGVAL bits in the Message Valid Register TXRQST bits in the Transmission Request Register are evaluated. The valid Message Object with the highest priority pending transmission request is loaded into the shift register by the Message Handler and the transmission is started. The Message Object's NEWDAT bit is reset.

After a successful transmission and if no new data was written to the Message Object (NEWDAT = '0') since the start of the transmission, the TXRQST bit will be reset. If TXIE is set, INTPND will be set after a successful transmission. If the CAN controller has lost the arbitration or if an error occurred during the transmission, the message will be retransmitted as soon as the CAN bus is free again. If meanwhile the transmission of a message with higher priority has been requested, the messages will be transmitted in the order of their priority.

43.7.3.4 Acceptance filtering of received messages

When the arbitration and control field (Identifier + IDE + RTR + DLC) of an incoming message is completely shifted into the Rx/Tx Shift Register of the CAN Core, the Message Handler state machine starts the scanning of the Message RAM for a matching valid Message Object.

To scan the Message RAM for a matching Message Object, the Acceptance Filtering unit is loaded with the arbitration bits from the CAN Core shift register. Then the arbitration and mask fields (including MSGVAL, UMASK, NEWDAT, and EOB) of Message Object 1 are loaded into the Acceptance Filtering unit and compared with the arbitration field from the shift register. This is repeated with each following Message Object until a matching Message Object is found or until the end of the Message RAM is reached.

If a match occurs, the scanning is stopped and the Message Handler state machine proceeds depending on the type of frame (Data Frame or Remote Frame) received.

43.7.3.4.1 Reception of a data frame

The Message Handler state machine stores the message from the CAN Core shift register into the respective Message Object in the Message RAM. The data bytes, all arbitration bits, and the Data Length Code are stored into the corresponding Message Object. This is implemented to keep the data bytes connected with the identifier even if arbitration mask registers are used.

The NEWDAT bit is set to indicate that new data (not yet seen by the CPU) has been received. The CPU/software should reset NEWDAT when it reads the Message Object. If at the time of the reception the NEWDAT bit was already set, MSGLST is set to indicate that the previous data (supposedly not seen by the CPU) is lost. If the RxIE bit is set, the INTPND bit is also set, causing the Interrupt Register to point to this Message Object.

The TXRQST bit of this Message Object is reset to prevent the transmission of a Remote Frame, while the requested Data Frame has just been received.

43.7.3.4.2 Reception of a remote frame

When a Remote Frame is received, three different configurations of the matching Message Object have to be considered:

1. DIR = '1' (direction = transmit), RMTEN = '1', UMASK = '1' or '0'

On the reception of a matching Remote Frame, the TXRQST bit of this Message Object is set. The rest of the Message Object remains unchanged.

2. DIR = '1' (direction = transmit), RMTEN = '0', UMASK = '0'

On the reception of a matching Remote Frame, the TXRQST bit of this Message Object remains unchanged; the Remote Frame is ignored.

3. DIR = '1' (direction = transmit), RMTEN = '0', UMASK = '1'

On the reception of a matching Remote Frame, the TXRQST bit of this Message Object is reset. The arbitration and control field (Identifier + IDE + RTR + DLC) from the shift register is stored into the Message Object in the Message RAM, and the NEWDAT bit of this Message Object is set. The data field of the Message Object remains unchanged; the Remote Frame is treated similar to a received Data Frame.

43.7.3.5 Receive/transmit priority

The receive/transmit priority for the Message Objects is attached to the message number. Message Object 1 has the highest priority, while Message Object 32 has the lowest priority. If more than one transmission request is pending, they are serviced due to the priority of the corresponding Message Object.

43.7.3.6 Configuration of a transmit object

[Table 1015](#) shows how a transmit object should be initialized by software (see also [Table 981](#)):

Table 1015. Initialization of a transmit object

MSGVAL	Arbitration bits	Data bits	Mask bits	EOB	DIR	NEWDAT
1	application dependent	application dependent	application dependent	1	1	0
MSGLST	RXIE	TXIE	INTPND	RMTEN	TXRQST	
0	0	application dependent	0	application dependent	0	

The Arbitration Registers (ID28:0 and XTD bit) are given by the application. They define the identifier and the type of the outgoing message. If an 11-bit Identifier (“Standard Frame”) is used, it is programmed to ID28. In this case ID18, ID17 to ID0 can be disregarded.

If the TXIE bit is set, the INTPND bit will be set after a successful transmission of the Message Object.

If the RMTEN bit is set, a matching received Remote Frame will cause the TXRQST bit to be set, and the Remote Frame will autonomously be answered by a Data Frame.

The Data Registers (DLC3:0, Data0:7) are given by the application. TXRQST and RMTEN may not be set before the data is valid.

The Mask Registers (Msk28-0, UMASK, MXTD, and MDIR bits) may be used (UMASK=’1’) to allow groups of Remote Frames with similar identifiers to set the TXRQST bit. For details see [Section 43.7.3.4.2](#). The DIR bit should not be masked.

43.7.3.7 Updating a transmit object

The CPU may update the data bytes of a Transmit Object any time via the IFx Interface registers. Neither MSGVAL nor TXRQST have to be reset before the update.

Even if only a part of the data bytes are to be updated, all four bytes of the corresponding IFx Data A Register or IFx Data B Register have to be valid before the content of that register is transferred to the Message Object. Either the CPU has to write all four bytes into the IFx Data Register or the Message Object is transferred to the IFx Data Register before the CPU writes the new data bytes.

When only the (eight) data bytes are updated, first 0x0087 is written to the Command Mask Register. Then the number of the Message Object is written to the Command Request Register, concurrently updating the data bytes and setting TXRQST.

To prevent the reset of TXRQST at the end of a transmission that may already be in progress while the data is updated, NEWDAT has to be set together with TXRQST. For details see [Section 43.7.3.3](#).

When NEWDAT is set together with TXRQST, NEWDAT will be reset as soon as the new transmission has started.

43.7.3.8 Configuration of a receive object

[Table 1016](#) shows how a receive object should be initialized by software (see also [Table 981](#))

Table 1016. Initialization of a receive object

MSGVAL	Arbitration bits	Data bits	Mask bits	EOB	DIR	NEWDAT
1	application dependent	application dependent	application dependent	1	0	0
MSGLST	RXIE	TXIE	INTPND	RMTEN	TXRQST	
0	application dependent	0	0	0	0	

The Arbitration Registers (ID28-0 and XTD bit) are given by the application. They define the identifier and type of accepted received messages. If an 11-bit Identifier (“Standard Frame”) is used, it is programmed to ID28 to ID18. ID17 to ID0 can then be disregarded. When a Data Frame with an 11-bit Identifier is received, ID17 to ID0 will be set to ‘0’.

If the RxIE bit is set, the INTPND bit will be set when a received Data Frame is accepted and stored in the Message Object.

The Data Length Code (DLC[3:0]) is given by the application. When the Message Handler stores a Data Frame in the Message Object, it will store the received Data Length Code and eight data bytes. If the Data Length Code is less than 8, the remaining bytes of the Message Object will be overwritten by non specified values.

The Mask Registers (Msk[28:0], UMASK, MXTD, and MDIR bits) may be used (UMASK=‘1’) to allow groups of Data Frames with similar identifiers to be accepted. For details see section [Section 43.7.3.4.1](#). The DIR bit should not be masked in typical applications.

43.7.3.9 Handling of received messages

The CPU may read a received message any time via the IFx Interface registers. The data consistency is guaranteed by the Message Handler state machine.

To transfer the entire received message from message RAM into the message buffer, software must write first 0x007F to the Command Mask Register and then the number of the Message Object to the Command Request Register. Additionally, the bits NEWDAT and INTPND are cleared in the Message RAM (not in the Message Buffer).

If the Message Object uses masks for acceptance filtering, the arbitration bits show which of the matching messages has been received.

The actual value of NEWDAT shows whether a new message has been received since last time this Message Object was read. The actual value of MSGGLST shows whether more than one message has been received since last time this Message Object was read. MSGGLST will not be automatically reset.

Using a Remote Frame, the CPU may request another CAN node to provide new data for a receive object. Setting the TXRQST bit of a receive object will cause the transmission of a Remote Frame with the receive object's identifier. This Remote Frame triggers the other CAN node to start the transmission of the matching Data Frame. If the matching Data Frame is received before the Remote Frame could be transmitted, the TXRQST bit is automatically reset.

43.7.3.10 Configuration of a FIFO buffer

With the exception of the EOB bit, the configuration of Receive Objects belonging to a FIFO Buffer is the same as the configuration of a (single) Receive Object, see section [Section 43.7.3.8](#).

To concatenate two or more Message Objects into a FIFO Buffer, the identifiers and masks (if used) of these Message Objects have to be programmed to matching values. Due to the implicit priority of the Message Objects, the Message Object with the lowest number will be the first Message Object of the FIFO Buffer. The EOB bit of all Message Objects of a FIFO Buffer except the last have to be programmed to zero. The EOB bits of the last Message Object of a FIFO Buffer is set to one, configuring it as the End of the Block.

43.7.3.10.1 Reception of messages with FIFO buffers

Received messages with identifiers matching to a FIFO Buffer are stored into a Message Object of this FIFO Buffer starting with the Message Object with the lowest message number.

When a message is stored into a Message Object of a FIFO Buffer the NEWDAT bit of this Message Object is set. By setting NEWDAT while EOB is zero the Message Object is locked for further write accesses by the Message Handler until the CPU has written the NEWDAT bit back to zero.

Messages are stored into a FIFO Buffer until the last Message Object of this FIFO Buffer is reached. If none of the preceding Message Objects is released by writing NEWDAT to zero, all further messages for this FIFO Buffer will be written into the last Message Object of the FIFO Buffer and therefore overwrite previous messages.

43.7.3.10.2 Reading from a FIFO buffer

When the CPU transfers the contents of Message Object to the IFx Message Buffer registers by writing its number to the IFx Command Request Register, bits NEWDAT and INTPND in the corresponding Command Mask Register should be reset to zero (TXRQST/NEWDAT = '1' and ClrINTPND = '1'). The values of these bits in the Message Control Register always reflect the status before resetting the bits.

To assure the correct function of a FIFO Buffer, the CPU should read out the Message Objects starting at the FIFO Object with the lowest message number.

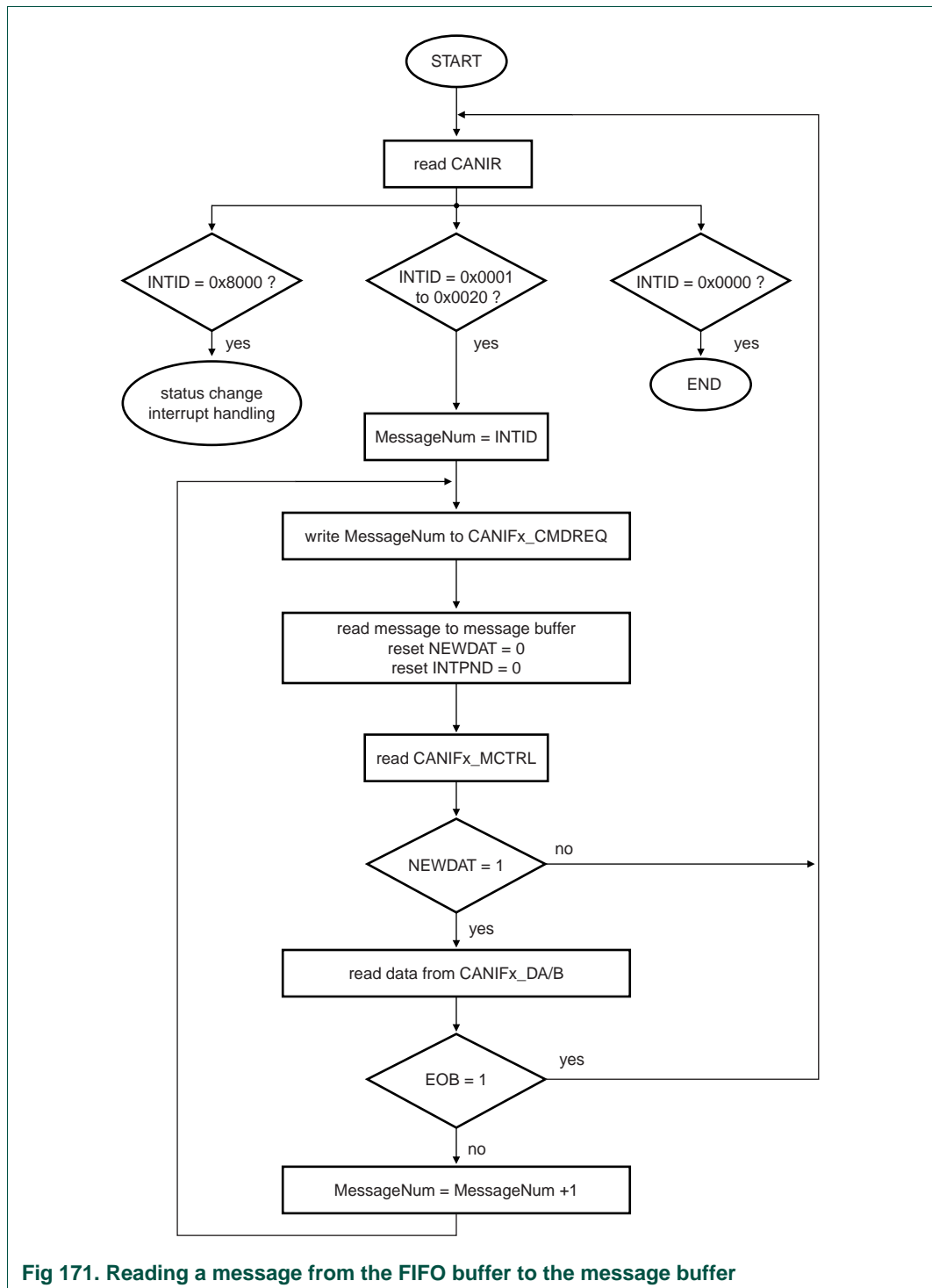

43.7.4 Interrupt handling

If several interrupts are pending, the CAN Interrupt Register will point to the pending interrupt with the highest priority, disregarding their chronological order. An interrupt remains pending until the CPU has cleared it.

The Status Interrupt has the highest priority. Among the message interrupts, the Message Object's interrupt priority decreases with increasing message number.

A message interrupt is cleared by clearing the Message Object's INTPND bit. The Status Interrupt is cleared by reading the Status Register.

The interrupt identifier INTID in the Interrupt Register indicates the cause of the interrupt. When no interrupt is pending, the register will hold the value zero. If the value of the Interrupt Register is different from zero, then there is an interrupt pending and, if IE is set, the interrupt line to the CPU, IRQ_B, is active. The interrupt line remains active until the Interrupt Register is back to value zero (the cause of the interrupt is reset) or until IE is reset.

The value 0x8000 indicates that an interrupt is pending because the CAN Core has updated (not necessarily changed) the Status Register (Error Interrupt or Status Interrupt). This interrupt has the highest priority. The CPU can update (reset) the status bits RXOK, TXOK and LEC, but a write access of the CPU to the Status Register can never generate or reset an interrupt.

All other values indicate that the source of the interrupt is one of the Message Objects where INTID points to the pending message interrupt with the highest interrupt priority.

The CPU controls whether a change of the Status Register may cause an interrupt (bits EIE and SIE in the CAN Control Register) and whether the interrupt line becomes active when the Interrupt Register is different from zero (bit IE in the CAN Control Register). The Interrupt Register will be updated even when IE is reset.

The CPU has two possibilities to follow the source of a message interrupt:

- Software can follow the INTID in the Interrupt Register.
- Software can poll the interrupt pending register.

An interrupt service routine reading the message that is the source of the interrupt may read the message and reset the Message Object's INTPND at the same time (bit ClrINTPND in the Command Mask Register). When INTPND is cleared, the Interrupt Register will point to the next Message Object with a pending interrupt.

43.7.5 Bit timing

Even if minor errors in the configuration of the CAN bit timing do not result in immediate failure, the performance of a CAN network can be reduced significantly. In many cases, the CAN bit synchronization will amend a faulty configuration of the CAN bit timing to such a degree that only occasionally an error frame is generated. In the case of arbitration however, when two or more CAN nodes simultaneously try to transmit a frame, a misplaced sample point may cause one of the transmitters to become error passive.

The analysis of such sporadic errors requires a detailed knowledge of the CAN bit synchronization inside a CAN node and of the CAN nodes' interaction on the CAN bus.

43.7.5.1 Bit time and bit rate

CAN supports bit rates in the range of lower than 1 kBit/s up to 1000 kBit/s. Each member of the CAN network has its own clock generator, usually a quartz oscillator. The timing parameter of the bit time (i.e. the reciprocal of the bit rate) can be configured individually for each CAN node, creating a common bit rate even though the CAN nodes' oscillator periods (f_{osc}) may be different.

The frequencies of these oscillators are not absolutely stable, as small variations are caused by changes in temperature or voltage and by deteriorating components. As long as the variations remain inside a specific oscillator tolerance range (df), the CAN nodes are able to compensate for the different bit rates by re-synchronizing to the bit stream.

According to the CAN specification, the bit time is divided into four segments ([Figure 172](#)). The Synchronization Segment, the Propagation Time Segment, the Phase Buffer Segment 1, and the Phase Buffer Segment 2. Each segment consists of a specific, programmable number of time quanta (see [Table 1017](#)). The length of the time quantum (t_q), which is the basic time unit of the bit time, is defined by the CAN controller's system clock f and the Baud Rate Prescaler (BRP): $t_q = BRP / f_{sys}$. The C_CAN's system clock f_{sys} is the frequency C_CAN peripheral clock.

The Synchronization Segment Sync_Seg is the part of the bit time where edges of the CAN bus level are expected to occur; the distance between an edge that occurs outside of Sync_Seg and the Sync_Seg is called the phase error of that edge. The Propagation Time Segment Prop_Seg is intended to compensate for the physical delay times within the CAN network. The Phase Buffer Segments Phase_Seg1 and Phase_Seg2 surround the Sample Point. The (Re-)Synchronization Jump Width (SJW) defines how far a re-synchronization may move the Sample Point inside the limits defined by the Phase Buffer Segments to compensate for edge phase errors.

[Table 1017](#) describes the minimum programmable ranges required by the CAN protocol. Bit time parameters are programmed through the BT register, [Table 976](#). For details on bit timing and examples, see the *C_CAN user's manual, revision 1.2*.

Table 1017. Parameters of the C_CAN bit time

Parameter	Range	Function
BRP	(1...32)	Defines the length of the time quantum t_q .
SYNC_SEG	$1t_q$	Synchronization segment. Fixed length. Synchronization of bus input to system clock.
PROP_SEG	$(1...8) \times t_q$	Propagation time segment. Compensates for physical delay times. This parameter is determined by the system delay times in the C_CAN network.
PHASE_SEG1	$(1...8) \times t_q$	Phase buffer segment 1. May be lengthened temporarily by synchronization.
PHASE_SEG2 (TSEG2)	$(1...8) \times t_q$	Phase buffer segment 2. May be shortened temporarily by synchronization.
SJW	$(1...4) \times t_q$	(Re-) synchronization jump width. May not be longer than either phase buffer segment.

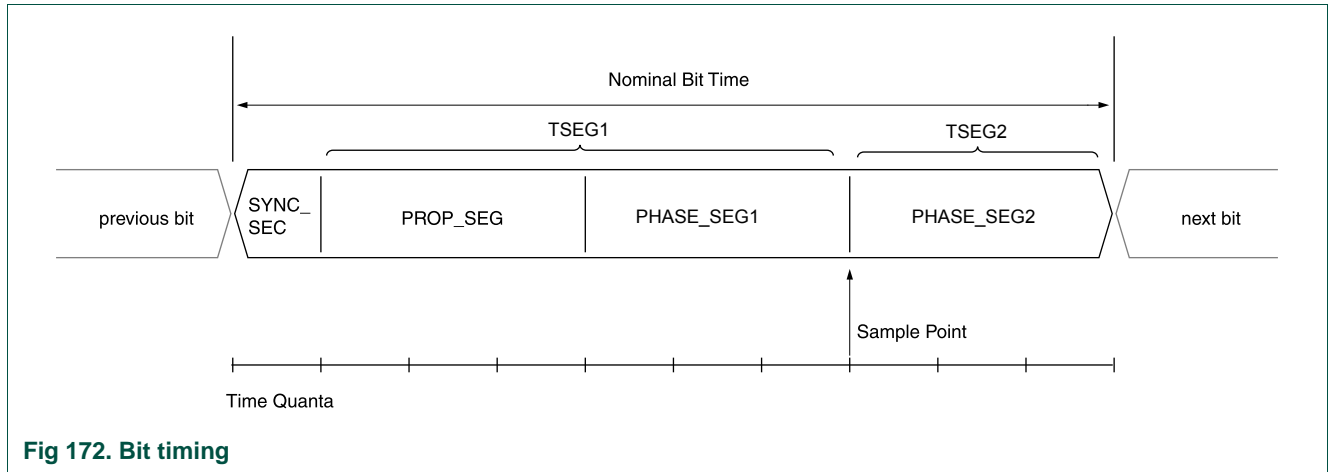

Fig 172. Bit timing

43.7.5.1.1 Calculating the C_CAN bit rate

The C_CAN clock is derived from the BASE_APB3_CLK (for CAN0) or from BASE_APB1_CLK (CAN1). The C_CAN clock can be divided by the C_CAN clock divider (Table 1014): $CAN_CLK = BASE_APB3_CLK / (DIVVAL + 1)$ or $CAN_CLK = BASE_APB1_CLK / (DIVVAL + 1)$.

Using Figure 172 and Table 1017, the bit rate and sample point can be expressed as follows using $t_q = BRP / CAN_CLK$:

$$\text{Bit rate} = 1 / (t_q \times \text{total number of quantas}) = 1 / (t_q \times (1 + PROP_SEG + TSEG1 + TSEG2)) = CAN_CLK / (BRP \times (1 + PROP_SEG + TSEG1 + TSEG2))$$

$$\text{Sample point} = (1 + PROP_SEG + TSEG1) / (1 + PROP_SEG + TSEG1 + TSEG2) \times 100$$

The CAN BT register (see Table 976) stores the bit timing information for parameters BRP (bits 5:0), PROP_SEG + TSEG1 (bits 11:8, named TSEG1), and TSEG2. Note that the register content are +1 encoded.

Using the contents of the BT register for BRP, TSEG1, and TSEG2, the bit rate can be calculated as follows:

$$\text{Bit rate} = CAN_CLK / ((BRP + 1) \times (TSEG1 + 2 + TSEG2 + 1))$$

$$\text{Sample point} = (TSEG1 + 2) / (TSEG1 + 2 + TSEG2 + 1) \times 100$$

44.1 How to read this chapter

ADC0 and ADC1 are available on all LPC18xx parts. The number of ADC channels is limited on small packages.

Remark: All ADC input channels are shared between ADC0 and ADC1.

Table 1018.ADC channels for different packages

Analog function	Pin	LBGA256	TFBGA180	TFBGA100	LQFP208	LQFP144
ADC0_0; Shared between 10-bit ADC0/1 and DAC.	P4_3	yes	yes	-	yes	yes
ADC0_1; Shared between 10-bit ADC0/1.	P4_1	yes	yes	-	yes	yes
ADC0_2; Shared between 10-bit ADC0/1.	PF_8	yes	-	-	-	-
ADC0_3; Shared between 10-bit ADC0/1.	P7_5	yes	yes	-	yes	yes
ADC0_4; Shared between 10-bit ADC0/1.	P7_4	yes	yes	-	yes	yes
ADC0_5; Shared between 10-bit ADC0/1.	PF_10	yes	-	-	yes	-
ADC0_6; Shared between 10-bit ADC0/1.	PB_6	yes	yes	-	-	-
DAC; Shared between 10-bit ADC0/1 and DAC.	P4_4	yes	yes	-	yes	yes
ADC1_0; Shared between 10-bit ADC0/1 and DAC.	PC_3	yes	-	-	yes	-
ADC1_1; Shared between 10-bit ADC0/1.	PC_0	yes	yes	-	yes	-
ADC1_2; Shared between 10-bit ADC0/1.	PF_9	yes	-	-	yes	-
ADC1_3; Shared between 10-bit ADC0/1.	PF_6	yes	-	-	yes	-
ADC1_4; Shared between 10-bit ADC0/1.	PF_5	yes	-	-	yes	-
ADC1_5; Shared between 10-bit ADC0/1.	PF_11	yes	-	-	yes	-
ADC1_6; Shared between 10-bit ADC0/1.	P7_7	yes	yes	-	yes	yes
ADC1_7; Shared between 10-bit ADC0/1.	PF_7	yes	-	-	yes	-
ADC input channel 0. Shared between 10-bit ADC0/1 and DAC.	ADC0_0/ ADC1_0/DAC	yes	yes	yes	yes	yes
ADC input channel 1. Shared between 10-bit ADC0/1.	ADC0_1/ ADC1_1	yes	yes	yes	yes	yes
ADC input channel 2. Shared between 10-bit ADC0/1.	ADC0_2/ ADC1_2	yes	yes	yes	yes	yes
ADC input channel 3. Shared between 10-bit ADC0/1.	ADC0_3/ ADC1_3	yes	yes	yes	yes	yes
ADC input channel 4. Shared between 10-bit ADC0/1.	ADC0_4/ ADC1_4	yes	yes	-	yes	yes
ADC input channel 5. Shared between 10-bit ADC0/1.	ADC0_5/ ADC1_5	yes	yes	-	yes	yes
ADC input channel 6. Shared between 10-bit ADC0/1.	ADC0_6/ ADC1_6	yes	yes	-	yes	yes
ADC input channel 7. Shared between 10-bit ADC0/1.	ADC0_7/ ADC1_7	yes	yes	-	yes	yes

44.2 Basic configuration

The ADC0 and ADC1 are configured as follows:

- See [Table 1019](#) for clocking and power control.
- The ADC0 is reset by the ADC0_RST (reset # 40).
- The ADC1 is reset by the ADC1_RST (reset # 41).
- The ADC0 interrupt is connected to interrupt slot # 17 in the NVIC.
- The ADC1 interrupt is connected to interrupt slot # 21 in the NVIC.
- For connecting to the GPDMA, use the DMAMUX register ([Table 92](#)) in the CREG block and enable the GPDMA channel in the DMA Channel Configuration registers [Section 19.6.20](#).
- External pins (ADCTRIG0/1) and the MOTOCON PWM MCOA2 output can be selected as conversion triggers for ADC0/1 (see [Table 1023](#)).
- The ADC conversion triggers are connected through the GIMA (see [Table 190](#)) to the timers or SCT outputs.
- For the ADC0 and ADC1 inputs that are multiplexed with digital functions, the pins need to be configured using the ENAIO0/1 registers (see [Section 16.4.6](#) and [Section 16.4.8](#)).
- The ADC1 channel 7 can be connected to the bandgap reference (see [Section 16.4.8.1](#)).

Table 1019. ADC0/1 clocking and power control

	Base clock	Branch clock	Operating frequency	Notes
ADC0 clock	BASE_APB3_CLK	CLK_APB3_ADC0	up to 180 MHz	For register interface and ADC0 conversion rate.
ADC1 clock	BASE_APB3_CLK	CLK_APB3_ADC1	up to 180 MHz	For register interface and ADC1 conversion rate.

44.3 Features

- 10-bit successive approximation analog to digital converter.
- Input multiplexing among 8 pins.
- Power-down mode.
- Measurement range 0 to 3.3 V.
- 10-bit conversion time = 2.45 μ s.
- Burst conversion mode for single or multiple inputs.
- Optional conversion on transition on input pin or Timer Match signal.
- Individual result registers for each A/D channel to reduce interrupt overhead.
- Connected to bandgap reference (see [Section 16.4.8.1](#)).

44.4 General description

Basic clocking for the A/D converters is provided by the APB clocks (CLK_APB3_ADC0/1). A programmable divider is included in each converter to scale this clock to the 4.5 MHz (max) clock needed by the successive approximation process. A fully accurate conversion requires 11 of these clocks.

44.5 Pin description

[Table 1020](#) gives a brief summary of each of ADC related pins.

Remark: These parts contain two 10-bit ADCs (ADC0 and ADC1). The input channels of ADC0 and ADC1 on dedicated pins and multiplexed pins are combined in such a way that all channel 0 inputs (named ADC0_0 and ADC1_0) are tied together and connected to both, channel 0 on ADC0 and channel 0 on ADC1, channel 1 inputs (named ADC0_1 and ADC1_1) are tied together and connected to channel 1 on ADC0 and ADC1, and so forth. There are eight ADC channels total for the two ADCs.

Table 1020.ADC pin description

Pin function	Type	Description
ADC0_[7:0]/A ADC1_[7:0]	Input	Shared Analog Inputs. The A/D converter cell can measure the voltage on any of these input signals. The inputs are shared between ADC0 and ADC1 on analog-only pins Remark: The ADC0 pin is shared with the DAC0 pin.
ADC0_[6:0]	Input	Analog inputs. Inputs from multiplexed analog/digital pins to ADC0. The A/D converter cell can measure the voltage on any of these input signals. These pins are shared with ADC1.
ADC1_[7:0]	Input	Analog inputs. Inputs from multiplexed analog/digital pins to ADC1. The A/D converter cell can measure the voltage on any of these input signals. These pins are shared with ADC0.
ADCTRIG0	Input	Trigger inputs to the ADC0/1.

Table 1020.ADC pin description

Pin function	Type	Description
ADCTRIG1	Input	Trigger inputs to the ADC0/1.
VDDA	Power	Analog Power. Also voltage reference VREF for both ADCs.
VSSA	Ground	Analog ground.

44.6 Register description

The register addresses for the ADC0 are shown in [Table 1021](#)

Table 1021.Register overview: ADC0 (base address 0x400E 3000)

Name	Access	Address offset	Description	Reset value ^[1]	Reference
CR	R/W	0x000	A/D Control Register. The AD0CR register must be written to select the operating mode before A/D conversion can occur.	0x0000 0000	Table 1023
GDR	RO	0x004	A/D Global Data Register. Contains the result of the most recent A/D conversion.	-	Table 1024
-	-	0x008	Reserved.	-	
INTEN	R/W	0x00C	A/D Interrupt Enable Register. This register contains enable bits that allow the DONE flag of each A/D channel to be included or excluded from contributing to the generation of an A/D interrupt.	0x0000 0100	Table 1025
DR0	RO	0x010	A/D Channel 0 Data Register. This register contains the result of the most recent conversion completed on channel 0	-	Table 1026
DR1	RO	0x014	A/D Channel 1 Data Register. This register contains the result of the most recent conversion completed on channel 1.	-	Table 1026
DR2	RO	0x018	A/D Channel 2 Data Register. This register contains the result of the most recent conversion completed on channel 2.	-	Table 1026
DR3	RO	0x01C	A/D Channel 3 Data Register. This register contains the result of the most recent conversion completed on channel 3.	-	Table 1026
DR4	RO	0x020	A/D Channel 4 Data Register. This register contains the result of the most recent conversion completed on channel 4.	-	Table 1026
DR5	RO	0x024	A/D Channel 5 Data Register. This register contains the result of the most recent conversion completed on channel 5.	-	Table 1026
DR6	RO	0x028	A/D Channel 6 Data Register. This register contains the result of the most recent conversion completed on channel 6.	-	Table 1026
DR7	RO	0x02C	A/D Channel 7 Data Register. This register contains the result of the most recent conversion completed on channel 7.	-	Table 1026
STAT	RO	0x030	A/D Status Register. This register contains DONE and OVERRUN flags for all of the A/D channels, as well as the A/D interrupt flag.	0	Table 1027

[1] Reset value reflects the data stored in used bits only. It does not include reserved bits content.

Table 1022. Register overview: ADC1 (base address 0x400E 4000)

Name	Access	Address offset	Description	Reset value ^[1]	Reference
CR	R/W	0x000	A/D Control Register. The AD1CR register must be written to select the operating mode before A/D conversion can occur.	0x0000 0000	Table 1023
GDR	R0	0x004	A/D Global Data Register. Contains the result of the most recent A/D conversion.	-	Table 1024
-	-	0x008	Reserved.	-	
INTEN	R/W	0x00C	A/D Interrupt Enable Register. This register contains enable bits that allow the DONE flag of each A/D channel to be included or excluded from contributing to the generation of an A/D interrupt.	0x0000 0100	Table 1025
DR0	RO	0x010	A/D Channel 0 Data Register. This register contains the result of the most recent conversion completed on channel 0	-	Table 1026
DR1	RO	0x014	A/D Channel 1 Data Register. This register contains the result of the most recent conversion completed on channel 1.	-	Table 1026
DR2	RO	0x018	A/D Channel 2 Data Register. This register contains the result of the most recent conversion completed on channel 2.	-	Table 1026
DR3	RO	0x01C	A/D Channel 3 Data Register. This register contains the result of the most recent conversion completed on channel 3.	-	Table 1026
DR4	RO	0x020	A/D Channel 4 Data Register. This register contains the result of the most recent conversion completed on channel 4.	-	Table 1026
DR5	RO	0x024	A/D Channel 5 Data Register. This register contains the result of the most recent conversion completed on channel 5.	-	Table 1026
DR6	RO	0x028	A/D Channel 6 Data Register. This register contains the result of the most recent conversion completed on channel 6.	-	Table 1026
DR7	RO	0x02C	A/D Channel 7 Data Register. This register contains the result of the most recent conversion completed on channel 7.	-	Table 1026
STAT	RO	0x030	A/D Status Register. This register contains DONE and OVERRUN flags for all of the A/D channels, as well as the A/D interrupt flag.	0	Table 1027

[1] Reset value reflects the data stored in used bits only. It does not include reserved bits content.

44.6.1 A/D Control register

The A/D Control Register provides bits to select A/D channels to be converted, A/D timing, A/D modes, and the A/D start trigger.

Table 1023.A/D Control register (CR - address 0x400E 3000 (ADC0) and 0x400E 4000 (ADC1)) bit description

Bit	Symbol	Value	Description	Reset value
7:0	SEL		Selects which of the ADCn_[7:0] inputs are to be sampled and converted. Bit 0 selects ADCn_0, bit 1 selects pin ADCn_1,..., and bit 7 selects pin ADCn_7. In software-controlled mode, only one of these bits should be 1. In hardware scan mode, any value containing 1 to 8 ones is allowed. All zeroes is equivalent to SEL = 0x01.	0
15:8	CLKDIV		The ADC clock is divided by the CLKDIV value plus one to produce the clock for the A/D converter, which should be less than or equal to 4.5 MHz. Typically, software should program the smallest value in this field that yields a clock of 4.5 MHz or slightly less, but in certain cases (such as a high-impedance analog source) a slower clock may be desirable.	0
16	BURST	0	Controls Burst mode Conversions are software controlled and require 11 clocks.	0
		1	The AD converter does repeated conversions at the rate selected by the CLKS field, scanning (if necessary) through the pins selected by 1s in the SEL field. The first conversion after the start corresponds to the least-significant 1 in the SEL field, then higher numbered 1 bits (pins) if applicable. Repeated conversions can be terminated by clearing this bit, but the conversion that's in progress when this bit is cleared will be completed. The conversion result is stored in the DR0 to DR7 registers, The GDR does not contain valid conversion results in burst mode. Important: START bits must be 000 when BURST = 1 or conversions will not start.	
19:17	CLKS		This field selects the number of clocks used for each conversion in Burst mode and the number of bits of accuracy of the result in the LS bits of ADDR, between 11 clocks (10 bits) and 4 clocks (3 bits).	000
		0x0	11 clocks / 10 bits	
		0x1	10 clocks / 9 bits	
		0x2	9 clocks / 8 bits	
		0x3	8 clocks / 7 bits	
		0x4	7 clocks / 6 bits	
		0x5	6 clocks / 5 bits	
		0x6	5 clocks / 4 bits	
0x7	4 clocks / 3 bits			
20	-	-	Reserved, user software should not write ones to reserved bits. The value read from a reserved bit is not defined.	-
21	PDN	0	Power mode The A/D converter is in Power-down mode.	0
		1	The A/D converter is operational.	
23:22	-	-	Reserved, user software should not write ones to reserved bits. The value read from a reserved bit is not defined.	-

Table 1023.A/D Control register (CR - address 0x400E 3000 (ADC0) and 0x400E 4000 (ADC1)) bit description

Bit	Symbol	Value	Description	Reset value
26:24	START		Controls the start of an A/D conversion when the BURST bit is 0.	0
		0x0	No start (this value should be used when clearing PDN to 0).	
		0x1	Start now.	
		0x2	Start conversion when the edge selected by bit 27 occurs on CTOUT_15 (combined timer output 15, ADC start0).	
		0x3	Start conversion when the edge selected by bit 27 occurs on CTOUT_8 (combined timer output 8, ADC start1).	
		0x4	Start conversion when the edge selected by bit 27 occurs on ADCTRIG0 input (ADC start3).	
		0x5	Start conversion when the edge selected by bit 27 occurs on ADCTRIG1 input (ADC start4).	
		0x6	Start conversion when the edge selected by bit 27 occurs on Motocon PWM output MCOA2 (ADC start5).	
		0x7	Reserved.	
27	EDGE		Controls rising or falling edge on the selected signal for the start of a conversion. This bit is significant only when the START field contains 0x2-0x6).	0
		0	Rising edge.	
		1	Falling edge.	
31:28	-	-	Reserved, user software should not write ones to reserved bits. The value read from a reserved bit is not defined.	-

44.6.2 A/D Global Data register

The A/D Global Data Register contains the result of the most recent A/D conversion when the ADC operates in software-controlled, non-burst mode (BURST bit set to zero and START bits set to 0x1 in the CR register). This includes the data, DONE, and Overrun flags, and the number of the A/D channel to which the data relates.

Remark: Use only the individual channel data registers DR0 to DR7 with burst mode or with hardware triggering to read the conversion results.

Table 1024.A/D Global Data register (GDR - address 0x400E 3004 (ADC0) and 0x400E 4004 (ADC1)) bit description

Bit	Symbol	Description	Reset value
5:0	-	Reserved. These bits always read as zeroes.	0
15:6	V_VREF	When DONE is 1, this field contains a binary fraction representing the voltage on the ADCn pin selected by the SEL field, divided by the reference voltage on the VDDA pin. Zero in the field indicates that the voltage on the ADCn input pin was less than, equal to, or close to that on VSSA, while 0x3FF indicates that the voltage on ADCn input pin was close to, equal to, or greater than that on VDDA.	-
23:16	-	Reserved. These bits always read as zeroes.	0
26:24	CHN	These bits contain the channel from which the LS bits were converted.	-

Table 1024. A/D Global Data register (GDR - address 0x400E 3004 (ADC0) and 0x400E 4004 (ADC1)) bit description

Bit	Symbol	Description	Reset value
29:27	-	Reserved. These bits always read as zeroes.	0
30	OVERRUN	This bit is 1 in burst mode if the results of one or more conversions was (were) lost and overwritten before the conversion that produced the result in the V_VREF bits.	0
31	DONE	This bit is set to 1 when an analog-to-digital conversion completes. It is cleared when this register is read and when the AD0/1CR register is written. If the AD0/1CR is written while a conversion is still in progress, this bit is set and a new conversion is started.	0

44.6.3 A/D Interrupt Enable register

This register allows control over which A/D channels generate an interrupt when a conversion is complete. For example, it may be desirable to use some A/D channels to monitor sensors by continuously performing conversions on them. The most recent results are read by the application program whenever they are needed. In this case, an interrupt is not desirable at the end of each conversion for some A/D channels.

Table 1025. A/D Interrupt Enable register (INTEN - address 0x400E 300C (ADC0) and 0x400E 400C (ADC1)) bit description

Bit	Symbol	Description	Reset value
7:0	ADINTEN	These bits allow control over which A/D channels generate interrupts for conversion completion. When bit 0 is one, completion of a conversion on A/D channel 0 will generate an interrupt, when bit 1 is one, completion of a conversion on A/D channel 1 will generate an interrupt, etc.	0x00
8	ADGINTEN	When 1, enables the global DONE flag in ADDR to generate an interrupt. When 0, only the individual A/D channels enabled by ADINTEN 7:0 will generate interrupts.	1
31:9	-	Reserved. Always 0.	0

44.6.4 A/D Data Registers

The A/D Data Register hold the result when an A/D conversion is complete, and also include the flags that indicate when a conversion has been completed and when a conversion overrun has occurred.

Table 1026. A/D Data registers (DR - addresses 0x400E 3010 (DR0) to 0x400E 302C (DR7) (ADC0); 0x400E 4010 (DR0) to 0x400E 402C (DR7) (ADC1)) bit description

Bit	Symbol	Description	Reset value
5:0	-	Reserved. Always 0.	0
15:6	V_VREF	When DONE is 1, this field contains a binary fraction representing the voltage on the ADCn input pin selected in Table 1023 , divided by the voltage on the VDDA pin. Zero in the field indicates that the voltage on the ADCn input pin was less than, equal to, or close to that on VDDA, while 0x3FF indicates that the voltage on ADCn input pin was close to, equal to, or greater than that on VDDA.	-

Table 1026. A/D Data registers (DR - addresses 0x400E 3010 (DR0) to 0x400E 302C (DR7) (ADC0); 0x400E 4010 (DR0) to 0x400E 402C (DR7) (ADC1)) bit description

Bit	Symbol	Description	Reset value
29:16	-	Reserved. Always 0.	0
30	OVERRUN	This bit is 1 in burst mode if the results of one or more conversions was (were) lost and overwritten before the conversion that produced the result in the V_VREF bits in this register. This bit is cleared by reading this register.	0
31	DONE	This bit is set to 1 when an A/D conversion completes. It is cleared when this register is read.	0

44.6.5 A/D Status register

The A/D Status register allows checking the status of all A/D channels simultaneously. The DONE and OVERRUN flags appearing in the AD0/1DRn register for each A/D channel n are mirrored in ADSTAT. The interrupt flag (the logical OR of all DONE flags) is also found in ADSTAT.

Table 1027. A/D Status register (STAT - address 0x400E 3030 (ADC0) and 0x400E 4030 (ADC1)) bit description

Bit	Symbol	Description	Reset value
7:0	DONE	These bits mirror the DONE status flags that appear in the result register for each A/D channel.	0
15:8	OVERUN	These bits mirror the OVERRRUN status flags that appear in the result register for each A/D channel. Reading ADSTAT allows checking the status of all A/D channels simultaneously.	0
16	ADINT	This bit is the A/D interrupt flag. It is one when any of the individual A/D channel Done flags is asserted and enabled to contribute to the A/D interrupt via the ADINTEN register.	0
31:17	-	Reserved. Always 0.	0

44.7 Operation

44.7.1 Hardware-triggered conversion

If the BURST bit in the ADCR is 0 and the START field contains any value between 0x2 and 0x6, the A/D converter will start a conversion when a transition occurs on a selected pin or Timer signal. The choices include the two ADCTRIG external input pins, an output from the motocon PWM, and two combined timer outputs (see [Section 44.6.1](#)).

The result of a hard-ware triggered conversion is stored in the individual channel data registers DR0 to DR7. The global data register does not yield valid readings of a hardware-triggered conversion.

44.7.2 Interrupts

An interrupt is requested to the NVIC when the ADINT bit in the ADSTAT register is 1. The ADINT bit is one when any of the DONE bits of the A/D channels which are enabled for interrupts (via the ADINTEN register) are one. Software can use the Interrupt Enable bit in

the NVIC that corresponds to the ADC to control whether this results in an interrupt. The result register of the A/D channel which is generating an interrupt must be read in order to clear the corresponding DONE flag.

44.7.3 DMA control

A DMA transfer request is generated from the ADC interrupt request line. To generate a DMA transfer the same conditions must be met as the conditions for generating an interrupt. A pending DMA request is cleared after the DMA has read from the requesting channel's A/D data register (DR[7:0]). Reading from the global data register (GDR) does not clear any pending DMA requests.

For DMA transfers, only burst requests are supported. The burst size can be set to one of the predefined burst sizes in the DMA channel control register (see [Table 271](#)). If the number of ADC channels is not equal to one of the predefined DMA-supported burst sizes (applicable DMA burst sizes are 1, 4, 8), set the burst size to one.

The DMA transfer size determines when a DMA interrupt is generated. The transfer size can be set to the number of ADC channels being converted (see [Section 19.6.19](#)). Non-contiguous channels can be transferred by the DMA using the scatter/gather linked lists (see [Section 19.8.5](#)).

45.1 How to read this chapter

The DAC is available on all LPC18xx parts.

45.2 Basic configuration

The DAC is configured as follows:

- The DMA_ENA bit in the DAC control register ([Table 1032](#)) must be enabled to obtain a valid DAC output.
- See [Table 1028](#) for clocking and power control.
- The DAC is reset by the DAC_RST (reset # 42).
- The DAC interrupt is connected to interrupt slot # 0 in the NVIC.
- For connecting to the GPDMA, use the DMAMUX register ([Table 92](#)) in the CREG block and enable the GPDMA channel in the DMA Channel Configuration registers [Section 19.6.20](#).

Table 1028. DAC clocking and power control

	Base clock	Branch clock	Operating frequency	Notes
Clock to the DAC register interface and rate clock for the DMA counter.	BASE_APB3_CLK	CLK_APB3_DAC	up to 180 MHz	-

45.3 Features

- 10-bit resolution
- Monotonic by design (resistor string architecture)
- Controllable conversion speed
- Can be optimized for speed and power
- Low power consumption
- Maximum update rate of 1 MHz
- DMA support

45.4 Pin description

[Table 1029](#) gives a brief summary of each of DAC related pins.

Table 1029. DAC pin description

Pin function	Type	Description
DAC	Output	Analog Output. The voltage on this pin (with respect to V_{SSA}) is $VALUE/1024 \times VDDA$ as written to the DAC CR register (Table 1031). The DAC pin is shared with the channel 0 input pin of ADC0 and ADC1. The settling time of the DAC output can be controlled by the BIAS bit in the DAC CR register.
VDDA	Power	Analog power and voltage reference. This pin provides a voltage reference level VREF for the D/A converter.
VSSA	-	Ground.

45.5 Register description

Table 1030. Register overview: DAC (base address 0x400E 1000)

Name	Access	Address offset	Description	Reset value	Reference
CR	R/W	0x000	DAC register. Holds the conversion data.	0	Table 1031
CTRL	R/W	0x004	DAC control register.	0	Table 1032
CNTVAL	R/W	0x008	DAC counter value register.	0	Table 1033

45.5.1 D/A converter register

This read/write register includes the digital value to be converted to an analog output value and a bit that trades off performance vs. power.

Table 1031: D/A Converter register (CR - address 0x400E 1000) bit description

Bit	Symbol	Value	Description	Reset value
5:0	-		Reserved, user software should not write ones to reserved bits. The value read from a reserved bit is not defined.	-
15:6	VALUE		Once this field is written with a new VALUE, the voltage on the DAC pin (with respect to V_{SSA}) is $VALUE/1024 \times VDDA$. The value of the DAC output pin is valid after the selected settling time (see the BIAS bit in this register) has expired.	0
16	BIAS		Settling time	0
		0	Shorter settling times and higher power consumption; allows for a maximum update rate of 1 MHz.	
		1	Longer settling times and lower power consumption; allows for a maximum update rate of 400 kHz.	
31:17	-		Reserved, user software should not write ones to reserved bits. The value read from a reserved bit is not defined.	-

45.5.2 D/A Converter Control register

This read/write register enables the DMA operation and controls the DMA timer.

Table 1032.D/A Control register (CTRL - address 0x400E 1004) bit description

Bit	Symbol	Value	Description	Reset value
0	INT_DMA_REQ		DMA request	0
		0	This bit is cleared on any write to the DAC CR register.	
		1	This bit is set by hardware when the timer times out.	
1	DBLBUF_ENA		DMA double-buffering	0
		0	Disable double-buffering.	
		1	Enable double-buffering. When this bit and the CNT_ENA bit are both set, the double-buffering feature in the DAC CR register will be enabled. Writes to the DAC CR register are written to a pre-buffer and then transferred to the DAC CR on the next time-out of the counter.	
2	CNT_ENA		DMA time-out	0
		0	Time-out counter operation is disabled.	
		1	Time-out counter operation is enabled.	
3	DMA_ENA		Combined DAC enable and DMA enable. When the DMA_ENA bit is cleared (default state after reset), DAC DMA requests are blocked and the DAC output is disabled.	0
		0	Disable DAC/DMA.	
		1	Enable DAC and enable DMA Burst Request Input 15 (see Table 252).	
31:4	-		Reserved, user software should not write ones to reserved bits. The value read from a reserved bit is not defined.	-

45.5.3 D/A Converter Counter Value register

This read/write register contains the reload value for the Interrupt/DMA counter.

Table 1033:D/A Converter counter value register (CNTVAL - address 0x400E 1008) bit description

Bit	Symbol	Description	Reset value
15:0	VALUE	16-bit reload value for the DAC interrupt/DMA timer.	0
31:16	-	Reserved.	-

45.6 Functional description

45.6.1 DMA counter

When the counter enable bit CNT_ENA in DAC CTRL register is set, a 16-bit counter will begin counting down, at the rate selected by CLK_APB3_DAC, from the value programmed into the DAC CNTVAL register. The counter is decremented each time the counter reaches zero, the counter will be reloaded by the value of the DAC CNTVAL register, and the DMA request bit INT_DMA_REQ will be set in hardware.

Note that the contents of the DAC CTRL and DAC CNTVAL registers are read and write accessible, but the timer itself is not accessible for either read or write.

If the DMA_ENA bit is set in the DAC CTRL register, the DAC DMA request will be routed to the GPDMA. When the DMA_ENA bit is cleared, the default state after a reset, DAC DMA requests are blocked.

45.6.2 Double buffering

Double-buffering is enabled only if both, the CNT_ENA and the DBLBUF_ENA bits are set in DAC CTRL. In this case, any write to the DAC CR register will only load the pre-buffer, which shares its register address with the DAC CR register. The DAC CR itself will be loaded from the pre-buffer whenever the counter reaches zero and the DMA request is set. At the same time the counter is reloaded with the CNTVAL register value.

Reading the DAC CR register will only return the contents of the DAC CR register itself, not the contents of the pre-buffer register.

If either the CNT_ENA or the DBLBUF_ENA bits are 0, any writes to the DAC CR address will go directly to the DAC CR register.

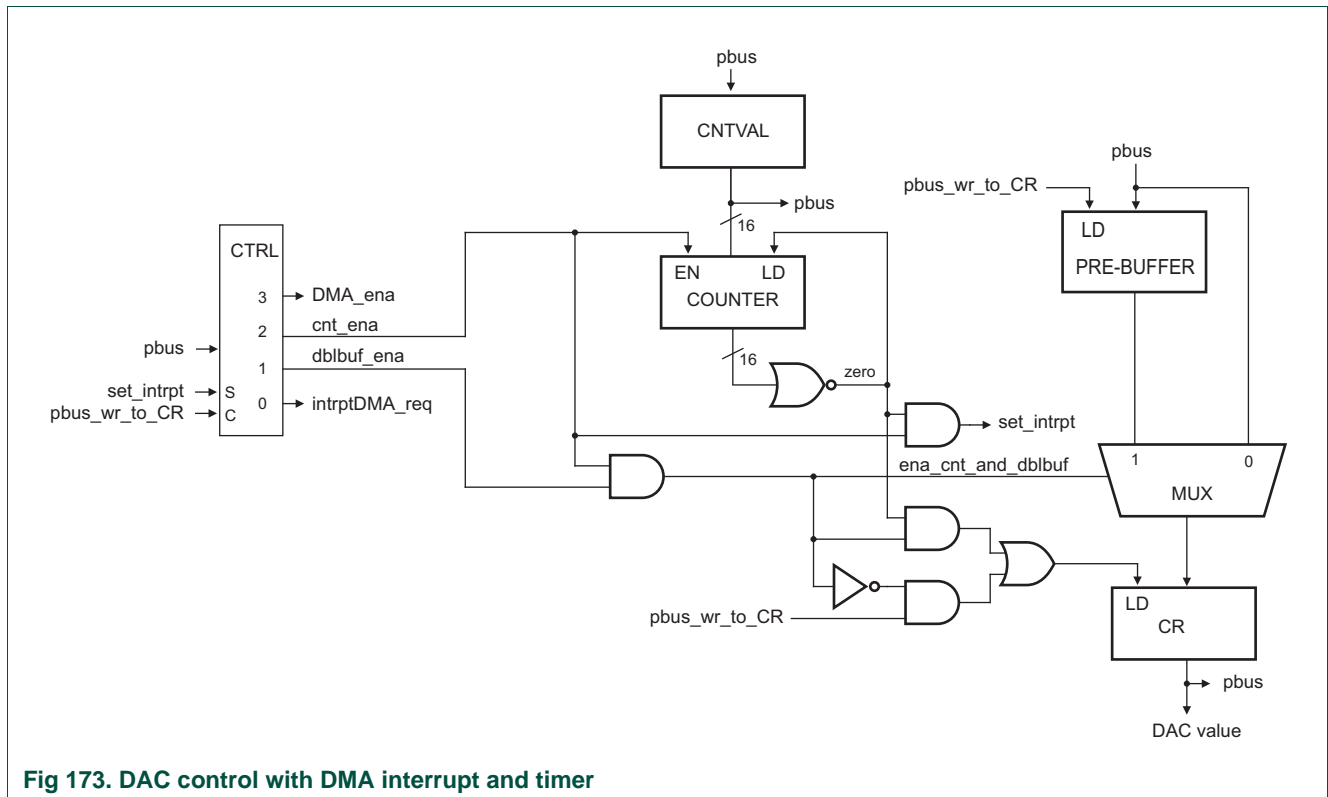

Fig 173. DAC control with DMA interrupt and timer

46.1 How to read this chapter

The EEPROM is available on all parts with on-chip flash.

46.2 Basic configuration

The EEPROM is configured using the following registers:

- See [Table 1034](#) for clocking and power control.
- The EEPROM is reset by the EEPROM_RST (reset # 27).
- The EEPROM interrupt is ORed with the interrupts from flash banks A and B and connected to interrupt slot #4 in the NVIC.

Table 1034. EEPROM clocking and power control

	Base clock	Branch clock	Operating frequency
EEPROM	BASE_M3_CLK	CLK_M3_EEPROM	up to 180 MHz

46.3 Features

- Up to 16384 byte EEPROM
- Access via memory on the AHB bus
- Less than 3 ms erase / program time
- Endurance of > 100 k erase / program cycles

46.4 General description

The EEPROM can be read and written/erased. A write operation involves two steps. The first step is writing a minimum of 1 word (4 bytes) to a maximum of 32 words (128 bytes) to the desired page in the 16 kB EEPROM address space at address 0x2004 0000. Step two is an erase/program of that page into non-volatile memory. There are 128 pages within the 16 kB EEPROM address space. The last page contains the EEPROM initialization data and is not writable. Note that data written to a page cannot be read back from the page address until the data have been programmed into non-volatile memory.

46.5 Register description

Table 1035. Register overview: EEPROM (base address 0x4000 E000)

Name	Access	Address offset	Description	Reset value ^[1]	Reference
EEPROM registers					
CMD	R/W	0x000	EEPROM command register	0	Table 1036
RWSTATE	R/W	0x008	EEPROM read wait state register	0x0000 0E07	Table 1037
AUTOPROG	R/W	0x00C	EEPROM auto programming register	0	Table 1038
WSTATE	R/W	0x010	EEPROM wait state register	0x0004 0802	Table 1039
CLKDIV	R/W	0x014	EEPROM clock divider register	0x0000 0063	Table 1040
PWRDWN	R/W	0x018	EEPROM power-down register	0	Table 1041
EEPROM interrupt registers:					
INTENCLR	WO	0xFD8	EEPROM interrupt enable clear	0	Table 1042
INTENSET	WO	0xFDC	EEPROM interrupt enable set	0	Table 1043
INTSTAT	RO	0xFE0	EEPROM interrupt status	0	Table 1044
INTEN	RO	0xFE4	EEPROM interrupt enable	0	Table 1045
INTSTATCLR	WO	0xFE8	EEPROM interrupt status clear	0	Table 1046
INTSTATSET	WO	0xFEC	EEPROM interrupt status set	0	Table 1047

[1] Reset Value reflects the data stored in used bits only. It does not include reserved bits content.

46.5.1 EEPROM control registers

46.5.1.1 EEPROM command register

The EEPROM command register is used to trigger an erase/program operation on the EEPROM device.

Table 1036. EEPROM command register (CMD - address 0x4000 E000) bit description

Bits	Symbol	Description	Reset value
2:0	CMD	Command. Read data shows the last command executed on the EEPROM. 110 = erase/program page All other values are reserved.	0
31:3	-	Reserved. Read value is undefined, only zero should be written.	NA

46.5.1.2 EEPROM read wait state register

The EEPROM has no awareness of absolute time, while for EEPROM operations several minimum absolute timing constraints have to be met. Therefore the EEPROM can only derive time from its clock by frequency division.

The EEPROM read wait state register is used to define wait states for the AHB read operation in functional mode only. In JTAG mode the PHASE1 and PHASE2 fields of the EEPROM wait state register EEWSTATE are used.

Program the wait state fields to appropriate values in this wait state register for EEPROM operation. The fields are -1 encoded, so programming zero will result in a one cycle wait state.

The register contains two fields, each representing a minimum duration of a phase of the EEPROM read. The appropriate values for each field are determined as follows:

$$(\text{waitstates} + 1) \times T_{\text{clk}} \geq \text{duration}$$

Table 1037. EEPROM read wait state register (RWSTATE - address 0x4000 E008) bit description

Bits	Symbol	Description	Reset value
7:0	RPHASE2	Wait states 2 (minus 1 encoded). The number of system clock periods to meet the read operations TRPHASE2 duration.	0x07
15:8	RPHASE1	Wait states 1 (minus 1 encoded). The number of system clock periods to meet a duration equal to TRPHASE1.	0x0E
31:16	-	Reserved. Read value is undefined, only zero should be written.	NA

46.5.1.3 EEPROM auto programming register

The auto programming register allows the user to let the controller start an erase/program cycle automatically after AHB writes without the need to program the CMD register after the page register has been written.

Table 1038. EEPROM auto programming register (AUTOPROG - address 0x4000 E00C) bit description

Bits	Symbol	Description	Reset value
1:0	AUTOPROG	Auto programming mode: 00 = auto programming off 01 = erase/program cycle is triggered after 1 word is written 10 = erase/program cycle is triggered after a write to AHB address ending with1111100 (last word of a page)	0
31:2	-	Reserved. Read value is undefined, only zero should be written.	NA

46.5.1.4 EEPROM wait state register

The EEPROM has no awareness of absolute time, while for EEPROM operations several minimum absolute timing constraints have to be met. Therefore the EEPROM can only derive time from its clock by frequency division.

Program the wait state fields to appropriate values in this wait state register for EEPROM operation. The fields are -1 encoded so programming zero will result in a one cycle wait state.

The fields in the WAITSTATE register represent a minimum duration of a phase of the EEPROM operation. The appropriate wait state values for each fields are determined as follows:

$$(\text{waitstates} + 1) \times T_{\text{clk}} \geq \text{duration}$$

The delays for the write and erase/program operations are combined to simplify the software interface. Timing for write and erase/program operations is almost identical.

Table 1039. EEPROM wait state register (WSTATE - address 0x4000 E010) bit description

Bits	Symbol	Description	Reset value
7:0	PHASE3	Wait states for phase 3 (minus 1 encoded). The number of system clock periods to meet a duration equal to TPHASE3.	0x2
15:8	PHASE2	Wait states for phase 2 (minus 1 encoded). The number of system clock periods to meet a duration equal to TPHASE2.	0x8
23:16	PHASE1	Wait states for phase 1 (minus 1 encoded). The number of system clock periods to meet a duration equal to TPHASE1.	0x4
30:24	-	Reserved. Read value is undefined, only zero should be written.	NA
31	LCK_PARWEP	Lock timing parameters for write, erase and program operation 0 = WSTATE and CLKDIV registers have R/W access 1 = WSTATE and CLKDIV registers have R only access	0

46.5.1.5 EEPROM clock divider register

The EEPROM device requires a 1500 kHz clock. The nominal value of the frequency is 1500 kHz, the lower limit is 800 kHz, the maximum limit is 1600 kHz.

This clock is generated by dividing the system bus clock. The clock divider register contains the division factor.

If the division factor is 0, the clock is be IDLE to save power.

$$\frac{cclk}{CLKDIV + 1} \approx 1500kHz$$

Table 1040. EEPROM clock divider register (CLKDIV - address 0x4000 E014) bit description

Bits	Symbol	Description	Reset value
15:0	CLKDIV	Division factor (minus 1 encoded).	-
31:16	-	Reserved. Read value is undefined, only zero should be written.	NA

46.5.1.6 EEPROM power down register

Use the EEPROM power down register to put the EEPROM device in power down mode.

Do not put the EEPROM in power-down mode during a pending EEPROM operation. After clearing this bit any EEPROM operation has to be suspended for 100 μs while the EEPROM wakes up.

Table 1041. EEPROM power down register (PWRDWN - address 0x4000 E018) bit description

Bits	Symbol	Description	Reset value
0	PWRDWN	Power down mode bit. 0 = not in power down mode. 1 = power down mode.	0
31:1	-	Reserved. Read value is undefined, only zero should be written.	NA

46.5.2 Interrupt registers

These registers control interrupts from the EEPROM.

46.5.2.1 Interrupt enable clear register

Table 1042. Interrupt enable clear register (INTENCLR - address 0x4000 EFD8) bit description

Bits	Symbol	Description	Reset value
1:0	-	Reserved. Read value is undefined, only zero should be written.	NA
2	PROG_CLR_EN	Clear program operation finished interrupt enable bit for EEPROM. 0 = leave corresponding bit unchanged. 1 = clear corresponding bit.	0
31:3	-	Reserved. Read value is undefined, only zero should be written.	NA

46.5.2.2 Interrupt enable set register

Table 1043. Interrupt enable set register (INTENSET - address 0x4000 EFD8) bit description

Bits	Symbol	Description	Reset value
1:0	-	Reserved. Read value is undefined, only zero should be written.	NA
2	PROG_SET_EN	Set program operation finished interrupt enable bit for EEPROM device 1. 0 = leave corresponding bit unchanged. 1 = set corresponding bit.	0
31:3	-	Reserved. Read value is undefined, only zero should be written.	NA

46.5.2.3 Interrupt status register

Table 1044. Interrupt status register (INTSTAT - address 0x4000 EFE0) bit description

Bits	Symbol	Description	Reset value
1:0	-	Reserved. The value read from a reserved bit is not defined.	NA
2	END_OF_PROG	EEPROM program operation finished interrupt status bit. Bit is: - set when this operation has finished OR when one is written to the corresponding bit of the INTSTATSET register. - cleared when one is written to the corresponding bit of the INTSTATCLR register.	0
31:3	-	Reserved. The value read from a reserved bit is not defined.	NA

46.5.2.4 Interrupt enable register

Table 1045. Interrupt enable register (INTEN - address 0x4000 EFE4) bit description

Bits	Symbol	Description	Reset value
1:0	-	Reserved. The value read from a reserved bit is not defined.	NA
2	EE_PROG_DONE	EEPROM program operation finished interrupt enable bit. Bit is: - set when one is written in the corresponding bit of the INTENSET register. - cleared when one is written to the corresponding bit of the INTENCLR register.	0
31:3	-	Reserved. The value read from a reserved bit is not defined.	NA

46.5.2.5 Interrupt status clear register

Table 1046. Interrupt status clear register (INTSTATCLR - address 0x4000 EFE8) bit description

Bits	Symbol	Description	Reset value
1:0	-	Reserved. Read value is undefined, only zero should be written.	NA
2	PROG_CLR_ST	Clear program operation finished interrupt status bit for EEPROM device. 0 = leave corresponding bit unchanged. 1 = clear corresponding bit.	0
31:3	-	Reserved. Read value is undefined, only zero should be written.	NA

46.5.2.6 Interrupt status set

Table 1047. Interrupt status set register (INTSTATSET - address 0x4000 EFEC)

Bits	Symbol	Description	Reset value
1:0	-	Reserved. Read value is undefined, only zero should be written.	NA
2	PROG_SET_ST	Set program operation finished interrupt status bit for EEPROM device. 0 = leave corresponding bit unchanged. 1 = set corresponding bit.	0
31:3	-	Reserved. Read value is undefined, only zero should be written.	NA

46.6 Functional description

46.6.1 Initialization

At power-up, the reset should be applied for at least 100us. However a normal reset (not at power-up) period is only 40 ns.

After the reset period the controller initializes the EEPROM by reading the first word (containing trimming information) of the last (protected) page of the EEPROM. The information that is read is used as input values of the EEPROM device and is ignored by the controller and not visible on the APB bus.

During the EEPROM reset and initialization any started AHB/APB transfer will stall the bus.

46.6.2 EEPROM operations

An EEPROM device cannot be programmed directly. Writing data to it and the actual erase/program of the memory are two separate steps.

1. Write 1 word (4 bytes) to 32 words (128 bytes) to the desired page in the 16 kB EEPROM address space. There are 128 pages in the 16 kB EEPROM address space. Page 1 begins at the first address of the EEPROM address space (EEPROM_START = 0x2004 0000). Page 2 begins at EEPROM_START + 128, page 3 begins at EEPROM_START + 256, etc. Writes to a page cannot cross a 128 page boundary.

Remark: Before reading this data from the EEPROM or writing to another page, program the contents of the page register into the EEPROM.

2. Program the data into the EEPROM with the erase/program command issued via the EEPROM CMD register on the APB.

46.6.2.1 Writing and erase/programming

Writing an EEPROM page is achieved by AHB writes.

Partial page writes are allowed, and the EEPROM will only take locations where a word has been written for the erase/program cycle. Any word in a page can be written in any order, but every word in the page may only be written once.

The address of the AHB transfer prior to the erase/program cycle will determine the page address for the erase/program cycle.

The following modes are supported for the write and erase/programming operation:

- AUTOPROG = 00: When the page has been written (fully or partially), the data has to be programmed into non-volatile memory. The erase/program cycle is triggered by writing 0x6 to the CMD register. The page that is programmed is determined by the address of the last AHB transfer. Therefore it is advised to perform a page write with the page address and to prevent AHB reads between page register writes and the erase/program trigger.
- AUTOPROG = 01: Writing a single word to the page starts the erase/program cycle automatically. This mode is useful store small data items (word) on random locations.

- AUTOPROG = 10: Writing to the last word of the page register (AHB address ending with 1111100) automatically starts the erase/program cycle. This mode is useful to store multiple full pages of data.

During programming, the EEPROM is not available for other operations. To prevent undesired loss in performance which would be caused by stalling the bus, the EEPROM instead generates an error for AHB read/writes and APB writes when programming is busy. In order to prevent the error response, the program operation finished interrupt can be enabled or the interrupt status bit can be polled.

47.1 How to read this chapter

The debug functions are identical on all LPC18xx parts. The parallel trace port is not available on the 100-pin packages.

47.2 Basic configuration

- Select between Debug modes:
 - When the DBGEN pin is HIGH, the ARM debug mode is entered.
 - When the DBGEN pin is LOW, JTAG BSDL is entered.
- The core frequency must be 120 MHz or lower to use the SWO function.
- The ETM trace capture speed is limited by the trace pin properties. The maximum speed is 120 MHz when the EHS bit is set in the pin configuration register for the multiplexed trace pins ([Table 174](#)).
- Enable ETB SRAM in the CREG block (see [Section 10.4.8](#)).

47.3 Features

- Supports both standard JTAG and ARM Serial Wire Debug modes.
- Direct debug access to all memories, registers, and peripherals.
- No target resources are required for the debugging session.
- Trace port provides CPU instruction trace capability. Output can be via a 4-bit trace data port, or Serial Wire Viewer.
- ETM time stamping is not implemented.
- Six instruction breakpoints that can also be used to remap instruction addresses for code patches. Two data comparators that can be used to remap addresses for patches to literal values.
- Four data Watchpoints that can also be used as trace triggers.
- Instrumentation Trace Macrocell allows additional software controlled trace.

47.4 General Description

Debug and trace functions are integrated into the ARM Cortex-M3. Serial wire debug and trace functions are supported in addition to a standard JTAG debug and parallel trace functions. The ARM Cortex-M3 is configured to support up to eight breakpoints and four watchpoints.

Debugging with the LPC18xx defaults to JTAG. Once in the JTAG debug mode, the debug tool can switch to Serial Wire Debug mode.

Trace can be performed using either a 4-bit parallel interface or the Serial Wire Output.

47.4.1 Embedded Trace Macrocell (ETM)

Trace can be performed using either a 4-bit parallel interface or the Serial Wire Output.

The ETM Trace port provides CPU instruction trace capability using the ETB memory. To access the ETB memory, enable the ETB SRAM in the CREG block (see [Section 10.4.8](#)).

Remark: The ETM time stamping feature is not implemented.

47.5 Pin Description

[Table 1048](#) to [Table 1050](#) indicate the various pin functions related to debug and trace. Some of these functions share pins with other functions which therefore may not be used at the same time. Use of the JTAG port excludes use of Serial Wire Debug and Serial Wire Output. Use of the parallel trace requires five pins that may be part of the user application, limiting debug possibilities for those features. Trace using the Serial Wire Output does not have this limitation but the bandwidth is limited.

Table 1048. JTAG pin description

Pin Name	Type	Description
TCK	Input	JTAG Test Clock. This pin is the clock for debug logic when in the JTAG debug mode.
TMS	Input	JTAG Test Mode Select. The TMS pin selects the next state in the TAP state machine.
TDI	Input	JTAG Test Data In. This is the serial data input for the shift register.
TDO	Output	JTAG Test Data Output. This is the serial data output from the shift register. Data is shifted out of the device on the negative edge of the TCK signal.
$\overline{\text{TRST}}$	Input	JTAG Test Reset. The $\overline{\text{TRST}}$ pin can be used to reset the test logic within the debug logic.

Table 1049. Serial Wire Debug pin description

Pin Name	Type	Description
SWDCLK	Input	Serial Wire Clock. This pin is the clock for debug logic when in the Serial Wire Debug mode.
SWDIO	Input / Output	Serial wire debug data input/output. The SWDIO pin is used by an external debug tool to communicate with and control the Cortex-M3 CPU.
SWO	Output	Serial Wire Output. The SWO pin optionally provides data from the ITM and/or the ETM for an external debug tool to evaluate. Remark: The core frequency must be 120 MHz or lower to use the SWO.

Table 1050.Parallel Trace pin description

Pin Name	Type	Description
TRACECLK	Input	Trace Clock. This pin provides the sample clock for trace data on the TRACEDATA pins when tracing is enabled by an external debug tool.
TRACEDATA[3:0]	Output	Trace Data bits 3 to 0. These pins provide ETM trace data when tracing is enabled by an external debug tool. The debug tool can then interpret the compressed information and make it available to the user.

47.6 Debug connections

The LPC18xx supplies dedicated pins for JTAG and Serial Wire Debug (SWD). When a debug session is started, the part will be in JTAG debug mode. Once in debug mode, the debugger can switch the device to SWD mode.

Connections from a target board to the debugger can vary. Selecting a debug connector to add to a new board design depends on the debug tools that will be used.

47.6.1 ARM Standard JTAG connector (20-pin)

Figure 174 shows a standard JTAG connector. The ARM Standard JTAG Connector provides support for Serial Wire and JTAG interface modes in a 20-pin (0.1") connector. It can be used to access all SWD, SWV, and JTAG signals.

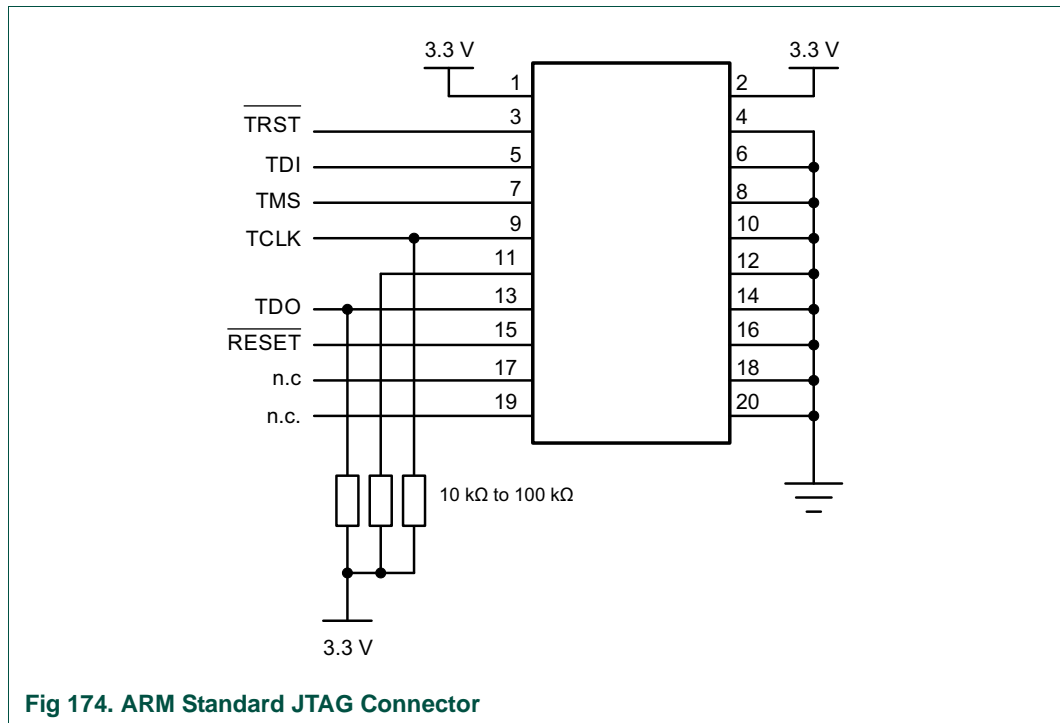

Fig 174. ARM Standard JTAG Connector

47.6.2 Cortex debug connector (10-pin)

Figure 175 shows the Cortex debug connector (10-pin). This connector provides support for Serial Wire and JTAG in a very small connector. The 10-pin Cortex debug connector can access to all SWD, SWV, and JTAG signals.

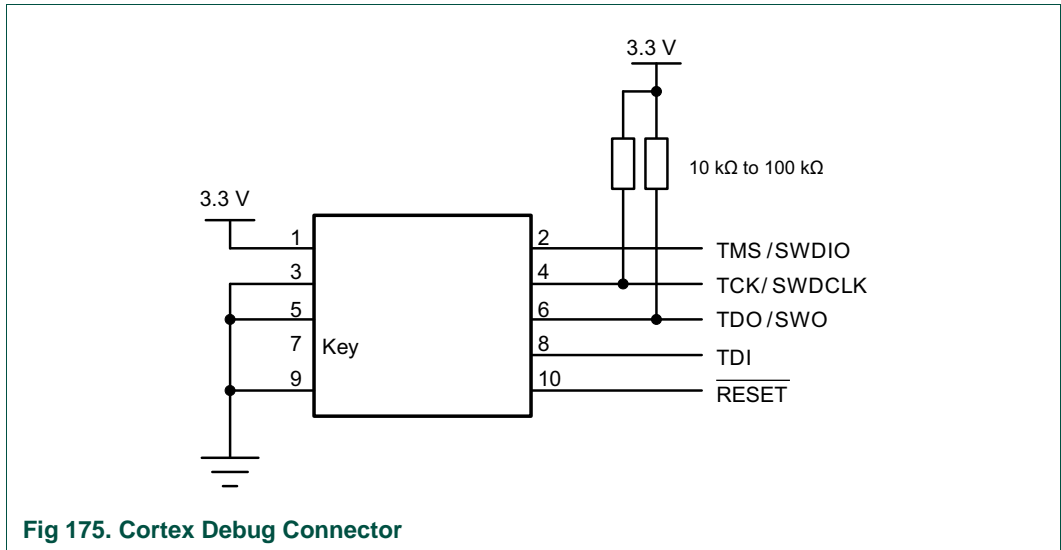

Fig 175. Cortex Debug Connector

47.6.3 Cortex Debug + ETM connector (20-pin)

If the debug trace feature will be used, there is also a debug-with-trace connector specification as shown in Figure 176. This small 20-pin (0.05") connector provides access to SWD, SWV, JTAG, and ETM (4-bit) signals.

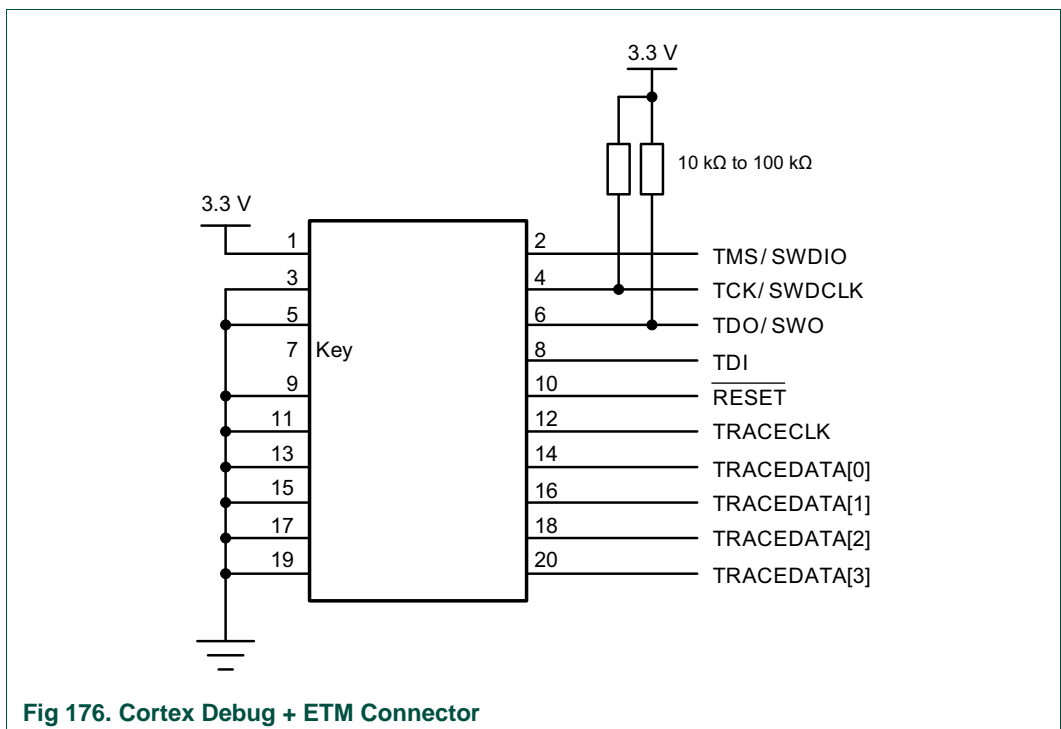

Fig 176. Cortex Debug + ETM Connector

47.7 Debug Notes

The following limitations apply during debugging:

- Due to limitations of the Cortex-M3 integration, the LPC18xx cannot wake up in the usual manner from Deep Sleep and Power-down modes. It is recommended not to use these modes during debug.
- The debug mode changes the way in which reduced power modes are handled by the Cortex-M3 CPU. This causes power modes at the device level to be different from normal mode operation. These differences mean that power measurements should not be made while debugging, the results will be higher than during normal operation in an application.
- During a debugging session, the System Tick Timer and the Repetitive Interrupt Timers are automatically stopped whenever the CPU is stopped. Other peripherals are not affected. If the Repetitive Interrupt Timer is configured such that its clock rate is lower than the CPU clock rate, the RIT may not increment predictably during some debug operations, such as single stepping.
- Debugging is disabled if code read protection is enabled.

47.8 Debug memory re-mapping

Following chip reset, a portion of the Boot ROM is mapped to address 0 so that it will be automatically executed. The Boot ROM switches the map to point to 0x1000 0000 or 0x1C00 0000 (when booting from EMC) or 0x8000 0000 (when booting from SPIFI). Code execution can start from address 0x0000 0000 using the ARM Cortex-M3 memory mapping register ([Table 90](#)).

The register mapping is normally not transparent to the user. However, when a debugger halts CPU execution immediately following reset, the Boot ROM is still mapped to address 0 and the IRC calibration value has not been loaded, which may cause the IRC frequency to be outside of the specified 12 MHz. Ideally, the debugger should correct the mapping automatically in this case.

47.9 JTAG TAP Identification

The JTAG TAP controller contains a device ID that can be used by debugging software to identify the general type of device.

Table 1051. JTAG TAP identification

Mode	ID code
JTAG mode	0x4BA0 0477
SWD mode	0x2BA0 1477

48.1 How to read this chapter

This chapter contains a list of errors that can be returned by the ROM APIs. For a description of the ROM APIs see:

- [Chapter 6 “LPC18xx Security API”](#)
- [Chapter 3 “LPC18xx One-Time Programmable \(OTP\) memory and API”](#)
- [Chapter 5 “LPC18xx flash programming/ISP and IAP”](#)
- [Chapter 25 “LPC18xx USB API”](#)

48.2 Error codes

```
ERR_ISP_BASE = 0x00000000,
/*0x00000001*/ ERR_ISP_INVALID_COMMAND = ERR_ISP_BASE + 1,
/*0x00000002*/ ERR_ISP_SRC_ADDR_ERROR, /* Source address not on word boundary */
/*0x00000003*/ ERR_ISP_DST_ADDR_ERROR, /* Destination address not on word or 256 byte boundary */
/*0x00000004*/ ERR_ISP_SRC_ADDR_NOT_MAPPED,
/*0x00000005*/ ERR_ISP_DST_ADDR_NOT_MAPPED,
/*0x00000006*/ ERR_ISP_COUNT_ERROR, /* Byte count is not multiple of 4 or is not a permitted value */
/*0x00000007*/ ERR_ISP_INVALID_SECTOR,
/*0x00000008*/ ERR_ISP_SECTOR_NOT_BLANK,
/*0x00000009*/ ERR_ISP_SECTOR_NOT_PREPARED_FOR_WRITE_OPERATION,
/*0x0000000A*/ ERR_ISP_COMPARE_ERROR,
/*0x0000000B*/ ERR_ISP_BUSY, /* Flash programming hardware interface is busy */
/*0x0000000C*/ ERR_ISP_PARAM_ERROR, /* Insufficient number of parameters */
/*0x0000000D*/ ERR_ISP_ADDR_ERROR, /* Address not on word boundary */
/*0x0000000E*/ ERR_ISP_ADDR_NOT_MAPPED,
/*0x0000000F*/ ERR_ISP_CMD_LOCKED, /* Command is locked */
/*0x00000010*/ ERR_ISP_INVALID_CODE, /* Unlock code is invalid */
/*0x00000011*/ ERR_ISP_INVALID_BAUD_RATE,
/*0x00000012*/ ERR_ISP_INVALID_STOP_BIT,
/*0x00000013*/ ERR_ISP_CODE_READ_PROTECTION_ENABLED,
/*0x00000014*/ ERR_ISP_INVALID_FLASH_UNIT,
/*0x00000015*/ ERR_ISP_USER_CODE_CHECKSUM,
/*0x00000016*/ ERR_ISP_SETTING_ACTIVE_PARTITION,
/*0x00000017*/ ERR_ISP_IRC_NO_POWER,
/*0x00000018*/ ERR_ISP_FLASH_NO_POWER,
/*0x00000019*/ ERR_ISP_EEPROM_NO_POWER,
/*0x0000001A*/ ERR_ISP_EEPROM_NO_CLOCK,
/*0x0000001B*/ ERR_ISP_FLASH_NO_CLOCK,

/* ROM API related errors */
ERR_API_BASE = 0x00010000,
/**\b 0x00010001*/ ERR_API_INVALID_PARAMS = ERR_API_BASE + 1, /**< Invalid parameters*/
/**\b 0x00010002*/ ERR_API_INVALID_PARAM1, /**< PARAM1 is invalid */
/**\b 0x00010003*/ ERR_API_INVALID_PARAM2, /**< PARAM2 is invalid */
```



```

/**\b 0x00010004*/ ERR_API_INVALID_PARAM3, /**< PARAM3 is invalid */
/**\b 0x00010005*/ ERR_API_MOD_INIT, /**< API is called before module init */
/* SPIFI API related errors */
ERR_SPIFI_BASE = 0x00020000,
/*0x00020001*/ ERR_SPIFI_DEVICE_ERROR =ERR_SPIFI_BASE+1,
/*0x00020002*/ ERR_SPIFI_INTERNAL_ERROR,
/*0x00020003*/ ERR_SPIFI_TIMEOUT,
/*0x00020004*/ ERR_SPIFI_OPERAND_ERROR,
/*0x00020005*/ ERR_SPIFI_STATUS_PROBLEM,
/*0x00020006*/ ERR_SPIFI_UNKNOWN_EXT,
/*0x00020007*/ ERR_SPIFI_UNKNOWN_ID,
/*0x00020008*/ ERR_SPIFI_UNKNOWN_TYPE,
/*0x00020009*/ ERR_SPIFI_UNKNOWN_MFG,
/*0x0002000A*/ ERR_SPIFI_NO_DEVICE,
/*0x0002000B*/ ERR_SPIFI_ERASE_NEEDED,
SEC_AES_NO_ERROR=0,
/* Security API related errors */
ERR_SEC_AES_BASE = 0x00030000,
/*0x00030001*/ ERR_SEC_AES_WRONG_CMD=ERR_SEC_AES_BASE+1,
/*0x00030002*/ ERR_SEC_AES_NOT_SUPPORTED,
/*0x00030003*/ ERR_SEC_AES_KEY_ALREADY_PROGRAMMED,
/*0x00030004*/ ERR_SEC_AES_DMA_CHANNEL_CFG,
/*0x00030005*/ ERR_SEC_AES_DMA_MUX_CFG,
/*0x00030006*/ SEC_AES_DMA_BUSY,
/* USB device stack related errors */
ERR_USBD_BASE = 0x00040000,
/**\b 0x00040001*/ ERR_USBD_INVALID_REQ = ERR_USBD_BASE + 1, /**< invalid request */
/**\b 0x00040002*/ ERR_USBD_UNHANDLED, /**< Callback did not process the event */
/**\b 0x00040003*/ ERR_USBD_STALL, /**< Stall the endpoint on which the call back is called */
/**\b 0x00040004*/ ERR_USBD_SEND_ZLP, /**< Send ZLP packet on the endpoint on which the call back is called */
/**\b 0x00040005*/ ERR_USBD_SEND_DATA, /**< Send data packet on the endpoint on which the call back is called
*/
/**\b 0x00040006*/ ERR_USBD_BAD_DESC, /**< Bad descriptor*/
/**\b 0x00040007*/ ERR_USBD_BAD_CFG_DESC,/**< Bad config descriptor*/
/**\b 0x00040008*/ ERR_USBD_BAD_INTF_DESC,/**< Bad interface descriptor*/
/**\b 0x00040009*/ ERR_USBD_BAD_EP_DESC,/**< Bad endpoint descriptor*/
/**\b 0x0004000a*/ ERR_USBD_BAD_MEM_BUF, /**< Bad alignment of buffer passed. */
/**\b 0x0004000b*/ ERR_USBD_TOO_MANY_CLASS_HDLR, /**< Too many class handlers. */
/* CGU related errors */
ERR_CGU_BASE = 0x00050000,
/*0x00050001*/ ERR_CGU_NOT_IMPL=ERR_CGU_BASE+1,
/*0x00050002*/ ERR_CGU_INVALID_PARAM,
/*0x00050003*/ ERR_CGU_INVALID_SLICE,
/*0x00050004*/ ERR_CGU_OUTPUT_GEN,
/*0x00050005*/ ERR_CGU_DIV_SRC,
/*0x00050006*/ ERR_CGU_DIV_VAL,
/*0x00050007*/ ERR_CGU_SRC,
/* OTP related errors */
ERR_OTP_BASE = 0x00070000,
/*0x00070001*/ ERR_OTP_WR_ENABLE_INVALID = ERR_OTP_BASE+1,
/*0x00070002*/ ERR_OTP_SOME_BITS_ALREADY_PROGRAMMED,

```

```
/*0x00070003*/ ERR_OTP_ALL_DATA_OR_MASK_ZERO,  
/*0x00070004*/ ERR_OTP_WRITE_ACCESS_LOCKED,  
/*0x00070005*/ ERR_OTP_READ_DATA_MISMATCH,  
/*0x00070006*/ ERR_OTP_USB_ID_ENABLED,  
/*0x00070007*/ ERR_OTP_ETH_MAC_ENABLED,  
/*0x00070008*/ ERR_OTP_AES_KEYS_ENABLED,  
/*0x00070009*/ ERR_OTP_ILLEGAL_BANK,  
/* CLK related errors */  
ERR_CLK_BASE = 0x000B0000,  
/*0x000B0001*/ ERR_CLK_NOT_IMPL=ERR_CLK_BASE+1,  
/*0x000B0002*/ ERR_CLK_INVALID_PARAM,  
/*0x000B0003*/ ERR_CLK_INVALID_SLICE,  
/*0x000B0004*/ ERR_CLK_OUTPUT_GEN,  
/*0x000B0005*/ ERR_CLK_DIV_SRC,  
/*0x000B0006*/ ERR_CLK_DIV_VAL,  
/*0x000B0007*/ ERR_CLK_SRC,  
/*0x000B0008*/ ERR_CLK_PLL_FIN_TOO_SMALL,  
/*0x000B0009*/ ERR_CLK_PLL_FIN_TOO_LARGE,  
/*0x000B000A*/ ERR_CLK_PLL_FOUT_TOO_SMALL,  
/*0x000B000B*/ ERR_CLK_PLL_FOUT_TOO_LARGE,  
/*0x000B000C*/ ERR_CLK_PLL_NO_SOLUTION,  
/*0x000B000D*/ ERR_CLK_PLL_MIN_PCT,  
/*0x000B000E*/ ERR_CLK_PLL_MAX_PCT,  
/*0x000B000F*/ ERR_CLK_OSC_FREQ,  
/*0x000B0010*/ ERR_CLK_CFG,  
/*0x000B0011*/ ERR_CLK_TIMEOUT,  
/*0x000B0012*/ ERR_CLK_BASE_OFF,  
/*0x000B0013*/ ERR_CLK_OFF_DEADLOCK,
```

49.1 Abbreviations

Table 1052. Abbreviations

Acronym	Description
ADC	Analog-to-Digital Converter
AES	Advanced Encryption Standard
AHB	Advanced High-performance Bus
APB	Advanced Peripheral Bus
API	Application Programming Interface
BOD	BrownOut Detection
CAN	Controller Area Network
CMAC	Cipher-based Message Authentication Code
CSMA/CD	Carrier Sense Multiple Access with Collision Detection
DAC	Digital-to-Analog Converter
DC-DC	Direct Current-to-Direct Current
DMA	Direct Memory Access
FIPS	Federal Information Processing Standard
GPIO	General Purpose Input/Output
IRC	Internal RC
IrDA	Infrared Data Association
JTAG	Joint Test Action Group
LCD	Liquid Crystal Display
LSB	Least Significant Bit
MAC	Media Access Control
MCU	MicroController Unit
MIIM	Media Independent Interface Management
n.c.	not connected
NIST	National Institute of Standards and Technology
OHCI	Open Host Controller Interface
OTG	On-The-Go
PHY	Physical Layer
PLL	Phase-Locked Loop
PMC	Power Mode Control
PWM	Pulse Width Modulator
RIT	Repetitive Interrupt Timer
RMII	Reduced Media Independent Interface
SDRAM	Synchronous Dynamic Random Access Memory
SIMD	Single Instruction Multiple Data
SPI	Serial Peripheral Interface
SSI	Serial Synchronous Interface

Table 1052. Abbreviations ...continued

Acronym	Description
SSP	Synchronous Serial Port
TCP/IP	Transmission Control Protocol/Internet Protocol
TTL	Transistor-Transistor Logic
UART	Universal Asynchronous Receiver/Transmitter
ULPI	UTMI+ Low Pin Interface
USART	Universal Synchronous Asynchronous Receiver/Transmitter
USB	Universal Serial Bus
UTMI	USB2.0 Transceiver Macrocell Interface

49.2 References

- [1] LPC1850/30/20/10 (flashless parts) Errata sheet:
http://www.nxp.com/documents/errata_sheet/ES_LPC18X0.pdf
- [2] LPC185x/3x/2x/1x (parts with on-chip flash) Errata sheet:
http://www.nxp.com/documents/errata_sheet/ES_LPC185X_3X_2X_1X_FLASH.pdf
- [3] LPC1850/30/20/10 (flashless parts) data sheet:
http://www.nxp.com/documents/data_sheet/LPC1850_30_20_10.pdf
- [4] LPC185x/3x/2x/1x (parts with on-chip flash) data sheet:
http://www.nxp.com/documents/data_sheet/LPC185X_3X_2X_1X.pdf

49.3 Legal information

49.3.1 Definitions

Draft — The document is a draft version only. The content is still under internal review and subject to formal approval, which may result in modifications or additions. NXP Semiconductors does not give any representations or warranties as to the accuracy or completeness of information included herein and shall have no liability for the consequences of use of such information.

49.3.2 Disclaimers

Limited warranty and liability — Information in this document is believed to be accurate and reliable. However, NXP Semiconductors does not give any representations or warranties, expressed or implied, as to the accuracy or completeness of such information and shall have no liability for the consequences of use of such information. NXP Semiconductors takes no responsibility for the content in this document if provided by an information source outside of NXP Semiconductors.

In no event shall NXP Semiconductors be liable for any indirect, incidental, punitive, special or consequential damages (including - without limitation - lost profits, lost savings, business interruption, costs related to the removal or replacement of any products or rework charges) whether or not such damages are based on tort (including negligence), warranty, breach of contract or any other legal theory.

Notwithstanding any damages that customer might incur for any reason whatsoever, NXP Semiconductors' aggregate and cumulative liability towards customer for the products described herein shall be limited in accordance with the *Terms and conditions of commercial sale* of NXP Semiconductors.

Right to make changes — NXP Semiconductors reserves the right to make changes to information published in this document, including without limitation specifications and product descriptions, at any time and without notice. This document supersedes and replaces all information supplied prior to the publication hereof.

Suitability for use — NXP Semiconductors products are not designed, authorized or warranted to be suitable for use in life support, life-critical or safety-critical systems or equipment, nor in applications where failure or

malfunction of an NXP Semiconductors product can reasonably be expected to result in personal injury, death or severe property or environmental damage. NXP Semiconductors and its suppliers accept no liability for inclusion and/or use of NXP Semiconductors products in such equipment or applications and therefore such inclusion and/or use is at the customer's own risk.

Applications — Applications that are described herein for any of these products are for illustrative purposes only. NXP Semiconductors makes no representation or warranty that such applications will be suitable for the specified use without further testing or modification.

Customers are responsible for the design and operation of their applications and products using NXP Semiconductors products, and NXP Semiconductors accepts no liability for any assistance with applications or customer product design. It is customer's sole responsibility to determine whether the NXP Semiconductors product is suitable and fit for the customer's applications and products planned, as well as for the planned application and use of customer's third party customer(s). Customers should provide appropriate design and operating safeguards to minimize the risks associated with their applications and products.

NXP Semiconductors does not accept any liability related to any default, damage, costs or problem which is based on any weakness or default in the customer's applications or products, or the application or use by customer's third party customer(s). Customer is responsible for doing all necessary testing for the customer's applications and products using NXP Semiconductors products in order to avoid a default of the applications and the products or of the application or use by customer's third party customer(s). NXP does not accept any liability in this respect.

Export control — This document as well as the item(s) described herein may be subject to export control regulations. Export might require a prior authorization from competent authorities.

49.3.3 Trademarks

Notice: All referenced brands, product names, service names and trademarks are the property of their respective owners.

I²C-bus — logo is a trademark of NXP B.V.

49.4 Tables

Table 1.	Ordering information	15	Table 44.	IAP Command Summary	77
Table 2.	Ordering options (flashless parts)	15	Table 45.	IAP Initialization command	77
Table 3.	Ordering information (parts with on-chip flash)	16	Table 46.	IAP Prepare sectors for write operation command	78
Table 4.	Ordering options (parts with on-chip flash)	17	Table 47.	IAP Copy RAM to Flash command	79
Table 5.	LPC18xx SRAM configuration	22	Table 48.	IAP Erase Sectors command	79
Table 6.	LPC185x/3x/2x/1x Flash configuration	23	Table 49.	IAP Blank check sectors command	80
Table 7.	OTP bank programming API functions available in ROM	32	Table 50.	IAP Read part identification number command	80
Table 8.	OTP content for secure and non-secure parts	33	Table 51.	IAP Read Boot Code version number command	80
Table 9.	OTP memory description (OTP base address 0x4004 5000)	34	Table 52.	IAP Read device serial number command	81
Table 10.	OTP memory bank 3, word 0 - Customer control data (address offset 0x030)	35	Table 53.	IAP Compare command	81
Table 11.	OTP memory bank 3, word 1 - General purpose OTP memory 2, word 0, or USB ID (address offset 0x034)	35	Table 54.	IAP Re-invoke ISP	82
Table 12.	OTP memory bank 3, word 2 - General purpose OTP memory 2, word 1 (address offset 0x038)	35	Table 55.	IAP Erase page	82
Table 13.	OTP memory bank 3, word 3 - General purpose OTP memory 2, word 2 (address offset 0x03C)	35	Table 56.	IAP Set active boot flash bank	83
Table 14.	OTP function allocation	37	Table 57.	ISP Return Codes Summary	83
Table 15.	Boot mode when OTP BOOT_SRC bits are programmed	40	Table 58.	Register overview: FMC controller for flash bank A/B (base address 0x4000 C000 (flash bank A) and 0x4000 D000 (flash bank B))	84
Table 16.	Boot mode when OTP BOOT_SRC bits are zero	41	Table 59.	Flash Module Signature Start register (FMSSTART, address 0x4000 C020 (flash A) and 0x4000 D020 (flash B)) bit description	85
Table 17.	Boot image header use	46	Table 60.	Flash Module Signature Stop register (FMSSTOP, address 0x4000 C024 (flash A) and 0x4000 D024 (flash B)) bit description	85
Table 18.	Boot image header description	47	Table 61.	FMSW0 register bit description (FMSW0, address 0x4000 C02C (flash A) and 0x4000 D02C (flash B))	85
Table 19.	QSPI devices supported by the boot code and the SPIFI API	53	Table 62.	FMSW1 register bit description (FMSW1, address: 0x4000 C030 (flash A) and 0x4000 D030 (flash B))	86
Table 20.	Typical boot process timing parameters	54	Table 63.	FMSW2 register bit description (FMSW2, address 0x4000 C034 (flash A) and 0x4000 D034 (flash B))	86
Table 21.	ISP clocking and power control	56	Table 64.	FMSW3 register bit description (FMSW3, address 0x4000 C038 (flash A) and 0x4000 D038 (flash B))	86
Table 22.	ISP functionality for flash parts	57	Table 65.	Flash module Status register (FMSTAT, address 0x4000 CFE0 (flash A) and 0x4000 DFE0 (flash B)) bit description	86
Table 23.	ISP functionality for flash-less parts	57	Table 66.	Flash Module Status Clear register (FMSTATCLR, address 0x4000 CFE8 (flash A) and 0x4000 DFE8 (flash B)) bit description	86
Table 24.	Flash configuration	62	Table 67.	AES API calls	91
Table 25.	Code Read Protection options	63	Table 68.	Boot image header description	101
Table 26.	Code Read Protection hardware/software interaction	64	Table 69.	Typical boot process timing parameters	103
Table 27.	ISP command summary	65	Table 70.	NVIC pin description	105
Table 28.	ISP Unlock command	65	Table 71.	Connection of interrupt sources to the NVIC	106
Table 29.	ISP Set Baud Rate command	66	Table 72.	Register overview: NVIC (base address 0xE000 E000)	107
Table 30.	ISP Echo command	66	Table 73.	Event router clocking and power control	109
Table 31.	ISP Write to RAM command	67	Table 74.	Event router inputs	110
Table 32.	ISP Read Memory command	67	Table 75.	Event router pin description	112
Table 33.	ISP Prepare sectors for write operation command	68	Table 76.	Register overview: Event router (base address 0x4004 4000)	112
Table 34.	ISP Copy command	69	Table 77.	Level configuration register (HILO - address	
Table 35.	ISP Go command	70			
Table 36.	ISP Erase sector command	70			
Table 37.	ISP Blank check sector command	71			
Table 38.	ISP Read Part Identification command	71			
Table 39.	LPC18xx part identification numbers	71			
Table 40.	ISP Read Boot Code version number command	73			
Table 41.	ISP Read device serial number command	73			
Table 42.	ISP Compare command	73			
Table 43.	ISP Set active boot flash bank command	74			

0x4004 4000) bit description	112	selectable inputs	151
Table 78. EDGE and HILO combined register settings	116	Table 108. Clock sources for output stages	151
Table 79. Edge configuration register (EDGE - address 0x4004 4004) bit description	116	Table 109. CGU pin description	153
Table 80. Clear event enable register (CLR_EN - address 0x4004 4FD8) bit description	119	Table 110. Register overview: CGU (base address 0x4005 0000)	153
Table 81. Event set enable register (SET_EN - address 0x4004 4FDC) bit description	120	Table 111. FREQ_MON register (FREQ_MON, address 0x4005 0014) bit description	156
Table 82. Event status register (STATUS - address 0x4004 4FE0) bit description	121	Table 112. XTAL_OSC_CTRL register (XTAL_OSC_CTRL, address 0x4005 0018) bit description	157
Table 83. Event enable register (ENABLE - address 0x4004 4FE4) bit description	122	Table 113. PLL0USB status register (PLL0USB_STAT, address 0x4005 001C) bit description	158
Table 84. Clear event status register (CLR_STAT - address 0x4004 4FE8) bit description	124	Table 114. PLL0USB control register (PLL0USB_CTRL, address 0x4005 0020) bit description	158
Table 85. Set event status register (SET_STAT - address 0x4004 4FEC) bit description	125	Table 115. PLL0USB M-divider register (PLL0USB_MDIV, address 0x4005 0024) bit description	160
Table 86. CREG clocking and power control	127	Table 116. PLL0USB NP-divider register (PLL0USB_NP_DIV, address 0x4005 0028) bit description	161
Table 87. Register overview: Configuration registers (base address 0x4004 3000)	129	Table 117. PLL0AUDIO status register (PLL0AUDIO_STAT, address 0x4005 002C) bit description	162
Table 88. CREG0 register (CREG0, address 0x4004 3004) bit description	130	Table 118. PLL0AUDIO control register (PLL0AUDIO_CTRL, address 0x4005 0030) bit description	162
Table 89. CREG1 register (CREG1, address 0x4004 3008) bit description	131	Table 119. PLL0AUDIO M-divider register (PLL0AUDIO_MDIV, address 0x4005 0034) bit description	164
Table 90. Memory mapping register (M3MEMMAP, address 0x4004 3100) bit description	132	Table 120. PLL0 AUDIO NP-divider register (PLL0AUDIO_NP_DIV, address 0x4005 0038) bit description	165
Table 91. CREG5 control register (CREG5, address 0x4004 3118) bit description	132	Table 121. PLL0AUDIO fractional divider register (PLL0AUDIO_FRAC, address 0x4005 003C) bit description	165
Table 92. DMA mux control register (DMAMUX, address 0x4004 311C) bit description	132	Table 122. PLL1 status register (PLL1_STAT, address 0x4005 0040) bit description	165
Table 93. Flash Accelerator Configuration for flash bank A register (FLASHCFGA - address 0x4004 3120) bit description	136	Table 123. PLL1_CTRL register (PLL1_CTRL, address 0x4005 0044) bit description	166
Table 94. Flash Accelerator Configuration for flash bank B register (FLASHCFGB - address 0x4004 3124) bit description	137	Table 124. IDIVA control register (IDIVA_CTRL, address 0x4005 0048) bit description	167
Table 95. ETB SRAM configuration register (ETBCFG, address 0x4004 3128) bit description	137	Table 125. IDIVB/C/D control registers (IDIVB_CTRL, address 0x4005 004C; IDIVC_CTRL, address 0x4005 0050; IDIVD_CTRL, address 0x4005 0054) bit description	168
Table 96. CREG6 control register (CREG6, address 0x4004 312C) bit description	138	Table 126. IDIVE control register (IDIVE_CTRL, address 0x4005 0058) bit description	169
Table 97. Chip ID register (CHIPID, address 0x4004 3200) bit description	139	Table 127. BASE_SAFE_CLK control register (BASE_SAFE_CLK, address 0x4005 005C) bit description	170
Table 98. USB0 frame length adjust register (USB0FLADJ, address 0x4004 3500) bit description	140	Table 128. BASE_USB0_CLK control register	
Table 99. USB1 frame length adjust register (USB1FLADJ, address 0x4004 3600) bit description	141		
Table 100. Memory retention	144		
Table 101. Register overview: Power Mode Controller (PMC) (base address 0x4004 2000)	144		
Table 102. Hardware sleep event enable register (PD0_SLEEPS0_HW_ENA - address 0x4004 2000) bit description	145		
Table 103. Power-down modes register (PD0_SLEEPS0_MODE - address 0x4004 201C) bit description	145		
Table 104. Typical settings for PMC power modes	145		
Table 105. CGU clocking and power control	146		
Table 106. CGU base clocks	150		
Table 107. Clock sources for clock generators with			

	(BASE_USB0_CLK, address 0x4005 0060) bit description	171		0x4005 110C,..., 0x4005 1A04) bit description	201
Table 129.	BASE_USB1_CLK control register (BASE_USB1_CLK, address 0x4005 0068) bit description	171	Table 151.	CCU2 branch clock status register (CLK_XXX_STAT, addresses 0x4005 2104, 0x4005 2204,..., 0x4005 2804) bit description	201
Table 130.	BASE_M3_CLK to BASE_UART3_CLK control registers (BASE_M3_CLK to BASE_UART3_CLK, address 0x4005 006C to 0x4005 00A8) bit description	172	Table 152.	RGU clocking and power control.	203
Table 131.	BASE_OUT_CLK control register (BASE_OUT_CLK, addresses 0x4005 00AC) bit description	173	Table 153.	Reset output configuration	204
Table 132.	BASE_AUDIO_CLK control register (BASE_AUDIO_CLK, addresses 0x4005 00C0) bit description	174	Table 154.	Reset priority	206
Table 133.	BASE_CGU_OUT0_CLK to BASE_CGU_OUT1_CLK control register (BASE_CGU_OUT0_CLK to BASE_CGU_OUT1_CLK, addresses 0x4005 00C4 to 0x4005 00C8) bit description	175	Table 155.	Register overview: RGU (base address: 0x4005 3000)	207
Table 134.	PLL0 operating modes	178	Table 156.	Reset control register 0 (RESET_CTRL0, address 0x4005 3100) bit description	210
Table 135.	DIRECTL and DIRECTO bit settings in HP0/1_Mode register	179	Table 157.	Reset control register 1 (RESET_CTRL1, address 0x4005 3104) bit description	211
Table 136.	PLL0 (for USB) settings for 480 MHz output clock	186	Table 158.	Reset status register 0 (RESET_STATUS0, address 0x4005 3110) bit description	213
Table 137.	PLL0AUDIO divider settings for 12 MHz input.	186	Table 159.	Reset status register 1 (RESET_STATUS1, address 0x4005 3114) bit description	214
Table 138.	PLL0AUDIO divider setting for 12 MHz with fractional divider bypassed.	188	Table 160.	Reset status register 2 (RESET_STATUS2, address 0x4005 3118) bit description	216
Table 139.	CCU clocking and power control	190	Table 161.	Reset status register 3 (RESET_STATUS3, address 0x4005 311C) bit description	218
Table 140.	CCU1 branch clocks	191	Table 162.	Reset active status register 0 (RESET_ACTIVE_STATUS0, address 0x4005 3150) bit description	219
Table 141.	CCU2 branch clocks	192	Table 163.	Reset active status register 1 (RESET_ACTIVE_STATUS1, address 0x4005 3154) bit description	221
Table 142.	Register overview: CCU1 (base address 0x4005 1000)	193	Table 164.	Reset external status register 1 (RESET_EXT_STAT1, address 0x4005 3404) bit description	223
Table 143.	Register overview: CCU2 (base address 0x4005 2000)	196	Table 165.	Reset external status register 2 (RESET_EXT_STAT2, address 0x4005 3408) bit description	224
Table 144.	CCU1/2 power mode register (CCU1_PM, address 0x4005 1000 and CCU2_PM, address 0x4005 2000) bit description	197	Table 166.	Reset external status register 5 (RESET_EXT_STAT5, address 0x4005 3414) bit description	224
Table 145.	CCU1 base clock status register (CCU1_BASE_STAT, address 0x4005 1004) bit description	197	Table 167.	Reset external status registers x (RESET_EXT_STATx, address 0x4005 34xx) bit description	224
Table 146.	CCU2 base clock status register (CCU2_BASE_STAT, address 0x4005 2004) bit description	198	Table 168.	Reset external status registers y (RESET_EXT_STATy, address 0x4005 34yy) bit description	225
Table 147.	CCU1 branch clock configuration register (CLK_XXX_CFG, addresses 0x4005 1100, 0x4005 1104,..., 0x4005 1A00) bit description	199	Table 169.	LPC1850/30/20/10 Pin description (flashless parts)	227
Table 148.	CCU1 branch clock configuration register (CLK_M3_EMCDIV_CFG, addresses 0x4005 1478) bit description	199	Table 170.	LPC18xx Pin description (flash-based parts)	279
Table 149.	CCU2 branch clock configuration register (CLK_XXX_CFG, addresses 0x4005 2100, 0x4005 2200,..., 0x4005 2800) bit description	200	Table 171.	SCU clocking and power control.	331
Table 150.	CCU1 branch clock status register (CLK_XXX_STAT, addresses 0x4005 1104,		Table 172.	Pin multiplexing.	335
			Table 173.	Register overview: System Control Unit (SCU) (base address 0x4008 6000)	343
			Table 174.	Pin configuration registers for normal-drive pins (SFS, address 0x4008 6000 (SPSP0_0) to	

0x4008 67AC (SFSPF_11)) bit description . . .351	Table 200. Timer 1 CAP1_3 capture input multiplexer (CAP1_3_IN, address 0x400C 701C) bit description 374
Table 175. Pin configuration registers for high-drive pins (SFS, address 0x4008 60C4 (SFSP1_17) to 0x4008 650C (SFSPA_3) bit description352	Table 201. Timer 2 CAP2_0 capture input multiplexer (CAP2_0_IN, address 0x400C 7020) bit description 375
Table 176. Pin configuration registers for high-speed pins (SFS, address 0x4008 618C (SPSP3_3); 0x4008 6C00 (SFSCCLK0) to 0x4008 6C0C (SFSCCLK3)) bit description353	Table 202. Timer 2 CAP2_1 capture input multiplexer (CAP2_1_IN, address 0x400C 7024) bit description 375
Table 177. Pin configuration for pins USB1_DP/USB1_DM register (SFSUSB, address 0x4008 6C80) bit description354	Table 203. Timer 2 CAP2_2 capture input multiplexer (CAP2_2_IN, address 0x400C 7028) bit description 376
Table 178. Pin configuration for open-drain I ² C-bus pins register (SFSI2C0, address 0x4008 6C84) bit description354	Table 204. Timer 2 CAP2_3 capture input multiplexer (CAP2_3_IN, address 0x400C 702C) bit description 376
Table 179. Pins controlled by the ENAIO0 register356	Table 205. Timer 3 CAP3_0 capture input multiplexer (CAP3_0_IN, address 0x400C 7030) bit description 377
Table 180. ADC0 function select register (ENAIO0, address 0x4008 6C88) bit description356	Table 206. Timer 3 CAP3_1 capture input multiplexer (CAP3_1_IN, address 0x400C 7034) bit description 378
Table 181. Pins controlled by the ENAIO1 register357	Table 207. Timer 3 CAP3_2 capture input multiplexer (CAP3_2_IN, address 0x400C 7038) bit description 378
Table 182. ADC1 function select register (ENAIO1, address 0x4008 6C8C) bit description358	Table 208. Timer 3 CAP3_3 capture input multiplexer (CAP3_3_IN, address 0x400C 703C) bit description 379
Table 183. Pins controlled by the ENAIO2 register358	Table 209. SCT CTIN_0 capture input multiplexer (CTIN_0_IN, address 0x400C 7040) bit description 379
Table 184. Analog function select register (ENAIO2, address 0x4008 6C90) bit description359	Table 210. SCT CTIN_1 capture input multiplexer (CTIN_1_IN, address 0x400C 7044) bit description 380
Table 185. EMC clock delay register (EMCDELAYCLK, address 0x4008 6D00) bit description360	Table 211. SCT CTIN_2 capture input multiplexer (CTIN_2_IN, address 0x400C 7048) bit description 381
Table 186. SD/MMC delay register (SDDELAY, address 0x4008 6D80) bit description360	Table 212. SCT CTIN_3 capture input multiplexer (CTIN_3_IN, address 0x400C 704C) bit description 381
Table 187. Pin interrupt select register 0 (PINTSEL0, address 0x4008 6E00) bit description361	Table 213. SCT CTIN_4 capture input multiplexer (CTIN_4_IN, address 0x400C 7050) bit description 382
Table 188. Pin interrupt select register 1 (PINTSEL1, address 0x4008 6E04) bit description362	Table 214. SCT CTIN_5 capture input multiplexer (CTIN_5_IN, address 0x400C 7054) bit description 382
Table 189. GIMA clocking and power control364	Table 215. SCT CTIN_6 capture input multiplexer (CTIN_6_IN, address 0x400C 7058) bit description 383
Table 190. GIMA outputs366	Table 216. SCT CTIN_7 capture input multiplexer (CTIN_7_IN, address 0x400C 705C) bit description 384
Table 191. Configuration options for the GIMA clock synchronization stages368	Table 217. Event router input 13 multiplexer (EVENTROUTER_13_IN, address 0x400C 7064) bit description 384
Table 192. Register overview: GIMA (base address: 0x400C 7000)368	Table 218. Event router input 14 multiplexer (EVENTROUTER_14_IN, address 0x400C 7068) bit description 385
Table 193. Timer 0 CAP0_0 capture input multiplexer (CAP0_0_IN, address 0x400C 7000) bit description370	Table 219. Event router input 16 multiplexer
Table 194. Timer 0 CAP0_1 capture input multiplexer (CAP0_1_IN, address 0x400C 7004) bit description370	
Table 195. Timer 0 CAP0_2 capture input multiplexer (CAP0_2_IN, address 0x400C 7008) bit description371	
Table 196. Timer 0 CAP0_3 capture input multiplexer (CAP0_3_IN, address 0x400C 700C) bit description372	
Table 197. Timer 1 CAP1_0 capture input multiplexer (CAP1_0_IN, address 0x400C 7010) bit description372	
Table 198. Timer 1 CAP1_1 capture input multiplexer (CAP1_1_IN, address 0x400C 7014) bit description373	
Table 199. Timer 1 CAP1_2 capture input multiplexer (CAP1_2_IN, address 0x400C 7018) bit description373	

(EVENTROUTER_16_IN, address 0x400C 706C) bit description	385	0x400F 4000 (B0) to 0x400F 40FF (B255)) bit description	400
Table 220. ADC start0 input multiplexer (ADCSTART0_IN, address 0x400C 7070) bit description	386	Table 242. GPIO port word pin registers (W, addresses 0x400F 5000 (W0) to 0x400F 13FC (W255)) bit description	400
Table 221. ADC start1 input multiplexer (ADCSTART1_IN, address 0x400C 7074) bit description	386	Table 243. GPIO port direction register (DIR, addresses 0x400F 6000 (DIR0) to 0x400F 601C (DIR7)) bit description	401
Table 222. GPIO pins for different pin packages	388	Table 244. GPIO port mask register (MASK, addresses 0x400F 6080 (MASK0) to 0x400F 609C (MASK7)) bit description	401
Table 223. GPIO clocking and power control	388	Table 245. GPIO port pin register (PIN, addresses 0x400F 6100 (PIN0) to 0x400F 611C (PIN7)) bit description	401
Table 224. Register overview: GPIO pin interrupts (base address: 0x4008 7000)	390	Table 246. GPIO masked port pin register (MPIN, addresses 0x400F 6180 (MPIN0) to 0x400F 619C (MPIN7)) bit description	402
Table 225. Register overview: GPIO GROUP0 interrupt (base address 0x4008 8000)	391	Table 247. GPIO port set register (SET, addresses 0x400F 6200 (SET0) to 0x400F 621C (SET7)) bit description	402
Table 226. Register overview: GPIO GROUP1 interrupt (base address 0x4008 9000)	391	Table 248. GPIO port clear register (CLR, addresses 0x400F 6280 (CLR0) to 0x400F 629C (CLR7)) bit description	402
Table 227. Register overview: GPIO port (base address 0x400F 4000)	392	Table 249. GPIO port toggle register (NOT, addresses 0x400F 6300 (NOT0) to 0x400F 632C (NOT7)) bit description	403
Table 228. Pin interrupt mode register (ISEL, address 0x4008 7000) bit description	394	Table 250. Pin interrupt registers for edge- and level-sensitive pins	405
Table 229. Pin interrupt level (rising edge) interrupt enable register (IENR, address 0x4008 7004) bit description	395	Table 251. GPDMA clocking and power control	406
Table 230. Pin interrupt level (rising edge) interrupt set register (SIENR, address 0x4008 7008) bit description	395	Table 252. Peripheral connections to the DMA controller and matching flow control signals	408
Table 231. Pin interrupt level (rising edge interrupt) clear register (CIENR, address 0x4008 700C) bit description	395	Table 253. Register overview: GPDMA (base address 0x4000 2000)	410
Table 232. Pin interrupt active level (falling edge) interrupt enable register (IENF, address 0x4008 7010) bit description	396	Table 254. DMA Interrupt Status register (INTSTAT, address 0x4000 2000) bit description	412
Table 233. Pin interrupt active level (falling edge interrupt) set register (SIENF, address 0x4008 7014) bit description	396	Table 255. DMA Interrupt Terminal Count Request Status Register (INTTCSTAT, address 0x4000 2004) bit description	412
Table 234. Pin interrupt active level (falling edge) interrupt clear register (CIENF, address 0x4008 7018) bit description	397	Table 256. DMA Interrupt Terminal Count Request Clear Register (INTTCLEAR, address 0x4000 2008) bit description	413
Table 235. Pin interrupt rising edge register (RISE, address 0x4008 701C) bit description	397	Table 257. DMA Interrupt Error Status Register (INTERRSTAT, address 0x4000 200C) bit description	413
Table 236. Pin interrupt falling edge register (FALL, address 0x4008 7020) bit description	398	Table 258. DMA Interrupt Error Clear Register (INTERRCLR, address 0x4000 2010) bit description	414
Table 237. Pin interrupt status register (IST address 0x4008 7024) bit description	398	Table 259. DMA Raw Interrupt Terminal Count Status Register (RAWINTTCSTAT, address 0x4000 2014) bit description	414
Table 238. GPIO grouped interrupt control register (CTRL, addresses 0x4008 8000 (GROUP0 INT) and 0x4008 9000 (GROUP1 INT)) bit description	398	Table 260. DMA Raw Error Interrupt Status Register (RAWINTERRSTAT, address 0x4000 2018) bit description	414
Table 239. GPIO grouped interrupt port polarity registers (PORT_POL, addresses 0x4008 8020 (PORT_POL0) to 0x4008 803C (PORT_POL7) (GROUP0 INT) and 0x4008 9020 (PORT_POL0) to 0x4008 903C (PORT_POL7) (GROUP1 INT)) bit description	399	Table 261. DMA Enabled Channel Register (ENBLDCHNS, address 0x4000 201C) bit description	415
Table 240. GPIO grouped interrupt port n enable registers (PORT_ENA, addresses 0x4008 8040 (PORT_ENA0) to 0x4008 805C (PORT_ENA7) (GROUP0 INT) and 0x4008 9040 (PORT_ENA0) to 0x4008 905C (PORT_ENA7) (GROUP1 INT)) bit description	399	Table 262. DMA Software Burst Request Register (SOFTBREQ, address 0x4000 2020) bit description	415
Table 241. GPIO port byte pin registers (B, addresses			

Table 263. DMA Software Single Request Register (SOFTSREQ, address 0x4000 2024) bit description	416	Table 290. Command Register (CMD, address 0x4000 402C) bit description	448
Table 264. DMA Software Last Burst Request Register (SOFTLBREQ, address 0x4000 2028) bit description	416	Table 291. Response Register 0 (RESP0, address 0x4000 4030) bit description	450
Table 265. DMA Software Last Single Request Register (SOFTLSREQ, address 0x4000 202C) bit description	417	Table 292. Response Register 1 (RESP1, address 0x4000 4034) bit description.	451
Table 266. DMA Configuration Register (CONFIG, address 0x4000 2030) bit description	417	Table 293. Response Register 2 (RESP2, address 0x4000 4038) bit description.	451
Table 267. DMA Synchronization Register (SYNC, address 0x4000 2034) bit description	418	Table 294. Response Register 3 (RESP3, address 0x4000 403C) bit description	451
Table 268. DMA Channel Source Address Registers (SRCADDR[0:7], 0x4000 2100 (SRCADDR0) to 0x4000 21E0 (SRCADDR7)) bit description .418		Table 295. Masked Interrupt Status Register (MINTSTS, address 0x4000 4040) bit description	451
Table 269. DMA Channel Destination Address registers (DESTADDR[0:7], 0x4000 2104 (DESTADDR0) to 0x4000 21E4 (DESTADDR7)) bit description	419	Table 296. Raw Interrupt Status Register (RINTSTS, address 0x4000 4044) bit description	452
Table 270. DMA Channel Linked List Item registers (LLI[0:7], 0x4000 2108 (LLI0) to 0x4000 21E8 (LLI7)) bit description	419	Table 297. Status Register (STATUS, address 0x4000 4048) bit description	454
Table 271. DMA Channel Control registers (CONTROL[0:7], 0x4000 210C (CONTROL0) to 0x4000 21EC (CONTROL7)) bit description	420	Table 298. FIFO Threshold Watermark Register (FIFOTH, address 0x4000 404C) bit description	455
Table 272. DMA Channel Configuration registers (CONFIG[0:7], 0x4000 2110 (CONFIG0) to 0x4000 21F0 (CONFIG7)) bit description . . .422		Table 299. Card Detect Register (CDETECT, address 0x4000 4050) bit description	456
Table 273. Flow control and transfer type bits	425	Table 300. Write Protect Register (WRTPRT, address 0x4000 4054) bit description	456
Table 274. Endian behavior	427	Table 301. Transferred CIU Card Byte Count Register (TCBCNT, address 0x4000 405C) bit description .457	
Table 275. DMA request signal usage	431	Table 302. Transferred Host to BIU-FIFO Byte Count Register (TBBCNT, address 0x4000 4060) bit description	457
Table 276. SDIO clocking and power control.	438	Table 303. Debounce Count Register (DEBNCE, address 0x4000 4064) bit description	457
Table 277. SD/MMC pin description	440	Table 304. Hardware Reset (RST_N, address 0x4000 4078) bit description	457
Table 278. Register overview: SDMMC (base address: 0x4000 4000)	440	Table 305. Bus Mode Register (BMOD, address 0x4000 4080) bit description.	458
Table 279. Control Register (CTRL, address 0x4000 4000) bit description	441	Table 306. Poll Demand Register (PLDMND, address 0x4000 4084) bit description	458
Table 280. Power Enable Register (PWREN, address 0x4000 4004) bit description	444	Table 307. Descriptor List Base Address Register (DBADDR, address 0x4000 4088) bit description .459	
Table 281. Clock Divider Register (CLKDIV, address 0x4000 4008) bit description	444	Table 308. Internal DMAC Status Register (IDSTS, address 0x4000 408C) bit description	459
Table 282. SD Clock Source Register (CLKSRC, address 0x4000 400C) bit description	445	Table 309. Internal DMAC Interrupt Enable Register (IDINTEN, address 0x4000 4090) bit description .460	
Table 283. Clock Enable Register (CLKENA, address 0x4000 4010) bit description	445	Table 310. Current Host Descriptor Address Register (DSCADDR, address 0x4000 4094) bit description	461
Table 284. Time-out Register (TMOUT, address 0x4000 4014) bit description	445	Table 311. Current Buffer Descriptor Address Register (BUFADDR, address 0x4000 4098) bit description .461	
Table 285. Card Type Register (CTYPE, address 0x4000 4018) bit description	446	Table 312. SEND_AUTO_STOP bit	462
Table 286. Block Size Register (BLKSIZ, address 0x4000 401C) bit description.	446	Table 313. CMD register settings for No-Data Command468	
Table 287. Byte Count Register (BYTCNT, address 0x4000 4020) bit description	446	Table 314. CMD register settings for Single-block or Multiple-block Read	470
Table 288. Interrupt Mask Register (INTMASK, address 0x4000 4024) bit description	446	Table 315. CMD register settings for Single-block or Multiple-block write	471
Table 289. Command Argument Register (CMDARG, address 0x4000 4028) bit description.	447	Table 316. Parameters for CMDARG register	473
		Table 317. Parameters for CMDARG register	475

Table 318. Parameters for CMDARG register	476	Period register (DYNAMICRAS - address 0x4000 5034) bit description	514
Table 319. CMD register settings	477	Table 356. Dynamic Memory Self Refresh Exit Time register (DYNAMICSREX - address 0x4000 5038) bit description	515
Table 320. BLKSIZ register	477	Table 357. Dynamic Memory Last Data Out to Active Time register (DYNAMICAPR - address 0x4000 503C) bit description	515
Table 321. BYTCNT register	477	Table 358. Dynamic Memory Data In to Active Command Time register (DYNAMICDAL - address 0x4000 5040) bit description	516
Table 322. Parameters for CMDARG register	478	Table 359. Dynamic Memory Write Recovery Time register (DYNAMICWR - address 0x4000 5044) bit description	516
Table 323. CMD register settings	478	Table 360. Dynamic Memory Active to Active Command Period register (DYNAMICRCR - address 0x4000 5048) bit description	516
Table 324. BLKSIZ register	479	Table 361. Dynamic Memory Auto Refresh Period register (DYNAMICRFC - address 0x4000 504C) bit description	517
Table 325. BYTCNT register	479	Table 362. Dynamic Memory Exit Self Refresh register (DYNAMICXSR - address 0x4000 5050) bit description	517
Table 326. SD/MMC DMA DESC0 descriptor	484	Table 363. Dynamic Memory Active Bank A to Active Bank B Time register (DYNAMICRRD - address 0x4000 5054) bit description	518
Table 327. SD/MMC DMA DESC1 descriptor	485	Table 364. Dynamic Memory Load Mode register to Active Command Time (DYNAMICMRD - address 0x4000 5058) bit description	518
Table 328. SD/MMC DMA DESC2 descriptor	485	Table 365. Static Memory Extended Wait register (STATICEXTENDEDWAIT - address 0x4000 5080) bit description	518
Table 329. SD/MMC DMA DESC3 descriptor	486	Table 366. Dynamic Memory Configuration registers (DYNAMICCONFIG[0:3], address 0x4000 5100 (DYNAMICCONFIG0), 0x4000 5120 (DYNAMICCONFIG1), 0x4000 5140 (DYNAMICCONFIG2), 0x4000 5160 (DYNAMICCONFIG3)) bit description	519
Table 330. PBL and watermark levels	489	Table 367. Address mapping	520
Table 331. SPIFI clocking and power control	490	Table 368. Dynamic Memory RASCAS Delay registers (DYNAMICRASCAS[0:3], address 0x4000 5104 (DYNAMICRASCAS0), 0x4000 5124 (DYNAMICRASCAS1), 0x4000 5144 (DYNAMICRASCAS2), 0x4000 5164 (DYNAMICRASCAS3)) bit description	522
Table 332. SPIFI flash memory map	491	Table 369. Static Memory Configuration registers (STATICCONFIG[0:3], address 0x4000 5200 (STATICCONFIG0), 0x4000 5220 (STATICCONFIG1), 0x4000 5240 (STATICCONFIG2), 0x4000 5260 (STATICCONFIG3)) bit description	522
Table 333. SPIFI pin description	491	Table 370. Static Memory Write Enable Delay registers (STATICWAITWEN[0:3], address 0x4000 5204 (STATICWAITWEN0), 0x4000 5224 (STATICWAITWEN1), 0x4000 5244 (STATICWAITWEN2), 0x4000 5264 (STATICWAITWEN3)) bit description	524
Table 334. Register overview: SPIFI (base address 0x4000 3000)	492	Table 371. Static Memory Output Enable delay registers	
Table 335. SPIFI control register (CTRL, address 0x4000 3000) bit description	492		
Table 336. SPIFI command register (CMD, address 0x4000 3004) bit description	494		
Table 337. SPIFI address register (ADDR, address 0x4000 3008) bit description	495		
Table 338. SPIFI intermediate data register (IDATA, address 0x4000 300C) bit description	495		
Table 339. SPIFI cache limit register (CLIMIT, address 0x4000 3010) bit description	495		
Table 340. SPIFI Data register (DATA, address 0x4000 3014) bit description	496		
Table 341. SPIFI memory command register (MCMD, address 0x4000 3018) bit description	496		
Table 342. SPIFI status register (STAT, address 0x4000 301C) bit description	497		
Table 343. EMC pinout for different packages.	502		
Table 344. EMC clocking and power control	503		
Table 345. Memory bank selection	505		
Table 346. EMC pin description	506		
Table 347. Register overview: External memory controller (base address 0x4000 5000)	506		
Table 348. EMC Control register (CONTROL - address 0x4000 5000) bit description	510		
Table 349. EMC Status register (STATUS - address 0x4000 5004) bit description	510		
Table 350. EMC Configuration register (CONFIG - address 0x4000 5008) bit description	511		
Table 351. Dynamic Control register (DYNAMICCONTROL - address 0x4000 5020) bit description	511		
Table 352. Dynamic Memory Refresh Timer register (DYNAMICREFRESH - address 0x4000 5024) bit description	513		
Table 353. Dynamic Memory Read Configuration register (DYNAMICREADCONFIG - address 0x4000 5028) bit description	514		
Table 354. Dynamic Memory Precharge Command Period register (DYNAMICCRP - address 0x4000 5030) bit description	514		
Table 355. Dynamic Memory Active to Precharge Command			

(STATICWAITOEN[0:3], address 0x4000 5208 (STATICWAITOEN0), 0x4000 5228 (STATICWAITOEN1), 0x4000 5248 (STATICWAITOEN2), 0x4000 5268 (STATICWAITOEN3)) bit description	525	- address 0x4000 6144) register bit description 550	
Table 372. Static Memory Read Delay registers (STATICWAITRD[0:3], address 0x4000 520C (STATICWAITRD0), 0x4000 522C (STATICWAITRD1), 0x4000 524C (STATICWAITRD2), 0x4000 526C (STATICWAITRD3)) bit description.	525	Table 394. USB Status register in host mode (USBSTS_H - address 0x4000 6144) register bit description	552
Table 373. Static Memory Page Mode Read Delay registers (STATICWAITPAGE[0:3], address 0x4000 5210 (STATICWAITPAGE0), 0x4000 5230 (STATICWAITPAGE1), 0x4000 5250 (STATICWAITPAGE2), 0x4000 5270 (STATICWAITPAGE3)) bit description	526	Table 395. USB Interrupt register in device mode (USBINTR_D - address 0x4000 6148) bit description	554
Table 374. Static Memory Write Delay registers (STATICWAITWR[0:3], address 0x4000 5214 (STATICWAITWR0), 0x4000 5234 (STATICWAITWR1), 0x4000 5254 (STATICWAITWR2), 0x4000 5274 (STATICWAITWR3)) bit description	526	Table 396. USB Interrupt register in host mode (USBINTR_H - address 0x4000 6148) bit description	555
Table 375. Static Memory Turn-around Delay registers (STATICWAITTURN[0:3], address 0x4000 5218 (STATICWAITTURN0), 0x4000 5238 (STATICWAITTURN1), 0x4000 5258 (STATICWAITTURN2), 0x4000 5278 (STATICWAITTURN3)) bit description	527	Table 397. USB frame index register in device mode (FRINDEX_D - address 0x4000 614C) bit description	556
Table 376. SDRAM mode register description.	530	Table 398. USB frame index register in host (FRINDEX_H - address 0x4000 614C) bit description	557
Table 377. USB0 clocking and power control	536	Table 399. Number of bits used for the frame list index	557
Table 378. USB related acronyms.	538	Table 400. USB Device Address register in device mode (DEVICEADDR - address 0x4000 6154) bit description	558
Table 379. Fixed endpoint configuration	538	Table 401. USB Periodic List Base register in host mode (PERIODICLISTBASE - address 0x4000 6154) bit description	558
Table 380. USB Packet size	539	Table 402. USB Endpoint List Address register in device mode (ENDPOINTLISTADDR - address 0x4000 6158) bit description	559
Table 381. USB0 pin description	539	Table 403. USB Asynchronous List Address register in host mode (ASYNCLISTADDR- address 0x4000 6158) bit description	559
Table 382. Register access abbreviations.	540	Table 404. USB TT Control register in host mode (TTCTRL - address 0x4000 615C) bit description	559
Table 383. Register overview: USB0 OTG controller (register base address 0x4000 6000)	541	Table 405. USB burst size register (BURSTSIZE - address 0x4000 6160) bit description - device/host mode 560	
Table 384. System bus interface configuration register (SBUSCFG - address 0x4000 6090) bit description	544	Table 406. USB Transfer buffer Fill Tuning register in host mode (TXFILLTUNING - address 0x4000 6164) bit description	561
Table 385. CAPLENGTH register (CAPLENGTH - address 0x4000 6100) bit description	544	Table 407. USB BINTERVAL register (BINTERVAL - address 0x4000 6174) bit description	561
Table 386. HCSPARAMS register (HCSPARAMS - address 0x4000 6104) bit description	544	Table 408. USB endpoint NAK register (ENDPTNAK - address 0x4000 6178) bit description	562
Table 387. HCCPARAMS register (HCCPARAMS - address 0x4000 6108) bit description	545	Table 409. USB Endpoint NAK Enable register (ENDPTNAKEN - address 0x4000 617C) bit description	563
Table 388. DCIVERSION register (DCIVERSION - address 0x4000 6120) bit description	545	Table 410. Port Status and Control register in device mode (PORTSC1_D - address 0x4000 6184) bit description	563
Table 389. DCCPARAMS (address 0x4000 6124)	546	Table 411. Port Status and Control register in host mode (PORTSC1_H - address 0x4000 6184) bit description	566
Table 390. USB Command register in device mode (USBCMD_D - address 0x4000 6140) bit description	546	Table 412. Port states as described by the PE and SUSP bits in the PORTSC1 register	570
Table 391. USB Command register in host mode (USBCMD_H - address 0x4000 6140) bit description - host mode	547	Table 413. OTG Status and Control register (OTGSC - address 0x4000 61A4) bit description	571
Table 392. Frame list size values	549	Table 414. USB Mode register in device mode (USBMODE_D - address 0x4000 61A8) bit description	573
Table 393. USB Status register in device mode (USBSTS_D - address 0x4000 6144) register bit description 550		Table 415. USB Mode register in host mode (USBMODE_H - address 0x4000 61A8) bit description	574

Table 416. USB Endpoint Setup Status register (ENDPTSETUPSTAT - address 0x4000 61AC) bit description	575	(USBCMD_H - address 0x4000 7140) bit description	629
Table 417. USB Endpoint Prime register (ENDPTPRIME - address 0x4000 61B0) bit description	576	Table 453. Frame list size values	631
Table 418. USB Endpoint Flush register (ENDPTFLUSH - address 0x4000 61B4) bit description	576	Table 454. USB Status register in device mode (USBSTS_D - address 0x4000 7144) register bit description	632
Table 419. USB Endpoint Status register (ENDPTSTAT - address 0x4000 61B8) bit description	577	Table 455. USB Status register in host mode (USBSTS_H - address 0x4000 7144) register bit description	634
Table 420. USB Endpoint Complete register (ENDPTCOMPLETE - address 0x4000 61BC) bit description	578	Table 456. USB Interrupt register in device mode (USBINTR_D - address 0x4000 7148) bit description	636
Table 421. USB Endpoint 0 Control register (ENDPTCTRL0 - address 0x4000 61C0) bit description	578	Table 457. USB Interrupt register in host mode (USBINTR_H - address 0x4000 7148) bit description	637
Table 422. USB Endpoint 1 to 5 control registers (ENDPTCTRL - address 0x4000 61C4 (ENDPTCTRL1) to 0x4000 61D4 (ENDPTCTRL5)) bit description	579	Table 458. USB frame index register in device mode (FRINDEX_D - address 0x4000 714C) bit description	638
Table 423. Handling of directly connected full-speed and low-speed devices	585	Table 459. USB frame index register in host mode (FRINDEX_H - address 0x4000 714C) bit description	639
Table 424. Split state machine properties	587	Table 460. Number of bits used for the frame list index	639
Table 425. Endpoint capabilities and characteristics	592	Table 461. USB Device Address register in device mode (DEVICEADDR - address 0x4000 7154) bit description	640
Table 426. Current dTD pointer	592	Table 462. USB Periodic List Base register in host mode (PERIODICLISTBASE - address 0x4000 7154) bit description	640
Table 427. Set-up buffer	593	Table 463. USB Endpoint List Address register in device mode (ENDPOINTLISTADDR - address 0x4000 7158) bit description	641
Table 428. Next dTD pointer	593	Table 464. USB Asynchronous List Address register in host mode (ASYNCLISTADDR - address 0x4000 7158) bit description	641
Table 429. dTD token	594	Table 465. USB TT Control register in host mode (TTCTRL - address 0x4000 715C) bit description	641
Table 430. dTD buffer page pointer list	595	Table 466. USB burst size register in device/host mode (BURSTSIZE - address 0x4000 7160) bit description	642
Table 431. Device controller endpoint initialization	600	Table 467. USB Transfer buffer Fill Tuning register in host mode (TXFILLTUNING - address 0x4000 7164) bit description	643
Table 432. Device controller stall response matrix	601	Table 468. USB ULPI viewport register (ULPIVIEWPORT - address 0x4000 7170) bit description	644
Table 433. Variable length transfer protocol example (ZLT = 0)	603	Table 469. USB BINTERVAL register (BINTERVAL - address 0x4000 7174) bit description in device/host mode	645
Table 434. Variable length transfer protocol example (ZLT = 1)	603	Table 470. USB endpoint NAK register in device mode (ENDPTNAK - address 0x4000 7178) bit description	645
Table 435. Interrupt/bulk endpoint bus response matrix	604	Table 471. USB Endpoint NAK Enable register in device mode (ENDPTNAKEN - address 0x4000 717C) bit description	646
Table 436. Control endpoint bus response matrix	607	Table 472. Port Status and Control register in device mode (PORTSC1_D - address 0x4000 7184) bit description	647
Table 437. Isochronous endpoint bus response matrix	609	Table 473. Port Status and Control register in host mode (PORTSC1_H - address 0x4000 7184) bit description	
Table 438. Device error matrix.	614		
Table 439. High-frequency interrupt events.	614		
Table 440. Low-frequency interrupt events	614		
Table 441. Error interrupt events	615		
Table 442. USB1 clocking and power control	621		
Table 443. USB1 pin description	623		
Table 444. Register access abbreviations.	624		
Table 445. Register overview: USB1 host/device controller (register base address 0x4000 7000)	624		
Table 446. CAPLENGTH register (CAPLENGTH - address 0x4000 7100) bit description	625		
Table 447. HCSPARAMS register (HCSPARAMS - address 0x4000 7104) bit description	626		
Table 448. HCCPARAMS register (HCCPARAMS - address 0x4000 7108) bit description	627		
Table 449. DCIVERSION register (DCIVERSION - address 0x4000 7120) bit description	627		
Table 450. DCCPARAMS (address 0x4000 7124)	627		
Table 451. USB Command register in device mode (USBCMD_D - address 0x4000 7140) bit description	628		
Table 452. USB Command register in host mode			

.....	649	Table 504. <code>_USB_OTHER_SPEED_CONFIGURATION</code> class structure	673
Table 474. Port states as described by the PE and SUSP bits in the PORTSC1 register	654	Table 505. <code>_USB_SETUP_PACKET</code> class structure.	673
Table 475. USB Mode register in device mode (<code>USBMODE_D</code> - address 0x4000 71A8) bit description	654	Table 506. <code>_USB_STRING_DESCRIPTOR</code> class structure . 674	
Table 476. USB Mode register in host mode (<code>USBMODE_H</code> - address 0x4000 71A8) bit description	655	Table 507. <code>_WB_T</code> class structure	674
Table 477. USB Endpoint Setup Status register (<code>ENDPTSETUPSTAT</code> - address 0x4000 71AC) bit description	656	Table 508. <code>USBD_API</code> class structure	674
Table 478. USB Endpoint Prime register (<code>ENDPTPRIME</code> - address 0x4000 71B0) bit description	657	Table 509. <code>USBD_API_INIT_PARAM</code> class structure. . .	675
Table 479. USB Endpoint Flush register (<code>ENDPTFLUSH</code> - address 0x4000 71B4) bit description	657	Table 510. <code>USBD_CDC_API</code> class structure	677
Table 480. USB Endpoint Status register (<code>ENDPTSTAT</code> - address 0x4000 71B8) bit description	658	Table 511. <code>USBD_CDC_INIT_PARAM</code> class structure . .	679
Table 481. USB Endpoint Complete register (<code>ENDPTCOMPLETE</code> - address 0x4000 71BC) bit description	659	Table 512. <code>USBD_CORE_API</code> class structure	687
Table 482. USB Endpoint 0 Control register (<code>ENDPTCTRL0</code> - address 0x4000 71C0) bit description	659	Table 513. <code>USBD_DFU_API</code> class structure.	691
Table 483. USB Endpoint 1 to 3 control registers (<code>ENDPTCTRL</code> - address 0x4000 71C4 (<code>ENDPTCTRL1</code>) to 0x4000 71CC (<code>ENDPTCTRL3</code>)) bit description	660	Table 514. <code>USBD_DFU_INIT_PARAM</code> class structure . .	691
Table 484. <code>_WORD_BYTE</code> class structure	666	Table 515. <code>USBD_HID_API</code> class structure	694
Table 485. <code>_BM_T</code> class structure	667	Table 516. <code>USBD_HID_INIT_PARAM</code> class structure. . .	695
Table 486. <code>_CDC_ABSTRACT_CONTROL_MANAGEMENT</code> <code>_DESCRIPTOR</code> class structure	667	Table 517. <code>USBD_HW_API</code> class structure	701
Table 487. <code>_CDC_CALL_MANAGEMENT_DESCRIPTOR</code> class structure	667	Table 518. <code>USBD_MSC_API</code> class structure	709
Table 488. <code>_CDC_HEADER_DESCRIPTOR</code> class structure 667		Table 519. <code>USBD_MSC_INIT_PARAM</code> class structure. .	710
Table 489. <code>_CDC_LINE_CODING</code> class structure.	668	Table 520. Ethernet clocking and power control.	714
Table 490. <code>_CDC_UNION_1SLAVE_DESCRIPTOR</code> class structure	668	Table 521. Ethernet pin description	716
Table 491. <code>_CDC_UNION_DESCRIPTOR</code> class structure . . 668		Table 522. Register overview: Ethernet MAC and DMA (base address 0x4001 0000)	717
Table 492. <code>_DFU_STATUS</code> class structure	668	Table 523. MAC Configuration register (<code>MAC_CONFIG</code> , address 0x4001 0000) bit description	718
Table 493. <code>_HID_DESCRIPTOR</code> class structure.	669	Table 524. MAC Frame filter register (<code>MAC_FRAME_FILTER</code> , address 0x4001 0004) bit description	721
Table 494. <code>_HID_DESCRIPTOR::_HID_DESCRIPTOR_LIS</code> <code>T</code> class structure	669	Table 525. MAC Hash table high register (<code>MAC_HASHTABLE_HIGH</code> , address 0x4001 0008) bit description	723
Table 495. <code>_HID_REPORT_T</code> class structure	669	Table 526. MAC Hash table low register (<code>MAC_HASHTABLE_LOW</code> , address 0x4001 0008) bit description	723
Table 496. <code>_MSC_CBW</code> class structure	670	Table 527. MAC MII Address register (<code>MAC_MII_ADDR</code> , address 0x4001 0010) bit description	724
Table 497. <code>_MSC_CSW</code> class structure	670	Table 528. CSR clock range values	724
Table 498. <code>_REQUEST_TYPE</code> class structure	670	Table 529. MII Data register (<code>MAC_MII_DATA</code> , address 0x4001 0014) bit description	725
Table 499. <code>_USB_COMMON_DESCRIPTOR</code> class structure 670		Table 530. MAC Flow control register (<code>MAC_FLOW_CTRL</code> , address 0x4001 0018) bit description	726
Table 500. <code>_USB_CORE_DESCS_T</code> class structure . .	671	Table 531. MAC VLAN tag register (<code>MAC_VLAN_TAG</code> , address 0x4001 01C) bit description	727
Table 501. <code>_USB_DEVICE_QUALIFIER_DESCRIPTOR</code> class structure	671	Table 532. MAC Debug register (<code>MAC_DEBUG</code> , address 0x4001 0024) bit description	728
Table 502. <code>_USB_DFU_FUNC_DESCRIPTOR</code> class structure	672	Table 533. MAC Remote wake-up frame filter register (<code>MAC_RWAKE_FRFLT</code> , address 0x4001 0028) bit description	729
Table 503. <code>_USB_INTERFACE_DESCRIPTOR</code> class structure	672	Table 534. MAC PMT control and status register (<code>MAC_PMT_CTRL_STAT</code> , address 0x4001 002C) bit description	729
		Table 535. MAC Interrupt status register (<code>MAC_INTR</code> , address 0x4001 0038) bit description	730
		Table 536. MAC Interrupt mask register (<code>MAC_INTR_MASK</code> , address 0x4001 003C) bit description	731
		Table 537. MAC Address 0 high register (<code>MAC_ADDR0_HIGH</code> , address 0x4001 0040) bit description	732
		Table 538. MAC Address 0 low register	

(MAC_ADDR0_LOW, address 0x4001 0044) bit description	732	Table 561. DMA Receive interrupt watchdog timer register (DMA_REC_INT_WDT, address 0x4001 1024) bit description	752
Table 539. MAC IEEE1588 time stamp control register (MAC_TIMESTP_CTRL, address 0x4001 0700) bit description	733	Table 562. DMA Current host transmit descriptor register (DMA_CURHOST_TRANS_DES, address 0x4001 1048) bit description	752
Table 540. Time stamp snapshot dependency on register bits	734	Table 563. DMA Current host receive descriptor register (DMA_CURHOST_REC_DES, address 0x4001 104C) bit description	752
Table 541. Sub-second increment register (SUBSECOND_INCR, address 0x4001 0704) bit description	735	Table 564. DMA Current host transmit buffer address register (DMA_CURHOST_TRANS_BUF, address 0x4001 1050) bit description	753
Table 542. System time seconds register (SECONDS, address 0x4001 0708) bit description	735	Table 565. DMA Current host receive buffer address register (DMA_CURHOST_REC_BUF, address 0x4001 1054) bit description	753
Table 543. System time nanoseconds register (NANOSECONDS, address 0x4001 070C) bit description	736	Table 566. Priority scheme for transmit and receive DMA	757
Table 544. System time seconds update register (SECONDSUPDATE, address 0x4001 0710) bit description	736	Table 567. Minimum PTP clock frequency cycle	764
Table 545. System time nanoseconds update register (NANOSECONDSUPDATE, address 0x4001 0714) bit description	737	Table 568. Ordinary clock: PTP messages for snapshot	766
Table 546. Time stamp addend register (ADDEND, address 0x4001 0718) bit description	737	Table 569. End-to-end transparent clock: PTP messages for which a snapshot is taken for transparent clock implementation.	767
Table 547. Target time seconds register (TARGETSECONDS, address 0x4001 071C) bit description	737	Table 570. End-to-end transparent clock: PTP messages for which a snapshot is taken for transparent clock implementation.	767
Table 548. Target time nanoseconds register (TARGETNANOSECONDS, address 0x4001 0720) bit description	738	Table 571. Message format defined in IEEE 1588-2008	767
Table 549. System time higher words seconds register (HIGHWORD, address 0x4001 0724) bit description	738	Table 572. IPv4-UDP PTP Frame Fields Required for Control and Status	768
Table 550. Time stamp status register (TIMESTAMPSTAT, address 0x4001 0728) bit description	739	Table 573. IPv6-UDP PTP Frame Fields Required for Control and Status	769
Table 551. DMA Bus mode register (DMA_BUS_MODE, address 0x4001 1000) bit description	739	Table 574. Ethernet PTP Frame Fields Required for Control And Status	770
Table 552. Programmable burst length settings	741	Table 575. Transmit descriptor word 0 (TDES0)	788
Table 553. DMA Transmit poll demand register (DMA_TRANS_POLL_DEMAND, address 0x4001 1004) bit description	741	Table 576. Transmit descriptor word 1 (TDES1)	790
Table 554. DMA Receive poll demand register (DMA_REC_POLL_DEMAND, address 0x4001 1008) bit description	742	Table 577. Transmit descriptor word 2 (TDES2)	791
Table 555. DMA Receive descriptor list address register (DMA_REC_DES_ADDR, address 0x4001 100C) bit description	742	Table 578. Transmit descriptor word 3 (TDES3)	791
Table 556. DMA Transmit descriptor list address register (DMA_TRANS_DES_ADDR, address 0x4001 1010) bit description	743	Table 579. Transmit descriptor word 6 (TDES6)	791
Table 557. DMA Status register (DMA_STAT, address 0x4001 1014) bit description	743	Table 580. Transmit descriptor word 7 (TDES7)	791
Table 558. DMA operation mode register (DMA_OP_MODE, address 0x4001 1018) bit description	746	Table 581. Receive descriptor fields 0 (RDES0)	793
Table 559. DMA Interrupt enable register (DMA_INT_EN, address 0x4001 101C) bit description	748	Table 582. Receive descriptor fields 1 (RDES1)	795
Table 560. DMA Missed frame and buffer overflow counter register (DMA_MFRM_BUFOF, address 0x4001 1020) bit description	751	Table 583. Receive descriptor fields 2 (RDES2)	795
		Table 584. Receive descriptor fields 3 (RDES3)	795
		Table 585. Receive descriptor fields 4 (RDES4)	796
		Table 586. Receive descriptor fields 6 (RDES6)	796
		Table 587. Receive descriptor fields 7 (RDES7)	797
		Table 588. LCD clocking and power control	798
		Table 589. LCD controller pins	802
		Table 590. Pins used for single panel STN displays	803
		Table 591. Pins used for dual panel STN displays	803
		Table 592. Pins used for TFT displays	804
		Table 593. Register overview: LCD controller (base address: 0x4000 8000)	804
		Table 594. Horizontal Timing register (TIMH, address 0x4000 8000) bit description	806
		Table 595. Vertical Timing register (TIMV, address 0x4000 8004) bit description	807
		Table 596. Clock and Signal Polarity register (POL, address 0x4000 8008) bit description	808

Table 597. Line End Control register (LE, address 0x4000 800C) bit description	810	828	
Table 598. Upper Panel Frame Base register (UPBASE, address 0x4000 8010) bit description	810	Table 626. Palette data storage for STN monochrome mode.	829
Table 599. Lower Panel Frame Base register (LPBASE, address 0x4000 8014) bit description	811	Table 627. Addresses for 32 x 32 cursors	831
Table 600. LCD Control register (CTRL, address 0x4000 8018) bit description	811	Table 628. Buffer for pixel mapping for 32 x 32 pixel cursor format	832
Table 601. Interrupt Mask register (INTMSK, address 0x4000 801C) bit description	813	Table 629. Buffer to pixel mapping for 64 x 64 pixel cursor format	832
Table 602. Raw Interrupt Status register (INTRAW, address 0x4000 8020) bit description	813	Table 630. Pixel encoding	833
Table 603. Masked Interrupt Status register (INTSTAT, address 0x4000 8024) bit description	814	Table 631. Color display driven with 2 2/3 pixel data	834
Table 604. Interrupt Clear register (INTCLR, address 0x4000 8028) bit description	815	Table 632. LCD panel connections for STN single panel mode	840
Table 605. Upper Panel Current Address register (UPCURR, address 0x4000 802C) bit description	815	Table 633. LCD panel connections for STN dual panel mode	841
Table 606. Lower Panel Current Address register (LPCURR, address 0x4000 8030) bit description	815	Table 634. LCD panel connections for TFT panels	842
Table 607. Color Palette registers (PAL, address 0x4000 8200 (PAL0) to 0x4000 83FC (PAL255)) bit description	816	Table 635. SCT clocking and power control	844
Table 608. Cursor Image registers (CRSR_IMG, address 0x4000 8800 (CRSR_IMG0) to 0x4000 8BFC (CRSR_IMG255)) bit description	817	Table 636. SCT inputs and outputs	846
Table 609. Cursor Control register (CRSR_CTRL, address 0x4000 8C00) bit description	817	Table 637. Register overview: State Configurable Timer (base address 0x4000 0000)	848
Table 610. Cursor Configuration register (CRSR_CFG, address 0x4000 8C04) bit description	818	Table 638. SCT configuration register (CONFIG - address 0x4000 0000) bit description	852
Table 611. Cursor Palette register 0 (CRSR_PAL0, address 0x4000 8C08) bit description	818	Table 639. SCT control register (CTRL - address 0x4000 0004) bit description	854
Table 612. Cursor Palette register 1 (CRSR_PAL1, address 0x4000 8C0C) bit description	819	Table 640. SCT limit register (LIMIT - address 0x4000 0008) bit description	855
Table 613. Cursor XY Position register (CRSR_XY, address 0x4000 8C10) bit description	819	Table 641. SCT halt condition register (HALT - address 0x4000 000C) bit description	856
Table 614. Cursor Clip Position register (CRSR_CLIP, address 0x4000 8C14) bit description	820	Table 642. SCT stop condition register (STOP - address 0x4000 0010) bit description	856
Table 615. Cursor Interrupt Mask register (CRSR_INTMSK, address 0x4000 8C20) bit description	820	Table 643. SCT start condition register (START - address 0x4000 0014) bit description	856
Table 616. Cursor Interrupt Clear register (CRSR_INTCLR, address 0x4000 8C24) bit description	820	Table 644. SCT counter register (COUNT - address 0x4000 0040) bit description	857
Table 617. Cursor Raw Interrupt Status register (CRSR_INTRAW, address 0x4000 8C28) bit description	821	Table 645. SCT state register (STATE - address 0x4000 0044) bit description	858
Table 618. Cursor Masked Interrupt Status register (CRSR_INTSTAT, address 0x4000 8C2C) bit description	821	Table 646. SCT input register (INPUT - address 0x4000 0048) bit description	858
Table 619. FIFO bits for Little-endian Byte, Little-endian Pixel order	823	Table 647. SCT match/capture registers mode register (REGMODE - address 0x4000 004C) bit description	859
Table 620. FIFO bits for Big-endian Byte, Big-endian Pixel order	824	Table 648. SCT output register (OUTPUT - address 0x4000 0050) bit description	859
Table 621. FIFO bits for Little-endian Byte, Big-endian Pixel order	825	Table 649. SCT bidirectional output control register (OUTPUTDIRCTRL - address 0x4000 0054) bit description	860
Table 622. RGB mode data formats	826	Table 650. SCT conflict resolution register (RES - address 0x4000 0058) bit description	861
Table 623. Palette data storage for TFT modes	827	Table 651. SCT DMA 0 request register (DMAREQ0 - address 0x4000 005C) bit description	864
Table 624. Palette data storage for STN color modes	827	Table 652. SCT DMA 1 request register (DMAREQ1 - address 0x4000 0060) bit description	864
Table 625. Palette data storage for STN monochrome mode.		Table 653. SCT flag enable register (EVEN - address 0x4000 00F0) bit description	864

0x4000 00FC) bit description	865	0050) bit description.	893
Table 657. SCT match registers 0 to 15 (MATCH - address 0x4000 0100 (MATCH0) to 0x4000 4013C (MATCH15)) bit description (REGMODEn bit = 0) 866		Table 680. SCT bidirectional output control register (OUTPUTDIRCTRL - address 0x4000 0054) bit description	893
Table 658. SCT capture registers 0 to 15 (CAP - address 0x4000 0100 (CAP0) to 0x4000 013C (CAP15)) bit description (REGMODEn bit = 1).	866	Table 681. SCT conflict resolution register (RES - address 0x4000 0058) bit description	895
Table 659. SCT match reload registers 0 to 15 (MATCHREL - address 0x4000 0200 (MATCHRELOAD0) to 0x4000 023C (MATCHRELOAD15) bit description (REGMODEn bit = 0)	866	Table 682. SCT DMA 0 request register (DMAREQ0 - address 0x4000 005C) bit description	897
Table 660. SCT capture control registers 0 to 15 (CAPCTRL - address 0x4000 0200 (CAPCTRL0) to 0x4000 023C (CAPCTRL15)) bit description (REGMODEn bit = 1)	867	Table 683. SCT DMA 1 request register (DMAREQ1 - address 0x4000 0060) bit description	897
Table 661. SCT event state mask registers 0 to 15 (EVSTATEMSK - addresses 0x4000 0300 (EVSTATEMSK0) to 0x4000 0378 (EVSTATEMSK15)) bit description	867	Table 684. SCT flag enable register (EVEN - address 0x4000 00F0) bit description	898
Table 662. SCT event control register 0 to 15 (EVCTRL - address 0x4000 0304 (EVCTRL0) to 0x4000 037C (EVCTRL15)) bit description	868	Table 685. SCT event flag register (EVFLAG - address 0x4000 00F4) bit description	898
Table 663. SCT output set register 0 to 15 (OUTPUTSET - address 0x4000 0500 (OUTPUTSET0) to 0x4000 0578 (OUTPUTSET15)) bit description	869	Table 686. SCT conflict enable register (CONEN - address 0x4000 00F8) bit description	898
Table 664. SCT output clear register 0 to 15 (OUTPUTCL - address 0x4000 0504 (OUTPUTCL0) to 0x4000 057C (OUTPUTCL15)) bit description	869	Table 687. SCT conflict flag register (CONFLAG - address 0x4000 00FC) bit description	898
Table 665. Event conditions	872	Table 688. SCT match registers 0 to 15 (MATCH[0:15] - address 0x4000 0100 (MATCH0) to 0x4000 4013C (MATCH15)) bit description (REGMODEn bit = 0)	899
Table 666. Alternate address map for DMA halfword access 873		Table 689. SCT fractional match registers 0 to 5 (FRACMAT[0:5] - address 0x4000 0140 (FRACMAT0) to 0x4000 40154 (FRACMAT5)) bit description	900
Table 667. Register overview: State Configurable Timer (base address 0x4000 0000)	880	Table 690. SCT capture registers 0 to 15 (CAP[0:15] - address 0x4000 0100 (CAP0) to 0x4000 013C (CAP15)) bit description (REGMODEn bit = 1)	900
Table 668. SCT configuration register (CONFIG - address 0x4000 0000) bit description	885	Table 691. SCT match reload registers 0 to 15 (MATCHREL[0:15] - address 0x4000 0200 (MATCHREL0) to 0x4000 023C (MATCHREL15)) bit description (REGMODEn bit = 0)	901
Table 669. SCT control register (CTRL - address 0x4000 0004) bit description	886	Table 692. SCT fractional match reload registers 0 to 5 (FRACMATREL[0:5] - address 0x4000 0240 (FRACMATREL0) to 0x4000 0254 (FRACMATREL5) bit description	901
Table 670. SCT limit register (LIMIT - address 0x4000 0008) bit description	888	Table 693. SCT capture control registers 0 to 15 (CAPCTRL[0:15] - address 0x4000 0200 (CAPCTRL0) to 0x4000 023C (CAPCTRL15)) bit description (REGMODEn bit = 1).	902
Table 671. SCT halt condition register (HALT - address 0x4000 000C) bit description	888	Table 694. SCT event state mask registers 0 to 15 (EVSTATEMSK[0:15] - addresses 0x4000 0300 (EVSTATEMSK0) to 0x4000 0378 (EVSTATEMSK15)) bit description.	902
Table 672. SCT stop condition register (STOP - address 0x4000 0010) bit description	888	Table 695. SCT event control register 0 to 15 (EVCTRL - address 0x4000 0304 (EVCTRL0) to 0x4000 037C (EVCTRL15)) bit description	903
Table 673. SCT start condition register (START - address 0x4000 0014) bit description	889	Table 696. SCT output set register 0 to 15 (OUTPUTSET - address 0x4000 0500 (OUTPUTSET0) to 0x4000 0578 (OUTPUTSET15)) bit description	904
Table 674. SCT dither condition register (DITHER - address 0x4000 0018) bit description	890	Table 697. SCT output clear register 0 to 15 (OUTPUTCL - address 0x4000 0504 (OUTPUTCL0) to 0x4000 057C (OUTPUTCL15)) bit description	904
Table 675. SCT counter register (COUNT - address 0x4000 0040) bit description	890	Table 698. Dither pattern	905
Table 676. SCT state register (STATE - address 0x4000 0044) bit description	891	Table 699. Alternate address map for DMA halfword access 906	
Table 677. SCT input register (INPUT - address 0x4000 0048) bit description	891		
Table 678. SCT match/capture registers mode register (REGMODE - address 0x4000 004C) bit description	892		
Table 679. SCT output register (OUTPUT - address 0x4000			

Table 700. SCT configuration example	907	0x4008 4070 (TIMER0), 0x4008 5070 (TIMER1), 0x400C 3070 (TIMER2), 0x400C 4070 (TIMER3)) bit description	925
Table 701. Timer0/1/2/3 clocking and power control	910	Table 720. PWM clocking and power control	927
Table 702. Timer/Counter function description	911	Table 721. MOTOCN PWM pin description	930
Table 703. Timer0 inputs and outputs	913	Table 722. Register overview: Motor Control Pulse Width Modulator (MCPWM) (base address 0x400A 0000)	930
Table 704. Timer1 inputs and outputs	914	Table 723. MCPWM Control read address (CON - 0x400A 0000) bit description	931
Table 705. Timer2 inputs and outputs	914	Table 724. MCPWM Control set address (CON_SET - 0x400A 0004) bit description	933
Table 706. Timer3 inputs and outputs	915	Table 725. MCPWM Control clear address (CON_CLR - 0x400A 0008) bit description	933
Table 707. Register overview: Timer0/1/2/3 (register base addresses 0x4008 4000 (TIMER0), 0x4008 5000 (TIMER1), 0x400C 3000 (TIMER2), 0x400C 4000 (TIMER3))	916	Table 726. MCPWM Capture Control read address (CAPCON - 0x400A 000C) bit description	934
Table 708. Timer interrupt registers (IR - addresses 0x4008 4000 (TIMER0), 0x4008 5000 (TIMER1), 0x400C 3000 (TIMER2), 0x400C 4000 (TIMER3)) bit description	917	Table 727. MCPWM Capture Control set address (CAPCON_SET - 0x400A 0010) bit description	935
Table 709. Timer control register (TCR - addresses 0x4008 4004 (TIMER0), 0x4008 5004 (TIMER1), 0x400C 3004 (TIMER2), 0x400C 4004 (TIMER3)) bit description	918	Table 728. MCPWM Capture control clear register (CAPCON_CLR - address 0x400A 0014) bit description	936
Table 710. Timer counter registers (TC - addresses 0x4008 4008 (TIMER0), 0x4008 5008 (TIMER1), 0x400C 3008 (TIMER2), 0x400C 4008 (TIMER3)) bit description	918	Table 729. MCPWM Timer/Counter 0 to 2 registers (TC - 0x400A 0018 (TC0), 0x400A 001C (TC1), 0x400A 0020) (TC2) bit description	937
Table 711. Timer prescale registers (PR - addresses 0x4008 400C (TIMER0), 0x4008 500C (TIMER1), 0x400C 300C (TIMER2), 0x400C 400C (TIMER3)) bit description	919	Table 730. MCPWM Limit 0 to 2 registers (LIM - 0x400A 0024 (LIM0), 0x400A 0028 (LIM1), 0x400A 002C (LIM2)) bit description	938
Table 712. Timer prescale counter registers (PC - addresses 0x4008 4010 (TIMER0), 0x4008 5010 (TIMER1), 0x400C 3010 (TIMER2), 0x400C 4010 (TIMER3)) bit description	919	Table 731. MCPWM Match 0 to 2 registers (MAT - addresses 0x400A 0030 (MAT0), 0x400A 0034 (MAT1), 0x400A 0038 (MAT2)) bit description	938
Table 713. Timer match control registers (MCR - addresses 0x4008 4014 (TIMER0), 0x4008 5014 (TIMER1), 0x400C 3014 (TIMER2), 0x400C 4014 (TIMER3)) bit description	919	Table 732. MCPWM Dead-time register (DT - address 0x400A 003C) bit description	939
Table 714. Timer match registers (MR[0:3], addresses 0x4008 4018 (MR0) to 0x4008 4024 (M3) (TIMER0), 0x4008 5018 (MR0) to 0x4008 5024 (MR3)(TIMER1), 0x400C 3018 (MR0) to 0x400C 3024 (MR3) (TIMER2), 0x400C 4018 (MR0) to 0x400C 4024 (MR3)(TIMER3)) bit description	921	Table 733. MCPWM Communication Pattern register (CP - address 0x400A 0040) bit description	940
Table 715. Timer capture control registers (CCR - addresses 0x4008 4028 (TIMER0), 0x4008 5020 (TIMER1), 0x400C 3028 (TIMER2), 0x400C 4028 (TIMER3)) bit description	921	Table 734. MCPWM Capture read addresses (CAP - 0x400A 0044 (CAP0), 0x400A 0048 (CAP1), 0x400A 004C 9CAP2)) bit description	940
Table 716. Timer capture registers (CR[0:3], address 0x4008 402C (CR0) to 0x4008 4038 (CR3) (TIMER0), 0x4008 502C (CR0) to 0x4008 5038 (CR3) (TIMER1), 0x400C 302C (CR0) to 0x400C 3038 (CR3) (TIMER2), 0x400C 402C (CR0) to 0x400C 4038 (CR3) (TIMER3)) bit description	922	Table 735. Motor Control PWM interrupts	941
Table 717. Timer external match registers (EMR - addresses 0x4008 403C (TIMER0), 0x4008 503C (TIMER1), 0x400C 303C (TIMER2), 0x400C 403C (TIMER3)) bit description	923	Table 736. MCPWM Interrupt Enable read address (INTEN - 0x400A 0050) bit description	941
Table 718. External Match Control	924	Table 737. MCPWM interrupt enable set register (INTEN_SET - address 0x400A 0054) bit description	942
Table 719. Timer count control register (CTCR - addresses 0x4008 4070 (TIMER0), 0x4008 5070 (TIMER1), 0x400C 3070 (TIMER2), 0x400C 4070 (TIMER3)) bit description	925	Table 738. PWM interrupt enable clear register (INTEN_CLR - address 0x400A 0058) bit description	943
		Table 739. MCPWM Count Control read address (CNTCON - 0x400A 005C) bit description	943
		Table 740. MCPWM Count Control set address (CNTCON_SET - 0x400A 0060) bit description	945
		Table 741. MCPWM Count Control clear address (CNTCON_CLR - 0x400A 0064) bit description	946
		Table 742. MCPWM Interrupt flags read address (INTF - 0x400A 0068) bit description	948
		Table 743. MCPWM Interrupt Flags set address (INTF_SET - 0x400A 006C) bit description	949

Table 744. MCPWM Interrupt Flags clear address (INTF_CLR - 0x400A 0070) bit description . . . 950	Table 774. QEI Interrupt Status Clear register (CLR - 0x400C 6FE8) bit description 970
Table 745. MCPWM Capture clear address (CAP_CLR - 0x400A 0074) bit description 950	Table 775. QEI Interrupt Status Set register (SET - address 0x400C 6FEC) bit description 971
Table 746. QEI clocking and power control 957	Table 776. Encoder states 972
Table 747. QEI pin description 960	Table 777. Encoder state transitions [1] 972
Table 748. Register overview: QEI (base address 0x400C 6000) 960	Table 778. Encoder direction 973
Table 749. QEI Control register (CON - address 0x400C 6000) bit description 962	Table 779. RIT clocking and power control 975
Table 750. QEI Interrupt Status register (STAT - address 0x400C 6004) bit description 962	Table 780. Register overview: Repetitive Interrupt Timer (RIT) (base address 0x400C 0000) 976
Table 751. QEI Configuration register (CONF - address 0x400C 6008) bit description 963	Table 781. RI Compare Value register (COMPVAL - address 0x400C 0000) bit description 977
Table 752. QEI Position register (POS - address 0x400C 600C) bit description 964	Table 782. RI Mask register (MASK - address 0x400C 0004) bit description 977
Table 753. QEI Maximum Position register (MAXPOS - address 0x400C 6010) bit description 964	Table 783. RI Control register (CTRL - address 0x400C 0008) bit description 977
Table 754. QEI Position Compare register 0 (CMPOS0 - address 0x400C 6014) bit description 964	Table 784. RI Counter register (COUNTER - address 0x400C 000C) bit description 978
Table 755. QEI Position Compare register 1 (CMPOS1 - address 0x400C 6018) bit description 964	Table 785. Alarm timer clocking and power control 979
Table 756. QEI Position Compare register 2 (CMPOS2 - address 0x400C 601C) bit description 964	Table 786. Register overview: Alarm timer (base address 0x4004 0000) 980
Table 757. QEI Index Count register (INXCNT- address 0x400C 6020) bit description 965	Table 787. Downcounter register (DOWNCOUNTER - 0x4004 0000) bit description 980
Table 758. QEI Index Compare register 0 (INXCMP0 - address 0x400C 6024) bit description 965	Table 788. Preset value register (PRESET - 0x4004 0004) bit description 980
Table 759. QEI Timer Load register (LOAD - address 0x400C 6028) bit description 965	Table 789. Interrupt clear enable register (CLR_EN - 0x4004 0FD8) bit description 980
Table 760. QEI Timer register (TIME - address 0x400C 602C) bit description 965	Table 790. Interrupt set enable register (SET_EN - 0x4004 0FDC) bit description 981
Table 761. QEI Velocity register (VEL - address 0x400C 6030) bit description 965	Table 791. Interrupt status register (STATUS - 0x4004 0FE0) bit description 981
Table 762. QEI Velocity Capture register (CAP - address 0x400C 6034) bit description 966	Table 792. Interrupt enable register (ENABLE - 0x4004 0FE4) bit description 981
Table 763. QEI Velocity Compare register (VELCOMP - address 0x400C 6038) bit description 966	Table 793. Interrupt clear status register (CLR_STAT - 0x4004 0FE8) bit description 981
Table 764. QEI Digital filter on phase A input register (FILTERPHA - 0x400C 603C) bit description 966	Table 794. Interrupt set status register (SET_STAT - 0x4004 0FEC) bit description 981
Table 765. QEI Digital filter on phase B input register (FILTERPHB - 0x400C 6040) bit description 966	Table 795. WWDT clocking and power control 982
Table 766. QEI Digital filter on index input register (FILTERINX - 0x400C 6044) bit description . 966	Table 796. Register overview: Watchdog timer (base address 0x4008 0000) 984
Table 767. QEI Index acceptance window register (WINDOW - 0x400C 6048) bit description . 967	Table 797. Watchdog Mode register (MOD - 0x4008 0000) bit description 985
Table 768. QEI Index Compare register 1 (INXCMP1 - address 0x400C 604C) bit description 967	Table 798. Watchdog operating modes selection 986
Table 769. QEI Index Compare register 2 (INXCMP2 - address 0x400C 6050) bit description 967	Table 799. Watchdog Timer Constant register (TC - 0x4008 0004) bit description 986
Table 770. QEI Interrupt Enable Clear register (IEC - address 0x400C 6FD8) bit description 968	Table 800. Watchdog Feed register (FEED - 0x4008 0008) bit description 987
Table 771. QEI Interrupt Enable Set register (IES - address 0x400C 6FDC) bit description 968	Table 801. Watchdog Timer Value register (TV - 0x4008 000C) bit description 987
Table 772. QEI Interrupt Status register (INTSTAT - address 0x400C 6FE0) bit description 969	Table 802. Watchdog Timer Warning Interrupt register (WARNINT - 0x4008 0014) bit description . . . 987
Table 773. QEI Interrupt Enable register (IE - address 0x400C 6FE4) bit description 970	Table 803. Watchdog Timer Window register (WINDOW - 0x4008 0018) bit description 988
	Table 804. RTC clocking and power control 990
	Table 805. RTC pin description 991
	Table 806. Register overview: RTC (base address 0x4004 6000) 992
	Table 807. Register overview: REGFILE (base address

0x4004 1000)	992	description	1007
Table 808. Interrupt Location Register (ILR - address 0x4004 6000) bit description	993	Table 839. Event Monitor/Recorder Status Register (ERSTATUS - address 0x4004 6080) bit description	1009
Table 809. Clock Control Register (CCR - address 0x4004 6008) bit description	993	Table 840. Event Monitor/Recorder Counters Register (ERCOUNTERS - address 0x4004 6088) bit description	1010
Table 810. Counter Increment Interrupt Register (CIIR - address 0x4004 600C) bit description	994	Table 841. Event Monitor/Recorder First Stamp Register (ERFIRSTSTAMP0 - 0x0x4004 6090, ERFIRSTSTAMP1 - 0x0x4004 6094, ERFIRSTSTAMP2 - 0x4004 6098) bit description 1010	
Table 811. Alarm Mask Register (AMR - address 0x4004 6010) bit description	994	Table 842. Event Monitor/Recorder Last Stamp Register (ERLASTSTAMP0 - 0x0x4004 60A0, ERLASTSTAMP1 - 0x0x4004 60A4, ERLASTSTAMP2 - 0x4004 60A8) bit description 1011	
Table 812. Consolidated Time register 0 (CTIME0 - address 0x4004 6014) bit description	995	Table 843. USART0/2/3 clocking and power control. . .	1012
Table 813. Consolidated Time register 1 (CTIME1 - address 0x4004 6018) bit description	995	Table 844. USART0/2/3 pin description	1015
Table 814. Consolidated Time register 2 (CTIME2 - address 0x4004 601C) bit description	996	Table 845. Register overview: USART0/2/3 (base address: 0x4008 1000, 0x400C 1000, 0x400C 2000) 1016	
Table 815. Time Counter relationships and values	996	Table 846. USART Receiver Buffer Registers when DLAB = 0, Read Only (RBR - addresses 0x4008 1000 (USART0), 0x400C 1000 (USART2), 0x400C 2000 (USART3)) bit description	1018
Table 816. Time Counter registers	996	Table 847. USART Transmitter Holding Register when DLAB = 0, Write Only (THR - addresses 0x4008 1000 (USART0), 0x400C 1000 (USART2), 0x400C 2000 (USART3)) bit description	1018
Table 817. Seconds register (SEC - address 0x4004 6020) bit description	997	Table 848. USART Divisor Latch LSB Register when DLAB = 1 (DLL - addresses 0x4008 1000 (USART0), 0x400C 1000 (USART2), 0x400C 2000 (USART3)) bit description	1019
Table 818. Minutes register (MIN - address 0x4004 6024) bit description	997	Table 849. USART Divisor Latch MSB Register when DLAB = 1 (DLM - addresses 0x4008 1004 (USART0), 0x400C 1004 (USART2), 0x400C 2004 (USART3)) bit description	1019
Table 819. Hours register (HRS - address 0x4004 6028) bit description	997	Table 850. USART Interrupt Enable Register when DLAB = 0 (IER - addresses 0x4008 1004 (USART0), 0x400C 1004 (USART2), 0x400C 2004 (USART3)) bit description	1019
Table 820. Day of month register (DOM - address 0x4004 602C) bit description	997	Table 851. USART Interrupt Identification Register, read only (IIR - addresses 0x4008 1008 (USART0), 0x400C 1008 (USART2), 0x400C 2008 (USART3)) bit description	1020
Table 821. Day of week register (DOW - address 0x4004 6030) bit description	997	Table 852. USART Interrupt Handling.	1021
Table 822. Day of year register (DOY - address 0x4004 6034) bit description	998	Table 853. USART FIFO Control Register Write Only (FCR - addresses 0x4008 1008 (USART0), 0x400C 1008 (USART2), 0x400C 2008 (USART3)) bit description	1023
Table 823. Month register (MONTH - address 0x4004 6038) bit description	998	Table 854. USART Line Control Register (LCR - addresses 0x4008 100C (USART0), 0x400C 100C (USART2), 0x400C 200C (USART3)) bit description	1024
Table 824. Year register (YEAR - address 0x4004 603C) bit description	998	Table 855. USART Line Status Register Read Only (LSR - addresses 0x4008 1014 (USART0), 0x400C 1014	
Table 825. Calibration register (CALIBRATION - address 0x4004 6040) bit description	998		
Table 826. Alarm registers.	999		
Table 827. Alarm Seconds register (ASEC - address 0x4004 6060) bit description	999		
Table 828. Alarm Minutes register (AMIN - address 0x4004 6064) bit description	999		
Table 829. Alarm Hours register (AHRS - address 0x4004 6068) bit description	1000		
Table 830. Alarm Day of month register (ADOM - address 0x4004 606C) bit description	1000		
Table 831. Alarm Day of week register (ADOW - address 0x4004 6070) bit description	1000		
Table 832. Alarm Day of year register (ADOY - address 0x4004 6074) bit description	1000		
Table 833. Alarm Month register (AMON - address 0x4004 6078) bit description	1000		
Table 834. Alarm Year register (AYRS - address 0x4004 607C) bit description	1001		
Table 835. RTC clocking and power control	1003		
Table 836. Event Monitor/Recorder pin description.	1006		
Table 837. Register overview: event monitor/recorder (base address 0x4004 6000)	1006		
Table 838. Event Monitor/Recorder Control Register (ERCONTROL - address 0x4004 6084) bit			

(USART2), 0x400C 2014 (USART3)) bit description	1025	DLAB = 0 (THR - address 0x4008 2000) bit description	1052
Table 856. USART Scratch Pad Register (SCR - addresses 0x4008 101C (USART0), 0x400C 101C (USART2), 0x400C 201C (USART3)) bit description	1026	Table 875: UART1 Divisor Latch LSB Register when DLAB = 1 (DLL - address 0x4008 2000) bit description	1053
Table 857. Autobaud Control Register (ACR - addresses 0x4008 1020 (USART0), 0x400C 1020 (USART2), 0x400C 2020 (USART3)) bit description	1027	Table 876: UART1 Divisor Latch MSB Register when DLAB = 1 (DLM - address 0x4008 2004) bit description	1053
Table 858. IrDA Control Register (ICR - address 0x4000 8024) bit description	1027	Table 877: UART1 Interrupt Enable Register when DLAB = 0 (IER - address 0x4008 2004) bit description	1053
Table 859. IrDA Pulse Width	1028	Table 878: UART1 Interrupt Identification Register (IIR - address 0x4008 2008) bit description	1054
Table 860. USART Fractional Divider Register (FDR - addresses 0x4008 1028 (USART0), 0x400C 1028 (USART2), 0x400C 2028 (USART3)) bit description	1029	Table 879: UART1 Interrupt Handling	1055
Table 861. USART Oversampling Register (OSR - addresses 0x4008 102C (USART0), 0x400C 102C (USART2), 0x400C 20402C (USART3)) bit description	1030	Table 880: UART1 FIFO Control Register (FCR - address 0x4008 2008) bit description	1056
Table 862. USART Half duplex enable register (HDEN - addresses 0x4008 1040 (USART0), 0x400C 1040 (USART2), 0x400C 2040 (USART3)) bit description	1031	Table 881: UART1 Line Control Register (LCR - address 0x4008 200C) bit description	1058
Table 863. USART Smart card interface control register (SCICTRL - addresses 0x4008 1048 (USART0), 0x400C 1048 (USART2), 0x400C 2048 (USART3)) bit description	1031	Table 882: UART1 Modem Control Register (MCR - address 0x4008 2010) bit description	1058
Table 864. USART RS485 Control register (RS485CTRL - addresses 0x4008 104C (USART0), 0x400C 104C (USART2), 0x400C 204C (USART3)) bit description	1032	Table 883: UART1 Line Status Register (LSR - address 0x4008 2014) bit description	1059
Table 865. USART RS485 Address Match register (RS485ADRMATCH - addresses 0x4008 1050 (USART0), 0x400C 1050 (USART2), 0x400C 2050 (USART3)) bit description	1033	Table 884: UART1 Modem Status Register (MSR - address 0x4008 2018) bit description	1061
Table 866. USART RS485 Delay value register (RS485DLY - addresses 0x4008 1054 (USART0), 0x400C 1054 (USART2), 0x400C 2054 (USART3)) bit description	1034	Table 885: UART1 Scratch Pad Register (SCR - address 0x4008 2014) bit description	1061
Table 867. USART Synchronous mode control registers (SYNCTRL - address addresses 0x4008 1058 (USART0), 0x400C 1058 (USART2), 0x400C 2058 (USART3)) bit description	1034	Table 886: Autobaud Control Register (ACR - address 0x4008 2020) bit description	1062
Table 868. USART Transmit Enable Register (TER - addresses 0x4008 105C (USART0), 0x400C 105C (USART2), 0x400C 205C (USART3)) bit description	1036	Table 887: UART1 Fractional Divider Register (FDR - address 0x4008 2028) bit description	1062
Table 869. Fractional Divider setting look-up table	1041	Table 888: UART1 RS485 Control register (RS485CTRL - address 0x4008 204C) bit description	1063
Table 870. UART1 clocking and power control	1047	Table 889. UART1 RS485 Address Match register (RS485ADRMATCH - address 0x4008 2050) bit description	1064
Table 871: UART1 Pin description	1050	Table 890. UART1 RS485 Delay value register (RS485DLY - address 0x4008 2054) bit description	1064
Table 872: Register overview: UART1 (base address 0x4008 2000)	1051	Table 891: UART1 Transmit Enable Register (TER - address 0x4008 205C) bit description	1065
Table 873: UART1 Receiver Buffer Register when DLAB = 0 (RBR - address 0x4008 2000) bit description	1052	Table 892: Modem status interrupt generation	1066
Table 874: UART1 Transmitter Holding Register when		Table 893. SSP0/1 clocking and power control	1068
		Table 894. SSP pin description	1069
		Table 895. Register overview: SSP0 (base address 0x4008 3000)	1069
		Table 896. Register overview: SSP1 (base address 0x400C 5000)	1070
		Table 897: SSP Control Register 0 (CR0 - address 0x4008 3000 (SSP0), 0x400C 5000 (SSP1)) bit description	1071
		Table 898: SSP Control Register 1 (CR1 - address 0x4008 3004 (SSP0), 0x400C 5004 (SSP1)) bit description	1072
		Table 899: SSP Data Register (DR - address 0x4008 3008 (SSP0), 0x400C 5008 (SSP1)) bit description	1072
		Table 900: SSP Status Register (SR - address 0x4008 300C (SSP0), 0x400C 500C (SSP1)) bit description	1073
		Table 901: SSP Clock Prescale Register (CPSR - address	

0x4008 3010 (SSP0), 0x400C 5010 (SSP1)) bit description	1073	(I2S1)) bit description	1095
Table 902: SSP Interrupt Mask Set/Clear register (IMSC - address 0x4008 3014 (SSP0), 0x400C 5014 (SSP1)) bit description	1074	Table 923. I2S Transmit Mode Control register (TXMODE, address 0x400A 2030 (I2S0) and 0x400A 3030 (I2S1)) bit description	1095
Table 903: SSP Raw Interrupt Status register (RIS - address 0x4008 3018 (SSP0), RIS - 0x400C 5018 (SSP1)) bit description	1074	Table 924. I2S Receive Mode Control register (RXMODE, address 0x400A 2034 (I2S0) and 0x400A 3034 (I2S1)) bit description	1096
Table 904: SSP Masked Interrupt Status register (MIS - address 0x4008 301C (SSP0), 0x400C 501C (SSP1)) bit description	1075	Table 925. Typical transmitter master mode (PCLK - no MCLK output)	1099
Table 905: SSP interrupt Clear Register (ICR - address 0x4008 3020 (SSP0), ICR - 0x400C 5020 (SSP1)) bit description	1075	Table 926. Transmitter master mode (PCLK), with MCLK output	1100
Table 906: SSP DMA Control Register (DMACR - address 0x4008 3024 (SSP0), 0x400C 5024 (SSP1)) bit description	1076	Table 927. Transmitter master mode, sharing RX_MCLK	1101
Table 907. I2S clocking and power control	1083	Table 928. Typical Transmitter slave mode	1102
Table 908. Pin description	1086	Table 929. 4-Wire Transmitter mode	1103
Table 909. Register overview: I2S0 (base address 0x400A 2000)	1088	Table 930. Transmitter master mode (BASE_AUDIO_CLK)	1104
Table 910. Register overview: I2S1 (base address 0x400A 3000)	1089	Table 931. Transmitter master mode (External MCLK)	1105
Table 911. I2S Digital Audio Output register (DAO, address 0x400A 2000 (I2S0) and 0x400A 3000 (I2S1)) bit description	1089	Table 932. Typical Receiver master mode (PCLK - no MCLK output)	1106
Table 912. I2S Digital Audio Input register (DAI, address 0x400A 2004 (I2S0) and 0x400A 3004 (I2S1)) bit description	1090	Table 933. Receiver master mode (PCLK), with MCLK output	1107
Table 913. Transmit FIFO register (TXFIFO, address 0x400A 2008 (I2S0) and 0x400A 3008 (I2S1)) bit description	1090	Table 934. Receiver master mode, sharing TX_MCLK	1108
Table 914. I2S Receive FIFO register (RXFIFO, address 0x400A 200C (I2S0) and 0x400A 300C (I2S1)) bit description	1091	Table 935. Typical Receiver slave mode	1109
Table 915. I2S Status Feedback register (STATE, address 0x400A 2010 (I2S0) and 0x400A 3010 (I2S1)) bit description	1091	Table 936. 4-Wire Receiver mode	1110
Table 916. I2S DMA Configuration register 1 (DMA1, address 0x400A 2014 (I2S0) and 0x400A 3014 (I2S1)) bit description	1091	Table 937. Receiver master mode (BASE_AUDIO_CLK)	1111
Table 917. I2S DMA Configuration register 2 (DMA2, address 0x400A 2018 (I2S0) and 0x400A 3018 (I2S1)) bit description	1092	Table 938. Receiver master mode (External MCLK)	1112
Table 918. I2S Interrupt Request Control register (IRQ, address 0x400A 201C (I2S0) and 0x400A 301C (I2S1)) bit description	1092	Table 939. Conditions for FIFO level comparison	1113
Table 919. I2S Transmit Clock Rate register (TXRATE, address 0x400A 2020 (I2S0) and 0x400A 3020 (I2S1)) bit description	1093	Table 940. DMA and interrupt request generation	1113
Table 920. I2S Receive Clock Rate register (RXRATE, address 0x400A 2024 (I2S0) and 0x400A 3024 (I2S1)) bit description	1094	Table 941. Status feedback in the STATE register	1113
Table 921. I2S Transmit Clock Rate register (TXBITRATE, address 0x400A 2028 (I2S0) and 0x400A 3028 (I2S1)) bit description	1094	Table 942. I2C0/1 clocking and power control	1115
Table 922. I2S Receive Clock Rate register (RXBITRATE, address 0x400A 202C (I2S0) and 0x400A 302C (I2S1)) bit description	1095	Table 943. I ² C-bus pin description	1117
		Table 944. Register overview: I ² C0 (base address 0x400A 1000)	1117
		Table 945. Register overview: I ² C1 (base address 0x400E 0000)	1119
		Table 946. I ² C Control Set register (CONSET - address 0x400A 1000 (I2C0) and 0x400E 0000 (I2C1)) bit description	1120
		Table 947. I ² C Status register (STAT - address 0x400A 1004 (I2C0) and 0x400E 0004 (I2C1)) bit description	1122
		Table 948. I ² C Data register (DAT - 0x400A 1008 (I2C0) and 0x400E 0008 (I2C1)) bit description	1122
		Table 949. I ² C Slave Address register 0 (ADR0 - address 0x400A 100C (I2C0) and 0x400E 000C (I2C1)) bit description	1122
		Table 950. I ² C SCL HIGH Duty Cycle register (SCLH - address 0x400A 1010 (I2C0) and 0x400E 0010 (I2C1)) bit description	1123
		Table 951. I ² C SCL Low duty cycle register (SCLL - address 0x400A 1014 (I2C0) and 0x400E 0014 (I2C1)) bit description	1123
		Table 952. SCLL + SCLH values for selected I ² C clock values	1123
		Table 953. I ² C Control Clear register (CONCLR - address 0x400A 1018 (I2C0) and 0x400E 0018 (I2C1)) bit	

description	1124	Table 980. Message interface registers	1174
Table 954. I ² C Monitor mode control register (MMCTRL - address 0x400A 101C (I2C0) and 0x400E 001C (I2C1)) bit description	1125	Table 981. Structure of a message object in the message RAM	1175
Table 955. I ² C Slave Address registers (ADR - address 0x400A 1020 (ADR1) to 0x400A 1028 (ADR3) (I2C0) and 0x400E 0020 (ADR1) to 0x400E 0028 (ADR3) (I2C1)) bit description	1126	Table 982. CAN message interface command request registers (IF1_CMDREQ, address 0x400E 2020 (C_CAN0) and 0x400A 4020 (C_CAN1)) bit description	1175
Table 956. I ² C Data buffer register (DATA_BUFFER - address 0x400A 102C (I2C0) and 0x400E 002C (I2C1)) bit description	1127	Table 983. CAN message interface command request registers (IF2_CMDREQ, address 0x400E 2080 (C_CAN0) and 0x400A 4080 (C_CAN1)) bit description	1176
Table 957. I ² C Mask registers (MASK - address 0x400A 1030 (MASK0) to 0x400A 103C (MASK3) (I2C0) and 0x400E 0030 (MASK0) to 0x400E 003C (MASK3) (I2C1)) bit description	1128	Table 984. CAN message interface command mask registers write direction (IF1_CMDMSK_W, address 0x400E 2024 (C_CAN0) and 0x400A 4024 (C_CAN1)) bit description	1176
Table 958. CONSET used to configure Master mode	1128	Table 985. CAN message interface command mask registers write direction (IF2_CMDMSK_W, address 0x400E 2084 (C_CAN0) and 0x400A 4084 (C_CAN1)) bit description	1177
Table 959. CONSET used to configure Slave mode	1130	Table 986. CAN message interface command mask registers read direction (IF1_CMDMSK_R, address 0x400E 2024 (C_CAN0) and 0x400A 4024 (C_CAN1)) bit description	1178
Table 960. Abbreviations used to describe an I ² C operation.	1136	Table 987. CAN message interface command mask registers read direction (IF2_CMDMSK_R, address 0x400E 2084 (C_CAN0) and 0x400A 4084 (C_CAN1)) bit description	1179
Table 961. CONSET used to initialize Master Transmitter mode	1136	Table 988. CAN message interface command mask 1 registers (IF1_MSK1, address 0x400E 2028 (C_CAN0) and 0x400A 4028 (C_CAN1)) bit description	1181
Table 962. Master Transmitter mode	1138	Table 989. CAN message interface command mask 1 registers (IF2_MSK1, address 0x400E 2088 (C_CAN0) and 0x400A 4088 (C_CAN1)) bit description	1181
Table 963. Master Receiver mode	1141	Table 990. CAN message interface command mask 2 registers (IF1_MSK2, address 0x400E 202C (C_CAN0) and 0x400A 402C (C_CAN1)) bit description	1181
Table 964. ADR usage in Slave Receiver mode	1143	Table 991. CAN message interface command mask 2 registers (IF2_MSK2, 0x400E 208C (C_CAN0) and 0x400A 408C (C_CAN1)) bit description	1182
Table 965. CONSET used to initialize Slave Receiver mode	1143	Table 992. CAN message interface command arbitration 1 registers (IF1_ARB1, address 0x400E 2030 (C_CAN0) and 0x400A 4030 (C_CAN1)) bit description	1182
Table 966. Slave Receiver mode	1144	Table 993. CAN message interface command arbitration 1 registers (IF2_ARB1, address 0x400E 2090 (C_CAN0) and 0x400A 4090 (C_CAN1)) bit description	1182
Table 967. Slave Transmitter mode	1148	Table 994. CAN message interface command arbitration 2 registers (IF1_ARB2, address 0x400E 2034 (C_CAN0) and 0x400A 4034 (C_CAN1)) bit description	1183
Table 968. Miscellaneous States	1150	Table 995. CAN message interface command arbitration 2 registers (IF2_ARB2, address 0x400E 2094	
Table 969. C_CAN clocking and power control	1161		
Table 970. C_CAN pin description	1163		
Table 971. Register overview: C_CAN0 (base address 0x400E 2000)	1164		
Table 972. Register overview: C_CAN1 (base address 0x400A 4000)	1165		
Table 973. CAN control registers (CNTL, address 0x400E 2000 (C_CAN0) and 0x400A 4000 (C_CAN1)) bit description	1167		
Table 974. CAN status register (STAT, address 0x400E 2004 (C_CAN0) and 0x400A 4004 (C_CAN1)) bit description	1169		
Table 975. CAN error counter (EC, address 0x400E 2008 (C_CAN0) and 0x400A 4008 (C_CAN1)) bit description	1170		
Table 976. CAN bit timing register (BT, address 0x400E 200C (C_CAN0) and 0x400A 400C (C_CAN1)) bit description	1171		
Table 977. CAN interrupt register (INT, address 0x400E 2010 (C_CAN0) and 0x400A 4010 (C_CAN1)) bit description	1171		
Table 978. CAN test register (TEST, address 0x400E 2014 (C_CAN0) and 0x400A 4014 (C_CAN1)) bit description	1172		
Table 979. CAN baud rate prescaler extension register (BRPE, address 0x400E 2018 (C_CAN0) and 0x400A 4018 (C_CAN1)) bit description	1173		

(C_CAN0) and 0x400A 4094 (C_CAN1)) bit description	1184	Table 1014. CAN clock divider register (CLKDIV, address 0x400E 2180 (C_CAN0) and 0x400A 4180 (C_CAN1)) bit description	1193
Table 996. CAN message interface message control registers (IF1_MCTRL, address 0x400E 2038 (C_CAN0) and 0x400A 4038 (C_CAN1)) bit description	1185	Table 1015. Initialization of a transmit object	1201
Table 997. CAN message interface message control registers (IF2_MCTRL, address 0x400E 2098 (C_CAN0) and 0x400A 4098 (C_CAN1)) bit description	1186	Table 1016. Initialization of a receive object	1202
Table 998. CAN message interface data A1 registers (IF1_DA1, address 0x400E 203C (C_CAN0) and 0x400A 403C (C_CAN1)) bit description	1188	Table 1017. Parameters of the C_CAN bit time	1206
Table 999. CAN message interface data A1 registers (IF2_DA1, address 0x400E 209C (C_CAN0) and 0x400A 409C (C_CAN1)) bit description	1188	Table 1018. ADC channels for different packages	1208
Table 1000. CAN message interface data A2 registers (IF1_DA2, address 0x400E 2040 (C_CAN0) and 0x400A 4040 (C_CAN1)) bit description.	1188	Table 1019. ADC0/1 clocking and power control	1209
Table 1001. CAN message interface data A2 registers (IF2_DA2, address 0x400E 20A0 (C_CAN0) and 0x400A 40A0 (C_CAN1)) bit description	1189	Table 1020. ADC pin description	1210
Table 1002. CAN message interface data B1 registers (IF1_DB1, address 0x400E 2044 (C_CAN0) and 0x400A 4044 (C_CAN1)) bit description.	1189	Table 1021. Register overview: ADC0 (base address 0x400E 3000).	1211
Table 1003. CAN message interface data B1 registers (IF2_DB1, address 0x400E 20A4 (C_CAN0) and 0x400A 40A4 (C_CAN1)) bit description	1189	Table 1022. Register overview: ADC1 (base address 0x400E 4000).	1212
Table 1004. CAN message interface data B2 registers (IF1_DB2, address 0x400E 2048 (C_CAN0) and 0x400A 4048 (C_CAN1)) bit description.	1189	Table 1023. A/D Control register (CR - address 0x400E 3000 (ADC0) and 0x400E 4000 (ADC1)) bit description 1213	
Table 1005. CAN message interface data B2 registers (IF2_DB2, address 0x400E 20A8 (C_CAN0) and 0x400A 40A8 (C_CAN1)) bit description	1189	Table 1024. A/D Global Data register (GDR - address 0x400E 3004 (ADC0) and 0x400E 4004 (ADC1)) bit description	1214
Table 1006. CAN transmission request 1 register (TXREQ1, address 0x400E 2100 (C_CAN0) and 0x400A 4100 (C_CAN1)) bit description	1190	Table 1025. A/D Interrupt Enable register (INTEN - address 0x400E 300C (ADC0) and 0x400E 400C (ADC1)) bit description.	1215
Table 1007. CAN transmission request 2 register (TXREQ2, address 0x400E 2104 (C_CAN0) and 0x400A 4104 (C_CAN1)) bit description	1190	Table 1026. A/D Data registers (DR - addresses 0x400E 3010 (DR0) to 0x400E 302C (DR7) (ADC0); 0x400E 4010 (DR0) to 0x400E 402C (DR7) (ADC1)) bit description	1215
Table 1008. CAN new data 1 register (ND1, address 0x400E 2120 (C_CAN0) and 0x400A 4120 (C_CAN1)) bit description.	1191	Table 1027. A/D Status register (STAT - address 0x400E 3030 (ADC0) and 0x400E 4030 (ADC1)) bit description	1216
Table 1009. CAN new data 2 register (ND2, address 0x400E 2124 (C_CAN0) and 0x400A 4124 (C_CAN1)) bit description.	1191	Table 1028. DAC clocking and power control.	1218
Table 1010. CAN interrupt pending 1 register (IR1, address 0x400E 2140 (C_CAN0) and 0x400A 4140 (C_CAN1)) bit description.	1191	Table 1029. DAC pin description	1219
Table 1011. CAN interrupt pending 2 register (IR2, addresses 0x400E 2144 (C_CAN0) and 0x400A 4144 (C_CAN1)) bit description	1192	Table 1030. Register overview: DAC (base address 0x400E 1000)	1219
Table 1012. CAN message valid 1 register (MSGV1, addresses 0x400E 2160 (C_CAN0) and 0x400A 4160 (C_CAN1)) bit description	1192	Table 1031. D/A Converter register (CR - address 0x400E 1000) bit description.	1219
Table 1013. CAN message valid 2 register (MSGV2, address 0x400E 2164 (C_CAN0) and 0x400A 4164 (C_CAN1)) bit description.	1192	Table 1032. D/A Control register (CTRL - address 0x400E 1004) bit description	1220
		Table 1033. D/A Converter counter value register (CNTVAL - address 0x400E 1008) bit description	1220
		Table 1034. EEPROM clocking and power control.	1222
		Table 1035. Register overview: EEPROM (base address 0x4000 E000).	1223
		Table 1036. EEPROM command register (CMD - address 0x4000 E000) bit description	1224
		Table 1037. EEPROM read wait state register (RWSTATE - address 0x4000 E008) bit description	1224
		Table 1038. EEPROM auto programming register (AUTOPROG - address 0x4000 E00C) bit description	1225
		Table 1039. EEPROM wait state register (WSTATE - address 0x4000 E010) bit description	1225
		Table 1040. EEPROM clock divider register (CLKDIV - address 0x4000 E014) bit description	1226
		Table 1041. EEPROM power down register (PWRDWN - address 0x4000 E018) bit description	1226
		Table 1042. Interrupt enable clear register (INTENCLR - address 0x4000 EFD8) bit description.	1227
		Table 1043. Interrupt enable set register (INTENSET -	

address 0x4000 EFDC) bit description	1227
Table 1044. Interrupt status register (INTSTAT - address 0x4000 EFE0) bit description	1227
Table 1045. Interrupt enable register (INTEN - address 0x4000 EFE4) bit description	1228
Table 1046. Interrupt status clear register (INTSTATCLR - address 0x4000 EFE8) bit description	1228
Table 1047. Interrupt status set register (INTSTATSET - address 0x4000 EFEC)	1228
Table 1048. JTAG pin description	1232
Table 1049. Serial Wire Debug pin description	1232
Table 1050. Parallel Trace pin description	1233
Table 1051. JTAG TAP identification	1235
Table 1052. Abbreviations	1239

49.5 Figures

Fig 1. LPC18xx Block diagram (flashless parts)	19	Fig 47. Opcode only commands	499
Fig 2. LPC185x/3x block diagram (parts with on-chip flash) 20		Fig 48. Read commands	499
Fig 3. System memory map - flashless parts LPC1850/30/20/10 (see Figure 4 for detailed addresses of all peripherals)	25	Fig 49. EMC block diagram (SDRAM)	504
Fig 4. Memory map with peripherals - flashless parts LPC1850/30/20/10 (see Figure 3 for detailed addresses of memory blocks)	26	Fig 50. EMC block diagram (SRAM)	505
Fig 5. System memory map - parts with on-chip flash (overview)	27	Fig 51. 32 bit bank external memory interfaces (bits MW = 10)	534
Fig 6. Memory mapping - parts with on-chip flash (peripherals)	28	Fig 52. 16 bit bank external memory interfaces (bits MW = 01)	534
Fig 7. LPC18xx AHB multilayer matrix connections (flashless parts)	30	Fig 53. 8 bit bank external memory interface (bits MW = 00) 535	
Fig 8. LPC18xx AHB multilayer matrix connections (parts with on-chip flash)	31	Fig 54. High-speed USB OTG block diagram	537
Fig 9. OTP driver pointer structure	36	Fig 55. USB controller modes	543
Fig 10. Boot process flowchart for LPC18xx parts with flash 43		Fig 56. Endpoint queue head organization	590
Fig 11. Boot process for parts without flash	45	Fig 57. Endpoint queue head data structure	591
Fig 12. CMAC generation	48	Fig 58. Device state diagram	597
Fig 13. Image encryption flow	49	Fig 59. Endpoint queue head diagram	609
Fig 14. UART boot process	50	Fig 60. Software link pointers	611
Fig 15. EMC boot process	51	Fig 61. Device power state diagram	617
Fig 16. SPI boot process	51	Fig 62. Host/OTG power state diagram	618
Fig 17. SPIFI boot process	52	Fig 63. USB1 block diagram with ULPI	622
Fig 18. USB boot process	54	Fig 64. USB1 block diagram with internal full-speed PHY . 623	
Fig 19. Boot process timing	55	Fig 65. USB device driver pointer structure	666
Fig 20. IAP pointer structure	75	Fig 66. Ethernet block diagram	715
Fig 21. IAP parameter passing	76	Fig 67. Interrupt generation	750
Fig 22. Algorithm for generating a 128 bit signature	87	Fig 68. Wake-up frame filter register	755
Fig 23. AES data encryption/decryption	89	Fig 69. Networked time synchronization	759
Fig 24. AES driver pointer structure	90	Fig 70. System update using fine method	761
Fig 25. AES endianness	96	Fig 71. Propagation Delay Calculation in Clocks Supporting Peer-to-Peer Path Correction	765
Fig 26. Image encryption flow	99	Fig 72. Descriptor ring and chain structure	773
Fig 27. Boot flow for encrypted images (flashless parts)100		Fig 73. TxDMA operation in default mode	778
Fig 28. CMAC generation	103	Fig 74. TxDMA operation in OSF mode	780
Fig 29. Boot process timing	104	Fig 75. Receive DMA operation	783
Fig 30. Event router block diagram	110	Fig 76. Transmitter descriptor fields	787
Fig 31. BASE_M3_CLK ramp-up procedure	148	Fig 77. Transmit descriptor fetch (read)	788
Fig 32. CGU and CCU1/2 block diagram	149	Fig 78. Receive descriptor fields (alternate configuration) . 792	
Fig 33. CGU block diagram	152	Fig 79. LCD controller block diagram	800
Fig 34. PLL0 block diagram	178	Fig 80. Cursor movement	829
Fig 35. PLL0 with fractional divider	181	Fig 81. Cursor clipping	830
Fig 36. PLL1 block diagram	182	Fig 82. Cursor image format	831
Fig 37. RGU Block diagram	204	Fig 83. Power-up and power-down sequences	837
Fig 38. RGU Reset structure	207	Fig 84. Horizontal timing for STN displays	838
Fig 39. Block diagram of the I/O pad	332	Fig 85. Vertical timing for STN displays	839
Fig 40. Connections between GIMA and peripherals	365	Fig 86. Horizontal timing for TFT displays	839
Fig 41. GIMA input stages	367	Fig 87. Vertical timing for TFT displays	840
Fig 42. DMA controller block diagram	407	Fig 88. SCT block diagram	845
Fig 43. LLI example	436	Fig 89. SCT counter and select logic	846
Fig 44. SD/MMC block diagram	439	Fig 90. Match logic	870
Fig 45. Dual-buffer descriptor structure	483	Fig 91. Capture logic	870
Fig 46. Chain descriptor structure	484	Fig 92. Event selection	871
		Fig 93. Output slice i	871
		Fig 94. SCT interrupt generation	871
		Fig 95. SCT configuration example	907
		Fig 96. Timer block diagram	912

Fig 97. A timer cycle in which PR=2, MRx=6, and both interrupt and reset on match are enabled.	926	Fig 138. 4-Wire Transmitter mode	1103
Fig 98. A timer Cycle in Which PR=2, MRx=6, and both interrupt and stop on match are enabled.	926	Fig 139. Transmitter master mode (BASE_AUDIO_CLK)	1104
Fig 99. MCPWM Block Diagram	929	Fig 140. Transmitter master mode (External MCLK)	1105
Fig 100. Edge-aligned PWM waveform without dead time, POLA = 0	951	Fig 141. Typical Receiver master mode (PCLK - no MCLK output).	1106
Fig 101. Center-aligned PWM waveform without dead time, POLA = 0	952	Fig 142. Receiver master mode (PCLK), with MCLK output	1107
Fig 102. Edge-aligned PWM waveform with dead time, POLA = 0	952	Fig 143. Receiver master mode, sharing TX_MCLK	1108
Fig 103. Center-aligned waveform with dead time, POLA = 0	953	Fig 144. Typical Receiver slave mode	1109
Fig 104. Three-phase DC mode sample waveforms	955	Fig 145. 4-Wire Receiver mode	1110
Fig 105. Three-phase AC mode sample waveforms, edge aligned PWM mode	956	Fig 146. Receiver master mode (PLLAUDIO)	1111
Fig 106. Encoder interface block diagram.	959	Fig 147. Receiver master mode (External MCLK)	1112
Fig 107. Quadrature Encoder Basic Operation	973	Fig 148. FIFO contents for various I ² S modes	1114
Fig 108. Repetitive Interrupt Timer (RIT) block diagram	976	Fig 149. I ² C-bus configuration	1116
Fig 109. Watchdog block diagram.	988	Fig 150. Format in the Master Transmitter mode	1129
Fig 110. Early Watchdog Feed with Windowed Mode Enabled	989	Fig 151. Format of Master Receiver mode	1129
Fig 111. Correct Watchdog Feed with Windowed Mode Enabled	989	Fig 152. A Master Receiver switches to Master Transmitter after sending Repeated START	1130
Fig 112. Watchdog Warning Interrupt	989	Fig 153. Format of Slave Receiver mode	1130
Fig 113. RTC functional block diagram	991	Fig 154. Format of Slave Transmitter mode	1131
Fig 114. Event Monitor/Recorder block diagram	1005	Fig 155. I ² C serial interface block diagram.	1132
Fig 115. USART block diagram	1014	Fig 156. Arbitration procedure	1134
Fig 116. Auto-baud a) mode 0 and b) mode 1 waveform	1038	Fig 157. Serial clock synchronization	1134
Fig 117. Algorithm for setting USART dividers	1040	Fig 158. Format and states in the Master Transmitter mode	1139
Fig 118. Typical smart card application	1045	Fig 159. Format and states in the Master Receiver mode	1142
Fig 119. Smart card T = 0 waveform	1046	Fig 160. Format and states in the Slave Receiver mode	1146
Fig 120. UART1 block diagram	1049	Fig 161. Format and states in the Slave Transmitter mode	1149
Fig 121. Auto-RTS Functional Timing	1066	Fig 162. Simultaneous Repeated START conditions from two masters.	1151
Fig 122. Auto-CTS Functional Timing	1067	Fig 163. Forced access to a busy I ² C-bus.	1151
Fig 123. Texas Instruments Synchronous Serial Frame Format: a) Single and b) Continuous/back-to-back Two Frames Transfer.	1076	Fig 164. Recovering from a bus obstruction caused by a LOW level on SDA	1152
Fig 124. SPI frame format with CPOL=0 and CPHA=0 (a) Single and b) Continuous Transfer).	1077	Fig 165. C_CAN block diagram	1162
Fig 125. SPI frame format with CPOL=0 and CPHA=1.	1078	Fig 166. Block diagram of a message object transfer	1174
Fig 126. SPI frame format with CPOL = 1 and CPHA = 0 (a) Single and b) Continuous Transfer).	1079	Fig 167. CAN core in Silent mode	1195
Fig 127. SPI Frame Format with CPOL = 1 and CPHA = 1.	1080	Fig 168. CAN core in Loop-back mode.	1196
Fig 128. Microwire frame format (single transfer)	1081	Fig 169. CAN core in Loop-back mode combined with Silent mode.	1196
Fig 129. Microwire frame format (continuous transfers)	1082	Fig 170. Block diagram of a message object transfer	1198
Fig 130. Microwire frame format setup and hold details	1082	Fig 171. Reading a message from the FIFO buffer to the message buffer	1204
Fig 131. WS signal connections	1085	Fig 172. Bit timing	1207
Fig 132. Simple I2S configurations and bus timing	1087	Fig 173. DAC control with DMA interrupt and timer	1221
Fig 133. I2S clocking and pin connections	1098	Fig 174. ARM Standard JTAG Connector.	1233
Fig 134. Typical transmitter master mode (PCLK - no MCLK output)	1099	Fig 175. Cortex Debug Connector	1234
Fig 135. Transmitter master mode (PCLK), with MCLK output.	1100	Fig 176. Cortex Debug + ETM Connector	1234
Fig 136. Transmitter master mode, sharing RX_MCLK	1101		
Fig 137. Typical Transmitter slave mode	1102		

49.6 Contents

Chapter 1: LPC18xx Introductory information

1.1	Introduction	12	1.4	Ordering information (parts with on-chip flash).	16
1.2	Features	12	1.5	Block diagram (flashless parts	
1.3	Ordering information (flashless parts			LPC1850/30/20/10).	19
	LPC1850/30/20/10)	15	1.6	Block diagram (parts with on-chip flash)	20

Chapter 2: LPC18xx Memory mapping

2.1	How to read this chapter	21	2.3.5	Memory retention in the Power-down modes	23
2.2	Basic configuration	21	2.3.6	Memory Protection Unit (MPU)	23
2.3	Memory configuration	21	2.4	Memory map (flashless parts LPC1850/30/20/10)	25
2.3.1	On-chip static RAM	21	2.5	Memory map (parts with on-chip flash)	27
2.3.2	Bit banding	22	2.6	AHB multilayer matrix configuration	29
2.3.3	On-chip flash	22			
2.3.4	On-chip EEPROM	23			

Chapter 3: LPC18xx One-Time Programmable (OTP) memory and API

3.1	How to read this chapter	32	3.4	Register description	34
3.2	Features	32	3.5	OTP API	36
3.3	General description	33	3.5.1	OTP function allocation	37
			3.5.1.1	OTP API error codes	38

Chapter 4: LPC18xx Boot ROM

4.1	How to read this chapter	39	4.3.6	Boot modes	49
4.1.1	Determine the boot code version	39	4.3.6.1	UART boot mode	49
4.2	Features	39	4.3.6.2	EMC boot mode	50
4.3	Functional description	39	4.3.6.3	SPI boot mode	51
4.3.1	Boot process for parts with internal flash	42	4.3.6.4	SPIFI boot mode	51
4.3.2	Boot process for parts without flash	43	4.3.6.4.1	Supported QSPI devices	52
4.3.3	AES capable parts	46	4.3.6.5	USB boot mode	54
4.3.4	Boot image header format	46	4.3.7	Boot process timing	54
4.3.5	Boot image creation	47	4.3.8	UART ISP	55
4.3.5.1	CMAC	47			

Chapter 5: LPC18xx flash programming/ISP and IAP

5.1	How to read this chapter	56	5.4.5.6	Interrupts during IAP	60
5.2	Basic configuration	56	5.4.5.7	RAM used by ISP	60
5.3	Features	56	5.4.5.8	RAM used by IAP command handler	60
5.4	General description	57	5.4.6	Flash signature generation	61
5.4.1	Sampling of pin P2_7	58	5.5	Sector numbers	62
5.4.2	Boot process for flashless parts	58	5.6	Code Read Protection (CRP)	63
5.4.3	Boot process for parts with internal flash	59	5.7	ISP commands	65
5.4.4	Memory map after any reset	59	5.7.1	Unlock <Unlock code>	65
5.4.4.1	Criterion for Valid User Code	59	5.7.2	Set Baud Rate <Baud Rate> <stop bit>	66
5.4.5	Communication protocol	59	5.7.3	Echo <setting>	66
5.4.5.1	ISP command format	59	5.7.4	Write to RAM <start address> <number of bytes>	66
5.4.5.2	ISP response format	60	5.7.5	Read Memory <address> <no. of bytes>	67
5.4.5.3	ISP data format	60	5.7.6	Prepare sectors for write operation <start sector	
5.4.5.4	ISP flow control	60		number> <end sector number> <flash bank>	68
5.4.5.5	ISP command abort	60			

5.7.7	Copy RAM to Flash <flash address> <RAM address> <no of bytes>	69	5.8.8	Read device serial number	81
5.7.8	Go <address> <mode>	70	5.8.9	Compare <address1> <address2> <no of bytes>	81
5.7.9	Erase sectors <start sector number> <end sector number> <flash bank>	70	5.8.10	Re-invoke ISP	82
5.7.10	Blank check sectors <sector number> <end sector number> <flash bank>	71	5.8.11	Erase page.	82
5.7.11	Read Part Identification number	71	5.8.12	Set active boot flash bank	82
5.7.12	Read Boot Code version number	73	5.9	ISP/IAP Return Codes	83
5.7.13	Read device serial number	73	5.10	JTAG flash programming interface	84
5.7.14	Compare <address1> <address2> <no of bytes>	73	5.11	Flash signature generation	84
5.7.15	Set active boot flash bank <flash bank>.	74	5.11.1	Register description for signature generation	84
5.8	IAP commands	75	5.11.1.1	Signature generation address and control registers	85
5.8.1	IAP Initialization	77	5.11.1.2	Signature generation result registers	85
5.8.2	Prepare sectors for write operation.	78	5.11.1.3	Flash Module Status register	86
5.8.3	Copy RAM to Flash	79	5.11.1.4	Flash Module Status Clear register	86
5.8.4	Erase Sectors	79	5.11.2	Algorithm and procedure for signature generation	87
5.8.5	Blank check sectors	80		Signature generation	87
5.8.6	Read part identification number	80		Content verification	87
5.8.7	Read Boot Code version number	80			

Chapter 6: LPC18xx Security API

6.1	How to read this chapter	88	6.5	Functional description	94
6.2	Features	88	6.5.1	Using the AES API without DMA	94
6.3	General description	88	6.5.2	Using the AES API with DMA	94
6.4	AES API	90	6.5.3	AES Decryption	95
6.4.1	AES functions	91	6.5.4	Use of AES keys	95
6.4.2	AES ROM driver variables	93	6.5.5	Endianness	95
6.4.3	AES API error codes	94	6.5.6	Storing AES keys in Deep power-down mode	96

Chapter 7: LPC18xx Boot ROM for secure parts

7.1	How to read this chapter	97	7.3.2	Encryption and boot flow	97
7.1.1	Determine the boot code version	97	7.3.2.1	Development mode	101
7.2	Features	97	7.3.3	Boot image header format	101
7.3	Functional description	97	7.3.4	CMAC	102
7.3.1	Boot sources	97	7.3.5	Boot process timing	103

Chapter 8: LPC18xx Nested Vectored Interrupt Controller (NVIC)

8.1	How to read this chapter	105	8.5	Pin description	105
8.2	Basic configuration	105	8.6	Interrupt sources	106
8.3	Features	105	8.7	Register description	107
8.4	General description	105			

Chapter 9: LPC18xx Event router

9.1	How to read this chapter	109	9.6.3	Clear event enable register	119
9.2	Basic configuration	109	9.6.4	Set event enable register	120
9.3	General description	109	9.6.5	Event status register	121
9.4	Event router inputs	110	9.6.6	Event enable register	122
9.5	Pin description	112	9.6.7	Clear event status register	124
9.6	Register description	112	9.6.8	Set event status register	125
9.6.1	Level configuration register	112			
9.6.2	Edge configuration register	116			

Chapter 10: LPC18xx Configuration Registers (CREG)

10.1	How to read this chapter	127	10.4.6	Flash Accelerator Configuration register for flash bank A	135
10.2	Basic configuration	127	10.4.7	Flash Accelerator Configuration register for flash bank B	136
10.3	Features	128	10.4.8	ETB SRAM configuration register	137
10.4	Register description	129	10.4.9	CREG6 control register	137
10.4.1	CREG0 control register	130	10.4.10	Chip ID register	139
10.4.2	CREG1 control register	131	10.4.11	USB0 frame length adjust register	139
10.4.3	ARM Cortex-M3 memory mapping register	132	10.4.12	USB1 frame length adjust register	140
10.4.4	CREG5 control register	132			
10.4.5	DMA mux control register	132			

Chapter 11: LPC18xx Power Management Controller (PMC)

11.1	How to read this chapter	142	11.3	Register description	144
11.2	General description	142	11.3.1	Hardware sleep event enable register PDO_SLEEP0_HW_ENA	145
11.2.1	Active mode	142	11.3.2	Power-down modes register PDO_SLEEP0_MODE	145
11.2.2	Sleep mode	142	11.4	Functional description	145
11.2.3	Deep-sleep mode	143	11.4.1	Run-time programming	145
11.2.4	Power-down mode	143			
11.2.5	Deep power-down	143			
11.2.6	Memory retention in Power-down modes	144			

Chapter 12: LPC18xx Clock Generation Unit (CGU)

12.1	How to read this chapter	146	12.6.10	BASE_USB0_CLK control register	170
12.2	Basic configuration	146	12.6.11	BASE_USB1_CLK control register	171
12.2.1	Configuring the BASE_M3_CLK for high operating frequencies	146	12.6.12	BASE_M3_CLK to BASE_UART3_CLK control registers	172
12.2.1.1	Changing the BASE_M3_CLK after power-up, reset, or deep power-down mode	146	12.6.13	BASE_OUT_CLK register	173
12.2.1.2	Changing the BASE_M3_CLK after waking up from deep-sleep or power-down modes	147	12.6.14	BASE_AUDIO_CLK register	174
12.3	Features	148	12.6.15	BASE_CGU_OUT0_CLK to BASE_CGU_OUT1_CLK register	175
12.4	General description	148	12.7	Functional description	176
12.5	Pin description	153	12.7.1	32 kHz oscillator	176
12.6	Register description	153	12.7.2	IRC	176
12.6.1	Frequency monitor register	156	12.7.3	Crystal oscillator	176
12.6.2	Crystal oscillator control register	157	12.7.4	PLL0 (PLL0USB and PLL0AUDIO)	176
12.6.3	PLL0USB registers	158	12.7.4.1	Features	177
12.6.3.1	PLL0USB status register	158	12.7.4.2	PLL0 description	177
12.6.3.2	PLL0USB control register	158	12.7.4.3	Use of PLL0 operating modes	178
12.6.3.3	PLL0USB M-divider register	159	12.7.4.3.1	Normal Mode	178
12.6.3.4	PLL0USB NP-divider register	161	12.7.4.3.2	Mode 1a: Normal operating mode without post-divider and without pre-divider	179
12.6.4	PLL0AUDIO registers	162	12.7.4.3.3	Mode 1b: Normal operating mode with post-divider and without pre-divider	179
12.6.4.1	PLL0AUDIO status register	162	12.7.4.3.4	Mode 1c: Normal operating mode without post-divider and with pre-divider	179
12.6.4.2	PLL0AUDIO control register	162	12.7.4.3.5	Mode 1d: Normal operating mode with post-divider and with pre-divider	180
12.6.4.3	PLL0AUDIO M-divider register	163	12.7.4.3.6	Mode 3: Power down mode (pd)	180
12.6.4.4	PLL0AUDIO NP-divider register	164	12.7.4.4	Settings for USB0	180
12.6.4.5	PLL0AUDIO fractional divider register	165	12.7.4.5	Usage notes	180
12.6.5	PLL1 registers	165	12.7.5	Fractional divider for PLL0AUDIO	180
12.6.5.1	PLL1 status register	165	12.7.6	PLL1	181
12.6.5.2	PLL1 control register	166	12.7.6.1	Features	181
12.6.6	Integer divider register A	167	12.7.6.2	PLL1 description	182
12.6.7	Integer divider register B, C, D	168	12.7.6.3	Lock detector	182
12.6.8	Integer divider register E	169			
12.6.9	BASE_SAFE_CLK control register	170			

12.7.6.4	Power-down control	182		Power-down mode	184
12.7.6.5	Selectable feedback divider clock	183	12.8	Example CGU configurations	185
12.7.6.6	Direct output mode	183	12.8.1	Programming the CGU for Deep-sleep and Power-down modes	185
12.7.6.7	Divider ratio programming	183	12.8.2	Programming the CGU for using I2S at peripheral clock rate of 30 MHz	185
	Pre-divider	183	12.8.3	PLL0USB settings for USB0 applications	185
	Post-divider	183	12.8.4	PLL0AUDIO settings for audio applications	186
	Feedback divider	183	12.8.4.1	Using the fractional divider	186
12.7.6.8	Frequency selection	183	12.8.4.2	Bypassing the fractional divider	188
	Integer mode	183			
	Non-integer mode	184			
	Direct mode	184			

Chapter 13: LPC18xx Clock Control Unit (CCU)

13.1	How to read this chapter	190	13.5	Register description	193
13.2	Basic configuration	190	13.5.1	Power mode register	197
13.3	Features	190	13.5.2	Base clock status register	197
13.4	General description	190	13.5.3	CCU1/2 branch clock configuration registers	198
			13.5.4	CCU1/2 branch clock status registers	200

Chapter 14: LPC18xx Reset Generation Unit (RGU)

14.1	How to read this chapter	203	14.4.4.1	Reset external status register 1 for PERIPH_RST	223
14.2	Basic configuration	203	14.4.4.2	Reset external status register 2 for MASTER_RST	224
14.2.1	How to reset the LPC18xx by software	203	14.4.4.3	Reset external status register 5 for CREG_RST	224
14.3	General description	203	14.4.4.4	Reset external status registers for PERIPHERAL_RESET	224
14.3.1	Reset hierarchy	206	14.4.4.5	Reset external status registers for MASTER_RESET	224
14.4	Register overview	207	14.5	Functional description	225
14.4.1	RGU reset control register	210	14.5.1	Determine the cause of a core reset	225
14.4.2	RGU reset status register	213			
14.4.3	RGU reset active status register	219			
14.4.4	Reset external status registers	223			

Chapter 15: LPC18xx Pin configuration

15.1	How to read this chapter	226	15.2	Pin description	226
-------------	---------------------------------	------------	-------------	------------------------	------------

Chapter 16: LPC18xx System Control Unit (SCU) IO configuration

16.1	How to read this chapter	331	16.4.2	Pin configuration registers for high-drive pins	351
16.2	Basic configuration	331	16.4.3	Pin configuration registers for high-speed pins	353
16.3	General description	331	16.4.4	Pin configuration register for USB1 pins USB1_DP/USB1_DM	353
16.3.1	Digital pin function	332	16.4.5	Pin configuration register for open-drain I ² C-bus pins	354
16.3.2	Digital pin mode	332	16.4.6	ADC0 function select register	355
16.3.3	Input buffer	333	16.4.7	ADC1 function select register	357
16.3.4	Programmable glitch filter	333	16.4.8	Analog function select register	358
16.3.5	Programmable slew rate	333	16.4.8.1	Measuring the band gap	359
16.3.6	High-speed pins	333	16.4.9	EMC clock delay register	359
16.3.7	High-drive pins	333	16.4.10	SD/MMC delay register	360
16.3.8	I ² C0-bus pins	333	16.4.11	Pin interrupt select register 0	360
16.3.9	USB1 USB1_DP/USB1_DM pins	333	16.4.12	Pin interrupt select register 1	362
16.3.10	EMC signal delay control	334			
16.3.11	Pin multiplexing	334			
16.4	Register description	343			
16.4.1	Pin configuration registers for normal-drive pins	350			

Chapter 17: LPC18xx Global Input Multiplexer Array (GIMA)

17.1	How to read this chapter	364		
17.2	Basic configuration	364		
17.3	General description	364		
17.3.1	GIMA event input selection	364		
17.3.2	GIMA clock synchronization	367		
17.4	Register description	368		
17.4.1	Timer 0 CAP0_0 capture input multiplexer (CAP0_0_IN)	370	17.4.14	Timer 3 CAP3_1 capture input multiplexer (CAP3_1_IN) 378
17.4.2	Timer 0 CAP0_1 capture input multiplexer (CAP0_1_IN)	370	17.4.15	Timer 3 CAP3_2 capture input multiplexer (CAP3_2_IN) 378
17.4.3	Timer 0 CAP0_2 capture input multiplexer (CAP0_2_IN)	371	17.4.16	Timer 3 CAP3_3 capture input multiplexer (CAP3_3_IN) 379
17.4.4	Timer 0 CAP0_3 capture input multiplexer (CAP0_3_IN)	372	17.4.17	SCT CTIN_0 capture input multiplexer (CTIN_0_IN) 379
17.4.5	Timer 1 CAP1_0 capture input multiplexer (CAP1_0_IN)	372	17.4.18	SCT CTIN_1 capture input multiplexer (CTIN_1_IN) 380
17.4.6	Timer 1 CAP1_1 capture input multiplexer (CAP1_1_IN)	373	17.4.19	SCT CTIN_2 capture input multiplexer (CTIN_2_IN) 381
17.4.7	Timer 1 CAP1_2 capture input multiplexer (CAP1_2_IN)	373	17.4.20	SCT CTIN_3 capture input multiplexer (CTIN_3_IN) 381
17.4.8	Timer 1 CAP1_3 capture input multiplexer (CAP1_3_IN)	374	17.4.21	SCT CTIN_4 capture input multiplexer (CTIN_4_IN) 382
17.4.9	Timer 2 CAP2_0 capture input multiplexer (CAP2_0_IN)	375	17.4.22	SCT CTIN_5 capture input multiplexer (CTIN_5_IN) 382
17.4.10	Timer 2 CAP2_1 capture input multiplexer (CAP2_1_IN)	375	17.4.23	SCT CTIN_6 capture input multiplexer (CTIN_6_IN) 383
17.4.11	Timer 2 CAP2_2 capture input multiplexer (CAP2_2_IN)	376	17.4.24	SCT CTIN_7 capture input multiplexer (CTIN_7_IN) 384
17.4.12	Timer 2 CAP2_3 capture input multiplexer (CAP2_3_IN)	376	17.4.25	Event router input 13 multiplexer (EVENTROUTER_13_IN) 384
17.4.13	Timer 3 CAP3_0 capture input multiplexer (CAP3_0_IN)	377	17.4.26	Event router input 14 multiplexer (EVENTROUTER_14_IN) 385
			17.4.27	Event router input 16 multiplexer (EVENTROUTER_16_IN) 385
			17.4.28	ADC start0 input multiplexer (ADCSTART0_IN) 386
			17.4.29	ADC start1 input multiplexer (ADCSTART1_IN) 386

Chapter 18: LPC18xx GPIO

18.1	How to read this chapter	388	18.5.1.5	Pin interrupt active level (falling edge) interrupt enable register 396
18.2	Basic configuration	388	18.5.1.6	Pin interrupt active level (falling edge) interrupt set register 396
18.3	Features	389	18.5.1.7	Pin interrupt active level (falling edge interrupt) clear register 396
18.3.1	GPIO pin interrupt features	389	18.5.1.8	Pin interrupt rising edge register 397
18.3.2	GPIO group interrupt features	389	18.5.1.9	Pin interrupt falling edge register 397
18.3.3	GPIO port features	389	18.5.1.10	Pin interrupt status register 398
18.4	General description	389	18.5.2	GPIO GROUP0/GROUP1 interrupt register description 398
18.4.1	GPIO pin interrupts	389	18.5.2.1	Grouped interrupt control register 398
18.4.2	GPIO group interrupt	389	18.5.2.2	GPIO grouped interrupt port polarity registers 399
18.4.3	GPIO port	390	18.5.2.3	GPIO grouped interrupt port enable registers 399
18.5	Register description	390	18.5.3	GPIO port register description 400
18.5.1	GPIO pin interrupts register description	394	18.5.3.1	GPIO port byte pin registers 400
18.5.1.1	Pin interrupt mode register	394	18.5.3.2	GPIO port word pin registers 400
18.5.1.2	Pin interrupt level (rising edge) interrupt enable register	394	18.5.3.3	GPIO port direction registers 401
18.5.1.3	Pin interrupt level (rising edge) interrupt set register	395	18.5.3.4	GPIO port mask registers 401
18.5.1.4	Pin interrupt level (rising edge interrupt) clear register	395	18.5.3.5	GPIO port pin registers 401

18.5.3.6	GPIO masked port pin registers	401	18.6.2	GPIO output	403
18.5.3.7	GPIO port set registers	402	18.6.3	Masked I/O	404
18.5.3.8	GPIO port clear registers	402	18.6.4	GPIO Interrupts	404
18.5.3.9	GPIO port toggle registers	402	18.6.4.1	Pin interrupts	404
18.6	Functional description	403	18.6.4.2	Group interrupts	405
18.6.1	Reading pin state	403	18.6.5	Recommended practices	405

Chapter 19: LPC18xx General Purpose DMA (GPDMA) controller

19.1	How to read this chapter	406	19.7.1.2	Control logic and register bank	426
19.2	Basic configuration	406	19.7.1.3	DMA request and response interface	426
19.3	Features	406	19.7.1.4	Channel logic and channel register bank	426
19.4	General description	407	19.7.1.5	Interrupt request	426
19.5	DMA system connections	407	19.7.1.6	AHB master interface	426
19.5.1	DMA request signals	409	19.7.1.6.1	Bus and transfer widths	426
19.5.2	DMA response signals	410	19.7.1.6.2	Endian behavior	426
19.6	Register description	410	19.7.1.6.3	Error conditions	429
19.6.1	DMA Interrupt Status Register	412	19.7.1.7	Channel hardware	429
19.6.2	DMA Interrupt Terminal Count Request Status Register	412	19.7.1.8	DMA request priority	429
19.6.3	DMA Interrupt Terminal Count Request Clear Register	413	19.7.1.9	Interrupt generation	429
19.6.4	DMA Interrupt Error Status Register	413	19.8	Using the DMA controller	429
19.6.5	DMA Interrupt Error Clear Register	413	19.8.1	Programming the DMA controller	429
19.6.6	DMA Raw Interrupt Terminal Count Status Register	414	19.8.1.1	Enabling the DMA controller	429
19.6.7	DMA Raw Error Interrupt Status Register	414	19.8.1.2	Disabling the DMA controller	429
19.6.8	DMA Enabled Channel Register	415	19.8.1.3	Enabling a DMA channel	429
19.6.9	DMA Software Burst Request Register	415	19.8.1.4	Disabling a DMA channel	430
19.6.10	DMA Software Single Request Register	415		Disabling a DMA channel and losing data in the FIFO	430
19.6.11	DMA Software Last Burst Request Register	416		Disabling the DMA channel without losing data in the FIFO	430
19.6.12	DMA Software Last Single Request Register	416	19.8.1.5	Setting up a new DMA transfer	430
19.6.13	DMA Configuration Register	417	19.8.1.6	Halting a DMA channel	430
19.6.14	DMA Synchronization Register	417	19.8.1.7	Programming a DMA channel	430
19.6.15	DMA Channel registers	418	19.8.2	Flow control	431
19.6.16	DMA Channel Source Address Registers	418	19.8.2.1	Peripheral-to-memory or memory-to-peripheral DMA flow	431
19.6.17	DMA Channel Destination Address registers	419	19.8.2.2	Peripheral-to-peripheral DMA flow	432
19.6.18	DMA Channel Linked List Item registers	419	19.8.2.3	Memory-to-memory DMA flow	433
19.6.19	DMA channel control registers	419	19.8.3	Interrupt requests	433
19.6.19.1	Protection and access information	422	19.8.3.1	Hardware interrupt sequence flow	433
19.6.20	Channel Configuration registers	422	19.8.4	Address generation	434
19.6.20.1	Lock control	425	19.8.4.1	Word-aligned transfers across a boundary	434
19.6.20.2	Flow control and transfer type	425	19.8.5	Scatter/gather	434
19.7	Functional description	426	19.8.5.1	Linked list items	434
19.7.1	DMA controller functional description	426	19.8.5.1.1	Programming the DMA controller for scatter/gather DMA	435
19.7.1.1	AHB slave interface	426	19.8.5.1.2	Example of scatter/gather DMA	435

Chapter 20: LPC18xx SD/MMC interface

20.1	How to read this chapter	438	20.6.2	Power Enable Register (PWREN)	444
20.2	Basic configuration	438	20.6.3	Clock Divider Register (CLKDIV)	444
20.3	Features	438	20.6.4	SD Clock Source Register (CLKSRC)	445
20.4	General description	439	20.6.5	Clock Enable Register (CLKENA)	445
20.5	Pin description	440	20.6.6	Time-out Register (TMOUT)	445
20.6	Register description	440	20.6.7	Card Type Register (CTYPE)	446
20.6.1	Control Register (CTRL)	441	20.6.8	Block Size Register (BLKSIZ)	446
			20.6.9	Byte Count Register (BYTCNT)	446

20.6.10	Interrupt Mask Register (INTMASK)	446	20.7.4.4	No-Data Command With or Without Response Sequence	467
20.6.11	Command Argument Register (CMDARG)	447	20.7.4.5	Data Transfer Commands	468
20.6.12	Command Register (CMD)	448	20.7.4.6	Single-Block or Multiple-Block Read	469
20.6.13	Response Register 0 (RESP0)	450	20.7.4.7	Single-Block or Multiple-Block Write	470
20.6.14	Response Register 1 (RESP1)	451	20.7.4.8	Stream Read	472
20.6.15	Response Register 2 (RESP2)	451	20.7.4.9	Stream Write	472
20.6.16	Response Register 3 (RESP3)	451	20.7.4.10	Sending Stop or Abort in Middle of Transfer	472
20.6.17	Masked Interrupt Status Register (MINTSTS)	451	20.7.5	Suspend or Resume Sequence	473
20.6.18	Raw Interrupt Status Register (RINTSTS)	452	20.7.5.1	Read_Wait Sequence	475
20.6.19	Status Register (STATUS)	454	20.7.5.2	CE-ATA Data Transfer Commands	475
20.6.20	FIFO Threshold Watermark Register (FIFOTH)	455	20.7.5.2.1	Reset and Device Recovery	475
20.6.21	Card Detect Register (CDETECT)	456	20.7.5.2.2	ATA Task File Transfer	476
20.6.22	Write Protect Register (WRTPRT)	456	20.7.5.2.3	ATA Payload Transfer Using RW_MULTIPLE_BLOCK (RW_BLK)	477
20.6.23	Transferred CIU Card Byte Count Register (TCBCNT)	457	20.7.5.2.4	Sending Command Completion Signal Disable	479
20.6.24	Transferred Host to BIU-FIFO Byte Count Register (TBBCNT)	457	20.7.5.2.5	Recovery after Command Completion Signal Time-out	479
20.6.25	Debounce Count Register (DEBNCE)	457	20.7.5.2.6	Reduced ATA Command Set	479
20.6.26	Hardware Reset (RST_N)	457	20.7.5.3	Controller/DMA/FIFO Reset Usage	481
20.6.27	Bus Mode Register (BMOD)	458	20.7.5.4	Error Handling	482
20.6.28	Poll Demand Register (PLDMND)	458	20.7.6	DMA descriptors	483
20.6.29	Descriptor List Base Address Register (DBADDR)	459	20.7.6.1	SD/MMC DMA descriptors	484
20.6.30	Internal DMAC Status Register (IDSTS)	459	20.7.6.1.1	SD/MMC DMA descriptor DESC0	484
20.6.31	Internal DMAC Interrupt Enable Register (IDINTEN)	460	20.7.6.1.2	SD/MMC DMA descriptor DESC1	485
20.6.32	Current Host Descriptor Address Register (DSCADDR)	461	20.7.6.1.3	SD/MMC DMA descriptor DESC2	485
20.6.33	Current Buffer Descriptor Address Register (BUFADDR)	461	20.7.6.1.4	SD/MMC DMA descriptor DESC3	485
20.7	Functional description	461	20.7.6.2	Initialization	486
20.7.1	Power/pull-up control and card detection unit	461	20.7.6.3	Host bus burst access	486
20.7.2	Auto-Stop	462	20.7.6.4	Host data buffer alignment	486
20.7.3	Software/hardware restrictions	463	20.7.6.5	Buffer size calculations	486
20.7.4	Programming sequence	465	20.7.6.6	Transmission	487
20.7.4.1	Initialization	465	20.7.6.7	Reception	487
20.7.4.2	Enumerated Card Stack	465	20.7.6.8	Interrupts	488
20.7.4.3	Clock Programming	466	20.7.6.9	Abort	488
			20.7.6.10	FBE scenarios	489
			20.7.6.11	FIFO overflow and underflow	489
			20.7.6.12	Programming of PBL and watermark levels	489

Chapter 21: LPC18xx SPI Flash Interface (SPIFI)

21.1	How to read this chapter	490	21.6.4	SPIFI intermediate data register	495
21.2	Basic configuration	490	21.6.5	SPIFI cache limit register	495
21.3	Features	490	21.6.6	SPIFI data register	495
21.4	General description	490	21.6.7	SPIFI memory command register	496
21.5	Pin description	491	21.6.8	SPIFI status register	497
21.6	Register description	491	21.7	Functional description	498
21.6.1	SPIFI control register	492	21.7.1	Data transfer	498
21.6.2	SPIFI command register	493	21.7.2	Software requirements and capabilities	500
21.6.3	SPIFI address register	495	21.7.3	Peripheral mode DMA operation	501

Chapter 22: LPC18xx External Memory Controller (EMC)

22.1	How to read this chapter	502	22.4	General description	504
22.2	Basic configuration	502	22.4.1	Memory bank select	505
22.3	Features	503	22.5	Pin description	506

22.6	Register description	506	22.6.20	Dynamic Memory RAS/CAS Delay registers	521
22.6.1	EMC Control register	509	22.6.21	Static Memory Configuration registers	522
22.6.2	EMC Status register	510	22.6.22	Static Memory Write Enable Delay registers	524
22.6.3	EMC Configuration register	511	22.6.23	Static Memory Output Enable Delay registers	524
22.6.4	Dynamic Memory Control register	511	22.6.24	Static Memory Read Delay registers	525
22.6.5	Dynamic Memory Refresh Timer register	512	22.6.25	Static Memory Page Mode Read Delay registers	525
22.6.6	Dynamic Memory Read Configuration register	513	22.6.26	Static Memory Write Delay registers	526
22.6.7	Dynamic Memory Precharge Command Period register	514	22.6.27	Static Memory Turn-around Delay registers	526
22.6.8	Dynamic Memory Active to Precharge Command Period register	514	22.7	Functional description	528
22.6.9	Dynamic Memory Self Refresh Exit Time register	515	22.7.1	AHB slave register interface	528
22.6.10	Dynamic Memory Last Data Out to Active Time register	515	22.7.2	AHB slave memory interface	528
22.6.11	Dynamic Memory Data In to Active Command Time register	515	22.7.2.1	Memory transaction endianness	528
22.6.12	Dynamic Memory Write Recovery Time register	516	22.7.2.2	Memory transaction size	528
22.6.13	Dynamic Memory Active to Active Command Period register	516	22.7.2.3	Write protected memory areas	528
22.6.14	Dynamic Memory Auto-refresh Period register	517	22.7.3	Pad interface	528
22.6.15	Dynamic Memory Exit Self Refresh register	517	22.7.4	Data buffers	529
22.6.16	Dynamic Memory Active Bank A to Active Bank B Time register	517	22.7.4.1	Write buffers	529
22.6.17	Dynamic Memory Load Mode register to Active Command Time	518	22.7.4.2	Read buffers	529
22.6.18	Static Memory Extended Wait register	518	22.7.5	Using the EMC with SDRAM	530
22.6.19	Dynamic Memory Configuration registers	519	22.7.5.1	SDRAM burst length	530
			22.7.5.2	SDRAM mode register burst length set-up	530
			22.7.5.2.1	Example for setting the SDRAM mode register	532
			22.7.5.3	Self-refresh mode	532
			22.7.6	External static memory interface	533
			22.7.6.1	32 bit wide memory bank connection	533
			22.7.6.2	16 bit wide memory bank connection	534
			22.7.6.3	8 bit wide memory bank connection	535

Chapter 23: LPC18xx USB0 Host/Device/OTG controller

23.1	How to read this chapter	536	23.6.5.2	Host mode	555
23.2	Basic configuration	536	23.6.6	Frame index register (FRINDEX)	556
23.3	Features	536	23.6.6.1	Device mode	556
23.4	Introduction	537	23.6.6.2	Host mode	557
23.4.1	Block diagram	537	23.6.7	Device address (DEVICEADDR - device) and Periodic List Base (PERIODICLISTBASE - host) registers	557
23.4.2	About USB On-The-Go	537	23.6.7.1	Device mode	557
23.4.3	USB acronyms and abbreviations	538	23.6.7.2	Host mode	558
23.4.4	Transmit and receive buffers	538	23.6.8	Endpoint List Address register (ENDPOINTLISTADDR - device) and Asynchronous List Address (ASYNCLISTADDR - host) registers	558
23.4.5	Fixed endpoint configuration	538	23.6.8.1	Device mode	558
23.5	Pin description	539	23.6.8.2	Host mode	559
23.5.1	Requirements for connecting the USB0_VBUS/USB1_VBUS signal	540	23.6.9	TT Control register (TTCTRL)	559
23.6	Register description	540	23.6.9.1	Device mode	559
23.6.1	Use of registers	542	23.6.9.2	Host mode	559
23.6.2	Device/host capability registers	544	23.6.10	Burst Size register (BURSTSIZE)	559
23.6.3	USB Command register (USBCMD)	546	23.6.11	Transfer buffer Fill Tuning register (TXFILLTUNING)	560
23.6.3.1	Device mode	546	23.6.11.1	Device controller	560
23.6.3.2	Host mode	547	23.6.11.2	Host controller	560
23.6.4	USB Status register (USBSTS)	549	23.6.12	BINTERVAL register	561
23.6.4.1	Device mode	550	23.6.13	USB Endpoint NAK register (ENDPTNAK)	562
23.6.4.2	Host mode	552			
23.6.5	USB Interrupt register (USBINTR)	554			
23.6.5.1	Device mode	554			

23.6.13.1	Device mode	562	23.8.3.1	Discovery	588
23.6.13.2	Host mode	562	23.8.3.1.1	Port reset	588
23.6.14	USB Endpoint NAK Enable register (ENDPTNAKEN)	562	23.8.3.1.2	Port speed detection	589
23.6.14.1	Device mode	562	23.9	Device data structures	589
23.6.14.2	Host mode	563	23.9.1	Endpoint queue head (dQH)	590
23.6.15	Port Status and Control register (PORTSC1)	563	23.9.1.1	Endpoint capabilities and characteristics descriptor fields	591
23.6.15.1	Device mode	563	23.9.1.2	Current dTD pointer descriptor fields	592
23.6.15.2	Host mode	566	23.9.1.3	Transfer overlay descriptor fields	593
23.6.16	OTG Status and Control register (OTGSC)	570	23.9.1.4	Set-up buffer descriptor fields	593
23.6.17	USB Mode register (USBMODE)	573	23.9.2	Endpoint transfer descriptor (dTD)	593
23.6.17.1	Device mode	573	23.9.2.1	Determining the number of packets for Isochronous IN endpoints	595
23.6.17.2	Host mode	574	Example 1		595
23.6.18	USB Endpoint Setup Status register (ENDPSETUPSTAT)	575	Example 2		595
23.6.19	USB Endpoint Prime register (ENDPTPRIME)	575	23.10	Device operational model	595
23.6.20	USB Endpoint Flush register (ENDPTFLUSH)	576	23.10.1	Device controller initialization	595
23.6.21	USB Endpoint Status register (ENDPTSTAT)	577	23.10.2	Port state and control	596
23.6.22	USB Endpoint Complete register (ENDPTCOMPLETE)	577	23.10.3	Bus reset	598
23.6.23	USB Endpoint 0 Control register (ENDPTCTRL0)	578	23.10.4	Suspend/resume	599
23.6.24	Endpoint 1 to 5 control registers	579	23.10.4.1	Suspend	599
23.7	Functional description	581	23.10.4.1.1	Operational model	599
23.7.1	OTG core	581	23.10.4.2	Resume	599
23.7.2	Host data structures	581	23.10.5	Managing endpoints	600
23.7.3	Host operational model	581	23.10.5.1	Endpoint initialization	600
23.7.4	ATX_RGEN module	581	23.10.5.2	Stalling	601
23.7.5	ATX transceiver	582	23.10.5.3	Data toggle	601
23.7.6	Modes of operation	582	23.10.5.3.1	Data toggle reset	601
23.7.7	SOF/VF indicator	582	23.10.5.3.2	Data toggle inhibit	601
23.7.7.1	SOF frame length adjust	582	23.10.6	Operational model for packet transfers	602
23.7.8	Hardware assist	583	23.10.6.1	Priming transmit endpoints	602
23.7.8.1	Auto reset	583	23.10.6.2	Priming receive endpoints	603
23.7.8.2	Data pulse	583	23.10.7	Interrupt/bulk endpoint operational model	603
23.7.8.3	B-disconnect to A-connect (Transition to the A-peripheral state)	583	23.10.7.1	Interrupt/bulk endpoint bus response matrix	604
23.8	Deviations from EHCI standard	584	23.10.8	Control endpoint operational model	604
23.8.1	Embedded Transaction Translator function	584	23.10.8.1	Setup phase	604
23.8.1.1	Capability registers	585	23.10.8.1.1	Setup packet handling using setup lockout mechanism	605
23.8.1.2	Operational registers	585	23.10.8.1.2	Setup packet handling using the trip wire mechanism	605
23.8.1.3	Discovery	585	23.10.8.2	Data phase	606
23.8.1.4	Data structures	586	23.10.8.3	Status phase	606
23.8.1.5	Operational model	586	23.10.8.4	Control endpoint bus response matrix	606
23.8.1.5.1	Micro-frame pipeline	586	23.10.9	Isochronous endpoint operational model	607
23.8.1.6	Split state machines	587	TX packet retired		608
23.8.1.7	Asynchronous Transaction scheduling and buffer management	587	RX packet retired		608
23.8.1.8	Periodic Transaction scheduling and buffer management	587	23.10.9.1	Isochronous pipe synchronization	608
23.8.1.9	Multiple Transaction Translators	588	23.10.9.2	Isochronous endpoint bus response matrix	609
23.8.2	Device operation	588	23.10.10	Managing queue heads	609
23.8.2.1	USBMODE register	588	23.10.10.1	Queue head initialization	610
23.8.2.2	Non-Zero register fields	588	23.10.10.2	Operational model for setup transfers	610
23.8.2.3	SOF interrupt	588	23.10.11	Managing transfers with transfer descriptors	611
23.8.3	Deviations from EHCI	588	23.10.11.1	Software link pointers	611
			23.10.11.2	Building a transfer descriptor	611
			23.10.11.3	Executing a transfer descriptor	612
			Linked list is empty		612
			Linked list is not empty		612
			23.10.11.4	Transfer completion	612

25.5.13	_MSC_CBW	669	25.5.26	USBD_API_INIT_PARAM	675
25.5.14	_MSC_CS_W	670	25.5.27	USBD_CDC_API	677
25.5.15	_REQUEST_TYPE	670	25.5.28	USBD_CDC_INIT_PARAM	678
25.5.16	_USB_COMMON_DESCRIPTOR	670	25.5.29	USBD_CORE_API	687
25.5.17	_USB_CORE_DESCS_T	670	25.5.30	USBD_DFU_API	690
25.5.18	_USB_DEVICE_QUALIFIER_DESCRIPTOR	671	25.5.31	USBD_DFU_INIT_PARAM	691
25.5.19	_USB_DFU_FUNC_DESCRIPTOR	671	25.5.32	USBD_HID_API	693
25.5.20	_USB_INTERFACE_DESCRIPTOR	672	25.5.33	USBD_HID_INIT_PARAM	694
25.5.21	_USB_OTHER_SPEED_CONFIGURATION	672	25.5.34	USBD_HW_API	700
25.5.22	_USB_SETUP_PACKET	673	25.5.35	USBD_MSC_API	708
25.5.23	_USB_STRING_DESCRIPTOR	673	25.5.36	USBD_MSC_INIT_PARAM	709
25.5.24	_WB_T	674	25.5.37	USB API error codes	713
25.5.25	USBD_API	674			

Chapter 26: LPC18xx Ethernet

26.1	How to read this chapter	714	26.6.36	DMA Receive interrupt watchdog timer register	751
26.2	Basic configuration	714	26.6.37	DMA Current host transmit descriptor register	752
26.3	Features	714	26.6.38	DMA Current host receive descriptor register	752
26.4	General description	715	26.6.39	DMA Current host transmit buffer address register	752
26.5	Pin description	716	26.6.40	DMA Current host receive buffer address register	753
26.6	Register description	717	26.7	Functional description	753
26.6.1	MAC Configuration register	718	26.7.1	Hash filter	753
26.6.2	MAC Frame filter register	721	26.7.1.1	Example for a unicast MAC address	753
26.6.3	MAC Hash table high register	722	26.7.1.2	Example for a multicast MAC address	754
26.6.4	MAC Hash table low register	723	26.7.2	Power management block	754
26.6.5	MAC MII Address register	723	26.7.2.1	Remote wake-up frame registers	754
26.6.6	MAC MII Data register	725		Filter i byte mask	755
26.6.7	MAC Flow control register	725		Filter i command	755
26.6.8	MAC VLAN tag register	727		Filter i offset	755
26.6.9	MAC Debug register	727		Filter i CRC-16	755
26.6.10	MAC Remote wake-up frame filter register	729	26.7.2.2	Remote wake-up detection	755
26.6.11	MAC PMT control and status register	729	26.7.2.3	Magic packet detection	756
26.6.12	MAC Interrupt status register	730	26.7.2.4	System considerations during power-down	757
26.6.13	MAC Interrupt mask register	731	26.7.3	DMA arbiter functions	757
26.6.14	MAC Address 0 high register	731	26.7.4	IEEE 1588-2002 timestamps	758
26.6.15	MAC Address 0 low register	732	26.7.4.1	Reference timing source	760
26.6.16	MAC IEEE1588 time stamp control register	732	26.7.4.2	System time register module	760
26.6.17	Sub-second increment register	734	26.7.4.3	Transmit path functions	762
26.6.18	System time seconds register	735	26.7.4.4	Receive path functions	763
26.6.19	System time nanoseconds register	735	26.7.4.5	Timestamp error margin	763
26.6.20	System time seconds update register	736	26.7.4.6	Frequency range of the reference timing clock	763
26.6.21	System time nanoseconds update register	736			
26.6.22	Time stamp addend register	737	26.7.5	IEEE 1588-2008 advanced timestamps	764
26.6.23	Target time seconds register	737	26.7.5.1	Peer-to-Peer PTP Transparent Clock (P2P TC) Message Support	764
26.6.24	Target time nanoseconds register	738		Clock types	766
26.6.25	System time higher words seconds register	738	26.7.5.2.1	Ordinary clock	766
26.6.26	Time stamp status register	738	26.7.5.2.2	Boundary clock	766
26.6.27	DMA Bus mode register	739	26.7.5.2.3	End-to-end transparent clock	766
26.6.28	DMA Transmit poll demand register	741	26.7.5.2.4	Peer-to-peer transparent clock support	767
26.6.29	DMA Receive poll demand register	742	26.7.5.3	PTP processing and control	767
26.6.30	DMA Receive descriptor list address register	742	26.7.5.3.1	PTP frames over IPv4	768
26.6.31	DMA Transmit descriptor list address register	742	26.7.5.3.2	PTP Frames Over IPv6	769
26.6.32	DMA Status register	743			
26.6.33	DMA Operation mode register	746			
26.6.34	DMA Interrupt enable register	748			
26.6.35	DMA Missed frame and buffer overflow counter register	751			

26.7.5.3.3 PTP frames over ethernet	770	26.7.6.2.1 TxDMA operation: Default (non-OSF) mode	776
26.7.5.4 Reference timing source	771	26.7.6.2.2 TxDMA operation: OSF mode	778
26.7.5.4.1 48-bit seconds field	771	26.7.6.2.3 Transmit frame processing	781
26.7.5.5 Transmit path functions	771	26.7.6.2.4 Transmit polling suspended	781
26.7.5.6 Receive path functions	771	26.7.6.2.5 Reception	782
26.7.6 DMA controller description	772	26.7.6.2.6 Receive descriptor acquisition	784
26.7.6.1 Initialization	774	26.7.6.2.7 Receive frame processing	784
26.7.6.1.1 Host bus burst access	774	26.7.6.2.8 Receive process suspended	784
26.7.6.1.2 Host data buffer alignment	775	26.7.6.2.9 Interrupts	785
Example: Buffer read	775	26.7.6.2.10 Error response to DMA	786
Example: Buffer write	775	26.7.6.3 Ethernet descriptors	786
26.7.6.1.3 Buffer size calculations	775	26.7.6.3.1 Transmit descriptor	786
26.7.6.1.4 DMA arbiter	776	26.7.6.3.2 Receive descriptor	791
26.7.6.2 Transmission	776		

Chapter 27: LPC18xx LCD

27.1 How to read this chapter	798	27.6.20 Cursor XY Position register	819
27.2 Basic configuration	798	27.6.21 Cursor Clip Position register	819
27.3 Features	798	27.6.22 Cursor Interrupt Mask register	820
27.4 General description	799	27.6.23 Cursor Interrupt Clear register	820
27.4.1 Programmable parameters	800	27.6.24 Cursor Raw Interrupt Status register	821
27.4.2 Hardware cursor support	801	27.6.25 Cursor Masked Interrupt Status register	821
27.4.3 Types of LCD panels supported	801	27.7 Functional description	821
27.4.3.1 TFT panels	801	27.7.1 AHB interfaces	821
27.4.3.2 Color STN panels	802	27.7.1.1 AMBA AHB slave interface	821
27.4.3.3 Monochrome STN panels	802	27.7.1.2 AMBA AHB master interface	822
27.5 Pin description	802	27.7.2 Dual DMA FIFOs and associated control logic	822
27.5.1 Signal usage	803	27.7.3 Pixel serializer	822
27.5.1.1 Signals used for single panel STN displays	803	27.7.4 RAM palette	826
27.5.1.2 Signals used for dual panel STN displays	803	27.7.5 Hardware cursor	828
27.5.1.3 Signals used for TFT displays	804	27.7.5.1 Cursor operation	828
27.6 Register description	804	27.7.5.2 Cursor sizes	829
27.6.1 Horizontal Timing register	805	27.7.5.3 Cursor movement	829
27.6.1.1 Horizontal timing restrictions	806	27.7.5.4 Cursor XY positioning	829
27.6.2 Vertical Timing register	807	27.7.5.5 Cursor clipping	830
27.6.3 Clock and Signal Polarity register	807	27.7.5.6 Cursor image format	831
27.6.4 Line End Control register	809	27.7.6 Gray scaler	833
27.6.5 Upper Panel Frame Base Address register	810	27.7.7 Upper and lower panel formatters	833
27.6.6 Lower Panel Frame Base Address register	810	27.7.8 Panel clock generator	834
27.6.7 LCD Control register	811	27.7.9 Timing controller	834
27.6.8 Interrupt Mask register	813	27.7.10 STN and TFT data select	834
27.6.9 Raw Interrupt Status register	813	27.7.10.1 STN displays	834
27.6.10 Masked Interrupt Status register	814	27.7.10.2 TFT displays	834
27.6.11 Interrupt Clear register	814	27.7.11 Interrupt generation	834
27.6.12 Upper Panel Current Address register	815	27.7.11.1 Master bus error interrupt	835
27.6.13 Lower Panel Current Address register	815	27.7.11.2 Vertical compare interrupt	835
27.6.14 Color Palette registers	815	27.7.11.2.1 Next base address update interrupt	835
27.6.15 Cursor Image registers	816	27.7.11.2.2 FIFO underflow interrupt	835
27.6.16 Cursor Control register	817	27.7.12 LCD power-up and power-down sequence	835
27.6.17 Cursor Configuration register	817	27.8 LCD timing diagrams	838
27.6.18 Cursor Palette register 0	818	27.9 LCD panel signal usage	840
27.6.19 Cursor Palette register 1	818		

Chapter 28: LPC18xx State Configurable Timer (SCT)

28.1 How to read this chapter	844	28.3 Features	844
28.2 Basic configuration	844	28.4 General description	845

28.5	Pin description	846	28.6.22	SCT capture control registers 0 to 15 (REGMODEn bit = 1)	867
28.6	Register description	848	28.6.23	SCT event state mask registers 0 to 15	867
28.6.1	SCT configuration register	852	28.6.24	SCT event control registers 0 to 15	867
28.6.2	SCT control register	854	28.6.25	SCT output set registers 0 to 15	869
28.6.3	SCT limit register	855	28.6.26	SCT output clear registers 0 to 15	869
28.6.4	SCT halt condition register	855	28.7	Functional description	870
28.6.5	SCT stop condition register	856	28.7.1	Match logic	870
28.6.6	SCT start condition register	856	28.7.2	Capture logic	870
28.6.7	SCT counter register	856	28.7.3	Event selection	870
28.6.8	SCT state register	857	28.7.4	Output generation	871
28.6.9	SCT input register	858	28.7.5	Interrupt generation	871
28.6.10	SCT match/capture registers mode register	858	28.7.6	Clearing the prescaler	872
28.6.11	SCT output register	859	28.7.7	Match vs. I/O events	872
28.6.12	SCT bidirectional output control register	859	28.7.8	DMA operation	872
28.6.13	SCT conflict resolution register	861	28.7.9	Alternate addressing for match/capture registers 873	
28.6.14	SCT DMA request 0 and 1 registers	863	28.7.10	SCT operation	875
28.6.15	SCT flag enable register	864	28.7.10.1	Configure the SCT	875
28.6.16	SCT event flag register	864	28.7.10.1.1	Configure the counter	875
28.6.17	SCT conflict enable register	865	28.7.10.1.2	Configure the match and capture registers	875
28.6.18	SCT conflict flag register	865	28.7.10.1.3	Configure events and event responses	876
28.6.19	SCT match registers 0 to 15 (REGMODEn bit = 0) 865		28.7.10.1.4	Configure multiple states	877
28.6.20	SCT capture registers 0 to 15 (REGMODEn bit = 1)	866	28.7.10.1.5	Miscellaneous options	877
28.6.21	SCT match reload registers 0 to 15 (REGMODEn bit = 0)	866	28.7.10.2	Operate the SCT	877
			28.7.10.3	Configure the SCT without using states	878

Chapter 29: LPC18xx State Configurable Timer (SCT) with dither engine

29.1	How to read this chapter	879	29.3.19	SCT conflict flag register	898
29.2	Features	879	29.3.20	SCT match registers 0 to 15 (REGMODEn bit = 0) 899	
29.3	Register description	880	29.3.21	SCT fractional match registers 0 to 5	899
29.3.1	SCT configuration register	884	29.3.22	SCT capture registers 0 to 15 (REGMODEn bit = 1)	900
29.3.2	SCT control register	886	29.3.23	SCT match reload registers 0 to 15 (REGMODEn bit = 0)	901
29.3.3	SCT limit register	887	29.3.24	SCT fractional match reload registers 0 to 5	901
29.3.4	SCT halt condition register	888	29.3.25	SCT capture control registers 0 to 15 (REGMODEn bit = 1)	901
29.3.5	SCT stop condition register	888	29.3.26	SCT event state mask registers 0 to 15	902
29.3.6	SCT start condition register	888	29.3.27	SCT event control registers 0 to 15	902
29.3.7	SCT dither condition register	889	29.3.28	SCT output set registers 0 to 15	904
29.3.8	SCT counter register	890	29.3.29	SCT output clear registers 0 to 15	904
29.3.9	SCT state register	890	29.4	Functional description	904
29.3.10	SCT input register	891	29.4.1	Fractional matches	904
29.3.11	SCT match/capture registers mode register	892	29.4.1.1	Dithering	905
29.3.12	SCT output register	892	29.4.2	Alternate addressing for match/capture registers 906	
29.3.13	SCT bidirectional output control register	893	29.4.3	SCT Example	906
29.3.14	SCT conflict resolution register	895			
29.3.15	SCT DMA request 0 and 1 registers	897			
29.3.16	SCT flag enable register	897			
29.3.17	SCT event flag register	898			
29.3.18	SCT conflict enable register	898			

Chapter 30: LPC18xx Timer0/1/2/3

30.1	How to read this chapter	910	30.5	Pin description	913
30.2	Basic configuration	910	30.6	Register description	916
30.3	Features	910	30.6.1	Timer interrupt registers	917
30.4	General description	911	30.6.2	Timer control registers	918
30.4.1	Architecture	911	30.6.3	Timer counter registers	918

30.6.4	Timer prescale registers	918	30.6.10	Timer external match registers	923
30.6.5	Timer prescale counter registers	919	30.6.11	Timer count control registers	924
30.6.6	Timer match control registers	919	30.7	Functional description	925
30.6.7	Timer match registers (MR0 - MR3)	920	30.7.1	Example timer operation	925
30.6.8	Timer capture control registers	921	30.7.2	DMA operation	926
30.6.9	Timer capture registers (CR0 - CR3)	922			

Chapter 31: LPC18xx Motor Control PWM (MOTCONPWM)

31.1	How to read this chapter	927	31.7.9	MCPWM Interrupt registers	940
31.2	Basic configuration	927	7.9.1	MCPWM Interrupt Enable read address	941
31.3	Introduction	927	31.7.9.2	MCPWM Interrupt Enable set address	942
31.4	Features	927	31.7.9.3	MCPWM Interrupt Enable clear address	942
31.5	General description	927	31.7.10	MCPWM Count Control register	943
31.5.1	Block Diagram	929	31.7.10.1	MCPWM Count Control read address	943
31.6	Pin description	929	31.7.10.2	MCPWM Count Control set address	945
31.7	Register description	930	31.7.10.3	MCPWM Count Control clear address	946
31.7.1	MCPWM Control register	931	31.7.11	MCPWM Interrupt flag registers	947
31.7.1.1	MCPWM Control read address	931	31.7.11.1	MCPWM Interrupt Flags read address	947
31.7.1.2	MCPWM Control set address	933	31.7.11.2	MCPWM Interrupt Flags set address	949
31.7.1.3	MCPWM Control clear address	933	31.7.11.3	MCPWM Interrupt Flags clear address	950
31.7.2	PWM Capture Control register	934	31.7.12	MCPWM Capture clear address	950
31.7.2.1	MCPWM Capture Control read address	934	31.8	Functional description	951
31.7.2.2	MCPWM Capture Control set address	935	31.8.1	Pulse-width modulation	951
31.7.2.3	MCPWM Capture control clear address	936		Edge-aligned PWM without dead-time	951
31.7.3	MCPWM Timer/Counter 0-2 registers	937		Center-aligned PWM without dead-time	951
31.7.4	MCPWM Limit 0-2 registers	937		Dead-time counter	952
31.7.5	MCPWM Match 0-2 registers	938	31.8.2	Shadow registers and simultaneous updates	953
31.7.5.1	Match register in Edge-Aligned mode	938	31.8.3	Fast Abort (ABORT)	953
31.7.5.2	Match register in Center-Aligned mode	939	31.8.4	Capture events	953
31.7.5.3	0 and 100% duty cycle	939	31.8.5	External event counting (Counter mode)	954
31.7.6	MCPWM Dead-time register	939	31.8.6	Three-phase DC mode	954
31.7.7	MCPWM Communication Pattern register	940	31.8.7	Three phase AC mode	955
31.7.8	MCPWM Capture read addresses	940	31.8.8	Interrupts	956

Chapter 32: LPC18xx Quadrature Encoder Interface (QEI)

32.1	How to read this chapter	957	32.6.2.10	QEI Velocity register	965
32.2	Basic configuration	957	32.6.2.11	QEI Velocity Capture register	966
32.3	Features	957	32.6.2.12	QEI Velocity Compare register	966
32.4	Introduction	958	32.6.2.13	QEI Digital filter on phase A input register	966
32.5	Pin description	960	32.6.2.14	QEI Digital filter on phase B input register	966
32.6	Register description	960	32.6.2.15	QEI Digital filter on index input register	966
32.6.1	Control registers	962	32.6.2.16	QEI Index acceptance window register	967
32.6.1.1	QEI Control register	962	32.6.2.17	QEI Index Compare register 1	967
32.6.1.2	QEI Status register	962	32.6.2.18	QEI Index Compare register 2	967
32.6.1.3	QEI Configuration register	962	32.6.3	Interrupt registers	968
32.6.2	Position, index and timer registers	964	32.6.3.1	QEI Interrupt Enable Clear register	968
32.6.2.1	QEI Position register	964	32.6.3.2	QEI Interrupt Enable Set register	968
32.6.2.2	QEI Maximum Position register	964	32.6.3.3	QEI Interrupt Status register	969
32.6.2.3	QEI Position Compare register 0	964	32.6.3.4	QEI Interrupt Enable register	970
32.6.2.4	QEI Position Compare register 1	964	32.6.3.5	QEI Interrupt Status Clear register	970
32.6.2.5	QEI Position Compare register 2	964	32.6.3.6	QEI Interrupt Status Set register	971
32.6.2.6	QEI Index Count register	965	32.7	Functional description	972
32.6.2.7	QEI Index Compare register 0	965	32.7.1	Input signals	972
32.6.2.8	QEI Timer Reload register	965	32.7.1.1	Quadrature input signals	972
32.6.2.9	QEI Timer register	965	32.7.1.2	Digital input filtering	973
			32.7.2	Position capture	973

32.7.3	Velocity capture	973	32.7.4	Velocity compare	974
--------	------------------	-----	--------	------------------	-----

Chapter 33: LPC18xx Repetitive Interrupt Timer (RIT)

33.1	How to read this chapter	975	33.5.1	RI Compare Value register	977
33.2	Basic configuration	975	33.5.2	RI Mask register	977
33.3	Features	975	33.5.3	RI Control register	977
33.4	General description	975	33.5.4	RI Counter register	978
33.5	Register description	976	33.6	RI timer operation	978

Chapter 34: LPC18xx Alarm timer

34.1	How to read this chapter	979	34.4.3	Interrupt clear enable register	980
34.2	Basic configuration	979	34.4.4	Interrupt set enable register	981
34.3	General description	979	34.4.5	Interrupt status register	981
34.4	Register description	980	34.4.6	Interrupt enable register	981
34.4.1	Downcounter register	980	34.4.7	Clear status register	981
34.4.2	Preset value register	980	34.4.8	Set status register	981

Chapter 35: LPC18xx Windowed Watchdog timer (WWDT)

35.1	How to read this chapter	982	35.7	Register description	984
35.2	Basic configuration	982	35.7.1	Watchdog mode register	984
35.3	Features	982	35.7.2	Watchdog timer constant register	986
35.4	Applications	983	35.7.3	Watchdog feed register	986
35.5	Description	983	35.7.4	Watchdog timer value register	987
35.5.1	WWDT behavior in Debug mode	983	35.7.5	Watchdog timer warning interrupt register	987
35.5.2	WWDT behavior in the power-down modes	984	35.7.6	Watchdog timer window register	987
35.6	Clocking	984	35.8	Block diagram	988
			35.9	Watchdog timing examples	988

Chapter 36: LPC18xx Real-Time Clock (RTC)

36.1	How to read this chapter	990	36.6.5.2	Consolidated Time Register 1	995
36.2	Basic configuration	990	36.6.5.3	Consolidated Time Register 2	996
36.3	Features	990	36.6.6	Time Counter Group	996
36.4	General description	991	36.6.6.1	Leap year calculation	998
36.5	Pin description	991	36.6.6.2	Calibration register	998
36.6	Register description	992	36.6.7	Alarm register group	999
36.6.1	Interrupt Location Register	993	36.7	Functional description	1001
36.6.2	Clock Control Register	993	36.7.1	Register read procedure	1001
36.6.3	Counter Increment Interrupt Register	994	36.7.2	Calibration procedure	1001
36.6.4	Alarm Mask Register	994		Backward calibration	1001
36.6.5	Consolidated time registers	995		Forward calibration	1002
36.6.5.1	Consolidated Time Register 0	995			

Chapter 37: LPC18xx Event monitor/recorder

37.1	How to read this chapter	1003	37.7.2	Event Monitor/Recorder Status Register	1009
37.2	Basic configuration	1003	37.7.3	Event Monitor/Recorder Counters Register	1010
37.3	Features	1003	37.7.4	Event Monitor/Recorder First Stamp Registers	1010
37.4	Applications	1003			
37.5	General description	1004	37.7.5	Event Monitor/Recorder Last Stamp Registers	1010
37.6	Pin description	1006			
37.7	Register description	1006			
37.7.1	Event Monitor/Recorder Control Register	1007			

Chapter 38: LPC18xx USART0_2_3

38.1	How to read this chapter	1012		
38.2	Basic configuration	1012		
38.3	Features	1012		
38.4	General description	1013		
38.5	Pin description	1015		
38.6	Register description	1015		
38.6.1	USART Receiver Buffer Register	1018	38.6.19	USART Synchronous mode control register 1034
38.6.2	USART Transmitter Holding Register	1018	38.6.20	USART Transmit Enable Register 1036
38.6.3	USART Divisor Latch LSB and MSB Registers	1018	38.7	Functional description 1036
38.6.4	USART Interrupt Enable Register	1019	38.7.1	Auto-baud 1036
38.6.5	USART Interrupt Identification Register	1020	38.7.2	Auto-baud modes 1037
38.6.6	USART FIFO Control Register	1022	38.7.3	Baud rate calculation in asynchronous mode 1039
38.6.6.1	DMA Operation	1023	38.7.3.1	Example 1: USART_PCLK = 14.7456 MHz, BR = 9600 1041
	USART receiver DMA	1023	38.7.3.2	Example 2: USART_PCLK = 12 MHz, BR = 115200 1041
	USART transmitter DMA	1023	38.7.4	RS-485/EIA-485 modes of operation 1041
38.6.7	USART Line Control Register	1024		RS-485/EIA-485 Normal Multidrop Mode (NMM) 1042
38.6.8	USART Line Status Register	1024		RS-485/EIA-485 Auto Address Detection (AAD) mode 1042
38.6.9	USART Scratch Pad Register	1026		RS-485/EIA-485 Auto Direction Control 1042
38.6.10	USART Auto-baud Control Register	1026		RS485/EIA-485 driver delay time 1043
38.6.11	IrDA Control Register (USART3)	1027	38.7.5	Synchronous mode 1043
38.6.12	USART Fractional Divider Register	1028	38.7.5.1	USART clock in synchronous mode 1043
38.6.13	USART Oversampling Register	1029	38.7.5.2	Synchronous slave mode 1044
38.6.14	USART Half-duplex enable register	1030		Reception 1044
38.6.15	USART Smart card interface control register	1031		Transmission 1044
38.6.16	USART RS485 Control register	1032	38.7.5.3	Synchronous master mode 1045
38.6.17	USART RS485 Address Match register	1033	38.7.6	Smart card mode 1045
38.6.18	USART RS485 Delay value register	1034	38.7.6.1	Smart card set-up procedure 1046

Chapter 39: LPC18xx UART1

39.1	How to read this chapter	1047	39.6.7	UART1 Line Control Register 1057
39.2	Basic configuration	1047	39.6.8	UART1 Modem Control Register 1058
39.3	Features	1047	39.6.9	UART1 Line Status Register 1059
39.4	General description	1047	39.6.10	UART1 Modem Status Register 1061
39.5	Pin description	1050	39.6.11	UART1 Scratch Pad Register 1061
39.6	Register description	1051	39.6.12	UART1 Auto-baud Control Register 1061
39.6.1	UART1 Receiver Buffer Register (when DLAB = 0)	1052	39.6.13	UART1 Fractional Divider Register 1062
39.6.2	UART1 Transmitter Holding Register (when DLAB = 0)	1052	39.6.14	UART1 RS485 Control register 1063
39.6.3	UART1 Divisor Latch LSB and MSB Registers (when DLAB = 1)	1052	39.6.15	UART1 RS-485 Address Match register 1064
39.6.4	UART1 Interrupt Enable Register (when DLAB = 0)	1053	39.6.16	UART1 RS-485 Delay value register 1064
39.6.5	UART1 Interrupt Identification Register	1054	39.6.17	UART1 Transmit Enable Register 1064
39.6.6	UART1 FIFO Control Register	1056	39.7	Functional description 1065
39.6.6.1	DMA Operation	1057	39.7.1	Auto-flow control 1065
	UART receiver DMA	1057	39.7.1.1	Auto-RTS 1065
	UART transmitter DMA	1057	39.7.1.2	Auto-CTS 1066
			39.7.2	Auto-baud 1067
			39.7.3	Auto-baud modes 1067
			39.7.4	Baud rate calculation 1067
			39.7.5	RS-485/EIA-485 modes of operation 1067

Chapter 40: LPC18xx SSP0/1

40.1	How to read this chapter	1068	40.2	Basic configuration 1068
-------------	---	-------------	-------------	--

40.3	Features	1068	40.7	Functional description	1076
40.4	General description	1068	40.7.1	Texas Instruments synchronous serial frame format	1076
40.5	Pin description	1069	40.7.2	SPI frame format	1077
40.6	Register description	1069	40.7.2.1	Clock Polarity (CPOL) and Phase (CPHA) control	1077
40.6.1	SSP Control Register 0	1070	40.7.2.2	SPI format with CPOL=0,CPHA=0	1077
40.6.2	SSP Control Register 1	1071	40.7.2.3	SPI format with CPOL=0,CPHA=1	1078
40.6.3	SSP Data Register	1072	40.7.2.4	SPI format with CPOL = 1,CPHA = 0	1079
40.6.4	SSP Status Register	1073	40.7.2.5	SPI format with CPOL = 1,CPHA = 1	1080
40.6.5	SSP Clock Prescale Register	1073	40.7.3	National Semiconductor Microwire frame format	1081
40.6.6	SSP Interrupt Mask Set/Clear Register	1073	40.7.3.1	Setup and hold time requirements on CS with respect to SK in Microwire mode	1082
40.6.7	SSP Raw Interrupt Status Register	1074			
40.6.8	SSP Masked Interrupt Status Register	1074			
40.6.9	SSP Interrupt Clear Register	1075			
40.6.10	SSP DMA Control Register	1075			

Chapter 41: LPC18xx I2S interface

41.1	How to read this chapter	1083	41.7.1	I2S transmit and receive interfaces	1096
41.2	Basic configuration	1083	41.7.2	I2S operating modes	1097
41.3	Features	1083	41.7.2.1	I2S Transmitter modes	1099
41.4	General description	1084	41.7.2.1.1	Typical transmitter master mode (PCLK - no MCLK output)	1099
41.4.1	I2S connection schemes	1084	41.7.2.1.2	Transmitter master mode (PCLK), with MCLK output	1100
41.4.2	I2S connections to the GIMA	1085	41.7.2.1.3	Transmitter master mode, sharing RX_MCLK	1101
41.5	Pin description	1086	41.7.2.1.4	Typical Transmitter slave mode	1102
41.6	Register description	1088	41.7.2.1.5	4-Wire Transmitter mode	1103
41.6.1	I2S Digital Audio Output register	1089	41.7.2.1.6	Transmitter master mode (BASE_AUDIO_CLK)	1104
41.6.2	I2S Digital Audio Input register	1090	41.7.2.1.7	Transmitter master mode (External MCLK)	1105
41.6.3	I2S Transmit FIFO register	1090	41.7.2.2	I2S Receiver modes	1106
41.6.4	Receive FIFO register	1090	41.7.2.2.1	Typical Receiver master mode (PCLK - no MCLK output)	1106
41.6.5	I2S Status Feedback register	1091	41.7.2.2.2	Receiver master mode (PCLK), with MCLK output	1107
41.6.6	I2S DMA Configuration Register 1	1091	41.7.2.2.3	Receiver master mode, sharing TX_MCLK	1108
41.6.7	I2S DMA Configuration Register 2	1092	41.7.2.2.4	Typical Receiver slave mode	1109
41.6.8	I2S Interrupt Request Control register	1092	41.7.2.2.5	4-Wire Receiver mode	1110
41.6.9	I2S Transmit Clock Rate register	1093	41.7.2.2.6	Receiver master mode (BASE_AUDIO_CLK)	1111
41.6.9.1	Notes on fractional rate generators	1093	41.7.2.2.7	Receiver master mode (External MCLK)	1112
41.6.10	I2S Receive Clock Rate register	1094	41.7.3	FIFO controller	1112
41.6.11	I2S Transmit Clock Bit Rate register	1094			
41.6.12	I2S Receive Clock Bit Rate register	1095			
41.6.13	I2S Transmit Mode Control register	1095			
41.6.14	I2S Receive Mode Control register	1095			
41.7	Functional description	1096			

Chapter 42: LPC18xx I2C-bus interface

42.1	How to read this chapter	1115	42.7.4	I ² C Slave Address register 0	1122
42.2	Basic configuration	1115	42.7.5	I ² C SCL HIGH and LOW duty cycle registers	1123
42.3	Features	1115	42.7.5.1	Selecting the appropriate I ² C data rate and duty cycle	1123
42.4	Applications	1116	42.7.6	I ² C Control Clear register	1124
42.5	General description	1116	42.7.7	I ² C Monitor mode control register	1124
42.5.1	I ² C Fast-mode Plus	1117	42.7.7.1	Interrupt in Monitor mode	1125
42.6	Pin description	1117	42.7.7.2	Loss of arbitration in Monitor mode	1126
42.7	Register description	1117	42.7.8	I ² C Slave Address registers 1 to 3	1126
42.7.1	I ² C Control Set register	1120	42.7.9	I ² C Data buffer register	1127
42.7.2	I ² C Status register	1122	42.7.10	I ² C Mask registers	1127
42.7.3	I ² C Data register	1122			

42.8	I²C operating modes	1128	42.11	Software example	1153
42.8.1	Master Transmitter mode	1128	42.11.1	Initialization routine	1153
42.8.2	Master Receiver mode	1129	42.11.2	Start Master Transmit function	1153
42.8.3	Slave Receiver mode	1130	42.11.3	Start Master Receive function	1154
42.8.4	Slave Transmitter mode	1131	42.11.4	I ² C interrupt routine	1154
42.9	I²C implementation and operation	1131	42.11.5	Non mode specific states	1154
42.9.1	Input filters and output stages	1132	42.11.5.1	State: 0x00	1154
42.9.2	Address Registers, ADDR0 to ADDR3	1133	42.11.5.2	Master States	1154
42.9.3	Address mask registers, MASK0 to MASK3	1133	42.11.5.3	State: 0x08	1154
42.9.4	Comparator	1133	42.11.5.4	State: 0x10	1155
42.9.5	Shift register, DAT	1133	42.11.6	Master Transmitter states	1155
42.9.6	Arbitration and synchronization logic	1133	42.11.6.1	State: 0x18	1155
42.9.7	Serial clock generator	1134	42.11.6.2	State: 0x20	1155
42.9.8	Timing and control	1135	42.11.6.3	State: 0x28	1155
42.9.9	Control register, CONSET and CONCLR	1135	42.11.6.4	State: 0x30	1156
42.9.10	Status decoder and status register	1135	42.11.6.5	State: 0x38	1156
42.10	Details of I²C operating modes	1135	42.11.7	Master Receive states	1156
42.10.1	Master Transmitter mode	1136	42.11.7.1	State: 0x40	1156
42.10.2	Master Receiver mode	1140	42.11.7.2	State: 0x48	1156
42.10.3	Slave Receiver mode	1143	42.11.7.3	State: 0x50	1156
42.10.4	Slave Transmitter mode	1147	42.11.7.4	State: 0x58	1157
42.10.5	Miscellaneous states	1149	42.11.8	Slave Receiver states	1157
42.10.5.1	STAT = 0xF8	1149	42.11.8.1	State: 0x60	1157
42.10.5.2	STAT = 0x00	1149	42.11.8.2	State: 0x68	1157
42.10.6	Some special cases	1150	42.11.8.3	State: 0x70	1157
42.10.6.1	Simultaneous Repeated START conditions from two masters	1150	42.11.8.4	State: 0x78	1158
42.10.6.2	Data transfer after loss of arbitration	1151	42.11.8.5	State: 0x80	1158
42.10.6.3	Forced access to the I ² C-bus	1151	42.11.8.6	State: 0x88	1158
42.10.6.4	I ² C-bus obstructed by a LOW level on SCL or SDA	1152	42.11.8.7	State: 0x90	1158
42.10.6.5	Bus error	1152	42.11.8.8	State: 0x98	1159
42.10.7	I ² C state service routines	1152	42.11.8.9	State: 0xA0	1159
42.10.8	Initialization	1153	42.11.9	Slave Transmitter states	1159
42.10.9	I ² C interrupt service	1153	42.11.9.1	State: 0xA8	1159
42.10.10	The state service routines	1153	42.11.9.2	State: 0xB0	1159
42.10.11	Adapting state services to an application	1153	42.11.9.3	State: 0xB8	1159
			42.11.9.4	State: 0xC0	1160
			42.11.9.5	State: 0xC8	1160

Chapter 43: LPC18xx C_CAN

43.1	How to read this chapter	1161	43.6.1.2	CAN status register	1169
43.2	Basic configuration	1161	43.6.1.3	CAN error counter	1170
43.3	Features	1161	43.6.1.4	CAN bit timing register	1171
43.4	General description	1162	43.6.1.5	CAN interrupt register	1171
43.5	Pin description	1163	43.6.1.6	CAN test register	1172
43.6	Register description	1164	43.6.1.7	CAN baud rate prescaler extension register	1173
	Register values at reset	1164	43.6.2	Message interface registers	1173
43.6.1	CAN protocol registers	1167	43.6.2.1	Message objects	1175
43.6.1.1	CAN control register	1167	43.6.2.2	CAN message interface command request registers	1175

continued >>

43.6.2.3	CAN message interface command mask registers 1176	43.7.2.1	Software initialization	1193
	Transfer direction Write	43.7.2.2	CAN message transfer.	1194
	Transfer direction Read	43.7.2.3	Disabled Automatic Retransmission (DAR).	1194
43.6.2.4	IF1 and IF2 message buffer registers.	43.7.2.4	Test modes.	1195
43.6.2.4.1	CAN message interface command mask 1 registers	43.7.2.4.1	Silent mode	1195
43.6.2.4.2	CAN message interface command mask 2 registers	43.7.2.4.2	Loop-back mode	1196
43.6.2.4.3	CAN message interface command arbitration 1 registers	43.7.2.4.3	Loop-back mode combined with Silent mode	1196
43.6.2.4.4	CAN message interface command arbitration 2 registers	43.7.2.4.4	Basic mode	1196
43.6.2.4.5	CAN message interface message control registers	43.7.2.4.5	Software control of pin CAN_TD	1197
43.6.2.4.6	CAN message interface data A1 registers	43.7.3	CAN message handler	1198
43.6.2.4.7	CAN message interface data A2 registers	43.7.3.1	Management of message objects	1198
43.6.2.4.8	CAN message interface data B1 registers	43.7.3.2	Data Transfer between IFx Registers and the Message RAM	1199
43.6.2.4.9	CAN message interface data B2 registers	43.7.3.3	Transmission of messages between the shift registers in the CAN core and the Message buffer 1199	
43.6.3	Message handler registers	43.7.3.4	Acceptance filtering of received messages	1200
43.6.3.1	CAN transmission request 1 register	43.7.3.4.1	Reception of a data frame	1200
43.6.3.2	CAN transmission request 2 register	43.7.3.4.2	Reception of a remote frame	1200
43.6.3.3	CAN new data 1 register.	43.7.3.5	Receive/transmit priority	1201
43.6.3.4	CAN new data 2 register	43.7.3.6	Configuration of a transmit object	1201
43.6.3.5	CAN interrupt pending 1 register	43.7.3.7	Updating a transmit object	1201
43.6.3.6	CAN interrupt pending 2 register	43.7.3.8	Configuration of a receive object	1202
43.6.3.7	CAN message valid 1 register	43.7.3.9	Handling of received messages.	1202
43.6.3.8	CAN message valid 2 register	43.7.3.10	Configuration of a FIFO buffer	1203
43.6.4	CAN timing register	43.7.3.10.1	Reception of messages with FIFO buffers	1203
43.6.4.1	CAN clock divider register	43.7.3.10.2	Reading from a FIFO buffer	1203
43.7	Functional description	43.7.4	Interrupt handling	1204
43.7.1	C_CAN controller state after reset	43.7.5	Bit timing	1205
43.7.2	C_CAN operating modes	43.7.5.1	Bit time and bit rate	1206
		43.7.5.1.1	Calculating the C_CAN bit rate	1207

Chapter 44: LPC18xx 10-bit ADC0/1

44.1	How to read this chapter.	1208	44.6.3	A/D Interrupt Enable register	1215
44.2	Basic configuration	1209	44.6.4	A/D Data Registers	1215
44.3	Features	1210	44.6.5	A/D Status register.	1216
44.4	General description.	1210	44.7	Operation	1216
44.5	Pin description.	1210	44.7.1	Hardware-triggered conversion	1216
44.6	Register description	1211	44.7.2	Interrupts	1216
44.6.1	A/D Control register	1212	44.7.3	DMA control	1217
44.6.2	A/D Global Data register	1214			

Chapter 45: LPC18xx DAC

45.1	How to read this chapter.	1218	45.5.1	D/A converter register	1219
45.2	Basic configuration	1218	45.5.2	D/A Converter Control register	1219
45.3	Features	1218	45.5.3	D/A Converter Counter Value register	1220
45.4	Pin description.	1218	45.6	Functional description	1220
45.5	Register description	1219	45.6.1	DMA counter	1220
			45.6.2	Double buffering.	1221

Chapter 46: LPC18xx EEPROM memory

46.1	How to read this chapter.	1222	46.3	Features	1222
46.2	Basic configuration	1222	46.4	General description	1222

46.5	Register description	1223	46.5.2.2	Interrupt enable set register	1227
46.5.1	EEPROM control registers	1224	46.5.2.3	Interrupt status register	1227
46.5.1.1	EEPROM command register	1224	46.5.2.4	Interrupt enable register	1228
46.5.1.2	EEPROM read wait state register	1224	46.5.2.5	Interrupt status clear register	1228
46.5.1.3	EEPROM auto programming register	1225	46.5.2.6	Interrupt status set	1228
46.5.1.4	EEPROM wait state register	1225	46.6	Functional description	1229
46.5.1.5	EEPROM clock divider register	1226	46.6.1	Initialization	1229
46.5.1.6	EEPROM power down register	1226	46.6.2	EEPROM operations	1229
46.5.2	Interrupt registers	1227	46.6.2.1	Writing and erase/programming	1229
46.5.2.1	Interrupt enable clear register	1227			

Chapter 47: LPC18xx JTAG, Serial Wire Debug (SWD), and trace functions

47.1	How to read this chapter	1231	47.6	Debug connections	1233
47.2	Basic configuration	1231	47.6.1	ARM Standard JTAG connector (20-pin)	1233
47.3	Features	1231	47.6.2	Cortex debug connector (10-pin)	1234
47.4	General Description	1231	47.6.3	Cortex Debug + ETM connector (20-pin)	1234
47.4.1	Embedded Trace Macrocell (ETM)	1232	47.7	Debug Notes	1235
47.5	Pin Description	1232	47.8	Debug memory re-mapping	1235
			47.9	JTAG TAP Identification	1235

Chapter 48: LPC18xx API General error codes

48.1	How to read this chapter	1236	48.2	Error codes	1236
-------------	---------------------------------	-------------	-------------	--------------------	-------------

Chapter 49: Supplementary information

49.1	Abbreviations	1239	49.3.3	Trademarks	1241
49.2	References	1240	49.4	Tables	1242
49.3	Legal information	1241	49.5	Figures	1263
49.3.1	Definitions	1241	49.6	Contents	1265
49.3.2	Disclaimers	1241			

Please be aware that important notices concerning this document and the product(s) described herein, have been included in section 'Legal information'.

© NXP B.V. 2017.

All rights reserved.

For more information, please visit: <http://www.nxp.com>

For sales office addresses, please send an email to: salesaddresses@nxp.com

Date of release: 26 July 2017

Document identifier: UM10430

X-ON Electronics

Largest Supplier of Electrical and Electronic Components

Click to view similar products for [Development Boards & Kits - ARM category](#):

Click to view products by [NXP manufacturer](#):

Other Similar products are found below :

[SAFETI-HSK-RM48](#) [PICOHOBBITFL](#) [CC-ACC-MMK-2443](#) [TWR-MC-FRDMKE02Z](#) [EVALSPEAR320CPU](#) [EVB-SCMIMX6SX](#)
[MAX32600-KIT#](#) [TMDX570LS04HDK](#) [TXSD-SV70](#) [OM13080UL](#) [EVAL-ADUC7120QSPZ](#) [OM13082UL](#) [TXSD-SV71](#)
[YGRPEACHNORMAL](#) [OM13076UL](#) [PICODWARFFL](#) [YR8A77450HA02BG](#) [3580](#) [32F3348DISCOVERY](#) [ATTINY1607](#) [CURIOSITY](#)
[NANO](#) [PIC16F15376](#) [CURIOSITY NANO BOARD](#) [PIC18F47Q10](#) [CURIOSITY NANO](#) [VISIONSTK-6ULL V.2.0](#) [80-001428](#) [DEV-17717](#)
[EAK00360](#) [YR0K77210B000BE](#) [RTK7EKA2L1S00001BE](#) [MAX32651-EVKIT#](#) [SLN-VIZN-IOT](#) [LV18F V6 DEVELOPMENT SYSTEM](#)
[READY FOR AVR BOARD](#) [READY FOR PIC BOARD](#) [READY FOR PIC \(DIP28\)](#) [EVB-VF522R3](#) [AVRPLC16 V6 PLC SYSTEM](#)
[MIKROLAB FOR AVR XL](#) [MIKROLAB FOR PIC L](#) [MINI-AT BOARD - 5V](#) [MINI-M4 FOR STELLARIS](#) [MOD-09.Z](#) [BUGGY +](#)
[CLICKER 2 FOR PIC32MX + BLUETOOT](#) [1410](#) [LETS MAKE PROJECT PROGRAM. RELAY PIC](#) [LETS MAKE - VOICE](#)
[CONTROLLED LIGHTS](#) [LPC-H2294](#) [DSPIC-READY2 BOARD](#) [DSPIC-READY3 BOARD](#) [MIKROBOARD FOR ARM 64-PIN](#)
[MIKROLAB FOR AVR](#)