

## P1012

# P1012 QorIQ Integrated Processor Hardware Specifications

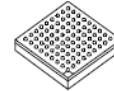

The following list provides an overview of the feature set:

- A high-performance 32-bit core, built on Power Architecture® technology:
    - 36-bit physical addressing
    - Double-precision floating-point support
    - 32 Kbyte L1 instruction cache and 32 Kbyte L1 data cache for each core
    - 533 MHz to 800 MHz clock frequency
  - 256 Kbyte L2 cache with ECC. Also configurable as SRAM and stashing memory.
  - Three 10/100/1000 Mbps enhanced three-speed Ethernet controllers (eTSECs)
    - TCP/IP acceleration, quality of service, and classification capabilities
    - IEEE® 1588 support
    - Lossless flow control
    - MII, RMII, RGMII, SGMII
  - High-speed interfaces supporting various multiplexing options:
    - Four SerDes upto 2.5 GHz/lane multiplexed across controllers
    - Two PCI Express interfaces
    - Two SGMII interfaces
  - High-Speed USB controller (USB 2.0)
    - Host and device support
    - Enhanced host controller interface (EHCI)
    - ULPI interface to PHY
  - Enhanced secure digital host controller (SD/MMC)
  - Enhanced Serial peripheral interface (eSPI)
  - Integrated security engine
    - Protocol support includes ARC4, 3DES, AES, RSA/ECC, RNG, single-pass SSL/TLS
    - XOR acceleration
  - 32-bit DDR2/DDR3 SDRAM memory controller with ECC support
  - Programmable interrupt controller (PIC) compliant with OpenPIC standard
- One four-channel DMA controller
  - Two I<sup>2</sup>C controllers, DUART, timers
  - Enhanced local bus controller (eLBC)
  - QUICC Engine block
  - Operating junction temperature (T<sub>j</sub>) range: 0–125°C and –40°C to 125°C (industrial specification)
  - 31 × 31 mm 689-pin WB-TePBGA II (wire bond temperature-enhanced plastic BGA)

# Table of Contents

1	Pin Assignments and Reset States	4	2.16	JTAG	81
1.1	Ball Layout Diagrams	4	2.17	I2C	83
1.2	Pinout Assignments	9	2.18	High-Speed Serial Interfaces (HSSI)	85
2	Electrical Characteristics	33	2.19	PCI Express	91
2.1	Overall DC Electrical Characteristics	33	3	QIICC Engine Block Specifications	96
2.2	Power Sequencing	36	3.1	Ethernet Interface	96
2.3	Power Down Requirements	37	3.2	HDLC, BISYNC, Transparent, and Synchronous UART Interfaces	99
2.4	RESET Initialization	37	3.3	TDM/SI	102
2.5	Power-on Ramp Rate	38	3.4	UTOPIA Interface	103
2.6	Power Characteristics	38	3.5	SPI Interface	105
2.7	Input Clocks	40	3.6	GPIO	107
2.8	DDR2 and DDR3 SDRAM	44	4	Thermal	108
2.9	eSPI	53	4.1	Thermal Characteristics	108
2.10	DUART	55	4.2	Temperature Diode	109
2.11	Ethernet: Enhanced Three-Speed Ethernet (eTSEC) (10/100/1000 Mbps)—MII/RMII/RGMII/SGMII Electrical Characteristics	56	5	Package Information	109
2.12	USB	72	5.1	Package Parameters for the P1012 WB-TePBGA II	109
2.13	Enhanced Local Bus	75	5.2	Ordering Information	112
2.14	Enhanced Secure Digital Host Controller (eSDHC)	78	6	Product Documentation	112
2.15	Programmable Interrupt Controller (PIC) Specifications	80	7	Revision History	113

This figure shows the major functional units within the P1012.

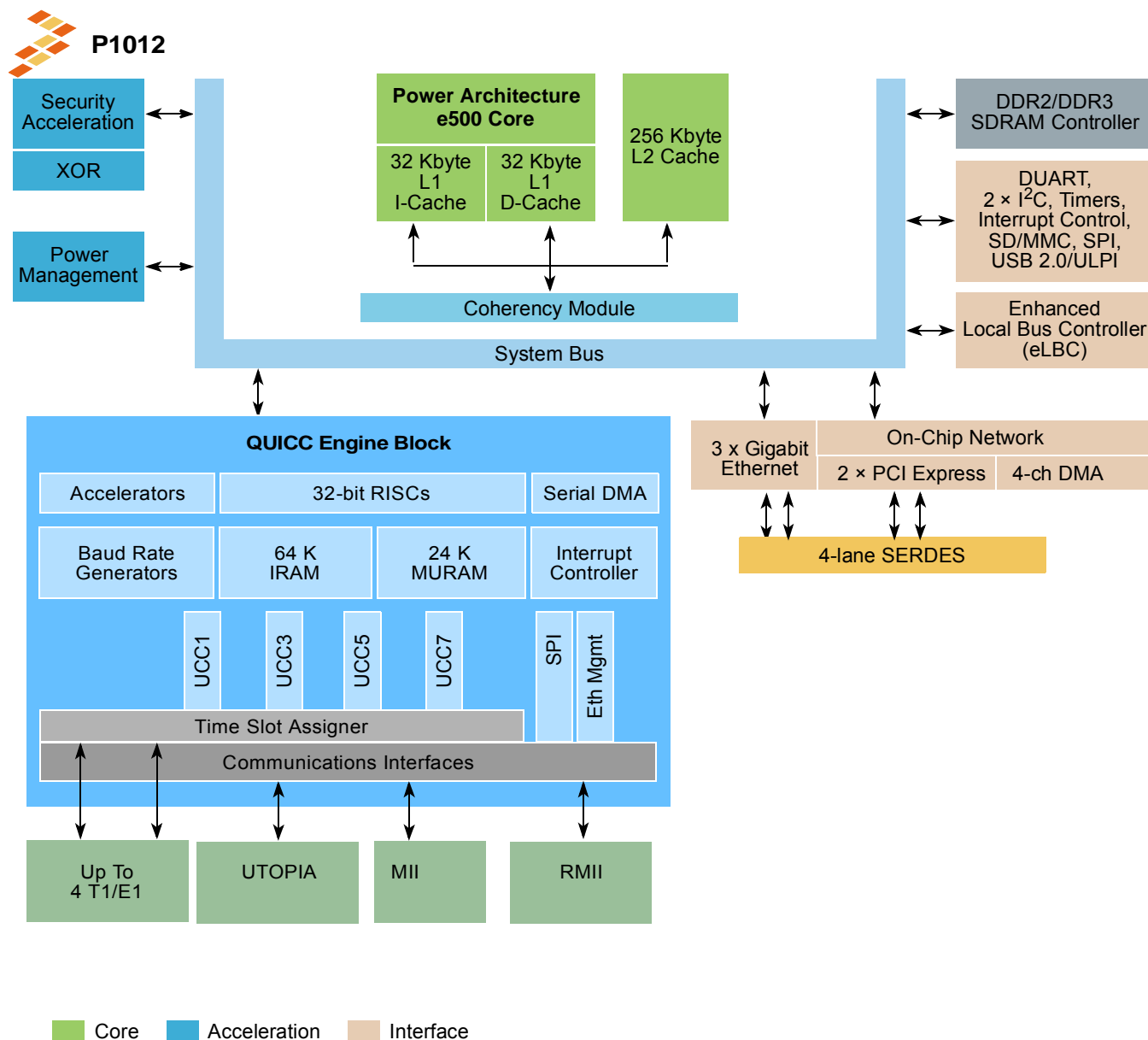

Figure 1. P1012 Block Diagram

# 1 Pin Assignments and Reset States

## 1.1 Ball Layout Diagrams

The following figures show the top view of the 689-pin BGA ball map diagram and detailed quadrant views.

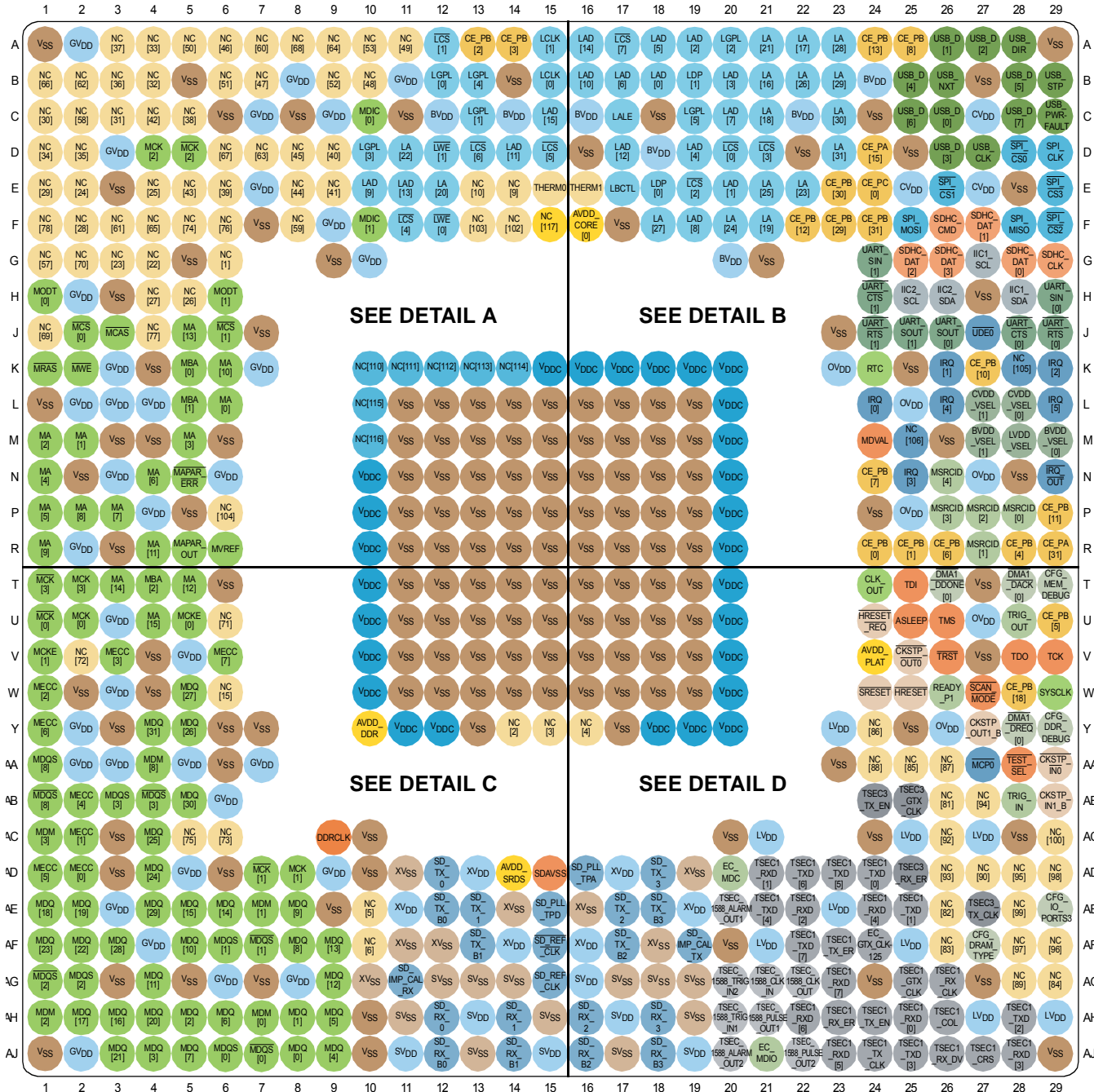
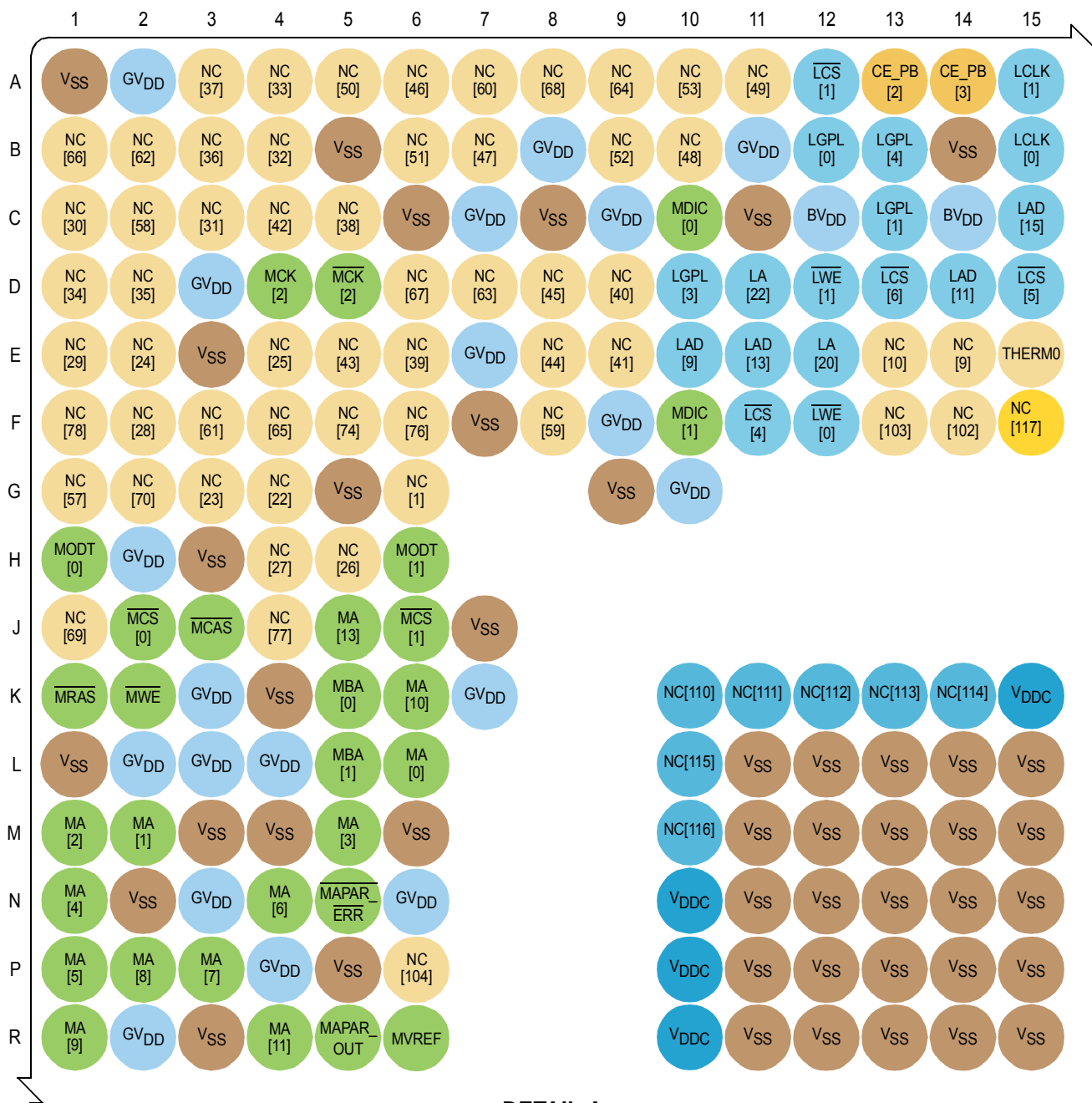

Figure 2. P1012 Top View Ballmap



DETAIL A

Figure 3. P1012 Detail A Ballmap

### Pin Assignments and Reset States

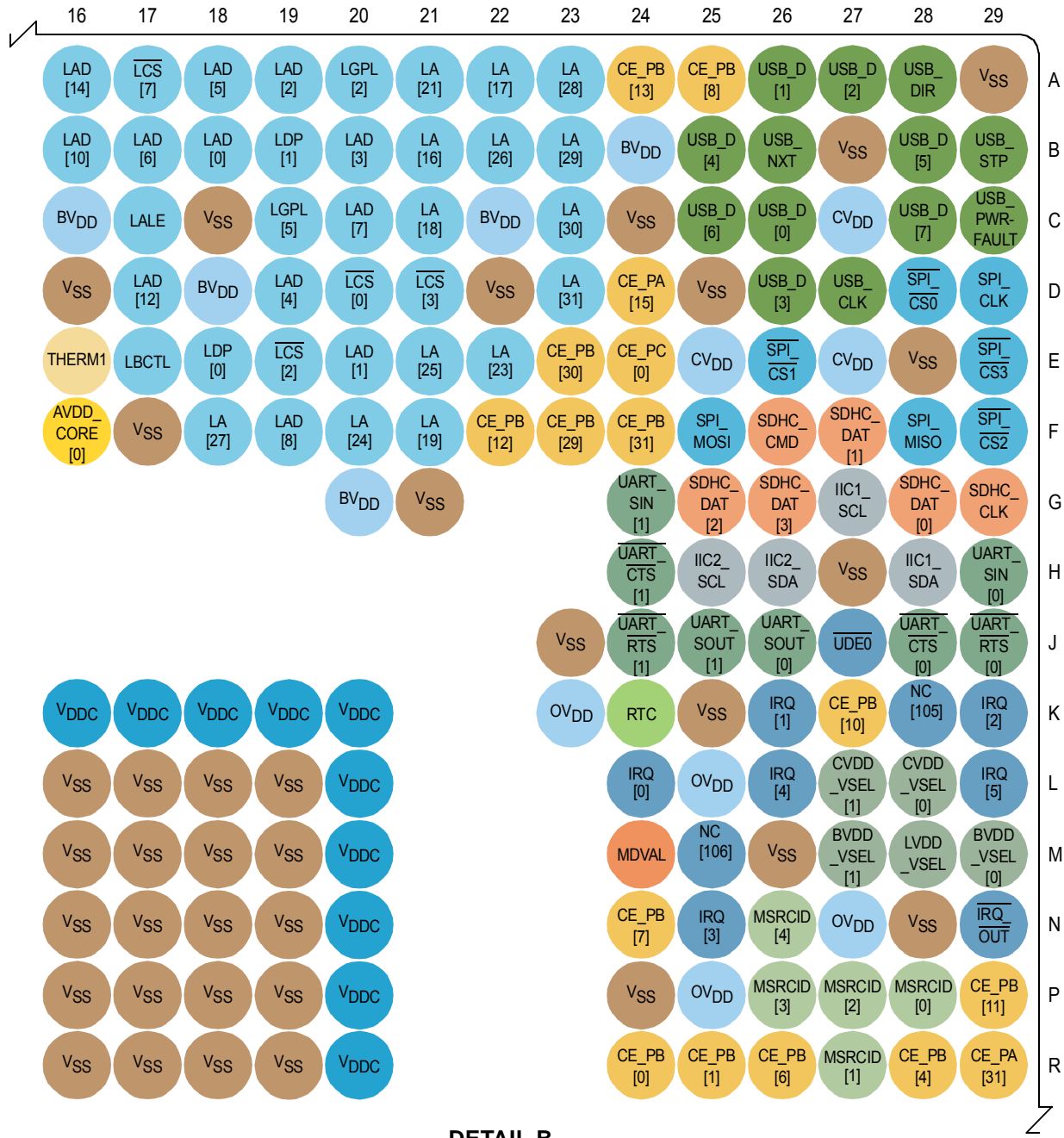

DETAIL B

Figure 4. P1012 Detail B Ballmap



DETAIL D

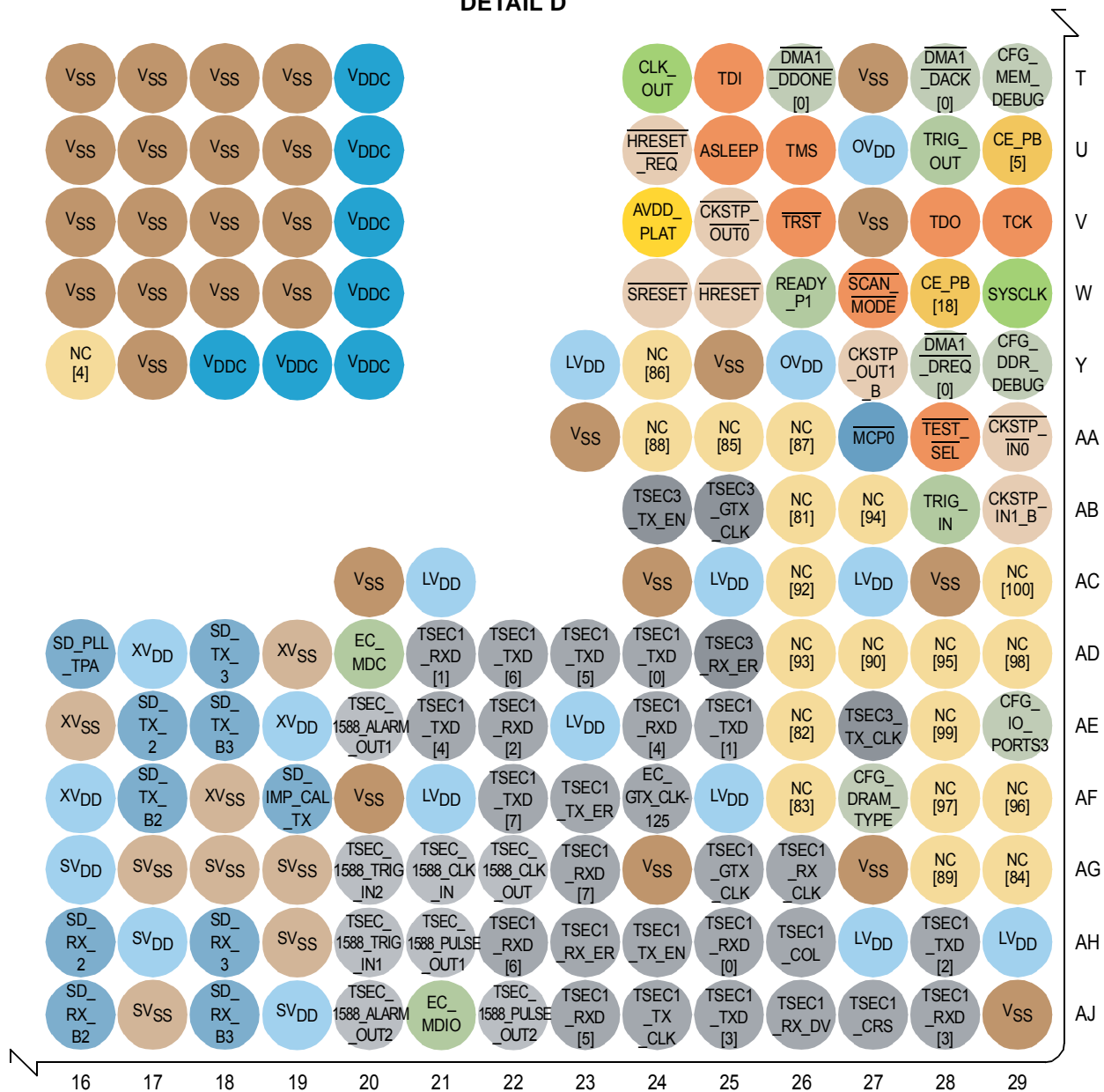

Figure 6. P1012 Detail D Ballmap



## 1.2 Pinout Assignments

This table provides the pinout listing.

**Table 1. P1012 Pinout Listing**

Signal	Package Pin Number	Pin Type	Power Supply	Note
<b>DDR SDRAM Memory Interface</b>				
MDQ00	AJ8	I/O	GV <sub>DD</sub>	—
MDQ01	AH8	I/O	GV <sub>DD</sub>	—
MDQ02	AH5	I/O	GV <sub>DD</sub>	—
MDQ03	AJ4	I/O	GV <sub>DD</sub>	—
MDQ04	AJ9	I/O	GV <sub>DD</sub>	—
MDQ05	AH9	I/O	GV <sub>DD</sub>	—
MDQ06	AH6	I/O	GV <sub>DD</sub>	—
MDQ07	AJ5	I/O	GV <sub>DD</sub>	—
MDQ08	AF8	I/O	GV <sub>DD</sub>	—
MDQ09	AE8	I/O	GV <sub>DD</sub>	—
MDQ10	AF5	I/O	GV <sub>DD</sub>	—
MDQ11	AG4	I/O	GV <sub>DD</sub>	—
MDQ12	AG9	I/O	GV <sub>DD</sub>	—
MDQ13	AF9	I/O	GV <sub>DD</sub>	—
MDQ14	AE6	I/O	GV <sub>DD</sub>	—
MDQ15	AE5	I/O	GV <sub>DD</sub>	—
MDQ16	AH3	I/O	GV <sub>DD</sub>	—
MDQ17	AH2	I/O	GV <sub>DD</sub>	—
MDQ18	AE1	I/O	GV <sub>DD</sub>	—
MDQ19	AE2	I/O	GV <sub>DD</sub>	—
MDQ20	AH4	I/O	GV <sub>DD</sub>	—
MDQ21	AJ3	I/O	GV <sub>DD</sub>	—
MDQ22	AF2	I/O	GV <sub>DD</sub>	—
MDQ23	AF1	I/O	GV <sub>DD</sub>	—
MDQ24	AD4	I/O	GV <sub>DD</sub>	—
MDQ25	AC4	I/O	GV <sub>DD</sub>	—
MDQ26	Y5	I/O	GV <sub>DD</sub>	—
MDQ27	W5	I/O	GV <sub>DD</sub>	—
MDQ28	AF3	I/O	GV <sub>DD</sub>	—

Table 1. P1012 Pinout Listing (continued)

Signal	Package Pin Number	Pin Type	Power Supply	Note
MDQ29	AE4	I/O	GV <sub>DD</sub>	—
MDQ30	AB5	I/O	GV <sub>DD</sub>	—
MDQ31	Y4	I/O	GV <sub>DD</sub>	—
NC22 G4		NC	—	—
NC23	G3	NC	—	—
NC24	E2	NC	—	—
NC25	E4	NC	—	—
NC26	H5	NC	—	—
NC27	H4	NC	—	—
NC28	F2	NC	—	—
NC29	E1	NC	—	—
NC30	C1	NC	—	—
NC31	C3	NC	—	—
NC32	B4	NC	—	—
NC33	A4	NC	—	—
NC34	D1	NC	—	—
NC35	D2	NC	—	—
NC36	B3	NC	—	—
NC37	A3	NC	—	—
NC38	C5	NC	—	—
NC39	E6	NC	—	—
NC40	D9	NC	—	—
NC41	E9	NC	—	—
NC42	C4	NC	—	—
NC43	E5	NC	—	—
NC44	E8	NC	—	—
NC45	D8	NC	—	—
NC46	A6	NC	—	—
NC47	B7	NC	—	—
NC48	B10	NC	—	—
NC49	A11	NC	—	—
NC50	A5	NC	—	—
NC51	B6	NC	—	—

Table 1. P1012 Pinout Listing (continued)

Signal	Package Pin Number	Pin Type	Power Supply	Note
NC52	B9	NC	—	—
NC53	A10	NC	—	—
MECC00	AD2	I/O	GV <sub>DD</sub>	—
MECC01	AC2	I/O	GV <sub>DD</sub>	—
MECC02	W1	I/O	GV <sub>DD</sub>	—
MECC03	V3	I/O	GV <sub>DD</sub>	—
MECC04	AB2	I/O	GV <sub>DD</sub>	—
MECC05	AD1	I/O	GV <sub>DD</sub>	—
MECC06	Y1	I/O	GV <sub>DD</sub>	—
MECC07	V6	I/O	GV <sub>DD</sub>	—
MAPAR_ERR_B	N5	I	GV <sub>DD</sub>	—
MAPAR_OUT	R5	O	GV <sub>DD</sub>	—
MDM00	AH7	O	GV <sub>DD</sub>	—
MDM01	AE7	O	GV <sub>DD</sub>	—
MDM02	AH1	O	GV <sub>DD</sub>	—
MDM03	AC1	O	GV <sub>DD</sub>	—
NC57	G1	NC	—	—
NC58	C2	NC	—	—
NC59	F8	NC	—	—
NC60	A7	NC	—	—
MDM08	AA4	O	GV <sub>DD</sub>	—
MDQS00	AJ6	I/O	GV <sub>DD</sub>	—
MDQS01	AF6	I/O	GV <sub>DD</sub>	—
MDQS02	AG2	I/O	GV <sub>DD</sub>	—
MDQS03	AB3	I/O	GV <sub>DD</sub>	—
NC61	F3	NC	—	—
NC62	B2	NC	—	—
NC63	D7	NC	—	—
NC64	A9	NC	—	—
MDQS08	AA1	I/O	GV <sub>DD</sub>	—
MDQS_B00	AJ7	I/O	GV <sub>DD</sub>	—
MDQS_B01	AF7	I/O	GV <sub>DD</sub>	—
MDQS_B02	AG1	I/O	GV <sub>DD</sub>	—

Table 1. P1012 Pinout Listing (continued)

Signal	Package Pin Number	Pin Type	Power Supply	Note
MDQS_B03	AB4	I/O	GV <sub>DD</sub>	—
NC65	F4	NC	—	—
NC66	B1	NC	—	—
NC67	D6	NC	—	—
NC68	A8	NC	—	—
MDQS_B08	AB1	I/O	GV <sub>DD</sub>	—
MBA00	K5	O	GV <sub>DD</sub>	—
MBA01	L5	O	GV <sub>DD</sub>	—
MBA02	T4	O	GV <sub>DD</sub>	—
MA00	L6	O	GV <sub>DD</sub>	—
MA01	M2	O	GV <sub>DD</sub>	—
MA02	M1	O	GV <sub>DD</sub>	—
MA03	M5	O	GV <sub>DD</sub>	—
MA04	N1	O	GV <sub>DD</sub>	—
MA05	P1	O	GV <sub>DD</sub>	—
MA06	N4	O	GV <sub>DD</sub>	—
MA07	P3	O	GV <sub>DD</sub>	—
MA08	P2	O	GV <sub>DD</sub>	—
MA09	R1	O	GV <sub>DD</sub>	—
MA10	K6	O	GV <sub>DD</sub>	—
MA11	R4	O	GV <sub>DD</sub>	—
MA12	T5	O	GV <sub>DD</sub>	—
MA13	J5	O	GV <sub>DD</sub>	—
MA14	T3	O	GV <sub>DD</sub>	—
MA15	U4	O	GV <sub>DD</sub>	—
MWE_B	K2	O	GV <sub>DD</sub>	—
MRAS_B	K1	O	GV <sub>DD</sub>	—
MCAS_B	J3	O	GV <sub>DD</sub>	—
MCS_B00	J2	O	GV <sub>DD</sub>	—
MCS_B01	J6	O	GV <sub>DD</sub>	—
NC69	J1	NC	—	—
NC70	G2	NC	—	—
MCKE00	U5	O	GV <sub>DD</sub>	8

Table 1. P1012 Pinout Listing (continued)

Signal	Package Pin Number	Pin Type	Power Supply	Note
MCKE01	V1	O	GV <sub>DD</sub>	8
NC71	U6	NC	—	—
NC72	V2	NC	—	—
MCK00	U2	O	GV <sub>DD</sub>	—
MCK01	AD8	O	GV <sub>DD</sub>	—
MCK02	D4	O	GV <sub>DD</sub>	—
MCK03	T2	O	GV <sub>DD</sub>	—
NC73	AC6	NC	—	—
NC74	F5	NC	—	—
MCK_B00	U1	O	GV <sub>DD</sub>	—
MCK_B01	AD7	O	GV <sub>DD</sub>	—
MCK_B02	D5	O	GV <sub>DD</sub>	—
MCK_B03	T1	O	GV <sub>DD</sub>	—
NC75	AC5	NC	—	—
NC76	F6	NC	—	—
MODT00	H1	O	GV <sub>DD</sub>	—
MODT01	H6	O	GV <sub>DD</sub>	—
NC77	J4	NC	—	—
NC78	F1	NC	—	—
MDIC00	C10	I/O	GV <sub>DD</sub>	14
MDIC01	F10	I/O	GV <sub>DD</sub>	14
<b>SerDes</b>				
SD_TX_3	AD18	O	XV <sub>DD_SRDS</sub>	—
SD_TX_2	AE17	O	XV <sub>DD_SRDS</sub>	—
SD_TX_1	AE13	O	XV <sub>DD_SRDS</sub>	—
SD_TX_0	AD12	O	XV <sub>DD_SRDS</sub>	—
SD_TX_B3	AE18	O	XV <sub>DD_SRDS</sub>	—
SD_TX_B2	AF17	O	XV <sub>DD_SRDS</sub>	—
SD_TX_B1	AF13	O	XV <sub>DD_SRDS</sub>	—
SD_TX_B0	AE12	O	XV <sub>DD_SRDS</sub>	—
SD_RX_3	AH18	I	SV <sub>DD_SRDS</sub>	—
SD_RX_2	AH16	I	SV <sub>DD_SRDS</sub>	—

**Table 1. P1012 Pinout Listing (continued)**

Signal	Package Pin Number	Pin Type	Power Supply	Note
SD_RX_1	AH14	I	SV <sub>DD</sub> _SRDS	—
SD_RX_0	AH12	I	SV <sub>DD</sub> _SRDS	—
SD_RX_B3	AJ18	I	SV <sub>DD</sub> _SRDS	—
SD_RX_B2	AJ16	I	SV <sub>DD</sub> _SRDS	—
SD_RX_B1	AJ14	I	SV <sub>DD</sub> _SRDS	—
SD_RX_B0	AJ12	I	SV <sub>DD</sub> _SRDS	—
SD_REF_CLK	AG15	I	SV <sub>DD</sub> _SRDS	—
SD_REF_CLK_B	AF15	I	SV <sub>DD</sub> _SRDS	—
SD_PLL_TPD	AE15	O	XV <sub>DD</sub> _SRDS	10
SD_IMP_CAL_RX	AG11	I	XV <sub>DD</sub> _SRDS	23
SD_IMP_CAL_TX	AF19	I	XV <sub>DD</sub> _SRDS	23
SD_PLL_TPA	AD16	O	XV <sub>DD</sub> _SRDS	10
<b>Enhanced Local Bus Controller Interface</b>				
LAD00	B18	I/O	BV <sub>DD</sub>	4, 19
LAD01	E20	I/O	BV <sub>DD</sub>	4, 19
LAD02	A19	I/O	BV <sub>DD</sub>	4, 19
LAD03	B20	I/O	BV <sub>DD</sub>	4, 19
LAD04	D19	I/O	BV <sub>DD</sub>	4, 19
LAD05	A18	I/O	BV <sub>DD</sub>	4, 19
LAD06	B17	I/O	BV <sub>DD</sub>	4, 19
LAD07	C20	I/O	BV <sub>DD</sub>	4, 19
LAD08/CE_PA0	F19	I/O	BV <sub>DD</sub>	4, 19
LAD09 E1	0	I/O	BV <sub>DD</sub>	4, 19
LAD10	B16	I/O	BV <sub>DD</sub>	4, 19
LAD11	D14	I/O	BV <sub>DD</sub>	4, 19
LAD12	D17	I/O	BV <sub>DD</sub>	4, 19
LAD13	E11	I/O	BV <sub>DD</sub>	4, 19
LAD14	A16	I/O	BV <sub>DD</sub>	4, 19
LAD15	C15	I/O	BV <sub>DD</sub>	4, 19
LDP00/CE_PA11	E18	I/O	BV <sub>DD</sub>	7
LDP01/CE_PA12	B19	I/O	BV <sub>DD</sub>	7
LA16/CE_PA4	B21	I/O	BV <sub>DD</sub>	

Table 1. P1012 Pinout Listing (continued)

Signal	Package Pin Number	Pin Type	Power Supply	Note
LA17/CE_PA5	A22	I/O	BV <sub>DD</sub>	13
LA18/CE_PA6	C21	I/O	BV <sub>DD</sub>	4
LA19/CE_PA7	F21	I/O	BV <sub>DD</sub>	4
LA20/CE_PA8	E12	I/O	BV <sub>DD</sub>	4
LA21/CE_PA9	A21	I/O	BV <sub>DD</sub>	4
LA22/CE_PA10	D11	I/O	BV <sub>DD</sub>	4
LA23/CE_PA17	E22	I/O	BV <sub>DD</sub>	4
LA24/CE_PA18	F20	I/O	BV <sub>DD</sub>	4
LA25/CE_PA19	E21	I/O	BV <sub>DD</sub>	4
LA26/CE_PA20	B22	I/O	BV <sub>DD</sub>	4
LA27/CE_PA21	F18	I/O	BV <sub>DD</sub>	20
LA28/CE_PA13 A2	3	I/O	BV <sub>DD</sub>	13
LA29/CE_PA25 B2	3	I/O	BV <sub>DD</sub>	—
LA30/CE_PA26 C	23	I/O	BV <sub>DD</sub>	—
LA31/CE_PA30	D23	I/O	BV <sub>DD</sub>	—
LCS_B00	D20	O	BV <sub>DD</sub>	7
LCS_B01	A12	O	BV <sub>DD</sub>	7
LCS_B02	E19	O	BV <sub>DD</sub>	7
LCS_B03 D2	1	O	BV <sub>DD</sub>	7
LCS_B04/CE_PA22	F11	I/O	BV <sub>DD</sub>	7
LCS_B05/CE_PA23 D1	5	I/O	BV <sub>DD</sub>	7
LCS_B06/CE_PA24 D1	3	O	BV <sub>DD</sub>	7
LCS_B07/CE_PA27	A17	O	BV <sub>DD</sub>	7
LWE_B00	F12	O	BV <sub>DD</sub>	6
LWE_B01/CE_PB9 D1	2	I/O	BV <sub>DD</sub>	
LBCTL/CE_PB20	E17	I/O	BV <sub>DD</sub>	5
LALE	C17	O	BV <sub>DD</sub>	5
LGPL0/CE_PA1	B12	I/O	BV <sub>DD</sub>	
LGPL1/CE_PA2	C13	I/O	BV <sub>DD</sub>	
LGPL2	A20	O	BV <sub>DD</sub>	5
LGPL3/CE_PA3	D10	I/O	BV <sub>DD</sub>	4
LGPL4	B13	I/O	BV <sub>DD</sub>	24
LGPL5	C19	I/O	BV <sub>DD</sub>	4

**Table 1. P1012 Pinout Listing (continued)**

Signal	Package Pin Number	Pin Type	Power Supply	Note
LCLK00/CE_PA28	B15	I/O	BV <sub>DD</sub>	—
LCLK01/CE_PA16	A15	I/O	BV <sub>DD</sub>	—
CE_PB2	A13	I/O	BV <sub>DD</sub>	—
CE_PB3	A14	I/O	BV <sub>DD</sub>	—
<b>DMA</b>				
DMA1_DREQ_B00	Y28	I	OV <sub>DD</sub>	—
CE_PB18	W28	I/O	OV <sub>DD</sub>	—
DMA1_DACK_B00	T28	O	OV <sub>DD</sub>	25
CFG_MEM_DEBUG /CE_PB19	T29	I/O	OV <sub>DD</sub>	—
DMA1_DDONE_B00	T26	O	OV <sub>DD</sub>	13
CFG_DDR_DEBUG /CE_PA29	Y29	I/O	OV <sub>DD</sub>	—
<b>Programmable Interrupt Controller</b>				
UDE0_B	J27	I	OV <sub>DD</sub>	2
NC105	K28	NC	—	—
MCP0_B	AA27	I	OV <sub>DD</sub>	2
NC106	M25	NC	—	—
IRQ00	L24	I	OV <sub>DD</sub>	—
IRQ01	K26	I	OV <sub>DD</sub>	—
IRQ02	K29	I	OV <sub>DD</sub>	—
IRQ03	N25	I	OV <sub>DD</sub>	—
IRQ04	L26	I	OV <sub>DD</sub>	—
IRQ05	L29	I	OV <sub>DD</sub>	—
IRQ06 / CE_PB10	K27	I	OV <sub>DD</sub>	—
IRQ_OUT_B	N29	O	OV <sub>DD</sub>	2, 3
<b>Voltage Select</b>				
LVDD_VSEL	M28	I	OV <sub>DD</sub>	18
BVDD_VSEL0	M29	I	OV <sub>DD</sub>	18
BVDD_VSEL1	M27	I	OV <sub>DD</sub>	18
CVDD_VSEL0	L28	I	OV <sub>DD</sub>	18
CVDD_VSEL1	L27	I	OV <sub>DD</sub>	18
<b>1588</b>				
TSEC_1588_CLK_IN	AG21	I	LV <sub>DD</sub>	—



Table 1. P1012 Pinout Listing (continued)

Signal	Package Pin Number	Pin Type	Power Supply	Note
TSEC_1588_TRIG_IN1	AH20	I	LV <sub>DD</sub>	—
TSEC_1588_TRIG_IN2	AG20	I	LV <sub>DD</sub>	—
TSEC_1588_ALARM_OUT1	AE20	O	LV <sub>DD</sub>	4, 6
TSEC_1588_ALARM_OUT2	AJ20	O	LV <sub>DD</sub>	4, 6
TSEC_1588_CLK_OUT	AG22	O	LV <sub>DD</sub>	4, 6
TSEC_1588_PULSE_OUT1	AH21	O	LV <sub>DD</sub>	4, 6
TSEC_1588_PULSE_OUT2	AJ22	O	LV <sub>DD</sub>	4, 6
<b>Ethernet Management Interface</b>				
EC_MDC	AD20	O	LV <sub>DD</sub>	4, 6
EC_MDIO	AJ21	I/O	LV <sub>DD</sub>	—
<b>Gigabit Ethernet Reference Clock</b>				
EC_GTX_CLK125	AF24	I	LV <sub>DD</sub>	16
<b>Enhanced Three Speed Ethernet Controller 1</b>				
TSEC1_TXD07/TSEC3_TXD03	AF22	O	LV <sub>DD</sub>	4, 6
TSEC1_TXD06/TSEC3_TXD02	AD22	O	LV <sub>DD</sub>	4, 6
TSEC1_TXD05/TSEC3_TXD01	AD23	O	LV <sub>DD</sub>	4, 6
TSEC1_TXD04/TSEC3_TXD00	AE21	O	LV <sub>DD</sub>	4, 6
TSEC1_TXD03	AJ25	O	LV <sub>DD</sub>	4, 6
TSEC1_TXD02	AH28	O	LV <sub>DD</sub>	4, 6
TSEC1_TXD01	AE25	O	LV <sub>DD</sub>	4, 6
TSEC1_TXD00	AD24	O	LV <sub>DD</sub>	4, 6
TSEC1_TX_EN	AH24	O	LV <sub>DD</sub>	22
TSEC1_TX_ER	AF23	O	LV <sub>DD</sub>	4, 6
TSEC1_TX_CLK/ TSEC1_GTX_CLK125	AJ24	I	LV <sub>DD</sub>	—
TSEC1_GTX_CLK	AG25	O	LV <sub>DD</sub>	—
TSEC1_CRS/TSEC3_RX_DV	AJ27	I/O	LV <sub>DD</sub>	—
TSEC1_COL/TSEC3_RX_CLK	AH26	I	LV <sub>DD</sub>	—
TSEC1_RXD07/TSEC3_RXD03	AG23	I	LV <sub>DD</sub>	—
TSEC1_RXD06/TSEC3_RXD02	AH22	I	LV <sub>DD</sub>	—
TSEC1_RXD05/TSEC3_RXD01	AJ23	I	LV <sub>DD</sub>	—
TSEC1_RXD04/TSEC3_RXD00	AE24	I	LV <sub>DD</sub>	—

**Table 1. P1012 Pinout Listing (continued)**

Signal	Package Pin Number	Pin Type	Power Supply	Note
TSEC1_RXD03	AJ28	I	LV <sub>DD</sub>	—
TSEC1_RXD02	AE22	I	LV <sub>DD</sub>	—
TSEC1_RXD01	AD21	I	LV <sub>DD</sub>	—
TSEC1_RXD00	AH25	I	LV <sub>DD</sub>	—
TSEC1_RX_DV	AJ26	I	LV <sub>DD</sub>	—
TSEC1_RX_ER	AH23	I	LV <sub>DD</sub>	—
TSEC1_RX_CLK	AG26	I	LV <sub>DD</sub>	—
<b>Three Speed Ethernet Controller 3</b>				
NC82 AE26		NC	—	—
NC83 AF26		NC	—	—
TSEC3_TX_EN	AB24	O	LV <sub>DD</sub>	<a href="#">22</a>
TSEC3_GTX_CLK	AB25	O	LV <sub>DD</sub>	—
NC84 AG29		NC	—	—
NC85	AA25	NC	—	—
CFG_DRAM_TYPE	AF27	I	LV <sub>DD</sub>	—
NC86 Y2	4	NC	—	—
NC87	AA26	NC	—	—
CFG_IO_PORTS3	AE29	I	LV <sub>DD</sub>	—
NC88 AA24		NC	—	—
NC89 AG28		NC	—	—
TSEC3_RX_ER	AD25	I/O	LV <sub>DD</sub>	—
TSEC3_TX_CLK	AE27	I	LV <sub>DD</sub>	—
NC90 AD27		NC	—	—
NC91	AB26	NC	—	—
NC92	AC26	NC	—	—
NC93	AD26	NC	—	—
NC94 AB27		NC	—	—
NC95 AD28		NC	—	—
NC96 AF29		NC	—	—
NC97 AF28		NC	—	—
NC98 AD29		NC	—	—
NC99 AE28		NC	—	—

Table 1. P1012 Pinout Listing (continued)

Signal	Package Pin Number	Pin Type	Power Supply	Note
NC100 AC29		NC	—	—
<b>DUART</b>				
UART_SOUT00	J26	O	OV <sub>DD</sub>	17
UART_SOUT01/CE_PB17 J	25	I/O	OV <sub>DD</sub>	
UART_SIN00	H29	I	OV <sub>DD</sub>	—
UART_SIN01/CE_PB16 G	24	I/O	OV <sub>DD</sub>	—
UART_CTS_B00	J28	I	OV <sub>DD</sub>	—
UART_CTS_B01/CE_PB14 H2	4	I/O	OV <sub>DD</sub>	—
UART_RTS_B00	J29	O	OV <sub>DD</sub>	5
UART_RTS_B01/CE_PB15 J	24	O	OV <sub>DD</sub>	5
<b>I2C</b>				
IIC1	H28	I/O	OV <sub>DD</sub>	3, 12
IIC1_SCL	G27	I/O	OV <sub>DD</sub>	3, 12
IIC2_SDA/CE_PB21	H26	I/O	OV <sub>DD</sub>	12
IIC2_SCL/CE_PB22	H25	I/O	OV <sub>DD</sub>	12
<b>eSDHC</b>				
SDHC_DATA00	G28	I/O	CV <sub>DD</sub>	—
SDHC_DATA01	F27	I/O	CV <sub>DD</sub>	—
SDHC_DATA02	G25	I/O	CV <sub>DD</sub>	—
SDHC_DATA03	G26	I/O	CV <sub>DD</sub>	—
SDHC_CMD	F26	I/O	CV <sub>DD</sub>	—
SDHC_CLK	G29	O	CV <sub>DD</sub>	—
<b>SPI</b>				
SPI_MISO	F28	I	CV <sub>DD</sub>	—
SPI_MOSI	F25	I/O	CV <sub>DD</sub>	—
SPI_CS0_B/SDHC_DATA04	D28	I/O	CV <sub>DD</sub>	—
SPI_CS1_B/SDHC_DATA05	E26	I/O	CV <sub>DD</sub>	—
SPI_CS2_B/SDHC_DATA06	F29	I/O	CV <sub>DD</sub>	—
SPI_CS3_B/SDHC_DATA07	E29	I/O	CV <sub>DD</sub>	—
SPI_CLK	D29	O	CV <sub>DD</sub>	—
<b>USB</b>				
USB_NXT	B26	I	CV <sub>DD</sub>	—

**Table 1. P1012 Pinout Listing (continued)**

Signal	Package Pin Number	Pin Type	Power Supply	Note
USB_DIR	A28	I	CV <sub>DD</sub>	—
USB_STP	B29	O	CV <sub>DD</sub>	25
USB_PWRFAULT	C29	I	CV <sub>DD</sub>	—
USB_CLK	D27	I	CV <sub>DD</sub>	—
USB_D07	C28	I/O	CV <sub>DD</sub>	—
USB_D06	C25	I/O	CV <sub>DD</sub>	—
USB_D05	B28	I/O	CV <sub>DD</sub>	—
USB_D04	B25	I/O	CV <sub>DD</sub>	—
USB_D03	D26	I/O	CV <sub>DD</sub>	—
USB_D02	A27	I/O	CV <sub>DD</sub>	—
USB_D01	A26	I/O	CV <sub>DD</sub>	—
USB_D00	C26	I/O	CV <sub>DD</sub>	—
<b>General-Purpose Input/Output</b>				
CE_PB4	R28	I/O	OV <sub>DD</sub>	—
CE_PB6	R26	I/O	OV <sub>DD</sub>	—
CE_PB11	P29	I/O	OV <sub>DD</sub>	—
CE_PB7	N24	I/O	OV <sub>DD</sub>	—
CE_PB5	U29	I/O	OV <sub>DD</sub>	—
CE_PB0	R24	I/O	OV <sub>DD</sub>	—
CE_PA31	R29	I/O	OV <sub>DD</sub>	—
CE_PB1	R25	I/O	OV <sub>DD</sub>	—
SDHC_CD/CE_PB12	F22	I/O	BV <sub>DD</sub>	—
SDHC_WP/CE_PB13	A24	I/O	BV <sub>DD</sub>	—
USB_PCTL0/CE_PB8	A25	I/O	BV <sub>DD</sub>	—
USB_PCTL1/CE_PA15	D24	I/O	BV <sub>DD</sub>	—
CE_PB29	F23	I/O	BV <sub>DD</sub>	—
CE_PB30	E23	I/O	BV <sub>DD</sub>	—
CE_PB31	F24	I/O	BV <sub>DD</sub>	—
CE_PC0	E24	I/O	BV <sub>DD</sub>	—
<b>System Control</b>				
HRESET_B	W25	I	OV <sub>DD</sub>	—
HRESET_REQ_B	U24	O	OV <sub>DD</sub>	13

Table 1. P1012 Pinout Listing (continued)

Signal	Package Pin Number	Pin Type	Power Supply	Note
SRESET_B	W24	I	OV <sub>DD</sub>	—
CKSTP_IN0_B	AA29	I	OV <sub>DD</sub>	2
CKSTP_IN1_B AB29		I	OV <sub>DD</sub>	2
CKSTP_OUT0_B	V25	O	OV <sub>DD</sub>	2, 3
CKSTP_OUT1_B Y2	7	O	OV <sub>DD</sub>	2, 3
<b>Debug</b>				
TRIG_IN	AB28	I	OV <sub>DD</sub>	—
TRIG_OUT	U28	O	OV <sub>DD</sub>	6, 13
READY_P1 W	26	O	OV <sub>DD</sub>	6
MSRCID00/LB_MSRCID00/ PLL_PER_OUT00/CE_PB23	P28	I/O	OV <sub>DD</sub>	—
MSRCID01/LB_MSRCID01/ PLL_PER_OUT01/CE_PB24	R27	I/O	OV <sub>DD</sub>	13
MSRCID02/LB_MSRCID02/ PLL_PER_OUT02/CE_PB25	P27	I/O	OV <sub>DD</sub>	13
MSRCID03/LB_MSRCID03/ PLL_PER_OUT03/CE_PB26	P26	I/O	OV <sub>DD</sub>	13
MSRCID04/LB_MSRCID04/ PLL_UP_DN/CE_PB27	N26	I/O	OV <sub>DD</sub>	17
MDVAL/LB_MDVAL/ PLL_PER_VALID/CE_PB28	M24	I/O	OV <sub>DD</sub>	13
<b>Clocks</b>				
CLK_OUT	T24	O	OV <sub>DD</sub>	8
RTC	K24	I	OV <sub>DD</sub>	—
DDRCLK	AC9	I	OV <sub>DD</sub>	15
SYSCLK	W29	I	OV <sub>DD</sub>	—
<b>DFT</b>				
SCAN_MODE_B	W27	I	OV <sub>DD</sub>	13
TEST_SEL_B	AA28	I	OV <sub>DD</sub>	25
<b>JTAG</b>				
TCK	V29	I	OV <sub>DD</sub>	—
TDI	T25	I	OV <sub>DD</sub>	9
TDO	V28	O	OV <sub>DD</sub>	8
TMS	U26	I	OV <sub>DD</sub>	9

Table 1. P1012 Pinout Listing (continued)

Signal	Package Pin Number	Pin Type	Power Supply	Note
TRST_B	V26	I	OV <sub>DD</sub>	9
<b>Power Management</b>				
ASLEEP	U25	O	OV <sub>DD</sub>	13
NC1	G6	NC	—	—
NC2	Y14	NC	—	—
NC3	Y15	NC	—	—
NC4	Y16	NC	—	—
NC5	AE10	NC	—	—
NC6	AF10	NC	—	—
NC9	E14	NC	—	—
NC10	E13	NC	—	—
NC15	W6	NC	—	—
<b>Power and Ground Signals</b>				
GND	AH10	—	—	—
GND	AJ10	—	—	—
GND	AD10	—	—	—
THERM1	E16	Internal Diode Anode	—	26
THERM0	E15	Internal Diode Cathode	—	26
AGND_SRDS	AD15	—	—	—
AV <sub>DD</sub> _CORE0	F16	—	—	11, 21
NC117	F15	NC	—	—
AV <sub>DD</sub> _DDR	Y10	—	—	11
NC102	F14	NC	—	—
AV <sub>DD</sub> _PLAT	V24	—	—	11
AV <sub>DD</sub> _SRDS	AD14	—	—	11
BV <sub>DD</sub>	B24	—	—	—
BV <sub>DD</sub>	C12	—	—	—
BV <sub>DD</sub>	C14	—	—	—
BV <sub>DD</sub>	C16	—	—	—
BV <sub>DD</sub>	C22	—	—	—
BV <sub>DD</sub>	D18	—	—	—

Table 1. P1012 Pinout Listing (continued)

Signal	Package Pin Number	Pin Type	Power Supply	Note
BV <sub>DD</sub>	G20	—	—	—
CV <sub>DD</sub>	C27	—	—	—
CV <sub>DD</sub>	E25	—	—	—
CV <sub>DD</sub>	E27	—	—	—
GV <sub>DD</sub>	A2	—	—	—
GV <sub>DD</sub>	B8	—	—	—
GV <sub>DD</sub>	B11	—	—	—
GV <sub>DD</sub>	C7	—	—	—
GV <sub>DD</sub>	C9	—	—	—
GV <sub>DD</sub>	D3	—	—	—
GV <sub>DD</sub>	E7	—	—	—
GV <sub>DD</sub>	F9	—	—	—
GV <sub>DD</sub>	G10	—	—	—
GV <sub>DD</sub>	H2	—	—	—
GV <sub>DD</sub>	K3	—	—	—
GV <sub>DD</sub>	K7	—	—	—
GV <sub>DD</sub>	L2	—	—	—
GV <sub>DD</sub>	L3	—	—	—
GV <sub>DD</sub>	L4	—	—	—
GV <sub>DD</sub>	N3	—	—	—
GV <sub>DD</sub>	N6	—	—	—
GV <sub>DD</sub>	P4	—	—	—
GV <sub>DD</sub>	R2	—	—	—
GV <sub>DD</sub>	U3	—	—	—
GV <sub>DD</sub>	V5	—	—	—
GV <sub>DD</sub>	W3	—	—	—
GV <sub>DD</sub>	Y2	—	—	—
GV <sub>DD</sub>	AA2	—	—	—
GV <sub>DD</sub>	AA3	—	—	—
GV <sub>DD</sub>	AA5	—	—	—
GV <sub>DD</sub>	AA7	—	—	—
GV <sub>DD</sub>	AB6	—	—	—
GV <sub>DD</sub>	AD5	—	—	—

Table 1. P1012 Pinout Listing (continued)

Signal	Package Pin Number	Pin Type	Power Supply	Note
GV <sub>DD</sub>	AD9	—	—	—
GV <sub>DD</sub>	AE3	—	—	—
GV <sub>DD</sub>	AF4	—	—	—
GV <sub>DD</sub>	AG6	—	—	—
GV <sub>DD</sub>	AG8	—	—	—
GV <sub>DD</sub>	AJ2	—	—	—
LV <sub>DD</sub>	Y23	—	—	—
LV <sub>DD</sub>	AC21	—	—	—
LV <sub>DD</sub>	AC25	—	—	—
LV <sub>DD</sub>	AC27	—	—	—
LV <sub>DD</sub>	AE23	—	—	—
LV <sub>DD</sub>	AF21	—	—	—
LV <sub>DD</sub>	AF25	—	—	—
LV <sub>DD</sub>	AH27	—	—	—
LV <sub>DD</sub>	AH29	—	—	—
SV <sub>DD_SRDS</sub>	AG16	—	—	—
SV <sub>DD_SRDS</sub>	AH13	—	—	—
SV <sub>DD_SRDS</sub>	AH17	—	—	—
SV <sub>DD_SRDS</sub>	AJ11	—	—	—
SV <sub>DD_SRDS</sub>	AJ15	—	—	—
SV <sub>DD_SRDS</sub>	AJ19	—	—	—
SGND_SRDS	AG12	—	—	—
SGND_SRDS	AG13	—	—	—
SGND_SRDS	AG14	—	—	—
SGND_SRDS	AG17	—	—	—
SGND_SRDS	AG18	—	—	—
SGND_SRDS	AG19	—	—	—
SGND_SRDS	AH11	—	—	—
SGND_SRDS	AH15	—	—	—
SGND_SRDS	AH19	—	—	—
SGND_SRDS	AJ13	—	—	—
SGND_SRDS	AJ17	—	—	—
XV <sub>DD_SRDS</sub>	AD13	—	—	—



Table 1. P1012 Pinout Listing (continued)

Signal	Package Pin Number	Pin Type	Power Supply	Note
XV <sub>DD</sub> _SRDS	AD17	—	—	—
XV <sub>DD</sub> _SRDS	AE11	—	—	—
XV <sub>DD</sub> _SRDS	AE19	—	—	—
XV <sub>DD</sub> _SRDS	AF14	—	—	—
XV <sub>DD</sub> _SRDS	AF16	—	—	—
XGND_SRDS	AD11	—	—	—
XGND_SRDS	AD19	—	—	—
XGND_SRDS	AE14	—	—	—
XGND_SRDS	AE16	—	—	—
XGND_SRDS	AF11	—	—	—
XGND_SRDS	AF12	—	—	—
XGND_SRDS	AF18	—	—	—
XGND_SRDS	AG10	—	—	—
MVREF	R6	—	—	—
OV <sub>DD</sub>	K23	—	—	—
OV <sub>DD</sub>	L25	—	—	—
OV <sub>DD</sub>	N27	—	—	—
OV <sub>DD</sub>	P25	—	—	—
OV <sub>DD</sub>	U27	—	—	—
OV <sub>DD</sub>	Y26	—	—	—
NC103	F13	NC	—	—
NC104 P6		NC	—	—
NC110	K10	NC	—	—
NC111	K11	NC	—	—
NC112	K12	NC	—	—
NC113	K13	NC	—	—
NC114	K14	NC	—	—
NC115	L10	NC	—	—
NC116	M10	NC	—	—
V <sub>DDC</sub>	K15	—	—	—
V <sub>DDC</sub>	K17	—	—	—
V <sub>DDC</sub>	K19	—	—	—
V <sub>DDC</sub>	K16	—	—	—

Table 1. P1012 Pinout Listing (continued)

Signal	Package Pin Number	Pin Type	Power Supply	Note
V <sub>DDC</sub>	L20	—	—	—
V <sub>DDC</sub>	K18	—	—	—
V <sub>DDC</sub>	K20	—	—	—
V <sub>DDC</sub>	N10	—	—	—
V <sub>DDC</sub>	N20	—	—	—
V <sub>DDC</sub>	M20	—	—	—
V <sub>DDC</sub>	R10	—	—	—
V <sub>DDC</sub>	R20	—	—	—
V <sub>DDC</sub>	P10	—	—	—
V <sub>DDC</sub>	P20	—	—	—
V <sub>DDC</sub>	U10	—	—	—
V <sub>DDC</sub>	U20	—	—	—
V <sub>DDC</sub>	T10	—	—	—
V <sub>DDC</sub>	T20	—	—	—
V <sub>DDC</sub>	W10	—	—	—
V <sub>DDC</sub>	V10	—	—	—
V <sub>DDC</sub>	V20	—	—	—
V <sub>DDC</sub>	W20	—	—	—
V <sub>DDC</sub>	Y11	—	—	—
V <sub>DDC</sub>	Y19	—	—	—
GND	A1	—	—	—
GND	A29	—	—	—
GND	B5	—	—	—
GND	B14	—	—	—
GND	B27	—	—	—
GND	C6	—	—	—
GND	C8	—	—	—
GND	C11	—	—	—
GND	C18	—	—	—
GND	C24	—	—	—
GND	D16	—	—	—
GND	D22	—	—	—
GND	D25	—	—	—

Table 1. P1012 Pinout Listing (continued)

Signal	Package Pin Number	Pin Type	Power Supply	Note
GND	E3	—	—	—
GND	E28	—	—	—
GND	F7	—	—	—
GND	G5	—	—	—
GND	G9	—	—	—
GND	G21	—	—	—
GND	H3	—	—	—
GND	H27	—	—	—
GND	J7	—	—	—
GND	J23	—	—	—
GND	K4	—	—	—
GND	F17	—	—	—
GND	L12	—	—	—
GND	L14	—	—	—
GND	L16	—	—	—
GND	L18	—	—	—
GND	M11	—	—	—
GND	K25	—	—	—
GND	L1	—	—	—
GND	L11	—	—	—
GND	L13	—	—	—
GND	L15	—	—	—
GND	L17	—	—	—
GND	L19	—	—	—
GND	M3	—	—	—
GND	M4	—	—	—
GND	M6	—	—	—
GND	M19	—	—	—
GND	M12	—	—	—
GND	M13	—	—	—
GND	M14	—	—	—
GND	M15	—	—	—
GND	M16	—	—	—

Table 1. P1012 Pinout Listing (continued)

Signal	Package Pin Number	Pin Type	Power Supply	Note
GND	M17	—	—	—
GND	M18	—	—	—
GND	P11	—	—	—
GND	M26	—	—	—
GND	N2	—	—	—
GND	N11	—	—	—
GND	N12	—	—	—
GND	N13	—	—	—
GND	N14	—	—	—
GND	N15	—	—	—
GND	N16	—	—	—
GND	N17	—	—	—
GND	N18	—	—	—
GND	N19	—	—	—
GND	N28	—	—	—
GND	P5	—	—	—
GND	P19	—	—	—
GND	P12	—	—	—
GND	P13	—	—	—
GND	P14	—	—	—
GND	P15	—	—	—
GND	P16	—	—	—
GND	P17	—	—	—
GND	P18	—	—	—
GND	T11	—	—	—
GND	P24	—	—	—
GND	R3	—	—	—
GND	R11	—	—	—
GND	R12	—	—	—
GND	R13	—	—	—
GND	R14	—	—	—
GND	R15	—	—	—
GND	R16	—	—	—

Table 1. P1012 Pinout Listing (continued)

Signal	Package Pin Number	Pin Type	Power Supply	Note
GND	R17	—	—	—
GND	R18	—	—	—
GND	R19	—	—	—
GND	T6	—	—	—
GND	T19	—	—	—
GND	T12	—	—	—
GND	T13	—	—	—
GND	T14	—	—	—
GND	T15	—	—	—
GND	T16	—	—	—
GND	T17	—	—	—
GND	T18	—	—	—
GND	V11	—	—	—
GND	T27	—	—	—
GND	U11	—	—	—
GND	U12	—	—	—
GND	U13	—	—	—
GND	U14	—	—	—
GND	U15	—	—	—
GND	U16	—	—	—
GND	U17	—	—	—
GND	U18	—	—	—
GND	U19	—	—	—
GND	V4	—	—	—
GND	V19	—	—	—
GND	V12	—	—	—
GND	V13	—	—	—
GND	V14	—	—	—
GND	V15	—	—	—
GND	V16	—	—	—
GND	V17	—	—	—
GND	V18	—	—	—
GND	W12	—	—	—

Table 1. P1012 Pinout Listing (continued)

Signal	Package Pin Number	Pin Type	Power Supply	Note
GND	V27	—	—	—
GND	W2	—	—	—
GND	W4	—	—	—
GND	W11	—	—	—
GND	W13	—	—	—
GND	W14	—	—	—
GND	W15	—	—	—
GND	W16	—	—	—
GND	W17	—	—	—
GND	W19	—	—	—
GND	Y3	—	—	—
GND	Y6	—	—	—
GND	Y7	—	—	—
GND	W18	—	—	—
V <sub>DDC</sub>	Y12	—	—	—
GND	Y13	—	—	—
GND	Y17	—	—	—
V <sub>DDC</sub>	Y18	—	—	—
V <sub>DDC</sub>	Y20	—	—	—
GND	Y25	—	—	—
GND	AA6	—	—	—
GND	AA23	—	—	—
GND	AC3	—	—	—
GND	AC10	—	—	—
GND	AC20	—	—	—
GND	AC24	—	—	—
GND	AC28	—	—	—
GND	AD3	—	—	—
GND	AD6	—	—	—
GND	AE9	—	—	—
GND	AF20	—	—	—
GND	AG3	—	—	—
GND	AG5	—	—	—

Table 1. P1012 Pinout Listing (continued)

Signal	Package Pin Number	Pin Type	Power Supply	Note
GND	AG7	—	—	—
GND	AG24	—	—	—
GND	AG27	—	—	—
GND	AJ1	—	—	—
GND	AJ29	—	—	—

**Note:**

1. All multiplexed signals are listed only once and do not re-occur.
2. Recommend that a weak pull-up resistor (2–10 K $\Omega$ ) be placed on this pin to OVDD.
3. This pin is an open drain signal.
4. This pin is a reset configuration pin. It has a weak internal pull-up, P-FET, which is enabled only when the processor is in the reset state. This pull-up is designed such that it can be overpowered by an external 4.7-k $\Omega$  pull-down resistor. However, if the signal is intended to be high after reset, and if there is any device on the net which might pull down the value of the net at reset, a pull-up or active driver is needed.
5. The value of LALE, LGPL2, and LBCTL at reset sets the e500 core clock to CCB Cbck PLL ratio. These pins require 4.7-k $\Omega$  pull-up or pull-down resistors. See *P1021 QorIQ Integrated Processor Reference Manual* for clock ratio settings.
6. Functionally, this pin is an output, but structurally it is an I/O because it either samples configuration input during reset or because it has other manufacturing test functions. This pin is described as an I/O for boundary scan.
7. If this pin is configured for local bus controller usage, it is recommended that a weak pull-up resistor (2–10 K $\Omega$ ) be placed on this pin to BVDD, ensuring that there is no random chip select assertion due to possible noise or other factors.
8. This output is actively driven during reset rather than being three-stated during reset.
9. These JTAG pins have weak internal pull-up P-FETs that are always enabled.
10. Do not connect.
11. Independent supplies derived from board VDD.
12. Recommend that a pull-up resistor (~1 k $\Omega$ ) be placed on this pin to OVDD.
13. These pins must NOT be pulled down by a resistor or the component they are connected to during power-on reset: LA28, LA17, HRESET\_REQ, MSRCID[1:3], MDVAL, ASLEEP, DMA1\_DDONE\_B00, SCAN\_MODE\_B, TRIG\_OUT.
14. For DDR2 MDIC[0] is grounded through an 18.2- $\Omega$  (full-strength mode) or 36.4- $\Omega$  (half-strength mode) precision 1% resistor and Dn\_MDIC[1] is connected to GVDD through an 18.2- $\Omega$  (full-strength mode) or 36.4- $\Omega$  (half-strength mode) precision 1% resistor. These pins are used for automatic calibration of the DDR IOs. The calibration resistor value for DDR3 should be 20- $\Omega$  (full-strength mode) or 40- $\Omega$  (half-strength mode).

**Table 1. P1012 Pinout Listing (continued)**

Signal	Package Pin Number	Pin Type	Power Supply	Note
--------	--------------------	----------	--------------	------

15. DDRCLK input is only required when the P1012DDR controller is running in asynchronous mode. When the DDR controller is configured to run in synchronous mode via POR setting `cfg_ddr_pll[0:2] = 111`, the DDRCLK input is not required. It is recommended that users tie it off to GND when DDR controller is running in synchronous mode. See the “Clock Signals” section and the “DDR Complex Clock PLL Ratio” table in the “DDR PLL Ratio” section of the *P1021 QorIQ Integrated Host Processor Family Reference Manual*, for a more detailed description of DDR controller operation in asynchronous and synchronous modes.
16. EC\_GTX\_CLK125 is a 125-MHz input clock shared among all eTSEC ports in the following modes: RGMII. If none of the eTSEC ports is operating in these modes, the EC\_GTX\_CLK125 input can be tied off to GND.
17. These POR configuration inputs may be used in the future to control functionality. It is advised that boards are built with the ability to pull-down these pins. LA[20:22], UART\_SOUT[0], and MSRCID[4] are reserved for future reset configuration.
18. Incorrect settings can lead to irreversible device damage.
19. The value of LAD[0:15] during reset sets the upper 16 bits of the GPPORCR.
20. The value of LA27 during reset is used to determine CPU boot configuration. See the “CPU Boot POR Configuration,” section in the applicable device reference manual.
21. It must be the same as  $V_{DD\_Core}$ .
22. When eTSEC1 and eTSEC3 are used as parallel interfaces, pins TSEC1\_TX\_EN and TSEC3\_TX\_EN requires an external 4.7-k $\Omega$  pull-down resistor to prevent PHY from seeing a valid Transmit Enable before it is actively driven. However, because of the pull-down resistor on TSEC3\_TX\_EN cause the eSDHC card-detect (`cfg_sdhc_cd_pol_sel`) to be inverted, the inversion should be overridden from the SDHCDCR [CD\_INV] debug control register.
23. SD\_IMP\_CAL\_RX should be grounded through an 200- $\Omega$  precision 1% resistor and SD\_MP\_CAL\_TX is grounded through an 100- $\Omega$  precision 1% resistor.
24. For systems which boot from Local Bus (GPCM)-controlled NOR flash or (FCM)-controlled NAND flash, a pull-up on LGPL4 is required.
25. Refer to AN4259 for the correct settings.
26. These pins may be connected to a temperature diode monitoring device such as the On Semiconductor, NCT1008™. If a temperature diode monitoring device is not connected, these pins may be connected to test point or left as a no connect.



## 2 Electrical Characteristics

This section provides the AC and DC electrical specifications. The processor is currently targeted to these specifications. Some of these specifications are independent of the I/O cell, but are included for a more complete reference. These are not purely I/O buffer design specifications.

### 2.1 Overall DC Electrical Characteristics

This section covers the ratings, conditions, and other characteristics.

#### 2.1.1 Absolute Maximum Ratings

This table provides the absolute maximum ratings.

**Table 2. Absolute Maximum Ratings<sup>1</sup>**

Characteristic		Symbol	Max Value	Unit	Note
Core 0 and platform supply voltage		$V_{DDC}$	-0.3 to 1.05	V	—
PLL supply voltage		$AV_{DD\_CORE0}$ $AV_{DD\_DDR}$ $AV_{DD\_PLAT}$ $AV_{DD\_SRDS}$	-0.3 to 1.05	V	8
Core power supply for SerDes transceivers		$SV_{DD\_SRDS}$	-0.3 to 1.05	V	—
Pad power supply for SerDes transceivers		$XV_{DD\_SRDS}$	-0.3 to 1.05	V	—
DDR2/3 DRAM I/O voltage		$GV_{DD}$	-0.3 to 1.98	V	—
Three-speed Ethernet I/O, MII management voltage (eTSEC)		$LV_{DD}$	-0.3 to 3.63 -0.3 to 2.75	V	1, 4
DUART, system control and power management, I <sup>2</sup> C, and JTAG I/O voltage		$OV_{DD}$	-0.3 to 3.63	V	—
USB, eSPI, eSDHC		$CV_{DD}$	-0.3 to 3.63 -0.3 to 2.75 -0.3 to 1.98	V	—
Enhanced local bus I/O voltage		$BV_{DD}$	-0.3 to 3.63	V	—
Input voltage	DDR2/DDR3 DRAM signals	$MV_{IN}$	-0.3 to ( $GV_{DD} + 0.3$ )	V	2, 7
	DDR2/DDR3 DRAM reference	$MV_{REF}$	-0.3 to ( $GV_{DD}/2 + 0.3$ )	V	—
	Three-speed Ethernet signals	$LV_{IN}$	-0.3 to ( $LV_{DD} + 0.3$ )	V	3, 7
	Enhanced local bus signals	$BV_{IN}$	-0.3 to ( $BV_{DD} + 0.3$ )	—	5
	DUART, SYSCLK, system control and power management, I <sup>2</sup> C, clocking, I/O voltage select, and JTAG I/O voltage	$OV_{IN}$	-0.3 to ( $OV_{DD} + 0.3$ )	V	6, 7
	USB, eSPI, eSDHC	$CV_{IN}$	-0.3 to ( $CV_{DD} + 0.3$ )	V	4
	SerDes signals	$XV_{IN}$	-0.3 to ( $XV_{DD} + 0.3$ )	V	—

**Table 2. Absolute Maximum Ratings<sup>1</sup> (continued)**

Characteristic	Symbol	Max Value	Unit	Note
Storage temperature range	T <sub>STG</sub>	-55 to 150	°C	—

**Notes:**

- Functional operating conditions are given in [Table 3](#). Absolute maximum ratings are stress ratings only, and functional operation at the maximums is not guaranteed. Stresses beyond those listed may affect device reliability or cause permanent damage to the device.
- Caution: MVIN must not exceed GVDD by more than 0.3 V. This limit may be exceeded for a maximum of 20 ms during power-on reset and power-down sequences.
- Caution: LVIN must not exceed LVDD by more than 0.3 V. This limit may be exceeded for a maximum of 20 ms during power-on reset and power-down sequences.
- Caution: CVIN must not exceed CVDD by more than 0.3 V. This limit may be exceeded for a maximum of 20 ms during power-on reset and power-down sequences.
- Caution: BVIN must not exceed BVDD by more than 0.3 V. This limit may be exceeded for a maximum of 20 ms during power-on reset and power-down sequences.
- Caution: OVIN must not exceed OVDD by more than 0.3 V. This limit may be exceeded for a maximum of 20 ms during power-on reset and power-down sequences.
- (C,X,B,G,L,O)VIN and MV<sub>REF</sub> may overshoot/undershoot to a voltage and for a maximum duration as shown in [Figure 7](#).
- AV<sub>DD</sub> is measured at the input to the filter (as shown in AN4259) and not at the pin of the device.

## 2.1.2 Recommended Operating Conditions

This table provides the recommended operating conditions for this device. Note that the values in this table are the recommended and tested operating conditions. Proper device operation outside these conditions is not guaranteed.

**Table 3. Recommended Operating Conditions**

Characteristic	Symbol	Recommended Value	Unit	Notes
Core 0 and platform supply voltage	V <sub>DDC</sub>	1.0 ± 50 mV	V	1
PLL supply voltage	AV <sub>DD_CORE0</sub> AV <sub>DD_DDR</sub> AV <sub>DD_PLAT</sub> AV <sub>DD_SRDS</sub>	1.0 ± 50 mV	V	—
Core power supply for SerDes transceivers	SV <sub>DD_SRDS</sub>	1.0 ± 50 mV	V	—
Pad power supply for SerDes transceivers and PCI Express	XV <sub>DD_SRDS</sub>	1.0 ± 50 mV	V	—
DDR2 DRAM I/O voltage	GV <sub>DD</sub>	1.8 V ± 90 mV	V	—
DDR3 DRAM I/O voltage	GV <sub>DD</sub>	1.5 V ± 75 mV	—	—
Three-speed Ethernet I/O voltage (eTSEC)	LV <sub>DD</sub>	3.3 V ± 165 mV 2.5 V ± 125 mV	V	—
DUART, system control and power management, I <sup>2</sup> C, QUICC Engine block, and JTAG I/O voltage	OV <sub>DD</sub>	3.3 V ± 165 mV	V	—
Enhanced local bus I/O and QUICC Engine block voltage	BV <sub>DD</sub>	3.3 V ± 165 mV	V	—
USB, eSPI, eSDHC	CV <sub>DD</sub>	3.3 V ± 165 mV 2.5 V ± 125 mV 1.8 V ± 90 mV	V	—

**Table 3. Recommended Operating Conditions (continued)**

Characteristic		Symbol	Recommended Value	Unit	Notes
Input voltage	DDR2/3 DRAM signals	$MV_{IN}$	GND to $GV_{DD}$	V	—
	DDR2/3 DRAM reference	$MV_{REF}$	GND to $GV_{DD}/2$	V	—
	Three-speed Ethernet signals	$LV_{IN}$	GND to $LV_{DD}$	V	—
	Enhanced local bus signals	$BV_{IN}$	GND to $BV_{DD}$	V	—
	DUART, SYSCLK, system control and power management, I <sup>2</sup> C, and JTAG signals	$OV_{IN}$	GND to $OV_{DD}$	V	—
	USB, eSPI, eSDHC	$CV_{IN}$	GND to $CV_{DD}$	V	—
Junction temperature range		$T_A/T_J$	0 to 125 Commercial -40 to 125 Industrial	°C	3

**Notes:**

- Caution:** Until  $V_{DD}$  reaches its recommended operating voltage,  $V_{DD}$  may exceed  $L/C/B/G/OV_{DD}$  by up to 0.7 V. If 0.7 V is exceeded, extra current will be drawn by the device.
- Caution:** Until  $V_{DD}$  reaches its recommended operating voltage, if  $L/C/B/G/OV_{DD}$  exceeds  $V_{DD}$ , extra current may be drawn by the device.
- Min temp is specified with  $T_A$ ; Max temp is specified with  $T_J$ .

This figure shows the undershoot and overshoot voltages at the interfaces of the device.

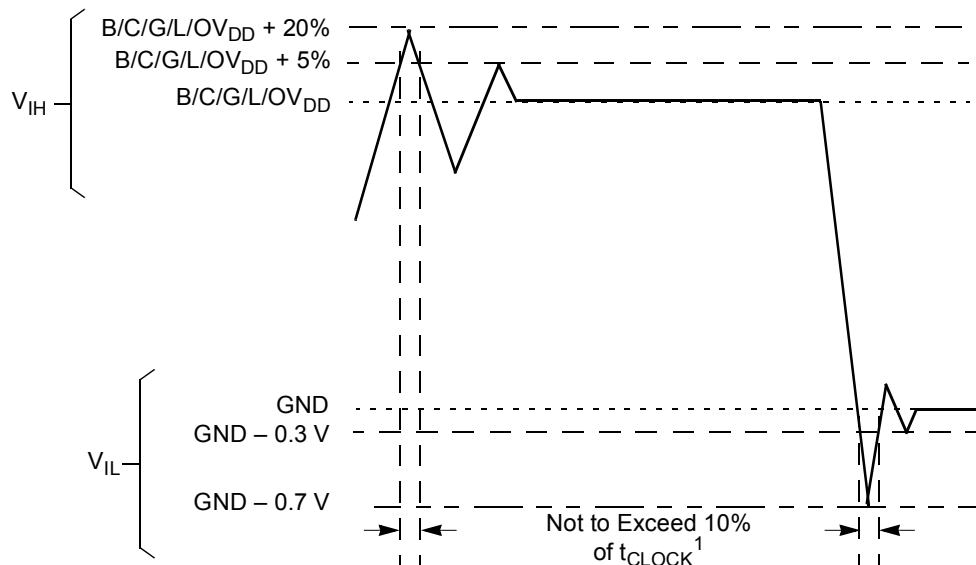
**Note:**

- $t_{CLOCK}$  refers to the clock period associated with the respective interface:  
 For I<sup>2</sup>C and JTAG,  $t_{CLOCK}$  references SYSCLK.  
 For DDR,  $t_{CLOCK}$  references MCK.  
 For eTSEC,  $t_{CLOCK}$  references EC\_GTX\_CLK125.  
 For eLBC,  $t_{CLOCK}$  references LCLK.

**Figure 7. Overshoot/Undershoot Voltage for  $BV_{DD}/CV_{DD}/GV_{DD}/LV_{DD}/OV_{DD}$** 

The core voltage must always be provided at nominal 1.0 V (see Table 3 for actual recommended core voltage). Voltage to the processor interface I/Os are provided through separate sets of supply pins and must be provided at the voltages shown in Table 3. The input voltage threshold scales with respect to the associated I/O supply voltage.  $OV_{DD}$  and  $LV_{DD}$  based receivers are simple CMOS I/O circuits and satisfy appropriate LVCMOS type specifications. The SDRAM interface uses a differential receiver

## Electrical Characteristics

referenced the externally supplied  $MV_{REF}$  signal (nominally set to  $GV_{DD}/2$ ). The DDR DQS receivers cannot be operated in single-ended fashion. The complement signal must be properly driven and cannot be grounded.

### 2.1.3 Output Driver Characteristics

This table provides information on the characteristics of the output driver strengths. The values are preliminary estimates.

**Table 4. Output Drive Capability**

Driver Type	Output Impedance ( $\Omega$ )	Supply Voltage	Notes
Enhanced local bus interface	45	$BV_{DD} = 3.3\text{ V}$	—
DDR2 signal (programmable)	18 (full-strength mode) 36 (half-strength mode)	$GV_{DD} = 1.8\text{ V}$	11
DDR 3 signal (programmable)	20 (full-strength mode) 40 (half-strength mode)	$GV_{DD} = 1.5\text{ V}$	1
TSEC signals	45	$LV_{DD} = 2.5/3.3\text{ V}$	—
DUART, system control, JTAG	45	$OV_{DD} = 3.3\text{ V}$	—
I <sup>2</sup> C	45	$OV_{DD} = 3.3\text{ V}$	—
USB, SPI, eSDHC	45	$CV_{DD} = 3.3\text{ V}$ $CV_{DD} = 2.5\text{ V}$ $CV_{DD} = 1.8\text{ V}$	—

**Note:**

1. The drive strength of the DDR2/3 interface in half-strength mode is at  $T_j = 105^\circ\text{C}$  and at  $GV_{DD}$  (min)

## 2.2 Power Sequencing

The processor requires that its power rails be applied in a specific sequence in order to ensure proper device operation. These requirements are as follows for power up:

1.  $V_{DD}$ ,  $V_{DDC}$ ,  $AV_{DD}$ ,  $BV_{DD}$ ,  $LV_{DD}$ ,  $CV_{DD}$ ,  $OV_{DD}$ ,  $SV_{DD\_SRDS}$  and,  $XV_{DD\_SRDS}$
2.  $GV_{DD}$

All supplies must be at their stable values within 50 ms.

Items on the same line have no ordering requirement with respect to one another. Items on separate lines must be ordered sequentially such that voltage rails on a previous step must reach 90% of their value before the voltage rails on the current step reach 10% of theirs.

To guarantee MCKE low during power-up, the above sequencing for  $GV_{DD}$  is required. If there is no concern about any of the DDR signals being in an indeterminate state during power-up, the sequencing for  $GV_{DD}$  is not required.

### NOTE

From a system standpoint, if any of the I/O power supplies ramp prior to the  $V_{DD}$  core supply, the I/Os associated with that I/O supply may drive a logic one or zero during power-up, and extra current may be drawn by the device.

## 2.3 Power Down Requirements

The power-down cycle must complete such that power supply values are below 0.4 V before a new power-up cycle can be started.

## 2.4 RESET Initialization

This section describes the AC electrical specifications for the RESET initialization timing requirements. This table provides the RESET initialization AC timing specifications for the DDR SDRAM component(s).

**Table 5. RESET Initialization Timing Specifications**

Parameter/Condition	Min	Max	Unit	Note
Required assertion time of $\overline{\text{HRESET}}$	25	—	$\mu\text{s}$	1, 2
Minimum assertion time of $\overline{\text{TRESET}}$ simultaneous to HRESET assertion	25	—	ns	3
Maximum rise/fall time of $\overline{\text{HRESET}}$ —		1	SYSCLK	—
Minimum assertion time for $\overline{\text{SRESET}}$	3	—	SYSCLKs	4
Input setup time for POR configs (other than PLL config) with respect to negation of $\overline{\text{HRESET}}$	4	—	SYSCLKs	4
Input hold time for all POR configs (including PLL config) with respect to negation of $\overline{\text{HRESET}}$	2	—	SYSCLKs	4
Maximum valid-to-high impedance time for actively driven POR configs with respect to negation of $\overline{\text{HRESET}}$	—	5	SYSCLKs	4

**Notes:**

1. There may be some extra current leakage when driving signals high during this time.
2. Reset assertion timing requirements for DDR3 DRAMs may differ.
3. TRST is an asynchronous level sensitive signal. For guidance on how this requirement can be met, refer to the JTAG signal termination guidelines in AN4259.
4. SYSCLK is the primary clock input for the processor.

This table provides the PLL lock times.

**Table 6. PLL Lock Times**

Parameter/Condition	Min	Max	Unit	Notes
PLL lock times	—	100	$\mu\text{s}$	—

## 2.5 Power-on Ramp Rate

This section describes the AC electrical specifications for the power-on ramp rate requirements. Controlling the maximum power-on ramp rate is required to avoid falsely triggering the ESD circuitry. This table provides the power supply ramp rate specifications.

**Table 7. Power Supply Ramp Rate**

Parameter	Min	Max	Unit	Notes
Required ramp rate for all voltage supplies (including OVDD/CVDD/GVDD/BVDD/SVDD/LVDD, All VDD supplies, MVREF and all AVDD supplies.)	—	36000	V/s	1, 2

**Note:**

1. Ramp rate is specified as a linear ramp from 10 to 90%. If non-linear (for example. exponential), the maximum rate of change from 200 to 500 mV is the most critical as this range might falsely trigger the ESD circuitry.
2. Over full recommended operating temperature range (see [Table 3](#)).

## 2.6 Power Characteristics

The core power dissipation for the core complex bus (CCB) versus the core frequency for this family of QorIQ devices is shown in this table.

**Table 8. Core Power Dissipation**

Core Frequency (MHz)	Platform Frequency (MHz)	V <sub>DD</sub> (V)	Power Mode	Junction Temperature (°C)	Power (W)	Notes
533	266	1	Typical	65	1.42	1, 2, 3
				105	2.25	1, 4, 5
			Maximum	125	2.47	1, 4, 5
				105	2.36	1, 5, 6, 7
				125	2.5	1, 5, 6, 7
				125	2.63	1, 5, 6, 7
667	333	1	Typical	65	1.53	1, 2, 3
				105	2.36	1, 4, 5
			Maximum	125	2.58	1, 4, 5
				105	2.4	1, 5, 6, 7
				125	2.63	1, 5, 6, 7
				125	2.63	1, 5, 6, 7

Table 8. Core Power Dissipation (continued)

Core Frequency (MHz)	Platform Frequency (MHz)	V <sub>DD</sub> (V)	Power Mode	Junction Temperature (°C)	Power (W)	Notes
800	400	1	Typical	65	1.64	1, 2, 3
			Thermal	105	2.47	1, 4, 5
				125	2.69	1, 4, 5
			Maximum	105	2.52	1, 5, 6, 7
				125	2.75	1, 5, 6, 7

**Note:**

1. Combined power of V<sub>DD</sub>, V<sub>DDC</sub>, and AV<sub>DD\_n</sub> with DDR controller/s and all SerDes banks active. Does not include I/O power.
2. Typical power assumes Dhrystone running with activity factor of 80% (on all cores) and executing DMA on the platform with 90% activity factor.
3. Typical power based on nominal processed device.
4. Thermal power assumes Dhrystone running with activity factor of 80% (on all cores) and executing DMA on the platform at 90% activity factor.
5. Thermal and maximum power are based on worst case processed device.
6. Maximum power assumes Dhrystone running with activity factor at 100% (on all cores) and executing DMA on the platform at 100% activity factor.
7. Maximum power provided for power supply design sizing.

## 2.6.1 I/O DC Power Supply Recommendation

This table provides estimated I/O power numbers for each block: DDR, PCIe, eLBC, eTSEC, SGMII, eSDHC, USB, eSPI, DUART, I<sup>2</sup>C, and GPIO.

Table 9. I/O Power Supply Estimated Values

Interface	Parameter	Symbol	Typical	Unit	Notes
DDR3 75% utilization	600 MHz data rate	GV <sub>DD</sub> (1.5 V)	0.76	W	1, 2
	667 MHz data rate	GV <sub>DD</sub> (1.5 V)	0.82	W	1, 2
DDR3 40% utilization	600 MHz data rate	GV <sub>DD</sub> (1.5 V)	0.57	W	1, 2
	667 MHz data rate	GV <sub>DD</sub> (1.5 V)	0.63	W	1, 2
PCI Express	×1, 2.5 G-baud	X/SV <sub>DD</sub> (1.0 V)	0.11	W	1
	×2, 2.5 G-baud	X/SV <sub>DD</sub> (1.0 V)	0.15	W	1
	×4, 2.5 G-baud	X/SV <sub>DD</sub> (1.0 V)	0.229	W	1
SGMII	×1, 1.25G-baud	X/SV <sub>DD</sub> (1.0 V)	0.096	W	1
eLBC	16-bit, 83MHz	BV <sub>DD</sub> (1.8 V)	0.017	W	1, 3
		BV <sub>DD</sub> (2.5 V)	0.03	W	1, 3
		BV <sub>DD</sub> (3.3 V)	0.047	W	1, 3
eTSEC	RGMII	LV <sub>DD</sub> (2.5 V)	0.075	W	1, 3, 4
		LV <sub>DD</sub> (3.3 V)	0.124	W	1, 3, 4

**Table 9. I/O Power Supply Estimated Values (continued)**

Interface	Parameter	Symbol	Typical	Unit	Notes
eSDHC	—	$CV_{DD}$ (1.8 V)	0.005	W	1, 3
		$CV_{DD}$ (2.5 V)	0.009	W	1, 3
		$CV_{DD}$ (3.3 V)	0.014	W	1, 3
USB —	—	$CV_{DD}$ (1.8 V)	0.004	W	1, 3
		$CV_{DD}$ (2.5 V)	0.008	W	1, 3
		$CV_{DD}$ (3.3 V)	0.012	W	1, 3
eSPI	—	$CV_{DD}$ (1.8 V)	0.004	W	1, 3
		$CV_{DD}$ (2.5 V)	0.006	W	1, 3
		$CV_{DD}$ (3.3 V)	0.01	W	1, 3
I <sup>2</sup> C	—	$OV_{DD}$ (3.3 V)	0.002	W	1, 3
DUART	—	$OV_{DD}$ (3.3 V)	0.006	W	1, 3
IEEE1588	—	$LV_{DD}$ (2.5 V)	0.004	W	1, 3
		$LV_{DD}$ (3.3 V)	0.007	W	1, 3
QUICC Engine block (UTOPIA) L2	—	$BV_{DD}$ (3.3 V)	0.08	W	1, 3

**Notes:**

1. The typical values are estimates based on simulations 65 C junction temperature.
2. DDR power numbers are based on 2 rank DIMM.
3. Assuming 15 pF total capacitance load per pin.
4. The current values are per each eTSEC used.
5. GPIO ×8 support on OVDD and ×8 on BVDD rail supply.

## 2.7 Input Clocks

This section discusses the system clock timing, SYSCLK and spread spectrum sources, real time clock timing, eTSEC Gigabit reference clock timing, DDR clock timing, and other input clocks.

**NOTE:**

The rise / fall time on QE input pins should not exceed 5ns. This should be enforced especially on clock signals. Rise time refers to signal transitions from 10% to 90% of Vcc; fall time refers to transitions from 90% to 10% of Vcc.



## 2.7.1 System Clock Timing

This table provides the system clock (SYSCLK) DC specifications.

**Table 10. SYSCLK DC Electrical Characteristics**

At recommended operating conditions with  $OV_{DD} = 3.3 \text{ V} \pm 165 \text{ mV}$

Parameter	Symbol	Min	Typical	Max	Unit	Notes
Input high voltage	$V_{IH}$	2.0	—		V	1
Input low voltage	$V_{IL}$	—	—	0.8	V	1
Input capacitance	$C_{IN}$	—	7	15	pf	—
Input current ( $V_{IN} = 0 \text{ V}$ or $V_{IN} = V_{DD}$ )	$I_{IN}$	—	—	$\pm 50$	$\mu\text{A}$	2

**Note:**

1. The max  $V_{IH}$ , and min  $V_{IL}$  values can be found in [Table 3](#).
2. The symbol  $V_{IN}$ , in this case, represents the  $OV_{IN}$  symbol referenced in [Table 3](#).

This table provides the system clock (SYSCLK) AC timing specifications.

**Table 11. SYSCLK AC Timing Specifications**

At recommended operating conditions (see [Table 3](#)) with  $OV_{DD} = 3.3 \text{ V} \pm 165 \text{ mV}$

Parameter/Condition	Symbol	Min	Typical	Max	Unit	Notes
SYSCLK frequency	$f_{\text{SYSCLK}}$	64	—	100	MHz	1
SYSCLK cycle time	$t_{\text{SYSCLK}}$	10	—	15	ns	—
SYSCLK duty cycle	$t_{\text{KHK}}/t_{\text{SYSCLK}}$	40	—	60	%	2
SYSCLK slew rate	—	1	—	4	V/ns	3
SYSCLK peak period jitter	—	—	—	$\pm 150$	ps	—
SYSCLK jitter phase noise at $-56\text{dBc}$	—	—	—	500	KHz	4
AC Input Swing Limits at $3.3 \text{ V } OV_{DD}$	$\Delta V_{AC}$	1.9	—	—	V	—

**Notes:**

1. **Caution:** The CCB\_clk to SYSCLK ratio and e500 core to CCB\_clk ratio settings must be chosen such that the resulting SYSCLK frequency, e500 core frequency, and CCB\_clk frequency do not exceed their respective maximum or minimum operating frequencies. Refer to for ratio settings.
2. Measured at the rising edge and/or the falling edge at  $OV_{DD}/2$ .
3. Slew rate as measured from  $\pm 0.3 \Delta V_{AC}$  at center of peak to peak voltage at clock input.
4. Phase noise is calculated as FFT of TIE jitter.

## 2.7.2 SYSCLK and Spread Spectrum Sources

Spread spectrum clock sources are an increasingly popular way to control electromagnetic interference emissions (EMI) by spreading the emitted noise to a wider spectrum and reducing the peak noise magnitude in order to meet industry and government requirements. These clock sources intentionally add long-term jitter in order to diffuse the EMI spectral content. The jitter specification given in [Table 12](#) considers short-term (cycle-to-cycle) jitter only and the clock generator's cycle-to-cycle output jitter should meet the processor's input cycle-to-cycle jitter requirement. Frequency modulation and spread are separate concerns, and the P1012 is compatible with spread spectrum sources if the recommendations listed in this table are observed.

**Table 12. Spread Spectrum Clock Source Recommendations**

 At recommended operating conditions. See [Table 3](#).

Parameter	Min	Max	Unit	Notes
Frequency modulation	—	60	kHz	—
Frequency spread	—	1.0	%	1, 2

**Note:**

1. SYSCLK frequencies resulting from frequency spreading, and the resulting core and VCO frequencies, must meet the minimum and maximum specifications given in [Table 11](#).
2. Maximum spread spectrum frequency may not result in exceeding any maximum operating frequency of the device.

### CAUTION

The processor's minimum and maximum SYSCLK, DDRCLK, core, and VCO frequencies must not be exceeded regardless of the type of clock source. Therefore, systems in which the processor is operated at its maximum rated e500 core/DDR memory frequency should avoid violating the stated limits by using down-spreading only.

## 2.7.3 Real Time Clock Timing

The real time clock timing (RTC) input is sampled by the platform clock (CCB clock). The output of the sampling latch is then used as an input to the counters of the PIC and the TimeBase unit of the e500. There is no jitter specification. The minimum pulse width of the RTC signal should be greater than  $2 \times$  the period of the CCB clock. That is, minimum clock high time is  $2 \times t_{CCB}$ , and minimum clock low time is  $2 \times t_{CCB}$ . There is no minimum RTC frequency; RTC may be grounded if not needed.

## 2.7.4 eTSEC Gigabit Reference Clock Timing

This table lists the eTSEC gigabit reference clock DC electrical characteristics.

**Table 13. eTSEC Gigabit Reference Clock DC Electrical Characteristics**

Parameter	Symbol	Min	Max	Unit	Notes
High-level input voltage	$V_{IH}$	2	—	V	1
Low-level input voltage	$V_{IL}$	—	0.8	V	1
Input current ( $V_{IN} = 0$ V or $V_{IN} = V_{DD}$ )	$I_{IN}$	—	$\pm 40$	$\mu$ A	2

**Note:**

1. The max  $V_{IH}$ , and min  $V_{IL}$  values can be found in [Table 3](#).
2. The symbol  $V_{IN}$ , in this case, represents the  $OV_{IN}$  symbol referenced in [Table 3](#).

This table provides the eTSEC gigabit reference clocks (EC\_GTX\_CLK125) AC timing specifications.

**Table 14. EC\_GTX\_CLK125 AC Timing Specifications**

 At recommended operating conditions with  $LV_{DD} = 2.5 \pm 0.125$  mV/  $3.3$  V  $\pm 165$  mV

Parameter/Condition	Symbol	Min	Typical	Max	Unit	Notes
EC_GTX_CLK125 frequency	$t_{G125}$	—	125	—	MHz	—
EC_GTX_CLK125 cycle time	$t_{G125}$	—	8	—	ns	—

**Table 14. EC\_GTX\_CLK125 AC Timing Specifications**

 At recommended operating conditions with  $V_{DD} = 2.5 \pm 0.125 \text{ mV} / 3.3 \text{ V} \pm 165 \text{ mV}$  (continued)

Parameter/Condition	Symbol	Min	Typical	Max	Unit	Notes
EC_GTX_CLK rise and fall time $V_{DD} = 2.5 \text{ V}$ $V_{DD} = 3.3 \text{ V}$	$t_{G125R}/t_{G125F}$	—	—	0.75 1.0	ns	1
EC_GTX_CLK125 duty cycle 1000Base-T for RGMII	$t_{G125H}/t_{G125}$	47	—	53	%	2
EC_GTX_CLK125 jitter	—	—	—	$\pm 150$	ps	2

**Notes:**

- Rise and fall times for EC\_GTX\_CLK125 are measured from 0.5 and 2.0 V for  $V_{DD} = 2.5 \text{ V}$  and from 0.6 and 2.7 V for  $V_{DD} = 3.3 \text{ V}$ .
- EC\_GTX\_CLK125 is used to generate the GTX clock for the eTSEC transmitter with 2% degradation. EC\_GTX\_CLK125 duty cycle can be loosened from 47/53% as long as the PHY device can tolerate the duty cycle generated by the eTSEC GTX\_CLK. See [Section 2.11.3.2, "RGMII AC Timing Specifications,"](#) for duty cycle for 10Base-T and 100Base-T reference clock.

## 2.7.5 DDR Clock Timing

This table provides the system clock (DDRCLK) DC specifications.

**Table 15. DDRCLK DC Electrical Characteristics**

 At recommended operating conditions with  $OV_{DD} = 3.3 \text{ V} \pm 165 \text{ mV}$ 

Parameter	Symbol	Min	Typical	Max	Unit	Notes
Input high voltage	$V_{IH}$	2.0	—	$OV_{DD} + 0.3$	V	1
Input low voltage	$V_{IL}$	-0.3	—	0.8	V	1
Input capacitance	$C_{IN}$	—	7	15	pf	—
Input current ( $V_{IN} = 0 \text{ V}$ or $V_{IN} = V_{DD}$ )	$I_{IN}$	—	—	$\pm 50$	$\mu\text{A}$	2

**Note:**

- The symbol  $V_{IN}$ , in this case, represents the  $OV_{IN}$  symbol referenced in [Table 2](#) and [Table 3](#).

This table provides the DDR clock (DDRCLK) AC timing specification.

**Table 16. DDRCLK AC Timing Specifications**

 At recommended operating conditions with  $OV_{DD}$  of  $3.3 \text{ V} \pm 5\%$ .

Parameter/Condition	Symbol	Min	Typical	Max	Unit	Notes
DDRCLK frequency	$f_{DDRCLK}$	66.66	—	166.7	MHz	1, 2
DDRCLK cycle time	$t_{DDRCLK}$	6	—	15	ns	1, 2
DDRCLK duty cycle	$t_{KHK}/t_{DDRCLK}$	40	—	60	%	2
DDRCLK slew rate	—	1	—	4	V/ns	3
DDRCLK peak period jitter	—	—	—	$\pm 150$	ps	—
DDRCLK jitter phase noise at -56dBc	—	—	—	500	KHz	4

## Electrical Characteristics

**Table 16. DDRCLK AC Timing Specifications (continued)**

At recommended operating conditions with  $OV_{DD}$  of 3.3 V  $\pm$  5%.

Parameter/Condition	Symbol	Min	Typical	Max	Unit	Notes
AC Input Swing Limits at 3.3 V $OV_{DD}$	$\Delta V_{AC}$	1.9	—	—	V	—

**Notes:**

1. **Caution:** The DDR complex clock to DDRCLK ratio settings must be chosen such that the resulting DDR complex clock frequency does not exceed the maximum or minimum operating frequencies. Refer to *P1021 QorIQ Integrated Processor Reference Manual* for ratio settings.
2. Measured at the rising edge and/or the falling edge at  $OV_{DD}/2$ .
3. Slew rate as measured from  $\pm 0.3 \Delta V_{AC}$  at center of peak to peak voltage at clock input.
4. Phase noise is calculated as FFT of TIE jitter.

## 2.7.6 Other Input Clocks

A description of the overall clocking of this device is available in the *QorIQ P1021 Integrated Host Processor Family Reference Manual* in the form of a clock subsystem block diagram. For information on the input clocks of other functional blocks of the platform, such as SerDes and eTSEC, see the specific section of this document.

## 2.8 DDR2 and DDR3 SDRAM

This section describes the DC and AC electrical specifications for the DDR SDRAM interface. Note that the required  $GV_{DD}(\text{typ})$  voltage is 1.8 V or 1.5 V when interfacing to DDR2 or DDR3 SDRAM respectively.

### 2.8.1 DDR SDRAM DC Electrical Characteristics

This table provides the recommended operating conditions for the DDR SDRAM component(s) when interfacing to DDR2 SDRAM.

**Table 17. DDR2 SDRAM Interface DC Electrical Characteristics**

At recommended operating condition with  $GV_{DD} = 1.8$  V1

Parameter	Symbol	Min	Max	Unit	Notes
I/O reference voltage	$MV_{REF}$	$0.49 \times GV_{DD}$	$0.51 \times GV_{DD}$	V	2, 3, 4
Input high voltage	$V_{IH}$	$MV_{REF} + 0.125$	—	V	5
Input low voltage	$V_{IL}$	—	$MV_{REF} - 0.125$	V	5

**Table 17. DDR2 SDRAM Interface DC Electrical Characteristics (continued)**

 At recommended operating condition with  $GV_{DD} = 1.8\text{ V}$ 

Parameter	Symbol	Min	Max	Unit	Notes
Output high current ( $V_{OUT} = 1.37\text{ V}$ )	$I_{OH}$	-13.4	—	mA	6
Output low current ( $V_{OUT} = 0.330\text{ V}$ ) I	$I_{OL}$	13.4	—	mA	6
I/O leakage current	$I_{OZ}$	-50	50	$\mu\text{A}$	7

**Notes:**

- $GV_{DD}$  is expected to be within 50 mV of the DRAM's voltage supply at all times. The DRAM's and memory controller's voltage supply may or may not be from the same source.
- $MV_{REF}$  is expected to be equal to  $0.5 \times GV_{DD}$  and to track  $GV_{DD}$  DC variations as measured at the receiver. Peak-to-peak noise on  $MV_{REF}$  may not exceed  $\pm 2\%$  of the DC value.
- $V_{TT}$  is not applied directly to the device. It is the supply to which far end signal termination is made, and it is expected to be equal to  $MV_{REF}$  with a min value of  $MV_{REF} - 0.04$  and a max value of  $MV_{REF} + 0.04$ .  $V_{TT}$  should track variations in the DC level of  $MV_{REF}$ .
- The voltage regulator for  $MV_{REF}$  must be able to supply up to 1500  $\mu\text{A}$ .
- Input capacitance load for DQ, DQS, and  $\overline{\text{DQS}}$  are available in the IBIS models.
- Refer to the IBIS model for the complete output IV curve characteristics.
- Output leakage is measured with all outputs disabled,  $0\text{ V} \leq V_{OUT} \leq GV_{DD}$ .

## Electrical Characteristics

This table provides the recommended operating conditions for the DDR SDRAM controller when interfacing to DDR3 SDRAM.

**Table 18. DDR3 SDRAM Interface DC Electrical Characteristics**

At recommended operating condition with  $GV_{DD} = 1.5\text{ V}^1$

Parameter	Symbol	Min	Max	Unit	Note
I/O reference voltage	$MV_{REF}$	$0.49 \times GV_{DD}$	$0.51 \times GV_{DD}$	V	2, 3, 4
Input high voltage	$V_{IH}$	$MV_{REF} + 0.100$	$GV_{DD}$	V	5
Input low voltage	$V_{IL}$	GND	$MV_{REF} - 0.100$	V	5
I/O leakage current	$I_{OZ}$	-50	50	$\mu\text{A}$	6

### Notes:

- $GV_{DD}$  is expected to be within 50 mV of the DRAM's voltage supply at all times. The DRAMs and memory controller's voltage supply may or may not be from the same source.
- $MV_{REFn}$  is expected to be equal to  $0.5 \times GV_{DD}$  and to track  $GV_{DD}$  DC variations as measured at the receiver. Peak-to-peak noise on  $MV_{REFn}$  may not exceed the  $MV_{REFn}$  DC level by more than  $\pm 1\%$  of  $GV_{DD}$  (i.e.  $\pm 15\text{ mV}$ ).
- $V_{TT}$  is not applied directly to the device. It is the supply to which far end signal termination is made, and it is expected to be equal to  $MV_{REFn}$  with a min value of  $MV_{REFn} - 0.04$  and a max value of  $MV_{REFn} + 0.04$ .  $V_{TT}$  should track variations in the DC level of  $MV_{REFn}$ .
- The voltage regulator for  $MV_{REFn}$  must meet the specifications stated in Table 20.
- Input capacitance load for DQ, DQS, and  $\overline{DQS}$  are available in the IBIS models.
- Output leakage is measured with all outputs disabled,  $0\text{ V} \leq V_{OUT} \leq GV_{DD}$ .

This table provides the DDR controller interface capacitance for DDR2 and DDR3.

**Table 19. DDR2 DDR3 SDRAM Capacitance**

At recommended operating conditions with  $GV_{DD}$  of  $1.8\text{ V} \pm 5\%$  for DDR2 or  $1.5\text{ V} \pm 5\%$  for DDR3

Parameter	Symbol	Min	Max	Unit	Notes
Input/output capacitance: DQ, DQS, $\overline{DQS}$	$C_{IO}$	6	8	pF	1, 2
Delta input/output capacitance: DQ, DQS, $\overline{DQS}$	$C_{DIO}$	—	0.5	pF	1, 2

### Note:

- This parameter is sampled.  $GV_{DD} = 1.8\text{ V} \pm 0.1\text{ V}$  (for DDR2),  $f = 1\text{ MHz}$ ,  $T_A = 25^\circ\text{C}$ ,  $V_{OUT} = GV_{DD}/2$ ,  $V_{OUT}$  (peak-to-peak) = 0.2 V.
- This parameter is sampled.  $GV_{DD} = 1.5\text{ V} \pm 0.075\text{ V}$  (for DDR3),  $f = 1\text{ MHz}$ ,  $T_A = 25^\circ\text{C}$ ,  $V_{OUT} = GV_{DD}/2$ ,  $V_{OUT}$  (peak-to-peak) = 0.175 V.

This table provides the current draw characteristics for  $MV_{REF}$ .

**Table 20. Current Draw Characteristics for  $MV_{REF}$**

For recommended operating conditions, see Table 3.

Parameter	Symbol	Min	Max	Unit	Notes
Current draw for DDR2 SDRAM for $MV_{REF}$	$MV_{REF}$ —		1500	$\mu\text{A}$	—
Current draw for DDR3 SDRAM for $MV_{REF}$	$MV_{REF}$ —		1250	$\mu\text{A}$	—

## 2.8.2 DDR2 and DDR3 SDRAM Interface AC Timing Specifications

This section provides the AC timing specifications for the DDR SDRAM controller interface. The DDR controller supports both DDR2 and DDR3 memories. Note that the required  $GV_{DD}(typ)$  voltage is 1.8 V or 1.5 V when interfacing to DDR2 or DDR3 SDRAM respectively.

### 2.8.2.1 DDR2 and DDR3 SDRAM Interface Input AC Timing Specifications

This table provides the input AC timing specifications for the DDR controller when interfacing to DDR2 SDRAM.

**Table 21. DDR2 SDRAM Interface Input AC Timing Specifications**

At recommended operating conditions with  $GV_{DD}$  of 1.8 V  $\pm$  5%

Parameter		Symbol	Min	Max	Unit	Notes
AC input low voltage	$\geq$ 667 MHz data rate	$V_{ILAC}$	—	$MV_{REF} - 0.20$	V	—
	$\leq$ 533 MHz data rate		—	$MV_{REF} - 0.25$		
AC input high voltage	$\geq$ 667 MHz data rate	$V_{IHAC}$	$MV_{REF} + 0.20$	—	V	—
	$\leq$ 533 MHz data rate		$MV_{REF} + 0.25$	—		

This table provides the input AC timing specifications for the DDR controller when interfacing to DDR3 SDRAM.

**Table 22. DDR3 SDRAM Interface Input AC Timing Specifications**

At recommended operating conditions with  $GV_{DD}$  of 1.5 V  $\pm$  5%

Parameter	Symbol	Min	Max	Unit	Notes
AC input low voltage	$V_{ILAC}$	—	$MV_{REF} - 0.175$	V	—
AC input high voltage	$V_{IHAC}$	$MV_{REF} + 0.175$	—	V	—

This table provides the input AC timing specifications for the DDR controller when interfacing to DDR2 and DDR3 SDRAM.

**Table 23. DDR2 and DDR3 SDRAM Interface Input AC Timing Specifications**

At recommended operating conditions with  $GV_{DD}$  of 1.8 V  $\pm$  5% for DDR2 or 1.5 V  $\pm$  5% for DDR3

Parameter	Symbol	Min	Max	Unit	Notes
Controller Skew for MDQS—MDQ/MECC	$t_{CISKEW}$	—	—	ps	1
667 MHz data rate		–390	390		
533 MHz data rate		–450	450		
400 MHz data rate		–515	515		

## Electrical Characteristics

**Table 23. DDR2 and DDR3 SDRAM Interface Input AC Timing Specifications (continued)**

At recommended operating conditions with  $GV_{DD}$  of 1.8 V  $\pm$  5% for DDR2 or 1.5 V  $\pm$  5% for DDR3

Parameter	Symbol	Min	Max	Unit	Notes
Tolerated Skew for MDQS—MDQ/MECC	$t_{DISKEW}$	—	—	ps	3
667 MHz data rate		-360	360		
533 MHz data rate		-488	488		
400 MHz data rate		-733	733		

**Note:**

- $t_{CISKEW}$  represents the total amount of skew consumed by the controller between MDQS[n] and any corresponding bit that will be captured with MDQS[n]. This should be subtracted from the total timing budget.
- DDR3 only.
- The amount of skew that can be tolerated from MDQS to a corresponding MDQ signal is called  $t_{DISKEW}$ . This can be determined by the following equation:  $t_{DISKEW} = \pm(T \div 4 - \text{abs}(t_{CISKEW}))$  where T is the clock period and  $\text{abs}(t_{CISKEW})$  is the absolute value of  $t_{CISKEW}$ .

This figure shows the DDR2 and DDR3 SDRAM interface input timing diagram.

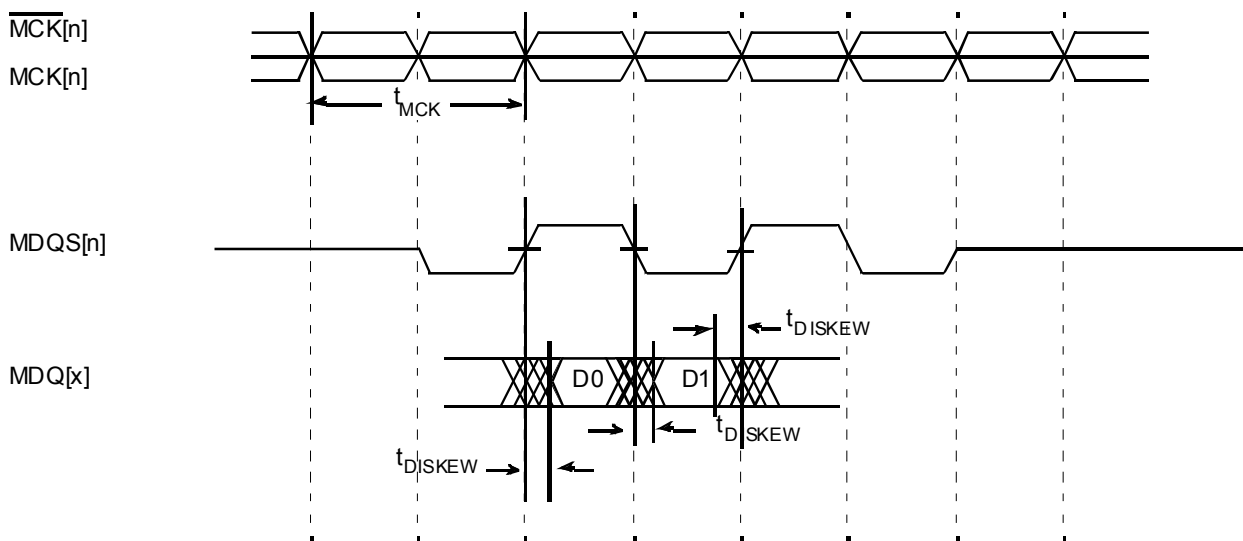

**Figure 8. DDR2 and DDR3 SDRAM Interface Input Timing Diagram**

### 2.8.2.2 DDR2 and DDR3 SDRAM Interface Output AC Timing Specifications

This table contains the output AC timing targets for the DDR2 and DDR3 SDRAM interface.

**Table 24. DDR2 and DDR3 SDRAM Interface Output AC Timing Specifications**

At recommended operating conditions with  $GV_{DD}$  of 1.8 V  $\pm$  5% for DDR2 or 1.5 V  $\pm$  5% for DDR3

Parameter	Symbol <sup>1</sup>	Min	Max	Unit	Notes
MCK[n] cycle time	$t_{MCK}$	3	5	ns	2



**Table 24. DDR2 and DDR3 SDRAM Interface Output AC Timing Specifications (continued)**

 At recommended operating conditions with  $GV_{DD}$  of 1.8 V  $\pm$  5% for DDR2 or 1.5 V  $\pm$  5% for DDR3

Parameter	Symbol <sup>1</sup>	Min	Max	Unit	Notes
ADDR/CMD output setup with respect to MCK 667 MHz data rate 533 MHz data rate 400 MHz data rate	$t_{DDKHAS}$	— .950 1.33 1.8	— — — —	ns	3
ADDR/CMD output hold with respect to MCK 667 MHz data rate 533 MHz data rate 400 MHz data rate	$t_{DDKHAX}$	— .950 1.33 1.8	— — — —	ns	3
$\overline{MCS}[n]$ output setup with respect to MCK 667 MHz data rate 533 MHz data rate 400 MHz data rate	$t_{DDKHCS}$	— .950 1.33 1.8	— — — —	ns	3
$\overline{MCS}[n]$ output hold with respect to MCK 667 MHz data rate 533 MHz data rate 400 MHz data rate	$t_{DDKH CX}$	— .950 1.33 1.8	— — — —	ns	3
MCK to MDQS Skew $\leq$ 667 MHz data rate	$t_{DDKMHM}$	— -0.6	— 0.6	ns	4

## Electrical Characteristics

**Table 24. DDR2 and DDR3 SDRAM Interface Output AC Timing Specifications (continued)**

At recommended operating conditions with  $GV_{DD}$  of  $1.8\text{ V} \pm 5\%$  for DDR2 or  $1.5\text{ V} \pm 5\%$  for DDR3

Parameter	Symbol <sup>1</sup>	Min	Max	Unit	Notes
MDQ/MECC/MDM output setup with respect to MDQS	$t_{DDKHDS}$ , $t_{DDKLDS}$	—	—	ps	5
667 MHz data rate		325	—		
533 MHz data rate		388	—		
400 MHz data rate		550	—		
MDQ/MECC/MDM output hold with respect to MDQS	$t_{DDKHDX}$ , $t_{DDKLDX}$	—	—	ps	5
667 MHz data rate		325	—		
533 MHz data rate		388	—		
400 MHz data rate		550	—		
MDQS preamble	$t_{DDKHMP}$	$0.9 \times t_{MCK}$	—	ns	—
MDQS postamble	$t_{DDKHME}$	$0.4 \times t_{MCK}$	$0.6 \times t_{MCK}$	ns	—

**Note:**

- The symbols used for timing specifications follow the pattern of  $t_{(\text{first two letters of functional block})(\text{signal})(\text{state})(\text{reference})(\text{state})}$  for inputs and  $t_{(\text{first two letters of functional block})(\text{reference})(\text{state})(\text{signal})(\text{state})}$  for outputs. Output hold time can be read as DDR timing (DD) from the rising or falling edge of the reference clock (KH or KL) until the output went invalid (AX or DX). For example,  $t_{DDKHAS}$  symbolizes DDR timing (DD) for the time  $t_{MCK}$  memory dock reference (K) goes from the high (H) state until outputs (A) are setup (S) or output valid time. Also,  $t_{DDKLDX}$  symbolizes DDR timing (DD) for the time  $t_{MCK}$  memory clock reference (K) goes low (L) until data outputs (D) are invalid (X) or data output hold time.
- All MCK/MCK and MCDQS/MCDQS referenced measurements are made from the crossing of the two signals.
- ADDR/CMD includes all DDR SDRAM output signals except MCK/MCK, MCS, and MDQ/MECC/MDM/MDQS.
- Note that  $t_{DDKHMH}$  follows the symbol conventions described in note 1. For example,  $t_{DDKHMH}$  describes the DDR timing (DD) from the rising edge of the MCK[n] clock (KH) until the MDQS signal is valid (MH).  $t_{DDKHMH}$  can be modified through control of the MDQS override bits (called WR\_DATA\_DELAY) in the TIMING\_CFG\_2 register. This is typically set to the same delay as in DDR\_SDRAM\_CLK\_CNTL[CLK\_ADJUST]. The timing parameters listed in the table assume that these two parameters have been set to the same adjustment value. See the *P1021 QorIQ Integrated Processor Reference Manual* for a description and explanation of the timing modifications enabled by use of these bits.
- Determined by maximum possible skew between a data strobe (MDQS) and any corresponding bit of data (MDQ), ECC (MECC), or data mask (MDM). The data strobe should be centered inside of the data eye at the pins of the microprocessor.

**NOTE**

For the ADDR/CMD setup and hold specifications in [Table 24](#), it is assumed that the clock control register is set to adjust the memory clocks by  $\frac{1}{2}$  applied cycle.

This figure shows the DDR2 and DDR3 SDRAM interface output timing for the MCK to MDQS skew measurement ( $t_{DDKMHM}$ ).

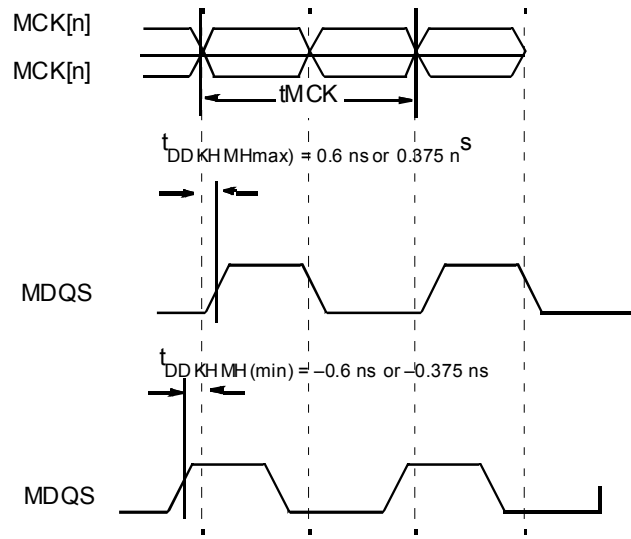

Figure 9.  $t_{DDKMHM}$  Timing Diagram

This figure shows the DDR2 and DDR3 SDRAM output timing diagram.

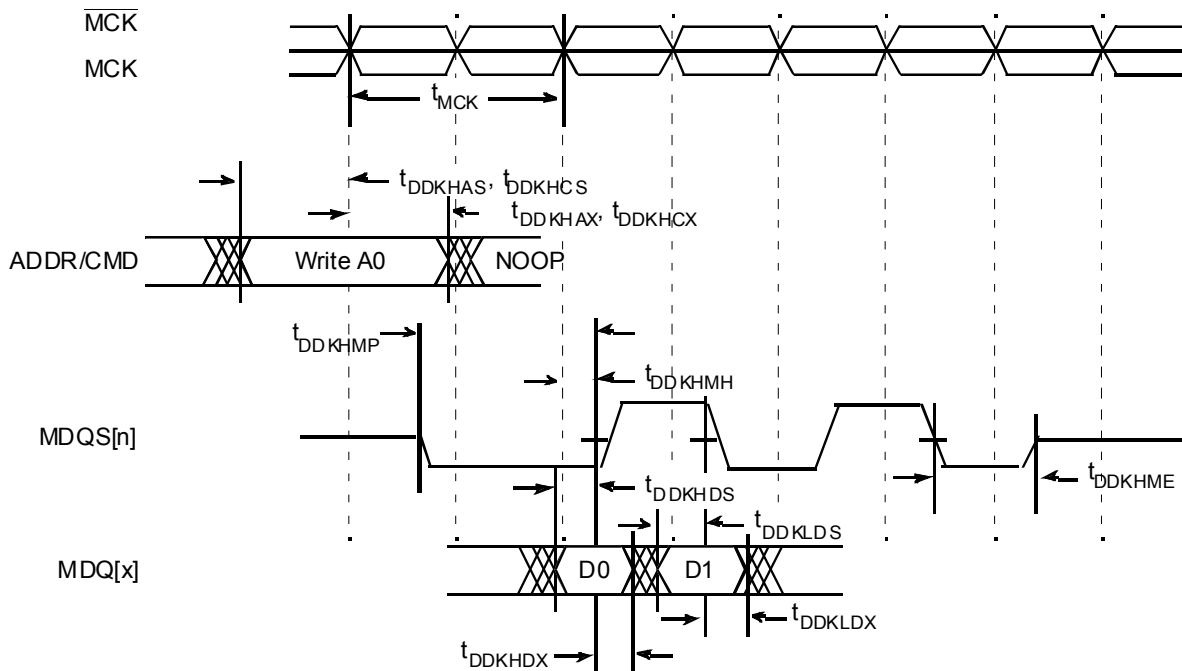

Figure 10. DDR2 and DDR3 Output Timing Diagram

## Electrical Characteristics

This figure provides the AC test load for the DDR2 and DDR3 controller bus.

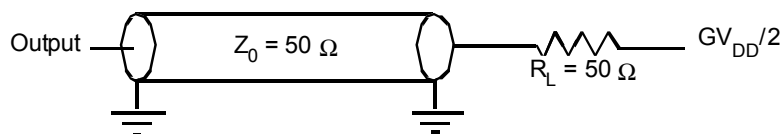

Figure 11. DDR2 and DDR3 Controller Bus AC Test Load

### 2.8.2.3 DDR2 and DDR3 SDRAM Differential Timing Specifications

This section describes the DC and AC differential timing specifications for the DDR2 and DDR3 SDRAM controller interface.

This figure shows the differential timing specification.

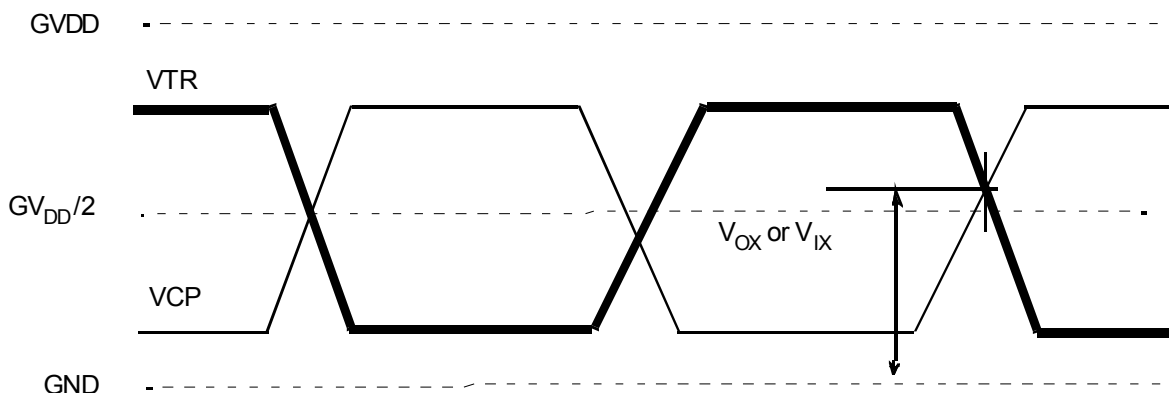

Figure 12. DDR2 and DDR3 SDRAM Differential Timing Specifications

#### NOTE

VTR specifies the true input signal (such as MCK or MDQS) and VCP is the complementary input signal (such as  $\overline{\text{MCK}}$  or  $\overline{\text{MDQS}}$ ).

This table provides the DDR2 differential specifications for the differential signals MDQS/ $\overline{\text{MDQS}}$  and MCK/ $\overline{\text{MCK}}$ .

Table 25. DDR2 SDRAM Differential Electrical Characteristics

Parameter	Symbol	Min	Max	Unit	Notes
Input AC Differential Crosspoint Voltage	$V_{IXAC}$	$0.5 \times GVDD - 0.175$	$0.5 \times GVDD + 0.175$	V	—
Output AC Differential Crosspoint Voltage	$V_{OXAC}$	$0.5 \times GVDD - 0.125$	$0.5 \times GVDD + 0.125$	V	—

This table provides the DDR3 differential specifications for the differential signals MDQS/ $\overline{\text{MDQS}}$  and MCK/ $\overline{\text{MCK}}$ .

Table 26. DDR3 SDRAM Differential Electrical Characteristics

Parameter	Symbol	Min	Max	Unit	Notes
Input AC Differential Crosspoint Voltage	$V_{IXAC}$	$0.5 \times GVDD - 0.150$	$0.5 \times GVDD + 0.150$	V	—
Output AC Differential Crosspoint Voltage	$V_{OXAC}$	$0.5 \times GVDD - 0.115$	$0.5 \times GVDD + 0.115$	V	—

## 2.9 eSPI

This section describes the DC and AC electrical specifications for the SPI interface.

### 2.9.1 eSPI DC Electrical Characteristics

This table provides the DC electrical characteristics for eSPI interface at  $CV_{DD} = 3.3\text{ V}$ .

**Table 27. SPI DC Electrical Characteristics (3.3V)**

For recommended operating conditions, see [Table 3](#).

Parameter	Symbol	Min	Max	Unit	Note
Input high voltage	$V_{IH}$	2.0	—	V	1
Input low voltage	$V_{IL}$	—	0.8	V	1
Input current ( $0\text{ V} \leq V_{IN} \leq CV_{DD}$ )	$I_{IN}$	—	$\pm 50$	$\mu\text{A}$	2
Output high voltage ( $I_{OH} = -6.0\text{ mA}$ )	$V_{OH}$	2.4	—	V	—
Output low voltage ( $I_{OL} = 6.0\text{ mA}$ )	$V_{OL}$	—	0.5	V	—
Output low voltage ( $I_{OL} = 3.2\text{ mA}$ )	$V_{OL}$	—	0.4	V	—

**Note:**

- Note that the min  $V_{IL}$  and max  $V_{IH}$  values are based on the respective min and max  $CV_{IN}$  values found in [Table 3](#).
- Note that the symbol  $V_{IN}$ , in this case, represents the  $CV_{IN}$  symbol referenced in [Section 2.1.2, "Recommended Operating Conditions."](#)

This table provides the DC electrical characteristics for the eSPI interface operating at  $CV_{DD} = 2.5\text{ V}$ .

**Table 28. SPI DC Electrical Characteristics (2.5 V)**

Parameter	Symbol	Min	Max	Unit	Note
High-level input voltage	$V_{IH}$	1.7	—	V	1
Low-level input voltage	$V_{IL}$	—	0.7	V	1
Input current ( $V_{IN} = 0\text{ V}$ or $V_{IN} = CV_{DD}$ )	$I_{IN}$	—	$\pm 40$	$\mu\text{A}$	2
High-level output voltage ( $CV_{DD} = \text{min}$ , $I_{OH} = -1\text{ mA}$ )	$V_{OH}$	2.0	—	V	—
Low-level output voltage ( $CV_{DD} = \text{min}$ , $I_{OL} = 1\text{ mA}$ )	$V_{OL}$	—	0.4	V	—

**Note:**

- The min  $V_{IL}$  and max  $V_{IH}$  values are based on the respective min and max  $CV_{IN}$  values found in [Table 3](#).
- The symbol  $V_{IN}$ , in this case, represents the  $CV_{IN}$  symbol referenced in [Section 2.1.2, "Recommended Operating Conditions."](#)

This table provides the DC electrical characteristics for the eSPI interface operating at  $CV_{DD} = 1.8\text{ V}$ .

**Table 29. SPI DC Electrical Characteristics (1.8 V)**

Parameter	Symbol	Min	Max	Unit	Note
High-level input voltage	$V_{IH}$	1.25	—	V	1
Low-level input voltage	$V_{IL}$	—	0.6	V	1

**Table 29. SPI DC Electrical Characteristics (1.8 V) (continued)**

Parameter	Symbol	Min	Max	Unit	Note
Input current ( $V_{IN} = 0\text{ V}$ or $V_{IN} = CV_{DD}$ )	$I_{IN}$	—	$\pm 40$	$\mu\text{A}$	2
High-level output voltage ( $CV_{DD} = \text{min}$ , $I_{OH} = -0.5\text{ mA}$ )	$V_{OH}$	1.35	—	V	—
Low-level output voltage ( $CV_{DD} = \text{min}$ , $I_{OL} = 0.5\text{ mA}$ )	$V_{OL}$	—	0.4	V	—

**Note:**

1. The min  $V_{IL}$  and max  $V_{IH}$  values are based on the respective min and max  $CV_{IN}$  values found in Table 3.
2. The symbol  $V_{IN}$ , in this case, represents the  $CV_{IN}$  symbol referenced in Section 2.1.2, "Recommended Operating Conditions."

## 2.9.2 eSPI AC Timing Specifications

This table provides the SPI input and output AC timing specifications.

**Table 30. SPI AC Timing Specifications<sup>1</sup>**

For recommended operating conditions, see Table 3.

Parameter	Symbol	Min	Max	Unit	Note
SPI outputs—Master data (internal clock) hold time	$t_{NIKH0X}$	$0.5 + (t_{PLAT}$ FOR M_CLK *SPMODE [HO _ADJ])	—	ns	2, 3
SPI outputs—Master data (internal clock) delay	$t_{NIKH0V}$	—	$5.5 + (t_{PLAT}$ FORM _CLK *SPMODE [HO _ADJ])	ns	2, 3
SPI_CS outputs—Master data (internal clock) hold time	$t_{NIKH0X2}$	0	—	ns	2
SPI_CS outputs—Master data (internal clock) delay	$t_{NIKH0V2}$	—	6.0	ns	2
SPI inputs—Master data (internal clock) input setup time	$t_{NIIVKH}$	5	—	ns	—
SPI inputs—Master data (internal clock) input hold time	$t_{NIIXKH}$	0	—	ns	—

**Notes:**

1. The symbols used for timing specifications follow the pattern of  $t_{(\text{first two letters of functional block})(\text{signal})(\text{state}) (\text{reference})(\text{state})}$  for inputs and  $t_{(\text{first two letters of functional block})(\text{reference})(\text{state})(\text{signal})(\text{state})}$  for outputs. For example,  $t_{NIKH0V}$  symbolizes the NMSI outputs internal timing (NI) for the time  $t_{SPI}$  memory clock reference (K) goes from the high state (H) until outputs (O) are valid (V).
2. Output specifications are measured from the 50% level of the rising edge of CLKIN to the 50% level of the signal. Timings are measured at the pin.
3. See the *P1021 QorIQ Integrated Processor Reference Manual* for detail about the register SPMODE

This figure provides the AC test load for the SPI.

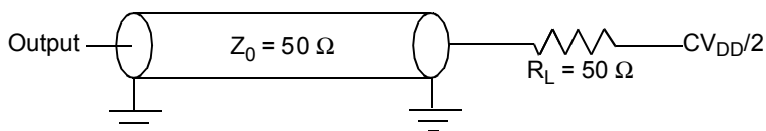

Figure 13. SPI AC Test Load

This figure represents the AC timing from Table 30 in master mode (internal clock). Note that although the specifications are generally refer to the rising edge of the clock, these AC timing diagrams also apply when the falling edge is the active edge. Also, note that the clock edge is selectable on SPI.

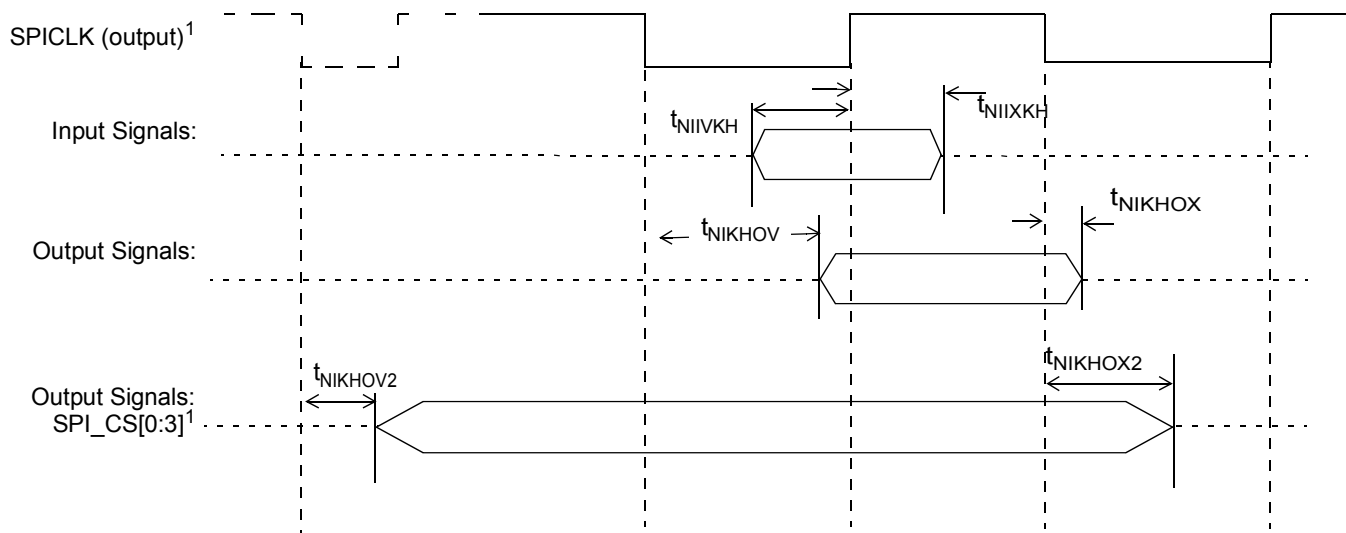

Figure 14. SPI AC Timing in Master Mode (Internal Clock) Diagram

## 2.10 DUART

This section describes the DC and AC electrical specifications for the DUART interface.

### 2.10.1 DUART DC Electrical Characteristics

This table provides the DC electrical characteristics for the DUART interface.

Table 31. DUART DC Electrical Characteristics

For recommended operating conditions, see Table 3

Parameter	Symbol	Min	Max	Unit	Notes
Input high voltage	$V_{IH}$	2	—	V	1
Input low voltage	$V_{IL}$	—	0.8	V	1
Input current ( $OV_{IN} = 0\text{ V}$ or $OV_{IN} = OV_{DD}$ )	$I_{IN}$	—	$\pm 50$	$\mu\text{A}$	2
Output high voltage ( $OV_{DD} = mn, I_{OH} = -2\text{ mA}$ )	$V_{OH}$	2.4	—	V	—

## Electrical Characteristics

**Table 31. DUART DC Electrical Characteristics**

For recommended operating conditions, see [Table 3](#)

Parameter	Symbol	Min	Max	Unit	Notes
Output low voltage ( $OV_{DD} = \text{min}$ , $I_{OL} = 2 \text{ mA}$ )	$V_{OL}$	—	0.4	V	—

**Note:**

- Note that the min  $V_{IL}$  and max  $V_{IH}$  values are based on the respective min and max  $OV_{IN}$  values found in [Figure 3](#).
- Note that the symbol  $OV_{IN}$  represents the input voltage of the supply. It is referenced in [Figure 3](#).

## 2.10.2 DUART AC Electrical Specifications

This table provides the AC timing parameters for the DUART interface.

**Table 32. DUART AC Timing Specifications**

Parameter	Value	Unit	Notes
Minimum baud rate	CCB clock/1,048,576	baud	1
Maximum baud rate	CCB clock/16	baud	2
Oversample rate	16	—	3

**Notes:**

- CCB clock refers to the platform clock.
- Actual attainable baud rate will be limited by the latency of interrupt processing.
- The middle of a start bit is detected as the 8<sup>th</sup> sampled 0 after the 1-to-0 transition of the start bit. Subsequent bit values are sampled each 16<sup>th</sup> sample.

## 2.11 Ethernet: Enhanced Three-Speed Ethernet (eTSEC) (10/100/1000 Mbps)—MII/RMII/RGMII/SGMII Electrical Characteristics

This section provides the AC and DC electrical characteristics for enhanced three-speed Ethernet 10/100/1000 controller and MII management.

### 2.11.1 MII Interface Electrical Specifications

This section provides AC and DC electrical characteristics of MII interface for eTSEC.



### 2.11.1.1 MII and RMII DC Electrical Characteristics

All MII drivers and receivers comply with the DC parametric attributes specified in this table.

**Table 33. MII and RMII DC Electrical Characteristics**

At recommended operating conditions with  $LV_{DD} = 3.3\text{ V}$

Parameter	Symbol	Min	Max	Unit	Notes
Input high voltage	$V_{IH}$	2.0	—	V	1
Input low voltage	$V_{IL}$	—	0.8	V	—
Input high current ( $V_{IN} = LV_{DD}$ )	$I_{IH}$	—	50	$\mu\text{A}$	2
Input low current ( $V_{IN} = \text{GND}$ )	$I_{IL}$	-50	—	$\mu\text{A}$	2
Output high voltage ( $LV_{DD} = \text{min}$ , $I_{OH} = -4.0\text{ mA}$ )	$V_{OH}$	2.4	—	V	—
Output low voltage ( $LV_{DD} = \text{min}$ , $I_{OL} = 4.0\text{ mA}$ )	$V_{OL}$	— 0	.4	V	—

**Note:**

1. The min  $V_{IL}$  and max  $V_{IH}$  values are based on the respective min and max  $LV_{IN}$  values found in [Table 3](#).
2. The symbol  $V_{IN}$ , in this case, represents the  $LV_{IN}$  symbols referenced in [Table 2](#) and [Table 3](#).

### 2.11.1.2 MII AC Timing Specifications

This section describes the MII transmit and receive AC timing specifications.

#### 2.11.1.2.1 MII Transmit AC Timing Specifications

This table provides the MII transmit AC timing specifications.

**Table 34. MII Transmit AC Timing Specifications**

For recommended operating conditions, see [Table 3](#).

Parameter	Symbol	Min	Typ	Max	Unit
TX_CLK clock period 10 Mbps	$t_{MTX}$	399.96	400	400.04	ns
TX_CLK clock period 100 Mbps	$t_{MTX}$	39.996	40	40.004	ns
TX_CLK duty cycle	$t_{MTXH}/t_{MTX}$	35	—	65	%
TX_CLK to MII data TXD[3:0], TX_ER, TX_EN delay	$t_{MTKHDX}$	1	5	15	ns
TX_CLK data clock rise (20%–80%)	$t_{MTXR}$	1.0	—	4.0	ns
TX_CLK data clock fall (80%–20%)	$t_{MTXF}$	1.0	—	4.0	ns

This figure shows the MII transmit AC timing diagram.

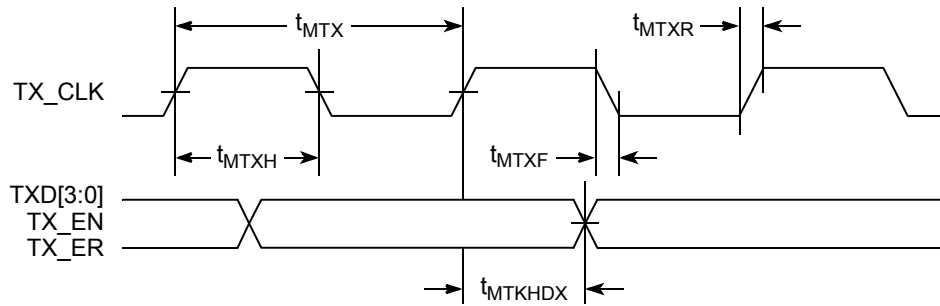

Figure 15. MII Transmit AC Timing Diagram

### 2.11.1.2.2 MII Receive AC Timing Specifications

This table provides the MII receive AC timing specifications.

Table 35. MII Receive AC Timing Specifications

Parameter	Symbol	Min	Typ	Max	Unit
RX_CLK clock period 10 Mbps	$t_{MRX}$	399.96	400	400.04	ns
RX_CLK clock period 100 Mbps	$t_{MRX}$	39.996	40	40.004	ns
RX_CLK duty cycle	$t_{MRXH}/t_{MRX}$	35	—	65	%
RXD[3:0], RX_DV, RX_ER setup time to RX_CLK	$t_{MRDVKH}$	10.0	—	—	ns
RXD[3:0], RX_DV, RX_ER hold time to RX_CLK	$t_{MRDXKH}$	10.0	—	—	ns
RX_CLK clock rise (20%–80%)	$t_{MRXR}$	1.0	—	4.0	ns
RX_CLK clock fall time (80%–20%)	$t_{MRXF}$	1.0	—	4.0	ns

**Note:** The frequency of RX\_CLK should not exceed the frequency of TX\_CLK by more than 300 ppm.

This figure provides the AC test load for eTSEC.

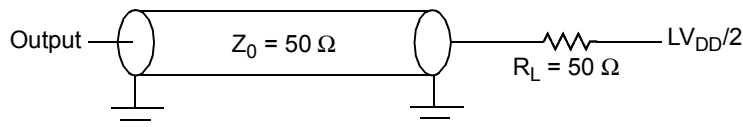

Figure 16. eTSEC AC Test Load

This figure shows the MII receive AC timing diagram.

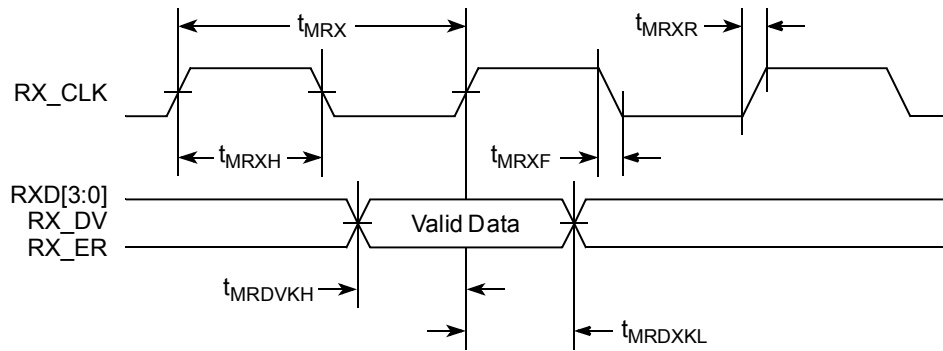

Figure 17. MII Receive AC Timing Diagram

### 2.11.2 RMII AC Timing Specifications

In RMII mode, the reference clock should be fed to TSEC<sub>n</sub>\_TX\_CLK. This section describes the RMII transmit and receive AC timing specifications.

This table lists the RMII transmit AC timing specifications.

Table 36. RMII Transmit AC Timing Specifications

For recommended operating conditions, see Table 3.

Parameter	Symbol	Min	Typ	Max	Unit
TSEC <sub>n</sub> _TX_CLK clock period	$t_{RMT}$	—	20.0	—	ns
TSEC <sub>n</sub> _TX_CLK duty cycle	$t_{RMTH}$	35	—	65	%
TSEC <sub>n</sub> _TX_CLK peak-to-peak jitter	$t_{RMTJ}$	—	—	250	ps
Rise time TSEC <sub>n</sub> _TX_CLK (20%–80%)	$t_{RMTR}$	1.0	—	5.0	ns
Fall time TSEC <sub>n</sub> _TX_CLK (80%–20%)	$t_{RMTF}$	1.0	—	5.0	ns
TSEC <sub>n</sub> _TX_CLK to RMII data TXD[1:0], TX_EN delay	$t_{RMTDX}$	2.0	—	10.0	ns

This figure shows the RMII transmit AC timing diagram.

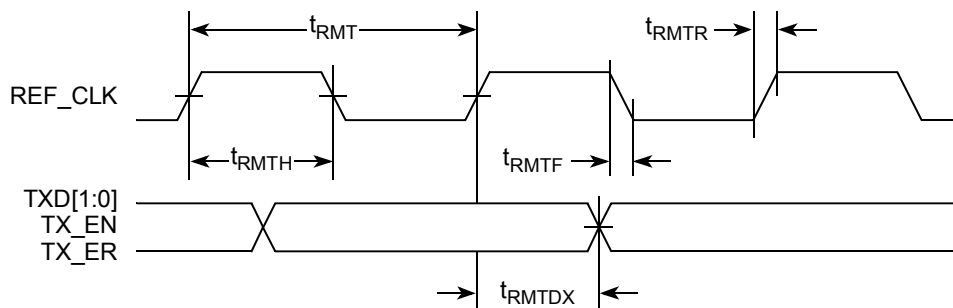

Figure 18. RMII Transmit AC Timing Diagram

## Electrical Characteristics

This table lists the RMI receive AC timing specifications.

**Table 37. RMI Receive AC Timing Specifications**

For recommended operating conditions, see [Table 3](#)

Parameter	Symbol	Min	Typ	Max	Unit
TSEcn_TX_CLK clock period	$t_{RMR}$	—	20.0	—	ns
TSEcn_TX_CLK duty cycle	$t_{RMRH}$	35	—	65	%
TSEcn_TX_CLK peak-to-peak jitter	$t_{RMRJ}$	—	—	250	ps
Rise time TSEcn_TX_CLK (20%–80%)	$t_{RMRR}$	1.0	—	5.0	ns
Fall time TSEcn_TX_CLK (80%–20%)	$t_{RMRF}$	1.0	—	5.0	ns
RXD[1:0], CRS_DV, RX_ER setup time to TSEcn_TX_CLK rising edge	$t_{RMRDV}$	4.0	—	—	ns
RXD[1:0], CRS_DV, RX_ER hold time to TSEcn_TX_CLK rising edge	$t_{RMRDX}$	2.0	—	—	ns

This figure provides the AC test load for eTSEC.

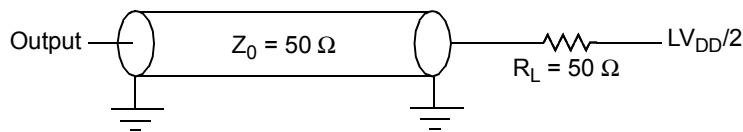

**Figure 19. eTSEC AC Test Load**

This figure shows the RMI receive AC timing diagram.

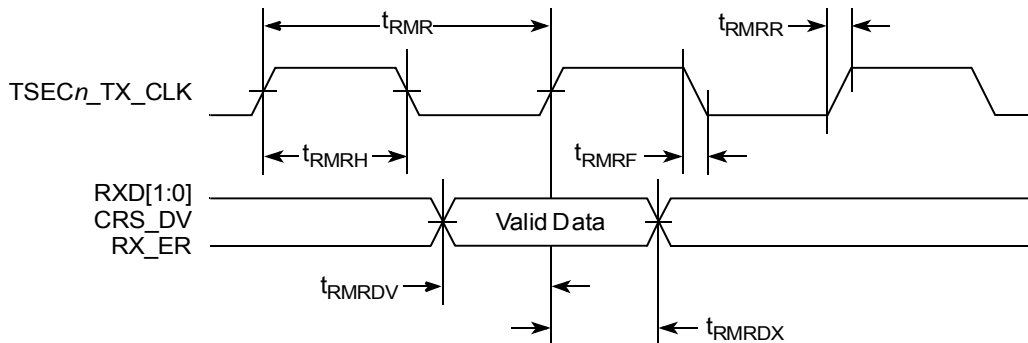

**Figure 20. RMI Receive AC Timing Diagram**

## 2.11.3 RGMII Interface Electrical Specifications

This section provides AC and DC electrical characteristics of RGMII interface for eTSEC.

### 2.11.3.1 RGMII DC Electrical Characteristics

This table shows the RGMII DC electrical characteristics when operating from a 2.5 V supply.

**Table 38. RGMII DC Electrical Characteristics (2.5V)**

At recommended operating conditions with  $LV_{DD} = 2.5\text{ V}$

Parameter	Symbol	Min	Max	Unit	Notes
Input high voltage	$V_{IH}$	1.70	—	V	—
Input low voltage	$V_{IL}$	—	0.70	V	—
Input high current ( $V_{IN} = LV_{DD}$ )	$I_{IH}$	—	50	$\mu\text{A}$	—
Input low current ( $V_{IN} = \text{GND}$ )	$I_{IL}$	-50	—	$\mu\text{A}$	2
Output high voltage ( $LV_{DD} = \text{min}$ , $I_{OH} = -1.0\text{ mA}$ )	$V_{OH}$	2.00	$LV_{DD} + 0.3$	V	—
Output low voltage ( $LV_{DD} = \text{min}$ , $I_{OL} = 1.0\text{ mA}$ )	$V_{OL}$	$\text{GND} - 0.3$	0.40	V	—

**Note:**

- Note that the min  $V_{IL}$  and max  $V_{IH}$  values are based on the respective min and max  $LV_{IN}$  values found in [Table 3](#).
- The symbol  $V_{IN}$ , in this case, represents the  $LV_{IN}$  symbols referenced in [Table 3](#).

### 2.11.3.2 RGMII AC Timing Specifications

This table presents the RGMII AC timing specifications.

**Table 39. RGMII AC Timing Specifications**

For recommended operating conditions, see [Table 3](#).

Parameter	Symbol <sup>1</sup>	Min	Typ	Max	Unit	Notes
Data to clock output skew (at transmitter)	$t_{SKRGT\_TX}$	-500	0	500	ps	5
Data to clock input skew (at receiver)	$t_{SKRGT\_RX}$	1.0	—	2.6	ns	2
Clock period duration	$t_{RGT}$	7.2	8.0	8.8	ns	3
Duty cycle for 10BASE-T and 100BASE-TX	$t_{RGTH}/t_{RGT}$	40	50	60	%	3, 4

**Table 39. RGMII AC Timing Specifications (continued)**

For recommended operating conditions, see [Table 3](#).

Parameter	Symbol <sup>1</sup>	Min	Typ	Max	Unit	Notes
Duty cycle for Gigabit	$t_{RGTH}/t_{RGT}$	45	50	55	%	—
Rise time (20%–80%)	$t_{RGTR}$	—	—	0.75	ns	—
Fall time (20%–80%)	$t_{RGTF}$	—	—	0.75	ns	—

**Notes:**

1. In general, the clock reference symbol representation for this section is based on the symbols RGT to represent RGMII timing. For example, the subscript of  $t_{RGT}$  represents the RGMII receive (RX) clock. Note also that the notation for rise (R) and fall (F) times follows the clock symbol that is being represented. For symbols representing skews, the subscript is skew (SK) followed by the clock that is being skewed (RGT).
2. This implies that PC board design will require clocks to be routed such that an additional trace delay of greater than 1.5 ns will be added to the associated clock signal. Many PHY vendors already incorporate the necessary delay inside their chip. If so, additional PCB delay is probably not needed.
3. For 10 and 100 Mbps,  $t_{RGT}$  scales to 400 ns  $\pm$  40 ns and 40 ns  $\pm$  4 ns, respectively.
4. Duty cycle may be stretched/shrunk during speed changes or while transitioning to a received packet's clock domains as long as the minimum duty cycle is not violated and stretching occurs for no more than three  $t_{RGT}$  of the lowest speed transitioned between.
5. The frequency of RX\_CLK should not exceed the frequency of GTX\_CLK125 by more than 300 ppm.

This figure shows the RGMII AC timing and multiplexing diagrams.

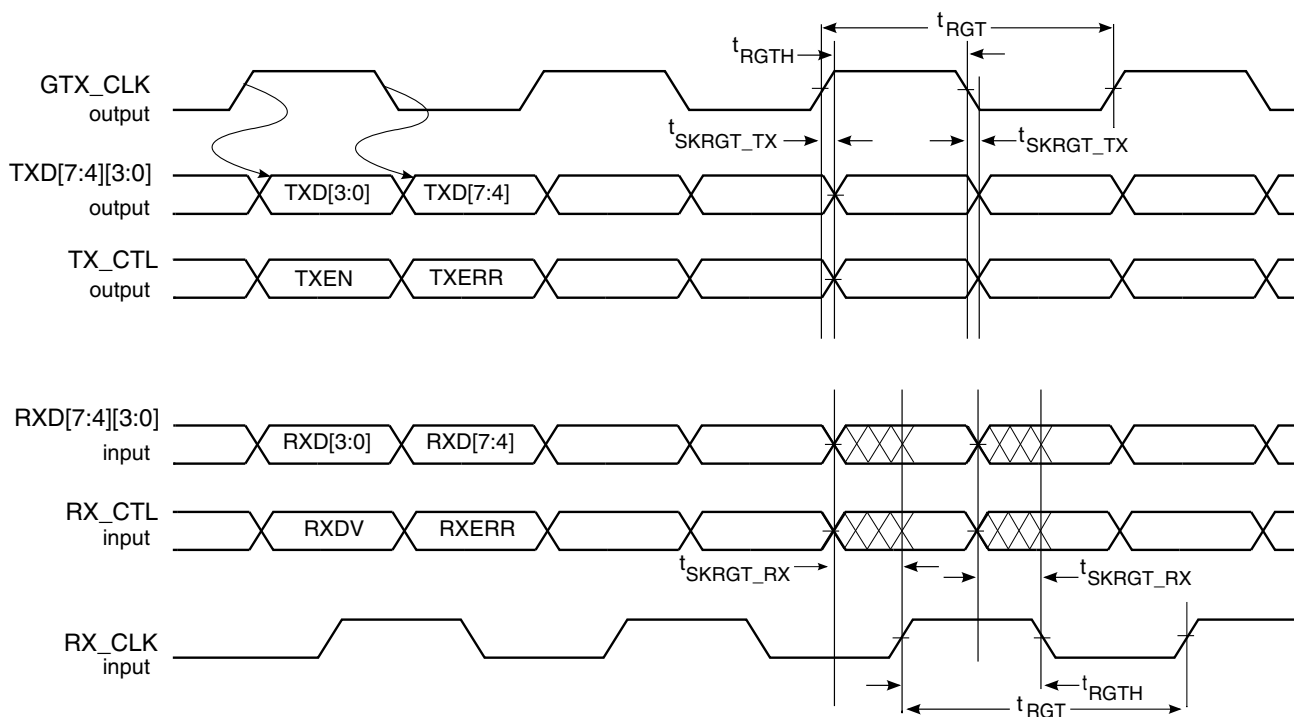

**Figure 21. RGMII AC Timing and Multiplexing Diagrams**

## 2.11.4 SGMII Interface Electrical Characteristics

Each SGMII port features a 4-wire AC-Coupled serial link from the dedicated SerDes interface of P1012 as shown in [Figure 23](#), where  $C_{TX}$  is the external (on board) AC-Coupled capacitor. Each output pin of the SerDes transmitter differential pair features 50-Ω output impedance. Each input of the SerDes receiver differential pair features 50-Ω on-die termination to SGND\_SRDS. The reference circuit of the SerDes transmitter and receiver is shown in [Figure 49](#).

### 2.11.4.1 SGMII DC Electrical Characteristics

This section discusses the electrical characteristics for the SGMII interface.

#### 2.11.4.1.1 DC Requirements for SGMII SD\_REF\_CLK and SD\_REF\_CLK

The characteristics and DC requirements of the separate SerDes reference clock are described in [Section 2.18.2.2, “DC Level Requirement for SerDes Reference Clocks.”](#)

#### 2.11.4.1.2 SGMII Transmit DC Timing Specifications

This table describe the SGMII SerDes transmitter AC-Coupled DC electrical characteristics. Transmitter DC characteristics are measured at the transmitter outputs ( $SDn\_TX[n]$  and  $\overline{SDn\_TX}[n]$ ) as shown in [Figure 23](#).

**Table 40. SGMII DC Transmitter Electrical Characteristics**

For recommended operating conditions, see [Table 3](#).

Parameter	Symbol	Min	Typ	Max	Unit	Notes
Output high voltage	$V_{OH}$	—	—	$XV_{DD\_SRDS2-Typ}/2 +  V_{OD} _{-max}/2$	mV	1
Output low voltage	$V_{OL}$	$XV_{DD\_SRDS2-Typ}/2 -  V_{OD} _{-max}/2$	—	—	mV	1
Output differential voltage <sup>2, 3, 4</sup> ( $XV_{DD-Typ}$ at 1.0V)	$ V_{OD} $	304	475	689	mV	Equalization setting: 1.0x
		279	436	632		Equalization setting: 1.09x
		254	396	574		Equalization setting: 1.2x
		229	357	518		Equalization setting: 1.33x
		202	316	459		Equalization setting: 1.5x
		178	277	402		Equalization setting: 1.71x
		152	237	344		Equalization setting: 2.0x
Output impedance (single-ended)	$R_O$	40	50	60	Ω	—

Note:

- This will not align to DC-coupled SGMII.
- $|V_{OD}| = |V_{SD2\_TXn} - V_{\overline{SD2\_TXn}}|$ .  $|V_{OD}|$  is also referred as output differential peak voltage.  $V_{TX-DIFFp-p} = 2*|V_{OD}|$ .
- The  $|V_{OD}|$  value shown in the table assumes the following transmit equalization setting in the XMITEQAB (for SerDes lanes A & B) or XMITEQEF (for SerDes lanes E & E) bit field of the SerDes 2 control register:
  - The MSbit (bit 0) of the above bit field is set to zero (selecting the full  $V_{DD-DIFF-p-p}$  amplitude - power up default);
  - The LSbits (bit [1:3]) of the above bit field is set based on the equalization setting shown in table.
- The  $|V_{OD}|$  value shown in the Typ column is based on the condition of  $XV_{DD\_SRDS2-Typ}=1.0$  V, no common mode offset variation, SerDes transmitter is terminated with 100-Ω differential load between  $SD\_TX[n]$  and  $\overline{SD\_TX}[n]$ .

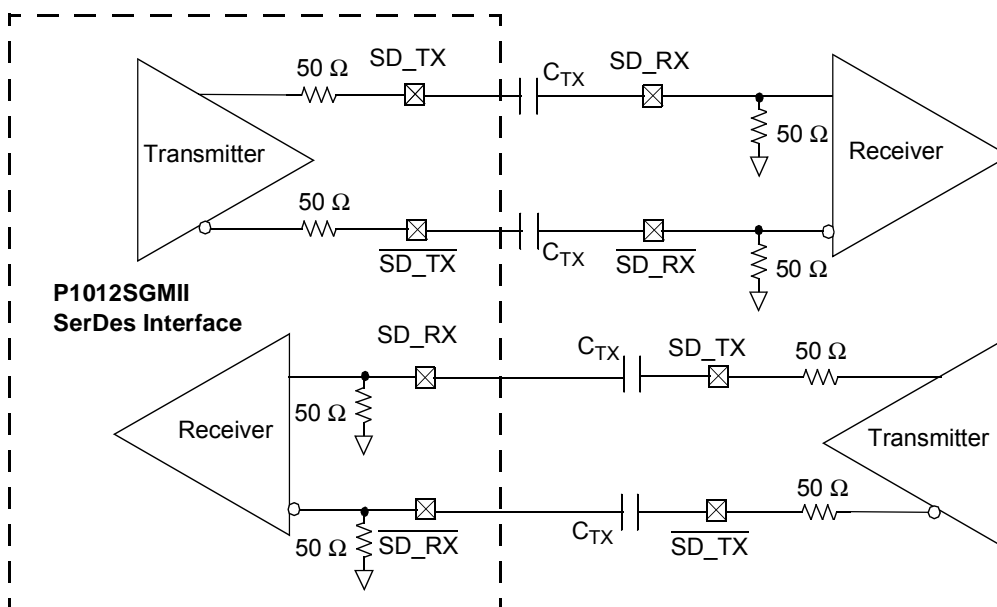

Figure 22. 4-Wire AC-Coupled SGMII Serial Link Connection Example

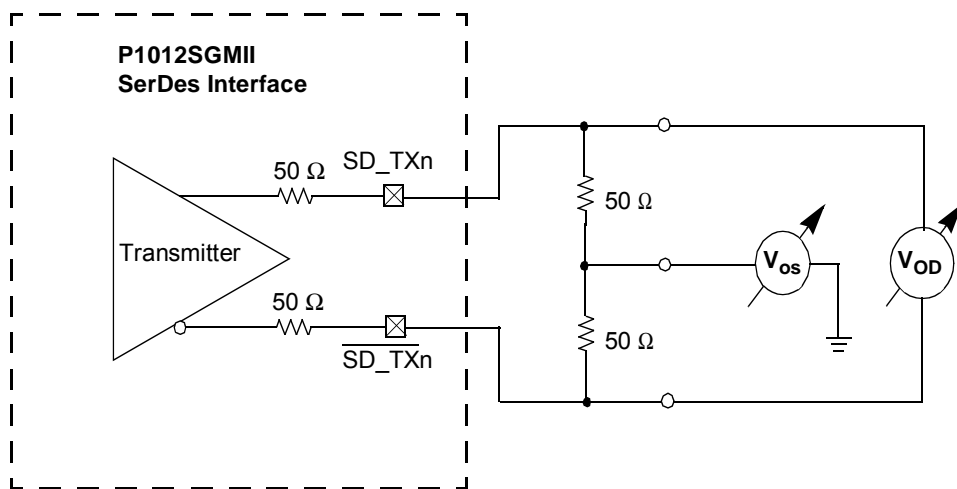

Figure 23. SGMII Transmitter DC Measurement Circuit



### 2.11.4.1.3 SGMII DC Receiver Timing Specification

This table lists the SGMII DC receiver electrical characteristics. Source synchronous clocking is not supported. Clock is recovered from the data.

**Table 41. SGMII DC Receiver Electrical Characteristics<sup>5</sup>**

For recommended operating conditions, see [Table 3](#).

Parameter	Symbol	Min	Typ	Max	Unit	Notes	
DC Input voltage range	—	N/A			—	1	
Input differential voltage	LSTS = 001	$V_{RX\_DIFFp-p}$	100	—	1200	mV	2, 4
	LSTS = 100		175	—			
Loss of signal threshold	LSTS = 001	VLOS	30	—	100	mV	3, 4
	LSTS = 100		65	—	175		
Receiver differential input impedance	$Z_{RX\_DIFF}$	80	—	120	$\Omega$	—	

**Note:**

1. Input must be externally AC-coupled.
2.  $V_{RX\_DIFFp-p}$  is also referred to as peak-to-peak input differential voltage.
3. The concept of this parameter is equivalent to the Electrical Idle Detect Threshold parameter in PCI Express. Refer to the PCI Express Differential Receiver (RX) Input Specifications section for further explanation.
4. The LSTS shown in the table refers to the EIC2[0:2] or EIC3[0:2] bit field of the GUTS\_SRDSR4 register, depending on the SerDes lane usage

### 2.11.4.2 SGMII AC Timing Specifications

This section describes the AC timing specifications for the SGMII interface.

#### 2.11.4.2.1 AC Requirements for SGMII $\overline{SD\_REF\_CLK}$ and $\overline{SD\_REF\_CLK}$

Note that the SGMII clock requirements for  $\overline{SD\_REF\_CLK}$  and  $\overline{SD\_REF\_CLK}$  are intended to be used within the clocking guidelines specified by [Section 2.18.2.3, “AC Requirements for SerDes Reference Clocks.”](#)

#### 2.11.4.2.2 SGMII Transmit AC Timing Specifications

This table provides the SGMII transmit AC timing specifications. A source synchronous clock is not supported. The AC timing specifications do not include RefClk jitter.

**Table 42. SGMII Transmit AC Timing Specifications**

At recommended operating conditions with  $XV_{DD\_SRDS} = 1.0\text{ V} \pm 50\text{ mV}$

Parameter	Symbol	Min	Typ	Max	Unit	Notes
Deterministic Jitter	JD	—	—	0.17	UI p-p	—
Total Jitter	JT	—	—	0.35	UI p-p	—
Unit Interval	UI	799.92	800	800.08	ps	—

## Electrical Characteristics

**Table 42. SGMII Transmit AC Timing Specifications (continued)**

At recommended operating conditions with  $XV_{DD\_SRDS} = 1.0\text{ V} \pm 50\text{ mV}$

Parameter	Symbol	Min	Typ	Max	Unit	Notes
AC coupling capacitor	$C_{TX}$	10	—	200	nF	3

**Notes:**

- Each UI is  $800\text{ ps} \pm 100\text{ ppm}$ .
- See [Figure 25](#) for single frequency sinusoidal jitter limits.
- The external AC coupling capacitor is required. It is recommended that it be placed near the device transmitter outputs.

### 2.11.4.2.3 SGMII AC Measurement details

Transmitter and receiver AC characteristics are measured at the transmitter outputs ( $SD\_TX[n]$  and  $\overline{SD\_TX}[n]$ ) or at the receiver inputs ( $SD\_RX[n]$  and  $\overline{SD\_RX}[n]$ ) as depicted in this figure, respectively.

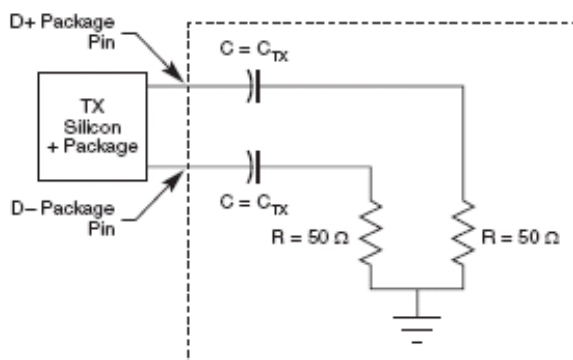

**Figure 24. SGMII AC Test/Measurement Load**

### 2.11.4.2.4 SGMII Receiver AC Timing Specifications

This table provides the SGMII receive AC timing specifications. The AC timing specifications do not include RefClk jitter. Source synchronous clocking is not supported. Clock is recovered from the data.

**Table 43. SGMII Receive AC Timing Specifications**

At recommended operating conditions with  $XV_{DD\_SRDS2} = 1.0\text{ V} \pm 50\text{ mV}$

Parameter	Symbol	Min	Typ	Max	Unit	Notes
Deterministic Jitter Tolerance	JD	0.37	—	—	UI p-p	1, 2
Combined Deterministic and Random Jitter Tolerance	JDR	0.55	—	—	UI p-p	1, 2
Total Jitter Tolerance	JT	0.65	—	—	UI p-p	1, 2
Bit Error Ratio	BER	—	—	$10^{-12}$		—
Unit Interval	UI	799.92	800	800.08	ps	3

**Notes:**

- Measured at receiver.
- Refer to RapidIO™ 1×/4× LP Serial Physical Layer Specification for interpretation of jitter specifications.
- Each UI is  $800\text{ ps} \pm 100\text{ ppm}$ .

The sinusoidal jitter in the total jitter tolerance may have any amplitude and frequency in the unshaded region of this figure.

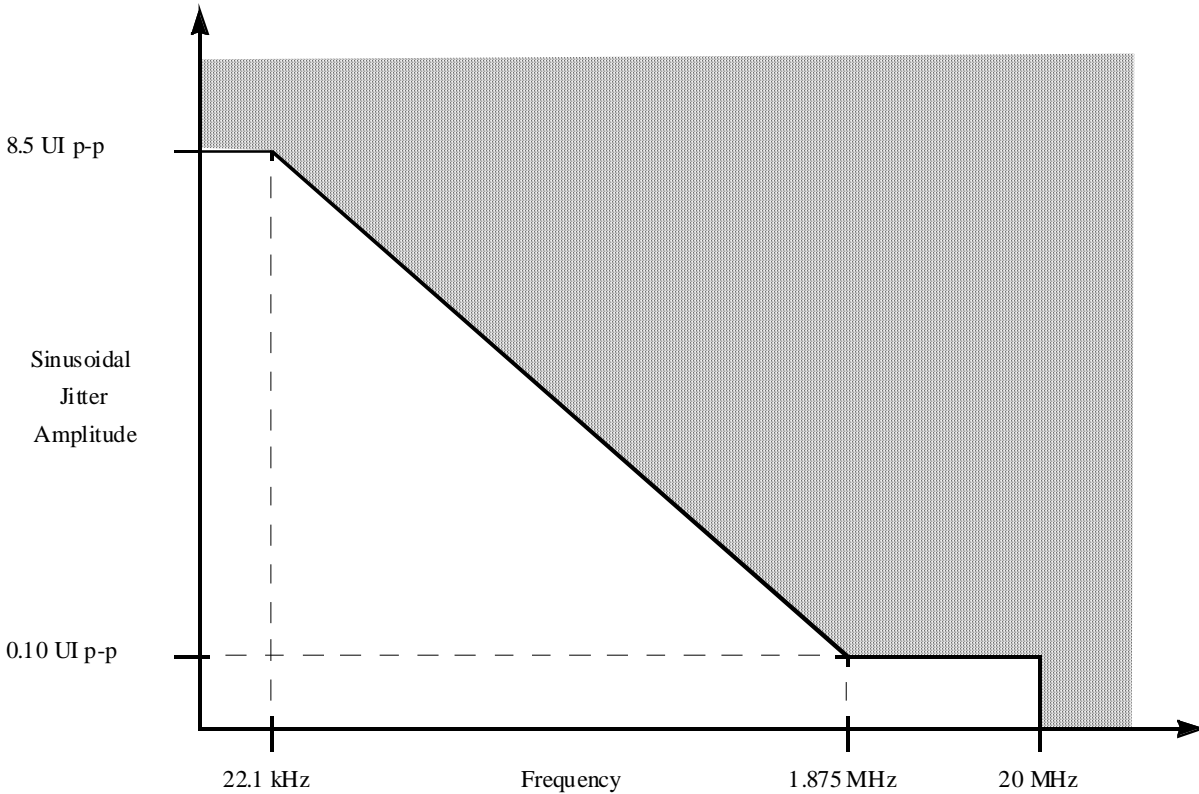

Figure 25. Single Frequency Sinusoidal Jitter Limits

## 2.11.5 MII Management

### 2.11.5.1 MII Management DC Electrical Characteristics

The MDC and MDIO are defined to operate at a supply voltage of 3.3 V and 2.5 V. The DC electrical characteristics for MDIO and MDC are provided in the following tables.

Table 44. MII Management DC Electrical Characteristics

At recommended operating conditions with  $LV_{DD} = 3.3$  V

Parameter	Symbol	Min	Max	Unit	Notes
Input high voltage	$V_{IH}$	2.0	—	V	—
Input low voltage	$V_{IL}$	—	0.90	V	—
Input high current ( $LV_{DD} = \text{Max}$ , $V_{IN} = 2.1$ V)	$I_{IH}$	—	50	$\mu\text{A}$	1
Input low current ( $LV_{DD} = \text{Max}$ , $V_{IN} = 0.5$ V)	$I_{IL}$	-50	—	$\mu\text{A}$	1
Output high voltage ( $LV_{DD} = \text{Min}$ , $I_{OH} = -1.0$ mA)	$V_{OH}$	2.4	$LV_{DD} + 0.3$	V	—

## Electrical Characteristics

**Table 44. MII Management DC Electrical Characteristics (continued)**

At recommended operating conditions with  $LV_{DD} = 3.3\text{ V}$

Parameter	Symbol	Min	Max	Unit	Notes
Output low voltage ( $LV_{DD} = \text{Min}$ , $I_{OL} = 1.0\text{ mA}$ )	$V_{OL}$	GND 0	.4	V	—

**Note:**

- Note that the symbol  $V_{IN}$ , in this case, represents the  $LV_{IN}$  symbol referenced in [Table 2](#) and [Table 3](#).

**Table 45. MII Management DC Electrical Characteristics**

At recommended operating conditions with  $LV_{DD} = 2.5\text{ V}$

Parameter	Symbol	Min	Max	Unit	Notes
Input high voltage	$V_{IH}$	1.70	$LV_{DD} + 0.3$	V	—
Input low voltage	$V_{IL}$	-0.3	0.70	V	—
Input high current ( $V_{IN} = LV_{DD}$ )	$I_{IH}$	—	50	$\mu\text{A}$	1, 2
Input low current ( $V_{IN} = \text{GND}$ )	$I_{IL}$	-50	—	$\mu\text{A}$	—
Output high voltage ( $LV_{DD} = \text{Min}$ , $I_{OH} = -1.0\text{ mA}$ )	$V_{OH}$	2.00	$LV_{DD} + 0.3$	V	—
Output low voltage ( $LV_{DD} = \text{Min}$ , $I_{OL} = 1.0\text{ mA}$ )	$V_{OL}$	$\text{GND} - 0.3$	0.40	V	—

**Notes:**

- EC1\_MDC and EC1\_MDIO operate on  $LV_{DD}$ .
- Note that the symbol  $V_{IN}$ , in this case, represents the  $LV_{IN}$  and  $TV_{IN}$  symbols referenced in [Table 3](#).

### 2.11.5.1.1 MII Management AC Electrical Specifications

This table provides the MII management AC timing specifications.

**Table 46. MII Management AC Timing Specifications**

Parameter	Symbol	Min	Typ	Max	Unit	Notes
MDC frequency	$f_{MDC}$	—	2.5	—	MHz	2
MDC period	$t_{MDC}$	—	400	—	ns	—
MDC clock pulse width high	$t_{MDCH}$	32	—	—	ns	—
MDC to MDIO delay	$t_{MDKHDX}$	$(16 \cdot t_{plb\_clk}) - 3$	—	$(16 \cdot t_{plb\_clk}) + 3$	ns	3, 4
MDIO to MDC setup time	$t_{MDDVKH}$	5	—	—	ns	—

**Table 46. MII Management AC Timing Specifications (continued)**

Parameter	Symbol	Min	Typ	Max	Unit	Notes
MDIO to MDC hold time	$t_{MDDXKH}$	0	—	—	ns	—

**Notes:**

- The symbols used for timing specifications follow the pattern of  $t_{(\text{first two letters of functional block})(\text{signal})(\text{state})(\text{reference})(\text{state})}$  for inputs and  $t_{(\text{first two letters of functional block})(\text{reference})(\text{state})(\text{signal})(\text{state})}$  for outputs. For example,  $t_{MDKHDX}$  symbolizes management data timing (MD) for the time  $t_{MDC}$  from clock reference (K) high (H) until data outputs (D) are invalid (X) or data hold time. Also,  $t_{MDDVKH}$  symbolizes management data timing (MD) with respect to the time data input signals (D) reach the valid state (V) relative to the  $t_{MDC}$  clock reference (K) going to the high (H) state or setup time. For rise and fall times, the latter convention is used with the appropriate letter: R (rise) or F (fall).
- This parameter is dependent on the platform clock frequency (MIIMCFG [MgmtClk] field determines the clock frequency of the MgmtClk Clock EC\_MDC).
- This parameter is dependent on the platform clock frequency. The delay is equal to 16 platform clock periods  $\pm 3$  ns. For example, with a platform clock of 333 MHz, the min/max delay is 48 ns  $\pm 3$  ns. Similarly, if the platform clock is 400 MHz, the min/max delay is 40 ns  $\pm 3$  ns.
- $t_{plb\_clk}$  is the platform (CCB) clock.

This figure shows the MII management interface timing diagram.

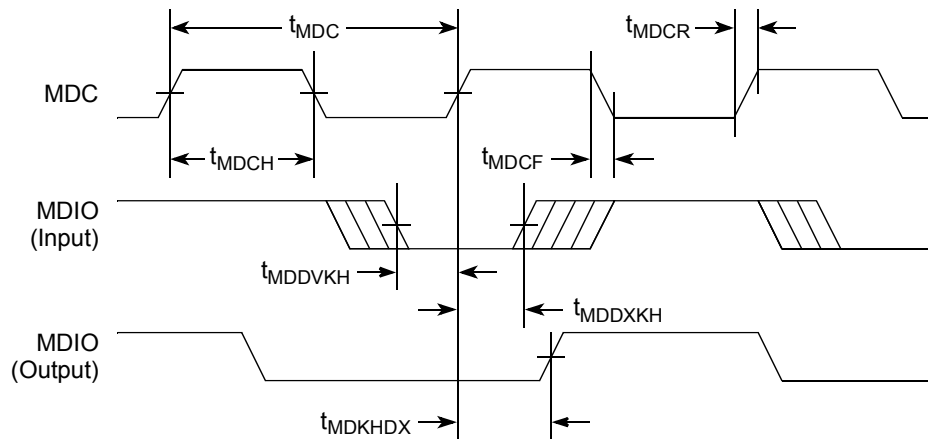
**Figure 26. MII Management Interface Timing Diagram**

## 2.11.6 eTSEC IEEE Std 1588™ Timing Specifications

### 2.11.6.1 eTSEC IEEE Std 1588 DC Electrical Characteristics

This table shows eTSEC IEEE Std 1588 DC electrical characteristics when operating at  $V_{DD} = 3.3$  V supply.

**Table 47. eTSEC IEEE 1588 DC Electrical Characteristics ( $V_{DD} = 3.3$  V)**

For recommended operating conditions with  $V_{DD} = 3.3$  V

Parameter	Symbol	Min	Max	Unit	Notes
Input high voltage	$V_{IH}$	2.0	—	V	2
Input low voltage	$V_{IL}$	—	0.9	V	2
Input high current ( $V_{DD} = \text{Max}$ , $V_{IN} = 2.1$ V)	$I_{IH}$	—	50	$\mu\text{A}$	1

## Electrical Characteristics

**Table 47. eTSEC IEEE 1588 DC Electrical Characteristics (LV<sub>DD</sub> = 3.3 V) (continued)**

For recommended operating conditions with LV<sub>DD</sub> = 3.3 V

Parameter	Symbol	Min	Max	Unit	Notes
Input low current (LV <sub>DD</sub> = Max, V <sub>IN</sub> = 0.5 V)	I <sub>IL</sub>	-50	—	μA	1
Output high voltage (LV <sub>DD</sub> = Min, I <sub>OH</sub> = -1.0 mA)	V <sub>OH</sub>	2.4	—	V	—
Output low voltage (LV <sub>DD</sub> = Min, I <sub>OL</sub> = 1.0 mA)	V <sub>OL</sub>	—	0.4	V	—

**Note:**

- Note that the symbol V<sub>IN</sub>, in this case, represents the LV<sub>IN</sub> symbol referenced in [Table 2](#) and [Table 3](#).
- The min V<sub>IL</sub> and max V<sub>IH</sub> values are based on the respective LV<sub>IN</sub> values found in [Table 3](#).

This table shows the IEEE 1588 DC electrical characteristics when operating at LV<sub>DD</sub> = 2.5 V supply.

**Table 48. eTSEC IEEE 1588 DC Electrical Characteristics (LV<sub>DD</sub> = 2.5 V)**

For recommended operating conditions with LV<sub>DD</sub> = 2.5 V

Parameter	Symbol	Min	Max	Unit	Notes
Input high voltage	V <sub>IH</sub>	1.70	—	V	—
Input low voltage	V <sub>IL</sub>	—	0.70	V	—
Input current (LV <sub>IN</sub> = 0 V or LV <sub>IN</sub> = LV <sub>DD</sub> )	I <sub>IH</sub>	—	±50	μA	2
Output high voltage (LV <sub>DD</sub> = min, I <sub>OH</sub> = -1.0 mA)	V <sub>OH</sub>	2.00	—	V	—
Output low voltage (LV <sub>DD</sub> = min, I <sub>OL</sub> = 1.0 mA)	V <sub>OL</sub>	—	0.40	V	—

**Note:**

- The min V<sub>IL</sub> and max V<sub>IH</sub> values are based on the respective min and max LV<sub>IN</sub> values found in [Table 3](#).
- The symbol V<sub>IN</sub>, in this case, represents the LV<sub>IN</sub> symbols referenced in [Table 2](#) and [Table 3](#).

### 2.11.6.2 eTSEC IEEE 1588 AC Specifications

This table provides the IEEE 1588 AC timing specifications.

**Table 49. eTSEC IEEE 1588 AC Timing Specifications**

For recommended operating conditions, see [Table 3](#).

Parameter	Symbol	Min	Typ	Max	Unit	Note
TSEC_1588_CLK clock period	t <sub>T1588CLK</sub>	5	—	T <sub>RX_CLK</sub> × 7	ns	1, 3
TSEC_1588_CLK duty cycle	t <sub>T1588CLKH</sub> /t <sub>T1588CLK</sub>	40	50	60	%	—
TSEC_1588_CLK peak-to-peak jitter	t <sub>T1588CLKINJ</sub>	—	—	250	ps	—
Rise time eTSEC_1588_CLK (20%–80%)	t <sub>T1588CLKINR</sub>	1.0	—	2.0	ns	—
Fall time eTSEC_1588_CLK (80%–20%)	t <sub>T1588CLKINF</sub>	1.0	—	2.0	ns	—
TSEC_1588_CLK_OUT clock period	t <sub>T1588CLKOUT</sub>	2 × t <sub>T1588CLK</sub>	—	—	ns	—
TSEC_1588_CLK_OUT duty cycle	t <sub>T1588CLKOTH</sub> /t <sub>T1588CLKOUT</sub>	30	50	70	%	—
TSEC_1588_PULSE_OUT	t <sub>T1588OV</sub>	0.5	—	3.0	ns	—

**Table 49. eTSEC IEEE 1588 AC Timing Specifications (continued)**

 For recommended operating conditions, see [Table 3](#).

Parameter	Symbol	Min	Typ	Max	Unit	Note
TSEC_1588_TRIG_IN pulse width	$t_{T1588TRIGH}$	$2 \times t_{T1588CLK\_MAX}$	—	—	ns	2

**Note:**

- $T_{RX\_CLK}$  is the max clock period of eTSEC receiving clock selected by TMR\_CTRL[CKSEL]. See the *P1021 QorIQ Integrated Processor Reference Manual* for a description of TMR\_CTRL registers.
- It needs to be at least two times the clock period of the clock selected by TMR\_CTRL[CKSEL]. See the *P1021 QorIQ Integrated Processor Reference Manual* for a description of TMR\_CTRL registers.
- The maximum value of  $t_{T1588CLK}$  is not only defined by the value of  $T_{RX\_CLK}$ , but also defined by the recovered clock. For example, for 10/100/1000 Mbps modes, the maximum value of  $t_{T1588CLK}$  will be 2800, 280, and 56 ns respectively.

This figure shows the data and command output AC timing diagram.

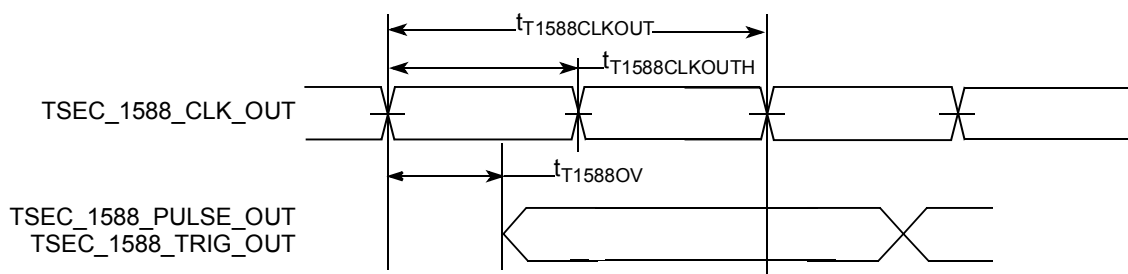

**Note:** The output delay is counted starting at the rising edge if  $t_{T1588CLKOUT}$  is non inverting. Otherwise, it is counted starting at the falling edge.

**Figure 27. eTSEC IEEE 1588 Output AC Timing**

This figure shows the data and command input AC timing diagram.

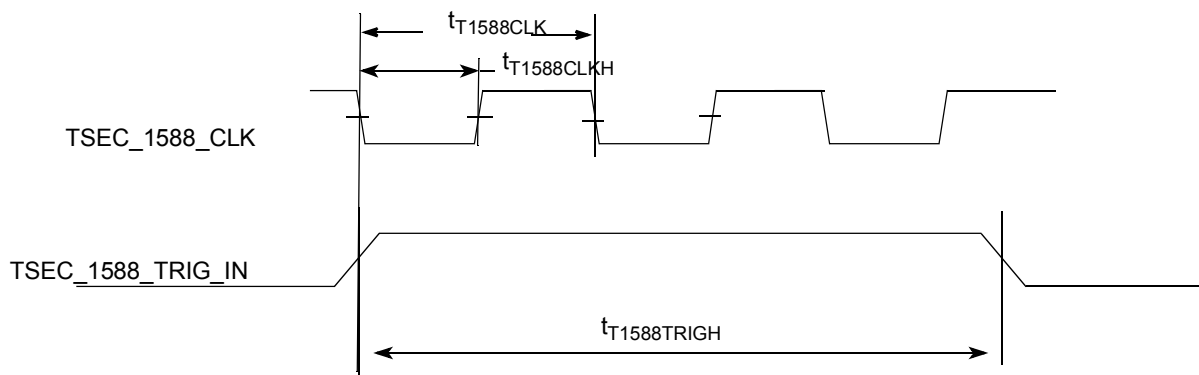
**Figure 28. eTSEC IEEE 1588 Input AC Timing**

## 2.12 USB

This section provides the AC and DC electrical specifications for the USB interface of the P1012.

### 2.12.1 USB DC Electrical Characteristics

The following tables provides the DC electrical characteristics for the USB interface.

**Table 50. USB DC Electrical Characteristics (CV<sub>DD</sub> = 3.3 V)**

For recommended operating conditions, see [Table 3](#).

Parameter	Symbol	Min	Max	Unit	Notes
Input high voltage	V <sub>IH</sub>	2	—	V	1
Input low voltage	V <sub>IL</sub>	—	0.8	V	1
Input current (CV <sub>IN</sub> = 0V or CV <sub>IN</sub> = CV <sub>DD</sub> ) I	I <sub>IN</sub>	—	±50	μA	2
Output High voltage (CV <sub>DD</sub> = min, I <sub>OH</sub> = -2 mA)	V <sub>OH</sub>	2.8	—	V	—
Output Low voltage (CV <sub>DD</sub> = min, I <sub>OL</sub> = 2 mA)	V <sub>OL</sub>	—	0.3	V	—

**Note:**

1. Note that the min V<sub>IL</sub> and max V<sub>IH</sub> values are based on the respective min and max CV<sub>IN</sub> values found in [Table 3](#).
2. Note that the symbol CV<sub>IN</sub> represents the input voltage of the supply. It is referenced in [Table 3](#).

**Table 51. USB DC Electrical Characteristics (CV<sub>DD</sub> = 2.5 V)**

Parameter	Symbol	Min	Max	Unit	Notes
High-level input voltage <sup>1</sup>	V <sub>IH</sub>	1.7	—	V	1
Low-level input voltage	V <sub>IL</sub>	—	0.7	V	1
Input current (V <sub>IN</sub> = 0 V or V <sub>IN</sub> = CV <sub>DD</sub> )	I <sub>IN</sub>	—	±40	μA	2
High-level output voltage (CV <sub>DD</sub> = min, I <sub>OH</sub> = -1 mA)	V <sub>OH</sub>	2.0	—	V	3
Low-level output voltage (CV <sub>DD</sub> = min, I <sub>OL</sub> = 1 mA)	V <sub>OL</sub>	—	0.4	V	—

**Notes:**

1. The min V<sub>IL</sub> and max V<sub>IH</sub> values are based on the respective min and max CV<sub>IN</sub> values found in [Table 3](#).
2. The symbol V<sub>IN</sub>, in this case, represents the CV<sub>IN</sub> symbol referenced in [Section 2.1.2, "Recommended Operating Conditions."](#)
3. Not applicable for open drain signals.



**Table 52. USB DC Electrical Characteristics (CV<sub>DD</sub> = 1.8V)**

Parameter	Symbol	Min	Max	Unit	Notes
High-level input voltage <sup>1</sup>	V <sub>IH</sub>	1.25	—	V	1
Low-level input voltage	V <sub>IL</sub>	—	0.6	V	1
Input current (V <sub>IN</sub> = 0 V or V <sub>IN</sub> = CV <sub>DD</sub> )	I <sub>IN</sub>	—	±40	μA	2
High-level output voltage (CV <sub>DD</sub> = min, I <sub>OH</sub> = -0.5 mA)	V <sub>OH</sub>	1.35	—	V	3
Low-level output voltage (CV <sub>DD</sub> = min, I <sub>OL</sub> = 0.5 mA)	V <sub>OL</sub>	—	0.4	V	—

**Notes:**

1. The min V<sub>IL</sub> and max V<sub>IH</sub> values are based on the respective min and max CV<sub>IN</sub> values found in [Table 3](#).
2. The symbol V<sub>IN</sub>, in this case, represents the CV<sub>IN</sub> symbol referenced in [Section 2.1.2, “Recommended Operating Conditions.”](#)
3. Not applicable for open drain signals.

## 2.12.2 USB AC Electrical Specifications

This table describes the general timing parameters of the USB interface.

**Table 53. USB General Timing Parameters**

For recommended operating conditions, see [Table 3](#)

Parameter	Symbol	Min	Max	Unit	Notes
USB clock cycle time	t <sub>USCK</sub>	15	—	ns	2, 3, 4, 5
Input setup to USB clock—all inputs	t <sub>USIVKH</sub>	4	—	ns	2, 3, 4, 5
input hold to USB clock—all inputs	t <sub>USIXKH</sub>	1	—	ns	2, 3, 4, 5
USB clock to output valid— all outputs	t <sub>USKH OV</sub>	—	7	ns	2, 3, 4, 5
Output hold from USB clock—all outputs	t <sub>USKH OX</sub>	2	—	ns	2, 3, 4, 5

**Notes:**

1. The symbols for timing specifications follow the pattern of t<sub>(First two letters of functional block)(signal)(state) (reference)(state)</sub> for inputs and t<sub>(First two letters of functional block)(reference)(state)(signal)(state)</sub> for outputs. For example, t<sub>USIXKH</sub> symbolizes USB timing (US) for the input (I) to go invalid (X) with respect to the time the USB clock reference (K) goes high (H). Also, t<sub>USKH OX</sub> symbolizes USB timing (US) for the USB clock reference (K) to go high (H) with respect to the output (O) going invalid (X) or output hold time.
2. All timings are in reference to USB clock.
3. All signals are measured from CV<sub>DD</sub>/2 of the rising edge of the USB clock to 0.4 × CV<sub>DD</sub> of the signal in question for 3.3 V signaling levels.
4. Input timings are measured at the pin.
5. For active/float timing measurements, the high impedance or off state is defined to be when the total current delivered through the component pin is less than or equal to that of the leakage current specification.
6. When switching the data pins from outputs to inputs using the USB<sub>n</sub>\_DIR pin, the output timings will be violated on that cycle because the output buffers are tristated asynchronously. This should not be a problem, because the PHY should not be functionally looking at these signals on that cycle as per ULPI specifications.

## Electrical Characteristics

These figures provide the AC test load and signals for the USB, respectively.

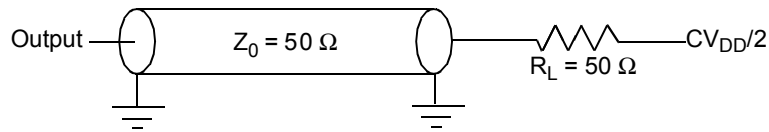

**Figure 29. USB AC Test Load**

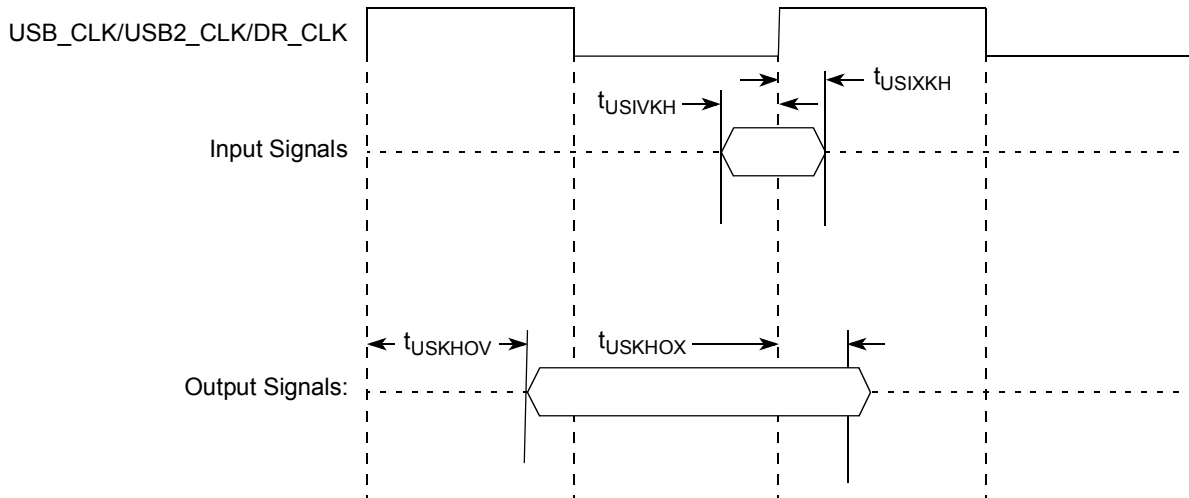

**Figure 30. USB Signals**

This table provides the USB clock input (USB\_CLK\_IN) AC timing specifications.

**Table 54. USB\_CLK\_IN AC Timing Specifications**

Parameter	Conditions	Symbol	Min	Typ	Max	Unit
Frequency range	Steady state	$f_{\text{USB\_CLK\_IN}}$	59.97	60	60.03	MHz
Clock frequency tolerance	—	$t_{\text{CLK\_TOL}}$	-0.05	0	0.05	%
Reference clock duty cycle	Measured at 1.6 V	$t_{\text{CLK\_DUTY}}$	40	50	60	%
Total input jitter/time interval error	Peak-to-peak value measured with a second order high-pass filter of 500 kHz bandwidth	$t_{\text{CLK\_PJ}}$	—	—	200	ps

## 2.13 Enhanced Local Bus

This section describes the DC and AC electrical specifications for the enhanced local bus interface.

### 2.13.1 Enhanced Local Bus DC Electrical Characteristics

This table provides the DC electrical characteristics for the enhanced local bus interface operating at  $BV_{DD} = 3.3$  V DC.

**Table 55. Enhanced Local Bus DC Electrical Characteristics (3.3 V DC)**

For recommended operating conditions, see [Table 3](#).

Parameter	Symbol	Min	Max	Unit
Input high voltage	$V_{IH}$	2	—	V
Input low voltage	$V_{IL}$	—	0.8	V
Input current ( $V_{IN} = 0$ V or $V_{IN} = BV_{DD}$ )	$I_{IN}$	—	$\pm 50$	$\mu$ A
Output high voltage ( $BV_{DD} = \text{min}$ , $I_{OH} = -2$ mA)	$V_{OH}$	2.4	—	V
Output low voltage ( $BV_{DD} = \text{min}$ , $I_{OL} = 2$ mA)	$V_{OL}$	—	0.4	V

**Note:**

1. The min  $V_{IL}$  and max  $V_{IH}$  values are based on the respective min and max  $BV_{IN}$  values found in [Table 3](#).
2. The symbol  $V_{IN}$ , in this case, represents the  $BV_{IN}$  symbol referenced in [Section 2.1.2, "Recommended Operating Conditions."](#)

### 2.13.2 Enhanced Local Bus AC Electrical Specifications

#### 2.13.2.1 Test Condition

This figure provides the AC test load for the enhanced local bus.

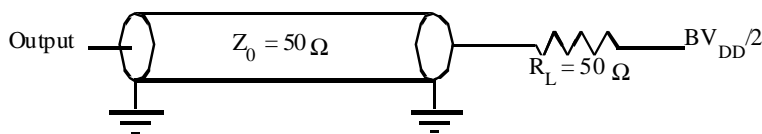

**Figure 31. Enhanced Local Bus AC Test Load**

#### 2.13.2.2 Local Bus AC Timing Specifications for PLL Bypass Mode

All output signal timings are relative to the falling edge of any LCLKs for PLL bypass mode. The external circuit must use the rising edge of the LCLKs to latch the data.

All input timings except LGTA/LUPWAIT/LFRB are relative to the rising edge of LCLKs. LGTA/LUPWAIT/LFRB are relative to the falling edge of LCLKs.

## Electrical Characteristics

This table describes the timing specifications of the local bus interface for PLL bypass mode.

**Table 56. Enhanced Local Bus Timing Specifications (BV<sub>DD</sub> = 3.3 V)—PLL Bypass Mode**

For recommended operating conditions, see [Table 3](#).

Parameter	Symbol <sup>1</sup>	Min	Max	Unit	Notes
Local bus cycle time	t <sub>LBK</sub>	12	—	ns	—
Local bus duty cycle	t <sub>LBKH</sub> /t <sub>LBK</sub>	45	55	%	—
LCLK[n] skew to LCLK[m] or LSYNC_OUT	t <sub>LBKSKEW</sub>	—	150	ps	2
Input setup (except LGTA/LUPWAIT/LFRB)	t <sub>LBIVKH</sub>	6	—	ns	—
Input hold (except LGTA/LUPWAIT/LFRB)	t <sub>LBIXKH</sub>	1	—	ns	—
Input setup (for LGTA/LUPWAIT/LFRB)	t <sub>LBIVKL</sub>	6	—	ns	—
Input hold (for LGTA/LUPWAIT/LFRB)	t <sub>LBIXKL</sub>	1	—	ns	—
Output delay (Except LALE)	t <sub>LBKLOV</sub>	—	1.5	ns	—
Output hold (Except LALE)	t <sub>LBKLOX</sub>	–3.5	—	ns	5
Local bus clock to output high impedance for LAD/LDP	t <sub>LBKLOZ</sub>	—	2	ns	3
LALE output negation to LAD/LDP output transition (LATCH hold time)	t <sub>LBONOT</sub>	1/2 (LBCR[AHD]=1) 1 (LBCR[AHD]=0)	—	eLBC controller clock cycle	4

**Note:**

1. All signals are measured from BV<sub>DD</sub>/2 of rising/falling edge of LCLK to BV<sub>DD</sub>/2 of the signal in question.
2. Skew measured between different LCLK signals at BV<sub>DD</sub>/2.
3. For purposes of active/float timing measurements, the high impedance or off state is defined to be when the total current delivered through the component pin is less than or equal to the leakage current specification.
4. t<sub>LBONOT</sub> is a measurement of the minimum time between the negation of LALE and any change in LAD. t<sub>LBONOT</sub> is determined by LBCR[AHD]. The unit is the eLBC controller clock cycle, which is the internal clock that runs the local bus controller, not the external LCLK. LCLK cycle = eLBC controller clock cycle × LCRR[CLKDIV]. After power on reset, LBCR[AHD] defaults to 0 and eLBC runs at maximum hold time.
5. Output hold is negative. This means that output transition happens earlier than the falling edge of LCLK.

This figure shows the AC timing diagram for PLL bypass mode.

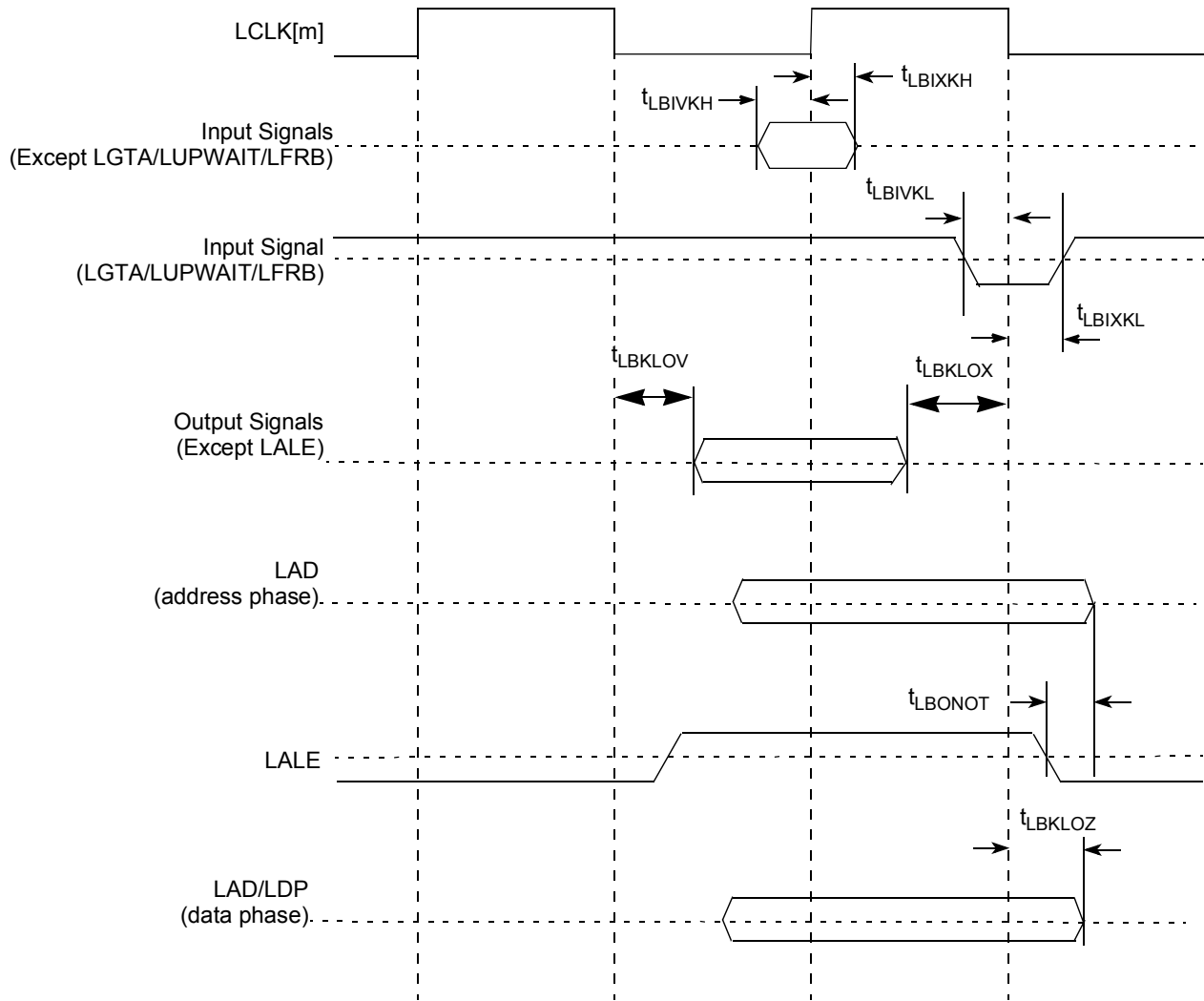

**Figure 32. Enhanced Local Bus Signals (PLL Bypass Mode)**

This figure applies to all three controllers that eLBC supports: GPCM, UPM, and FCM.

For input signals, the AC timing data is used directly for all three controllers.

For output signals, each type of controller provides its own unique method to control the signal timing. The final signal delay value for output signals is the programmed delay plus the AC timing delay. For example, for GPCM, LCS can be programmed to delay by  $t_{acs}$  (0, 1/4, 1/2, 1, 1 + 1/4, 1 + 1/2, 2, 3 cycles), so the final delay is  $t_{acs} + t_{LBKLOV}$ .

## Electrical Characteristics

This figure shows how the AC timing diagram applies to GPCM in PLL bypass mode. The same principle applies to UPM and FCM.

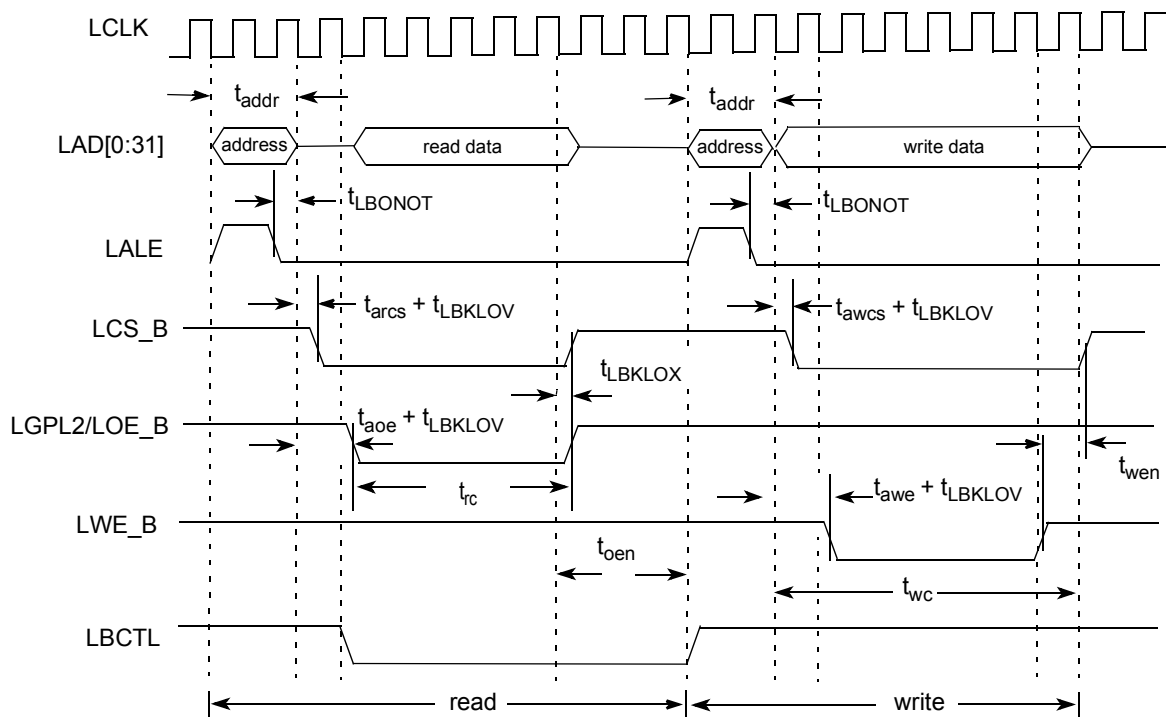

<sup>1</sup>  $t_{addr}$  is programmable and determined by LCRR[EADC] and ORx[EAD].

<sup>2</sup>  $t_{arcs}$ ,  $t_{awcs}$ ,  $t_{aoe}$ ,  $t_{rc}$ ,  $t_{oen}$ ,  $t_{awe}$ ,  $t_{wc}$ ,  $t_{wen}$  are determined by ORx. See the P1021 reference manual.

Figure 33. GPCM Output Timing Diagram (PLL Bypass Mode)

## 2.14 Enhanced Secure Digital Host Controller (eSDHC)

This section describes the DC and AC electrical specifications for the eSDHC interface.

### 2.14.1 eSDHC DC Electrical Characteristics

This table provides the DC electrical characteristics for the eSDHC interface.

Table 57. eSDHC Interface DC Electrical Characteristics

At recommended operating conditions with  $CV_{DD} = 3.3$  V

Parameter	Symbol	Condition	Min	Max	Unit	Notes
Input high voltage	$V_{IH}$	—	$0.625 \times CV_{DD}$	—	V	1
Input low voltage	$V_{IL}$	—	—	$0.25 \times CV_{DD}$	V	1
Output high voltage	$V_{OH}$	$I_{OH} = -100$ uA at $CV_{DD}$ min	$0.75 \times CV_{DD}$	—	V	—
Output low voltage	$V_{OL}$	$I_{OL} = 100$ uA at $CV_{DD}$ min	—	$0.125 \times CV_{DD}$	V	—
Output high voltage	$V_{OH}$	$I_{OH} = -100$ uA	$CV_{DD} - 2$	—	V	2
Output low voltage	$V_{OL}$	$I_{OL} = 2$ mA	—	0.3	V	2

**Table 57. eSDHC Interface DC Electrical Characteristics (continued)**

 At recommended operating conditions with  $CV_{DD} = 3.3\text{ V}$ 

Parameter	Symbol	Condition	Min	Max	Unit	Notes
Input/output leakage current	$I_{IN}/I_{OZ}$	—	-50	50	uA	—

**Note:**

- Note that the min  $V_{IL}$  and max  $V_{IH}$  values are based on the respective min and max  $CV_{IN}$  values found in [Figure 3](#).
- Open drain mode for MMC cards only.

## 2.14.2 eSDHC AC Timing Specifications

 This table provides the eSDHC AC timing specifications as defined in [Figure 35](#).

**Table 58. eSDHC AC Timing Specifications**

 At recommended operating conditions with  $CV_{DD} = 3.3\text{ V}$ 

Parameter	Symbol	Min	Max	Unit	Notes
SD_CLK clock frequency: SD/SDIO Full-speed/High-speed mode MMC Full-speed/High-speed mode	$f_{SFCK}$	0	25/50 20/52	MHz	2, 4
SD_CLK clock low time—Full-speed/High-speed mode	$t_{SFCKL}$	10/7	—	ns	4
SD_CLK clock high time—Full-speed/High-speed mode	$t_{SFCKH}$	10/7	—	ns	4
SD_CLK clock rise and fall times	$t_{SFCKR}/$ $t_{SFCKF}$	—	3	ns	4
Input setup times: SD_CMD, SD_DATx, SD_CD to SD_CLK	$t_{SFSIVKH}$	5.0	—	ns	4
Input hold times: SD_CMD, SD_DATx, SD_CD to SD_CLK	$t_{SFSIXKH}$	2.5	—	ns	3, 4
Output delay time: SD_CLK to SD_CMD, SD_DATx valid	$t_{SHSKHOV}$	-3	3	ns	4

**Note:**

- The symbols used for timing specifications herein follow the pattern of  $t_{(\text{first three letters of functional block})(\text{signal})(\text{state})(\text{reference})(\text{state})}$  for inputs and  $t_{(\text{first three letters of functional block})(\text{reference})(\text{state})(\text{signal})(\text{state})}$  for outputs. For example,  $t_{FHSKH OV}$  symbolizes eSDHC high speed mode device timing (SHS) clock reference (K) going to the high (H) state, with respect to the output (O) reaching the invalid state (X) or output hold time. Note that, in general, the clock reference symbol representation is based on five letters representing the clock of a particular functional. For rise and fall times, the latter convention is used with the appropriate letter: R (rise) or F (fall).
- In full speed mode, clock frequency value can be 0–25 MHz for a SD/SDIO card and 0–20 MHz for a MMC card. In high speed mode, clock frequency value can be 0–50 MHz for a SD/SDIO card and 0–52 MHz for a MMC card.
- To satisfy hold timing, the delay difference between clock input and cmd/data input must not exceed 2 ns.
- $C_{CARD} \leq 10\text{ pF}$ , (1 card), and  $C_L = C_{BUS} + C_{HOST} + C_{CARD} \leq 40\text{ pF}$

## Electrical Characteristics

This figure provides the eSDHC clock input timing diagram.

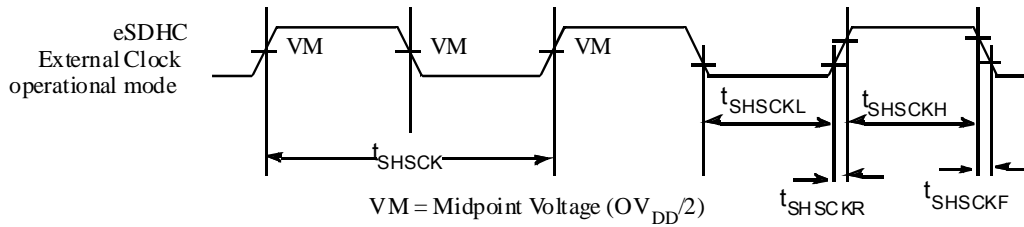

**Figure 34. eSDHC Clock Input Timing Diagram**

This figure provides the data and command input/output timing diagram.

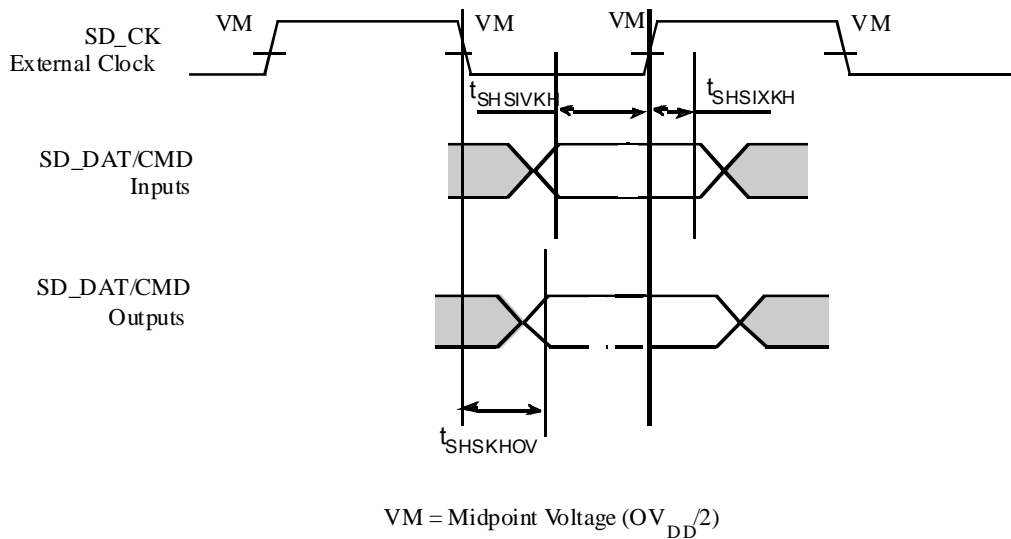

**Figure 35. eSDHC Data and Command Input/Output Timing Diagram Referenced to Clock**

## 2.15 Programmable Interrupt Controller (PIC) Specifications

This section describes the DC and AC electrical specifications for PIC.

### 2.15.1 PIC DC Electrical Characteristics

This table provides the DC electrical characteristics for the PIC interface.

**Table 59. PIC DC Electrical Characteristics**

For recommended operating conditions, see [Table 3](#).

Parameter	Symbol	Min	Max	Unit	Notes
Input high voltage	$V_{IH}$	2	—	V	1
Input low voltage	$V_{IL}$	—	0.8	V	1
Input current ( $OV_{IN} = 0V$ or $OV_{IN} = OV_{DD}$ )	$I_{IN}$	—	$\pm 50$	$\mu A$	2
Output high voltage ( $OV_{DD} = \text{min}$ , $I_{OH} = -2 \text{ mA}$ )	$V_{OH}$	2.4	—	V	—



**Table 59. PIC DC Electrical Characteristics (continued)**

 For recommended operating conditions, see [Table 3](#).

Parameter	Symbol	Min	Max	Unit	Notes
Output low voltage ( $OV_{DD} = \text{min}$ , $I_{OL} = 2 \text{ mA}$ )	$V_{OL}$	—	0.4	V	—

**Note:**

- Note that the min  $V_{IL}$  and max  $V_{IH}$  values are based on the respective min and max  $OV_{IN}$  values found in [Table 3](#).
- Note that the symbol  $OV_{IN}$  represents the input voltage of the supply. It is referenced in [Table 3](#).

## 2.15.2 PIC AC Timing Specifications

This table provides the PIC input and output AC timing specifications.

**Table 60. PIC Input AC Timing Specifications**

 For recommended operating conditions, see [Table 3](#)

Parameter	Symbol	Min	Max	Unit	Notes
PIC inputs—minimum pulse width	$t_{PIWID}$	3	—	SYSCLK	1

**Note:**

- PIC inputs and outputs are asynchronous to any visible clock. PIC outputs should be synchronized before use by any external synchronous logic. PIC inputs are required to be valid for at least  $t_{PIWID}$  ns to ensure proper operation when working in edge-triggered mode.

## 2.16 JTAG

This section describes the AC electrical specifications for the IEEE 1149.1 (JTAG) interface of the P1012.

### 2.16.1 JTAG DC Electrical Characteristics

This table provides the JTAG DC electrical characteristics.

**Table 61. JTAG DC Electrical Characteristics**

 For recommended operating conditions, see [Table 3](#).

Parameter	Symbol	Min	Max	Unit	Notes
Input high voltage	$V_{IH}$	2	—	V	1
Input low voltage	$V_{IL}$	—	0.8	V	1
Input current ( $OV_{IN} = 0V$ or $OV_{IN} = OV_{DD}$ )	$I_{IN}$	—	$\pm 50$	$\mu\text{A}$	2
Output high voltage ( $OV_{DD} = \text{min}$ , $I_{OH} = -2 \text{ mA}$ )	$V_{OH}$	2.4	—	V	—
Output low voltage ( $OV_{DD} = \text{min}$ , $I_{OL} = 2 \text{ mA}$ )	$V_{OL}$	—	0.4	V	—

**Note:**

- Note that the min  $V_{IL}$  and max  $V_{IH}$  values are based on the respective min and max  $OV_{IN}$  values found in [Table 3](#).
- Note that the symbol  $OV_{IN}$  represents the input voltage of the supply. It is referenced in [Table 3](#).

## 2.16.2 JTAG AC Timing Specifications

This table provides the JTAG AC timing specifications as defined in [Figure 36](#) through [Figure 39](#).

**Table 62. JTAG AC Timing Specifications**

For recommended operating conditions see [Table 3](#).

Parameter	Symbol	Min	Max	Unit	Notes
JTAG external clock frequency of operation	$f_{JTG}$	0	33.3	MHz	—
JTAG external clock cycle time	$t_{JTG}$	30	—	ns	—
JTAG external clock pulse width measured at 1.4 V	$t_{JTKHKL}$	15	—	ns	—
JTAG external clock rise and fall times	$t_{JTGR}$ and $t_{JTGF}$	0	2	ns	—
$\overline{TRST}$ assert time	$t_{TRST}$	25	—	ns	2
Input setup times	$t_{JTDVKH}$	4	—	ns	—
Input hold times	$t_{JTDXKH}$	10	—	ns	—
Output valid times	$t_{JTKLDV}$	4	10	ns	3
Output hold times	$t_{JTKLDX}$	30	—	ns	3

**Notes:**

1. The symbols used for timing specifications follow the pattern  $t_{(\text{first two letters of functional block})(\text{signal})(\text{state})(\text{reference})(\text{state})}$  for inputs and  $t_{(\text{first two letters of functional block})(\text{reference})(\text{state})(\text{signal})(\text{state})}$  for outputs. For example,  $t_{JTDVKH}$  symbolizes JTAG device timing (JT) with respect to the time data input signals (D) reaching the valid state (V) relative to the  $t_{JTG}$  clock reference (K) going to the high (H) state or setup time. Also,  $t_{JTDXKH}$  symbolizes JTAG timing (JT) with respect to the time data input signals (D) reaching the invalid state (X) relative to the  $t_{JTG}$  clock reference (K) going to the high (H) state. Note that in general, the clock reference symbol representation is based on three letters representing the clock of a SerDes Transmitter particular functional. For rise and fall times, the latter convention is used with the appropriate letter: R (rise) or F (fall).
2.  $\overline{TRST}$  is an asynchronous level sensitive signal. The setup time is for test purposes only.
3. All outputs are measured from the midpoint voltage of the falling/rising edge of  $t_{TCLK}$  to the midpoint of the signal in question. The output timings are measured at the pins. All output timings assume a purely resistive 50- $\Omega$  load. Time-of-flight delays must be added for trace lengths, vias, and connectors in the system.

This figure provides the AC test load for TDO and the boundary-scan outputs.

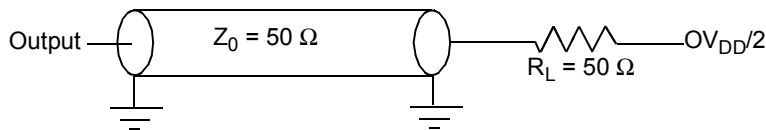

**Figure 36. AC Test Load for the JTAG Interface**

This figure provides the JTAG clock input timing diagram.

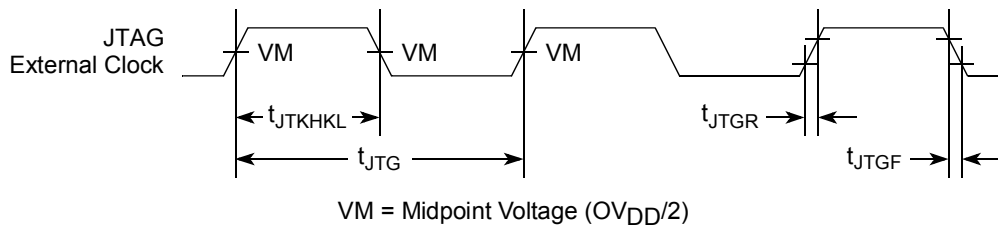

**Figure 37. JTAG Clock Input Timing Diagram**

This figure provides the  $\overline{\text{TRST}}$  timing diagram.

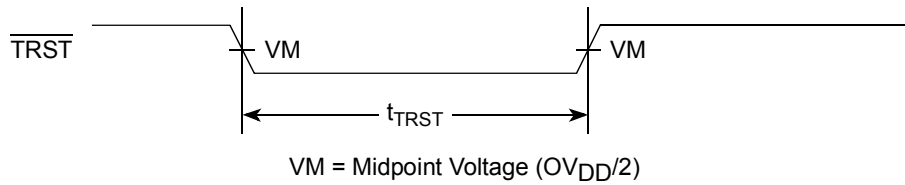

**Figure 38.  $\overline{\text{TRST}}$  Timing Diagram**

This figure provides the boundary-scan timing diagram.

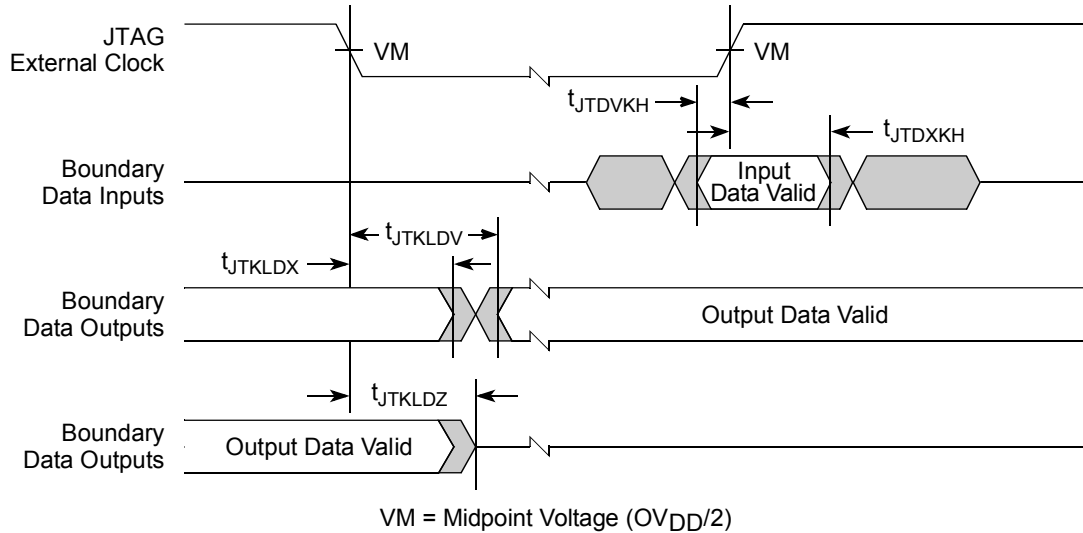

**Figure 39. Boundary-Scan Timing Diagram**

## 2.17 I<sup>2</sup>C

This section describes the DC and AC electrical characteristics for the I<sup>2</sup>C interfaces.

### 2.17.1 I<sup>2</sup>C DC Electrical Characteristics

This table provides the DC electrical characteristics for the I<sup>2</sup>C interfaces.

**Table 63. I<sup>2</sup>C DC Electrical Characteristics**

For recommended operating conditions, see [Table 3](#).

Parameter	Symbol	Min	Max	Unit	Notes
Input high voltage	$V_{IH}$	2	—	V	1
Input low voltage	$V_{IL}$	—	0.8	V	1
Output low voltage	$V_{OL}$	0	0.4	V	2
Pulse width of spikes which must be suppressed by the input filter	$t_{I2KHKL}$	0	50	ns	3
Input current each I/O pin (input voltage is between $0.1 \times OV_{DD}$ and $0.9 \times OV_{DD}(\text{max})$ )	$I_I$	-50	50	$\mu\text{A}$	4

## Electrical Characteristics

**Table 63. I<sup>2</sup>C DC Electrical Characteristics (continued)**

For recommended operating conditions, see [Table 3](#).

Parameter	Symbol	Min	Max	Unit	Notes
Capacitance for each I/O pin	$C_I$	—	10	pF	—

**Notes:**

- Note that the min  $V_{IL}$  and max  $V_{IH}$  values are based on the respective min and max  $OV_{IN}$  values found in [Table 3](#).
- Output voltage (open drain or open collector) condition = 3 mA sink current.
- Refer to the *P1021 QorIQ Integrated Processor Reference Manual* for information on the digital filter used.
- I/O pins will obstruct the SDA and SCL lines if  $OV_{DD}$  is switched off.

## 2.17.2 I<sup>2</sup>C AC Electrical Specifications

This table provides the AC timing parameters for the I<sup>2</sup>C interfaces.

**Table 64. I<sup>2</sup>C AC Electrical Specifications**

For recommended operating conditions see [Table 3](#). All values refer to  $V_{IH}$  (min) and  $V_{IL}$  (max) levels (see [Table 63](#)).

Parameter	Symbol	Min	Max	Unit	Notes
SCL clock frequency	$f_{I2C}$	0	400	kHz	<a href="#">2</a>
Low period of the SCL clock	$t_{I2CL}$	1.3	—	μs	—
High period of the SCL clock	$t_{I2CH}$	0.6	—	μs	—
Setup time for a repeated START condition	$t_{I2SVKH}$	0.6	—	μs	—
Hold time (repeated) START condition (after this period, the first clock pulse is generated)	$t_{I2SXKL}$	0.6	—	μs	—
Data setup time	$t_{I2DVKH}$	100	—	ns	—
Data hold time: CBUS compatible masters I <sup>2</sup> C bus devices	$t_{I2DXKL}$	— 0	— —	μs	<a href="#">3</a>
Data output delay time	$t_{I2OVKL}$	—	0.9	μs	<a href="#">4</a>
Set-up time for STOP condition	$t_{I2PVKH}$	0.6	—	μs	—
Bus free time between a STOP and START condition	$t_{I2KHDX}$	1.3	—	μs	—
Noise margin at the LOW level for each connected device (including hysteresis)	$V_{NL}$	$0.1 \times OV_{DD}$	—	V	—
Noise margin at the HIGH level for each connected device (including hysteresis)	$V_{NH}$	$0.2 \times OV_{DD}$	—	V	—

**Table 64. I<sup>2</sup>C AC Electrical Specifications (continued)**

For recommended operating conditions see Table 3. All values refer to  $V_{IH}$  (min) and  $V_{IL}$  (max) levels (see Table 63).

Parameter	Symbol	Min	Max	Unit	Notes
Capacitive load for each bus line	Cb	—	400	pF	

**Note:**

- The symbols used for timing specifications herein follow the pattern  $t_{(\text{first two letters of functional block})(\text{signal})(\text{state})(\text{reference})(\text{state})}$  for inputs and  $t_{(\text{first two letters of functional block})(\text{reference})(\text{state})(\text{signal})(\text{state})}$  for outputs. For example,  $t_{I2DVKH}$  symbolizes I<sup>2</sup>C timing (I2) with respect to the time data input signals (D) reaching the valid state (V) relative to the  $t_{I2C}$  clock reference (K) going to the high (H) state or setup time. Also,  $t_{I2SXKL}$  symbolizes I<sup>2</sup>C timing (I2) for the time that the data with respect to the START condition (S) went invalid (X) relative to the  $t_{I2C}$  clock reference (K) going to the low (L) state or hold time. Also,  $t_{I2PVKH}$  symbolizes I<sup>2</sup>C timing (I2) for the time that the data with respect to the STOP condition (P) reaches the valid state (V) relative to the  $t_{I2C}$  clock reference (K) going to the high (H) state or setup time.
- The requirements for I<sup>2</sup>C frequency calculation must be followed. Refer to Freescale application note AN2919, "Determining the I<sup>2</sup>C Frequency Divider Ratio for SCL."
- As a transmitter, the processor provides a delay time of at least 300 ns for the SDA signal (referred to as the  $V_{IHmin}$  of the SCL signal) to bridge the undefined region of the falling edge of SCL to avoid unintended generation of a START or STOP condition. When the processor acts as the I<sup>2</sup>C bus master while transmitting, it drives both SCL and SDA. As long as the load on SCL and SDA are balanced, the device does not generate an unintended START or STOP condition. Therefore, the 300 ns SDA output delay time is not a concern. If under some rare condition, the 300 ns SDA output delay time is required for the processor as transmitter, refer to AN2919, "Determining the I<sup>2</sup>C Frequency Divider Ratio for SCL."
- The maximum  $t_{I2OVKL}$  only must be met if the device does not stretch the LOW period ( $t_{I2CL}$ ) of the SCL signal.

This figure provides the AC test load for the I<sup>2</sup>C.

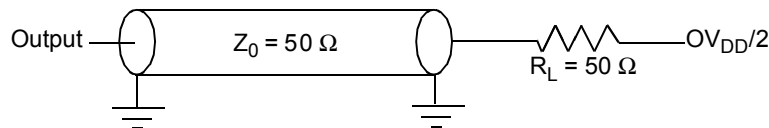
**Figure 40. I<sup>2</sup>C AC Test Load**

This figure shows the AC timing diagram for the I<sup>2</sup>C bus.

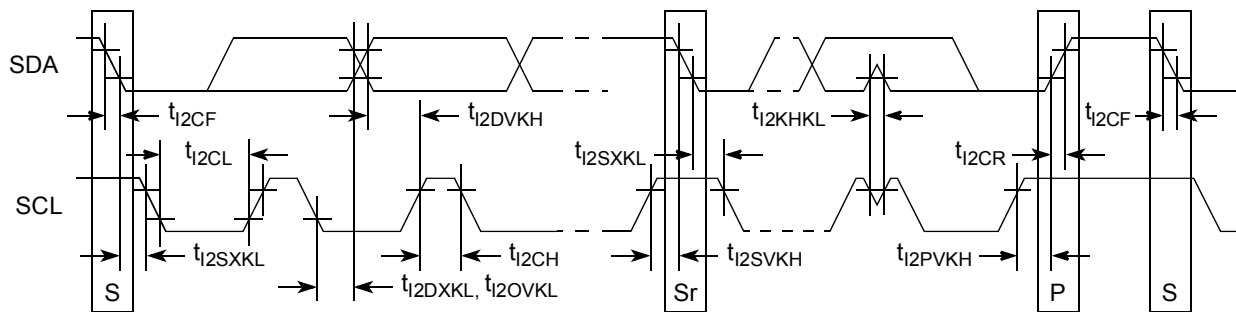
**Figure 41. I<sup>2</sup>C Bus AC Timing Diagram**

## 2.18 High-Speed Serial Interfaces (HSSI)

The P1012 features one Serializer/Deserializer (SerDes) interfaces to be used for high-speed serial interconnect applications. The SerDes interface can be used for PCI Express data transfers and for SGMII application.

This section describes the common portion of SerDes DC electrical specifications, which is the DC requirement for SerDes reference clocks. The SerDes data lane's transmitter and receiver reference circuits are also shown.

## 2.18.1 Signal Terms Definition

The SerDes utilizes differential signaling to transfer data across the serial link. This section defines terms used in the description and specification of differential signals.

Figure 42 shows how the signals are defined. For illustration purpose, only one SerDes lane is used for description. The figure shows a waveform for either a transmitter output ( $SDn\_TX$  and  $\overline{SDn\_TX}$ ) or a receiver input ( $SDn\_RX$  and  $\overline{SDn\_RX}$ ). Each signal swings between A volts and B volts where  $A > B$ .

Using this waveform, the definitions are as follows. To simplify illustration, the following definitions assume that the SerDes transmitter and receiver operate in a fully symmetrical differential signaling environment.

- **Single-Ended Swing**  
The transmitter output signals and the receiver input signals  $SDn\_TX$ ,  $\overline{SDn\_TX}$ ,  $SDn\_RX$  and  $\overline{SDn\_RX}$  each have a peak-to-peak swing of  $A - B$  volts. This is also referred as each signal wire's Single-Ended Swing.
- **Differential Output Voltage,  $V_{OD}$  (or Differential Output Swing):**  
The Differential Output Voltage (or Swing) of the transmitter,  $V_{OD}$ , is defined as the difference of the two complimentary output voltages:  $V_{SDn\_TX} - V_{\overline{SDn\_TX}}$ . The  $V_{OD}$  value can be either positive or negative.
- **Differential Input Voltage,  $V_{ID}$  (or Differential Input Swing):**  
The Differential Input Voltage (or Swing) of the receiver,  $V_{ID}$ , is defined as the difference of the two complimentary input voltages:  $V_{SDn\_RX} - V_{\overline{SDn\_RX}}$ . The  $V_{ID}$  value can be either positive or negative.
- **Differential Peak Voltage,  $V_{DIFFp}$**   
The peak value of the differential transmitter output signal or the differential receiver input signal is defined as Differential Peak Voltage,  $V_{DIFFp} = |A - B|$  Volts.
- **Differential Peak-to-Peak,  $V_{DIFFp-p}$**   
Since the differential output signal of the transmitter and the differential input signal of the receiver each range from  $A - B$  to  $-(A - B)$  Volts, the peak-to-peak value of the differential transmitter output signal or the differential receiver input signal is defined as Differential Peak-to-Peak Voltage,  $V_{DIFFp-p} = 2 \times V_{DIFFp} = 2 \times |A - B|$  Volts, which is twice of differential swing in amplitude, or twice of the differential peak. For example, the output differential peak-peak voltage can also be calculated as  $V_{TX-DIFFp-p} = 2 \times |V_{OD}|$ .
- **Differential Waveform**  
The differential waveform is constructed by subtracting the inverting signal ( $\overline{SDn\_TX}$ , for example) from the non-inverting signal ( $SDn\_TX$ , for example) within a differential pair. There is only one signal trace curve in a differential waveform. The voltage represented in the differential waveform is not referenced to ground. Refer to Figure 42 as an example for differential waveform.
- **Common Mode Voltage,  $V_{cm}$**   
The Common Mode Voltage is equal to one half of the sum of the voltages between each conductor of a balanced interchange circuit and ground. In this example, for SerDes output,  $V_{cm\_out} = (V_{SDn\_TX} + V_{\overline{SDn\_TX}})/2 = (A + B) / 2$ , which is the arithmetic mean of the two complimentary output voltages within a differential pair. In a system, the common mode voltage may often differ from one component's output to the other's input. Sometimes, it may even be different between the receiver input and driver output circuits within the same component. It is also referred to as the DC offset occasionally.

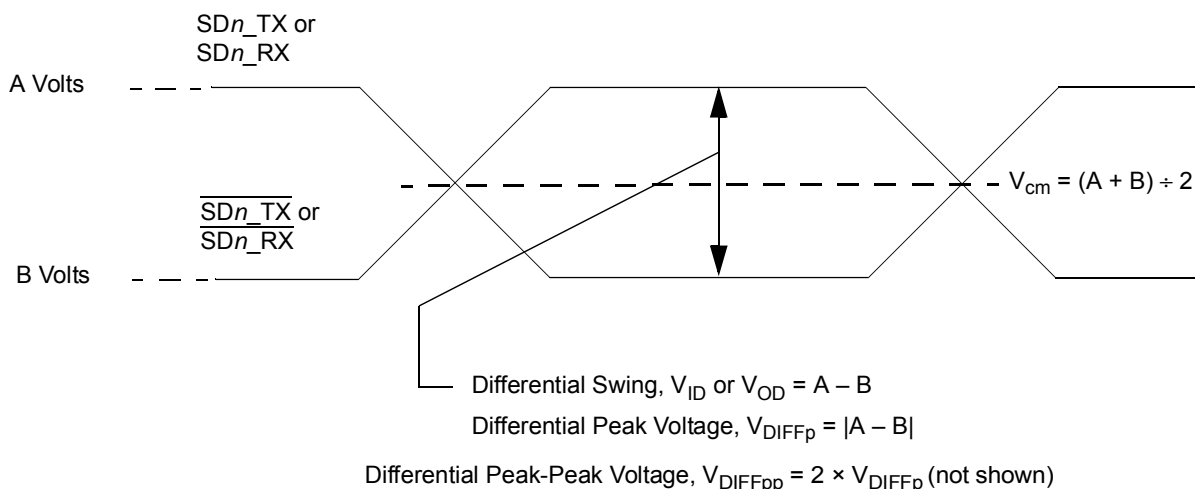

**Figure 42. Differential Voltage Definitions for Transmitter or Receiver**

To illustrate these definitions using real values, consider the case of a CML (Current Mode Logic) transmitter that has a common mode voltage of 2.25 V and each of its outputs, TD and  $\overline{TD}$ , has a swing that goes between 2.5 V and 2.0 V. Using these values, the peak-to-peak voltage swing of each signal (TD or  $\overline{TD}$ ) is 500 mV p-p, which is referred as the single-ended swing for each signal. In this example, since the differential signaling environment is fully symmetrical, the transmitter output's differential swing ( $V_{OD}$ ) has the same amplitude as each signal's single-ended swing. The differential output signal ranges between 500 mV and -500 mV, in other words,  $V_{OD}$  is 500 mV in one phase and -500 mV in the other phase. The peak differential voltage ( $V_{DIFFp}$ ) is 500 mV. The peak-to-peak differential voltage ( $V_{DIFFpp}$ ) is 1000 mV p-p.

## 2.18.2 SerDes Reference Clocks

The SerDes reference clock inputs are applied to an internal PLL whose output creates the clock used by the corresponding SerDes lanes. The SerDes reference clock inputs are  $SD\_REF\_CLK$  and  $\overline{SD\_REF\_CLK}$  for PCI Express and SGMII interface.

The following sections describe the SerDes reference clock requirements and some application information.

### 2.18.2.1 SerDes Reference Clock Receiver Characteristics

This figure shows a receiver reference diagram of the SerDes reference clocks.

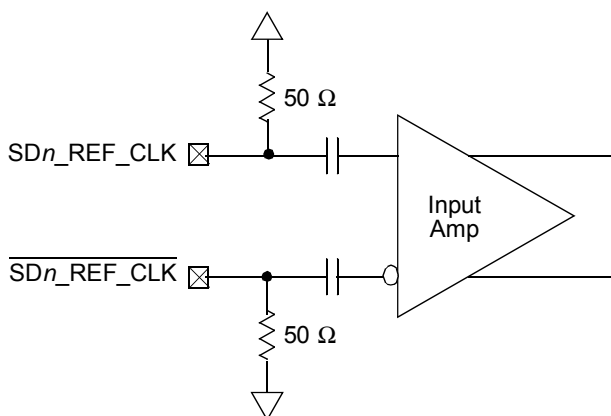

**Figure 43. Receiver of SerDes Reference Clocks**

## Electrical Characteristics

The characteristics of the clock signals are as follows:

- The supply voltage requirements for  $XV_{DD\_SRDS2}$  are specified in [Table 2](#) and [Table 3](#).
- SerDes reference clock receiver reference circuit structure
  - The  $SD\_REF\_CLK$  and  $\overline{SD\_REF\_CLK}$  are internally AC-coupled differential inputs as shown in [Figure 43](#). Each differential clock input ( $SD\_REF\_CLK$  or  $\overline{SD\_REF\_CLK}$ ) has a 50- $\Omega$  termination to  $SGND\_SRDS$  followed by on-chip AC-coupling.
  - The external reference clock driver must be able to drive this termination.
  - The SerDes reference clock input can be either differential or single-ended. Refer to the differential mode and single-ended mode descriptions in [Section 2.18.2.2](#), “DC Level Requirement for SerDes Reference Clocks,” for requirements.
- The maximum average current requirement that also determines the common mode voltage range.
  - When the SerDes reference clock differential inputs are DC coupled externally with the clock driver chip, the maximum average current allowed for each input pin is 8 mA. In this case, the exact common mode input voltage is not critical as long as it is within the range allowed by the maximum average current of 8 mA (refer to the following bullet for more detail), since the input is AC-coupled on-chip.
  - This current limitation sets the maximum common mode input voltage to be less than 0.4 V ( $0.4\text{ V} \div 50 = 8\text{ mA}$ ) while the minimum common mode input level is 0.1 V above  $SGND\_SRDS$ . For example, a clock with a 50/50 duty cycle can be produced by a clock driver with output driven by its current source from 0 mA to 16 mA (0–0.8 V), such that each phase of the differential input has a single-ended swing from 0 V to 800 mV with the common mode voltage at 400 mV.
  - If the device driving the  $SD\_REF\_CLK$  and  $\overline{SD\_REF\_CLK}$  inputs cannot drive 50  $\Omega$  to  $SGND\_SRDS$  DC, or it exceeds the maximum input current limitations, then it must be AC-coupled off-chip.

### 2.18.2.2 DC Level Requirement for SerDes Reference Clocks

The DC level requirement for the SerDes reference clock inputs is different depending on the signaling mode used to connect the clock driver chip and SerDes reference clock inputs as described below.

- **Differential Mode**
  - The input amplitude of the differential clock must be between 400 mV and 1600 mV differential peak-peak (or between 200 mV and 800 mV differential peak). In other words, each signal wire of the differential pair must have a single-ended swing less than 800 mV and greater than 200 mV. This requirement is the same for both external DC-coupled or AC-coupled connection.
  - For **external DC-coupled** connection, as described in [Section 2.18.2.1](#), “SerDes Reference Clock Receiver Characteristics,” the maximum average current requirements sets the requirement for average voltage (common mode voltage) to be between 100 mV and 400 mV. [Figure 44](#) shows the SerDes reference clock input requirement for DC-coupled connection scheme.
  - For **external AC-coupled** connection, there is no common mode voltage requirement for the clock driver. Since the external AC-coupling capacitor blocks the DC level, the clock driver and the SerDes reference clock receiver operate in different command mode voltages. The SerDes reference clock receiver in this connection scheme has its common mode voltage set to  $SGND\_SRDS$ . Each signal wire of the differential inputs is allowed to swing below and above the command mode voltage ( $SGND\_SRDS$ ). [Figure 45](#) shows the SerDes reference clock input requirement for AC-coupled connection scheme.



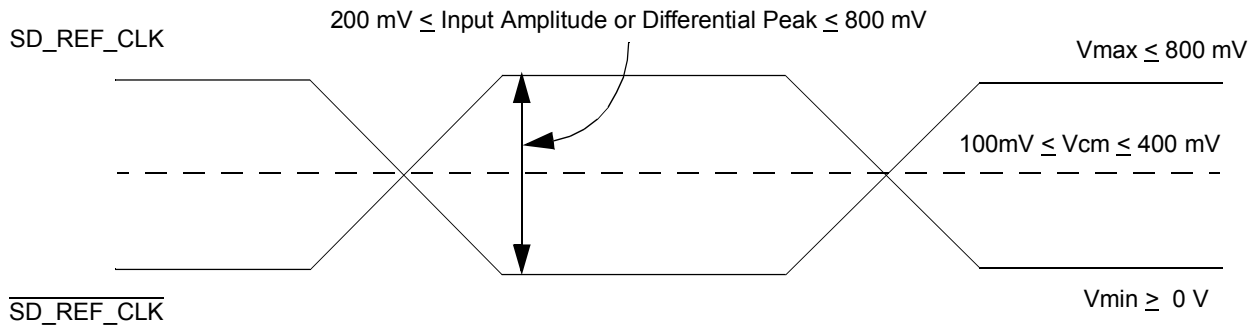

**Figure 44. Differential Reference Clock Input DC Requirements (External DC-Coupled)**

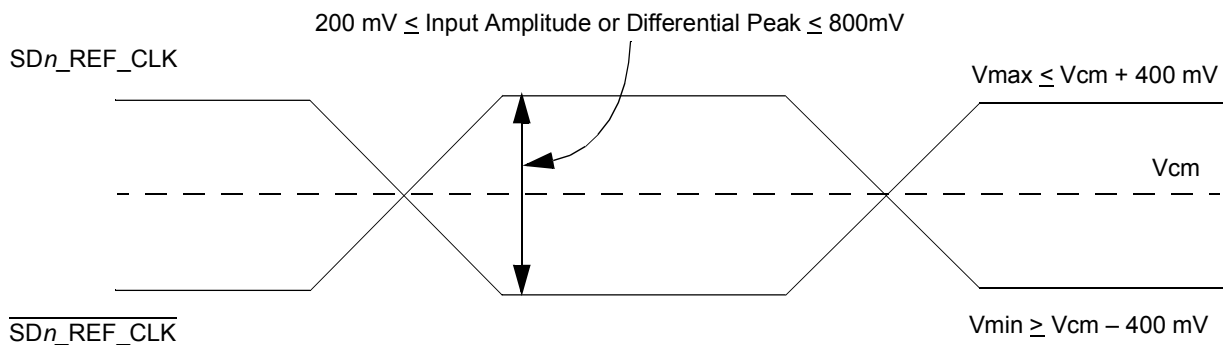

**Figure 45. Differential Reference Clock Input DC Requirements (External AC-Coupled)**

• **Single-ended Mode**

- The reference clock can also be single ended. The SD\_REF\_CLK input amplitude (single-ended swing) must be between 400 mV and 800 mV peak-peak (from  $V_{MIN}$  to  $V_{MAX}$ ) with  $\overline{SD\_REF\_CLK}$  either left unconnected or tied to ground.
- The SD\_REF\_CLK input average voltage must be between 200 and 400 mV. Figure 46 shows the SerDes reference clock input requirement for single-ended signaling mode.
- To meet the input amplitude requirement, the reference clock inputs might need to be DC or AC coupled externally. For the best noise performance, the reference of the clock could be DC or AC coupled into the unused phase ( $\overline{SD\_REF\_CLK}$ ) through the same source impedance as the clock input (SD\_REF\_CLK) in use.

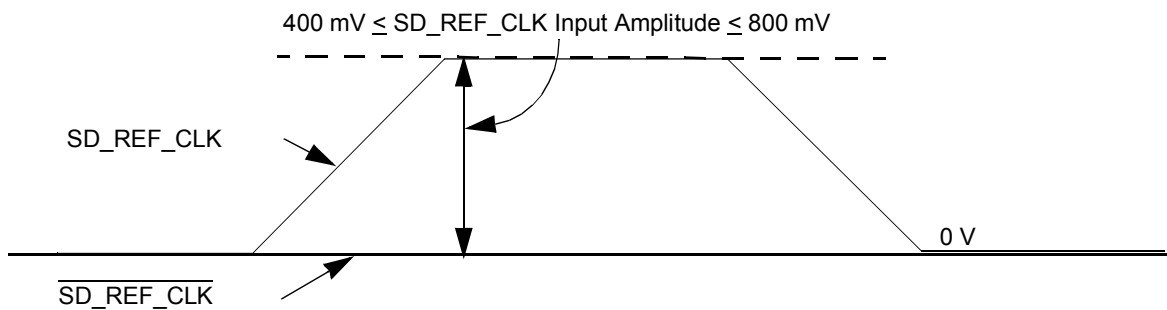

**Figure 46. Single-Ended Reference Clock Input DC Requirements**

### 2.18.2.3 AC Requirements for SerDes Reference Clocks

This table lists AC requirements for the PCI Express and SGMII SerDes reference clocks to be guaranteed by the customer’s application design.

**Table 65. SD\_REF\_CLK and  $\overline{\text{SD\_REF\_CLK}}$  Input Clock Requirements**

Parameter	Symbol	Min	Typical	Max	Unit	Notes
SD_REF_CLK/ $\overline{\text{SD\_REF\_CLK}}$ frequency range	$t_{\text{CLK\_REF}}$	—	100/125	—	MHz	1
SD_REF_CLK/ $\overline{\text{SD\_REF\_CLK}}$ clock frequency tolerance	$t_{\text{CLK\_TOL}}$	-350	—	+350	ppm	—
SD_REF_CLK/ $\overline{\text{SD\_REF\_CLK}}$ reference clock duty cycle	$t_{\text{CLK\_DUTY}}$	40	50	60	%	4
SD_REF_CLK/ $\overline{\text{SD\_REF\_CLK}}$ max deterministic peak-peak Jitter at $10^{-6}$ BER	$t_{\text{CLK\_DJ}}$	—	—	42	ps	—
SD_REF_CLK/ $\overline{\text{SD\_REF\_CLK}}$ total reference clock jitter at $10^{-6}$ BER (Peak-to-peak jitter at refClk input)	$t_{\text{CLK\_TJ}}$	—	—	86	ps	2
SD_REF_CLK/ $\overline{\text{SD\_REF\_CLK}}$ rising/falling edge rate	$t_{\text{CLKRR}}/t_{\text{CLKFR}}$	1	—	4	V/ns	3

**Notes:**

1. Only 100/125 have been tested, other in between values will not work correctly with the rest of the system.
2. Limits from PCI Express CEM Rev 2.0.
3. Measured from -200 mV to +200 mV on the differential waveform (derived from  $\text{SD}_n\text{\_REF\_CLK}$  minus  $\overline{\text{SD}_n\text{\_REF\_CLK}}$ ). The signal must be monotonic through the measurement region for rise and fall time. The 400 mV measurement window is centered on the differential zero crossing. See Figure 47.
4. Measurement taken from differential waveform.
5. Measurement taken from single-ended waveform.
6. Matching applies to rising edge for  $\text{SD}_n\text{\_REF\_CLK}$  and falling edge rate for  $\overline{\text{SD}_n\text{\_REF\_CLK}}$ . It is measured using a 200 mV window centered on the median cross point where  $\text{SD}_n\text{\_REF\_CLK}$  rising meets  $\overline{\text{SD}_n\text{\_REF\_CLK}}$  falling. The median cross point is used to calculate the voltage thresholds that the oscilloscope uses for the edge rate calculations. The rise edge rate of  $\text{SD}_n\text{\_REF\_CLK}$  should be compared to the fall edge rate of  $\overline{\text{SD}_n\text{\_REF\_CLK}}$ , the maximum allowed difference should not exceed 20% of the slowest edge rate. See Figure 48.

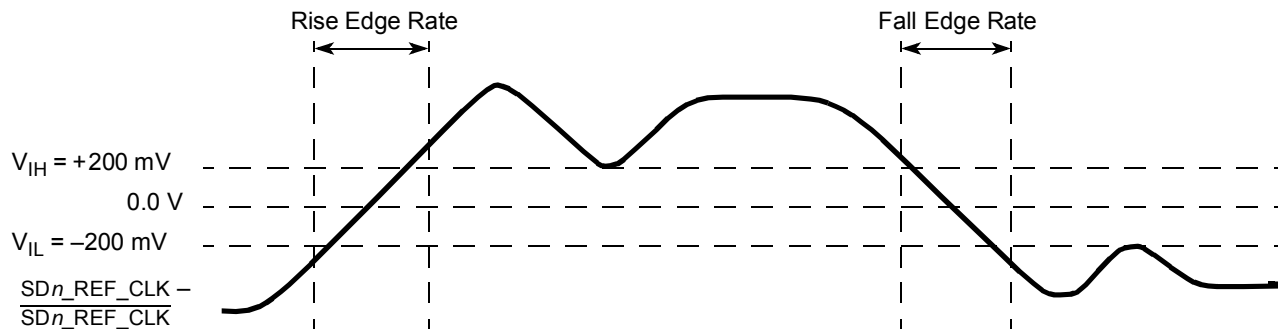

**Figure 47. Differential Measurement Points for Rise and Fall Time**

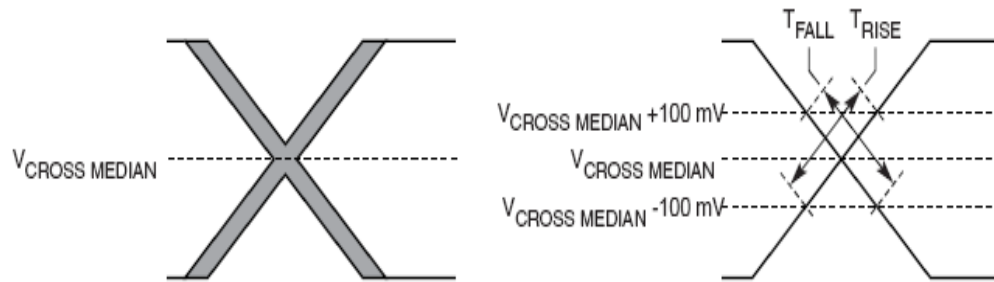

Figure 48. Single-Ended Measurement Points for Rise and Fall Time Matching

### 2.18.2.4 SerDes Transmitter and Receiver Reference Circuits

This figure shows the reference circuits for SerDes data lane's transmitter and receiver.

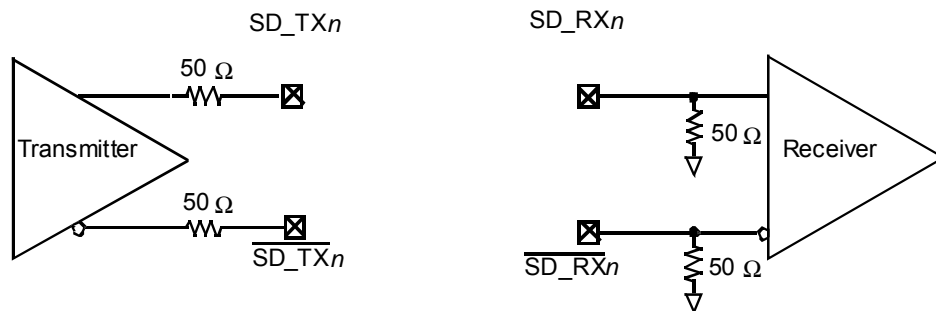

Figure 49. SerDes Transmitter and Receiver Reference Circuits

The DC and AC specification of SerDes data lanes are defined in each interface protocol section below (PCI Express, Serial Rapid IO or SGMII) in this document based on the application usage:

- [Section 2.11.4, “SGMII Interface Electrical Characteristics”](#)
- [Section 2.19, “PCI Express”](#)

Note that an external AC-coupling capacitor is required for the above three serial transmission protocols per the protocol's standard requirements.

## 2.19 PCI Express

This section describes the DC and AC electrical specifications for the PCI Express bus.

### 2.19.1 PCI Express DC Requirements for PCI Express SD\_REF\_CLK and SD\_REF\_CLK

For more information, see [Section 2.18.2.2, “DC Level Requirement for SerDes Reference Clocks.”](#)

## 2.19.2 PCI Express DC Physical Layer Specifications

This section contains the DC specifications for the physical layer of PCI Express on this device.

### 2.19.2.1 PCI Express DC Physical Layer Transmitter Specifications

This section discusses PCI Express DC physical layer transmitter specifications for 2.5 Gb/s.

This table defines the PCI Express (2.5 Gb/s) DC specifications for the differential output at all transmitters (TXs). The parameters are specified at the component pins.

**Table 66. PCI Express (2.5Gb/s) Differential Transmitter (TX) Output DC Specifications**

Symbol	Parameter	Min	Typical	Max	Units	Comments
$V_{TX-DIFFp-p}$	Differential Peak-to-Peak Output Voltage	800	1000	1200	mV	$V_{TX-DIFFp-p} = 2 \times  V_{TX-D+} - V_{TX-D-} $ See Note 1.
$V_{TX-DE-RATIO}$	De-emphasized Differential Output Voltage (Ratio)	3.0	3.5	4.0	dB	Ratio of the $V_{TX-DIFFp-p}$ of the second and following bits after a transition divided by the $V_{TX-DIFFp-p}$ of the first bit after a transition. See Note 1.
$Z_{TX-DIFF-DC}$	DC Differential TX Impedance	80	100	120	$\Omega$	TX DC Differential mode low Impedance
$Z_{TX-DC}$	Transmitter DC Impedance	40	50	60	$\Omega$	Required TX D+ as well as D- DC impedance during all states

**Note:**

1. Specified at the measurement point into a timing and voltage compliance test load as shown in [Figure 50](#) and measured over any 250 consecutive TX UIs.

### 2.19.2.2 PCI Express DC Physical Layer Receiver Specifications

This section discusses PCI Express DC physical layer receiver specifications for 2.5 Gb/s.

This table defines the PCI Express (2.5 Gb/s) DC specifications for the differential output at all receivers (RXs). The parameters are specified at the component pins.

**Table 67. PCI Express (2.5 Gb/s) Differential Receiver (RX) Input DC Specifications**

Symbol	Parameter	Min	Typical	Max	Units	Comments
$V_{RX-DIFFp-p}$	Differential Input Peak-to-Peak Voltage	175	—	1200	mV	$V_{RX-DIFFp-p} = 2 \times  V_{RX-D+} - V_{RX-D-} $ See Note 1.
$Z_{RX-DIFF-DC}$	DC Differential Input Impedance	80	100	120	$\Omega$	RX DC differential mode impedance. See Note 2
$Z_{RX-DC}$	DC Input Impedance	40	50	60	$\Omega$	Required RX D+ as well as D– DC impedance ( $50 \pm 20\%$ tolerance). See Notes 1 and 2.
$Z_{RX-HIGH-IMP-DC}$	Powered Down DC Input Impedance	50 k	—	—	$\Omega$	Required RX D+ as well as D– DC impedance when the receiver terminations do not have power. See Note 3.
$V_{RX-IDLE-DET-DIFFp-p}$	Electrical Idle Detect Threshold	65	—	175	mV	$V_{RX-IDLE-DET-DIFFp-p} = 2 \times  V_{RX-D+} - V_{RX-D-} $ Measured at the package pins of the receiver

**Notes:**

1. Specified at the measurement point and measured over any 250 consecutive UIs. The test load in [Figure 50](#) should be used as the RX device when taking measurements. If the clocks to the RX and TX are not derived from the same reference clock, the TX UI recovered from 3500 consecutive UI must be used as a reference for the eye diagram.
2. Impedance during all LTSSM states. When transitioning from a fundamental reset to detect (the initial state of the LTSSM) there is a 5 ms transition time before receiver termination values must be met on all unconfigured lanes of a port.
3. The RX DC common mode Impedance that exists when no power is present or fundamental reset is asserted. This helps ensure that the Receiver Detect circuit will not falsely assume a receiver is powered on when it is not. This term must be measured at 300 mV above the RX ground.

## 2.19.3 PCI Express AC Physical Layer Specifications

This section contains the DC specifications for the physical layer of PCI Express on this device.

### 2.19.3.1 PCI Express AC Physical Layer Transmitter Specifications

This section discusses the PCI Express AC physical layer transmitter specifications for 2.5Gb/s.

This table defines the PCI Express (2.5Gb/s) AC specifications for the differential output at all transmitters (TXs). The parameters are specified at the component pins. The AC timing specifications do not include RefClk jitter.

**Table 68. PCI Express (2.5Gb/s) Differential Transmitter (TX) Output AC Specifications**

Symbol	Parameter	Min	Typical	Max	Units	Comments
UI	Unit Interval	399.88	400.00	400.12	ps	Each UI is $400 \text{ ps} \pm 300 \text{ ppm}$ . UI does not account for spread-spectrum-clock-dictated variations. See Note 1.
$T_{TX-EYE}$	Minimum TX Eye Width	0.70	—	—	UI	The maximum transmitter jitter can be derived as $T_{TX-MAX-JITTER} = 1 - T_{TX-EYE} = 0.3 \text{ UI}$ . See Notes 2 and 3.

**Table 68. PCI Express (2.5Gb/s) Differential Transmitter (TX) Output AC Specifications (continued)**

Symbol	Parameter	Min	Typical	Max	Units	Comments
$T_{TX-EYE-MEDIAN-to-MAX-JITTER}$	Maximum time between the jitter median and maximum deviation from the median.	—	—	0.15	UI	Jitter is defined as the measurement variation of the crossing points ( $V_{TX-DIFFp-p} = 0$ V) in relation to a recovered TX UI. A recovered TX UI is calculated over 3500 consecutive unit intervals of sample data. Jitter is measured using all edges of the 250 consecutive UI in the center of the 3500 UI used for calculating the TX UI. See Notes 2 and 3.
$C_{TX}$	AC Coupling Capacitor	75	—	200	nF	All transmitters shall be AC coupled. The AC coupling is required either within the media or within the transmitting component itself. See Note 4.

**Notes:**

1. No test load is necessarily associated with this value.
2. Specified at the measurement point into a timing and voltage compliance test load as shown in [Figure 50](#) and measured over any 250 consecutive TX UIs.
3. A  $T_{TX-EYE} = 0.70$  UI provides for a total sum of deterministic and random jitter budget of  $T_{TX-JITTER-MAX} = 0.30$  UI for the Transmitter collected over any 250 consecutive TX UIs. The  $T_{TX-EYE-MEDIAN-to-MAX-JITTER}$  median is less than half of the total TX jitter budget collected over any 250 consecutive TX UIs. It should be noted that the median is not the same as the mean. The jitter median describes the point in time where the number of jitter points on either side is approximately equal as opposed to the averaged time value.
4. SerDes transmitter does not have CTX built-in. An external AC-coupling capacitor is required.

### 2.19.3.2 PCI Express AC Physical Layer Receiver Specifications

This section discusses the PCI Express AC physical layer receiver specifications for 2.5 Gb/s.

This table defines the AC specifications for the PCI Express (2.5 Gb/s) differential input at all receivers (RXs). The parameters are specified at the component pins. The AC timing specifications do not include RefClk jitter.

**Table 69. PCI Express (2.5 Gb/s) Differential Receiver (RX) Input AC Specifications**

Symbol	Parameter	Min	Typical	Max	Units	Comments
UI	Unit Interval	399.88	400.00	400.12	ps	Each UI is 400 ps $\pm$ 300 ppm. UI does not account for Spread Spectrum Clock dictated variations. See Note 1.
$T_{RX-EYE}$	Minimum Receiver Eye Width	0.4	—	—	UI	The maximum interconnect media and Transmitter jitter that can be tolerated by the Receiver can be derived as $T_{RX-MAX-JITTER} = 1 - T_{RX-EYE} = 0.6$ UI. See Notes 2 and 3.

**Table 69. PCI Express (2.5 Gb/s) Differential Receiver (RX) Input AC Specifications (continued)**

Symbol	Parameter	Min	Typical	Max	Units	Comments
$T_{RX-EYE-MEDIAN-to-MAX-JITTER}$	Maximum time between the jitter median and maximum deviation from the median.	—	—	0.3	UI	Jitter is defined as the measurement variation of the crossing points ( $V_{RX-DIFFP-p} = 0$ V) in relation to a recovered TX UI. A recovered TX UI is calculated over 3500 consecutive unit intervals of sample data. Jitter is measured using all edges of the 250 consecutive UI in the center of the 3500 UI used for calculating the TX UI. See Notes 2, 3 and 4.

**Notes:**

- No test load is necessarily associated with this value.
- Specified at the measurement point and measured over any 250 consecutive UIs. The test load in Figure 50 should be used as the RX device when taking measurements. If the clocks to the RX and TX are not derived from the same reference clock, the TX UI recovered from 3500 consecutive UI must be used as a reference for the eye diagram.
- A  $T_{RX-EYE} = 0.40$  UI provides for a total sum of 0.60 UI deterministic and random jitter budget for the Transmitter and interconnect collected any 250 consecutive UIs. The  $T_{RX-EYE-MEDIAN-to-MAX-JITTER}$  specification ensures a jitter distribution in which the median and the maximum deviation from the median is less than half of the total. UI jitter budget collected over any 250 consecutive TXUIs. It should be noted that the median is not the same as the mean. The jitter median describes the point in time where the number of jitter points on either side is approximately equal as opposed to the averaged time value. If the clocks to the RX and TX are not derived from the same reference clock, the TX UI recovered from 3500 consecutive UI must be used as the reference for the eye diagram.
- It is recommended that the recovered TX UI is calculated using all edges in the 3500 consecutive UI interval with a fit algorithm using a minimization merit function. Least squares and median deviation fits have worked well with experimental and simulated data.

### 2.19.3.3 Compliance Test and Measurement Load

The AC timing and voltage parameters must be verified at the measurement point, as specified within 0.2 inches of the package pins, into a test/measurement load shown in this figure.

**NOTE**

The allowance of the measurement point to be within 0.2 inches of the package pins is meant to acknowledge that package/board routing may benefit from D+ and D– not being exactly matched in length at the package pin boundary. If the vendor does not explicitly state where the measurement point is located, the measurement point is assumed to be the D+ and D– package pins.

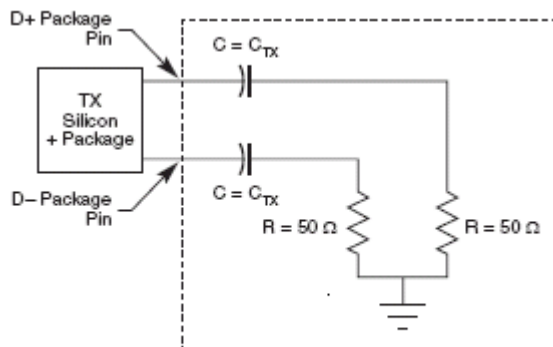
**Figure 50. Compliance Test/Measurement Load**

## 3 QUICC Engine Block Specifications

### 3.1 Ethernet Interface

This section provides the AC and DC electrical characteristics for the Ethernet interfaces inside the QUICC Engine block.

#### 3.1.1 MII and RMII DC Electrical Characteristics

This table shows the MII and RMII DC electrical characteristics

**Table 70. MII and RMII DC Electrical Characteristics**

Parameter	Symbol	Min	Max	Unit	Notes
Input high voltage	$V_{IH}$	2.0	—	V	1
Input low voltage	$V_{IL}$	—	0.8	V	—
Input high current ( $V_{IN} = BV_{DD}$ )	$I_{IH}$	—	50	$\mu A$	2
Input low current ( $V_{IN} = GND$ )	$I_{IL}$	-50	—	$\mu A$	2
Output high voltage ( $BV_{DD} = \text{Min}$ , $I_{OH} = -4.0 \text{ mA}$ )	$V_{OH}$	2.4	$BV_{DD} + 0.3$	V	—
Output low voltage ( $BV_{DD} = \text{Min}$ , $I_{OL} = 4.0 \text{ mA}$ )	$V_{OL}$	GND 0	.4	V	—

**Note:**

- Note that the min  $V_{IL}$  and max  $V_{IH}$  values are based on the respective min and max  $LV_{IN}$  values found in [Table 3](#).
- The symbol  $V_{IN}$ , in this case, represents the  $LV_{IN}$  symbols referenced in [Table 2](#) and [Table 3](#).

#### 3.1.2 MII AC Timing Specifications

This section describes the MII transmit and receive AC timing specifications.

This table provides the MII transmit AC timing specifications.

**Table 71. MII Transmit AC Timing Specifications**

For recommended operating conditions, see [Table 3](#)

Parameter/Condition	Symbol	Min	Typ	Max	Unit
TX_CLK clock period 10 Mbps	$t_{MTX}$	399.96	400	400.04	ns
TX_CLK clock period 100 Mbps	$t_{MTX}$	39.996	40	40.004	ns
TX_CLK duty cycle	$t_{MTXH}/t_{MTX}$	35	—	65	%
TX_CLK to MII data TXD[3:0], TX_ER, TX_EN delay	$t_{MTKHDX}$	1	—	15	ns
TX_CLK data clock rise (20%–80%)	$t_{MTXR}$	1.0	—	4.0	ns
TX_CLK data clock fall (80%–20%)	$t_{MTXF}$	1.0	—	4.0	ns



This figure shows the MII transmit AC timing diagram.

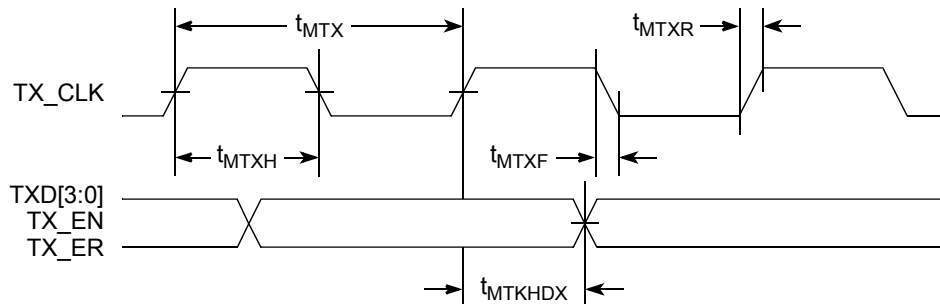

**Figure 51. MII Transmit AC Timing Diagram**

This table provides the MII receive AC timing specifications.

**Table 72. MII Receive AC Timing Specifications**

For recommended operating conditions, see [Table 3](#).

Parameter/Condition	Symbol	Min	Typ	Max	Unit
RX_CLK clock period 10 Mbps	$t_{MRX}$	399.96	400	400.04	ns
RX_CLK clock period 100 Mbps	$t_{MRX}$	39.996	40	40.004	ns
RX_CLK duty cycle	$t_{MRXH}/t_{MRX}$	35	—	65	%
RXD[3:0], RX_DV, RX_ER setup time to RX_CLK	$t_{MRDVKH}$	10.0	—	—	ns
RXD[3:0], RX_DV, RX_ER hold time to RX_CLK	$t_{MRDXKH}$	10.0	—	—	ns
RX_CLK clock rise (20%–80%)	$t_{MRXR}$	1.0	—	4.0	ns
RX_CLK clock fall time (80%–20%)	$t_{MRXF}$	1.0	—	4.0	ns

**Note:** The frequency of RX\_CLK should not exceed the frequency of TX\_CLK by more than 300 ppm.

This figure shows the MII receive AC timing diagram.

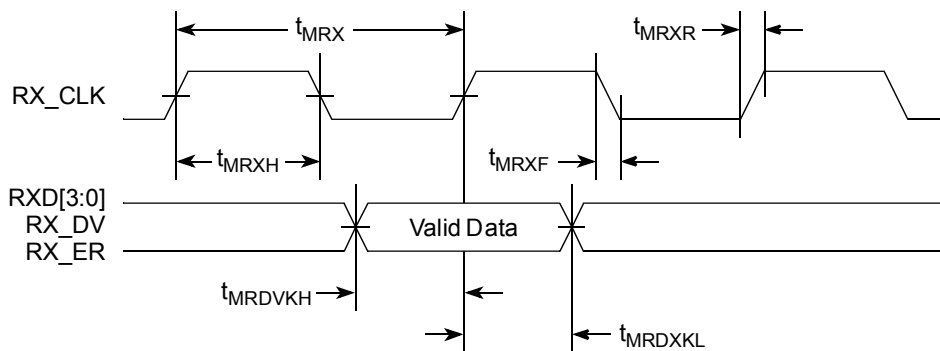

**Figure 52. MII Receive AC Timing Diagram**

## QUICC Engine Block Specifications

This figure provides the MII AC test load.

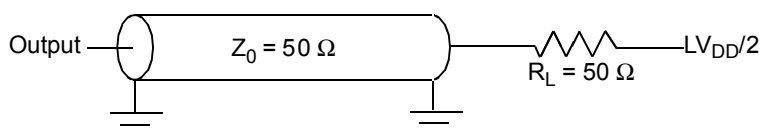

Figure 53. MII AC Test Load

### 3.1.3 RMII AC Timing Specifications

This section describes the RMII transmit and receive AC timing specifications.

The RMII transmit AC timing specifications listed are in this table.

Table 73. RMII Transmit AC Timing Specifications

For recommended operating conditions, see Table 3

Parameter	Symbol	Min	Typ	Max	Unit
REF_CLK clock period	$t_{RMT}$	—	20.0	—	ns
REF_CLK duty cycle	$t_{RMTH}$	35	—	65	%
REF_CLK peak-to-peak jitter	$t_{RMTJ}$	—	—	250	ps
Rise time REF_CLK (20%–80%)	$t_{RMTR}$	1.0	—	5.0	ns
Fall time REF_CLK (80%–20%)	$t_{RMTF}$	1.0	—	5.0	ns
REF_CLK to RMII data TXD[1:0], TX_EN delay	$t_{RMTDX}$	2.0	—	10.0	ns

This figure shows the RMII transmit AC timing diagram.

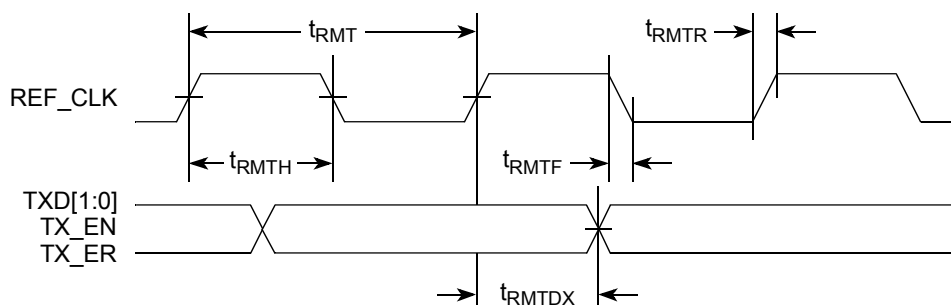

Figure 54. RMII Transmit AC Timing Diagram

This table provides the MII receive AC timing specifications.

Table 74. RMII Receive AC Timing Specifications

For recommended operating conditions, see Table 3

Parameter	Symbol	Min	Typ	Max	Unit
REF_CLK clock period	$t_{RMR}$	—	20.0	—	ns
REF_CLK duty cycle	$t_{RMRH}$	35	—	65	%
REF_CLK peak-to-peak jitter	$t_{RMRJ}$	—	—	250	ps
Rise time REF_CLK (20%–80%)	$t_{RMRR}$	1.0	—	5.0	ns

**Table 74. RMII Receive AC Timing Specifications (continued)**

For recommended operating conditions, see [Table 3](#)

Parameter	Symbol	Min	Typ	Max	Unit
Fall time REF_CLK (80%–20%)	$t_{RMRF}$	1.0	—	5.0	ns
RXD[1:0], CRS_DV, RX_ER setup time to REF_CLK rising edge	$t_{RMRDVKH}$	4.0	—	—	ns
RXD[1:0], CRS_DV, RX_ER hold time to REF_CLK rising edge	$t_{RMRKHDX}$	2.0	—	—	ns

This figure shows the RMII receive AC timing diagram.

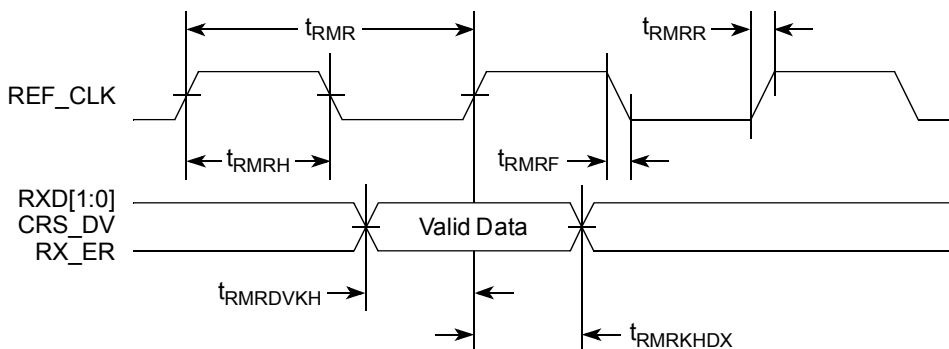

**Figure 55. RMII Receive AC Timing Diagram**

This figure provides the AC test load.

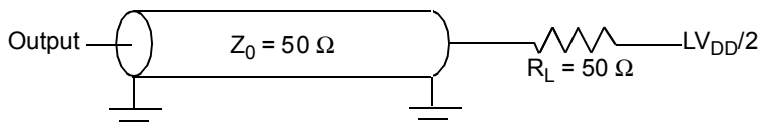

**Figure 56. AC Test Load**

## 3.2 HDLC, BISYNC, Transparent, and Synchronous UART Interfaces

This section describes the DC and AC electrical specifications for the high level data link control (HDLC), BISYNC, transparent and synchronous UART.

### 3.2.1 HDLC, BISYNC, Transparent and Synchronous UART DC Electrical Characteristics

This table provides the DC electrical characteristics for the HDLC, BISYNC, Transparent and Synchronous UART protocols.

**Table 75. HDLC, BiSync, Transparent and Synchronous UART DC Electrical Characteristics**

For recommended operating conditions, see [Table 3](#).

Parameter	Symbol	Min	Max	Unit	Notes
Input high voltage	$V_{IH}$	2.0	—	V	1
Input low voltage	$V_{IL}$	—	0.8	V	1
Input current ( $BV_{IN} = 0\text{ V}$ or $BV_{IN} = BV_{DD}$ )	$I_{IN}$	—	$\pm 50$	$\mu\text{A}$	2

## QUICC Engine Block Specifications

**Table 75. HDLC, BiSync, Transparent and Synchronous UART DC Electrical Characteristics (continued)**

For recommended operating conditions, see [Table 3](#).

Parameter	Symbol	Min	Max	Unit	Notes
Output high voltage ( $BV_{DD} = \text{min}$ , $I_{OH} = -2 \text{ mA}$ )	$V_{OH}$	2.4	—	V	—
Output low voltage ( $BV_{DD} = \text{min}$ , $I_{OH} = 2 \text{ mA}$ )	$V_{OL}$	—	0.4	V	—

**Note:**

- Note that the min  $V_{IL}$  and max  $V_{IH}$  values are based on the respective min and max  $BV_{IN}$  values found in [Table 3](#).
- Note that the symbol  $BV_{IN}$  represents the input voltage of the supply. It is referenced in [Table 3](#).

### 3.2.2 HDLC, BISYNC, Transparent and Synchronous UART AC Timing Specifications

This table provides the input and output AC timing specifications for HDLC, BiSync, and Transparent and Synchronous UART protocols.

**Table 76. HDLC, BiSync, Transparent AC Timing Specifications**

For recommended operating conditions, see [Table 3](#).

Parameter	Symbol <sup>1</sup>	Min	Max	Unit	Notes
Outputs—Internal clock delay	$t_{HIKHOV}$	0	5.5	ns	2
Outputs—External clock delay	$t_{HEKHOV}$	1	8	ns	2
Outputs—Internal clock High Impedance	$t_{HIKHOX}$	0	5.5	ns	2
Outputs—External clock High Impedance	$t_{HEKHOX}$	1	8	ns	2
Inputs—Internal clock input setup time	$t_{HIIVKH}$	6	—	ns	—
Inputs—External clock input setup time	$t_{HEIVKH}$	4	—	ns	—
Inputs—Internal clock input Hold time	$t_{HIIXKH}$	0	—	ns	—
Inputs—External clock input hold time	$t_{HEIXKH}$	1	—	ns	—

**Notes:**

- The symbols used for timing specifications follow the pattern  $t_{(\text{first two letters of functional block})(\text{signal})(\text{state})(\text{reference})(\text{state})}$  for inputs and  $t_{(\text{first two letters of functional block})(\text{reference})(\text{state})(\text{signal})(\text{state})}$  for outputs. For example,  $t_{HIKHOX}$  symbolizes the outputs internal timing (HI) for the time  $t_{\text{serial}}$  memory clock reference (K) goes from the high state (H) until outputs (O) are invalid (X).
- Output specifications are measured from the 50% level of the rising edge of CLKIN to the 50% level of the signal. Timings are measured at the pin.

This table provides the input and output AC timing specifications for the synchronous UART protocols.

**Table 77. Synchronous UART AC Timing Specifications**

For recommended operating conditions, see [Table 3](#)

Parameter	Symbol <sup>1</sup>	Min	Max	Unit	Notes
Outputs—Internal clock delay	$t_{HIKHOV}$	0	11	ns	2
Outputs—External clock delay	$t_{HEKHOV}$	1	14	ns	2
Outputs—Internal clock High Impedance	$t_{HIKHOX}$	0	11	ns	2

**Table 77. Synchronous UART AC Timing Specifications (continued)**

For recommended operating conditions, see Table 3

Parameter	Symbol <sup>1</sup>	Min	Max	Unit	Notes
Outputs—External clock High Impedance	$t_{HEKHOX}$	1	14	ns	2
Inputs—Internal clock input setup time	$t_{HIIVKH}$	10	—	ns	—
Inputs—External clock input setup time	$t_{HEIVKH}$	8	—	ns	—
Inputs—Internal clock input Hold time	$t_{HIIXKH}$	0	—	ns	—
Inputs—External clock input hold time	$t_{HEIXKH}$	1	—	ns	—

**Notes:**

1. Output specifications are measured from the 50% level of the rising edge of CLKIN to the 50% level of the signal. Timings are measured at the pin.
2. The symbols used for timing specifications follow the pattern of  $t_{(first\ two\ letters\ of\ functional\ block)(signal)(state)\ (reference)(state)}$  for inputs and  $t_{(first\ two\ letters\ of\ functional\ block)(reference)(state)(signal)(state)}$  for outputs. For example,  $t_{HIIXKH}$  symbolizes the outputs internal timing (HI) for the time  $t_{serial}$  memory clock reference (K) goes from the high state (H) until outputs (O) are invalid (X).

This figure provides the AC test load.

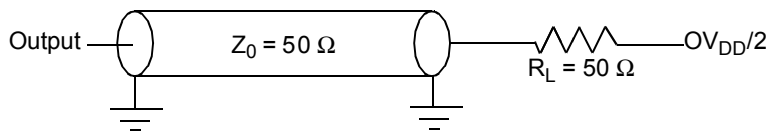

**Figure 57. AC Test Load**

These figures represent the AC timing from Table 76 and Table 77. Note that although the specifications generally reference the rising edge of the clock, these AC timing diagrams also apply when the falling edge is the active edge. This figure shows the timing with external clock.

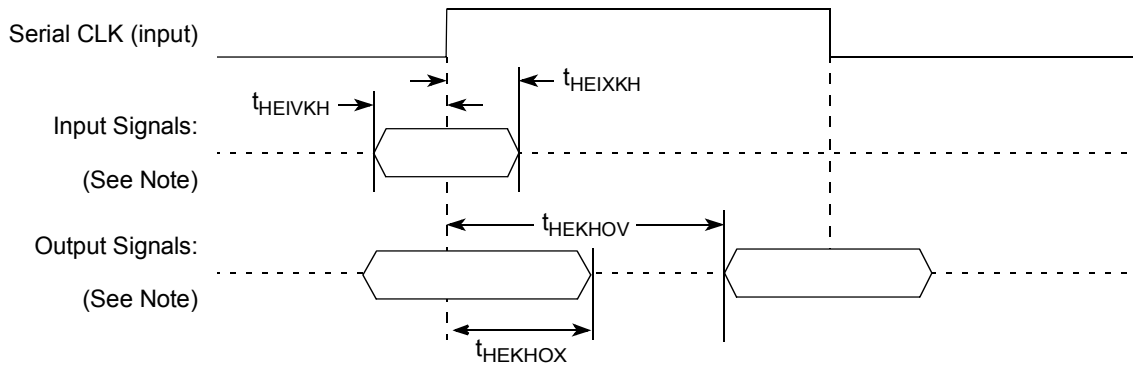

**Note:** The clock edge is selectable

**Figure 58. AC Timing (External Clock) Diagram**

## QUICC Engine Block Specifications

This figure shows the timing with internal clock.

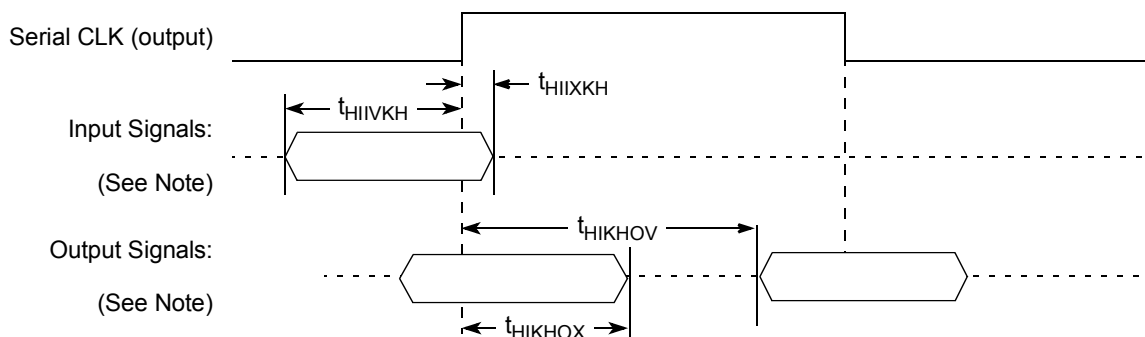

**Note:** The clock edge is selectable

**Figure 59. AC Timing (Internal Clock) Diagram**

## 3.3 TDM/SI

This section describes the DC and AC electrical specifications for the time-division-multiplexed and serial interface (TDM/SI).

### 3.3.1 TDM/SI DC Electrical Characteristics

This table provides the TDM/SI DC electrical characteristics.

**Table 78. TDM/SI DC Electrical Characteristics**

For recommended operating conditions, see [Table 3](#).

Parameter	Symbol	Min	Max	Unit	Notes
Input high voltage	$V_{IH}$	2.0	—	V	1
Input low voltage	$V_{IL}$	—	0.8	V	1
Input current ( $BV_{IN} = 0$ V or $BV_{IN} = BV_{DD}$ )	$I_{IN}$	—	$\pm 50$	$\mu$ A	2
Output high voltage ( $BV_{DD} = \text{min}$ , $I_{OH} = -2$ mA)	$V_{OH}$	2.4	—	V	—
Output low voltage ( $BV_{DD} = \text{min}$ , $I_{OH} = 2$ mA)	$V_{OL}$	—	0.4	V	—

**Note:**

- Note that the min  $V_{IL}$  and max  $V_{IH}$  values are based on the respective min and max  $BV_{IN}$  values found in [Table 3](#).
- Note that the symbol  $BV_{IN}$  represents the input voltage of the supply. It is referenced in [Table 3](#).

### 3.3.2 TDM/SI AC Timing Specifications

This table provides the TDM/SI input and output AC timing specifications.

**Table 79. TDM/SI AC Timing Specifications <sup>1</sup>**

Parameter	Symbol <sup>2</sup>	Min	Max	Unit
TDM/SI outputs—External clock delay	$t_{SEKHOV}$	2	11	ns
TDM/SI outputs—External clock High Impedance	$t_{SEKHOX}$	2	10	ns
TDM/SI inputs—External clock input setup time	$t_{SEIVKH}$	5	—	ns

**Table 79. TDM/SI AC Timing Specifications <sup>1</sup>**

Parameter	Symbol <sup>2</sup>	Min	Max	Unit
TDM/SI inputs—External clock input hold time	$t_{SEIXKH}$	2	—	ns

**Notes:**

1. Output specifications are measured from the 50% level of the rising edge of CLKIN to the 50% level of the signal. Timings are measured at the pin.
2. The symbols used for timing specifications follow the pattern of  $t_{(first\ two\ letters\ of\ functional\ block)(signal)(state)\ (reference)(state)}$  for inputs and  $t_{(first\ two\ letters\ of\ functional\ block)(reference)(state)(signal)(state)}$  for outputs. For example,  $t_{SEKHOX}$  symbolizes the TDM/SI outputs external timing (SE) for the time  $t_{TDM/SI}$  memory clock reference (K) goes from the high state (H) until outputs (O) are invalid (X).

This figure provides the AC test load for the TDM/SI.

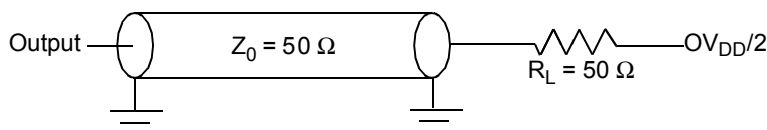

**Figure 60. TDM/SI AC Test Load**

This figure represents the AC timing from Table 79. Note that although the specifications generally reference the rising edge of the clock, these AC timing diagrams also apply when the falling edge is the active edge. This figure shows the TDM/SI timing with external clock.

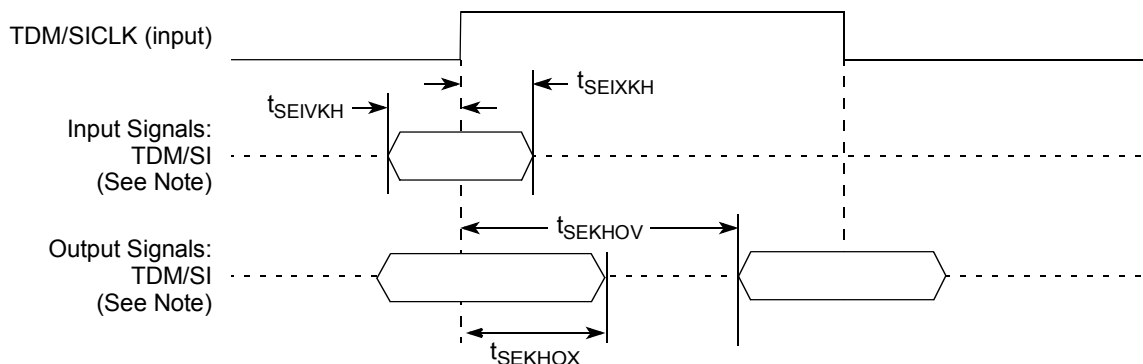

**Note:** The clock edge is selectable on TDM/SI

**Figure 61. TDM/SI AC Timing (External Clock) Diagram**

### 3.4 UTOPIA Interface

This section describes the DC and AC electrical specifications for the UTOPIA.

#### 3.4.1 UTOPIA DC Electrical Characteristics

This table provides the DC electrical characteristics for the UTOPIA.

**Table 80. UTOPIA DC Electrical Characteristics**

For recommended operating conditions, see [Table 3](#).

Parameter	Symbol	Min	Max	Unit	Notes
Input high voltage	$V_{IH}$	2.0	—	V	1
Input low voltage	$V_{IL}$	—	0.8	V	1
Input current ( $BV_{IN} = 0\text{ V}$ or $BV_{IN} = BV_{DD}$ )	$I_{IN}$	—	$\pm 50$	$\mu\text{A}$	2
Output high voltage ( $BV_{DD} = \text{min}$ , $I_{OH} = -2\text{ mA}$ )	$V_{OH}$	2.4	—	V	—
Output low voltage ( $BV_{DD} = \text{min}$ , $I_{OH} = 2\text{ mA}$ )	$V_{OL}$	—	0.4	V	—

**Note:**

- Note that the min  $V_{IL}$  and max  $V_{IH}$  values are based on the respective min and max  $BV_{IN}$  values found in [Table 3](#).
- Note that the symbol  $BV_{IN}$  represents the input voltage of the supply. It is referenced in [Table 3](#).

### 3.4.2 UTOPIA AC Timing Specifications

This table provides the UTOPIA input and output AC timing specifications.

**Table 81. UTOPIA AC Timing Specifications<sup>1</sup>**

Parameter	Symbol <sup>2</sup>	Min	Max	Unit
UTOPIA/POS outputs—Internal clock delay	$t_{UIKHOV}$	0	8	ns
UTOPIA/POS outputs—External clock delay	$t_{UEKHOV}$	1	10	ns
UTOPIA/POS outputs—Internal clock High Impedance	$t_{UIKHOX}$	0	8	ns
UTOPIA/POS outputs—External clock High Impedance	$t_{UEKHOX}$	1	10	ns
UTOPIA/POS inputs—Internal clock input setup time	$t_{UIIVKH}$	6	—	ns
UTOPIA/POS inputs—External clock input setup time	$t_{UEIVKH}$	4	—	ns
UTOPIA/POS inputs—Internal clock input Hold time	$t_{UIIXKH}$	0	—	ns
UTOPIA/POS inputs—External clock input hold time	$t_{UEIXKH}$	1	—	ns

**Notes:**

- Output specifications are measured from the 50% level of the rising edge of CLKIN to the 50% level of the signal. Timings are measured at the pin.
- The symbols used for timing specifications follow the pattern of  $t_{(\text{first two letters of functional block})(\text{signal})(\text{state})(\text{reference})(\text{state})}$  for inputs and  $t_{(\text{first two letters of functional block})(\text{reference})(\text{state})(\text{signal})(\text{state})}$  for outputs. For example,  $t_{UIKHOX}$  symbolizes the UTOPIA/POS outputs internal timing (UI) for the time  $t_{\text{Utopia}}$  memory clock reference (K) goes from the high state (H) until outputs (O) are invalid (X).

This figure provides the AC test load for the UTOPIA.

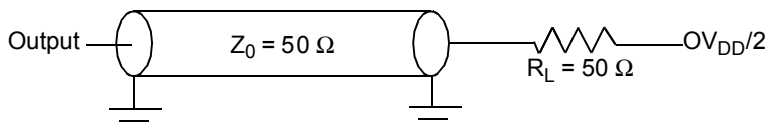

**Figure 62. UTOPIA AC Test Load**



These figures represent the AC timing from [Table 81](#). Note that although the specifications generally reference the rising edge of the clock, these AC timing diagrams also apply when the falling edge is the active edge.

This figure shows the UTOPIA timing with external clock.

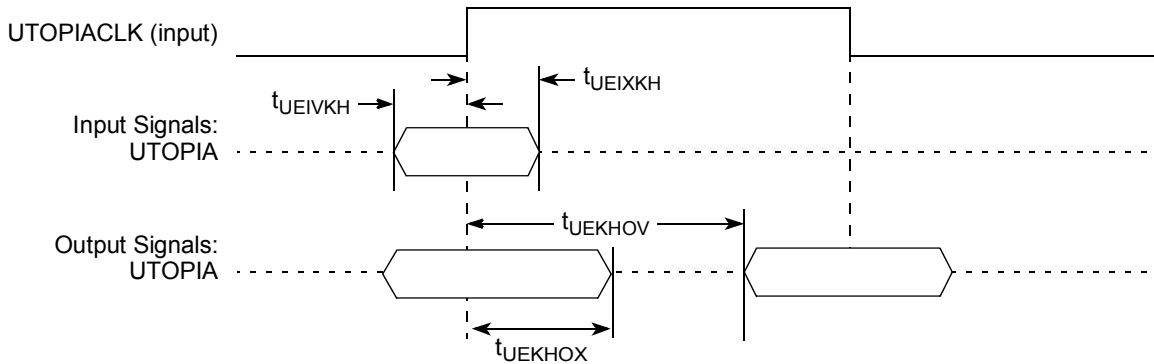

Figure 63. UTOPIA AC Timing (External Clock) Diagram

This figure shows the UTOPIA timing with internal clock.

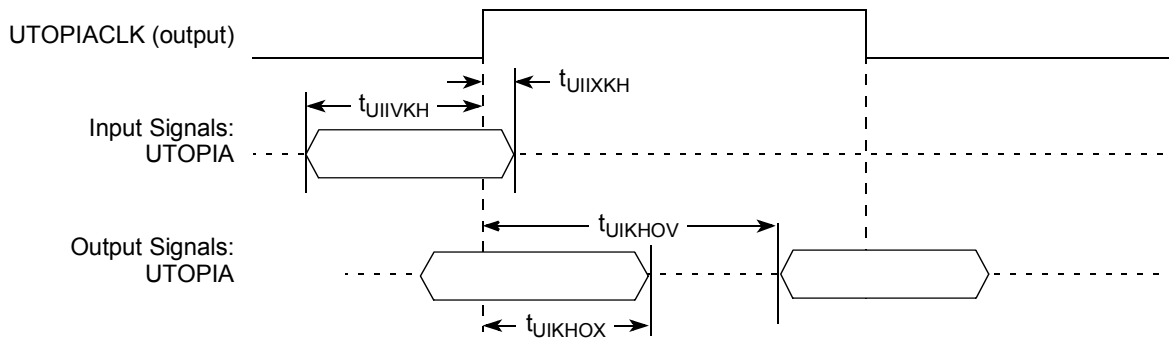

Figure 64. UTOPIA AC Timing (Internal Clock) Diagram

### 3.5 SPI Interface

This section describes the SPI DC and AC electrical specifications.

#### 3.5.1 SPI DC Electrical Characteristics

This table provides the SPI DC electrical characteristics.

Table 82. SPI DC Electrical Characteristics

For recommended operating conditions, see [Table 3](#)

Parameter	Symbol	Min	Max	Unit	Notes
Input high voltage	$V_{IH}$	2.0	—	V	1
Input low voltage	$V_{IL}$	—	0.8	V	1

**Table 82. SPI DC Electrical Characteristics (continued)**

For recommended operating conditions, see [Table 3](#)

Parameter	Symbol	Min	Max	Unit	Notes
Input current ( $OV_{IN} = 0\text{ V}$ or $OV_{IN} = OV_{DD}$ )	$I_{IN}$	—	$\pm 50$	$\mu\text{A}$	2
Output high voltage ( $OV_{DD} = \text{min}$ , $I_{OH} = -2\text{ mA}$ )	$V_{OH}$	2.4	—	V	—
Output low voltage ( $OV_{DD} = \text{min}$ , $I_{OH} = 2\text{ mA}$ )	$V_{OL}$	—	0.4	V	—

**Note:**

1. The min  $V_{IL}$  and max  $V_{IH}$  values are based on the respective min and max  $OV_{IN}$  values found in [Table 3](#).
2. The symbol  $OV_{IN}$  represents the input voltage of the supply. It is referenced in [Table 3](#).

### 3.5.2 SPI AC Timing Specifications

This table and provide the SPI input and output AC timing specifications.

**Table 83. SPI AC Timing Specifications**

For recommended operating conditions, see [Table 3](#).

Parameter	Symbol <sup>1</sup>	Min	Max	Unit	Note
SPI outputs valid—Master mode (internal clock) delay	$t_{NIKHOV}$	—	6	ns	2
SPI outputs hold—Master mode (internal clock) delay	$t_{NIKHOX}$	0.5	—	ns	2
SPI outputs valid—Slave mode (external clock) delay	$t_{NEKHOV}$	—	9	ns	2
SPI outputs hold—Slave mode (external clock) delay	$t_{NEKHOX}$	2	—	ns	2
SPI inputs—Master mode (internal clock) input setup time	$t_{NIIVKH}$	4	—	ns	—
SPI inputs—Master mode (internal clock) input hold time	$t_{NIIXKH}$	0	—	ns	—
SPI inputs—Slave mode (external clock) input setup time	$t_{NEIVKH}$	4	—	ns	—
SPI inputs—Slave mode (external clock) input hold time	$t_{NEIXKH}$	2	—	ns	—

**Note:**

- 1 The symbols used for timing specifications follow the pattern of  $t_{(\text{first two letters of functional block})(\text{signal})(\text{state})(\text{reference})(\text{state})}$  for inputs and  $t_{(\text{first two letters of functional block})(\text{reference})(\text{state})(\text{signal})(\text{state})}$  for outputs. For example,  $t_{NIKHOX}$  symbolizes the internal timing (NI) for the time SPICLK clock reference (K) goes to the high state (H) until outputs (O) are invalid (X).
2. Output specifications are measured from the 50% level of the rising edge of CLKIN to the 50% level of the signal. Timings are measured at the pin.

This figure provides the AC test load for the SPI.

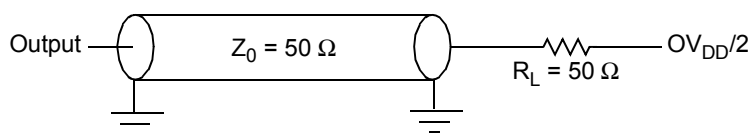

**Figure 65. SPI AC Test Load**

These figures represent the AC timing from Table 30. Note that although the specifications generally reference the rising edge of the clock, these AC timing diagrams also apply when the falling edge is the active edge.

This figure shows the SPI timing in slave mode (external clock).

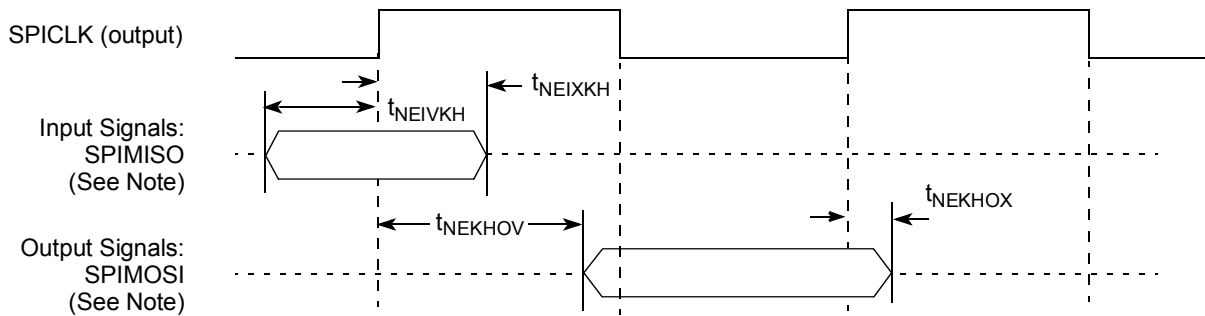

**Note:** The clock edge is selectable on SPI.

**Figure 66. SPI AC Timing in Slave Mode (External Clock) Diagram**

This figure shows the SPI timing in master mode (internal clock).

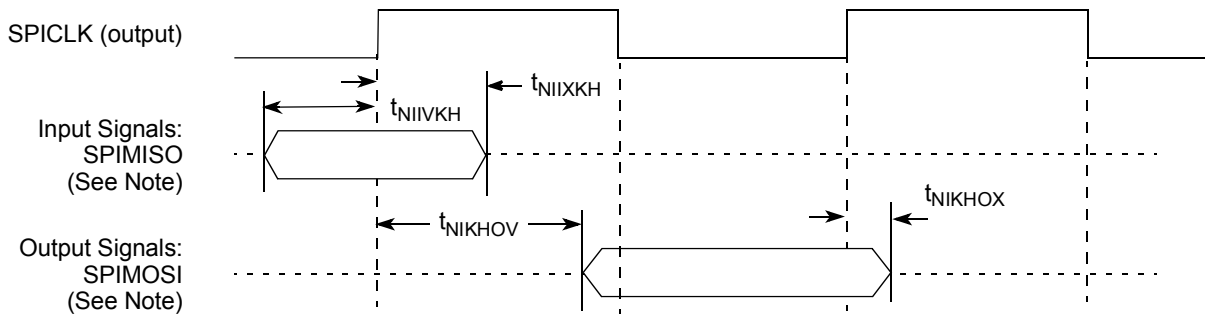

**Note:** The clock edge is selectable on SPI.

**Figure 67. SPI AC Timing in Master Mode (Internal Clock) Diagram**

## 3.6 GPIO

This section describes the DC and AC electrical characteristics for the GPIO interface.

### 3.6.1 GPIO DC Electrical Characteristics

This table provides the DC electrical characteristics for the GPIO interface when operating from a 3.3 V supply.

**Table 84. GPIO DC Electrical Characteristics (3.3 V)**

For recommended operating conditions, see Table 3

Parameter	Symbol	Min	Max	Unit	Notes
Input high voltage	$V_{IH}$	2	—	V	1
Input low voltage	$V_{IL}$	—	0.8	V	1

**Table 84. GPIO DC Electrical Characteristics (3.3 V) (continued)**

For recommended operating conditions, see [Table 3](#)

Parameter	Symbol	Min	Max	Unit	Notes
Input current ( $OV_{IN} = 0\text{ V}$ or $OV_{IN} = OV_{DD}$ ) $I$	$I_{IN}$	—	$\pm 50$	$\mu\text{A}$	2
Output high voltage ( $OV_{DD} = \text{min}$ , $I_{OH} = -2\text{ mA}$ )	$V_{OH}$	2.4	—	V	—
Output low voltage ( $OV_{DD} = \text{min}$ , $I_{OL} = 2\text{ mA}$ )	$V_{OL}$	—	0.4	V	—

**Note:**

1. The min  $V_{IL}$  and max  $V_{IH}$  values are based on the min and max  $OV_{IN}$  respective values found in [Table 3](#).
2. The symbol  $OV_{IN}$  represents the input voltage of the supply. It is referenced in [Table 3](#).

### 3.6.2 GPIO AC Timing Specifications

This table provides the GPIO input and output AC timing specifications.

**Table 85. GPIO Input AC Timing Specifications**

For recommended operating conditions, see [Table 3](#)

Parameter	Symbol	Min	Unit	Notes
GPIO inputs—minimum pulse width	$t_{PIWID}$	20	ns	1

**Notes:**

1. GPIO inputs and outputs are asynchronous to any visible clock. GPIO outputs should be synchronized before use by any external synchronous logic. GPIO inputs are required to be valid for at least  $t_{PIWID}$  to ensure proper operation.

This figure provides the AC test load for the GPIO.

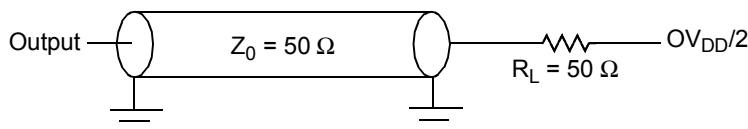

**Figure 68. GPIO AC Test Load**

## 4 Thermal

This section describes the thermal specifications.

### 4.1 Thermal Characteristics

This table provides the package thermal characteristics.

**Table 86. Package Thermal Characteristics**

Parameter	JEDEC Board	Symbol	Value	Unit	Notes
Junction-to-ambient Natural Convection	Single layer board (1s)	$R_{\theta JA}$	23	$^{\circ}\text{C/W}$	1, 2
Junction-to-ambient Natural Convection	Four layer board (2s2p)	$R_{\theta JA}$	17	$^{\circ}\text{C/W}$	1, 2
Junction-to-ambient (at 200 ft/min)	Single layer board (1s)	$R_{\theta JA}$	18	$^{\circ}\text{C/W}$	1, 2
Junction-to-ambient (at 200 ft/min)	Four layer board (2s2p)	$R_{\theta JA}$	14	$^{\circ}\text{C/W}$	1, 2
Junction-to-board thermal	—	$R_{\theta JB}$	9	$^{\circ}\text{C/W}$	3

**Table 86. Package Thermal Characteristics**

Parameter	JEDEC Board	Symbol	Value	Unit	Notes
Junction-to-case thermal	—	$R_{\theta JC}$	7	°C/W	4
Junction-to-package top thermal	Natural Convection	$\Psi_{JT}$	7	°C/W	5

**Notes**

1. Junction temperature is a function of die size, on-chip power dissipation, package thermal resistance, mounting site (board) temperature, ambient temperature, air flow, power dissipation of other components on the board, and board thermal resistance.
2. Per JEDEC JESD51-2 and JESD51-6 with the board (JESD51-9) horizontal.
3. Thermal resistance between the die and the printed-circuit board per JEDEC JESD51-8. Board temperature is measured on the top surface of the board near the package.
4. Junction-to-case at the top of the package determined using MIL-STD 883 Method 1012.1. The cold plate temperature is used for the case temperature. Reported value includes the thermal resistance of the interface layer.
5. Thermal characterization parameter indicating the temperature difference between package top and the junction temperature per JEDEC JESD51-2. When Greek letters are not available, the thermal characterization parameter is written as Psi-JT.

## 4.2 Temperature Diode

The device have a thermal diode on the microprocessor that can be used in conjunction with other system temperature monitoring devices (such as On Semiconductor, NCT1008™). These devices use the negative temperature coefficient of a diode operated at a constant current to determine the temperature of the microprocessor and its environment.

The following are the specifications of the P1012 on-board temperature diode:

Operating range: 10 – 230  $\mu$  A

Ideality factor over 13.5 – 220  $\mu$  A;  $n = 1.006 \pm 0.008$

# 5 Package Information

This section provides the package parameters and ordering information.

## 5.1 Package Parameters for the P1012 WB-TePBGA II

The package parameters are provided in the following list. The package type is 31 mm  $\times$  31 mm, 689 plastic ball grid array (WB-TePBGA II).

Package outline	31 mm $\times$ 31 mm
Interconnects	689
Pitch	1.00 mm
Module height	2.0 mm to 2.46 mm (Maximum)
Solder Balls	3.5% Ag, 96.5% Sn
Ball diameter (typical)	0.60 mm

## Package Information

This figure shows the P1012 package.

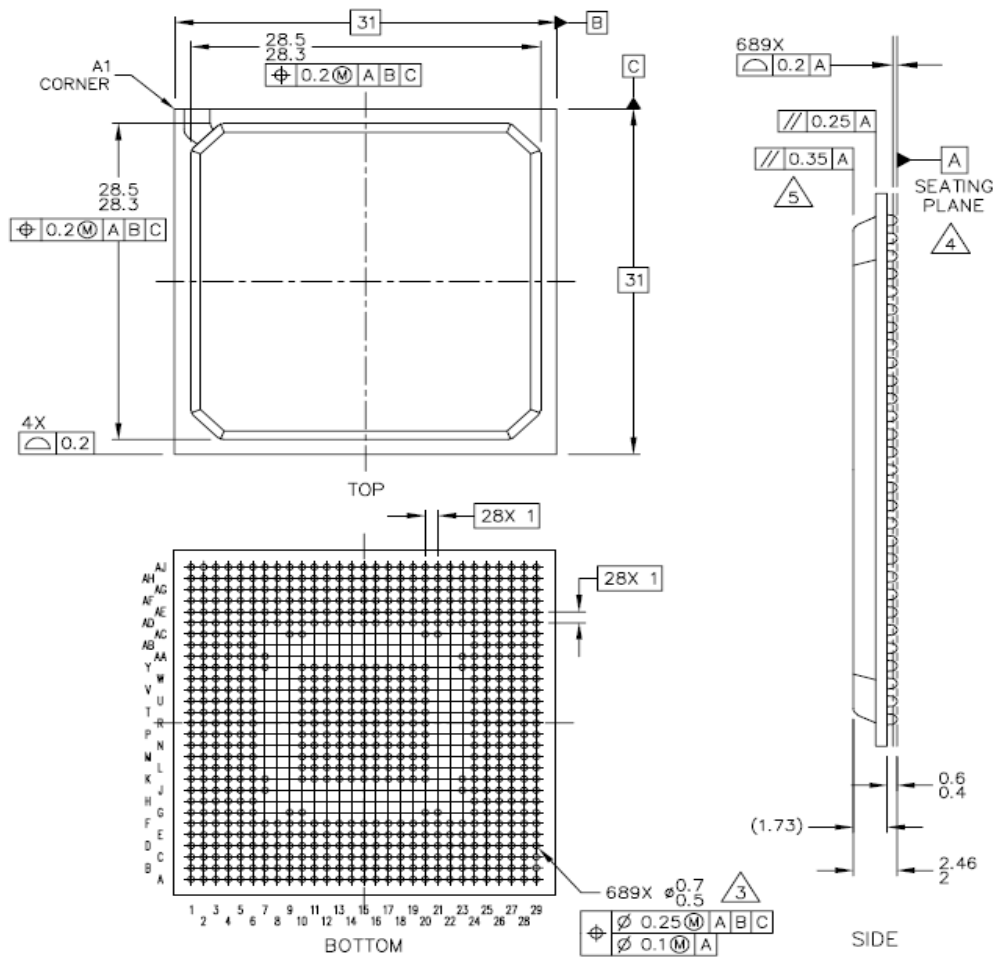

**Figure 69. P1012 Package**

### NOTES for Figure 69:

1. All dimensions are in millimeters.
2. Dimensioning and tolerancing per ASME Y14. 5M-1994.
3. Maximum solder ball diameter measured parallel to Datum A.
4. Datum A, the seating plane, is determined by the spherical crowns of the solder balls.
5. Parallelism measurement shall exclude any effect of mark on top surface of package.

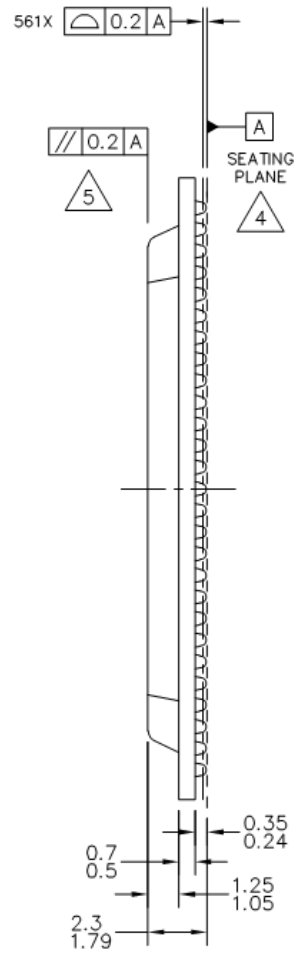
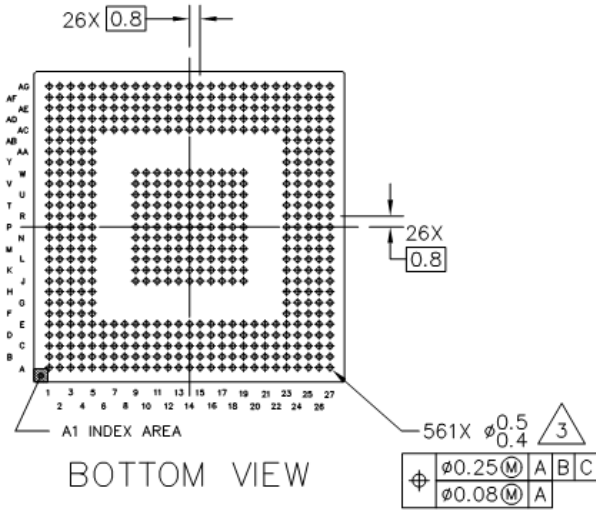
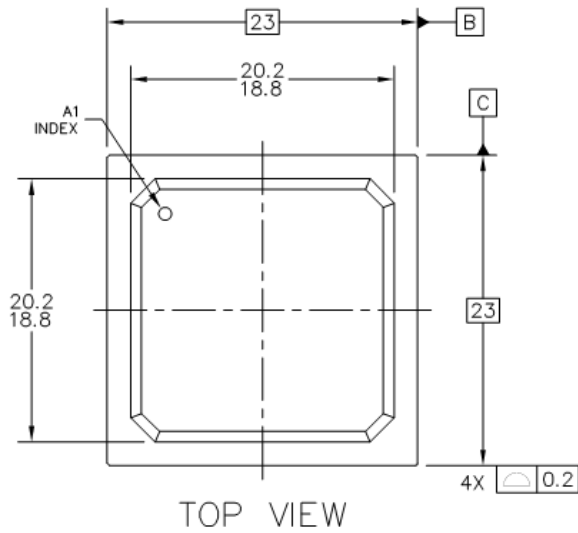

Notes:

1. All dimensions are in millimeters.
2. Dimensioning and tolerancing per ASME Y14. 5M-1994.
3. Maximum solder ball diameter measured parallel to Datum A.
4. Datum A, the seating plane, is determined by the spherical crowns of the solder balls.
5. Parallelism measurement shall exclude any effect of mark on top surface of package.

## 5.2 Ordering Information

This table provides the Freescale part numbering nomenclature. Each part number also contains a revision code which refers to the die mask revision number.

**Table 87. Part Numbering Nomenclature**

P	1	02 or 01	2	q	t	e	n	dd	r
Generat ion	Platform	Number of Cores	Deriva tive	Qual Status	Temperature Range	Encryptio n	Package Type	CPU/CCB/DDR Frequency (MHz)	Die Revisio n
P = 45 nm	1	01 =Single Core 02 = Dual Core	0-9	P = Prototype N = Qual'd to Industrial Tier S = Special	S = Std Temp X = Ext. Temp	E = SEC Present N = SEC Not Present	2 = TePBGA II Pbfree	HF = 800/400/667 FF = 667/333/667 DF = 533/267/667	A = 1.0 B = 1.1

**Notes:**

1. See [Section 5, "Package Information,"](#) for more information on available package types.
2. Processor core frequencies supported by parts addressed by this specification only. Not all parts described in this specification support all core frequencies. Additionally, parts addressed by part number specifications may support other maximum core frequencies. The QUICC Engine RISC clock speed is equal to the CCB/Platform speed.

Parts are marked as the example shown in this figure.

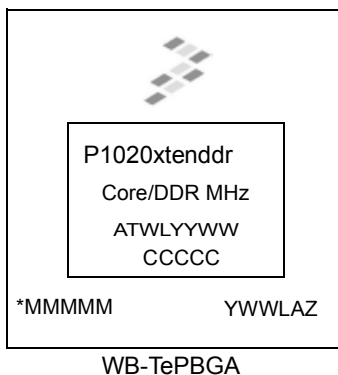

**Notes:**

- P1020xtenddr is the orderable part number
- \*MMMMM is the mask number
- YWWLAZ is the assembly traceability code.
- CCCCC is the country code
- ATWLYYWW is the standard assembly, test, year, and work week codes.

**Figure 70. Part Marking for WB-TePBGA II Device**

## 6 Product Documentation

The following documents are required for a complete description of the device and are needed to design properly with the part:

- *P1021 QorIQ Integrated Processor Reference Manual* (document number P1021RM)
- e500 PowerPC Core Reference Manual (E500CORERM)
- QUICC Engine™ Block Reference Manual (QEIWRM)



## 7 Revision History

This table provides revision history for this document.

**Table 88. Document Revision History**

Rev. Number	Date	Substantive Change(s)
1	03/2012	<ul style="list-style-type: none"> <li>• r1 <a href="#">Table 1</a>, replaced the signals NC107, NC108, and NC109 (along with their details, such as Package Pin Number, Pin Type, and Power Supply) with the signals CKSTP_IN1_B, CKSTP_OUT1_B, and READY_P1 respectively.</li> <li>• Changed the power supply from XVDD_SRDS to SVDD_SRDS for all SD_RX_n pins as well as SD_REF_CLK and SD_REF_CLK_B in <a href="#">Table 1</a>.</li> <li>• Changed Note 13 in <a href="#">Table 1</a>. The note says "These pins must NOT be pulled down by a resistor or the component they are connected to during power-on reset".</li> <li>• Added IRQ06 with CE_PB10 in <a href="#">Table 1</a>.</li> <li>• Added <a href="#">Table 18</a>.</li> <li>• r1 <a href="#">Table 30</a>, made the following changes:                             <ul style="list-style-type: none"> <li>• Changed the min value of 'SPI outputs—Master data (internal clock) hold time' from 0.5 to the formula: <math>0.5 + (t_{\text{PLATFORM\_CLK}} * \text{SPMODE} [\text{HO\_ADJ}])</math>.</li> <li>• Changed the max value of 'SPI outputs—Master data (internal clock) delay' from 6.0 to the formula: <math>0.5 + (t_{\text{PLATFORM\_CLK}} * \text{SPMODE} [\text{HO\_ADJ}])</math>.</li> <li>• Added note 3 that reads: See the P1025 QorIQ Integrated Processor Reference Manual for detail about the register SPMODE.</li> </ul> </li> <li>• r1 <a href="#">Table 41</a>, changed "LSTS = 0" to "LSTS = 001" and changed "LSTS = 1" to "LSTS = 100"</li> <li>• r1 <a href="#">Table 41</a>, changed note 4 to "The LSTS shown in the table refers to the EIC2[0:2] or EIC3[0:2] bit field of the GUTS_SRDSR4 register, depending on the SerDes lane usage"</li> <li>• Modified <a href="#">Figure 21</a>.</li> <li>• Changed value of minimum AC coupling capacitor from 5nF to 10nF and removed typical value of 100nF in <a href="#">Table 42</a>.</li> <li>• Changed min frequency of DRCLK from 66.7Mhz to 66.66MHz.</li> <li>• Changed pin E16 from NC20 to THERM1 (Internal Diode Anode) and pin E15 from NC21 to THERM0 (Internal Diode Cathode) and added Note 26 in <a href="#">Table 1</a>. Also added THERM0 and THERM1 in ball map.</li> <li>• Added <a href="#">Section 4.2, "Temperature Diode"</a>.</li> <li>• Updated <a href="#">Figure 14</a>.</li> <li>• Removed "Measured at 1.6 V" from "SD_REF_CLK/ SD_REF_CLK reference clock duty cycle" cell of <a href="#">Table 65</a>.</li> <li>• r1 <a href="#">Table 49</a>, changed min value of <math>t_{\text{T1588CLK}}</math> from 3.8 to 5.</li> <li>• Added <a href="#">Section 2.11.6.1, "eTSEC IEEE Std 1588 DC Electrical Characteristics"</a>.</li> <li>• Changed input leakage current of all interfaces to +50uA.</li> </ul>
0	08/2011	Initial release

## How to Reach Us:

### Home Page:

[www.freescale.com](http://www.freescale.com)

### Web Support:

<http://www.freescale.com/support>

### USA/Europe or Locations Not Listed:

Freescale Semiconductor, Inc.  
Technical Information Center, EL516  
2100 East Elliot Road  
Tempe, Arizona 85284  
1-800-521-6274 or  
+1-480-768-2130  
[www.freescale.com/support](http://www.freescale.com/support)

### Europe, Middle East, and Africa:

Freescale Halbleiter Deutschland GmbH  
Technical Information Center  
Schatzbogen 7  
81829 Muenchen, Germany  
+44 1296 380 456 (English)  
+46 8 52200080 (English)  
+49 89 92103 559 (German)  
+33 1 69 35 48 48 (French)  
[www.freescale.com/support](http://www.freescale.com/support)

### Japan:

Freescale Semiconductor Japan Ltd.  
Headquarters  
ARCO Tower 15F  
1-8-1, Shimo-Meguro, Meguro-ku  
Tokyo 153-0064  
Japan  
0120 191014 or  
+81 3 5437 9125  
[support.japan@freescale.com](mailto:support.japan@freescale.com)

### Asia/Pacific:

Freescale Semiconductor China Ltd.  
Exchange Building 23F  
No. 118 Jianguo Road  
Chaoyang District  
Beijing 100022  
China  
+86 10 5879 8000  
[support.asia@freescale.com](mailto:support.asia@freescale.com)

Information in this document is provided solely to enable system and software implementers to use Freescale Semiconductor products. There are no express or implied copyright licenses granted hereunder to design or fabricate any integrated circuits or integrated circuits based on the information in this document.

Freescale Semiconductor reserves the right to make changes without further notice to any products herein. Freescale Semiconductor makes no warranty, representation or guarantee regarding the suitability of its products for any particular purpose, nor does Freescale Semiconductor assume any liability arising out of the application or use of any product or circuit, and specifically disclaims any and all liability, including without limitation consequential or incidental damages. "Typical" parameters which may be provided in Freescale Semiconductor data sheets and/or specifications can and do vary in different applications and actual performance may vary over time. All operating parameters, including "Typicals" must be validated for each customer application by customer's technical experts. Freescale Semiconductor does not convey any license under its patent rights nor the rights of others. Freescale Semiconductor products are not designed, intended, or authorized for use as components in systems intended for surgical implant into the body, or other applications intended to support or sustain life, or for any other application in which the failure of the Freescale Semiconductor product could create a situation where personal injury or death may occur. Should Buyer purchase or use Freescale Semiconductor products for any such unintended or unauthorized application, Buyer shall indemnify and hold Freescale Semiconductor and its officers, employees, subsidiaries, affiliates, and distributors harmless against all claims, costs, damages, and expenses, and reasonable attorney fees arising out of, directly or indirectly, any claim of personal injury or death associated with such unintended or unauthorized use, even if such claim alleges that Freescale Semiconductor was negligent regarding the design or manufacture of the part.

Freescale, the Freescale logo, CodeWarrior, ColdFire, PowerQUICC, QorIQ, StarCore, and Symphony are trademarks of Freescale Semiconductor, Inc., Reg. U.S. Pat. & Tm. Off. CoreNet, QorIQ Qonverge, QUICC Engine, and VortiQa are trademarks of Freescale Semiconductor, Inc. All other product or service names are the property of their respective owners.

© 2012 Freescale Semiconductor, Inc.

Document Number: P1012EC

Rev. 1  
03/2012



## X-ON Electronics

Largest Supplier of Electrical and Electronic Components

*Click to view similar products for [Microprocessors - MPU category](#):*

*Click to view products by [NXP manufacturer](#):*

Other Similar products are found below :

[A2C00010998 A](#) [ALXD800EEXJCVD C3](#) [A2C00010729 A](#) [T1022NSE7MQB](#) [TS68040MF33A](#) [MPC8313EVRADDC](#)  
[BOXSTCK1A8LFCL](#) [UPD78F0503AMCA-CAB-G](#) [Z8018008VEG](#) [T1024NXN7MQA](#) [T2080NXE8PTB](#) [T2080NSE8PTB](#)  
[T1024NXE7MQA](#) [CM8063501521600S R19L](#) [T2080NXE8T1B](#) [LS1043AXE7MQB](#) [LS1043ASE7QQB](#) [LS1012AXE7HKA](#)  
[T4240NSN7PQB](#) [MVF30NN152CKU26](#) [FH8067303534005S R3ZM](#) [R9A07G044L24GBG#AC0](#) [HW8076502640002S R38F](#)  
[R7S721030VLFP#AA0](#) [MCIMX6U5DVM10AC](#) [TEN54LSDV23GME](#) [MPC8314VRAGDA](#) [MPC8315VRAGDA](#) [PIC16F1828-I/SS](#)  
[PIC16F690T-I/SS](#) [PIC16F1823-I/SL](#) [PIC18LF14K50-I/SS](#) [LS1021AXN7HNB](#) [AT91SAM9XE256-CU](#) [NS7520B-1-I46](#) [AT91SAM9G35-CU](#)  
[AT91SAM9X25-CU](#) [ST7FLIT35F2DAKTR](#) [Z84C0006PEG](#) [AM1808EZWT4](#) [MPC8347CVRADDB](#) [MCIMX6V7DVN10AB](#)  
[LS1043ASN7PQB](#) [GD32F303RCT6](#) [MPC5121YVY400B](#) [SMS3700HAX4DQE](#) [ADD4200IAA5DOE](#) [ST7PLITE05OBXTR](#) [AT91RM9200-](#)  
[CJ-002](#) [AT91RM9200-QU-002](#)