

P1013

P1013 QorIQ Integrated Processor Hardware Specifications

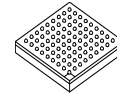

WB-TePBGA II—689
31 mm x 31 mm

The following list provides an overview of the P1013 feature set:

- One high-performance 32-bit e500v2 core that implements the Power Architecture® technology:
- 36-bit physical addressing
 - Double-precision floating-point support
 - 32 KB L1 instruction cache and 32 KB L1 data cache for each core
 - 400-MHz to 1067-MHz clock frequency
- 256 KB L2 cache with ECC. Also configurable as SRAM and stashing memory.
- e500 coherency module (ECM) manages core and intrasystem transactions
- Integrated security engine (SEC)
 - Protocol support includes ARC4, 3DES, AES, RSA/ECC, RNG, single-pass SSL/TLS
 - XOR acceleration
- 64-bit DDR2/DDR3 SDRAM memory controller with ECC support
 - 32/64 bit data interface
 - DDR2/3 supported for data rate up to 800 MT/s
 - Four banks of memory supported, each up to 8 GB
- Programmable interrupt controller (PIC) compliant with OpenPIC standard
- Dual I²C controllers
- Enhanced secure digital host controller (SD/MMC)
- Enhanced Serial peripheral interface (eSPI)
- Enhanced local bus controller (eLBC)
- Display interface unit (DIU)
- I2S interface supported through synchronous serial interface (SSI)
- UART
- Two High-Speed USB controller (USB 2.0)
 - Host and device support
 - Enhanced host controller interface (EHCI)
 - ULPI interface to PHY
- Two enhanced three-speed Ethernet controllers (eTSECs)
 - TCP/IP acceleration, quality of service, and classification capabilities
 - IEEE Std 1588™ support
 - Lossless flow control
 - RGMII, RMII, SGMII
- Two four-channel DMA controllers
- 87 general-purpose I/O signals
- Three PCI Express controllers
- Dual serial ATA (SATA) controllers
- TDM Interface
- Power management
- System performance monitor
- System access port
- IEEE Std 1149.1™- compatible, JTAG boundary scan
- 31 × 31 mm 689-pin WB-TePBGA II (wire bond temperature-enhanced plastic BGA)

Table of Contents

1	Pin assignments and reset states	4	2.15	Display interface unit	63
1.1	Ball layout diagrams	4	2.16	Synchronous Serial Interface (SSI)	66
1.2	Pinout assignments	9	2.17	Programmable Interrupt Controller (PIC) specifications	69
2	Electrical characteristics	23	2.18	I ² C	69
2.1	Overall DC electrical characteristics	23	2.19	GPIO	71
2.2	Power sequencing	26	2.20	TDM	73
2.3	Power down requirements	27	2.21	High-Speed Serial Interfaces (HSSI)	75
2.4	RESET initialization	27	2.22	PCI express	81
2.5	Power-on ramp rate	28	2.23	Serial ATA (SATA)	84
2.6	Power characteristics	28	2.24	JTAG controller	88
2.7	Input clocks	31	3	Thermal	90
2.8	DDR2 and DDR3 SDRAM controller	33	3.1	Thermal characteristics	90
2.9	eSPI	40	4	Package information	92
2.10	DUART	42	4.1	Package parameters for the P1022WB-TePBGA II	92
2.11	Ethernet: Enhanced Three-Speed Ethernet (eTSEC), MII management	43	4.2	Ordering information	93
2.12	USB	55	4.3	Part marking	93
2.13	Enhanced local bus interface	57	5	Product documentation	94
2.14	Enhanced secure digital host controller (eSDHC)	61	6	Revision History	94

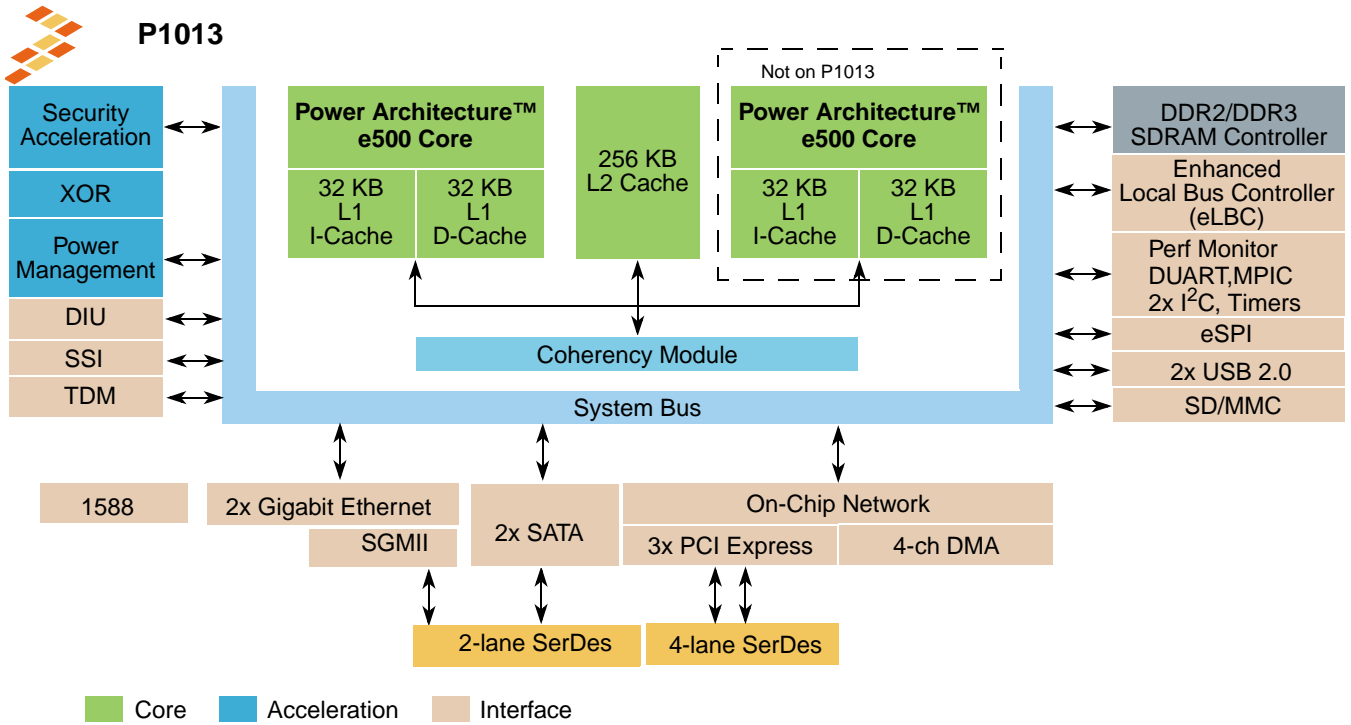

Figure 1. P1013 block diagram

1 Pin assignments and reset states

1.1 Ball layout diagrams

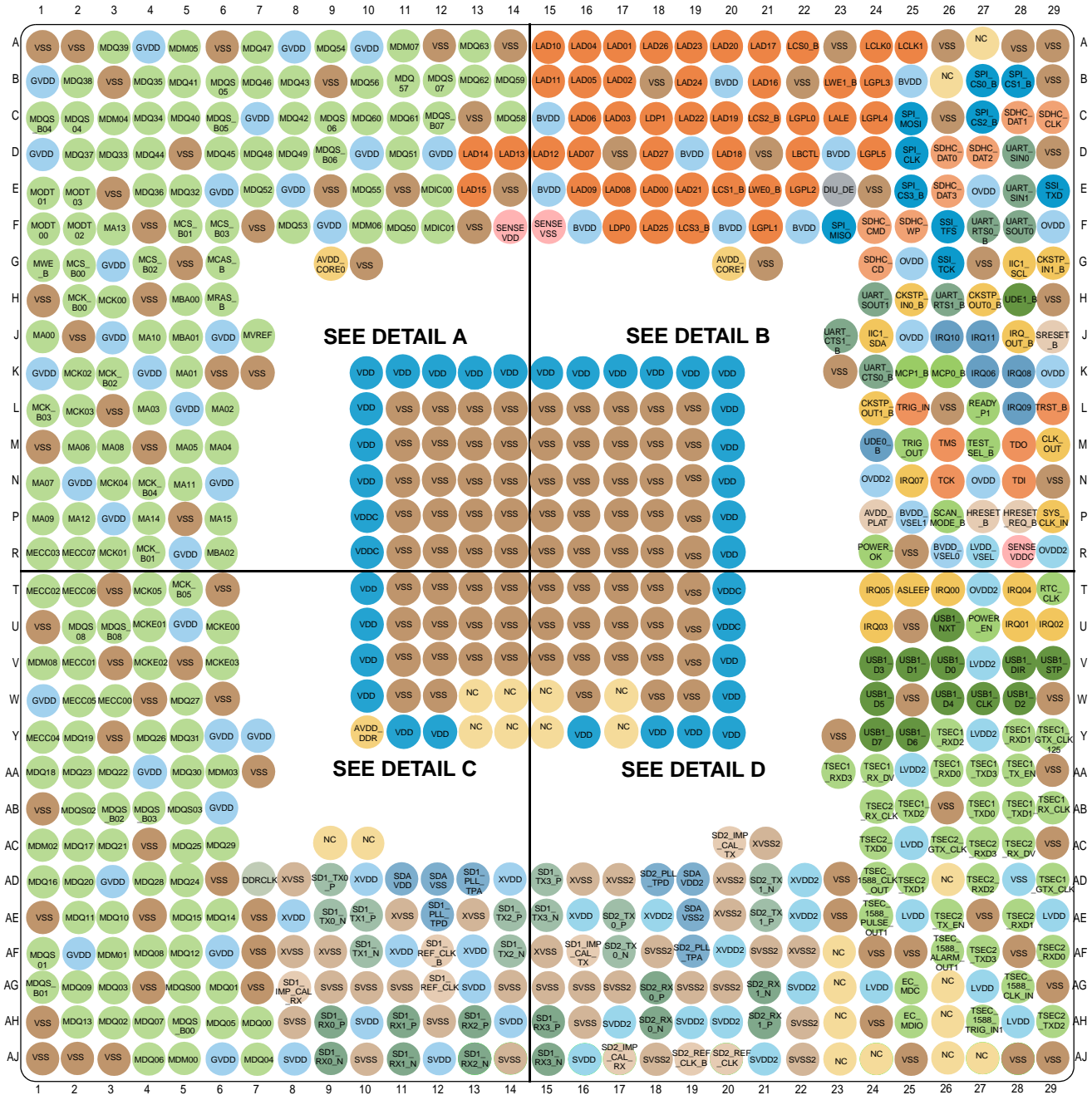

Figure 2. P1013 top view ball map

DETAIL A

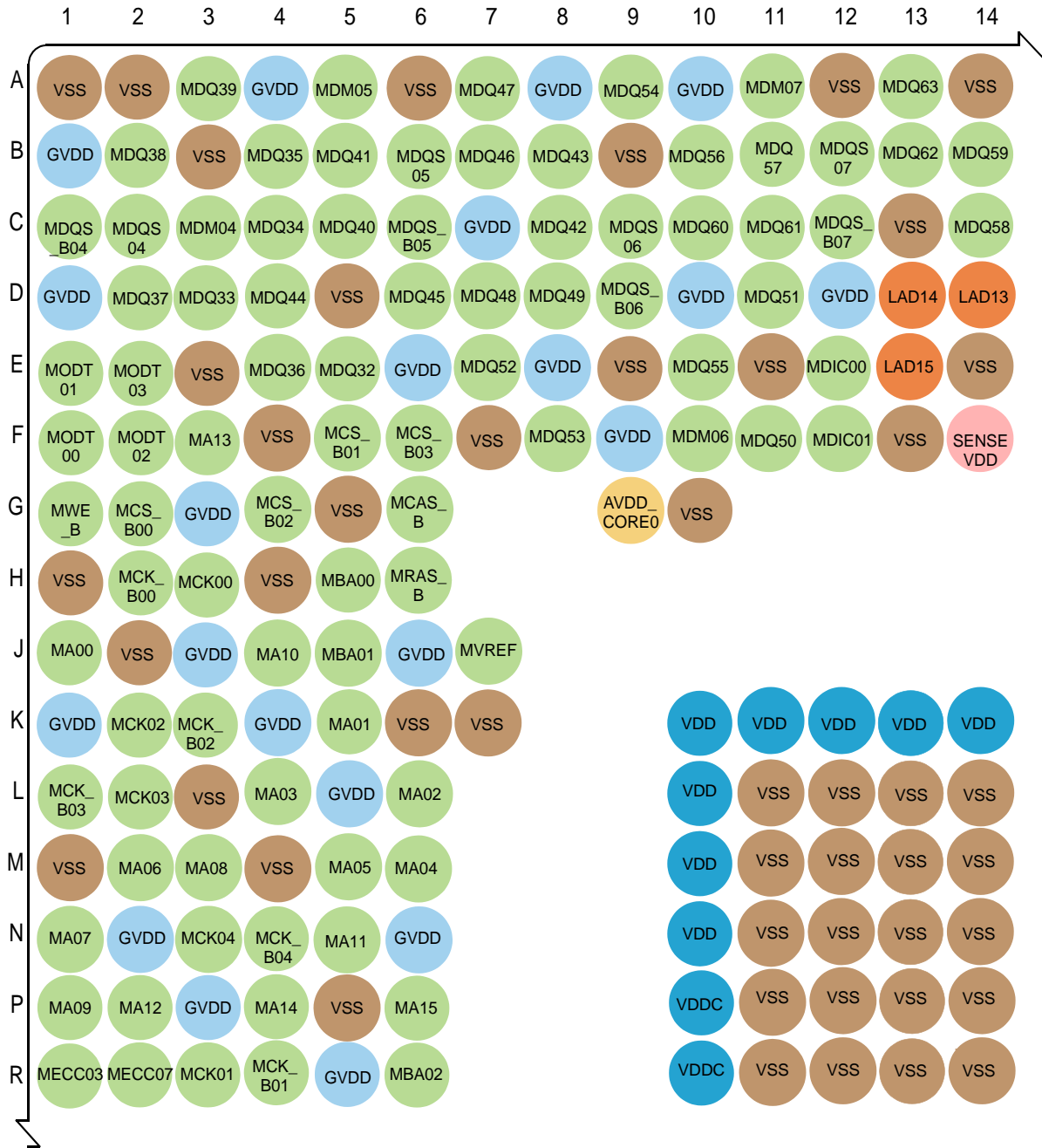

Figure 3. P1013 detail A ball map

DETAIL B

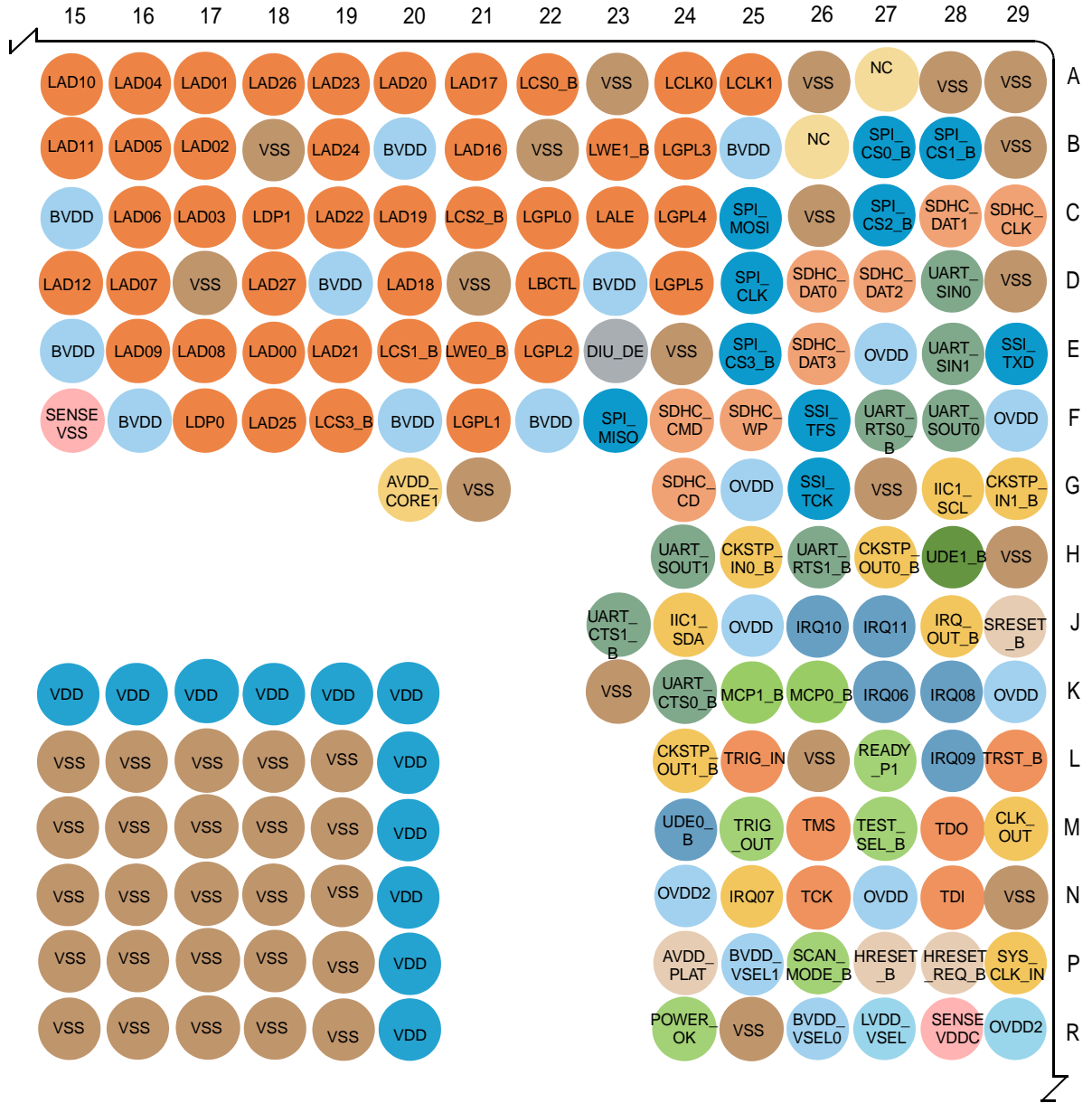

Figure 4. P1013 detail B ball map

DETAIL C

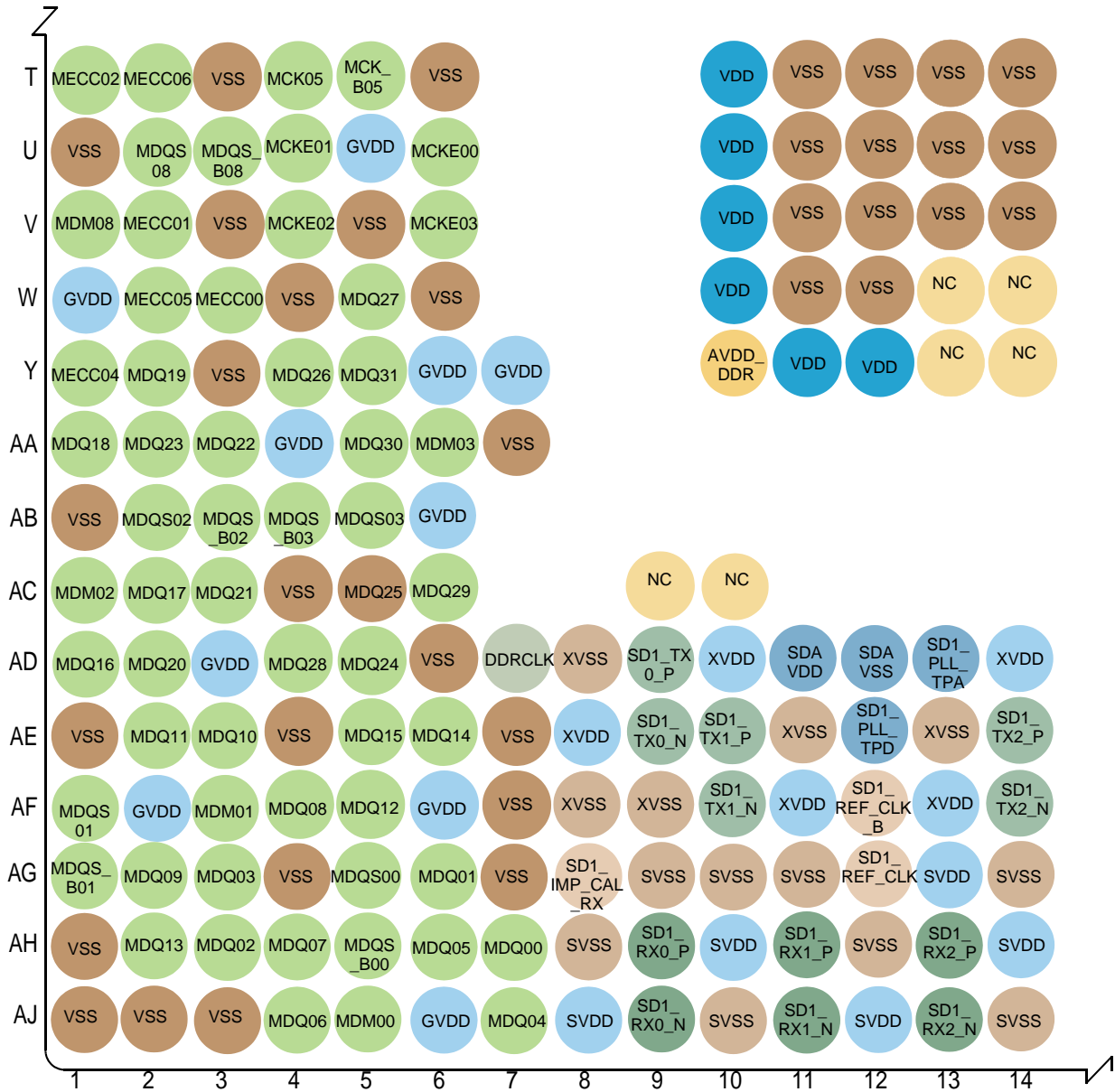

Figure 5. P1013 detail C ball map

DETAIL D



Figure 6. P1013 detail C ball map

1.2 Pinout assignments

Table 1. P1013 pinout listing

Signal	Package pin number	Pin type	Power supply	Note
DDR SDRAM memory interface				
MA00	J1	O	GV_{DD}	—
MA01	K5	O	GV_{DD}	—
MA02	L6	O	GV_{DD}	—
MA03	L4	O	GV_{DD}	—
MA04	M6	O	GV_{DD}	—
MA05	M5	O	GV_{DD}	—
MA06	M2	O	GV_{DD}	—
MA07	N1	O	GV_{DD}	—
MA08	M3	O	GV_{DD}	—
MA09	P1	O	GV_{DD}	—
MA10	J4	O	GV_{DD}	—
MA11	N5	O	GV_{DD}	—
MA12	P2	O	GV_{DD}	—
MA13	F3	O	GV_{DD}	—
MA14	P4	O	GV_{DD}	—
MA15	P6	O	GV_{DD}	—
MDQ00	AH7	I/O	GV_{DD}	—
MDQ01	AG6	I/O	GV_{DD}	—
MDQ02	AH3	I/O	GV_{DD}	—
MDQ03	AG3	I/O	GV_{DD}	—
MDQ04	AJ7	I/O	GV_{DD}	—
MDQ05	AH6	I/O	GV_{DD}	—
MDQ06	AJ4	I/O	GV_{DD}	—
MDQ07	AH4	I/O	GV_{DD}	—
MDQ08	AF4	I/O	GV_{DD}	—
MDQ09	AG2	I/O	GV_{DD}	—
MDQ10	AE3	I/O	GV_{DD}	—
MDQ11	AE2	I/O	GV_{DD}	—
MDQ12	AF5	I/O	GV_{DD}	—
MDQ13	AH2	I/O	GV_{DD}	—
MDQ14	AE6	I/O	GV_{DD}	—
MDQ15	AE5	I/O	GV_{DD}	—

Table 1. P1013 pinout listing (continued)

Signal	Package pin number	Pin type	Power supply	Note
MDQ16	AD1	I/O	GV _{DD}	—
MDQ17	AC2	I/O	GV _{DD}	—
MDQ18	AA1	I/O	GV _{DD}	—
MDQ19	Y2	I/O	GV _{DD}	—
MDQ20	AD2	I/O	GV _{DD}	—
MDQ21	AC3	I/O	GV _{DD}	—
MDQ22	AA3	I/O	GV _{DD}	—
MDQ23	AA2	I/O	GV _{DD}	—
MDQ24	AD5	I/O	GV _{DD}	—
MDQ25	AC5	I/O	GV _{DD}	—
MDQ26	Y4	I/O	GV _{DD}	—
MDQ27	W5	I/O	GV _{DD}	—
MDQ28	AD4	I/O	GV _{DD}	—
MDQ29	AC6	I/O	GV _{DD}	—
MDQ30	AA5	I/O	GV _{DD}	—
MDQ31	Y5	I/O	GV _{DD}	—
MDQ32	E5	I/O	GV _{DD}	—
MDQ33	D3	I/O	GV _{DD}	—
MDQ34	C4	I/O	GV _{DD}	—
MDQ35	B4	I/O	GV _{DD}	—
MDQ36	E4	I/O	GV _{DD}	—
MDQ37	D2	I/O	GV _{DD}	—
MDQ38	B2	I/O	GV _{DD}	—
MDQ39	A3	I/O	GV _{DD}	—
MDQ40	C5	I/O	GV _{DD}	—
MDQ41	B5	I/O	GV _{DD}	—
MDQ42	C8	I/O	GV _{DD}	—
MDQ43	B8	I/O	GV _{DD}	—
MDQ44	D4	I/O	GV _{DD}	—
MDQ45	D6	I/O	GV _{DD}	—
MDQ46	B7	I/O	GV _{DD}	—
MDQ47	A7	I/O	GV _{DD}	—
MDQ48	D7	I/O	GV _{DD}	—
MDQ49	D8	I/O	GV _{DD}	—
MDQ50	F11	I/O	GV _{DD}	—

Table 1. P1013 pinout listing (continued)

Signal	Package pin number	Pin type	Power supply	Note
MDQ51	D11	I/O	GV _{DD}	—
MDQ52	E7	I/O	GV _{DD}	—
MDQ53	F8	I/O	GV _{DD}	—
MDQ54	A9	I/O	GV _{DD}	—
MDQ55	E10	I/O	GV _{DD}	—
MDQ56	B10	I/O	GV _{DD}	—
MDQ57	B11	I/O	GV _{DD}	—
MDQ58	C14	I/O	GV _{DD}	—
MDQ59	B14	I/O	GV _{DD}	—
MDQ60	C10	I/O	GV _{DD}	—
MDQ61	C11	I/O	GV _{DD}	—
MDQ62	B13	I/O	GV _{DD}	—
MDQ63	A13	I/O	GV _{DD}	—
MBA0	H5	O	GV _{DD}	—
MBA1	J5	O	GV _{DD}	—
MBA2	R6	O	GV _{DD}	—
MDQS0	AG5	I/O	GV _{DD}	—
MDQS1	AF1	I/O	GV _{DD}	—
MDQS2	AB2	I/O	GV _{DD}	—
MDQS3	AB5	I/O	GV _{DD}	—
MDQS4	C2	I/O	GV _{DD}	—
MDQS5	B6	I/O	GV _{DD}	—
MDQS6	C9	I/O	GV _{DD}	—
MDQS7	B12	I/O	GV _{DD}	—
MDQS0_B	AH5	I/O	GV _{DD}	—
MDQS1_B	AG1	I/O	GV _{DD}	—
MDQS2_B	AB3	I/O	GV _{DD}	—
MDQS3_B	AB4	I/O	GV _{DD}	—
MDQS4_B	C1	I/O	GV _{DD}	—
MDQS5_B	C6	I/O	GV _{DD}	—
MDQS6_B	D9	I/O	GV _{DD}	—
MDQS7_B	C12	I/O	GV _{DD}	—
MDM0	AJ5	O	GV _{DD}	—
MDM1	AF3	O	GV _{DD}	—
MDM2	AC1	O	GV _{DD}	—

Table 1. P1013 pinout listing (continued)

Signal	Package pin number	Pin type	Power supply	Note
MDM3	AA6	O	GV _{DD}	—
MDM4	C3	O	GV _{DD}	—
MDM5	A5	O	GV _{DD}	—
MDM6	F10	O	GV _{DD}	—
MDM7	A11	O	GV _{DD}	—
MDM8	V1	O	GV _{DD}	—
MCS0_B	G2	O	GV _{DD}	—
MCS1_B	F5	O	GV _{DD}	—
MCS2_B	G4	O	GV _{DD}	—
MCS3_B	F6	O	GV _{DD}	—
MRAS_B	H6	O	GV _{DD}	—
MCAS_B	G6	O	GV _{DD}	—
MWE_B	G1	O	GV _{DD}	—
MCKE0	U6	O	GV _{DD}	17
MCKE1	U4	O	GV _{DD}	17
MCKE2	V4	O	GV _{DD}	17
MCKE3	V6	O	GV _{DD}	17
MCK0	H3	O	GV _{DD}	10
MCK1	R3	O	GV _{DD}	10
MCK2	K2	O	GV _{DD}	10
MCK3	L2	O	GV _{DD}	10
MCK4	N3	O	GV _{DD}	10
MCK5	T4	O	GV _{DD}	10
MCK0_B	H2	O	GV _{DD}	10
MCK1_B	R4	O	GV _{DD}	10
MCK2_B	K3	O	GV _{DD}	10
MCK3_B	L1	O	GV _{DD}	10
MCK4_B	N4	O	GV _{DD}	10
MCK5_B	T5	O	GV _{DD}	10
MODT0	F1	O	GV _{DD}	—
MODT1	E1	O	GV _{DD}	—
MODT2	F2	O	GV _{DD}	—
MODT3	E2	O	GV _{DD}	—
MDIC0	E12	I/O	GV _{DD}	5
MDIC1	F12	I/O	GV _{DD}	5

Table 1. P1013 pinout listing (continued)

Signal	Package pin number	Pin type	Power supply	Note
MECC0	W3	I/O	GV _{DD}	—
MECC1	V2	I/O	GV _{DD}	—
MECC2	T1	I/O	GV _{DD}	—
MECC3	R1	I/O	GV _{DD}	—
MECC4	Y1	I/O	GV _{DD}	—
MECC5	W2	I/O	GV _{DD}	—
MECC6	T2	I/O	GV _{DD}	—
MECC7	R2	I/O	GV _{DD}	—
MDQS8	U2	I/O	GV _{DD}	—
MDQS8_B	U3	I/O	GV _{DD}	—
MVREF	J7	I	GV _{DD}	—
eLBC Controller Interface/DIU				
LAD00	E18	I/O	BV _{DD}	—
LAD01	A17	I/O	BV _{DD}	—
LAD02	B17	I/O	BV _{DD}	—
LAD03	C17	I/O	BV _{DD}	—
LAD04	A16	I/O	BV _{DD}	—
LAD05	B16	I/O	BV _{DD}	—
LAD06	C16	I/O	BV _{DD}	—
LAD07	D16	I/O	BV _{DD}	—
LAD08/DIU_R0	E17	I/O	BV _{DD}	—
LAD09/DIU_R1	E16	I/O	BV _{DD}	21
LAD10/DIU_R2	A15	I/O	BV _{DD}	—
LAD11/DIU_R3	B15	I/O	BV _{DD}	21
LAD12/DIU_R4	D15	I/O	BV _{DD}	14
LAD13/DIU_R5	D14	I/O	BV _{DD}	—
LAD14/DIU_R6	D13	I/O	BV _{DD}	—
LAD15/DIU_R7	E13	I/O	BV _{DD}	21
LDP0/DIU_HSYNC	F17	I/O	BV _{DD}	16, 23
LDP1/DIU_VSYNC	C18	I/O	BV _{DD}	16, 21
LAD16/DIU_G0	B21	I/O	BV _{DD}	26
LAD17/DIU_G1	A21	I/O	BV _{DD}	21
LAD18/DIU_G2	D20	I/O	BV _{DD}	—
LAD19/DIU_G3	C20	I/O	BV _{DD}	—

Table 1. P1013 pinout listing (continued)

Signal	Package pin number	Pin type	Power supply	Note
LAD20/DIU_G4	A20	I/O	BV _{DD}	—
LAD21/DIU_G5	E19	I/O	BV _{DD}	—
LAD22/DIU_G6	C19	I/O	BV _{DD}	—
LAD23/DIU_G7	A19	I/O	BV _{DD}	26
LAD24/DIU_B0/LCS7_B	B19	I/O	BV _{DD}	26
LAD25/DIU_B1/LCS6_B	F18	I/O	BV _{DD}	26
LAD26/DIU_B2/LCS5_B	A18	I/O	BV _{DD}	26
LAD27/DIU_B3/LCS4_B	D18	I/O	BV _{DD}	26
LCS0_B	A22	O	BV _{DD}	16
LCS1_B	E20	O	BV _{DD}	16
LCS2_B/DIU_B5	C21	O	BV _{DD}	16
LCS3_B/DIU_B4/LDP3	F19	I/O	BV _{DD}	16
LWE0_B	E21	O	BV _{DD}	15
LWE1_B/DIU_B6	B23	O	BV _{DD}	—
LBCTL/DIU_B7	D22	O	BV _{DD}	15
LALE	C23	O	BV _{DD}	15
LGPL0	C22	O	BV _{DD}	—
LGPL1	F21	O	BV _{DD}	14
LGPL2	E22	O	BV _{DD}	15
LGPL3	B24	O	BV _{DD}	—
LGPL4	C24	I/O	BV _{DD}	9
LGPL5/DIU_CLKOUT	D24	O	BV _{DD}	—
LCLK0	A24	O	BV _{DD}	—
LCLK1	A25	O	BV _{DD}	—
DIU_DE	E23	O	BV _{DD}	14
USB1 interface				
USB1_NXT/GPIO2_0	U26	I/O	LV _{DD2}	—
USB1_STP/GPIO2_1	V29	I/O	LV _{DD2}	21
USB1_CLK/GPIO2_2	W27	I/O	LV _{DD2}	—
USB1_DIR/GPIO2_3	V28	I/O	LV _{DD2}	—
USB1_D7/GPIO2_4	Y24	I/O	LV _{DD2}	—
USB1_D6/GPIO2_5	Y25	I/O	LV _{DD2}	—
USB1_D5/GPIO2_6	W24	I/O	LV _{DD2}	—
USB1_D4/GPIO2_7	W26	I/O	LV _{DD2}	—

Table 1. P1013 pinout listing (continued)

Signal	Package pin number	Pin type	Power supply	Note
USB1_D3/GPIO2_8	V24	I/O	LV _{DD2}	—
USB1_D2/GPIO2_9	W28	I/O	LV _{DD2}	—
USB1_D1/GPIO2_10	V25	I/O	LV _{DD2}	—
USB1_D0/GPIO2_11	V26	I/O	LV _{DD2}	—
Ethernet 1 interface (RGMII/RMII)				
TSEC1_TX_EN/GPIO2_12	AA28	O	LV _{DD2}	22
TSEC1_TXD0/GPIO2_13	AB27	O	LV _{DD2}	26
TSEC1_TXD1/GPIO2_14	AB28	O	LV _{DD2}	—
TSEC1_TXD2/GPIO2_15	AB25	O	LV _{DD2}	26
TSEC1_TXD3/GPIO2_16	AA27	O	LV _{DD2}	21
TSEC1_GTX_CLK/ TSEC1_TX_CLK/GPIO2_17	AD29	I/O	LV _{DD2}	—
TSEC1_RX_DV/GPIO2_18	AA24	I/O	LV _{DD2}	—
TSEC1_RX_CLK/GPIO2_19	AB29	I/O	LV _{DD2}	—
TSEC1_RXD0/GPIO2_20	AA26	I/O	LV _{DD2}	—
TSEC1_RXD1/GPIO2_21	Y28	I/O	LV _{DD2}	—
TSEC1_RXD2/GPIO2_22	Y26	I/O	LV _{DD2}	—
TSEC1_RXD3/GPIO2_23	AA23	I/O	LV _{DD2}	—
TSEC1_GTX_CLK125/GPIO2 _24	Y29	I/O	LV _{DD2}	—
Ethernet 2 interface (RGMII/RMII)/USB2				
GPIO1_0/TSEC2_TX_EN/ USB2_STP	AE26	I/O	LV _{DD}	22
GPIO1_1/TSEC2_TXD0/USB 2_D4	AC24	I/O	LV _{DD}	—
GPIO1_2/TSEC2_TXD1/USB 2_D5	AD25	I/O	LV _{DD}	—
GPIO1_3/TSEC2_TXD2/USB 2_D6	AH29	I/O	LV _{DD}	—
GPIO1_4/TSEC2_TXD3/USB 2_D7	AF27	I/O	LV _{DD}	—
GPIO1_5/TSEC2_GTX_CLK/ TSEC2_TX_CLK/USB2_CLK	AC26	I/O	LV _{DD}	—
GPIO1_6/TSEC2_RX_DV/ USB2_NXT	AC28	I/O	LV _{DD}	—
GPIO1_7/TSEC2_RX_CLK/ USB2_DIR	AB24	I/O	LV _{DD}	—

Table 1. P1013 pinout listing (continued)

Signal	Package pin number	Pin type	Power supply	Note
GPIO1_8/TSEC2_RXD0/USB2_D0	AF29	I/O	LV _{DD}	—
GPIO1_9/TSEC2_RXD1/USB2_D1	AE28	I/O	LV _{DD}	—
GPIO1_10/TSEC2_RXD2/USB2_D2	AD27	I/O	LV _{DD}	—
GPIO1_11/TSEC2_RXD3/USB2_D3	AC27	I/O	LV _{DD}	—
Ethernet MI				
EC_MDC	AG25	O	LV _{DD}	—
EC_MDIO	AH25	I/O	LV _{DD}	—
1588				
TSEC_1588_CLK_IN/USB1_PWRFAULT/GPIO1_12	AG28	I/O	LV _{DD}	—
TSEC_1588_TRIG_IN1/TSEC2_GTX_CLK125/USB2_PWRFAULT/GPIO1_13	AH27	I/O	LV _{DD}	—
TSEC_1588_ALARM_OUT1/GPIO1_14	AF26	O	LV _{DD}	—
TSEC_1588_CLK_OUT/GPIO1_15	AD24	O	LV _{DD}	21
TSEC_1588_PULSE_OUT1/GPIO1_16	AE24	O	LV _{DD}	23
eSPI/eSDHC				
SPI_MOSI/LWE2_B/GPIO1_17	C25	I/O	BV _{DD}	1
SPI_MISO/LWE3_B/GPIO1_18	F23	I/O	BV _{DD}	1
SPI_CLK/LDP2/GPIO1_19	D25	I/O	BV _{DD}	1
SPI_CS0_B/SDHC_DAT4/LAD28/GPIO1_20	B27	I/O	BV _{DD}	1
SPI_CS1_B/SDHC_DAT5/LAD29/GPIO1_21	B28	I/O	BV _{DD}	1
SPI_CS2_B/SDHC_DAT6/LAD30/GPIO1_22	C27	I/O	BV _{DD}	1
SPI_CS3_B/SDHC_DAT7/LAD31/GPIO1_23	E25	I/O	BV _{DD}	1
SDHC_CMD/GPIO1_24	F24	I/O	OV _{DD}	—
SDHC_DAT0/GPIO1_25	D26	I/O	OV _{DD}	—
SDHC_DAT1	C28	I/O	OV _{DD}	—

Table 1. P1013 pinout listing (continued)

Signal	Package pin number	Pin type	Power supply	Note
SDHC_DAT2	D27	I/O	OV _{DD}	—
SDHC_DAT3/GPIO1_26	E26	I/O	OV _{DD}	27
SDHC_CLK/GPIO1_27	C29	I/O	OV _{DD}	—
SDHC_CD/GPIO1_28	G24	I/O	OV _{DD}	—
SDHC_WP/GPIO1_29	F25	I/O	OV _{DD}	—
DUART/I²C/SSI				
UART_SOUT0/DMA_DACK0_B/ GPIO1_30	F28	O	OV _{DD}	—
UART_SIN0/DMA_DREQ0_B/ GPIO1_31	D28	I/O	OV _{DD}	—
UART_CTS0_B/SSI_RCK/ TDM_RCLK/GPIO3_0	K24	I/O	OV _{DD}	—
UART_RTS0_B/DMA_DDON E0_B/ GPIO3_1	F27	O	OV _{DD}	23
IIC1_SDA/SSI_RXD/TDM_RX D	J24	I/O	OV _{DD}	13, 20
IIC1_SCL/SSI_RFS/TDM_RF S	G28	I/O	OV _{DD}	13, 20
UART_SOUT1/GPIO3_2	H24	O	OV _{DD}	15
UART_SIN1/GPIO3_3	E28	I/O	OV _{DD}	—
UART_CTS1_B/IIC2_SCL/GP IO3_4	J23	I/O	OV _{DD}	13, 20
UART_RTS1_B/IIC2_SDA/GP IO3_5	H26	I/O	OV _{DD}	13, 20
SSI_TCK/DMA_DACK1_B/ TDM_TCK/GPIO3_6	G26	I/O	OV _{DD}	—
SSI_TFS/DMA_DDONE1_B/ TDM_TFS/GPIO3_7	F26	I/O	OV _{DD}	—
SSI_TXD/DMA_DREQ1_B/ TDM_TXD/GPIO3_8	E29	I/O	OV _{DD}	—
Reset/System control				
HRESET_B	P27	I	OV _{DD2}	—
HRESET_REQ_B	P28	O	OV _{DD2}	21
SRESET_B	J29	I	OV _{DD}	—
CKSTP_IN0_B	H25	I	OV _{DD}	11
CKSTP_IN1_B	G29	I	OV _{DD}	11
CKSTP_OUT0_B	H27	O	OV _{DD}	11,13

Table 1. P1013 pinout listing (continued)

Signal	Package pin number	Pin type	Power supply	Note
CKSTP_OUT1_B	L24	O	OV _{DD}	11,13
Clocks				
SYS_CLK_IN	P29	I	OV _{DD2}	7
RTC_CLK	T29	I	OV _{DD2}	—
DDRCLK	AD7	I	OV _{DD2}	24
Interrupts				
IRQ00/DMA_DREQ2_B/GPIO2_25	T26	I/O	OV _{DD2}	—
IRQ01/DMA_DACK2_B/GPIO2_26	U28	I/O	OV _{DD2}	—
IRQ02/DMA_DDONE2_B/GPIO2_27	U29	I/O	OV _{DD2}	—
IRQ03/DMA_DREQ3_B/GPIO2_28	U24	I/O	OV _{DD2}	—
IRQ04/DMA_DACK3_B/GPIO2_29	T28	I/O	OV _{DD2}	—
IRQ05/DMA_DDONE3_B/GPIO2_30	T24	I/O	OV _{DD2}	—
IRQ06/MSRCID0/LB_MSRCID0/GPIO2_31	K27	I/O	OV _{DD}	—
IRQ07/MSRCID1/LB_MSRCID1/GPIO3_9	N25	I/O	OV _{DD}	—
IRQ08/MSRCID2/LB_MSRCID2/GPIO3_10	K28	I/O	OV _{DD}	—
IRQ09/MSRCID3/LB_MSRCID3/GPIO3_11	L28	I/O	OV _{DD}	—
IRQ10/MSRCID4/LB_MSRCID4/GPIO3_12	J26	I/O	OV _{DD}	—
IRQ11/MDVAL/LB_MDVAL/GPIO3_13	J27	I/O	OV _{DD}	—
MCP0_B/GPIO3_14	K26	I/O	OV _{DD}	—
MCP1_B/GPIO3_15	K25	I/O	OV _{DD}	—
UDE0_B/GPIO3_16	M24	I/O	OV _{DD}	—
UDE1_B/GPIO3_17	H28	I/O	OV _{DD}	—
IRQ_OUT_B/GPIO3_18	J28	O	OV _{DD}	12, 13, 21

Table 1. P1013 pinout listing (continued)

Signal	Package pin number	Pin type	Power supply	Note
I/O VSEL				
LV _{DD} _VSEL	R27	I	OV _{DD2}	25
BV _{DD} _VSEL0	R26	I	OV _{DD2}	25
BV _{DD} _VSEL1	P25	I	OV _{DD2}	25
JTAG				
TCK	N26	I	OV _{DD2}	—
TDI	N28	I	OV _{DD2}	18
TDO	M28	O	OV _{DD2}	17
TMS	M26	I	OV _{DD2}	18
TRST_B	L29	I	OV _{DD2}	18
Misc debug/power management/DFT				
SCAN_MODE_B	P26	I	OV _{DD2}	28
TEST_SEL	M27	I	OV _{DD2}	2
ASLEEP	T25	O	OV _{DD2}	26
POWER_EN	U27	O	OV _{DD2}	—
POWER_OK/GPIO3_19	R24	I/O	OV _{DD2}	—
TRIG_IN/GPIO3_20	L25	I/O	OV _{DD}	—
TRIG_OUT/READY_P0/GPIO3_21	M25	O	OV _{DD2}	—
READY_P1/GPIO3_22	L27	O	OV _{DD2}	15
CLK_OUT	M29	O	OV _{DD}	—
SerDes 1(x4)				
SD1_TX0_P	AD9	O	XV _{DD}	—
SD1_TX1_P	AE10	O	XV _{DD}	—
SD1_TX2_P	AE14	O	XV _{DD}	—
SD1_TX3_P	AD15	O	XV _{DD}	—
SD1_TX0_N	AE9	O	XV _{DD}	—
SD1_TX1_N	AF10	O	XV _{DD}	—
SD1_TX2_N	AF14	O	XV _{DD}	—
SD1_TX3_N	AE15	O	XV _{DD}	—
SD1_RX0_P	AH9	I	SV _{DD}	—
SD1_RX1_P	AH11	I	SV _{DD}	—
SD1_RX2_P	AH13	I	SV _{DD}	—
SD1_RX3_P	AH15	I	SV _{DD}	—

Table 1. P1013 pinout listing (continued)

Signal	Package pin number	Pin type	Power supply	Note
SD1_RX0_N	AJ9	I	SV _{DD}	—
SD1_RX1_N	AJ11	I	SV _{DD}	—
SD1_RX2_N	AJ13	I	SV _{DD}	—
SD1_RX3_N	AJ15	I	SV _{DD}	—
SD1_REF_CLK	AG12	I	XV _{DD}	—
SD1_REF_CLK_B	AF12	I	XV _{DD}	—
SD1_PLL_TPD	AE12	O	XV _{DD}	—
SD1_IMP_CAL_TX	AF16	I	XV _{DD}	3
SD1_IMP_CAL_RX	AG8	I	XV _{DD}	4
SD1_PLL_TPA	AD13	O	XV _{DD}	—
SerDes 2(x2)				
SD2_TX0_P	AE17	O	XV _{DD2}	—
SD2_TX1_P	AE21	O	XV _{DD2}	—
SD2_TX0_N	AF17	O	XV _{DD2}	—
SD2_TX1_N	AD21	O	XV _{DD2}	—
SD2_RX0_P	AG18	I	SV _{DD2}	—
SD2_RX1_P	AH21	I	SV _{DD2}	—
SD2_RX0_N	AH18	I	SV _{DD2}	—
SD2_RX1_N	AG21	I	SV _{DD2}	—
SD2_REF_CLK	AJ20	I	XV _{DD2}	—
SD2_REF_CLK_B	AJ19	I	XV _{DD2}	—
SD2_PLL_TPD	AD18	O	XV _{DD2}	—
SD2_IMP_CAL_TX	AC20	I	XV _{DD2}	3
SD2_IMP_CAL_RX	AJ17	I	XV _{DD2}	4
SD2_PLL_TPA	AF19	O	XV _{DD2}	—
Voltage sense/process				
SENSEVDD	F14	I/O	—	6
SENSEVDDC	R28	I/O	—	6
SENSEVSS	F15	I/O	—	6
Power				
AV _{DD} _CORE1	G20	I	—	19
AV _{DD} _DDR	Y10	I	—	19
AV _{DD} _PLAT	P24	I	—	19

Table 1. P1013 pinout listing (continued)

Signal	Package pin number	Pin type	Power supply	Note
GV _{DD}	A10, A4, A8, AA4, AB6, AD3, AF2, AF6, AJ6, B1, C7, D1, D10, D12, E6, E8, F9, G3, J3, J6, K1, K4, L5, N2, N6, P3, R5, U5, W1, Y6, Y7	I	—	—
BV _{DD}	B20, B25, C15, D19, D23, E15, F16, F20, F22	I	—	—
OV _{DD}	E27, F29, G25, J25, K29, N27	I	—	8
OV _{DD2}	N24, R29, T27	I	—	8
LV _{DD}	AC25, AE25, AE29, AG24, AG27, AH28	I	—	8
LV _{DD2}	AA25, V27, Y27	I	—	8
SV _{DD}	AG13, AH10, AH14, AJ12, AJ16, AJ8	I	—	—
SV _{DD2}	AG22, AH17, AH19, AH20, AJ21	I	—	—
SDAV _{DD}	AD11	I	—	—
SDAV _{DD2}	AD19	I	—	—
XV _{DD}	AD10, AD14, AE16, AE8, AF11, AF13	I	—	—
XV _{DD2}	AD22, AE18, AE22, AF20	I	—	—
VDDC	P10, R10, T20, U20	I	—	8
VDD	K10, K11, K12, K13, K14, K15, K16, K17, K18, K19, K20, L10, L20, M10, M20, N10, N20, P20, R20, T10, U10, V10, V20, W10, W20, Y11, Y12, Y16, Y18, Y19, Y20, G9	I	—	8
Ground				
VSS	A1, A2, A6, A12, A14, A23, A26, A28, A29, AA29, AA7, AB1, AB26, AC4, AC29, AD6, AD23, AE1, AE4, AE23, AE27, AF7, AF24, AF25, AF28, AG4, AG7, AG29, AH1, AH24, AJ1, AJ2, AJ3, AJ25, AJ28, AJ29, B3, B9, B18, B22, B29, C13, C26, D5, D17, D21, D29, E3, E9, E11, E14, E24, F4, F7, F13, G5, G10, G21, G27, H1, H4, H29, J2, K6, K7, K23, L3, L11, L12, L13, L14, L15, L16, L17, L18, L19, L26, M1, M4, M11, M12, M13, M14, M15, M16, M17, M18, M19, N11, N12, N13, N14, N15, N16, N17, N18, N19, N29, P5, P11, P12, P13, P14, P15, P16, P17, P18, P19, R11, R12, R13, R14, R15, R16, R17, R18, R19, R25, T3, T6, T11, T12, T13, T14, T15, T16, T17, T18, T19, U1, U11, U12, U13, U14, U15, U16, U17, U18, U19, U25, V3, V5, V11, V12, V13, V14, V15, V16, V17, V18, V19, W4, W6, W11, W12, W16, W18, W19, W25, W29, Y3, Y23, AE7, AD28	I	—	—
SDAVSS	AD12	I	—	—
SDAVSS2	AE19	I	—	—
XV _{SS}	AD16, AD8, AE11, AE13, AF15, AF8, AF9	I	—	—
XV _{SS2}	AC21, AD17, AD20, AE20, AF22	I	—	—

Table 1. P1013 pinout listing (continued)

Signal	Package pin number	Pin type	Power supply	Note
SVSS	AG9, AG10, AG11, AG14, AG15, AG16, AH8, AH12, AH16, AJ10, AJ14,	I	—	—
SVSS2	AF18, AF21, AG17, AG19, AG20, AH22, AJ18, AJ22	I	—	—
Not connected				
NC	AC10, AC9, AF23, AG23, AG26, AH23, AH26, AJ23, AJ24, AJ26, AJ27, W13, W14, W15, W17, Y13, Y14, Y15, Y17, AD26, B26, A27	NC	—	—

Note:

- For eSDHC (8-bit), BV_{DD} must be 3.3V
- This pin must be pulled down
- Connect with 100ohm ($\pm 1\%$) to GND
- Connect with 200ohm ($\pm 1\%$) to GND
- In DDR2 mode, connect MDIC[0] to GND and MDIC[1] to GVDD through 18.2 Ω (full strength mode) or 36.4 Ω (half strength mode) precision 1% resistors. In DDR3 mode these resistors must be 20x (full strength mode) or 40x (half strength mode). These pins are used for automatic hardware calibration of DDR I/Os.
- These pins can be left unconnected if they are not used.
- Also referred to as SYSCLK in this document. This is the main system clock of the device.
- Switchable supplies must be derived from their continuous counterparts as shown in Section "External Power Supply Requirements" in the *P1022 QorIQ Integrated Processor Reference Manual*.
- For systems which boot from Local Bus (GPCM)-controller NOR flash or (FCM)-controlled NAND flash, a pull up on LGPL4 is required.
- Disable the clocks that are not used via the DDRCLKDR register. By default, all clocks are enabled, but all clock signals might not be used in an application. DDRCLKDR is in Section "Global Utilities" in the *P1022 QorIQ Integrated Processor Reference Manual*.
- It is recommended that a weak pull-up resistor (2-10k Ω) be placed on these pins to OV_{DD} .
- If this pin is configured as IRQ_OUT, it is recommended that a weak pull-up resistor (2-10k Ω) be placed on this pin to OV_{DD} .
- These pins CKSTP_OUT0_B, CKSTP_OUT1_B, IRQ_OUT, IIC1_SDA, IIC1_SCL, IIC2_SDA, IIC2_SCL are open drain signals. Further GPIO pins may be programmed to operate as open-drain signals.
- The value of DIU_DE, LAD[12] and LGPL[1] during reset sets the CCB clock to SYSCLK PLL ratio. These pins require 4.7k Ω pull-up or pull-down resistors. See *P1022 QorIQ Integrated Processor Reference Manual* for clock ratio settings.
- The value of LBCTL, LALE, LGPL[02], LWE[00], UART_SOUT[01], and READY_P1, at reset set the e500 core clock to CCB Clock PLL ratio. These pins require 4.7k Ω pull-up or pull-down resistors. See *P1022 QorIQ Integrated Processor Reference Manual* for clock ratio settings.
- If these pins are configured for local bus controller use, it is recommend that a weak pull-up resistor (2-10k Ω) be placed on these pins to BVDD, to ensure that there is no random chip select assertion due to possible noise.
- These outputs are actively driven during reset rather than being tristated during reset.
- These JTAG pins have weak internal pull-ups that are always enabled.
- Independent supplies derived from board V_{DD} .
- When used as I²C, it is recommended that an appropriate pull-up resistor be placed on these pins to OV_{DD} .
- These pins must NOT be pulled down by a resistor or the component they are connected to during power-on reset. When pulled low during POR, the device behavior may be undefined.
- When eTSEC1 and eTSEC2 are used as parallel interfaces, pins TSEC1_TX_EN and TSEC2_TX_EN require an external 4.7k Ω pull-down resistor to prevent PHY from seeing a valid Transmit Enable before it is actively driven.

Table 1. P1013 pinout listing (continued)

Signal	Package pin number	Pin type	Power supply	Note
--------	--------------------	----------	--------------	------

23. The value of UART_RTS0, 1588_PULSE_OUT1 and LDP0, at reset set the DDR controller Clock PLL ratio. These pins require 4.7k Ω pull-up or pull-down resistors. See *P1022 QorIQ Integrated Processor Reference Manual* for clock ratio settings.
24. DDRCLK input is only required when the P1013 DDR controller is running in asynchronous mode. When the DDR controller is configured to run in synchronous mode via reset configuration setting `cfg_ddr_pll[0:2]= 111`, the DDRCLK input is not required. It is recommended to tie it off to GND when DDR controller is running in synchronous mode. See the *P1022 QorIQ Integrated Processor Reference Manual* for more details.
25. Incorrect settings can lead to irreversible device damage.
26. These pins are all reset configuration pins. See the Chapter “Reset Configuration” in the *P1022 QorIQ Integrated Processor Reference Manual* for details on what configuration is done by these pins. These pins require a 4.7k Ω pull-up or pull-down resistor.
27. 100k Ω pull-down needed if SDHC_DAT3 signal used as CD pin for SD cards. This pull down is not needed for MMC cards.
28. This pin requires a 1 k Ω pull-up to OV_{DD2}

2 Electrical characteristics

This section provides the AC and DC electrical specifications for the P1013 device. The device is currently targeted to these specifications. Some of these specifications are independent of the I/O cell, but are included for a more complete reference. These are not purely I/O buffer design specifications.

2.1 Overall DC electrical characteristics

This section covers the ratings, conditions, and other characteristics.

2.1.1 Absolute maximum ratings

This table provides the absolute maximum ratings.

Table 2. Absolute maximum ratings¹

Characteristic		Core Frequency	Symbol	Max value	Unit	Note
Supply voltage for DDR, eTSEC, ECM, and COP		1067MHz or less	V_{DDC}	-0.3 to 1.05	V	—
		1200MHz		-0.3 to 1.1		
Cores and platform supply voltage (except the ones mentioned above)		1067MHz or less	V_{DD}	-0.3 to 1.05	V	—
		1200MHz		-0.3 to 1.1		
PLL supply voltages		1067MHz or less	AV_{DD_CORE0} , AV_{DD_CORE1} , AV_{DD_DDR} , AV_{DD_PLAT}	-0.3 to 1.05	V	2
		1200MHz		-0.3 to 1.1		
SerDes transceivers	Main power supply for internal circuitry of SerDes and pad power supply for SerDes receiver	1067MHz or less	SV_{DD} , SV_{DD2}	-0.3 to 1.05	V	—
		1200MHz		-0.3 to 1.1		
	Pad power supply for Serdes transmitter	1067MHz or less	XV_{DD} , XV_{DD2}	-0.3 to 1.05	V	—
		1200MHz		-0.3 to 1.1		
	PLL power supply	1067MHz or less	$SDAV_{DD}$, $SDAV_{DD2}$	-0.3 to 1.05		—
		1200MHz		-0.3 to 1.1		
DDR2/3 DRAM I/O voltage			GV_{DD}	-0.3 to 1.98 -0.3 to 1.65	V	—
Three-speed ethernet I/O, MII management voltage, USB			LV_{DD} , LV_{DD2}	-0.3 to 3.63 -0.3 to 2.75	V	—
DUART, I ² C, SSI, eSDHC, system control and power management, and JTAG I/O voltage			OV_{DD} , OV_{DD2}	-0.3 to 3.63	V	—
eSPI, eSDHC, DIU, and eLBC I/O voltage			BV_{DD}	-0.3 to 3.63 -0.3 to 2.75 -0.3 to 1.98	V	—

Table 2. Absolute maximum ratings¹ (continued)

Characteristic		Core Frequency	Symbol	Max value	Unit	Note
Input voltage	DDR2/DDR3 DRAM signals		MV_{IN}	-0.3 to ($GV_{DD} + 0.3$)	V	3, 6
	DDR2/DDR3 DRAM reference		MV_{REF}	-0.3 to ($GV_{DD}/2 + 0.3$)	V	6
	USB and three-speed ethernet signals		LV_{IN}	-0.3 to ($LV_{DD} + 0.3$)	V	5, 6
	eSPI, eSDHC, DIU, and eLBC signals		BV_{IN}	-0.3 to ($BV_{DD} + 0.3$)	—	7
	DUART, SYSCCLK, system control and power management, I ² C, and JTAG signals		OV_{IN}	-0.3 to ($OV_{DD} + 0.3$)	V	4, 6
	SerDes signals		SV_{IN}	-0.3 to ($SV_{DD} + 0.3$)		8
Storage temperature range			T_{STG}	-55 to 150	°C	—

Note:

1. Functional operating conditions are given in Table 3. Absolute maximum ratings are stress ratings only, and functional operation at the maximums is not guaranteed. Stresses beyond those listed may affect device reliability or cause permanent damage to the device.
2. AV_{DD_CORE0} , AV_{DD_CORE1} , AV_{DD_PLAT} and AV_{DD_DDR} are measured at the input to the filter (as shown in AN4343) and not at the pin of the device.
3. **Caution:** MV_{IN} must not exceed GV_{DD} by more than 0.3 V. This limit may be exceeded for a maximum of 20 ms during power-on reset and power-down sequences.
4. **Caution:** OV_{IN} must not exceed OV_{DD} by more than 0.3 V. This limit may be exceeded for a maximum of 20 ms during power-on reset and power-down sequences.
5. **Caution:** LV_{IN} must not exceed LV_{DD} by more than 0.3 V. This limit may be exceeded for a maximum of 20 ms during power-on reset and power-down sequences.
6. (M,L,O) V_{IN} and MV_{REF} may overshoot/undershoot to a voltage and for a maximum duration as shown in Figure 7.
7. **Caution:** BV_{IN} must not exceed BV_{DD} by more than 0.3 V. This limit may be exceeded for a maximum of 20 ms during power-on reset and power-down sequences.
8. **Caution:** SV_{IN} must not exceed XV_{DD} by more than 0.3 V. This limit may be exceeded for a maximum of 20 ms during power-on reset and power-down sequences.

2.1.2 Recommended operating conditions

This table provides the recommended operating conditions for this device. Note that the values in this table are the recommended and tested operating conditions. Proper device operation outside these conditions is not guaranteed.

Table 3. Recommended operating conditions

Characteristic	Core Frequency	Symbol	Recommended value	Unit	Note
Supply voltage for DDR, eTSEC, ECM and COP	1067MHz or less	V_{DDC}	1.0 ± 50 mV	V	
	1200MHz		1.05 ± 50 mV		
Cores and Platform supply voltage	1067MHz or less	V_{DD}	1.0 ± 50 mV	V	
	1200MHz		1.05 ± 50 mV		

Electrical characteristics

Table 3. Recommended operating conditions (continued)

Characteristic		Core Frequency	Symbol	Recommended value	Unit	Note	
PLL supply voltages		1067MHz or less	AV _{DD_CORE0}	1.0 ± 50 mV	V	—	
		1200MHz	AV _{DD_CORE1} AV _{DD_DDR} AV _{DD_PLAT}	1.05 ± 50 mV			
SerDes transceivers	Main power supply for internal circuitry of SerDes and pad power supply for SerDes receiver	1067MHz or less	SV _{DD}	1.0 ± 50 mV	V	—	
		1200MHz	SV _{DD2}	1.05 ± 50 mV			
	Pad power supply for Serdes transmitter	1067MHz or less	XV _{DD}	1.0 ± 50 mV	V	—	
		1200MHz	XV _{DD2}	1.05 ± 50 mV			
	PLL power supply	1067MHz or less	SDAV _{DD}	1.0 ± 50 mV	—	—	
		1200MHz	SDAV _{DD2}	1.05 ± 50 mV			
	DDR2/3 DRAM I/O voltage			GV _{DD}	1.8 V ± 100 mV 1.5 V ± 75 mV	V	1
	Three-speed ethernet I/O, MII management voltage, USB			LV _{DD} LV _{DD2}	3.3 V ± 165 mV 2.5 V ± 125 mV	—	1
DUART, I ² C, SSI, eSDHC, system control and power management and JTAG I/O voltage			OV _{DD} OV _{DD2}	3.3 V ± 165 mV	V	1	
eSPI, eSDHC, DIU, and eLBC I/O voltage			BV _{DD}	3.3 V ± 165 mV 2.5 V ± 125 mV 1.8 V ± 90 mV	V	1	
Input voltage	DDR2/DDR3 DRAM signals		MV _{IN}	GND to GV _{DD}	V	—	
	DDR3 DRAM reference		MV _{REF}	GV _{DD} /2 ± 2%	V	—	
	DDR2 DRAM reference		MV _{REF}	GV _{DD} /2 ± 2%	V	—	
	Three-speed ethernet signals and USB		LV _{IN}	GND to LV _{DD}	V	—	
	eSPI, eSDHC, DIU, and eLBC signals		BV _{IN}	GND to BV _{DD}	V	—	
	DUART, SYSCLK, system control and power management, I ² C, and JTAG signals		OV _{IN}	GND to OV _{DD}	V	—	
	SerDes signals		SV _{IN}	GND to SV _{DD}	V	—	
Operational temperature range			T _A /T _J	0 to 105 Commercial -40 to 125 Industrial	°C	2	

Note:

1. **Caution:** Until V_{DD} reaches its recommended operating voltage, if L/B/G/OV_{DD} exceeds V_{DD} extra current may be drawn by the device.
2. Min temp is specified with T_A; Max temp is specified with T_J.
3. All I/O pins must be interfaced with peripheral devices operating at the same voltage level.
4. In deep sleep power saving mode all switchable power supplies must be switched off to prevent damage to the device.

This figure shows the undershoot and overshoot voltages at the interfaces of the device.

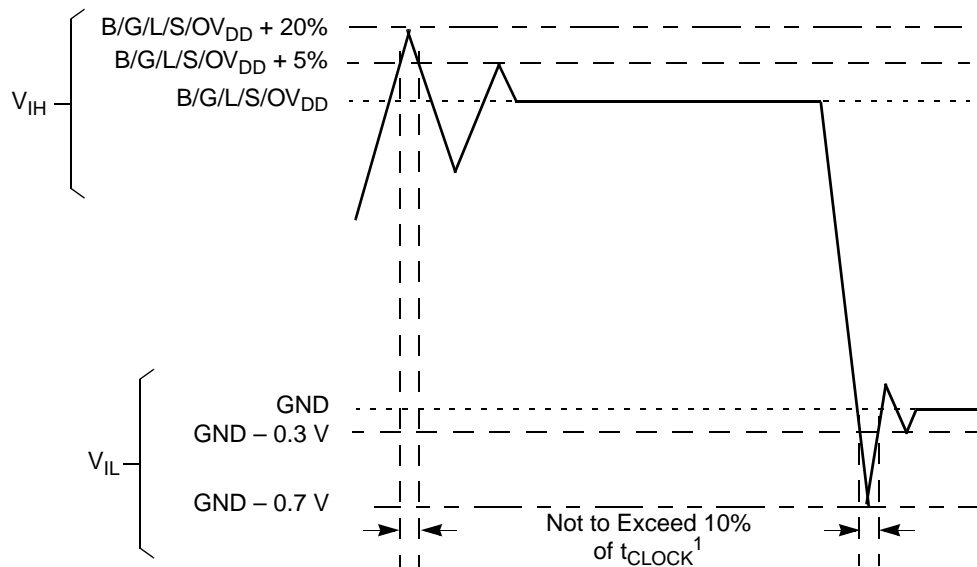

Note:

- t_{CLOCK} refers to the clock period associated with the respective interface:
 For I²C and JTAG, t_{CLOCK} references SYSCLK.
 For DDR, t_{CLOCK} references MCLK.
 For eTSEC, t_{CLOCK} references EC_GTX_CLK125.
 For eLBC, t_{CLOCK} references LCLK.
 For Serdes SV_{DD}, t_{CLOCK} references SD_REF_CLK.

Figure 7. Overshoot/Undershoot voltage for BV_{DD}/GV_{DD}/LV_{DD}/SV_{DD}/OV_{DD}

The core voltage must always be provided at nominal rated VDD (see Table 3 for actual recommended core voltage). Voltage to the processor interface I/Os are provided through separate sets of supply pins and must be provided at the voltages shown in Table 3. The input voltage threshold scales with respect to the associated I/O supply voltage. OV_{DD}, BV_{DD} and LV_{DD} based receivers are simple CMOS I/O circuits and satisfy appropriate LVCMOS type specifications. The DDR2/3 SDRAM interface uses a differential receiver referenced the externally supplied MV_{REF} signal (nominally set to GV_{DD}/2).

2.1.3 Output driver characteristics

This table provides information on the characteristics of the output driver strengths. The values are preliminary estimates.

Table 4. Output drive capability

Driver Type	Output impedance (Ω)	Supply voltage	Note
eSPI, eSDHC, DIU, and eLBC interface	45 45 45	BV _{DD} = 3.3 V BV _{DD} = 2.5 V BV _{DD} = 1.8 V	2
DDR2/3 signal (Programmable)	16 32 (half strength mode)	GV _{DD} = 1.8 V DDR2 GV _{DD} = 1.5 V DDR3	1
USB and eTSEC signals	45	LV _{DD} = 2.5/3.3 V LV _{DD2} = 2.5/3.3 V	2
DUART, I ² C, SSI, eSDHC, system control, JTAG	45	OV _{DD} = 3.3 V OV _{DD2} = 3.3 V	2

Table 4. Output drive capability (continued)

Driver Type	Output impedance (Ω)	Supply voltage	Note
-------------	-------------------------------	----------------	------

Note:

1. The drive strength of the DDR2/3 interface in half-strength mode is at $T_j = 105^\circ\text{C}$ and at GV_{DD} (min)
2. For GPIOs multiplexed with pins on these power supplies the drive capabilities are similar to those of the primary functions of the pins.

2.2 Power sequencing

The device requires its power rails to be applied in a specific sequence in order to ensure proper device operation. These requirements are as follows for power up when POWER_EN is not used to control switchable supplies:

1. V_{DDC} , V_{DD} , $\text{AV}_{\text{DD-PLAT}}$, $\text{AV}_{\text{DD-DDR}}$, LV_{DD2} , OV_{DD2} , $\text{AV}_{\text{DD-CORE0}}$, $\text{AV}_{\text{DD-CORE1}}$, BV_{DD} , LV_{DD} , OV_{DD} , SV_{DD} , SV_{DD2} , XV_{DD} , XV_{DD2} , SDAV_{DD} , SDAV_{DD2}
2. GV_{DD}

The requirements are as follows for power up when POWER_EN is used to control switchable supplies:

1. Always ON core supply: V_{DDC} , $\text{AV}_{\text{DD-PLAT}}$, $\text{AV}_{\text{DD-DDR}}$
2. Always ON I/O supply: LV_{DD2} , OV_{DD2} , GV_{DD}
 - Wait for POWER_EN to assert
3. Switchable core supply: V_{DD} , $\text{AV}_{\text{DD-CORE0}}$, $\text{AV}_{\text{DD-CORE1}}$
4. Switchable I/O supply: BV_{DD} , LV_{DD} , OV_{DD} , SV_{DD} , SV_{DD2} , XV_{DD} , XV_{DD2} , SDAV_{DD} and SDAV_{DD2}

The Serdes supplies SV_{DD} , SV_{DD2} , XV_{DD} , XV_{DD2} , SDAV_{DD} and SDAV_{DD2} can come up anytime after POWER_EN is asserted.

All supplies must be at their stable values within 50 ms.

Items on the same line have no ordering requirement with respect to one another. Items on separate lines must be ordered sequentially such that voltage rails on a previous step must reach 90% of their value before the voltage rails on the current step reach 10% of theirs.

In order to guarantee MCKE low during power-up, the above sequencing for GV_{DD} is required. If there is no concern about any of the DDR signals being in an indeterminate state during power-up, then the sequencing for GV_{DD} is not required.

NOTE

From a system standpoint, if any of the I/O power supplies ramp prior to the VDD core supply, the I/Os associated with that I/O supply may drive a logic one or zero during power-up, and extra current may be drawn by the device.

2.3 Power down requirements

The power-down cycle must complete such that power supply values are below 0.4 V before a new power-up cycle can be started.

2.4 RESET initialization

This section describes the AC electrical specifications for the RESET initialization timing requirements. This table provides the RESET initialization AC timing specifications.

Table 5. RESET initialization timing specifications

Parameter	Min	Max	Unit	Note
Required assertion time of $\overline{\text{HRESET}}$	25	—	μs	1, 2
Minimum assertion time of $\overline{\text{TRESET}}$ simultaneous to $\overline{\text{HRESET}}$ assertion	25	—	ns	3
Maximum rise/fall time of $\overline{\text{HRESET}}$	—	1	t_{SYSCLK}	—
Minimum assertion time for $\overline{\text{SRESET}}$	3	—	t_{SYSCLK}	4
PLL input setup time with stable SYSCLK before $\overline{\text{HRESET}}$ negation	100	—	μs	—
Input setup time for POR configurations (other than PLL configuration) with respect to negation of $\overline{\text{HRESET}}$	4	—	t_{SYSCLK}	4
Input hold time for all POR configurations (including PLL configuration) with respect to negation of $\overline{\text{HRESET}}$	2	—	t_{SYSCLK}	4
Maximum valid-to-high impedance time for actively driven POR configurations with respect to negation of $\overline{\text{HRESET}}$	—	5	t_{SYSCLK}	4, 5

Note:

1. There may be some extra current leakage when driving signals high during this time.
2. Reset assertion timing requirements for DDR3 DRAMs may differ.
3. TRST is an asynchronous level sensitive signal. For guidance on how this requirement can be met, refer to the JTAG signal termination guidelines in [Section 2.24, “JTAG controller.”](#)
4. SYSCLK is the primary clock input for the device. It must be ensured that SYSCLK is stable during $\overline{\text{HRESET}}$ assertion.
5. The POR pads are sampled for their POR configuration value till two cycles after HRESET deassertion. For the next 3 cycles, these pads transition from POR configuration pads to their respective primary function. During these 3 cycles, the POR pads should not be driven by external driver and the state of these pads should be ignored.

This table provides the PLL lock times.

Table 6. PLL lock times

Parameter	Min	Max	Unit	Note
PLL lock times	—	100	μs	—

2.5 Power-on ramp rate

This section describes the AC electrical specifications for the power-on ramp rate requirements. Controlling the maximum Power-On Ramp Rate is required to avoid falsely triggering the ESD circuitry. This table provides the power supply ramp rate specifications.

Table 7. Power supply ramp rate

Parameter	Min	Max	Unit	Note
Required ramp rate for all voltage supplies (including $\text{OV}_{\text{DD}}/\text{OV}_{\text{DD2}}$, $\text{GV}_{\text{DD}}/\text{BV}_{\text{DD}}/\text{SV}_{\text{DD}}/\text{LV}_{\text{DD}}/\text{LV}_{\text{DD2}}$, All V_{DD} supplies, MVREF and all AV_{DD} supplies.)	—	36000	Volts/s	1, 2

Table 7. Power supply ramp rate

Parameter	Min	Max	Unit	Note
-----------	-----	-----	------	------

Note:

1. Ramp rate is specified as a linear ramp from 10 to 90%. If non-linear (for example exponential), the maximum rate of change from 200 to 500 mV is the most critical as this range might falsely trigger the ESD circuitry.
2. Over full recommended operating temperature range (see Table 3).

2.6 Power characteristics

During deep sleep, the maximum power consumption of the device is expected to be below 300mW. This includes 260mW consumed by core as shown in the table below and ~40mW by I/Os on GV_{DD} , OV_{DD2} and LV_{DD2} power supplies.

This table shows the power dissipations of the VDD, VDDC, and SVDD supply for various operating platform clock frequencies versus the core and DDR clock frequencies.

Table 8. P1013 Core Power Dissipation

Core Frequency (MHz)	Platform Frequency (MHz)	DDR Data Rate (MT/s)	V_{DD} , V_{DDC} , S_{VDD} (V)	Junction Temp (°C)	Power Mode	Power (W)			Total Core and Platform Power (W) ¹	Note
						VDD ¹²	VDDC	SVDD ¹²		
1200	480	800	1.05	65	Typical	1.92	0.57	0.19	2.68	2, 3
					Thermal	2.84	0.85	0.19	3.88	5, 7
				Maximum		3.51	1.05	0.19	4.75	4, 6, 7
				65	Doze	1.67	0.62	0.19	2.48	8, 11
					Nap	1.52	0.72	0.19	2.42	8, 11
					Sleep	1.37	0.66	0.08	2.11	8, 11
35	Deep Sleep	0.00	0.27	0.00	0.27	8, 9, 10, 12				
1067	533	667	1.0	65	Typical	1.89	0.57	0.19	2.65	2, 3
					Thermal	2.80	0.84	0.19	3.83	5, 7
				Maximum		3.06	0.91	0.19	4.17	4, 6, 7
				125	Thermal	3.34	1.00	0.20	4.53	5, 7
					Maximum	3.48	1.04	0.20	4.72	4, 6, 7
				65	Doze	1.54	0.64	0.19	2.36	8, 11
					Nap	1.37	0.67	0.19	2.22	8, 11
					Sleep	1.18	0.63	0.08	1.89	8, 11
				35	Deep Sleep	0.00	0.26	0.00	0.26	8, 9, 10, 12

Table 8. P1013 Core Power Dissipation (continued)

Core Frequency (MHz)	Platform Frequency (MHz)	DDR Data Rate (MT/s)	V _{DD} , V _{DDC} , S _{VDD} (V)	Junction Temp (°C)	Power Mode	Power (W)			Total Core and Platform Power (W) ¹	Note
						VDD ¹²	VDDC	SVDD ¹²		
800	400	667	1.0	65	Typical	1.66	0.50	0.19	2.34	2, 3
					Thermal	2.56	0.77	0.19	3.52	5, 7
				Maximum		2.62	0.78	0.19	3.60	4, 6, 7
				125	Thermal	2.90	0.83	0.20	3.93	5, 7
					Maximum	2.99	0.89	0.20	4.08	4, 6, 7
				65	Doze	1.44	0.58	0.19	2.21	8, 11
					Nap	1.33	0.61	0.19	2.13	8, 11
					Sleep	1.16	0.56	0.08	1.80	8, 11
				35	Deep Sleep	0.00	0.26	0.00	0.26	8, 9, 10, 12
				600	400	667	1.0	65	Typical	1.54
Thermal	2.45	0.73	0.19						3.37	5, 7
	Maximum	2.66	0.80					0.19	3.65	4, 6, 7
125	Thermal	2.84	0.83					0.20	3.87	5, 7
	Maximum	2.933	0.89					0.20	4.02	4, 6, 7
65	Doze	1.37	0.55					0.19	2.10	8, 11
	Nap	1.28	0.57					0.19	2.03	8, 11
	Sleep	1.16	0.54					0.08	1.78	8, 11
35	Deep Sleep	0.00	0.26					0.00	0.26	8, 9, 10, 12

Note:

1. Combined power of VDDC, VDD and SVDDx with DDR Controller and all SerDes banks active. Does not include I/O power.
2. Typical power assumes Dhrystone running with activity factor of 80% (on all cores) and executing DMA on the platform with 90% activity factor.
3. Typical power is based on nominal processed device.
4. Maximum power assumes Multicore Dhrystone activity factor at 100% and executing DMA on the platform at 100% activity factor.
5. Thermal power assumes Multicore Dhrystone activity factor of 80% and executing DMA on the platform with 90% activity factor.
6. Maximum power is provided for power supply design sizing.
7. Thermal and Maximum power are based on worst case processed device.
8. All low power mode numbers are based on worst case processed device.
9. Deep Sleep power is the maximum number measured with USB1, eTSEC1 and DDR blocks enabled. It is characterized at 105°C.
10. Deep Sleep power is measured with DDR PLL disabled using DSCR[DDR_pll_disable].
11. These values specify the power consumption at nominal voltage and are meant for reference only.
12. VDD and SVDD are switched off during deep sleep mode.

2.6.1 I/O DC power supply recommendation

This table provides estimated I/O power numbers for each block: DDR, PCI Express, eLBC, eTSEC, SGMII, eSDHC, USB, eSPI, DUART, I²C, DIU, SSI, SATA, and GPIO.

Table 9. I/O power supply estimated values

Interface	Parameter	Symbol	Typical ¹	Maximum ⁷	Deep Sleep	Unit	Note
DDR2	400MT/s data rate	GV _{DD} (1.8 V)	0.700	1.000	—	W	2, 6
DDR3	600 MT/s data rate	GV _{DD} (1.5 V)	0.600	1.050	0.003	W	2, 6, 8
	667 MT/s data rate	GV _{DD} (1.5 V)	0.700	1.100	0.003	W	2, 6, 8
	800 MT/s data rate	GV _{DD} (1.5 V)	0.800	1.200	0.003	W	1, 2, 6, 8
PCI Express	x1, 2.5 G-baud	XV _{DD} (1.0 V)	0.020	0.020	—	W	—
	x2, 2.5 G-baud	XV _{DD} (1.0 V)	0.037	0.037	—	W	—
	x4, 2.5 G-baud	XV _{DD} (1.0 V)	0.075	0.075	—	W	—
SGMII	x1, 1.25G-baud	XV _{DD} (1.0 V)	0.014	0.014	—	W	—
SATA	3.0G-baud	XV _{DD2} (1.0 V)	0.022	0.022	—	W	—
eLBC	32-bit, 83MHz	BV _{DD} (1.8 V)	0.040	0.100	—	W	3
		BV _{DD} (2.5 V)	0.060	0.160	—	W	3
		BV _{DD} (3.3 V)	0.100	0.230	—	W	3
eLBC	16-bit, 83MHz	BV _{DD} (1.8 V)	0.017	0.025	—	W	3
		BV _{DD} (2.5 V)	0.030	0.038	—	W	3
		BV _{DD} (3.3 V)	0.047	0.063	—	W	3
eTSEC1	RGMII	LV _{DD2} (2.5 V)	0.075	0.100	0.015	W	3
		LV _{DD2} (3.3 V)	0.124	0.150	—	W	3
eTSEC2	RGMII	LV _{DD} (2.5 V)	0.075	0.100	—	W	3
		LV _{DD} (3.3 V)	0.124	0.150	—	W	3
eSDHC	—	O/BV _{DD} (3.3 V)	0.014	0.018	—	W	3
USB1	—	LV _{DD2} (3.3 V)	0.012	0.015	—	W	3
		LV _{DD2} (2.5 V)	0.008	0.010	0.005	W	3
USB2	—	LV _{DD} (3.3 V)	0.012	0.015	—	W	3
		LV _{DD} (2.5 V)	0.008	0.010	—	W	3
eSPI	—	BV _{DD} (1.8 V)	0.004	0.005	—	W	3
		BV _{DD} (2.5 V)	0.006	0.008	—	W	3
		BV _{DD} (3.3 V)	0.010	0.013	—	W	3
DIU	—	BV _{DD} (3.3 V)	0.180	0.225	—	W	3
I ² C	—	OV _{DD} (3.3 V)	0.002	0.003	—	W	3
DUART	—	OV _{DD} (3.3 V)	0.006	0.008	—	W	3
SSI	—	OV _{DD} (3.3 V)	0.005	0.006	—	W	3
TDM	—	OV _{DD} (3.3 V)	0.004	0.005	—	W	3

Table 9. I/O power supply estimated values (continued)

Interface	Parameter	Symbol	Typical ¹	Maximum ⁷	Deep Sleep	Unit	Note
IEEE1588	—	LV _{DD} (2.5 V)	0.004	0.005	—	W	3
		LV _{DD} (3.3 V)	0.007	0.009	—	W	3
GPIO	x8	3.3 V	0.009	0.011	—	W	3, 5
	x8	2.5 V	0.007	0.009	—	W	3, 5
	x8	1.8 V	0.005	0.006	—	W	3, 5
Others (Reset, System Clock, JTAG and Misc)	—	OV _{DD2} (3.3 V)	0.030	0.036	0.015	W	3, 5

Note:

1. Typical values are estimates based on simulations at 65°C
2. Typical DDR power numbers are based on 1Rank DIMM with 40% utilization.
3. Assuming 15 pF total capacitance load per pin.
4. GPIOs are supported on OV_{DD2}, OV_{DD}, LV_{DD}, LV_{DD2} and BV_{DD} power rails.
5. Maximum DDR power numbers are based on 2 Rank DIMM with 75% utilization.
6. Maximum values are estimates based on simulations at 105 °C. The values are not intended to be used as the maximum guaranteed current.
7. Assuming DDR I/Os tristated in deep sleep.

2.7 Input clocks

This table provides the system clock (SYSCLK) and DDR clock (DDRCLK) DC specifications for the device.

Table 10. SYSCLK/DDRCLK DC electrical characteristics (OV_{DD2} = 3.3 V ± 165 mV)

Parameter	Symbol	Min	Typical	Max	Unit	Note
High-level input voltage	V _{IH}	2.0	—	—	V	1
Low-level input voltage	V _{IL}	—	—	0.8	V	1
Input Capacitance	C _{IN}	—	7	15	pf	—
Input current (V _{IN} = 0 V or V _{IN} = V _{DD})	I _{IN}	—	—	±50	μA	2

Note:

1. The max V_{IH}, and min V_{IL} values can be found in [Table 3](#).
2. The symbol V_{IN}, in this case, represents the OV_{IN} symbol referenced in [Table 3](#).

This table provides the system clock (SYSCLK) and DDR clock (DDRCLK) AC timing specifications for the device.

Table 11. SYSCLK/DDRCLK AC timing specifications

At recommended operating conditions (see [Table 3](#)) with OV_{DD2} = 3.3 V ± 165 mV.

Parameter/Condition	Symbol	Min	Typ	Max	Unit	Note
SYSCLK frequency	f _{SYSCLK}	66	—	133	MHz	1, 2
SYSCLK cycle time	t _{SYSCLK}	7.5	—	15	ns	1, 2
DDRCLK frequency	f _{DDRCLK}	66	—	133	MHz	1, 2
DDRCLK cycle time	t _{DDRCLK}	7.5	—	15	ns	1, 2

Electrical characteristics

Table 11. SYSCLK/DDRCLK AC timing specifications (continued)

At recommended operating conditions (see Table 3) with $OV_{DD2} = 3.3\text{ V} \pm 165\text{ mV}$.

Parameter/Condition	Symbol	Min	Typ	Max	Unit	Note
SYSCLK/DDRCLK duty cycle	$t_{KHK}/$ $t_{SYSCLK/DDRCLK}$	40	—	60	%	2
SYSCLK/DDRCLK slew rate	—	1	—	4	V/ns	3
SYSCLK/DDRCLK peak period jitter	—	—	—	± 150	ps	—
SYSCLK/DDRCLK jitter phase noise at -56dBc	—	—	—	500	KHz	4
AC Input Swing Limits at 3.3 V OV_{DD2}	ΔV_{AC}	1.9	—	—	V	—

Note:

1. **Caution:** The relevant clock ratio settings must be chosen such that the resulting SYSCLK/DDRCLK frequency, do not exceed their respective maximum or minimum operating frequencies.
2. Measured at the rising edge and/or the falling edge at $OV_{DD2}/2$.
3. Slew rate as measured from $\pm 0.3 \Delta V_{AC}$ at center of peak to peak voltage at clock input.
4. Phase noise is calculated as FFT of TIE jitter.

2.7.1 Spread spectrum sources

Spread spectrum clock sources are an increasingly popular way to control electromagnetic interference emissions (EMI) by spreading the emitted noise to a wider spectrum and reducing the peak noise magnitude in order to meet industry and government requirements. These clock sources intentionally add long-term jitter in order to diffuse the EMI spectral content. The jitter specification given in Table 11 considers short-term (cycle-to-cycle) jitter only and the clock generator's cycle-to-cycle output jitter should meet P1013's input cycle-to-cycle jitter requirement. Frequency modulation and spread are separate concerns, and P1013 is compatible with spread spectrum sources if the recommendations listed in Table 11 are observed.

Table 12. Spread spectrum clock source recommendations

At recommended operating conditions (see Table 3) with $OV_{DD2} = 3.3\text{ V} \pm 165\text{ mV}$.

Parameter	Min	Max	Unit	Note
Frequency modulation	—	60	kHz	—
Frequency spread	—	1.0	%	1, 2

Note:

1. SYSCLK frequencies resulting from frequency spreading, and the resulting core frequency, must meet the minimum and maximum specifications given in Table 11.
2. Maximum spread spectrum frequency may not result in exceeding any maximum operating frequency of the device

CAUTION

The processor's minimum and maximum SYSCLK/DDRCLK and core/DDR memory frequencies must not be exceeded regardless of the type of clock source. Therefore, systems in which the processor is operated at its maximum rated core/DDR memory frequency should avoid violating the stated limits by using down-spreading only.

2.7.2 Real time clock timing

The real time clock timing (RTC_CLK) input is sampled by the core complex bus clock (CCB_clk). The output of the sampling latch is then used as an input to the counters of the PIC and the time base unit of the e500; there is no need for jitter specification. The minimum pulse width of RTC_CLK must be greater than 16x of the CCB clock. That is minimum clock high time is $16 \times t_{CCB_clk}$, and minimum clock low time is $16 \times t_{CCB_clk}$. There is no minimum RTC_CLK frequency; RTC_CLK may be grounded if not needed. If used the edge rate for RTC_CLK must be within $10\text{ns} \pm 2\%$.

2.7.3 eTSEC Gigabit reference clock timing

This table provides the eTSEC gigabit reference clocks (EC_GTX_CLK125) AC timing specifications for the device.

Table 13. EC_GTX_CLK125 AC timing specifications

At recommended operating conditions with $LV_{DD} = 2.5 \pm 0.125 \text{ mV} / 3.3 \text{ V} \pm 165 \text{ mV}$

Parameter/Condition	Symbol	Min	Typical	Max	Unit	Note
EC_GTX_CLK125 frequency	t_{G125}	—	125	—	MHz	—
EC_GTX_CLK125 cycle time	t_{G125}	—	8	—	ns	—
EC_GTX_CLK125 rise and fall time $LV_{DD} = 2.5 \text{ V}$ $LV_{DD} = 3.3 \text{ V}$	t_{G125R}/t_{G125F}	—	—	0.75 1.0	ns	1
EC_GTX_CLK125 duty cycle	t_{G125H}/t_{G125L}	47	—	53	%	2
EC_GTX_CLK125 total jitter	—	—	—	± 150	ps	2

Note:

- Rise and fall times for EC_GTX_CLK125 are measured from 0.5 and 2.0 V for $LV_{DD} = 2.5 \text{ V}$, and from 0.6 and 2.7 V for $LV_{DD} = 3.3 \text{ V}$
- EC_GTX_CLK125 is used to generate the GTX clock for the eTSEC transmitter with 2% degradation. EC_GTX_CLK125 duty cycle can be loosened from 47%/53% as long as the PHY device can tolerate the duty cycle generated by the eTSEC GTX_CLK. See [Table 34](#) for duty cycle for 10Base-T and 100Base-T reference clock.

2.7.4 Other input clocks

A description of the overall clocking of this device is available in the *P1022 QorIQ Integrated Processor Reference Manual* in the form of a Clock Subsystem Block Diagram. For information on the input clock requirements of functional blocks sourced external of the device, such as SerDes, Ethernet Management, eSDHC, enhanced Local Bus, see the specific interface section.

2.8 DDR2 and DDR3 SDRAM controller

This section describes the DC and AC electrical specifications for the DDR2 and DDR3 SDRAM controller interface of the device. Note that the required $GV_{DD}(\text{typ})$ voltage is 1.8V or 1.5V when interfacing to DDR2 or DDR3 SDRAM respectively.

2.8.1 DDR2 and DDR3 SDRAM interface DC electrical characteristics

This table provides the recommended operating conditions for the DDR SDRAM Controller of the device when interfacing to DDR2 SDRAM.

Table 14. DDR2 SDRAM Interface DC electrical characteristics for $GV_{DD}(\text{typ}) = 1.8 \text{ V}^1$

Parameter/Condition	Symbol	Min	Max	Unit	Note
I/O reference voltage	MVREF _n	$0.49 \times GV_{DD}$	$0.51 \times GV_{DD}$	V	2, 3, 4

Electrical characteristics

Table 14. DDR2 SDRAM Interface DC electrical characteristics for $GV_{DD}(\text{typ}) = 1.8 \text{ V}^1$ (continued)

Parameter/Condition	Symbol	Min	Max	Unit	Note
Input high voltage	V_{IH}	$MVREFn + 0.125$	—	V	5
Input low voltage	V_{IL}	—	$MVREFn - 0.125$	V	5
I/O leakage current	I_{OZ}	-50	50	μA	8
Output high current ($V_{OUT} = 1.370 \text{ V}$)	I_{OH}	—	-13.4	mA	6, 7
Output low current ($V_{OUT} = 0.330 \text{ V}$)	I_{OL}	13.4	—	mA	6, 7

Note:

- GV_{DD} is expected to be within 50 mV of the DRAM's voltage supply at all times. The DRAM's and memory controller's voltage supply may or may not be from the same source.
- $MVREFn$ is expected to be equal to $0.5 \times GV_{DD}$, and to track GV_{DD} DC variations as measured at the receiver. Peak-to-peak noise on $MVREFn$ may not exceed $\pm 2\%$ of the DC value.
- V_{TT} is not applied directly to the device. It is the supply to which far end signal termination is made and is expected to be equal to $MVREFn$ with min value of $MVREFn - 0.04$, and max value of $MVREFn + 0.04$. This rail should track variations in the DC level of $MVREFn$.
- The voltage regulator for $MVREFn$ must meet the specifications stated in [Table 17](#).
- Input capacitance load for DQ, DQS and \overline{DQS} are available in the IBIS models,
- I_{OH} and I_{OL} are measured at $GV_{DD} = 1.7 \text{ V}$
- Refer to the IBIS model for the complete output IV curve characteristics.
- Output leakage is measured with all outputs disabled, $0 \text{ V} \leq V_{OUT} \leq GV_{DD}$

This table provides the recommended operating conditions for the DDR SDRAM Controller of the device when interfacing to DDR3 SDRAM.

Table 15. DDR3 SDRAM interface DC electrical characteristics for $GV_{DD}(\text{typ}) = 1.5 \text{ V}^1$

Parameter/Condition	Symbol	Min	Max	Unit	Note
I/O reference voltage	$MVREFn$	$0.49 \times GV_{DD}$	$0.51 \times GV_{DD}$	V	2, 3, 4
Input high voltage	V_{IH}	$MVREFn + 0.100$	GV_{DD}	V	5
Input low voltage	V_{IL}	GND	$MVREFn - 0.100$	V	5
I/O leakage current	I_{OZ}	-50	50	μA	6

Note:

- GV_{DD} is expected to be within 50 mV of the DRAM's voltage supply at all times. The DRAM's and memory controller's voltage supply may or may not be from the same source.
- $MVREFn$ is expected to be equal to $0.5 \times GV_{DD}$, and to track GV_{DD} DC variations as measured at the receiver. Peak-to-peak noise on $MVREFn$ may not exceed $\pm 1\%$ of the DC value.
- V_{TT} is not applied directly to the device. It is the supply to which far end signal termination is made and is expected to be equal to $MVREFn$ with min value of $MVREFn - 0.04$, and max value of $MVREFn + 0.04$. This rail should track variations in the DC level of $MVREFn$.
- The voltage regulator for $MVREFn$ must meet the specifications stated in [Table 17](#).
- Input capacitance load for DQ, DQS and \overline{DQS} are available in the IBIS models
- Output leakage is measured with all outputs disabled, $0 \text{ V} \leq V_{OUT} \leq GV_{DD}$.

This table provides the DDR Controller interface capacitance for DDR2 and DDR3.

Table 16. DDR2/DDR3 SDRAM capacitance for $GV_{DD}(\text{typ}) = 1.8 \text{ V}$ and 1.5 V

Parameter/Condition	Symbol	Min	Max	Unit	Note
Input/output capacitance: DQ, DQS, \overline{DQS}	C_{IO}	6	8	pF	1, 2
Delta input/output capacitance: DQ, DQS, \overline{DQS}	C_{DIO}	—	0.5	pF	1, 2

Note:

1. This parameter is sampled. $GV_{DD} = 1.8 \text{ V} \pm 0.1 \text{ V}$ (for DDR2), $f = 1 \text{ MHz}$, $T_A = 25^\circ\text{C}$, $V_{OUT} = GV_{DD}/2$, V_{OUT} (peak-to-peak) = 0.2 V.
2. This parameter is sampled. $GV_{DD} = 1.5 \text{ V} \pm 0.075 \text{ V}$ (for DDR3), $f = 1 \text{ MHz}$, $T_A = 25^\circ\text{C}$, $V_{OUT} = GV_{DD}/2$, V_{OUT} (peak-to-peak) = 0.150V.

This table provides the current draw characteristics for MVREFn.

Table 17. Current draw characteristics for MVREFn

Parameter/Condition	Symbol	Min	Max	Unit	Note
Current draw for DDR2 SDRAM for MVREFn	MVREFn	—	1500	μA	—
Current draw for DDR3 SDRAM for MVREFn	MVREFn	—	1250	μA	—

2.8.2 DDR2 and DDR3 SDRAM interface AC electrical characteristics

This section provides the AC electrical characteristics for the DDR SDRAM Controller interface. The DDR controller supports both DDR2 and DDR3 memories.

2.8.3 DDR2 and DDR3 SDRAM interface input AC timing specifications

This table provides the input AC timing specifications for the DDR controller when interfacing to DDR2 SDRAM.

Table 18. DDR2 SDRAM interface input AC timing specifications

At recommended operating conditions with GV_{DD} of $1.8 \text{ V} \pm 5\%$

Parameter	Symbol	Min	Max	Unit	Note	
AC input low voltage	V_{ILAC}	> 533 MT/s data rate	—	$MVREFn - 0.20$	V	—
		$\leq 533 \text{ MT/s}$ data rate	—	$MVREFn - 0.25$		
AC input high voltage	V_{IHAC}	> 533 MT/s data rate	$MVREFn + 0.20$	—	V	—
		$\leq 533 \text{ MT/s}$ data rate	$MVREFn + 0.25$	—		

This table provides the input AC timing specifications for the DDR controller when interfacing to DDR3 SDRAM.

Table 19. DDR3 SDRAM interface input AC timing specifications

At recommended operating conditions with GV_{DD} of $1.5 \text{ V} \pm 5\%$

Parameter	Symbol	Min	Max	Unit	Note
AC input low voltage	V_{ILAC}	—	$MVREFn - 0.175$	V	—
AC input high voltage	V_{IHAC}	$MVREFn + 0.175$	—	V	—

This table provides the input AC timing specifications for the DDR controller when interfacing to DDR2 and DDR3 SDRAM.

Electrical characteristics

Table 20. DDR2 and DDR3 SDRAM interface input AC timing specifications

At recommended operating conditions with GV_{DD} of 1.8 V \pm 5% for DDR2 or 1.5 V \pm 5% for DDR3.

Parameter	Symbol	Min	Max	Unit	Note
Controller Skew for MDQS—MDQ/MECC	t_{CISKEW}	—	—	ps	1
800 MT/s data rate		-350	350		
667 MT/s data rate		-390	390		
Tolerated Skew for MDQS—MDQ/MECC	t_{DISKEW}	—	—	ps	2
800 MT/s data rate		-275	275		
667 MT/s data rate		-360	360		

Note:

1. t_{CISKEW} represents the total amount of skew consumed by the controller between MDQS[n] and any corresponding bit that is captured with MDQS[n]. This must be subtracted from the total timing budget.
2. The amount of skew that can be tolerated from MDQS to a corresponding MDQ signal is called t_{DISKEW} . This can be determined by the following equation: $t_{DISKEW} = \pm(T/4 - \text{abs}(t_{CISKEW}))$ where T is the clock period and $\text{abs}(t_{CISKEW})$ is the absolute value of t_{CISKEW} .

This figure shows the DDR2 and DDR3 SDRAM interface input timing diagram.

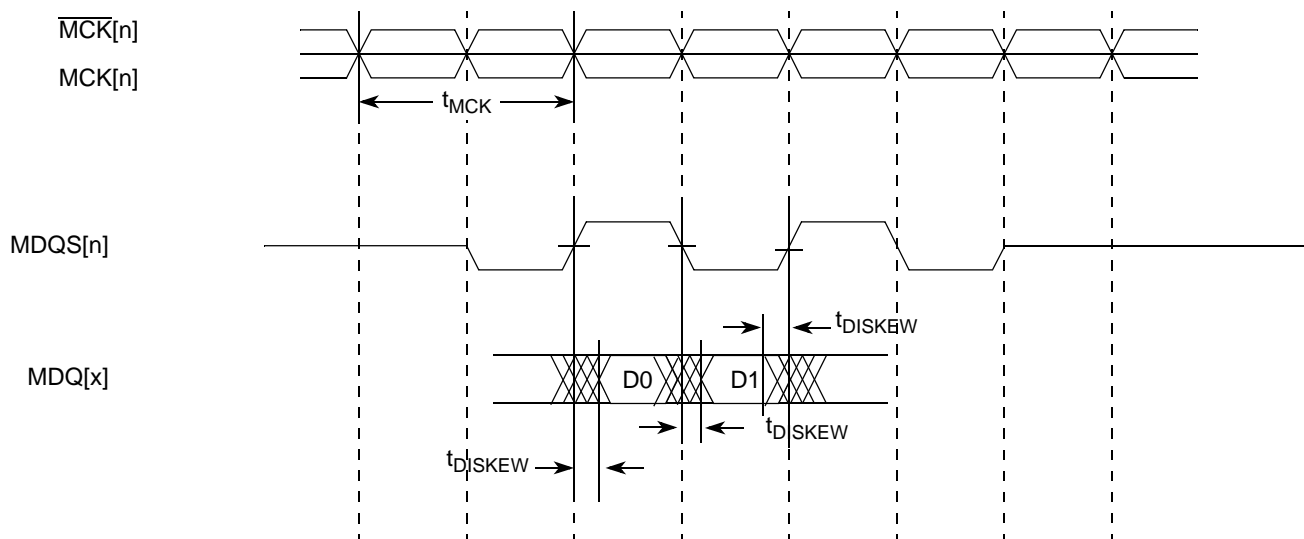

Figure 8. DDR SDRAM interface input timing diagram

2.8.4 DDR2 and DDR3 SDRAM interface output AC timing specifications

This table contains the output AC timing targets for the DDR2 and DDR3 SDRAM interface.

Table 21. DDR2 and DDR3 SDRAM interface output AC timing specifications

At recommended operating conditions with GV_{DD} of 1.8 V \pm 5% for DDR2 or 1.5 V \pm 5% for DDR3.

Parameter	Symbol ¹	Min	Max	Unit	Note
MCK[n] cycle time	t_{MCK}	3	5	ns	2
ADDR/CMD output setup with respect to MCK 800 MT/s data rate 667 MT/s data rate	t_{DDKHAS}	0.767 0.95	—	ns	3
ADDR/CMD output hold with respect to MCK 800 MT/s data rate 667 MT/s data rate	t_{DDKHAX}	0.767 0.95	—	ns	3
$\overline{MCS}[n]$ output setup with respect to MCK 800 MT/s data rate 667 MT/s data rate	t_{DDKHCS}	0.767 0.95	—	ns	3
$\overline{MCS}[n]$ output hold with respect to MCK 800 MT/s data rate 667 MT/s data rate	t_{DDKHCX}	0.767 0.95	—	ns	3
MCK to MDQS Skew 800 MT/s data rate 667 MT/s data rate	t_{DDKMHM}	-0.525 -0.6	0.525 0.6	ns	4
MDQ/MECC/MDM output setup with respect to MDQS 800 MT/s data rate 667 MT/s data rate	t_{DDKHDS} , t_{DDKLDS}	225 325	—	ps	5
MDQ/MECC/MDM output hold with respect to MDQS 800 MT/s data rate 667 MT/s data rate	t_{DDKHDX} , t_{DDKLDX}	225 325	—	ps	5
MDQS preamble	t_{DDKHMP}	$0.9 \times t_{MCK}$	—	ns	
MDQS postamble	t_{DDKHME}	$0.4 \times t_{MCK}$	$0.6 \times t_{MCK}$	ns	

Electrical characteristics

Table 21. DDR2 and DDR3 SDRAM interface output AC timing specifications (continued)

At recommended operating conditions with V_{DD} of 1.8 V \pm 5% for DDR2 or 1.5 V \pm 5% for DDR3.

Parameter	Symbol ¹	Min	Max	Unit	Note
-----------	---------------------	-----	-----	------	------

Note:

1. The symbols used for timing specifications follow the pattern of $t_{(\text{first two letters of functional block})(\text{signal})(\text{state}) (\text{reference})(\text{state})}$ for inputs and $t_{(\text{first two letters of functional block})(\text{reference})(\text{state})(\text{signal})(\text{state})}$ for outputs. Output hold time can be read as DDR timing (DD) from the rising or falling edge of the reference clock (KH or KL) until the output went invalid (AX or DX). For example, t_{DDKHAS} symbolizes DDR timing (DD) for the time t_{MCK} memory clock reference (K) goes from the high (H) state until outputs (A) are setup (S) or output valid time. Also, t_{DDKLDX} symbolizes DDR timing (DD) for the time t_{MCK} memory clock reference (K) goes low (L) until data outputs (D) are invalid (X) or data output hold time.
2. All MCK/MCK referenced measurements are made from the crossing of the two signals.
3. ADDR/CMD includes all DDR SDRAM output signals except MCK/MCK, MCS, and MDQ/MECC/MDM/MDQS.
4. Note that t_{DDKHMH} follows the symbol conventions described in note 1. For example, t_{DDKHMH} describes the DDR timing (DD) from the rising edge of the MCK[n] clock (KH) until the MDQS signal is valid (MH). t_{DDKHMH} can be modified through control of the MDQS override bits (called WR_DATA_DELAY) in the TIMING_CFG_2 register. This is typically set to the same delay as in DDR_SDRAM_CLK_CNTL[CLK_ADJUST]. The timing parameters listed in the table assume that these 2 parameters have been set to the same adjustment value. See the *P1022 QorIQ Integrated Processor Reference Manual* for a description and understanding of the timing modifications enabled by use of these bits.
5. Determined by maximum possible skew between a data strobe (MDQS) and any corresponding bit of data (MDQ), ECC (MECC), or data mask (MDM). The data strobe must be centered inside of the data eye at the pins of the microprocessor.

NOTE

For the ADDR/CMD setup and hold specifications in Table 21, it is assumed that the clock control register is set to adjust the memory clocks by 1/2 applied cycle.

This figure shows the DDR2 and DDR3 SDRAM Interface output timing for the MCK to MDQS skew measurement (t_{DDKHMH}).

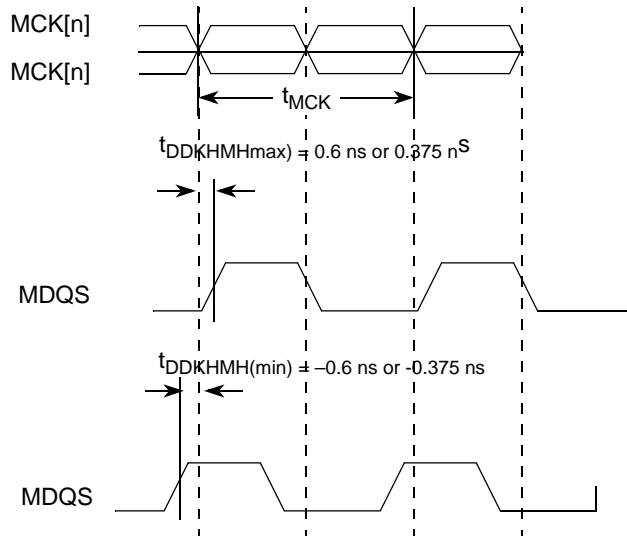

Figure 9. Timing diagram for t_{DDKHMH}

This figure shows the DDR2 and DDR3 SDRAM output timing diagram.

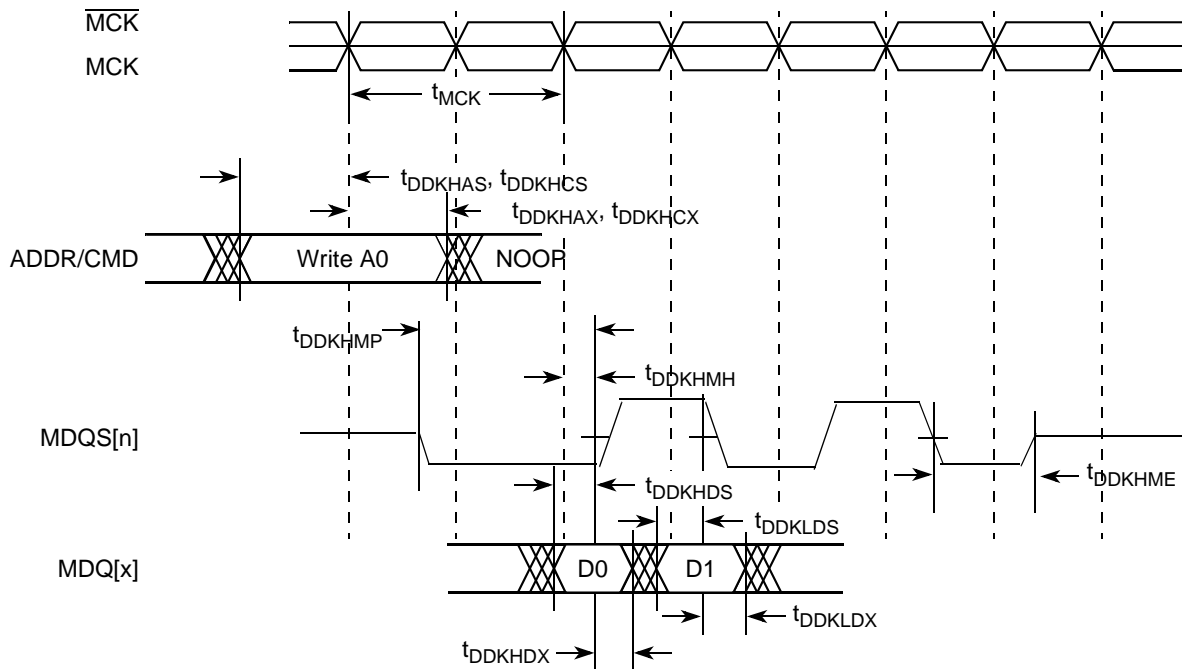

Figure 10. DDR2 and DDR3 SDRAM output timing diagram

This figure provides the AC test load for the DDR2 and DDR3 Controller bus.

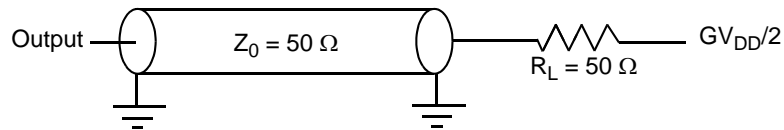

Figure 11. DDR2 and DDR3 controller bus AC test load

2.8.5 DDR2 and DDR3 SDRAM differential timing specifications

This section describes the DC and AC differential electrical specifications for the DDR2 and DDR3SDRAM controller interface of the device.

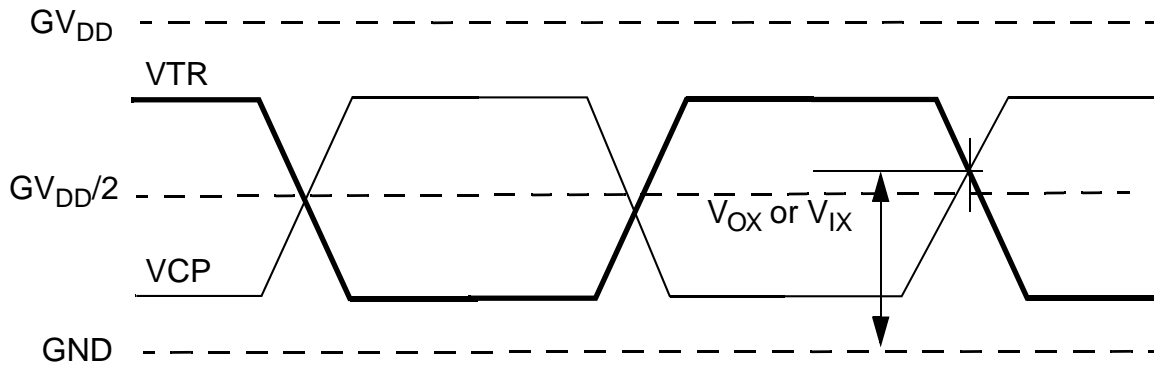

Figure 12. DDR2 and DDR3 SDRAM differential timing specifications

NOTE

VTR specifies the true input signal (such as MCK or MDQS) and VCP is the complementary input signal (such as $\overline{\text{MCK}}$ or $\overline{\text{MDQS}}$).

This table provides the differential specifications for P1013 differential signals $\overline{\text{MDQS}}/\overline{\text{MDQS}}$ and $\overline{\text{MCK}}/\overline{\text{MCK}}$ in DDR2 mode.

Table 22. DDR2 SDRAM differential electrical characteristics

Parameter/Condition	Symbol	Min	Max	Unit	Note
Input AC Differential Cross-point Voltage	V_{IXAC}	$0.5 \times GV_{DD} - 0.175$	$0.5 \times GV_{DD} + 0.175$	V	1
Output AC Differential Cross-point Voltage	V_{OXAC}	$0.5 \times GV_{DD} - 0.125$	$0.5 \times GV_{DD} - 0.125$	V	1

Note:

1. I/O drivers are calibrated before making measurements.

This table provides the differential specifications for the differential signals $\overline{\text{MDQS}}/\overline{\text{MDQS}}$ and $\overline{\text{MCK}}/\overline{\text{MCK}}$ in DDR3 mode.

Table 23. DDR3 SDRAM differential electrical characteristics

Parameter/Condition	Symbol	Min	Max	Unit	Note
Input AC Differential Cross-point Voltage	V_{IXAC}	$0.5 \times GV_{DD} - 0.150$	$0.5 \times GV_{DD} + 0.150$	V	1
Output AC Differential Cross-point Voltage	V_{OXAC}	$0.5 \times GV_{DD} - 0.115$	$0.5 \times GV_{DD} - 0.115$	V	1

Note:

1. I/O drivers are calibrated before making measurements.

2.9 eSPI

This section describes the DC and AC electrical specifications for the eSPI of the device.

2.9.1 eSPI DC electrical characteristics

This table provides the DC electrical characteristics for the eSPI interface operating at 3.3 V.

Table 24. eSPI DC electrical characteristics (3.3 V)

Characteristic	Symbol	Condition	Min	Max	Unit	Note
Input high voltage	V_{IH}	—	2.0	—	V	1
Input low voltage	V_{IL}	—	—	0.8	V	1
Input current	I_{IN}	$V_{IN} = 0V$ or $V_{IN} = BV_{DD}$	—	± 40	μA	2
Output high voltage	V_{OH}	$I_{OH} = -2.0$ mA	2.4	—	V	—
Output low voltage	V_{OL}	$I_{OL} = 2.0$ mA	—	0.4	V	—

Note:

1. The min V_{IL} and max V_{IH} values are based on the respective min and max BV_{DD} values found in [Table 2](#).
2. The symbol V_{IN} , represents BV_{DD} referenced in [Table 2](#).

This table provides the DC electrical characteristics for the eSPI interface operating at 2.5 V.

Table 25. eSPI DC electrical characteristics (2.5 V)

Characteristic	Symbol	Condition	Min	Max	Unit	Note
Input high voltage	V_{IH}	—	1.7	—	V	1
Input low voltage	V_{IL}	—	—	0.7	V	1
Input current	I_{IN}	$V_{IN} = 0V$ or $V_{IN} = BV_{DD}$	—	± 40	μA	2
Output high voltage	V_{OH}	$I_{OH} = -1.0$ mA	2.0	—	V	—
Output low voltage	V_{OL}	$I_{OL} = 1.0$ mA	—	0.4	V	—

Note:

1. The min V_{IL} and max V_{IH} values are based on the respective min and max BV_{DD} values found in [Table 2](#).
2. The symbol V_{IN} , represents BV_{DD} referenced in [Table 2](#).

This table provides the DC electrical characteristics for the eSPI interface operating at 1.8 V.

Table 26. eSPI DC electrical characteristics (1.8 V)

Characteristic	Symbol	Condition	Min	Max	Unit	Note
Input high voltage	V_{IH}	—	1.25	—	V	1
Input low voltage	V_{IL}	—	—	0.6	V	1
Input current	I_{IN}	$V_{IN} = 0V$ or $V_{IN} = BV_{DD}$	—	± 40	μA	2
Output high voltage	V_{OH}	$I_{OH} = -0.5$ mA	1.35	—	V	—
Output low voltage	V_{OL}	$I_{OL} = 0.5$ mA	—	0.4	V	—

Electrical characteristics

Table 26. eSPI DC electrical characteristics (1.8 V) (continued)

Characteristic	Symbol	Condition	Min	Max	Unit	Note
----------------	--------	-----------	-----	-----	------	------

Note:

1. The min V_{IL} and max V_{IH} values are based on the respective min and max BV_{DD} values found in [Table 2](#).
2. The symbol V_{IN} , represents BV_{DD} referenced in [Table 2](#).

2.9.2 eSPI AC timing specifications

This table and provide the eSPI input and output AC timing specifications.

Table 27. eSPI AC Timing Specifications¹

Characteristic	Symbol ²	Min	Max	Unit	Note
SPI_MOSI output—Master data (internal clock) hold time	t_{NIKH0X}	$0.5+(t_{PLATFORM_CLK} * SPMODE[HO_ADJ])$	—	ns	1, 3
SPI_MOSI output—Master data (internal clock) delay	t_{NIKH0V}	—	$5.5+(t_{PLATFORM_CLK} * SPMODE[HO_ADJ])$	ns	1, 3
SPI_CS outputs—Master data (internal clock) hold time	$t_{NIKH0X2}$	0	—	ns	1
SPI_CS outputs—Master data (internal clock) delay	$t_{NIKH0V2}$	—	5.5	ns	1
SPI inputs—Master data (internal clock) input setup time	t_{NIIVKH}	5	—	ns	—
SPI inputs—Master data (internal clock) input hold time	t_{NIIXKH}	0	—	ns	—

Note:

1. Output specifications are measured from the 50% level of the rising edge of CLKIN to the 50% level of the signal. Timings are measured at the pin.
2. The symbols used for timing specifications follow the pattern of $t_{(first\ two\ letters\ of\ functional\ block)(signal)(state)\ (reference)(state)}$ for inputs and $t_{(first\ two\ letters\ of\ functional\ block)(reference)(state)(signal)(state)}$ for outputs. For example, t_{NIKH0V} symbolizes the NMSI outputs internal timing (NI) for the time t_{SPI} memory clock reference (K) goes from the high state (H) until outputs (O) are valid (V).
3. See *P1022 QorIQ Integrated Processor Reference Manual* for detail about the register SPMODE.

This figure provides the AC test load for the eSPI.

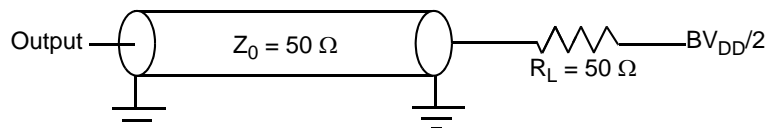
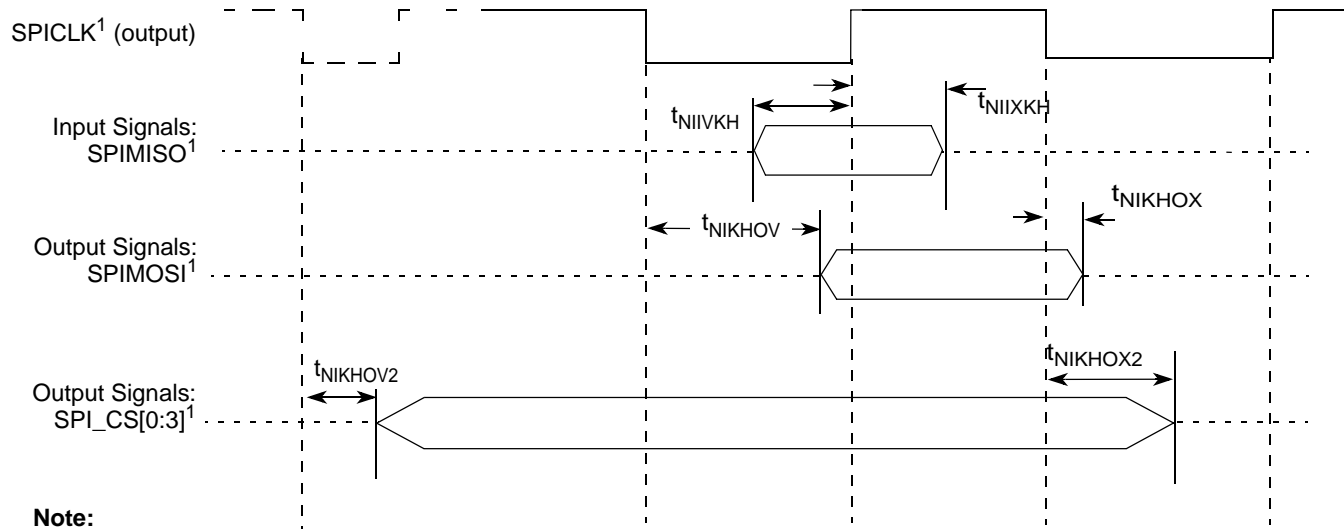

Figure 13. eSPI AC test load

This figure represents the AC timing from Table 27 in master mode (internal clock). (It apply when $SPMODEx[CIx] = 0$, $SPMODEx[CPx] = 0$.) Note that the clock edge is selectable on SPI.

**Note:**

1. SPICLK appears on the interface only after CS assertion.

Figure 14. SPI AC timing in master mode (internal clock) diagram

2.10 DUART

This section describes the DC and AC electrical specifications for the DUART interface of the device.

2.10.1 DUART DC electrical characteristics

This table provides the DC electrical characteristics for the DUART interface.

Table 28. DUART DC electrical characteristics

Parameter	Symbol	Min	Max	Unit	Note
High-level input voltage	V_{IH}	2	—	V	1
Low-level input voltage	V_{IL}	—	0.8	V	1
Input current ($OV_{IN} = 0\text{ V}$ or $OV_{IN} = OV_{DD}$)	I_{IN}	—	± 40	μA	2
High-level output voltage ($OV_{DD} = \text{min}$, $I_{OH} = -2\text{ mA}$)	V_{OH}	2.4	—	V	—
Low-level output voltage ($OV_{DD} = \text{min}$, $I_{OL} = 2\text{ mA}$)	V_{OL}	—	0.4	V	—

Note:

1. The min V_{IL} and max V_{IH} values are based on the min and max OV_{IN} respective values found in Table 3.
2. The symbol V_{IN} , in this case, represents the OV_{IN} symbol referenced in Table 3.

2.10.2 DUART AC electrical specifications

This table provides the AC timing parameters for the DUART interface.

Table 29. DUART AC timing specifications

Parameter	Value	Unit	Note
Minimum baud rate	$f_{CCB}/1,048,576$	baud	1
Maximum baud rate	$f_{CCB}/16$	baud	1, 2
Oversample rate	16	—	3

Note:

1. f_{CCB} refers to the internal platform clock.
2. Actual attainable baud rate is limited by the latency of interrupt processing.
3. The middle of a start bit is detected as the 8th sampled 0 after the 1-to-0 transition of the start bit. Subsequent bit values are sampled each 16th sample.

2.11 Ethernet: Enhanced Three-Speed Ethernet (eTSEC), MII management

This section provides the AC and DC electrical characteristics for enhanced three-speed Ethernet controller and the MII management interface.

2.11.1 RMII/RGMII DC electrical characteristics

All RMII/RGMII drivers and receivers comply with the DC parametric attributes specified in [Table 30](#) and [Table 31](#).

Table 30. RMII DC electrical characteristics @ $LV_{DD} = 3.3\text{ V}$

Parameter	Symbol	Min	Max	Unit	Note
Supply voltage, 3.3 V	LV_{DD}	3.13	3.47	V	—
Output high voltage ($LV_{DD} = \text{min}$, $I_{OH} = -4.0\text{ mA}$)	V_{OH}	2.1	$LV_{DD} + 0.3$	V	—
Output low voltage ($LV_{DD} = \text{min}$, $I_{OL} = 4.0\text{ mA}$)	V_{OL}	GND	0.50	V	—
Input high voltage RMII	V_{IH}	2.0	—	V	—
Input low voltage	V_{IL}	—	0.90	V	—
Input high current ($V_{IN} = LV_{DD}$)	I_{IH}	—	40	μA	1
Input low current ($V_{IN} = \text{GND}$)	I_{IL}	-600	—	μA	1

Note:

1. The symbol V_{IN} , in this case, represents the LV_{IN} symbols referenced in [Table 2](#) and [Table 3](#).

Table 31. RMII/RGMII DC electrical characteristics @ $LV_{DD} = 2.5\text{ V}$

Parameters	Symbol	Min	Max	Unit	Note
Supply voltage, 2.5 V	LV_{DD}	2.37	2.63	V	1
Output high voltage ($LV_{DD} = \text{min}$, $I_{OH} = -1.0\text{ mA}$)	V_{OH}	2.00	$LV_{DD} + 0.3$	V	—
Output low voltage ($LV_{DD} = \text{min}$, $I_{OL} = 1.0\text{ mA}$)	V_{OL}	$\text{GND} - 0.3$	0.40	V	—
Input high voltage	V_{IH}	1.70	—	V	—

Table 31. RMII/RGMII DC electrical characteristics (continued)@ LV_{DD} = 2.5 V

Parameters	Symbol	Min	Max	Unit	Note
Input low voltage	V _{IL}	—	0.70	V	—
Input high current (V _{IN} = LV _{DD})	I _{IH}	—	10	μA	—
Input low current (V _{IN} = GND)	I _{IL}	-15	—	μA	1

Note:

1. The symbol V_{IN}, in this case, represents the LV_{IN} symbols referenced in Table 2 and Table 3.

2.11.2 RMII/RGMII AC timing specifications

This section describes the RMII transmit and receive AC timing specifications and then the RGMII AC timing specifications

2.11.2.1 RMII transmit AC timing specifications

The RMII transmit AC timing specifications are in this table.

Table 32. RMII transmit AC timing specifications

For recommended operating conditions, see Table 3.

Parameter/Condition	Symbol	Min	Typ	Max	Unit
TSEC _n _TX_CLK clock period	t _{RMT}	—	20.0	—	ns
TSEC _n _TX_CLK duty cycle	t _{RMTH}	35	—	65	%
TSEC _n _TX_CLK peak-to-peak jitter	t _{RMTJ}	—	—	250	ps
Rise time TSEC _n _TX_CLK (20%–80%)	t _{RMTR}	1.0	—	5.0	ns
Fall time TSEC _n _TX_CLK (80%–20%)	t _{RMTF}	1.0	—	5.0	ns
TSEC _n _TX_CLK to RMII data TXD[1:0], TX_EN delay	t _{RMTDX}	2.0	—	10.0	ns

This figure shows the RMII transmit AC timing diagram.

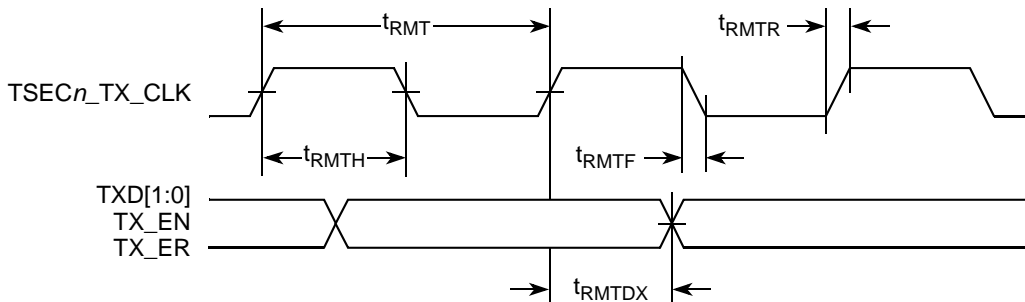

Figure 15. RMII transmit AC timing diagram

2.11.2.2 RMII receive AC timing specifications

This table lists the RMII receive AC timing specifications. In RMII mode the reference clock must be fed to TSECn_TX_CLK. The reference clock is used for both transmit and receive.

Table 33. RMII receive AC timing specifications

Parameter/Condition	Symbol	Min	Typ	Max	Unit
TSECn_TX_CLK clock period	t_{RMR}	—	20.0	—	ns
TSECn_TX_CLK duty cycle	t_{RMRH}	35	—	65	%
TSECn_TX_CLK peak-to-peak jitter	t_{RMRJ}	—	—	250	ps
Rise time TSECn_TX_CLK (20%–80%)	t_{RMRR}	1.0	—	5.0	ns
Fall time TSECn_TX_CLK (80%–20%)	t_{RMRF}	1.0	—	5.0	ns
RXD[1:0], CRS_DV, RX_ER setup time to TSECn_TX_CLK rising edge	t_{RMRDV}	4.0	—	—	ns
RXD[1:0], CRS_DV, RX_ER hold time to TSECn_TX_CLK rising edge	t_{RMRDX}	2.0	—	—	ns

This figure provides the AC test load for eTSEC.

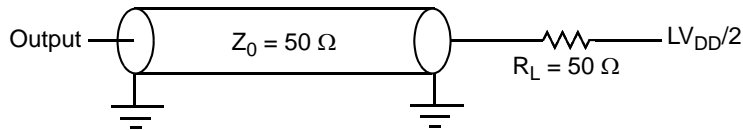

Figure 16. eTSEC AC test load

This figure shows the RMII receive AC timing diagram.

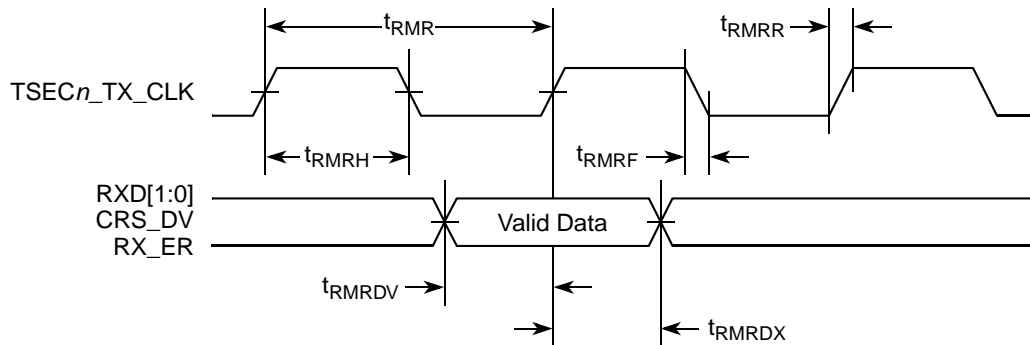

Figure 17. RMII receive AC timing diagram

2.11.2.3 RGMII AC timing specifications

This table presents the RGMII AC timing specifications.

Table 34. RGMII AC timing specification

Parameter/Condition	Symbol ¹	Min	Typ	Max	Unit	Note
Data to clock output skew (at transmitter)	t_{SKRGT_TX}	-500	0	500	ps	5
Data to clock input skew (at receiver)	t_{SKRGT_RX}	1.0	—	2.8	ns	2
Clock period duration	t_{RGT}	7.2	8.0	8.8	ns	3

Table 34. RGMII AC timing specification (continued)

Parameter/Condition	Symbol ¹	Min	Typ	Max	Unit	Note
Duty cycle for 10BASE-T and 100BASE-TX	t_{RGTH}/t_{RGT}	40	50	60	%	3, 4
Duty cycle for Gigabit	t_{RGTH}/t_{RGT}	45	50	55	%	—
Rise time (20%–80%)	t_{RGTR}	—	—	0.75	ns	—
Fall time (20%–80%)	t_{RGTF}	—	—	0.75	ns	—

Note:

- In general, the clock reference symbol representation for this section is based on the symbols RGT to represent RGMII timing. For example, the subscript of t_{RGT} represents the receive (RX) clock. Note also that the notation for rise (R) and fall (F) times follows the clock symbol that is being represented. For symbols representing skews, the subscript is skew (SK) followed by the clock that is being skewed (RGT).
- This implies that PC board design requires clocks to be routed such that an additional trace delay of greater than 1.5 ns is added to the associated clock signal. Many PHY vendors already incorporate the necessary delay inside their chip. If so, additional PCB delay is probably not needed.
- For 10 and 100 Mbps, t_{RGT} scales to 400 ns \pm 40 ns and 40 ns \pm 4 ns, respectively.
- Duty cycle may be stretched/shrunk during speed changes or while transitioning to a received packet's clock domains as long as the minimum duty cycle is not violated and stretching occurs for no more than three t_{RGT} of the lowest speed transitioned between.
- The frequency of RX_CLK should not exceed the frequency of GTX_CLK125 by more than 300 ppm.

This figure shows the RGMII AC timing and multiplexing diagrams.

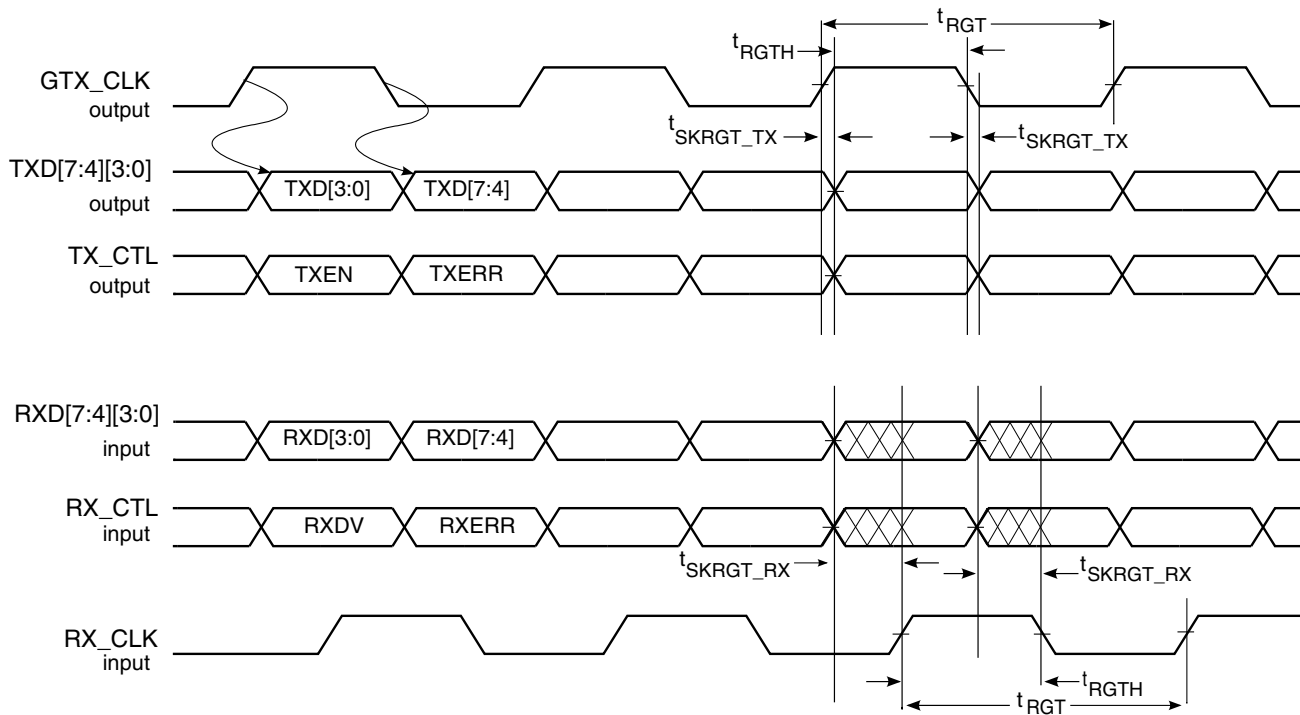

Figure 18. RGMII AC Timing and Multiplexing Diagrams

WARNING

Freescale guarantees timings generated from the MAC. Board designers must ensure delays needed at the PHY or the MAC.

2.11.3 MII management DC electrical characteristics

The MDC and MDIO are defined to operate at a supply voltage of 3.3 V. The DC electrical characteristics for MDIO and MDC are provided in this table.

Table 35. MII Management DC electrical characteristics (LV_{DD} = 3.3V)

Parameter	Symbol	Min	Max	Unit	Note
Input high voltage	V _{IH}	2.0	—	V	1
Input low voltage	V _{IL}	—	0.90	V	1
Input high current (LV _{DD} = Max, V _{IN} = 2.1 V)	I _{IH}	—	40	μA	2
Input low current (LV _{DD} = Max, V _{IN} = 0.5 V)	I _{IL}	-600	—	μA	—
Output high voltage (LV _{DD} = Min, I _{OH} = -1.0 mA)	V _{OH}	2.10	—	V	—
Output low voltage (LV _{DD} = Min, I _{OL} = 1.0 mA)	V _{OL}	—	0.50	V	—

Note:

1. The min V_{IL} and max V_{IH} values are based on the respective min and max LV_{IN} values found in [Table 3](#).
2. The symbol V_{IN}, in this case, represents the LV_{IN} symbol referenced in [Table 2](#).

The MDC and MDIO are defined to operate at a supply voltage of 2.5 V. The DC electrical characteristics for MDIO and MDC are provided in this table.

Table 36. MII management DC electrical characteristics (LV_{DD} = 2.5V)

Parameters	Symbol	Min	Max	Unit	Note
Input high voltage	V _{IH}	1.70	—	V	1
Input low voltage	V _{IL}	—	0.70	V	1
Input high current (V _{IN} = LV _{DD})	I _{IH}	—	10	μA	2
Input low current (V _{IN} = GND)	I _{IL}	-15	—	μA	—
Output high voltage (LV _{DD} = Min, I _{OH} = -1.0 mA)	V _{OH}	2.00	—	V	—
Output low voltage (LV _{DD} = Min, I _{OL} = 1.0 mA)	V _{OL}	—	0.40	V	—

Note:

1. The min V_{IL} and max V_{IH} values are based on the respective min and max LV_{IN} values found in [Table 3](#).
2. The symbol V_{IN}, in this case, represents the LV_{IN} symbol referenced in [Table 2](#).

2.11.4 MII management AC electrical specifications

This table provides the MII management AC timing specifications.

Table 37. MII management AC timing specifications

At recommended operating conditions with V_{DD} is $3.3\text{ V} \pm 5\%$.

Parameter/Condition	Symbol ¹	Min	Typ	Max	Unit	Note
MDC frequency	f_{MDC}	—	2.5	—	MHz	2
MDC period	t_{MDC}	—	400	—	ns	—
MDC clock pulse width high	t_{MDCH}	32	—	—	ns	—
MDC to MDIO delay	t_{MDKHDX}	$(16 \times t_{plb_clk}) - 3$	—	$(16 \times t_{plb_clk}) + 3$	ns	3, 4
MDIO to MDC setup time	t_{MDDVKH}	6	—	—	ns	—
MDIO to MDC hold time	t_{MDDXKH}	0	—	—	ns	—
MDC rise time	t_{MDCR}	—	—	10	ns	—
MDC fall time	t_{MDHF}	—	—	10	ns	—

Note:

- The symbols used for timing specifications follow the pattern of $t_{(\text{first two letters of functional block})(\text{signal})(\text{state})(\text{reference})(\text{state})}$ for inputs and $t_{(\text{first two letters of functional block})(\text{reference})(\text{state})(\text{signal})(\text{state})}$ for outputs. For example, t_{MDKHDX} symbolizes management data timing (MD) for the time t_{MDC} from clock reference (K) high (H) until data outputs (D) are invalid (X) or data hold time. Also, t_{MDDVKH} symbolizes management data timing (MD) with respect to the time data input signals (D) reach the valid state (V) relative to the t_{MDC} clock reference (K) going to the high (H) state or setup time. For rise and fall times, the latter convention is used with the appropriate letter: R (rise) or F (fall).
- This parameter is dependent on the platform clock frequency (MIIMCFG [MgmtClk] field determines the clock frequency of the MgmtClk Clock EC_MDC).
- This parameter is dependent on the platform clock frequency. The delay is equal to 16 platform clock periods ± 3 ns. For example, with a platform clock of 333 MHz, the min/max delay is $48\text{ ns} \pm 3\text{ ns}$. Similarly, if the platform clock is 400 MHz, the min/max delay is $40\text{ ns} \pm 3\text{ ns}$.
- t_{plb_clk} is the platform (CCB) clock.

This figure shows the MII management interface timing diagram.

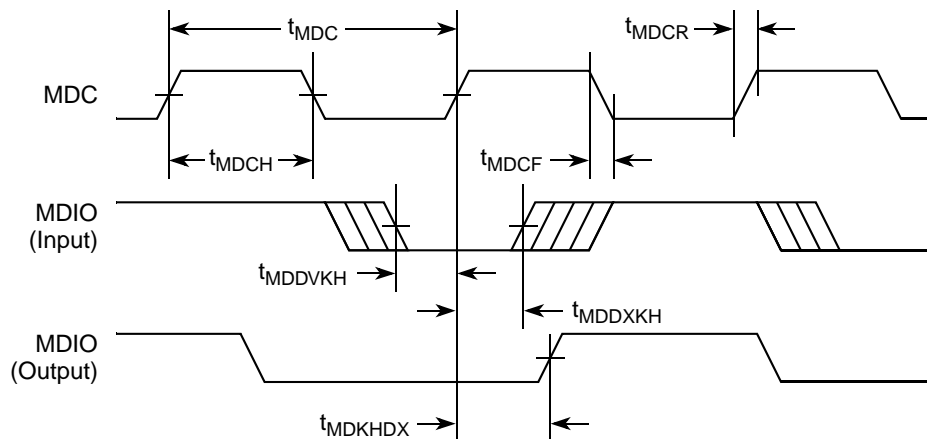
**Figure 19. MII management interface timing Diagram**

2.11.5 eTSEC IEEE Std 1588™ timing specifications

Table 38 provides the IEEE 1588 AC timing specifications.

This figure shows the data and command output AC timing diagram.

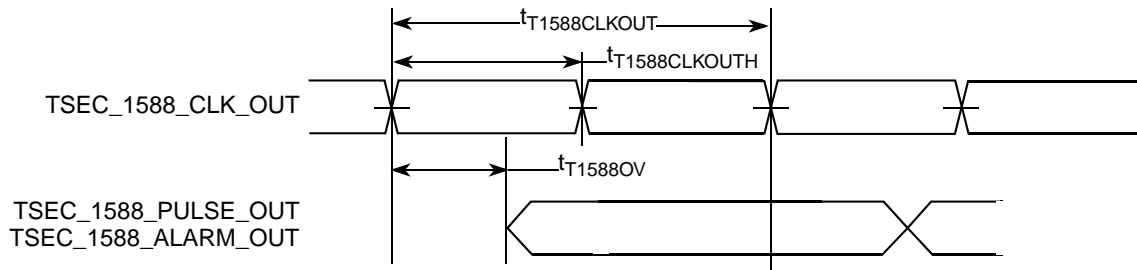

Note: The output delay is counted starting at the rising edge if $t_{T1588CLKOUT}$ is noninverting. Otherwise, it is counted starting at the falling edge.

Figure 20. eTSEC IEEE 1588 output AC timing

This figure shows the data and command input AC timing diagram.

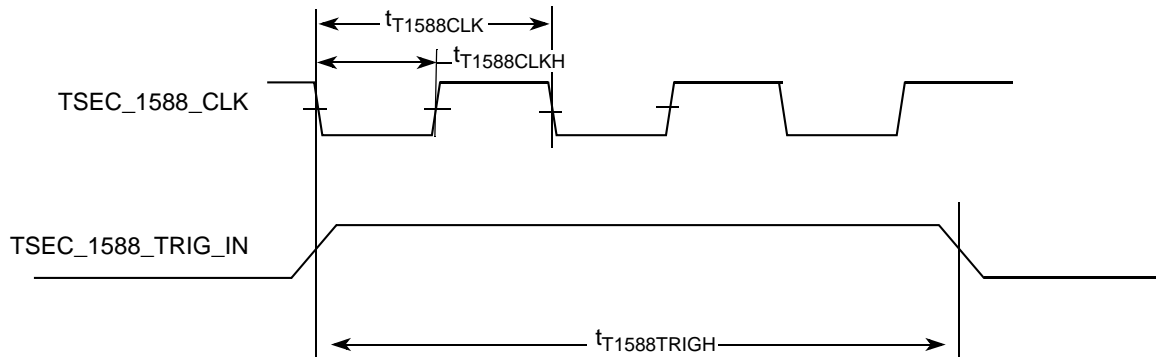

Figure 21. eTSEC IEEE 1588 input AC timing

2.11.5.1 eTSEC IEEE Std 1588 AC electrical characteristics

This table provides the IEEE 1588 AC timing specifications.

Table 38. eTSEC IEEE 1588 AC timing specifications

Parameter/Condition	Symbol	Min	Typ	Max	Unit	Note
TSEC_1588_CLK clock period	$t_{T1588CLK}$	3.3	—	$T_{RX_CLK} \times 7$	ns	1, 2, 3, 4
TSEC_1588_CLK duty cycle	$t_{T1588CLKH}/t_{T1588CLK}$	40	50	60	%	—
TSEC_1588_CLK peak-to-peak jitter	$t_{T1588CLKINJ}$	—	—	250	ps	—
Rise time eTSEC_1588_CLK (20%–80%)	$t_{T1588CLKINR}$	1.0	—	2.0	ns	—
Fall time eTSEC_1588_CLK (80%–20%)	$t_{T1588CLKINF}$	1.0	—	2.0	ns	—
TSEC_1588_CLK_OUT clock period	$t_{T1588CLKOUT}$	$2 \times t_{T1588CLK}$	—	—	ns	—
TSEC_1588_CLK_OUT duty cycle	$t_{T1588CLKOTH}/t_{T1588CLKOUT}$	30	50	70	%	—

Table 38. eTSEC IEEE 1588 AC timing specifications (continued)

Parameter/Condition	Symbol	Min	Typ	Max	Unit	Note
TSEC_1588_PULSE_OUT, TSEC_1588_ALARM_OUT	$t_{T1588OV}$	0.5	—	3.0	ns	—
TSEC_1588_TRIG_IN pulse width	$t_{T1588TRIGH}$	$2 \times t_{T1588CLK_MAX}$	—	—	ns	2

Note:

- T_{RX_CLK} is the maximum clock period of eTSEC receiving clock selected by TMR_CTRL[CKSEL]. See the P1022 QorIQ Integrated Processor Reference Manual, for a description of TMR_CTRL registers.
- It needs to be at least two times the clock period of the clock selected by TMR_CTRL[CKSEL]. See the P1022 QorIQ Integrated Processor Reference Manual, for a description of TMR_CTRL registers.
- The maximum value of $t_{T1588CLK}$ is not only defined by the value of T_{RX_CLK} , but also defined by the recovered clock. For example, for 10/100/1000 Mbps modes, the maximum value of $t_{T1588CLK}$ is 2800, 280, and 56 ns, respectively.
- It needs to be greater than half of the platform (CCB) clock period. This places a higher minimum value of the $t_{T1588CLK}$ when operating at higher platform frequencies.

2.11.5.2 eTSEC IEEE Std 1588 DC electrical characteristics

This table shows eTSEC IEEE Std 1588 DC electrical characteristics when operating at $LV_{DD} = 3.3$ V supply.

Table 39. eTSEC IEEE 1588 DC electrical characteristics ($LV_{DD} = 3.3$ V)

For recommended operating conditions with $LV_{DD} = 3.3$ V.

Parameter	Symbol	Min	Max	Unit	Note
Input high voltage	V_{IH}	2.0	—	V	2
Input low voltage	V_{IL}	—	0.9	V	2
Input high current ($LV_{DD} = \text{Max}$, $V_{IN} = 2.1$ V)	I_{IH}	—	40	μA	1
Input low current ($LV_{DD} = \text{Max}$, $V_{IN} = 0.5$ V)	I_{IL}	-600	—	μA	1
Output high voltage ($LV_{DD} = \text{Min}$, $I_{OH} = -1.0$ mA)	V_{OH}	2.4	—	V	—
Output low voltage ($LV_{DD} = \text{Min}$, $I_{OL} = 1.0$ mA)	V_{OL}	—	0.4	V	—

Note:

- Note that the symbol V_{IN} , in this case, represents the LV_{IN} symbol referenced in Table 2 and Table 3.
- The min V_{IL} and max V_{IH} values are based on the respective LV_{IN} values found in Table 3.

This table shows the IEEE 1588 DC electrical characteristics when operating at $LV_{DD} = 2.5$ V supply.

Table 40. eTSEC IEEE 1588 DC electrical characteristics ($LV_{DD} = 2.5$ V)

For recommended operating conditions with $LV_{DD} = 2.5$ V

Parameter	Symbol	Min	Max	Unit	Note
Input high voltage	V_{IH}	1.70	—	V	—
Input low voltage	V_{IL}	—	0.70	V	—
Input current ($LV_{IN} = 0$ V or $LV_{IN} = LV_{DD}$)	I_{IH}	—	± 40	μA	2
Output high voltage ($LV_{DD} = \text{min}$, $I_{OH} = -1.0$ mA)	V_{OH}	2.00	—	V	—
Output low voltage ($LV_{DD} = \text{min}$, $I_{OL} = 1.0$ mA)	V_{OL}	—	0.40	V	—

Electrical characteristics

Table 40. eTSEC IEEE 1588 DC electrical characteristics (LV_{DD} = 2.5 V) (continued)

For recommended operating conditions with LV_{DD} = 2.5 V

Parameter	Symbol	Min	Max	Unit	Note
-----------	--------	-----	-----	------	------

Note:

1. The min V_{IL} and max V_{IH} values are based on the respective min and max LV_{IN} values found in [Table 3](#).
2. The symbol V_{IN}, in this case, represents the LV_{IN} symbols referenced in [Table 2](#) and [Table 3](#).

2.11.6 SGMII interface electrical characteristics

Each SGMII port features a 4-wire AC-Coupled serial link from the SerDes interface of the P1013, as shown in [Figure 22](#), where C_{TX} is the external (on board) AC-Coupled capacitor. Each output pin of the SerDes transmitter differential pair features 50-Ω output impedance. Each input of the SerDes receiver differential pair features 50-Ω on-die termination to the ground. The reference circuit of the SerDes transmitter and receiver is shown in [Figure 50](#).

2.11.6.1 DC requirements for SGMII SD_n_REF_CLK and $\overline{\text{SD}}_n\text{_REF_CLK}$

The characteristics and DC requirements of the separate SerDes reference clock are described in [Section 2.21.3](#), “DC level requirement for SerDes reference clocks.”

2.11.6.2 AC requirements for SGMII SD_n_REF_CLK and $\overline{\text{SD}}_n\text{_REF_CLK}$

Note that the SGMII clock requirements for SD_n_REF_CLK and $\overline{\text{SD}}_n\text{_REF_CLK}$ are intended to be used within the clocking guidelines specified by [Section 2.21.3.1](#), “AC requirements for SerDes reference clocks.”

2.11.6.3 SGMII transmitter electrical characteristics

This section contains the following subsections:

- [Section 2.11.6.3.1](#), “SGMII transmit DC timing specifications”
- [Section 2.11.6.3.2](#), “SGMII transmit AC timing specifications”

2.11.6.3.1 SGMII transmit DC timing specifications

[Table 41](#) and [Table 43](#) describe the SGMII SerDes transmitter and receiver AC-Coupled DC electrical characteristics.

Transmitter DC characteristics are measured at the transmitter outputs (SD_n_TX[n] and $\overline{\text{SD}}_n\text{_TX}[n]$) as shown in [Figure 23](#).

Table 41. SGMII DC transmitter electrical characteristics

Parameter	Symbol	Min	Typ	Max	Unit	Note
Output high voltage	V _{OH}	—	—	XV _{DD} -Typ/2 + V _{OD} -max/2	mV	1
Output low voltage	V _{OL}	XV _{DD} -Typ/2 – V _{OD} -max/2	—	—	mV	1

Table 41. SGMII DC transmitter electrical characteristics (continued)

Parameter	Symbol	Min	Typ	Max	Unit	Note
Output differential voltage ^{2, 3, 4} (XV_{DD-Typ} at 1.0V)	$ V_{OD} $	320	500	725	mV	Equalization setting: 1.0x.
		294	459	665		Equalization setting: 1.09x
		267	417	604		Equalization setting: 1.2x
		241	376	545		Equalization setting: 1.33x
		213	333	483		Equalization setting: 1.5x
		187	292	424		Equalization setting: 1.71x
		160	250	362		Equalization setting: 2.0x
Output impedance (single-ended)	R_O	40	50	60	Ω	—

Note:

- This does not align to DC-coupled SGMII.
- $|V_{OD}| = |V_{SDn_TXn} - V_{SDn_TXn}|$. $|V_{OD}|$ is also referred to as output differential peak voltage. $V_{TX-DIFFp-p} = 2 * |V_{OD}|$.
- The $|V_{OD}|$ value shown in the table assumes the following transmit equalization setting in the TXEQ0, TXEQ1 (for SerDes lanes 0 and 1) or TXEQ2, TXEQ3 (for SerDes lanes 2 and 3) bit field of P1013SerDes 0,1control register:
 - The above bit field is set based on the equalization setting shown in table.
- The $|V_{OD}|$ value shown in the Typ column is based on the condition of $XV_{DD-Typ} = 1.0V$, no common mode offset variation, SerDes transmitter is terminated with 100- Ω differential load between $SD_TX[n]$ and $SD_TX[\bar{n}]$.

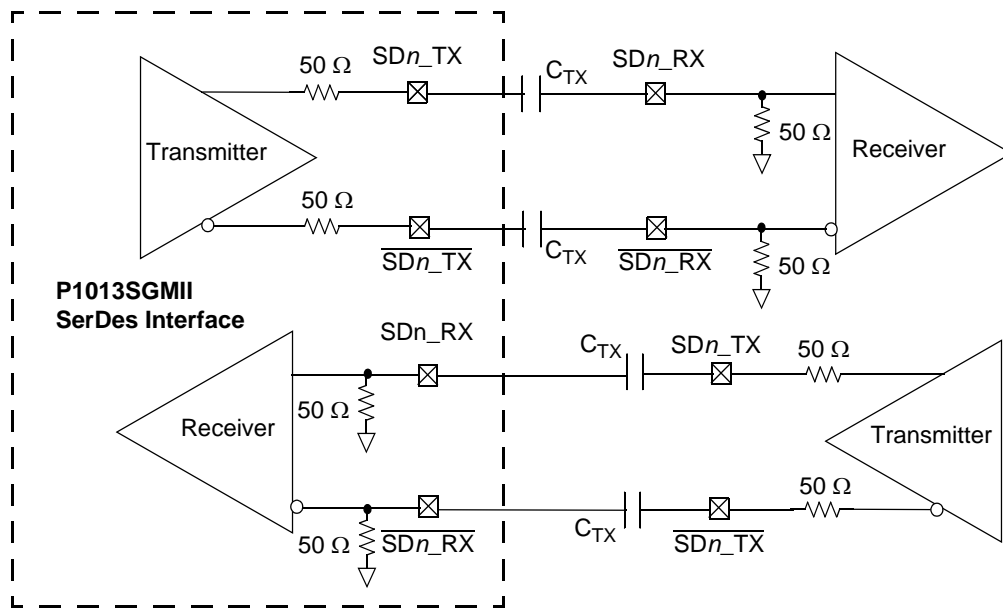

Figure 22. 4-Wire AC-coupled SGMII serial link connection example

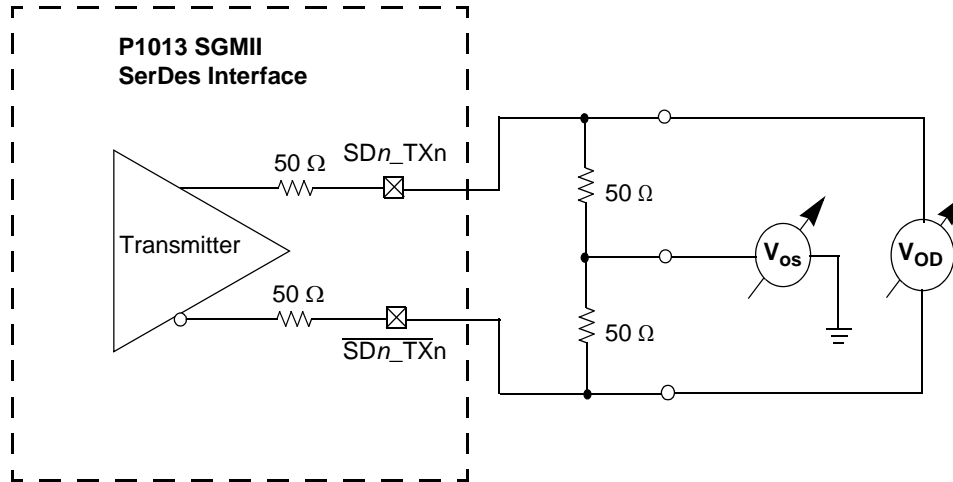

Figure 23. SGMII transmitter DC measurement circuit

2.11.6.3.2 SGMII transmit AC timing specifications

This table provides the SGMII transmit AC timing specifications. A source synchronous clock is not supported. The AC timing specifications do not include RefClk jitter.

Table 42. SGMII transmit AC timing specifications

At recommended operating conditions with $XV_{DD} = 1.0 \text{ V} \pm 5\%$.

Parameter	Symbol	Min	Typ	Max	Unit	Note
Deterministic Jitter	JD	—	—	0.17	UI p-p	—
Total Jitter	JT	—	—	0.35	UI p-p	2
Unit Interval	UI	799.92	800	800.08	ps	1
AC coupling capacitor	C_{TX}	10	—	200	nF	3

Note:

1. Each UI is $800 \text{ ps} \pm 100 \text{ ppm}$.
2. See Figure 25 for single frequency sinusoidal jitter limits.
3. The external AC coupling capacitor is required. It is recommended that it be placed near the device transmitter outputs.

2.11.6.4 SGMII AC measurement details

Transmitter and receiver AC characteristics are measured at the transmitter outputs ($SD_TX[n]$ and $\overline{SD_TX}[n]$) or at the receiver inputs ($SD_RX[n]$ and $\overline{SD_RX}[n]$) as depicted in this figure, respectively.

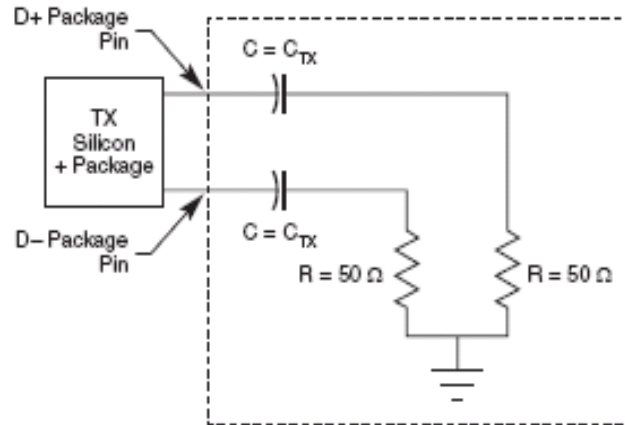

Figure 24. SGMII AC test/measurement Load

2.11.7 SGMII receiver timing specifications

Table 43 and Table 44 provide the SGMII receive DC and AC timing specifications. Source synchronous clocking is not supported. Clock is recovered from the data.

2.11.7.1 SGMII DC receiver timing specification

This table lists the SGMII DC receiver electrical characteristics.

Table 43. SGMII DC receiver electrical characteristics⁵

Parameter	Symbol	Min	Typ	Max	Unit	Note	
DC Input voltage range	—	N/A			—	1	
Input differential voltage	LSTS = 001	$V_{RX_DIFFp-p}$	100	—	1200	mV	2, 4
	LSTS = 100		175	—			
Loss of signal threshold	LSTS = 001	VLOS	30	—	100	mV	3, 4
	LSTS = 100		65	—	175		
Receiver differential input impedance	Z_{RX_DIFF}	80	—	120	Ω	—	

Note:

1. Input must be externally AC-coupled.
2. $V_{RX_DIFFp-p}$ is also referred to as peak-to-peak input differential voltage.
3. The concept of this parameter is equivalent to the Electrical Idle Detect Threshold parameter in PCI Express. Refer to PCI Express Differential Receiver (RX) Input Specifications section for further explanation.
4. The LSTS shown in the table refers to the EIC0[0:2] or EIC1[0:2] bit field of P1013's SerDes2 Control Register 3 and EIC2[0:2] or EIC3[0:2] bit field of P1013's SerDes1 Control Register 4
5. The supply voltage is 1.0 V.

2.11.7.2 SGMII receiver AC timing specification

This table provides the SGMII receiver AC timing specifications. The AC timing specifications do not include RefClk jitter. Source synchronous clocking is not supported. Clock is recovered from the data.

Table 44. SGMII receive AC timing specifications

At recommended operating conditions with $SV_{DD} = 1.0\text{ V} \pm 5\%$.

Parameter	Symbol	Min	Typ	Max	Unit	Note
Deterministic Jitter Tolerance	JD	0.37	—	—	UI p-p	1, 3
Combined Deterministic and Random Jitter Tolerance	JDR	0.55	—	—	UI p-p	1, 3
Total Jitter Tolerance	JT	0.65	—	—	UI p-p	1,3
Bit Error Ratio	BER	—	—	10^{-12}	—	—
Unit Interval	UI	799.92	800.00	800.08	ps	2

Note:

1. Measured at receiver.
2. Each UI is $800\text{ ps} \pm 100\text{ ppm}$.
3. Refer to RapidIO™ 1x/4x LP Serial Physical Layer Specification for interpretation of jitter specifications.

The sinusoidal jitter in the total jitter tolerance may have any amplitude and frequency in the unshaded region of this figure.

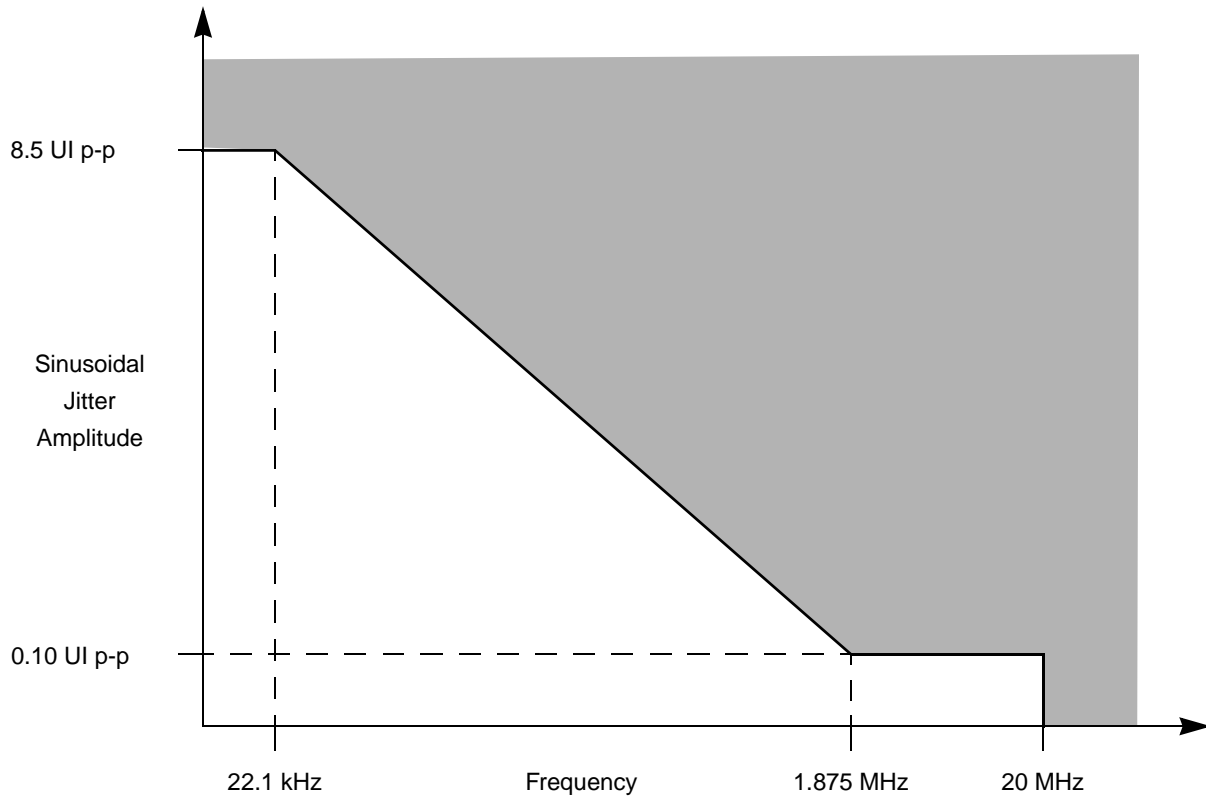

Figure 25. Single frequency sinusoidal jitter limits

2.12 USB

This section provides the AC and DC electrical specifications for the USB interfaces of the device.

This table provides the DC electrical characteristics for the ULPI interface when operating at 3.3 V.

Table 45. USB DC electrical characteristics (3.3 V)

For recommended operating conditions refer to [Table 3](#).

Parameter	Symbol	Min	Max	Unit	Note
Input high voltage	V_{IH}	2	—	V	1
Input low voltage	V_{IL}	—	0.8	V	1
Input current ($V_{IN} = 0$ V or $V_{IN} = OV_{DD}$)	I_{IN}	—	± 40	μ A	2
Output high voltage ($LV_{DD} = \text{min}$, $I_{OH} = -2$ mA)	V_{OH}	2.8	—	V	—
Output low voltage ($LV_{DD} = \text{min}$, $I_{OL} = 2$ mA)	V_{OL}	—	0.3	V	—

Note:

1. The min V_{IL} and max V_{IH} values are based on the respective min and max LV_{IN} values found in [Table 3](#).
2. The symbol LV_{IN} represents the input voltage of the supply, and is referenced in [Table 3](#).

This table provides the DC electrical characteristics for the ULPI interface when operating at 2.5 V.

Table 46. USB DC electrical characteristics (2.5 V)

For recommended operating conditions, see [Table 3](#).

Parameter	Symbol	Min	Max	Unit	Note
Input high voltage	V_{IH}	1.7	—	V	1
Input low voltage	V_{IL}	—	0.7	V	1
Input current ($V_{IN} = 0$ V or $V_{IN} = LV_{DD}$)	I_{IN}	—	± 40	μ A	2
Output high voltage ($LV_{DD} = \text{min}$, $I_{OH} = -1$ mA)	V_{OH}	2.0	—	V	—
Output low voltage ($OV_{DD} = \text{min}$, $I_{OL} = 1$ mA)	V_{OL}	—	0.4	V	—

Note:

1. The min V_{IL} and max V_{IH} values are based on the respective min and max LV_{IN} values found in [Table 3](#).
2. The symbol LV_{IN} represents the input voltage of the supply, and is referenced in [Table 3](#).

2.12.1 USB AC electrical specifications

This table describes the general timing parameters of the USB interface of the device.

Table 47. USB general timing parameters

Parameter	Symbol	Min	Max	Unit	Note
USB clock cycle time	t_{USCK}	15	—	ns	2, 3, 4, 5
Input setup to USB clock—all inputs	t_{USIVKH}	4	—	ns	2, 3, 4, 5
input hold to USB clock—all inputs	t_{USIXKH}	1	—	ns	2, 3, 4, 5
USB clock to output valid—all outputs	t_{USKHOV}	—	7	ns	2, 3, 4, 5
Output hold from USB clock—all outputs	t_{USKHOX}	2	—	ns	2, 3, 4, 5

Table 47. USB general timing parameters (continued)

Parameter	Symbol	Min	Max	Unit	Note
-----------	--------	-----	-----	------	------

Note:

1. The symbols for timing specifications follow the pattern of $t_{(First\ two\ letters\ of\ functional\ block)(signal)(state)\ (reference)(state)}$ for inputs and $t_{(First\ two\ letters\ of\ functional\ block)(reference)(state)(signal)(state)}$ for outputs. For example, t_{USIXKH} symbolizes USB timing (US) for the input (I) to go invalid (X) with respect to the time the USB clock reference (K) goes high (H). Also, t_{USKHGX} symbolizes USB timing (US) for the USB clock reference (K) to go high (H) with respect to the output (O) going invalid (X) or output hold time.
2. All timings are in reference to USB clock.
3. All signals are measured from $LV_{DD}/2$ of the rising edge of the USB clock to $0.4 \times LV_{DD}$ of the signal in question for 3.3 V signaling levels.
4. Input timings are measured at the pin.
5. For active/float timing measurements, the Hi-Z or off state is defined to be when the total current delivered through the component pin is less than or equal to that of the leakage current specification.
6. When switching the data pins from outputs to inputs using the USBn_DIR pin, the output timings is violated on that cycle because the output buffers are tristated asynchronously. This must not be a problem, because the PHY must not be functionally looking at these signals on that cycle as per ULPI specifications.

The following two figures provide the AC test load and signals for the USB.

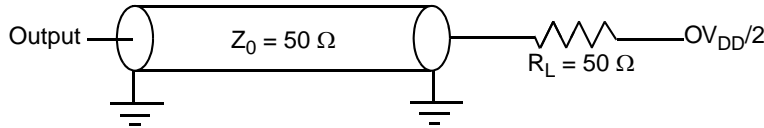

Figure 26. USB AC test load

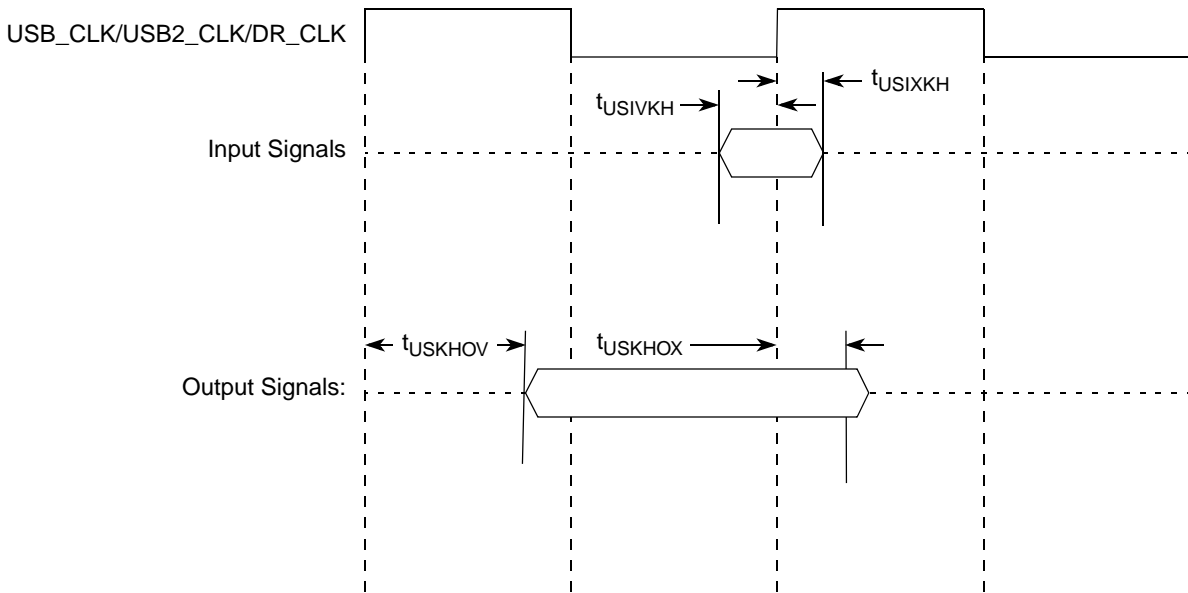

Figure 27. USB signals

This table provides the USB clock input (USB_CLK_IN) AC timing specifications.

Table 48. USB_CLK_IN AC timing specifications

Parameter	Condition	Symbol	Min	Typ	Max	Unit
Frequency range	Steady state	$f_{\text{USB_CLK_IN}}$	59.97	60	60.03	MHz
Clock frequency tolerance	—	$t_{\text{CLK_TOL}}$	-0.05	0	0.05	%
Reference clock duty cycle	Measured at 1.6 V	$t_{\text{CLK_DUTY}}$	40	50	60	%
Total input jitter/time interval error	Peak-to-peak value measured with a second-order, high-pass filter of 500 kHz bandwidth	$t_{\text{CLK_PJ}}$	—	—	200	ps

2.13 Enhanced local bus interface

This section describes the DC and AC electrical specifications for the eLBC interface of the device.

2.13.1 Enhanced local bus DC electrical specifications

This table provides the DC electrical characteristics for the eLBC interface operating at $BV_{\text{DD}} = 3.3 \text{ V DC}$.

Table 49. Enhanced local bus DC electrical specifications (3.3 V DC)

Parameter	Symbol	Min	Max	Unit
High-level input voltage	V_{IH}	2	—	V
Low-level input voltage	V_{IL}	—	0.8	V
Input current ($V_{\text{IN}} = 0 \text{ V}$ or $V_{\text{IN}} = BV_{\text{DD}}$)	I_{IN}	—	± 40	μA
High-level output voltage ($BV_{\text{DD}} = \text{min}$, $I_{\text{OH}} = -2 \text{ mA}$)	V_{OH}	2.4	—	V
Low-level output voltage ($BV_{\text{DD}} = \text{min}$, $I_{\text{OL}} = 2 \text{ mA}$)	V_{OL}	—	0.4	V

This table provides the DC electrical characteristics for the eLBC interface operating at $BV_{\text{DD}} = 2.5 \text{ V DC}$.

Table 50. Enhanced local bus DC electrical specifications (2.5 V DC)

Parameter	Symbol	Min	Max	Unit
High-level input voltage	V_{IH}	1.7	—	V
Low-level input voltage	V_{IL}	—	0.7	V
Input current ($V_{\text{IN}} = 0 \text{ V}$ or $V_{\text{IN}} = BV_{\text{DD}}$)	I_{IN}	—	± 40	μA
High-level output voltage ($BV_{\text{DD}} = \text{min}$, $I_{\text{OH}} = -1 \text{ mA}$)	V_{OH}	2.0	—	V
Low-level output voltage ($BV_{\text{DD}} = \text{min}$, $I_{\text{OL}} = 1 \text{ mA}$)	V_{OL}	—	0.4	V

This table provides the DC electrical characteristics for the eLBC interface operating at $BV_{\text{DD}} = 1.8 \text{ V DC}$.

Electrical characteristics

Table 51. Enhanced local bus DC electrical specifications (1.8 V DC)

Parameter	Symbol	Min	Max	Unit
High-level input voltage	V_{IH}	1.25	—	V
Low-level input voltage	V_{IL}	—	0.6	V
Input current ($V_{IN} = 0$ V or $V_{IN} = BV_{DD}$)	I_{IN}	—	± 40	μA
High-level output voltage ($BV_{DD} = \text{min}$, $I_{OH} = -0.5$ mA)	V_{OH}	1.35	—	V
Low-level output voltage ($BV_{DD} = \text{min}$, $I_{OL} = 0.5$ mA)	V_{OL}	—	0.4	V

2.13.2 Enhanced local bus AC electrical specifications

2.13.3 Test condition

This figure provides the AC test load for the enhanced local bus.

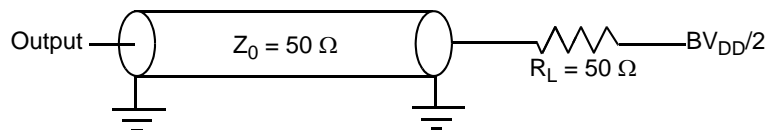

Figure 28. Enhanced local bus AC test load

2.13.4 Local bus AC electrical specification

All the output signal timings are relative to the falling edge of any LCLKs for PLL bypass mode. The external circuit must use the rising edge of the LCLKs to latch the data.

All the input timings except LGTA/LUPWAIT/LFRB are relative to the rising edge of LCLKs. LGTA/LUPWAIT/LFRB are relative to the falling edge of LCLKs.

This table describes the timing parameters of the local bus interface.

Table 52. Enhanced local bus timing parameters ($BV_{DD} = 3.3V, 2.5V$ and $1.8V$)

Parameter	Symbol	Min	Max	Unit	Note
Local bus cycle time	t_{LBK}	12	—	ns	—
Local bus duty cycle	t_{LBKH}/t_{LBK}	45	55	%	—
LCLK[n] skew to LCLK[m]	$t_{LBKSKEW}$	—	150	ps	2
Input setup (except LGTA/LUPWAIT/LFRB)	t_{LBIVKH}	6	—	ns	—
Input hold (except LGTA/LUPWAIT/LFRB)	t_{LBIXKH}	1	—	ns	—
Input setup (for LGTA/LUPWAIT/LFRB)	t_{LBIVKL}	6	—	ns	—
Input hold (for LGTA/LUPWAIT/LFRB)	t_{LBIXKL}	1	—	ns	—

Table 52. Enhanced local bus timing parameters ($BV_{DD} = 3.3V, 2.5V$ and $1.8V$) (continued)

Parameter	Symbol	Min	Max	Unit	Note
Output delay (Except LALE)	t_{LBKLOV}	—	1.5	ns	—
Output hold (Except LALE)	t_{LBKLOX}	-3.5	—	ns	5
Local bus clock to output high impedance for LAD/LDP	t_{LBKLOZ}	—	2	ns	3
LALE output negation to LAD/LDP output transition (LATCH hold time)	t_{LBONOT}	1 (LBCR[AHD] = 0)	—	eLBC controller clock	4

Note:

1. All signals are measured from $BV_{DD}/2$ of rising/falling edge of LCLK to $BV_{DD}/2$ of the signal in question
2. Skew measured between complementary signals at $BV_{DD}/2$.
3. For purposes of active/float timing measurements, the Hi-Z or off state is defined to be when the total current delivered through the component pin is less than or equal to the leakage current specification.
4. t_{LBONOT} is a measurement of the minimum time between the negation of LALE and any change in LAD. t_{LBONOT} is determined by LBCR[AHD]. The unit is the eLBC controller clock. The ratio between the platform clock and eLBC controller clock is 1:1. After power on reset, LBCR[AHD] defaults to 0, eLBC runs at maximum hold time.
5. Output hold is negative. This means that output transition happens earlier than the falling edge of LCLK.

Electrical characteristics

This figure shows the AC timing diagram.

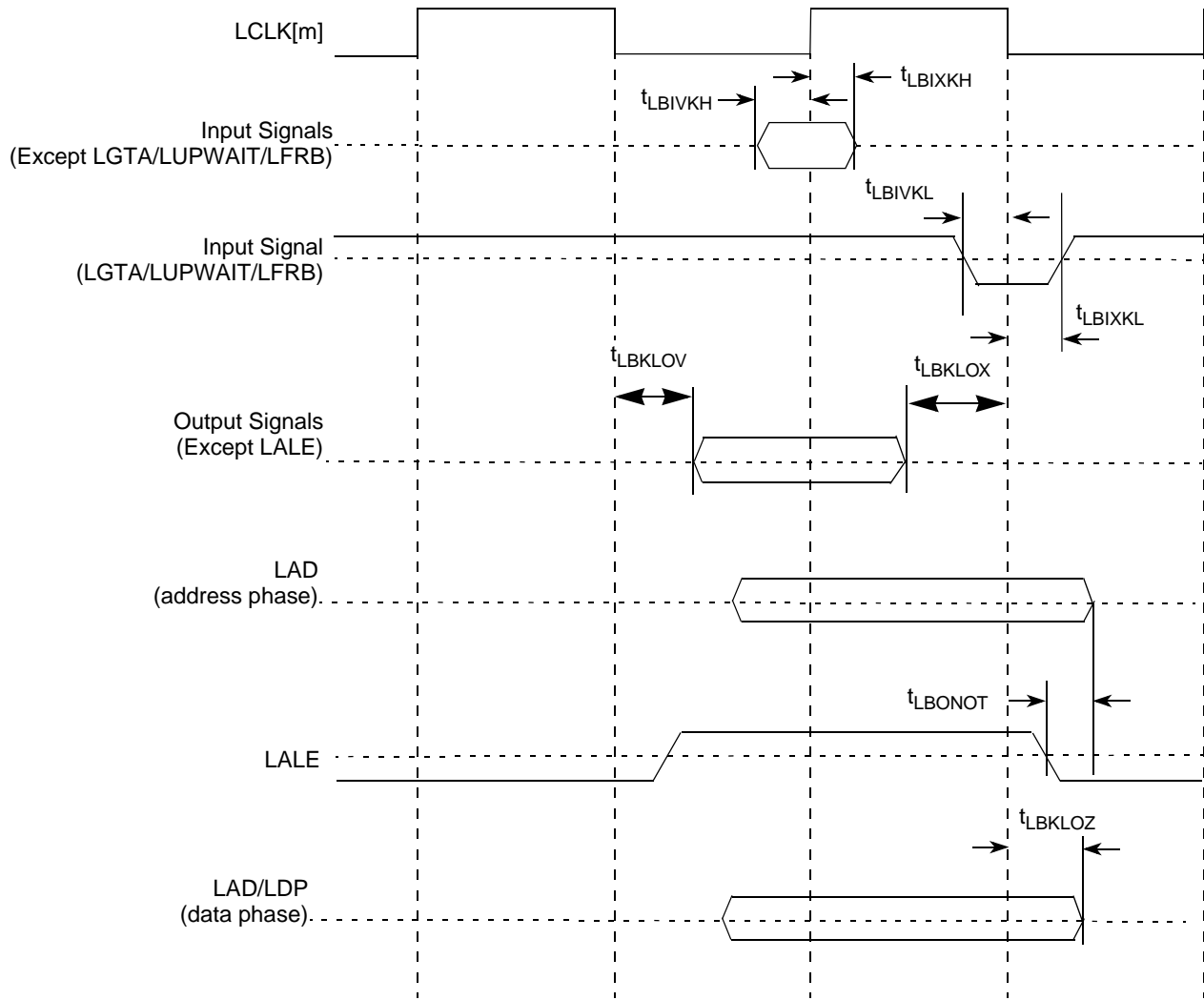

Figure 29. Enhanced local bus signals

Figure 29 AC timing diagram applies to all three controllers that eLBC supports: GPCM, UPM and FCM. For input signals, the AC timings data are used directly for all three controllers.

For output signals, each type of controller provides its own unique method to control the timing of the signals. The final signal delay value for output signals is the programmed delay plus the AC timing delay. For example, for GPCM, LCS can be programmed to delay by t_{acs} (0, 1/4, 1/2, 1, 1+1/4, 1+1/2, 2, 3 cycles), so the final delay is $t_{acs} + t_{LBKLOV}$.

This figure shows how the AC timing diagram applies to GPCM in PLL bypass mode. Same principle applies to UPM and FCM.

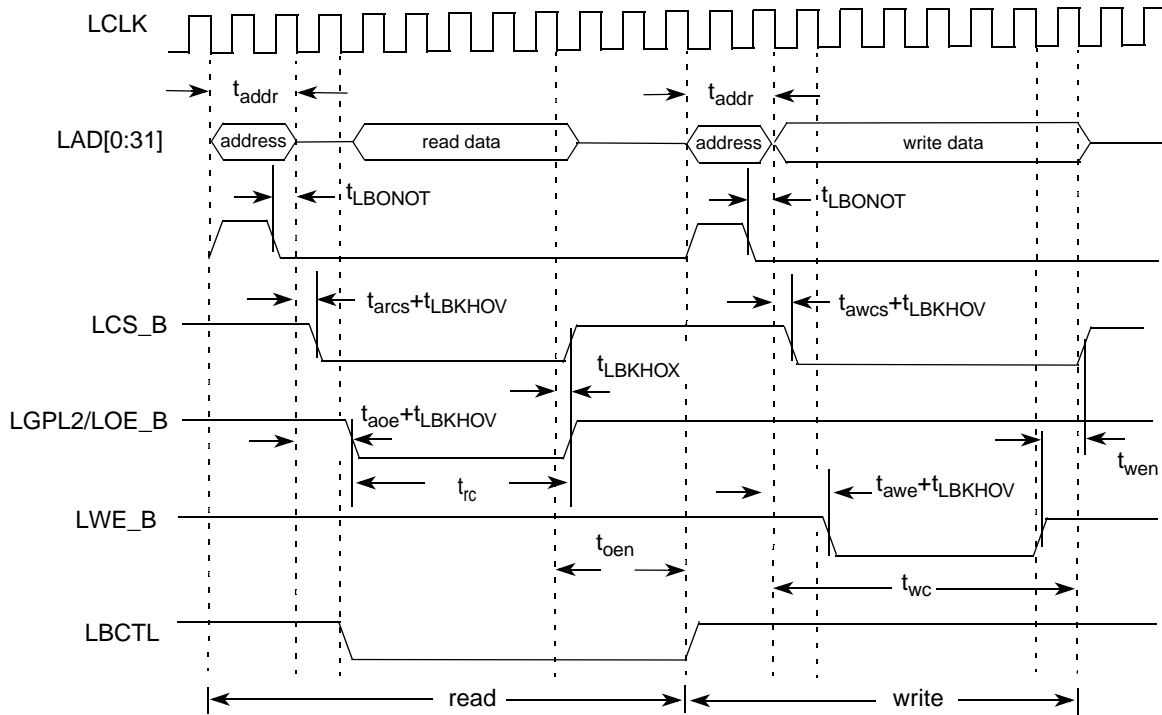

Figure 30. GPCM timing diagram

¹ t_{addr} is programmable and determined by LCRR[EADC] and ORx[EAD].

² t_{arcs} , t_{awcs} , t_{aoe} , t_{rc} , t_{oen} , t_{awe} , t_{wc} , t_{wen} are determined by ORx. See the *P1022 QorIQ Integrated Processor Reference Manual*.

2.14 Enhanced secure digital host controller (eSDHC)

This section describes the DC and AC electrical specifications for the eSDHC (SDIO) interface of the device.

2.14.1 eSDHC DC electrical characteristics

This table provides the DC electrical characteristics for the eSDHC interface of the device.

Table 53. eSDHC interface DC Electrical characteristics

Characteristic	Symbol	Condition	Min	Max	Unit	Note
Input high voltage	V_{IH}	—	$0.625 \times OV_{DD}$	—	V	1
Input low voltage	V_{IL}	—	—	$0.25 \times OV_{DD}$	V	1
Input/Output leakage current	I_{IN}/I_{OZ}	—	-50	50	μA	—

Electrical characteristics

Table 53. eSDHC interface DC Electrical characteristics (continued)

Characteristic	Symbol	Condition	Min	Max	Unit	Note
Output high voltage	V_{OH}	$I_{OH} = -100 \mu A$ @ OV_{DDmin}	$0.75 \times OV_{DD}$	—	V	—
Output low voltage	V_{OL}	$I_{OL} = 100 \mu A$ @ OV_{DDmin}	—	$0.125 \times OV_{DD}$	V	—
Output high voltage	V_{OH}	$I_{OH} = -100 \mu A$	$OV_{DD} - 0.2$	—	V	2
Output low voltage	V_{OL}	$I_{OL} = 2 \text{ mA}$	—	0.3	V	2

Note:

- Note that the min V_{IL} and max V_{IH} values are based on the respective min and max OV_{IN} values found in Figure 3.
- Open drain mode for MMC cards only.

2.14.2 eSDHC AC timing specifications

This table provides the eSDHC AC timing specifications as defined in Figure 31 and Figure 32.

Table 54. eSDHC AC timing specifications

Parameter	Symbol ¹	Min	Max	Unit	Note
SD_CLK clock frequency: SD/SDIO Full speed/high speed mode MMC Full speed/high speed mode	f_{SHSCK}	0	25/50 20/52	MHz	2, 4
SD_CLK clock low time - High speed/Full speed mode	t_{SHSCKL}	7/10	—	ns	4
SD_CLK clock high time - High speed/Full speed mode	t_{SHSCKH}	7/10	—	ns	4
SD_CLK clock rise and fall times	$t_{SHSCKR}/$ t_{SHSCKF}	—	3	ns	4
Input setup time: SD_CMD, SD_DATx, SD_CD to SD_CLK	$t_{SHSIVKH}$	5	—	ns	4
Input hold time: SD_CMD, SD_DATx, SD_CD to SD_CLK	$t_{SHSIXKH}$	2.5	—	ns	3,4
Output delay time: SD_CLK to SD_CMD, SD_DATx valid	$t_{SHSKHOV}$	-3	3	ns	4

Note:

- The symbols used for timing specifications herein follow the pattern of $t_{(\text{first three letters of functional block})(\text{signal})(\text{state})(\text{reference})(\text{state})}$ for inputs and $t_{(\text{first three letters of functional block})(\text{reference})(\text{state})(\text{signal})(\text{state})}$ for outputs. For example, $t_{FHSKHOV}$ symbolizes eSDHC high speed mode device timing (SHS) clock reference (K) going to the high (H) state, with respect to the output (O) reaching the invalid state (X) or output hold time. Note that, in general, the clock reference symbol representation is based on five letters representing the clock of a particular functional. For rise and fall times, the latter convention is used with the appropriate letter: R (rise) or F (fall).
- In full speed mode, clock frequency value can be 0 - 25 MHz for a SD/SDIO card and 0 - 20 MHz for a MMC card. In high speed mode, clock frequency value can be 0 - 50 MHz for a SD/SDIO card and 0 - 52MHz for a MMC card.
- To satisfy hold timing, the delay difference between clock input and cmd/data input must not exceed 2ns.
- $C_{CARD} \leq 10 \text{ pF}$, (1 card), and $C_L = C_{BUS} + C_{HOST} + C_{CARD} \leq 40 \text{ pF}$

This figure provides the eSDHC clock input timing diagram.

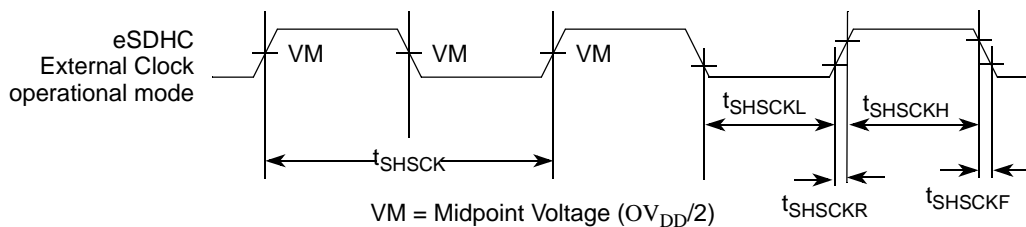

Figure 31. eSDHC clock input timing diagram

This figure provides the data and command input/output timing diagram.

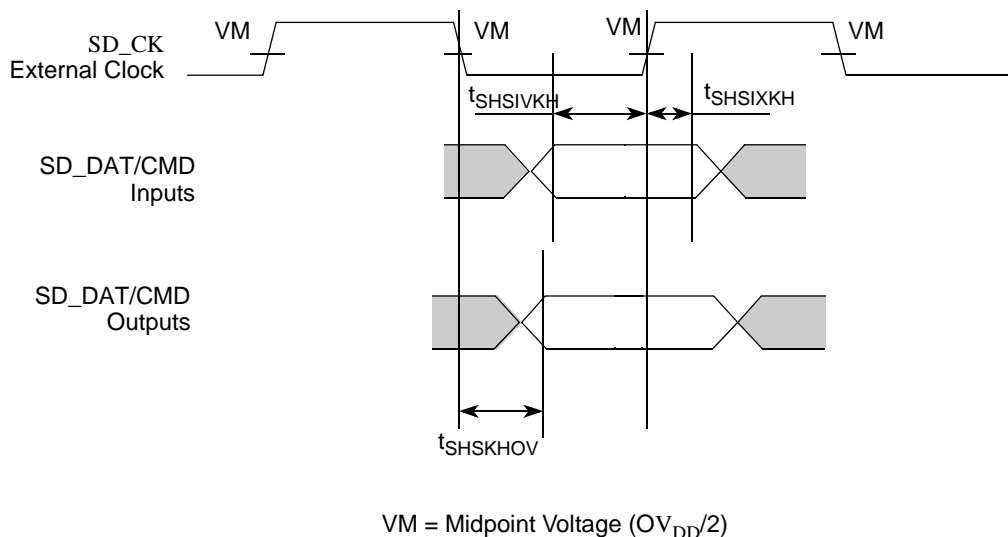

Figure 32. eSDHC data and command input/output timing diagram referenced to clock

2.15 Display interface unit

This section describes the DIU DC and AC electrical specifications.

2.15.1 DIU DC electrical characteristics

This table provides the DIU DC electrical characteristics.

Table 55. DIU DC electrical characteristics

Parameter	Symbol	Min	Max	Unit
High-level input voltage	V_{IH}	2	—	V
Low-level input voltage	V_{IL}	—	0.8	V
Input current ($V_{IN}^1 = 0$ V or $V_{IN} = BV_{DD}$)	I_{IN}	—	± 40	μ A
High-level output voltage ($BV_{DD} = \text{min}$, $I_{OH} = -100$ μ A)	V_{OH}	$BV_{DD} - 0.2$	—	V
Low-level output voltage ($BV_{DD} = \text{min}$, $I_{OL} = 100$ μ A)	V_{OL}	—	0.2	V

Note:

- The symbol V_{IN} , in this case, represents the BV_{IN} symbol referenced in [Table 2](#) and [Table 3](#).

2.15.2 DIU AC timing specifications

This figure depicts the horizontal timing (timing of one line), including both the horizontal sync pulse and the data. All parameters shown in the diagram are programmable. This timing diagram corresponds to positive polarity of the DIU_CLK_OUT signal and active-high polarity of the DIU_HSYNC, DIU_VSYNC, and DIU_DE signals. By default, all control signals and the display data are generated at the rising edge of the internal pixel clock, and the DIU_CLK_OUT output to drive the panel has the same polarity with the internal pixel clock. User can select the polarity of the DIU_HSYNC and DIU_VSYNC signal (via the SYN_POL register), whether active-high or active-low, the default is active-high. The DIU_DE signal is always active-high.

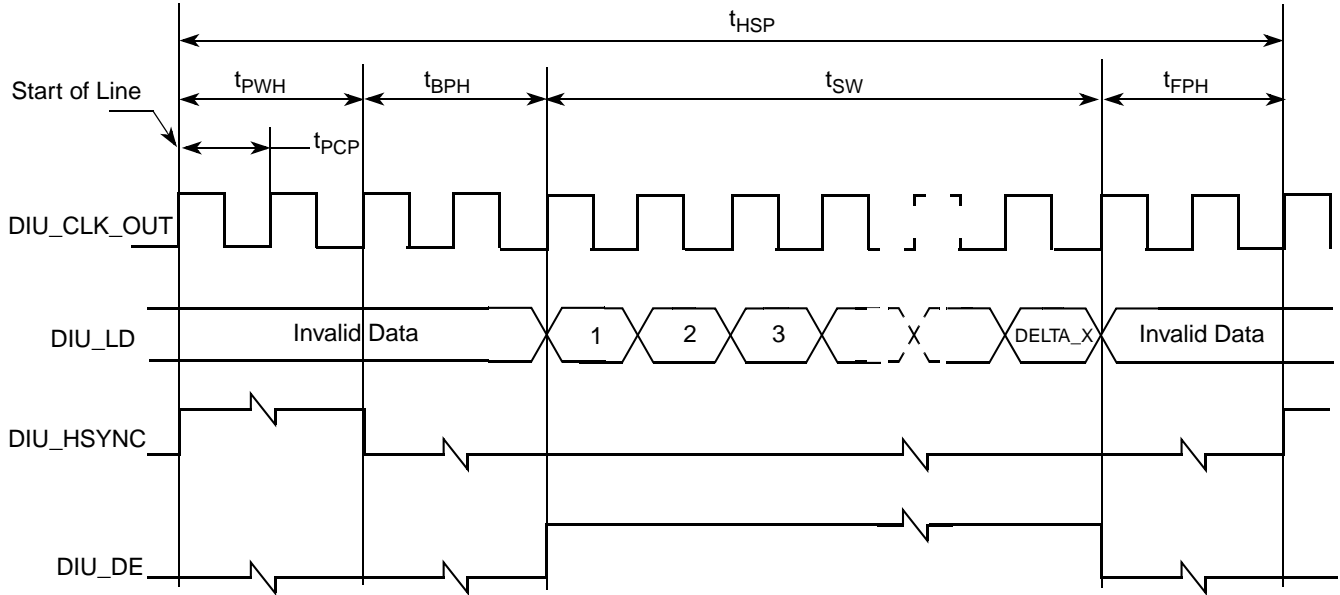

Figure 33. TFT DIU/LCD interface timing diagram—horizontal sync pulse

This figure depicts the vertical timing (timing of one frame), including both the vertical sync pulse and the data. All parameters shown in the diagram are programmable.

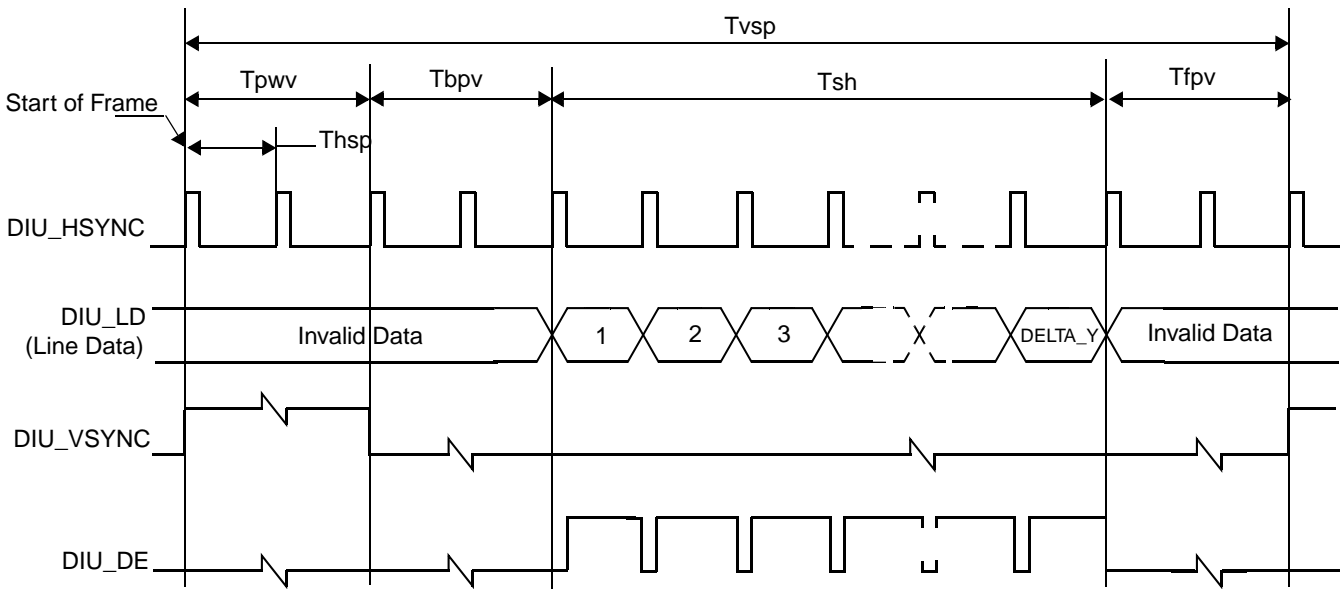

Figure 34. TFT DIU/LCD interface timing diagram—vertical sync pulse

This table shows timing parameters of signals presented in [Figure 33](#) and [Figure 34](#).

Table 56. DIU interface AC timing parameters—pixel level

Parameter	Symbol	Value	Unit	Note
Display pixel clock period	t_{PCP}	7.5 (minimum)	ns	1
—				
HSYNC width	t_{PWH}	$PW_H \times t_{PCP}$	ns	—
HSYNC back porch width	t_{BPH}	$BP_H \times t_{PCP}$	ns	—
HSYNC front porch width	t_{FPH}	$FP_H \times t_{PCP}$	ns	—
Screen width	t_{SW}	$DELTA_X \times t_{PCP}$	ns	—
HSYNC (line) period	t_{HSP}	$(PW_H + BP_H + DELTA_X + FP_H) \times t_{PCP}$	ns	—
—				
VSYNC width	t_{PWV}	$PW_V \times t_{HSP}$	ns	—
VSYNC back porch width	t_{BPV}	$BP_V \times t_{HSP}$	ns	—
VSYNC front porch width	t_{FPV}	$FP_V \times t_{HSP}$	ns	—
Screen height	t_{SH}	$DELTA_Y \times t_{HSP}$	ns	—
VSYNC (frame) period	t_{VSP}	$(PW_V + BP_V + DELTA_Y + FP_H) \times t_{HSP}$	ns	—

Note:

1. Display pixel clock frequency must also be less than or equal to 1/3 of the platform clock

The DELTA_X and DELTA_Y parameters are programmed via the DISP_SIZE register. The PW_H, BP_H, and FP_H parameters are programmed via the HSYN_PARA register; and the PW_V, BP_V, and FP_V parameters are programmed via the VSYN_PARA register.

This figure depicts the synchronous display interface timing for access level, and [Table 57](#) lists the timing parameters.

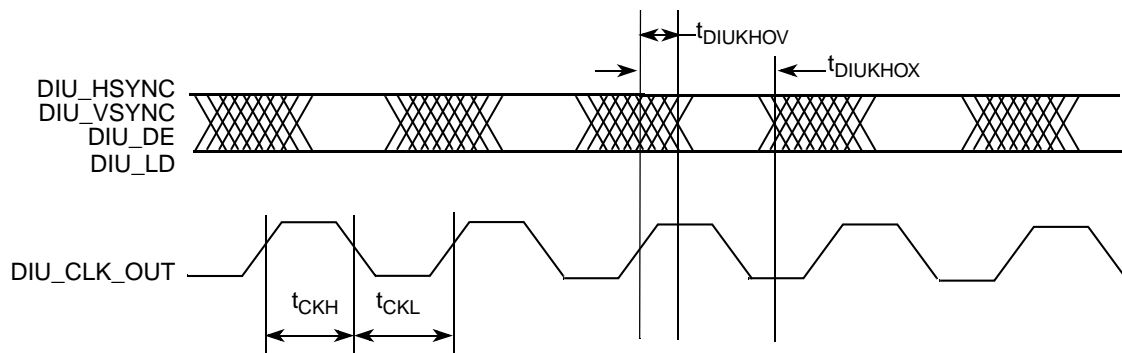

Figure 35. LCD interface timing diagram—access level

NOTE

The DIU_OUT_CLK edge and phase delay is selectable via the Global Utilities CLKDVDR register.

Electrical characteristics

Table 57. LCD interface timing parameters—access level

Parameter	Symbol	Min	Typ	Max	Unit
LCD interface pixel clock high time	t_{CKH}	$0.35 \times t_{PCP}$	$0.5 \times t_{PCP}$	$0.65 \times t_{PCP}$	ns
LCD interface pixel clock low time	t_{CKL}	$0.35 \times t_{PCP}$	$0.5 \times t_{PCP}$	$0.65 \times t_{PCP}$	ns
LCD interface pixel clock to output valid	$t_{DIUKHOV}$	—	—	2	ns
LCD interface output hold from pixel clock	$t_{DIUKHOX}$	$t_{PCP} - 2$	—	—	ns

2.16 Synchronous Serial Interface (SSI)

This section describes the DC and AC electrical specifications for the SSI interface of the device.

2.16.1 SSI DC electrical characteristics

The following table provides SSI DC electrical characteristics.

Table 58. SSI DC electrical characteristics

For recommended operating conditions, see [Table 3](#).

Parameter	Symbol	Min	Max	Unit	Note
High-level input voltage	V_{IH}	2	—	V	1
Low-level input voltage	V_{IL}	—	0.8	V	1
Input current ($OV_{IN}^1 = 0\text{ V}$ or $OV_{IN} = OV_{DD}$)	I_{IN}	—	± 40	μA	2
High-level output voltage ($OV_{DD} = \text{min}$, $I_{OH} = -2\text{ mA}$)	V_{OH}	2.4	—	V	—
Low-level output voltage ($OV_{DD} = \text{min}$, $I_{OL} = 2\text{ mA}$)	V_{OL}	—	0.4	V	—

Note:

1. The min V_{IL} and max V_{IH} values are based on the respective min and max OV_{IN} values found in [Table 3](#).
2. The symbol OV_{IN} represents the input voltage of the supply. It is referenced in [Table 3](#).

2.16.2 SSI AC timing specifications

All timings for the SSI are given:

- for a noninverted serial clock polarity ($STCR[TSCCKP] = 0$, $SRCR[RSCKP] = 1$) and
- for a noninverted frame sync ($STCR[TFSI]$, $SRCR[RFSI] = 1$).

If the polarity of the clock and/or the frame sync have been inverted, all the timing remains valid by inverting the clock signal $STCK$, $SRCK$ and/or the frame sync $STFS$, $SRFS$ shown in the following tables and figures. See the *P1022 QorIQ Integrated Processor Reference Manual* for more information.

2.16.2.1 SSI transmitter timing

This table provides the transmitter timing parameters.

Table 59. SSI transmitter timing parameters

Parameter	Symbol	Min	Max	Unit	Note
STCK clock period	t_{SSI}	81.4	—	ns	—

Table 59. SSI transmitter timing parameters (continued)

Parameter	Symbol	Min	Max	Unit	Note
STCK clock high period	t_{SSI_HIGH}	36.0	—	ns	—
STCK clock rise time	t_{SSIKH}	—	6.0	ns	—
STCK clock low period	t_{SSI_LOW}	36.0	—	ns	—
STCK clock fall time	t_{SSIKL}	—	6.0	ns	—
STCK high to STFS valid	$t_{SSIFSKHOV}$	—	12.0	ns	1
STFS hold time	$t_{SSIFSKHOX}$	-3.0	--	ns	1
STCK high to STXD valid from high impedance	$t_{SSITXKHOV}$	—	12.0	ns	1
STXD hold time	$t_{SSITXKHOX}$	-3.0		ns	1
STFS input setup time	$t_{SSIFSIVKH}$	10.0		ns	—
STFS input hold time	$t_{SSIFSIXKH}$	15.0		ns	—
Synchronous Clock Operation					
SRXD setup time	$t_{SSIRXIVKH}$	10.0	—	ns	—
SRXD hold time	$t_{SSIRXIXKH}$	2.0	—	ns	—

Note:

- Output values are based on 25pF capacitive load.

This figure shows the SSI transmit signal timing.

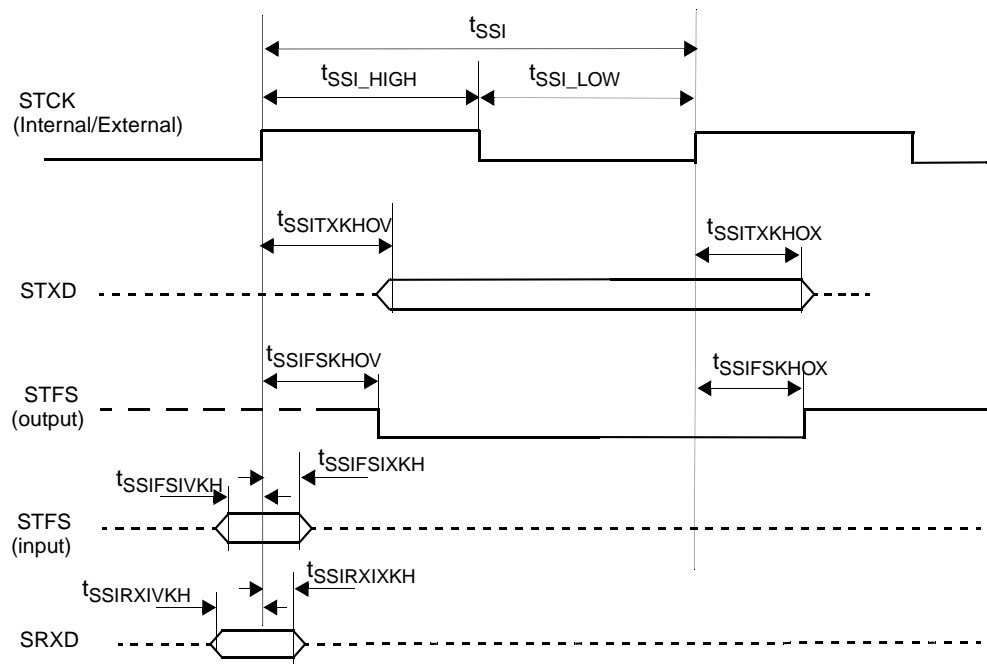
**Note:**

- All timings shown are with respect to STCK
- SRXD input shown for synchronous mode

Figure 36. SSI transmitter timing diagram

2.16.2.2 SSI receiver timing

This table provides the receiver timing parameters.

Table 60. SSI receiver timing parameters

Parameter	Symbol	Min	Max	Unit	Note
SRCK clock period	t_{SSI}	81.4	—	ns	—
SRCK clock high period	t_{SSI_HIGH}	36.0	—	ns	—
SRCK clock rise time	t_{SSIKH}	—	6.0	ns	—
SRCK clock low period	t_{SSI_LOW}	36.0	—	ns	—
SRCK clock fall time	t_{SSIKL}	—	6.0	ns	—
SRCK high to SRFS valid	$t_{SSIFSKHOV}$	—	12.0	ns	1
SRFS hold time	$t_{SSIFSKHOX}$	-3.0		ns	1
SRXD setup time	$t_{SSIRXIVKH}$	10.0	—	ns	—
SRXD hold time	$t_{SSIRXIXKH}$	2.0	—	ns	—
SRFS input setup time	$t_{SSIFSIVKH}$	10.0	—	ns	—
SRFS input hold time	$t_{SSIFSIXKH}$	15.0	—	ns	—

Note:

1. Output values are based on 25pF capacitive load.

This figure shows the SSI receiver timing.

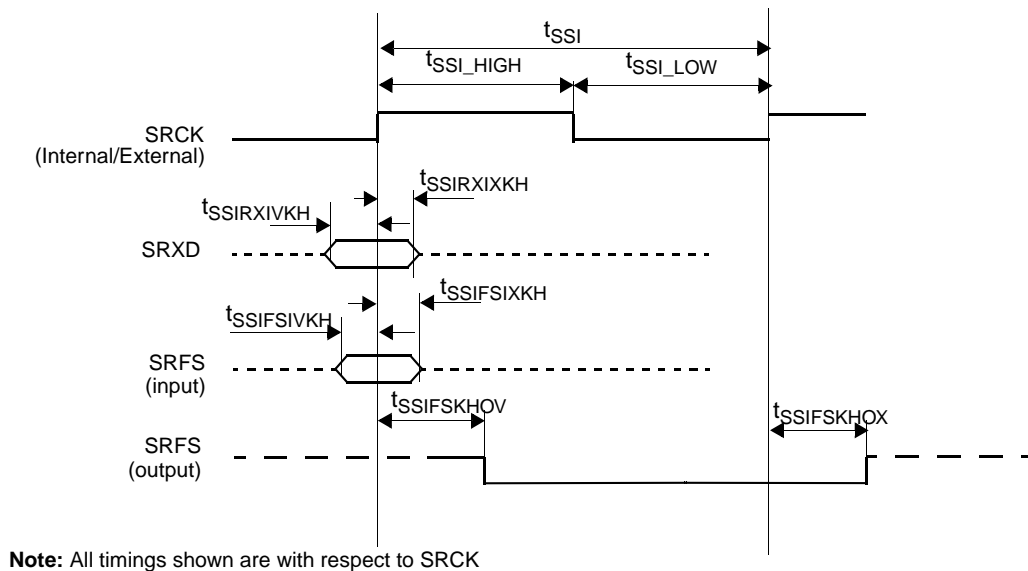

Figure 37. SSI receiver timing diagram

2.17 Programmable Interrupt Controller (PIC) specifications

This section describes the DC and AC electrical specifications for PIC on the device.

2.17.1 PIC DC specifications

This table provides the DC electrical characteristics for the PIC interface.

Table 61. PIC DC electrical characteristics

Parameter	Symbol	Min	Max	Unit	Note
High-level input voltage	V_{IH}	2	—	V	1
Low-level input voltage	V_{IL}	—	0.8	V	1
Input current ($OV_{IN} = 0$ V or $OV_{IN} = OV_{DD}/OV_{DD2}$)	I_{IN}	—	± 40	μ A	2
High-level output voltage ($OV_{DD}/OV_{DD2} = \text{min}$, $I_{OH} = -2$ mA)	V_{OH}	2.4	—	V	—
Low-level output voltage ($OV_{DD} = \text{min}$, $I_{OL} = 2$ mA)	V_{OL}	—	0.4	V	—

Note:

1. The min V_{IL} and max V_{IH} values are based on the min and max OV_{IN} respective values found in [Table 2](#).
2. The symbol V_{IN} , in this case, represents the OV_{IN} symbol referenced in [Table 3](#).

2.17.2 PIC AC timing specifications

This table provides the PIC input and output AC timing specifications.

Table 62. PIC input AC timing specifications

Characteristic	Symbol	Min	Max	Unit	Note
PIC inputs—minimum pulse width	t_{PIWID}	3	—	SYSCCLKs	1

Note:

1. PIC inputs and outputs are asynchronous to any visible clock. IPIC outputs must be synchronized before use by any external synchronous logic. IPIC inputs are required to be valid for at least t_{PIWID} ns to ensure proper operation when working in edge triggered mode

2.18 I²C

This section describes the DC and AC electrical characteristics for the I²C interfaces of the device.

2.18.1 I²C DC electrical characteristics

This table provides the DC electrical characteristics for the I²C interfaces.

Table 63. I²C DC electrical characteristics

Parameter	Symbol	Min	Max	Unit	Note
High-level input voltage	V_{IH}	2	—	V	1
Low-level input voltage	V_{IL}	—	0.8	V	1
Low-level output voltage ($OV_{DD} = \text{min}$, $I_{OL} = 2$ mA)	V_{OL}	0	0.4	V	2

Electrical characteristics

Table 63. I²C DC electrical characteristics (continued)

Pulse width of spikes which must be suppressed by the input filter	t_{12KHKL}	0	50	ns	3
Input current each I/O pin (input voltage is between $0.1 \times OV_{DD}$ and $0.9 \times OV_{DD}(\max)$)	I_I	-10	10	μA	4
Capacitance for each I/O pin	C_I	—	10	pF	—

Note:

1. Note that the min V_{IL} and max V_{IH} values are based on the min and max OV_{IN} respective values found in [Table 2](#).
2. Output voltage (open drain or open collector) condition = 3 mA sink current.
3. See the *P1022 QorIQ Integrated Processor Reference Manual* for information on the digital filter used.
4. I/O pins obstruct the SDA and SCL lines if OV_{DD} is switched off.

2.18.2 I²C AC electrical specifications

This table provides the AC timing parameters for the I²C interfaces.

Table 64. I²C AC electrical specifications

At recommended operating conditions with OV_{DD} of $3.3\text{ V} \pm 5\%$. All values refer to V_{IH} (min) and V_{IL} (max) levels (see [Table 63](#))

Parameter	Symbol ¹	Min	Max	Unit
SCL clock frequency	f_{12C}	0	400	kHz^4
Low period of the SCL clock	t_{12CL}	1.3	—	μs
High period of the SCL clock	t_{12CH}	0.6	—	μs
Setup time for a repeated START condition	t_{12SVKH}	0.6	—	μs
Hold time (repeated) START condition (after this period, the first clock pulse is generated)	t_{12SXKL}	0.6	—	μs
Data setup time	t_{12DVKH}	100	—	ns
Data input hold time: CBUS compatible masters I ² C bus devices	t_{12DXKL}	— 0^2	— —	μs
Data output delay time	t_{12OVKL}	—	0.9^3	μs
Setup time for STOP condition	t_{12PVKH}	0.6	—	μs
Bus free time between a STOP and START condition	t_{12KHDX}	1.3	—	μs
Noise margin at the LOW level for each connected device (including hysteresis)	V_{NL}	$0.1 \times OV_{DD}$	—	V
Noise margin at the HIGH level for each connected device (including hysteresis)	V_{NH}	$0.2 \times OV_{DD}$	—	V
Capacitive load for each bus line	C_b	—	400	pF

Table 64. I²C AC electrical specifications (continued)

At recommended operating conditions with OV_{DD} of $3.3\text{ V} \pm 5\%$. All values refer to V_{IH} (min) and V_{IL} (max) levels (see Table 63)

Parameter	Symbol ¹	Min	Max	Unit
-----------	---------------------	-----	-----	------

Note:

- The symbols used for timing specifications herein follow the pattern $t_{(\text{first two letters of functional block})(\text{signal})(\text{state})(\text{reference})(\text{state})}$ for inputs and $t_{(\text{first two letters of functional block})(\text{reference})(\text{state})(\text{signal})(\text{state})}$ for outputs. For example, t_{I2DVKH} symbolizes I²C timing (I2) with respect to the time data input signals (D) reach the valid state (V) relative to the t_{I2C} clock reference (K) going to the high (H) state or setup time. Also, t_{I2SXKL} symbolizes I²C timing (I2) for the time that the data with respect to the START condition (S) went invalid (X) relative to the t_{I2C} clock reference (K) going to the low (L) state or hold time. Also, t_{I2PVKH} symbolizes I²C timing (I2) for the time that the data with respect to the STOP condition (P) reaching the valid state (V) relative to the t_{I2C} clock reference (K) going to the high (H) state or setup time.
- As a transmitter, the device provides a delay time of at least 300 ns for the SDA signal (referred to the V_{IH} min of the SCL signal) to bridge the undefined region of the falling edge of SCL to avoid unintended generation of START or STOP condition. When the device acts as the I²C bus master while transmitting, the device drives both SCL and SDA. As long as the load on SCL and SDA are balanced, the device would not cause unintended generation of START or STOP condition. Therefore, the 300 ns SDA output delay time is not a concern. If, under some rare condition, the 300 ns SDA output delay time is required for the device as transmitter, application note AN2919 referred to in note 4 below is recommended.
- The maximum t_{I2OVKL} has only to be met if the device does not stretch the LOW period (t_{I2CL}) of the SCL signal.
- The requirements for I²C frequency calculation must be followed. Refer to Freescale application note AN2919, *Determining the I²C Frequency Divider Ratio for SCL*.

This figure provides the AC test load for the I²C.

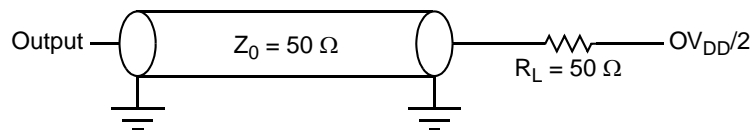
**Figure 38. I²C AC test load**

This figure shows the AC timing diagram for the I²C bus.

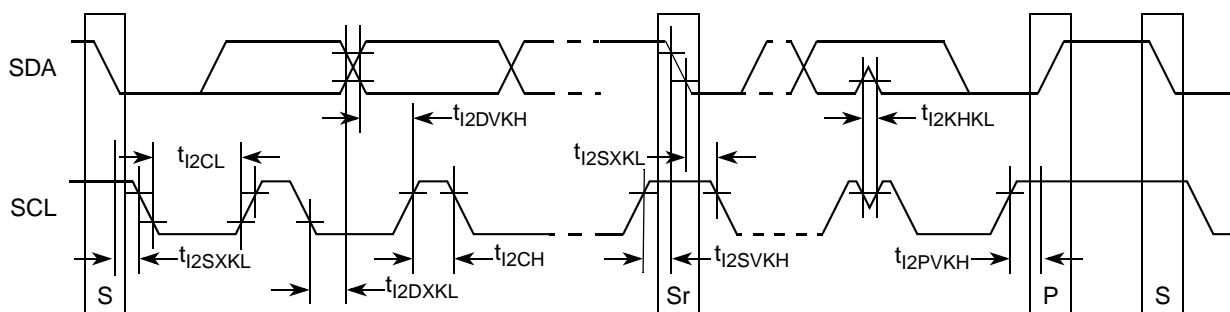
**Figure 39. I²C bus AC timing diagram**

2.19 GPIO

This section describes the DC and AC electrical characteristics for the GPIO interface of the device. There are GPIO pins on various power supplies in this device. For the rest of this section, BV_{IN} and BV_{DD} would stand in for any power supply that the GPIO is running off.

Electrical characteristics

2.19.1 GPIO DC electrical characteristics

This table provides the DC electrical characteristics for the GPIO interface when operating from a 3.3 V supply.

Table 65. GPIO DC electrical characteristics (3.3 V)

For recommended operating conditions, see [Table 3](#).

Parameter	Symbol	Min	Max	Unit	Note
Input high voltage	V_{IH}	2	—	V	1
Input low voltage	V_{IL}	—	0.8	V	1
Input current ($BV_{IN} = 0$ V or $BV_{IN} = BV_{DD}$)	I_{IN}	—	± 40	μA	2
Output high voltage ($BV_{DD} = \text{min}$, $I_{OH} = -2$ mA)	V_{OH}	2.4	—	V	—
Output low voltage ($BV_{DD} = \text{min}$, $I_{OL} = 2$ mA)	V_{OL}	—	0.4	V	—

Note:

1. The min V_{IL} and max V_{IH} values are based on the min and max BV_{IN} respective values found in [Table 3](#).
2. The symbol BV_{IN} represents the input voltage of the supply. It is referenced in [Table 3](#).

This table provides the DC electrical characteristics for the GPIO interface when operating from a 2.5 V supply.

Table 66. GPIO DC electrical characteristics (2.5 V)

For recommended operating conditions, see [Table 3](#).

Parameter	Symbol	Min	Max	Unit	Note
High-level input voltage	V_{IH}	1.7	—	V	1
Low-level input voltage	V_{IL}	—	0.7	V	1
Input current ($V_{IN} = 0$ V or $V_{IN} = BV_{DD}$)	I_{IN}	—	± 40	μA	2
High-level output voltage ($BV_{DD} = \text{min}$, $I_{OH} = -2$ mA)	V_{OH}	1.7	—	V	—
Low-level output voltage ($BV_{DD} = \text{min}$, $I_{OL} = 2$ mA)	V_{OL}	—	0.7	V	—

Note:

1. The min V_{IL} and max V_{IH} values are based on the min and max BV_{IN} respective values found in [Table 3](#).
2. The symbol BV_{IN} represents the input voltage of the supply. It is referenced in [Table 3](#).

This table provides the DC electrical characteristics for the GPIO interface when operating from a 1.8 V supply.

Table 67. GPIO DC electrical characteristics (1.8 V)

For recommended operating conditions, see [Table 3](#).

Parameter	Symbol	Min	Max	Unit	Note
High-level input voltage	V_{IH}	1.2	—	V	1
Low-level input voltage	V_{IL}	—	0.6	V	1
Input current ($BV_{IN} = 0$ V or $BV_{IN} = BV_{DD}$)	I_{IN}	—	± 40	μA	2
High-level output voltage ($BV_{DD} = \text{min}$, $I_{OH} = -0.5$ mA)	V_{OH}	1.35	—	V	—
Low-level output voltage ($BV_{DD} = \text{min}$, $I_{OL} = 0.5$ mA)	V_{OL}	—	0.4	V	—

Note:

1. The min V_{IL} and max V_{IH} values are based on the min and max BV_{IN} respective values found in [Table 3](#).
2. The symbol BV_{IN} represents the input voltage of the supply. It is referenced in [Table 3](#).

2.19.2 GPIO AC electrical specifications

This table provides the GPIO input and output AC timing specifications.

Table 68. GPIO input AC timing specifications

Parameter	Symbol	Min	Unit	Note
GPIO inputs—minimum pulse width	t_{PIWID}	20	ns	1

Note:

- GPIO inputs and outputs are asynchronous to any visible clock. GPIO outputs must be synchronized before use by any external synchronous logic. GPIO inputs are required to be valid for at least t_{PIWID} to ensure proper operation.

This figure provides the AC test load for the GPIO.

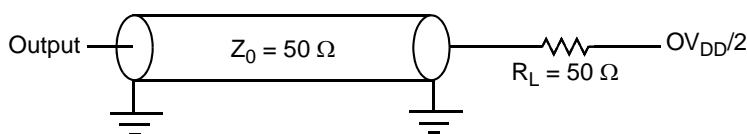

Figure 40. AC test load for GPIO

2.20 TDM

This section describes the DC and AC electrical specifications for the TDM of the device.

2.20.1 TDM DC timing specifications

This table provides the DC electrical characteristics for the TDM interface.

Table 69. TDM DC electrical characteristics

Parameter	Symbol	Min	Max	Unit	Note
High-level input voltage	V_{IH}	2	—	V	1
Low-level input voltage	V_{IL}	—	0.8	V	1
Input current ($OV_{IN} = 0\text{ V}$ or $OV_{IN} = OV_{DD}$)	I_{IN}	—	± 40	μA	2
High-level output voltage ($OV_{DD} = \text{min}$, $I_{OH} = -2\text{ mA}$)	V_{OH}	2.4	—	V	—
Low-level output voltage ($OV_{DD} = \text{min}$, $I_{OL} = 2\text{ mA}$)	V_{OL}	—	0.4	V	—

Note:

- Note that the min V_{IL} and max V_{IH} values are based on the min and max OV_{IN} respective values found in [Table 2](#).
- Note that the symbol V_{IN} , in this case, represents the OV_{IN} symbol referenced in [Table 3](#).

2.20.2 TDM AC timing specifications

This table provides the input and output AC timing specifications for the TDM interface.

Table 70. TDM AC timing specifications

Characteristic	Symbol	Min	Max	Unit	Note
TDMxRCK/TDMxTCK	t_{DM}	62.5	—	ns	5

Table 70. TDM AC timing specifications (continued)

Characteristic	Symbol	Min	Max	Unit	Note
TDMxRCK/TDMxTCK high pulse width	tDM_HIGH	8.0	—	ns	—
TDMxRCK/TDMxTCK low pulse width	tDM_LOW	8.0	—	ns	—
TDM all input setup time	tDMIVKH	3.0	—	ns	—
TDMxRD hold time	tDMRDIXKH	3.5	—	ns	—
TDMxTFS/TDMxRFS input hold time	tDMFSIXKH	2.0	—	ns	—
TDMxTCK High to TDMxTD output active	tDM_OUTAC	4.0	—	ns	—
TDMxTCK High to TDMxTD output valid	tDMTKHOV	—	14.0	ns	—
TDMxTD hold time	tDMTKHOX	2.0	—	ns	—
TDMxTCK High to TDMxTD output high impedance	tDM_OUTHI	—	10.0	ns	—
TDMxTFS/TDMxRFS output valid	tDMFSKHOV	—	13.5	ns	—
TDMxTFS/TDMxRFS output hold time	tDMFSKHOX	2.5	—	ns	—

Note:

1. The symbols used for timing specifications follow the pattern $t_{(first\ two\ letters\ of\ functional\ block)(signal)(state)(reference)(state)}$ for inputs and $t_{(first\ two\ letters\ of\ functional\ block)(reference)(state)(signal)(state)}$ for outputs. For example, t_{HIKHGX} symbolizes the outputs internal timing (HI) for the time t_{serial} memory clock reference (K) goes from the high state (H) until outputs (O) are invalid (X).
2. Output values are based on 30 pF capacitive load.
3. Inputs are referenced to the sampling that the TDM is programmed to use. Outputs are referenced to the programming edge they are programmed to use. Use of the rising edge or falling edge as a reference is programmable. TDMxTCK and TDMxRCK are shown using the rising edge.
4. All values are based on a maximum TDM interface frequency of 50 MHz.
5. The rise / fall time on TDM clock inputs should not exceed 5ns. Rise time refers to signal transitions from 10% to 90% of Vcc; fall time refers to transitions from 90% to 10% of Vcc.

This figure shows the TDM receive signal timing.

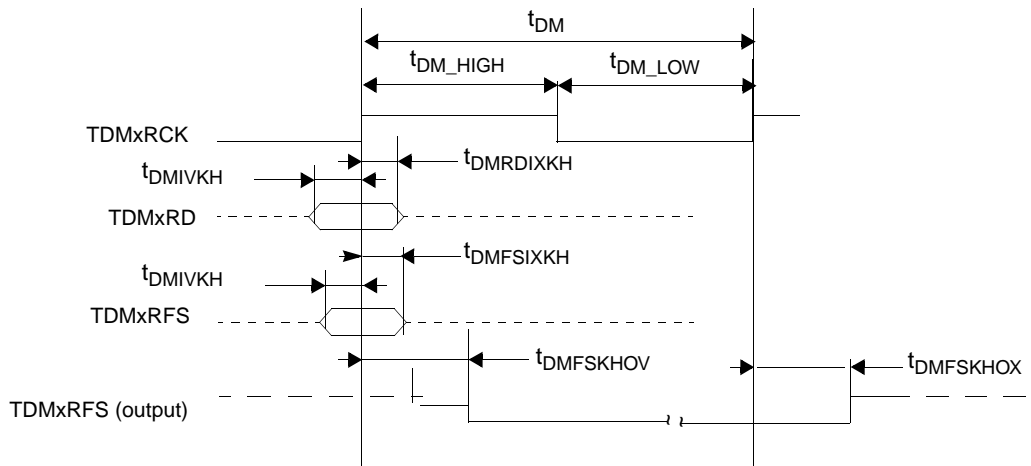

Figure 41. TDM receive signals

This figure shows the TDM transmit signal timing.

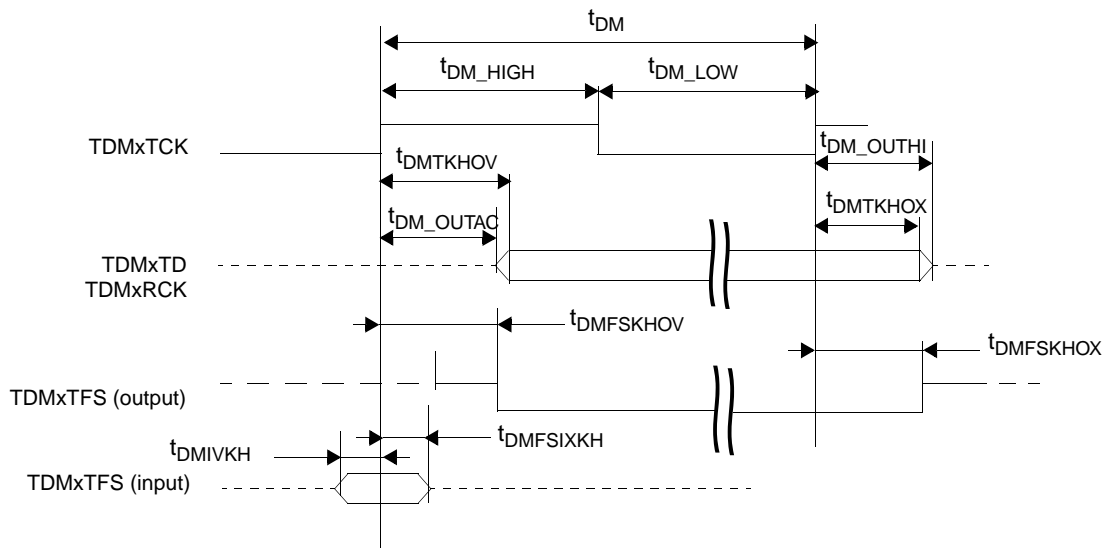

Figure 42. TDM transmit signals

2.21 High-Speed Serial Interfaces (HSSI)

The device features two serializer/deserializer (SerDes) interfaces to be used for high-speed serial interconnect applications. The two SerDes can be configured as various combinations of PCI Express, SATA and SGMII.

This section describes the common portion of SerDes DC electrical specifications, which is the DC requirement for SerDes Reference Clocks. The SerDes data lane's transmitter and receiver reference circuits are also shown.

2.21.1 Signal terms definition

The SerDes utilizes differential signaling to transfer data across the serial link. This section defines terms used in the description and specification of differential signals.

Figure 43 shows how the signals are defined. For illustration purposes, only one SerDes lane is used for description. Figure 43 shows the waveform for either a transmitter output (SDn_TX and $\overline{SDn_TX}$) or a receiver input (SDn_RX and $\overline{SDn_RX}$). Each signal swings between A Volts and B Volts where $A > B$.

Using this waveform, the definitions are as follows. To simplify the illustration, the following definitions assume that the SerDes transmitter and receiver operate in a fully symmetrical differential signaling environment:

1. **Single-ended swing:** The transmitter output signals and the receiver input signals SDn_TX , $\overline{SDn_TX}$, SDn_RX and $\overline{SDn_RX}$ each have a peak-to-peak swing of $A - B$ Volts. This is also referred as each signal wire's Single-Ended Swing.
2. **Differential output voltage, V_{OD} (or differential output swing):** The Differential Output Voltage (or Swing) of the transmitter, V_{OD} , is defined as the difference of the two complimentary output voltages: $V_{SDn_TX} - V_{\overline{SDn_TX}}$. The V_{OD} value can be either positive or negative.
3. **Differential input voltage, V_{ID} (or differential input swing):** The Differential Input Voltage (or Swing) of the receiver, V_{ID} , is defined as the difference of the two complimentary input voltages: $V_{SDn_RX} - V_{\overline{SDn_RX}}$. The V_{ID} value can be either positive or negative.
4. **Differential peak voltage, V_{DIFFp} :** The peak value of the differential transmitter output signal or the differential receiver input signal is defined as Differential Peak Voltage, $V_{DIFFp} = |A - B|$ Volts.

Electrical characteristics

5. **Differential peak-to-peak, $V_{DIFFp-p}$:** Since the differential output signal of the transmitter and the differential input signal of the receiver each range from $A - B$ to $-(A - B)$ Volts, the peak-to-peak value of the differential transmitter output signal or the differential receiver input signal is defined as Differential Peak-to-Peak Voltage, $V_{DIFFp-p} = 2 * V_{DIFFp} = 2 * |(A - B)|$ Volts, which is twice of differential swing in amplitude, or twice of the differential peak. For example, the output differential peak-peak voltage can also be calculated as $V_{TX-DIFFp-p} = 2 * |V_{OD}|$.
6. **Differential waveform:** The differential waveform is constructed by subtracting the inverting signal ($\overline{SDn_TX}$, for example) from the non-inverting signal (SDn_TX , for example) within a differential pair. There is only one signal trace curve in a differential waveform. The voltage represented in the differential waveform is not referenced to ground. Refer to Figure 43 as an example for differential waveform.
7. **Common mode voltage V_{cm} :** The Common Mode Voltage is equal to one half of the sum of the voltages between each conductor of a balanced interchange circuit and ground. In this example, for SerDes output, $V_{cm_out} = (V_{SDn_TX} + V_{\overline{SDn_TX}})/2 = (A + B)/2$, which is the arithmetic mean of the two complimentary output voltages within a differential pair. In a system, the common mode voltage may often differ from one component's output to the other's input. It may be different between the receiver input and driver output circuits within the same component. It is also referred to as the DC offset on some occasions.

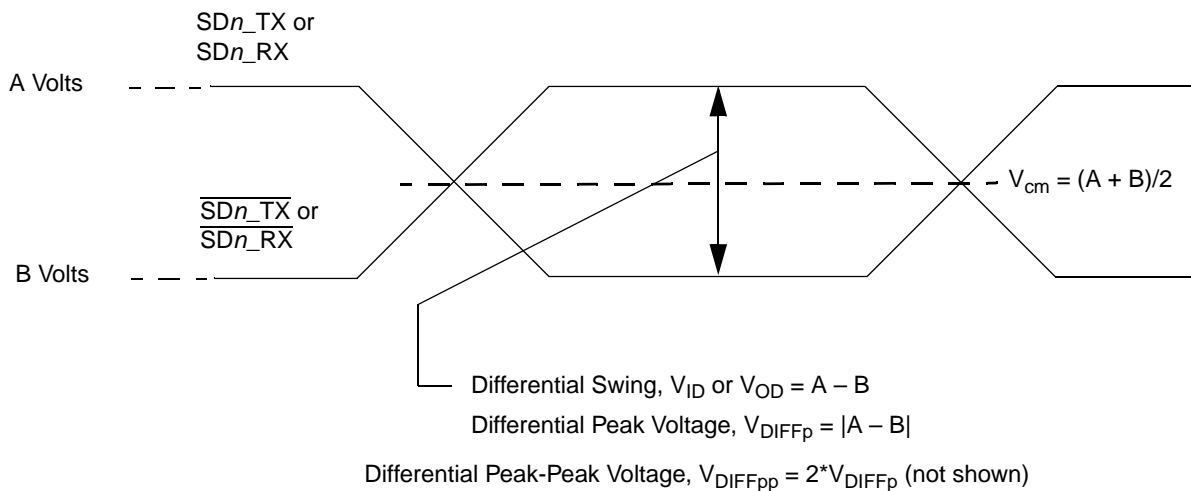

Figure 43. Differential voltage definitions for transmitter or receiver

To illustrate these definitions using real values, consider the case of a current mode logic (CML) transmitter that has a common mode voltage of 2.25 V and each of its outputs, TD and \overline{TD} , has a swing that goes between 2.5 V and 2.0 V. Using these values, the peak-to-peak voltage swing of each signal (TD or \overline{TD}) is 500 mV p-p, which is referred to as the single-ended swing for each signal. In this example, because the differential signaling environment is fully symmetrical, the transmitter output's differential swing (V_{OD}) has the same amplitude as each signal's single-ended swing. The differential output signal ranges between 500 mV and -500 mV. In other words, V_{OD} is 500 mV in one phase and -500 mV in the other phase. The peak differential voltage (V_{DIFFp}) is 500 mV. The peak-to-peak differential voltage ($V_{DIFFp-p}$) is 1000 mV p-p.

2.21.2 SerDes reference clocks

The SerDes reference clock inputs are applied to an internal PLL whose output creates the clock used by the corresponding SerDes lanes. The SerDes reference clock inputs are SD1_REF_CLK and SD2_REF_CLK for the two SerDes on P1013. These can be configured to be used by PCI Express, SATA the SGMII interface. See the *P1022 QorIQ Integrated Processor Reference Manual* for configuration details.

The following sections describe the SerDes reference clock requirements and some application information.

2.21.2.1 SerDes reference clock receiver characteristics

This figure shows a receiver reference diagram of the SerDes reference clocks.

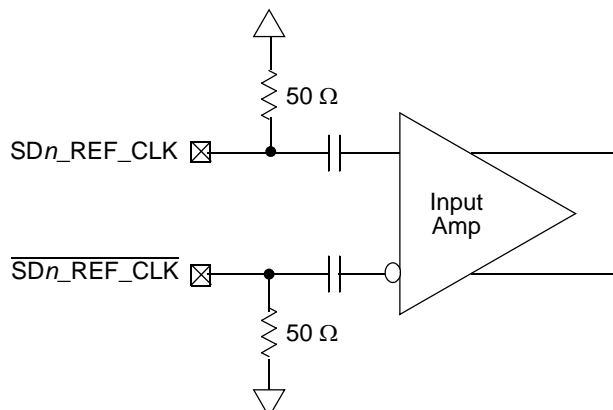

Figure 44. Receiver of SerDes reference clocks

The characteristics are as follows:

- The supply voltage requirements for SV_{DD} and SV_{DD2} are specified in [Table 2](#) and [Table 3](#).
- SerDes Reference Clock Receiver Reference Circuit Structure
 - The SDn_REF_CLK and $\overline{SDn_REF_CLK}$ are internally AC-coupled differential inputs as shown in [Figure 44](#). Each differential clock input (SDn_REF_CLK or $\overline{SDn_REF_CLK}$) has on-chip 50- Ω termination to SV_{SSn} followed by on-chip AC-coupling.
 - The external reference clock driver must be able to drive this termination.
 - The SerDes reference clock input can be either differential or single-ended. Refer to the Differential Mode and Single-ended Mode description below for further detailed requirements.
- The maximum average current requirement that also determines the common mode voltage range.
 - When the SerDes reference clock differential inputs are DC coupled externally with the clock driver chip, the maximum average current allowed for each input pin is 8 mA. In this case, the exact common mode input voltage is not critical as long as it is within the range allowed by the maximum average current of 8 mA (refer to the following bullet for more detail), because the input is AC-coupled on-chip.
 - This current limitation sets the maximum common mode input voltage to be less than 0.4 V ($0.4\text{ V}/50 = 8\text{ mA}$) while the minimum common mode input level is 0.1 V above SV_{SSn} . For example, a clock with a 50/50 duty cycle can be produced by a clock driver with output driven by its current source from 0 mA to 16 mA (0–0.8 V), such that each phase of the differential input has a single-ended swing from 0 V to 800 mV with the common mode voltage at 400 mV.
 - If the device driving the SDn_REF_CLK and $\overline{SDn_REF_CLK}$ inputs cannot drive 50 Ω to SV_{SSn} DC, or it exceeds the maximum input current limitations, then it must be AC-coupled off-chip.
- The input amplitude requirement is as follows:
 - This requirement is described in detail in the following sections.

2.21.3 DC level requirement for SerDes reference clocks

The DC level requirement for the P1013 SerDes reference clock inputs is different depending on the signaling mode used to connect the clock driver chip and SerDes reference clock inputs as described below:

- **Differential mode**
 - The input amplitude of the differential clock must be between 400 mV and 1600 mV differential peak-peak (or between 200 mV and 800 mV differential peak). In other words, each signal wire of the differential pair must have

Electrical characteristics

a single-ended swing less than 800 mV and greater than 200 mV. This requirement is the same for both external DC-coupled or AC-coupled connection.

- For **external DC-coupled** connection, as described in [Section 2.21.2.1, “SerDes reference clock receiver characteristics,”](#) the maximum average current requirements sets the requirement for average voltage (common mode voltage) to be between 100 mV and 400 mV. [Figure 45](#) shows the SerDes reference clock input requirement for DC-coupled connection scheme.
 - For **external AC-coupled** connection, there is no common mode voltage requirement for the clock driver. Since the external AC-coupling capacitor blocks the DC level, the clock driver and the SerDes reference clock receiver operate in different command mode voltages. The SerDes reference clock receiver in this connection scheme has its common mode voltage set to SV_{SSn} . Each signal wire of the differential inputs is allowed to swing below and above the command mode voltage (SV_{SSn}). [Figure 46](#) shows the SerDes reference clock input requirement for AC-coupled connection scheme.
- **Single-ended mode**
 - The reference clock can also be single-ended. The SDn_REF_CLK input amplitude (single-ended swing) must be between 400 mV and 800 mV peak-peak (from V_{MIN} to V_{MAX}) with $\overline{SDn_REF_CLK}$ either left unconnected or tied to ground.
 - The SDn_REF_CLK input average voltage must be between 200 and 400 mV. [Figure 47](#) shows the SerDes reference clock input requirement for single-ended signaling mode.
 - To meet the input amplitude requirement, the reference clock inputs might need to be DC or AC-coupled externally. For the best noise performance, the reference of the clock could be DC or AC-coupled into the unused phase ($\overline{SDn_REF_CLK}$) through the same source impedance as the clock input (SDn_REF_CLK) in use.

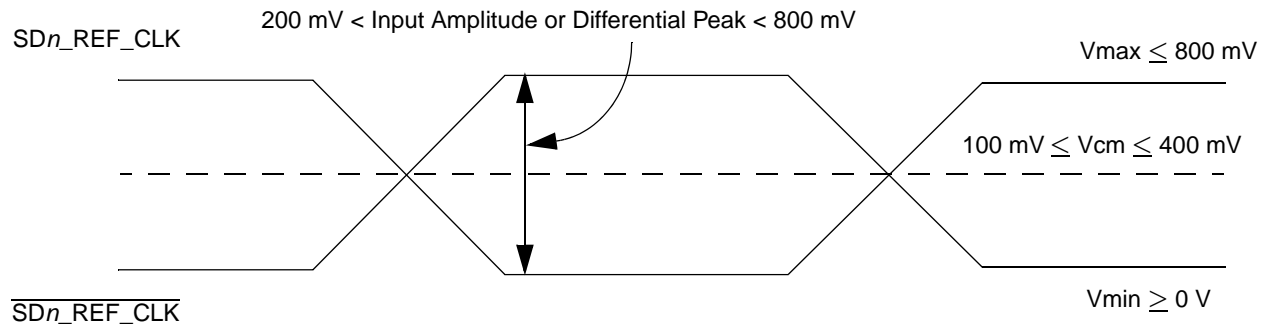

Figure 45. Differential reference clock input DC requirements (external DC-coupled)

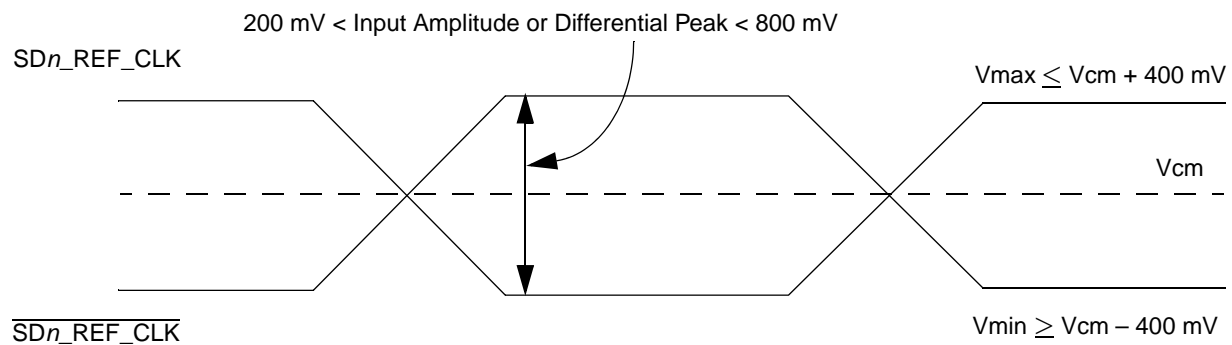

Figure 46. Differential reference clock input DC requirements (External AC-coupled)

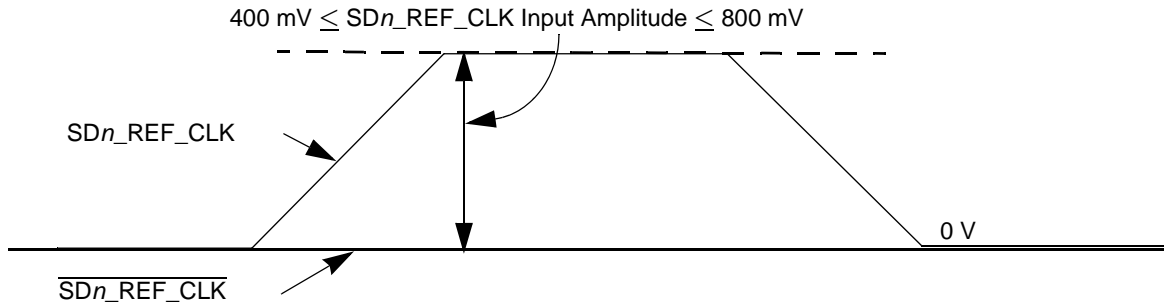

Figure 47. Single-ended reference clock input DC requirements

2.21.3.1 AC requirements for SerDes reference clocks

This table lists AC requirements for the PCI Express and SGMII SerDes reference clocks to be guaranteed by the customer's application design.

Table 71. SD_REF_CLK and $\overline{\text{SD_REF_CLK}}$ input clock requirements

Parameter	Symbol	Min	Typical	Max	Unit	Note
SD_REF_CLK/ $\overline{\text{SD_REF_CLK}}$ frequency range	$t_{\text{CLK_REF}}$	—	100/125	—	MHz	1
SD_REF_CLK/ $\overline{\text{SD_REF_CLK}}$ clock frequency tolerance	$t_{\text{CLK_TOL}}$	-350	—	+350	ppm	—
SD_REF_CLK/ $\overline{\text{SD_REF_CLK}}$ reference clock duty cycle	$t_{\text{CLK_DUTY}}$	40	50	60	%	4
SD_REF_CLK/ $\overline{\text{SD_REF_CLK}}$ max deterministic peak-peak Jitter at 10^{-6} BER	$t_{\text{CLK_DJ}}$	—	—	42	ps	—
SD_REF_CLK/ $\overline{\text{SD_REF_CLK}}$ total reference clock jitter at 10^{-6} BER (Peak-to-peak jitter at refClk input)	$t_{\text{CLK_TJ}}$	—	—	86	ps	2
SD_REF_CLK/ $\overline{\text{SD_REF_CLK}}$ rising/falling edge rate	$t_{\text{CLKRR}}/t_{\text{CLKFR}}$	1	—	4	V/ns	3

Note:

- Only 100/125 have been tested, other in between values do not work correctly with the rest of the system.
- Limits from PCI Express CEM Rev 2.0
- Measured from -200 mV to +200 mV on the differential waveform (derived from $\text{SD}_n\text{_REF_CLK}$ minus $\overline{\text{SD}_n\text{_REF_CLK}}$). The signal must be monotonic through the measurement region for rise and fall time. The 400 mV measurement window is centered on the differential zero crossing. See [Figure 48](#).
- Measurement taken from differential waveform
- Measurement taken from single-ended waveform
- Matching applies to rising edge for $\text{SD}_n\text{_REF_CLK}$ and falling edge rate for $\overline{\text{SD}_n\text{_REF_CLK}}$. It is measured using a 200 mV window centered on the median cross point where $\text{SD}_n\text{_REF_CLK}$ rising meets $\overline{\text{SD}_n\text{_REF_CLK}}$ falling. The median cross point is used to calculate the voltage thresholds that the oscilloscope uses for the edge rate calculations. The rise edge rate of $\text{SD}_n\text{_REF_CLK}$ must be compared to the fall edge rate of $\overline{\text{SD}_n\text{_REF_CLK}}$, the maximum allowed difference should not exceed 20% of the slowest edge rate. See [Figure 49](#).

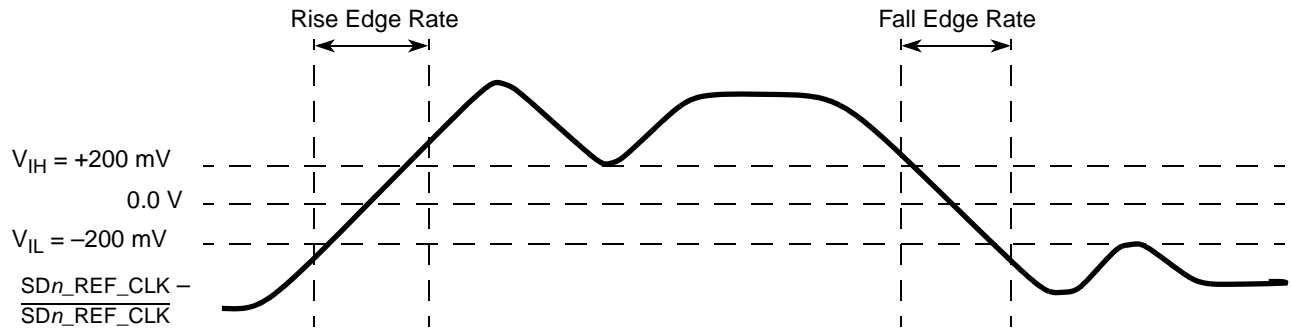

Figure 48. Differential measurement points for rise and fall time

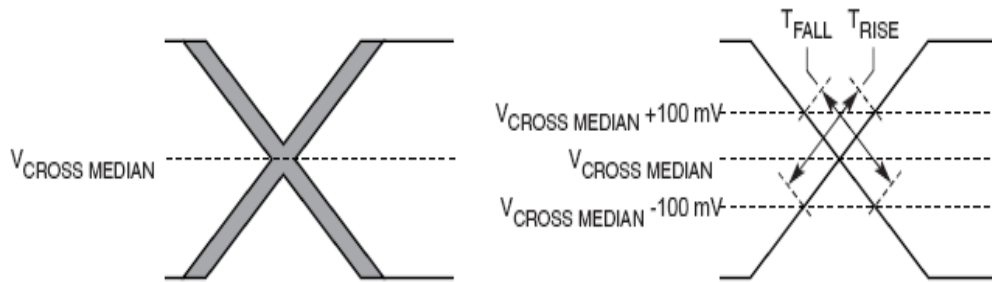

Figure 49. Single-ended measurement points for rise and fall time matching

2.21.4 SerDes transmitter and receiver reference circuits

This figure shows the reference circuits for SerDes data lane’s transmitter and receiver.

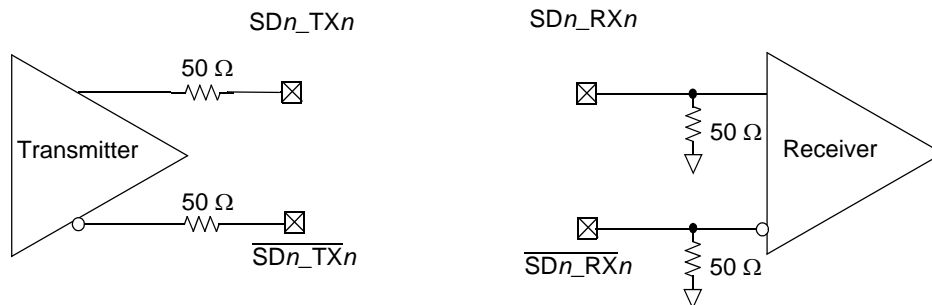

Figure 50. SerDes transmitter and receiver reference circuits

The DC and AC specification of SerDes data lanes are defined in each interface protocol section below (PCI Express, SGMII and SATA) in this document based on the application usage:

- [Section 2.11.6, “SGMII interface electrical characteristics”](#)
- [Section 2.22, “PCI express”](#)
- [Section 2.23, “Serial ATA \(SATA\)”](#)

Note that external AC Coupling capacitor is required for the above three serial transmission protocols per the protocol’s standard requirements.

2.21.5 Clocking dependencies

The ports on the two ends of a link must transmit data at a rate that is within 600 parts per million (ppm) of each other at all times. This is specified to allow bit rate clock sources with a ± 300 ppm tolerance.

2.22 PCI express

This section describes the DC and AC electrical specifications for the PCI Express bus of the device.

2.22.1 DC requirements for PCI express SerDes reference clocks

For more information, see [Section 2.21.3, “DC level requirement for SerDes reference clocks.”](#)

2.22.2 AC requirements for PCI express SerDes reference clocks

For more information, see [Section 2.21.3.1, “AC requirements for SerDes reference clocks.”](#)

2.22.2.1 PCI express physical layer transmitter specifications

The following is a summary of the specifications for the physical layer of PCI Express on this device.

2.22.2.1.1 PCI express (2.5Gb/s) differential transmitter (TX) output

This table defines the PCI Express (2.5 Gb/s) DC specifications for the differential output at all transmitters (TXs). The parameters are specified at the component pins.

Table 72. PCI express (2.5Gb/s) differential transmitter (TX) output DC specifications

Symbol	Parameter	Min	Typical	Max	Unit	Comments
$V_{TX-DIFFp-p}$	Differential peak-to-peak output voltage	800	1000	1200	mV	$V_{TX-DIFFp-p} = 2 * V_{TX-D+} - V_{TX-D-} $ See Note 1.
$V_{TX-DE-RATIO}$	De-emphasized differential output voltage (ratio)	3.0	3.5	4.0	dB	Ratio of the $V_{TX-DIFFp-p}$ of the second and following bits after a transition divided by the $V_{TX-DIFFp-p}$ of the first bit after a transition. See Note 1.
$Z_{TX-DIFF-DC}$	DC differential TX impedance	80	100	120	Ω	TX DC Differential mode low impedance
Z_{TX-DC}	Transmitter DC impedance	40	50	60	Ω	Required TX D+ as well as D- DC impedance during all states

Note:

1. Specified at the measurement point into a timing and voltage compliance test load as shown in [Figure 51](#) and measured over any 250 consecutive TX UIs.

Electrical characteristics

This table defines the PCI Express (2.5Gb/s) AC specifications for the differential output at all transmitters (TXs). The parameters are specified at the component pins. The AC timing specifications do not include RefClk jitter.

Table 73. PCI Express (2.5Gb/s) differential transmitter (TX) output AC specifications

Symbol	Parameter	Min	Typical	Max	Unit	Comments
UI	Unit interval	399.88	400.00	400.12	ps	Each UI is 400 ps \pm 300 ppm. UI does not account for Spread Spectrum Clock dictated variations. See Note 1.
T_{TX-EYE}	Minimum TX eye width	0.70	—	—	UI	The maximum Transmitter jitter can be derived as $T_{TX-MAX-JITTER} = 1 - T_{TX-EYE} = 0.3$ UI. See Notes 2 and 3.
$T_{TX-EYE-MEDIAN-to-MAX-JITTER}$	Maximum time between the jitter median and maximum deviation from the median.	—	—	0.15	UI	Jitter is defined as the measurement variation of the crossing points ($V_{TX-DIFFp-p} = 0$ V) in relation to a recovered TX UI. A recovered TX UI is calculated over 3500 consecutive unit intervals of sample data. Jitter is measured using all edges of the 250 consecutive UI in the center of the 3500 UI used for calculating the TX UI. See Notes 2 and 3.
C_{TX}	AC coupling capacitor	75	—	200	nF	All Transmitters are AC coupled. The AC coupling is required either within the media or within the transmitting component itself. See Note 4.

Note:

- No test load is necessarily associated with this value.
- Specified at the measurement point into a timing and voltage compliance test load as shown in [Figure 51](#) and measured over any 250 consecutive TX UIs.
- A $T_{TX-EYE} = 0.70$ UI provides for a total sum of deterministic and random jitter budget of $T_{TX-JITTER-MAX} = 0.30$ UI for the Transmitter collected over any 250 consecutive TX UIs. The $T_{TX-EYE-MEDIAN-to-MAX-JITTER}$ median is less than half of the total TX jitter budget collected over any 250 consecutive TX UIs. It must be noted that the median is not the same as the mean. The jitter median describes the point in time where the number of jitter points on either side is approximately equal as opposed to the averaged time value.
- P1013 SerDes transmitter does not have CTX built-in. An external AC Coupling capacitor is required.

2.22.3 PCI express physical layer receiver specifications

This section contains the following subsections:

- [Section 2.22.3.1, “PCI express \(2.5 Gb/s\) differential receiver \(RX\) input specifications”](#)
- [Section 2.22.4, “Compliance test and measurement load”](#)

2.22.3.1 PCI express (2.5 Gb/s) differential receiver (RX) input specifications

This table defines the DC specifications for the PCI Express (2.5 Gb/s) differential input at all receivers (RXs). The parameters are specified at the component pins.

Table 74. PCI Express (2.5 Gb/s) differential receiver (RX) input DC specifications

Symbol	Parameter	Min	Typical	Max	Unit	Comments
$V_{RX-DIFFp-p}$	Differential input peak-to-peak voltage	235	—	1200	mV	$V_{RX-DIFFp-p} = 2 * V_{RX-D+} - V_{RX-D-} $ See Note 1.
$Z_{RX-DIFF-DC}$	DC differential input impedance	80	100	120	Ω	RX DC Differential mode impedance. See Note 2

Table 74. PCI Express (2.5 Gb/s) differential receiver (RX) input DC specifications (continued)

Symbol	Parameter	Min	Typical	Max	Unit	Comments
Z _{RX-DC}	DC input impedance	40	50	60	Ω	Required RX D+ as well as D- DC Impedance (50 ± 20% tolerance). See Notes 1 and 2.
Z _{RX-HIGH-IMP-DC}	Powered down DC input impedance	50 k	—	—	Ω	Required RX D+ as well as D- DC Impedance when the Receiver terminations do not have power. See Note 3.
V _{RX-IDLE-DET-DIFF} p-p	Electrical idle detect threshold	65	—	235	mV	$V_{RX-IDLE-DET-DIFF\ p-p} = 2 * V_{RX-D+} - V_{RX-D-} $ Measured at the package pins of the Receiver

Note:

1. Specified at the measurement point and measured over any 250 consecutive UIs. The test load in Figure 51 must be used as the RX device when taking measurements. If the clocks to the RX and TX are not derived from the same reference clock, the TX UI recovered from 3500 consecutive UI must be used as a reference for the eye diagram.
2. Impedance during all LTSSM states. When transitioning from a Fundamental Reset to Detect (the initial state of the LTSSM) there is a 5 ms transition time before Receiver termination values must be met on all un-configured Lanes of a Port.
3. The RX DC Common Mode Impedance that exists when no power is present or Fundamental Reset is asserted. This helps ensure that the Receiver Detect circuit does not falsely assume a Receiver is powered on when it is not. This term must be measured at 300 mV above the RX ground.

This table defines the AC specifications for the PCI Express (2.5 Gb/s) differential input at all receivers (RXs). The parameters are specified at the component pins. The AC timing specifications do not include RefClk jitter.

Table 75. PCI express (2.5 Gb/s) differential receiver (RX) input AC specifications

Symbol	Parameter	Min	Typical	Max	Unit	Comments
UI	Unit interval	399.8 8	400.00	400.12	ps	Each UI is 400 ps ± 300 ppm. UI does not account for Spread Spectrum Clock dictated variations. See Note 1.
T _{RX-EYE}	Minimum receiver eye width	0.4	—	—	UI	The maximum interconnect media and Transmitter jitter that can be tolerated by the Receiver can be derived as $T_{RX-MAX-JITTER} = 1 - T_{RX-EYE} = 0.6$ UI. See Notes 2 and 3.
T _{RX-EYE-MEDIAN-to-MAX-JITTER}	Maximum time between the jitter median and maximum deviation from the median.	—	—	0.3	UI	Jitter is defined as the measurement variation of the crossing points ($V_{RX-DIFF\ p-p} = 0$ V) in relation to a recovered TX UI. A recovered TX UI is calculated over 3500 consecutive unit intervals of sample data. Jitter is measured using all edges of the 250 consecutive UI in the center of the 3500 UI used for calculating the TX UI. See Notes 2, 3 and 4.

Table 75. PCI express (2.5 Gb/s) differential receiver (RX) input AC specifications (continued)

Symbol	Parameter	Min	Typical	Max	Unit	Comments
--------	-----------	-----	---------	-----	------	----------

Note:

1. No test load is necessarily associated with this value.
2. Specified at the measurement point and measured over any 250 consecutive UIs. The test load in Figure 51 must be used as the RX device when taking measurements. If the clocks to the RX and TX are not derived from the same reference clock, the TX UI recovered from 3500 consecutive UI must be used as a reference for the eye diagram.
3. A $T_{RX-EYE} = 0.40$ UI provides for a total sum of 0.60 UI deterministic and random jitter budget for the Transmitter and interconnect collected any 250 consecutive UIs. The TRX-EYE-MEDIAN-to-MAX-JITTER specification ensures a jitter distribution in which the median and the maximum deviation from the median is less than half of the total. UI jitter budget collected over any 250 consecutive TX UIs. It must be noted that the median is not the same as the mean. The jitter median describes the point in time where the number of jitter points on either side is approximately equal as opposed to the averaged time value. If the clocks to the RX and TX are not derived from the same reference clock, the TX UI recovered from 3500 consecutive UI must be used as the reference for the eye diagram.
4. It is recommended that the recovered TX UI is calculated using all edges in the 3500 consecutive UI interval with a fit algorithm using a minimization merit function. Least squares and median deviation fits have worked well with experimental and simulated data.

2.22.4 Compliance test and measurement load

The AC timing and voltage parameters must be verified at the measurement point, as specified within 0.2 inches of the package pins, into a test/measurement load shown in Figure 51.

NOTE

The allowance of the measurement point to be within 0.2 inches of the package pins is meant to acknowledge that package/board routing may benefit from D+ and D– not being exactly matched in length at the package pin boundary. If the vendor does not explicitly state where the measurement point is located, the measurement point is assumed to be the D+ and D– package pins.

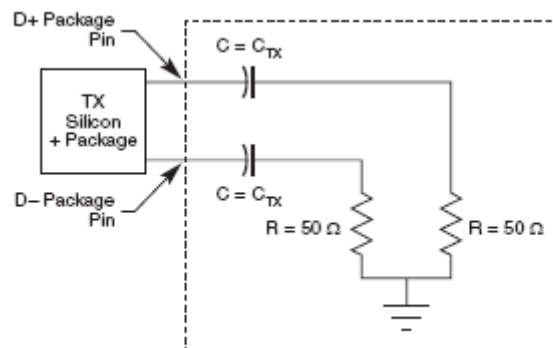

Figure 51. Compliance test/measurement load

2.23 Serial ATA (SATA)

This section describes the DC and AC electrical specifications for the serial ATA (SATA) of the device. External cabled applications or long backplane applications (Gen1x & Gen2x) are not supported for the device.

2.23.1 AC requirements for SATA reference clock

The AC requirements for the SATA reference clock are listed in the [Table 76](#) to be guaranteed by the customer's application design.

Table 76. SATA reference clock Input Requirements

Parameter	Symbol	Conditions	Min	Typical	Max	Unit	Note
SD_REF_CLK/ $\overline{\text{SD_REF_CLK}}$ frequency range	$t_{\text{CLK_REF}}$	—	—	100/125	—	MHz	1
SD_REF_CLK/ $\overline{\text{SD_REF_CLK}}$ clock frequency tolerance	$t_{\text{CLK_TOL}}$	—	-350	—	+350	ppm	—
SD_REF_CLK/ $\overline{\text{SD_REF_CLK}}$ reference clock duty cycle	$t_{\text{CLK_DUTY}}$	Measured at 1.6 V	40	50	60	%	—
SD_REF_CLK/ $\overline{\text{SD_REF_CLK}}$ cycle to cycle Clock jitter (period jitter)	$t_{\text{CLK_CJ}}$	Cycle to cycle at RefClk input	—	—	100	ps	—
SD_REF_CLK/ $\overline{\text{SD_REF_CLK}}$ total reference clock jitter, phase jitter (peak-peak)	$t_{\text{CLK_PJ}}$	Peak-to-peak jitter at refClk input	-50	—	+50	ps	2, 3

Note:

1. Only 100/125 MHz have been tested; other in-between values do not work correctly with the rest of the system.
2. In a frequency band from 150 kHz to 15 MHz at BER of 10^{-12}
3. Total peak to peak Deterministic Jitter "DJ" must be less than or equal to 50ps.

2.23.2 Transmitter (TX) output characteristics

2.23.3 Gen1i/1.5G transmitter (TX) specifications

This table provides the DC differential transmitter (TX) output DC characteristics for the SATA interface at Gen1i or 1.5 Gbits/s transmission.

Table 77. Gen1i/1.5G transmitter (TX) DC specifications

Parameter	Symbol	Min	Typical	Max	Unit	Note
TX diff output voltage	$V_{\text{SATA_TXDIFF}}$	400	500	600	mV p-p	1
TX differential pair impedance	$Z_{\text{SATA_TXDIFFIM}}$	85	100	115	Ω	2

Note:

1. Terminated by 50 Ω load.
2. DC Impedance

This table provides the differential transmitter (TX) output AC characteristics for the SATA interface at Gen1i or 1.5 Gbits/s transmission. The AC timing specifications do not include RefClk jitter.

Table 78. Gen1i/1.5G transmitter (TX) AC specifications

Parameter	Symbol	Min	Typical	Max	Unit	Note
Channel speed	$t_{\text{CH_SPEED}}$	—	1.5	—	Gbps	—
Unit interval	T_{UI}	666.4333	666.6667	670.2333	ps	—
Total jitter data-data 5UI	$U_{\text{SATA_TXTJ5UI}}$	—	—	0.355	UI p-p	1
Total jitter, data-data 250UI	$U_{\text{SATA_TXTJ250UI}}$	—	—	0.47	UI p-p	1
Deterministic jitter, data-data 5UI	$U_{\text{SATA_TXDJ5UI}}$	—	—	0.175	UI p-p	1

Electrical characteristics

Table 78. Gen1i/1.5G transmitter (TX) AC specifications

Parameter	Symbol	Min	Typical	Max	Unit	Note
Deterministic jitter, data-data 250UI	$U_{SATA_TXDJ250UI}$	—	—	0.22	UI p-p	1

Note:

1. Measured at Tx output pins peak to peak phase variation, Random data pattern

2.23.4 Gen2i/3G transmitter (TX) specifications

This table provides the differential transmitter (TX) output DC characteristics for the SATA interface at Gen2i or 3.0 Gbits/s transmission.

Table 79. Gen 2i/3G transmitter (TX) DC specifications

Parameter	Symbol	Min	Typical	Max	Unit	Note
TX Diff Output Voltage	V_{SATA_TXDIFF}	400	550	700	mV p-p	1
TX Differential pair impedance	$Z_{SATA_TXDIFFIM}$	85	100	115	Ω	—

Note:

1. Terminated by 50 Ω load.

This table provides the differential transmitter (TX) output AC characteristics for the SATA interface at Gen2i or 3.0 Gbits/s transmission. The AC timing specifications do not include RefClk jitter.

Table 80. Gen 2i/3G transmitter (TX) AC specifications

Parameter	Symbol	Min	Typical	Max	Unit	Note
Channel Speed	t_{CH_SPEED}	—	3.0	—	Gbps	—
Unit Interval	T_{UI}	333.2167	333.3333	335.1167	ps	—
Total Jitter fC3dB=fBAUD/10	$U_{SATA_TXTJfB/10}$	—	—	0.3	UI p-p	1
Total Jitter fC3dB=fBAUD/500	$U_{SATA_TXTJfB/500}$	—	—	0.37	UI p-p	1
Total Jitter fC3dB=fBAUD/1667	$U_{SATA_TXTJfB/1667}$	—	—	0.55	UI p-p	1
Deterministic jitter, fC3dB=fBAUD/10	$U_{SATA_TXDJfB/10}$	—	—	0.17	UI p-p	1
Deterministic jitter, fC3dB=fBAUD/500	$U_{SATA_TXDJfB/500}$	—	—	0.19	UI p-p	1
Deterministic jitter, fC3dB=fBAUD/1667	$U_{SATA_TXDJfB/1667}$	—	—	0.35	UI p-p	1

Note:

1. Measured at Tx output pins peak to peak phase variation, Random data pattern

2.23.5 Differential receiver (RX) input characteristics

2.23.5.1 Gen1i/1.5G receiver (RX) specifications

This table provides the Gen1i or 1.5Gbits/s differential receiver (RX) input DC characteristics for the SATA interface.

Table 81. Gen1i/1.5G receiver (RX) input DC specifications

Parameter	Symbol	Min	Typical	Max	Unit	Note
Differential input voltage	V_{SATA_RXDIFF}	240	500	600	mV p-p	1
Differential RX input impedance	Z_{SATA_RXSEIM}	85	100	115	Ω	—
OOB signal detection threshold	V_{SATA_OOB}	50	120	240	mV p-p	—

Note:

1. Voltage relative to common of either signal comprising a differential pair

This table provides the Gen1i or 1.5 Gbits/s differential receiver (RX) input AC characteristics for the SATA interface. The AC timing specifications do not include RefClk jitter.

Table 82. Gen 1i/1.5G receiver (RX) AC specifications

Parameter	Symbol	Min	Typical	Max	Unit	Note
Unit interval	T_{UI}	666.4333	666.6667	670.2333	ps	—
Total jitter data-data 5UI	$U_{SATA_TXTJ5UI}$	—	—	0.43	UI p-p	1
Total jitter, data-data 250UI	$U_{SATA_TXTJ250UI}$	—	—	0.60	UI p-p	1
Deterministic jitter, data-data 5UI	$U_{SATA_TXDJ5UI}$	—	—	0.25	UI p-p	1
Deterministic jitter, data-data 250UI	$U_{SATA_TXDJ250UI}$	—	—	0.35	UI p-p	1

Note:

1. Measured at Receiver

2.23.5.2 Gen2i/3G receiver (RX) specifications

This table provides the Gen2i or 3Gbits/s differential receiver (RX) input DC characteristics for the SATA interface.

Table 83. Gen2i/3G receiver (RX) input DC specifications

Parameter	Symbol	Min	Typical	Max	Unit	Note
Differential input voltage	V_{SATA_RXDIFF}	275	500	750	mV p-p	1
Differential RX input impedance	Z_{SATA_RXSEIM}	85	100	115	ohm	2
OOB signal detection threshold	V_{SATA_OOB}	75	120	275	mV p-p	3

Note:

1. Voltage relative to common of either signal comprising a differential pair
2. DC Impedance
3. Measured at package pins of the receiver

This table provides the differential receiver (RX) input AC characteristics for the SATA interface at Gen2i or 3.0 Gbits/s transmission. The AC timing specifications do not include RefClk jitter.

Table 84. Gen 2i/3G receiver (RX) AC specifications

Parameter	Symbol	Min	Typical	Max	Unit	Note
Unit interval	T_{UI}	333.2167	333.3333	335.1167	ps	—
Total jitter fC3dB=fBAUD/10	$U_{SATA_TXTJfB/10}$	—	—	0.46	UI p-p	1
Total jitter fC3dB=fBAUD/500	$U_{SATA_TXTJfB/500}$	—	—	0.60	UI p-p	1

Electrical characteristics

Table 84. Gen 2i/3G receiver (RX) AC specifications (continued)

Parameter	Symbol	Min	Typical	Max	Unit	Note
Total jitter fC3dB=fBAUD/1667	$U_{SATA_TXTJfB/1667}$	—	—	0.65	UI p-p	1
Deterministic jitter, fC3dB=fBAUD/10	$U_{SATA_TXDJfB/10}$	—	—	0.35	UI p-p	1
Deterministic jitter, fC3dB=fBAUD/500	$U_{SATA_TXDJfB/500}$	—	—	0.42	UI p-p	1
Deterministic jitter, fC3dB=fBAUD/1667	$U_{SATA_TXDJfB/1667}$	—	—	0.35	UI p-p	1

Note:

1. Measured at Receiver

2.24 JTAG controller

This section describes the AC electrical specifications for the IEEE 1149.1 (JTAG) interface of the device. [Table 86](#) provides the JTAG AC timing specifications as defined in [Figure 52](#) through [Figure 55](#).

2.24.1 JTAG DC electrical characteristics

This table provides the JTAG DC electrical characteristics.

Table 85. JTAG DC electrical characteristics

For recommended operating conditions, see [Table 3](#).

Parameter	Symbol	Min	Max	Unit	Note
Input high voltage	V_{IH}	2	—	V	1
Input low voltage	V_{IL}	—	0.8	V	1
Input current ($OV_{IN} = 0V$ or $OV_{IN} = OV_{DD}$)	I_{IN}	—	± 40	μA	2
Output high voltage ($OV_{DD} = \min$, $I_{OH} = -2$ mA)	V_{OH}	2.4	—	V	—
Output low voltage ($OV_{DD} = \min$, $I_{OL} = 2$ mA)	V_{OL}	—	0.4	V	—

Note:

1. Note that the min V_{IL} and max V_{IH} values are based on the respective min and max OV_{IN} values found in [Table 3](#).
2. Note that the symbol OV_{IN} represents the input voltage of the supply. It is referenced in [Table 3](#).

2.24.2 JTAG AC timing specifications

This table provides the JTAG AC timing specifications as defined in [Figure 52](#) through [Figure 55](#).

Table 86. JTAG AC timing specifications ¹

At recommended operating conditions (see [Table 3](#)).

Parameter	Symbol ²	Min	Max	Unit	Note
JTAG external clock frequency of operation	f_{JTG}	0	33.3	MHz	—
JTAG external clock cycle time	t_{JTG}	30	—	ns	—
JTAG external clock pulse width measured at 1.4V	t_{JTKHKL}	15	—	ns	—
JTAG external clock rise and fall times	t_{JTGR} & t_{JTGF}	0	2	ns	—
\overline{TRST} assert time	t_{TRST}	25	—	ns	3

Table 86. JTAG AC timing specifications (continued)¹

At recommended operating conditions (see Table 3).

Parameter	Symbol ²	Min	Max	Unit	Note
Input setup times	t_{JTDVKH}	4	—	ns	—
Input hold times	t_{JTDXKH}	10	—	ns	—
Output valid times	t_{JTKLDV}	—	10	ns	1
Output hold times	t_{JTKLDX}	0	—	ns	1

Note:

- All outputs are measured from the midpoint voltage of the falling edge of t_{TCLK} to the midpoint of the signal in question. The output timings are measured at the pins. All output timings assume a purely resistive 50- Ω load. Time-of-flight delays must be added for trace lengths, vias, and connectors in the system.
- The symbols used for timing specifications follow the pattern $t_{(\text{first two letters of functional block})(\text{signal})(\text{state})(\text{reference})(\text{state})}$ for inputs and $t_{(\text{first two letters of functional block})(\text{reference})(\text{state})(\text{signal})(\text{state})}$ for outputs. For example, t_{JTDVKH} symbolizes JTAG device timing (JT) with respect to the time data input signals (D) reaching the valid state (V) relative to the t_{JTG} clock reference (K) going to the high (H) state or setup time. Also, t_{JTDXKH} symbolizes JTAG timing (JT) with respect to the time data input signals (D) went invalid (X) relative to the t_{JTG} clock reference (K) going to the high (H) state. Note that, in general, the clock reference symbol representation is based on three letters representing the clock of a particular functional. For rise and fall times, the latter convention is used with the appropriate letter: R (rise) or F (fall).
- $\overline{\text{TRST}}$ is an asynchronous level sensitive signal. The setup time is for test purposes only.

This figure provides the AC test load for TDO and the boundary-scan outputs of the device.

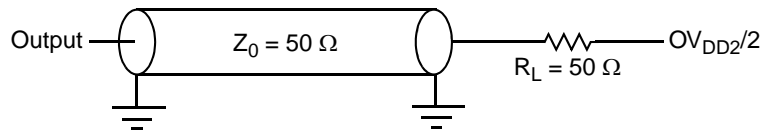
**Figure 52. AC test load for the JTAG interface**

This figure provides the JTAG clock input timing diagram.

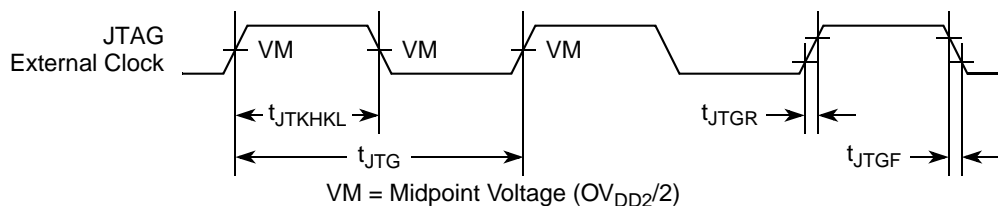
**Figure 53. JTAG clock input timing diagram**

This figure provides the $\overline{\text{TRST}}$ timing diagram.

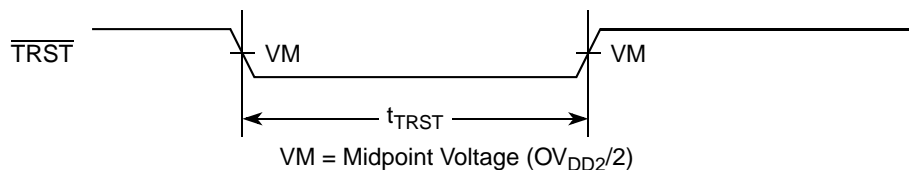
**Figure 54. $\overline{\text{TRST}}$ timing diagram**

This figure provides the boundary-scan timing diagram.

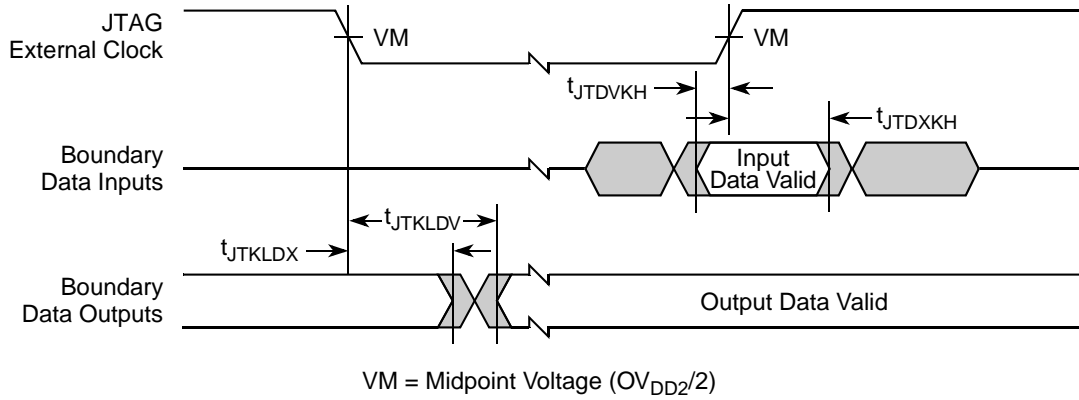

Figure 55. Boundary-scan timing diagram

3 Thermal

This section describes the thermal specifications of the device.

3.1 Thermal characteristics

This table provides the package thermal characteristics.

Table 87. Package thermal characteristics

Characteristic	JEDEC Board	Symbol	Value	Unit	Note
Junction-to-ambient Natural Convection	Single layer board (1s)	$R_{\theta JA}$	22	$^{\circ}C/W$	1, 2
Junction-to-ambient Natural Convection	Four layer board (2s2p)	$R_{\theta JA}$	17	$^{\circ}C/W$	1, 2, 3
Junction-to-ambient (at 200 ft/min)	Single layer board (1s)	$R_{\theta JA}$	16	$^{\circ}C/W$	1, 3
Junction-to-ambient (at 200 ft/min)	Four layer board (2s2p)	$R_{\theta JA}$	13	$^{\circ}C/W$	1, 3
Junction-to-board thermal	—	$R_{\theta JB}$	9	$^{\circ}C/W$	4
Junction-to-case thermal	—	$R_{\theta JC}$	6	$^{\circ}C/W$	5
Junction-to-package top thermal	Natural Convection	Ψ_{JT}	6	$^{\circ}C/W$	6

Note:

1. Junction temperature is a function of die size, on-chip power dissipation, package thermal resistance, mounting site (board) temperature, ambient temperature, air flow, power dissipation of other components on the board, and board thermal resistance.
2. Per JEDEC JESD51-2 with the single layer board horizontal. Board meets JESD51-9 specification.
3. Per JEDEC JESD51-6 with the board horizontal.
4. Thermal resistance between the die and the printed-circuit board per JEDEC JESD51-8. Board temperature is measured on the top surface of the board near the package.
5. Thermal resistance between the active surface of the die and the case top surface determined by the cold plate method (MIL SPEC-883 Method 1012.1).
6. Thermal characterization parameter indicating the temperature difference between package top and the junction temperature per JEDEC JESD51-2.

This table provides the thermal resistance with heat sink in open flow.

Table 88. Thermal resistance with heat sink in open flow

Heat Sink with Thermal Grease	Air Flow	Thermal Resistance (°C/W)
Wakefield 53 × 53 × 25 mm Pin Fin	Natural Convection	10.3
	0.5 m/s	8.3
	1 m/s	7.4
	2 m/s	7.0
	4 m/s	6.7
Aavid 35 × 31 × 23 mm Pin Fin	Natural Convection	11.7
	0.5 m/s	9.1
	1 m/s	8.3
	2 m/s	7.8
	4 m/s	7.4
Aavid 30 × 30 × 9.4 mm Pin Fin	Natural Convection	13.7
	0.5 m/s	11.2
	1 m/s	9.9
	2 m/s	8.8
	4 m/s	8.1
Aavid 43 × 41 × 16.5 mm Pin Fin	Natural Convection	12.0
	0.5 m/s	9.6
	1 m/s	8.4
	2 m/s	7.6
	4 m/s	7.1

Simulations with heat sinks were done with the package mounted on the 2s2p thermal test board. A power value of 4.5 W was used for the heat sink simulations. The thermal interface material was a typical thermal grease such as Dow Corning 340 or Wakefield 120 grease.

Simulation Details:

The 1/8 symmetry model included the following package parameters:

Four layer Substrate

Substrate solder mask thickness: 0.030 mm

Substrate metal thicknesses: 0.030mm, 0.064mm, 0.064mm, 0.030 mm

Substrate core thickness: 0.115mm, 0.100mm, 0.115 mm

Core via I.D: 0.118 mm, Core via plating 0.016 mm

Flag: trace style with ground balls under the die connected to the flag

Die Attach: 0.033 mm conductive die attach, $k = 1.5 \text{ W/m K}$

Mold Compound: generic mold compound, $k = 0.9 \text{ W/m K}$

4 Package information

This section provides the package parameters and ordering information.

4.1 Package parameters for the P1013WB-TePBGA II

The package parameters are provided in the following list. The package type is 31 mm × 31 mm, 689 plastic ball grid array (WB-TePBGA).

Package outline	31 mm × 31 mm
Interconnects	689
Pitch	1.00 mm
Module height (typical)	2.0 mm to 2.46 mm (Maximum)
Solder Balls	3.5% Ag, 96.5% Sn
Ball diameter (typical)	0.60 mm



Figure 56. P1013 package

Notes:

1. All dimensions are in millimeters.
2. Dimensioning and tolerancing per ASME Y14. 5M-1994.
3. Maximum solder ball diameter measured parallel to Datum A.
4. Datum A, the seating plane, is determined by the spherical crowns of the solder balls.
5. Parallelism measurement shall exclude any effect of mark on top surface of package.

4.2 Ordering information

This table provides the Freescale part numbering nomenclature for the P1013. Each part number also contains a revision code which refers to the die mask revision number.

Table 89. P1013 part numbers

P	1	01	3	q	t	e	n	dd	r
Generation	Platform	Number of cores	Derivative	Qualification status	Temperature range	Encryption	Package type	CPU/CCB/DDR frequency (MHz)	Silicon revision
P = 45nm	1–5	01 = Single Core 02 = Dual Core	0–9	P = Prototype N = Qualified to industrial tier S = Special	S = Std temp X = Ext temp	E = SEC present N = SEC Not present	2 = TEPBGAll Pbfree	EF=600/400/667 HF=800/400/667 LF=1067/533/667 MH=1200/480/800	A = 1.0 B = 1.1

Note:

1. See [Section 4, “Package information,”](#) for more information on available package types.
2. Processor core frequencies supported by parts addressed by this specification only. Not all parts described in this specification support all core frequencies. Additionally, parts addressed by part number specifications may support other maximum core frequencies.
- 3) Extended temperature range only supported for DDR3
- 4) Only standard temperature range is supported for 1200MHz CPU

4.3 Part marking

Parts are marked as the example shown in this figure.

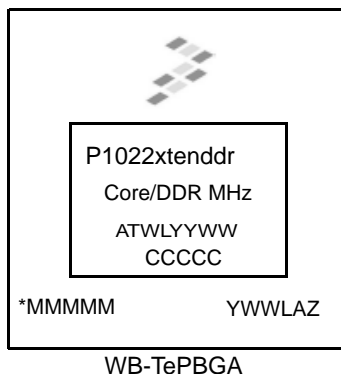

Notes:

- P1022xtenddr is the orderable part number
- *MMMMM is the mask number
- YWWLAZ is the assembly traceability code.
- CCCCC is the country code
- ATWLYYWW is the standard assembly, test, year, and work week codes.

Figure 57. Part marking for WB-TePBGA II device

5 Product documentation

This data sheet is labeled as a particular type: Product Preview, Advance Information, or Technical Data. Definitions of these types are available at: <http://www.freescale.com>.

The following documents are required for a complete description of the device and are needed to design properly with the part:

- *P1022 QorIQ Integrated Processor Reference Manual* (document number P1022RM)
- *e500 PowerPC Core Family Reference Manual* (E500CORERM)

6 Revision history

This table summarizes a revision history for this document.

Table 90. Revision history

Rev. Number	Date	Substantive Change(s)
2	09/2013	<ul style="list-style-type: none"> • In page 1, deleted the bulleted item: Operating junction temperature (Tj) range: 0–125°C and –40°C to 125°C (industrial specification). • In Table 3, “Recommended Operating Conditions”, modified Junction temperature range to Operational temperature range. • In Table 2 and Table 3, updated the SV_{DD} and XV_{DD} description . Added SV_{DD} to Figure 7. • Removed Note 1 Caution below Table 3 and Updated Note 8 below Table 2. • In Table 5, updated HOLD time and Valid to High impedance spec. • Updated Note 7 below Table 9. • Replaced TSEC_1588_TRIG_OUT with TSEC_1588_ALARM_OUT and added TSEC_1588_ALARM_OUT to Table 38. • Added 1200MHz part to Table 89. • Added 1200MHz part specification to Table 2, Table 3, Table 8 and Table 9. • Added AC characteristics for 800MT/s DDR3. • Rephrased note 12 below Table 8. • In Section 2.2, “Power sequencing”, added note for relaxing sequencing requirement for serdes supplies. • In Table 52, updated tLBONOT minimum value to 1 and removed the max value. • Changed value of minimum AC coupling capacitor from 5nF to 10nF and removed typical value of 100nF in Table 42. • In Table 43, changed “LSTS = 0” to “LSTS = 001” and “LSTS = 1” to “LSTS = 100”. • In Table 43, changed note 4 to “The LSTS shown in the table refers to the EIC0[0:2] or EIC1[0:2] bit field of P1013’s SerDes2 Control Register 3 and EIC2[0:2] or EIC3[0:2] bit field of P1013’s SerDes1 Control Register 4”. • Updated Note 3 below Table 41. • Modified Figure 18. • Updated MHz data rate for DDR3 to MT/s data rate throughout the document.
1	05/2012	Updated the note numbers in Table 1 .
0	11/2011	Initial release

How to Reach Us:

Home Page:

www.freescale.com

Web Support:

<http://www.freescale.com/support>

Information in this document is provided solely to enable system and software implementers to use Freescale products. There are no express or implied copyright licenses granted hereunder to design or fabricate any integrated circuits based on the information in this document.

Freescale reserves the right to make changes without further notice to any products herein. Freescale makes no warranty, representation, or guarantee regarding the suitability of its products for any particular purpose, nor does Freescale assume any liability arising out of the application or use of any product or circuit, and specifically disclaims any and all liability, including without limitation consequential or incidental damages. "Typical" parameters that may be provided in Freescale data sheets and/or specifications can and do vary in different applications, and actual performance may vary over time. All operating parameters, including "typicals," must be validated for each customer application by customer's technical experts. Freescale does not convey any license under its patent rights nor the rights of others. Freescale sells products pursuant to standard terms and conditions of sale, which can be found at the following address: freescale.com/SalesTermsandConditions.

Freescale, the Freescale logo, CodeWarrior, ColdFire, EPowerQUICC, QorIQ, StarCore, Symphony, and VortiQa are trademarks of Freescale Semiconductor, Inc., Reg. U.S. Pat. & Tm. Off. CoreNet, and QUICC Engine are trademarks of Freescale Semiconductor, Inc. All other product or service names are the property of their respective owners. The Power Architecture and Power.org word marks and the Power and Power.org logos and related marks are trademarks and service marks licensed by Power.org.

© 2011-2013 Freescale Semiconductor, Inc.

Document Number: P1013EC
Rev. 2, 9/2013



X-ON Electronics

Largest Supplier of Electrical and Electronic Components

Click to view similar products for [Microprocessors - MPU category](#):

Click to view products by [NXP manufacturer](#):

Other Similar products are found below :

[A2C00010998 A](#) [ALXD800EEXJCVD C3](#) [A2C00010729 A](#) [TS68040MF33A](#) [BOXSTCK1A8LFCL](#) [UPD78F0503AMCA-CAB-G](#)
[Z8018008VEG](#) [T1024NXN7MQA](#) [T2080NXE8PTB](#) [T2080NSE8PTB](#) [T1024NXE7MQA](#) [CM8063501521600S R19L](#) [T2080NXE8T1B](#)
[LS1043AXE7MQB](#) [LS1043ASE7QQB](#) [LS1012AXE7HKA](#) [T4240NSN7PQB](#) [MVF30NN152CKU26](#) [FH8067303534005S R3ZM](#)
[R9A07G044L24GBG#AC0](#) [HW8076502640002S R38F](#) [R7S721030VLFP#AA0](#) [MCIMX6U5DVM10AC](#) [TEN54LSDV23GME](#)
[MPC8314VRAGDA](#) [MPC8315VRAGDA](#) [PIC16F1828-I/SS](#) [PIC16F690T-I/SS](#) [PIC16F1823-I/SL](#) [PIC18LF14K50-I/SS](#) [LS1021AXN7HNB](#)
[AT91SAM9XE256-CU](#) [NS7520B-1-I46](#) [AT91SAM9G35-CU](#) [AT91SAM9X25-CU](#) [ST7FLIT35F2DAKTR](#) [Z84C0006PEG](#) [AM1808EZWT4](#)
[MPC8347CVRADDB](#) [MCIMX6V7DVN10AB](#) [LS1043ASN7PQB](#) [GD32F303RCT6](#) [MPC5121YVY400B](#) [SMS3700HAX4DQE](#)
[ADD4200IAA5DOE](#) [ST7PLITE05OBXTR](#) [AT91RM9200-CJ-002](#) [AT91RM9200-QU-002](#) [AT91SAM9CN12B-CFU](#) [AT91SAM9G20B-CFU](#)