



PCF8563

Real-time clock/calendar

Rev. 11 — 26 October 2015

Product data sheet

1. General description

The PCF8563 is a CMOS¹ Real-Time Clock (RTC) and calendar optimized for low power consumption. A programmable clock output, interrupt output, and voltage-low detector are also provided. All addresses and data are transferred serially via a two-line bidirectional I²C-bus. Maximum bus speed is 400 kbit/s. The register address is incremented automatically after each written or read data byte.

2. Features and benefits

- Provides year, month, day, weekday, hours, minutes, and seconds based on a 32.768 kHz quartz crystal
- Century flag
- Clock operating voltage: 1.0 V to 5.5 V at room temperature
- Low backup current; typical 0.25 μ A at $V_{DD} = 3.0$ V and $T_{amb} = 25$ °C
- 400 kHz two-wire I²C-bus interface (at $V_{DD} = 1.8$ V to 5.5 V)
- Programmable clock output for peripheral devices (32.768 kHz, 1.024 kHz, 32 Hz, and 1 Hz)
- Alarm and timer functions
- Integrated oscillator capacitor
- Internal Power-On Reset (POR)
- I²C-bus slave address: read A3h and write A2h
- Open-drain interrupt pin

3. Applications

- Mobile telephones
- Portable instruments
- Electronic metering
- Battery powered products

1. The definition of the abbreviations and acronyms used in this data sheet can be found in [Section 18](#).



4. Ordering information

Table 1. Ordering information

Type number	Package		
	Name	Description	Version
PCF8563BS/4	HVSON10	plastic thermal enhanced very thin small outline package; no leads; 10 terminals; body 3 × 3 × 0.85 mm	SOT650-1
PCF8563T/5	SO8	plastic small outline package; 8 leads; body width 3.9 mm	SOT96-1
PCF8563T/F4 ^[1]	SO8	plastic small outline package; 8 leads; body width 3.9 mm	SOT96-1
PCF8563TS/4 ^[2]	TSSOP8	plastic thin shrink small outline package; 8 leads; body width 3 mm	SOT505-1
PCF8563TS/5	TSSOP8	plastic thin shrink small outline package; 8 leads; body width 3 mm	SOT505-1

[1] Not recommended for new designs. Replacement part is PCF8563T/5.

[2] Not recommended for new designs. Replacement part is PCF8563TS/5.

5. Marking

Table 2. Marking codes

Type number	Marking code
PCF8563BS/4	8563S
PCF8563T/5	PCF8563
PCF8563T/F4	8563T
PCF8563TS/4	8563
PCF8563TS/5	P8563

6. Block diagram

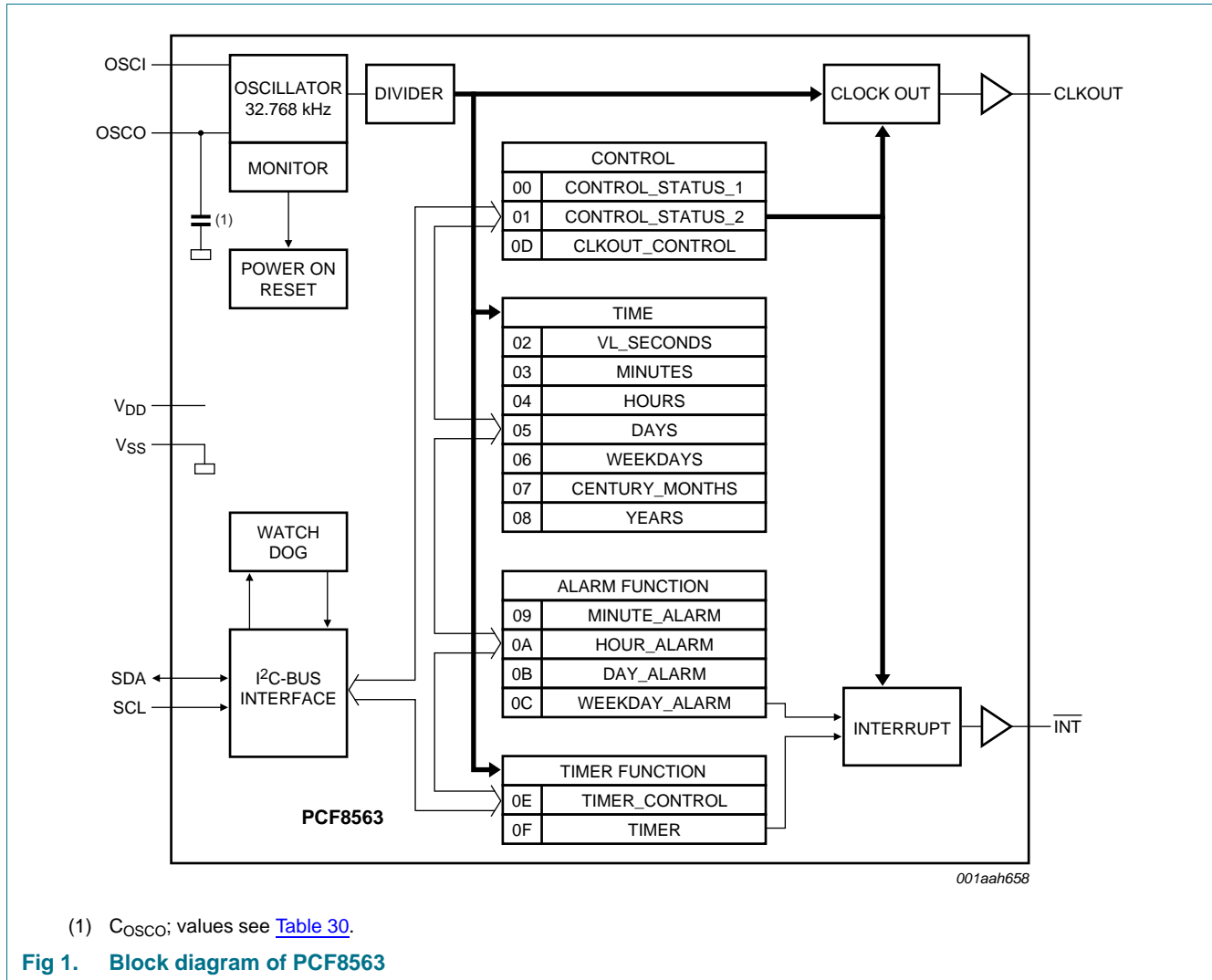

7. Pinning information

7.1 Pinning

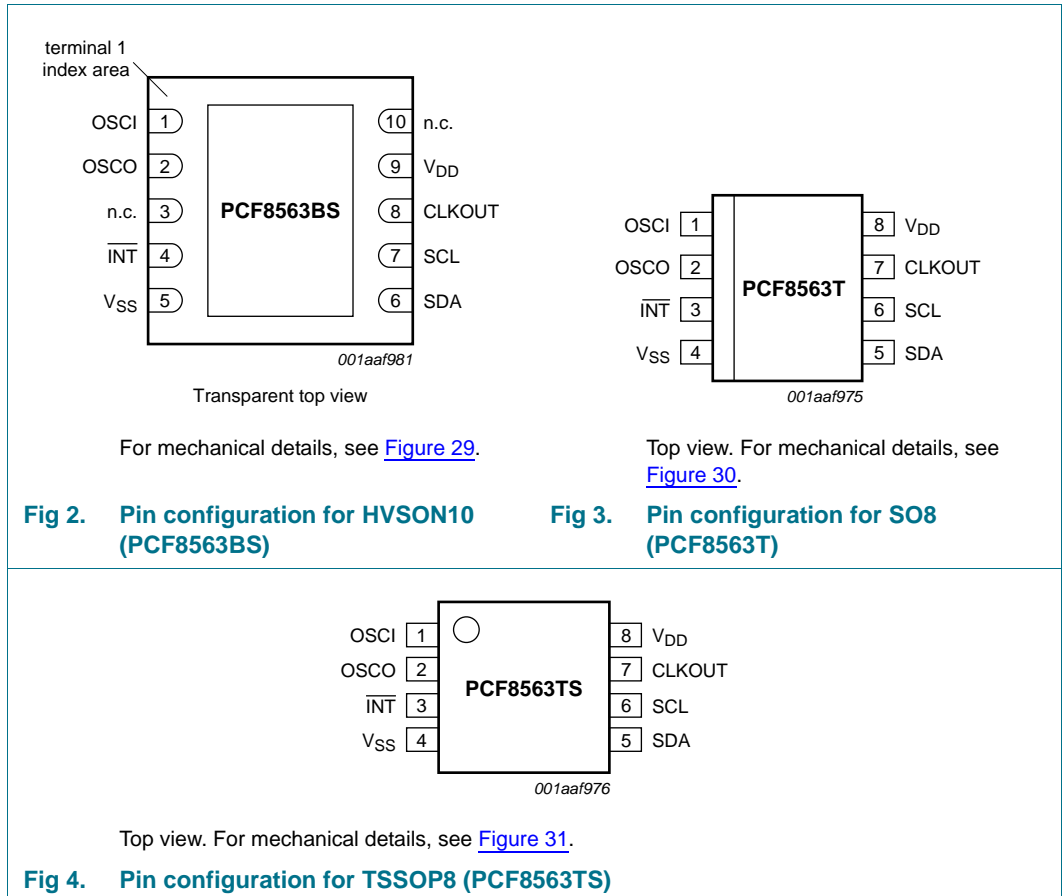

7.2 Pin description

Table 3. Pin description

Symbol	Pin		Description
	SO8, TSSOP8	HVSON10	
OSCI	1	1	oscillator input
OSCO	2	2	oscillator output
$\overline{\text{INT}}$	3	4	interrupt output (open-drain; active LOW)
V_{SS}	4	5 ^[1]	ground
SDA	5	6	serial data input and output
SCL	6	7	serial clock input
CLKOUT	7	8	clock output, open-drain
V_{DD}	8	9	supply voltage
n.c.	-	3, 10	not connected; do not connect and do not use as feed through

- [1] The die paddle (exposed pad) is connected to V_{SS} through high ohmic (non-conductive) silicon attach and should be electrically isolated. It is good engineering practice to solder the exposed pad to an electrically isolated PCB copper pad for better heat transfer but it is not required as the RTC doesn't consume much power. In no case should traces be run under the package exposed pad.

8. Functional description

The PCF8563 contains sixteen 8-bit registers with an auto-incrementing register address, an on-chip 32.768 kHz oscillator with one integrated capacitor, a frequency divider which provides the source clock for the Real-Time Clock (RTC) and calendar, a programmable clock output, a timer, an alarm, a voltage-low detector, and a 400 kHz I²C-bus interface.

All 16 registers are designed as addressable 8-bit parallel registers although not all bits are implemented. The first two registers (memory address 00h and 01h) are used as control and/or status registers. The memory addresses 02h through 08h are used as counters for the clock function (seconds up to years counters). Address locations 09h through 0Ch contain alarm registers which define the conditions for an alarm. Address 0Dh controls the CLKOUT output frequency. 0Eh and 0Fh are the Timer_control and Timer registers, respectively.

The Seconds, Minutes, Hours, Days, Months, Years as well as the Minute_alarm, Hour_alarm, and Day_alarm registers are all coded in Binary Coded Decimal (BCD) format.

When one of the RTC registers is written or read, the contents of all time counters are frozen. Therefore, faulty writing or reading of the clock and calendar during a carry condition is prevented.

8.1 CLKOUT output

A programmable square wave is available at the CLKOUT pin. Operation is controlled by the register CLKOUT_control at address 0Dh. Frequencies of 32.768 kHz (default), 1.024 kHz, 32 Hz, and 1 Hz can be generated for use as a system clock, microcontroller clock, input to a charge pump, or for calibration of the oscillator. CLKOUT is an open-drain output and enabled at power-on. If disabled it becomes high-impedance.

8.2 Register organization

Table 4. Formatted registers overview

Bit positions labelled as x are not relevant. Bit positions labelled with N should always be written with logic 0; if read they could be either logic 0 or logic 1. After reset, all registers are set according to [Table 27](#).

Address	Register name	Bit							
		7	6	5	4	3	2	1	0
Control and status registers									
00h	Control_status_1	TEST1	N	STOP	N	TESTC	N	N	N
01h	Control_status_2	N	N	N	TI_TP	AF	TF	AIE	TIE
Time and date registers									
02h	VL_seconds	VL	SECONDS (0 to 59)						
03h	Minutes	x	MINUTES (0 to 59)						
04h	Hours	x	x	HOURS (0 to 23)					
05h	Days	x	x	DAYS (1 to 31)					
06h	Weekdays	x	x	x	x	x	WEEKDAYS (0 to 6)		
07h	Century_months	C	x	x	MONTHS (1 to 12)				
08h	Years	YEARS (0 to 99)							

Table 4. Formatted registers overview ...continued

Bit positions labelled as x are not relevant. Bit positions labelled with N should always be written with logic 0; if read they could be either logic 0 or logic 1. After reset, all registers are set according to [Table 27](#).

Address	Register name	Bit							
		7	6	5	4	3	2	1	0
Alarm registers									
09h	Minute_alarm	AE_M	MINUTE_ALARM (0 to 59)						
0Ah	Hour_alarm	AE_H	x	HOUR_ALARM (0 to 23)					
0Bh	Day_alarm	AE_D	x	DAY_ALARM (1 to 31)					
0Ch	Weekday_alarm	AE_W	x	x	x	x	WEEKDAY_ALARM (0 to 6)		
CLKOUT control register									
0Dh	CLKOUT_control	FE	x	x	x	x	x	FD[1:0]	
Timer registers									
0Eh	Timer_control	TE	x	x	x	x	x	TD[1:0]	
0Fh	Timer	TIMER[7:0]							

8.3 Control registers

8.3.1 Register Control_status_1

Table 5. Control_status_1 - control and status register 1 (address 00h) bit description

Bit	Symbol	Value	Description	Reference
7	TEST1	0 ^[1]	normal mode must be set to logic 0 during normal operations	Section 8.9
		1	EXT_CLK test mode	
6	N	0 ^[2]	unused	
5	STOP	0 ^[1]	RTC source clock runs	Section 8.10
		1	all RTC divider chain flip-flops are asynchronously set to logic 0; the RTC clock is stopped (CLKOUT at 32.768 kHz is still available)	
4	N	0 ^[2]	unused	
3	TESTC	0	Power-On Reset (POR) override facility is disabled; set to logic 0 for normal operation	Section 8.11.1
		1 ^[1]	Power-On Reset (POR) override may be enabled	
2 to 0	N	000 ^[2]	unused	

[1] Default value.

[2] Bits labeled as N should always be written with logic 0.

8.3.2 Register Control_status_2

Table 6. Control_status_2 - control and status register 2 (address 01h) bit description

Bit	Symbol	Value	Description	Reference
7 to 5	N	000 ^[1]	unused	
4	TI_TP	0 ^[2]	$\overline{\text{INT}}$ is active when TF is active (subject to the status of TIE)	Section 8.3.2.1 and Section 8.8
		1	$\overline{\text{INT}}$ pulses active according to Table 7 (subject to the status of TIE); Remark: note that if AF and AIE are active then $\overline{\text{INT}}$ will be permanently active	

Table 6. Control_status_2 - control and status register 2 (address 01h) bit description ...continued

Bit	Symbol	Value	Description	Reference
3	AF	0 ^[2]	read: alarm flag inactive	Section 8.3.2.1
			write: alarm flag is cleared	
		1	read: alarm flag active	
			write: alarm flag remains unchanged	
2	TF	0 ^[2]	read: timer flag inactive	
			write: timer flag is cleared	
		1	read: timer flag active	
			write: timer flag remains unchanged	
1	AIE	0 ^[2]	alarm interrupt disabled	
		1	alarm interrupt enabled	
0	TIE	0 ^[2]	timer interrupt disabled	
		1	timer interrupt enabled	

[1] Bits labeled as N should always be written with logic 0.

[2] Default value.

8.3.2.1 Interrupt output

Bits TF and AF: When an alarm occurs, AF is set to logic 1. Similarly, at the end of a timer countdown, TF is set to logic 1. These bits maintain their value until overwritten using the interface. If both timer and alarm interrupts are required in the application, the source of the interrupt can be determined by reading these bits. To prevent one flag being overwritten while clearing another, a logic AND is performed during a write access.

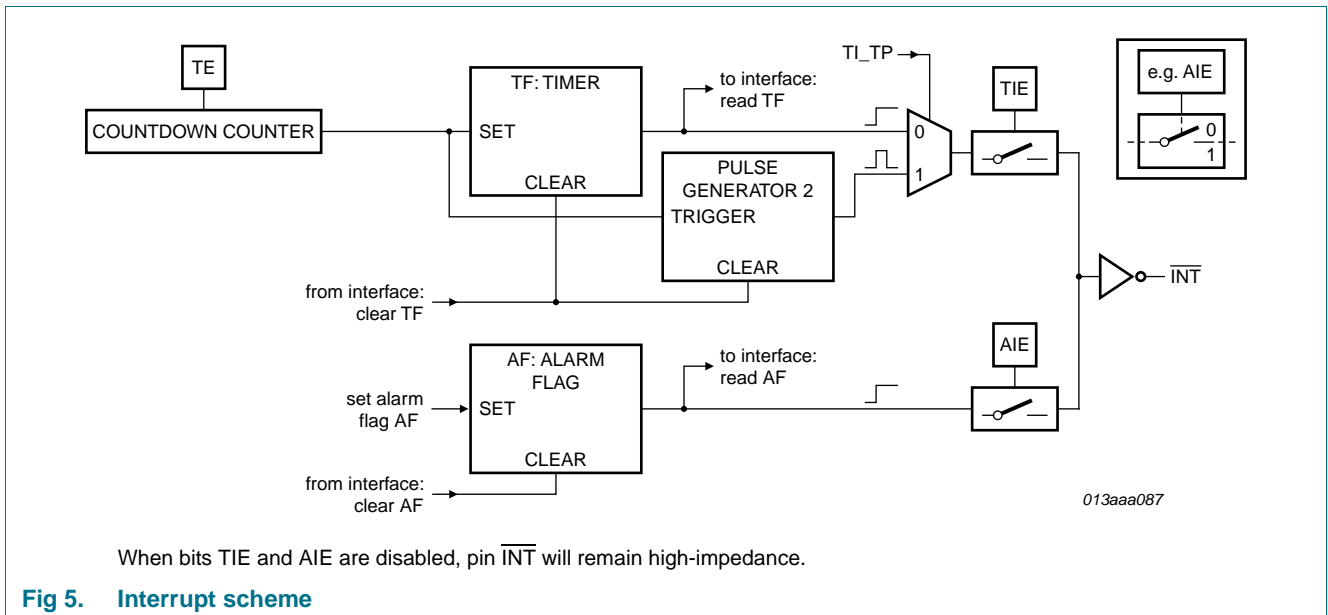

When bits TIE and AIE are disabled, pin \overline{INT} will remain high-impedance.

Fig 5. Interrupt scheme

Bits TIE and AIE: These bits activate or deactivate the generation of an interrupt when TF or AF is asserted, respectively. The interrupt is the logical OR of these two conditions when both AIE and TIE are set.

Countdown timer interrupts: The pulse generator for the countdown timer interrupt uses an internal clock and is dependent on the selected source clock for the countdown timer and on the countdown value n . As a consequence, the width of the interrupt pulse varies (see [Table 7](#)).

Table 7. $\overline{\text{INT}}$ operation (bit $\text{TI_TP} = 1$)^[1]

Source clock (Hz)	$\overline{\text{INT}}$ period (s)	
	$n = 1$ ^[2]	$n > 1$ ^[2]
4096	$\frac{1}{8192}$	$\frac{1}{4096}$
64	$\frac{1}{128}$	$\frac{1}{64}$
1	$\frac{1}{64}$	$\frac{1}{64}$
$\frac{1}{60}$	$\frac{1}{64}$	$\frac{1}{64}$

[1] TF and $\overline{\text{INT}}$ become active simultaneously.

[2] n = loaded countdown value. Timer stops when $n = 0$.

8.4 Time and date registers

The majority of the registers are coded in the BCD format to simplify application use.

8.4.1 Register VL_seconds

Table 8. VL_seconds - seconds and clock integrity status register (address 02h) bit description

Bit	Symbol	Value	Place value	Description
7	VL	0	-	clock integrity is guaranteed
		1 ^[1]	-	integrity of the clock information is not guaranteed
6 to 4	SECONDS	0 to 5	ten's place	actual seconds coded in BCD format, see Table 9
3 to 0		0 to 9	unit place	

[1] Start-up value.

Table 9. Seconds coded in BCD format

Seconds value (decimal)	Upper-digit (ten's place)			Digit (unit place)			
	Bit 6	Bit 5	Bit 4	Bit 3	Bit 2	Bit 1	Bit 0
00	0	0	0	0	0	0	0
01	0	0	0	0	0	0	1
02	0	0	0	0	0	1	0
:	:	:	:	:	:	:	:
09	0	0	0	1	0	0	1
10	0	0	1	0	0	0	0
:	:	:	:	:	:	:	:
58	1	0	1	1	0	0	0
59	1	0	1	1	0	0	1

8.4.1.1 Voltage-low detector and clock monitor

The PCF8563 has an on-chip voltage-low detector (see Figure 6). When V_{DD} drops below V_{low} , bit VL in the VL_seconds register is set to indicate that the integrity of the clock information is no longer guaranteed. The VL flag can only be cleared by using the interface.

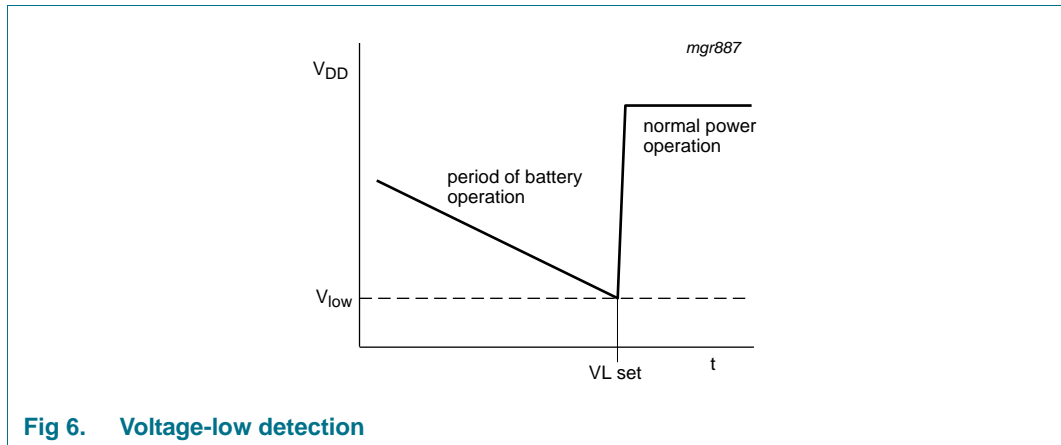

The VL flag is intended to detect the situation when V_{DD} is decreasing slowly, for example under battery operation. Should the oscillator stop or V_{DD} reach V_{low} before power is re-asserted, then the VL flag is set. This will indicate that the time may be corrupted.

8.4.2 Register Minutes

Table 10. Minutes - minutes register (address 03h) bit description

Bit	Symbol	Value	Place value	Description
7	-	-	-	unused
6 to 4	MINUTES	0 to 5	ten's place	actual minutes coded in BCD format
3 to 0		0 to 9	unit place	

8.4.3 Register Hours

Table 11. Hours - hours register (address 04h) bit description

Bit	Symbol	Value	Place value	Description
7 to 6	-	-	-	unused
5 to 4	HOURS	0 to 2	ten's place	actual hours coded in BCD format
3 to 0		0 to 9	unit place	

8.4.4 Register Days

Table 12. Days - days register (address 05h) bit description

Bit	Symbol	Value	Place value	Description
7 to 6	-	-	-	unused
5 to 4	DAYS ^[1]	0 to 3	ten's place	actual day coded in BCD format
3 to 0		0 to 9	unit place	

[1] The PCF8563 compensates for leap years by adding a 29th day to February if the year counter contains a value which is exactly divisible by 4, including the year 00.

8.4.5 Register Weekdays

Table 13. Weekdays - weekdays register (address 06h) bit description

Bit	Symbol	Value	Description
7 to 3	-	-	unused
2 to 0	WEEKDAYS	0 to 6	actual weekday values, see Table 14

Table 14. Weekday assignments

Day ^[1]	Bit		
	2	1	0
Sunday	0	0	0
Monday	0	0	1
Tuesday	0	1	0
Wednesday	0	1	1
Thursday	1	0	0
Friday	1	0	1
Saturday	1	1	0

[1] Definition may be re-assigned by the user.

8.4.6 Register Century_months

Table 15. Century_months - century flag and months register (address 07h) bit description

Bit	Symbol	Value	Place value	Description
7	C ^[1]	0 ^[2]	-	indicates the century is x
		1	-	indicates the century is x + 1
6 to 5	-	-	-	unused
4	MONTHS	0 to 1	ten's place	actual month coded in BCD format, see Table 16
3 to 0		0 to 9	unit place	

[1] This bit may be re-assigned by the user.

[2] This bit is toggled when the register Years overflows from 99 to 00.

Table 16. Month assignments in BCD format

Month	Upper-digit (ten's place)	Digit (unit place)			
	Bit 4	Bit 3	Bit 2	Bit 1	Bit 0
January	0	0	0	0	1
February	0	0	0	1	0
March	0	0	0	1	1
April	0	0	1	0	0
May	0	0	1	0	1
June	0	0	1	1	0
July	0	0	1	1	1
August	0	1	0	0	0
September	0	1	0	0	1

Table 16. Month assignments ...continued in BCD format

Month	Upper-digit (ten's place)	Digit (unit place)			
	Bit 4	Bit 3	Bit 2	Bit 1	Bit 0
October	1	0	0	0	0
November	1	0	0	0	1
December	1	0	0	1	0

8.4.7 Register Years

Table 17. Years - years register (08h) bit description

Bit	Symbol	Value	Place value	Description
7 to 4	YEARS	0 to 9	ten's place	actual year coded in BCD format ^[1]
3 to 0		0 to 9	unit place	

[1] When the register Years overflows from 99 to 00, the century bit C in the register Century_months is toggled.

8.5 Setting and reading the time

Figure 7 shows the data flow and data dependencies starting from the 1 Hz clock tick.

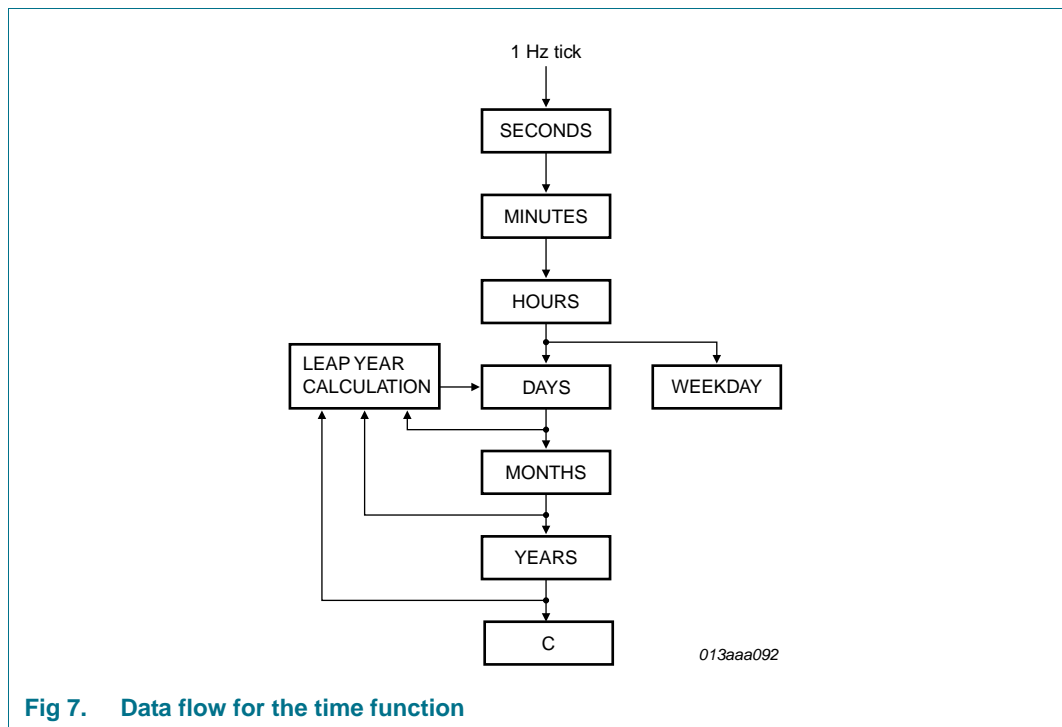

Fig 7. Data flow for the time function

During read/write operations, the time counting circuits (memory locations 02h through 08h) are blocked.

This prevents

- Faulty reading of the clock and calendar during a carry condition
- Incrementing the time registers, during the read cycle

After this read/write access is completed, the time circuit is released again and any pending request to increment the time counters that occurred during the read access is serviced. A maximum of 1 request can be stored; therefore, all accesses must be completed within 1 second (see [Figure 8](#)).

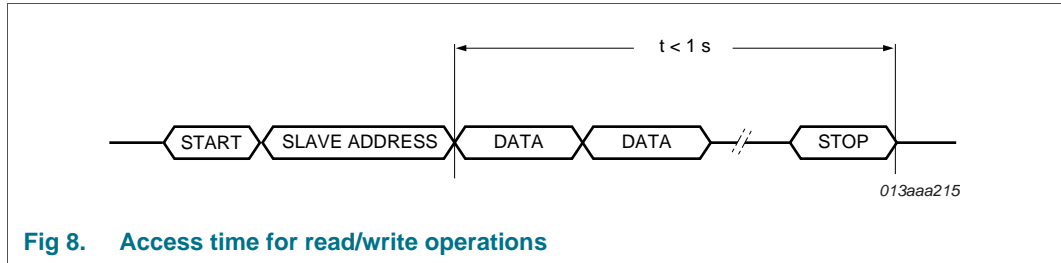

Fig 8. Access time for read/write operations

As a consequence of this method, it is very important to make a read or write access in one go, that is, setting or reading seconds through to years should be made in one single access. Failing to comply with this method could result in the time becoming corrupted.

As an example, if the time (seconds through to hours) is set in one access and then in a second access the date is set, it is possible that the time may increment between the two accesses. A similar problem exists when reading. A roll over may occur between reads thus giving the minutes from one moment and the hours from the next.

Recommended method for reading the time:

1. Send a START condition and the slave address for write (A2h).
2. Set the address pointer to 2 (VL_seconds) by sending 02h.
3. Send a RESTART condition or STOP followed by START.
4. Send the slave address for read (A3h).
5. Read VL_seconds.
6. Read Minutes.
7. Read Hours.
8. Read Days.
9. Read Weekdays.
10. Read Century_months.
11. Read Years.
12. Send a STOP condition.

8.6 Alarm registers

8.6.1 Register Minute_alarm

Table 18. Minute_alarm - minute alarm register (address 09h) bit description

Bit	Symbol	Value	Place value	Description
7	AE_M	0	-	minute alarm is enabled
		1 ^[1]	-	minute alarm is disabled
6 to 4	MINUTE_ALARM	0 to 5	ten's place	minute alarm information coded in BCD format
3 to 0		0 to 9	unit place	

[1] Default value.

8.6.2 Register Hour_alarm

Table 19. Hour_alarm - hour alarm register (address 0Ah) bit description

Bit	Symbol	Value	Place value	Description
7	AE_H	0	-	hour alarm is enabled
		1 ^[1]	-	hour alarm is disabled
6	-	-	-	unused
5 to 4	HOUR_ALARM	0 to 2	ten's place	hour alarm information coded in BCD format
3 to 0		0 to 9	unit place	

[1] Default value.

8.6.3 Register Day_alarm

Table 20. Day_alarm - day alarm register (address 0Bh) bit description

Bit	Symbol	Value	Place value	Description
7	AE_D	0	-	day alarm is enabled
		1 ^[1]	-	day alarm is disabled
6	-	-	-	unused
5 to 4	DAY_ALARM	0 to 3	ten's place	day alarm information coded in BCD format
3 to 0		0 to 9	unit place	

[1] Default value.

8.6.4 Register Weekday_alarm

Table 21. Weekday_alarm - weekday alarm register (address 0Ch) bit description

Bit	Symbol	Value	Description
7	AE_W	0	weekday alarm is enabled
		1 ^[1]	weekday alarm is disabled
6 to 3	-	-	unused
2 to 0	WEEKDAY_ALARM	0 to 6	weekday alarm information

[1] Default value.

8.6.5 Alarm flag

By clearing the alarm enable bit (AE_x) of one or more of the alarm registers, the corresponding alarm condition(s) are active. When an alarm occurs, AF is set to logic 1. The asserted AF can be used to generate an interrupt ($\overline{\text{INT}}$). The AF is cleared using the interface.

The registers at addresses 09h through 0Ch contain alarm information. When one or more of these registers is loaded with minute, hour, day or weekday, and its corresponding AE_x is logic 0, then that information is compared with the current minute, hour, day, and weekday. When all enabled comparisons first match, the alarm flag (AF in register Control_2) is set to logic 1.

The generation of interrupts from the alarm function is controlled via bit AIE. If bit AIE is enabled, the $\overline{\text{INT}}$ pin follows the condition of bit AF. AF will remain set until cleared by the interface. Once AF has been cleared, it will only be set again when the time increments to match the alarm condition once more. Alarm registers which have their AE_x bit at logic 1 are ignored.

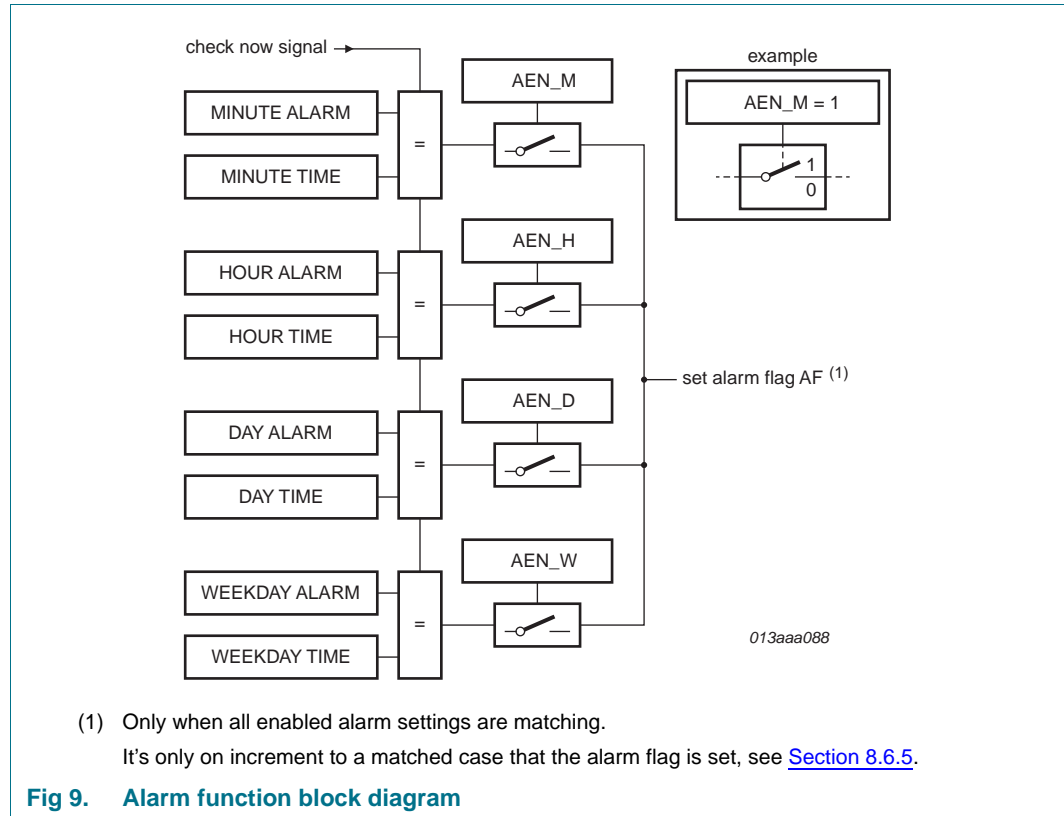

8.7 Register CLKOUT_control and clock output

Frequencies of 32.768 kHz (default), 1.024 kHz, 32 Hz, and 1 Hz can be generated for use as a system clock, microcontroller clock, input to a charge pump, or for calibration of the oscillator.

Table 22. CLKOUT_control - CLKOUT control register (address 0Dh) bit description

Bit	Symbol	Value	Description
7	FE	0	the CLKOUT output is inhibited and CLKOUT output is set high-impedance
		1 ^[1]	the CLKOUT output is activated
6 to 2	-	-	unused
1 to 0	FD[1:0]		frequency output at pin CLKOUT
		00 ^[1]	32.768 kHz
		01	1.024 kHz
		10	32 Hz
		11	1 Hz

[1] Default value.

8.8 Timer function

The 8-bit countdown timer at address 0Fh is controlled by the Timer_control register at address 0Eh. The Timer_control register determines one of 4 source clock frequencies for the timer (4096 Hz, 64 Hz, 1 Hz, or 1/60 Hz), and enables or disables the timer. The timer counts down from a software-loaded 8-bit binary value. At the end of every countdown, the timer sets the timer flag TF. The TF may only be cleared by using the interface. The asserted TF can be used to generate an interrupt on pin INT. The interrupt may be generated as a pulsed signal every countdown period or as a permanently active signal which follows the state of TF. Bit TI_TP is used to control this mode selection. When reading the timer, the current countdown value is returned.

8.8.1 Register Timer_control

Table 23. Timer_control - timer control register (address 0Eh) bit description

Bit	Symbol	Value	Description
7	TE	0 ^[1]	timer is disabled
		1	timer is enabled
6 to 2	-	-	unused
1 to 0	TD[1:0]		timer source clock frequency select ^[2]
		00	4.096 kHz
		01	64 Hz
		10	1 Hz
		11 ^[2]	1/60 Hz

[1] Default value.

[2] These bits determine the source clock for the countdown timer; when not in use, TD[1:0] should be set to 1/60 Hz for power saving.

8.8.2 Register Timer

Table 24. Timer - timer value register (address 0Fh) bit description

Bit	Symbol	Value	Description
7 to 0	TIMER[7:0]	00h to FFh	countdown period in seconds: $CountdownPeriod = \frac{n}{SourceClockFrequency}$ where n is the countdown value

Table 25. Timer register bits value range

Bit							
7	6	5	4	3	2	1	0
128	64	32	16	8	4	2	1

The register Timer is an 8-bit binary countdown timer. It is enabled and disabled via the Timer_control register bit TE. The source clock for the timer is also selected by the Timer_control register. Other timer properties such as interrupt generation are controlled via the register Control_status_2.

For accurate read back of the count down value, it is recommended to read the register twice and check for consistent results, since it is not possible to freeze the countdown timer counter during read back.

8.9 EXT_CLK test mode

A test mode is available which allows for on-board testing. In such a mode it is possible to set up test conditions and control the operation of the RTC.

The test mode is entered by setting bit TEST1 in register Control_status_1. Then pin CLKOUT becomes an input. The test mode replaces the internal 64 Hz signal with the signal applied to pin CLKOUT. Every 64 positive edges applied to pin CLKOUT will then generate an increment of one second.

The signal applied to pin CLKOUT should have a minimum pulse width of 300 ns and a maximum period of 1000 ns. The internal 64 Hz clock, now sourced from CLKOUT, is divided down to 1 Hz by a 2^6 divide chain called a prescaler. The prescaler can be set into a known state by using bit STOP. When bit STOP is set, the prescaler is reset to 0 (STOP must be cleared before the prescaler can operate again).

From a STOP condition, the first 1 second increment will take place after 32 positive edges on CLKOUT. Thereafter, every 64 positive edges will cause a one-second increment.

Remark: Entry into EXT_CLK test mode is not synchronized to the internal 64 Hz clock. When entering the test mode, no assumption as to the state of the prescaler can be made.

8.9.1 Operation example:

1. Set EXT_CLK test mode (Control_status_1, bit TEST1 = 1).
2. Set STOP (Control_status_1, bit STOP = 1).
3. Clear STOP (Control_status_1, bit STOP = 0).
4. Set time registers to desired value.
5. Apply 32 clock pulses to CLKOUT.
6. Read time registers to see the first change.
7. Apply 64 clock pulses to CLKOUT.
8. Read time registers to see the second change.

Repeat steps 7 and 8 for additional increments.

8.10 STOP bit function

The function of the STOP bit is to allow for accurate starting of the time circuits. The STOP bit function will cause the upper part of the prescaler (F₂ to F₁₄) to be held in reset and thus no 1 Hz ticks will be generated (see Figure 10). The time circuits can then be set and will not increment until the STOP bit is released (see Figure 11 and Table 26).

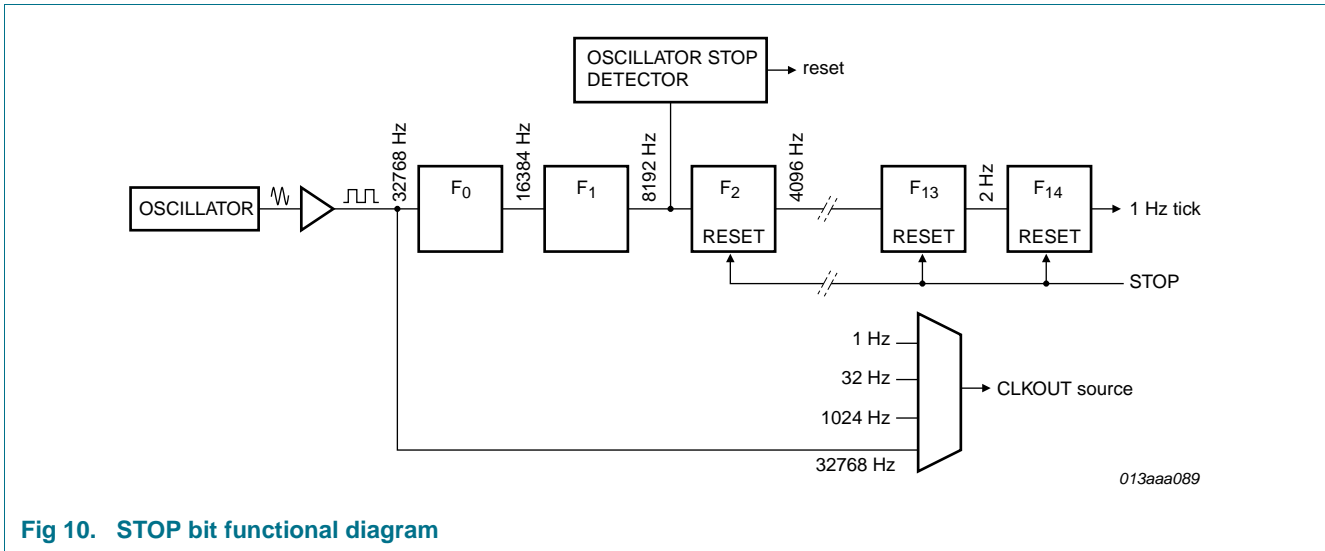

Fig 10. STOP bit functional diagram

The STOP bit function will not affect the output of 32.768 kHz on CLKOUT, but will stop the generation of 1.024 kHz, 32 Hz, and 1 Hz.

The lower two stages of the prescaler (F₀ and F₁) are not reset; and because the I²C-bus is asynchronous to the crystal oscillator, the accuracy of re-starting the time circuits will be between zero and one 8.192 kHz cycle (see Figure 11).

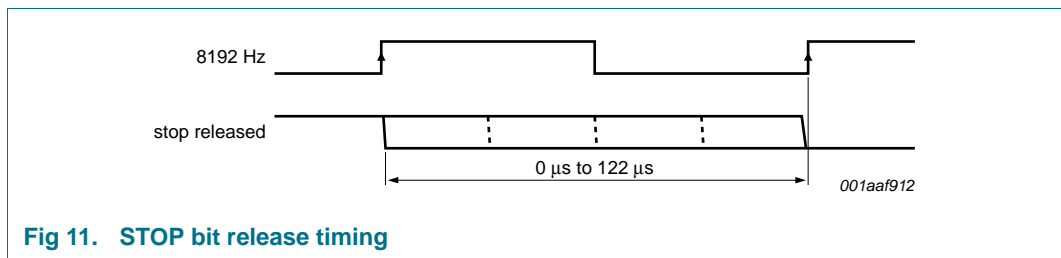

Fig 11. STOP bit release timing

Table 26. First increment of time circuits after STOP bit release

Bit	Prescaler bits	[1]	1 Hz tick	Time	Comment
STOP	F ₀ F ₁ -F ₂ to F ₁₄			hh:mm:ss	
Clock is running normally					
0	01-0 0001 1101 0100			12:45:12	prescaler counting normally
STOP bit is activated by user. F₀F₁ are not reset and values cannot be predicted externally					
1	XX-0 0000 0000 0000			12:45:12	prescaler is reset; time circuits are frozen
New time is set by user					
1	XX-0 0000 0000 0000			08:00:00	prescaler is reset; time circuits are frozen
STOP bit is released by user					
0	XX-0 0000 0000 0000			08:00:00	prescaler is now running
	XX-1 0000 0000 0000			08:00:00	-
	XX-0 1000 0000 0000			08:00:00	-
	XX-1 1000 0000 0000			08:00:00	-
	:			:	:
	11-1 1111 1111 1110			08:00:00	-
	00-0 0000 0000 0001			08:00:01	0 to 1 transition of F ₁₄ increments the time circuits
	10-0 0000 0000 0001			08:00:01	-
	:			:	:
	11-1 1111 1111 1111			08:00:01	-
	00-0 0000 0000 0000			08:00:01	-
	10-0 0000 0000 0000			08:00:01	-
	:			:	:
	11-1 1111 1111 1110			08:00:01	-
	00-0 0000 0000 0001			08:00:02	0 to 1 transition of F ₁₄ increments the time circuits

[1] F₀ is clocked at 32.768 kHz.

The first increment of the time circuits is between 0.507813 s and 0.507935 s after STOP bit is released. The uncertainty is caused by the prescaler bits F₀ and F₁ not being reset (see Table 26) and the unknown state of the 32 kHz clock.

8.11 Reset

The PCF8563 includes an internal reset circuit which is active whenever the oscillator is stopped. In the reset state the I²C-bus logic is initialized including the address pointer and all registers are set according to Table 27. I²C-bus communication is not possible during reset.

Table 27. Register reset value^[1]

Address	Register name	Bit							
		7	6	5	4	3	2	1	0
00h	Control_status_1	0	0	0	0	1	0	0	0
01h	Control_status_2	0	0	0	0	0	0	0	0
02h	VL_seconds	1	x	x	x	x	x	x	x
03h	Minutes	x	x	x	x	x	x	x	x
04h	Hours	x	x	x	x	x	x	x	x
05h	Days	x	x	x	x	x	x	x	x
06h	Weekdays	x	x	x	x	x	x	x	x
07h	Century_months	x	x	x	x	x	x	x	x
08h	Years	x	x	x	x	x	x	x	x
09h	Minute_alarm	1	x	x	x	x	x	x	x
0Ah	Hour_alarm	1	x	x	x	x	x	x	x
0Bh	Day_alarm	1	x	x	x	x	x	x	x
0Ch	Weekday_alarm	1	x	x	x	x	x	x	x
0Dh	CLKOUT_control	1	x	x	x	x	x	0	0
0Eh	Timer_control	0	x	x	x	x	x	1	1
0Fh	Timer	x	x	x	x	x	x	x	x

[1] Registers marked x are undefined at power-up and unchanged by subsequent resets.

8.11.1 Power-On Reset (POR) override

The POR duration is directly related to the crystal oscillator start-up time. Due to the long start-up times experienced by these types of circuits, a mechanism has been built in to disable the POR and hence speed up on-board test of the device. The setting of this mode requires that the I²C-bus pins, SDA and SCL, are toggled in a specific order as shown in Figure 12. All timings are required minimums.

Once the override mode has been entered, the device immediately stops, being reset, and normal operation may commence i.e. entry into the EXT_CLK test mode via I²C-bus access. The override mode may be cleared by writing logic 0 to TESTC. TESTC must be set to logic 1 before re-entry into the override mode is possible. Setting TESTC to logic 0 during normal operation has no effect except to prevent entry into the POR override mode.

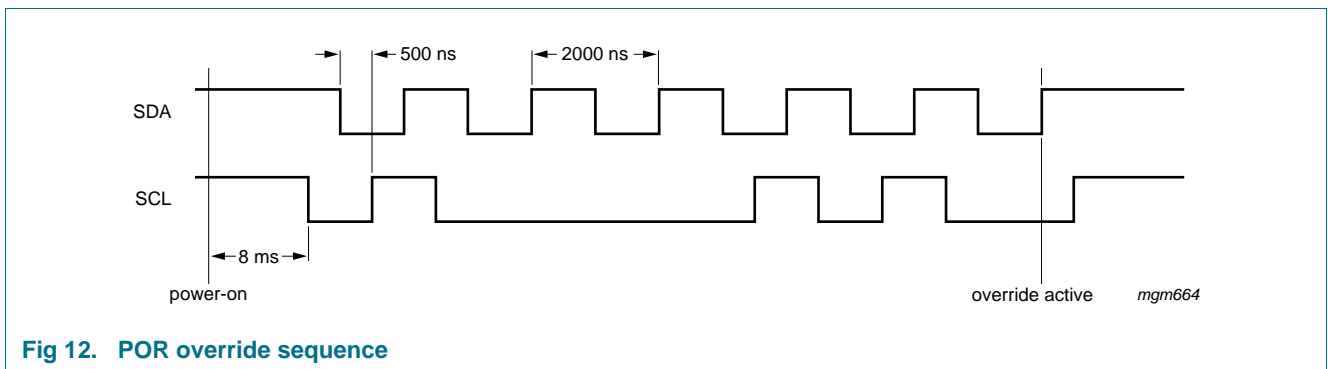

Fig 12. POR override sequence

9. Characteristics of the I²C-bus

The I²C-bus is for bidirectional, two-line communication between different ICs or modules. The two lines are a Serial DAta line (SDA) and a Serial CLock line (SCL). Both lines must be connected to a positive supply via a pull-up resistor. Data transfer may be initiated only when the bus is not busy.

9.1 Bit transfer

One data bit is transferred during each clock pulse. The data on the SDA line must remain stable during the HIGH period of the clock pulse as changes in the data line at this time will be interpreted as a control signal (see [Figure 13](#)).

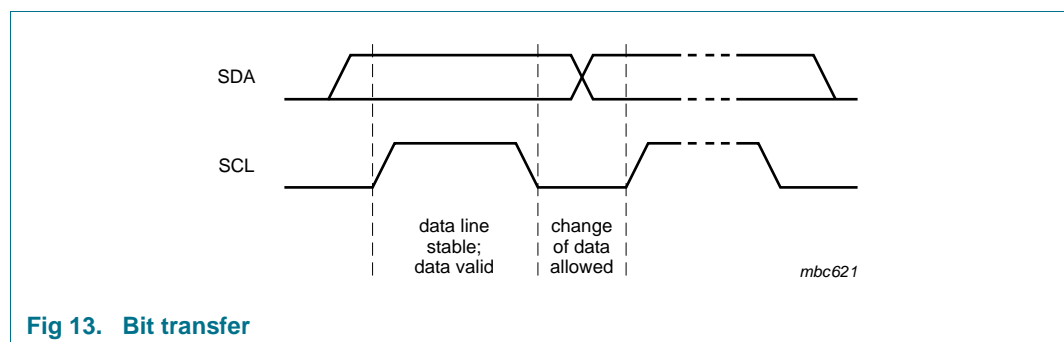

Fig 13. Bit transfer

9.2 START and STOP conditions

Both data and clock lines remain HIGH when the bus is not busy.

A HIGH-to-LOW transition of the data line while the clock is HIGH is defined as the START condition - S.

A LOW-to-HIGH transition of the data line while the clock is HIGH is defined as the STOP condition - P (see [Figure 14](#)).

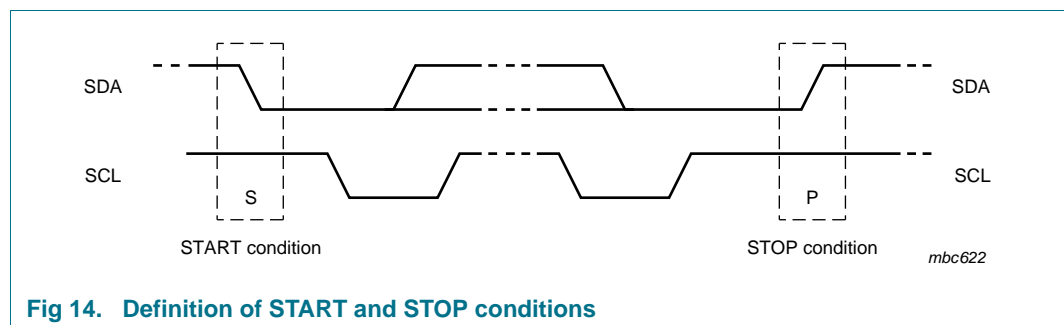

Fig 14. Definition of START and STOP conditions

9.3 System configuration

A device generating a message is a transmitter; a device receiving a message is a receiver. The device that controls the message is the master; and the devices which are controlled by the master are the slaves (see [Figure 15](#)).

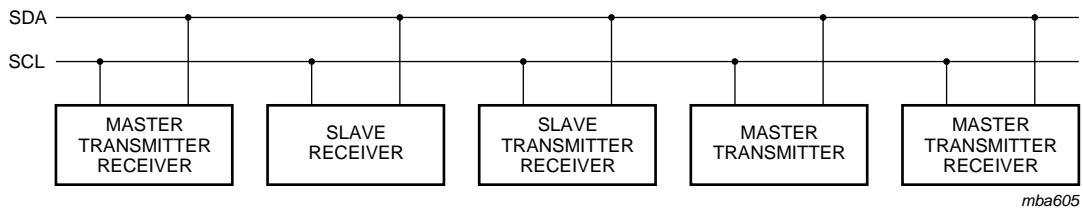

Fig 15. System configuration

9.4 Acknowledge

The number of data bytes transferred between the START and STOP conditions from transmitter to receiver is unlimited. Each byte of eight bits is followed by an acknowledge cycle.

- A slave receiver, which is addressed, must generate an acknowledge after the reception of each byte.
- Also a master receiver must generate an acknowledge after the reception of each byte that has been clocked out of the slave transmitter.
- The device that acknowledges must pull-down the SDA line during the acknowledge clock pulse, so that the SDA line is stable LOW during the HIGH period of the acknowledge related clock pulse (set-up and hold times must be taken into consideration).
- A master receiver must signal an end of data to the transmitter by not generating an acknowledge on the last byte that has been clocked out of the slave. In this event, the transmitter must leave the data line HIGH to enable the master to generate a STOP condition.

Acknowledgement on the I²C-bus is illustrated in [Figure 16](#).

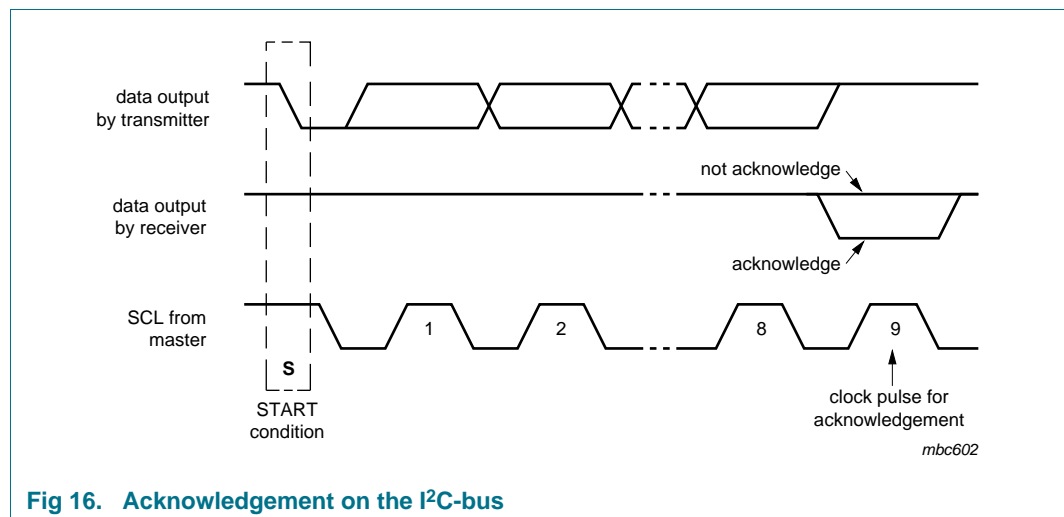

Fig 16. Acknowledgement on the I²C-bus

9.5 I²C-bus protocol

9.5.1 Addressing

Before any data is transmitted on the I²C-bus, the device which should respond is addressed first. The addressing is always carried out with the first byte transmitted after the start procedure.

The PCF8563 acts as a slave receiver or slave transmitter. Therefore the clock signal SCL is only an input signal, but the data signal SDA is a bidirectional line.

Two slave addresses are reserved for the PCF8563:

Read: A3h (10100011)

Write: A2h (10100010)

The PCF8563 slave address is illustrated in [Figure 17](#).

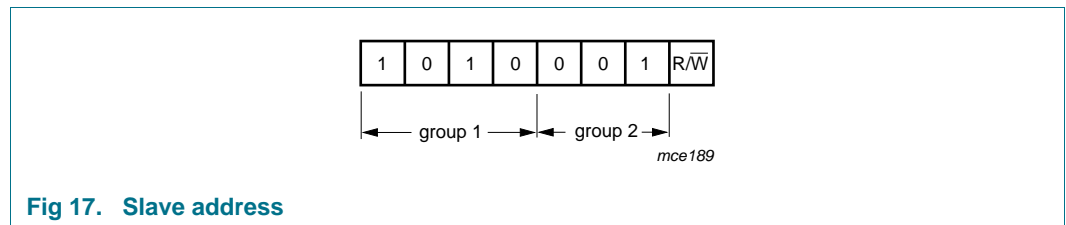

Fig 17. Slave address

9.5.2 Clock and calendar READ or WRITE cycles

The I²C-bus configuration for the different PCF8563 READ and WRITE cycles is shown in [Figure 18](#), [Figure 19](#) and [Figure 20](#). The register address is a 4-bit value that defines which register is to be accessed next. The upper four bits of the register address are not used.

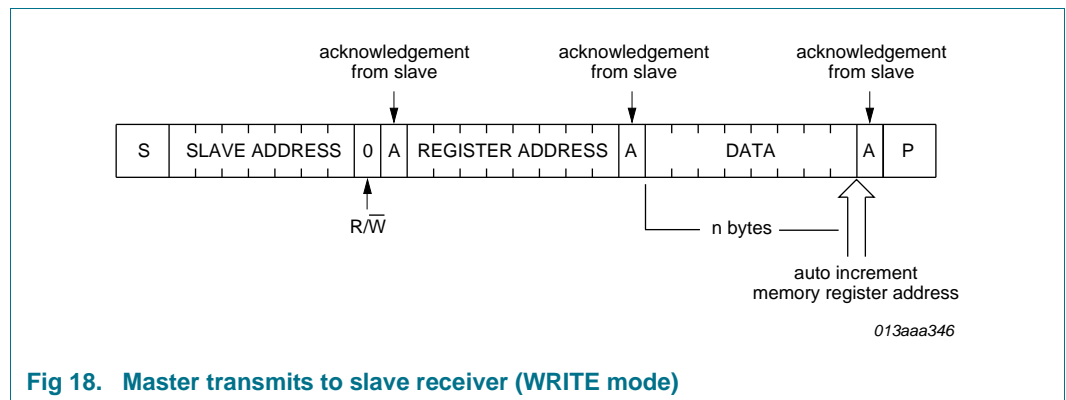
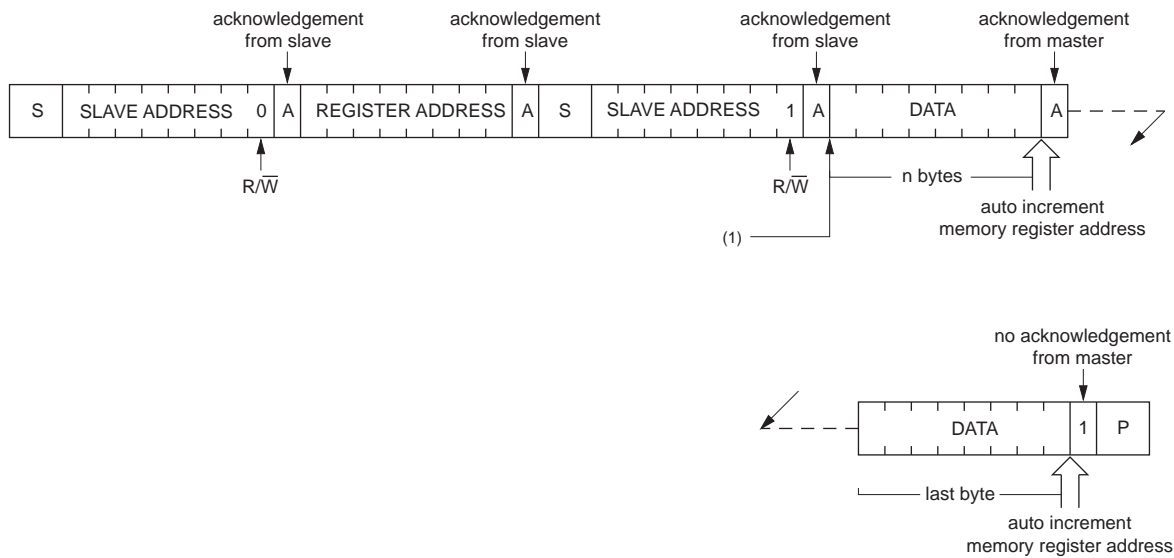

Fig 18. Master transmits to slave receiver (WRITE mode)



(1) At this moment master transmitter becomes master receiver and PCF8563 slave receiver becomes slave transmitter.

Fig 19. Master reads after setting register address (write register address; READ data)

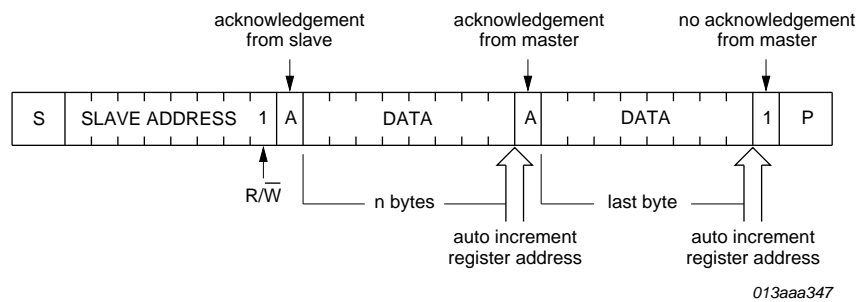

Fig 20. Master reads slave immediately after first byte (READ mode)

9.6 Interface watchdog timer

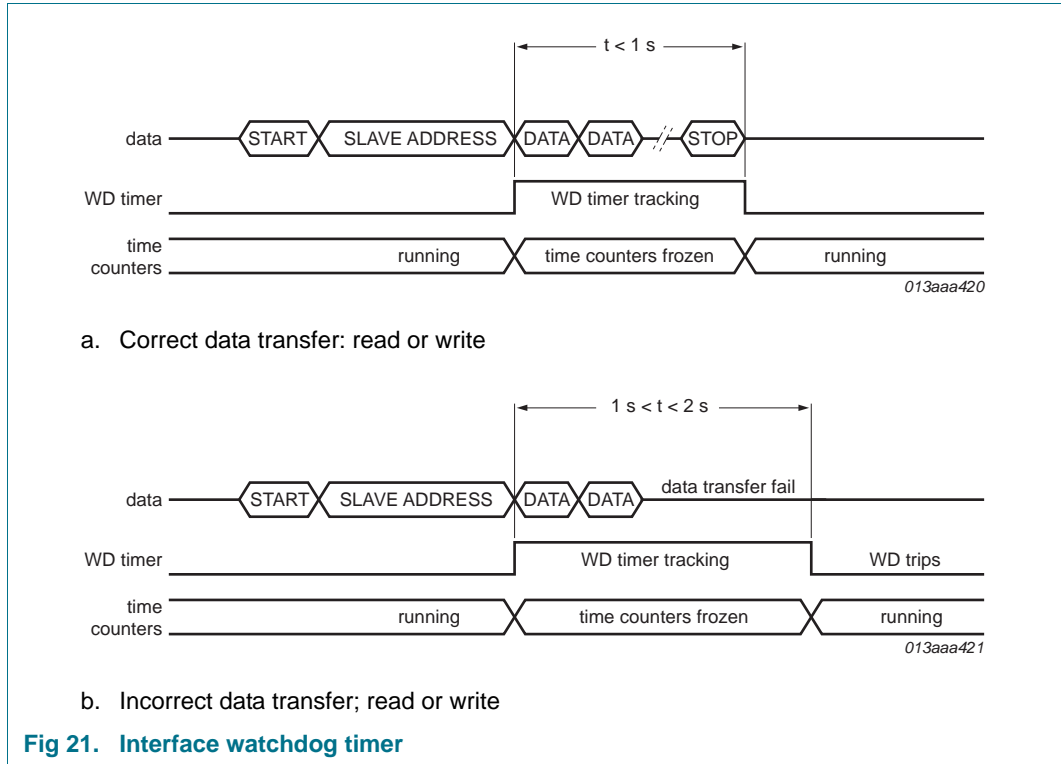

Fig 21. Interface watchdog timer

During read/write operations, the time counting circuits are frozen. To prevent a situation where the accessing device becomes locked and does not clear the interface, the PCF8563 has a built in watchdog timer. Should the interface be active for more than 1 s from the time a valid slave address is transmitted, then the PCF8563 will automatically clear the interface and allow the time counting circuits to continue counting. The watchdog will trigger between 1 s and 2 s after receiving a valid slave address. Each time the watchdog period is exceeded, 1 s will be lost from the time counters.

The watchdog is implemented to prevent the excessive loss of time due to interface access failure e.g. if main power is removed from a battery backed-up system during an interface access.

10. Internal circuitry

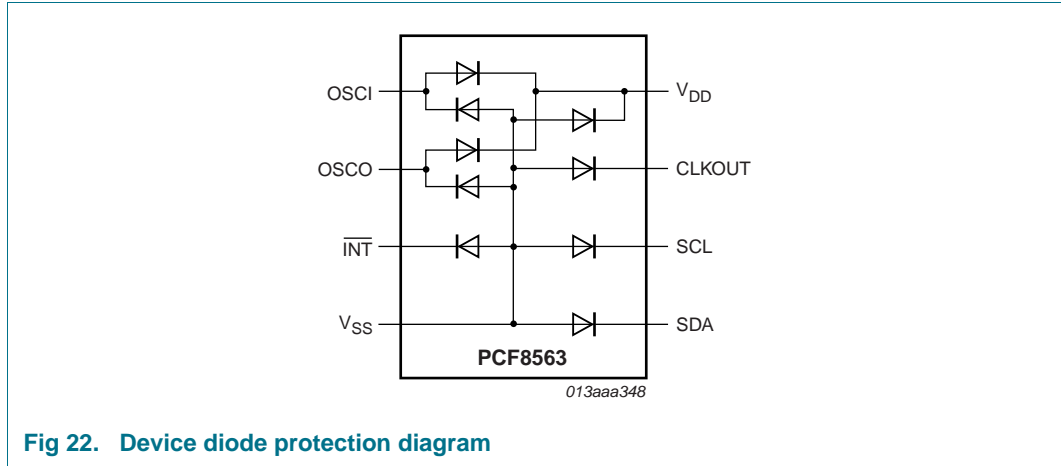

Fig 22. Device diode protection diagram

11. Limiting values

Table 28. Limiting values
In accordance with the Absolute Maximum Rating System (IEC 60134).

Symbol	Parameter	Conditions	Min	Max	Unit	
V _{DD}	supply voltage		-0.5	+6.5	V	
I _{DD}	supply current		-50	+50	mA	
V _I	input voltage	on pins SCL, SDA, and OSCI	-0.5	+6.5	V	
V _O	output voltage	on pins CLKOUT and $\overline{\text{INT}}$	-0.5	+6.5	V	
I _I	input current	at any input	-10	+10	mA	
I _O	output current	at any output	-10	+10	mA	
P _{tot}	total power dissipation		-	300	mW	
V _{ESD}	electrostatic discharge voltage	HBM				
		HVSON10 (PCF8563BS/4) [1]	-	±3500	V	
		SO8 (PCF8563T/F4) [1]				
		TSSOP8 (PCF8563TS/4) [1]				
		SO8 (PCF8563T/5) [1]	-	±2000	V	
		TSSOP8 (PCF8563TS/5) [1]	-			
		CDM				
		HVSON10 (PCF8563BS/4) [2]	-	±2000	V	
		SO8 (PCF8563T/F4) [2]	-	±1000	V	
		SO8 (PCF8563T/5) [2]	-	±1500	V	
		TSSOP8 (PCF8563TS/4) [2]	-	±1500	V	
		TSSOP8 (PCF8563TS/5) [2]	-	±1750	V	
I _{lu}	latch-up current		[3]	200	mA	
T _{stg}	storage temperature		[4]	-65	+150	°C
T _{amb}	ambient temperature	operating device	-40	+85	°C	

[1] Pass level; Human Body Model (HBM), according to [Ref. 5 "JESD22-A114"](#).

[2] Pass level; Charged-Device Model (CDM), according to [Ref. 6 "JESD22-C101"](#).

[3] Pass level; latch-up testing according to [Ref. 7 "JESD78"](#) at maximum ambient temperature (T_{amb(max)}).

[4] According to the NXP store and transport requirements (see [Ref. 9 "UM10569"](#)) the devices should be stored at a temperature of +8 °C to +45 °C and a humidity of 25 % to 75 %. For long term storage products deviant conditions are described in that document.

12. Static characteristics

Table 29. Static characteristics

$V_{DD} = 1.8\text{ V to }5.5\text{ V}$; $V_{SS} = 0\text{ V}$; $T_{amb} = -40\text{ °C to }+85\text{ °C}$; $f_{osc} = 32.768\text{ kHz}$; quartz $R_s = 40\text{ k}\Omega$; $C_L = 8\text{ pF}$; unless otherwise specified.

Symbol	Parameter	Conditions	Min	Typ	Max	Unit
Supplies						
V_{DD}	supply voltage	interface inactive; [1] $f_{SCL} = 0\text{ Hz}$; $T_{amb} = 25\text{ °C}$	1.0	-	5.5	V
		interface active; $f_{SCL} = 400\text{ kHz}$	1.8	-	5.5	V
		clock data integrity; $T_{amb} = 25\text{ °C}$	V_{low}	-	5.5	V
I_{DD}	supply current	interface active				
		$f_{SCL} = 400\text{ kHz}$	-	-	800	μA
		$f_{SCL} = 100\text{ kHz}$	-	-	200	μA
		interface inactive ($f_{SCL} = 0\text{ Hz}$); CLKOUT disabled; $T_{amb} = 25\text{ °C}$ [2]				
		$V_{DD} = 5.0\text{ V}$	-	275	550	nA
		$V_{DD} = 3.0\text{ V}$	-	250	500	nA
		$V_{DD} = 2.0\text{ V}$	-	225	450	nA
		interface inactive ($f_{SCL} = 0\text{ Hz}$); CLKOUT disabled; $T_{amb} = -40\text{ °C to }+85\text{ °C}$ [2]				
		$V_{DD} = 5.0\text{ V}$	-	500	750	nA
		$V_{DD} = 3.0\text{ V}$	-	400	650	nA
		$V_{DD} = 2.0\text{ V}$	-	400	600	nA
		interface inactive ($f_{SCL} = 0\text{ Hz}$); CLKOUT enabled at 32 kHz; $T_{amb} = 25\text{ °C}$ [2]				
		$V_{DD} = 5.0\text{ V}$	-	825	1600	nA
		$V_{DD} = 3.0\text{ V}$	-	550	1000	nA
		$V_{DD} = 2.0\text{ V}$	-	425	800	nA
interface inactive ($f_{SCL} = 0\text{ Hz}$); CLKOUT enabled at 32 kHz; $T_{amb} = -40\text{ °C to }+85\text{ °C}$ [2]						
$V_{DD} = 5.0\text{ V}$	-	950	1700	nA		
$V_{DD} = 3.0\text{ V}$	-	650	1100	nA		
$V_{DD} = 2.0\text{ V}$	-	500	900	nA		
Inputs						
V_{IL}	LOW-level input voltage		-0.5	-	$+0.3V_{DD}$	V
V_{IH}	HIGH-level input voltage		$0.7V_{DD}$	-	5.5	V
I_{LI}	input leakage current	$V_I = V_{DD}$ or V_{SS}	-1	0	+1	μA
C_i	input capacitance	[3]	-	-	7	pF

Table 29. Static characteristics ...continued

$V_{DD} = 1.8\text{ V to }5.5\text{ V}$; $V_{SS} = 0\text{ V}$; $T_{amb} = -40\text{ }^{\circ}\text{C to }+85\text{ }^{\circ}\text{C}$; $f_{osc} = 32.768\text{ kHz}$; quartz $R_s = 40\text{ k}\Omega$; $C_L = 8\text{ pF}$; unless otherwise specified.

Symbol	Parameter	Conditions	Min	Typ	Max	Unit
Outputs						
I_{OL}	LOW-level output current	output sink current; $V_{OL} = 0.4\text{ V}$; $V_{DD} = 5\text{ V}$				
		on pin SDA	3	-	-	mA
		on pin $\overline{\text{INT}}$	1	-	-	mA
		on pin CLKOUT	1	-	-	mA
I_{LO}	output leakage current	$V_O = V_{DD}\text{ or }V_{SS}$	-1	0	+1	μA
Voltage detector						
V_{low}	low voltage	$T_{amb} = 25\text{ }^{\circ}\text{C}$; sets bit VL; see Figure 6	-	0.9	1.0	V

- [1] For reliable oscillator start-up at power on use V_{DD} greater than 1.3 V. If powered up at 1.0 V the oscillator will start but it might be a bit slow, especially if at high temperature. Normally the power supply is not 1.0 V at start up and only comes at the end of battery discharge. V_{DD} min of 1.0 V is specified so that the customer can calculate how large a battery or capacitor they need for their application. V_{DD} min of 1.3 V or greater is needed to ensure speedy oscillator start-up time.
- [2] Timer source clock = $1/60$ Hz, level of pins SCL and SDA is V_{DD} or V_{SS} .
- [3] Tested on sample basis.

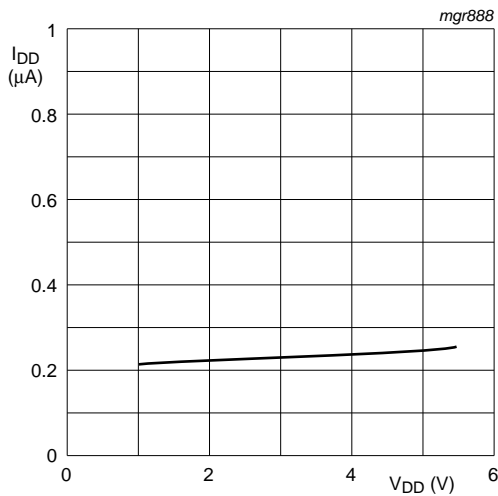

$T_{amb} = 25\text{ }^{\circ}\text{C}$; Timer = 1 minute.

Fig 23. Supply current I_{DD} as a function of supply voltage V_{DD} ; CLKOUT disabled

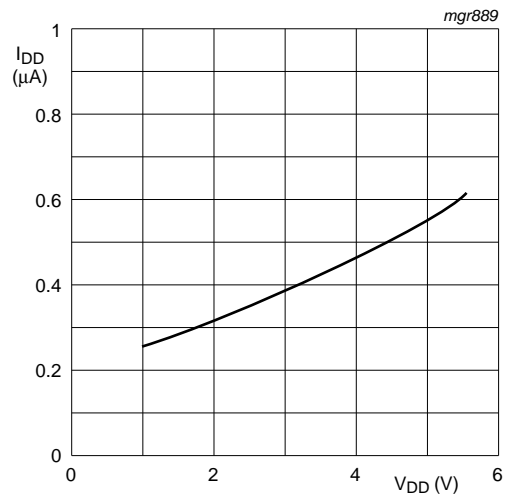

$T_{amb} = 25\text{ }^{\circ}\text{C}$; Timer = 1 minute.

Fig 24. Supply current I_{DD} as a function of supply voltage V_{DD} ; CLKOUT = 32 kHz

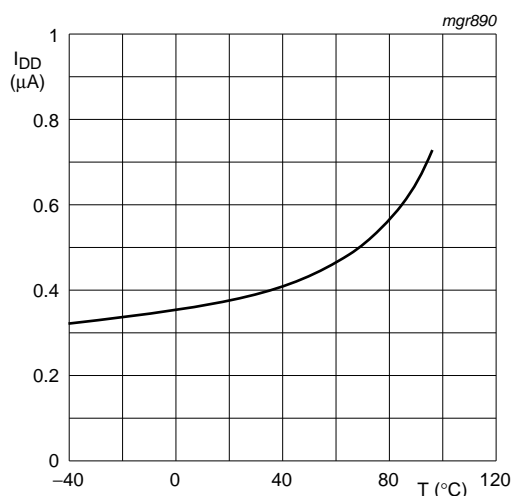

V_{DD} = 3 V; Timer = 1 minute.

Fig 25. Supply current I_{DD} as a function of temperature T; CLKOUT = 32 kHz

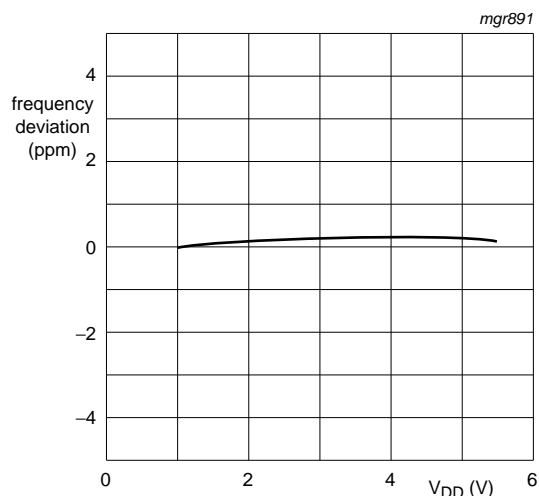

T_{amb} = 25 °C; normalized to V_{DD} = 3 V.

Fig 26. Frequency deviation as a function of supply voltage V_{DD}

13. Dynamic characteristics

Table 30. Dynamic characteristics

V_{DD} = 1.8 V to 5.5 V; V_{SS} = 0 V; T_{amb} = -40 °C to +85 °C; f_{osc} = 32.768 kHz; quartz R_s = 40 kΩ; C_L = 8 pF; unless otherwise specified.

Symbol	Parameter	Conditions	Min	Typ	Max	Unit
Oscillator						
C _{OSCO}	capacitance on pin OSCO		15	25	35	pF
Δf _{osc} /f _{osc}	relative oscillator frequency variation	ΔV _{DD} = 200 mV; T _{amb} = 25 °C	-	0.2	-	ppm
Quartz crystal parameters (f = 32.768 kHz)						
R _s	series resistance		-	-	100	kΩ
C _L	load capacitance	parallel	[1] 7	-	12.5	pF
C _{trim}	trimmer capacitance	external; on pin OSCI	5	-	25	pF
CLKOUT output						
δ _{CLKOUT}	duty cycle on pin CLKOUT		[2] -	50	-	%
I²C-bus timing characteristics (see Figure 27)[3][4]						
f _{SCL}	SCL clock frequency		[5] -	-	400	kHz
t _{HD;STA}	hold time (repeated) START condition		0.6	-	-	µs
t _{SU;STA}	set-up time for a repeated START condition		0.6	-	-	µs
t _{LOW}	LOW period of the SCL clock		1.3	-	-	µs
t _{HIGH}	HIGH period of the SCL clock		0.6	-	-	µs
t _r	rise time of both SDA and SCL signals					
		standard-mode	-	-	1	µs
		fast-mode	-	-	0.3	µs

Table 30. Dynamic characteristics ...continued

$V_{DD} = 1.8\text{ V to }5.5\text{ V}$; $V_{SS} = 0\text{ V}$; $T_{amb} = -40\text{ }^{\circ}\text{C to }+85\text{ }^{\circ}\text{C}$; $f_{osc} = 32.768\text{ kHz}$; quartz $R_s = 40\text{ k}\Omega$; $C_L = 8\text{ pF}$; unless otherwise specified.

Symbol	Parameter	Conditions	Min	Typ	Max	Unit
t_f	fall time of both SDA and SCL signals		-	-	0.3	μs
t_{BUF}	bus free time between a STOP and START condition		1.3	-	-	μs
C_b	capacitive load for each bus line		-	-	400	pF
$t_{SU;DAT}$	data set-up time		100	-	-	ns
$t_{HD;DAT}$	data hold time		0	-	-	ns
$t_{SU;STO}$	set-up time for STOP condition		0.6	-	-	μs
$t_w(\text{spike})$	spike pulse width	on bus	-	-	50	ns

[1] C_L is a calculation of C_{trim} and C_{OSCO} in series: $C_L = \frac{(C_{trim} \cdot C_{OSCO})}{(C_{trim} + C_{OSCO})}$.

[2] Unspecified for $f_{CLKOUT} = 32.768\text{ kHz}$.

[3] All timing values are valid within the operating supply voltage at ambient temperature and referenced to V_{IL} and V_{IH} with an input voltage swing of V_{SS} to V_{DD} .

[4] A detailed description of the I²C-bus specification is given in [Ref. 11 "UM10204"](#).

[5] I²C-bus access time between two STARTs or between a START and a STOP condition to this device must be less than one second.

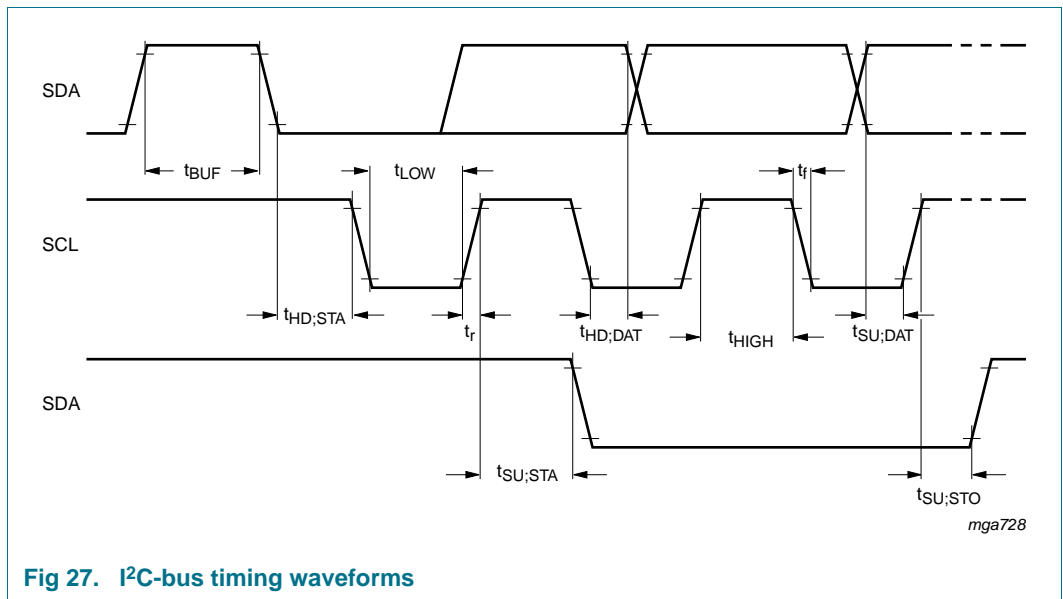

14. Application information

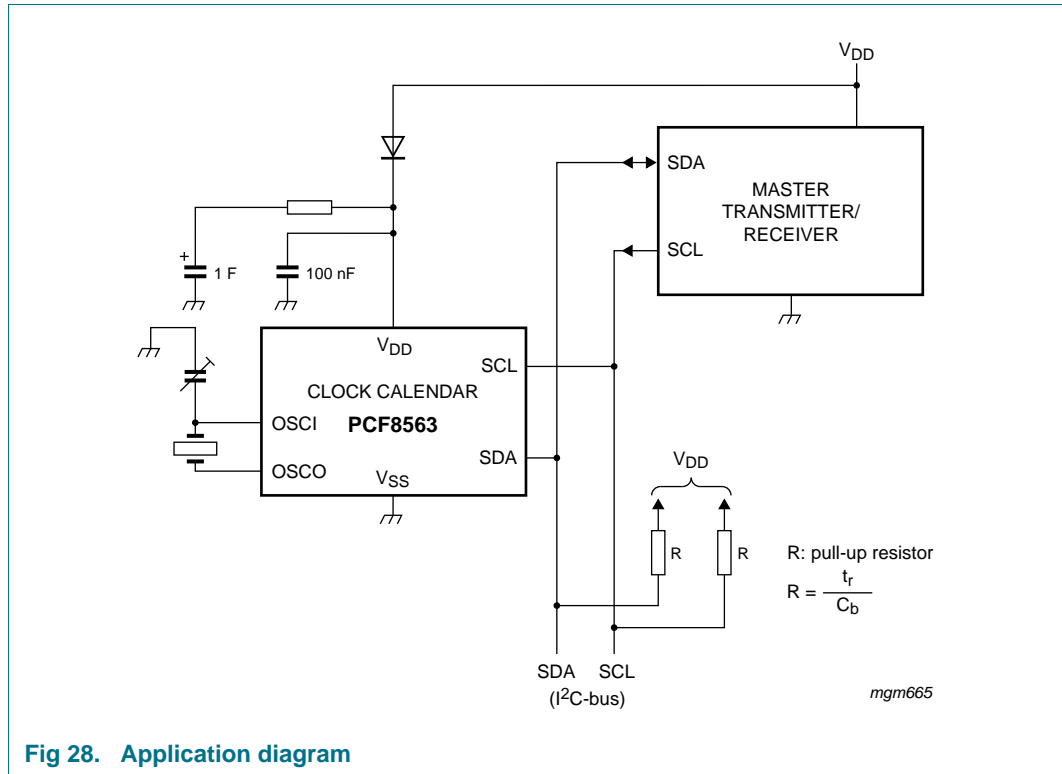

Fig 28. Application diagram

14.1 Quartz frequency adjustment

14.1.1 Method 1: fixed OSCI capacitor

By evaluating the average capacitance necessary for the application layout, a fixed capacitor can be used. The frequency is best measured via the 32.768 kHz signal available after power-on at pin CLKOUT. The frequency tolerance depends on the quartz crystal tolerance, the capacitor tolerance and the device-to-device tolerance (on average ± 5 ppm). Average deviations of ± 5 minutes per year can be easily achieved.

14.1.2 Method 2: OSCI trimmer

Using the 32.768 kHz signal available after power-on at pin CLKOUT, fast setting of a trimmer is possible.

14.1.3 Method 3: OSCO output

Direct measurement of OSCO out (accounting for test probe capacitance).

15. Package outline

HVSON10: plastic thermal enhanced very thin small outline package; no leads;
10 terminals; body 3 x 3 x 0.85 mm

SOT650-1

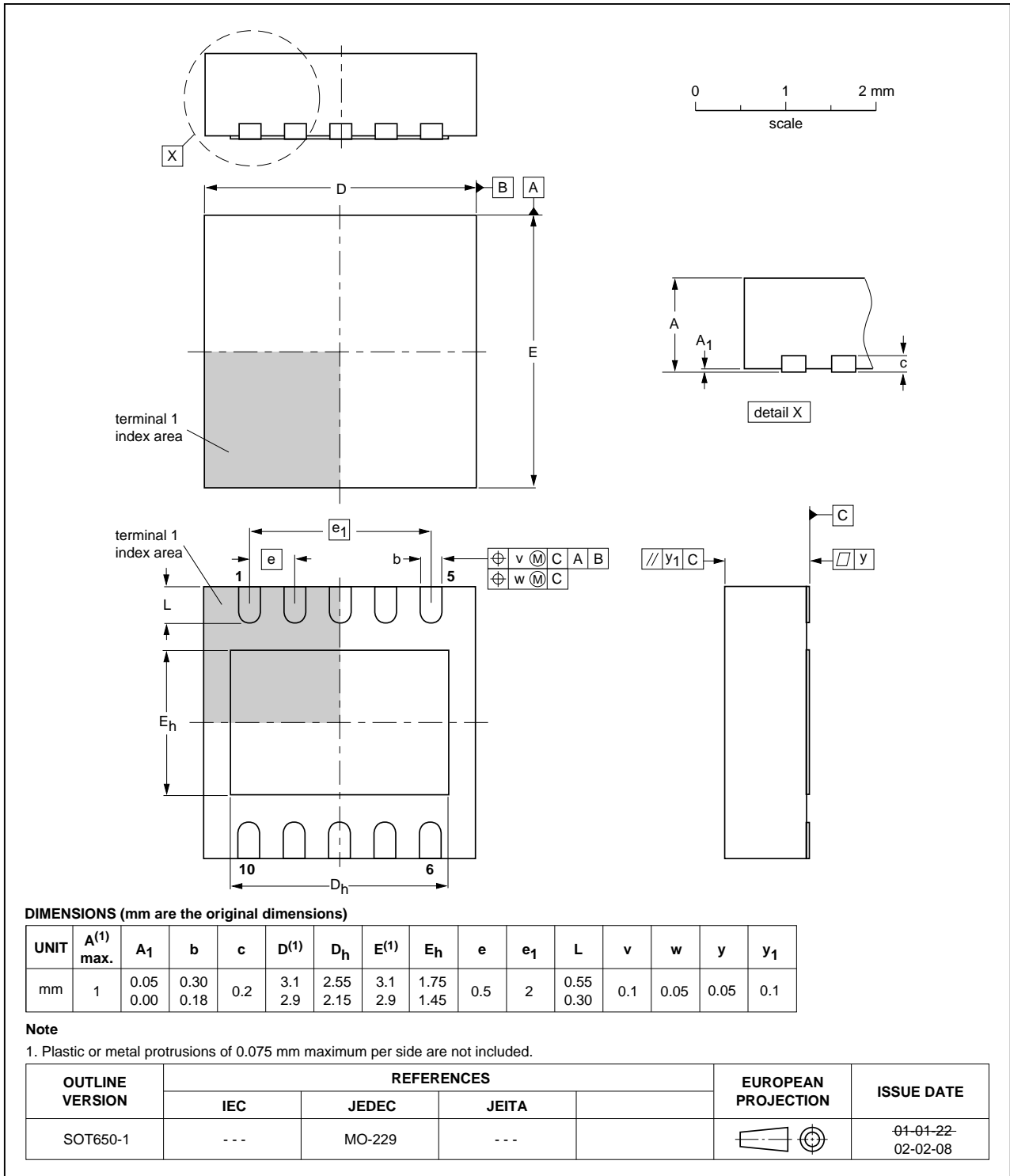

Fig 29. Package outline SOT650-1 (HVSON10) of PCF8563BS

SO8: plastic small outline package; 8 leads; body width 3.9 mm

SOT96-1

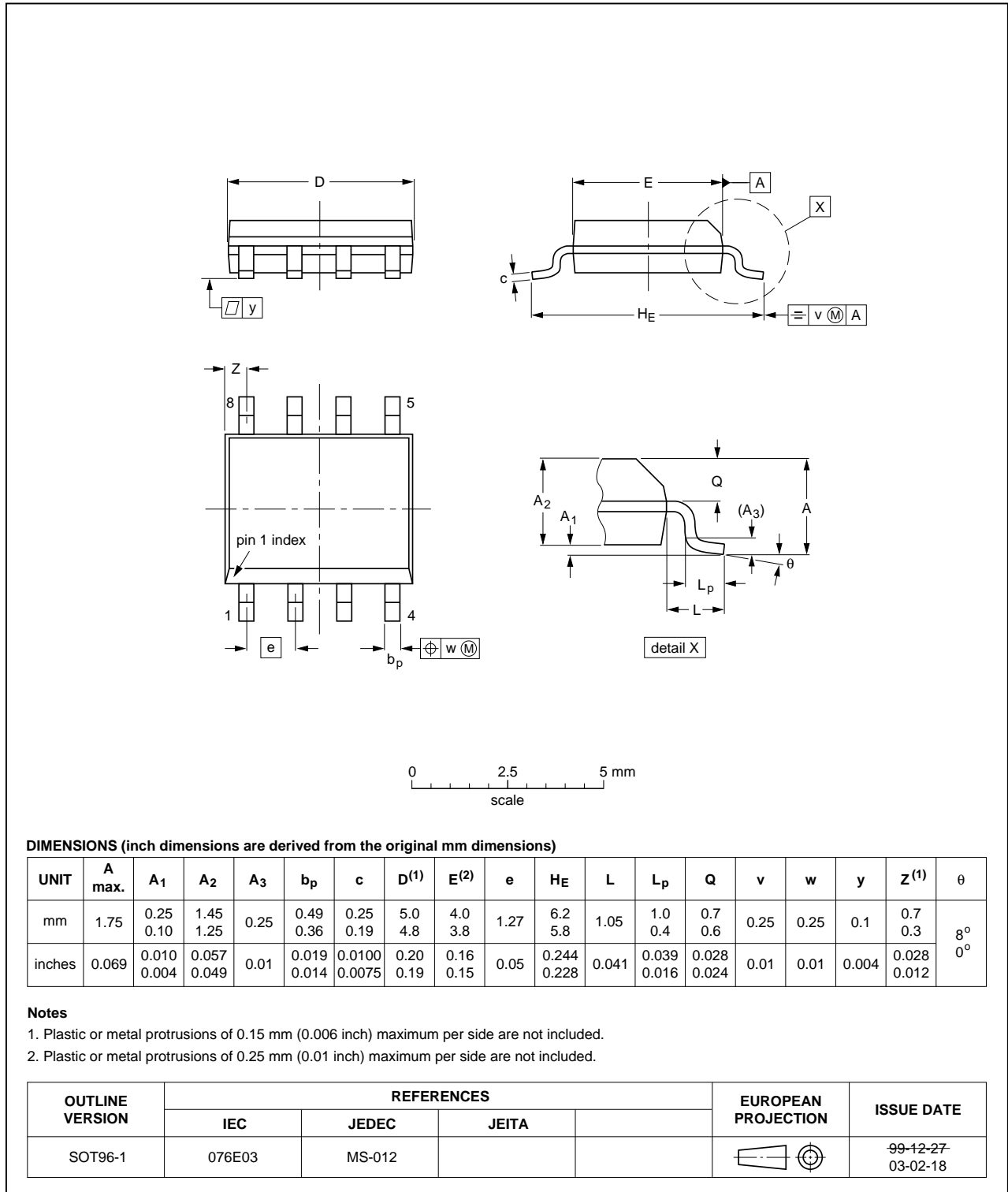

Fig 30. Package outline SOT96-1 (SO8) of PCF8563T

TSSOP8: plastic thin shrink small outline package; 8 leads; body width 3 mm

SOT505-1

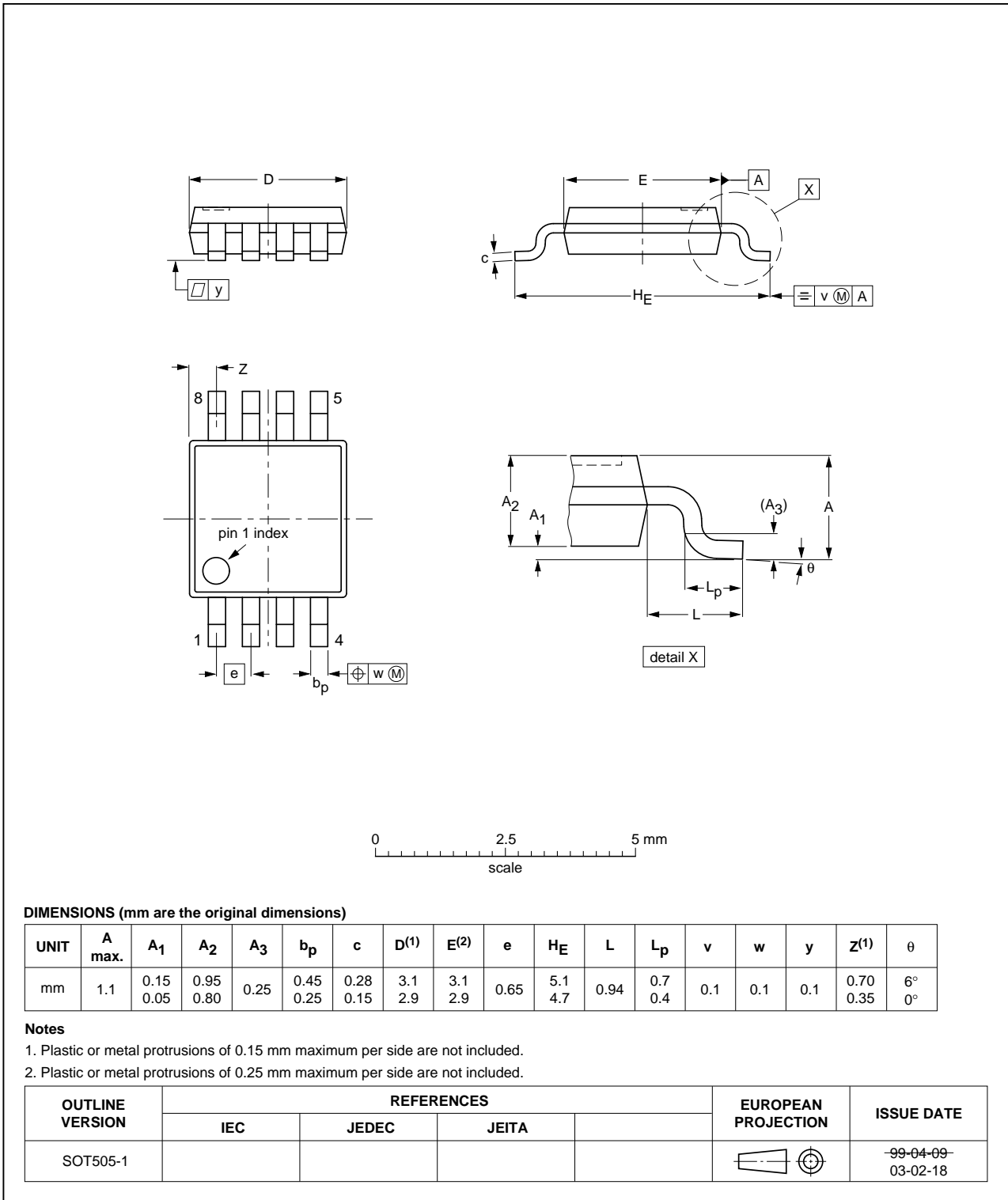

Fig 31. Package outline SOT505-1 (TSSOP8) of PCF8563TS

16. Handling information

All input and output pins are protected against ElectroStatic Discharge (ESD) under normal handling. When handling Metal-Oxide Semiconductor (MOS) devices ensure that all normal precautions are taken as described in *JESD625-A*, *IEC 61340-5* or equivalent standards.

17. Soldering of SMD packages

This text provides a very brief insight into a complex technology. A more in-depth account of soldering ICs can be found in Application Note *AN10365 "Surface mount reflow soldering description"*.

17.1 Introduction to soldering

Soldering is one of the most common methods through which packages are attached to Printed Circuit Boards (PCBs), to form electrical circuits. The soldered joint provides both the mechanical and the electrical connection. There is no single soldering method that is ideal for all IC packages. Wave soldering is often preferred when through-hole and Surface Mount Devices (SMDs) are mixed on one printed wiring board; however, it is not suitable for fine pitch SMDs. Reflow soldering is ideal for the small pitches and high densities that come with increased miniaturization.

17.2 Wave and reflow soldering

Wave soldering is a joining technology in which the joints are made by solder coming from a standing wave of liquid solder. The wave soldering process is suitable for the following:

- Through-hole components
- Leaded or leadless SMDs, which are glued to the surface of the printed circuit board

Not all SMDs can be wave soldered. Packages with solder balls, and some leadless packages which have solder lands underneath the body, cannot be wave soldered. Also, leaded SMDs with leads having a pitch smaller than ~0.6 mm cannot be wave soldered, due to an increased probability of bridging.

The reflow soldering process involves applying solder paste to a board, followed by component placement and exposure to a temperature profile. Leaded packages, packages with solder balls, and leadless packages are all reflow solderable.

Key characteristics in both wave and reflow soldering are:

- Board specifications, including the board finish, solder masks and vias
- Package footprints, including solder thieves and orientation
- The moisture sensitivity level of the packages
- Package placement
- Inspection and repair
- Lead-free soldering versus SnPb soldering

17.3 Wave soldering

Key characteristics in wave soldering are:

- Process issues, such as application of adhesive and flux, clinching of leads, board transport, the solder wave parameters, and the time during which components are exposed to the wave
- Solder bath specifications, including temperature and impurities

17.4 Reflow soldering

Key characteristics in reflow soldering are:

- Lead-free versus SnPb soldering; note that a lead-free reflow process usually leads to higher minimum peak temperatures (see [Figure 32](#)) than a SnPb process, thus reducing the process window
- Solder paste printing issues including smearing, release, and adjusting the process window for a mix of large and small components on one board
- Reflow temperature profile; this profile includes preheat, reflow (in which the board is heated to the peak temperature) and cooling down. It is imperative that the peak temperature is high enough for the solder to make reliable solder joints (a solder paste characteristic). In addition, the peak temperature must be low enough that the packages and/or boards are not damaged. The peak temperature of the package depends on package thickness and volume and is classified in accordance with [Table 31](#) and [32](#)

Table 31. SnPb eutectic process (from J-STD-020D)

Package thickness (mm)	Package reflow temperature (°C)	
	Volume (mm ³)	
	< 350	≥ 350
< 2.5	235	220
≥ 2.5	220	220

Table 32. Lead-free process (from J-STD-020D)

Package thickness (mm)	Package reflow temperature (°C)		
	Volume (mm ³)		
	< 350	350 to 2000	> 2000
< 1.6	260	260	260
1.6 to 2.5	260	250	245
> 2.5	250	245	245

Moisture sensitivity precautions, as indicated on the packing, must be respected at all times.

Studies have shown that small packages reach higher temperatures during reflow soldering, see [Figure 32](#).

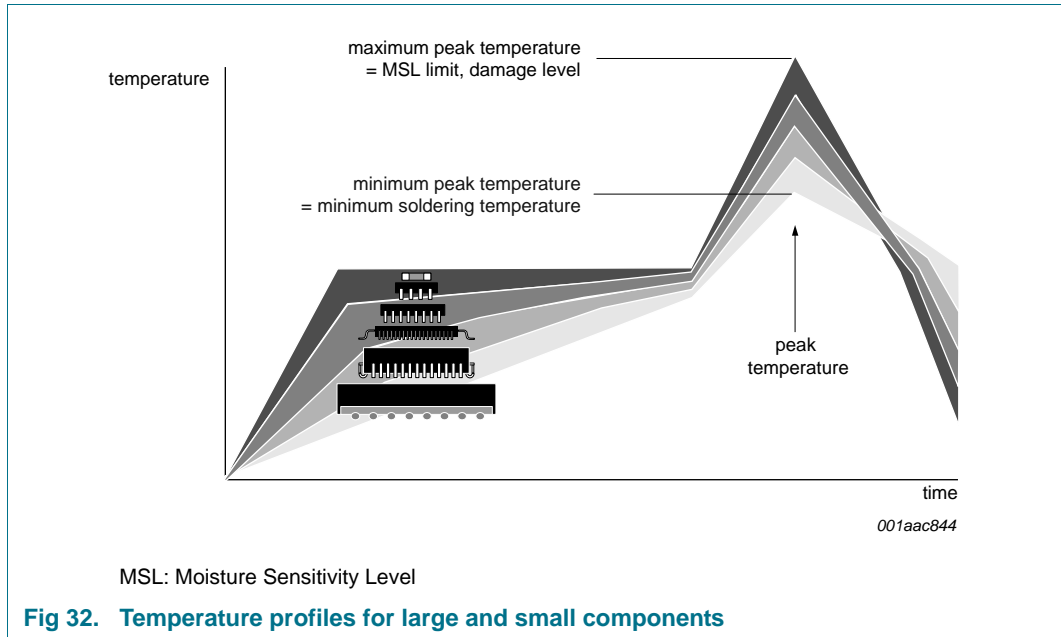

For further information on temperature profiles, refer to Application Note AN10365 “Surface mount reflow soldering description”.

18. Abbreviations

Table 33. Abbreviations

Acronym	Description
BCD	Binary Coded Decimal
CDM	Charged-Device Model
CMOS	Complementary Metal Oxide Semiconductor
ESD	ElectroStatic Discharge
HBM	Human Body Model
I ² C	Inter-Integrated Circuit
IC	Integrated Circuit
LSB	Least Significant Bit
MSB	Most Significant Bit
MSL	Moisture Sensitivity Level
PCB	Printed-Circuit Board
POR	Power-On Reset
RTC	Real-Time Clock
SCL	Serial CLock line
SDA	Serial DATA line
SMD	Surface Mount Device

19. References

- [1] **AN10365** — Surface mount reflow soldering description
- [2] **IEC 60134** — Rating systems for electronic tubes and valves and analogous semiconductor devices
- [3] **IEC 61340-5** — Protection of electronic devices from electrostatic phenomena
- [4] **IPC/JEDEC J-STD-020** — Moisture/Reflow Sensitivity Classification for Nonhermetic Solid State Surface Mount Devices
- [5] **JESD22-A114** — Electrostatic Discharge (ESD) Sensitivity Testing Human Body Model (HBM)
- [6] **JESD22-C101** — Field-Induced Charged-Device Model Test Method for Electrostatic-Discharge-Withstand Thresholds of Microelectronic Components
- [7] **JESD78** — IC Latch-Up Test
- [8] **JESD625-A** — Requirements for Handling Electrostatic-Discharge-Sensitive (ESDS) Devices
- [9] **UM10569** — NXP store and transport requirements
- [10] **SNV-FA-01-02** — Marking Formats Integrated Circuits
- [11] **UM10204** — I²C-bus specification and user manual

20. Revision history

Table 34. Revision history

Document ID	Release date	Data sheet status	Change notice	Supersedes
PCF8563 v.11	20151026	Product data sheet	-	PCF8563 v.10
Modifications:	<ul style="list-style-type: none"> Removed DIP8 package Table 3: Corrected Table note 1 Table 28, Table note 4: Corrected “the devices have to be stored” to “the devices should be stored” Table 29: <ul style="list-style-type: none"> Deleted Table note 1 from $V_{DD} f_{SCL} = 400$ kHz V_{IL}: Corrected V_{SS} to -0.5 V_{IH}: Corrected V_{DD} to 5.5 Corrected Table note 1 			
PCF8563 v.10	20120403	Product data sheet	-	PCF8563 v.9
Modifications:	<ul style="list-style-type: none"> Adjusted marking codes Adjusted text for FE = 0 in Table 22 			
PCF8563 v.9	20110616	Product data sheet	-	PCF8563 v.8
PCF8563 v.8	20101118	Product data sheet	-	PCF8563 v.7
PCF8563 v.7	20100723	Product data sheet	-	PCF8563_6
PCF8563_6	20080221	Product data sheet	-	PCF8563_5
PCF8563_5	20070717	Product data sheet	-	PCF8563-04
PCF8563-04 (9397 750 12999)	20040312	Product data	-	PCF8563-03
PCF8563-03 (9397 750 11158)	20030414	Product data	-	PCF8563-02
PCF8563-02 (9397 750 04855)	19990416	Product data	-	PCF8563_N_1
PCF8563_N_1 (9397 750 03282)	19980325	Objective specification	-	-

21. Legal information

21.1 Data sheet status

Document status ^{[1][2]}	Product status ^[3]	Definition
Objective [short] data sheet	Development	This document contains data from the objective specification for product development.
Preliminary [short] data sheet	Qualification	This document contains data from the preliminary specification.
Product [short] data sheet	Production	This document contains the product specification.

[1] Please consult the most recently issued document before initiating or completing a design.

[2] The term 'short data sheet' is explained in section "Definitions".

[3] The product status of device(s) described in this document may have changed since this document was published and may differ in case of multiple devices. The latest product status information is available on the Internet at URL <http://www.nxp.com>.

21.2 Definitions

Draft — The document is a draft version only. The content is still under internal review and subject to formal approval, which may result in modifications or additions. NXP Semiconductors does not give any representations or warranties as to the accuracy or completeness of information included herein and shall have no liability for the consequences of use of such information.

Short data sheet — A short data sheet is an extract from a full data sheet with the same product type number(s) and title. A short data sheet is intended for quick reference only and should not be relied upon to contain detailed and full information. For detailed and full information see the relevant full data sheet, which is available on request via the local NXP Semiconductors sales office. In case of any inconsistency or conflict with the short data sheet, the full data sheet shall prevail.

Product specification — The information and data provided in a Product data sheet shall define the specification of the product as agreed between NXP Semiconductors and its customer, unless NXP Semiconductors and customer have explicitly agreed otherwise in writing. In no event however, shall an agreement be valid in which the NXP Semiconductors product is deemed to offer functions and qualities beyond those described in the Product data sheet.

21.3 Disclaimers

Limited warranty and liability — Information in this document is believed to be accurate and reliable. However, NXP Semiconductors does not give any representations or warranties, expressed or implied, as to the accuracy or completeness of such information and shall have no liability for the consequences of use of such information. NXP Semiconductors takes no responsibility for the content in this document if provided by an information source outside of NXP Semiconductors.

In no event shall NXP Semiconductors be liable for any indirect, incidental, punitive, special or consequential damages (including - without limitation - lost profits, lost savings, business interruption, costs related to the removal or replacement of any products or rework charges) whether or not such damages are based on tort (including negligence), warranty, breach of contract or any other legal theory.

Notwithstanding any damages that customer might incur for any reason whatsoever, NXP Semiconductors' aggregate and cumulative liability towards customer for the products described herein shall be limited in accordance with the *Terms and conditions of commercial sale* of NXP Semiconductors.

Right to make changes — NXP Semiconductors reserves the right to make changes to information published in this document, including without limitation specifications and product descriptions, at any time and without notice. This document supersedes and replaces all information supplied prior to the publication hereof.

Suitability for use — NXP Semiconductors products are not designed, authorized or warranted to be suitable for use in life support, life-critical or safety-critical systems or equipment, nor in applications where failure or malfunction of an NXP Semiconductors product can reasonably be expected to result in personal injury, death or severe property or environmental damage. NXP Semiconductors and its suppliers accept no liability for inclusion and/or use of NXP Semiconductors products in such equipment or applications and therefore such inclusion and/or use is at the customer's own risk.

Applications — Applications that are described herein for any of these products are for illustrative purposes only. NXP Semiconductors makes no representation or warranty that such applications will be suitable for the specified use without further testing or modification.

Customers are responsible for the design and operation of their applications and products using NXP Semiconductors products, and NXP Semiconductors accepts no liability for any assistance with applications or customer product design. It is customer's sole responsibility to determine whether the NXP Semiconductors product is suitable and fit for the customer's applications and products planned, as well as for the planned application and use of customer's third party customer(s). Customers should provide appropriate design and operating safeguards to minimize the risks associated with their applications and products.

NXP Semiconductors does not accept any liability related to any default, damage, costs or problem which is based on any weakness or default in the customer's applications or products, or the application or use by customer's third party customer(s). Customer is responsible for doing all necessary testing for the customer's applications and products using NXP Semiconductors products in order to avoid a default of the applications and the products or of the application or use by customer's third party customer(s). NXP does not accept any liability in this respect.

Limiting values — Stress above one or more limiting values (as defined in the Absolute Maximum Ratings System of IEC 60134) will cause permanent damage to the device. Limiting values are stress ratings only and (proper) operation of the device at these or any other conditions above those given in the Recommended operating conditions section (if present) or the Characteristics sections of this document is not warranted. Constant or repeated exposure to limiting values will permanently and irreversibly affect the quality and reliability of the device.

Terms and conditions of commercial sale — NXP Semiconductors products are sold subject to the general terms and conditions of commercial sale, as published at <http://www.nxp.com/profile/terms>, unless otherwise agreed in a valid written individual agreement. In case an individual agreement is concluded only the terms and conditions of the respective agreement shall apply. NXP Semiconductors hereby expressly objects to applying the customer's general terms and conditions with regard to the purchase of NXP Semiconductors products by customer.

No offer to sell or license — Nothing in this document may be interpreted or construed as an offer to sell products that is open for acceptance or the grant, conveyance or implication of any license under any copyrights, patents or other industrial or intellectual property rights.

Export control — This document as well as the item(s) described herein may be subject to export control regulations. Export might require a prior authorization from competent authorities.

Non-automotive qualified products — Unless this data sheet expressly states that this specific NXP Semiconductors product is automotive qualified, the product is not suitable for automotive use. It is neither qualified nor tested in accordance with automotive testing or application requirements. NXP Semiconductors accepts no liability for inclusion and/or use of non-automotive qualified products in automotive equipment or applications.

In the event that customer uses the product for design-in and use in automotive applications to automotive specifications and standards, customer (a) shall use the product without NXP Semiconductors' warranty of the product for such automotive applications, use and specifications, and (b) whenever customer uses the product for automotive applications beyond NXP Semiconductors' specifications such use shall be solely at customer's

own risk, and (c) customer fully indemnifies NXP Semiconductors for any liability, damages or failed product claims resulting from customer design and use of the product for automotive applications beyond NXP Semiconductors' standard warranty and NXP Semiconductors' product specifications.

Translations — A non-English (translated) version of a document is for reference only. The English version shall prevail in case of any discrepancy between the translated and English versions.

21.4 Trademarks

Notice: All referenced brands, product names, service names and trademarks are the property of their respective owners.

I²C-bus — logo is a trademark of NXP Semiconductors N.V.

22. Contact information

For more information, please visit: <http://www.nxp.com>

For sales office addresses, please send an email to: salesaddresses@nxp.com

23. Tables

Table 1.	Ordering information	2
Table 2.	Marking codes	2
Table 3.	Pin description	5
Table 4.	Formatted registers overview	6
Table 5.	Control_status_1 - control and status register 1 (address 00h) bit description	7
Table 6.	Control_status_2 - control and status register 2 (address 01h) bit description	7
Table 7.	INT operation (bit TI_TP = 1) ^[1]	9
Table 8.	VL_seconds - seconds and clock integrity status register (address 02h) bit description	9
Table 9.	Seconds coded in BCD format	9
Table 10.	Minutes - minutes register (address 03h) bit description	10
Table 11.	Hours - hours register (address 04h) bit description	10
Table 12.	Days - days register (address 05h) bit description	10
Table 13.	Weekdays - weekdays register (address 06h) bit description	11
Table 14.	Weekday assignments	11
Table 15.	Century_months - century flag and months register (address 07h) bit description	11
Table 16.	Month assignments in BCD format	11
Table 17.	Years - years register (08h) bit description	12
Table 18.	Minute_alarm - minute alarm register (address 09h) bit description	13
Table 19.	Hour_alarm - hour alarm register (address 0Ah) bit description	14
Table 20.	Day_alarm - day alarm register (address 0Bh) bit description	14
Table 21.	Weekday_alarm - weekday alarm register (address 0Ch) bit description	14
Table 22.	CLKOUT_control - CLKOUT control register (address 0Dh) bit description	15
Table 23.	Timer_control - timer control register (address 0Eh) bit description	16
Table 24.	Timer - timer value register (address 0Fh) bit description	16
Table 25.	Timer register bits value range	16
Table 26.	First increment of time circuits after STOP bit release	19
Table 27.	Register reset value ^[1]	20
Table 28.	Limiting values	27
Table 29.	Static characteristics	28
Table 30.	Dynamic characteristics	30
Table 31.	SnPb eutectic process (from J-STD-020D)	37
Table 32.	Lead-free process (from J-STD-020D)	37
Table 33.	Abbreviations	38
Table 34.	Revision history	40

24. Figures

Fig 1.	Block diagram of PCF8563	3
Fig 2.	Pin configuration for HVSON10 (PCF8563BS)	4
Fig 3.	Pin configuration for SO8 (PCF8563T)	4
Fig 4.	Pin configuration for TSSOP8 (PCF8563TS)	4
Fig 5.	Interrupt scheme	8
Fig 6.	Voltage-low detection	10
Fig 7.	Data flow for the time function	12
Fig 8.	Access time for read/write operations	13
Fig 9.	Alarm function block diagram	15
Fig 10.	STOP bit functional diagram	18
Fig 11.	STOP bit release timing	18
Fig 12.	POR override sequence	20
Fig 13.	Bit transfer	21
Fig 14.	Definition of START and STOP conditions	21
Fig 15.	System configuration	22
Fig 16.	Acknowledgement on the I ² C-bus	22
Fig 17.	Slave address	23
Fig 18.	Master transmits to slave receiver (WRITE mode)	23
Fig 19.	Master reads after setting register address (write register address; READ data)	24
Fig 20.	Master reads slave immediately after first byte (READ mode)	24
Fig 21.	Interface watchdog timer	25
Fig 22.	Device diode protection diagram	26
Fig 23.	Supply current I _{DD} as a function of supply voltage V _{DD} ; CLKOUT disabled	29
Fig 24.	Supply current I _{DD} as a function of supply voltage V _{DD} ; CLKOUT = 32 kHz	29
Fig 25.	Supply current I _{DD} as a function of temperature T; CLKOUT = 32 kHz	30
Fig 26.	Frequency deviation as a function of supply voltage V _{DD}	30
Fig 27.	I ² C-bus timing waveforms	31
Fig 28.	Application diagram	32
Fig 29.	Package outline SOT650-1 (HVSON10) of PCF8563BS	33
Fig 30.	Package outline SOT96-1 (SO8) of PCF8563T	34
Fig 31.	Package outline SOT505-1 (TSSOP8) of PCF8563TS	35
Fig 32.	Temperature profiles for large and small components	38

25. Contents

1	General description	1	9.5	I ² C-bus protocol	23
2	Features and benefits	1	9.5.1	Addressing	23
3	Applications	1	9.5.2	Clock and calendar READ or WRITE cycles	23
4	Ordering information	2	9.6	Interface watchdog timer	25
5	Marking	2	10	Internal circuitry	26
6	Block diagram	3	11	Limiting values	27
7	Pinning information	4	12	Static characteristics	28
7.1	Pinning	4	13	Dynamic characteristics	30
7.2	Pin description	5	14	Application information	32
8	Functional description	6	14.1	Quartz frequency adjustment	32
8.1	CLKOUT output	6	14.1.1	Method 1: fixed OSC1 capacitor	32
8.2	Register organization	6	14.1.2	Method 2: OSC1 trimmer	32
8.3	Control registers	7	14.1.3	Method 3: OSC0 output	32
8.3.1	Register Control_status_1	7	15	Package outline	33
8.3.2	Register Control_status_2	7	16	Handling information	36
8.3.2.1	Interrupt output	8	17	Soldering of SMD packages	36
8.4	Time and date registers	9	17.1	Introduction to soldering	36
8.4.1	Register VL_seconds	9	17.2	Wave and reflow soldering	36
8.4.1.1	Voltage-low detector and clock monitor	10	17.3	Wave soldering	37
8.4.2	Register Minutes	10	17.4	Reflow soldering	37
8.4.3	Register Hours	10	18	Abbreviations	38
8.4.4	Register Days	10	19	References	39
8.4.5	Register Weekdays	11	20	Revision history	40
8.4.6	Register Century_months	11	21	Legal information	41
8.4.7	Register Years	12	21.1	Data sheet status	41
8.5	Setting and reading the time	12	21.2	Definitions	41
8.6	Alarm registers	13	21.3	Disclaimers	41
8.6.1	Register Minute_alarm	13	21.4	Trademarks	42
8.6.2	Register Hour_alarm	14	22	Contact information	42
8.6.3	Register Day_alarm	14	23	Tables	43
8.6.4	Register Weekday_alarm	14	24	Figures	44
8.6.5	Alarm flag	14	25	Contents	45
8.7	Register CLKOUT_control and clock output	15			
8.8	Timer function	16			
8.8.1	Register Timer_control	16			
8.8.2	Register Timer	16			
8.9	EXT_CLK test mode	17			
8.9.1	Operation example:	17			
8.10	STOP bit function	18			
8.11	Reset	19			
8.11.1	Power-On Reset (POR) override	20			
9	Characteristics of the I²C-bus	21			
9.1	Bit transfer	21			
9.2	START and STOP conditions	21			
9.3	System configuration	21			
9.4	Acknowledge	22			

Please be aware that important notices concerning this document and the product(s) described herein, have been included in section 'Legal information'.

© NXP Semiconductors N.V. 2015.

All rights reserved.

For more information, please visit: <http://www.nxp.com>

For sales office addresses, please send an email to: salesaddresses@nxp.com

Date of release: 26 October 2015

Document identifier: PCF8563

X-ON Electronics

Largest Supplier of Electrical and Electronic Components

Click to view similar products for [Real Time Clock](#) category:

Click to view products by [NXP](#) manufacturer:

Other Similar products are found below :

[DS1302Z-LF](#) [710029X](#) [879047C](#) [405800G](#) [PT7C43390LE](#) [RV-3029-C2-32.768k-OPTION-B-TB-QA](#) [RV-2123-C2-32.768k-20PPM-TA-QA](#) [RV-3029-C2-32.768k-OPTION-A-TB-QA](#) [RV-1805-C3-32.768k-2PPM-TA-QA](#) [RV-3029-C3-32.768k-OPTION-A-TB-QA](#) [RV-2123-C2-32.768kHz-20PPM-TA-QC](#) [RX-4035LC:B3 PURE SN](#) [RX-8564LC:B PURE SN](#) [RX-8803LCUB PURE SN BULK](#) [RX-8571LCB0 PURE SN](#) [BQ32002D](#) [RTC-8564JE](#) [MCP7940M-I/P](#) [DS3231SN#T&R](#) [DS1391U-18+](#) [DS1347T+T&R](#) [RX-8564LC:B3 PURE SN](#) [DS1338Z-33+T](#) [RX-4571SA:B3 PURE SN](#) [DS1340U-33+T&R](#) [RX-8571LC:B3 PURE SN](#) [PCF8583T/5.518](#) [S-35190A-J8T1U](#) [RTC-4543SAB](#) [RTC-72421A](#) [RTC-72423A](#) [RX-8803LC:UB3 PURE SN](#) [RX-8803SA:UB3 PURE SN](#) [S-35390A-T8T1](#) [AB1815-T3](#) [AB-RTCMC-32.768kHz-AIGZ-S7-T](#) [AB-RTCMC-32.768kHz-B5GA-S3-T](#) [AB-RTCMC-32.768kHz-B5ZE-S3-T](#) [AB-RTCMC-32.768kHz-EOA9-S3-D-B-T](#) [AB-RTCMC-32.768kHz-EOZ9-S3-D-B-T](#) [AB-RTCMC-32.768KHZ-EOZ9-S3-HAT](#) [AB-RTCMC-32.768KHZ-IBO5-S3-T](#) [AB-RTCMC-32.768kHz-ZIZE-S2-T](#) [DS1672U-33+](#) [DS1372U+](#) [DS1337U+T&R](#) [DS1340U-18+](#) [DS1339BU+](#) [DS1339AU+](#) [DS1339U-2+](#)