

Important notice

Dear Customer,

On 7 February 2017 the former NXP Standard Product business became a new company with the tradename **Nexperia**. Nexperia is an industry leading supplier of Discrete, Logic and PowerMOS semiconductors with its focus on the automotive, industrial, computing, consumer and wearable application markets

In data sheets and application notes which still contain NXP or Philips Semiconductors references, use the references to Nexperia, as shown below.

Instead of <http://www.nxp.com>, <http://www.philips.com/> or <http://www.semiconductors.philips.com/>, use <http://www.nexperia.com>

Instead of sales.addresses@www.nxp.com or sales.addresses@www.semiconductors.philips.com, use salesaddresses@nexperia.com (email)

Replace the copyright notice at the bottom of each page or elsewhere in the document, depending on the version, as shown below:

- © NXP N.V. (year). All rights reserved or © Koninklijke Philips Electronics N.V. (year). All rights reserved

Should be replaced with:

- © **Nexperia B.V. (year). All rights reserved.**

If you have any questions related to the data sheet, please contact our nearest sales office via e-mail or telephone (details via salesaddresses@nexperia.com). Thank you for your cooperation and understanding,

Kind regards,

Team Nexperia

DATA SHEET

**PMEGX10BEA;
PMEGX10BEV**

1 A very low V_F MEGA Schottky
barrier rectifier

Product data sheet
Supersedes data of 2004 Apr 02

2004 Jun 14

1 A very low V_F MEGA Schottky barrier rectifier

PMEGXX10BEA; PMEGXX10BEV

FEATURES

- Forward current: 1 A
- Reverse voltages: 20 V, 30 V, 40 V
- Very low forward voltage
- Ultra small and very small plastic SMD package
- Power dissipation comparable to SOT23.

APPLICATIONS

- High efficiency DC-to-DC conversion
- Voltage clamping
- Protection circuits
- Low voltage rectification
- Blocking diodes
- Low power consumption applications.

DESCRIPTION

Planar Maximum Efficiency General Application (MEGA) Schottky barrier rectifier with an integrated guard ring for stress protection, encapsulated in a very small SOD323 (SC-76) and ultra small SOT666 SMD plastic package.

MARKING

TYPE NUMBER	MARKING CODE
PMEG2010BEA	V1
PMEG3010BEA	V2
PMEG4010BEA	V3
PMEG2010BEV	G6
PMEG3010BEV	G5
PMEG4010BEV	G4

QUICK REFERENCE DATA

SYMBOL	PARAMETER	MAX.	UNIT
I_F	forward current	1	A
V_R	reverse voltage	20; 30; 40	V

PINNING

PIN	DESCRIPTION
PMEGXX10BEA (see Fig.1)	
1	cathode
2	anode
PMEGXX10BEV (see Fig.2)	
1, 2, 5, 6	cathode
3, 4	anode

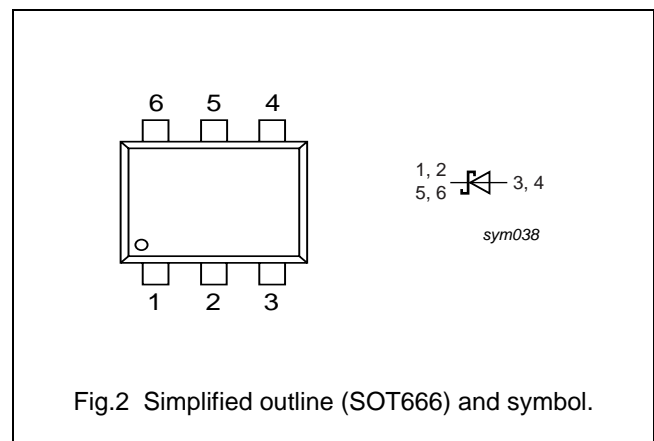
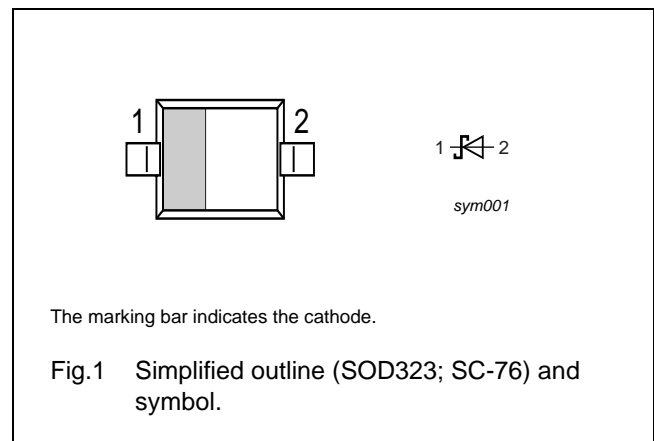

1 A very low V_F MEGA Schottky barrier rectifier

PMEGXX10BEA;
PMEGXX10BEV

ORDERING INFORMATION

TYPE NUMBER	PACKAGE		
	NAME	DESCRIPTION	VERSION
PMEGXX10BEA	–	plastic surface mounted package; 2 leads	SOD323
PMEGXX10BEV		plastic surface mounted package; 6 leads	SOT666

LIMITING VALUES

In accordance with the Absolute Maximum Rating System (IEC 60134).

SYMBOL	PARAMETER	CONDITIONS	MIN.	MAX.	UNIT
V_R	continuous reverse voltage PMEG2010BEA/PMEG2010BEV PMEG3010BEA/PMEG3010BEV PMEG4010BEA/PMEG4010BEV		–	20 30 40	V V V
I_F	continuous forward current	$T_s \leq 55\text{ °C}$; note 1	–	1	A
I_{FRM}	repetitive peak forward current	$t_p \leq 1\text{ ms}$; $\delta \leq 0.5$; note 2	–	3.5	A
I_{FSM}	non-repetitive peak forward current	$t_p = 8\text{ ms}$; square wave; note 2	–	10	A
T_j	junction temperature	note 3	–	150	°C
T_{amb}	operating ambient temperature	note 3	–65	+150	°C
T_{stg}	storage temperature		–65	+150	°C

Notes

1. Refer to SOD323 (SC-76) and SOT666 standard mounting conditions.
2. Only valid if pins 3 and 4 are connected in parallel (SOT666 package).
3. For Schottky barrier diodes thermal runaway has to be considered, as in some applications the reverse power losses P_R are a significant part of the total power losses. Nomograms for determining the reverse power losses P_R and $I_{F(AV)}$ rating will be available on request.

1 A very low V_F MEGA Schottky barrier rectifier

PMEGXX10BEA;
PMEGXX10BEV

THERMAL CHARACTERISTICS

SYMBOL	PARAMETER	CONDITIONS	VALUE	UNIT
PMEGXX10BEA (SOD323)				
$R_{th(j-a)}$	thermal resistance from junction to ambient	in free air; notes 1 and 2	450	K/W
		in free air; notes 2 and 3	210	K/W
$R_{th(j-s)}$	thermal resistance from junction to soldering point	note 4	90	K/W
PMEGXX10BEV (SOT666)				
$R_{th(j-a)}$	thermal resistance from junction to ambient	in free air; notes 2 and 5	405	K/W
		in free air; notes 2 and 6	215	K/W
$R_{th(j-s)}$	thermal resistance from junction to soldering point	note 4	80	K/W

Notes

1. Refer to SOD323 (SC-76) standard mounting conditions.
2. For Schottky barrier diodes thermal runaway has to be considered, as in some applications the reverse power losses P_R are a significant part of the total power losses. Nomograms for determining the reverse power losses P_R and $I_{F(AV)}$ rating will be available on request.
3. Device mounted on an FR4 printed-circuit board with copper clad 10×10 mm.
4. Solder point of cathode tab.
5. Refer to SOT666 standard mounting conditions.
6. Only valid if pins 3 and 4 are connected in parallel (SOT666 package).

CHARACTERISTICS

$T_{amb} = 25$ °C unless otherwise specified.

SYMBOL	PARAMETER	CONDITIONS	PMEG2010BEA/ PMEG2010BEV		PMEG3010BEA/ PMEG3010BEV		PMEG4010BEA/ PMEG4010BEV		UNIT
			TYP.	MAX.	TYP.	MAX.	TYP.	MAX.	
V_F	forward voltage	$I_F = 0.1$ mA	90	130	90	130	95	130	mV
		$I_F = 1$ mA	150	190	150	200	155	210	mV
		$I_F = 10$ mA	210	240	215	250	220	270	mV
		$I_F = 100$ mA	280	330	285	340	295	350	mV
		$I_F = 500$ mA	355	390	380	430	420	470	mV
		$I_F = 1000$ mA	420	500	450	560	540	640	mV
I_R	continuous reverse current	$V_R = 10$ V; note 1	15	40	12	30	7	20	μ A
		$V_R = 20$ V; note 1	40	200	–	–	–	–	μ A
		$V_R = 30$ V; note 1	–	–	40	150	–	–	μ A
		$V_R = 40$ V; note 1	–	–	–	–	30	100	μ A
C_d	diode capacitance	$V_R = 1$ V; $f = 1$ MHz	66	80	55	70	43	50	pF

Note

1. Pulse test: $t_p \leq 300$ μ s; $\delta \leq 0.02$.

1 A very low V_F MEGA Schottky barrier rectifier

PMEGXX10BEA;
PMEGXX10BEV

GRAPHICAL DATA

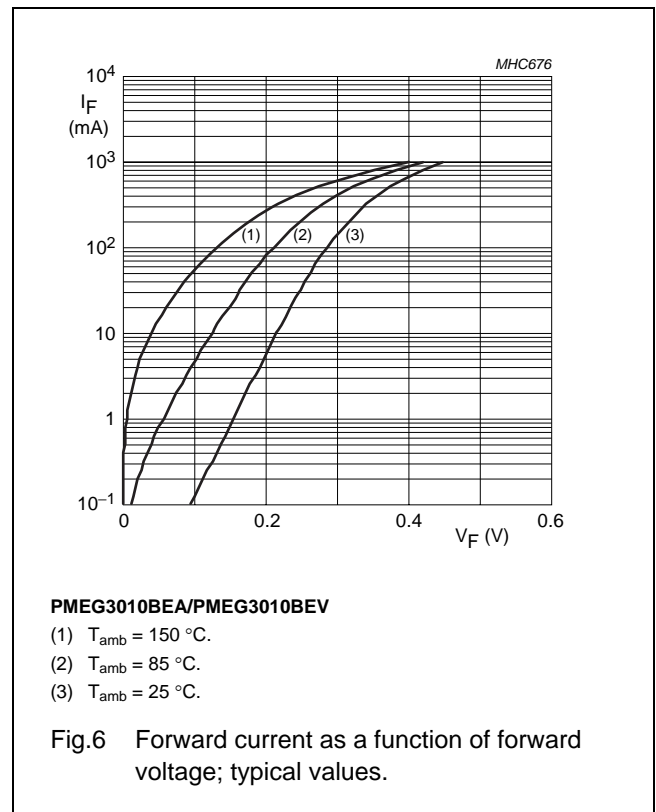
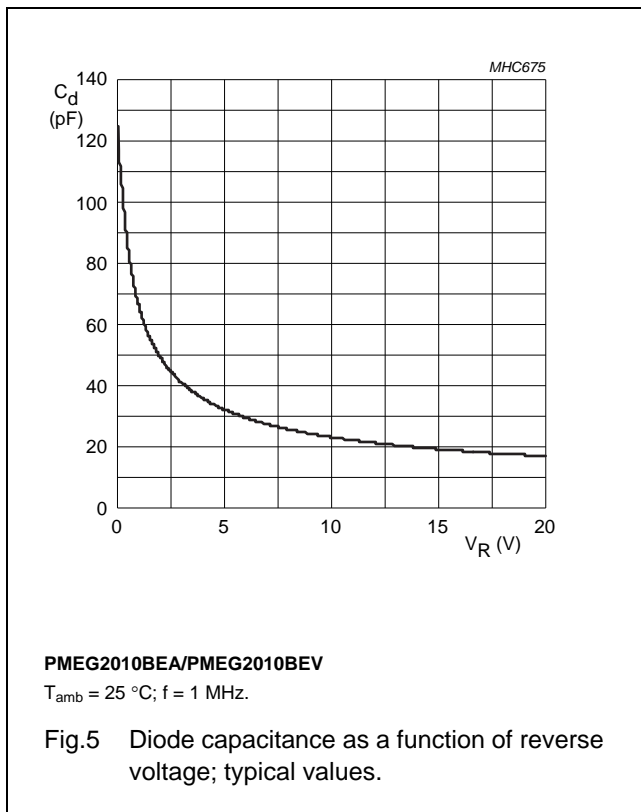
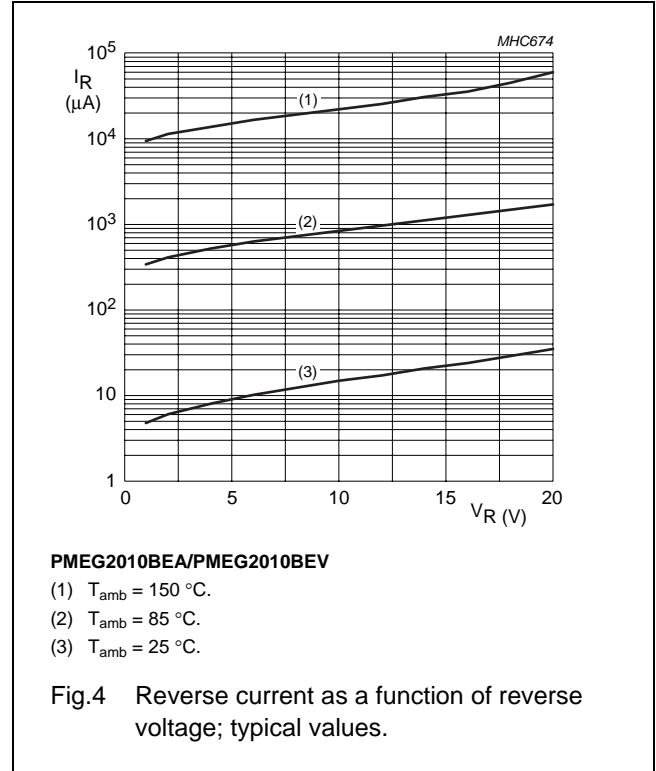
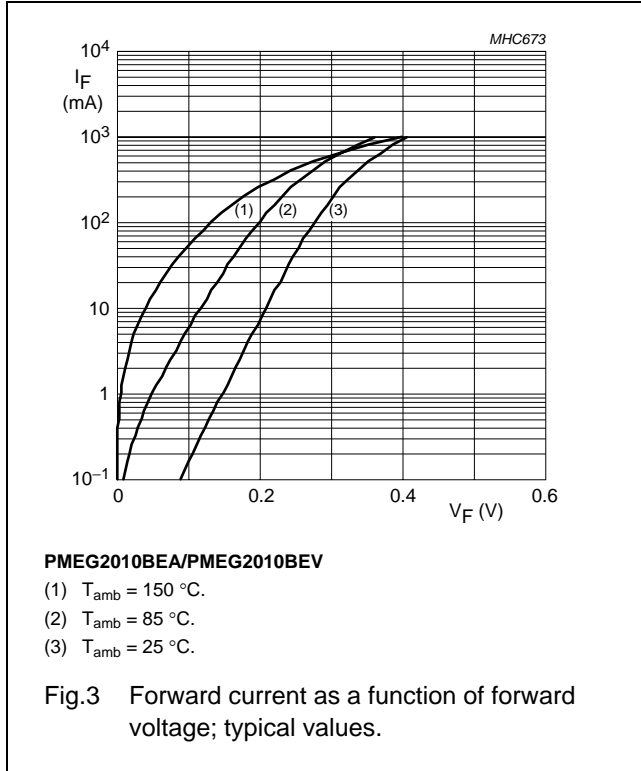

1 A very low V_F MEGA Schottky barrier rectifier

PMEGXX10BEA;
PMEGXX10BEV

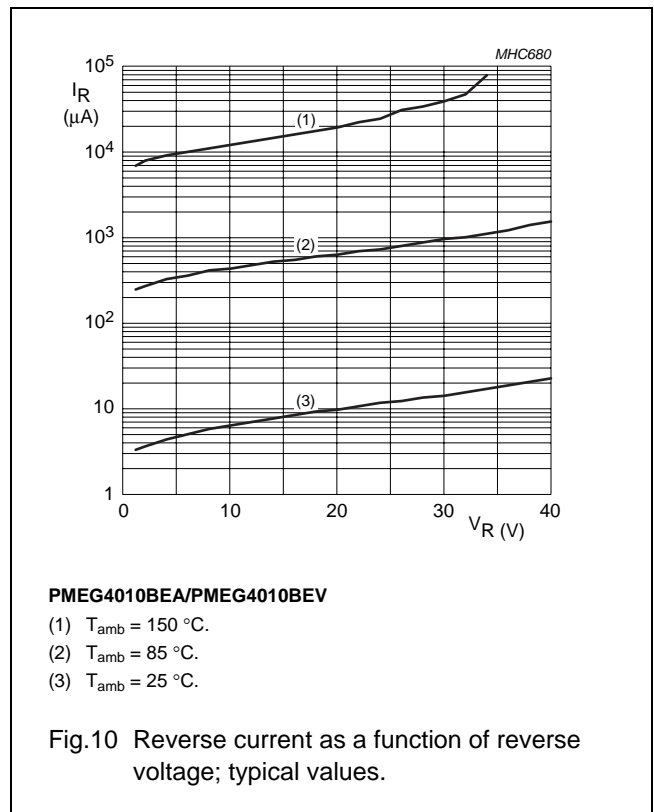
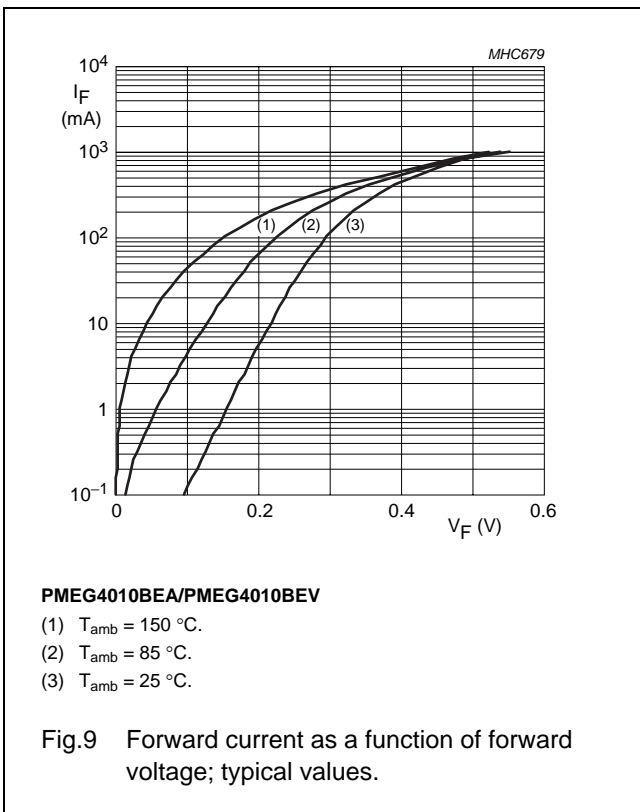
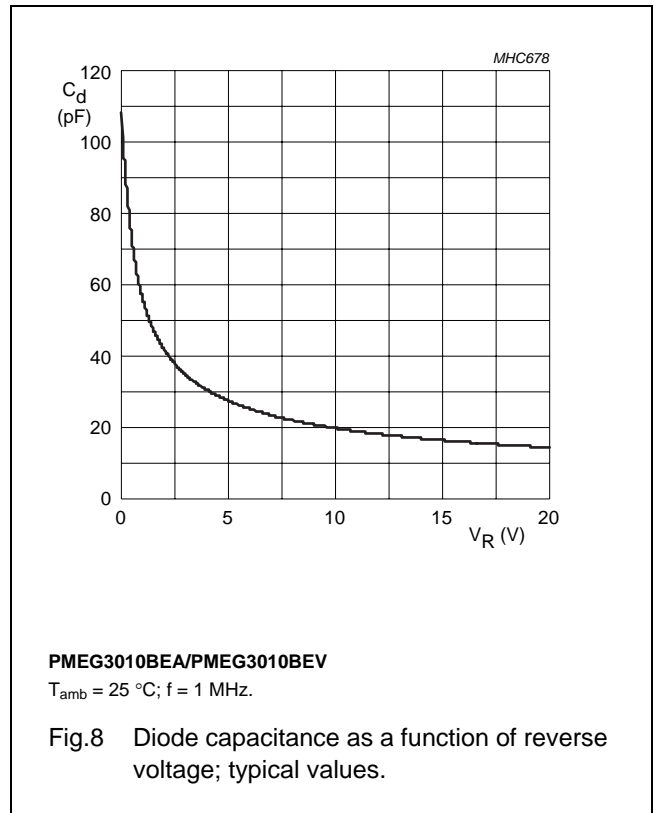
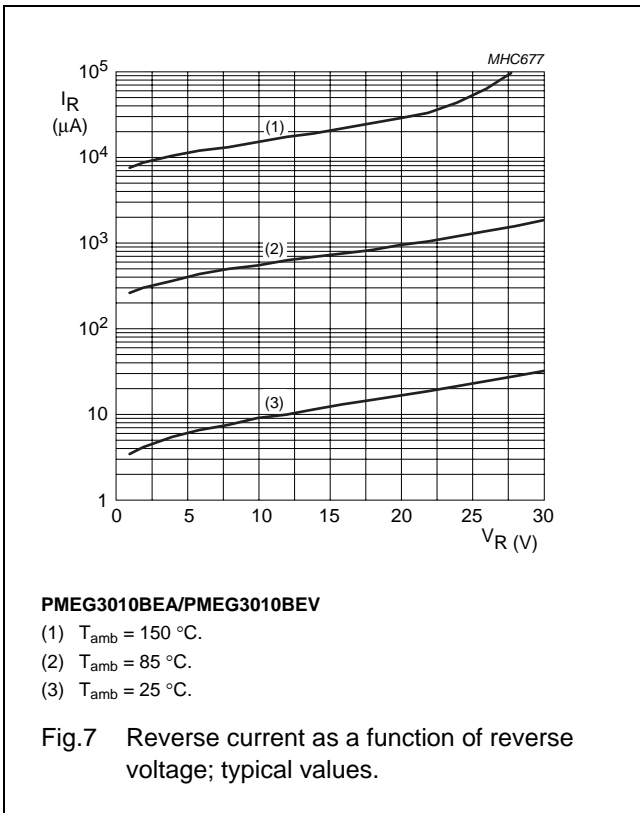

1 A very low V_F MEGA Schottky barrier rectifier

PMEGXX10BEA;
PMEGXX10BEV

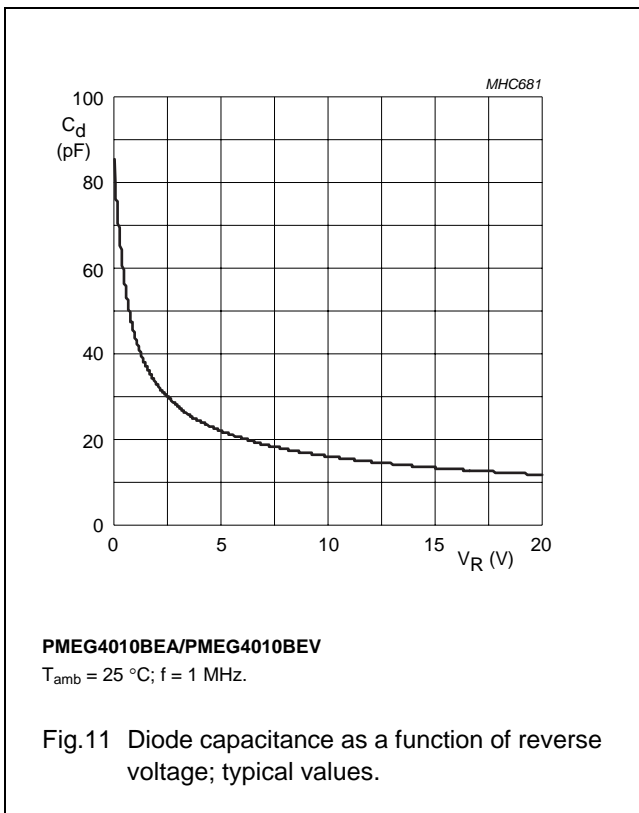

1 A very low V_F MEGA Schottky barrier rectifier

PMEGXX10BEA;
PMEGXX10BEV

PACKAGE OUTLINES

Plastic surface-mounted package; 2 leads

SOD323

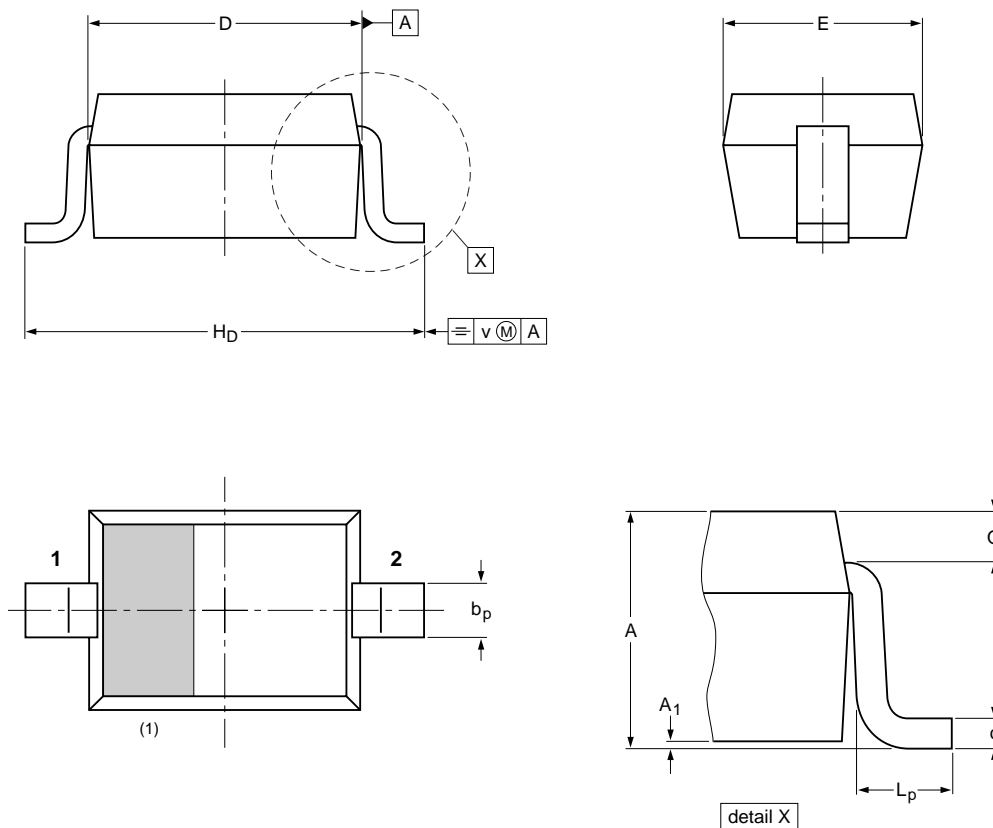

DIMENSIONS (mm are the original dimensions)

UNIT	A	A ₁ max	b _p	c	D	E	H _D	L _p	Q	v
mm	1.1 0.8	0.05	0.40 0.25	0.25 0.10	1.8 1.6	1.35 1.15	2.7 2.3	0.45 0.15	0.25 0.15	0.2

Note

1. The marking bar indicates the cathode

OUTLINE VERSION	REFERENCES			EUROPEAN PROJECTION	ISSUE DATE
	IEC	JEDEC	JEITA		
SOD323			SC-76		03-12-17 06-03-16

1 A very low V_F MEGA Schottky barrier rectifier

PMEGXX10BEA;
PMEGXX10BEV

Plastic surface-mounted package; 6 leads

SOT666

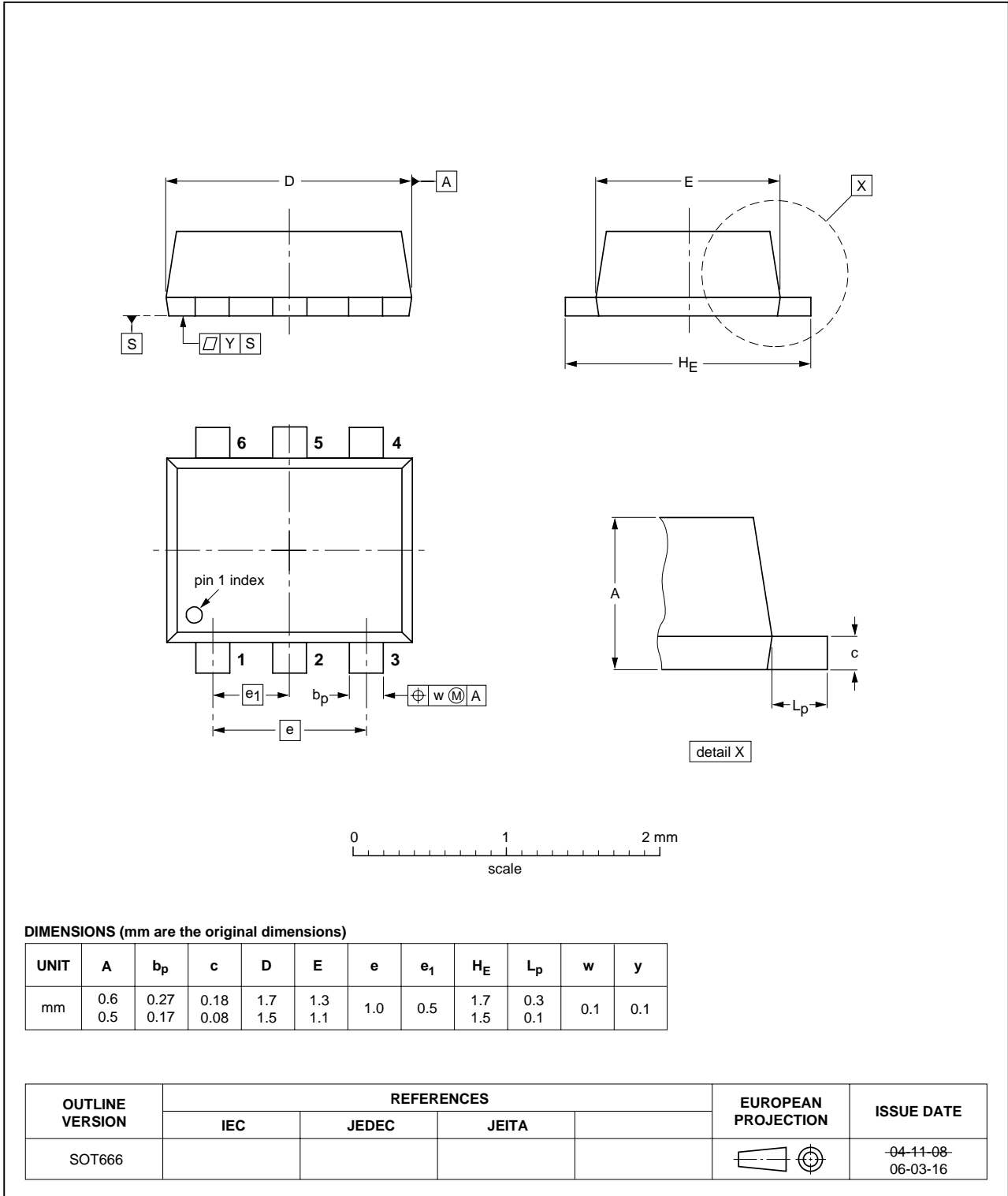

1 A very low V_F MEGA Schottky barrier rectifier

PMEGXX10BEA;
PMEGXX10BEV

DATA SHEET STATUS

DOCUMENT STATUS ⁽¹⁾	PRODUCT STATUS ⁽²⁾	DEFINITION
Objective data sheet	Development	This document contains data from the objective specification for product development.
Preliminary data sheet	Qualification	This document contains data from the preliminary specification.
Product data sheet	Production	This document contains the product specification.

Notes

1. Please consult the most recently issued document before initiating or completing a design.
2. The product status of device(s) described in this document may have changed since this document was published and may differ in case of multiple devices. The latest product status information is available on the Internet at URL <http://www.nxp.com>.

DISCLAIMERS

General — Information in this document is believed to be accurate and reliable. However, NXP Semiconductors does not give any representations or warranties, expressed or implied, as to the accuracy or completeness of such information and shall have no liability for the consequences of use of such information.

Right to make changes — NXP Semiconductors reserves the right to make changes to information published in this document, including without limitation specifications and product descriptions, at any time and without notice. This document supersedes and replaces all information supplied prior to the publication hereof.

Suitability for use — NXP Semiconductors products are not designed, authorized or warranted to be suitable for use in medical, military, aircraft, space or life support equipment, nor in applications where failure or malfunction of an NXP Semiconductors product can reasonably be expected to result in personal injury, death or severe property or environmental damage. NXP Semiconductors accepts no liability for inclusion and/or use of NXP Semiconductors products in such equipment or applications and therefore such inclusion and/or use is at the customer's own risk.

Applications — Applications that are described herein for any of these products are for illustrative purposes only. NXP Semiconductors makes no representation or warranty that such applications will be suitable for the specified use without further testing or modification.

Limiting values — Stress above one or more limiting values (as defined in the Absolute Maximum Ratings System of IEC 60134) may cause permanent damage to the device. Limiting values are stress ratings only and operation of the device at these or any other conditions

above those given in the Characteristics sections of this document is not implied. Exposure to limiting values for extended periods may affect device reliability.

Terms and conditions of sale — NXP Semiconductors products are sold subject to the general terms and conditions of commercial sale, as published at <http://www.nxp.com/profile/terms>, including those pertaining to warranty, intellectual property rights infringement and limitation of liability, unless explicitly otherwise agreed to in writing by NXP Semiconductors. In case of any inconsistency or conflict between information in this document and such terms and conditions, the latter will prevail.

No offer to sell or license — Nothing in this document may be interpreted or construed as an offer to sell products that is open for acceptance or the grant, conveyance or implication of any license under any copyrights, patents or other industrial or intellectual property rights.

Export control — This document as well as the item(s) described herein may be subject to export control regulations. Export might require a prior authorization from national authorities.

Quick reference data — The Quick reference data is an extract of the product data given in the Limiting values and Characteristics sections of this document, and as such is not complete, exhaustive or legally binding.

NXP Semiconductors

Customer notification

This data sheet was changed to reflect the new company name NXP Semiconductors, including new legal definitions and disclaimers. No changes were made to the technical content, except for package outline drawings which were updated to the latest version.

Contact information

For additional information please visit: <http://www.nxp.com>

For sales offices addresses send e-mail to: salesaddresses@nxp.com

© NXP B.V. 2009

All rights are reserved. Reproduction in whole or in part is prohibited without the prior written consent of the copyright owner.

The information presented in this document does not form part of any quotation or contract, is believed to be accurate and reliable and may be changed without notice. No liability will be accepted by the publisher for any consequence of its use. Publication thereof does not convey nor imply any license under patent- or other industrial or intellectual property rights.

Printed in The Netherlands

R76/04/pp11

Date of release: 2004 Jun 14

Document order number: 9397 750 13234

founded by

PHILIPS

X-ON Electronics

Largest Supplier of Electrical and Electronic Components

Click to view similar products for [Rectifiers](#) category:

Click to view products by [NXP](#) manufacturer:

Other Similar products are found below :

[D91A](#) [DA24F4100L](#) [DD89N1600K-A](#) [DD89N16K-K](#) [RL252-TP](#) [DLA11C-TR-E](#) [DSA17G](#) [1N4005-TR](#) [BAV199-TP](#) [UFS120Je3/TR13](#)
[JANS1N6640US](#) [VS-80-1293](#) [DD89N16K](#) [DD89N16K-A](#) [481235F](#) [DSP10G-TR-E](#) [RRE02VS6SGTR](#) [067907F](#) [MS306](#) [ND104N08K](#)
[SPA2003-B-D-A01](#) [VS-80-6193](#) [VS-66-9903](#) [VGF0136AB](#) [US2JFL-TP](#) [UFS105Je3/TR13](#) [A1N5404G-G](#) [ACGRA4007-HF](#) [ACGRB207-HF](#)
[RF301B2STL](#) [RF501B2STL](#) [UES1306](#) [UES1302](#) [BAV199E6433HTMA1](#) [ACGRC307-HF](#) [ACEFC304-HF](#) [JANTXV1N5660A](#) [UES1106](#)
[GS2K-LTP](#) [D126A45C](#) [D251N08B](#) [SCHJ22.5K](#) [SM100](#) [SCPA2](#) [SCH10000](#) [SDHD5K](#) [STTH20P035FP](#) [VS-8EWS12S-M3](#) [VS-](#)
[12FL100S10](#) [ACGRA4001-HF](#)