

# AN11470

## Leadless Schottky diodes in a DC-to-DC step-up converter

Rev. 1 — 22 April 2014

Application note

### Document information

Info	Content
<b>Keywords</b>	Schottky diode, boost converter, LED backlight, current source
<b>Abstract</b>	<p>This application note discusses the application of DC-to-DC voltage up conversion with focus on the Schottky diode used in the backlight unit of typical mobile devices. Products equipped with a Liquid Crystal Display (LCD) such as smartphones, tablet PCs or notebooks need backlight for the illumination. Strings of LEDs are the standard solution for an energy efficient light generation. The LED strings need to be supplied with a defined current. The voltage required for the strings is a multiple of the forward voltage of the LEDs used. The main supply voltage of mobile devices, e.g. from a lithium-ion battery pack, is not high enough to run a current through the LED string. Therefore a voltage booster is required. Requirements for the Schottky diode in this booster with respect to electrical and thermal performance are discussed in detail. NXP Semiconductors Schottky diodes allow to replace diodes in comparably large packages with very small components and enable a further step towards miniaturization without compromising performance.</p>



## Revision history

Rev	Date	Description
1	20140422	Initial version

## Contact information

For more information, please visit: <http://www.nxp.com>

For sales office addresses, please send an email to: [salesaddresses@nxp.com](mailto:salesaddresses@nxp.com)

## 1. Introduction

---

Most of the mobile communication and computing devices like mobile phones, tablet PCs, navigation systems and notebooks use LCDs. An LCD display needs backlight that is placed behind the LCD shutter system. For each pixel of the display LCD crystals can block light transmission when a black pixel is displayed or they let light pass to generate e.g. a white pixel. The degree of transmissibility is controlled for each pixel to allow gray level in between. In modern LCD devices white LEDs are chosen as an energy efficient light source. They combine advantages like a long life time, a constant white temperature over time and low heat dissipation. The light produced by LEDs is distributed with plastic light spreaders to achieve a uniform brightness for all areas of the display. White LEDs have a forward voltage  $V_F$  of 3.2 V to 3.6 V. The LEDs are clustered into strings, where a defined number of LEDs is placed in series to build a string. The forward voltage of a string is the multiple of  $V_F$  of a single LED.

The supply voltage of mobile devices is usually lower than the voltage required to drive LED strings for the LCD backlight. In smartphones normally a single lithium-ion cell provides roughly 3.8 V. Therefore a voltage up conversion or a boosting of the battery voltage towards a suitable voltage of the backlight is required. The voltage conversion has to work like the LEDs themselves with a high energy efficiency. Furthermore small and low weight components have to be chosen for the circuits.

The voltage up conversion is usually implemented in a switch mode topology. The conversion block requires an electronic switch, a diode, an inductor and a capacitor as discrete key components.

This application note focuses on the Schottky diodes that can be found in backlight step-up converters. New package technologies and enhanced Schottky processes allow more compact designs in combination with an excellent energy efficiency.

## 2. Methods of DC-to-DC voltage up conversion

### 2.1 Voltage up conversion based on charge pumps

There are several technical options how to convert a low DC input voltage  $V_I$  to a higher output voltage  $V_O$ . One possibility is to use a transformer where the primary winding is connected to a chopper circuit. At the secondary side the output voltage needs to be rectified. Such a transformer approach requires two coupled coils and therefore too much heavy material. Galvanic decoupling is a feature of this solution, but not required for a backlight booster in mobile devices.

Another solution for voltage up conversion is a charge pump. [Figure 1](#) depicts a circuit that can provide an output voltage twice as high as the input voltage in case of ideal components. With real components the forward voltage drop of the diodes leads to a lower output voltage. Assuming the switch SW is connected to the ground GND, capacitor C1 is charged to  $V_I - V_F$  via the diode D1, capacitor C2 reaches the voltage  $V_I - 2 \times V_F$  via the diode D2. When the switch is connected to  $V_I$  now, the charged capacitor C1 gets connected to this higher reference point. Now charge can flow into C2 via D2 while D1 is blocking in reverse direction. If the switch is connected to the ground again, C1 is recharged and D2 is driven in reverse direction, because the voltage at C2 is higher than  $V_I$ . After some switching cycles the output voltage equals:

$$V_O = 2 \times (V_I - V_F)$$

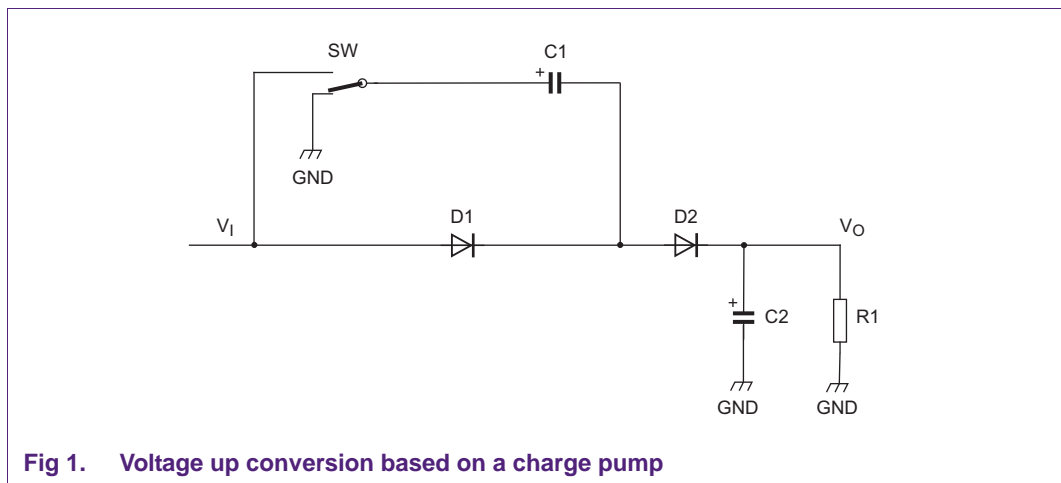

Fig 1. Voltage up conversion based on a charge pump

Figure 2 shows an extension of the above described circuit. This structure can be used to achieve a triplication of the input voltage. The circuit depicted in Figure 1 is extended by two additional diodes D3 and D4 and two additional capacitors C3 and C4. The function of the voltage doubler has been explained already. The doubled voltage at C2 gets transferred via D3 and D4 to C4. Via the switched capacitor C3, an additional voltage of  $V_I$  is finally added at C4 after some switching cycles, assuming the ideal case that the diodes have no forward losses. In practice as diodes have a forward loss, the output voltage reaches only  $V_O = 3 \times V_I - 4 \times V_F$ . The voltage up converter discussed can be extended with further booster stages. This way charge pump principle can be used to achieve a boosting factor of  $n$  if  $2 \times (n - 1)$  diodes and capacitors are arranged according to the structure explained above. The general formula for  $V_O$  and a boosting factor  $n$  is:

$$V_O = n \times V_I - 2 \times V_F \times (n - 1)$$

A disadvantage of the circuit introduced is that the forward losses of the diodes have a comparably big impact on the boosting factor, if the input voltage is quite small. Generally the number of components increases if a bigger boosting factor is required. Furthermore the structure is suitable for rather small load currents only. Therefore charge pump solutions can be found in applications such as gate voltage booster in synchronous voltage down converters, where a gate voltage on top of  $V_I$  is required for the high-side switch (see Ref. 1 “Application Note AN11119 Medium power small-signal MOSFETs in DC-to-DC conversion.”). Another application example of a charge pump is a voltage inverter used for an operational amplifier where a negative supply voltage shall be generated from a single positive supply. In Integrated Circuit (IC) designs synchronous rectification can be found, in which MOSFETs parallel to the Schottky diodes are switched on at the moment where the diodes are in forward conduction mode. This can reduce the losses of the charge pump design significantly.

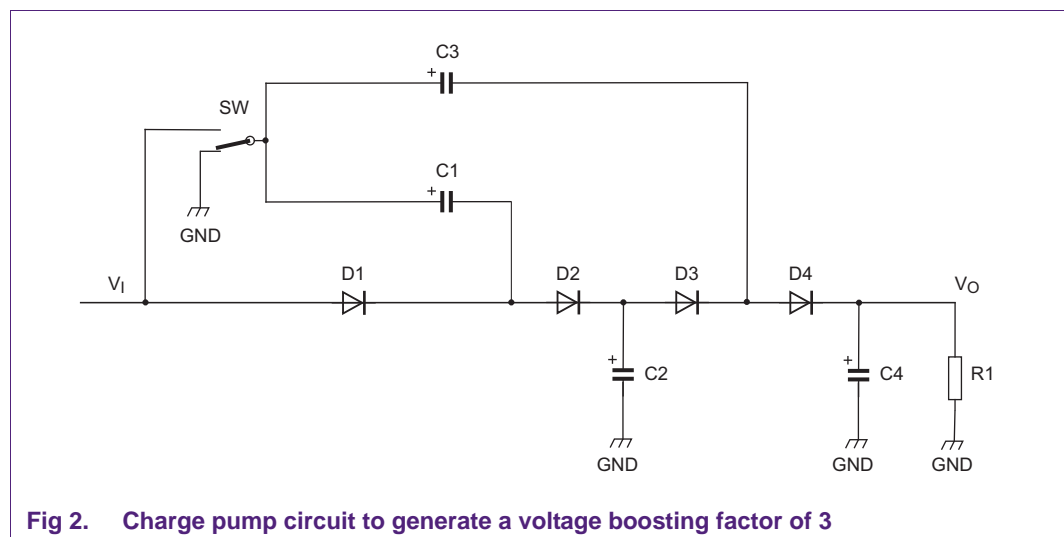

Fig 2. Charge pump circuit to generate a voltage boosting factor of 3

### 2.2 Inductor-based voltage up converter

The major part of voltage boosters is based on an inductor, used to store energy in the process of the voltage up conversion. The standard topology is quite simple as shown on [Figure 3](#). It consists of an inductor L1 that is connected to a supply voltage at one side and can be switched to the ground via the low-side MOSFET switch Q1. From the switching node the diode D1 builds a path to the output capacitor C2. Assuming ideal and lossless components, the output capacitor gets charged to  $V_I$  once the input supply is turned on. If Q1 is switched on, the current through the inductor increases linearly and magnetic energy is stored. The amount of energy is:

$$E = \frac{1}{2} \times L \times I^2$$

The current increases if losses are neglected by  $\Delta I$ :

$$\Delta I = \frac{1}{L} \times V_I \times t_{on}$$

The diode is driven in reverse direction, this means that it blocks a current flow. The anode is connected to the ground and the cathode voltage is  $V_O$ . If the switch is turned off, the current through the inductor continues to flow in the same direction and the diode works in forward. Charge is transferred into the output capacitor. The inductor current decreases with a linear curve ( $I \geq 0$  A):

$$\Delta I = 1L \times (V_O - V_I) \times t_{off}$$

The current through the inductor has a triangular waveform. If the current stays larger than 0 A for all the time in the circuit, the operation condition is called continuous mode.

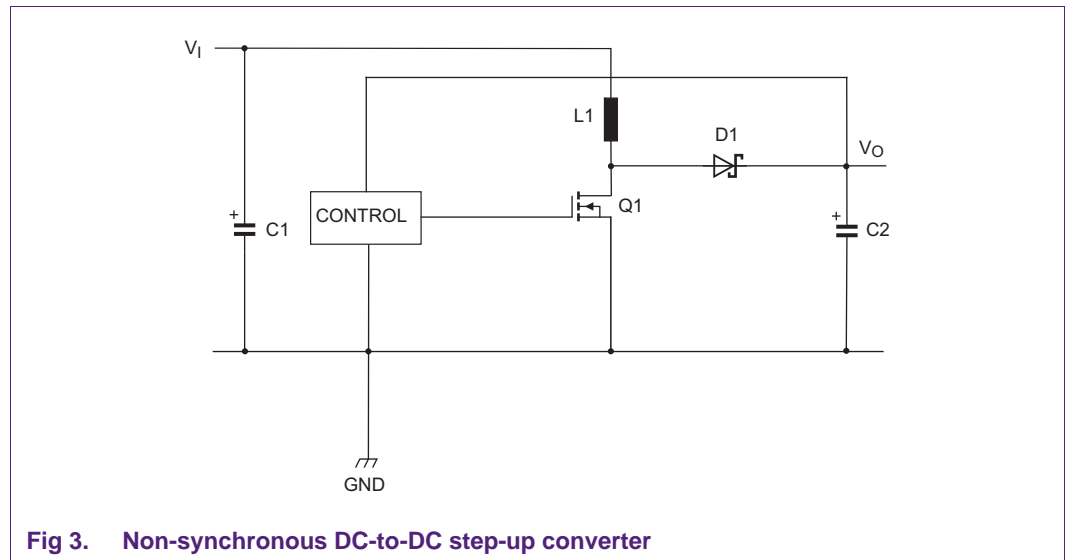

For  $\Delta I$  following equations can be used to calculate  $V_O$ :

$$V_O = V_I \times (t_{on} + t_{off}) / t_{off} \quad (1)$$

$$D = t_{on} / (t_{on} + t_{off}); T = t_{on} + t_{off} \quad (2)$$

$$V_O = V_I \times T / t_{off} = V_I \times T / (T - t_{on}) = V_I / (1 - D) \quad (3)$$

$$V_O = V_I / (1 - D) \quad (4)$$

The simple equation can be understood easily, if the corner cases for the duty cycle  $D$  are checked. If  $D$  is zero, this means the switch stays in off condition all the time,  $V_O$  is equal  $V_I$ . In practice the forward loss of the diode needs to be subtracted. If  $D$  is increased and gets close to 1, the output voltage reaches infinite values. In practice however the current through the inductance has to stay below a certain value, where a saturation of the magnetic material happens. Maximum drain current for the switching MOSFET indicates another limit. Furthermore the maximum voltage ratings of the diode, the MOSFET and the output capacitor needs to be obeyed. The control of the duty cycle is getting more and more tough if very high boosting factors are foreseen, because the curve of  $V_O$  versus  $D$  gets very steep if the duty cycle is close to 1. This means that the system reacts intensively with respect to  $V_O$  if the switching times are changed by a small step.

In [Figure 4](#) an example of a SPICE circuit diagram created with LTspice software of Linear Technology Corporation for a DC-to-DC step-up converter is shown. As a switch PMV16UN, a low  $R_{DSon}$  N-channel MOSFET is selected. Drain-source on-state resistance is typically  $R_{DSon} = 15 \text{ m}\Omega$  at a gate-source voltage  $V_{GS} = 4.5 \text{ V}$  only. As Schottky diode a PMEG3010ER is chosen. This diode has rated reverse voltage of  $V_R = 30 \text{ V}$  and continuous forward current of  $I_F = 1 \text{ A}$ . An output capacitor of  $100 \text{ }\mu\text{F}$  and a load resistor of  $25 \text{ }\Omega$  are applied.

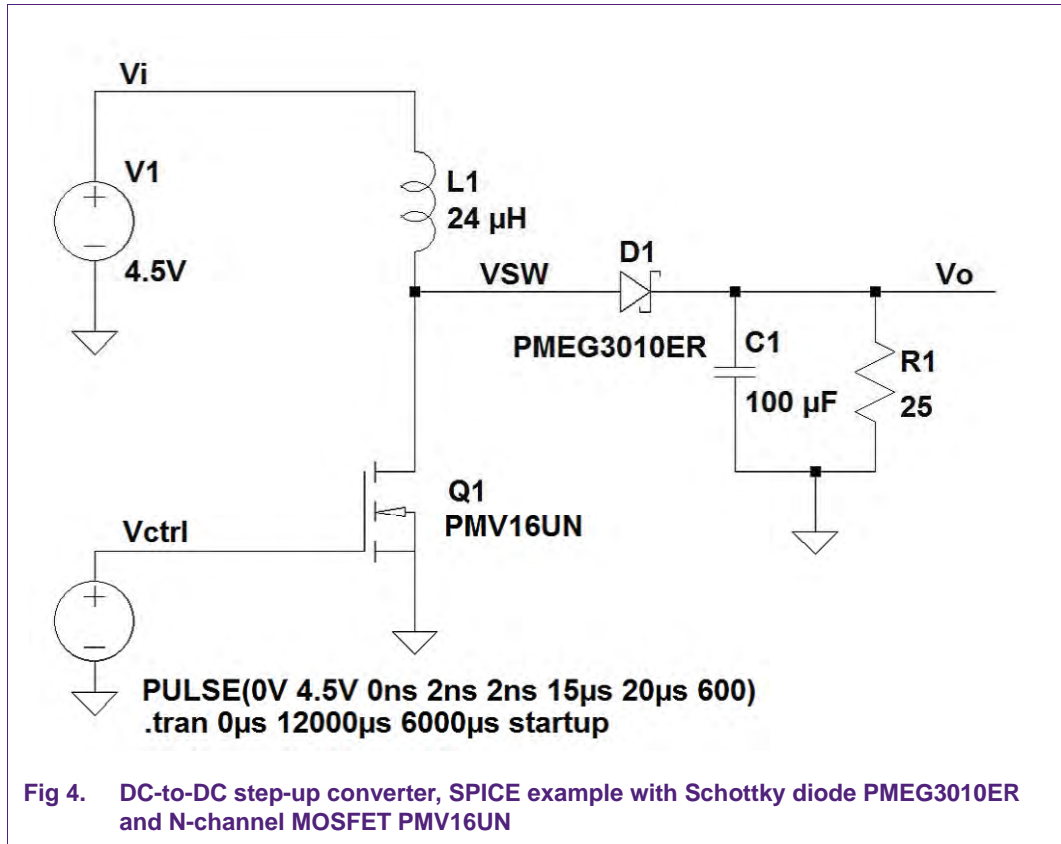

With supply voltage  $V_1 = 4.5\text{ V}$ , the MOSFET is switched by the source  $V_{ctrl}$ . This generates a gate control signal with 4.5 V high state level, 0 V low level and a frequency of 50 kHz. The duty cycle is 0.75. This means that the switch is turned on for 15  $\mu\text{s}$  per 20  $\mu\text{s}$  period time. Figure 5 shows the SPICE simulation results for this voltage booster example. The red curve is the voltage curve of the switching node. While the MOSFET is switched on, the voltage is close to ground. If the switch is turned off, the voltage jumps to  $V_O$ , plus the forward voltage of the diode on top. The inductor current is depicted in green (curve 3) and shows triangle waveform. While the switch is closed, the current increases linearly. During off-time of the switch, the current decreases linearly again. The output voltage is shown with the blue trace (curve 1). According to theory and the output voltage formula (4), for the ideal case:

$$V_O = 4,5 / (1 - 0,75) = 4,5 \times 4 = 18\text{V}$$

The simulation delivers 17.82 V as averaged value with the consideration of realistic components. This means that switching times are taken into account producing switching losses in the MOSFET. Furthermore the residual on-state resistance of the switch needs to be considered and the finite capacitance of the output capacitor.

The output current is  $I_O = 0.712\text{ A}$  DC current, if the small ripple is disregarded. The current through the diode is the part of the current through the inductor for the time the switch is opened. This is equivalent to the sections of the triangle-shaped waveform where the current decreases. The average value of the diode current (triangle + rectangular) needs to be identical to the output current. Therefore the average value for each current pulse has to be (pulse average):  $I_{D1} = I_O / (1 - D)$



If the current is adjusted to a value where the inductor current waveforms just touches the 0 A line, the system operates at the edge towards the continuous mode. In this case there is no rectangular content which needs to be added to the triangle.

For the peak current the equation can be defined:  $I_{DI_{max}} = 2 \times I_O / (1 - D)$

For this kind of operation there is the biggest factor between the output current and the peak current in the diode. The example shows that the diode in the voltage boosters works with comparably high currents, present at the time it is in conductive mode. The diode has to be chosen taking this fact into account. The operating point in the  $I_F - V_F$  diagram is located at much higher currents than the output current itself. Therefore a low  $V_F$  characteristic increases power efficiency a lot.

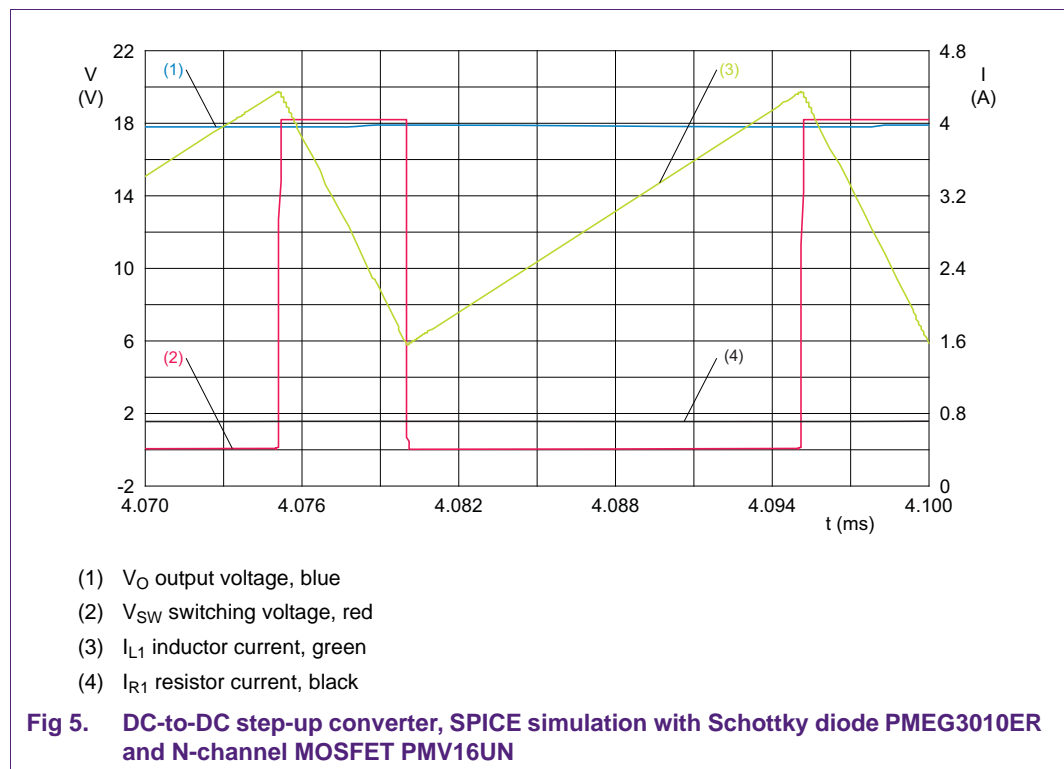

### 3. Demo PCB DC-to-DC step-up converter using very small Schottky diodes

#### 3.1 Hardware of the DC-to-DC step-up converter on demo PCB

To demonstrate the technical potential of NXP Semiconductors small package Schottky diodes a demo PCB for an LED booster has been designed. It can be supplied with an input voltage starting from 1.6 V. The input voltage is boosted based on a voltage up converter structure as explained in the last chapter. A controller LT1618 from Linear Technology Corporation is used for the switching task. It can work in constant current and voltage control mode. LT1618 was chosen as an easy to handle device with a low pin count. [Figure 6](#) shows the schematic diagram of the demo PCB.

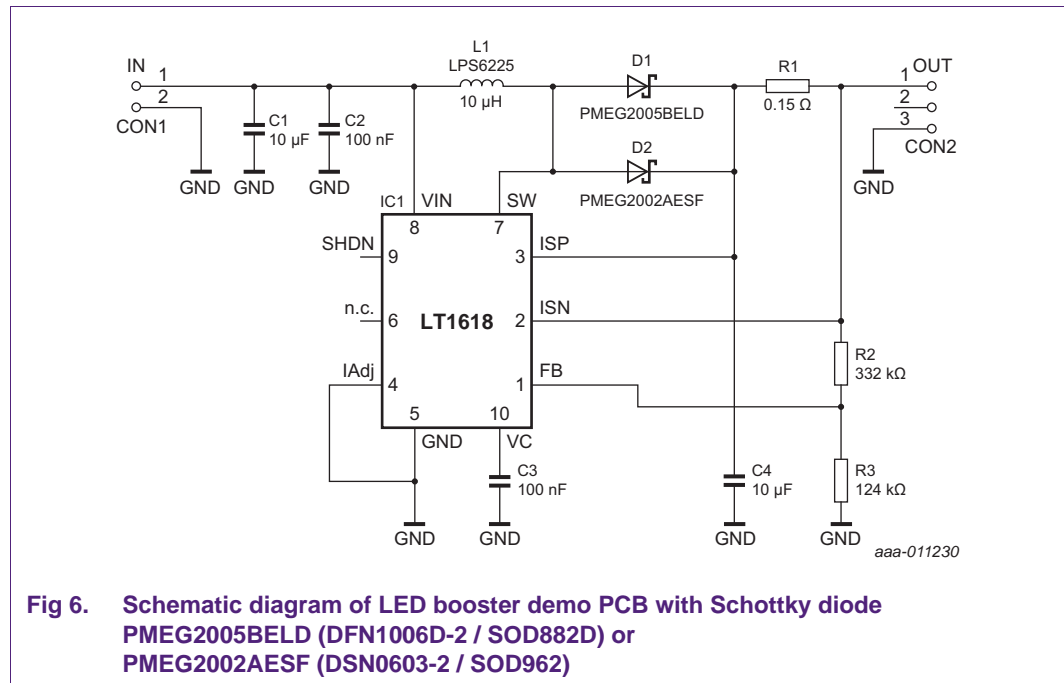

The LT1618 works with a constant switching frequency of 1.4 MHz. This allows the usage of small inductors and output capacitors. The operating voltage range is 1.6 V to 18 V. The switch in the LT1618 is realized with a bipolar transistor. The controller can support an output voltage control and an output current control. An inductance of 10 µH is selected for L1 and an output capacitor of 10 µF. For the booster diode function two footprints (D1 and D2) are available. Only one of these diodes shall be assembled. One diode is foreseen in an DFN1006D-2 (SOD882D) package with a size of 1 mm × 0.6 mm × 0.37 mm, the other assembly option is the smaller DSN0603-2 (SOD962) package with a size of 0.6 mm × 0.3 mm × 0.3 mm. R1 is the current sensing resistor. The current sensing voltage at R1 is limited to 50 mV by the current control of LT1618. This leads to the following equation for the output current:

$$I_O = 50mV/R1$$

With R1 = 0.15 Ω like on [Figure 6](#), the output current is set to 333 mA. This is the suitable current in case a 1 W power LED is foreseen as load for the demo PCB.

At the FeedBack (FB) pin the controller IC monitors the output voltage. Even if the board is run in a current source application an additional voltage control for the situation of an open output is an important safety feature. A simple current source would increase the output voltage if driven without any load or if driven with a more high-ohmic load than foreseen for the design. The high output voltage could damage the switching transistor inside the controller IC, exceed the maximum allowed reverse voltage of the Schottky diode or the voltage rating of the output capacitor C1. LT1618 limits the voltage at FB pin to 1.263 V. The output of the booster is connected via the resistor divider built by R2 and R3 to the FB pin. This leads to the following equation for  $V_O$ :

$$V_O = 1.263V \times (R2 + R3) / (R3)$$

In a current source application the voltage limiter should be set to an output voltage that is 20% to 30% higher than the voltage that a nominal LED load requires. This ensures that the current control does not interfere with the voltage control in the normal operation mode with a LED load. The voltage limitation is a good protection against too high voltages if a wrong load is applied to the booster. The dimensioning of the voltage feedback divider as defined in the schematic diagram on [Figure 6](#) leads to a maximum output voltage of about  $V_O = 4.64 V$ .

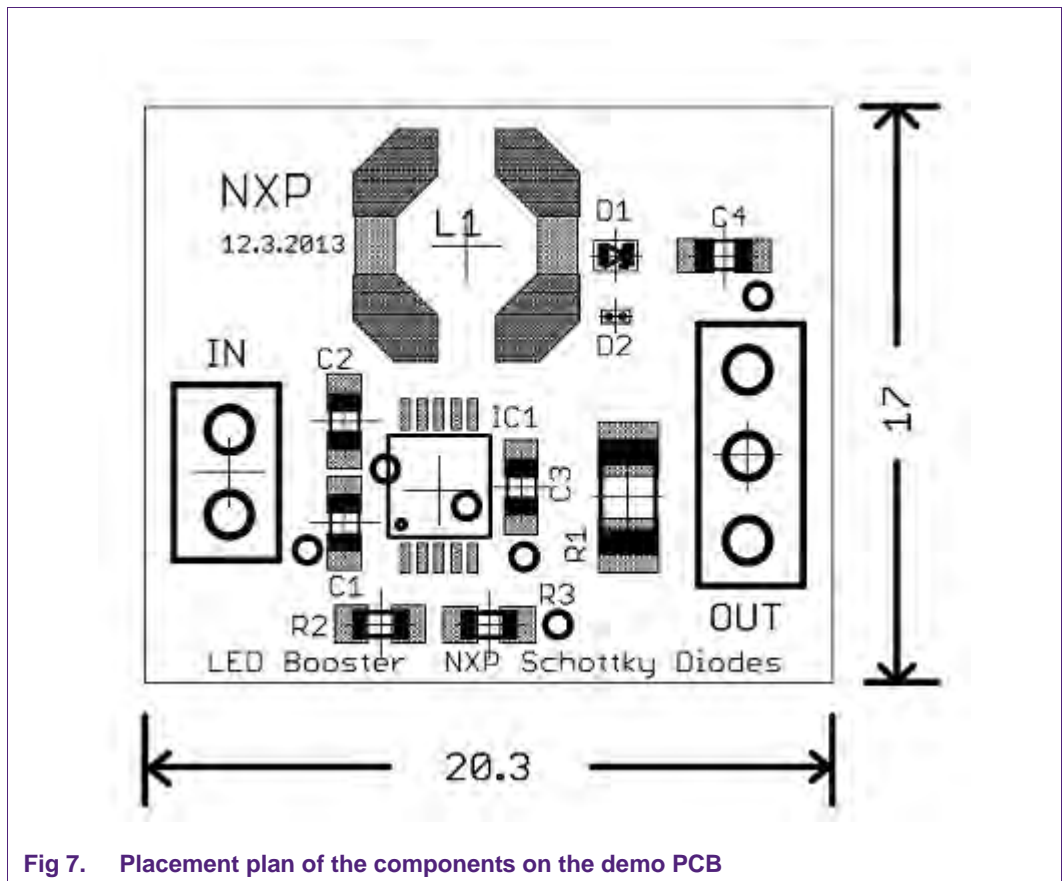
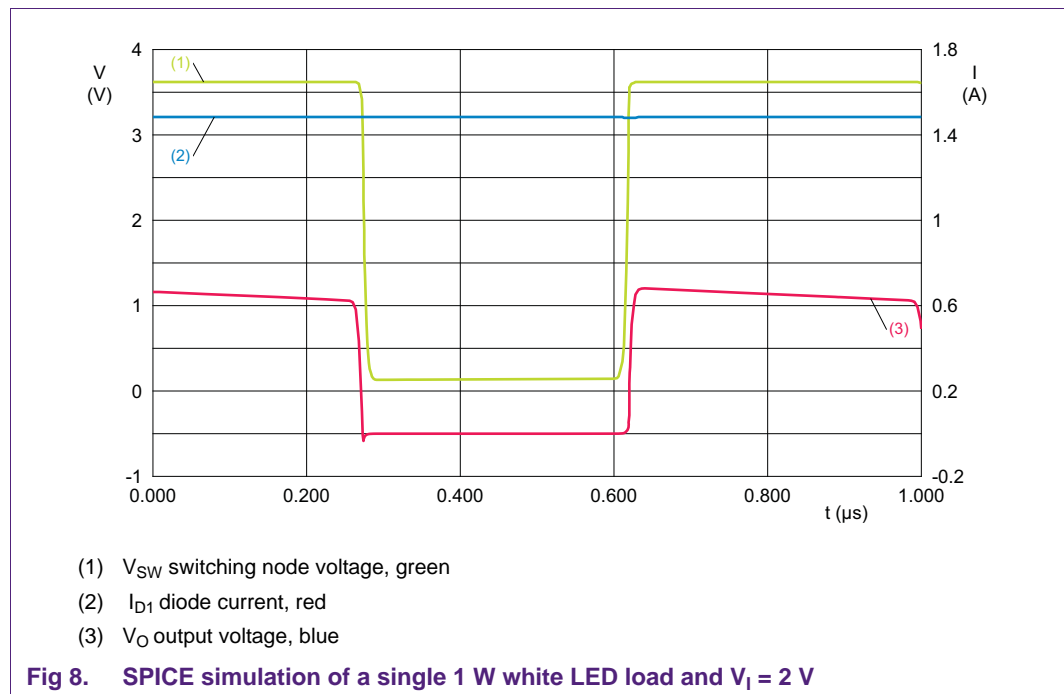

Fig 7. Placement plan of the components on the demo PCB

Figure 7 shows the placements of the components on the demo PCB. The input connector uses a two-pin plug, whereas the output uses 3 pins. In this way a risk of commutation for the external connections to the input supply and the LED load is avoided mechanically. For the set-up of the PCB it is important to take care that  $V_I$  is never higher than the programmed  $V_O$ . Otherwise a high current can flow directly via the Schottky diode D1 and the LED load due to the steep forward current versus forward voltage characteristics of both diode devices.

Figure 8 shows simulated traces for the use case where an input voltage  $V_I = 2\text{ V}$  is applied as input voltage and a 1 W white LED is connected as load. The booster diode simulated is the PMEG2005BELD. Curve 1 (green) shows the switching node SW according to Figure 6. Curve 2 (blue) is the output voltage, which is roughly  $V_O = 3.2\text{ V}$ . Curve 3 (red) depicts the current through the diode. The trace shows that the ripple is rather small with the 10  $\mu\text{H}$  inductor at the fixed switching frequency of 1.4 MHz.



In the SPICE schematic diagram in Figure 9 the output load has been changed to two LEDs in series. R3 needs to be adapted to allow a higher output voltage. The input voltage has been changed to 3 V to represent a supply built with two batteries.

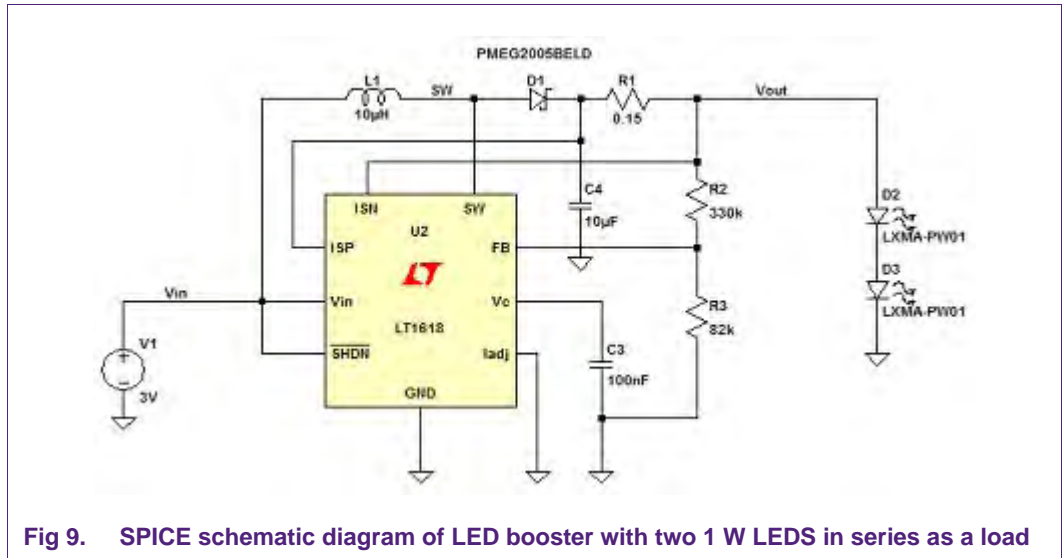

Fig 9. SPICE schematic diagram of LED booster with two 1 W LEDs in series as a load

Figure 10 depicts SPICE simulation for this use case. The output voltage is about 6.32 V. The peak current in the diode reaches about 0.7 A.

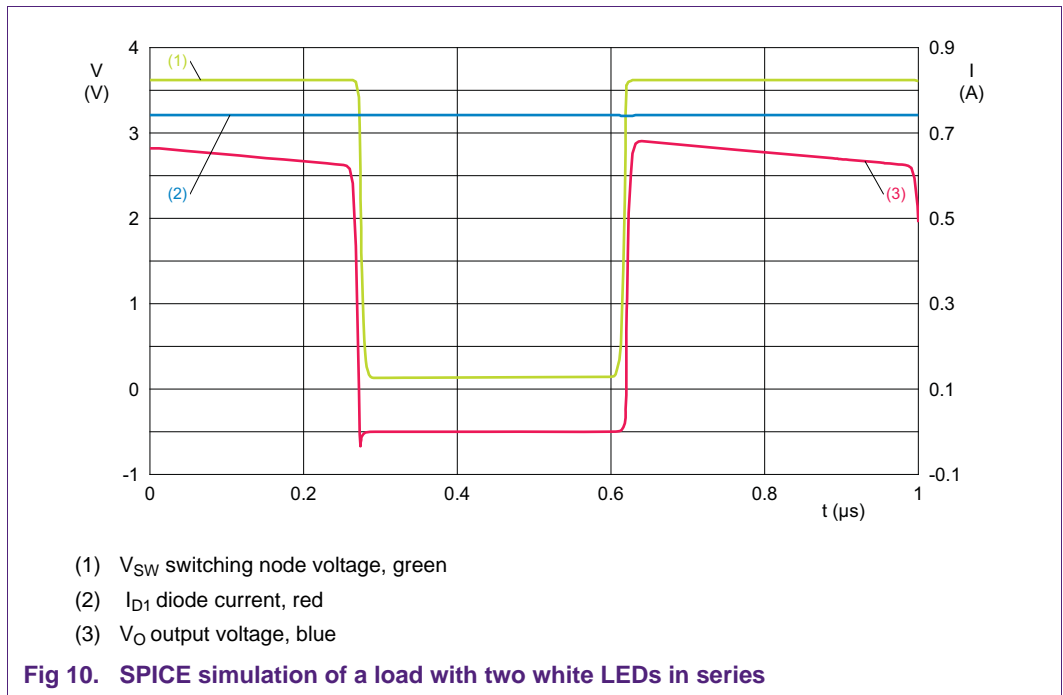
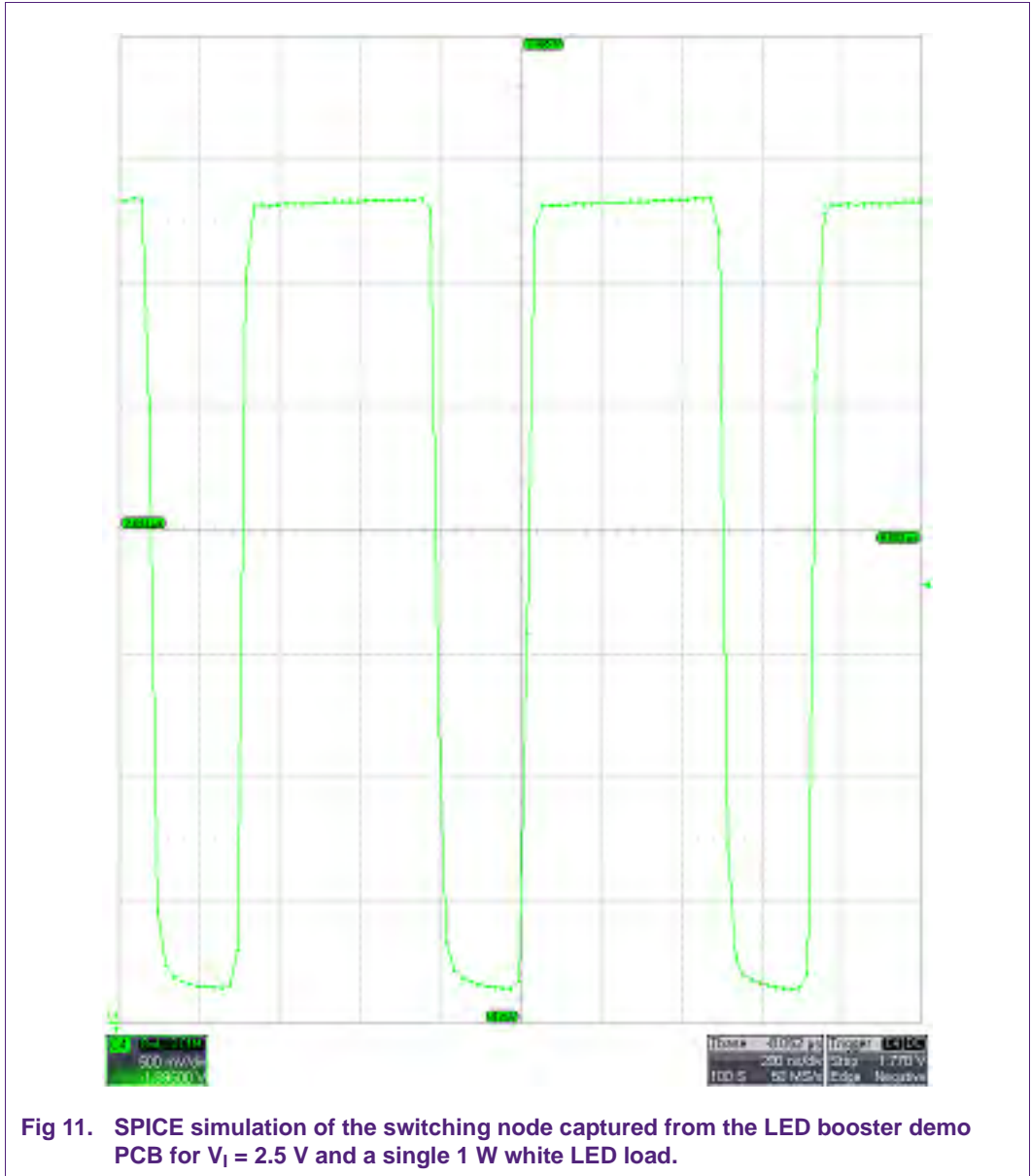

Fig 10. SPICE simulation of a load with two white LEDs in series

Figure 11 shows a scope trace measured at the voltage booster demo PCB. The measurements conditions are: 2.5 V input voltage supply and an output load of a single 1 W white LED. Due to the small voltage boosting factor, the duty cycle is small. This means the on-time for the switch in the controller IC is quite short compared to the cycle time. The switching frequency proves to be about 1.4 MHz as specified for the LT1618.



### 3.2 Thermal performance of the DFN and DSN Schottky diodes

[Table 1](#) shows a comparison of Surface-Mounted Device (SMD) packages for the thermal performance. Very small DSN0603-2 (SOD962) chip scale package, with a length of 0.6 mm, a width and a height of 0.3 mm, can provide a similar  $P_{tot}$  as much bigger standard SMD packages SOD523 or SOD323. 325 mW can be dissipated on a standard footprint at an ambient temperature of 25°C. With 1 cm<sup>2</sup> cathode pad, even 0.525 W can be achieved.

The DFN1006D-2 (SOD882D) plastic package which measures 1 mm × 0.6 mm × 0.37 mm, can dissipate 370 mW on the standard or minimum footprint. With 1 cm<sup>2</sup> cathode pad  $P_{tot}$  of up to 735 mW is reached.

Products in DFN2020 packages can be found in many tablet backlight applications where a bigger power is provided for the LED strings of the LCD display. The 2 mm × 2 mm packages have a very low thermal resistance from junction to solder point of  $R_{th(j-sp)} = 12 \text{ K/W}$ .

The thermal coupling of the crystal to the solder point is very good for leadless packages because of the direct thermal path from the die into the PCB. Thermal resistance from junction to solder point is listed in the first column of [Table 1](#). If a low  $R_{th(j-sp)}$  is provided, the thermal characteristic of the board has a dominant impact on the maximum power dissipation that a component can dissipate. Modern electronic equipment such as smartphones and mobile computing devices use multilayer board technology because the system chips are ball-grid arrays or integrated circuits with a very small pitch of pins. More than two layers are required to get all the connections realized.

**Table 1. Comparison of the package performance for  $R_{th(j-sp)}$ ,  $P_{tot}$  and  $I_{FSM}$**

Package	$R_{th(j-sp)max}$ (K/W)	$P_{tot}$ 1 cm <sup>2</sup> cathode pad, (mW)	$P_{tot}$ standard footprint, (mW)	$I_{FSM}$ 8.3 ms square wave (A)
DSN0603-2 (SOD962)	40	525	325	6.5
DFN1006-2 (SOD882)	50	660	340	3.0
DFN1006D-2 (SOD882D)	25	735	370	6.0
DFN1608D-2 (SOD1608)	20	895	415	5.0
DFN2020-3 (SOT1061)	12	960	500	17.0
SOD523	75	-	310	6.0
SOD323	90	490	320	9.0
SOD323F	55	830	360	9.0

### 3.3 Thermal performance of the demo PCB

The current in the Schottky diode of the DC-to-DC step-up converter is depicted on [Figure 10](#) by curve 2 (red). The curve for the power dissipation looks very similar to the one shown on [Figure 12](#). A linear decrease of the current can be seen for the time the diode conducts in forward direction and while the low-side switch in the controller IC is switched on, a low reverse current leads to a small loss only. The average power dissipation for the use case with a 1 W white LED load and a 2 V input voltage is about 125 mW. The average power of the pulse is  $P_{pulse} = 235 \text{ mW}$ . The duty cycle is 0.53 from the SPICE simulation.  $Z_{th(j-a)}$  for this duty cycle on a standard footprint and a pulse width of about 0.4  $\mu\text{s}$  can be extrapolated to roughly 130 K/W. The temperature increase can be calculated with:

$$\Delta T = T_j - T_{amb} = Z_{th(j-a)} \times P_{pulse} = 31 \text{ K}$$

For an ambient temperature of 25°C,  $T_j$  of the Schottky diode should become 56 °C. This calculation disregards additional heating from other components on the board. The major contribution comes from the controller IC on the PCB LT1618. It has power losses of about 105 mW.

For a more accurate evaluation of the thermal behavior of the demo PCB, the board was simulated with Mentor Graphics Corporation software FloTHERM. Models of the board and the components were defined and the two mounting options with a Schottky diode in packages DSN0603-2 (SOD962) and DFN1006-2 (SOD882) have been calculated. The additional heat dissipation of the controller IC was modeled as well.

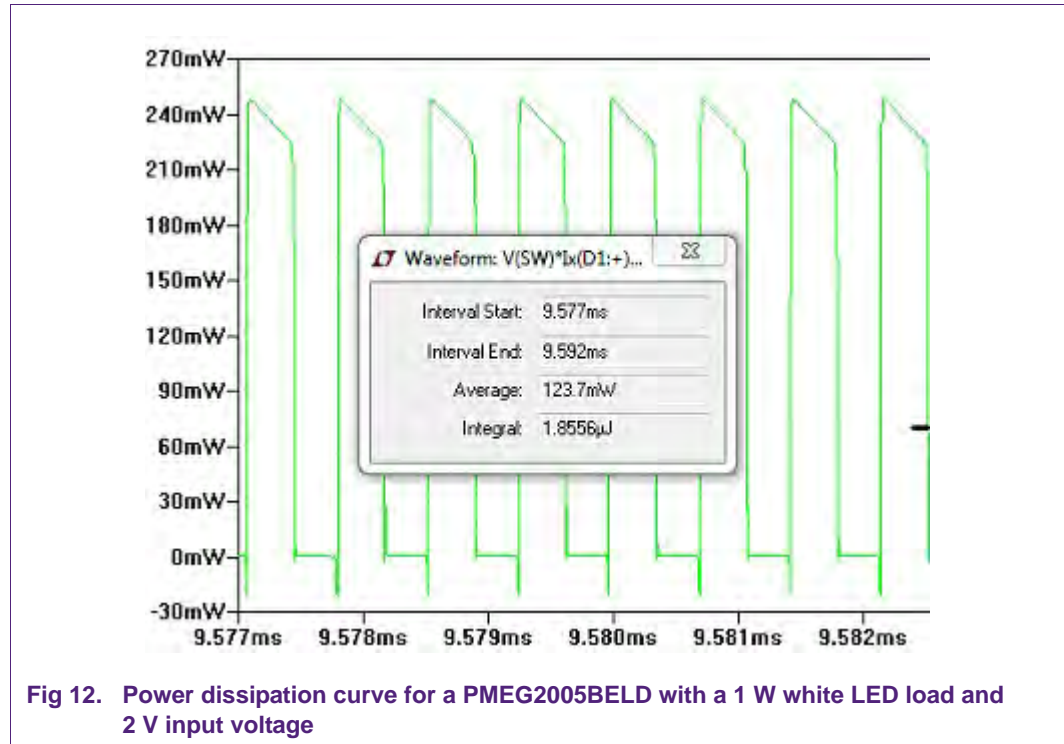

Fig 12. Power dissipation curve for a PMEG2005BELD with a 1 W white LED load and 2 V input voltage

Table 2 shows thermal simulation results, these are the junction temperatures for a power dissipation of 125 mW and the maximum power that can be dissipated if the junction temperature shall not exceed 125 °C and 150 °C. The junction temperature of the Schottky diode is about 10 degree higher than the result of the calculation in which the diode is the only component dissipating heat into the PCB. However on the PCB there are significant power losses generated by the controller IC.

Table 2. FloTHERM results for the DC-to-DC booster demo PCB, junction temperature for  $P_{tot} = 125 \text{ mW}$  and the maximum power dissipation for  $T_j = 125 \text{ °C}$  and  $150 \text{ °C}$  for  $T_{amb} = 25 \text{ °C}$

	DFN1006-2 (SOD882)	DSN0603-2 (SOD962)
$P = 125 \text{ mW}$	$T_j = 65 \text{ °C}$	$T_j = 66 \text{ °C}$
$T_j = 125 \text{ °C}$	$P_{tot} = 405 \text{ mW}$	$P_{tot} = 399 \text{ mW}$
$T_j = 150 \text{ °C}$	$P_{tot} = 520 \text{ mW}$	$P_{tot} = 510 \text{ mW}$



Figure 13 shows the temperature profile of the demo PCB for the area around the Schottky diode. The big block left to the diode is the inductor. The left side shows the thermal result for the PMEG2005AESF (DSN0603-2 package) and the PMEG2005BELD (DFN1006D-2 package). The simulation shows the interesting fact that the hot spot for the chip-scale diode is located at the anode side, whereas the part in the plastic package has its hot spot at the cathode side. This difference should be considered for an optimized thermal design with these package types. Thermal pads work most efficiently if they are placed adjacent to the hotter pad for the chosen package to ensure the best thermal path for the heat from the crystal into the board. For the demo board the big pad of the inductor and the bulky metal block of this component create a good heat sink for the DSN0603-2 (SOT962) scenario. The inductor appears green in the 3D image below on Figure 13. This means that it gets warmer compared to the other assembly option with the DFN1006-2 (SOD882) part. This explains why the temperatures for  $P_{tot}$  of 125 mW are very close for the two scenarios, although the thermal performance of a DFN1006D-2 (SOD882D) package is better compared to DSN0603-2 (SOD962).

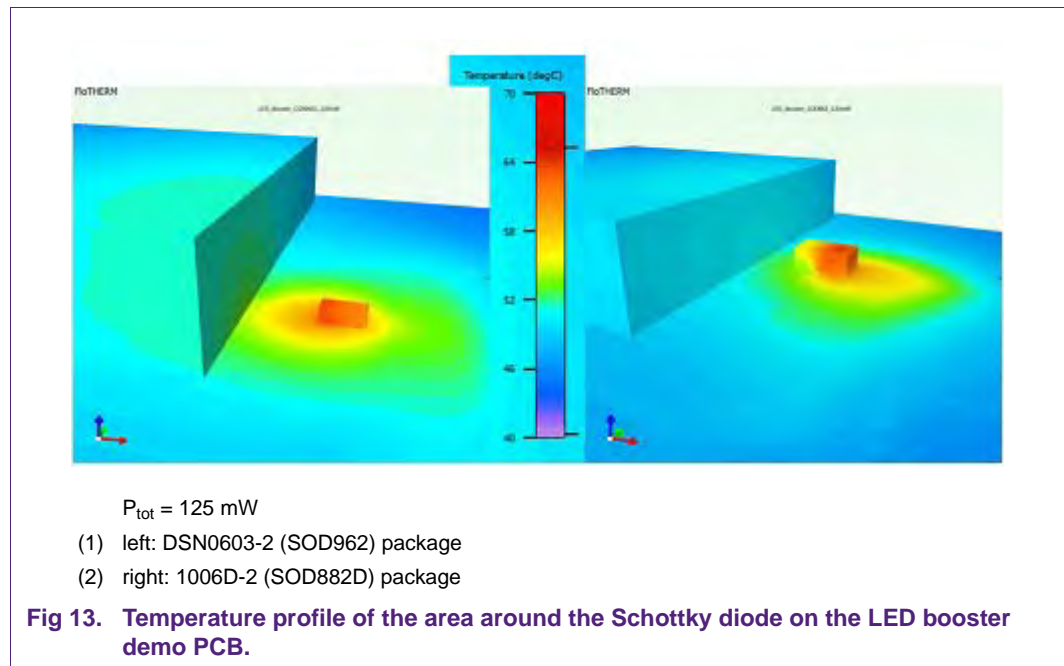

Figure 14 shows a thermal diagram of the whole demo PCB derived from the FloTHERM simulation. The LT1618 controller IC sticks out as a yellow rectangular area.

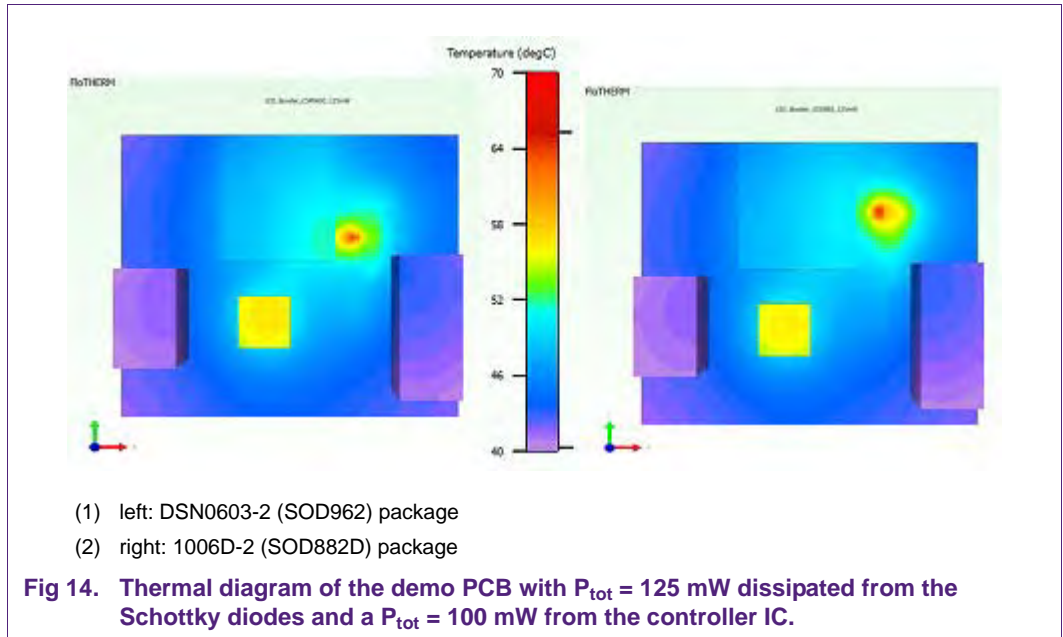
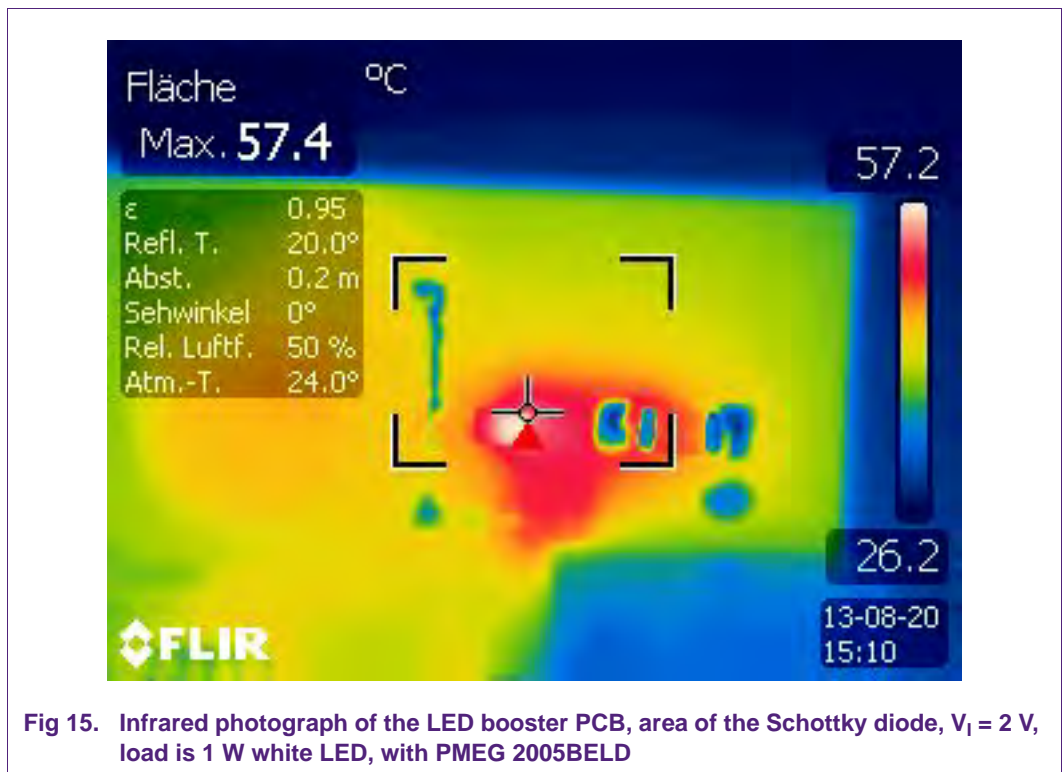

Figure 15 shows an infrared picture taken from an LED booster demo PCB run with an input voltage of 2 V. As output load a 1 W white LED is connected. In this case the temperature of the PMEG2005BELD reaches 57.4 °C. Because  $T_j$  is about 5 to 10 degree warmer than the case, this fits quite well to the simulation results of the FloTHERM tool.



### 3.4 NXP Schottky portfolio in DFN and DSN packages

Table 3 below shows extensive portfolio of NXP Semiconductors Schottky diodes in DFN1006 packages. The maximum reverse voltage ranges from 20 V to 60 V. The maximum forward current rating current has a range from 200 mA up to 1 A. For most of the products two different package heights can be supported. The typical dimensions of DFN1006-2 package are 1 mm × 0.6 mm × 0.48 mm. The DFN1006D-2 (SOD882D) package has a typical height of 0.37 mm only, the length and width is identical to the standard DFN1006-2 (SOD882) package. The Schottky diodes with a type name ending with “ELD” have the package with the reduced height.

PMEG2005BELD and PMEG2010BELD have a benchmarking low forward voltage for this 1 mm × 0.6 mm package type.  $V_{Fmax}$  for a forward current of 0.5 A is 0.44 V only.

**Table 3. NXP Semiconductors Schottky diodes portfolio in DFN1006-2 (SOD882) and DFN1006D-2 (SOD882D)**

Schottky diode type	$V_{Rmax}$ (V)	$I_{Fmax}$ (A)	$I_{Rmax}$ @ $V_{Rmax}$ (mA)	$V_{Fmax}$ @ $V_{Rmax}$ (V)
PMEG3002AEL	30	0.2	0.05	0.48
PMEG3002AELD	30	0.2	0.05	0.48
PMEG4002EL	40	0.2	0.01	0.6
PMEG4002ELD	40	0.2	0.01	0.6
PMEG2005BELD	20	0.5	0.2	0.39
PMEG2005AEL	20	0.5	1.5	0.44
PMEG2005AELD	20	0.5	1.5	0.44
PMEG2005EL	20	0.5	0.03	0.5
PMEG2005ELD	20	0.5	0.03	0.5
PMEF3005EL	30	0.5	0.5	0.5
PMEG3005ELD	30	0.5	0.5	0.5
PMEG2010BELD	20	1.0	0.2	0.49
PMEG6002ELD	60	0.2	0.1	0.6

Table 4 lists NXP Semiconductors Schottky diodes in a Wafer-Level Chip-Scale Package (WLCSP) technology. The DSN0603-2 (SOD962) package has the dimensions of 0.6 mm × 0.3 mm × 0.3 mm only. This package is introduced for ESD diodes to a big extend in the mobile communication market already. It allows a further miniaturization of designs and a further step to achieve a higher power density in medium power applications. Due to the fact that the crystal size is identical with the dimensions of the package, a very good electrical performance can be achieved.

NXP Semiconductors offers two types of 20 V Schottky diodes in DSN0603-2 (SOD962). The PMEG2002AESF is optimized for a low forward voltage drop.  $V_F$  for  $I_F = 200$  mA or  $I_F = 500$  ma is typically 420 mV only. The PMEG2002ESF is optimized for a low reverse current. Maximum  $I_R$  at  $T_j = 25$  °C is 3.5  $\mu$ A only. PMEG2005AESF provides maximum  $V_F$  of 0.6 V for  $I_F = 0.5$  A. Schottky diodes for a maximum reverse voltage of 30 V and 40 V are listed as well.

These new WLCSP Schottky diodes enable a further step of miniaturization in mobile communication devices.

Table 4. NXP Schottky diodes portfolio in DSN0603-2 (SOD962)

Schottky diode type	V <sub>R</sub> max (V)	I <sub>F</sub> max (A)	I <sub>R</sub> typ @V <sub>R</sub> max (μA)	V <sub>F</sub> max @V <sub>R</sub> max (V)
PMEG2002AESF	20	0.2	45	0.42
PMEG2002ESF	20	0.2	4	0.49
PMEG2005AESF	20	0.5	45	0.55
PMEG2005ESF	20	0.5	4	0.6
PMEG3002AESF	30	0.2	100	0.48
PMEG3002ESF	30	0.2	10	0.55
PMEG3005AESF	30	0.5	100	0.63
PMEG4002ESF	40	0.2	10	0.6
PMEG4002AESF	40	0.2	95	0.53

The package type DFN1608D-2 (SOD1608) has become very popular in backlight application for mobile devices such as smartphones. The dimensions of this package are 1.6 mm × 0.8 mm × 0.37 mm. NXP Semiconductors offers products with 20 V and 40 V maximum reverse voltage as depicted on [Table 5](#). The 20 V types are low V<sub>F</sub> versions, whereas 40 V products are optimized for a low leakage current.

Table 5. NXP Schottky diodes portfolio in DFN1608D-2 (SOD1608)

Schottky diode type	V <sub>R</sub> max (V)	I <sub>F</sub> max (A)	I <sub>R</sub> max @V <sub>R</sub> max (mA)	V <sub>F</sub> max @V <sub>R</sub> max (V)
PMEG2015EPK	20	1.5	0.9	0.42
PMEG4015EPK	40	1.5	0.03	0.61
PMEG2020EPK	20	2.0	0.9	0.45
PMEG4020EPK	40	2.0	0.03	0.66

[Table 6](#) shows NXP Semiconductors Schottky diode products in the DFN2020-3 (SOT1061) package. It has the dimensions of 2 mm × 2 mm × 0.62 mm. This package type can often be found in backlight applications for tablet PCs. The reverse voltage ranges from 20 V up to 60 V. This allows to find a suitable diode for the applied LED string length. The maximum forward current is 2 A for the single diode types and 1 A or 2 A for the dual diode types.

Table 6. NXP Schottky diodes portfolio in DFN2020-3 (SOT1061)

Schottky diode type	$V_R$ max (V)	$I_F$ max (A)	$I_R$ max @ $V_R$ max (mA)	$V_F$ max @ $V_R$ max (V)
single diode				
PMEG2020EPA	20	2.0	1.9	0.42
PMEG3020EPA	30	2.0	2.5	0.47
PMEG4020EPA	40	2.0	0.1	0.535
PMEG6020EPA	60	2.0	0.25	0.575
double diode, common cathode				
PMEG4010CPA	40	1.0	0.05	0.5
PMEG6010CPA	60	1.0	0.06	0.54
PMEG2020CPA	20	2.0	1.0	0.42
PMEG3020CPA	30	2.0	2.0	0.44

## 4. Summary

NXP Semiconductor Schottky diodes in leadless packages such as DFN1006-2, DFN1608-2 and DFN2020-3 and the chip-scale packages DSN0603-2 and DFN1006-2 allow more compact designs because of their good electrical and thermal performance. This enables to make designs with an increased power density where more power can be handled on a small mounting area. In modern electronic designs such as ultrabooks, tablet PCs and smartphones, space constraints are getting more and more tough. Due to the fact that all these applications are battery-driven, energy efficiency is an important selection criterion as well. Low forward voltages of the Schottky diodes help reducing losses.

The DC-to-DC step-up converter demo PCB described in this document proves that NXP semiconductors small Schottky diodes can replace bigger packages very well without compromising on performance, energy efficiency and reliability.

## 5. Appendix

In this appendix further information is given about the LED voltage booster demo PCB. [Figure 16](#) shows the place plan with the component values. [Figure 17](#) depicts the top layer of the board. The bottom layer is a solid copper ground plane.

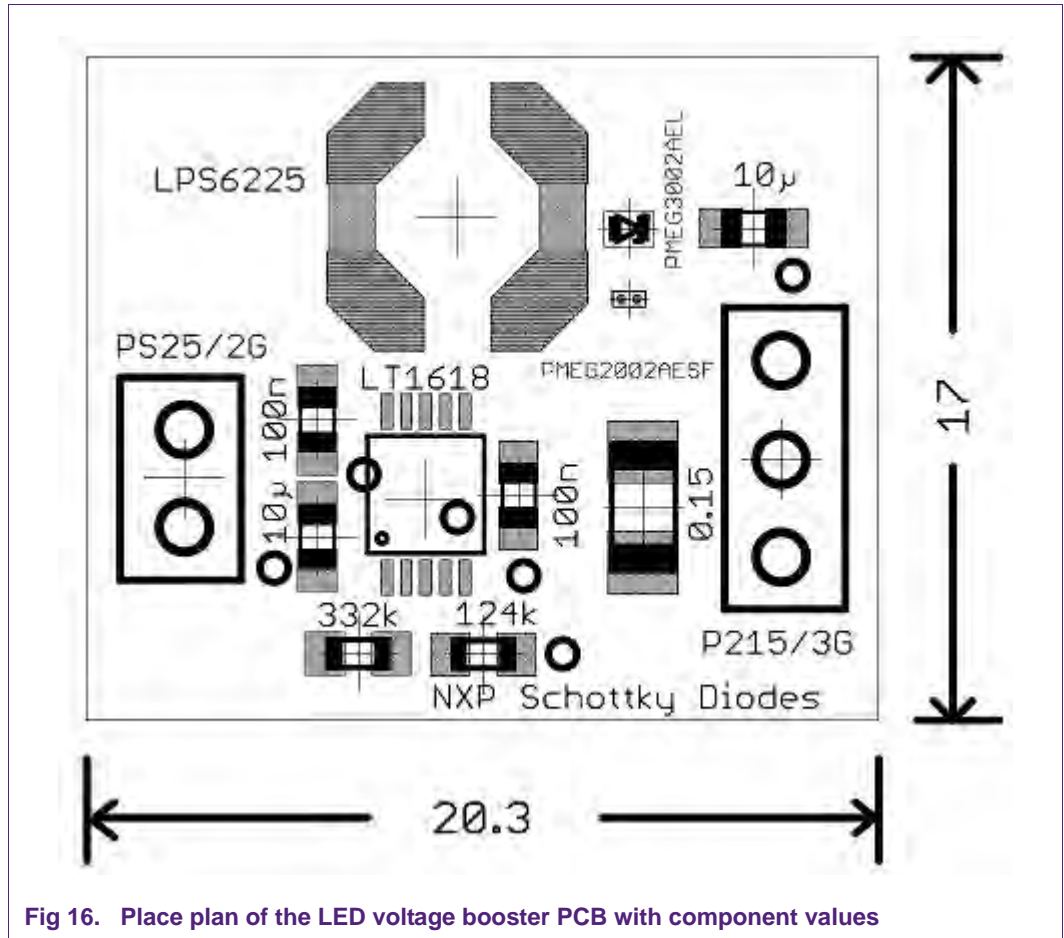
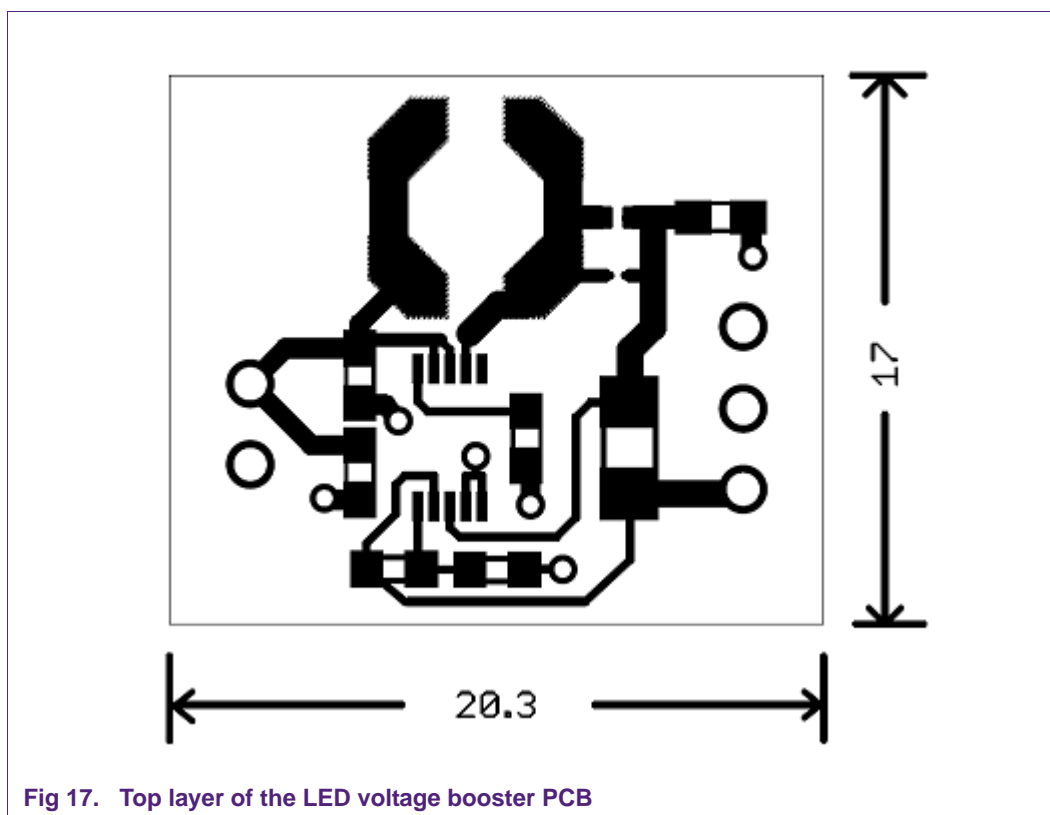

Fig 16. Place plan of the LED voltage booster PCB with component values



## 6. References

- [1] Application Note AN11119 Medium power small-signal MOSFETs in DC-to-DC conversion.



## 7. Legal information

### 7.1 Definitions

**Draft** — The document is a draft version only. The content is still under internal review and subject to formal approval, which may result in modifications or additions. NXP Semiconductors does not give any representations or warranties as to the accuracy or completeness of information included herein and shall have no liability for the consequences of use of such information.

### 7.2 Disclaimers

**Limited warranty and liability** — Information in this document is believed to be accurate and reliable. However, NXP Semiconductors does not give any representations or warranties, expressed or implied, as to the accuracy or completeness of such information and shall have no liability for the consequences of use of such information. NXP Semiconductors takes no responsibility for the content in this document if provided by an information source outside of NXP Semiconductors.

In no event shall NXP Semiconductors be liable for any indirect, incidental, punitive, special or consequential damages (including - without limitation - lost profits, lost savings, business interruption, costs related to the removal or replacement of any products or rework charges) whether or not such damages are based on tort (including negligence), warranty, breach of contract or any other legal theory.

Notwithstanding any damages that customer might incur for any reason whatsoever, NXP Semiconductors' aggregate and cumulative liability towards customer for the products described herein shall be limited in accordance with the *Terms and conditions of commercial sale* of NXP Semiconductors.

**Right to make changes** — NXP Semiconductors reserves the right to make changes to information published in this document, including without limitation specifications and product descriptions, at any time and without notice. This document supersedes and replaces all information supplied prior to the publication hereof.

**Suitability for use** — NXP Semiconductors products are not designed, authorized or warranted to be suitable for use in life support, life-critical or safety-critical systems or equipment, nor in applications where failure or malfunction of an NXP Semiconductors product can reasonably be expected to result in personal injury, death or severe property or environmental damage. NXP Semiconductors and its suppliers accept no liability for inclusion and/or use of NXP Semiconductors products in such equipment or applications and therefore such inclusion and/or use is at the customer's own risk.

**Applications** — Applications that are described herein for any of these products are for illustrative purposes only. NXP Semiconductors makes no representation or warranty that such applications will be suitable for the specified use without further testing or modification.

Customers are responsible for the design and operation of their applications and products using NXP Semiconductors products, and NXP Semiconductors accepts no liability for any assistance with applications or customer product design. It is customer's sole responsibility to determine whether the NXP Semiconductors product is suitable and fit for the customer's applications and products planned, as well as for the planned application and use of customer's third party customer(s). Customers should provide appropriate design and operating safeguards to minimize the risks associated with their applications and products.

NXP Semiconductors does not accept any liability related to any default, damage, costs or problem which is based on any weakness or default in the customer's applications or products, or the application or use by customer's third party customer(s). Customer is responsible for doing all necessary testing for the customer's applications and products using NXP Semiconductors products in order to avoid a default of the applications and the products or of the application or use by customer's third party customer(s). NXP does not accept any liability in this respect.

**Export control** — This document as well as the item(s) described herein may be subject to export control regulations. Export might require a prior authorization from competent authorities.

**Evaluation products** — This product is provided on an "as is" and "with all faults" basis for evaluation purposes only. NXP Semiconductors, its affiliates and their suppliers expressly disclaim all warranties, whether express, implied or statutory, including but not limited to the implied warranties of non-infringement, merchantability and fitness for a particular purpose. The entire risk as to the quality, or arising out of the use or performance, of this product remains with customer.

In no event shall NXP Semiconductors, its affiliates or their suppliers be liable to customer for any special, indirect, consequential, punitive or incidental damages (including without limitation damages for loss of business, business interruption, loss of use, loss of data or information, and the like) arising out of the use of or inability to use the product, whether or not based on tort (including negligence), strict liability, breach of contract, breach of warranty or any other theory, even if advised of the possibility of such damages.

Notwithstanding any damages that customer might incur for any reason whatsoever (including without limitation, all damages referenced above and all direct or general damages), the entire liability of NXP Semiconductors, its affiliates and their suppliers and customer's exclusive remedy for all of the foregoing shall be limited to actual damages incurred by customer based on reasonable reliance up to the greater of the amount actually paid by customer for the product or five dollars (US\$5.00). The foregoing limitations, exclusions and disclaimers shall apply to the maximum extent permitted by applicable law, even if any remedy fails of its essential purpose.

### 7.3 Trademarks

Notice: All referenced brands, product names, service names and trademarks are the property of their respective owners.



## 8. Contents

---

<b>1</b>	<b>Introduction</b> .....	<b>3</b>
<b>2</b>	<b>Methods of DC-to-DC voltage up conversion</b> .	<b>4</b>
2.1	Voltage up conversion based on charge pumps	4
2.2	Inductor-based voltage up converter .....	6
<b>3</b>	<b>Demo PCB DC-to-DC step-up converter using very small Schottky diodes</b> .....	<b>10</b>
3.1	Hardware of the DC-to-DC step-up converter on demo PCB .....	10
3.2	Thermal performance of the DFN and DSN Schottky diodes .....	14
3.3	Thermal performance of the demo PCB. ....	15
3.4	NXP Schottky portfolio in DFN and DSN packages .....	19
<b>4</b>	<b>Summary</b> .....	<b>21</b>
<b>5</b>	<b>Appendix</b> .....	<b>21</b>
<b>6</b>	<b>References</b> .....	<b>23</b>
<b>7</b>	<b>Legal information</b> .....	<b>24</b>
7.1	Definitions .....	24
7.2	Disclaimers .....	24
7.3	Trademarks .....	24
<b>8</b>	<b>Contents</b> .....	<b>25</b>

---

Please be aware that important notices concerning this document and the product(s) described herein, have been included in section 'Legal information'.

---

© NXP B.V. 2014.

All rights reserved.

For more information, please visit: <http://www.nxp.com>

For sales office addresses, please send an email to: [salesaddresses@nxp.com](mailto:salesaddresses@nxp.com)

Date of release: 22 April 2014

Document identifier: AN11470

## X-ON Electronics

Largest Supplier of Electrical and Electronic Components

*Click to view similar products for [nxp](#) manufacturer:*

Other Similar products are found below :

[MC13211R2](#) [PCA9518PW,112](#) [LFSTBEB865X](#) [MC33399PEFR2](#) [PCA9551PW,112](#) [MC34825EPR2](#) [CBTW28DD14AETJ](#) [PCF8583P](#)  
[MC68340AB16E](#) [MC8640DTVJ1250HE](#) [EVBCRTOUCH](#) [MC9S08PT16AVLC](#) [MC9S08PT8AVTG](#) [MC9S08SH32CTL](#) [MCF54415CMJ250](#)  
[MCIMX6Q-SDB](#) [MCIMX6SX-SDB](#) [74ALVC125BQ,115](#) [74HC4050N](#) [74HC4514N](#) [MK21FN1M0AVLQ12](#) [MKV30F128VFM10](#) [FRDM-K66F](#) [FRDM-KW40Z](#) [FRDM-MC-LVBLDC](#) [PESD18VF1BSFYL](#) [PMF63UNEX](#) [PSMN4R0-60YS,115](#) [HEF4028BPN](#) [RAPPID-567XFSW](#)  
[MPC565MVR56](#) [MPC574XG-176DS](#) [MPC860PCVR66D4](#) [BT137-600E](#) [BT139X-600.127](#) [BUK7628-100A118](#) [BUK765R0-100E.118](#)  
[BZT52H-B9V1.115](#) [BZV85-C3V9.113](#) [BZX79-C47.113](#) [P5020NSE7VNB](#) [S12ZVML12EVBLIN](#) [SCC2692AC1N40](#) [LPC1785FBD208K](#)  
[LPC2124FBD64/01](#) [LS1020ASN7KQB](#) [LS1020AXN7HNB](#) [LS1020AXN7KQB](#) [LS1043ASE7PQA](#) [T1023RDB-PC](#)