

UM11806

PTN3222CUK-EVB demo board user manual

Rev. 1 — 25 May 2022

User manual

Document information

Information	Content
Keywords	PTN3222CUK, eUSB2, eUSB2 repeater, eUSB2 redrive, PTN3222CUK demo board
Abstract	This user manual describes the PTN3222CUK-EVB demo board in detail, along with the setup instruction to allow the user to quickly set up the board for validation.



Revision history

Rev	Date	Description
v.1	20220525	initial version

IMPORTANT NOTICE**For engineering development or evaluation purposes only**

NXP provides the product under the following conditions:

This evaluation kit is for use of **ENGINEERING DEVELOPMENT OR EVALUATION PURPOSES ONLY**. It is provided as a sample IC pre-soldered to a printed-circuit board to make it easier to access inputs, outputs and supply terminals. This evaluation board may be used with any development system or other source of I/O signals by connecting it to the host MCU computer board via off-the-shelf cables. This evaluation board is not a Reference Design and is not intended to represent a final design recommendation for any particular application. Final device in an application heavily depends on proper printed-circuit board layout and heat sinking design as well as attention to supply filtering, transient suppression, and I/O signal quality.

The product provided may not be complete in terms of required design, marketing, and or manufacturing related protective considerations, including product safety measures typically found in the end device incorporating the product. Due to the open construction of the product, it is the responsibility of the user to take all appropriate precautions for electric discharge. In order to minimize risks associated with the customers' applications, adequate design and operating safeguards must be provided by the customer to minimize inherent or procedural hazards. For any safety concerns, contact NXP sales and technical support services.

1 Introduction

PTN3222CUK is a one-port eUSB2 to USB2 redriver IC that performs translation between eUSB2 and USB2 signaling schemes. It is meant to be used in systems that have an eUSB2 interface on one side and a USB2 interface on the other side. It supports host-role only, device-role only or dual-role repeater function.

PTN3222CUK implements repeater mode (eUSB2 to USB2 redriver) and it supports Link Power management features. PTN3222CUK is targeted to be USB2 compliant and eUSB2 conformant. It supports all three speeds/data rates: low speed (1.5 Mbps), full speed (12 Mbps) and high speed (480 Mbps).

This document is intended to help a user quickly set up, configure and operate the PTN3222CUK-EVB evaluation board in the user's hardware platform. The user manual is applicable to both evaluation boards.

2 Getting ready

Working with the PTN3222CUK-EVB evaluation board requires the kit contents, additional hardware, and a Windows PC workstation with installed software.

2.1 Kit contents

The PTN3222CUK-EVB kit includes:

- Assembled and tested evaluation board in an antistatic bag
- Quick Start Guide

3 Finding kit resources and information on the NXP web site

NXP Semiconductors provides online resources for this evaluation board and its supported device(s) on <https://www.nxp.com/>.

The information page for the PTN3222CUK-EVB evaluation board is at <http://www.nxp.com/PTN3222CUK-EVB>. The information page provides overview information, documentation, software and tools, parametrics, ordering information and a Getting Started tab. The Getting Started tab provides quick-reference information applicable to using the PTN3222CUK-EVB evaluation board, including the downloadable assets referenced in this document.

4 Getting to know the hardware

4.1 Kit featured components

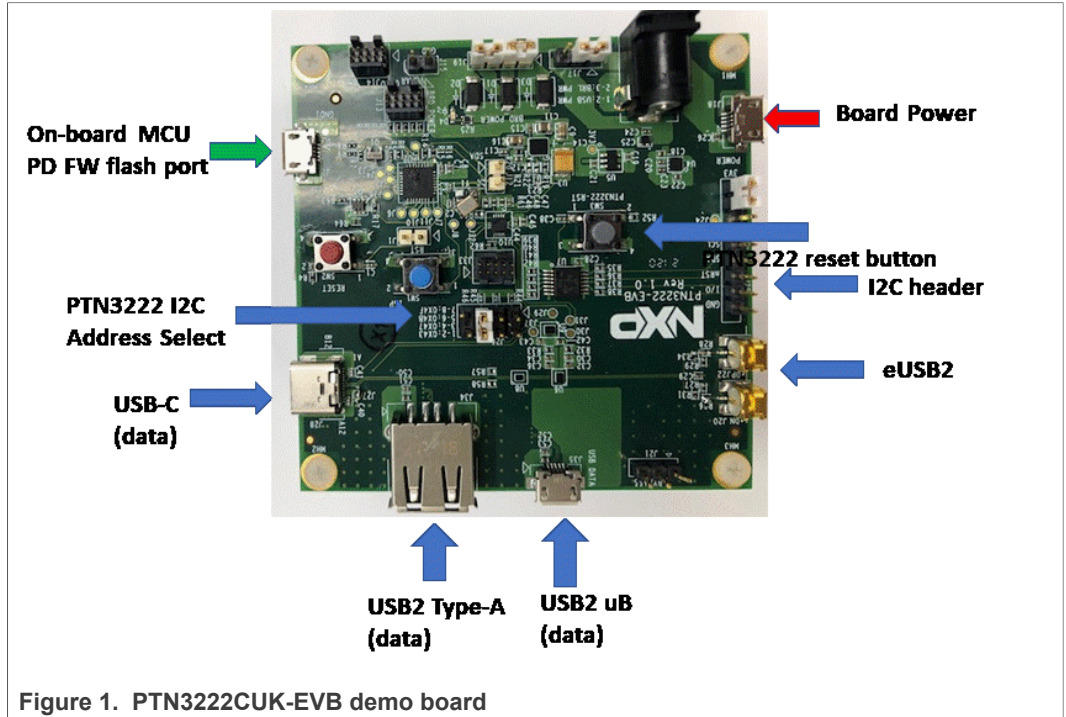

4.2 Block diagram

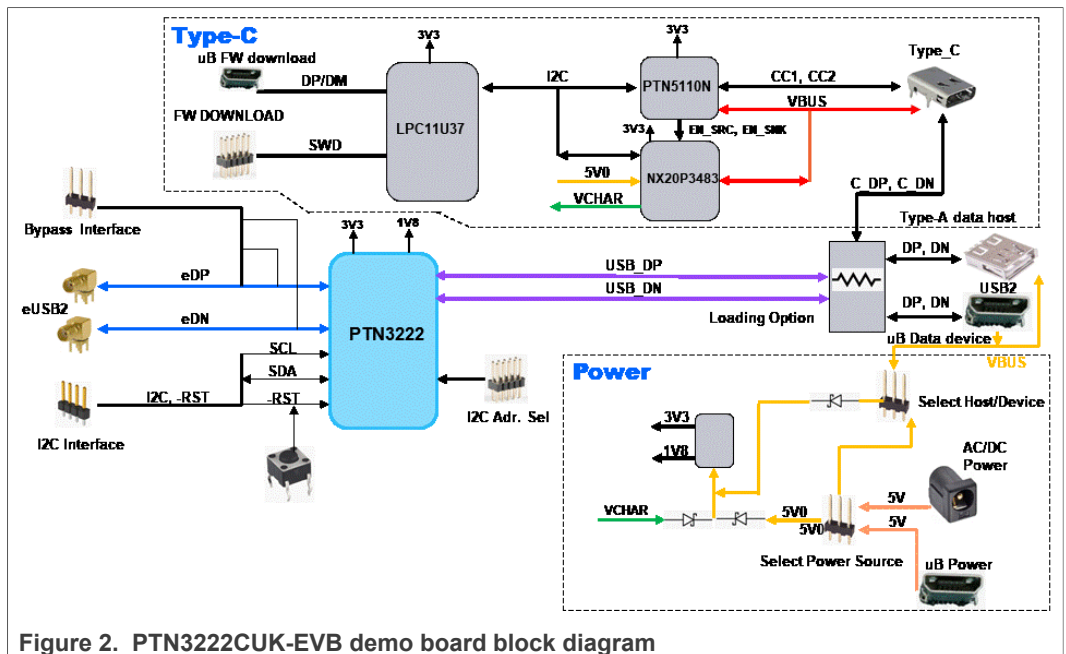

4.2.1 eUSB2 to USB2 connector routing

USB2 differential signals can be hardwired via a pair of 0 ohm resistors to type C connector, standard A connector or uB connector. To prevent PCB trace stubs from

4.4 I²C host interface and 3V3 level shifter

J25 is the host I²C interface that allows the host to control PTN3222CUK via I²C bus. There is an onboard level shifter to shift 3V3 I²C bus on the host side to 1V8 I²C comparable level on the PTN3222CUK side. If the I²C voltage level on the host side is from 1V2 to 1V8, then the onboard level shifter can be removed and bypassed with R48-R51.

PTN3222CUK can be hardwired to one of four I²C target addresses: 0x43, 0x47, 0x4B and 0x4F, and J26 is used for PTN3222CUK I²C target address selection. If the I²C target address is selected after PTN3222CUK has been powered up, PTN3222CUK must be power recycled or reset for the new I²C address to take effect.

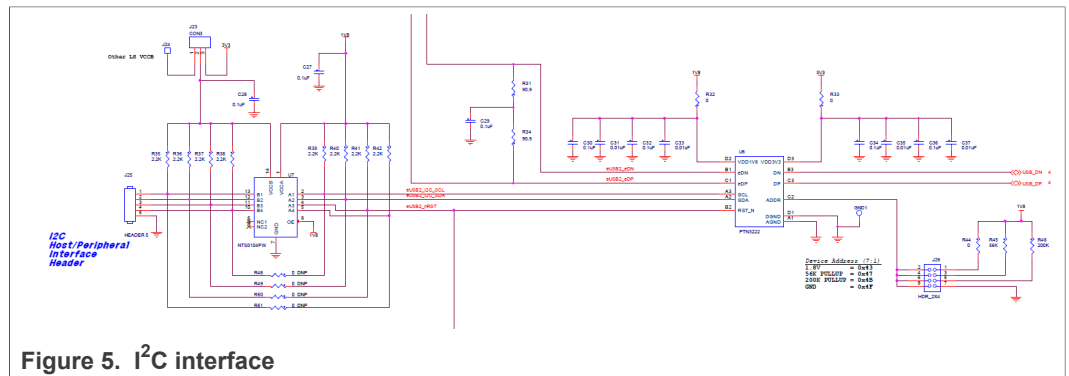

Figure 5. I²C interface

4.5 Schematic, board layout and bill of materials

The schematic, board layout and bill of materials for the PTN3222CUK-EVB evaluation board are available at <http://www.nxp.com/PTN3222CUK>.

5 Board Layout

The layout of this board follows the general layout guidelines in AN13462^[1]. This is a separate application note and should be used as reference and guidelines to layout PCB traces, design PCB trace impedance, placing of decoupling capacitors, etc.

6 Abbreviations

Acronym	Description
IC	integrated circuit
MCU	microcontroller unit
PCB	printed-circuit board
SMP	switch mode power supply
USB	universal serial bus

7 References

[1] **PTN3222 layout guidelines** —PTN3222 is a 1-port eUSB2 to USB2 redriver IC that performs translation between eUSB2 and USB2 signaling schemes. <https://www.nxp.com/docs/en/application-note/AN13462.pdf>

8 Legal information

8.1 Definitions

Draft — A draft status on a document indicates that the content is still under internal review and subject to formal approval, which may result in modifications or additions. NXP Semiconductors does not give any representations or warranties as to the accuracy or completeness of information included in a draft version of a document and shall have no liability for the consequences of use of such information.

8.2 Disclaimers

Limited warranty and liability — Information in this document is believed to be accurate and reliable. However, NXP Semiconductors does not give any representations or warranties, expressed or implied, as to the accuracy or completeness of such information and shall have no liability for the consequences of use of such information. NXP Semiconductors takes no responsibility for the content in this document if provided by an information source outside of NXP Semiconductors.

In no event shall NXP Semiconductors be liable for any indirect, incidental, punitive, special or consequential damages (including - without limitation - lost profits, lost savings, business interruption, costs related to the removal or replacement of any products or rework charges) whether or not such damages are based on tort (including negligence), warranty, breach of contract or any other legal theory.

Notwithstanding any damages that customer might incur for any reason whatsoever, NXP Semiconductors' aggregate and cumulative liability towards customer for the products described herein shall be limited in accordance with the Terms and conditions of commercial sale of NXP Semiconductors.

Right to make changes — NXP Semiconductors reserves the right to make changes to information published in this document, including without limitation specifications and product descriptions, at any time and without notice. This document supersedes and replaces all information supplied prior to the publication hereof.

Suitability for use — NXP Semiconductors products are not designed, authorized or warranted to be suitable for use in life support, life-critical or safety-critical systems or equipment, nor in applications where failure or malfunction of an NXP Semiconductors product can reasonably be expected to result in personal injury, death or severe property or environmental damage. NXP Semiconductors and its suppliers accept no liability for inclusion and/or use of NXP Semiconductors products in such equipment or applications and therefore such inclusion and/or use is at the customer's own risk.

Applications — Applications that are described herein for any of these products are for illustrative purposes only. NXP Semiconductors makes no representation or warranty that such applications will be suitable for the specified use without further testing or modification.

Customers are responsible for the design and operation of their applications and products using NXP Semiconductors products, and NXP Semiconductors accepts no liability for any assistance with applications or customer product design. It is customer's sole responsibility to determine whether the NXP Semiconductors product is suitable and fit for the customer's applications and products planned, as well as for the planned application and use of customer's third party customer(s). Customers should provide appropriate design and operating safeguards to minimize the risks associated with their applications and products.

NXP Semiconductors does not accept any liability related to any default, damage, costs or problem which is based on any weakness or default in the customer's applications or products, or the application or use by customer's third party customer(s). Customer is responsible for doing all necessary testing for the customer's applications and products using NXP Semiconductors products in order to avoid a default of the applications and the products or of the application or use by customer's third party customer(s). NXP does not accept any liability in this respect.

Terms and conditions of commercial sale — NXP Semiconductors products are sold subject to the general terms and conditions of commercial sale, as published at <http://www.nxp.com/profile/terms>, unless otherwise agreed in a valid written individual agreement. In case an individual agreement is concluded only the terms and conditions of the respective agreement shall apply. NXP Semiconductors hereby expressly objects to applying the customer's general terms and conditions with regard to the purchase of NXP Semiconductors products by customer.

Export control — This document as well as the item(s) described herein may be subject to export control regulations. Export might require a prior authorization from competent authorities.

Suitability for use in non-automotive qualified products — Unless this data sheet expressly states that this specific NXP Semiconductors product is automotive qualified, the product is not suitable for automotive use. It is neither qualified nor tested in accordance with automotive testing or application requirements. NXP Semiconductors accepts no liability for inclusion and/or use of non-automotive qualified products in automotive equipment or applications.

In the event that customer uses the product for design-in and use in automotive applications to automotive specifications and standards, customer (a) shall use the product without NXP Semiconductors' warranty of the product for such automotive applications, use and specifications, and (b) whenever customer uses the product for automotive applications beyond NXP Semiconductors' specifications such use shall be solely at customer's own risk, and (c) customer fully indemnifies NXP Semiconductors for any liability, damages or failed product claims resulting from customer design and use of the product for automotive applications beyond NXP Semiconductors' standard warranty and NXP Semiconductors' product specifications.

Translations — A non-English (translated) version of a document, including the legal information in that document, is for reference only. The English version shall prevail in case of any discrepancy between the translated and English versions.

Security — Customer understands that all NXP products may be subject to unidentified vulnerabilities or may support established security standards or specifications with known limitations. Customer is responsible for the design and operation of its applications and products throughout their lifecycles to reduce the effect of these vulnerabilities on customer's applications and products. Customer's responsibility also extends to other open and/or proprietary technologies supported by NXP products for use in customer's applications. NXP accepts no liability for any vulnerability. Customer should regularly check security updates from NXP and follow up appropriately. Customer shall select products with security features that best meet rules, regulations, and standards of the intended application and make the ultimate design decisions regarding its products and is solely responsible for compliance with all legal, regulatory, and security related requirements concerning its products, regardless of any information or support that may be provided by NXP.

NXP has a Product Security Incident Response Team (PSIRT) (reachable at PSIRT@nxp.com) that manages the investigation, reporting, and solution release to security vulnerabilities of NXP products.

8.3 Trademarks

Notice: All referenced brands, product names, service names, and trademarks are the property of their respective owners.

NXP — wordmark and logo are trademarks of NXP B.V.

Figures

Fig. 1.	PTN3222CUK-EVB demo board	5	Fig. 4.	PTN3222CUK-EVB demo board power selection	6
Fig. 2.	PTN3222CUK-EVB demo board block diagram	5	Fig. 5.	I2C interface	7
Fig. 3.	USB2 connector selection	6			

Contents

1	Introduction	4
2	Getting ready	4
2.1	Kit contents	4
3	Finding kit resources and information on the NXP web site	4
4	Getting to know the hardware	4
4.1	Kit featured components	5
4.2	Block diagram	5
4.2.1	eUSB2 to USB2 connector routing	5
4.3	Board power	6
4.4	I2C host interface and 3V3 level shifter	7
4.5	Schematic, board layout and bill of materials	7
5	Board Layout	7
6	Abbreviations	7
7	References	7
8	Legal information	8

Please be aware that important notices concerning this document and the product(s) described herein, have been included in section 'Legal information'.

© NXP B.V. 2022.

All rights reserved.

For more information, please visit: <http://www.nxp.com>

For sales office addresses, please send an email to: salesaddresses@nxp.com

Date of release: 25 May 2022
Document identifier: UM11806

X-ON Electronics

Largest Supplier of Electrical and Electronic Components

Click to view similar products for [Interface Development Tools](#) category:

Click to view products by [NXP](#) manufacturer:

Other Similar products are found below :

[CHA2066-99F](#) [TW-DONGLE-USB](#) [XR21B1424IV64-0A-EVB](#) [STR-FUSB3307MPX-PPS-GEVK](#) [MAX7313EVKIT+](#) [P0551](#)
[ZSC31010KITV2P1](#) [TDP1204EVM](#) [5346](#) [SI32185ACB10SL1KIT](#) [Si32185ACB10SL0EVB](#) [RAA2S4252EXT](#) [4901](#) [DFR0979](#) [LIME2-](#)
[SHIELD](#) [SC18IS604-EVB](#) [MIKROE-5276](#) [CP2104-MINIEK](#) [103030295](#) [LVDS-18B-EVK](#) [MIKROE-2335](#) [KIT_MINIWIGGLER_3_USB](#)
[KITXMC4XCOMETH001TOBO1](#) [XR20M1170G16-0A-EB](#) [XR20M1170G16-0B-EB](#) [XR20M1170G24-0B-EB](#) [XR20M1172G28-0B-EB](#)
[73931-3022](#) [SI871XSOIC8-KIT](#) [1764](#) [1833](#) [TCA8418E-EVM](#) [1862](#) [EVAL-ADM2486EBZ](#) [EVAL-ADM2487EEB3Z](#)
[EVALISO1I811TTOBO1](#) [EVB-USB82514](#) [ATAB663254A-V1.2](#) [AS8650](#) [DB V10](#) [EVAL-ADM2587EEBZ](#) [EVAL-ADM3251EEB1Z](#)
[EVAL-ADUSB2EBUZ](#) [EVAL-ADUSB2EBZ](#) [EVAL-CN0160-EB1Z](#) [EVAL-CN0185-EB1Z](#) [EVB80104-A1](#) [2264](#) [MCP23X17EV](#) [PS09-](#)
[EVA-KIT](#) [237](#)