

# DATA SHEET

## **NE/SA5234**

Matched quad high-performance  
low-voltage operational amplifier

Product data  
Supersedes data of 1994 Aug 31  
File under Integrated Circuits, IC11 Handbook

2001 Aug 03

# Matched quad high-performance low-voltage operational amplifier

NE/SA5234

## DESCRIPTION

The NE/SA5234 is a matched, low voltage, high performance quad operational amplifier. Among its unique input and output characteristics is the capability for both input and output rail-to-rail operation, particularly critical in low voltage applications. The output swings to less than 50 mV of both rails across the entire power supply range. The NE/SA5234 is capable of delivering 5.5 V peak-to-peak across a 600  $\Omega$  load and will typically draw only 700  $\mu$ A per amplifier. The bandwidth is 2.5 MHz and the 1% settling time is 1.4  $\mu$ s.

## FEATURES

- Wide common-mode input voltage range: 250 mV beyond both rails
- Output swing within 50 mV of both rails
- Functionality to 1.8 V typical
- Low current consumption: 700  $\mu$ A per amplifier
- $\pm 15$  mA output current capability
- Unity gain bandwidth: 2.5 MHz
- Slew rate: 0.8 V/ $\mu$ s
- Low noise: 25 nV/ $\sqrt{\text{Hz}}$
- Electrostatic discharge protection
- Short-circuit protection
- Output inversion prevention

## PIN CONFIGURATION

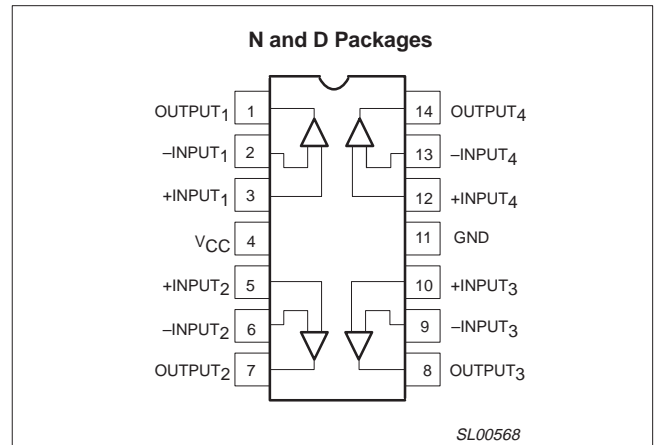

Figure 1. Pin configuration.

## APPLICATIONS

- Automotive electronics
- Signal conditioning and sensing amplification
- Portable instrumentation
  - Test and measurement
  - Medical monitors and diagnostics
  - Remote meters
- Audio equipment
- Security systems
- Communications
  - Pagers
  - Cellular telephone
  - LAN
  - 5 V Datacom bus
- Error amplifier in motor drives
- Transducer buffer amplifier

## ORDERING INFORMATION

DESCRIPTION	TEMPERATURE RANGE	ORDER CODE	DWG #
14-Pin Plastic Small Outline (SO) package	0 °C to +70 °C	NE5234D	SOT108-1
14-Pin Plastic Dual In-Line Package (DIP)	0 °C to +70 °C	NE5234N	SOT27-1
14-Pin Plastic Small Outline (SO) package	–40 °C to +85 °C	SA5234D	SOT108-1
14-Pin Plastic Dual In-Line Package (DIP)	–40 °C to +85 °C	SA5234N	SOT27-1

# Matched quad high-performance low-voltage operational amplifier

NE/SA5234

## ABSOLUTE MAXIMUM RATINGS

SYMBOL	PARAMETER	RATING	UNIT
$V_{CC}$	Single supply voltage	7	V
$V_{ESD}$	ESD protection voltage at any pin <sup>5</sup> human body model robot model	2000	V
		200	V
$V_S$	Dual supply voltage	$\pm 3.5$	V
$V_{DP}$	Voltage at any device pin <sup>1</sup>	$V_S \pm 0.5$	V
$I_{DP}$	Current into any device pin <sup>1</sup>	$\pm 50$	mA
$V_{IN}$	Differential input voltage <sup>2</sup>	0.5	V
$V_{CM}$	Common-mode input voltage (positive)	$V_{CC} + 0.5$	V
$V_{CM}$	Common-mode input voltage (negative)	$V_{EE} - 0.5$	V
$P_D$	Power dissipation <sup>3</sup>	500	mW
$T_j$	Operating junction temperature <sup>3</sup>	+150	°C
$V_{SC}$	Supply voltage allowing indefinite output short circuit to either rail <sup>3,4</sup>	7	V
$T_{stg}$	Storage temperature range	-65 to +150	°C
$T_{slid}$	Lead soldering temperature (10 sec max)	+230	°C
$\theta_{JA}$	Thermal impedance		
	14 pin Plastic DIP	80	°C/W
	14 pin Plastic SO	115	°C/W

### NOTES:

- Each pin is protected by ESD diodes. The voltage at any pin is limited by the ESD diodes.
- The differential input of each amplifier is limited by two internal diodes, connected in parallel and opposite to each other. For more differential input range, use differential resistors in series with the input pins.
- The maximum operating junction temperature is +150 °C. At elevated temperatures, devices must be derated according to the package thermal resistance and device mounting conditions. Derates above +25 °C: N package at 9.5 mW/°C; D package at 6.25 mW/°C.
- Simultaneous short circuits of two or more amplifiers to the positive or negative rail can exceed the power dissipation ratings and cause eventual destruction of the device.
- Guaranteed by design.

## RECOMMENDED OPERATING CONDITIONS

SYMBOL	PARAMETER	RATING	UNIT
$V_{CC}$	Single supply voltage	+2 to +5.5	V
$V_S$	Dual supply voltage	$\pm 1$ to $\pm 2.75$	V
$V_{CM}$	Common-mode input voltage (positive)	$V_{CC} + 0.25$	V
$V_{CM}$	Common-mode input voltage (negative)	$V_{EE} - 0.25$	V
$T_{amb}$	Temperature		
	NE5234	0 to +70	°C
	SA5234	-40 to +85	°C

# Matched quad high-performance low-voltage operational amplifier

NE/SA5234

## DC ELECTRICAL CHARACTERISTICS

 $V_{CC} = 2\text{ V to } 5.5\text{ V}$ ;  $V_{EE} = 0\text{ V}$ ;  $T_{amb} = 25\text{ }^{\circ}\text{C}$ ;  $V_{EE} < V_{CM} < V_{CC}$ ; unless otherwise stated.

SYMBOL	PARAMETER	TEST CONDITIONS	LIMITS						UNIT
			NE5234			SA5234			
			MIN	TYP	MAX	MIN	TYP	MAX	
$I_{CC}$	Supply current	$V_{CC} = 5.5\text{ V}$		2.8	4.0		2.8	4.0	mA
		$V_{CC} = 5.5\text{ V}$ over full temperature range		3.0	4.6		3.2	4.8	
$V_{OS}$	Offset voltage			$\pm 0.2$	$\pm 4$		$\pm 0.2$	$\pm 4$	mV
		Over full temperature range		$\pm 0.4$	$\pm 5$		$\pm 0.6$	$\pm 5$	
$\Delta V_{OS}/\Delta T$	Offset voltage drift with temperature			4			4		$\mu\text{V}/^{\circ}\text{C}$
$\Delta V_{OS}$	Offset voltage difference between any amplifiers in the same package at the same common mode level <sup>1</sup>			0.4	3		0.4	3	mV
		Over full temperature range		0.8	4		1.2	4	
$I_{OS}$	Offset current			$\pm 3$	$\pm 20$		$\pm 3$	$\pm 30$	nA
		Over full temperature range		$\pm 4$	$\pm 30$		$\pm 6$	$\pm 60$	
$\Delta I_{OS}/\Delta T$	Offset current drift with temperature			0.02	$\pm 0.3$		0.03	$\pm 0.3$	nA/ $^{\circ}\text{C}$
$I_B$	Input bias current <sup>1</sup>	$V_{EE} < V_{CM} < V_{EE} + 0.5\text{ V}$	-200	-90		-200	-90		nA
		Over full temperature range	-225	-100		-250	-150		
		$V_{EE} + 1\text{ V} < V_{CM} < V_{CC}$		25	70		25	75	
		Over full temperature range		35	100		35	120	
$\Delta I_B/\Delta T$	Input bias current drift with temperature			0.5			0.5		nA/ $^{\circ}\text{C}$
$\Delta I_B$	Input bias current difference between any amplifier in the same package at the same common mode level.	$V_{EE} < V_{CM} < V_{EE} + 0.5\text{ V}$		10	30		10	30	nA
		Over full temperature range		25	50		50	70	
		$V_{EE} + 1\text{ V} < V_{CM} < V_{CC}$		5	20		5	20	
		Over full temperature range		15	30		25	50	
$V_{CM}$	Common-mode input range	$V_{OS} \leq 6\text{ mV}$	$V_{EE}-0.25$		$V_{CC}+0.25$	$V_{EE}-0.25$		$V_{CC}+0.25$	V
		$V_{OS} \leq 6\text{ mV}$ over full temperature range	$V_{EE}-0.1$		$V_{CC}+0.1$	$V_{EE}-0.1$		$V_{CC}+0.1$	
CMRR	Common-mode rejection ratio, small signal	$V_{EE} < V_{CM} < V_{EE}+0.5\text{ V}$ ; $V_{EE}+1\text{ V} < V_{CM} < V_{CC}$		100		90	100		dB
		Over full temperature range		100		80	90		
	Common-mode rejection ratio, large signal	$V_{EE} < V_{CM} < V_{CC}$		90			100		
		Over full temperature range		80			90		
PSRR	Power supply rejection ratio	$V_{EE} < V_{CM} < V_{CC}$	80	100		80	100		dB
		Over full temperature range	80	90		80	90		
$I_L$	Peak load current, sink and source		10	12		10	12		mA
		Over full temperature range	5	8		5	8		

# Matched quad high-performance low-voltage operational amplifier

NE/SA5234

## DC ELECTRICAL CHARACTERISTICS (Continued)

SYMBOL	PARAMETER	TEST CONDITIONS	LIMITS						UNIT
			NE5234			SA5234			
			MIN	TYP	MAX	MIN	TYP	MAX	
$A_{VOL}$	Open-loop voltage gain		90	110		90	110		dB
		Over full temperature range		90			90		
$V_{OUT}$	Output voltage swing	$I_{PEAK} = 0.1 \text{ mA}$	$V_{EE}+0.05$		$V_{CC}-0.05$	$V_{EE}+0.1$		$V_{CC}-0.1$	V
		$I_{PEAK} = 10 \text{ mA}$	$V_{EE}+0.25$		$V_{CC}-0.25$	$V_{EE}+0.25$		$V_{CC}-0.25$	
		$I_{PEAK} = 5 \text{ mA}$ over full temperature range	$V_{EE}+0.22$		$V_{CC}-0.2$	$V_{EE}+0.2$		$V_{CC}-0.2$	
	Output voltage swing for $V_{CC} = 2.75 \text{ V}$ ; $V_{EE} = -2.75 \text{ V}$	$R_L = 2 \text{ k}\Omega$	$V_{EE}+0.2$		$V_{CC}-0.2$	$V_{EE}+0.2$		$V_{CC}-0.2$	V
		$R_L = 600 \Omega$	$V_{EE}+0.25$		$V_{CC}-0.25$	$V_{EE}+0.25$		$V_{CC}-0.25$	V

**NOTE:**

- These parameters are measured for  $V_{EE} < V_{CM} < V_{EE}+0.5 \text{ V}$  and for  $V_{EE}+1 \text{ V} < V_{CM} < V_{CC}$ . By design these parameters are intermediate for common mode ranges between the measured regions.

## AC ELECTRICAL CHARACTERISTICS

$T_{amb} = +25 \text{ }^\circ\text{C}$ ;  $V_{CC} = 2 \text{ V}$  to  $5.5 \text{ V}$ ;  $R_L = 10 \text{ k}\Omega$ ;  $C_L = 100 \text{ pF}$ ; unless otherwise stated.

SYMBOL	PARAMETER	TEST CONDITIONS	LIMITS						UNITS
			NE5234			SA/SE5234			
			MIN	TYP	MAX	MIN	TYP	MAX	
SR	Slew rate	Over full temperature range	0.5	0.8		0.5	0.8		V/ $\mu\text{s}$
BW	Unity gain bandwidth: -3 dB	Over full temperature range	2	2.5	4.0	2	2.5	4.0	MHz
$\theta_M$	Phase Margin	$C_L = 50 \text{ pF}$		55			55		deg
$t_S$	1% settling time	$A_V = 1$ , 1 V step		1.4			1.4		$\mu\text{s}$
$V_N$	Input referred voltage noise	$A_V = 1$ ; $R_S = 0 \Omega$ , at 1 kHz		25			25		nV/Hz <sup>1/2</sup>
THD	Total harmonic distortion	10 kHz, 1 V <sub>P-P</sub> , $A_V = 1$		0.1			0.1		%

## OUTPUT INVERSION PREVENTION

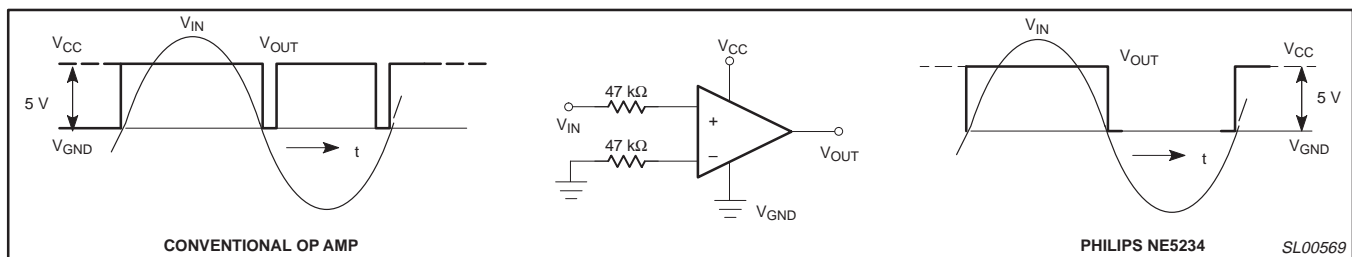

Figure 2. Output inversion prevention.

# Matched quad high-performance low-voltage operational amplifier

NE/SA5234

SO14: plastic small outline package; 14 leads; body width 3.9 mm

SOT108-1

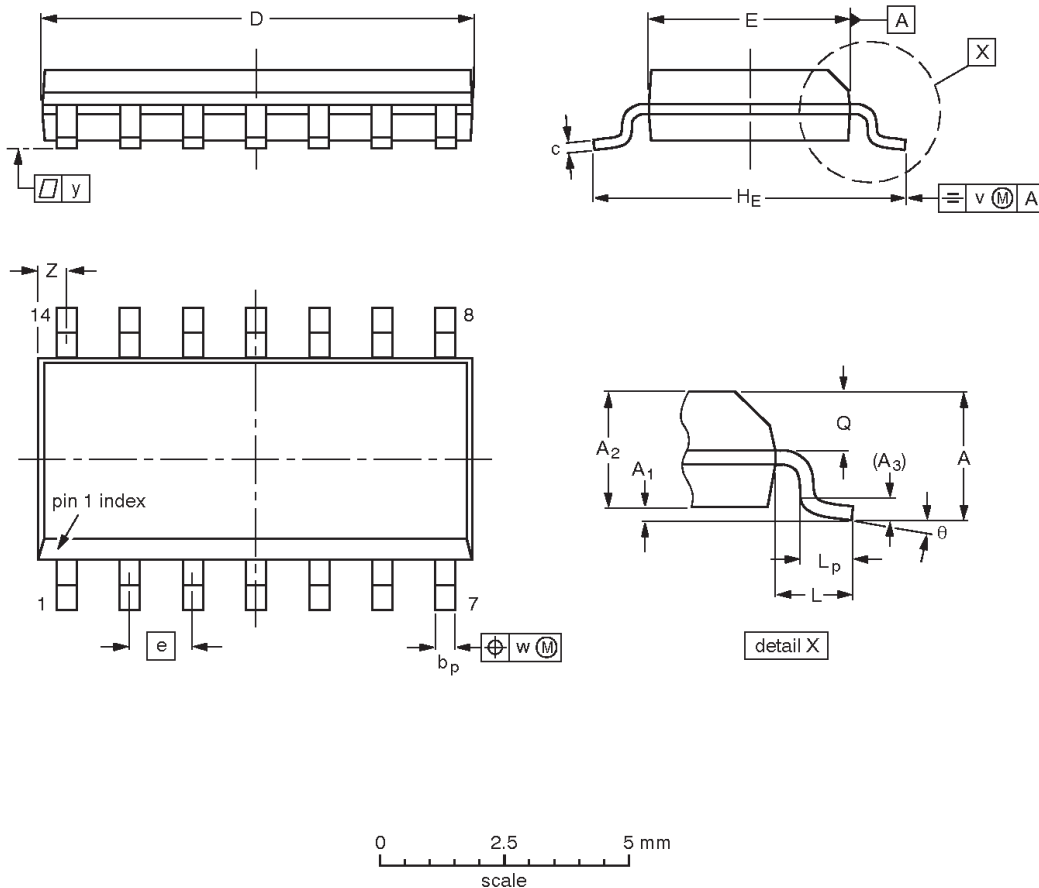

**DIMENSIONS (inch dimensions are derived from the original mm dimensions)**

UNIT	A max.	A <sub>1</sub>	A <sub>2</sub>	A <sub>3</sub>	b <sub>p</sub>	c	D <sup>(1)</sup>	E <sup>(1)</sup>	e	H <sub>E</sub>	L	L <sub>p</sub>	Q	v	w	y	Z <sup>(1)</sup>	θ
mm	1.75	0.25 0.10	1.45 1.25	0.25	0.49 0.36	0.25 0.19	8.75 8.55	4.0 3.8	1.27	6.2 5.8	1.05	1.0 0.4	0.7 0.6	0.25	0.25	0.1	0.7 0.3	8° 0°
inches	0.069	0.010 0.004	0.057 0.049	0.01	0.019 0.014	0.0100 0.0075	0.35 0.34	0.16 0.15	0.050	0.244 0.228	0.041	0.039 0.016	0.028 0.024	0.01	0.01	0.004	0.028 0.012	

**Note**

1. Plastic or metal protrusions of 0.15 mm maximum per side are not included.

OUTLINE VERSION	REFERENCES				EUROPEAN PROJECTION	ISSUE DATE
	IEC	JEDEC	EIAJ			
SOT108-1	076E06	MS-012				97-05-22 99-12-27

# Matched quad high-performance low-voltage operational amplifier

NE/SA5234

DIP14: plastic dual in-line package; 14 leads (300 mil)

SOT27-1

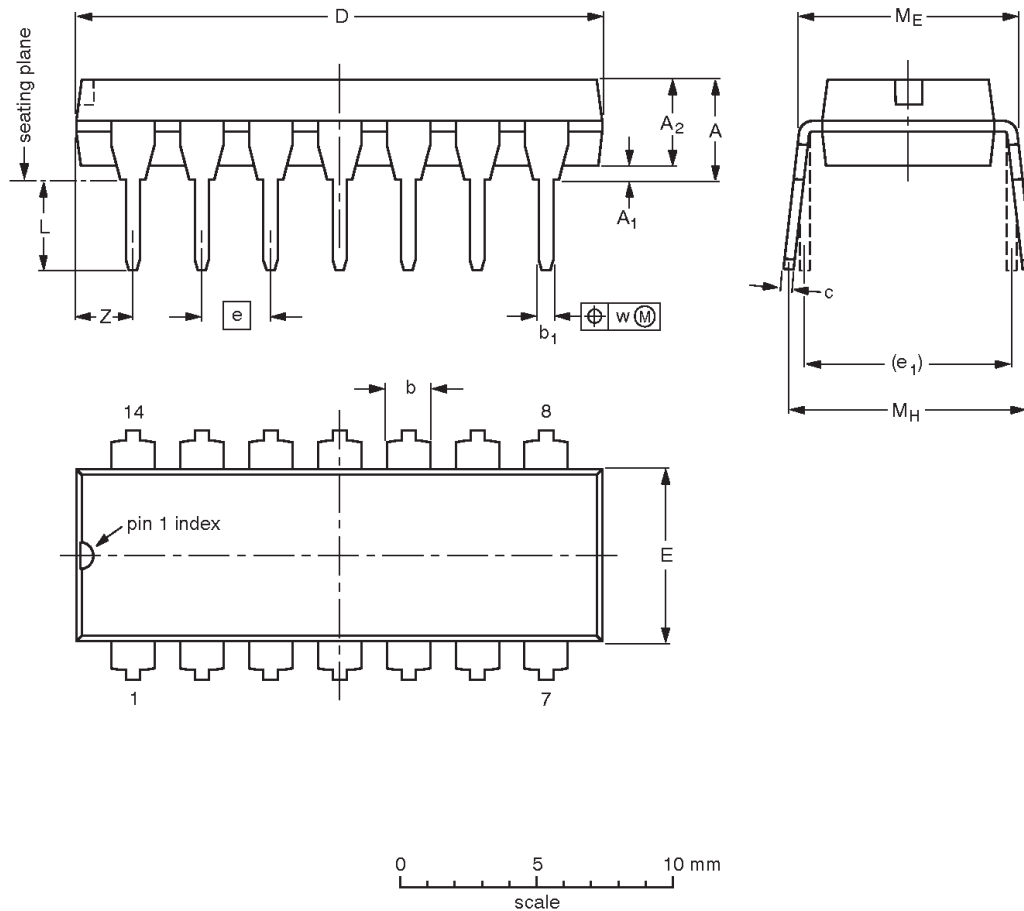

**DIMENSIONS (inch dimensions are derived from the original mm dimensions)**

UNIT	A max.	A <sub>1</sub> min.	A <sub>2</sub> max.	b	b <sub>1</sub>	c	D <sup>(1)</sup>	E <sup>(1)</sup>	e	e <sub>1</sub>	L	M <sub>E</sub>	M <sub>H</sub>	w	Z <sup>(1)</sup> max.
mm	4.2	0.51	3.2	1.73 1.13	0.53 0.38	0.36 0.23	19.50 18.55	6.48 6.20	2.54	7.62	3.60 3.05	8.25 7.80	10.0 8.3	0.254	2.2
inches	0.17	0.020	0.13	0.068 0.044	0.021 0.015	0.014 0.009	0.77 0.73	0.26 0.24	0.10	0.30	0.14 0.12	0.32 0.31	0.39 0.33	0.01	0.087

**Note**

1. Plastic or metal protrusions of 0.25 mm maximum per side are not included.

OUTLINE VERSION	REFERENCES				EUROPEAN PROJECTION	ISSUE DATE
	IEC	JEDEC	EIAJ			
SOT27-1	050G04	MO-001	SC-501-14			95-03-11 99-12-27

# Matched quad high-performance low-voltage operational amplifier

NE/SA5234

## Data sheet status

Data sheet status <sup>[1]</sup>	Product status <sup>[2]</sup>	Definitions
Objective data	Development	This data sheet contains data from the objective specification for product development. Philips Semiconductors reserves the right to change the specification in any manner without notice.
Preliminary data	Qualification	This data sheet contains data from the preliminary specification. Supplementary data will be published at a later date. Philips Semiconductors reserves the right to change the specification without notice, in order to improve the design and supply the best possible product.
Product data	Production	This data sheet contains data from the product specification. Philips Semiconductors reserves the right to make changes at any time in order to improve the design, manufacturing and supply. Changes will be communicated according to the Customer Product/Process Change Notification (CPCN) procedure SNW-SQ-650A.

[1] Please consult the most recently issued data sheet before initiating or completing a design.

[2] The product status of the device(s) described in this data sheet may have changed since this data sheet was published. The latest information is available on the Internet at URL <http://www.semiconductors.philips.com>.

## Definitions

**Short-form specification** — The data in a short-form specification is extracted from a full data sheet with the same type number and title. For detailed information see the relevant data sheet or data handbook.

**Limiting values definition** — Limiting values given are in accordance with the Absolute Maximum Rating System (IEC 60134). Stress above one or more of the limiting values may cause permanent damage to the device. These are stress ratings only and operation of the device at these or at any other conditions above those given in the Characteristics sections of the specification is not implied. Exposure to limiting values for extended periods may affect device reliability.

**Application information** — Applications that are described herein for any of these products are for illustrative purposes only. Philips Semiconductors make no representation or warranty that such applications will be suitable for the specified use without further testing or modification.

## Disclaimers

**Life support** — These products are not designed for use in life support appliances, devices or systems where malfunction of these products can reasonably be expected to result in personal injury. Philips Semiconductors customers using or selling these products for use in such applications do so at their own risk and agree to fully indemnify Philips Semiconductors for any damages resulting from such application.

**Right to make changes** — Philips Semiconductors reserves the right to make changes, without notice, in the products, including circuits, standard cells, and/or software, described or contained herein in order to improve design and/or performance. Philips Semiconductors assumes no responsibility or liability for the use of any of these products, conveys no license or title under any patent, copyright, or mask work right to these products, and makes no representations or warranties that these products are free from patent, copyright, or mask work right infringement, unless otherwise specified.

## Contact information

For additional information please visit  
<http://www.semiconductors.philips.com>. Fax: +31 40 27 24825

© Koninklijke Philips Electronics N.V. 2002  
 All rights reserved. Printed in U.S.A.

For sales offices addresses send e-mail to:  
[sales.addresses@www.semiconductors.philips.com](mailto:sales.addresses@www.semiconductors.philips.com)

Document order number:

Date of release: 01-02

9397 750 09294

*Let's make things better.*



## X-ON Electronics

Largest Supplier of Electrical and Electronic Components

*Click to view similar products for [Operational Amplifiers - Op Amps](#) category:*

*Click to view products by [NXP](#) manufacturer:*

Other Similar products are found below :

[OPA2991IDSGR](#) [OPA607IDCKT](#) [007614D](#) [633773R](#) [635798C](#) [635801A](#) [702115D](#) [709228FB](#) [741528D](#) [NCV33072ADR2G](#)  
[SC2902DTBR2G](#) [SC2903DR2G](#) [SC2903VDR2G](#) [LM258AYDT](#) [LM358SNG](#) [430227FB](#) [430228DB](#) [460932C](#) [AZV831KTR-G1](#) [409256CB](#)  
[430232AB](#) [LM2904DR2GH](#) [LM358YDT](#) [LT1678IS8](#) [042225DB](#) [058184EB](#) [070530X](#) [SC224DR2G](#) [SC239DR2G](#) [SC2902DG](#)  
[SCYA5230DR2G](#) [714228XB](#) [714846BB](#) [873836HB](#) [MIC918YC5-TR](#) [TS912BIYDT](#) [NCS2004MUTAG](#) [NCV33202DMR2G](#)  
[M38510/13101BPA](#) [NTE925](#) [SC2904DR2G](#) [SC358DR2G](#) [LM358EDR2G](#) [AZV358MTR-G1](#) [AP4310AUMTR-AG1](#) [HA1630D02MMEL-E](#)  
[NJM358CG-TE2](#) [HA1630S01LPEL-E](#) [LM324AWPT](#) [HA1630Q06TELL-E](#)