



UM10791

SSL5021BDB1205 120 V 6 W candle form non-isolated buck LED driver demo board

Rev. 1 — 3 November 2014

User manual

Document information

Info	Content
Keywords	SSL5021BDB1205, SSL5021BTS, LED driver, non-isolated buck topology, candle applications, TSOP6 package
Abstract	<p>This user manual describes the performance, technical data, and the connection of the SSL5021BDB1205 demo board, using non-isolated buck topology.</p> <p>The SSL5021BTS is an NXP Semiconductors driver IC in a TSOP6 package. It is intended to provide a low-cost, small form factor LED driver design.</p> <p>This SSL5021BDB1205 demo board is designed for candle-form applications. It operates at 120 V (AC), with an output voltage approximately 54 V.</p>



Revision history

Rev	Date	Description
v.1	20141103	first issue

Contact information

For more information, please visit: <http://www.nxp.com>

For sales office addresses, please send an email to: salesaddresses@nxp.com

1. Introduction

WARNING

Lethal voltage and fire ignition hazard



The non-insulated high voltages that are present when operating this product, constitute a risk of electric shock, personal injury, death and/or ignition of fire.

This product is intended for evaluation purposes only. It shall be operated in a designated test area by personnel qualified according to local requirements and labor laws to work with non-insulated mains voltages and high-voltage circuits. This product shall never be operated unattended.

This user manual describes the operation of the SSL5021BDB1205 demo board featuring LED driver SSL5021BTS in a 120 V/6 W non-isolated application.

The SSL5021BDB1205 demo board is designed for driving LED loads from 40 V to 60 V with a nominal value of 55 V.

The PCB dimensions are compatible with candle applications.

The SSL5021BDB1205 demo board provides a simple and effective solution with a low output current ripple and high efficiency for Solid-State Lighting (SSL) applications.

1.1 Features

- Candle-form application
- Open/short LED string protection
- OverCurrent Protection (OCP)
- OverTemperature Protection (OTP)
- Efficiency > 88 % at 120 V (AC) input
- Compliant with IEC61000-3-2 harmonic standard
- Compliant with EN55015 conducted EMI

2. Safety warning

The demo board input is connected to the mains voltage. Avoid touching the board while it is connected to the mains voltage and when it is in operation. An isolated housing is obligatory when used in uncontrolled, non-laboratory environments. Galvanic isolation from the mains phase using a fixed or variable transformer is always recommended. [Figure 1](#) shows the symbols on how to recognize these devices.

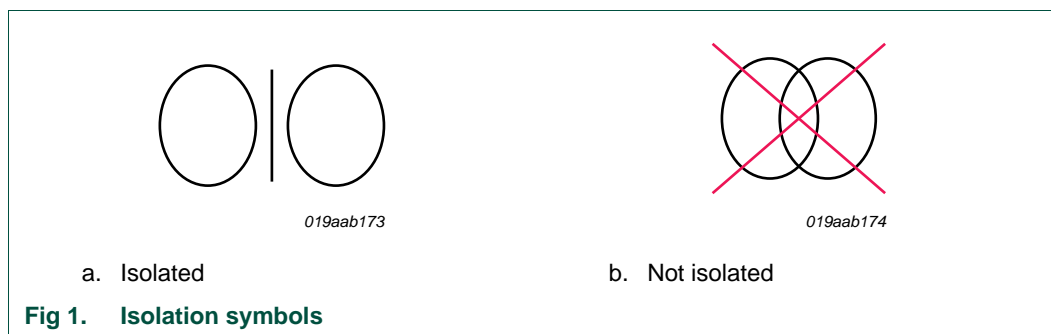

3. Specifications

[Table 1](#) lists the specification of the SSL5021BDB1205 demo board.

Table 1. SSL5021BDB1205 specifications

Symbol	Parameter	Value
V_{mains}	AC mains supply voltage	120 V (AC); $\pm 10\%$
P_{out}	output power	6 W
V_{LED}	output voltage	40 V to 60 V (54 V optimum)
I_{LED}	output current	93 mA
I_{ripple}	output current ripple at 120 Hz	< 3 %
$\Delta I_{\text{LED}}(V_{\text{mains}})/I_{\text{LED}}(\text{nom})$	line regulation	1.0 % at $V_{\text{mains}} = 90\text{ V to }150\text{ V}$
$\Delta I_{\text{LED}}(V_{\text{LED}})/I_{\text{LED}}(\text{nom})$	load regulation	0.7 % at $V_{\text{LED}}, \pm 10\%$
η	efficiency	89 %; at 120 V (AC)/-60 Hz
PF	power factor	>0.55 at 120 V (AC)/-60 Hz
T_{oper}	operating temperature	-40 °C to +105 °C
	board dimensions	60 mm × 40 mm
	conducted electrostatic Interference (EMI)	EN55015
	IEC61000-3-2	Class D (for $P_{\text{in}} < 25\text{ W}$ limit)

Figure 2 shows the dimensions of the demo board.



4. Board photographs

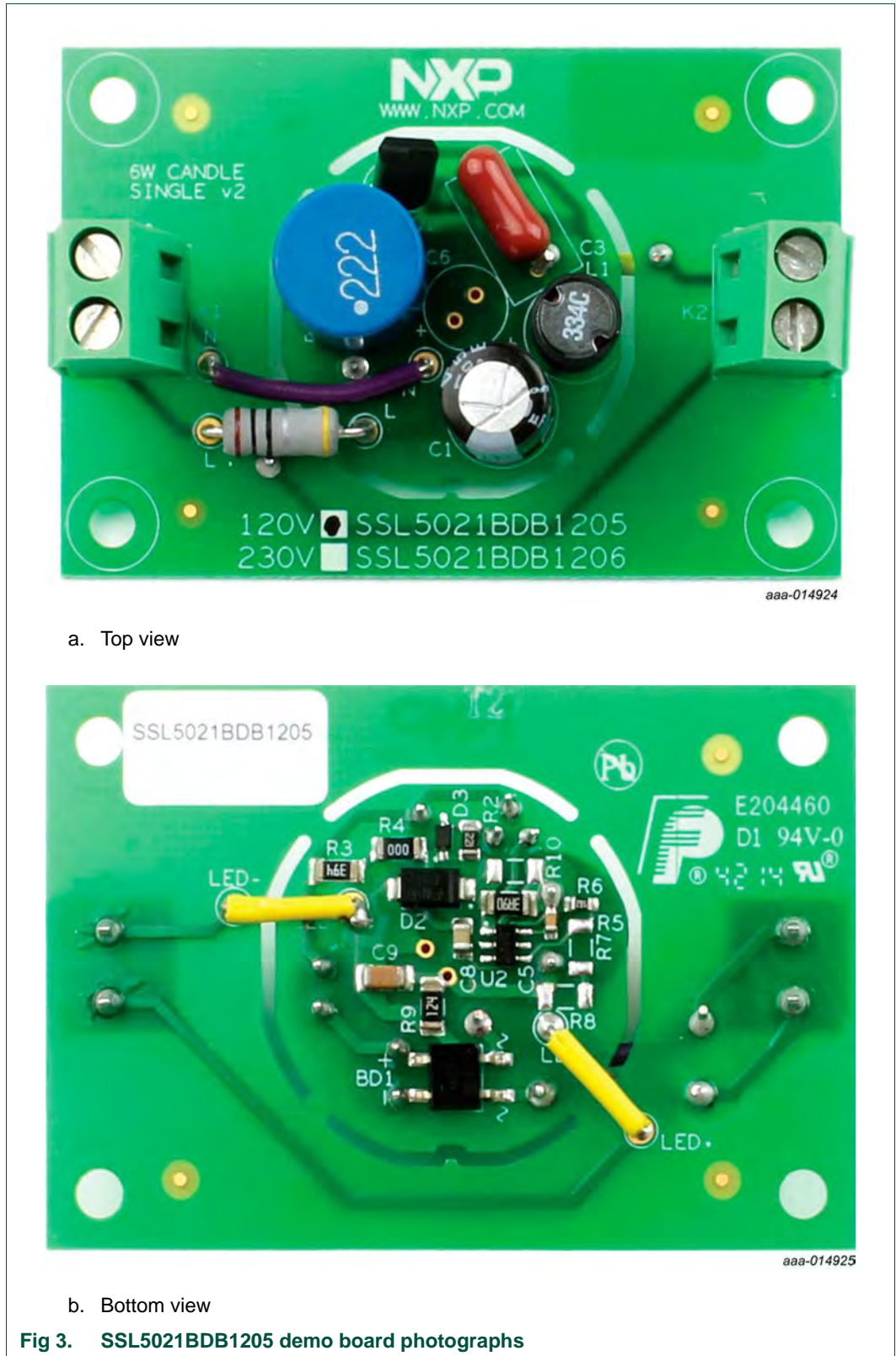

5. Board connections

The SSL5021BDB1205 demo board is optimized for a 120 V (AC)/60 Hz supply. It is designed to work with multiple LEDs or an LED module.

Under the expected conditions, the output current is 93 mA when using an LED string with a 55 V forward voltage (V_F). The current can be adjusted using resistors R5. A 55 V LED voltage gives a good efficiency and line regulation at 120 V (AC).

K1 is the connection for the mains voltage. LED+ and LED- are the connections for the LED load. [Figure 4](#) shows the connections.



Fig 4. SSL5021BDB1205 board connections

6. Functional description

6.1 Input filtering

Capacitors C1 and C3 and inductor L1 filter the switching current from the buck converter to the line. Capacitors C1 and C3 also provide a low-impedance path for the switching current. The value of C1 is selected to have no more than 30 % ripple on the bus voltage at -15 % of typical mains.

The input series resistance of 10 Ω and capacitor C1 together provide adequate protection against transient surge voltages. A footprint for an optional varistor RV1 is available on the board. To increase the immunity to the line surge, the input resistance is added (see [Figure 11](#)). Do not omit this resistor or lower its value.

6.2 Efficiency improvement for universal mains

The SSL5021BTS is supplied via start-up resistors R3 and R4. To keep the temperature low and retain ease of adjustment of the desired value, the power losses in these resistors are divided over the two resistors.

For mains voltages up to 120 V (AC), a single 1206 size SMD resistor (R3) is sufficient. The maximum voltage and the power rating are not exceeded.

6.3 Open-load protection

The driver board is protected when the LED load is accidentally left open. The open-load protection is a non-latched protection. Two circuits set the open-load output voltage. One circuit sets the open-load output voltage when the IC does not operate because of a defect. The other circuit sets it when the IC is operating normally. In all cases, the output voltage must never exceed the rated DC voltage of the output capacitor.

Do not reconnect the LEDs directly after an open-load situation. The output capacitor is charged to a higher voltage than the total LED voltage, forcing an uncontrolled discharge current through the LEDs when connected. It can damage the LEDs permanently.

IC not operating:

The voltage divider consisting of resistors R3 and R4 sets the output voltage from the VCC pin of the IC to the GND pin of the IC and resistor R9.

$$V_{out} = \frac{(V_{drain} - 15) \cdot R9}{(R3 + R4 + R9)} \quad (1)$$

As a rule of thumb, limit resistor R9 to $\frac{(n \times 2.5 \text{ V})}{225 \mu\text{A}}$. In this way, the voltage is not sufficient to illuminate the LEDs (n is the number of LEDs in series at the output).

The non-operating output voltage must not be equal to or exceed the voltage set by the operating mode. It is good practice to set the level in non-operating mode 5 V to 10 V lower than in operating mode.

IC operating:

When the voltage in the non-operating mode is set to a safe level for the output capacitor, the voltage in the operating mode can be set. The DEMOVP pin detects overvoltage. It triggers when 4 consecutive high-frequency cycles at 1.8 V are detected at the DEMOVP

pin. $V_{out} = 1.8 \cdot \frac{(R6 + R7 + R8)}{(R6)}$ sets the output voltage.

The output voltage must never exceed the rated DC voltage of the output capacitor.

6.4 External overtemperature protection and LED current foldback

[Figure 11](#) shows the footprints of resistors R5 and R6. The purpose of these resistors is to provide thermal protection. To reduce light output when using output current foldback, the DEMOVP pin can be used as an input. Replace resistor R5 by a 470 Ω PTC resistor. Resistor R6 is kept at 5.1 k Ω . If the foldback option is not used, resistor R5 can be shorted and resistor R6 can be set to 5.6 k Ω .

When the foldback option is not used, efficiency can be further improved by increasing R6 to 12 k Ω . Do not use a value > 18 k Ω for resistor R6. If the value of resistor R6 is increased too much, the DEMOVP pin can cause false OVP triggering.

6.5 LED current and sense resistors

To optimally profit from the excellent current stability of the SSL5021BTS, overtemperature 50 ppm MELF type resistors are chosen to sense the LED current. The output current stability range drops to 3 % compared to 7 % over the full temperature range for normal 200 ppm 1206 type resistors.

In most low-power, low-cost applications with LED currents < 150 mA, 200 ppm resistors are fine. $I_{LED(AV)} = 0.4 / R5$ can adjust the average LED current. If the change is small ($\pm 10\%$), changing the inductor is not required. At the lowest mains voltage, the maximum ON-time of Q1 must not exceed 15 μ s.

When the sense resistor is operating at high temperatures, its power rating must be rated by a factor 2.

7. Performance

$V_{\text{mains}} = 85 \text{ V to } 140 \text{ V (AC)}$; $t_{\text{amb}} = 25 \text{ }^\circ\text{C}$; $I_{\text{LED}} = 93 \text{ mA typical}$; $V_{\text{LED}} = 55 \text{ V}$ unless otherwise specified.

7.1 Efficiency

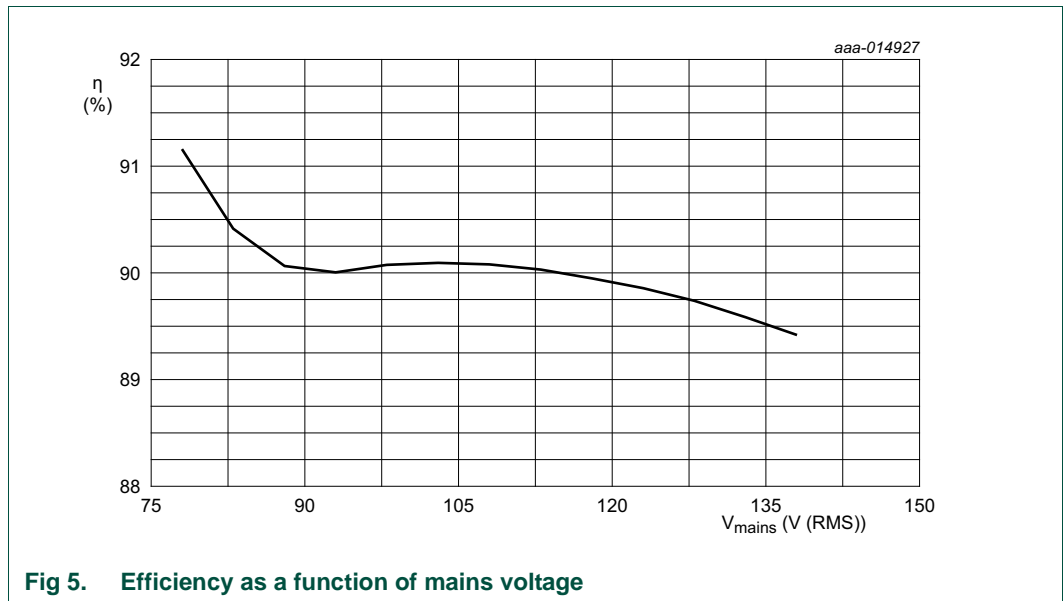

7.2 Input power

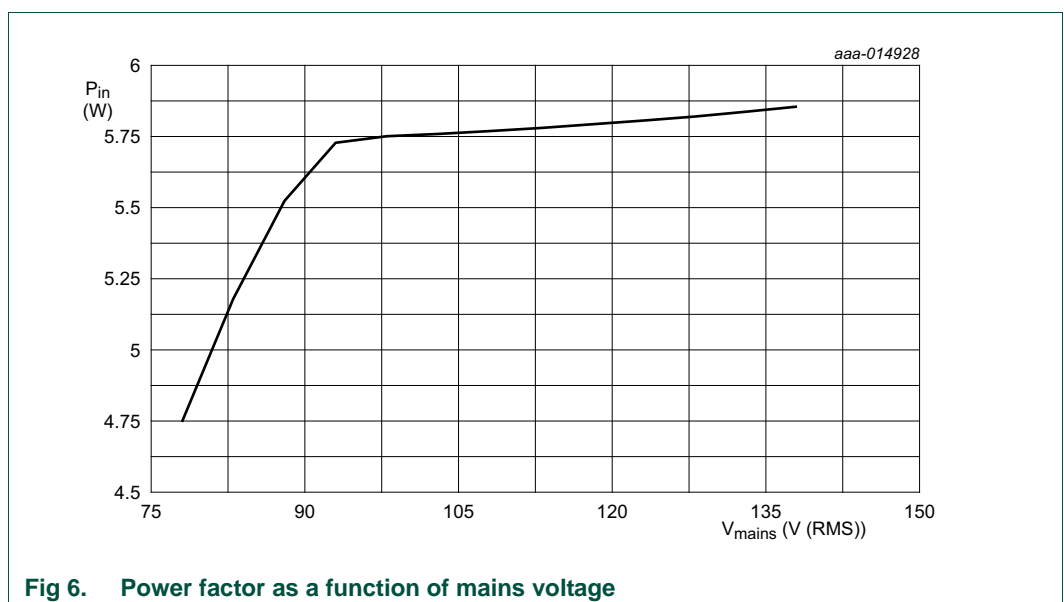

7.3 Line regulation

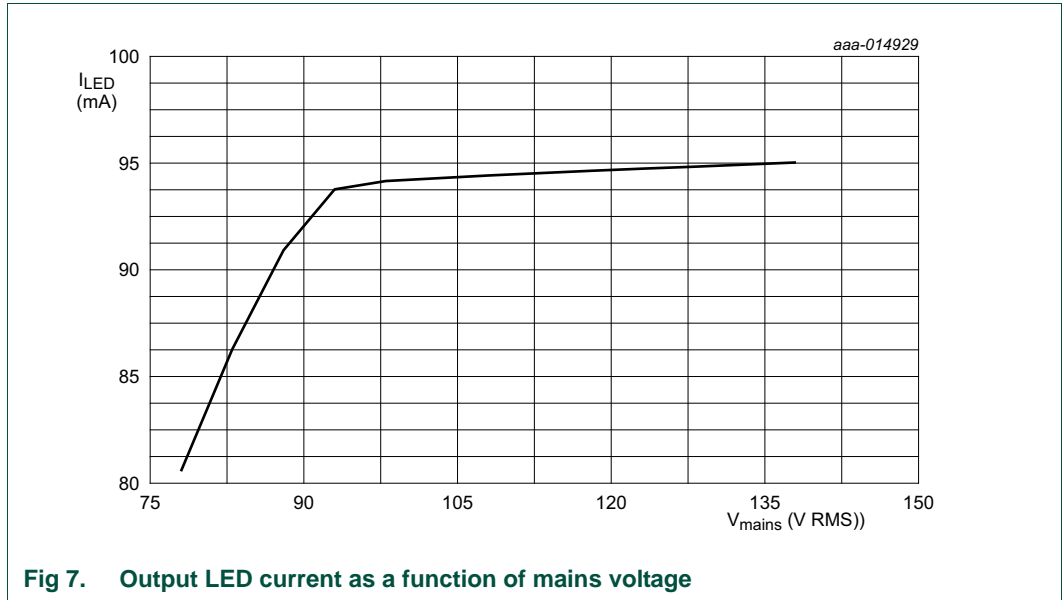

7.4 Load regulation

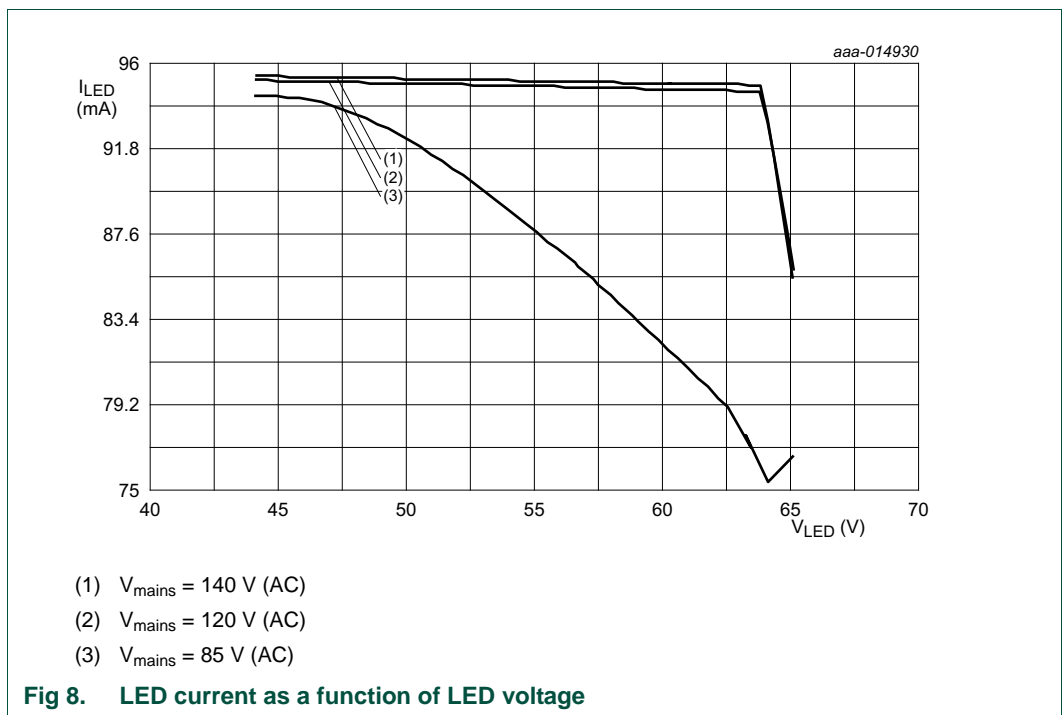

7.5 Output ripple

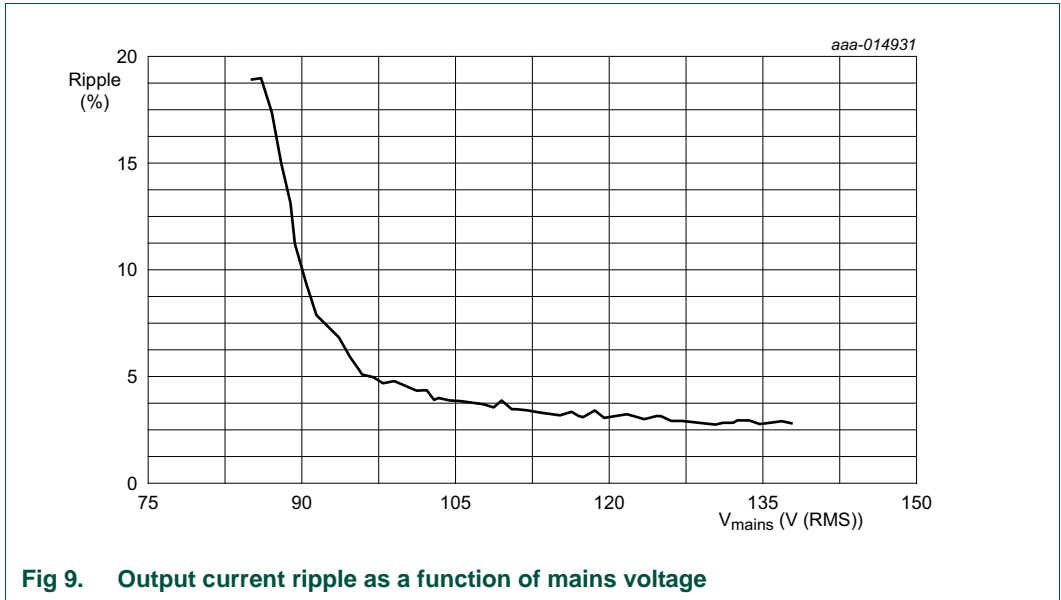

Fig 9. Output current ripple as a function of mains voltage

7.6 ElectroMagnetic Interference (EMI)

Figure 10 shows the conducted EMI result of the SSL5021BDB1205 demo board.

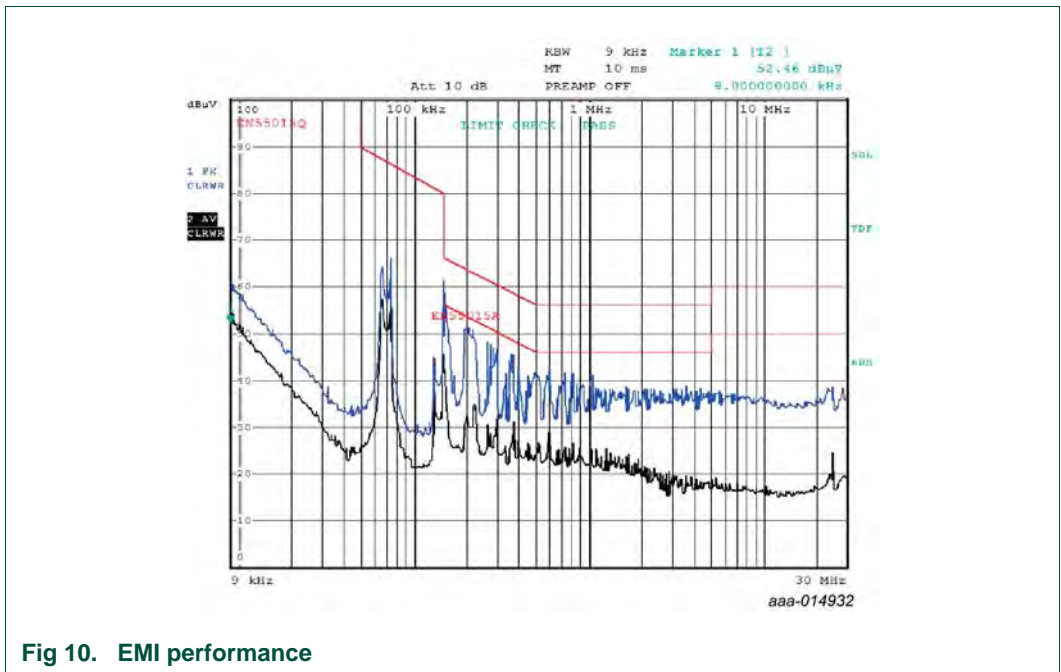

Fig 10. EMI performance

8. Schematic

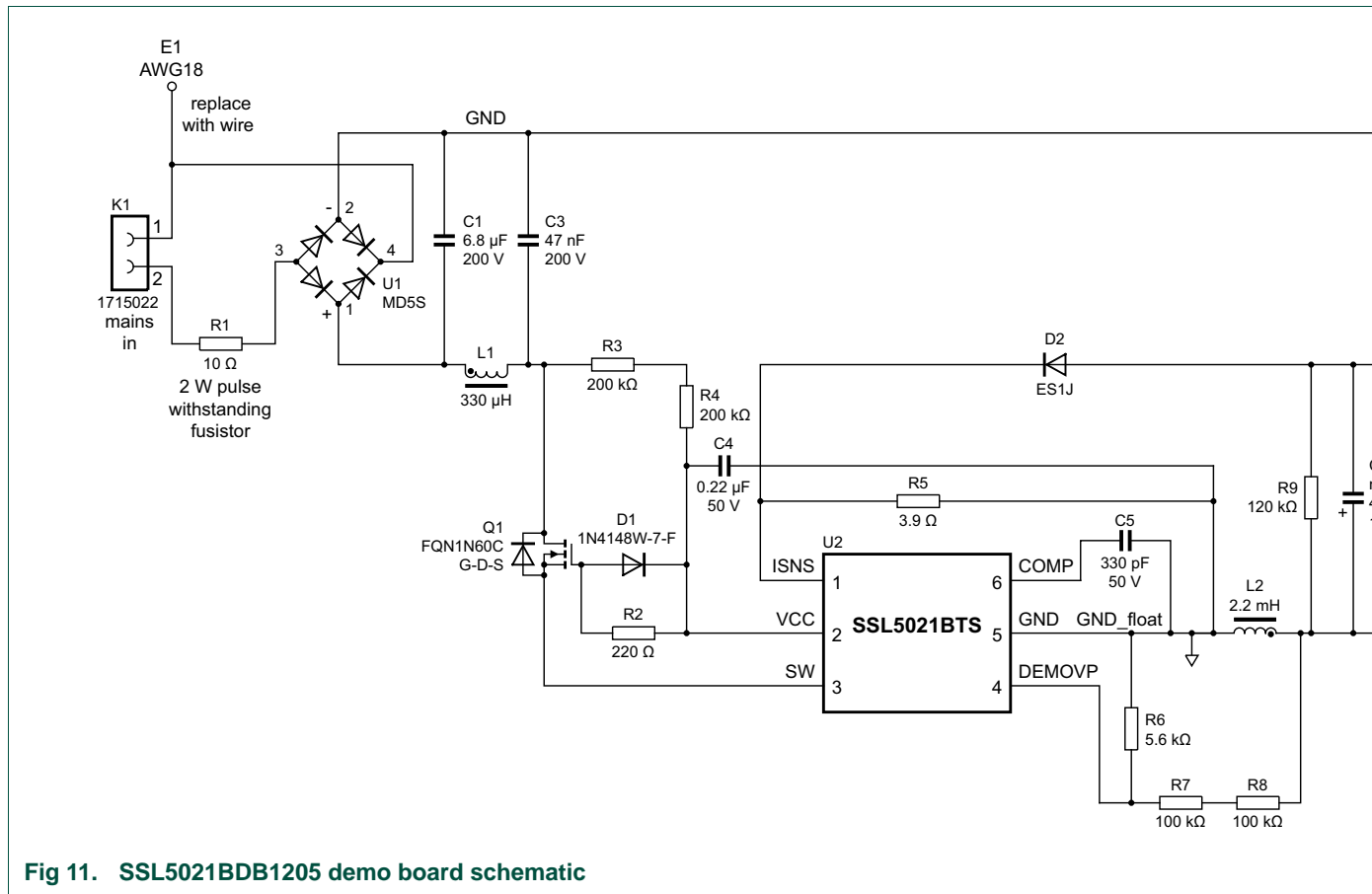

Fig 11. SSL5021BDB1205 demo board schematic

9. Bill Of Materials (BOM)

Table 2. SSL5021BDB1205 bill of materials

Reference	Description and values	Part number	Manufacturer
C1	capacitor; 6.8 μ F; 200 V	-	Rubycon
C3	capacitor; 0.047 μ F; 400 V	CL21-400V-0.047 μ F-K	ZhongShan AIDI Electronics
C4	capacitor; 0.22 μ F; 10 %; 50 V; X7R; 0603	UMK107B7224KA-TR	Taiyo Yuden
C5	capacitor; 330 pF; 630 V; 0805	C2012C0G2W330J060AA	TDK
C6	capacitor; 4.7 μ F; 100 V	100ZLJM	Rubycon
C9	capacitor; 100 nF; 200 V	C1206C104K2RACTU	KEMET
D1	diode; 100 V; 300 mA	1N4148W-7-F	Diodes Incorporated
D2	diode; fast; 600 V; 1 A	MURS160-E3-52T	Vishay
K1	terminal block; 2 p.; 5.08 mm	1508060000	Weidmüller
K2	terminal block; 2 p.; 5.08 mm	20020109-H021A01LF	FCI
L1	inductor; 330 μ H	RLB0812-681KL	Bourns
L2	inductor; 2.2 mH	TSL1112RA-222JR33-PF	TDK
Q1	MOSFET-N; 650 V; 0.8 A	FQN1N60C	Fairchild
R1	resistor; 22 Ω ; 10 %; 2 W; EMC	EMC2-22RK	Welwyn Components
R2	resistor; 220 Ω ; 1 %; 125 mW; 0603	-	-
R3; R4	resistor; 560 k Ω ; 1206	-	-
R5	resistor; 4.3 Ω ; 1 %; 63 mW; 1206	-	-
R6	resistor; 5.6 k Ω ; 1 %; 63 mW; 0603	-	-
R7	resistor; 100 k Ω ; 1 %; 250 mW; 1206	-	-
R8	resistor; 100 k Ω ; 1 %; 250 mW; 1206	-	-
R9	resistor; 220 k Ω ; 1 %; 250 mW; 1206	-	-
U1	bridge rectifier; 600 V; 0.8 A	B6S-G	Comchip Tech
U2	IC; SSL5021BTS; TSOP6	SSL5021BTS	NXP Semiconductors

10. Board layout

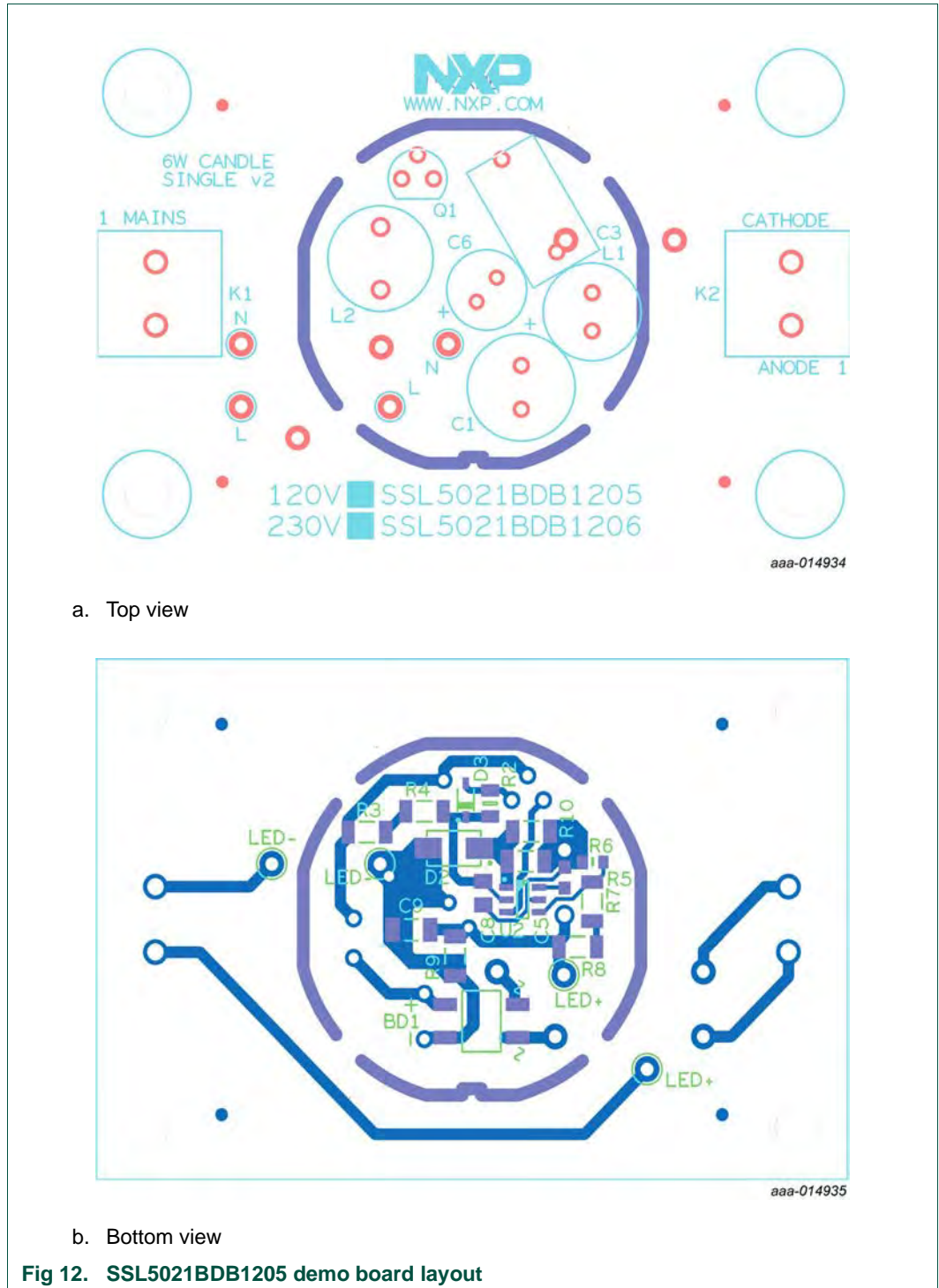

11. Abbreviations

Table 3. Abbreviations

Acronym	Description
EMI	ElectroMagnetic Interference
LED	Light-Emitting Diode
OCP	OverCurrent Protection
OTP	OverTemperature Protection
PF	Power Factor
SSL	Solid-State Lighting

12. References

- [1] [SSL5021BTS data sheet](#) — Compact low-ripple buck LED driver IC

13. Legal information

13.1 Definitions

Draft — The document is a draft version only. The content is still under internal review and subject to formal approval, which may result in modifications or additions. NXP Semiconductors does not give any representations or warranties as to the accuracy or completeness of information included herein and shall have no liability for the consequences of use of such information.

13.2 Disclaimers

Limited warranty and liability — Information in this document is believed to be accurate and reliable. However, NXP Semiconductors does not give any representations or warranties, expressed or implied, as to the accuracy or completeness of such information and shall have no liability for the consequences of use of such information. NXP Semiconductors takes no responsibility for the content in this document if provided by an information source outside of NXP Semiconductors.

In no event shall NXP Semiconductors be liable for any indirect, incidental, punitive, special or consequential damages (including - without limitation - lost profits, lost savings, business interruption, costs related to the removal or replacement of any products or rework charges) whether or not such damages are based on tort (including negligence), warranty, breach of contract or any other legal theory.

Notwithstanding any damages that customer might incur for any reason whatsoever, NXP Semiconductors' aggregate and cumulative liability towards customer for the products described herein shall be limited in accordance with the *Terms and conditions of commercial sale* of NXP Semiconductors.

Right to make changes — NXP Semiconductors reserves the right to make changes to information published in this document, including without limitation specifications and product descriptions, at any time and without notice. This document supersedes and replaces all information supplied prior to the publication hereof.

Suitability for use — NXP Semiconductors products are not designed, authorized or warranted to be suitable for use in life support, life-critical or safety-critical systems or equipment, nor in applications where failure or malfunction of an NXP Semiconductors product can reasonably be expected to result in personal injury, death or severe property or environmental damage. NXP Semiconductors and its suppliers accept no liability for inclusion and/or use of NXP Semiconductors products in such equipment or applications and therefore such inclusion and/or use is at the customer's own risk.

Applications — Applications that are described herein for any of these products are for illustrative purposes only. NXP Semiconductors makes no representation or warranty that such applications will be suitable for the specified use without further testing or modification.

Customers are responsible for the design and operation of their applications and products using NXP Semiconductors products, and NXP Semiconductors accepts no liability for any assistance with applications or customer product design. It is customer's sole responsibility to determine whether the NXP Semiconductors product is suitable and fit for the customer's applications and products planned, as well as for the planned application and use of customer's third party customer(s). Customers should provide appropriate design and operating safeguards to minimize the risks associated with their applications and products.

NXP Semiconductors does not accept any liability related to any default, damage, costs or problem which is based on any weakness or default in the customer's applications or products, or the application or use by customer's third party customer(s). Customer is responsible for doing all necessary testing for the customer's applications and products using NXP Semiconductors products in order to avoid a default of the applications and the products or of the application or use by customer's third party customer(s). NXP does not accept any liability in this respect.

Export control — This document as well as the item(s) described herein may be subject to export control regulations. Export might require a prior authorization from competent authorities.

Evaluation products — This product is provided on an "as is" and "with all faults" basis for evaluation purposes only. NXP Semiconductors, its affiliates and their suppliers expressly disclaim all warranties, whether express, implied or statutory, including but not limited to the implied warranties of non-infringement, merchantability and fitness for a particular purpose. The entire risk as to the quality, or arising out of the use or performance, of this product remains with customer.

In no event shall NXP Semiconductors, its affiliates or their suppliers be liable to customer for any special, indirect, consequential, punitive or incidental damages (including without limitation damages for loss of business, business interruption, loss of use, loss of data or information, and the like) arising out of the use of or inability to use the product, whether or not based on tort (including negligence), strict liability, breach of contract, breach of warranty or any other theory, even if advised of the possibility of such damages.

Notwithstanding any damages that customer might incur for any reason whatsoever (including without limitation, all damages referenced above and all direct or general damages), the entire liability of NXP Semiconductors, its affiliates and their suppliers and customer's exclusive remedy for all of the foregoing shall be limited to actual damages incurred by customer based on reasonable reliance up to the greater of the amount actually paid by customer for the product or five dollars (US\$5.00). The foregoing limitations, exclusions and disclaimers shall apply to the maximum extent permitted by applicable law, even if any remedy fails of its essential purpose.

Safety of high-voltage evaluation products — The non-insulated high voltages that are present when operating this product, constitute a risk of electric shock, personal injury, death and/or ignition of fire. This product is intended for evaluation purposes only. It shall be operated in a designated test area by personnel that is qualified according to local requirements and labor laws to work with non-insulated mains voltages and high-voltage circuits.

The product does not comply with IEC 60950 based national or regional safety standards. NXP Semiconductors does not accept any liability for damages incurred due to inappropriate use of this product or related to non-insulated high voltages. Any use of this product is at customer's own risk and liability. The customer shall fully indemnify and hold harmless NXP Semiconductors from any liability, damages and claims resulting from the use of the product.

Translations — A non-English (translated) version of a document is for reference only. The English version shall prevail in case of any discrepancy between the translated and English versions.

13.3 Trademarks

Notice: All referenced brands, product names, service names and trademarks are the property of their respective owners.

GreenChip — is a trademark of NXP Semiconductors N.V.

14. Contents

1	Introduction	3
1.1	Features	3
2	Safety warning	4
3	Specifications	4
4	Board photographs	6
5	Board connections	7
6	Functional description	7
6.1	Input filtering	7
6.2	Efficiency improvement for universal mains	7
6.3	Open-load protection	8
6.4	External overtemperature protection and LED current foldback	8
6.5	LED current and sense resistors	9
7	Performance	10
7.1	Efficiency	10
7.2	Input power	10
7.3	Line regulation	11
7.4	Load regulation	11
7.5	Output ripple	12
7.6	ElectroMagnetic Interference (EMI)	12
8	Schematic	13
9	Bill Of Materials (BOM)	14
10	Board layout	15
11	Abbreviations	16
12	References	16
13	Legal information	17
13.1	Definitions	17
13.2	Disclaimers	17
13.3	Trademarks	17
14	Contents	18

Please be aware that important notices concerning this document and the product(s) described herein, have been included in section 'Legal information'.

© NXP Semiconductors N.V. 2014. All rights reserved.

For more information, please visit: <http://www.nxp.com>
 For sales office addresses, please send an email to: salesaddresses@nxp.com

Date of release: 3 November 2014
 Document identifier: UM10791

X-ON Electronics

Largest Supplier of Electrical and Electronic Components

Click to view similar products for [LED Lighting Development Tools](#) category:

Click to view products by [NXP](#) manufacturer:

Other Similar products are found below :

[MIC2870YFT EV](#) [ADP8860DBCP-EVALZ](#) [LM3404MREVAL](#) [ADM8843EB-EVALZ](#) [TDGL014](#) [ISL97682IRTZEVALZ](#) [LM3508TLEV](#)
[EA6358NH](#) [MAX16826EVKIT](#) [MAX16839EVKIT+](#) [TPS92315EVM-516](#) [MAX6956EVKIT+](#) [OM13321,598](#) [DC986A](#) [DC909A](#) [DC824A](#)
[STEVAL-LLL006V1](#) [IS31LT3948-GRLS4-EB](#) [104PW03F](#) [PIM526](#) [PIM527](#) [MAX6946EVKIT+](#) [MAX20070EVKIT#](#) [MAX21610EVKIT#](#)
[MAX6951EVKIT](#) [MAX20090BEVKIT#](#) [MAX20092EVSYS#](#) [PIM498](#) [AP8800EV1](#) [ZXLD1370/1EV4](#) [MAX6964EVKIT](#) [TLC59116EVM-](#)
[390](#) [1216.1013](#) [TPS61176EVM-566](#) [TPS61197EVM](#) [TPS92001EVM-628](#) [1270](#) [1271.2004](#) [1272.1030](#) [1273.1010](#) [1278.1010](#) [1279.1002](#)
[1279.1001](#) [1282.1000](#) [1293.1900](#) [1293.1800](#) [1293.1700](#) [1293.1500](#) [1293.1100](#) [1282.1400](#)