

# QorIQ T1 and T2 Families of Communications Processors

Built for speed,  
designed to connect



# QorIQ T1 and T2 Families of Communications Processors

## Overview

The QorIQ communications portfolio delivers a smarter approach to multicore—providing a coherent migration path from single core to multicore and from 32-bit to 64-bit devices. Now over 25 products strong, the QorIQ communications platform is the industry’s broadest portfolio of communications processors, which enable customers to address opportunities and deploy their solutions across a wide range of performance, energy dissipation and cost points from power-constrained devices to the highest performance multicore devices. While the QorIQ communications portfolio has been widely deployed in a large number of networking segment applications, these high-performance, system-on-chip (SoC) solutions are consistently being adopted by industrial markets, as well.

The QorIQ T1 family of communications processors combines up to four 64-bit cores, built on Power Architecture® technology, with high-performance Data Path Acceleration Architecture (DPAA) and network peripheral bus interfaces required for networking and telecommunications. This scalable, pin-compatible family also features the industry’s first 64-bit embedded processor with an integrated Gigabit Ethernet switch (T1040 and T1020 processors) which simplifies hardware design, reduces power and overall system cost. The T1 family is ideally suited for use in mixed control and data plane applications such as fixed routers, switches, Internet access devices, firewall and other packet filtering applications,

as well as general-purpose embedded computing. Its high level of integration offers significant performance benefits and greatly helps to simplify board design.

The QorIQ T2080 and T2081 communications processors are primarily intended as a migration path from Freescale’s successful P3041 and P2041 mid-range series of quad-core devices in applications requiring control plane or integrated control and data plane processing. It provides an excellent migration path as it offers 2x or better core capability, increased cache sizes and additional Ethernet connectivity within a similar power budget. It also provides a value-engineering opportunity for P4080 communications processor customers, as T2080 device provides equivalent performance at much lower price and power. The T2080 communications processor is targeted at high-performance control plane applications or mid-range mixed control and data plane applications. The efficient e6500 core achieves up to 1.8 GHz, while maintaining a short seven-stage pipeline for better latency response to unpredictable control plane code branches. Advanced virtualization technology facilitates safe partitioning of control and data plane applications within the device. In addition, each e6500 core implements the Freescale Altivec technology SIMD engine, dramatically boosting the performance of media and networking algorithms without using additional DSP components on the board.

## QorIQ T1/T2 Families’ Features and Benefits

Key Features	Benefits
64-bit Built on Power Architecture Core	<ul style="list-style-type: none"> <li>Up to four cores at 1.4 GHz (T1040/T1042) and up to eight cores at 1.8 GHz on T2080/T2081</li> <li>Improved core architecture yields up to 6 DMIPS/MHz on T2 family dual-threaded processor and 3 DMIPS/MHz on T1 family of devices</li> <li>Up to 64 GB of addressable memory space</li> <li>T series platforms offer pin compatibility from dual to octal cores ranging from 1.2 to 1.8 GHz</li> </ul>
Energy Efficiency	<ul style="list-style-type: none"> <li>Power management with support for deep sleep to enable low power to convection cooled and energy-efficient green designs</li> <li>Compliant with energy management standards such as European Code of Conduct, EnergyStar and ECMA393</li> <li>Increase system power efficiency by 2x using advanced 28 nm process technology and energy efficiency with cascading power management</li> <li>Supports ½ watt AC</li> </ul>
Application-Specific Accelerators	<ul style="list-style-type: none"> <li>Increase system productivity with advanced core and SoC virtualization hardware and virtualization software solutions</li> <li>Simplify I/O virtualization with I/O MMU for access to memory sharing</li> <li>Support for Topaz, KVM and Linux® containers to meet customers demand</li> </ul>
Advanced Integration	<ul style="list-style-type: none"> <li>T1040/T1020 has an integrated Gigabit Ethernet switch to reduce system complexity and overall power</li> <li>Integrated accelerators, including DPAA—Classification, Traffic Management Pattern Matching and Security Engine</li> </ul>
Altivec Technology	<ul style="list-style-type: none"> <li>Deliver DSP functionality for compute-intensive processing tasks such as radar, sonar and image processing</li> <li>10x performance improvements with Altivec technology</li> <li>250+ Mentor Graphics Altivec libraries</li> </ul>
Trust Architecture	<ul style="list-style-type: none"> <li>Ensure only trusted code is booted</li> <li>Identify if the system is being tampered with and take appropriate action</li> <li>Protect secrets and intellectual property in the form of software</li> </ul>
Complete Solutions	<ul style="list-style-type: none"> <li>Complete development environment, including reference design boards, a software development kit, multicore debug and optimization tools and third-party production hardware and software solutions to enable you to design, develop and deliver your next solution to the market</li> </ul>

# Enterprise Equipment

Freescale is a long-standing leader in providing best-in-class solutions across the full range of networked enterprise applications, from SMB to large enterprises. Having served this market from the beginning, we understand that quality, scalability and security are of primary importance. Today's enterprise markets are migrating to public and hybrid models. In this evolving market, the ability to provide cloud-based expansion and services on demand as well as comprehensive, easy-to-use, management interfaces is also key. With the industry's broadest, most scalable portfolio of communications processors, our QorIQ communications processors form the basis of the intelligent network's infrastructure. These product families continue to deliver key architectural features such as security and connectivity, while also providing next-generation datapath, multicore architectures and commercial-grade, application-optimized VortiQa software for the next wave of enterprise-class solutions.

To help meet today's demanding requirements, enterprise equipment solutions must provide greater intelligence, higher bandwidth, wide connectivity, hardware-accelerated solutions and faster time to market. The QorIQ T1 and T2 families integrate the features and performance required to meet the needs of enterprise equipment and datacenter applications, including DPAA to offload packet processing, a highly efficient 64-bit core that is based on Power Architecture technology, ultimately providing the processing horsepower for compute-intensive and power conscious applications. In addition, the T1 and T2 families' massive integration significantly reduces system BOM cost. These capabilities, with industry-leading performance power watt metrics, truly deliver the best-in-class solution for the enterprise equipment market.

### Applications

- Branch office/SMB routers
- Ethernet switches
- UTM equipment
- Enterprise storage
- Data center

### Features for the Market

- Up to four e5500 cores provide up to 64 GB of memory critical for large routing tables
- Efficient cores: 3 DMIPs/MHz and 6 DMIPs/MHz means less processor to get the work done
- Integrated Gigabit Ethernet switch to reduce system complexity and overall power
- Four PCIe controllers for high-speed interconnect to routing ASICs
- Dual SATA ports provide high-speed, cost-effective storage options for statistics or large databases
- SEC and PME for value-added services
- x2 USB with PHY integrated for future expansion
- Trusted boot for IP protection



**Figure 1. Security Appliance/UTM Equipment Block Diagram**

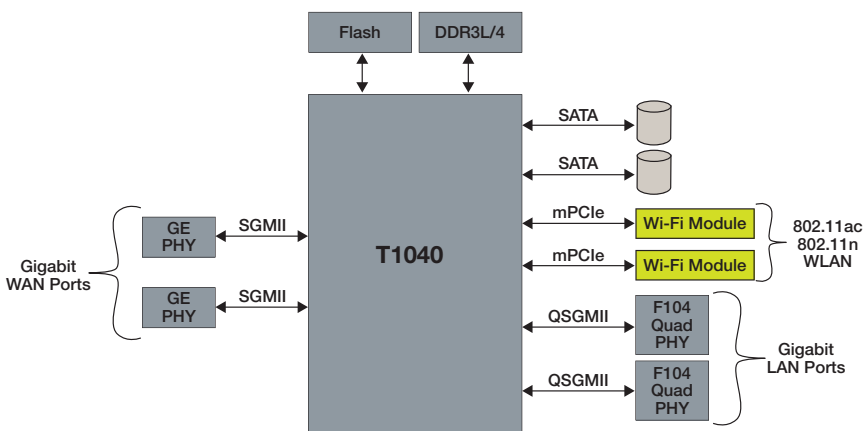

# Wireless Infrastructure

Telecommunications is undergoing extensive change as media convergence, industry consolidation, Internet and IP technologies and mobile communications come together. Freescale is leading innovation in next-generation networking infrastructure and mobile networks. With devices based on Power Architecture technology in the QorIQ processing platforms portfolio, StarCore-based DSPs and RF devices, our networking portfolio is unmatched in breadth. Combined with our enablement ecosystem and Freescale Connect partners, we can help you build full system solutions to accelerate your network's IQ. With the convergence and evolution of the wireless infrastructure market, vendors are seeking solutions that will enable them to support increased interworking and evolution of protocols to minimize market risks. Our industry-leading QorIQ communication platforms solve the interface, performance, security and protocol requirements posed by the wireless infrastructure market.

Freescale's investment in performance-optimized, form-factor-complete reference designs provides a starting point for customer development needs, accelerating time to market while significantly reducing overall development costs. These systems demonstrate how a high-performance CPU provides the complete data and control path processing needs for wireless infrastructure solutions while providing excellent throughput with best-in-class performance/watt.

The QorIQ T2080 communications processor is a particularly good fit as a 20 Gb/s network interface card (NIC), providing dual 10 GbE ports complemented by three DMA controllers capable of reading and writing 20 Gb/s over a x8 Gen 2.0 or a x4 Gen 3.0 PCI Express® port. In addition, the T2080 communications processor supports essential characteristics that fit right into the NIC applications, such as full endpoint configurability to allow driver code store and customization and accelerators support of IPsec, Kasumi, pattern matching and compression/decompression for various types of PCI Express services cards.

### Applications

- Mobile backhaul
- Network interface cards
- Channel cards
- Control cards in LTE, WCDMA, GSM, WiMAX

### Features for the Market

- Data Path Acceleration Architecture offers encryption acceleration for both wireless and IP networking protocols
- Accelerators support for IPsec, Kasumi, pattern matching and compression/decompression
- Multiple virtual CPUs may be dedicated to data path processing in each direction (wireless and IP)
- SR-IOV and I/O virtualization with DMA memory protection through IOMMUs and configurable "storage profiles"
- Cascading power management feature that brings cores from drowsy state to active state and back again based on networking workload
- Integrated SerDes reduces system interconnection costs

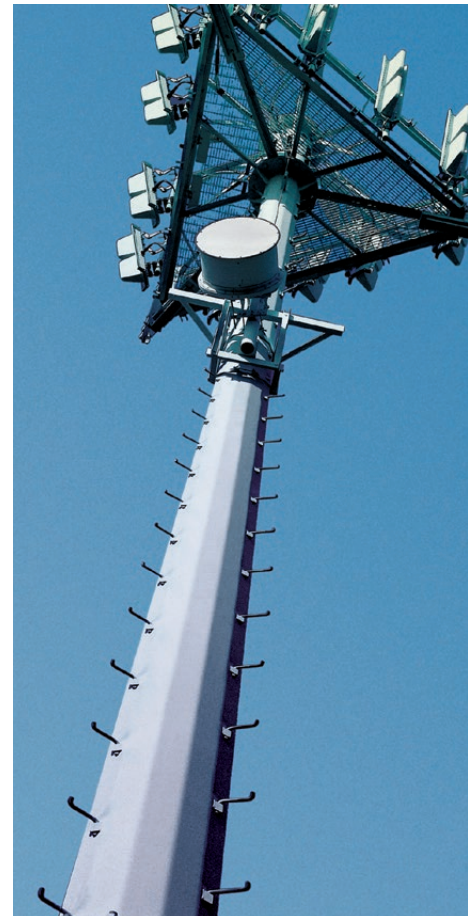

- Up to four x 10 Gb/s Ethernet MACs for high-speed network connections
- PCIe Gen3 and Gen2 controllers for direct interaction with Network Interface Cards

**Figure 2. Smart 20 Gb/s Network Interface Card Block Diagram**

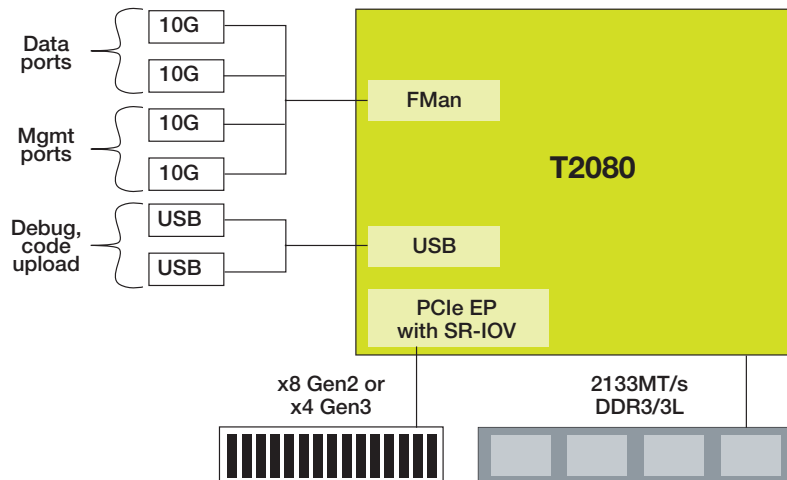

## Industrial

In today's industrial market, new technology provides many opportunities for system developers to successfully address ever-evolving challenges. Freescale control and network processor solutions are engineered to meet the challenging safety, security and reliability requirements of manufacturing, processing and critical infrastructure facilities. With an industry-leading quality and reliability foundation, vast resources for development and innovation and strategic alliances, Freescale is fulfilling customers' needs to meet the growing requirements for more intelligent and cost-effective industrial solutions for the industrial control and networking, defense and aerospace, power protection and factory automation markets. Freescale delivers embedded industrial solutions engineered to meet the environmental, longevity and energy efficiency requirements of connected industrial applications.

## Aerospace and Defense

Next-generation aerospace and defense (A&D) systems have a broad spectrum of requirement with a common thread—increased processing requirements for safety and security. For the aerospace market, QorIQ family of communications processors meets the performance, safety and security criteria mandated by the aerospace and defense applications. Freescale's T2 family of communications processors deliver highly integrated solutions that combine high-speed I/O, multiple memory controllers and secure boot options as well as a sophisticated security engine to help designers reduce space, weight and power while ensuring security within their application.

Aerospace and defense applications need power-efficient SIMD performance, as well as fast signal processing, image processing and math operations such as matrix multiplication. QorIQ T2080's AltiVec technology provides general-purpose processing, data processing, IEEE® standard floating-point and digital signal processing (DSP) on a single monolithic silicon substrate, enabling the aerospace and defense

embedded computing designers to use a SIMD engine within a multicore processor.

Freescale has a longstanding track record of providing long-term production support for our products. Freescale is pleased to provide a formal Product Longevity Program for all market segments in which Freescale participates by making a broad range of devices available. Freescale is committed to continue technology advancements, providing cost-effective, reliable, field-proven solutions for the defense and commercial aerospace markets.

### Applications

- Ruggedized (or highly secure) routers
- Instrumentation panels
- Avionics networking
- Single-board computers
- Factory automation
- Data collection cards

### Features for the Market

- High-frequency dual-threaded, 7-stage pipeline, a tightly coupled cache hierarchy for low latency and integrated hardware acceleration processors for compute intensive, power-conscious applications
- 64-bit ISA support to increase performance for computational-intensive applications with large data sets

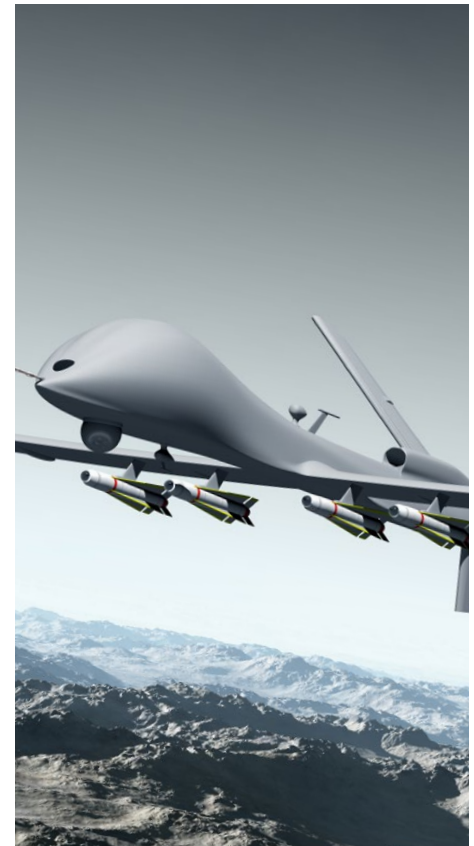

- Broad range of third-party embedded OS supported
- Security engine to perform high throughput encryption/decryption
- AltiVec technology 128-bit SIMD engine for boosting the performance of media and networking algorithms
- Long product life cycles
- Hypervisor support for safe partitioning of control and data plane

**Figure 3. Industrial Single-Board Computer Block Diagram**

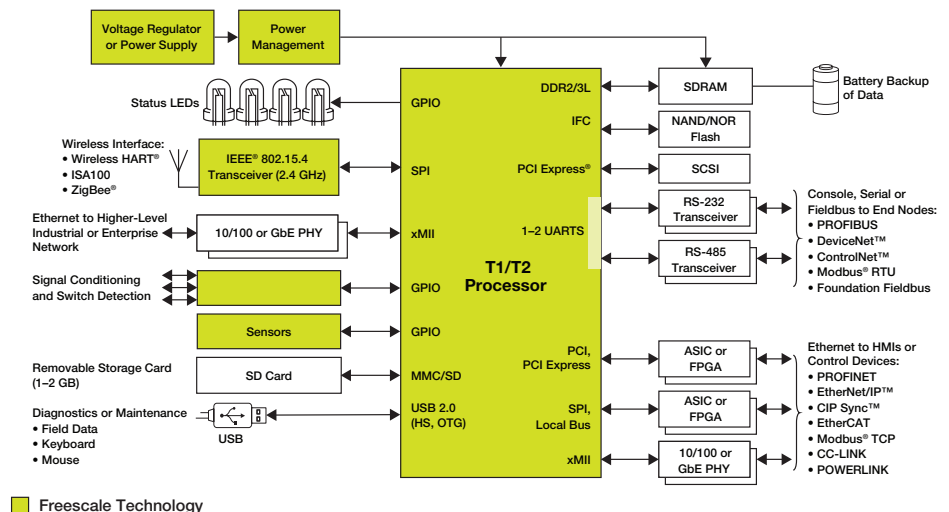



## Service Provider

In addition to the challenges service providers face with the exponential growth in consumer demand for bandwidth, they are also increasingly interested in knowing more about the user so that they can provide more tailored services. Both of these trends are driving new technologies such as LTE as well as a new infrastructure that is faster, smarter and more elastic in its use of resources. Freescale is one of the few suppliers that offers a complete portfolio of products for this growing market. QorIQ communications processors provide the infrastructure support and intelligence (application identification, virtualization, SDN) for optimized networking. In addition, the QorIQ communications platforms are supported by VortiQa software, which offers production-ready software, accelerating time to market.

Connecting to the IP network offers the service provider market tremendous cost savings, but introduces all the security threats found in the IP world. The QorIQ T1 and T2 families and their peripheral interfaces provide the flexibility to connect to DSPs and to wireless link layer framing ASICs/FPGAs. While DPAA offers encryption acceleration for both wireless and IP networking protocols, in

addition to packet filtering capability on the IP networking side, multiple virtual CPUs may be dedicated to data path processing in each direction. Combined with our enablement ecosystem and Freescale partners, we can help you build full system solutions to accelerate your network's IQ.

### Applications

- Access routers
- Broadband access
- Metro Ethernet
- Optical networking

### Features for the Market

- Integrated Gigabit Ethernet switch to reduce system BOM cost
- DPAA offers encryption acceleration for both wireless and IP networking protocols
- Packet filtering capability on the IP networking side
- Support of DDR3L/DDR4 memory
- Hardware virtualization provides safe and autonomous operation of multiple individual operating systems

**Figure 4. Secure Gateway Block Diagram**

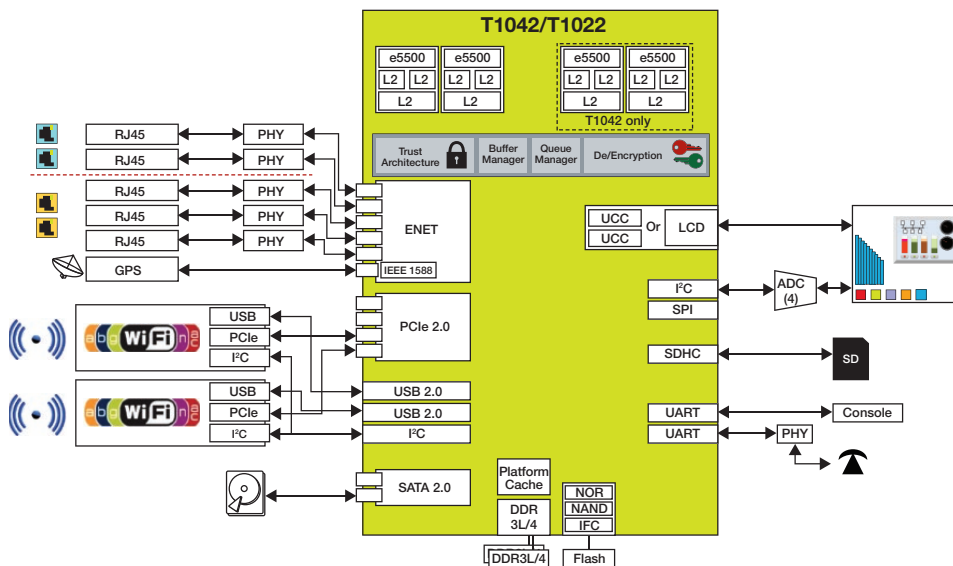

## QorIQ Processing Platforms

	T1040/T1020	T1042/T1022	T2081	T2080
<b>CPU Frequency Range</b>	1200–1400 MHz	1200–1400 MHz	1500–1800 MHz	1200–1800 MHz
<b>Cores</b>	4/2	4/2	4	4
<b>Threads</b>	4//2	4/2	8	8
<b>DMIPS</b>	16,800/8,400	16,800/8,400	43,200	43,200
<b>Cache (I/D)</b>	32 K/32 K	32 K/32 K	32 K/32 K	32 K/32 K
<b>Cache L2</b>	256 KB/core	256 KB/core	2 MB Shared	2 MB Shared
<b>Cache L3</b>	256 KB	256 KB	512 KB	512 KB
<b>DDR Controller</b>	32-/64-bit DDR3L/4	32-/64-bit DDR3L/4	64-bit DDR3/3L	64-bit DDR3/3L
<b>DDR Data Rate (GHz)</b>	1.6 GHz	1.6 GHz	2.133 GHz	2.133 GHz
<b>PCI Express®</b>	4 Gen 2.0	4 Gen 2.0	1 Gen 3.0, 3 Gen 2.0	1 Gen 3.0, 3 Gen 2.0
<b>USB 2.0</b>	2	2	2	2
<b>SATA</b>	2	2	N/A	2
<b>SRIO</b>	N/A	N/A	N/A	2 + RMan
<b>GbE</b>	Up to 4 x GbE, 8-port Gigabit Ethernet Switch	Up to 5 x GbE	Up to 7 x GbE, Up to 2 x 10GbE	Up to 8 x GbE, Up to 4 x 10GbE
<b>SerDes</b>	8 lanes @ 5 Gb/s	8 lanes @ 5 Gb/s	8 lanes @ 10 Gb/s	16 lanes @ 10 Gb/s
<b>FPU</b>	Double precision	Double precision	Double precision	Double precision
<b>Accelerators</b>	DPAA, PME, SEC 5.x with Trust Architecture	DPAA, PME, SEC 5.x with Trust Architecture	DPAA, PME, DCE, SEC 5.x with Trust Architecture	DPAA, PME, DCE, RMan, SEC 5.x with Trust Architecture
<b>Package</b>	780 FCPBGA	780 FCPBGA	780 FCPBGA	896 FCPBGA
<b>Process Technology</b>	TSMC 28HPM	TSMC 28HPM	TSMC 28HPM	TSMC 28HPM
<b>Estimated Typical Power</b>	~5.26 W/~4.16 W	~5.13 W/~4.03 W	~14 W	~14.9 W
<b>Other Features</b>	eSPI, 2 x I <sup>2</sup> C, 4 x UART, CoreNet, QUICC Engine, SD/MMC, DMA, Hardware Hypervisor, IFC, DIU	eSPI, 2 x I <sup>2</sup> C, 4 x UART, CoreNet, QUICC Engine, SD/MMC, DMA, Hardware Hypervisor, IFC, DIU	eSPI, 4 x I <sup>2</sup> C, 4 x UART, CoreNet, SD/MMC, DMA, Hardware Hypervisor, IFC, Trust Architecture, Altivec	eSPI, 4 x I <sup>2</sup> C, 4 x UART, CoreNet, SD/MMC, DMA, Hardware Hypervisor, IFC, Trust Architecture, Altivec

For more information, please visit [freescale.com/QorIQ](http://freescale.com/QorIQ)

Freescale, the Freescale logo, Altivec, QorIQ, StarCore and VortiQa are trademarks of Freescale Semiconductor, Inc., Reg. U.S. Pat. & Tm. Off. All other product or service names are the property of their respective owners. The Power Architecture and Power.org word marks and the Power and Power.org logos and related marks are trademarks and service marks licensed by Power.org.  
© 2014 Freescale Semiconductor, Inc.

Document Number: BRT1T2FAM REV 0

## X-ON Electronics

Largest Supplier of Electrical and Electronic Components

*Click to view similar products for [Development Boards & Kits - Other Processors](#) category:*

*Click to view products by [NXP](#) manufacturer:*

Other Similar products are found below :

[EVB-MEC1418MECC](#) [20-101-1252](#) [C29XPCIE-RDB](#) [CC-ACC-18M433](#) [STM8S/32-D/RAIS](#) [MAX1464EVKIT](#) [RTK0EN0001D01001BZ](#)  
[MAXQ622-KIT#](#) [YR0K50571MS000BE](#) [QB-R5F104PJ-TB](#) [CC-ACC-ETHMX](#) [OV-7604-C7-EVALUATION-BOARD](#) [SK-AD02-](#)  
[D62Q1747TB](#) [SK-BS01-D62Q1577TB](#) [ST7MDT1-EMU2](#) [GROVE BASE KIT FOR RASPBERRY PI](#) [CY8CKIT-143A](#) [EK-MPC5744P](#)  
[KITAURIXTC234TFTTOBO1](#) [ENW89854AXKF](#) [ENWF9201AVEF](#) [QB-R5F104LE-TB](#) [LV18F V6 64-80-PIN TQFP MCU CARD EMPTY](#)  
[LV-24-33 V6 44-PIN TQFP MCU CARD EMPTY](#) [LV-24-33 V6 64-PIN TQFP MCU CARD EMPTY](#) [LV-24-33 V6 80-PIN TQFP 1 MCU](#)  
[CARD EMPTY](#) [32X32 RGB LED MATRIX PANEL - 6MM PITCH](#) [3.3 - 5 VTRANSLATOR](#) [READY FOR XMEGA CASING \(WHITE\)](#)  
[RELAY4 BOARD](#) [ETHERNET CONNECTOR](#) [RFID CARD 125KHZ - TAG](#) [RFID READER](#) [RFM12B-DEMO](#) [MAROON](#) [3G CLICK](#)  
[\(FOR EUROPE AND AUSTRALIA\)](#) [MAX232](#) [MAX3232 BOARD](#) [ARTY S7-50](#) [TINKERKIT HALL SENSOR](#) [TOUCHPANEL](#)  
[TOUCHPANEL CONTROLLER](#) [MIKROBOARD FOR AVR WITH ATMEGA128](#) [MIKROBOARD FOR PSOC WITH CY8C27643](#)  
[MIKROBUS CAPE](#) [MIKRODRIVE](#) [MIKROETH 100 BOARD](#) [MIKROLAB FOR 8051 L](#) [MIKROPROG TO ST-LINK V2 ADAPTER](#)  
[BANANA PI GPIO EXTEND MODULE](#)