



TEA1999TS/2

GreenChip synchronous rectifier controller

Rev. 1 — 12 September 2018

Product data sheet

1 General description

The TEA1999TS is a member of a new generation of Synchronous Rectifier (SR) controller ICs for switched mode power supplies with adaptive gate drive for maximum efficiency at any load.

The TEA1999TS is a dedicated controller IC for synchronous rectification on the secondary side of flyback converters. It incorporates the sensing stage and driver stage for driving the SR MOSFET, which is rectifying the output of the secondary transformer winding.

The TEA1999TS can generate its own supply voltage for battery charging applications with low output voltage or for applications with high-side rectification.

The TEA1999TS is fabricated in a Silicon-On-Insulator (SOI) process.

2 Features and benefits

2.1 Efficiency features

- Adaptive gate drive for maximum efficiency at any load
- Typical supply current in no-load operation below 250 μ A

2.2 Application features

- Operates in an output voltage range between 26 V and 0 V
- Drain sense pin capable of handling input voltages up to 120 V
- Self-supplying for operation with low output voltage
- Self-supplying for high-side rectification without the use of an auxiliary winding
- Operates with standard and logic level SR MOSFETs
- Supports USB BC, QuickCharge, and smart charging applications
- TSOP6 package

2.3 Control features

- Adaptive gate drive for fast turn-off at the end of conduction
- UnderVoltage LockOut (UVLO) with active gate pull-down



3 Applications

The TEA1999TS is intended for flyback power supplies. In such applications, it can drive the external synchronous rectifier MOSFET, which replaces the diode for the rectification of the voltage on the secondary winding of the transformer.

It can be used in all power supplies that require a high efficiency, like:

- Chargers
- Adapters
- Flyback power supplies with very low and/or variable output voltage

4 Ordering information

Table 1. Ordering information

Type number	Package		
	Name	Description	Version
TEA1999TS/2	TSOP6	plastic surface-mounted package (TSOP6); 6 leads	SOT457

5 Marking

Table 2. Marking code

Type number	Marking code
TEA1999TS/2	TEA1999

6 Block diagram

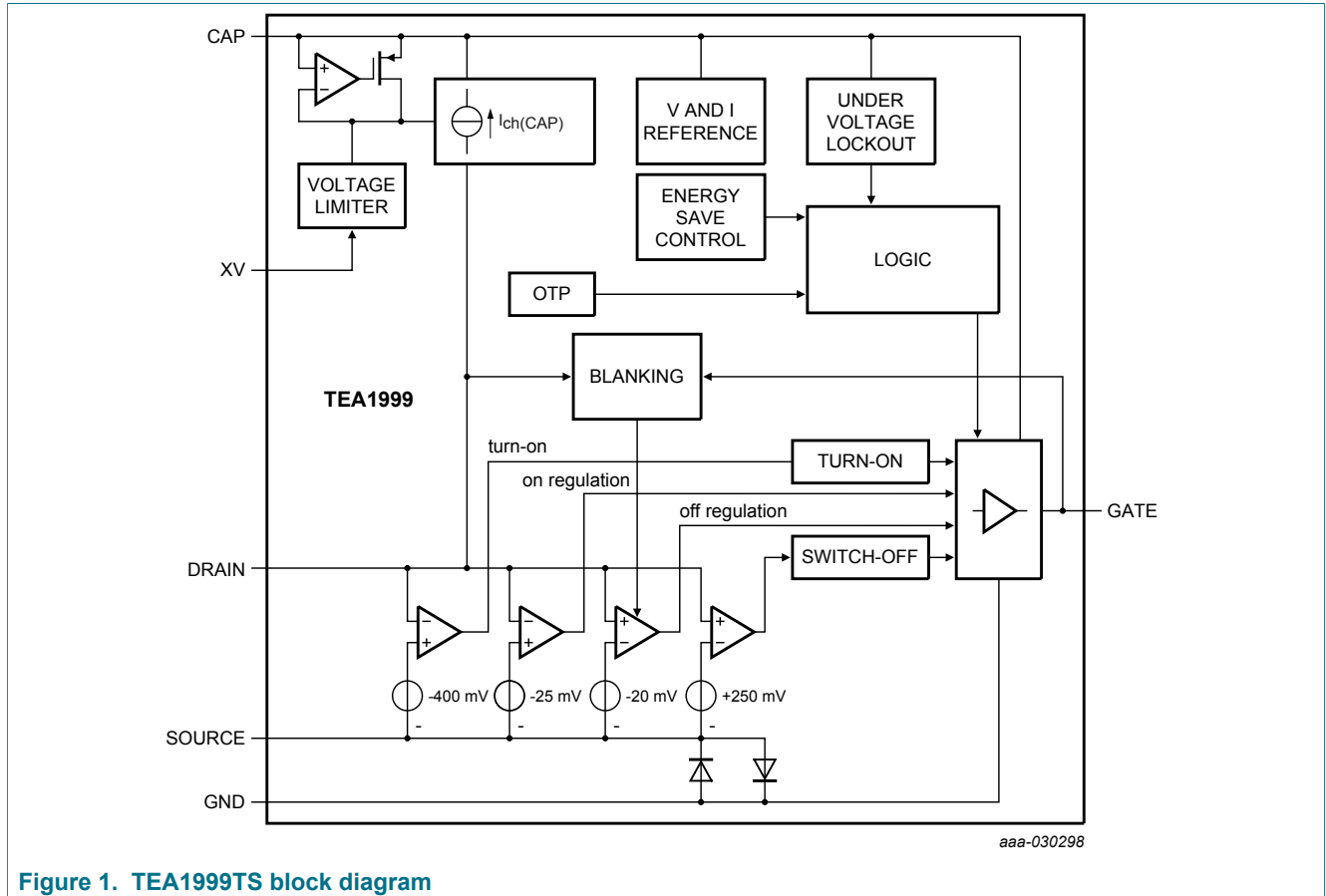

Figure 1. TEA1999TS block diagram

7 Pinning information

7.1 Pinning

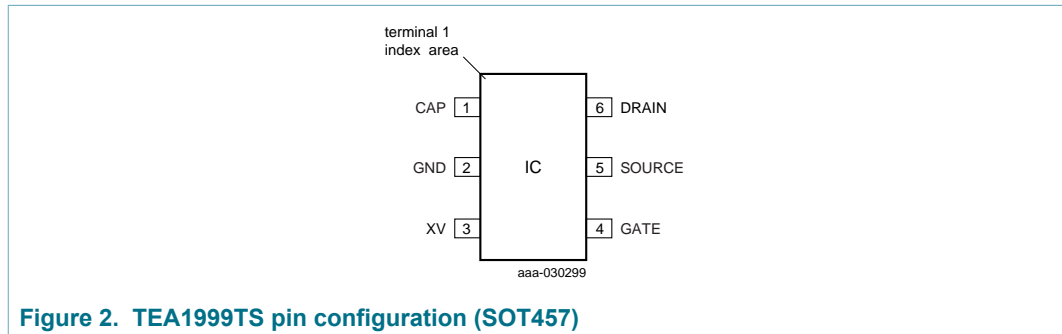

Figure 2. TEA1999TS pin configuration (SOT457)

7.2 Pin description

Table 3. Pin description

Symbol	Pin	Description
CAP	1	capacitor input for internal supply voltage
GND	2	ground
XV	3	external supply input
GATE	4	gate driver output for SR MOSFET
SOURCE	5	source sense input of SR MOSFET
DRAIN	6	drain sense input of SR MOSFET

8 Functional description

8.1 Introduction

The TEA1999TS is a controller IC for Synchronous Rectification (SR) in flyback applications. It can drive the external synchronous rectifier MOSFET for the rectification of the voltage on the secondary winding of the transformer. Figure 3 shows a typical configuration.

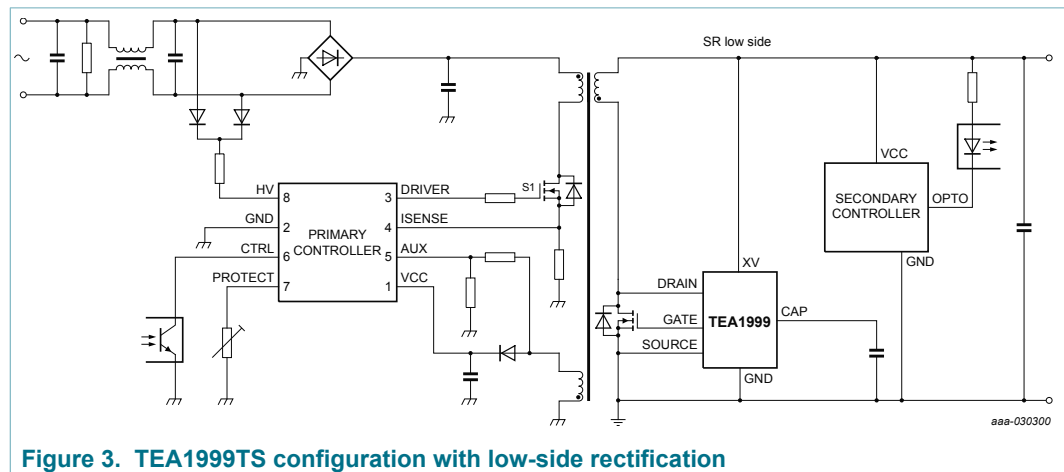

Figure 3. TEA1999TS configuration with low-side rectification

8.2 Start-up and UnderVoltage LockOut (UVLO; CAP and XV pins)

The capacitor on the CAP pin supplies the TEA1999TS. At a low CAP voltage ($< 3.7\text{ V}$), the capacitor is charged via the DRAIN pin with a limited start-up current of typically 15 mA. When the CAP voltage exceeds 3.7 V, the DRAIN pin or the XV pin can charge the capacitor. When the XV voltage $< 4.7\text{ V}$, the capacitor is charged via the DRAIN pin with a typical charge current of 125 mA. When the XV voltage $\geq 4.7\text{ V}$, the capacitor is charged via the XV pin and an internal regulator. The regulator reduces the voltage difference between the XV and CAP pins to a level below 100 mV.

When the voltage on the CAP pin exceeds $V_{\text{start(CAP)}}$ (3.7 V typical), the IC leaves the UVLO state and activates the synchronous rectifier circuitry. When the voltage drops below 3.6 V (typical), the UVLO state is reentered and the SR MOSFET gate driver output is actively kept low.

8.3 Drain sense (DRAIN pin)

The drain sense pin is an input pin capable of handling input voltages up to 120 V. At positive drain sense voltages, the gate driver is in off-mode with the gate driver pulled down (pin GATE). At negative drain sense voltages, the IC enables the Synchronous Rectification (SR) by sensing the drain source differential voltage.

8.4 Synchronous rectification (DRAIN and SOURCE pins)

The IC senses the voltage difference between the drain sense (DRAIN pin) and the source sense (SOURCE pin) connections. This drain source differential voltage of the SR MOSFET is used to drive the gate of the SR MOSFET.

When this absolute voltage difference is higher than $V_{act(drv)}$, the corresponding gate driver output turns on the external SR MOSFET. When the external SR MOSFET is switched on, the absolute voltage difference between the drain and the source sense connections drops to below $V_{act(drv)}$. The regulation phase follows the turn-on phase.

In the regulation phase, the IC regulates the difference between the drain and the source sense inputs to an absolute level of 25 mV. When the absolute difference exceeds 25 mV ($V_{reg(drv)}$), the gate driver output increases the gate voltage of the external SR MOSFET until the 25 mV level is reached. The SR MOSFET does not switch off at low current. To avoid that the device switches off because of ringing, a minimum on-time of 1.5 μs ($t_{act(sr)}$ _(min)) is integrated.

When the absolute difference < 20 mV, the gate driver output decreases the gate voltage of the external SR MOSFET. The voltage waveform on the gate of the SR MOSFET follows the waveform of the current through the SR MOSFET. When the current through the SR MOSFET reaches zero, the SR MOSFET is switched off quickly.

After SR MOSFET switch-off, the drain voltage increases. When the drain voltage exceeds 250 mV, a low ohmic gate pull-down of 3 Ω keeps the gate of the SR MOSFET switched off.

8.5 Gate driver (GATE pin)

The gate driver circuit charges the gate of the external SR MOSFET during the rising part of the current. The driver circuit discharges the gate during the falling part of the current. The gate driver has a source capability of typically 0.70 A. It has a sink capability of typically 0.50 A. The source and sink capabilities allow fast turn-on and fast turn-off of the external SR MOSFET.

The maximum output voltage of the driver is limited to the voltage on the CAP pin. The maximum output voltage ranges between 4.7 V and 10 V, depending on the voltage on the CAP pin. The high output gate voltage drives all MOSFET brands to the minimum on-state resistance. In applications where the IC is supplied with 5 V, the maximum output voltage of the driver is 4.90 V, and logic level SR MOSFETs can be used.

The IC is self-supplying in applications with high-side rectification or in battery charging applications with an output voltage < 4.7 V. When the XV pin is connected to ground for driving standard SR MOSFETs, the driver is regulated to 10 V. When the XV pin is connected to the converter output for driving logic-level SR MOSFETs, the driver is regulated to the voltage on the XV pin with a minimum of 4.7 V.

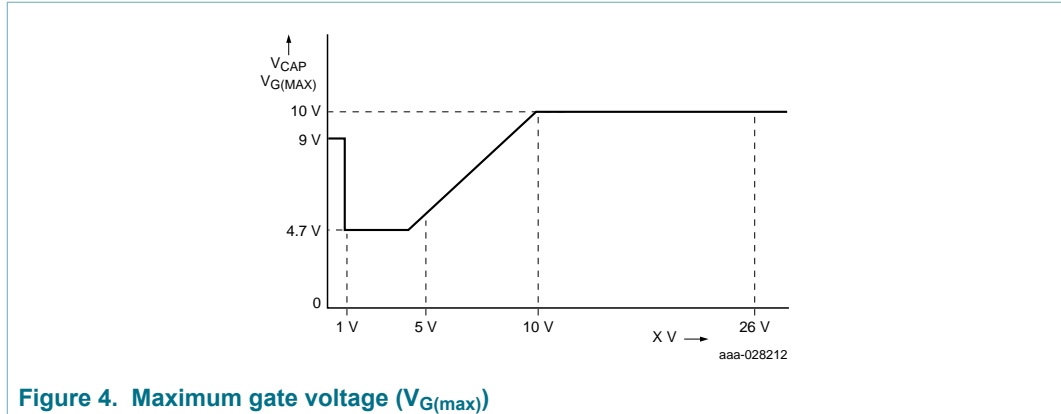

During start-up conditions ($V_{CAP} < V_{start(CAP)}$) and UVLO, the driver output voltage is actively pulled low.

When the X V voltage exceeds 10 V, the CAP voltage and $V_{G(max)}$ are limited to typically 10.7 V. The X V voltage is allowed to increase until the 26 V limit is reached.

8.6 Source sense (SOURCE pin)

The IC is equipped with an additional source sense pin (SOURCE). This pin is used for measuring the drain-to-source voltage of the external SR MOSFET. Voltage differences on PCB tracks because of parasitic inductance in combination with large di/dt values, can cause errors. To minimize these errors, the source sense input must be connected as close as possible to the SOURCE pin of the external SR MOSFET.

8.7 Overtemperature protection (GATE pin)

Overtemperature protection is triggered when the output of the gate driver:

- Has a load that is too high
- Is short-circuited to ground
- Is short-circuited to the SOURCE pin

The OTP circuit is triggered at 165 °C. It actively pulls down the gate driver output. When the temperature has decreased to 145 °C, the circuit resumes normal operation.

9 Limiting values

Table 4. Limiting values

In accordance with the Absolute Maximum Rating System (IEC 60134). All voltages are measured with respect to ground (pin 2); positive currents flow into the chip. Voltage ratings are valid provided other ratings are not violated; current ratings are valid provided the other ranges are not violated.

Symbol	Parameter	Conditions	Min	Max	Unit	
Voltages						
V_{XV}	voltage on pin XV		-0.4	+26	V	
$V_{sense(DRAIN)}$	sense voltage on pin DRAIN		-0.8	+120	V	
$V_{sense(SOURCE)}$	sense voltage on pin SOURCE		-0.4	+0.4	V	
General						
P_{tot}	total power dissipation	$T_{amb} = 90\text{ °C}$	-	300	mW	
T_{stg}	storage temperature		-55	+150	°C	
T_j	junction temperature		-40	+150	°C	
ElectroStatic Discharge (ESD)						
V_{ESD}	electrostatic discharge voltage	class 2				
		human body model	[1]	-	2000	V
		charged device model		-	500	V
		machine model	[2]	-	200	V

[1] Equivalent to discharging a 100 pF capacitor through a 1.5 kΩ series resistor.

[2] Equivalent to discharging a 200 pF capacitor through a 10 Ω series resistor and a 0.75 μH inductor.

10 Recommended operating conditions

Table 5. Recommended operating conditions

Symbol	Parameter	Conditions	Min	Typ	Max	Unit
V_{XV}	voltage on pin XV		0	-	21	V
V_{DRAIN}	voltage on pin DRAIN	peak voltage in switching application	8	-	120	V

11 Thermal characteristics

Table 6. Thermal characteristics

Symbol	Parameter	Conditions	Typ	Unit
$R_{th(j-a)}$	thermal resistance from junction to ambient	JEDEC test board	200	K/W
$R_{th(j-c)}$	thermal resistance from junction to case	JEDEC test board	115	K/W

12 Characteristics

Table 7. Characteristics

$-25\text{ }^{\circ}\text{C} < T_j < +125\text{ }^{\circ}\text{C}$; $V_{XV} = 5\text{ V}$; $C_{CAP} = 1\text{ }\mu\text{F}$; $C_{GATE} = 10\text{ nF}$ (capacitor between the GATE and the GND pins); all voltages are measured with respect to ground (pin 2); currents are positive when flowing into the IC; unless otherwise specified.

Symbol	Parameter	Conditions	Min	Typ	Max	Unit
Supply voltage management (XV and CAP pins)						
$V_{\text{start(CAP)}}$	start voltage on pin CAP	$V_{XV} = 0\text{ V}$	3.5	3.7	3.9	V
$V_{\text{stop(CAP)}}$	stop voltage on pin CAP	$V_{XV} = 0\text{ V}$	3.4	3.6	3.8	V
$I_{\text{start(CAP)}}$	start current on pin CAP	$V_{XV} = 5\text{ V}$; $V_{CAP} = 0\text{ V}$; $V_{DRAIN} = 12\text{ V}$	-24	-15	-8	mA
$I_{\text{ch(CAP)}}$	charge current on pin CAP	power save operation				
		$V_{XV} = 0\text{ V}$; $V_{CAP} = 8\text{ V}$; $V_{DRAIN} = 12\text{ V}$; $T_j = 25\text{ }^{\circ}\text{C}$	-120	-80	-50	mA
		$V_{XV} = 2\text{ V}$; $V_{CAP} = 4\text{ V}$; $V_{DRAIN} = 12\text{ V}$; $T_j = 25\text{ }^{\circ}\text{C}$	-160	-110	-50	mA
$V_{I(\text{CAP})}$	input voltage on pin CAP	$V_{XV} = 0\text{ V}$; $V_{DRAIN} = 15\text{ V}$	9.0	9.4	9.8	V
		$V_{XV} = 2\text{ V}$; $V_{DRAIN} = 12\text{ V}$	4.5	4.6	4.8	V
		$V_{XV} = 5\text{ V}$	4.8	4.9	5.0	V
		$V_{XV} = 10\text{ V}$	9.8	9.9	10.0	V
		$V_{XV} = 26\text{ V}$	10.3	10.7	11.1	V
$I_{I(\text{XV})}$	input current on pin XV	power save operation; $V_{DRAIN} = 5.5\text{ V}$; $T_j = 25\text{ }^{\circ}\text{C}$	200	240	280	μA
		normal operation; without gate charge; V_{DRAIN} step from 5.5 V to -250 mV; $T_j = 25\text{ }^{\circ}\text{C}$	1.0	1.2	1.4	mA
$t_{\text{act(pwrsave)}}$	power-save activation time		70	100	130	μs
Synchronous rectification sense input (DRAIN and SOURCE pins)						
$V_{\text{act(drv)}}$	driver activation voltage	$V_{\text{SOURCE}} = 0\text{ V}$; $T_j = 25\text{ }^{\circ}\text{C}$	-510	-470	-430	mV
$V_{\text{reg(drv)}}$	driver regulation voltage	$V_{\text{SOURCE}} = 0\text{ V}$; $T_j = 25\text{ }^{\circ}\text{C}$	-30	-25	-20	mV
V_{swoff}	switch-off voltage	$V_{\text{SOURCE}} = 0\text{ V}$	180	250	320	mV
$t_{\text{d(act)(drv)}}$	driver activation delay time	$V_{\text{SOURCE}} = 0\text{ V}$; normal operation; time for step-on V_{DRAIN} (2 V to -0.5 V) to rising of V_G at 10 % of end value	-	40	-	ns
$t_{\text{d(deact)(drv)}}$	driver deactivation delay time	$V_{\text{SOURCE}} = 0\text{ V}$; normal operation; time for step-on V_{DRAIN} (-50 mV to 2 V) to falling of V_G at 90 % of begin value	-	40	-	ns
$t_{\text{act(sr)(min)}}$	minimum synchronous rectification active time	$V_{\text{SOURCE}} = 0\text{ V}$; normal operation; time for step-on V_{DRAIN} (-700 mV to +100 mV) to falling of V_G at 90 % of begin value; without gate charge	1.1	1.4	1.8	μs

Symbol	Parameter	Conditions	Min	Typ	Max	Unit
Gate driver (GATE pin)						
I_{source}	source current	peak current; $V_{XV} = 5\text{ V}$; $V_{ds} = -0.5\text{ V}$; $V_G = 0\text{ V}$	-	-0.70	-	A
I_{sink}	sink current	regulation current; $V_{XV} = 5\text{ V}$; $V_{ds} = 0\text{ V}$; $V_G = 3\text{ V}$	-	100	-	mA
		peak current; $V_{XV} = 5\text{ V}$; $V_{ds} = 0.5\text{ V}$; $V_G = 4\text{ V}$	-	0.50	-	A
$R_{pd(G)}$	gate pull-down resistance	$V_{DRAIN} = 0.5\text{ V}$; $I_G = 100\text{ mA}$; $V_{XV} = 5\text{ V}$; $T_j = 25\text{ °C}$	2.6	3.2	4.0	Ω
$V_{G(max)}$	maximum gate voltage	$V_{XV} = 0\text{ V}$	9.0	9.4	9.8	V
		$V_{XV} = 2\text{ V}$	4.45	4.60	4.75	V
		$V_{XV} = 5\text{ V}$	4.8	4.9	5.0	V
		$V_{XV} = 10\text{ V}$	9.8	9.9	10.0	V
		$V_{XV} = 26\text{ V}$	10.3	10.7	11.1	V
Temperature protection						
$T_{otp(act)}$	activation overtemperature protection temperature		155	165	175	$^{\circ}\text{C}$
$T_{otp(hys)}$	overtemperature protection trip hysteresis		-	20	-	$^{\circ}\text{C}$

12.1 Temperature curves

12.1.1 Charge current (CAP pin)

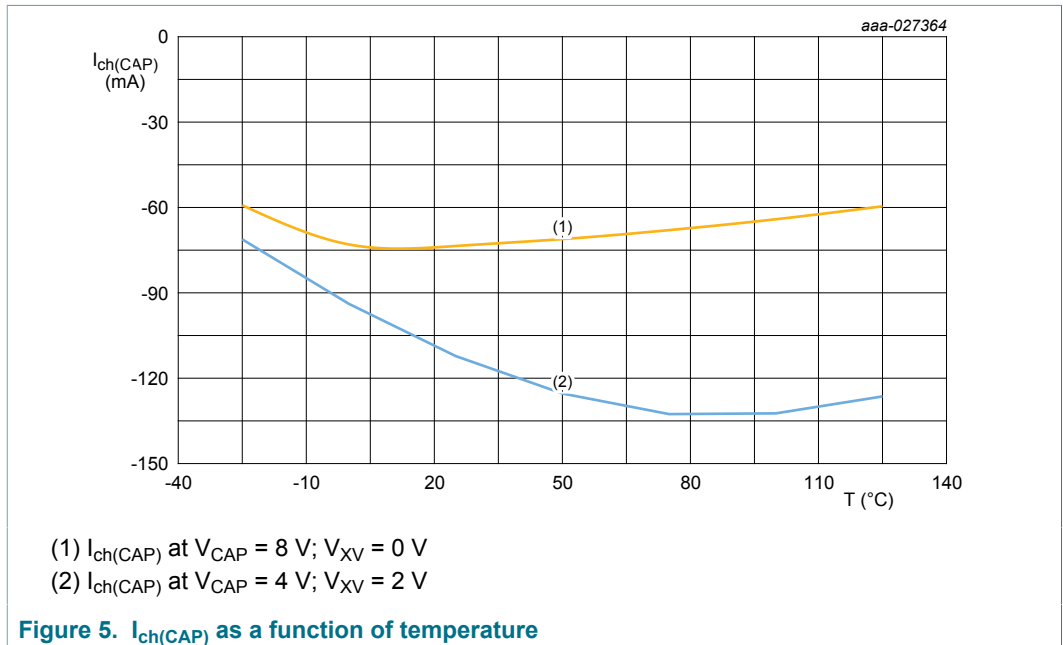

12.1.2 Operating current (XV pin)

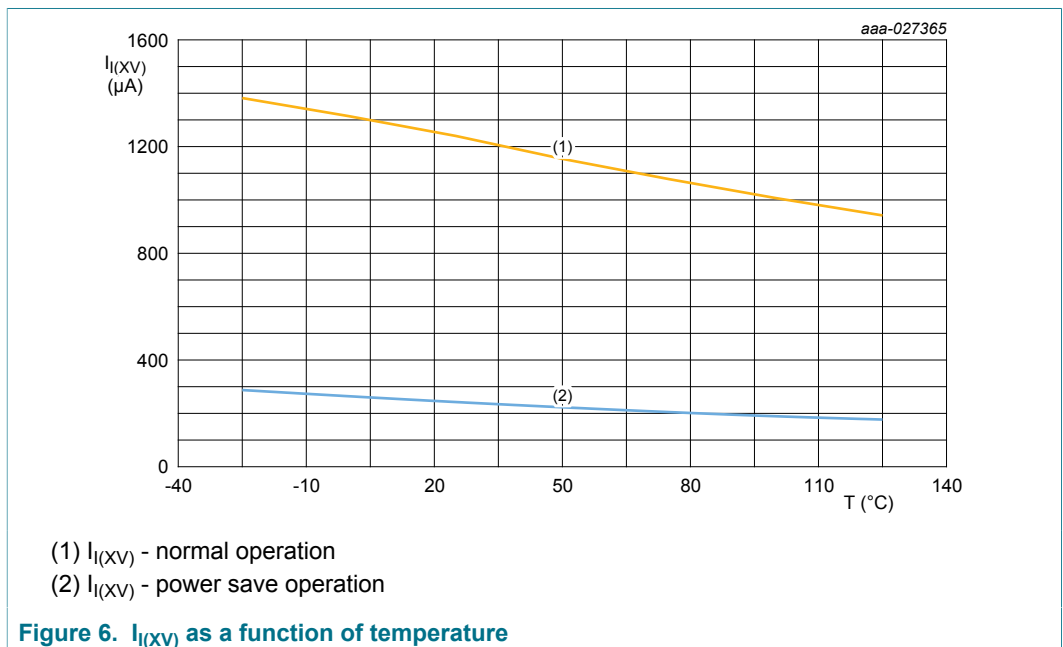

12.1.3 Driver regulation voltage

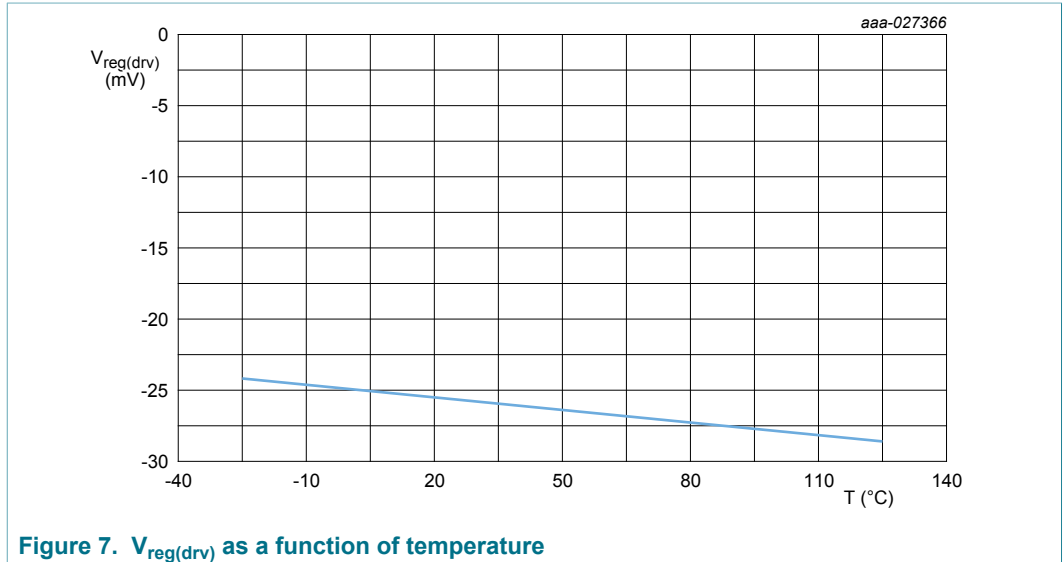

12.1.4 Gate pull-down resistance

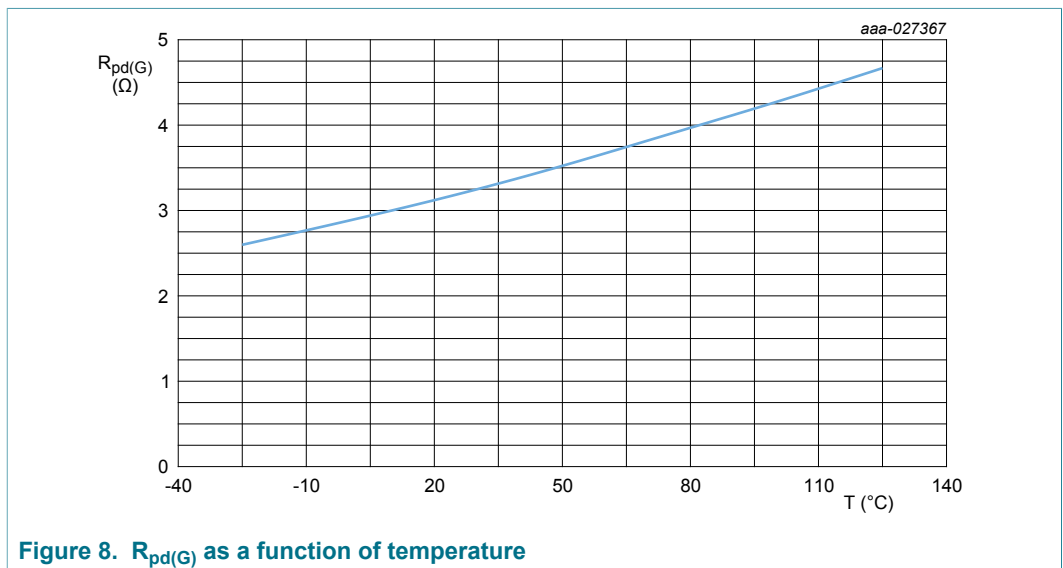

12.1.5 Switch-off voltage

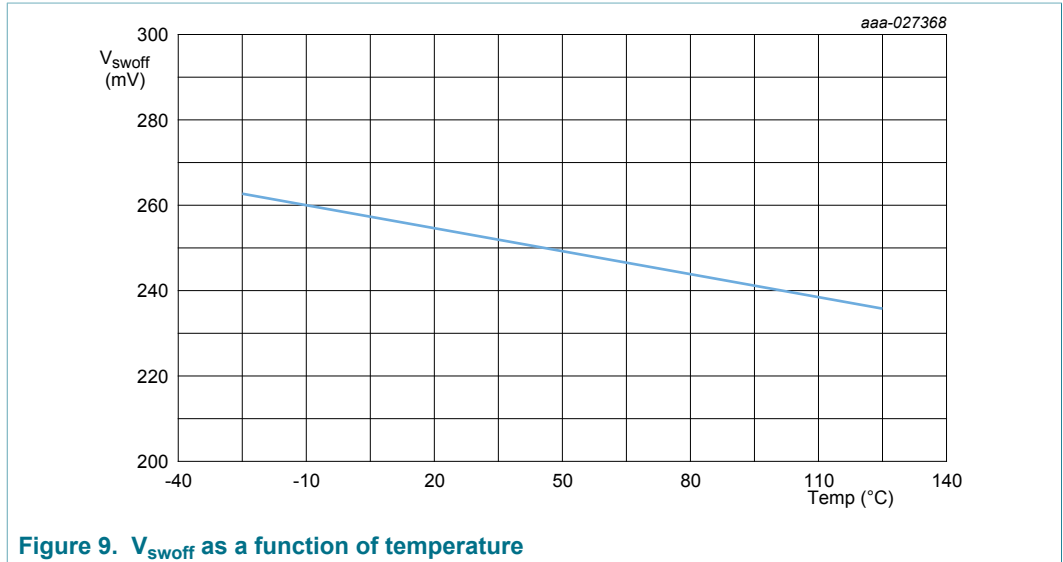

12.1.6 Minimum synchronous rectification active time

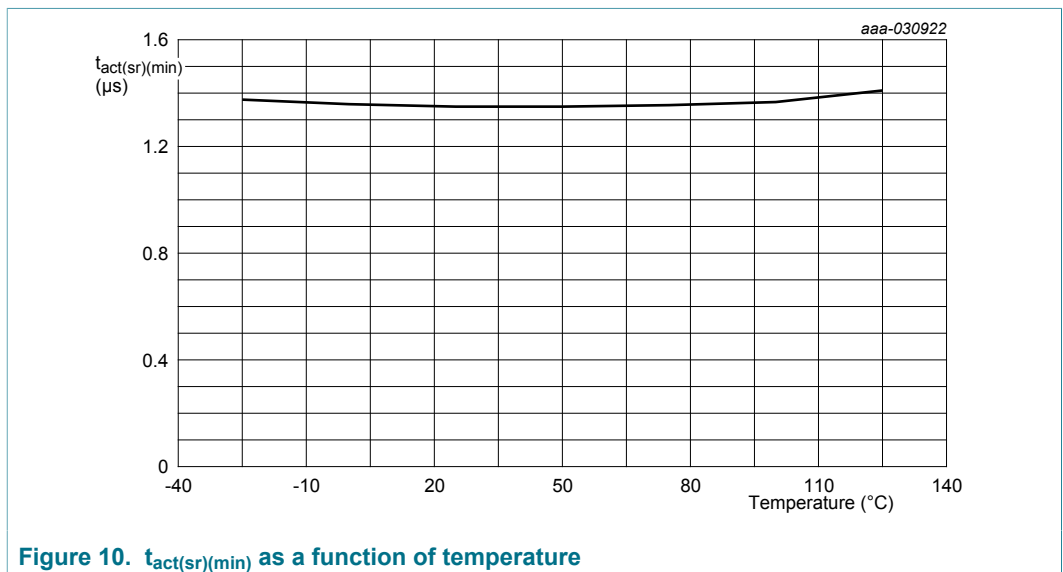

13 Application information

A flyback switched mode power supply with the TEA1999TS consists of a primary side controller with a primary switch, a transformer, and an output stage. To obtain low conduction loss rectification, an SR MOSFET is used in the output stage. The SR MOSFET can be placed low-side (see [Figure 3](#)) or can be placed high-side (see [Figure 11](#)). In the high-side application, the TEA1999TS is self-supplying. The capacitor on the CAP pin supplies the TEA1999TS. When the drain voltage is positive, it is charged via the DRAIN pin.

The gate drive voltage for the synchronous rectifier switch is derived from the voltage difference between the corresponding drain sense and source sense pins.

Special attention must be paid to the connection of the drain sense and source sense pins. The voltages measured on these pins are used for the gate drive voltage. Wrong measurement results in a less efficient gate drive because a gate voltage that is either too low or too high. The connections to these pins must not interfere with the power wiring.

The power wiring conducts currents with high di/dt values. It can easily cause measurement errors resulting from induced voltages due to parasitic inductances. The separate source sense pins make it possible to sense the source voltage of the external MOSFETs directly, without having to use the current carrying power ground tracks.

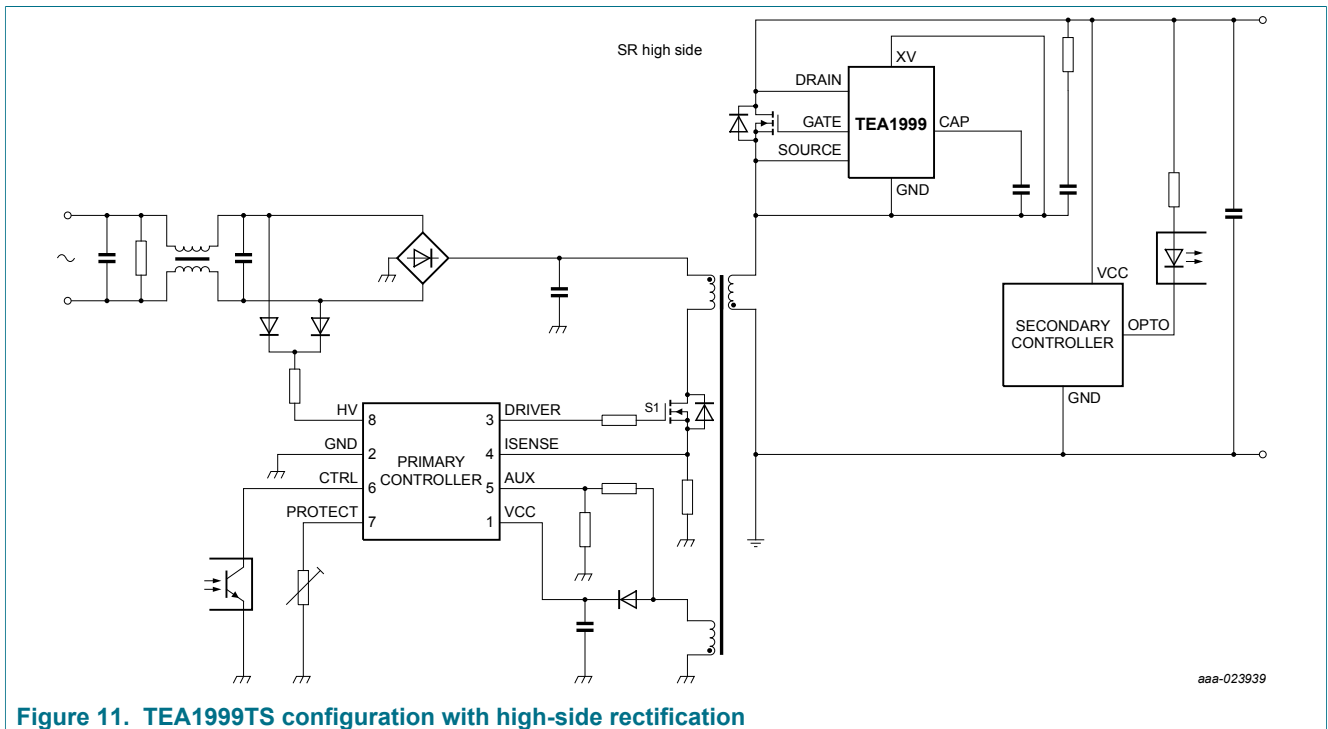

Figure 11. TEA1999TS configuration with high-side rectification

Some important guidelines for a good layout:

- Keep the trace from the DRAIN pin to the MOSFET drain as short as possible.
- Keep the trace from the SOURCE pin to the MOSFET source as short as possible.
- Keep the area of the loop from the DRAIN pin to the MOSFET drain, to the MOSFET source, and to the SOURCE pin as small as possible. Make sure that the overlap of this loop over the power drain track or the power source track is as small as possible.
- Keep the track from the GATE pin to the gate of the MOSFET as short as possible.
- Use separate clean tracks for the XV and GND pins. If possible, use a small ground plane underneath the IC, which improves the heat dispersion.

14 Package outline

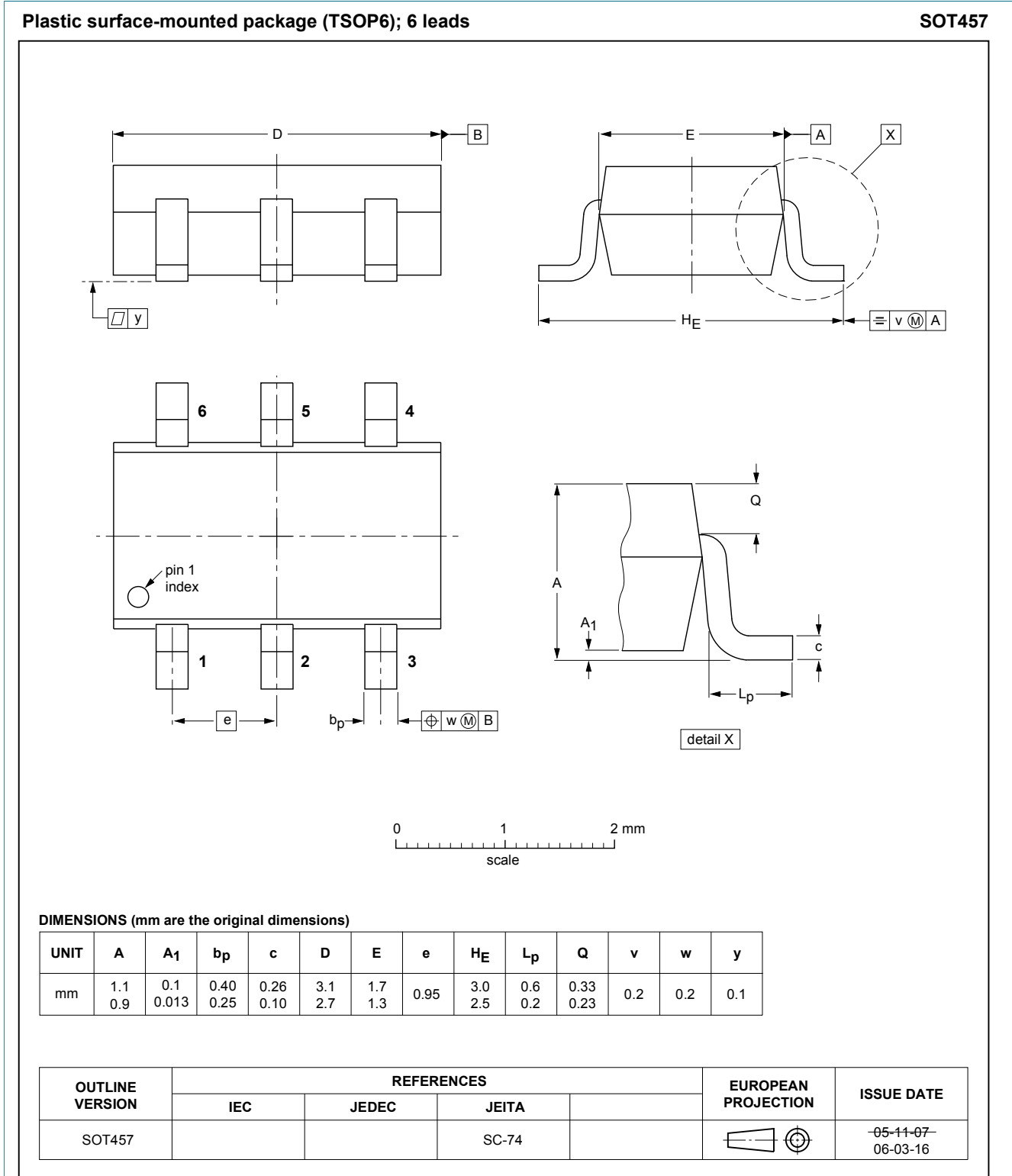

Figure 12. Package outline SOT457 (TSOP6)

15 Revision history

Table 8. Revision history

Document ID	Release date	Data sheet status	Change notice	Supersedes
TEA1999TS	20180912	Product data sheet	-	-

16 Legal information

16.1 Data sheet status

Document status ^{[1][2]}	Product status ^[3]	Definition
Objective [short] data sheet	Development	This document contains data from the objective specification for product development.
Preliminary [short] data sheet	Qualification	This document contains data from the preliminary specification.
Product [short] data sheet	Production	This document contains the product specification.

[1] Please consult the most recently issued document before initiating or completing a design.

[2] The term 'short data sheet' is explained in section "Definitions".

[3] The product status of device(s) described in this document may have changed since this document was published and may differ in case of multiple devices. The latest product status information is available on the Internet at URL <http://www.nxp.com>.

16.2 Definitions

Draft — The document is a draft version only. The content is still under internal review and subject to formal approval, which may result in modifications or additions. NXP Semiconductors does not give any representations or warranties as to the accuracy or completeness of information included herein and shall have no liability for the consequences of use of such information.

Short data sheet — A short data sheet is an extract from a full data sheet with the same product type number(s) and title. A short data sheet is intended for quick reference only and should not be relied upon to contain detailed and full information. For detailed and full information see the relevant full data sheet, which is available on request via the local NXP Semiconductors sales office. In case of any inconsistency or conflict with the short data sheet, the full data sheet shall prevail.

Product specification — The information and data provided in a Product data sheet shall define the specification of the product as agreed between NXP Semiconductors and its customer, unless NXP Semiconductors and customer have explicitly agreed otherwise in writing. In no event however, shall an agreement be valid in which the NXP Semiconductors product is deemed to offer functions and qualities beyond those described in the Product data sheet.

16.3 Disclaimers

Limited warranty and liability — Information in this document is believed to be accurate and reliable. However, NXP Semiconductors does not give any representations or warranties, expressed or implied, as to the accuracy or completeness of such information and shall have no liability for the consequences of use of such information. NXP Semiconductors takes no responsibility for the content in this document if provided by an information source outside of NXP Semiconductors. In no event shall NXP Semiconductors be liable for any indirect, incidental, punitive, special or consequential damages (including - without limitation - lost profits, lost savings, business interruption, costs related to the removal or replacement of any products or rework charges) whether or not such damages are based on tort (including negligence), warranty, breach of contract or any other legal theory. Notwithstanding any damages that customer might incur for any reason whatsoever, NXP Semiconductors' aggregate and cumulative liability towards customer for the products described herein shall be limited in accordance with the Terms and conditions of commercial sale of NXP Semiconductors.

Right to make changes — NXP Semiconductors reserves the right to make changes to information published in this document, including without limitation specifications and product descriptions, at any time and without

notice. This document supersedes and replaces all information supplied prior to the publication hereof.

Suitability for use — NXP Semiconductors products are not designed, authorized or warranted to be suitable for use in life support, life-critical or safety-critical systems or equipment, nor in applications where failure or malfunction of an NXP Semiconductors product can reasonably be expected to result in personal injury, death or severe property or environmental damage. NXP Semiconductors and its suppliers accept no liability for inclusion and/or use of NXP Semiconductors products in such equipment or applications and therefore such inclusion and/or use is at the customer's own risk.

Applications — Applications that are described herein for any of these products are for illustrative purposes only. NXP Semiconductors makes no representation or warranty that such applications will be suitable for the specified use without further testing or modification. Customers are responsible for the design and operation of their applications and products using NXP Semiconductors products, and NXP Semiconductors accepts no liability for any assistance with applications or customer product design. It is customer's sole responsibility to determine whether the NXP Semiconductors product is suitable and fit for the customer's applications and products planned, as well as for the planned application and use of customer's third party customer(s). Customers should provide appropriate design and operating safeguards to minimize the risks associated with their applications and products. NXP Semiconductors does not accept any liability related to any default, damage, costs or problem which is based on any weakness or default in the customer's applications or products, or the application or use by customer's third party customer(s). Customer is responsible for doing all necessary testing for the customer's applications and products using NXP Semiconductors products in order to avoid a default of the applications and the products or of the application or use by customer's third party customer(s). NXP does not accept any liability in this respect.

Limiting values — Stress above one or more limiting values (as defined in the Absolute Maximum Ratings System of IEC 60134) will cause permanent damage to the device. Limiting values are stress ratings only and (proper) operation of the device at these or any other conditions above those given in the Recommended operating conditions section (if present) or the Characteristics sections of this document is not warranted. Constant or repeated exposure to limiting values will permanently and irreversibly affect the quality and reliability of the device.

Terms and conditions of commercial sale — NXP Semiconductors products are sold subject to the general terms and conditions of commercial sale, as published at <http://www.nxp.com/profile/terms>, unless otherwise agreed in a valid written individual agreement. In case an individual agreement is concluded only the terms and conditions of the respective agreement shall apply. NXP Semiconductors hereby expressly objects to applying the customer's general terms and conditions with regard to the purchase of NXP Semiconductors products by customer.

No offer to sell or license — Nothing in this document may be interpreted or construed as an offer to sell products that is open for acceptance or the grant, conveyance or implication of any license under any copyrights, patents or other industrial or intellectual property rights.

Export control — This document as well as the item(s) described herein may be subject to export control regulations. Export might require a prior authorization from competent authorities.

Non-automotive qualified products — Unless this data sheet expressly states that this specific NXP Semiconductors product is automotive qualified, the product is not suitable for automotive use. It is neither qualified nor tested in accordance with automotive testing or application requirements. NXP Semiconductors accepts no liability for inclusion and/or use of non-automotive qualified products in automotive equipment or applications. In the event that customer uses the product for design-in and use in automotive applications to automotive specifications and standards, customer (a) shall use the product without NXP Semiconductors' warranty of the product for such automotive applications, use and specifications, and (b) whenever customer uses the product for automotive applications beyond NXP Semiconductors' specifications such use shall be solely at customer's own risk, and (c) customer fully indemnifies NXP Semiconductors for any liability, damages or failed product claims resulting from customer design and use

of the product for automotive applications beyond NXP Semiconductors' standard warranty and NXP Semiconductors' product specifications.

Translations — A non-English (translated) version of a document is for reference only. The English version shall prevail in case of any discrepancy between the translated and English versions.

Security — While NXP Semiconductors has implemented advanced security features, all products may be subject to unidentified vulnerabilities. Customers are responsible for the design and operation of their applications and products to reduce the effect of these vulnerabilities on customer's applications and products, and NXP Semiconductors accepts no liability for any vulnerability that is discovered. Customers should implement appropriate design and operating safeguards to minimize the risks associated with their applications and products.

16.4 Trademarks

Notice: All referenced brands, product names, service names and trademarks are the property of their respective owners.

GreenChip — is a trademark of NXP B.V.

Contents

1 **General description** 1

2 **Features and benefits** 1

2.1 Efficiency features 1

2.2 Application features 1

2.3 Control features 1

3 **Applications** 2

4 **Ordering information** 2

5 **Marking** 2

6 **Block diagram** 3

7 **Pinning information** 4

7.1 Pinning 4

7.2 Pin description 4

8 **Functional description** 5

8.1 Introduction 5

8.2 Start-up and UnderVoltage LockOut (UVLO; CAP and XV pins) 5

8.3 Drain sense (DRAIN pin) 5

8.4 Synchronous rectification (DRAIN and SOURCE pins) 6

8.5 Gate driver (GATE pin) 6

8.6 Source sense (SOURCE pin) 7

8.7 Overtemperature protection (GATE pin) 7

9 **Limiting values** 8

10 **Recommended operating conditions** 8

11 **Thermal characteristics** 8

12 **Characteristics** 9

12.1 Temperature curves 11

12.1.1 Charge current (CAP pin) 11

12.1.2 Operating current (XV pin) 11

12.1.3 Driver regulation voltage 12

12.1.4 Gate pull-down resistance 12

12.1.5 Switch-off voltage 13

12.1.6 Minimum synchronous rectification active time 13

13 **Application information** 14

14 **Package outline** 16

15 **Revision history** 17

16 **Legal information** 18

Please be aware that important notices concerning this document and the product(s) described herein, have been included in section 'Legal information'.

© NXP B.V. 2018.

All rights reserved.

For more information, please visit: <http://www.nxp.com>

For sales office addresses, please send an email to: salesaddresses@nxp.com

Date of release: 12 September 2018

Document identifier: TEA1999TS

X-ON Electronics

Largest Supplier of Electrical and Electronic Components

Click to view similar products for [Power Management Specialised - PMIC category](#):

Click to view products by [NXP manufacturer](#):

Other Similar products are found below :

[LV5686PVC-XH](#) [FAN7710VN](#) [NCP391FCALT2G](#) [SLG7NT4081VTR](#) [SLG7NT4192VTR](#) [AP4313UKTR-G1](#) [AS3729B-BWLM](#)
[MB39C831QN-G-EFE2](#) [MAX4940MB](#) [LV56841PVD-XH](#) [MAX77686EWE+T](#) [AP4306BUKTR-G1](#) [MIC5164YMM](#) [PT8A3252WE](#)
[NCP392CSFCCT1G](#) [TEA1998TS/1H](#) [PT8A3284WE](#) [PI3VST01ZEEX](#) [PI5USB1458AZAEX](#) [PI5USB1468AZAEX](#) [MCP16502TAC-E/S8B](#)
[MCP16502TAE-E/S8B](#) [MCP16502TAA-E/S8B](#) [MCP16502TAB-E/S8B](#) [TCKE712BNL,RF](#) [ISL91211AIKZT7AR5874](#)
[ISL91211BIKZT7AR5878](#) [MCP16501TC-E/RMB](#) [ISL91212AIIZ-TR5770](#) [ISL91212BIIZ-TR5775](#) [CPX200D](#) [AX-3005D-3](#) [TP-1303](#) [TP-](#)
[1305](#) [TP-1603](#) [TP-2305](#) [TP-30102](#) [TP-4503N](#) [MIC5167YML-TR](#) [LPTM21-1AFTG237C](#) [LR745N8-G](#) [MPS-3003L-3](#) [MPS-3005D](#) [SPD-](#)
[3606](#) [STLUX383A](#) [TP-60052](#) [ADN8834ACBZ-R7](#) [LM26480SQ-AA/NOPB](#) [LM81BIMTX-3/NOPB](#) [LM81CIMT-3/NOPB](#)