

TWR-P1025 Tower Module Hardware User Guide

TWR-P1025HUG
Rev. 2, 4/2012



How to Reach Us:

Home Page:

www.freescale.com

Web Support:

<http://www.freescale.com/support>

USA/Europe or Locations Not Listed:

Freescale Semiconductor, Inc.
Technical Information Center, EL516
2100 East Elliot Road
Tempe, Arizona 85284
+1-800-521-6274 or
+1-480-768-2130
www.freescale.com/support

Europe, Middle East, and Africa:

Freescale Halbleiter Deutschland GmbH
Technical Information Center
Schatzbogen 7
81829 Muenchen, Germany
+44 1296 380 456 (English)
+46 8 52200080 (English)
+49 89 92103 559 (German)
+33 1 69 35 48 48 (French)
www.freescale.com/support

Japan:

Freescale Semiconductor Japan Ltd.
Headquarters
ARCO Tower 15F
1-8-1, Shimo-Meguro, Meguro-ku
Tokyo 153-0064
Japan
0120 191014 or
+81 3 5437 9125
support.japan@freescale.com

Asia/Pacific:

Freescale Semiconductor China Ltd.
Exchange Building 23F
No. 118 Jianguo Road
Chaoyang District
Beijing 100022
China
+86 010 5879 8000
support.asia@freescale.com

Information in this document is provided solely to enable system and software implementers to use Freescale Semiconductor products. There are no express or implied copyright licenses granted hereunder to design or fabricate any integrated circuits or integrated circuits based on the information in this document.

Freescale Semiconductor reserves the right to make changes without further notice to any products herein. Freescale Semiconductor makes no warranty, representation or guarantee regarding the suitability of its products for any particular purpose, nor does Freescale Semiconductor assume any liability arising out of the application or use of any product or circuit, and specifically disclaims any and all liability, including without limitation consequential or incidental damages. "Typical" parameters which may be provided in Freescale Semiconductor data sheets and/or specifications can and do vary in different applications and actual performance may vary over time. All operating parameters, including "Typicals" must be validated for each customer application by customer's technical experts. Freescale Semiconductor does not convey any license under its patent rights nor the rights of others. Freescale Semiconductor products are not designed, intended, or authorized for use as components in systems intended for surgical implant into the body, or other applications intended to support or sustain life, or for any other application in which the failure of the Freescale Semiconductor product could create a situation where personal injury or death may occur. Should Buyer purchase or use Freescale Semiconductor products for any such unintended or unauthorized application, Buyer shall indemnify and hold Freescale Semiconductor and its officers, employees, subsidiaries, affiliates, and distributors harmless against all claims, costs, damages, and expenses, and reasonable attorney fees arising out of, directly or indirectly, any claim of personal injury or death associated with such unintended or unauthorized use, even if such claim alleges that Freescale Semiconductor was negligent regarding the design or manufacture of the part.

Freescale and the Freescale logo are trademarks of Freescale Semiconductor, Inc., Reg. U.S. Pat. & Tm. Off. QUICC Engine is trademarks of Freescale Semiconductor, Inc. All other product or service names are the property of their respective owners.

© Freescale Semiconductor, Inc., 2012

Contents

Paragraph Number	Title	Page Number
Chapter 1		
TWR-P1025 Overview		
1.1	Introduction.....	1-1
1.2	Contents	1-2
1.3	Features.....	1-2
1.4	Getting Started	1-4
1.5	QorIQ P1025 Device Notification	1-4
1.6	Reference Documents	1-4
Chapter 2		
Power Requirements		
2.1	Overview.....	2-1
Chapter 3		
Hardware Description		
3.1	P1025 Microprocessor	3-1
3.2	Clocking.....	3-2
3.3	System Power	3-5
3.4	Debug Interface.....	3-5
3.5	Accelerometer	3-5
3.6	Pushbutton and LEDs	3-5
3.7	Ethernet.....	3-5
3.8	USB.....	3-7
3.9	Micro Secure Digital Card Slot (micro SDHC).....	3-8
3.10	Local Bus Interface	3-8
3.11	UART	3-8
3.12	I2C	3-9
3.13	SPI.....	3-9
3.14	DDR3	3-9
3.15	GPIO & Interrupts	3-12
Chapter 4		
Switch Table		
4.1	P1025 Jumper Table.....	4-1

Contents

Paragraph Number	Title	Page Number
Chapter 5		
Input/Output Connectors and Pin Usage Table		
5.1	LED Usage.....	5-1
5.2	I/O Connectors and Pin Usage Table.....	5-1
Chapter 6		
Tower Elevator Connections		
6.1	Overview.....	6-1
Appendix A		
Revision History		
A.1	Version Number 2.....	7-1
A.2	Version Number 1.....	7-1
A.3	Version Number 0.....	7-1

Figures

Figure Number	Title	Page Number
1-1	Freescle Tower System.....	1-1
1-2	Callouts on front side of the TWR-P1025	1-3
1-3	Callouts on back side of the TWR-P1025.....	1-3
2-1	Power Supply Barrel Connector (J2) Polarity.....	2-1
3-1	TWR-P1025 Block Diagram.....	3-1
3-2	P1025 Clocking Scheme	3-3
3-3	eTSEC connection to AR8035 PHY	3-6
3-4	NOR Local Bus Connection	3-8

Tables

Table Number	Title	Page Number
2-1	Power Distribution Summary.....	2-1
3-1	P1025 CCB to SYSCLK Ratio Selection	3-4
3-2	P1025 e500 Core 0 & 1 to CCB Clock Ratio Selection.....	3-4
3-3	P1025 DDR Clock PLL Ratio.....	3-4
3-4	CPU Speed Selection	3-4
3-5	eTSEC1 PHY Connectivity	3-6
3-6	eTSEC1 PHY Connectivity	3-7
3-7	I2C1 Connectivity	3-9
3-8	I2C2 Connectivity	3-9
3-9	DDR3 Signals	3-10
3-10	P1025 Interrupt Usage	3-13
3-11	P1025 GPIO Usage	3-13
4-1	P1025 Jumper Table.....	4-1
5-1	LED Usage Table	5-1
5-2	I/O Connectors and Pin Usage Table	5-1
6-1	TWR-P1025 Primary Connector Pinout	6-1
6-2	TWR-P1025 Primary Connector Pinout	6-4

Chapter 1

TWR-P1025 Overview

1.1 Introduction

The TWR-P1025 is a Tower Controller Module compatible with the Freescale Tower System. It can function as a stand-alone, low-cost platform for the evaluation of the QorIQ P1xxx family of microprocessor (MPU) devices. The TWR-P1025 features the QorIQ P1025 dual core processor based on the PowerPC® e500 core architecture.

The TWR-P1025 is available as a stand-alone product or can be combined with the Tower Elevator Modules (TWR-ELEV) and other Tower eco-system components to create development platforms for a wide variety of applications. [Figure 1-1](#) shows an overview of the Freescale Tower System.

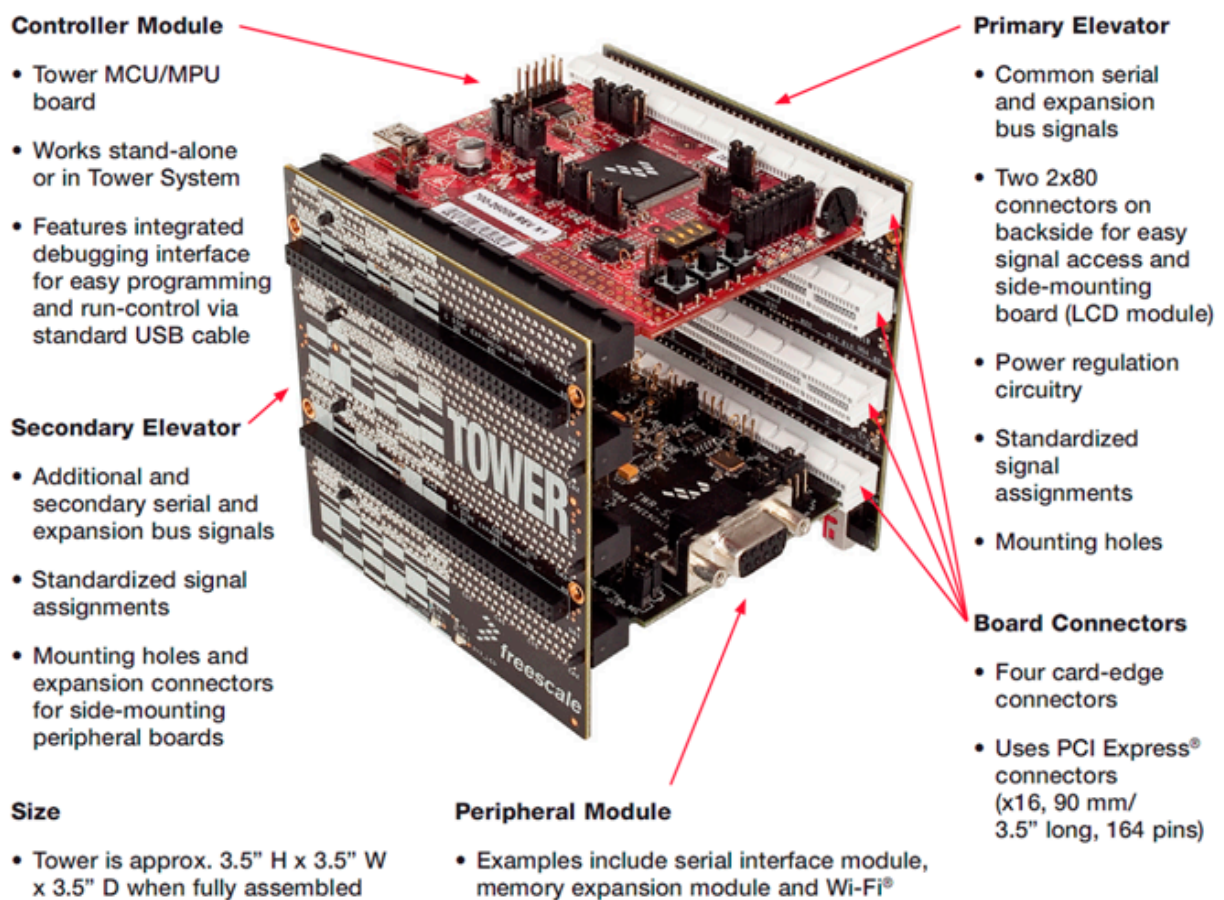

Figure 1-1. Freescale Tower System

1.2 Contents

The TWR-P1025 contents include:

- TWR-P1025 board
- Quick Start Guide

1.3 Features

The features of the TWR-P1025 Tower MPU Module:

- Tower compatible microprocessor module
- Dual core P1025 in a 561 TEPBGA package operating up to 533 MHz
- P1025 JTAG
- CPLD JTAG
- Three axis accelerometer (MMA8451Q)
- Two (2) user-controllable LEDs
- One (1) reset pushbutton switch
- Ten-way DIP Switch for configuration
- microSD card slot
- mini-PCIe slot
- Two (2) 10/100/1000Mbps Ethernet RJ45
- Two (2) USB2.0 Type A
- One (1) mini-USB TypeB dual UART
- 512 MB DDR3@667 MHz
- 64 MB Flash
- IEEE1588 pinned to header + DAC and VXCO (DNP option)

[Figure 1-2](#) and [Figure 1-3](#) show the TWR-P1025 with some of the key features.

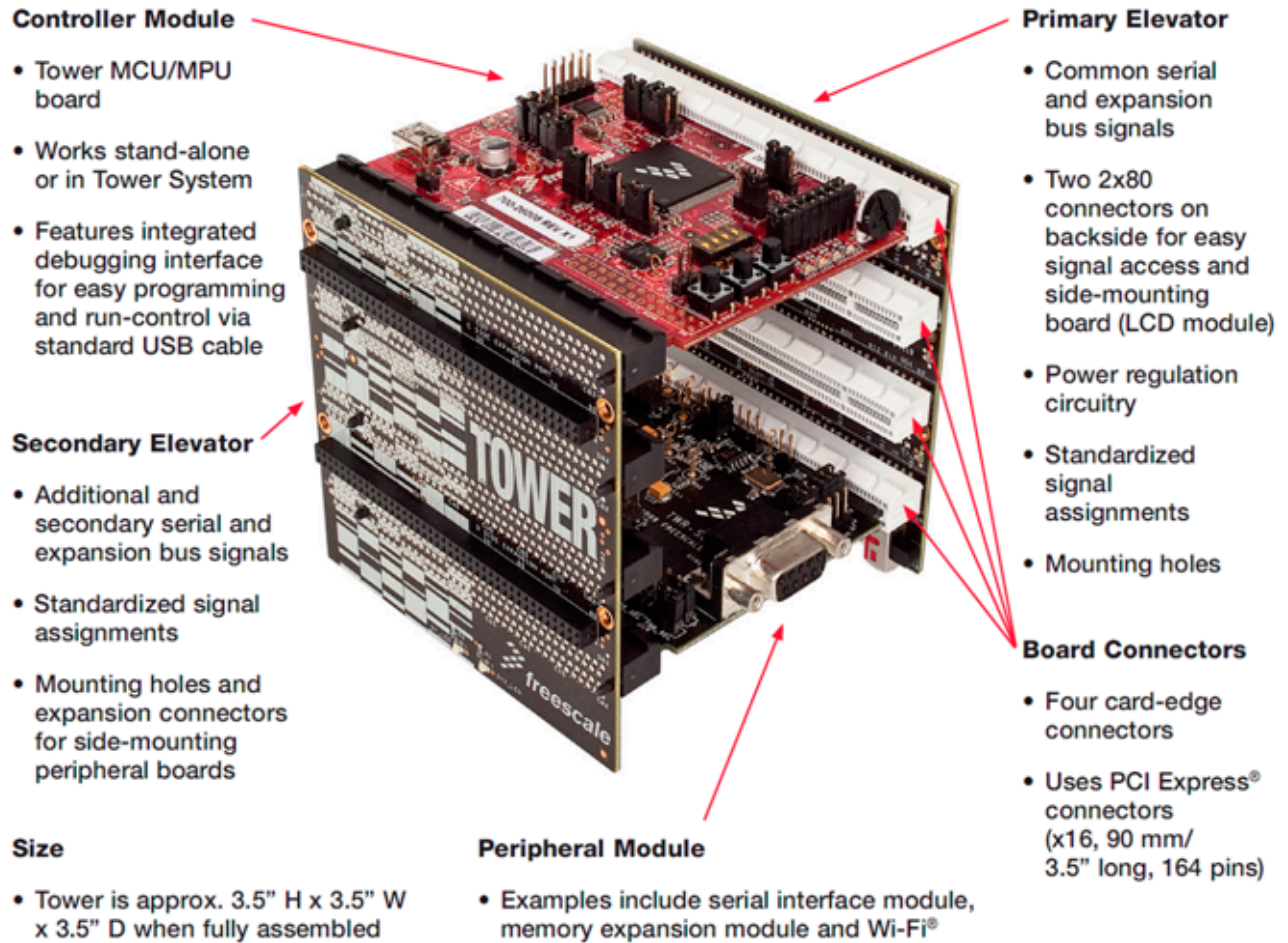

Figure 1-2. Callouts on front side of the TWR-P1025

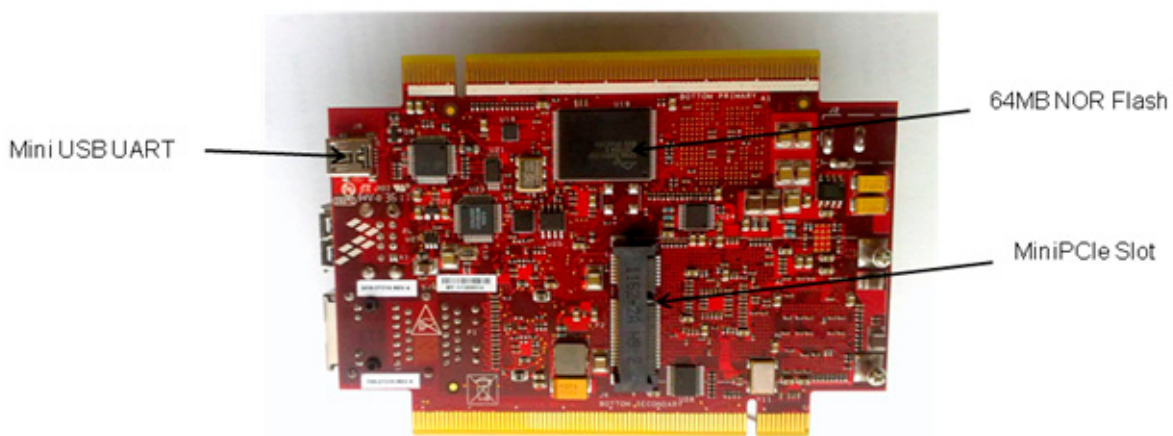

Figure 1-3. Callouts on back side of the TWR-P1025

1.4 Getting Started

Follow the printed Quick Start Guide or the interactive DVD contained in the TWR-P1025 box for recommended get started steps.

1.5 QorIQ P1025 Device Notification

The TWR-P1025 may be populated with either of the following QorIQ P1025 part numbers as indicated on a sticker on the underside of the module:

- P1025NSN5DFB, which is a non-encrypted, standard temperature device, or
- P1025NSE5DFB, which is encrypted, standard temperature device.

NOTE

For Tower modules populated with the QorIQ P1025 part number P1025NSN5DFB device, the SEC will be disabled on silicon, so features such as IPSEC in the Linux BSP will not be available.

1.6 Reference Documents

For more information on the QorIQ family, Tower System, and MPU Modules refer following documents:

- TWR-P1025-QSG: Quick Start Guide
- TWR-P1025-SCH: Schematics
- TWR-P1025-PWA: Design Package
- P1025 Reference Manual

Chapter 2

Power Requirements

2.1 Overview

The TWR-P1025 is designed to be externally powered through barrel connector J2 from a 5V@5A DC supply. The barrel connector is manufactured by SWITCHCRAFT with part number RAPC722X. The mating plug should have an inner diameter of 2.1mm and outer diameter of 5.5mm. [Figure 2-1](#) shows the polarity of the barrel connector.



Figure 2-1. Power Supply Barrel Connector (J2) Polarity

The 5V input is used to generate all voltages on the board. Additionally when used with TWR elevators and other TWR peripherals, the TWR-P1025 provides 5V and 3.3V supplies.

There are several expansion options on the board that allow external boards to interface to the TWR-P1025, such as the mini PCIe connector, USB ports and elevator expansion. As these plug in cards have variable power requirements as well as numerous population combinations the Power capability of the different expansion interfaces and the core board are listed in [Table 2-1](#). Consideration of total available power from the external supply should be considered when adding plug-in devices or using the elevator expansion.

Table 2-1. Power Distribution Summary

	Voltage (V)	Current (A)	Comment
Main Board	5	2.5A	
MiniPCIe	3.3	1A	
	1.5	0.5	
USB Port 1	5	0.5	
USB Port 2	5	0.5	
ELEVATORS	5	0.5	
	3.3	0.5	

Chapter 3 Hardware Description

The TWR-P1025 is a Tower Controller Module featuring the P1025-a dual core e500v2 based microprocessor in a 561 TEPBGA package with a maximum core operating frequency of 533MHz. It is intended to be used stand-alone or in the Freescale Tower System. Power is supplied through a 5V barrel connector. [Figure 3-1](#) shows a block diagram of the TWR-P1025. The following sections describe the hardware in more detail.

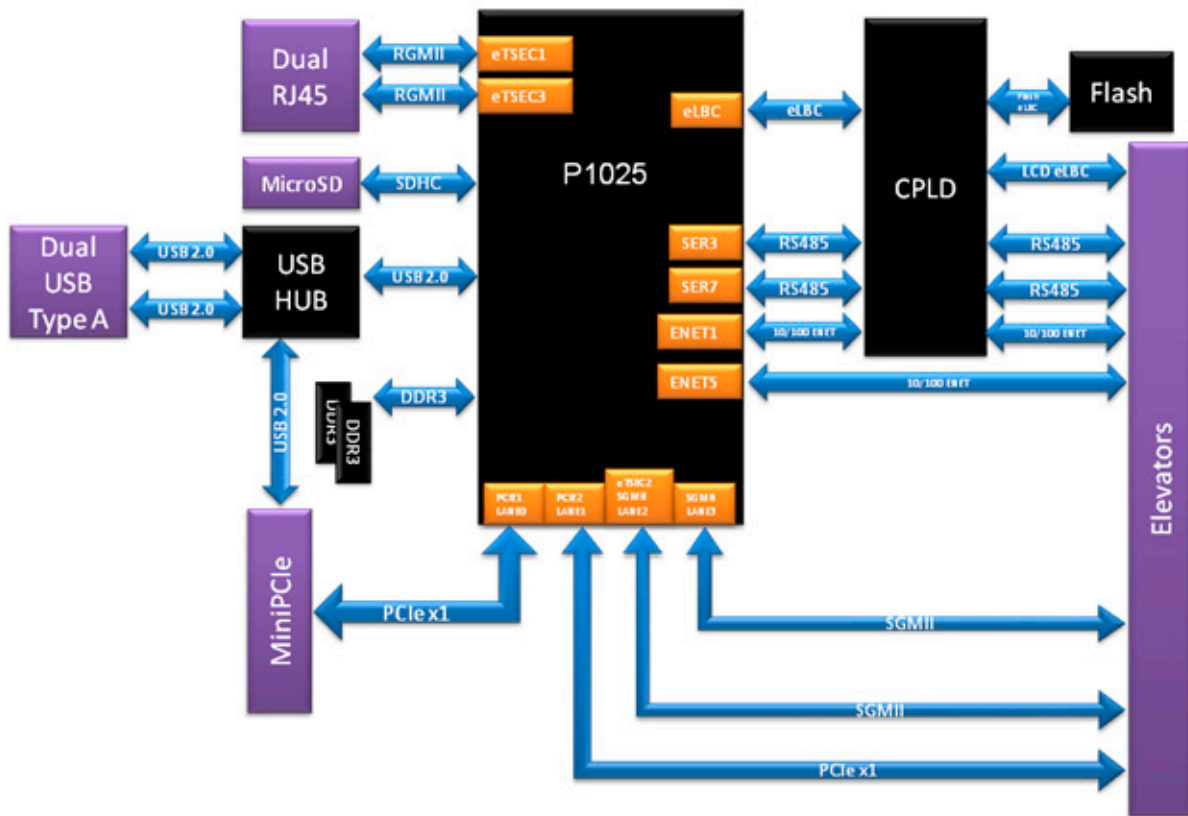

Figure 3-1. TWR-P1025 Block Diagram

3.1 P1025 Microprocessor

The TWR-P1025 module features the P1025, the key features are:

- 533 MHz maximum core operating frequency
- 561 TEPBGA, 23mm x 23mm, 1.0mm pitch package

- Dual high-performance 32-bit cores, built on Power Architecture® technology:
 - 32-bit e500v2 PowerPC core
 - 36-bit physical addressing
 - Double-precision floating-point support
 - 32 Kbyte L1 instruction cache and 32 Kbyte L1 data cache for each core
 - 400 MHz to 533 MHz clock frequency
- 256 Kbyte L2 cache with ECC. Also configurable as SRAM and stashing memory.
- Three 10/100/1000 Mbps enhanced three-speed Ethernet controllers (eTSECs)
 - TCP/IP acceleration, quality of service, and classification capabilities
 - IEEE® 1588 support
 - Lossless flow control
 - MII, RMII, RGMII, SGMII
- High-speed interfaces supporting various multiplexing options:
 - Four SerDes upto 2.5 GHz/lane multiplexed across controllers
 - Two PCI Express interfaces
 - Two SGMII interfaces
- High-speed USB controller (USB 2.0)
 - Host and device support
 - Enhanced host controller interface (EHCI)
 - ULPI interface to PHY
- Enhanced secure digital host controller (SD/MMC)
- Enhanced serial peripheral interface (eSPI)
- Integrated security engine
 - Protocol support includes ARC4, 3DES, AES, RSA/ECC, RNG, single-pass SSL/TLS
 - XOR acceleration
- 32-bit DDR3 SDRAM memory controller with ECC support
- Programmable interrupt controller (PIC) compliant with OpenPIC standard
- One four-channel DMA controller
- Two I2C controllers, DUART, timers
- Enhanced local bus controller (eLBC)
- QUICC Engine block

3.2 Clocking

The P1025 takes a single input clock, SYSCLK, as its primary clock source for the e500 cores and all of the devices and interfaces that operate synchronously with the core. As shown in [Figure 3-1](#), the SYSCLK input (frequency) is multiplied up using a phase lock loop (PLL) to create the core complex bus (CCB) clock (also called the platform clock). The CCB clock is used by virtually all of the synchronous system logic, including the L2 cache, and other internal blocks such as the DMA and interrupt controller. The CCB

clock also feeds the PLLs in the e500 core and the PLL that create clocks for the integrated flash controller. Note that the divide-by-two CCB clock divider and the divide-by-n CCB clock divider, shown in [Figure 3-2](#), are located in the DDR and IFC blocks, respectively.

A SYSCLK of 66.667 MHz will be the default used for the design.

The DDR memory controller complex may use the platform clock or the DDRCLK, which is multiplied up using a separate PLL to create a unique DDR memory controller complex clock. In this case, the DDR complex operates asynchronous with respect to the platform clock and runs at a fixed data rate of 667MTps.

The clocks for the PCI Express and SGMII interfaces are derived from a PLL in the SerDes block. This PLL is driven by a reference clock (SD_REF_CLK/SD_REF_CLK) whose input frequency is a function of the bit rate being used (100 MHz or 125 MHz). Note that for proper PCI Express operation, the CCB clock frequency must be greater than 62.5 MHz.

The Ethernet blocks operate asynchronously with respect to the rest of the device. These blocks use receive and transmit clocks supplied by their respective PHY chips, plus a 125-MHz clock input for gigabit protocols. Data transfers are synchronized to the CCB clock internally.

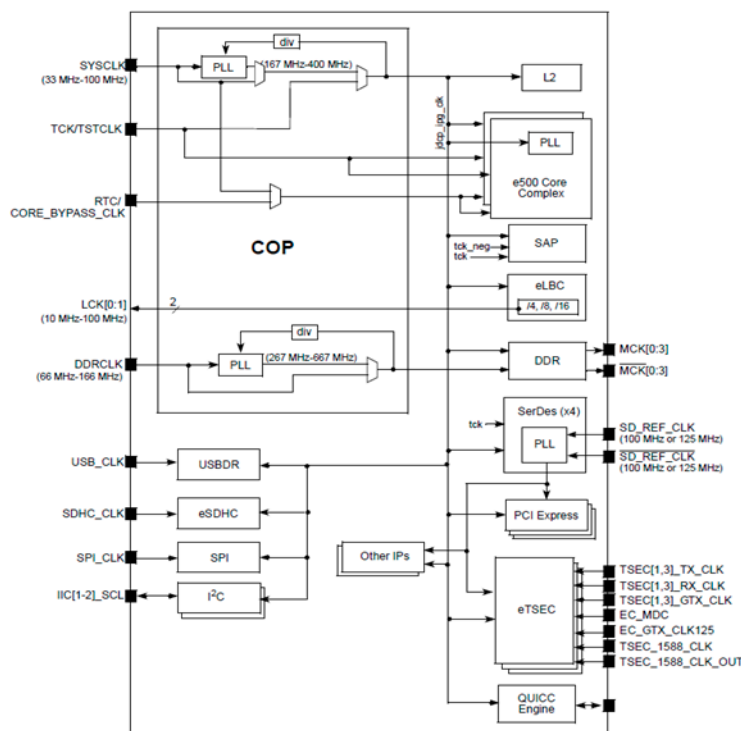

Figure 3-2. P1025 Clocking Scheme

[Table 3-1](#) and [Table 3-2](#) describe the CCB and core platform frequency ratio selection. [Table 3-3](#) describes the DDRCLK input ratio to DDR controller clock ratio.

The DDR runs at a fixed x10 multiplier to DDR_CLK.

Table 3-1. P1025 CCB to SYSCLK Ratio Selection

Functional Signals	Reset Configuration Name	Value	CCB Clock : SYSCLK Ratio
LA[29:31] No Default	cfg_sys_pll[0:2]	000	4:1
		001	5:1
		010	6:1

Table 3-2. P1025 e500 Core 0 & 1 to CCB Clock Ratio Selection

Functional Signals	Reset Configuration Name	Value	e500 Core: CCB Clock Ratio
LBCTL, LALE, LGPL2/LOE/LFRE No Default	cfg_core0_pll[0:2]	000	Reserved
		001	Reserved
		010	1:1
LWE0, UART_SOUT1, READY_P1 No Default	cfg_core1_pll[0:2]	011	3:2 (1.5:1)
		100	2:1
		101	5:2 (2.5:1)
		110	3:1
		111	Reserved

Table 3-3. P1025 DDR Clock PLL Ratio

Functional Signals	Reset Configuration Name	Value	e500 Core: CCB Clock Ratio
TSEC_1588_CLK_OUT, TSEC_1588_PULSE_OUT1, TSEC_1588_PULSE_OUT2 No Default	cfg_ddr_pll[0:2]	000	3:1
		001	4:1
		010	6:1
		011	8:1
		100	10:1
		101	Reserved
		110	Reserved
		111	Synchronous mode

Table 3-4. CPU Speed Selection

CPU_SPEED_SELECT0 SW1.7	CPU_SPEED_SELECT1 SW1.8	CORE(0 &1) Speed (MHz)	QE Speed (MHz)	SYSCLK (MHz)
ON	ON	533	266	66.667

3.3 System Power

The TWR-P1025 is powered through a barrel connector that provides 5V to the board (and elevators if present). All further operating voltages are generated via onboard regulators.

The power supply should be rated at 5V @5A.

3.4 Debug Interface

There are two JTAG connectors on board, one for the P1025 (J3) and another for the CPLD(J1). Both use standard debuggers available from Freescale and Altera respectively. Pin 1 is marked on both connectors.

Refer to the relevant debug tool for operating instructions.

3.5 Accelerometer

An MMA8451Q digital accelerometer is connected to the P1025 through its second I2C interface at address 0x1C and the accelerometers INT1 signal routed to the P1025 IRQ0.

3.6 Pushbutton and LEDs

The TWR-P1025 features one pushbutton switch connected to a reset circuit. Pressing this button initiates the reset sequence in the CPLD and performs a HRESET sequence to the P1025 as well as resetting the Ethernet PHYs, NOR Flash and USB circuitry.

Two LEDs are available to the user through software control. The P1025 GPIO pins, PB27 and PB31 are routed through the CPLD to control these two LEDs.

3.7 Ethernet

The connectivity between the P1025 and the two Atheros AR8035 GETH PHYs is described in [Table 3-5](#) & [Table 3-6](#) and illustrated in [Figure 3-3](#).

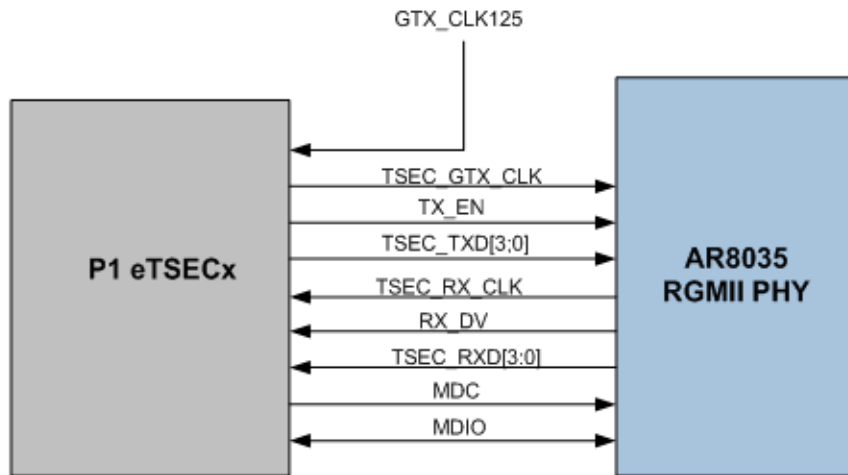

Figure 3-3. eTSEC connection to AR8035 PHY

Table 3-5. eTSEC1 PHY Connectivity

P1025 Signal	P1025 Pin	P1025 Pin Type	Description (for RGMII mode)	AR8035 Signal	AR8035 Pin
EC_GTX_CLK125	AG25	Input	Osc source for TX clock. Can be configured to feed eTSEC1 and eTSEC3	CLK_25M	NA
TSEC1_TXD03	AC22	Output	TX data bit	TXD3	37
TSEC1_TXD02	AE27	Output	TX data bit	TXD2	36
TSEC1_TXD01	AB23	Output	TX data bit	TXD1	35
TSEC1_TXD00	AD25	Output	TX data bit	TXD0	34
TSEC1_TX_EN	AD22	Output	TX data enabled/error	TX_CTL	32
TSEC1_GTX_CLK	AF26	Output	Inverted transmit clock feedback	TX_CLK	33
TSEC1_RXD03	AC24	Input	RX data bit	RXD3	25
TSEC1_RXD02	AE23	Input	RX data bit	RXD2	26
TSEC1_RXD01	AG22	Input	RX data bit	RXD1	28
TSEC1_RXD00	AE24	Input	RX data bit	RXD0	29
TSEC1_RX_DV	AE25	Input	RX data valid/error	RX_CTL	30
TSEC1_RX_CLK	AE26	Input	RX clock	RX_CLK	31

Table 3-5. eTSEC1 PHY Connectivity (continued)

P1025 Signal	P1025 Pin	P1025 Pin Type	Description (for RGMII mode)	AR8035 Signal	AR8035 Pin
EC_MDC	AG19	Output	Management clock	MDC	40
EC_MDIO	AF19	I/O	Management data	MDIO	39

Table 3-6. eTSEC1 PHY Connectivity

P1025 Signal	P1025 pin	P1025 Pin Type	Description (for RGMII mode)	AR8035 Signal	AR8035 Pin
EC_GTX_CLK125	AG25	Input	Osc source for TX clock. Can be configured to feed eTSEC1 and eTSEC3	-	23
TSEC3_TXD03	AE22	Output	TX data bit	TXD3	37
TSEC3_TXD02	AF24	Output	TX data bit	TXD2	36
TSEC3_TXD01	AG26	Output	TX data bit	TXD1	35
TSEC3_TXD00	AF21	Output	TX data bit	TXD0	34
TSEC3_TX_EN	AD27	Output	TX data enabled/error	TX_CTL	32
TSEC3_GTX_CLK	AC26	Output	Inverted transmit clock feedback	TX_CLK	33
TSEC3_RXD03	AG24	Input	RX data bit	RXD3	25
TSEC3_RXD02	AG23	Input	RX data bit	RXD2	26
TSEC3_RXD01	AC20	Input	RX data bit	RXD1	28
TSEC3_RXD00	AC23	Input	RX data bit	RXD0	29
TSEC3_RX_DV	AF27	I/O	RX data valid/error	RX_CTL	30
TSEC3_RX_CLK	AD24	Input	RX clock	RX_CLK	31
EC_MDC	AG19	Output	Management clock	MDC	40
EC_MDIO	AF19	I/O	Management data	MDIO	39

3.8 USB

The P1025 features a USB full-speed/low-speed OTG/Host/Device controller. The controller connects to the USB3300 USB PHY with the USB D+ and D- signals from the USB3300 routed to a four-port USB

hub. Port2 is routed to the miniPCIe connector with Ports 3 & 4 routed to a dual USB type B connector (J5). Both ports 3 & 4 can provide 5V@500mA to peripheral USB devices.

3.9 Micro Secure Digital Card Slot (micro SDHC)

A micro Secure Digital (SD) card slot is available on the TWR-P1025 connected to the SD Host Controller (SDHC) signals of the P1025. Refer to Table 13 "I/O Connectors and Pin Usage Table" for the SDHC signal connection details.

3.10 Local Bus Interface

The P1025 local bus interface is used for the NOR flash and elevator Local bus expansion. The local bus is routed to the CPLD where the LAD lines are demultiplexed.

A Spansion SP29GL512S Flash providing 64Mbytes of memory is used on the P1025 Tower Module to provide code storage for boot and application code. Some of the connections are direct between the P1025's GPCM controlled memory controller and the Flash device. However the data bus is multiplexed with the address bus, therefore a latch/mux is required. Typically this would be implemented in a separate logic device, though the board contains a CPLD that has all these signals routed to it. The latch/mux logic is implemented in the CPLD. The CPLD also drives reset to the Flash device at power up. The interconnect between the devices is illustrated in Figure 3-4.

Additionally a subset of the local bus is routed from the CPLD to the primary elevator. This subset is intended to be used as interface to the TWR-LCD panel.

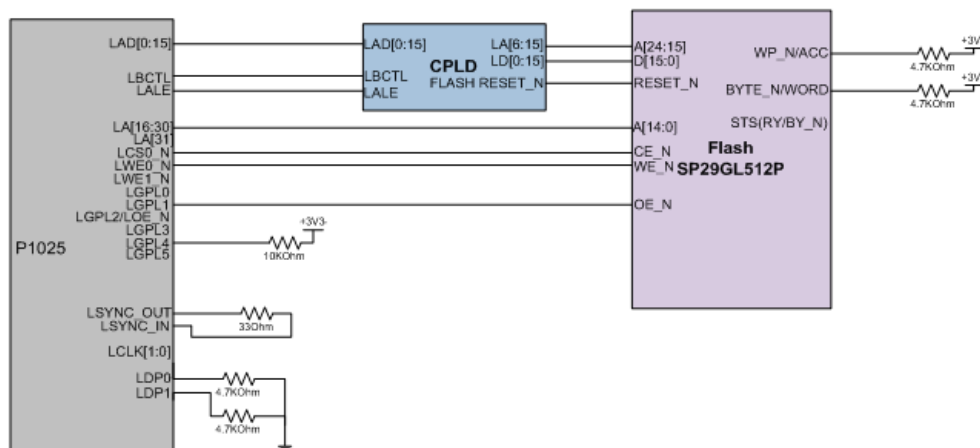

Figure 3-4. NOR Local Bus Connection

3.11 UART

The two P1025 UARTs are routed to the FDTI dual USB to RS232 convertor. The UART is typically used as a terminal on a remote host to provide input and output from the devices operating system, for example, u-boot/Linux.

Serial connectivity for both P1025 cores is provided through the mini type B USB connector (labeled mini USB UART in [Figure 1-3](#)). Note that the USB Drivers should be installed onto the host PC before the serial terminal can be used. These can be downloaded from;

<http://www.ftdichip.com/Drivers/VCP.htm> (FT2232)

A serial terminal can be set up using a PC communication program such as hyper terminal set to 115200 Baud, 8 data bits, no parity, 1 stop bit. You should select the first COM port assigned to the USB UART Virtual COM port.

3.12 I2C

There are two I2C buses on the P1025, I2C1 and I2C2. I2C1 is intended for Boot Sequencer operation. I2C2 is used for peripherals. [Table 3-7](#) & [Table 3-8](#) list the I2C devices attached to each bus.

Table 3-7. I2C1 Connectivity

Address	Device
0x50	M24256-BWDW6TP 2K EEPROM (16-bit address)

Table 3-8. I2C2 Connectivity

Address	Device
0x1C	MMA8451Q 3 Axis accelerometer
0x23	GPIO expander
0x52	AT24C01B 1K Board EEPROM (8-bit address)
TBD	Primary elevator
TBD	miniPCIe Slot

3.13 SPI

The P1025 SPI is used to control the optional 50 MHz VXCO (DNP by default) and is also routed to the tower primary elevator.

3.14 DDR3

512 MBytes of memory is connected to the P1025 32-bit DDR3 controller. The 512 MByte comprises of two 128 Mbit x 32 bits x 8 banks (2-Gbit) devices (Micron MT41J128M16HA-125G).

The DDR3-SDRAM is configured with 14 row address lines, 10 column address lines, and 8 banks. Control of each memory device is through the CS0 signal. Individual differential clocks and their associated enable signal are routed to each memory.

Every DDR3 signal can be considered to be a member of one of four separate groups. Each group has unique rules in terms of signal connection and signal routing. The four groups and connectivity between controller and Memory are shown in [Table 3-9](#).

Table 3-9. DDR3 Signals

Signal Group	P1 Signal	DDR3 Device 1 Signal	DDR3 Device 2 Signal	Termination/ Notes	Description
Address and Command	MA[13:0]	A[13:0]	A[13:0]	47 Ohm to VTT	Address bus
	MBA[2:0]	BA[2:0]	BA[2:0]	47 Ohm to VTT	Bank Address Bus
	MWE	WE	WE	47 Ohm to VTT	Write Enable
	MCAS	CAS	CAS	47 Ohm to VTT	Column Address Strobe
	MRAS	RAS	RAS	47 Ohm to VTT	Row Address Strobe
Control	MCKE0	CKE	CKE	47 Ohm to VTT	Clock Enable
	MCKE1			47 Ohm to VTT	Clock Enable
	MCS0	CS	CS	47 Ohm to VTT	Chip Select
	MODT0	ODT	ODT	47 Ohm to VTT	On-Die Termination
	MODT1			47 Ohm to VTT	On-Die Termination
Data	MDQS0+/-	LDQS+/-		ODT	Data Strobes/complement
	MDQS1+/-	UDQS+/-		ODT	Data Strobes/complement
	MDQS2+/-		LDQS+/-	ODT	Data Strobes/complement
	MDQS3+/-		UDQS+/-	ODT	Data Strobes/complement
	NC				
	MDM0	LDM		ODT	Data Mask
	MDM1	UDM		ODT	Data Mask
	MDM2		LDM	ODT	Data Mask
	MDM3		UDM	ODT	Data Mask
	MDQ[7:0]	DQ[7:0]		ODT	Data Bus
	MDQ[15:8]	DQ[15:8]		ODT	Data Bus
	MDQ[23:16]		DQ[7:0]	ODT	Data Bus
	MDQ[31:24]		DQ[15:8]	ODT	Data Bus

Table 3-9. DDR3 Signals (continued)

Signal Group	P1 Signal	DDR3 Device 1 Signal	DDR3 Device 2 Signal	Termination/ Notes	Description
Clocks	MCK0+/-	MCK0+/-	MCK0+/-		Clock/compleme nt
	MCK1+/-	NC	NC		
Misc	ZQ			240 Ohm to VSSQ (GND)	ZQ calibration
	MDIC0			Half Strength mode 40ohm to GND	Driver calibration
	MDIC1			Half Strength mode 40ohm to GVDD	Driver calibration
		RESET	RESET	1.5V Tolerant	Device Reset

The codewarrior initialization for the DDR3 controller are:

```
# DDR Controllers Setup

# DDR_SDRAM_CFG
reg ${DDR_CONT_GROUP}DDR_SDRAM_CFG = 0x470C0000
#CS0_BNDS
reg ${DDR_CONT_GROUP}CS0_BNDS = 0x0000001f

#CS1_BNDS
reg ${DDR_CONT_GROUP}CS1_BNDS = 0x00000000

#CS0_CNFG
reg ${DDR_CONT_GROUP}CS0_CONFIG = 0x80014202

#CS1_CNFG
reg ${DDR_CONT_GROUP}CS1_CONFIG = 0x00000000

# TIMING_CFG_0
#reg ${DDR_CONT_GROUP}TIMING_CFG_0 = 0x00330004
reg ${DDR_CONT_GROUP}TIMING_CFG_0 = 0x00220004
# TIMING_CFG_1
#reg ${DDR_CONT_GROUP}TIMING_CFG_1 = 0x6f6b4846
reg ${DDR_CONT_GROUP}TIMING_CFG_1 = 0x5c5b6544

# TIMING_CFG_2
#reg ${DDR_CONT_GROUP}TIMING_CFG_2 = 0x0fa8c8cf
reg ${DDR_CONT_GROUP}TIMING_CFG_2 = 0x0fa880de

# TIMING_CFG_3
#reg ${DDR_CONT_GROUP}TIMING_CFG_3 = 0x00020000
reg ${DDR_CONT_GROUP}TIMING_CFG_3 = 0x00020000

# DDR_SDRAM_CFG_2
#reg ${DDR_CONT_GROUP}DDR_SDRAM_CFG_2 = 0x04401040
reg ${DDR_CONT_GROUP}DDR_SDRAM_CFG_2 = 0x04401050
```

```

# DDR_SDRAM_MODE
#reg ${DDR_CONT_GROUP}DDR_SDRAM_MODE = 0x40461520
reg ${DDR_CONT_GROUP}DDR_SDRAM_MODE = 0x80461320

# DDR_SDRAM_MODE_2
#reg ${DDR_CONT_GROUP}DDR_SDRAM_MODE_2 = 0x8000c000
reg ${DDR_CONT_GROUP}DDR_SDRAM_MODE_2 = 0x00008000

# DDR_SDRAM_MD_CNTL
#reg ${DDR_CONT_GROUP}DDR_SDRAM_MD_CNTL = 0x00000000
reg ${DDR_CONT_GROUP}DDR_SDRAM_MD_CNTL = 0x00000000

# DDR_SDRAM_INTERVAL
#reg ${DDR_CONT_GROUP}DDR_SDRAM_INTERVAL = 0x0c300000
reg ${DDR_CONT_GROUP}DDR_SDRAM_INTERVAL = 0x09480000

# DDR_DATA_INIT
reg ${DDR_CONT_GROUP}DDR_DATA_INIT = 0xdeadbeef

# DDR_SDRAM_CLK_CNTL
reg ${DDR_CONT_GROUP}DDR_SDRAM_CLK_CNTL = 0x03000000

# TIMING_CFG_4
reg ${DDR_CONT_GROUP}TIMING_CFG_4 = 0x00220001

# TIMING_CFG_5
reg ${DDR_CONT_GROUP}TIMING_CFG_5 = 0x03402400

# DDR_ZQ_CNTL
reg ${DDR_CONT_GROUP}DDR_ZQ_CNTL = 0x89080600

# DDR_WRLVL_CNTL
#reg ${DDR_CONT_GROUP}DDR_WRLVL_CNTL = 0x8655a608
reg ${DDR_CONT_GROUP}DDR_WRLVL_CNTL = 0x8655a608

# DDR_CDR_1
reg ${DDR_CONT_GROUP}DDRCDR_1 = 0x00000000

# DDR_CDR_2
reg ${DDR_CONT_GROUP}DDRCDR_2 = 0x00000000

#delay before enable
wait 500

# DDR_SDRAM_CFG
reg ${DDR_CONT_GROUP}DDR_SDRAM_CFG = 0xc70c0000

#wait for DRAM data initialization
wait 2000

```

3.15 GPIO & Interrupts

Table 3-10 lists external interrupt sources of P1025.

Table 3-10. P1025 Interrupt Usage

IRQ	Usage
0	Accelerometer
1	TSEC1
2	TSEC3
3	GPIO Expander
4	Unused (Connected to CPLD)
5	Elevator Common Interrupt (this is a logical AND of ELEV_IRQ_[A:H] on the primary elevator.

Table 3-11. P1025 GPIO Usage

GPIO	Usage
GPIO_EXPAND0	Primary elevator GPIO1
GPIO_EXPAND1	Primary elevator GPIO5
GPIO_EXPAND2	Primary elevator GPIO7
GPIO_EXPAND3	Primary elevator GPIO8
GPIO_EXPAND4	Primary elevator GPIO9
GPIO_EXPAND5	Primary elevator GPIO14
GPIO_EXPAND6	Primary elevator GPIO15
GPIO_EXPAND7	Primary elevator GPIO16
GPIO_EXPAND8	Secondary elevator GPIO27/J4.13
GPIO_EXPAND9	Secondary elevator GPIO28/J4.15
GPIO_EXPAND10	Secondary elevator GPIO17/J4.17
GPIO_EXPAND11	Secondary elevator GPIO26/J4.16
GPIO_EXPAND12	Primary elevator GPIO4/J4.18
GPIO_EXPAND13	Primary elevator GPIO6/J4.20
GPIO_EXPAND14	Unused/CPLD
GPIO_EXPAND15	Unused/CPLD
CE_PB27	LED D2
CE_PB31	LED D3

Chapter 4 Switch Table

4.1 P1025 Jumper Table

There are several switches on the TWR-P1025 that provide configuration selection and signal isolation (Table 4-1). The default switch settings are shown in red.

Table 4-1. P1025 Jumper Table

Feature	Settings [OFF=1 ON=0]	Comments										
S1.1	OFF ON	Reserved										
S1.2	OFF ON	PCIE_HOST_AGENT Selection P1025 is Host P1025 is Agent										
S1.3	OFF ON	Reserved										
S1.4	OFF ON	CFG_CPU0_1_BOOT Core0 boots, Core 1 in holdoff after reset Both Cores run after reset										
S1.5	OFF ON	BOOT_SEQ Boot Sequencer OFF Boot Sequencer ON										
S1.6	OFF ON	LOCALBUS_QE_MUXSEL local bus pins muxed with QE function as local bus in CPLD local bus pins muxed with QE function as QE pins in CPLD										
S1.7 S1.8	<table border="1"> <thead> <tr> <th>CPU_SPEED_SELECT0 SW1.7</th> <th>CPU_SPEED_SELECT1 SW1.8</th> <th>CORE(0 & 1) Speed (MHz)</th> <th>QE Speed (MHz)</th> <th>SYSCLK (MHz)</th> </tr> </thead> <tbody> <tr> <td>ON</td> <td>ON</td> <td>533</td> <td>266</td> <td>66.667</td> </tr> </tbody> </table>	CPU_SPEED_SELECT0 SW1.7	CPU_SPEED_SELECT1 SW1.8	CORE(0 & 1) Speed (MHz)	QE Speed (MHz)	SYSCLK (MHz)	ON	ON	533	266	66.667	<p>NOTE: All other switch settings are reserved.</p>
CPU_SPEED_SELECT0 SW1.7	CPU_SPEED_SELECT1 SW1.8	CORE(0 & 1) Speed (MHz)	QE Speed (MHz)	SYSCLK (MHz)								
ON	ON	533	266	66.667								
S1.9	OFF ON	ETH_TDM_SEL Ethernet1 clock routed to P1025 through CPLD TDM Clock routed to P1025 through CPLD										
S1.10	OFF ON	PROFIBUS_MODE_SEL normal mode - RTS inverted debug mode – RTS connected to CTS										

Chapter 5

Input/Output Connectors and Pin Usage Table

5.1 LED Usage

Table 5-1 provides details on which P1025 pins are used to communicate with the LEDs, switches, and other I/O interfaces onboard the TWR-P1025.

Table 5-1. LED Usage Table

Description	Ref	Color	LED On	LED Off
UART Activity	D1	Orange	Flash for Activity	Off for no Activity
CPLD	D2	Green	User programmable	User programmable
CPLD	D3	Green	User programmable	User programmable
3V3 Power	D5	Green	3V3 Power ON	3V3 Power OFF
P1025 ASLEEP	D7	Green	ASLEEP Status	ASLEEP Status
Ethernet eTSEC1	Left up	Green	ON - Link Blink - Activity	No Link
Ethernet eTSEC1	Right up	Green/Orange	Orange - 1000Mbps Green - 100Mbps	10Mbps
Ethernet eTSEC3	Left down	Green	ON - Link Blink - Activity	No Link
Ethernet eTSEC3	Right down	Green/Orange	Orange - 1000Mbps Green - 100Mbps	10Mbps

5.2 I/O Connectors and Pin Usage Table

Table 5-2 provides details on I/O connector and Pin usage.

Table 5-2. I/O Connectors and Pin Usage Table

Feature	Connection	Port Pin	Pin Function
FDTI USB-to-serial Bridge	VBUS	J8.1	+5V In
	D-	J8.2	USB_Data-
	D+	J8.3	USB_Data+

Table 5-2. I/O Connectors and Pin Usage Table (continued)

Feature	Connection	Port Pin	Pin Function
	ID	J8.4	N/C
	G	J8.5	Ground
SD Card Slot	SD Data2	CN1.1	SDHC_D2
	SD Data3	CN1.2	SDHC_D3
	SD Command	CN1.3	SDHC_CMD
	VDD	CN1.4	+3.3V
	SD Clock	CN1.5	SDHC_CLK
	GND	CN1.6	Ground
	SD Data0	CN1.7	SDHC_D0
	SD Data1	CN1.8	SDHC_D1
	CD_SW	CN1.9	SD Card Detect (inverted polarity)
	CD_COMMON	CN1.10	+3V3
	GND	CN1.11	Ground
	GND	CN1.12	Ground
	GND	CN1.13	Ground
	GND	CN1.14	Ground
Pushbuttons	SW1 (RESET)	-	BOARD RESET
CPU JTAG/COP	CPU_TDO	J3.1	Test Data In
	-	J3.2	-
	CPU_TDI	J3.3	Test Data Out
	CPU_TRST_N	J3.4	Test Reset
	CPU_TCLK	J3.5	Test CLK
	+3.3V	J3.6	Power
	CPU_TMS	J3.7	Test Mode Select
	CKSTP_IN_N	J3.8	Checkstop In
		J3.9	-
	-	J3.10	-
	COP_SRST_N	J3.11	COP Soft Reset
	GND	J3.12	Ground
	COP_HRST_N	J3.13	COP Hard Reset
	-	J3.14	-

Table 5-2. I/O Connectors and Pin Usage Table (continued)

Feature	Connection	Port Pin	Pin Function
	CKSTP_OUT_N	J3.15	Checkstop Out
	GND	J3.16	Ground
CPLD JTAG	CPLD_JTAG_TCK	J1.1	Test CLK
	GND	J1.2	Ground
	CPLD_JTAG_TDO	J1.3	Test Data Out
	+3.3V	J1.4	Power
	CPLD_JTAG_TMS	J1.5	Test Mode Select
	-	J1.6	-
	-	J1.7	-
	-	J1.8	-
	CPLD_JTAG_TDI	J1.9	Test Data In
	GND	J1.10	Ground
QE Serial Expansion	GND	J4.1	Ground
	+3.3V	J4.2	Power
	SER7_RXD0	J4.3	UCC7 RXD0
	SER3_RXD0	J4.4	UCC3 RXD0
	SER7_TXD0	J4.5	UCC7 TXD0
	SER3_TXD0	J4.6	UCC3 RXD0
	SER7_RTS_B	J4.7	UCC7 RTS_B
	GND	J4.8	Ground
	SER7_CTS_B	J4.9	UCC7 CTS_B
	SER3_RTS_B	J4.10	UCC3 RTS_B
	SER7_CD	J4.11	UCC7 CD
	SER3_CTS_B	J4.12	UCC3 CTS_B
	GPIO_EXPAND8	J4.13	GPIO
	SER3_CD	J4.14	UCC3 CD
	GPIO_EXPAND9	J4.15	GPIO
	GPIO_EXPAND11	J4.16	GPIO
	GPIO_EXPAND10	J4.17	GPIO
	GPIO_EXPAND12	J4.18	GPIO
	+5V0	J4.19	5V Power
	GPIO_EXPAND13	J4.20	GPIO

Table 5-2. I/O Connectors and Pin Usage Table (continued)

Feature	Connection	Port Pin	Pin Function
IEEE1588	CLK_1588_HDR	J7.1	1588_CLK_IN
	1588_PULSE_OUT2	J7.2	1588_PULSE_OUT2
	1588_PULSE_OUT1	J7.3	1588_PULSE_OUT1
	1588_CLK_OUT	J7.4	1588_CLK_OUT
	1588_TRIGIN2	J7.5	1588_TRIGIN2
	1588_ALARM_OUT1	J7.6	1588_ALARM_OUT1
	1588_TRIGIN1	J7.7	1588_TRIGIN1
	1588_ALARM_OUT2	J7.8	1588_ALARM_OUT2
Dual USB	A1	J5.1	5V Out
	A2	J5.2	USB3_DN
	A3	J5.3	USB3_DP
	A4	J5.4	Ground
	B1	J5.5	5V Out
	B2	J5.6	USB4_DN
	B3	J5.7	USB4_DP
	B4	J5.8	Ground
miniPCle	WAKE#	P2.1	Pull up to +3.3V
	+3.3V	P2.2	Power
	RSV	P2.3	Reserved
	GND	P2.4	Ground
	RSV	P2.5	Reserved
	+1.5V	P2.6	Power
	CLKREQ#	P2.7	-
	RSV	P2.8	Reserved
	GND	P2.9	Ground
	RSV	P2.10	Reserved
	REFCLK-	P2.11	MPCIE_CLK_N
	RSV	P2.12	Reserved
	REFCLK+	P2.13	MPCIE_CLK_P
	RSV	P2.14	Reserved
	GND	P2.15	Ground
	RSV	P2.16	Reserved
	RSV	P2.17	Reserved

Table 5-2. I/O Connectors and Pin Usage Table (continued)

Feature	Connection	Port Pin	Pin Function
	GND	P2.18	Ground
	RSV	P2.19	Reserved
	RSV	P2.20	Reserved
	GND	P2.21	Ground
	PERST#	P2.22	RST_PCIE_N
	PERN0	P2.23	PCIE_RX0_N
	+3.3V_AUX	P2.24	Power
	PERP0	P2.25	PCIE_RX0_P
	GND	P2.26	Ground
	GND	P2.27	Ground
	+1.5V	P2.28	Power
	GND	P2.29	Ground
	SMBCLK	P2.30	I2C_SCL
	PERTN0	P2.31	PCIE_TX0_N
	SMBDATA	P2.32	I2C_SDA
	PERTP0	P2.33	PCIE_TX0_P
	GND	P2.34	Ground
	GND	P2.35	Ground
	USB_D-	P2.36	USB2_DM
	RSV	P2.37	Reserved
	USB_D+	P2.38	USB2_DP
	RSV	P2.39	Reserved
	GND	P2.40	Ground
	RSV	P2.41	Reserved
	LED_WWAN	P2.42	-
	RSV	P2.43	Reserved
	LED_WLAN	P2.44	-
	RSV	P2.45	Reserved
	LED_WPAN	P2.46	-
	RSV	P2.47	Reserved
	+1.5V	P2.48	Power
	RSV	P2.49	Reserved
	GND	P2.50	Ground

Table 5-2. I/O Connectors and Pin Usage Table (continued)

Feature	Connection	Port Pin	Pin Function
	RSV	P2.51	Reserved
	+3.3V	P2.52	Power

Chapter 6

Tower Elevator Connections

6.1 Overview

The TWR-P1025 features two expansion card-edge connectors that interface to the primary and secondary elevator boards in a Tower system. The Primary Connector (comprised of sides A and B) is utilized by the TWR-P1025 while the Secondary Connector (comprised of sides C and D) makes connections to the the SER3 & 7 Serial ports as well as ENET5 RMI and three SERDES lanes. Table 14 provides the pinout for the Primary Connector. Table 15 provides the pinout for the Secondary Connector.

Table 6-1. TWR-P1025 Primary Connector Pinout

Pin#	Side B		Pin#	Side A	
	Name	Usage		Name	Usage
B1	5V	5.0V Power	A1	5V	5.0V Power
B2	GND	Ground	A2	GND	Ground
B3	3.3V	3.3V Power	A3	3.3V	3.3V Power
B4	ELE_PS_SE NSE	Elevator Power Sense	A4	3.3V	3.3V Power
B5	GND	Ground	A5	GND	Ground
B6	GND	Ground	A6	GND	Ground
B7	SDHC_CLK / SPI1_CLK		A7	SCL0	I2C1_SCL
B8	SDHC_D3 / SPI1_CS1_b		A8	SDA0	I2C1_SDA
B9	SDHC_D3 / SPI1_CS0_b		A9	GPIO9 / CTS1	GPIO_EXPAND4
B10	SDHC_CMD / SPI1_MOSI		A10	GPIO8 / SDHC_led	GPIO_EXPAND3
B11	SDHC_D0 / SPI1_MISO		A11	GPIO7 / SD_WP_DET	GPIO_EXPAND2
B12	ETH_COL	ENET1_COL	A12	ETH_CRS	ENET1_CRS
B13	ETH_RXER	ENET1_RX_ ER	A13	ETH_MDC	QE_MDC
B14	ETH_TXCLK	ENET1_TXCL K	A14	ETH_MDIO	QE_MDIO

Table 6-1. TWR-P1025 Primary Connector Pinout (continued)

Pin#	Side B		Pin#	Side A	
B15	ETH_TXEN	ENET1_TXE N	A15	ETH_RXCLK	ENET1_RXCLK
B16	ETH_TXER	ENET1_TXE R	A16	ETH_RXDV	ENET1_RX_DV
B17	ETH_TXD3	ENET1_TXD3	A17	ETH_RXD3	ENET1_RXD3
B18	ETH_TXD2	ENET1_TXD2	A18	ETH_RXD2	ENET1_RXD2
B19	ETH_TXD1	ENET1_TXD1	A19	ETH_RXD1	ENET1_RXD1
B20	ETH_TXD0	ENET1_TXD0	A20	ETH_RXD0	ENET1_RXD0
B21	GPIO1 / RTS1	GPIO_EXPAN D0	A21	SSI_MCLK	
B22	GPIO2 / SDHC_D1		A22	SSI_BCLK	TDMA_CLK
B23	GPIO3	CE_PB1	A23	SSI_FS	TDMA_SYNC
B24	CLKIN0	ENET5_REF CLK	A24	SSI_RXD	TDMA_RXD
B25	CLKOUT1		A25	SSI_TXD	TDMA_TXD
B26	GND	Ground	A26	GND	Ground
B27	AN7		A27	AN3	
B28	AN6		A28	AN2	
B29	AN5		A29	AN1	
B30	AN4		A30	AN0	
B31	GND	Ground	A31	GND	Ground
B32	DAC1		A32	DAC0	
B33	TMR3		A33	TMR1	
B34	TMR2		A34	TMR0	
B35	GPIO4	GPIO_EXPAN D12	A35	GPIO6	GPIO_EXPAND13
B36	3.3V	3.3V Power	A36	3.3V	3.3V Power
B37	PWM7		A37	PWM3	
B38	PWM6		A38	PWM2	
B39	PWM5		A39	PWM1	
B40	PWM4		A40	PWM0	
B41	CANRX0		A41	RXD0	UART1_SIN
B42	CANTX0		A42	TXD0	UART1_SOUT
B43	1WIRE		A43	RXD1	

Table 6-1. TWR-P1025 Primary Connector Pinout (continued)

Pin#	Side B		Pin#	Side A	
B44	SPI0_MISO	SPI0_MISO	A44	TXD1	
B45	SPI0_MOSI	SPI0_MOSI	A45	VSS	
B46	SPI0_CS0_b	ELEV_SPI0_CS0_b	A46	VDDA	
B47	SPI0_CS1_b	ELEV_SPI0_CS1_b	A47	VREFA1	
B48	SPI0_CLK	SPI0_CLK	A48	VREFA2	
B49	GND	Ground	A49	GND	Ground
B50	SCL1	I2C2_SCL	A50	GPIO14	GPIO_EXPAND5
B51	SDA1	I2C2_SDA	A51	GPIO15	GPIO_EXPAND6
B52	GPIO5 / SD_CARD_DET	PTE28	A52	GPIO16	GPIO_EXPAND7
B53	USB0_DP_P DOWN		A53	GPIO17	GPIO_EXPAND10
B54	USB0_DM_P DOWN		A54	USB0_DM	
B55	IRQ_H	IRQ_H	A55	USB0_DP	
B56	IRQ_G	IRQ_G	A56	USB0_ID	
B57	IRQ_F	IRQ_F	A57	USB0_VBUS	
B58	IRQ_E	IRQ_E	A58	TMR7	
B59	IRQ_D	IRQ_D	A59	TMR6	
B60	IRQ_C	IRQ_C	A60	TMR5	
B61	IRQ_B	IRQ_B	A61	TMR4	
B62	IRQ_A	IRQ_A	A62	RSTIN_b	ELEV_RST_IN_b
B63	EBI_ALE / EBI_CS1_b	ELEV_LALE	A63	RSTOUT_b	ELEV_RST_OUT_b
B64	EBI_CS0_b	ELEV_CS1	A64	CLKOUT0	PTC3
B65	GND	Ground	A65	GND	Ground
B66	EBI_AD15	ELEV_LAD15	A66	EBI_AD14	ELEV_LAD14
B67	EBI_AD16	ELEV_LA16	A67	EBI_AD13	ELEV_LAD13
B68	EBI_AD17	ELEV_LA17	A68	EBI_AD12	ELEV_LAD12
B69	EBI_AD18	ELEV_LA18	A69	EBI_AD11	ELEV_LAD11
B70	EBI_AD19	ELEV_LA19	A70	EBI_AD10	ELEV_LAD10
B71	EBI_R/W_b	ELEV_RW	A71	EBI_AD9	ELEV_LAD9

Table 6-1. TWR-P1025 Primary Connector Pinout (continued)

Pin#	Side B		Pin#	Side A	
	EBI_OE_b	ELEV_OE		EBI_AD8	ELEV_LAD8
B72	EBI_D7	ELEV_D7	A72	EBI_AD7	ELEV_LAD7
B73	EBI_D6	ELEV_D6	A73	EBI_AD6	ELEV_LAD6
B74	EBI_D5	ELEV_D5	A74	EBI_AD5	ELEV_LAD5
B75	EBI_D4	ELEV_D4	A75	EBI_AD4	ELEV_LAD4
B76	EBI_D3	ELEV_D3	A76	EBI_AD3	ELEV_LAD3
B77	EBI_D2	ELEV_D2	A77	EBI_AD2	ELEV_LAD2
B78	EBI_D1	ELEV_D1	A78	EBI_AD1	ELEV_LAD1
B79	EBI_D0	ELEV_D0	A79	EBI_AD0	ELEV_LAD0
B80	GND	Ground	A80	GND	Ground
B81	3.3V	3.3V Power	A81	3.3V	3.3V Power
B82			A82		

Table 6-2. TWR-P1025 Primary Connector Pinout

Pin#	Side B		Pin#	Side A	
	Name	Usage		Name	Usage
D1	5V	5.0V Power	C1	5V	5.0V Power
D2	GND	Ground	C2	GND	Ground
D3	3.3V	3.3V Power	C3	3.3V	3.3V Power
D4	ELE_PS_SENSE	Elevator Power Sense	C4	3.3V	3.3V Power
D5	GND	Ground	C5	GND	Ground
D6	GND	Ground	C6	GND	Ground
D7	SPI2_CLK		C7	I2C2_SCL	
D8	SPI2_CS1_b		C8	I2C2_SDA	
D9	SPI2_CS0_b		C9	GPIO25	
D10	SPI2_MOSI		C10	ULPI_STOP	
D11	SPI2_MISO		C11	ULPI_CLK	
D12	ETH_COL		C12	GPIO26	GPIO_EXPAND11
D13	ETH_RXER	ENET5_RX_ER	C13	ETH_MDC	QE_MDC
D14	ETH_TXCLK		C14	ETH_MDIO	QE_MDIO
D15	ETH_TXEN	ENET5_TX_EN	C15	ETH_RXCLK	

Table 6-2. TWR-P1025 Primary Connector Pinout (continued)

Pin#	Side B		Pin#	Side A	
D16	GPIO18		C16	ETH_RXDV	ENET5_RX_DV
D17	GPIO19 / SDHC_D4		C17	GPIO27 / SDHC_D6	GPIO_EXPAND8
D18	GPIO20 / SDHC_D5		C18	GPIO28 / SDHC_D7	GPIO_EXPAND9
D19	ETH_TXD1	ENET5_TX D1	C19	ETH_RXD1	ENET5_RXD1 (LWE1_b)
D20	ETH_TXD0	ENET5_TX D0	C20	ETH_RXD0	ENET5_RXD0
D21	ULPI_NEXT / USB_HS_DM	GPIO_EXPAND0	C21	ULPI_DATA 0 / I2S1_MCLK	
D22	ULPI_DIR / USB_HS_DP		C22	ULPI_DATA 1 / I2S1_DOUT_SCK	
D23	ULPI_DATA5 / USB_HS_VBUS	CE_PB1	C23	ULPI_DATA 2 / I2S1_DOUT_WS	
D24	ULPI_DATA6 / USB_HS_ID	ENET5_RE FCLK	C24	ULPI_DATA 3 / I2S1_DIN0	
D25	ULPI_DATA7		C25	ULPI_DATA 4 / I2S1_DOUT_0	
D26	GND	Ground	C26	GND	Ground
D27	LCD_HSYNC / LCD_P24		C27	AN11	
D28	LCD_VSYNC / LCD_P25		C28	AN10	
D29	AN13		C29	AN9	
D30	AN12		C30	AN8	
D31	GND	Ground	C31	GND	Ground
D32	LCD_CLK / LCD_P26		C32	GPIO29 / UART2_DCD	SER3_CD
D33	TMR11		C33	TMR9	
D34	TMR10		C34	TMR8	

Table 6-2. TWR-P1025 Primary Connector Pinout (continued)

Pin#	Side B		Pin#	Side A	
D35	GPIO21	GPIO_EXPAND12	C35	GPIO30 / UART3_DCD	SER7_CD
D36	3.3V	3.3V Power	C36	3.3V	3.3V Power
D37	PWM15		C37	PWM11	
D38	PWM14		C38	PWM10	
D39	PWM13		C39	PWM9	
D40	PWM12		C40	PWM8	
D41	CAN2_RX		C41	UART2_RXD / TSI0	SER3_RXD0
D42	CAN2_TX		C42	UART2_TXD / TSI1	SER3_TXD0
D43	LCD_CONTRAST		C43	UART2_RTS / TSI2	SER3_RTS
D44	LCD_OE / LCD_P27	SPI0_MISO	C44	UART2_CTS / TSI3	SER3_CTS
D45	LCD_D0 / LCD_P0	SPI0_MOSI	C45	UART3_RXD / TSI4	SER7_RXD0
D46	LCD_D1 / LCD_P1	ELEV_SPI0_CS0_b	C46	UART3_TXD / TSI5	SER7_TXD0
D47	LCD_D2 / LCD_P2	ELEV_SPI0_CS1_b	C47	UART3_RTS / CAN3_RX	SER7_RTS
D48	LCD_D3 / LCD_P3	SPI0_CLK	C48	UART3_CTS / CAN3_TX	SER7_CTS
D49	GND	Ground	C49	GND	Ground
D50	GPIO23	I2C2_SCL	C50	LCD_D4 / LCD_P4	GPIO_EXPAND5
D51	GPIO24	I2C2_SDA	C51	LCD_D5 / LCD_P5	GPIO_EXPAND6
D52	LCD_D12 / LCD_P12	PTE28	C52	LCD_D6 / LCD_P6	GPIO_EXPAND7
D53	LCD_D13 / LCD_P13		C53	LCD_D7 / LCD_P7	GPIO_EXPAND10
D54	LCD_D14 / LCD_P14		C54	LCD_D8 / LCD_P8	
D55	IRQ_P / SPI2_CS2_b	IRQ_H	C55	LCD_D9 / LCD_P9	

Table 6-2. TWR-P1025 Primary Connector Pinout (continued)

Pin#	Side B		Pin#	Side A	
D56	IRQ_O / SPI2_CS3_b	IRQ_G	C56	LCD_D10 / LCD_P10	
D57	IRQ_N	IRQ_F	C57	LCD_D11 / LCD_P11	
D58	IRQ_M	IRQ_E	C58	I2S1_DIN_S CK	
D59	IRQ_L	IRQ_D	C59	I2S1_DIN_ WS	
D60	IRQ_K	IRQ_C	C60	I2S1_DIN1	
D61	IRQ_J	IRQ_B	C61	I2S1_DOUT 1	
D62	IRQ_I	IRQ_A	C62	LCD_D15 / LCD_P15	
D63	LCD_D18 / LCD_P18 / SD_RX_0	ELEV_SD_ RX1_P	C63	LCD_D16 / LCD_P16 / SD_GND	SD_GND
D64	LCD_D19 / LCD_P19 / SD_RXb_0	ELEV_SD_ RX1_N	C64	LCD_D17 / LCD_P17 / SD_GND	SD_GND
D65	GND	Ground	C65	GND	Ground
D66	EBI_AD20 / LCD_P42 / SD_GND	SD_GND	C66	EBI_BE_32 _24_b / LCD_P28 / SD_TX_0	ELEV_SD_TX1_P
D67	EBI_AD21 / LCD_P43 / SD_GND	SD_GND	C67	EBI_BE_23 _16_b / LCD_P29 / SD_TXb_0	ELEV_SD_TX1_N
D68	EBI_AD22 / LCD_P44 / SD_RX_1	ELEV_SD_ RX2_P	C68	EBI_BE_15 _8_b / LCD_P30 / SD_GND	SD_GND
D69	EBI_AD23 / LCD_P45 / SD_RXb_1	ELEV_SD_ RX2_N	C69	EBI_BE_7_ 0_b / LCD_P31 / SD_GND	SD_GND
D70	EBI_AD24 / LCD_P46 / SD_GND	SD_GND	C70	EBI_TSIZE0 / LCD_P32 / SD_TX_1	ELEV_SD_TX2_P
D71	EBI_AD25 / LCD_P47 / SD_GND	SD_GND	C71	EBI_TSIZE1 / LCD_P33 / SD_TXb_1	ELEV_SD_TX2_N

Table 6-2. TWR-P1025 Primary Connector Pinout (continued)

Pin#	Side B		Pin#	Side A	
D72	EBI_AD26/LCD_P48/ SD_RX_2	ELEV_SD_ RX3_P	C72	EBI_TS_b / LCD_P34 / SD_GND	SD_GND
D73	EBI_AD27/LCD_P49/ SD_RXb_2	ELEV_SD_ RX3_N	C73	EBI_TBST_ b/LCD_P35 / SD_GND	SD_GND
D74	EBI_AD28/LCD_P50/ SD_GND	SD_GND	C74	EBI_TA_b / LCD_P36 / SD_TX_2	ELEV_SD_TX3_P
D75	EBI_AD29/LCD_P51/ SD_GND	SD_GND	C75	EBI_CS4_b / LCD_P37 / SD_TXb_2	ELEV_SD_TX3_N
D76	EBI_AD30/LCD_P52/ SD_RX_3		C76	EBI_CS3_b / LCD_P38 / SD_GND	SD_GND
D77	EBI_AD31/LCD_P53/ SD_RXb_3		C77	EBI_CS2_b / LCD_P39 / SD_GND	SD_GND
D78	LCD_D20 / LCD_P20 / SD_GND	SD_GND	C78	EBI_CS1_b / LCD_P40 / SD_TX_3	
D79	LCD_D21 / LCD_P21 / SD_REFCLK	PCIE_CLK_ P	C79	GPIO31 / LCD_P41 / SD_TXb_3	
D80	LCD_D22 / LCD_P22 / SD_REFCLKb	PCIE_CLK_ N	C80	LCD_D23 / LCD_P23 / SD_GND	SD_GND
D81	GND	Ground	C81	GND	Ground
D82	3.3V	3.3V Power	C82	3.3V	3.3V Power

Appendix A

Revision History

This appendix provides a list of the major differences between current *TWR-P1025 hardware user guide* and its previous revisions.

A.1 Version Number 2

Updated section 1.5 QorIQ P1025 Device Notification.

A.2 Version Number 1

Added section 1.5 QorIQ P1025 Device Notification.

Updated Table 3.4 CPU Speed Selection.

Updated Table 4.1 P1025 Jumper Table.

A.3 Version Number 0

This is initial version of the TWR-P1025 Hardware User Guide.

X-ON Electronics

Largest Supplier of Electrical and Electronic Components

Click to view similar products for [Development Boards & Kits - Other Processors](#) category:

Click to view products by [NXP](#) manufacturer:

Other Similar products are found below :

[KIT_AURIX_TC233LP_TRB](#) [EVB-MEC1418MECC](#) [P1020RDB-PD](#) [STM8S/32-D/RAIS](#) [T4240QDS-PB](#) [SPC58EEMU](#)
[YR0K50571MS000BE](#) [QB-R5F104PJ-TB](#) [OV-7604-C7-EVALUATION-BOARD](#) [SK-AD02-D62Q1747TB](#) [ST7MDT1-EMU2](#)
[RTK5572TKCS00000BE](#) [KITAURIXTC234TFTTOBO1](#) [SL-MIPI-LVDS-HDMI-CNV4](#) [QB-R5F104LE-TB](#) [R0K521380S000BE](#) [LV-24-33](#)
[V6 44-PIN TQFP MCU CARD EMPTY](#) [LV-24-33](#) [V6 64-PIN TQFP MCU CARD EMPTY](#) [LV-24-33](#) [V6 80-PIN TQFP 1 MCU CARD](#)
[EMPTY](#) [32X32 RGB LED MATRIX PANEL - 6MM PITCH](#) [READY FOR XMEGA CASING \(WHITE\)](#) [RELAY4 BOARD](#) [ETHERNET](#)
[CONNECTOR](#) [RFID CARD 125KHZ - TAG](#) [RFID READER](#) [RFM12B-DEMO](#) [MAROON](#) [MAX232](#) [MAX3232 BOARD](#) [ARTY S7-50](#)
[THREE-AXIS ACCELEROMETER BOARD](#) [TINKERKIT HALL SENSOR](#) [TOUCHPANEL CONTROLLER](#) [MIKROBOARD FOR AVR](#)
[WITH ATMEGA128](#) [MIKROBOARD FOR PSOC WITH CY8C27643](#) [MIKRODRIVE](#) [MIKROETH 100 BOARD](#) [MIKROPROG TO ST-](#)
[LINK V2 ADAPTER](#) [BANANA PI GPIO EXTEND MODULE](#) [BATTERY BOOST SHIELD BOARD](#) [BEE PROTO](#) [BIGDSPIC6 80-PIN](#)
[TQFP 1 MCU CARD EMPTY](#) [BIPOLAR STEPPER MOTOR DRIVER](#) [MOD-28.Z](#) [MOD-30.Z](#) [MOD-37.Z](#) [MOD-50](#) [MOD-54](#) [MOD-60](#)
[MOD-64](#)