



TWR-S08PT60

User Manual

Rev. 1.0

Contents

1 Overview	3
2 Reference Documents.....	4
3 Hardware Features.....	5
3.1 Clocking	5
3.2 System Power.....	5
3.3 Debug Interface	6
3.4 RS232 Interface	7
3.5 Infrared Port.....	7
3.6 Accelerometer.....	8
3.7 TWRPI Sockets.....	9
3.8 User Interfaces.....	9
3.8.1 Push buttons.....	10
3.8.2 Touch PAD Interface.....	10
3.8.3 Potentiometer.....	11
3.9 Elevator Connections	12
3.10 Mechanical Form Factor.....	14
4 Jumper Table	15
5 Input/Output Connectors and Pin Usage Table.....	16
6 OSBDM.....	17
6.1 Bootloader Mode For MC9S08JM60	17
7 BDM interface (Optional).....	17

1 Overview

TWR-S08PT60 is a low-cost evaluation, demonstration and development board that features the 8-bit MC9S08PT60 microcontroller. The TWR-S08PT60 can operate stand-alone or as the main control board in a Tower System with peripheral modules.

The MC9S08P series are members of the low-cost, high-performance S08 family of 8-bit microcontroller units (MCUs). The MC9S08P has up to 60KB flash, 256 byte EEPROM, 4K RAM, and includes rich peripherals: timers (3 FTMs, 2 MTIMs), 3 SCIs (UARTs), 2 SPIs, I²C, ADC, ACMP, KBI, TSI and etc. It is targeted for appliance, power conversion, DC-motor control, building automation and many other general purpose applications. The Tower System module is designed for easy evaluation of these modules and to help customers quickly build a prototype for their development.

The following list summarizes the features of the TWR-S08PT60 Tower System controller module:

- 64-pin LQFP MC9S08PT60
- MC9S08JM60 based Open Source BDM (OSBDM) circuit with RS232 interface supported
- 4 user-controlled status LEDs
- 4 Capacitive Touch Pads and 2 mechanical push buttons
- Socket for Capacitive Touch Pad daughter board (Touch TWRPI)
- Socket for Tower Plug in (TWRPI: including the ADC/ACMP channels, FTM2 channels for motor control)
- Potentiometer, MMA8451Q three-axis digital accelerometer
- RS232 transceiver and 2x5 pin header
- Infrared Port

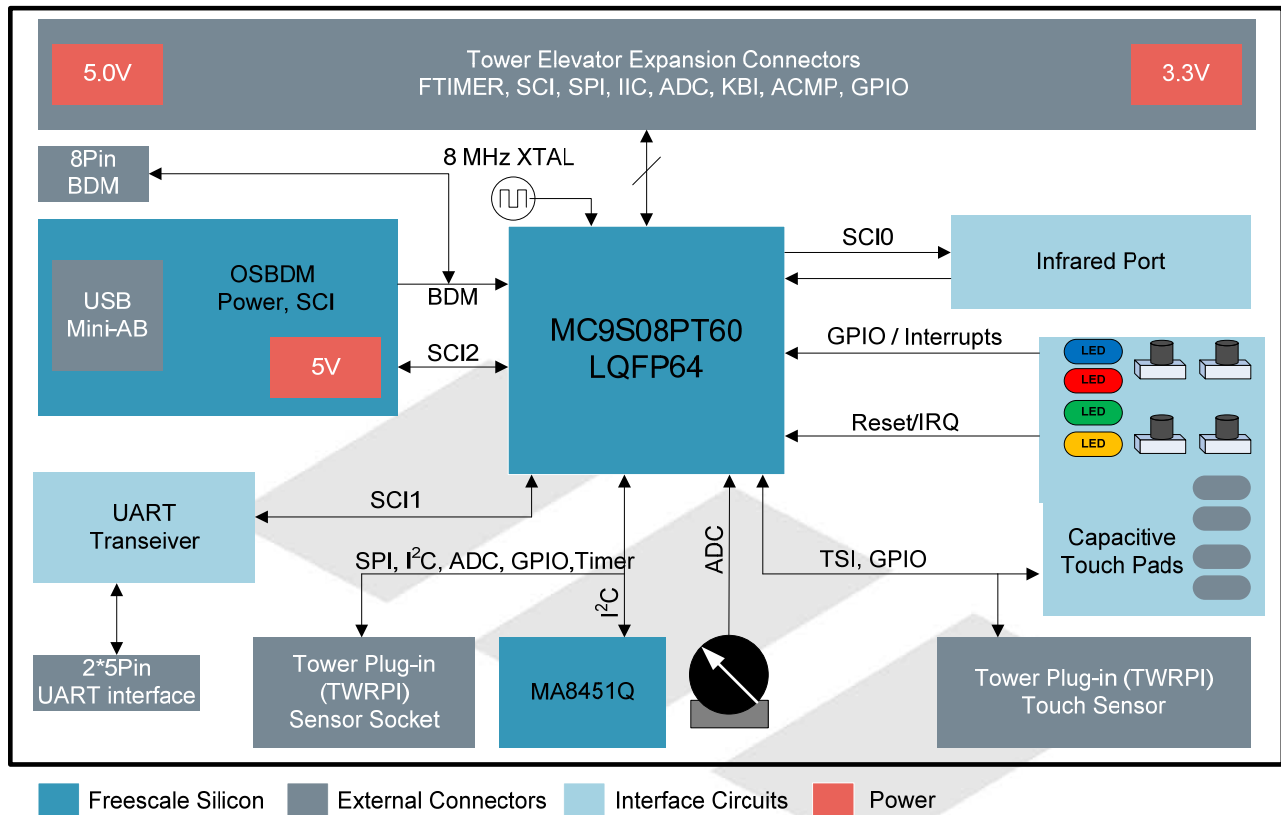

Figure 1. TWR-S08PT60 Block Diagram

2 Reference Documents

The documents listed below are available online. Refer to <http://www.freescale.com/tower> for the latest revision of all Tower System documentation.

- *TWR-S08PT60 Schematics*
- *TWR-S08PT60 Quick Start Guide*
- *TWR-S08PT60-KIT Labs Tutorial*
- *MC9S08PT60 Reference Manual*
- *MC9S08PT60 Data Sheet*
- *AN3561, USB Boot loader for the MC9S08JM60*

3 Hardware Features

This section provides more details about the features and functionality of the TWR-S08PT60.

3.1 Clocking

An 8MHz external crystal is used for the external clock source of the PT60. The clock signal can be isolated when the EXTAL and XTAL pin are used for the other purpose (GPIO, IIC).

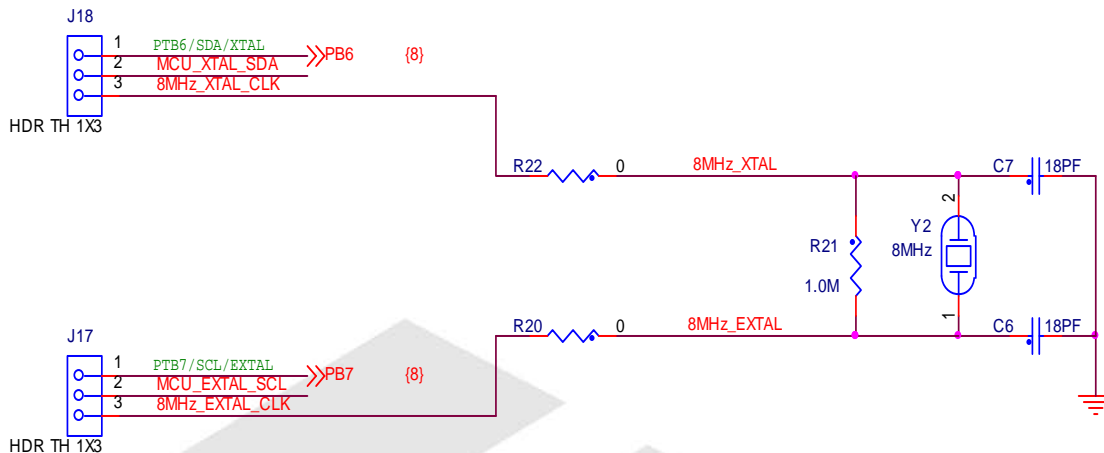

Figure 2. clock circuit

3.2 System Power

The TWR-S08PT60 can be powered by the OSBDM circuit Mini-B USB connector when running in stand-alone mode. When assembled with the Tower System, the TWR-S08PT60 is powered by the Tower System Elevators and the mini-B USB connector is no longer used as a power source and only used for OSBDM debugging purposes. In addition, the TWR-S08PT60 can also be powered by the TWRPI interface which enables the motor control board APMOTOR56F800E to power the TWR-S08PT60. In this case, J27 pin 1 and 2 must be shorted to allow 3.3V from the motor control board to power the system.

When working in standalone mode, short pin 2 and 3 on both J25 and J26 jumper blocks as the default jumper setting. When working with the Tower System, short pin 1 and 2 on both J25 and J26 jumper blocks:

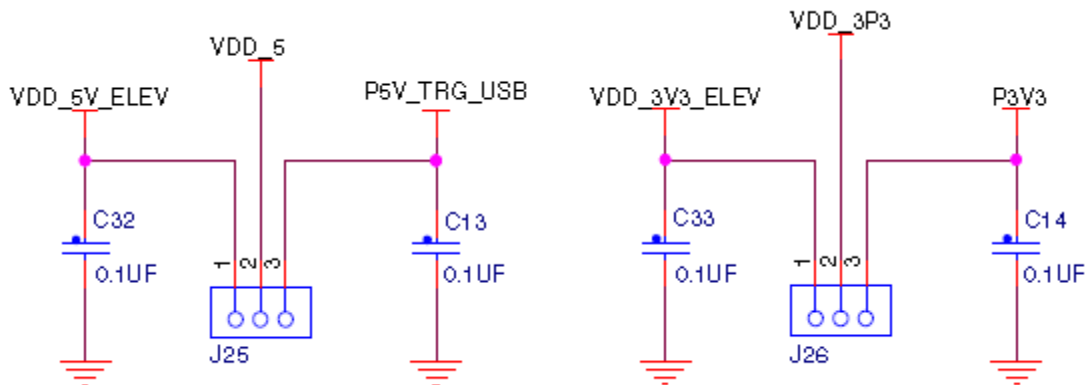

Figure 3. Power supply selection for standalone or Tower Elevator

The PT60 can be powered by 5V or 3.3V power supply which is configurable via jumper J27: to use 5V power supply, short Pin 1 and 2; to use 3.3V power supply, short Pin 2 and 3.

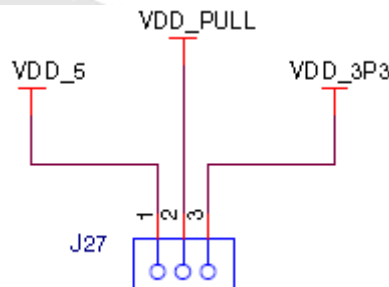

Figure 4. Power supply selection for 5V or 3.3V

In addition, the jumper J29 is provided for PT60 current measurement.

3.3 Debug Interface

An on-board, MC9S08JM60 based OSBDM circuit provides a debug interface to the MC9S08PT60. A standard USB A male to Mini-B male cable can be used for debugging and programming device via the USB connector J24. BDM interface J23 is also provided for using the external BDM multilink. To use the onboard OSBDM to debug and program the MC9S08PT60 on TWR-S08PT60, make sure J16 and J28 are both close.

The onboard OSBDM can also be used to debug and program user's target board. In this case, the system power connection must be set up per Section 3.2. In addition, both J16 and J28 must be OPEN and the debug signal connections are required as the following table:

Table 1. OSBDM to Target board connection

OSBDM	Target board
J16 pin 1	BDM connector pin 1
J28 pin 1	BDM connector pin 4
J23 pin 2	BDM connector pin 2
J23 pin 6	BDM connector pin 6

3.4 RS232 Interface

An RS232 transceiver, the ICL3232, on the TWR-S08PT60 connects to a standard 2x5 pin header J6. Selection of jumpers J1 and J2 allows MC9S08PT60 SCI2 signals to be routed to either the OSBDM or the Primary Elevator A41, A42 pin. When the SCI signals are routed to the OSBDM by installing a jumper on J1 pin 1 and 2, J2 pin 1 and 2 as the default jumper settings, the OSBDM can function as a virtual RS232 port with the help of P&E OSBDM OSJTAG Tower Toolkit (Virtual Serial Toolkit) from www.pemicro.com/osbdm.

Alternatively, when assembled as a Tower System, the MC9S08PT60 SCI1 TX and RX can be routed to the SER-TWR by J5. J5 is a stand 3x5pin header. If the SER-TWR jumpers are configured to run in RS-232 mode, the SCI1 TX and the RX signal can be communicated via the RS232 connector from the TWR-SER. Please refer to the TWE-SER user manual (TWRSERUM) from <http://www.freescale.com/tower> for more detail.

J6			
Not Connected	1	2	Not Connected
T1_OUT	3	4	R2_IN
R1_IN	5	6	T2_OUT
Not Connected	7	8	Not Connected
GND	9	10	3.3V

Figure 5. J6 Header Connections

3.5 Infrared Port

The TWR-S08PT60 implements an infrared transmit and receive port. The transmit circuit is implemented with an infrared diode which is driven by SCI0 TXD0 pin. The receiver is implemented by an infrared transistor and the user can choose to input this signal to the SCI0 RXD0 or the ACMP input. Jumper J5 is used for routing the connections, refer to Section 4 for jumper settings. Please refer to application note AN4116, searchable from www.freescale.com

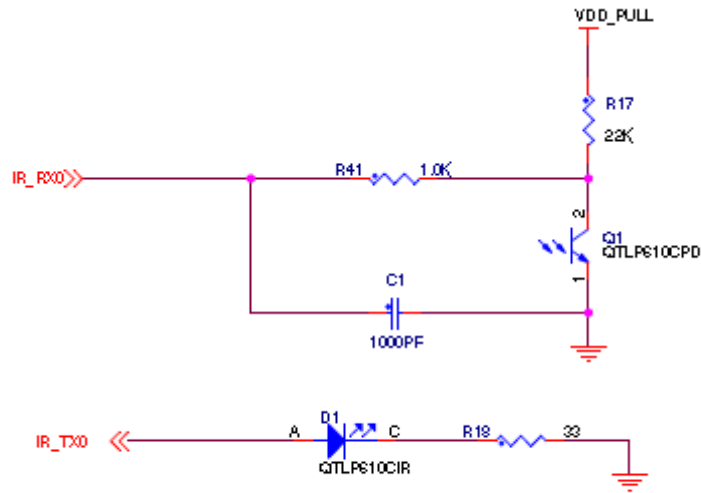

Figure 6. Infrared

3.6 Accelerometer

The MMA8451Q digital accelerometer is included on-board as below:

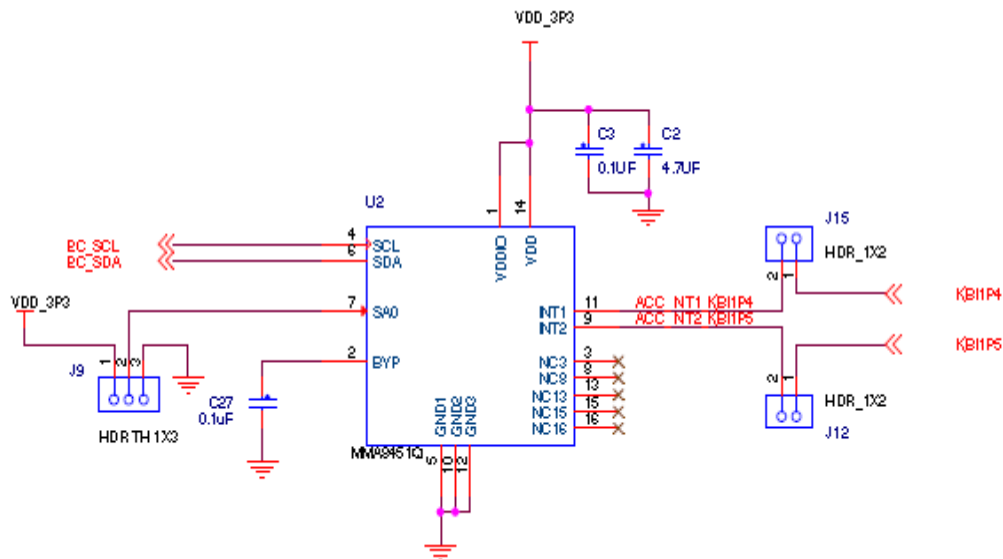

Figure 7. Accelerometer

The MMA8451Q is only powered by 3.3V and its default IIC slave address is 0x1C when the jumper J9 pin 2 and 3 are shorted. If the jumper J9 pin 1 and 2 are short, its IIC slave address is 0x1D. Two interrupt signals from MMA8451Q can be routed to KBI1P4 and KBI1P5 of PT60 via J15 and J12.

3.7 TWRPI Sockets

The TWR-S08PT60 module includes two special TWRPI sockets which can be connected to the motor control board APMOTOR56F800E and other compliant TWRPI modules. The TWR-S08PT60 provides 5V, VDDA, GND, and VSS to the TWRPI socket. The TWR-S08PT60 module can be powered from the TWRPI as described in Section 3.2 System Power.

The pin-out for the TWRPI Socket are defined as below: (for detailed signal routing, please refer to TWR-S08PT60 schematics)

Table 1. TWRPI Socket Pin-out Description

Left-side 2x10 Connector (J10)

Pin	Description
1	5V VCC
2	3.3V VCC
3	GND
4	VDDA
5	VSSA
6	VSSA
7	ADC channel 0
8	ADC channel 1
9	VSSA
10	VSSA
11	ADC channel 2
12	ADC channel 3
13	VSSA
14	VSSA
15	ACMP+
16	ACMP-
17	VSSA
18	VSSA
19	GPIO
20	GPIO

Right-side 2x10 Connector (J11)

Pin	Description
1	5V VCC
2	3.3 VCC
3	GND
4	I2C: SCL
5	I2C: SDA
6	SPI: MISO
7	SPI: MOSI
8	SPI: SS
9	SPI: CLK
10	KBI
11	KBI
12	FTM1 channel 0
13	FTM1 channel 1
14	FTM2 channel 0
15	FTM2 channel 1
16	FTM2 channel 2
17	GND
18	FTM2 channel 3
19	FTM2 channel 4
20	FTM2 channel 5

3.8 User Interfaces

The user interface includes

- Four push button switches connected to GND and KBI/RESET/Interrupt signals.

- Four LEDs driven directly by GPIO pins of the PT60.
- Touch pad interface with four onboard touch pads and a touch sensor daughter card socket connected to the PT60 TSI pins.
- A potentiometer connected to an ADC input signal. The Potentiometer output voltage is connected the ADC channel via a jumper.

3.8.1 Push buttons

There are two general purpose buttons which can be used to evaluate keyboard interrupts, and general switch input: SW2 and SW3. SW2 is connected to KBI1P5 pin of PT60 and SW3 to KBI1P4 pin of PT60.

In addition, there is a reset button (SW4) used to reset PT60 and a force BDM button (SW1) used to manually force PT60 into BDM mode upon power up or reset.

3.8.2 Touch PAD Interface

The TSI module will be used with the on-board electrodes and/or with a touch sensor daughter card. The touch sensor daughter card connector (J8) is identical to “Module ‘D’” TWR-SENSOR board which supports a total of 12 TSI signals:

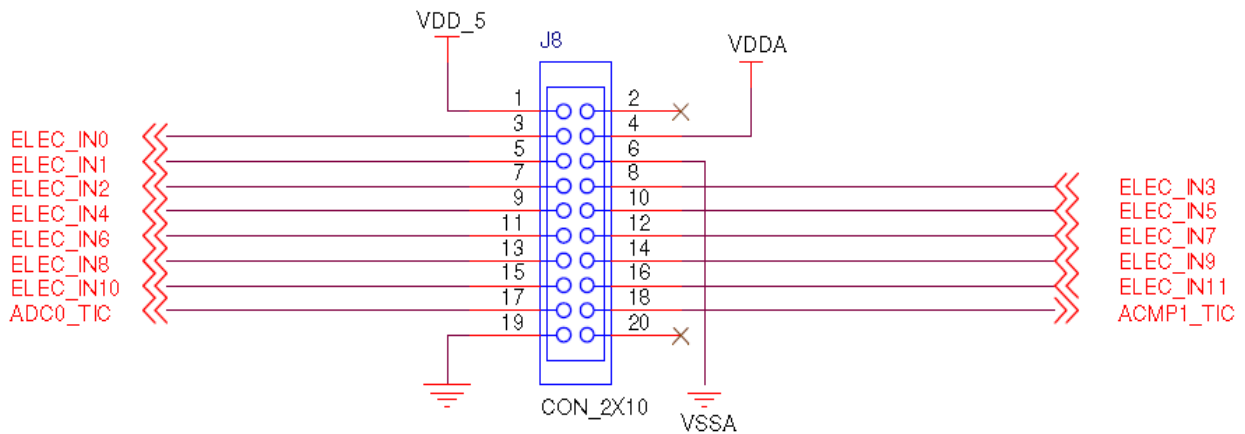

Figure 8. Touch Interface Connector

The pin-out for Socket “D” is defined as:

Table 2. D Socket Pin Description

Pin	Description
1	5V VCC
2	NC
3	Electrode 0
4	NC

5	Electrode 1
6	VSS (Analog GND)
7	Electrode 2
8	Electrode 3
9	Electrode 4
10	Electrode 5
11	Electrode 6
12	Electrode 7
13	Electrode 8
14	Electrode 9
15	Electrode 10
16	Electrode 11
17	ADC: TWRPI ID 0
18	ADC: TWRPI ID 1
19	GND
20	NA

The four on-board electrodes are placed near the edge of the MCU module, each has a hole in the center (see Figure 9). The four user-controllable LEDs are mounted on the bottom of the PCB with the lens visible through the hole in the PCB.

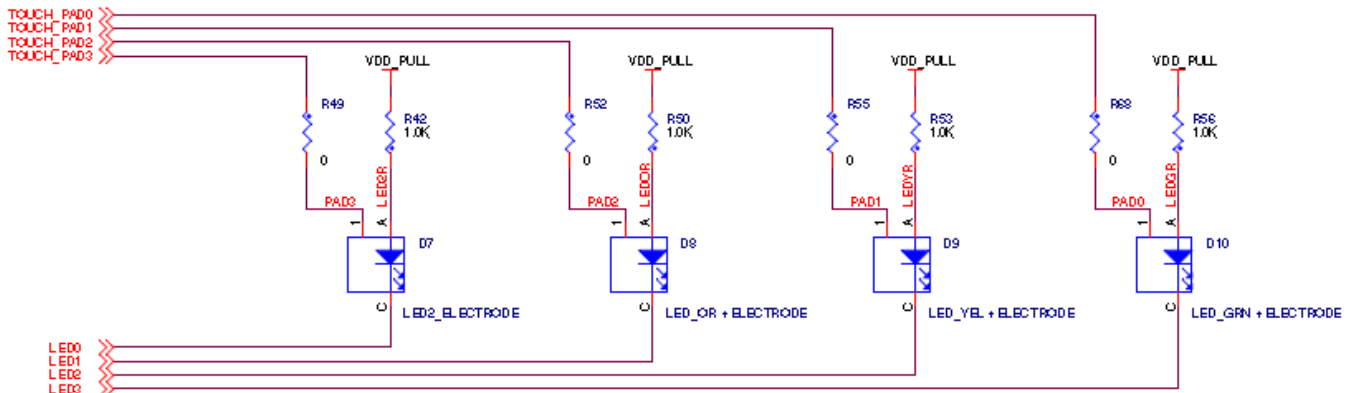

Figure 9. Onboard touch PADS and LEDs

3.8.3 Potentiometer

A potentiometer is connected to the ADC input channel ADP0 through a jumper J7 as shown in the following figure 10. It allows intuitive test of the MC9S08PT60 ADC functionality and enables fast validation of the target ADC code.

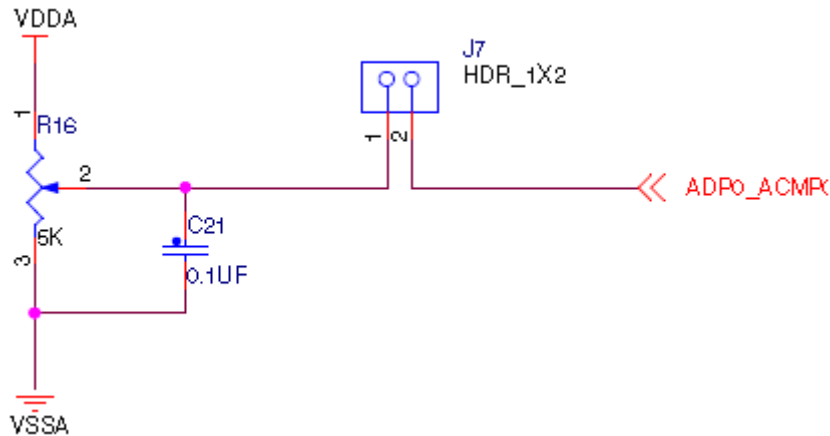

Figure 10. TWR-S08PT60 Potentiometer to ADC Input

3.9 Elevator Connections

The TWR-S08PT60 features two expansion card-edge connectors that interface to elevator boards in a Tower System: the Primary and Secondary Elevator connectors. The Primary Elevator connector, comprised of sides A and B, is utilized by the TWR-S08PT60, while the Secondary Elevator connector only makes connections to the powers and ground (GND). Figure 11 provides the pin-out for the Primary Elevator connector. An “X” in the “Used” column indicates that there is a connection from the TWR-S08PT60 to that pin on the elevator connector. An “X” in the “Jmp” column indicates that a jumper is available that can configure or isolate the connection from the elevator connector.

Figure 11. TWR-S08PT60 Primary Elevator Connector Pin-out

TWR-S08PT60 Primary Connector									
Pin	Name	Usage	Used	Jmp	Pin	Name	Usage	Used	Jmp
B1	5V	5V Power	X		A1	5V	5V Power	X	
B2	GND	Ground	X		A2	GND	Ground	X	
B3	3.3V	3.3V Power	X		A3	3.3V	3.3V Power	X	
B4	ELE_PS_SENSE	Elevator power sense	X		A4	3.3V	3.3V Power	X	
B5	GND	Ground	X		A5	GND	Ground	X	
B6	GND	Ground	X		A6	GND	Ground	X	
B7	SPI1_CLK	SPI1 clock	X		A7	SCL0	IIC clock	X	
B8	SPI1_CS1				A8	SDA0	IIC data	X	
B9	SPI1_CS0	SPI1 chip select	X		A9	GPIO9 / OPEN	GPIO PTE6	X	
B10	SPI1_MOSI	SPI1 MOSI	X		A10	GPIO8 / OPEN	GPIO PTE5	X	
B11	SPI1_MISO	SPI1 MISO	X		A11	GPIO7 / OPEN			
B12	ETH_COL				A12	ETH_CRS			
B13	ETH_RXER				A13	ETH_MDC			
B14	ETH_TXCLK				A14	ETH_MDIO			
B15	ETH_TXEN				A15	ETH_RXCLK			

TWR-S08PT60 Primary Connector

Pin	Name	Usage	Used	Jmp	Pin	Name	Usage	Used	Jmp
B16	ETH_TXER				A16	ETH_RXDV			
B17	ETH_TXD3				A17	ETH_RXD3			
B18	ETH_TXD2				A18	ETH_RXD2			
B19	ETH_TXD1				A19	ETH_RXD1			
B20	ETH_TXD0				A20	ETH_RXD0			
B21	GPIO1 / OPEN	GPIO PTH7	X		A21	SSI_MCLK			
B22	GPIO2 / OPEN	GPIO PTH6	X		A22	SSI_BCLK			
B23	GPIO3 / OPEN	GPIO PTH1	X		A23	SSI_FS			
B24	CLKIN0	PTE7/TCLK2	X		A24	SSI_RXD			
B25	CLKOUT1	PTH2/BUSOUT	X		A25	SSI_TXD			
B26	GND	Ground	X		A26	GND	Ground	X	
B27	AN7	ADC channel 1	X		A27	AN3	ADC channel15	X	
B28	AN6	ADC channel 0	X		A28	AN2	ADC channel14	X	
B29	AN5	ADC channel 7	X		A29	AN1	ADC channel13	X	
B30	AN4	ADC channel 6	X		A30	AN0	ADC channel12	X	
B31	GND	Ground	X		A31	GND	Ground	X	
B32	DAC1	FTM0 channel 1	X		A32	DAC0	FTM1 channel1	X	
B33	TMR3				A33	TMR1	FTM1 channel 1	X	
B34	TMR2	FTM0 channel 1	X		A34	TMR0	FTM1 channel 0	X	
B35	GPIO4				A35	GPIO6	GPIO PTE4	X	
B36	3.3V	3.3V Power	X		A36	3.3V	3.3V Power	X	
B37	PWM7				A37	PWM3	FTM2 channel 3	X	
B38	PWM6		X		A38	PWM2	FTM2 channel 2	X	
B39	PWM5	FTM2 channel 5	X		A39	PWM1	FTM2 channel 1	X	
B40	PWM4	FTM2 channel 4	X		A40	PWM0	FTM2 channel 0	X	
B41	CANRX0				A41	RXD0	SCI2 receive	X	X
B42	CANTX0				A42	TXD0	SCI2 transmit	X	X
B43	1WIRE				A43	RXD1	SCI1 receive	X	X
B44	SPI0_MISO	SPI0 MISO	X		A44	TXD1	SCI1 transmit	X	X
B45	SPI0_MOSI	SPI0 MOSI	X		A45	VSSA	Analog VSSAD/VREFL	X	
B46	SPI0_CS0	SPI0 Chip Select	X		A46	VDDA	Analog VDDAD/VREFH	X	
B47	SPI0_CS1				A47	CAN1_RX			
B48	SPI0_CLK	SPI0 clock	X		A48	CAN1_TX			
B49	GND	Ground	X		A49	GND	Ground	X	
B50	SCL1	IIC clock	X	X	A50	GPIO14			
B51	SDA1	IIC data	X	X	A51	GPIO15			
B52	GPIO5 / OPEN	GPIO PTH0	X		A52	GPIO16			
B53	USB0_DP_PDOWN				A53	GPIO17			
B54	USB0_DM_PDOWN				A54	USB0_DM			
B55	IRQ_H				A55	USB0_DP			
B56	IRQ_G				A56	USB0_ID			
B57	IRQ_F	KBI1P5	X		A57	USB0_VBUS			
B58	IRQ_E				A58	TMR7			
B59	IRQ_D	IRQ pin	X		A59	TMR6			

TWR-S08PT60 Primary Connector									
Pin	Name	Usage	Used	Jmp	Pin	Name	Usage	Used	Jmp
B60	IRQ_C				A60	TMR5			
B61	IRQ_B	KBI1P4	X		A61	TMR4			
B62	IRQ_A	ADC channel 2/GPIO PTA6	X		A62	RSTIN_b			
B63	EBI_ALE / EBI_CS1_b				A63	RSTOUT_b	RESET	X	
B64	EBI_CS0_b				A64	CLKOUT0			
B65	GND	Ground	X		A65	GND	Ground	X	
B66	EBI_AD15				A66	EBI_AD14			
B67	EBI_AD16				A67	EBI_AD13			
B68	EBI_AD17				A68	EBI_AD12			
B69	EBI_AD18				A69	EBI_AD11			
B70	EBI_AD19				A70	EBI_AD10			
B71	EBI_R/W_b				A71	EBI_AD9			
B72	EBI_OE_b				A72	EBI_AD8			
B73	EBI_D7				A73	EBI_AD7			
B74	EBI_D6				A74	EBI_AD6			
B75	EBI_D5				A75	EBI_AD5			
B76	EBI_D4				A76	EBI_AD4			
B77	EBI_D3				A77	EBI_AD3	PTG3	X	
B78	EBI_D2				A78	EBI_AD2	PTG2	X	
B79	EBI_D1				A79	EBI_AD1	PTG1	X	
B80	EBI_D0				A80	EBI_AD0	PTG0	X	
B81	GND	Ground			A81	GND	Ground	X	
B82	3.3V	3.3V Power			A82	3.3V	3.3V Power	X	

3.10 Mechanical Form Factor

The TWR-S08PT60 is designed for the Freescale Tower System and complies with the electrical and mechanical specification as described in *Freescale Tower Electromechanical Specification*.

4 Jumper Table

There are several jumpers provided for isolation, configuration, and feature selection. Refer to the following table for details.

Figure 12. TWR-S08PT60 Jumper Table

Jumper	Option	Setting	Description of MC9S08PT60 signal routing
J1	UART2 selection	1-2	Connect RXD2 to OSBDM UART RX
J2	UART2 selection	1-2	Connect TXD2 to OSBDM UART TX
J3	ACMP1 selection	1-2	ACMP1 connect to Touch pad TWRPI pin18 of J8
		2-3	ACMP1 optionally connected to Motor control TWRPI pin15 of J10
J4	UART transceiver loop	1-2	U1 pin9 and pin10 is shorted.
J5	UART/TSI/IRDA selection	1-2	UART1 TXD signal is connected to primary elevator A44
		2-3	UART1 TXD signal is connected to U1 pin11
		4-5	UART1 RXD signal is connected to primary elevator A43
		5-6	UART1 TXD signal is connected to U1 pin12
		7-8	PTB0/KBIOP4/RXD0/ADP4/TSI2 pin is connected to pin3 of J8
		8-9	PTB0/KBIOP4/RXD0/ADP4/TSI2 pin is connected to IRDA RX
		10-11	PTB1/KBIOP5/TXD0/ADP5/TSI3 pin is connected to pin5 of J8
		11-12	PTB1/KBIOP5/TXD0/ADP5/TSI3 pin is connected to IRDA TX
		13-14	Open
J7	PTA0/KBIOP0/FTM0CH0/ACMP0/ADP0 pin selection	1-2	Potentiometer is connected to PTA0/KBIOP0/FTM0CH0/ACMP0/ADP0 pin
		1-2	Slave Address (SA0 = 1) 0011101 (0x1D)
J9		2-3	Slave Address (SA0 = 0) 0011100 (0x1C)
		1-2	KBIP4 pin(PT60 pin44) is connected to U2 pin11
J12		1-2	KBIP4 pin(PT60 pin44) is connected to U2 pin11
J13	OSBDM Boot loader mode or debugger mode selection	1-2	OSBDM IC in boot loader mode(For OSBDM firmware reprogramming)
		Open	OSBDM IC in debugger mode
J15	KBIP4 pin selection	1-2	KBIP4 pin(PT60 pin44) is connected to U2 pin11
J20	FTM2CH0 or TSI6 function selection	1-2	PTC0/FTM2CH0/ADP8/TSI6 pin is connected to pin9 of J8
		2-3	PTC0/FTM2CH0/ADP8/TSI6 pin is connected to pin14 of J11

J21	FTM2CH1 or TSI7 function selection	1-2	PTC1/FTM2CH1/ADP9/TSI7 pin is connected to pin10 of J8
		2-3	PTC1/FTM2CH1/ADP9/TSI7 pin is connected to pin15 of J11
J22	ADP15 pin selection	1-2	ADP15 pin is connected to pin 7 of J8
		2-3	ADP15 pin is connected to pin 17 of J8
J25	VDD_5 selection	1-2	Elevator +5V is connected to VDD_5V
		2-3	USB +5V is connected to VDD_5V
J26	VDD_3P3 selection	1-2	Elevator +3.3V is connected to VDD_3P3
		2-3	LDO U4 output voltage +3.3V is connected to VDD_3P3
J27	VDD_PULL selection	1-2	VDD_PULL is connected to +5V
		2-3	VDD_PULL is connected to +3.3V
J28	Reset signal for MC9S08PT60	1-2	Reset signal is connected to RESET pin
J29	MC9S08PT60 Power supply	1-2	VDD is connected to VDD_PULL

NOTE: For more detail, please refer to TWR-S08PT60 schematics available in the TWR-S08PT60-KIT or on www.freescale.com/tower.

5 Input/Output Connectors and Pin Usage Table

The following tables provide details on which MC9S08PT60 pins are communicating with the sensors, LEDs, switches and other I/O interfaces.

Figure 13. I/O Connectors and Pin Usage Table

TWR-S08PT60		MC9S08PT60				
I/O Component	I/O Label	Default	Alt 1	Alt 2	Alt 3	Alt4
Push Button	SW1	PTA4	-	ACMPO	BKGD	MS
	SW2	PTD5	KBI1P5	-	-	-
	SW3	PTD4	KBI1P4	-	-	-
	SW4	PTA5	IRQ	TCLK0	-	/RESET
Touch Pad	PAD0	PTF3	-	-	-	TSI15
	PAD1	PTF2	-	-	-	TSI14
	PAD2	PTA7	FTM2FAULT2	-	ADP3	TSI1
	PAD3	PTA6	FTM2FAULT1	-	ADP2	TSI0
LED	LED0 (D7)	PTG0	-	-	-	-
	LED1(D8)	PTG1	-	-	-	-
	LED2(D9)	PTG2	-	-	-	-
	LED3(D10)	PTG3	-	-	-	-
Accelerometer MMA8451Q	SCL	PTA3	KBIOP3	TXD0	SCL	-
	SDA	PTA2	KBIOP2	RXD0	SDA	-
	INT1	PTD4	KBI1P4	-	-	-
	INT2	PTD5	KBI1P5	-	-	-
Potentiometer	R16	PTA0	KBIOP0	FTMOCH0	ACMPO	ADPO
UART	SCIO_TX	PTC7	-	TXD1	-	TSI9
	SCIO_RX	PTC6	-	RXD1	-	TSI8

6 OSBDM

An on-board, MC9S08JM60-based OSBDM circuit provides a debug interface to the MC9S08PT60. It can also function as a virtual RS232 port as described in Section 3.4 RS232 Interface.

The MC9S08JM60 is a USB-enabled microcontroller with an 8-bit S08 core. The OSBDM circuit provides a USB-to-debug interface that allows run-control and debugging of the MC9S08PT60 devices on the TWR-S08PT60 Tower System module or on the user's target boards. For more information on how to configure jumpers for the OSBDM to support user's target board, please consult Section 3.3 Debug Interface.

The USB drivers required to communicate with the OSBDM are provided in development tools, such as Freescale CodeWarrior software. www.freescale.com/codewarrior

When TWR-S08PT60 is used stand-alone, this single USB connection can also be used to power the board.

6.1 Bootloader Mode For MC9S08JM60

The MC9S08JM60 device used in the OSBDM circuit is preprogrammed with OSBDM debugger firmware and a USB Bootloader. The bootloader mode can be used to update the OSBDM debugger firmware if an update becomes available. Jumper J13 determines which application will run following a power-on reset. If the Bootloader Mode is chosen (jumper shunt on J13), the bootloader will be executed, allowing in-circuit reprogramming of the JM60 Flash memory via USB. Refer to [Application Note AN3561](#) on the Freescale website (<http://www.freescale.com>) for details on the USB Bootloader.

The USB Bootloader communicates with a GUI application running on a host PC. The GUI application can be found on the [Freescale website](#); search keyword "JM60 GUI." Refer to section 2.5 and 3.3 of AN3561 for details on installing and running the application.

Note:

The JM60 GUI Installer should run before connecting the OSBDM in Bootloader Mode to a host USB port. Otherwise, the JM60 USB device will not be recognized and the proper drivers will not be loaded.

7 BDM Interface (Optional)

Both MC9S08PT60 and MC9S08JM60 have an on-chip background debug module. The user can choose to bypass the USB OSBDM interface and use the BDM interface for debugging and programming the corresponding chip instead. The BDM interface for MC9S08PT60 is at J23 header and MC9S08JM60 is at J19 from the TWR-S08PT60 module. The user needs a P&E USB BDM MULTILINK in order to use this interface. This is a repeat function of the OSBDM and is not required.

Information in this document is provided solely to enable system and software implementers to use Freescale Semiconductor products. There are no express or implied copyright licenses granted hereunder to design or fabricate any integrated circuits or integrated circuits based on the information in this document.

Freescale Semiconductor reserves the right to make changes without further notice to any products herein. Freescale Semiconductor makes no warranty, representation, or guarantee regarding the suitability of its products for any particular purpose, nor does Freescale Semiconductor assume any liability arising out of the application or use of any product or circuit, and specifically disclaims any liability, including without limitation consequential or incidental damages. "Typical" parameters that may be provided in Freescale Semiconductor data sheets and/or specifications can and do vary in different applications and actual performance may vary over time. All operating parameters, including "Typicals," must be validated for each customer application by customer's technical experts. Freescale Semiconductor does not convey any license under its patent rights nor the rights of others.

Freescale Semiconductor products are not designed, intended, or authorized for use as components in systems intended for surgical implant into the body, or other applications intended to support or sustain life, or for any other application in which failure of the Freescale Semiconductor product could create a situation where personal injury or death may occur. Should Buyer purchase or use Freescale Semiconductor products for any such unintended or unauthorized application, Buyer shall indemnify Freescale Semiconductor and its officers, employees, subsidiaries, affiliates, and distributors harmless against all claims, costs, damages, and expenses, and reasonable attorney fees arising out of, directly or indirectly, any claim of personal injury or death associated with such unintended or unauthorized use, even if such claims alleges that Freescale Semiconductor was negligent regarding the design or manufacture of the part.

RoHS-compliant and/or Pb-free versions of Freescale products have the functionality and electrical characteristics as their non-RoHS-complaint and/or non-Pb-free counterparts.

For further information, visit freescale.com or contact your Freescale sales representative.

For information on Freescale's Environmental Products program, visit freescale.com/epp.

X-ON Electronics

Largest Supplier of Electrical and Electronic Components

Click to view similar products for [Development Boards & Kits - S08/S12 category](#):

Click to view products by [NXP manufacturer](#):

Other Similar products are found below :

[S12ZVML12EVBLIN](#) [TWR-S12G240-KIT](#) [TWR-S12G64-KIT](#) [DEMO9S08JS16](#) [S12ZVMC12EVBCAN](#) [S08SU16-EVK](#) [S12ZVM32EVB](#)
[S12ZVMC256EVB](#) [DEMO9S12XDT512E](#) [TWR-S12GN32-KIT](#) [DEMO9S08DZ60](#) [DEVKIT-S12VR64](#) [DEVKIT-S12VRP](#) [DEVKIT-](#)
[S12ZVC](#) [DEVKIT-ZVL128](#) [MTRCKTSPNZVM128](#) [S08PB16-EVK](#) [S08PT60-EVK](#) [S12ZVMAEVB](#) [S12ZVM-EFP](#) [TRK-S12VR-WLFT](#)
[S12VR32EVB](#) [TRK-S12ZVL](#)