



COMPASS™ CX SERIES

Portable Scales



Energy-Efficient Portable Scale Suitable for Workplace and in-the-Field Weighing

Designed with energy efficiency in mind, the Compass CX series offers a battery life of up to **1,000 continuous hours**, allowing for uninterrupted operation. Featuring a slim, stackable and light-weight design, the CX fits ideally in lab, industrial, education, and even household settings. The streamlined two-button operation means that the balance can be operated easily, and large backlit LCD display enables easy viewing of weighing results.

Standard Features:

- Alkaline batteries provide up to **1,000 hours of continuous use**, making for energy efficient weighing in the workplace, classroom, etc.
- Large backlit display increases readability in low-light conditions and makes it easier to view results from a distance.
- Slim, space-saving design allows for stackable storage for up to four scales.

COMPASS™ CX SERIES Portable Scales

Model	CX221	CX621	CX1201	CX2200	CX5200
Capacity (g)	220	620	1200	2200	5200
Readability (g)	0.1			1	
Span Calibration Mass (Not Included)	200 g	500 g	1 kg		2 kg
Stabilization Time(s)	1.5		2	1.5	
Construction	ABS housing and stainless steel pan				
Calibration	User-selectable external span / Digital with external weight				
Tare Range	Full capacity by subtraction				
Weighing Units*	g, N, oz, lb:oz				
Application Modes	Weighing				
Power Requirement	3 AA batteries (included) or AC adapter (not included)				
Typical Battery Life	1,000 hours				
Display Type	Liquid crystal display (LCD) with backlight				
Display Size	18 mm				
Pan Size (W × D)	128 × 142 mm				
Balance Dimensions (W × D × H)	135 × 201 × 41 mm				
Shipping Dimensions (W × D × H)	170 × 235 × 55 mm				
Net Weight	0.5 kg				
Shipping Weight	0.7 kg				

*Availability is dependent on model.

Other Standard Features and Equipment

ABS housing, slip-resistant feet, stability indicator, mechanical and software overload/underload protection, low battery indicator, auto shut-off

Compliance

- **Product Safety:** IEC/EN 61010-1
- **Electromagnetic Compatibility:** IEC/EN 61326-1 Class B, Basic environments; FCC Part 15 Class B; Canada ICES-003 Class B
- **Compliance Marks:** CE; RCM

Accessories

Carrying Case.....	30467763
Bowl, 1050 mL.....	80850075
Adapter, 5V 1A EU, fixed plug.....	30333866
Adapter, 5V 1A UK, fixed plug.....	30333867

Dimensions

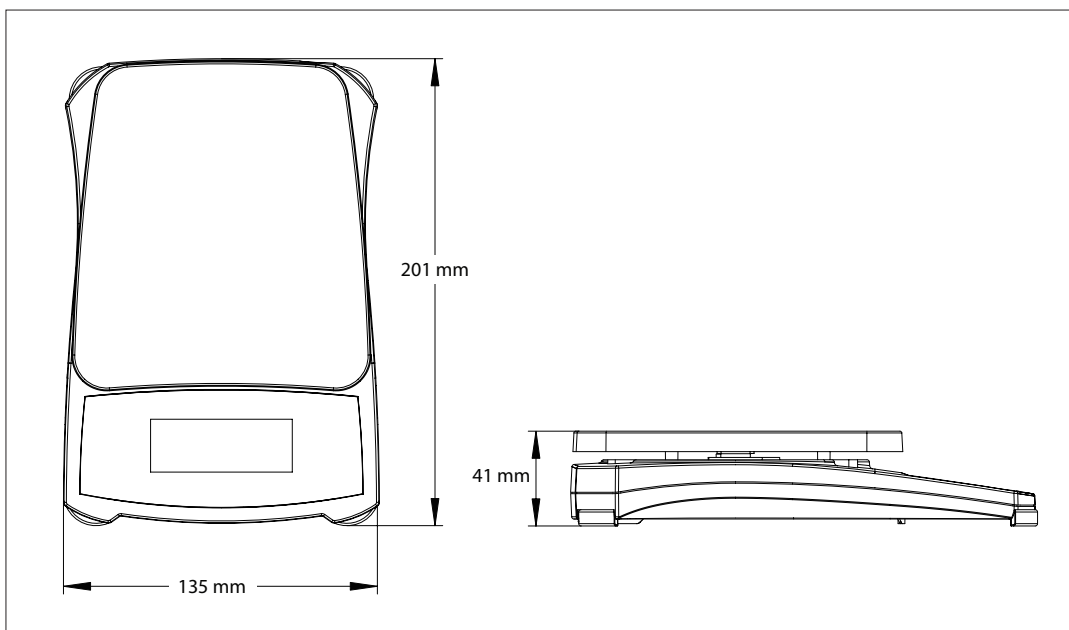

OHAUS Europe GmbH

Heuwinkelstrasse
8606 Naenikon
Switzerland

e-mail: ssc@ohaus.com
Tel: 0041 22 567 53 19
e-mail: tsc@ohaus.com
Tel: 0041 22 567 53 20

www.ohaus.com

The management system governing the manufacture of this product is ISO 9001:2015 certified.

Europe Literature #



X-ON Electronics

Largest Supplier of Electrical and Electronic Components

Click to view similar products for [Ohaus](#) manufacturer:

Other Similar products are found below :

[DISCRETE I/O KIT](#) [D22M300BXZ-M](#) [83032109](#) [SD200L](#) [83032108](#) [30037449](#) [11117004](#) [87000009](#) [NVT6201](#) [NVT6400M](#) [CR2200](#)
[CR221](#) [CR621](#) [CX2200](#) [SD SD75L](#) [30037447](#) [83032107](#) [CX221](#) [CX621](#) [NV1201](#) [30037448](#) [NVT12000](#) [CR5200](#) [NVT6200](#)