



The Only Scale in its Class with Touchless Sensors That Free Up Your Hands!

OHAUS raises the bar in value-oriented scales...again! The Navigator™ series offers a unique combination of features, including touchless sensors, ultra-fast response time and superior overload protection for use in a wide variety of weighing applications.

Standard Features Include:

- **Touchless Sensors** – Navigator is designed with two touchless sensors that will free up your hands so you can focus on handling samples. The touch-free control of the zero, print, function or tare operations helps to avoid transferring sample residue to the keypad. In addition, the two sensors can be set up independently to control up to 36 combinations of operations.
- **One Second Stabilization Time** – Navigator is designed to accurately stabilize in less than one second to provide fast and accurate weighing results, improving operator efficiency, productivity and throughput.
- **Superior Overload Protection** – Navigator is designed with a superior mechanical overload protection system that allows the scale to withstand loads up to 400% of its rated capacity. This prevents damage to the scale and helps it withstand undue shock or overloading. In addition, an integrated shipping lock further protects the weighing cell from damage during transportation or storage.
- **LCD or LED Display Options** – Navigator is designed with LCD or LED displays to provide the best visibility in any lighting condition. Whether you use the Navigator indoor or outdoor, the display is also designed with large numeric segments and unit indicators to make the weighing results easy to read.

Navigator™ Portable Scales

With its best-in-class combination of features, versatility and performance, the OHAUS Navigator offers a wide range of use in industrial, food and laboratory weighing applications.

Unsurpassed Cleanliness

- Designed with two touchless sensors that free up your hands, allowing you to focus on handling samples and keeping the scale free from contaminants. The touch-free control of tare, zero, print, function and display backlight helps to minimize touching the keypad, thereby avoiding cross-contamination or unwanted residue on or from the scale.
- A polished stainless steel pan, corrosion-free plastic housing and spill-resistant pan sub-assembly embodies a hygienic design that is easy to clean.
- The optional full-body in-use cover wraps over and around the housing and keypad to guard against spills, dust and contamination.

Unmatched Productivity

- Stabilizes in less than one second to provide fast, accurate and repeatable weighing results. This helps improve operator efficiency and increase productivity.
- The optional internal rechargeable lead acid battery can operate LCD versions up to 100 hours (or over twelve 8-hour days) of normal use on a full charge. With maximized portability, the scale can be transported and used where power outlets are not readily available. The rechargeable battery also helps minimize battery replacement and maintenance costs.
- A wave of the hand over the touchless sensors eliminates the extra effort or time to press the keys, which helps increase convenience and efficiency.
- A bright backlit LCD or LED display provides optimum visibility in any lighting condition – indoors or out – with large digits and indicators that make it fast and easy to read the weighing results.

Unbeatable Durability

- Built to hold up to serious loads, the superior mechanical overload protection system enables the scale to safely bear loads up to 4 times its rated capacity.
- Constructed of a high-strength 304 type stainless steel pan and impact-resistant ABS plastic housing that helps the scale stand up to years of use or abuse.
- The touchless sensors minimize the need to press the keypad with your hand, a knife or other sharp objects, reducing wear and tear of the keypad and increasing the effective life of the scale.



Navigator XT with LED display



Navigator XL with LCD display



Navigator with square pan and LED display



Navigator with round pan and LCD display

Features

Optional Internal Rechargeable Battery

Enhance mobility by being able to work anywhere! The sealed lead acid battery minimizes battery replacement and reduces maintenance costs.



Multiple Application Modes

Navigator is designed for versatility. Multiple application modes such as: counting, percent weighing, checkweighing, display hold and accumulation/totalization address a wide range of use in quality control, inventory management, shipping and receiving, recipes and for formulation, portioning and other popular

Available RS232, USB or Ethernet Interface Kits

These easily installed user options allow connecting the scale to peripheral devices for printing and/or data collection. The connecting cable is integrated in each kit, eliminating the need for additional interface cables.



Backlit Display

The bright backlit LED or LCD provides optimal visibility in any lighting condition. Used indoors or outdoors, the large digits and indicators also make the weighing results fast and easy to read.



Transportation Lock

The transportation lock prevents undue pressure on the load cell to ensure the scale is received in operational condition. Unlock before use and lock when moving around different locations.

Skid-Resistant Leveling Feet

Independently adjustable, the feet also have skid-resistant rubber pads to provide superior stability, and help prevent damage from slipping or falling over a

Touchless Sensors

Two touchless sensors can be set up independently to operate up to 36 combinations of operations without touching the keys. Prolongs the life of the keys and keeps the scale clean. Sensors control: Tare, Zero, Print, Function and Display Backlight.

Menu Lock Switch

A menu lock switch acts as an extra supervisor control to prevent unwanted changes to protected scale settings. Simply set up the scale to meet your specific needs then slide the lock switch to avoid



Illuminated Up-front Level Indicator

The integral level bubble is illuminated at power up to aid in visibility, and serves as a reminder to level



EC Type Approved models

For legal for trade or applications requiring approval, Navigator and Navigator XT include EC type approved models (Class III)

Outline Dimensions

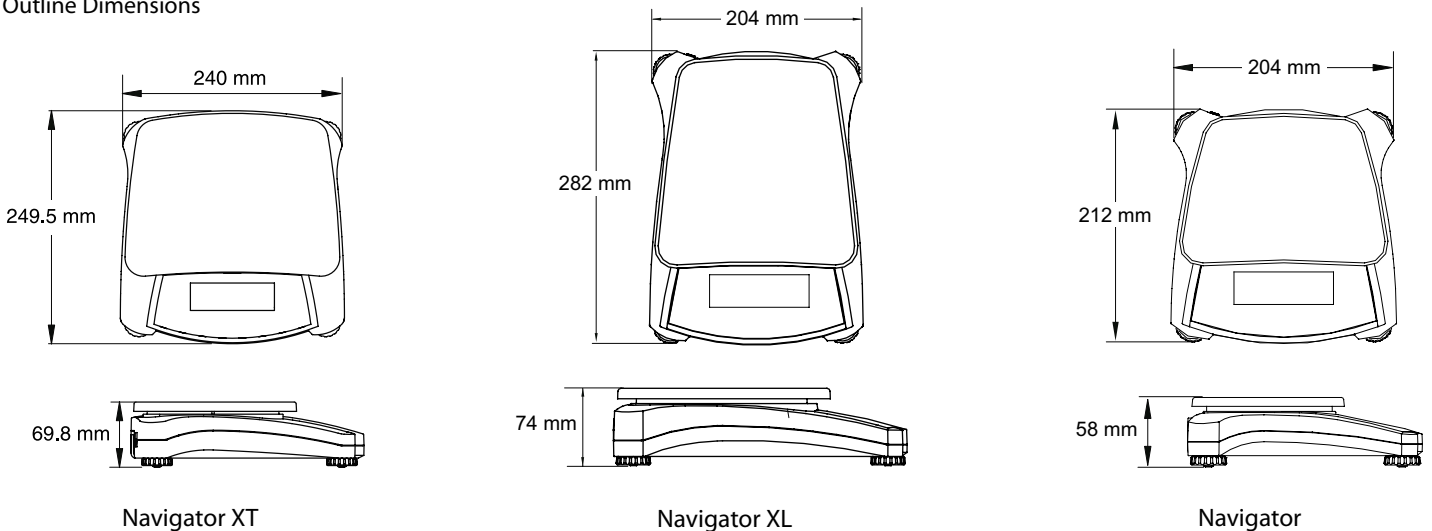

Applications

Laboratory and Research

Designed to be easy to clean, precise and simple to use in laboratory environments. Simple set up, a spill-resistant housing, percent weighing mode and security features make this the ideal solution for laboratory applications such as formulation, quality inspections, testing and experimentation.



Industry and Manufacturing

Designed to be robust, fast and accurate for ideal use in light-medium duty industrial applications, including paint and ink mixing, packaging, sampling and parts counting. Up to 400% safe overload enhances protection of internal components, with an ultra-fast, one-second stabilization time to improve operator efficiency and productivity.

Home Office, Commercial Business and Manufacturing

Designed to be tough, portable and reliable for ideal use in shipping and receiving, home office and warehouse environments. A display hold mode holds the weight for viewing that would otherwise be blocked by oversized packages. Battery operation, counting and checkweighing modes also expand range of use for hobbies, inventory management, inspection and quality control. In addition, the Navigator and Navigator XT are available EC Type approved (Class III) for commercial business or any applications requiring approval.



Food and Portioning

Designed to be hygienic, low-maintenance and durable for ideal use in food service, portioning and pre-packaging. Weighing units such as lb, oz, lb:oz (including 1/8 fractional ounce), kg and g, and percent and checkweighing modes enhance its usefulness in behind-the-counter, prep station and kitchen environments.

General Specifications – Navigator, Navigator XL, Navigator XT

Stabilization Time	≤1 second
Tare Range	Full capacity by subtraction
AC Power	12VDC 0.42A AC adapter (included), 100-240V 0.25A 50-60Hz
Calibration	User-selectable external span or linearity calibration / Digital with external weight
Operating Humidity Range	20% to 85%
Display Type	LCD: 6-digit 7-segment with white LED backlight / LED: 6-digit 7-segment
Display Size	20 mm digits
Checkweigh Indicators	Over-Accept-Under LCD or LED annunciators
Keypad	4 mechanical keys, raised and with tactile feedback plus 2 touchless sensors
Leveling Adjustment	Front-mounted level bubble with illumination / adjustable leveling feet with skid-resistant rubber pads
Overload Capacity	400% of rated capacity
Power Conservation	User-enabled auto power-off after 5 minutes of inactivity
Storage Conditions	-20°C to 55°C at 10% to 90% relative humidity, non-condensing.

Standard Models – Navigator XT

Models ¹	NVT1601	NVT3201	NVT6401	NVT10001	NVT16000	NVT1601M	NVT3200M	NVT6400M	NVT16000M
Capacity	1600 g	3200 g	6400 g	10000 g	16000 g	1600 g	3200 g	6400 g	16000 g
Readability	0.1 g	0.2 g	0.5 g	0.5 g	1 g	0.5 g	1 g	2 g	5 g
Verification Interval	N/A	N/A	N/A	N/A	N/A	0.5 g	1 g	2 g	5 g
Repeatability	0.1 g	0.2 g	0.5g	0.5 g	1 g	0.5 g	1 g	2 g	5 g
Linearity	±0.2 g	±0.4 g	±1 g	±1 g	±2 g	±0.5 g	±1 g	±2 g	±5 g
Span Calibration Mass	1 kg	2 kg	5 kg	5 kg	10 kg	1 kg	2 kg	5 kg	10 kg
Linearity Calibration Mass	1 kg, 1.5 kg	2 kg, 3 kg	3 kg, 6 kg	5 kg, 10 kg	10 kg, 15 kg	1 kg, 1.5 kg	2 kg, 3 kg	3 kg, 6 kg	10 kg, 15 kg
Application Modes	Weighing, Percent Weighing, Parts Counting, Check Weighing, Display Hold, Accumulate/Totalize								
Weighing Units	Gram, Kilogram, Pound, Ounce (decimal or fractional), Pound:Ounce (decimal or fractional), Ounce Troy, Grain, Newton, Carat, Pennyweight, Hong Kong Tael, Taiwan Tael, Singapore Tael, Tical, Tola					Gram, Kilogram			
Pan Size (W x D)	230 x 174 mm								
Scale Dimensions (W x D x H)	240 x 250 x 70 mm								
Shipping Dimensions (W x D x H)	385 x 335 x 170 mm								
Net Weight ²	1.5 kg								
Shipping Weight ²	2.3 kg								
Operating Temperature Range	10°C to 40°C					0°C to 40°C			
Battery Power	4 C (LR14) batteries (not included) or Internal rechargeable lead acid battery (optional), 6V1.2AH								
Ingress Protection	IP43								

Standard Models – Navigator XL

Model ¹	NVL511	NVL1101	NVL2101	NVL5101	NVL10000	NVL20000
Capacity	510 g	1100 g	2100 g	5100 g	10000 g	20000 g
Readability	0.1 g	0.1 g	0.1 g	0.5 g	1 g	1 g
Repeatability	0.1 g	0.1 g	0.1 g	0.5 g	1 g	1 g
Linearity	0.2 g	0.2 g	0.2 g	1 g	2 g	2 g
Span Calibration Mass	300 g	500 g	1 kg	3 kg	5 kg	10 kg
Linearity Calibration Mass	300 g, 500 g	500 g, 1000 g	1 kg, 2 kg	3 kg, 5 kg	5 kg, 10 kg	10 kg, 20 kg
Application Modes	Weighing, Percent Weighing, Parts Counting, Check Weighing, Display Hold, Accumulate/Totalize					
Weighing Units	Gram, Kilogram, Pound, Ounce (decimal or fractional), Pound:Ounce (decimal or fractional), Ounce Troy, Grain, Newton, Carat, Pennyweight, Hong Kong Tael, Taiwan Tael, Singapore Tael, Tical, Tola					
Battery Power	4 C (LR14) batteries (not included) or Internal rechargeable lead acid battery (optional), 6V1.2AH					
Pan Size (W x D)	194 x 203 mm					
Scale Dimensions (W x D x H)	204 x 282 x 74 mm					
Shipping Dimensions (W x D x H)	390 x 325 x 170 mm					
Net Weight ²	1.5 kg					
Shipping Weight ²	2.3 kg					
Operating Temperature Range	10°C to 40°C					

Note 1:

/2 = LED display

Note 2: /1 and /3 models add 0.5kg

Navigator™ Portable Balances

Standard Models – Navigator

Model ¹	NV212	NV511	NV1101	NV2101	NV4101	NV5101	NV311M	NV3100M	
Capacity	210 g	510 g	1100 g	2100 g	4100 g	5100 g	310 g	3100 g	
Readability	0.01 g	0.1 g	0.1 g	0.1 g	0.2 g	0.5 g	0.1 g	1 g	
Verification Interval ^e	N/A	N/A	N/A	N/A	N/A	N/A	0.1 g	1 g	
Repeatability	0.01 g	0.1 g	0.1 g	0.1 g	0.2 g	0.5 g	0.1 g	1 g	
Linearity	0.02 g	0.2 g	0.2 g	0.2 g	0.4 g	1 g	0.1 g	1 g	
Span Calibration Mass	200 g	300 g	500 g	1 kg	2 kg	3 kg	200 g	2 kg	
Linearity Calibration Mass	100 g, 200 g	300 g, 500 g	500 g, 1000 g	1 kg, 2 kg	2 kg, 4 kg	3 kg, 5 kg	200 g, 300 g	2 kg, 3 kg	
Application Modes	Weighing, Percent Weighing, Parts Counting, Check Weighing, Display Hold, Accumulate/Totalize								
Weighing Units	Gram, Kilogram, Pound, Ounce (decimal or fractional), Pound:Ounce (decimal or fractional), Ounce Troy, Grain, Newton, Carat, Pennyweight, Hong Kong Tael, Taiwan Tael, Singapore Tael, Tical, Tola						Gram	Gram, Kilogram	
Battery Power	4 AA (LR6) batteries (not supplied)								
Pan Size (W x D)	Ø120 mm	190 x 138 mm					Ø120 mm	190 mm x 138 mm	
Scale Dimensions (W x D x H)	204 x 212 x 58 mm								
Shipping Dimensions (W x D x H)	305 x 255 x 134 mm								
Net Weight	0.9 kg								
Shipping Weight	1.4 kg								

Other Standard Features and Equipment

Integral security bracket, stability indicator, software overload/underload indicators, low battery indicator, auto shut-off, AC adapter, user selectable backlight settings, user selectable printing options, user selectable communications settings.

Accessories	OHAUS Number
Battery Rechargeable Kit, Navigator XT.....	83032106
RS232 Interface Kit, Navigator Series.....	83032107
USB Interface Kit, Navigator Series.....	83032108
Ethernet Interface Kit, Navigator Series.....	83032109
In Use Cover, Navigator.....	83032223
In Use Cover, Navigator XL.....	83032222
In-Use Cover, Navigator XT.....	83032221
Carrying Case, Navigator.....	83032226
Carrying Case, Navigator XL.....	83032225
Carrying Case, Navigator XT.....	83032224

Compliance

- Electromagnetic Compatibility: C-Tick, CE Class B, FCC Class B, ICES-003 Class B
- Safety (AC adaptors only): C-Tick, CCC, CE, cCSAus, KTL, PSE, TUV-GS
 - Compliant to Directive 2002/96/EC on waste electrical and electronic equipment (WEEE)
 - Compliant to Directive 2002/95/EC on the restriction of the use of certain hazardous substances in electrical and electronic equipment (RoHS)
- Quality: OHAUS quality management system registered to ISO 9001:2008

www.ohaus.com

* ISO 9001:2008
Registered Quality Management System

© Copyright Ohaus Corporation



X-ON Electronics

Largest Supplier of Electrical and Electronic Components

Click to view similar products for [Ohaus](#) manufacturer:

Other Similar products are found below :

[DISCRETE I/O KIT](#) [D22M300BXZ-M](#) [83032109](#) [SD200L](#) [83032108](#) [30037449](#) [11117004](#) [87000009](#) [NVT6201](#) [NVT6400M](#) [CR2200](#)
[CR221](#) [CR621](#) [CX2200](#) [SD SD75L](#) [30037447](#) [83032107](#) [CX221](#) [CX621](#) [NV1201](#) [30037448](#) [NVT12000](#) [CR5200](#) [NVT6200](#)