

AVR-USB-162 development board

Users Manual

April 2008

Copyright(c) 2008, OLIMEX Ltd, All rights reserved

INTRODUCTION:

AT90USB162 is the easiest way to add USB functionality to your next device, Atmel provide free open source HID (mouse, keyboard) and CDC (USB-to-RS232) code and on top of this AT90USB162 cost is same as ATmega16, so what you are waiting for? AVR-USB-162 board provide the basic circuit necessary to work with AT90USB162 - USB connector and circuit, external power supply if your circuit require more power than 100mA which usually USB port provide, button, status LED, reset button. All AT90USB162 come from Atmel pre-programmed with bootloader which allow code to be programmed inside the chip without any external programmer, just download the FLIP software from Atmel web site and load your HEX code inside AT90USB162. To enter the bootloader mode you should press and hold BUT button, then press and release RST button. If you prefer to use ICSP programmer note that only AVR-ISP-MK2 is supporting AT90USB162 as there are pretty new devices, probably AVR Dude will add support later, but for the moment you can't use AVR-PG1 or AVR-PG2 for ICSP programming, another bad news is that AT90USB162 supports only debug Wire not JTAG so to debug it you should have the expensive AT-JTAGICE-MK2.

BOARD FEATURES:

- CPU: AT90USB162 microcontroller
- ICSP 5x2 pin connector for in-circuit programming
- Debug Wire could be performed by 3 wires connected to ICSP
- USB connector
- BUT - user button
- RST - reset button
- User LED
- takes power from USB no need for external adapter
- external power supply and voltage regulator if USB can't provide enough power
- 8Mhz crystal oscillator
- extension pin headers for all uC pin
- four mounting holes 3.3 mm (0.13")
- Prototype area: grid - 100 mils, VCC and GND bus
- PCB: FR-4, 1.5 mm (0,062"), solder mask, silkscreen component print
- Dimensions: 100x80 mm (3.9x3.15")

ELECTROSTATIC WARNING:

The AVR-USB-162 board is shipped in protective anti-static packaging. The board must not be subject to high electrostatic potentials. General practice for working with static sensitive devices should be applied when working with this board.

BOARD USE REQUIREMENTS:

- Cables:** 1.8 meter USB A-B cable to connect to USB host.
- Hardware:** AVR-ISP500, AVR-ISP500-TINY or AVR-ISP500-ISO, AVR-DRAGON, ATICEJTAG MK2 or other compatible tools.
- Software:** WINAVR GNU C compiler and AVR-STUDIO.

BOARD LAYOUT:

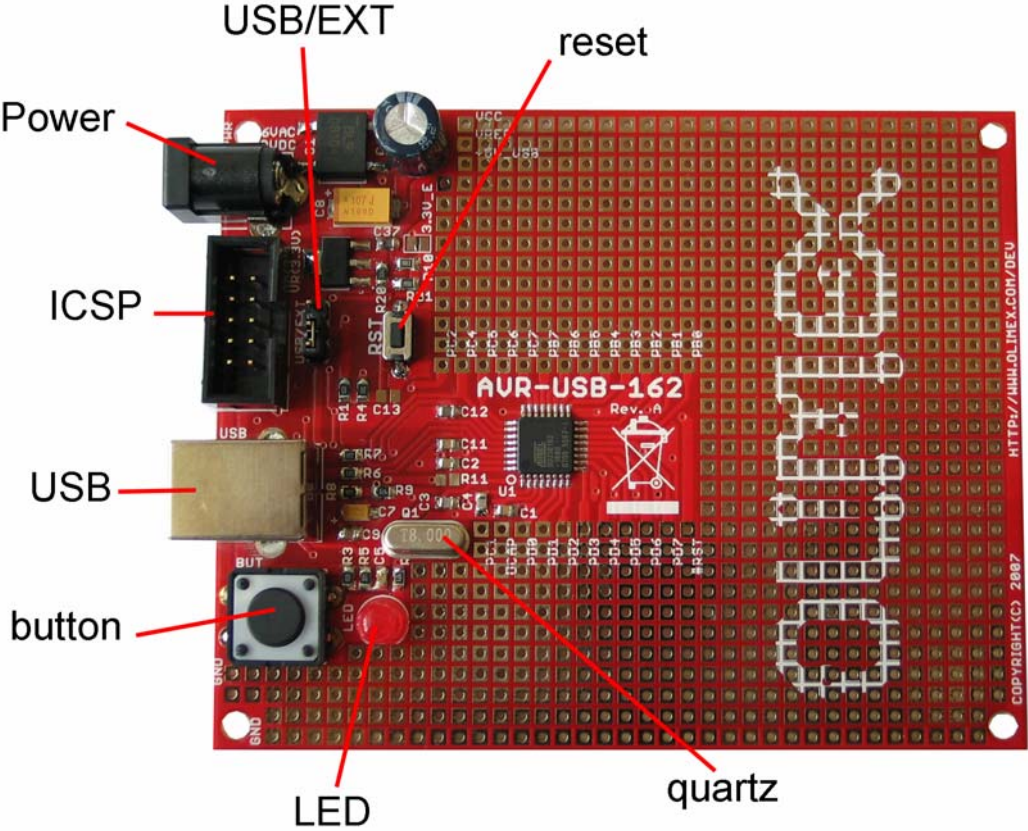

SCHEMATIC:

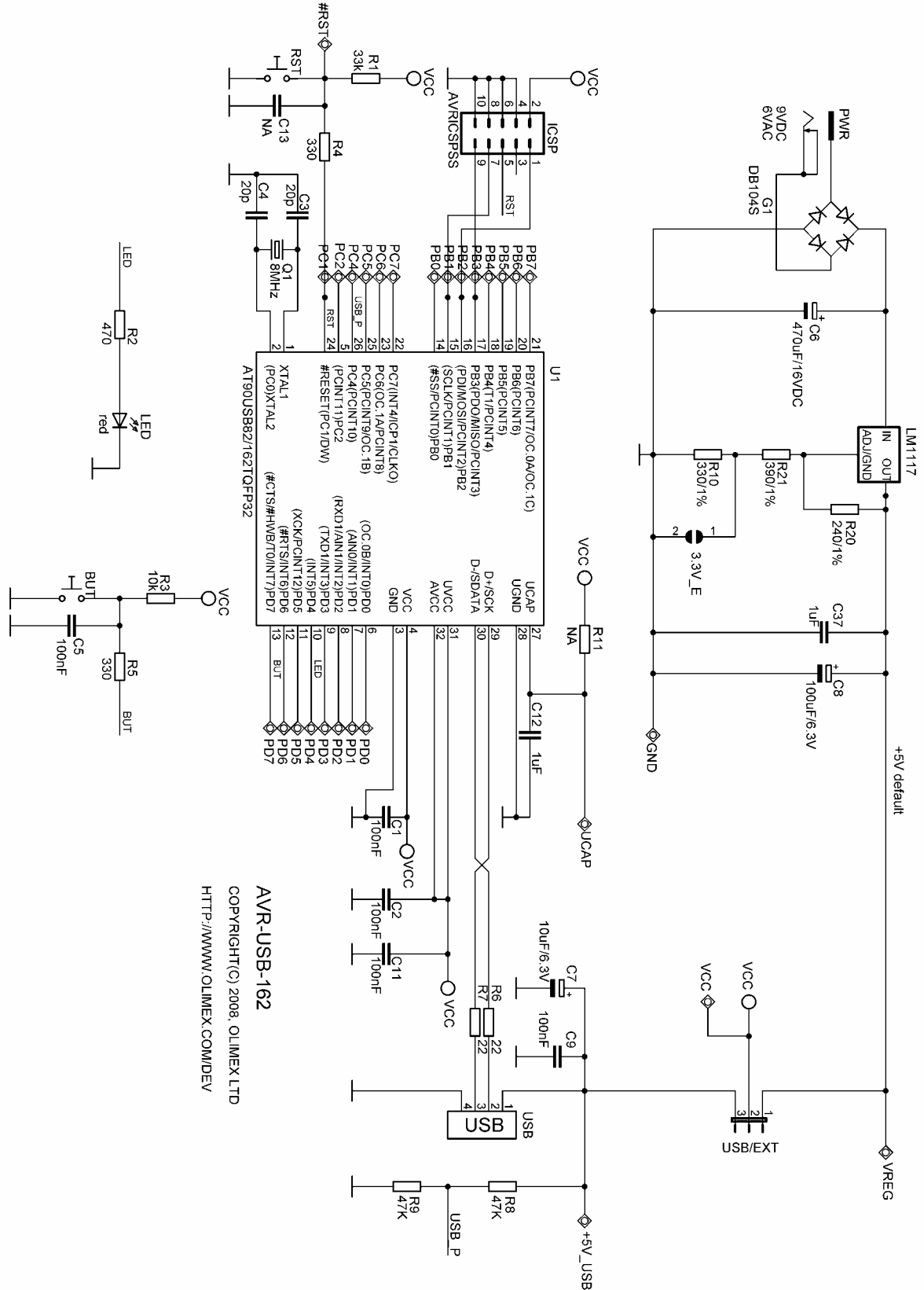

AVR-USB-162
 COPYRIGHT(C) 2008, OLIMEX LTD
 HTTP://WWW.OLIMEX.COM/DEV

PROCESSOR FEATURES:

AVR-USB-162 board use Atmel 8-bit AVR CPU **AT90USB162** with these features:

- CPU clock up to 16Mhz
- FLASH 16KB
- 512-byte SRAM
- 512-byte EEPROM
- WDT
- Timers x2
- SPI x1
- USART x1
- USB x1
- GPIO 22 Programmable I/O Lines (multiplexed with peripherals)
- operating voltage 2.7-5.5V
- temperature -40C +85C

AT90USB162 Block Diagram

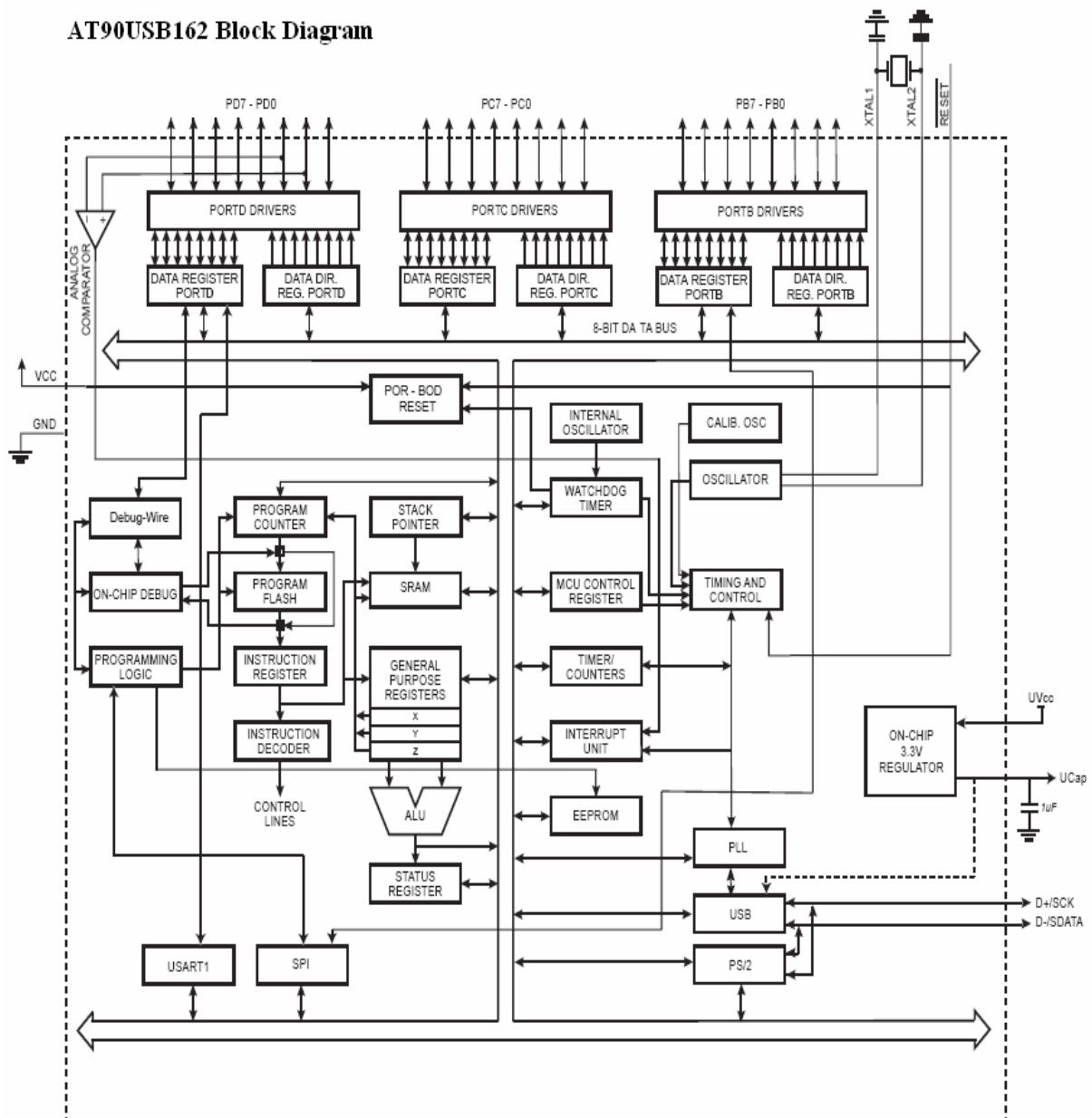

MEMORY MAP:

Figure 5-1. Program Memory Map

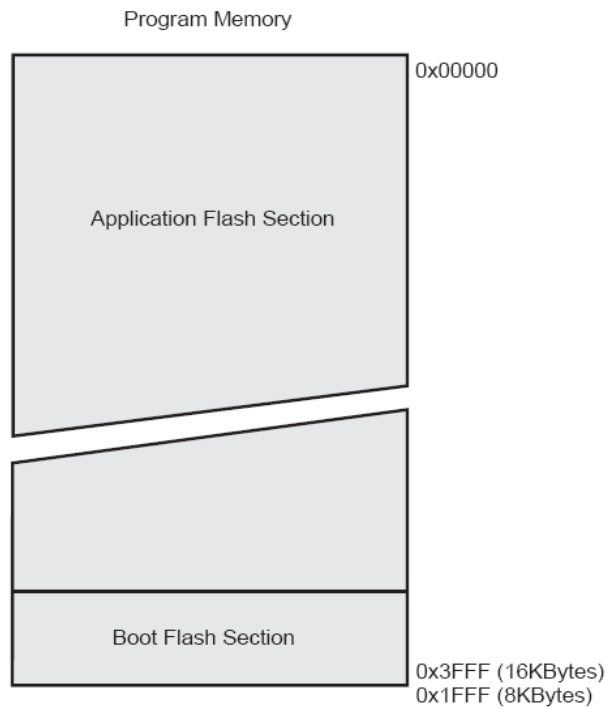

Data Memory Map

Data Memory

32 Registers	\$0000 - \$001F
64 I/O Registers	\$0020 - \$005F
160 Ext I/O Reg.	\$0060 - \$00FF
	\$0100
Internal S RAM (512 x 8)	
	\$2FF

POWER SUPPLY CIRCUIT:

AVR-USB-162 can take power from two sources:

- USB connector where 5V power supply is applied by USB host
- Power Input (PWR) where 9VDC or 6VAC may be applied

The board power consumption is: about 10÷15 mA with all peripherals and MCU running at full speed, there are 5 different power saving(sleep) modes which may put **AT90USB162** in power down mode and in these modes the consumption of the MCU is only few micro amperes.

RESET CIRCUIT:

AVR-USB-162 reset circuit is made-up with RC group R1 - 33K and C13 - 100nF (NA).

External reset can be generated by PC1 prototype pin. Manual reset is possible by the RESET button.

CLOCK CIRCUIT:

Quartz crystal 8Mhz is connected to **AT90USB162**. Internal USB PLL circuit can multiply this frequency up to 48MHz.

EXTERNAL CONNECTOR DESCRIPTION:

Like it's shown at the figure below, every one of all 22 GPIO Programmable I/O Lines is led to prototype area.

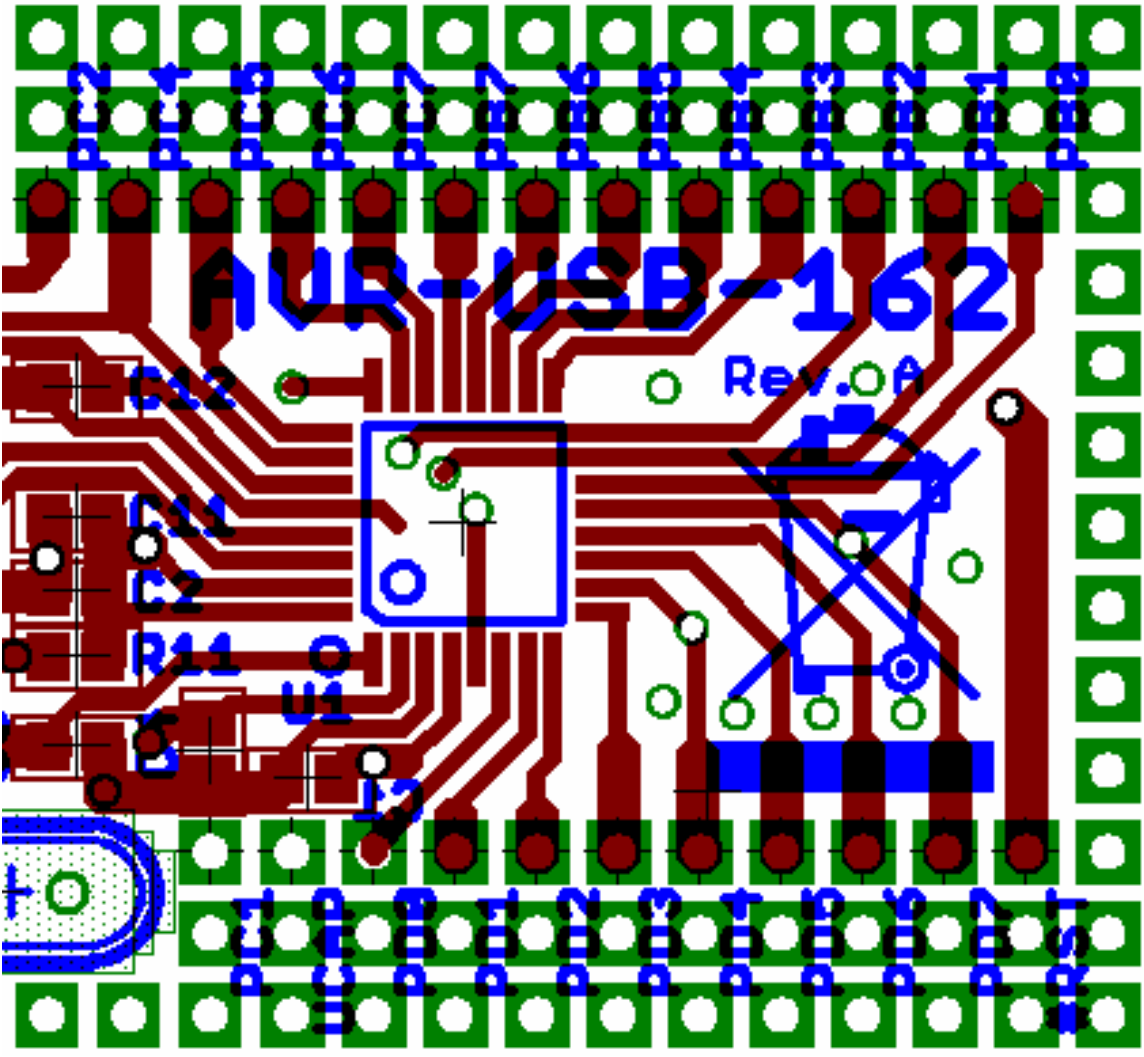

JUMPER DESCRIPTION:

USB/EXT Select **AVR-USB-162** power source.
Default state closed (shorted)

- USB - **AVR-USB-162** is supplied by USB host
- EXT - **AVR-USB-162** is supplied by external source connected to Power Input (PWR)

USB/EXT



INPUT/OUTPUT:

User button with name **BUT** – connected to **AT90USB162** pin.13 (PD7).

User LED is connected to **AT90USB162** pin.10 PD4. It is possible to use PD4 port for other purpose, because it is lead to prototype area;

CONNECTOR DESCRIPTION:

ICSP:

AT90USB162 is programmed via this standard connector and one of these programmers **AVR-ISP500**, **AVR-ISP500-TINY**, **AVR-ISP500-ISO** or other compatible tools.

USB:

Pin #	Signal Name
1	+5V_USB
2	D-
3	D+
4	GND

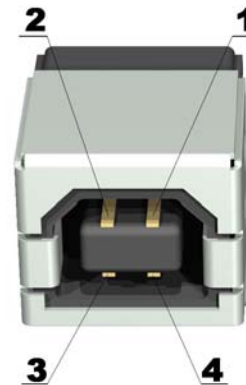

PWR:

Pin #	Signal Name
1	Power Input
2	GND

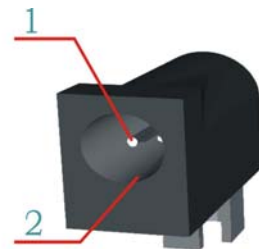

ORDER CODE:

AVR-USB-162 - assembled and tested (no kit, no soldering required)

How to order?

You can order to us directly or by any of our distributors.

Check our web www.olimex.com/dev for more info.



All boards produced by Olimex are ROHS compliant

Revision history:

Create April 2008

Disclaimer:

© 2008 Olimex Ltd. All rights reserved. Olimex®, logo and combinations thereof, are registered trademarks of Olimex Ltd. Other terms and product names may be trademarks of others.

The information in this document is provided in connection with Olimex products. No license, express or implied or otherwise, to any intellectual property right is granted by this document or in connection with the sale of Olimex products.

Neither the whole nor any part of the information contained in or the product described in this document may be adapted or reproduced in any material from except with the prior written permission of the copyright holder.

The product described in this document is subject to continuous development and improvements. All particulars of the product and its use contained in this document are given by OLIMEX in good faith. However all warranties implied or expressed including but not limited to implied warranties of merchantability or fitness for purpose are excluded.

This document is intended only to assist the reader in the use of the product. OLIMEX Ltd. shall not be liable for any loss or damage arising from the use of any information in this document or any error or omission in such information or any incorrect use of the product.

X-ON Electronics

Largest Supplier of Electrical and Electronic Components

Click to view similar products for [Development Boards & Kits - AVR category](#):

Click to view products by [Olimex manufacturer](#):

Other Similar products are found below :

[3264](#) [ATAVRPARROT](#) [ATSAMR21B18MZ210PAT](#) [CS-EASE-03](#) [EV35F40A](#) [A100053](#) [1222](#) [MIKROE-2474](#) [1260](#) [KIT0018](#) [1405](#) [DEV-10914](#) [1500](#) [1639](#) [1657](#) [174](#) [193](#) [2000](#) [2010](#) [3208](#) [ATRCB256RFR2](#) [ATXMEGAA1U-XPRO](#) [2085](#) [ATSTK600-SC48](#) [2290](#) [2488](#) [DEV-11520](#) [2590](#) [296](#) [3000](#) [ATAVRBLE-IOT](#) [ATTINY416-XNANO](#) [DFR0010](#) [DFR0100](#) [DFR0164](#) [DFR0191](#) [DFR0221](#) [DFR0222](#) [DFR0225](#) [DFR0233](#) [DFR0282](#) [DFR0327](#) [DRI0027](#) [KIT0111](#) [K030007](#) [DFR0351](#) [DEV-13614](#) [KIT-14265](#) [3379](#) [DFR0216](#)