

STM32-H405 development board USER'S MANUAL

Revision B, April 2016
Designed by OLIMEX Ltd, 2015



All boards produced by Olimex LTD are ROHS compliant

DISCLAIMER

© 2016 Olimex Ltd. Olimex®, logo and combinations thereof, are registered trademarks of Olimex Ltd. Other product names may be trademarks of others and the rights belong to their respective owners.

The information in this document is provided in connection with Olimex products. No license, express or implied or otherwise, to any intellectual property right is granted by this document or in connection with the sale of Olimex products.

The hardware design of STM32-H405 development board is considered propriety. The board's schematics are available in pdf format. The original schematic and design files are not available to the public.

The part of the software written by Olimex is released under GPL. However, note that the examples that we distribute are based on the libraries and projects released by IAR Systems. Make sure that you are acquainted with the license agreement of IAR Embedded Workbench before using, publishing, or distributing any code based on the software released by Olimex.

It is possible that the pictures in this manual differ from the actual appearance of the latest revision of the board.

The product described in this document is subject to continuous development and improvements. All particulars of the product and its use contained in this document are given by OLIMEX in good faith. However all warranties implied or expressed including but not limited to implied warranties of merchantability or fitness for purpose are excluded. This document is intended only to assist the reader in the use of the product. OLIMEX Ltd. shall not be liable for any loss or damage arising from the use of any information in this document or any error or omission in such information or any incorrect use of the product.

This evaluation board/kit is intended for use for engineering development, demonstration, or evaluation purposes only and is not considered by OLIMEX to be a finished end-product fit for general consumer use. Persons handling the product must have electronics training and observe good engineering practice standards. As such, the goods being provided are not intended to be complete in terms of required design-, marketing-, and/or manufacturing-related protective considerations, including product safety and environmental measures typically found in end products that incorporate such semiconductor components or circuit boards.

Olimex currently deals with a variety of customers for products, and therefore our arrangement with the user is not exclusive. Olimex assumes no liability for applications assistance, customer product design, software performance, or infringement of patents or services described herein.

THERE IS NO WARRANTY FOR THE DESIGN MATERIALS AND THE COMPONENTS USED TO CREATE STM32-H405. THEY ARE CONSIDERED SUITABLE ONLY FOR STM32-H405.

Table of Contents

DISCLAIMER.....	2
CHAPTER 1 OVERVIEW.....	5
1. Introduction to the chapter.....	5
1.1 Features.....	5
1.2 Target market and purpose of the board.....	6
1.3 Similar boards.....	6
1.4 Document Organization.....	6
CHAPTER 2: BOARD DESCRIPTION.....	7
2.1 Layout (top view).....	7
2.2 Layout (bottom view).....	8
2.3 EXT pinout (bottom view).....	9
CHAPTER 3 SETTING UP THE STM32-H405 BOARD.....	10
3. Introduction to the chapter.....	10
3.1 Electrostatic warning.....	10
3.2 Requirements.....	10
3.2.1 Hardware requirements:.....	10
3.2.2 Software requirements:.....	11
3.3 Powering the board.....	12
3.4 Programming the board.....	12
3.4.1 Using JTAG debugger.....	12
3.4.2 Using USB cable.....	12
3.5 Prebuilt software.....	13
CHAPTER 4 THE STM32F405 MICROCONTROLLER.....	14
4. Introduction to the chapter.....	14
4.1 The STM32F405RG features.....	14
CHAPTER 5 CONTROL CIRCUITRY AND HARDWARE MODULES.....	16
5. Introduction to the chapter.....	16
5.1 Reset.....	16
5.2 Clocks.....	16
5.3 Power supply circuit.....	16
CHAPTER 6 CONNECTORS AND PINOUT.....	17
6. Introduction to the chapter.....	17
6.1 USB connector.....	17
6.2 JTAG/SWD debug connector.....	18
6.3 EXT connectors.....	19
6.3.1 EXT1 header.....	19
6.3.2 EXT2 header.....	20
6.4 Jumper description.....	20
6.4.1 BOOT memory select jumpers.....	20

6.4.2 R-T jumper.....	21
6.4.3 VBAT signal and jumper.....	21
6.4.4 LED E.....	21
6.4.5 USBP E.....	21
6.5 Additional hardware components.....	22
CHAPTER 7 BLOCK DIAGRAM AND MEMORY.....	23
7. Introduction to the chapter.....	23
7.1 Processor family block diagram.....	23
7.2 Physical memory map.....	24
CHAPTER 8 SCHEMATICS.....	25
8. Introduction to the chapter.....	25
8.1 Eagle schematic.....	25
8.2 Physical dimensions.....	27
CHAPTER 9 REVISION HISTORY AND SUPPORT.....	28
9. Introduction to the chapter.....	28
9.1 Document revision.....	28
9.2 Board revision.....	28
9.3 Useful web links and purchase codes.....	29
9.4 Product support.....	30

CHAPTER 1 OVERVIEW

1. Introduction to the chapter

Thank you for choosing this general-purpose development board designed and assembled by Olimex! This document provides a user's guide for the Olimex STM32-H405 board. As an overview, this chapter gives the scope of this document and lists the board's features. A comparison between boards similar to STM32-H405 is presented. The document's organization is then detailed.

The STM32-H405 development board enables code development of applications running on the microcontroller STM32F405RG, manufactured by STMicroelectronics.

STM32-H405 board is an entry level development board for the new ARM Cortex M4 family of devices produced by STMicroelectronics Inc. With STM32-H405 you can explore the features of STM32 family on budget, the board has everything necessary to build simple applications: USB port where power is taken and power supply circuit, reset and oscillator circuits, JTAG port for programming and debugging, programmable LED and programmable button.

Although a very simple board, it is sufficient enough for building USB applications like PC mouse, USB mass storage device, USB audio class device, USB to virtual RS232 port. There are plenty of GPIOs on the extension headers which can be used to connect your additional circuits.

1.1 Features

The board has the following list of features:

- MCU: STM32F405RG ARM Cortex M4 in LQFP64 package that operates up to 168 Mhz; with 1024KB flash memory; (192+4)kB SRAM; 2×USB; 2×CAN; 2 x I2C; 3×12-bit ADC×16 channels; 2×12-bit DAC; 2×UART; 3×SPI; 17 timers; with up to 51 GPIOs
- Standard JTAG connector with ARM 2×10 pin layout for programming/debugging with ARM-JTAG
- USB type B connector
- User button
- RESET button
- User LED
- Power supply LED
- On-board voltage regulator 3.3V with up to 800mA current
- Single power supply: takes power from USB port or extension connector pin
- 8 Mhz crystal oscillator
- 32768 Hz crystal and RTC backup battery connector
- Extension headers with 0.1" step for all uC ports
- PCB: FR-4, 1.5 mm (0,062")
- Dimensions: (61×34)mm ~ (2.4×1.3)"
- Distance between the ext connectors: 25.4mm ~ 1"

1.2 Target market and purpose of the board

STM32-H405 is a development board featuring a ARM Cortex-M4 microcontroller. The board can be powered by a number of different sources. It can be programmed with a debugger via JTAG or SWD, or alternatively with a cable via USB. The board has a lot of GPIO pins exposed.

The board is suitable for numerous tasks and situations. The power of ARM and the creativity of OLIMEX come at the best price and the well-known quality.

Every ARM enthusiast would see STM32-H405 as an interesting bargain and quite capable board for its low price.

1.3 Similar boards

The STM32H405RG microcontroller is also present in two other Olimex-made boards – STM32-P405 and STM32-405STK. Both boards have more built-in peripherals compared to STM32-H405.

STM32-P405 has MMC card interface with connector, UEXT connector, CAN interface with connector, UART interface with DE-9 connector, built-in power barrel jack, and a small prototype area.

STM32-405STK has micro SD card interface with connector, mini USB, 84x48 BW display, microphone input with connector; headphone output with connector, UEXT connector. The board can be powered by a 1.5V AA battery – there is a battery holder provided.

Another board, quite similar to STM32-H405, is STM32-H103; the board designs are almost identical – the main difference is that STM32-H103 uses STM32F103RB.

If you are looking for a board with similar processor and Ethernet functionality take a look at STM32-E407 board. It uses STM32H407ZG.

1.4 Document Organization

Each section in this document covers a separate topic, organized as follows:

- Chapter 1 is an overview of the board usage and features
- Chapter 2 contains the board's layout
- Chapter 3 provides a guide for quickly setting up the board
- Chapter 4 describes the component that is the heart of the board: the STM32F405 microcontroller
- Chapter 5 is an explanation of the control circuitry associated with the microcontroller to reset. Also shows the clocks on the board
- Chapter 6 covers the connector pinout, peripherals and jumper description
- Chapter 7 shows the block diagram and the memory map
- Chapter 8 provides the schematics
- Chapter 9 contains the revision history, useful links and support information

CHAPTER 2: BOARD DESCRIPTION

In this chapter you will get acquainted with the main parts of the board. Note the names used on the board differ from the names used to describe them. For the actual names check the STM32-H405 board itself.

2.1 Layout (top view)

The picture below shows the top side of the board and highlights the most important parts.

Notice that all on-board jumpers are SMD type – in order to change the position of the jumpers you would either need to cut between the pads of the jumper or solder the pads together.

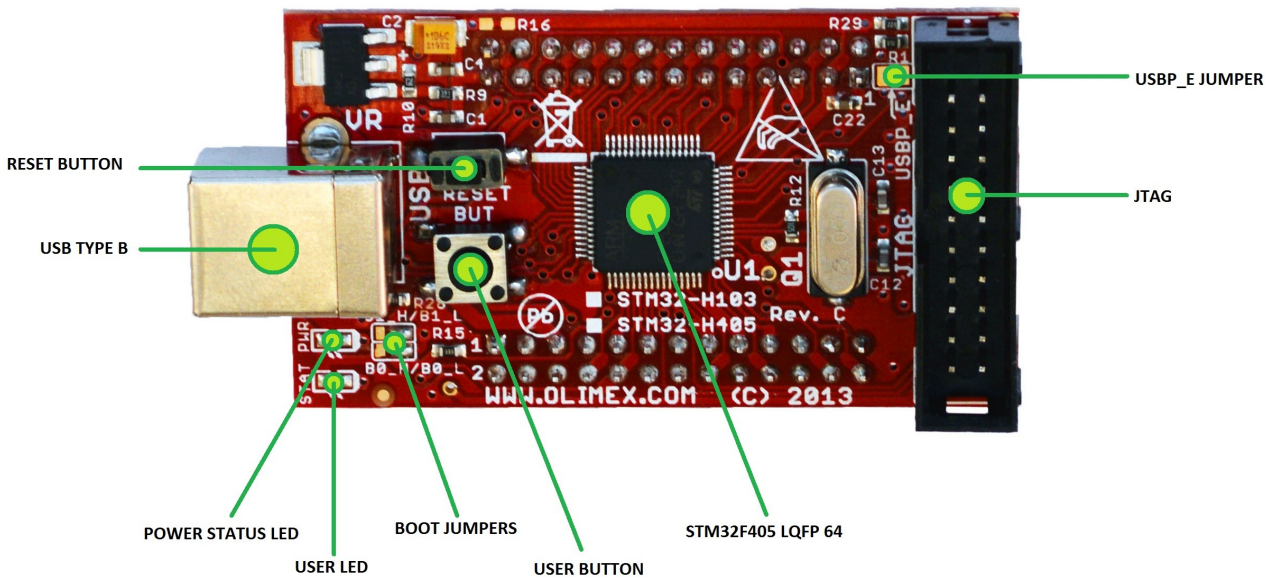

2.2 Layout (bottom view)

The two most important parts at the bottom of the board are the two 26-pin headers EXT1 and EXT2. They allow easier access to some of the pins of the microcontroller. Refer to the pinout on the next page for more detailed information on the signals available on EXT1 and EXT2.

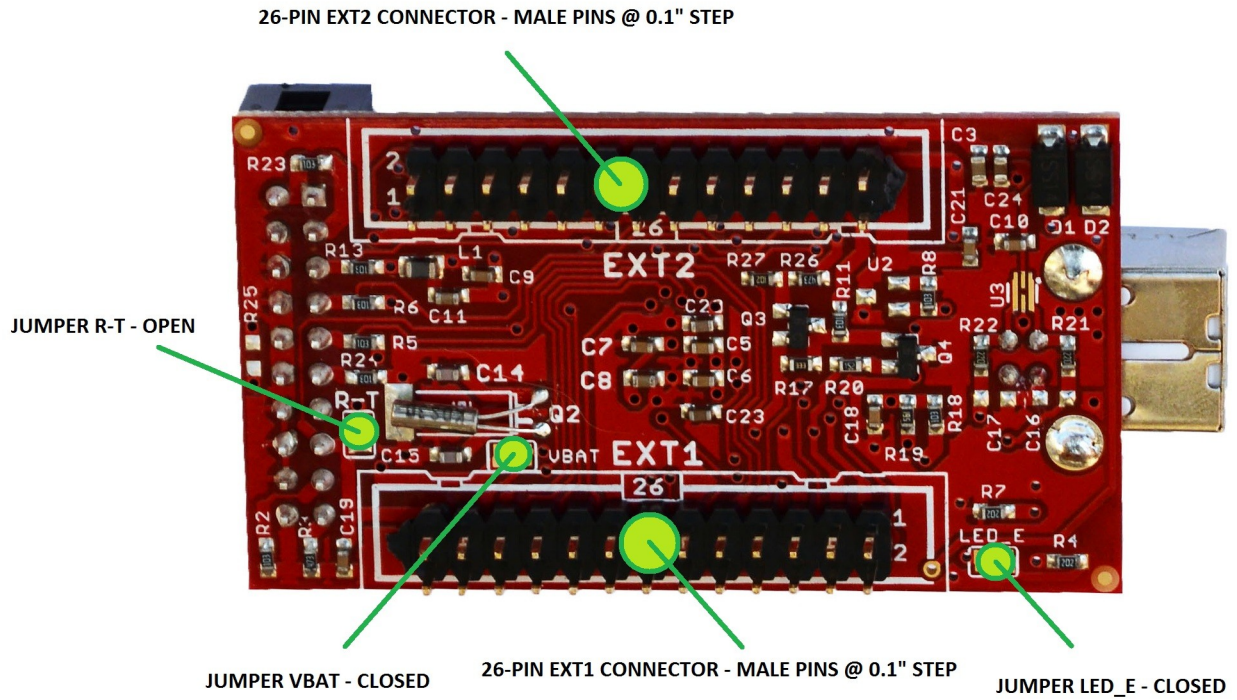

2.3 EXT pinout (bottom view)

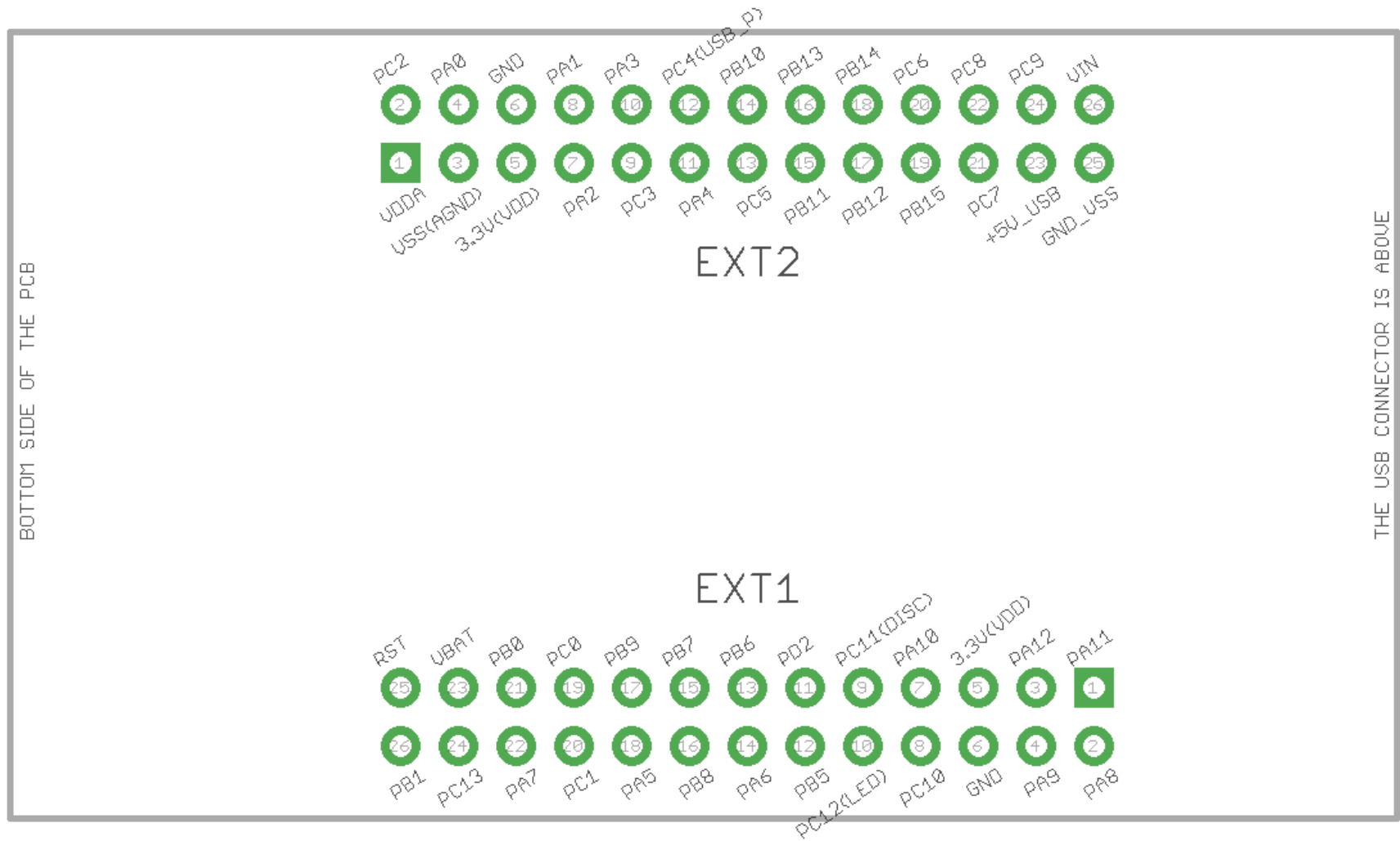

CHAPTER 3 SETTING UP THE STM32-H405 BOARD

3. Introduction to the chapter

This section helps you set up the STM32-H405 development board for the first time. Please consider first the electrostatic warning to avoid damaging the board, then discover the hardware and software required to operate the board.

The procedure to power up the board is given, and a description of the default board behavior is detailed.

3.1 Electrostatic warning

STM32-H405 is shipped in a protective anti-static package. The board must not be exposed to high electrostatic potentials. A grounding strap or similar protective device should be worn when handling the board to avoid electrostatic discharge.

3.2 Requirements

In order to set up the STM32-H405 optimally you would need a hardware debugger tool and compatible software tools. More detailed information may be found in the sub-chapters below:

3.2.1 Hardware requirements:

- Standard ARM JTAG/SWD debugger/programmer – it can power the board and gives you the ability to program/debug the board – to select the correct tool make sure that it is compatible with the software tools which you are going to use during development. Also makes sure that the tool is compatible with the STM32F405 processor.

IMPORTANT: The board can be programmed using only a USB cable. However, it is a slow process – this way of programming is not suitable for evaluation, research and development. Using the USB DFU bootloader might be good idea only if you need to program the board once or twice.

Additional components can be acquired in order to increase the functionality of the board:

- USB cable with type A and type B connectors – in case you want to power the board from the USB port of your personal computer or, alternatively, if you want need to utilize the board's USB interface
- Jumper wires – allow solderless access to the exposed pins; if you want to directly connect to the extension headers use wires with a female connectors.

Some of the suggested items can be purchased by Olimex, for instance:

ARM-USB-TINY-H – high-speed OpenOCD ARM JTAG debugger

ARM-USB-OCD-H – high-speed OpenOCD ARM JTAG debugger with buffer protection

ARM-JTAG-COOCOX – high-speed CooCox IDE JTAG/SWD debugger

USB-A-B-CABLE – cable with USB type A and USB type B connectors at each end

JW-200x10-FM – ten jumper wires with female-male connectors

3.2.2 Software requirements:

In order to change the code on the board you would need an ARM C compiler and debugger software, the possible software options are:

- free open-source software: OpenOCD (all Olimex OpenOCD JTAG debuggers are supported in OpenOCD)
- free software: CooCox IDE (all Olimex JTAGs are supported in CooCox)
- commercial software: EW-ARM from IAR Systems AB; CrossWorks from Rowley (all Olimex OpenOCD JTAG debuggers are supported in IAR and Rowley Crossworks; note that our debugging tools doesn't work in Keil MDK-ARM).

Comparison table						
	Is it free or commercial	Initial struggle and set-up time	STM32-H405 example provided by Olimex	Is it open-source	Does it work with Olimex OpenOCD debuggers	Quality of customer support
OpenOCD	Free	Highest	No	Yes	Yes	Bad
CooCox IDE	Free	High	No	No	Yes	Mediocre
Rowley Crossworks for ARM	Commercial (free time-limited evaluation version)	Low	No	No	Yes	Good
Keil MDK-ARM	Commercial (free size-limited evaluation version)	Low	No	No	No	Good
IAR EW for ARM	Commercial (free size-limited version and free time-limited evaluation version)	Low	Yes	No	Yes	Good

It is a good idea to study the example that is provided by Olimex for your board. If you are not willing to purchase the software just use the evaluation version initially.

Specifically, for STM32-H405 Olimex provides only IAR EW for ARM example. It is a good idea to download the latest time-limited evaluation version.

3.3 Powering the board

The board can be powered in one of the following ways:

- 1) Using the JTAG or SWD debugger – the board gets powered via the 20-pin 0.1” step JTAG connector; note that some tool might hold the board in RESET state – make sure to release the microcontroller from RESET to be able to see the execution of your code
- 2) Using USB cable – the board gets powered via the USB connector; the power is provided, typically, by your computer's USB port
- 3) Using external power supply – in this case, the board gets powered via the EXT2 header – provide +5V DC to pin #26 of this header; then connect the power supply's GND to pin #25 of EXT2.

3.4 Programming the board

The programming of the board is also fairly straight forward (unlike the software development for the board):

3.4.1 Using JTAG debugger

This is the recommended method of changing the software of the board. This is fairly simple from hardware point of view – just plug the male 20-pin JTAG connector of your hardware tool to the 20-pin female JTAG connector of STM32-H405.

Refer to the documentation of your debugger and also to the documentation of the software of choice on instructions how to set the environment.

3.4.2 Using USB cable

The board can be programmed without a debugger tool. In this case you only need a personal computer that is able to run Windows software and an USB cable.

STM32-H405 has a built-in USB DFU bootloader that allows such programming.

Programming STM32-H405 via the bootloader is a slow process that requires the re-configuration of SMD jumper. It is not recommend for initial evaluation, research and development (use any ARM JTAG debugger instead). Using the bootloader might be good idea only if you need to program the board once or twice.

How to do it:

1. Change the position of one of the boot SMD jumpers – B0_H/B0_L (the bottom one). By default it is set to position B0_L – you need to change it to B0_H. This requires soldering.
2. After the adjustment is done you can connect to the DfuSe software released by STM. It available for download from STM's official web-site. Search for “STSW-STM32080”.
3. Install the software and run it.

4. Connect the board via the USB cable to the personal computer.
5. The board should now be recognized in the software. The bootloader application provided by STM32 is a bit strange. It works only with dfu files. To upload other binary files (hex, bin, s19) you would need to use additional converter tool (“DFU File Manager”; it converts hex, bin, s19 to dfu and vice versa). I highly recommend you to read carefully the document about the usage of the Dfuse called “Getting started with DfuSe USB device firmware upgrade”. Search for “UM0412”.
6. Note that once you've uploaded the software you would need to change the jumpers back to the original position – else the bootloader would start every time and the user program (typically stored in the flash memory) would not execute.

3.5 Prebuilt software

Upon powering the board the STAT and PWR LEDs should turn on.

The board comes with the software which was downloaded and used during the testing of the board. This software and its source code could not serve any purpose to the customer, who purchased the board, since it requires additional custom hardware. That is why there is a meaningful example available for download at the web-page of the board. Please download and extract the following archive which contains the recommended initial demo:

https://www.olimex.com/Products/ARM/ST/STM32-H405/resources/STM32-H405_examples.zip

Note that the demo can be opened and compiled out-of-the-box ONLY with IAR Embedded Workbench for ARM. You can get a free code-size or time-limited evaluation version of IAR EW for ARM from their official web-site (requires registration).

Refer to the “ReadMe.txt” file inside the archive for more information.

CHAPTER 4 THE STM32F405 MICROCONTROLLER

4. Introduction to the chapter

Some of the details about the main processor in the design of STM32-H405 (STM32F405RG) are mentioned in this chapter. The information is a modified version of the datasheet provided by its manufacturers from ST.

It is highly recommended to refer to the original datasheet which might be downloaded from the ST's official web-side.

4.1 The STM32F405RG features

STM32-H405 board uses STM32F405RG microcontroller designed and manufactured by STMicroelectronics. It has the following features that distinguish it from the rest of the family:

- Core: ARM 32-bit Cortex™-M4 CPU with FPU, Adaptive real-time accelerator (ART Accelerator™) allowing 0-wait state execution from Flash memory, frequency up to 168 MHz, memory protection unit, 210 DMIPS/1.25 DMIPS/MHz (Dhrystone 2.1), and DSP instructions
- Memories
 - 1 Mbyte of Flash memory
 - 192+4 Kbytes of SRAM including 64-Kbyte of CCM (core coupled memory) data RAM
 - Flexible static memory controller supporting Compact Flash, SRAM, PSRAM, NOR and NAND memories
- LCD parallel interface, 8080/6800 modes
- Clock, reset and supply management
 - 1.8 V to 3.6 V application supply and I/Os
 - POR, PDR, PVD and BOR
 - 4-to-26 MHz crystal oscillator
 - Internal 16 MHz factory-trimmed RC (1% accuracy)
 - 32 kHz oscillator for RTC with calibration
 - Internal 32 kHz RC with calibration
 - Sleep, Stop and Standby modes
 - VBAT supply for RTC, 20×32 bit backup registers + optional 4 KB backup SRAM
- 3×12-bit, 2.4 MSPS A/D converters: 24 channels and 7.2 MSPS in triple interleaved mode
- 2×12-bit D/A converters
- General-purpose DMA: 16-stream DMA controller with FIFOs and burst support
- Up to 17 timers: up to twelve 16-bit and two 32-bit timers up to 168 MHz, each with up to 4 IC/OC/PWM or pulse counter and quadrature (incremental) encoder input
- Debug mode
 - Serial wire debug (SWD) & JTAG interfaces
 - Cortex-M4 Embedded Trace Macrocell™
- 114 I/O ports with interrupt capability
- Up to 15 communication interfaces
 - 3 × I2C interfaces (SMBus/PMBus)
 - 4 USARTs/2 UARTs (10.5 Mbit/s, ISO 7816 interface, LIN, IrDA, modem control)

- 3 SPIs (37.5 Mbits/s), 2 with muxed full-duplex I2S to achieve audio class accuracy via internal audio PLL or external clock
- 2 × CAN interfaces (2.0B Active)
- SDIO interface
- Advanced connectivity
 - USB 2.0 full-speed device/host/OTG controller with on-chip PHY
 - USB 2.0 high-speed/full-speed device/host/OTG controller with dedicated DMA, on-chip full-speed PHY and ULPI
 - 10/100 Ethernet MAC with dedicated DMA: supports IEEE 1588v2 hardware, MII/RMII
- 8- to 14-bit parallel camera interface up to 54 Mbytes/s
- True random number generator
- CRC calculation unit
- 96-bit unique ID
- RTC: subsecond accuracy, hardware calendar

For comprehensive information on the microcontroller visit the ST's web page for a datasheet.

At the moment of writing the microcontroller datasheet can be found at the following link:

<http://www.st.com/st-web-ui/static/active/en/resource/technical/document/datasheet/DM00037051.pdf>

CHAPTER 5 CONTROL CIRCUITRY AND HARDWARE MODULES

5. Introduction to the chapter

Here you can find information about reset circuit and quartz crystals locations, the power supply circuit is discussed.

5.1 Reset

The reset circuit is connected to pin #7 (NRST) of the STM32F405RG microcontroller. STM32-H405's reset circuit includes R8 (10 k Ω), C19 (100nF) and a RESET button.

The reset signal is also available on pin #25 of the EXT1 header. It is also available at pin #15 of the JTAG connector.

5.2 Clocks

There are two quartz crystals available on the board:

8 MHz quartz crystal Q1 is connected to pins 5 and 6 of the ARM microcontroller.

Quartz crystal Q2 is a 32768Hz RTC (real-time clock) and it is connected to microcontroller's pins 3 and 4.

5.3 Power supply circuit

The power supply circuit of STM32-H405 allows the board to be powered by three sources.

The most used interface for powering is the USB type B connector. It works at 5V DC.

The board can also be powered via the on-board JTAG connector. In that case the board receives 3.3V DC from the debugger tool.

Finally, the board can be powered from the EXT headers. The best location to power the board would be pins #26 (+5V DC) and #26 (GND) from the EXT2 connector. Double check the pin locations before providing the power.

The board consumes around 0.2W (e.g. 0.04A at 5V) with both LEDs on.

By default, if you have successfully powered the board both LEDs would turn on. In case you have modified the software the green LED might not turn on since it is initialized by the code loaded on-board. The red LED should always turn on upon powering. Note that it is possible to have the PWR LED on even if there isn't enough power for proper operation of the board and all the peripherals currently connected.

CHAPTER 6 CONNECTORS AND PINOUT

6. Introduction to the chapter

In this chapter are presented the connectors that can be found on the board all together with their pinout and notes about them. Jumpers functions are described. Notes and info on specific peripherals are presented. Notes regarding the interfaces are given.

6.1 USB connector

The USB type B connector allows you to access the USB functionality of STM32-H405. This connector is can be used to power the board. The connector is sturdy and typically lasts much longer during extensive use compared to the USB mini or USB micro connectors.

Note the DFU bootloader uses the USB port.

The signals follow the familiar and standard USB pattern:

USB Type B	
PIN#	SIGNAL NAME
1	+5V_USB
2	USBDM
3	USBDP
4	GND

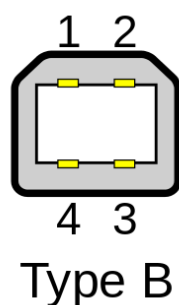

6.2 JTAG/SWD debug connector

The board can be debugged from the 20-pin JTAG connector either by a debugger with compatible connector. The on-board JTAG connector has 0.1" step of its pins. Below is the table with the signals of the JTAG. This interface can be used with the Olimex's OpenOCD debuggers. It is also compatible with most of the ARM debuggers available on the market.

JTAG/SWD debug connector			
Pin #	Signal Name	Pin #	Signal Name
1	3.3V	2	3.3V
3	TRST	4	GND
5	TDI	6	GND
7	TMS	8	GND
9	TCK	10	GND
11	GND	12	GND
13	TDO	14	GND
15	RST	16	GND
17	GND	18	GND
19	GND	20	GND

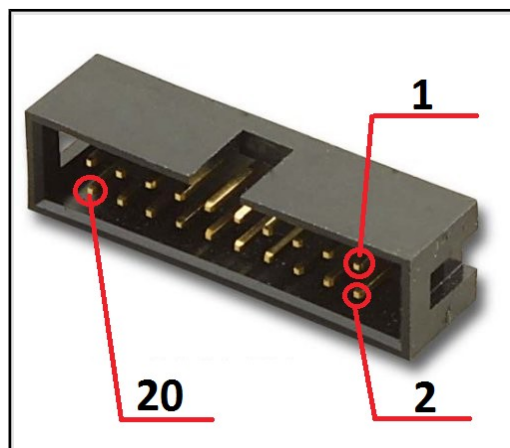

6.3 EXT connectors

At the bottom of the board there are two extension rows of pins. These 2 x 26-pin connectors combine different processor ports and provide very nice GPIO option – you can interface the signals exposed with your breadboarding wires; you can use them as headers; you can take signal readings; etc.

The distance between two pins from the same row is 0.1". The distance between the two EXT connectors is exactly 1".

Refer to sub-chapter 2.3 “EXT pinout (bottom view)” for visual representation of each pin of the connectors.

6.3.1 EXT1 header

EXT1 HEADER			
PIN #	STM32H405 PIN	PIN #	STM32H405 PIN
1	PA11	2	PA8
3	PA12	4	PA9
5	3.3V (VDD)	6	GND
7	PA10	8	PC10
9	PC11 (DISC)	10	PC12 (LED)
11	PD2	12	PB5
13	PB6	14	PA6
15	PB7	16	PB8
17	PB9	18	PA5
19	PC0	20	PC1
21	PB0	22	PA7
23	VBAT	24	PC13
25	RST	26	PB1

6.3.2 EXT2 header

EXT2 HEADER			
PIN #	STM32H405 PIN	PIN #	STM32H405 PIN
1	VDDA	2	PC2
3	VSS (AGND)	4	PA0
5	3.3V (VDD)	6	GND
7	PA2	8	PA1
9	PC3	10	PA3
11	PA4	12	PC4(USB_P)
13	PC5	14	PB10
15	PB11	16	PB13
17	PB12	18	PB14
19	PB15	20	PC6
21	PC7	22	PC8
23	+5V_USB	24	PC9
25	GND_VSS	26	VIN

6.4 Jumper description

Please note that all of the jumpers on the board are SMD type. If you feel insecure in your soldering/cutting technique it is better not to adjust the SMD jumpers.

6.4.1 BOOT memory select jumpers

B1_H/B1_L and B0_H/B0_L are SMD jumpers which define the initial boot default priority of the microcontroller (aka which memory to boot from). By default they are set so that the board would boot from the user Flash memory.

Notice that these two jumpers must be moved together – they are responsible for the boot mode if bootloader is present. The board can search for bootloader on three places – either the user Flash memory, the System memory, or the Embedded SRAM.

By default, B0_H/B0_L is set to position B0_L; the other jumper B1_H/B1_L is set to B1_L – in this configuration the board will try to boot from user Flash memory.

To boot from the system memory you need to change the position of B0_H/B0_L jumper to position B0_H. The boot loader is located in system memory (if you want to program the board via the USB and DFU use software – use this mode).

Changing both high positions (B0_H/B0_L to B0_H; and B1_H/B1_L to B1_H) would attempt to boot from the Embedded SRAM.

Refer to the “STM32 microcontroller system memory boot mode” document (“AN2606”) for more information about the bootloader available on STM32F4xx microcontrollers.

6.4.2 R-T jumper

If you close this jumper RST and TRST at the JTAG will be connected.

The default R-T position is open.

6.4.3 VBAT signal and jumper

The VBAT pin supplies the RTC, the backup registers and the backup SRAM. This VBAT pin allows to power the device VBAT domain from an external battery, an external supercapacitor, or from VDD when no external battery and no external supercapacitor are present. VBAT operation is activated when VDD is not present. The VBAT pin supplies the RTC, the backup registers and the backup SRAM. By default VBAT jumper is closed which connects the VBAT microcontroller pin to the 3.3V line of the board.

VBAT signal is available at pin #23 of EXT1 header – this is a good place to connect a back-up battery that provides voltage in the (2.0-3.3)V range but you would need to open VBAT jumper!

Important! Be careful when you have battery for VBAT and another source of power applied to the board simultaneously. If you connect additional battery to the VBAT line on the EXT1 header without opening the VBAT jumper you would damage the board – the battery voltage would meet the 3.3V line! You can disconnect the jumper and place two opposing Schottky diodes – one on the pads of the jumper and the other between the battery and the EXT pins. This would allow you to use simultaneously external power supply and back-up battery. The diodes should be something like 1N5817, 1N5818, 1N5819.

Please find more information about VBAT in the user's manual of STM32F405RG.

The default VBAT position is closed.

6.4.4 LED_E

Opening this jumper will disable the user LED.

The default position is closed.

6.4.5 USBP_E

Opening this jumper would disable the option to power the board from the USB connector.

The default position is closed.

6.5 Additional hardware components

The hardware components below are mounted on STM32-H405 but are not discussed above. These are listed here for completeness:

RESET button – used for hardware reset of the board; typically cannot be re-programmed; connected to STM32F405's pin #7 (NRST)

BUT button – customizable button; can be re-programmed by the user – connected to STM32F405's pin #14 (PA0); also available at pin #4 of the EXT2 header

PWR LED – indicates when the board is powered; cannot be re-programmed; it is not connected to the main microcontroller

STAT LED – customizable LED; can be re-programmed by the user – connected to STM32F405's pin #53 (PC12); also available at pin #10 of the EXT1 header; this LED can also be disabled if you disconnect jumper LED_E; the jumper pads can also be used for measurements

CHAPTER 7 BLOCK DIAGRAM AND MEMORY

7. Introduction to the chapter

On the next page you can find a memory map for this family of processors. It is strongly recommended to refer to the original datasheet released by STMicroelectronics for one of higher quality.

7.1 Processor family block diagram

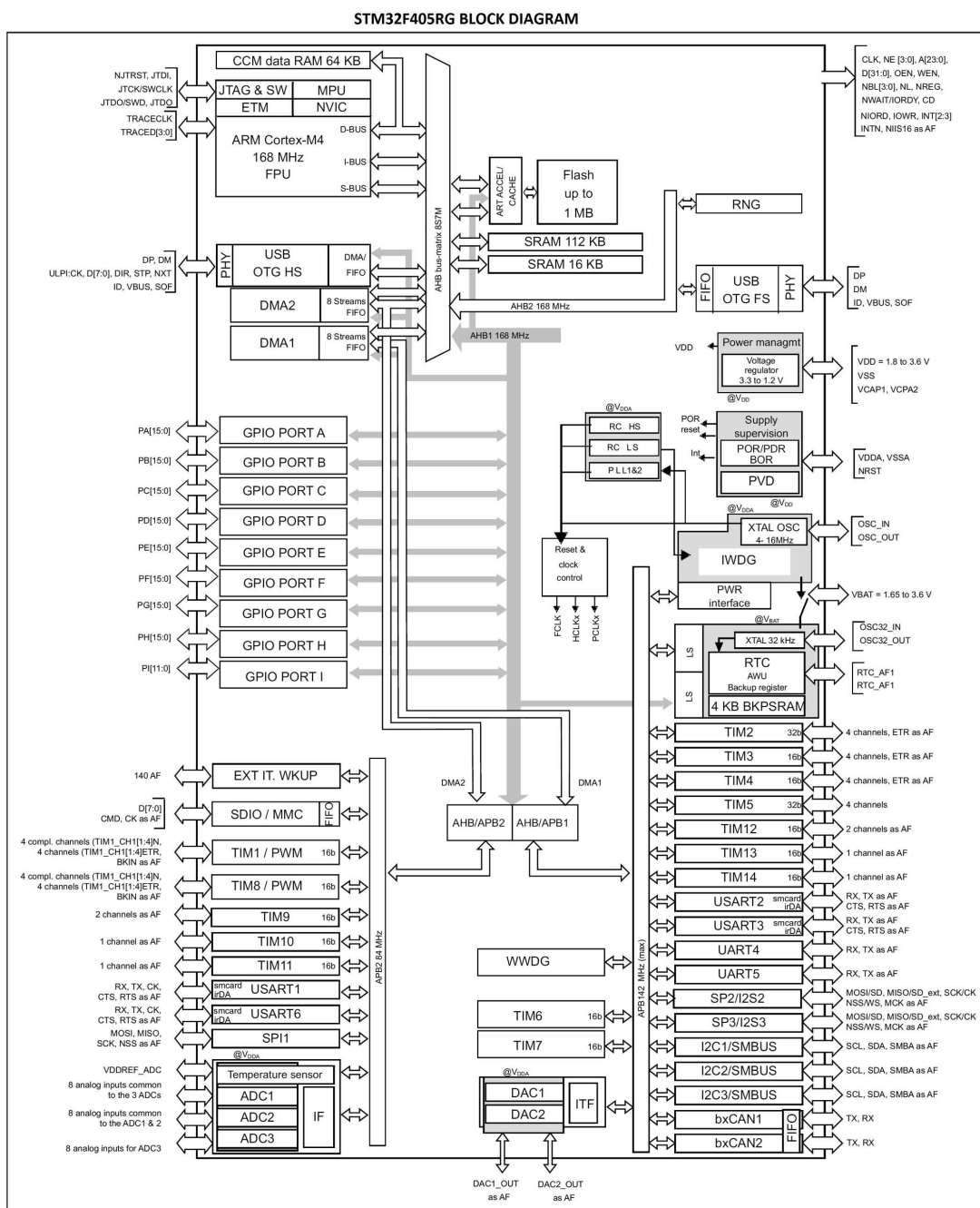

CHAPTER 8 SCHEMATICS

8. Introduction to the chapter

In this chapter are located the schematics describing logically and physically STM32-H405.

8.1 Eagle schematic

STM32-H405 schematic is visible for reference here. You can also find them on the web page for STM32-H405 at our site: <https://www.olimex.com/Products/ARM/ST/STM32-H405/>

They are located in HARDWARE section.

The EAGLE schematic is situated on the next page for quicker reference.

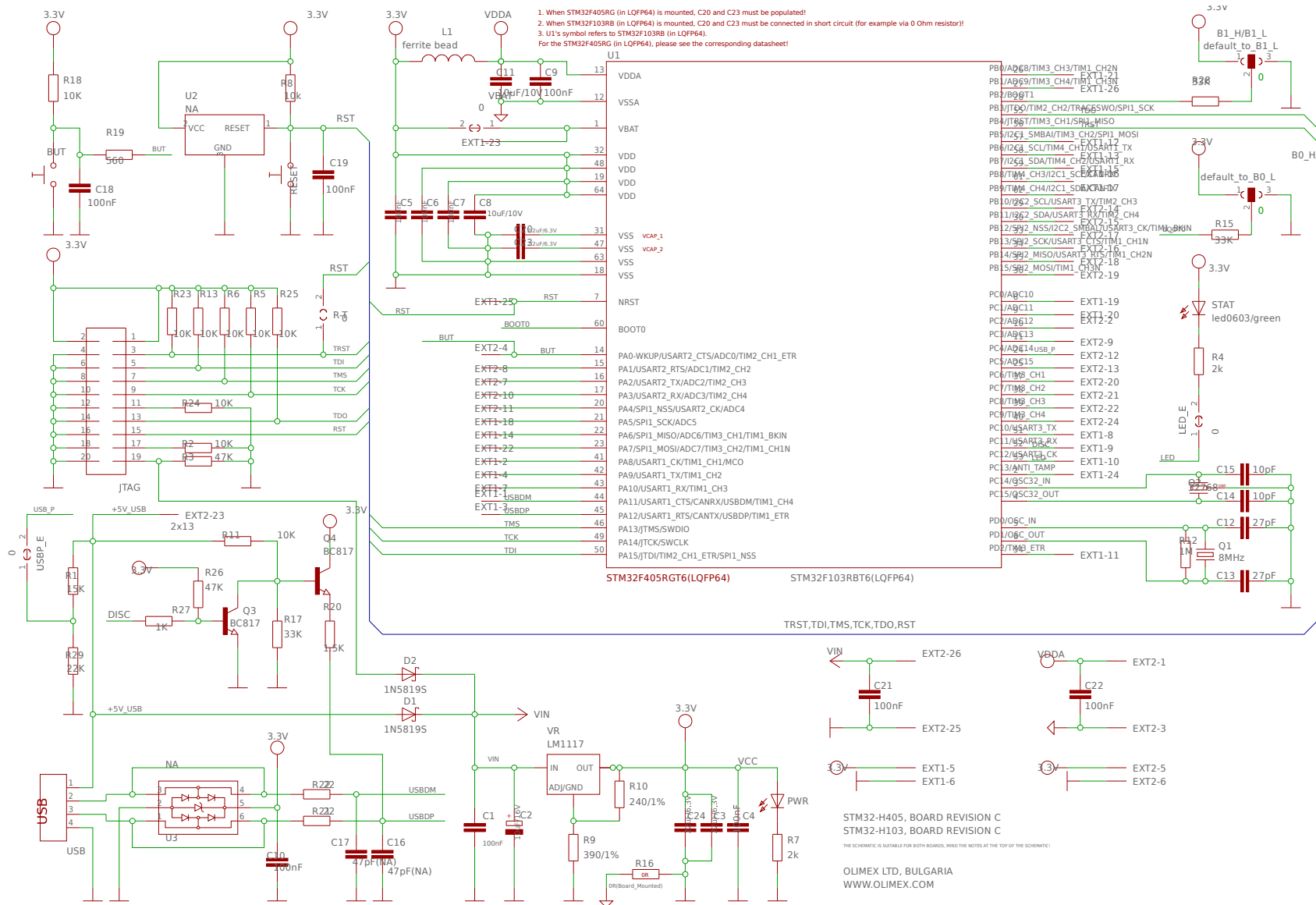

8.2 Physical dimensions

Note that all dimensions are in thousandths of an inch (mil).

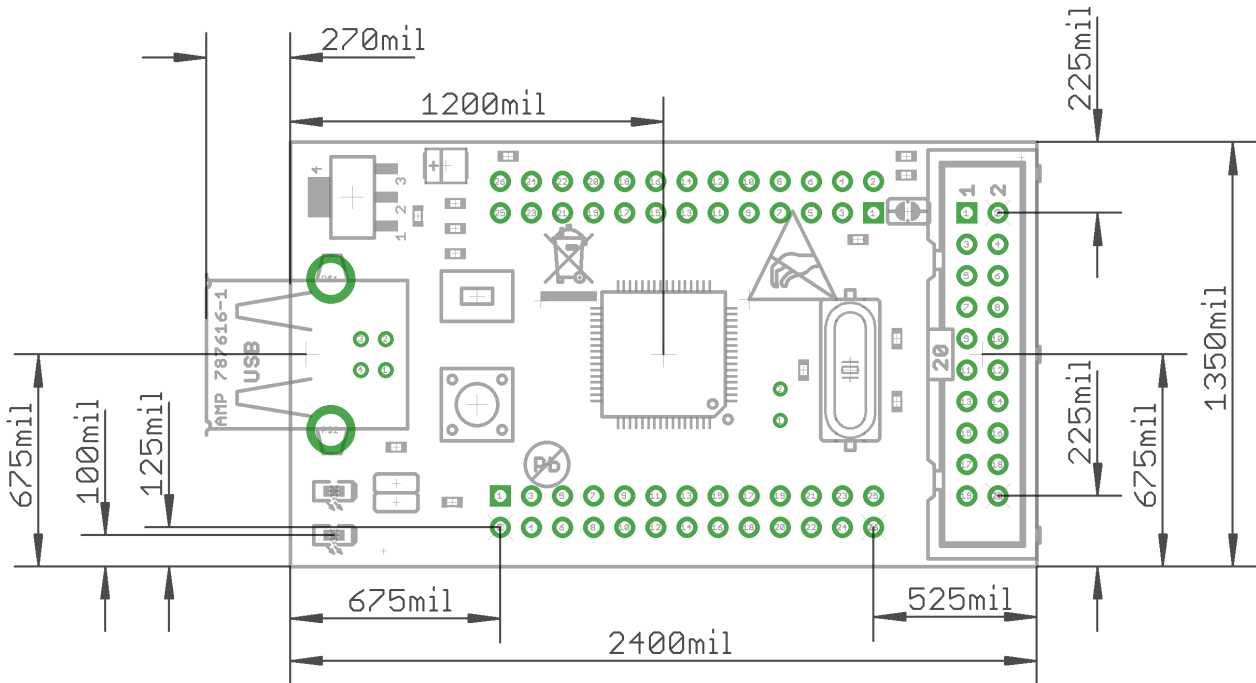

CHAPTER 9 REVISION HISTORY AND SUPPORT

9. Introduction to the chapter

In this chapter you will find the current and the previous version of the document you are reading. Also the web-page for your device is listed. Be sure to check it after a purchase for the latest available updates and examples.

9.1 Document revision

Revision, Date	Changes	Modified pages
A, 26.11.15	Initial release	All
B, 20.04.16	Fixed and improved the information about VBAT jumper	16, 21

9.2 Board revision

Revision, Date	Revision notes
C, 21.02.14	Initial release

9.3 Useful web links and purchase codes

The web page you can visit for more info on your device is:

<https://www.olimex.com/Products/ARM/ST/STM32-H405/>

The official Olimex forums are located here: <https://www.olimex.com/forum>

ORDER CODES:

STM32-H405 – the version of the board discussed in this document

STM32-P405 – a similar board with more peripherals

STM32-405STK – a similar board with even more peripherals

ARM-USB-TINY-H – OpenOCD compatible high-speed debugger/programmer with JTAG interface

ARM-USB-OCD-H – OpenOCD compatible debugger/programmer with JTAG interface, protection buffers and better power supply circuit

How to order?

You can order directly from our web-shop or via any of our distributors. List of Olimex distributors may be found here: <https://www.olimex.com/Distributors/>

Please check <https://www.olimex.com/> for more information.

9.4 Product support

For product support, hardware information and error reports mail to: support@olimex.com. All document or hardware feedback is welcome. Note that we are primarily a hardware company and our software support is limited. Please consider reading the paragraph below about the warranty of Olimex products.

All goods are checked before they are sent out. In the unlikely event that goods are faulty, they must be returned, to OLIMEX at the address listed on your order invoice.

OLIMEX will not accept goods that have clearly been used more than the amount needed to evaluate their functionality.

If the goods are found to be in working condition, and the lack of functionality is a result of lack of knowledge on the customers part, no refund will be made, but the goods will be returned to the user at their expense.

All returns must be authorized by an RMA Number. Email support@olimex.com for authorization number before shipping back any merchandise. Please include your name, phone number and order number in your email request.

Returns for any unaffected development board, programmer, tools, and cables permitted within 7 days from the date of receipt of merchandise. After such time, all sales are considered final.

Returns of incorrect ordered items are allowed subject to a 10% restocking fee. What is unaffected? If you hooked it to power, you affected it. To be clear, this includes items that have been soldered to, or have had their firmware changed. Because of the nature of the products we deal with (prototyping electronic tools) we cannot allow returns of items that have been programmed, powered up, or otherwise changed post shipment from our warehouse.

All returned merchandise must be in its original mint and clean condition. Returns on damaged, scratched, programmed, burnt, or otherwise 'played with' merchandise will not be accepted.

All returns must include all the factory accessories which come with the item. This includes any In-Circuit-Serial-Programming cables, anti-static packing, boxes, etc.

With your return, enclose your PO#. Also include a brief letter of explanation of why the merchandise is being returned and state your request for either a refund or an exchange. Include the authorization number on this letter, and on the outside of the shipping box.

Please note: It is your responsibility to ensure that returned goods reach us. Please use a reliable form of shipping. If we do not receive your package we will not be held liable.

Shipping and handling charges are not refundable. We are not responsible for any shipping charges of merchandise being returned to us or returning working items to you.

The full text might be found at <https://www.olimex.com/wiki/GTC#Warranty> for future reference.

X-ON Electronics

Largest Supplier of Electrical and Electronic Components

Click to view similar products for [Development Boards & Kits - ARM category](#):

Click to view products by [Olimex manufacturer](#):

Other Similar products are found below :

[OM13090UL](#) [Raspberry Pi 4 Model B,8GB](#) [YR0K77210B000BE](#) [B-U585I-IOT02A](#) [NUCLEO-WL55JC1](#) [ZDSD-Pinboard](#) [081ZYKFB](#)
[LKS32MC034DOF6Q8-k](#) [LKS32MC038Y6P8B-K](#) [LKS32MC071DOC8T8-K](#) [LKS32MC071CBT8-K](#) [LKS32MC038Y6P8-k](#) [Ai-WB2-32S-Kit](#) [GD32E103T-START](#) [GD32L233K-START](#) [M6G2C-256LI](#) [YT37](#) [LKS32MC033H6P8B-K](#) [VC-02-Kit_EN](#) [Ra-08H-Kit](#) [Hi-12FL-Kit](#)
[PB-03M-Kit](#) [Ai-WB2-13-Kit](#) [PB-03F-Kit](#) [Ra-08-Kit](#) [Hi-07SL-Kit](#) [Hi-07S-Kit](#) [PB-03-Kit](#) [Hi-12F-Kit](#) [AT-START-F437](#) [AT-START-F407](#)
[E104-BT40-TB](#) [FT8132Q-3HALL-FOC+EMF](#) [FU6832L-TGB-DEMO](#) [APM32F072VBT6](#) [APM32F091VC MINI](#) [APM32F407IG-MINIBOARD](#) [APM32F051R8 MINI](#) [GD32FPRT-START](#) [GD32407H-START-1](#) [GD32E503V-EVAL](#) [GD32403V-START-1](#) [EPC1EVK-ECGPPG\(FS\)](#) [NS4EVKA-LC](#) [ENS1EVKD](#) [.ENS1EVKB](#) [ENS1EVKE](#) [HLK-7621-ALL-SUIT](#) [HLK-V20-SUIT](#) [JLC-DIG01](#)