

A20-OLINUXINO-LIME2

Open-source single-board Android/Linux mini-computer

USER'S MANUAL

Document revision H, May 2022
Designed by OLIMEX Ltd, 2014



All boards produced by Olimex LTD are ROHS compliant

DISCLAIMER

© 2022 Olimex Ltd. Olimex®, logo and combinations thereof, are registered trademarks of Olimex Ltd. Other product names may be trademarks of others and the rights belong to their respective owners.

The information in this document is provided in connection with Olimex products. No license, express or implied or otherwise, to any intellectual property right is granted by this document or in connection with the sale of Olimex products.

This work is licensed under the Creative Commons Attribution-ShareAlike 3.0 Unported License. To view a copy of this license, visit <http://www.creativecommons.org/licenses/by-sa/3.0/>.

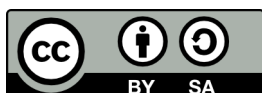

This hardware design by Olimex LTD is licensed under a Creative Commons Attribution-ShareAlike 3.0 Unported License.

The software is released under GPL.

It is possible that the pictures in this manual differ from the latest revision of the board.

The product described in this document is subject to continuous development and improvements. All particulars of the product and its use contained in this document are given by OLIMEX in good faith. However all warranties implied or expressed including but not limited to implied warranties of merchantability or fitness for purpose are excluded. This document is intended only to assist the reader in the use of the product. OLIMEX Ltd. shall not be liable for any loss or damage arising from the use of any information in this document or any error or omission in such information or any incorrect use of the product.

This evaluation board/kit is intended for use for engineering development, demonstration, or evaluation purposes only and is not considered by OLIMEX to be a finished end-product fit for general consumer use. Persons handling the product must have electronics training and observe good engineering practice standards. As such, the goods being provided are not intended to be complete in terms of required design-, marketing-, and/or manufacturing-related protective considerations, including product safety and environmental measures typically found in end products that incorporate such semiconductor components or circuit boards.

Olimex currently deals with a variety of customers for products, and therefore our arrangement with the user is not exclusive. Olimex assumes no liability for applications assistance, customer product design, software performance, or infringement of patents or services described herein.

THERE IS NO WARRANTY FOR THE DESIGN MATERIALS AND THE COMPONENTS USED TO CREATE A20-OLINUXINO-LIME2 AND A20-OLINUXINO-LIME2-4GB. THEY ARE CONSIDERED SUITABLE ONLY FOR, RESPECTIVELY, A20-OLINUXINO-LIME2 OR A20-OLINUXINO-LIME2-4GB.

Table of Contents

<u>DISCLAIMER.....</u>	<u>2</u>
<u>CHAPTER 1: OVERVIEW.....</u>	<u>5</u>
<u>1. Introduction to the chapter.....</u>	<u>5</u>
<u>1.1 Features.....</u>	<u>5</u>
<u>1.2 Target market and purpose of the board.....</u>	<u>6</u>
<u>1.3 Board variants.....</u>	<u>6</u>
<u>1.4 Board version used in the manual.....</u>	<u>7</u>
<u>1.5 Document organization.....</u>	<u>8</u>
<u>CHAPTER 2: SETTING UP THE OLINUXINO BOARD.....</u>	<u>9</u>
<u>2. Introduction to the chapter.....</u>	<u>9</u>
<u>2.1 Electrostatic and electrical polarity warning.....</u>	<u>9</u>
<u>2.2 Requirements.....</u>	<u>9</u>
<u>2.3 Powering the board.....</u>	<u>11</u>
<u>2.4 Button functions.....</u>	<u>12</u>
<u>2.5 Software support.....</u>	<u>12</u>
<u>CHAPTER 3: A20-OLINUXINO-LIME2 BOARD DESCRIPTION.....</u>	<u>13</u>
<u>3. Introduction to the chapter.....</u>	<u>13</u>
<u>3.1 Layout (top view).....</u>	<u>13</u>
<u>3.2 Layout (bottom view).....</u>	<u>14</u>
<u>CHAPTER 4: THE ALLWINNER A20 MICROCONTROLLER.....</u>	<u>15</u>
<u>4. Introduction to the chapter.....</u>	<u>15</u>
<u>4.1 The processor.....</u>	<u>15</u>
<u>4.2 Block diagram.....</u>	<u>16</u>
<u>CHAPTER 5: CONTROL CIRCUITY.....</u>	<u>17</u>
<u>5. Introduction to the chapter.....</u>	<u>17</u>
<u>5.1 Reset.....</u>	<u>17</u>
<u>5.2 Clocks.....</u>	<u>17</u>
<u>5.3 Power supply circuit.....</u>	<u>17</u>
<u>CHAPTER 6: CONNECTORS AND PINOUT.....</u>	<u>18</u>
<u>6. Introduction to the chapter.....</u>	<u>18</u>
<u>6.1 UART0 interface.....</u>	<u>18</u>
<u>6.2 MicroSD card connector.....</u>	<u>18</u>
<u>6.2.1 SD/MMC1 slot.....</u>	<u>19</u>
<u>6.3 PWR jack.....</u>	<u>20</u>
<u>6.4 USB OTG.....</u>	<u>20</u>
<u>6.5 USB HOST connectors.....</u>	<u>22</u>
<u>6.6 Gigabit Ethernet.....</u>	<u>23</u>
<u>6.7 HDMI connector.....</u>	<u>24</u>
<u>6.8 SATA connector and power.....</u>	<u>25</u>

6.9 GPIO connectors.....	25
6.9.1 GPIO-1 (General Purpose Input/Output) 40pin connector.....	26
6.9.2 GPIO-2 (General Purpose Input/Output) 40pin connector.....	28
6.9.3 GPIO-3 (General Purpose Input/Output) 40pin connector.....	29
6.9.4 GPIO-4 (General Purpose Input/Output) 20pin connector.....	29
6.10 LCD CON 40pin connector.....	30
6.11 Jumper description.....	32
6.12 Additional hardware components.....	33
CHAPTER 7: SCHEMATICS.....	34
7. Introduction to the chapter.....	34
7.1 Eagle schematic.....	34
7.2 Physical dimensions.....	35
CHAPTER 8: REVISION HISTORY AND SUPPORT.....	36
8. Introduction to the chapter.....	36
8.1 Document revision.....	36
8.2 Board revision.....	37
8.3 Useful web links and purchase codes.....	37
8.4 Frequently asked questions.....	39
8.5 Product support.....	43

CHAPTER 1: OVERVIEW

1. Introduction to the chapter

Thank you for choosing this single board computer from Olimex! This document provides a user's guide for the Olimex A20-OLinuXino-LIME2 board. As an overview, this chapter gives the scope of this document and lists the board's features. The document's organization is then detailed.

The A20-OLinuXino-LIME2 development board enables code development of applications running on the A20 microcontroller, manufactured by Allwinner Technology from China.

OLinuXino is an open-source, open-hardware project and all design files are available to the customer.

1.1 Features

The board has the following set of features:

- A20 Cortex-A7 dual-core ARM Cortex-A7 CPU and dual-core Mali 400 GPU
- 1GB DDR3 RAM memory
- Gigabit Ethernet
- **8GB or 16GB memory (available, respectively in T2-OLinuXino-LIME2-e8Gs16M-IND and A20-OLinuXino-LIME2-e16Gs16M)**
- **8GB NAND FLASH memory (available only in A20-OLinuXino-LIME2-n8GB)**
- SATA connector with 5V SATA power jack
- Native HDMI interface with standard connector
- Capable of FullHD (1080p) video playback
- 2x USB Low-Full-High-Speed hosts with power control and current limiter
- USB-OTG with power control and current limiter
- LiPo Battery connector with battery-charging capabilities
- LCD row of pins (0.05" step)
- 160 GPIOs on four GPIO rows of pins (0.05" step)
- MicroSD card connector
- DEBUG-UART connector for console debug with USB-SERIAL-CABLE-F
- Status LED
- Battery charge status LED
- Power LED
- 2KB EEPROM for MAC address storage and more
- 2 BUTTONS with ANDROID functionality + RESET button
- 2 mount holes
- 5V input power supply, noise immune design
- PCB dimensions: (84 × 60)mm ~ (3.3 × 2.4)"

1.2 Target market and purpose of the board

The boards from the OLinuXino family are easy to setup and powerful. It is possible to use them in almost any application as a host board. They are suitable for embedded programming enthusiasts, Linux and Android gadget fans (they can just use the board as a media center or fully functional Linux PC, for instance) and also professionals (since its low cost makes it very good solution for application-orientated embedded systems). The main usage of the board is software embedded development without the urge of understanding perfectly the hardware.

The LIME boards are a special kind of OLinuXino boards – they are as small as possible while maintaining a remarkable stand-alone functionality. The strong points of these boards are the processor speed, the small form factor and the low price-to-productivity ratio.

Customers have full access to the technical documentation of the board. The software is released under General Purpose License and the board is considered open-hardware – all schematics and board design files are available to the customer under the Creative Commons Attribution-ShareAlike 3.0 Unported License.

1.3 Board variants

The board has seven board variants. The difference in the suffix is based on the type and volume of extra flash memory installed on the board. The base version of the board, that comes with NO extra flash memory is named **A20-OLinuXino-LIME2**. These variants with extra flash memory are named: **A20-OLinuXino-LIME2-e16G**, **A20-OLinuXino-n8G**, and **A20-OLinuXino-LIME2-n8GB**. The name consists of the type of the memory and the size of the memory – suffix “**e4GB**” stands for eMMC type of flash with 4GB of size; “**n4GB**” stands for NAND type of flash with 4GB of size.

The **e16G** version comes with 16GB eMMC flash memory that expands the on-board storage available and also allows booting the operating system without the need of a SD card. The eMMC memory comes blank (you would have to upload desired operating system to the eMMC memory).

Exactly the same is the case with the **n4GB** and **n8GB** variants. The **n4GB** and **n8GB** versions come with either 4GB or 8GB extra NAND flash memories expands the on-board storage available and also allows booting the operating system without the need of a SD card. Note that these memories also come blank (you would have to upload desired operating system to the NAND memory).

Currently, there is higher demand for boards with eMMC since seem to require less power, have longer life, corrupt harder. Additionally, the eMMC memories that we use have an industrial temperature range version.

Board variant	Extra Flash	Type of Flash	Size of Flash	Boot Linux from Flash
A20-OLinuXino-LIME2	No	-	-	-
A20-OLinuXino-LIME2-e4GB	Yes	eMMC	4GB	Yes after install script
A20-OLinuXino-LIME2-n4GB	Yes	NAND	4GB	Yes after install script
A20-OLinuXino-LIME2-n8GB	Yes	NAND	8GB	Yes after install script

A20-OLinuXino-LIME2 looks similar to both A20-OLinuXino-LIME and to A10-OLinuXino-LIME. The major differences between A20-OLinuXino-LIME2 and A20-OLinuXino-LIME are:

1. LIME2 has gigabit Ethernet (GbE), compared to the standard 100Mb Ethernet of the LIME.
2. LIME2 design provides double the RAM memory, compared to the LIME design (1024 vs 512).
3. Much better routing of DDR3 memory.
4. Increased the number of layers from 6 in LIME to 8 in LIME2.
5. Corrected pinout of the LCD connector (shields for LIME are not compatible with LIME2)
6. The price tag

Due to the hardware differences listed above the Linux and Android distributions of the LIME2 and LIME boards are not identical. Furthermore, some of the hardware extensions are not compatible with both of the designs. For example, the **A10-OLINUXINO-LIME-UEXT** is **not** compatible with A20-OLinuXino-LIME2 board.

1.4 Board version used in the manual

Revision B boards and resources were used while writing this document. It is possible that they are outdated so it is always recommended to download the latest sources from the GitHub page of the board (<https://github.com/OLIMEX/OLINUXINO/tree/master/HARDWARE>).

Some peripherals, documents or software may be suitable for both the A20-LIME2 and the A20-LIME designs but it is generally advised to use resources for the specific board.

1.5 Document organization

Each section in this document covers a separate topic, organized as follows:

- Chapter 1 is an overview of the board usage and features
 - Chapter 2 provides a guide for quickly setting up the board and software notes
 - Chapter 3 contains the general board diagram and layout
 - Chapter 4 describes the component that is the heart of the board: the A20 – Allwinner processor
 - Chapter 5 is an explanation of the control circuitry associated with the processor
 - Chapter 6 covers the connector pinout, peripherals and jumper description
 - Chapter 7 provides the schematics and the dimensions of the board
 - Chapter 8 contains the revision history, useful links and support information
-
-

CHAPTER 2: SETTING UP THE OLINUXINO BOARD

2. Introduction to the chapter

This section helps you set up the development board for the first time. Please consider first the electrostatic warning to avoid damaging the board, then discover the hardware and software required to operate the board.

The procedure to power up the board is given, and a description of the default board behavior is detailed.

2.1 Electrostatic and electrical polarity warning

A20-OLinuXino-LIME2 is shipped in a protective anti-static package. The board must not be exposed to high electrostatic potentials. A grounding strap or similar protective device should be worn when handling the board. Avoid touching the component pins or any other metallic element.

Ensure that your development board gets attached to properly working hardware. For example, it is common for cheap HDMI monitors to lack grounding. Avoid TVs which have no grounding on their power supply cable! If you can't avoid them try to add the grounding yourself, if this is not possible please use USB-ISO to save your development board from potential over voltage.

If you connect other electrical devices to the LIME2 board make sure that they have equal electrical polarity. For example, when you connect an HDMI cable between a TV and the board it is a good idea to have them both connected to the same electrical source (to the same utility power socket). This might be said for a serial cable connected between a PC and the board's DEBUG port.

In rare cases different polarity might cause hardware damage to the board.

2.2 Requirements

In order to set up the A20-OLinuXino-LIME2 optimally one or more additional items may be used. They might be generally placed in three categories:

Required – items that are needed in order to achieve minimum functionality;

Recommended – items that is good to have in order to be able to interact with the most important of the features of the board;

Additional – items that provide access to additional features or expand the features of the board.

Required items:

- USB type A to USB mini cable – to connect to a personal computer; used for powering the board and uploading new Android image to the NAND memory (if your board has 4GB NAND); can also be used to access the Linux of the board
- Input device – either a mouse/keyboard or touchscreen LCD
- Output device – either HDMI cable + native HDMI monitor/screen/projector; or USB-SERIAL-CABLE-F + personal computer (for Linux and/or Android debugging)
- SD card with compatible image – if you have the board version with NO additional NAND memory you will need it to use one of the images available.

Recommended items:

- External USB hub – to split the USB_HOST mounted on the board; you need that to connect more USB

devices

- External power supply unit – 5V DC, 5W required – for optimal power
- BOX-LIME – a metallic and aesthetic box specially made for the board that protects it from dust and accidental short-circuits
- USB-SERIAL-CABLE-F – for Android/Linux debugging on UART0

Additional items include:

- Small heatsink for the processor – during long video playbacks the A20 processor might heat up
- External 2.5" SATA hard disk drive (proper cables sold separately)
- Ethernet cable for wired Ethernet

Important note on requirements:

The board works with 2.5" SATA hard disks that can be powered by 5V source from the board! For the 3.5" hard disks you would probably need to provide external 12V supply.

It is a very good idea to have a USB-SERIAL-CABLE or similar cable since it allows you to:

1. Change display output settings for Debian easily
2. Debug the board via any personal computer even if there are problems with the video output

Some of the above-suggested items can be purchased by Olimex, for instance:

SY0605E – reliable power supply adapter 50Hz (for EU) 5V/1A for A20-OLinuXino-LIME

SY0605E-CHINA – cheaper power supply adapter 50Hz (for EU) 5V/1A for A20-OLinuXino-LIME

A20-LIME-ANDROID-SD – a tested class 10 micro SD card with the latest (by the time of leaving the Olimex facilities) official Android release

A20-LIME-DEBIAN-SD – a tested class 10 micro SD card with the latest (by the time of leaving Olimex facilities) official Debian Linux release

USB-SERIAL-CABLE-F – female USB serial console cable

USB-MINI-CABLE – standard USB type A to USB type mini cable

A20-OLINUXINO-LIME2-UEXT – GPIO adapter which makes LIME2 GPIOs available in breadboard friendly 0.1" step connectors, needed if you want to connect an older Olimex-made display to the board (newer displays listed below have 0.05" step connector)

CABLE-40-40-10CM – 0.05" step cable for connecting a new display to the board

LCD-OLINUXINO-4.3TS – low-cost 4.3" LCD display with touchscreen component – 480×272

LCD-OLINUXINO-7TS – low-cost 7" LCD display with optional touchscreen component – 800×480

LCD-OLINUXINO-10TS – low-cost 10" LCD display with optional touchscreen component – 1024×600

LCD-OLINUXINO-15.6 – low-cost 15.6" LCD display – 1366×768

LCD-OLINUXINO-15.6FHD – low-cost Full HD 15.6" LCD display – 1920×1080

CABLE-IDC40-15cm – 0.1" step cable for connecting an LCD to LCD_CON

SATA-HDD-2.5-500GB – 500GB 2.5" SATA hard disk

SATA-CABLE-SET – cables that allow the connection of a 2.5" hard disk to the board

ALUMINIUM-HEATSINK-20×20×6MM – heatsink radiator for better processor heat dissipation

2.3 Powering the board

There are three possible ways to power sufficiently A20-OLinuXino-LIME2:

- via external supply providing 5V DC at the power jack (1A required, 2A recommended);
- from 3.7V Li-Po battery via the LIPO_BAT;
- via 5VEXT pad at the bottom.

Important: The 3.3V and 5V pins at the GPIO headers are only outputs! Do not power A20-OLinuXino-LIME2 from the headers!

Important: You can't sufficiently power the A20-OLinuXino-LIME2 board from the USB port! Doing so will lead to instability, no matter how powerful your supply might be!

Depending on your preferred way of powering you might need additional hardware.

The typical consumption of A20-OLinuXino-LIME2 is between 400mA and 650mA depending on the current load.

If the board has entered power-down state you can bring it back without restart using the PWR_BUT. The PWR_BUT is also used to start the board when powered from a Li-Po battery on the battery connector.

Sometimes when starting Android it is possible the board to enter battery save mode even before booting fully. Especially, if you have turned off the board without quick boot mode enabled. In this case you should press the PWR button for at least 5 seconds which would allow the board to start.

For the European customers we sell two power supply adapters, please check chapter 2.2. We also sell USB OTG to USB type A cables if you lack such.

The default username/password combination for the default Linux image on the SD card (if purchased) is: root/olimex.

Note that it is normal that when the board is powered some integrated circuits might appear hotter than others. This is perfectly normal for some chips – for instance – voltage regulators and the main processor.

2.4 Button functions

The below three buttons usually are supported under both Android and Debian:

PWR – used to perform software turn off, software turn on; used to turn on board when powered by battery – has to be held down for at least 5 seconds to perform each action

RESET – used for hardware reset of the board

RECOVERY – used to wake up the board from sleep

It is recommended to always make a soft “turn off” of the board. If that is not possible then please hold PWR button down for a few seconds to “turn off the board”. Then you are free to remove the power supply. If you disconnect the power supply (the battery or the power jack) before turning off the board you may corrupt your SD card. If you have placed NAND memory you can corrupt the image on the NAND memory.

2.5 Software support

We maintain Linux and Android images for SD card which might be downloaded for free and modified as the user wishes.

We build own Linux image called Olimage, it is highly recommended to check this document for start up tips and more info about our Linux:

<https://github.com/OLIMEX/OLINUXINO/blob/master/DOCUMENTS/OLIMAGE/Olimage-guide.pdf>

The latest images and updates are featured at the wiki article of the device: <https://www.olimex.com/wiki/A20-OLinuXino-LIME2>.

We usually try to provide details on how to build the Linux and the Android images at our GitHub page: <https://github.com/OLIMEX/OLINUXINO/tree/master/SOFTWARE/A20>

Another useful place is the Olimex forums where a lot of people share their experience and advice: <https://www.olimex.com/forum/>

The official images are a constant work-in-progress – newer releases are packed with better hardware support, newer kernels and extra features.

You are more than welcome to send or share your suggestions and ideas at our e-mail, the public forums or irc channel. We would attempt to help in almost every case. We listen to the feedback and if the majority of users suggest a software change or update we try to implement such. Customer feedback is very important for the overall state of the software support. However, do not expect full Linux or Android software support.

We can share our experience. We can give you full details for things we have tried. We can point you to a resource or a guide. We can give you general directions to solving a specific problem or places to look for more information. However, we won't install a piece of software for you or write custom program for you. We won't provide a specific software solution to a specific software problem.

CHAPTER 3: A20-OLINUXINO-LIME2 BOARD DESCRIPTION

3. Introduction to the chapter

Here you get acquainted with the main parts of the board. Note the names used on the board might differ from the names used below to describe them. For the actual names check the A20-OLinuCino-LIME2 board itself.

3.1 Layout (top view)

The picture below shows the top side of the board and highlights the most important parts:

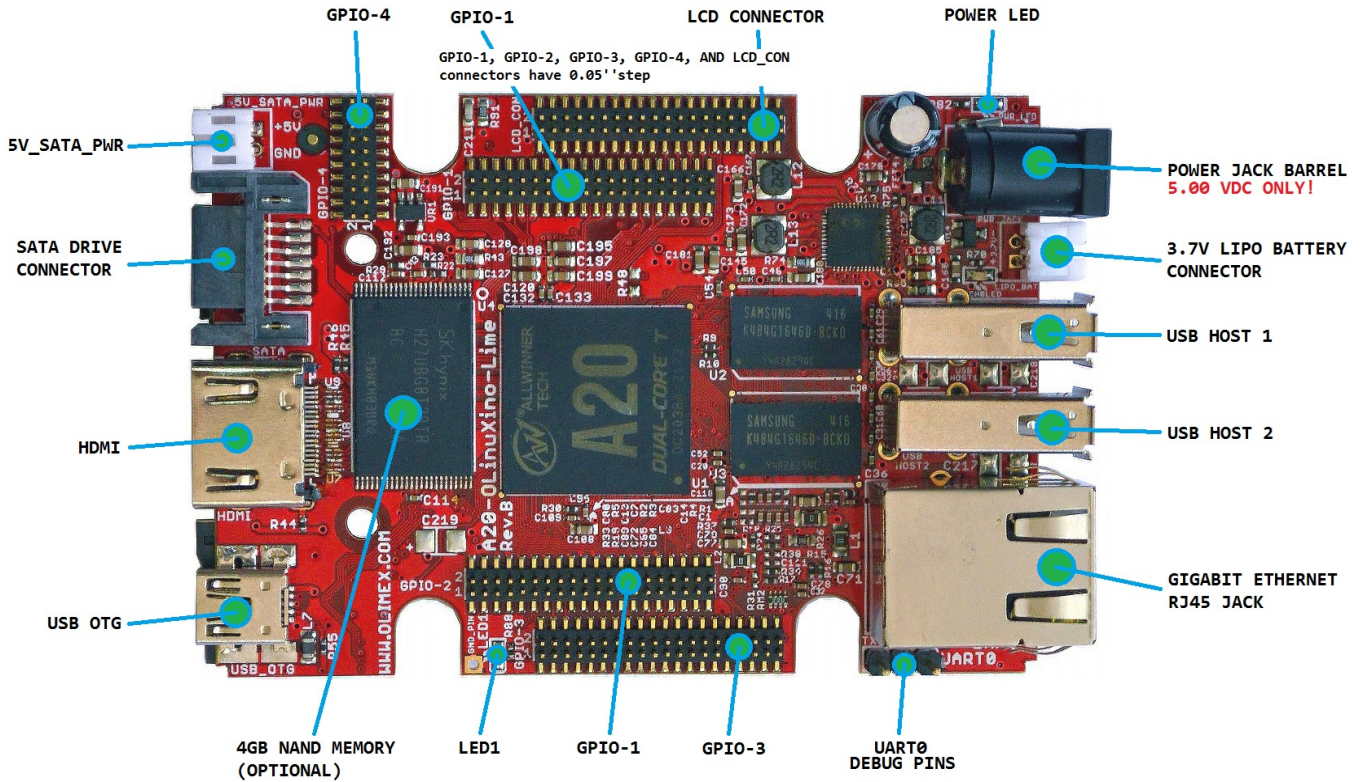

3.2 Layout (bottom view)

At the bottom are located mainly the buttons and microSD card connector.

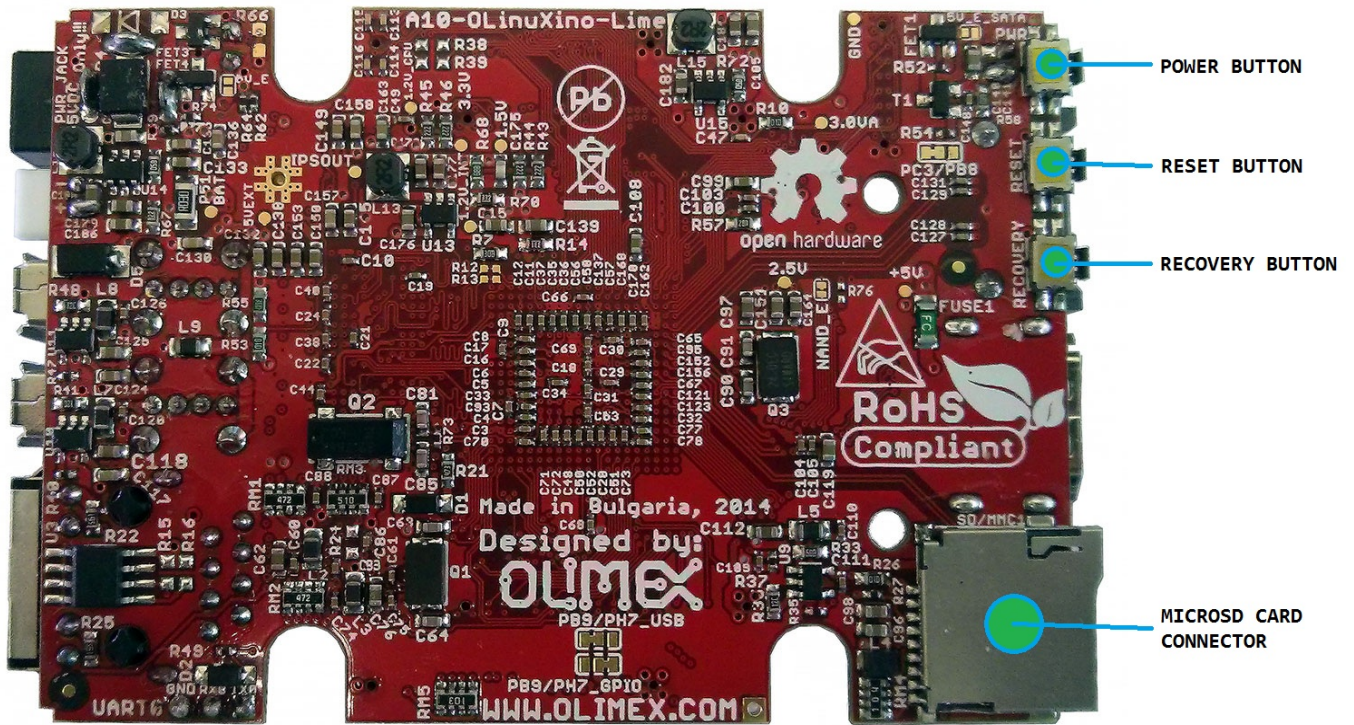

CHAPTER 4: THE ALLWINNER A20 MICROCONTROLLER

4. Introduction to the chapter

In this chapter is located the information about the heart of OLinuXino – its microcontroller. The information is a modified version of the datasheet provided by its manufacturers.

4.1 The processor

The features of the A20 processor according to the manufacturer Allwinner:

- CPU
 - ARM® Cortex™-A7 Dual-Core
- GPU
 - ARM® Mali400MP2
 - Complies with OpenGL ES 2.0/1.1
- VIDEO
 - HD H.264 2160p video decoding
 - Multi-format FHD video decoding, including Mpeg1/2, Mpeg4 SP/ASP GMC, H.263, H.264, VP6/8, AVS jizun, Jpeg/Mjpeg, etc.
 - H.264 High Profile 1080p@30fps or 720p@60fps encoding
 - 3840×1080@30fps 3D decoding, BD/SBS/TAB/FP supported
 - Complies with RTSP, HTTP, HLS, RTMP, MMS streaming media protocols
- DISPLAY
 - Supports multi-channel HD display
 - Integrated HDMI 1.4 transmitter with HDCP support
 - CPU/RGB/LVDS LCD interface
 - Supports CVBS/YPbPr/VGA
 - Integrated TV decoder
- CAMERA
 - Integrated parallel 8-bit I/F YUV sensor
 - Integrated 24-bit parallel YUV 444 I/F
 - Supports 5M CMOS sensor
 - Supports dual sensors
- AUDIO
 - Integrated HI-FI 100dB Audio Codec
 - Dual analog mic amplifiers

More information can be found on Allwinner's web site at the following web-address:

<http://www.allwinnertech.com/en/product/A20.html>

A good source of information on the processor is the linux sunxi wiki article: <http://linux-sunxi.org/A20>.

4.2 Block diagram

The block diagram is taken from Allwinner's web-site.

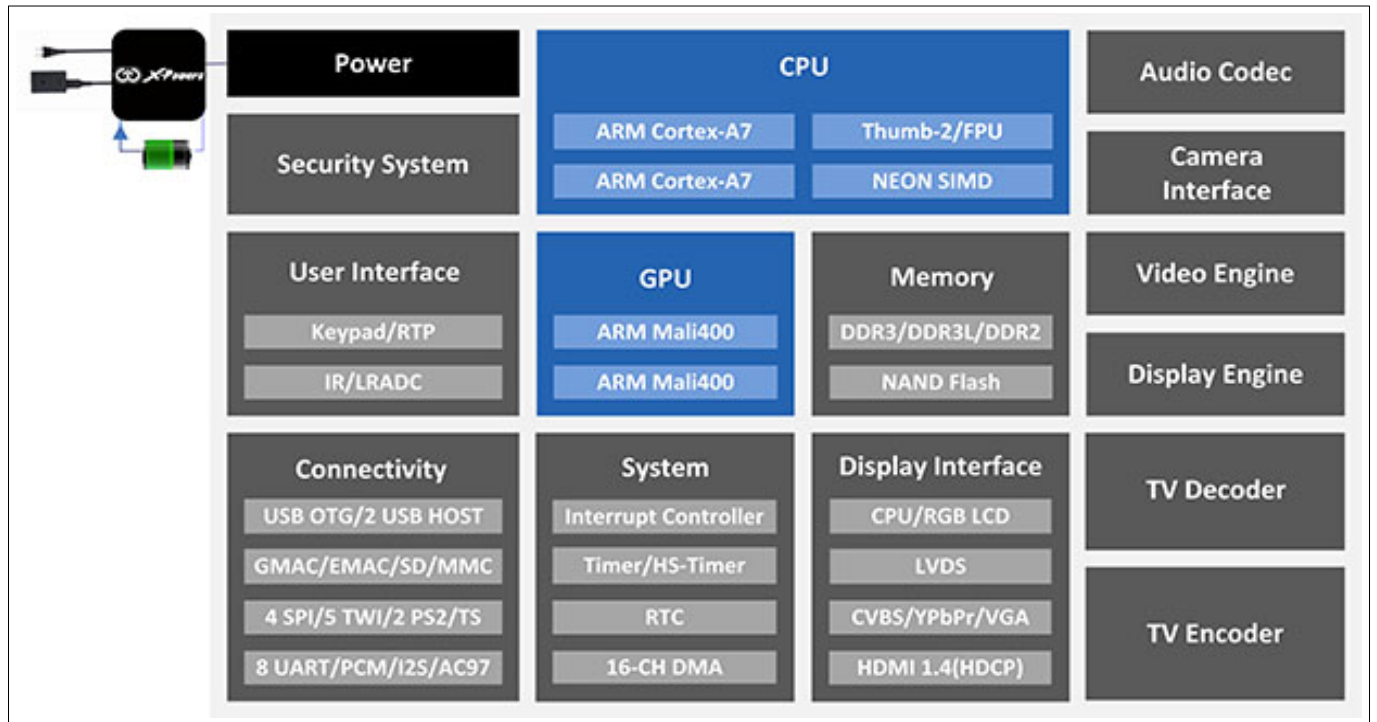

CHAPTER 5: CONTROL CIRCUITY

5. Introduction to the chapter

Here you can find information about reset circuit and quartz crystals locations, the power supply circuit is also briefly discussed.

5.1 Reset

The board has hardware reset controlled by the AXP209 power system management IC.

It is a good practice to perform software reset of the board. Performing reset by disconnecting the power supply might lead to software corruption of the operating system of choice.

5.2 Clocks

25 MHz quartz crystal Q1 is connected to pins X1 and X2 of the RTL8211CL Gigabit Ethernet controller.

32 768 Hz (RTC) quartz crystal Q4 is found at pins F1 and F2 of the A20 microcontroller.

24 MHz quartz crystal Q3 is found at pins N22 and N23 of the A20 microcontroller.

5.3 Power supply circuit

The power supply is handled mainly by AXP209 power management system, an Allwinner chip that goes together with the A20 processor. It is mounted on the board but since it is relatively hard to find we also sell it separately.

The power supply circuit of A20-OLinuXino-LIME2 requires input supply of 5V. The minimum wattage is 2.5W, and this threshold may raise if using a lot of devices on the USB-HOST (via external hub), a lot of GPIOs or you have a display connected to the LCD_CON or a hard disk powered from the 5V_SATA_PWR connector. If a discharged Li-Po battery is connected to the respective connector the power consumption of the whole LIME2 board might rise enormously, since the built-in battery charger would attempt to recharge it.

For more info on how to power the board refer to chapter “2.3 Powering the board”.

CHAPTER 6: CONNECTORS AND PINOUT

6. Introduction to the chapter

In this chapter are presented the connectors that can be found on the board all together with their pinout and notes about them. Jumpers functions are described. Notes and info on specific peripherals are presented. Notes regarding the interfaces are given.

6.1 UART0 interface

The UART0 interface might be used for serial communication between the board and a personal computer by default. In case of video output problem a cable might provide needed feedback and greatly reduce the efforts needed to repair the board or to adjust the software setting.

Note that by default only UART0 is defined as a port suitable for serial debug. You can use our USB-SERIAL-CABLE-F for debugging.

Consider table below when connecting the USB-SERIAL-CABLE-F according to the wire color code. The RX line of the cable (GREEN wire) should go to TX line of the target board; the TX line of the cable (RED wire) should go to the RX line of the target board. The BLUE wire should go to the target's GND line.

UART0		
Pin #	Signal name	Processor pin
1	UART0-TX	A7
2	UART0-RX	B7
3	GND	-POWER CIRCUIT-

6.2 MicroSD card connector

The micro SD card slot is primarily used for booting the operating system.

The board works with micro SDHC cards up to 32GB of storage.

As a general precaution be careful with the SD cards you purchase. There is a big percentage of fake cards due to the low effort required to counterfeit popular brands and the big demand for SD cards worldwide. When in doubt – try the same operation with another card from another brand.

Olimex sells microSD cards with Linux or Android images, that have been tested – please refer to chapter “2.2 Requirements”. Of course, if you already have a large enough microSD card you can download the official Linux image from the wiki pages: <https://www.olimex.com/wiki/A20-OLinuXino-LIME2>.

When removing the card, please make sure that you release it from the connector by pushing and NOT by pulling the card directly (this can damage both the connector and the microSD card).

6.2.1 SD/MMC1 slot

The schematic related to the SD/MMC (microSD connector) is located on the top of the board and the schematic shown below:

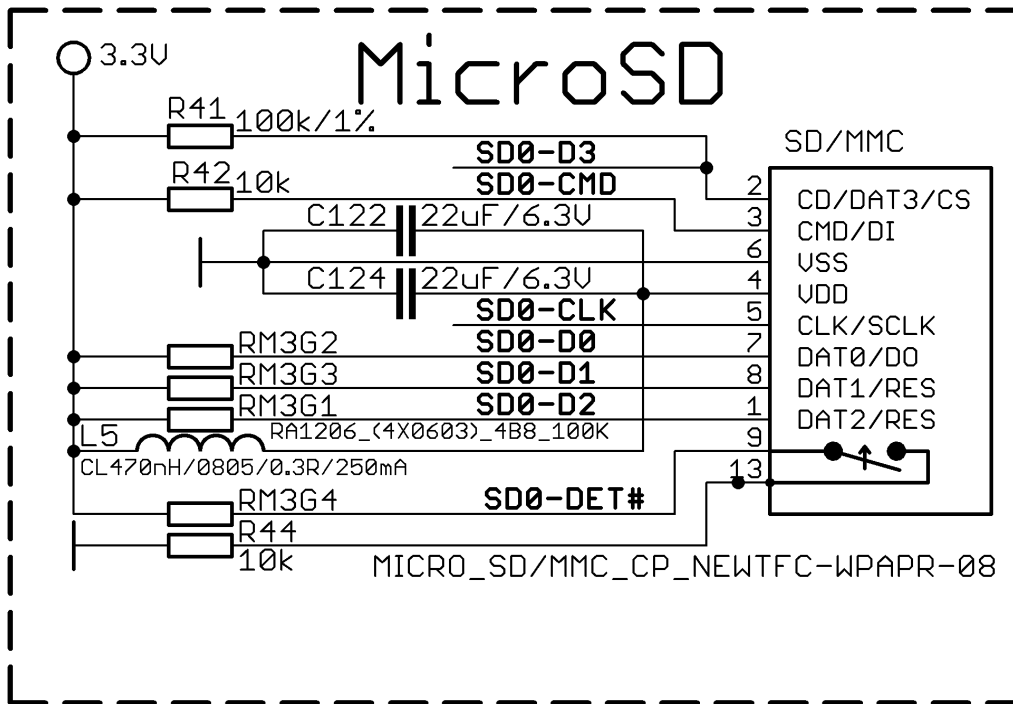

This slot is typically used for booting the OS, due to the larger capacities of the microSD cards (compared to SD or MMC cards). It is suggested to have an SD card with a proper Linux/Android image especially if you have ordered a version of the board without NAND memory. It is also recommended to use Class 10 (10MByte/sec) card for faster read/write operations, lower class cards (especially higher capacity ones) might slow down the whole system.

SD/MMC connector		
Pin #	Connector signal name	Wire name (processor pin)
1	DAT2/RES	SD0-D2 (K19)
2	CD/DAT3/CS	SD0-D3 (K20)
3	CMD/DI	SD0-CMD (L19)
4	VDD	-POWER CIRCUIT-
5	CLK/SCLK	SD0-CLK(L20)
6	VSS2	-POWER CIRCUIT-
7	DAT0/DO	SD0-D0(M19)
8	DAT1/RES	SD0-D1(M20)

Additionally, there are the WP and CP switches that are responsible, respectively, for sensing whether the card is locked for reading and whether there is a card inserted.

6.3 PWR jack

The power jack used is the typical DC barrel jack one used by Olimex (2.1×6.3×9.2mm) in most of our products. More information about the exact component might be found here:

<https://www.olimex.com/wiki/PWRJACK>

You should provide 5 volts direct current and the required current may vary depending on the peripherals connected to the board. The power supply you use should be capable of providing at least 1A of current.

Pin #	Signal name
1	Power input
2	GND

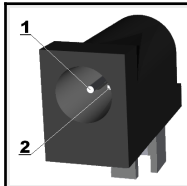

More info about the power supply can be found in chapter 5 of this manual.

6.4 USB_OTG

The main way of changing the firmware image located on the NAND of A20-OLinuXino-LIME2-4GB is via the USB-OTG connector – the update of the Android image is explained at the bottom of this sub-chapter. The connector can also be used for establishing SSH connection to the default Debian Linux of LIME2 boards (for more information about the tethering please refer to “2.5.4 SSH via mini USB cable in Debian”). The part of the schematic related to the USB_OTG is shown below:

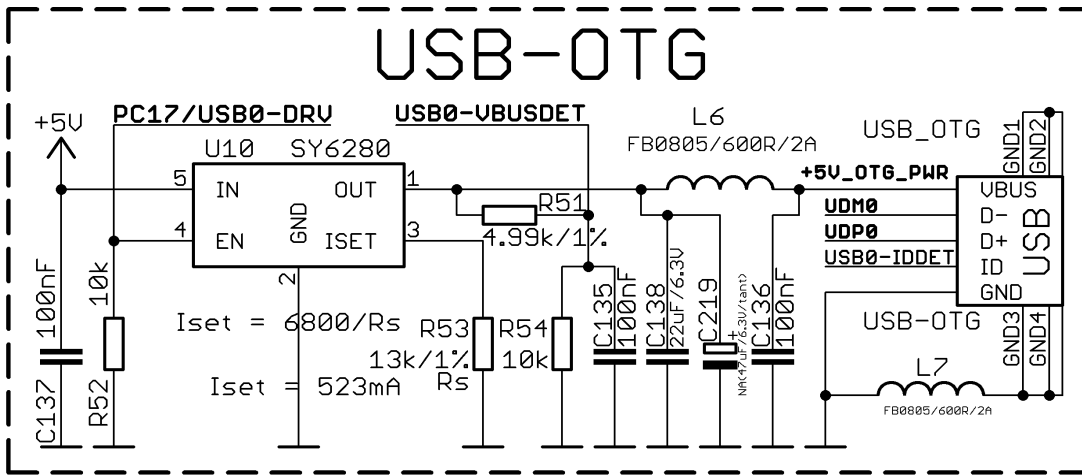

USB_OTG connector		
Pin #	Signal name	Processor pin
1	+5V_OTG_PWR	-POWER CIRCUIT-
2	UDM0	N20
3	UDP0	N21
4	USB0-IDDET	B5
5	GND	-POWER CIRCUIT-

The USB_OTG features Low Loss Power Distribution Switch SY6280 which protects the board in case the devices you have plugged to the USB_OTG attempt to draw more current than 523mA combined. The maximum current available on the 5V USB_OTG is exactly 523mA. The SY6280 responsible for the USB_OTG is enabled by USB0-DRV (processor pin C12, port B9), thus the USB_OTG is also controlled by the same signal.

Please note that the USB0-DRV (PC17, processor pin F23) also goes to the AXP209!

The connector case is also grounded.

We have configured an Android image with settings suitable for A20-OLinuXino-LIME2. You can upload it to the board with PhoenixSuit software via the USB-OTG. The image is available for users to try and tweak the settings. The images can be downloaded from the wiki article at: <https://www.olimex.com/wiki/A20-OLinuXino-LIME2>.

The board variant without NAND needs an SD card with bootable OS – Android or Linux. There are ready images available for download at the above-linked A20 wiki article.

To repair the image on NAND re-upload it following these easy steps:

1. Install and run PhoenixSuit (can be found in the wiki article of the board).
2. Go to firmware tab of the program and point to a valid Android image (the latest official one may also be downloaded from the wiki article).
3. Disconnect the power supply and USB cable from the A20 board.
4. Press and hold RECOVERY button, apply power supply 5V, release RECOVERY button.

5. Connect USB cable to the mini USB connector
6. You will be asked for drivers for the bootloader. Navigate to the folder where you extracted the PhoenixSuit and install the drivers from the respective executables (or manually point the installer to the drivers folder in the PhoenixSuit installation path).
7. PhoenixSuit will detect the board and would ask for the method of writing the image. Choose method of writing the image and confirm your wish to write the image.
8. Wait till upgrade succeeds.

6.5 USB_HOST connectors

The part of the schematic related to the USB_HOST connectors is listed below:

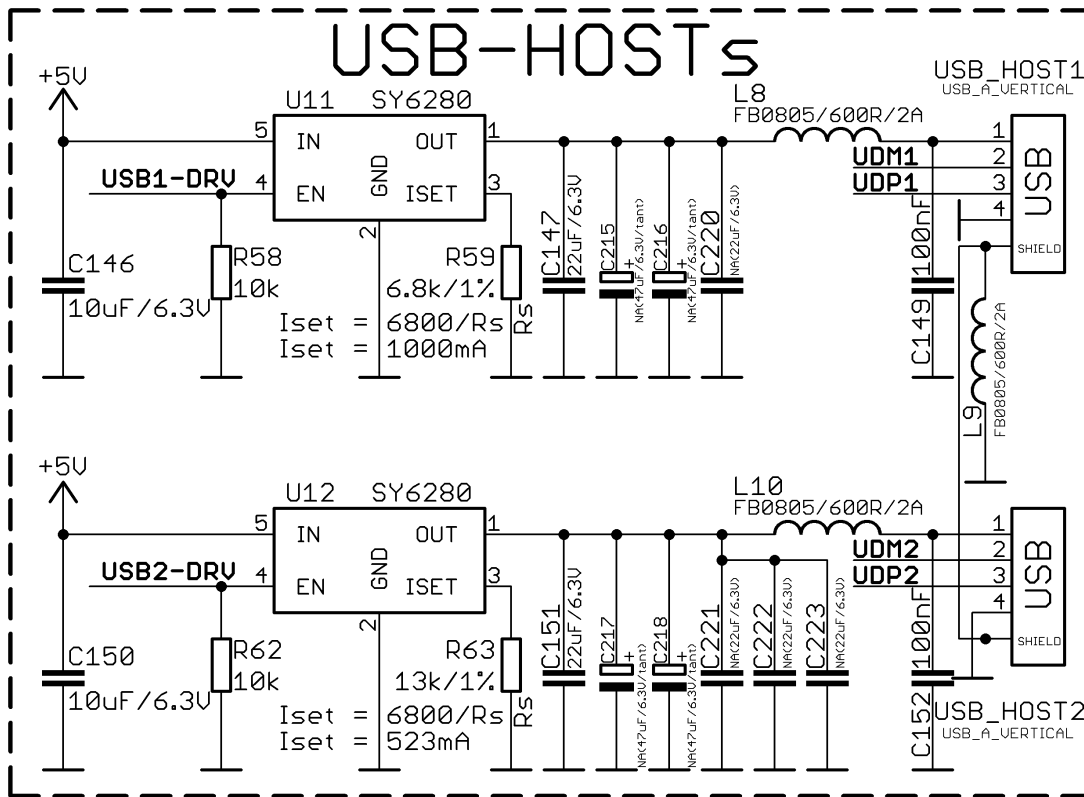

There are two USB host connector featured on the board. They are called USB_HOST1 and USB_HOST2. Each of them has own connector, both situated near the Ethernet connector. Each of connector has own low loss power distribution switch SY6280 which protects the board in case the devices you have plugged to the board try to draw more current than 523mA combined. The maximum current available on each of the USB hosts is exactly 523mA.

The SY6280 responsible for the USB_HOST1 is enabled by USB0-DRV1 (processor pin A4).

The SY6280 responsible for the USB_HOST2 is enabled by USB0-DRV2 (processor pin A5).

USB_HOST connectors					
USB_HOST1	Signal name	Processor pin	USB_HOST2	Signal name	Processor pin
Pin #1	5V	Connected to SY628	Pin #1	5V	Connected to SY628
Pin #2	UDM1	P20	Pin #2	UDM2	R20
Pin #3	UDP1	P21	Pin #3	UDP2	R21
Pin #4	GND	-POWER CIRCUIT-	Pin #4	GND	-POWER CIRCUIT-

The GND is common for both levels of the USB_HOST.

6.6 Gigabit Ethernet

The LAN connectivity is handled by Realtek's RTL8211E (RTL8211CL in hardware revisions prior to revision G). It is capable of transmission rate up to 1Gbps over industry standard CAT.5 UTP cable with BER less than 10⁻¹⁰ in 1000Base-T. The controller is compatible with some of the major industry standards. It complies with 1000Base-T IEEE 802.3ab; 100Base-TX IEEE 802.3u; 10Base-T IEEE 802.3; and IEEE 802.3 RGMII; among others.

The Ethernet connector is grounded according to the standard (check GND1 and GND2 lines on the schematics).

If you use Linux then the Ethernet connector might be used for SSH connection to the board. If you lack any other option for debugging it might be hard to guess the correct IP of the board since it has DHCP enabled by default (especially if you are in a large network). It is good idea to check the default settings by exploring the Linux image settings. Those are usually stored in:

```
/etc/network/interfaces
```

For DHCP you need to enable auto detection and dhcp as shown below:

```
auto eth0
iface eth0 inet dhcp
```

For setting a static address please follow the pattern below:

```
auto eth0
iface eth0 inet static
address 192.168.1.5
netmask 255.255.255.0
gateway 192.168.1.254
```

The EEPROM memory may be used to store the MAC address.

Important: In some Debian images it is possible that the Ethernet doesn't get auto-detected during boot-up. This is done on purpose because if there is auto-detection enabled and you don't want to use the Ethernet connector or you have forgotten to plug a cable the start-up would be greatly delayed. This might be problem in the first start-up to users counting only on SSH connection. You can enable the Ethernet after a successful boot-up with:

```
ifconfig -a
dhclient eth#(as seen after after the ifconfig command)
```

Important: You can configure static/DHCP-given IP addresses in /etc/network/interfaces

LED		
LED	Color	Usage
Bi-color LED1	Orange/Green	Speed status/Link status
Single color LED2	Yellow	Activity status

*The speed status of LED1 (typically indicated by the orange color of the bi-color LED1) is not available. Only the link status indicated by the green LED is available currently.

6.7 HDMI connector

The part of the schematic that describes the HDMI module is shown below:

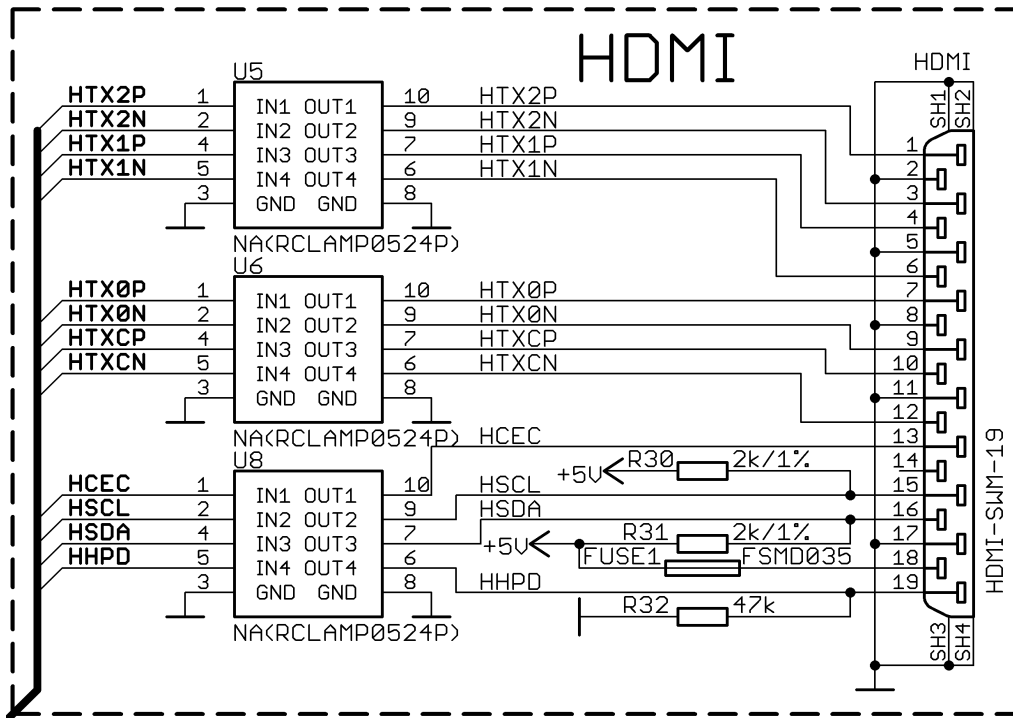

Note that there are different Linux images depending whether the HDMI TV works at 50Hz or 60Hz refresh rate. If you board runs Android there is a specific option to set the appropriate HDMI output.

HDMI connector					
Pin #	Signal name	Processor pin	Pin #	Signal name	Processor pin
1	HTX2P	T23	11	GND	-POWER CIRCUIT-
2	GND	-POWER CIRCUIT-	12	HTXCN	W22
3	HTX2N	T22	13	HCEC	P23
4	HTX1P	U23	14	NA*	NA
5	GND	-POWER CIRCUIT-	15	HSCL	R23
6	HTX1N	U22	16	HSDA	R22
7	HTX0P	U23	17	GND	-POWER CIRCUIT-
8	GND	-POWER CIRCUIT-	18	+5V	-POWER CIRCUIT-
9	HTX0N	U22	19	HHPD	P22
10	HTXCP	W23			

*Pin 14 of the HDMI is not mandatory. In HDMI 1.0-1.3c it is reserved pin; in HDMI 1.4+ it is optional.

6.8 SATA connector and power

The part of the schematic describing the SATA module is shown below:

SATA connector		
Pin #	Signal name	Processor pin
1	GND	-POWER CIRCUIT-
2	SATA-TXP	T20
3	SATA-TXM	T21
4	GND	-POWER CIRCUIT-
5	SATA-RXM	U21
6	SATA-RXP	U20
7	GND	-POWER CIRCUIT-

The SATA connector allows you to connect hard drives to the board. There is support for SATA drives in the official images. The connector is suitable for both regular hard drives and SSD ones.

Note that you can power only 5V hard drives via the board's 5V_SATA_PWR connector. If your hard drive requires 12V of voltage you would need to provide external power supply.

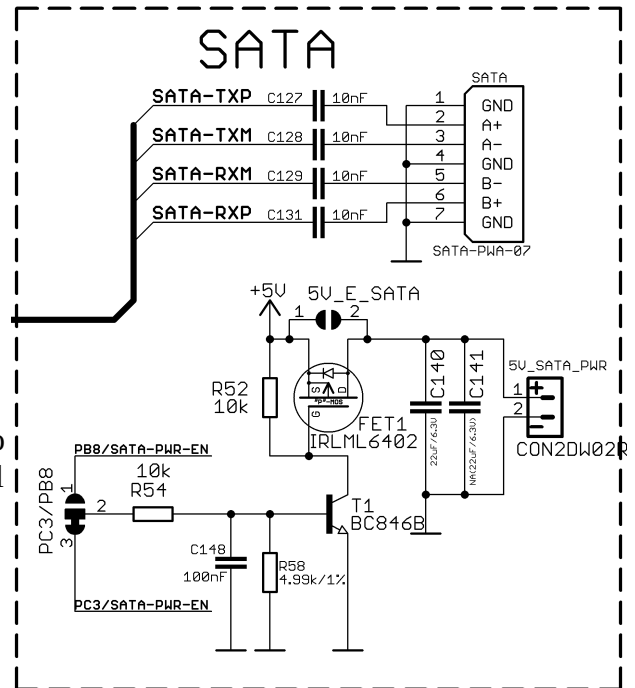

To keep the low form factor we have placed the small JST connector.

You can make an adapter cable accordingly. The other options is to check the SATA-CABLE-SET that we have available.

For more information please visit: <https://www.olimex.com/Products/Components/Cables/SATA-CABLE-SET/>

Pay note the two jumpers 5V_E_SATA and PC3/PB8 located at the bottom of the board (under the HDMI connector). The first one 5V_E_SATA is open by default because the board has software control of the powering for the hard disk. If you close 5V_E_SATA there would always be 5V at the 5V_SATA_PWR connector.

Which pin does the software control of the SATA powering is determined by the position of the PC3/PB8 jumper. By default PC3 is used.

6.9 GPIO connectors

There are four GPIO ports which are used generally to access unused by the board's peripherals pins. However, there are exceptions – some of the pins might be used to easily peripherals or their levels.

Three of the GPIO connectors have 40 pins and the last one has 20 pins. Note that all GPIO connectors have 0.05" (50 mil) step between pins. Olimex sells a compatible extension cable for these connectors named CABLE-40-40-10CM.

IMPORTANT: the cables and the 0.05" connectors are very fragile – if you attempt to disconnect the setup by pulling the cable it might break! Furthermore – you might bend the board's or the cable's pins! Use pliers or other suitable object to disconnect the connectors carefully!

Important: each pair of rows of pins of all GPIO connectors on A20-OlinuXino-LIME2 are swapped compared to A20-OLinuXino-LIME and A10-OLinuXino-LIME!

Important: 3.3V and +5V from the GPIO connectors are only outputs. You should never use them to power the board.

Most of the pins are already defined in default operating system images. Some of them can be used as GPIOs, I2C or SPI without much of a problem. Information on the software usage of GPIO ports might be found in chapters “2.8 GPIO under Debian” and “2.9 I2C and SPI under Debian”

6.9.1 GPIO-1 (General Purpose Input/Output) 40pin connector

This connector features the processor signals needed for audio headphones output and microphone input. Please note that not only the connectors but also the rest of the schematic is missing! You would need to add resistors and capacitors. The connector also has the signals needed for a VGA output. The official Linux Debian images include a script that can be used to change the video output to VGA. We don't provide Android images for the VGA video output.

Microphone signals are: MICIN1 and VMIC

Headphone signals are: HPOUTL, HPCOM and HPOUTR

Please note that part of the VGA and composite video signals are multiplexed (VGA-R, VGA-B, VGA-G share the same pins with the TVOUT signals).

Composite video signals are located on GPIO-1 connector: TVOUT0 (GPIO-1 pin 20), TVOUT1 (GPIO-1 pin 22), TVOUT2 (GPIO-1 pin 24); you would also need AGND (GPIO-1 pin 4)

VGA signals are located at GPIO-1 connector and LCD_CON connector: The total of 5 signals you need for VGA output can be split into two categories:

- 1) Data signals: VGA-R (AC17); VGA-B (AB16); VGA-G (AC16)
- 2) Synchronization signals: LCD_VSYNC (AC9) and LCD_HSYNC (AB9)

If you inspect the schematics of a board with VGA connector (like A20-OlinuXino-MICRO or A20-SOM-EVB) carefully you would notice that there are two extra transistors on the synchronization lines. Those are transistors meant to shift the levels to 5V. The 3.3V levels from the processor might work but the standard requires 5V levels of VSYNC and HSYNC. However, if you lead the signals to a 6 pin header (like the one on the A20 board) you might use the cable for the A20-OlinuXino-MICRO (called A20-VGA-CABLE). The 6 signals needed are the 5 signals mentioned about plus GND.

A general advice for easier use of the microphone, headphone and VGA interfaces of A20-OLinuXino-LIME2 is to take a look at the schematics of another board with those interfaces already installed. For example, those are present in A20-OLinuXino-MICRO. Inspect the schematic carefully.

The signal layout is described on the next page:

GPIO-1 connector					
Pin #	Signal name	Processor pin	Pin #	Signal name	Processor pin
1	+5V	-POWER CIRCUIT-	2	GND	-POWER CIRCUIT-
3	3.3V	-POWER CIRCUIT-	4	AGND	-POWER CIRCUIT-
5	PG0	F20	6	LRADC0	AB23
7	PG1	E21	8	LRADC1	AB22
9	PG2	E20	10	MICIN1	AC20
11	PG3	D21	12	VMIC	AA21
13	PG4	D20	14	HPOUTL	Y19
15	PG5	C21	16	HPCOM	AA19; AA20
17	PG6	E19	18	HPOUTR	W19
19	PG7	C20	20	VGA-G	AC16
21	PG8	D19	22	VGA-B	AB16
23	PG9	C19	24	VGA-R	AC17
25	PG10	D18	26	UART0-RX	B7*
27	PG11	C18	28	UART0-TX	A7*
29	PC3/SATA-PWR-EN	L22**	30	PB21	C7
31	PC18	F22	32	PB20	C8
33	PC19	L21	34	PB19	B8
35	PC20	K21	36	PB18	A8
37	PC21	J21	38	PC24	F21
39	PC22	J20	40	PC23	G19

*Signals marked with * are multiplexed with either a peripheral device or another connector. Ensure that the multiplexing is handled properly on software and/or hardware level (else there would probably occur wrong levels, loss of data, etc).

**Pin #29 is used to control the power supply available at the 5V_SATA_PWR by default

6.9.2 GPIO-2 (General Purpose Input/Output) 40pin connector

The GPIO pins are led out on a separate 40pin connector. They allow the user to attach additional hardware, check readings or perform hardware debug. The GPIO-2 connector numbers are printed at the bottom of the board for your convenience.

GPIO-2 connector					
Pin #	Signal name	Processor pin#	Pin #	Signal name	Processor pin#
1	+5V	-POWER CIRCUIT-	2	GND	-POWER CIRCUIT-
3	3.3V	-POWER CIRCUIT-	4	LD03_2.8V	Goes to AXP209
5	TWI0-SCK	A15	6	PE0	E23
7	TWI0-SDA	B15	8	PE1	E22
9	PI0	A20	10	PE2	D23
11	PI1	B20	12	PE3	D22
13	PI2	A19	14	PE4	C23
15	PI3	B19	16	PE5	C22
17	PI4	A18	18	PE6	B23
19	PI5	B18	20	PE7	B22
21	PI6	A17	22	PE8	A23
23	PI7	B17	24	PE9	A22
25	PI8	A16	26	PE10	B21
27	PI9	B16	28	PE11	A21
29	PI10	A15	30	PI21	E13
31	PI11	B15	32	PI20	E14
33	PI12	A14	34	PI19	D14
35	PI13	B14	36	PI18	E15
37	PI14	A13	38	PI17	E16
39	PI15	B13	40	PI16	E17

Signals marked with * are multiplexed with either a peripheral device or another connector. Ensure that the multiplexing is handled properly on software and/or hardware level (else there would probably occur wrong levels, loss of data, etc).

6.9.3 GPIO-3 (General Purpose Input/Output) 40pin connector

GPIO-3 connector					
Pin #	Signal name	Processor pin#	Pin #	Signal name	Processor pin#
1	+5V	-POWER CIRCUIT-	2	GND	-POWER CIRCUIT-
3	3.3V	-POWER CIRCUIT-	4	PB3	B14
5	RESET_N	C14	6	PB4	A13
7	PH0	C6	8	PB5	B13
9	PH7	B4	10	PB6	A12
11	PH9	D4	12	PB7	B12
13	PH10	A3	14	PB8/SATA-PWR-EN	A11
15	PH11	B3	16	PB9	C12
17	PH12	C3	18	PB10	C11
19	PH13	A2	20	PB11	C10
21	PH14	B2	22	PB12	C9
23	PH15	A1	24	PB13	B11
25	PH16	B1	26	PB14	A10
27	PH17	C1	28	PB15	B10
29	PH18	C2	30	PB16	A9
31	PH19	D1	32	PB17	B9
33	PH20	D2	34	PH24	E3
35	PH21	D3	36	PH25	E4
37	PH22	E1	38	PH26	F3
39	PH23	E2	40	PH27	F4

6.9.4 GPIO-4 (General Purpose Input/Output) 20pin connector

GPIO-4 connector features the rest of the signals available and few additional signals that might need testing.

GPIO-4 connector					
Pin #	Signal name	Processor pin#	Pin #	Signal name	Processor pin#
1	3.3V	-POWER CIRCUIT-	2	GND	-POWER CIRCUIT-
3	TVOUT3	AB17	4	NMI_N	F5
5	TVIN0	AC18	6	MIC1OUTP	AC22
7	TVIN1	AB18	8	MIC1OUTN	AC23
9	TVIN2	AA17	10	MICIN2	AC21
11	TVIN3	Y17	12	PA9	E9
13	LINEINR	AB21	14	PA14	D12
15	LINEINL	AB20	16	PC7	J22
17	FMINR	Y21	18	PC16/NWP	M21*
19	FMINL	Y20	20	PC17/USB0-DRV	F23

Signals marked with * are multiplexed with either a peripheral device or another connector. Ensure that the multiplexing is handled properly on software and/or hardware level (else there would probably occur wrong levels, loss of data, etc).

6.10 LCD_CON 40pin connector

The LCD_CON pins are led out on a separate 40pin connector for the ease of connecting an LCD. We have tested the ability of the board to interact with such a display. They allow the user to attach additional hardware, check readings or perform hardware debug.

The LCD connector is suitable for a number of Olimex displays and touchscreen panels with different native resolution – the smallest available is the **4.3"** one called **LCD-OLinuXino-4.3TS** with native screen resolution of **480×272**, through the **7"** one named **LCD-OLinuXino-7TS** with **800×480**, to the **1024×600 10.1" LCD-OLinuXino-10TS**. Typically, you need a single cable for the connection between the board and the display.

Important: if you have an old display (A13-LCDx-xx) you need additional adapter board and two different 40PIN ribbon cables to connect an Olimex display and the LCD_CON.

Important: the two rows of pins of LCD_CON connector on A20-OlinuXino-LIME2 are swapped compared to A20-OLinuXino-LIME and A10-OLinuXino-LIME!

Please note that the smallest display (4.3", 480×272) is not suitable for the official Android images we provide.

LCD_CON connector					
Pin #	Signal name	Processor pin	Pin #	Signal name	Processor pin
1	+5V	-POWER CIRCUIT-	2	GND	-POWER CIRCUIT-
3	+3.3V	-POWER CIRCUIT-	4	GND	-POWER CIRCUIT-
5	LCD_D16	Y12	6	LCD_D17	AA12
7	LCD_D18	Y11	8	LCD_D19	AA11
9	LCD_D20	Y10	10	LCD_D21	AA20
11	LCD_D22	AB12	12	LCD_D23	AC10
13	LCD_D8	AB11	14	LCD_D9	AC11
15	LCD_D10	Y15	16	LCD_D11	AA15
17	LCD_D12	Y14	18	LCD_D13	AA14
19	LCD_D14	Y13	20	LCD_D15	AA13
21	LCD_D0	AB15	22	LCD_D1	AC15
23	LCD_D2	AB14	24	LCD_D3	AC14
25	LCD_D4	AB13	26	LCD_D5	AC13
27	LCD_D6	AB12	28	LCD_D7	AC12
29	LCD_HSYNC	AB9	30	LCD_VSYNC	AC9
31	LCD_CLK	Y9	32	LCD_DE	AA9
33	PB3	B14	34	PB4	A13
35	LCD_PWR	C4	36	PB2/PWM0	A14*
37	TPX1	Y22	38	TPX2	AA22
39	TPY1	Y23	40	TPY2	AA23

Signals marked with * are multiplexed with either a peripheral device or another connector. Ensure that the multiplexing is handled properly on software and/or hardware level (else there would probably occur wrong levels, loss of data, etc).

Full list of recommended displays for the board might be found in chapter “2.7 Connecting and calibrating a display”.

IMPORTANT:

You need to upload new Android image to the board. These images are available here: <https://www.olimex.com/wiki/A20-OLinuXino-LIME2> (using an operating system – NAND flash).

In Debian Linux you would need to start a shell script to change the built-in the image resolution settings. Start it with `./change_display_a20_olimex.sh` and follow the instructions. Please refer to chapter 2.6 “Changing the default image resolution” for more information.

6.11 Jumper description

Please note that most the jumpers on the board are SMT type. If you feel insecure of your soldering/cutting technique it is better not to try to adjust the jumpers since it is possible to damage the board.

Board jumpers			
Jumper name	Type	Default position	Function
NAND_E	SMT	Either CLOSED or OPEN, depending whether the board has 4GB NAND MEMORY MODULE	Controls whether the NAND memory module is enabled or disabled. If the jumper is closed than the NAND memory is operational.
PC3/PB8	SMT	PC3	Controls which processor pin should be used for SATA power enabling signal. By default the SATA powering control uses processor pin L22 which is port PC3. Changing this jumper also changes the availability of PC3 and PB8 at GPIO-1 pin 29 and GPIO-3 pin 16. Please note that if you change the position of the jumper from PC3 to PB8 then you might block one of the processor pins responsible for I2S and AC97 audio output.
PB9/PH7_USB	SMT	PB9	Controls which processor pin should be used for the USB_OTG. By default the USB_OTG uses processor pin C12 which is port PB9. The same pin/port is used for I2S audio. In case you want to access the I2S capabilities of the board you would need to change the default position.
PB9/PH7_GPIO	SMT	PH7_GPIO	PB9/PH7_GPIO jumper controls which of the two ports (PB9 or PH7) should be lead out to pin 9 of GPIO3 connector for easier access. Changing this jumper also changes the signal available at GPIO-3 connector's pin 9. By default this jumper is in PH7_GPIO position and PH7 is lead to pin 9 of GPIO3.

6.12 Additional hardware components

The components below are mounted on OLinuXino but are not discussed above. They are listed here for completeness:

Reset button – used to reset the board

Power button – used to reset the board

Recovery button – used to reset the board

1GB = 2×[4Gb(256M x 16b)] DDR3 SDRAM – the exact memory used currently in the board is SAMSUNG K4B4G1646D-BCK0

In the latest Debian images the DDR3 RAM memory is set at 384MHz, which is the most conservative and stable clock for the A20 designs. This is the recommended clock for boards in heavy duty designs.

The lower the RAM clock – the greater the stability. We recommend performing stability tests in a real environment and decide what value is the most stable in your specific case. The value that we use in our default images is 384 just in case somebody uses the board in environments with higher than typical ambient temperature or in applications that stress the memories all the time.

If you wish to change the clock of the RAM memory you need to rebuild the u-boot as per our instructions and either set higher clock speed in the MENUCONFIG or directly change the value of the “CONFIG_DRAM_CLK” in the defconfig file for the board.

The DDR3 memory part name in the schematic might be outdated. We have used a number of different but fully compatible DDR3 memories due to supply unavailability. It is always recommended to check the exact memory name printed on the component itself.

4GB =1×[32Gb(4096M x 8b)] NAND FLASH – only available on the 4GB version of the board; the exact memory used in the board revision mentioned is HYNIX H27UBG8T2BTR

PWR_LED – turns on upon powering the board

CHGLED – lights when charging a battery connected to the Li-Po battery connector.

CHAPTER 7: SCHEMATICS

7. Introduction to the chapter

In this chapter is located information about the schematics describing logically and physically A20-OLinuXino-LIME2.

7.1 Eagle schematic

OLinuXino schematics may be found it on the OLinuXino's GitHub repository: <https://github.com/OLIMEX/OLINUXINO/tree/master/HARDWARE>. You can download the whole repository as .zip without having a GitHub account.

We mostly use Eagle by Cad Soft 4.16r2 for designing. However, the files should be compatible with the latest Eagle available. Cad Soft offers a trial version of their software that allows you to inspect schematics and board files (without being able to modify them).

This work is licensed under the Creative Commons Attribution-ShareAlike 3.0 Unported License. To view a copy of this license, visit <http://creativecommons.org/licenses/by-sa/3.0/>.

If you are looking for a schematic of an older revision of the board and it isn't available at our web site you may request it by the support e-mail.

7.2 Physical dimensions

Note that all dimensions are in mils.

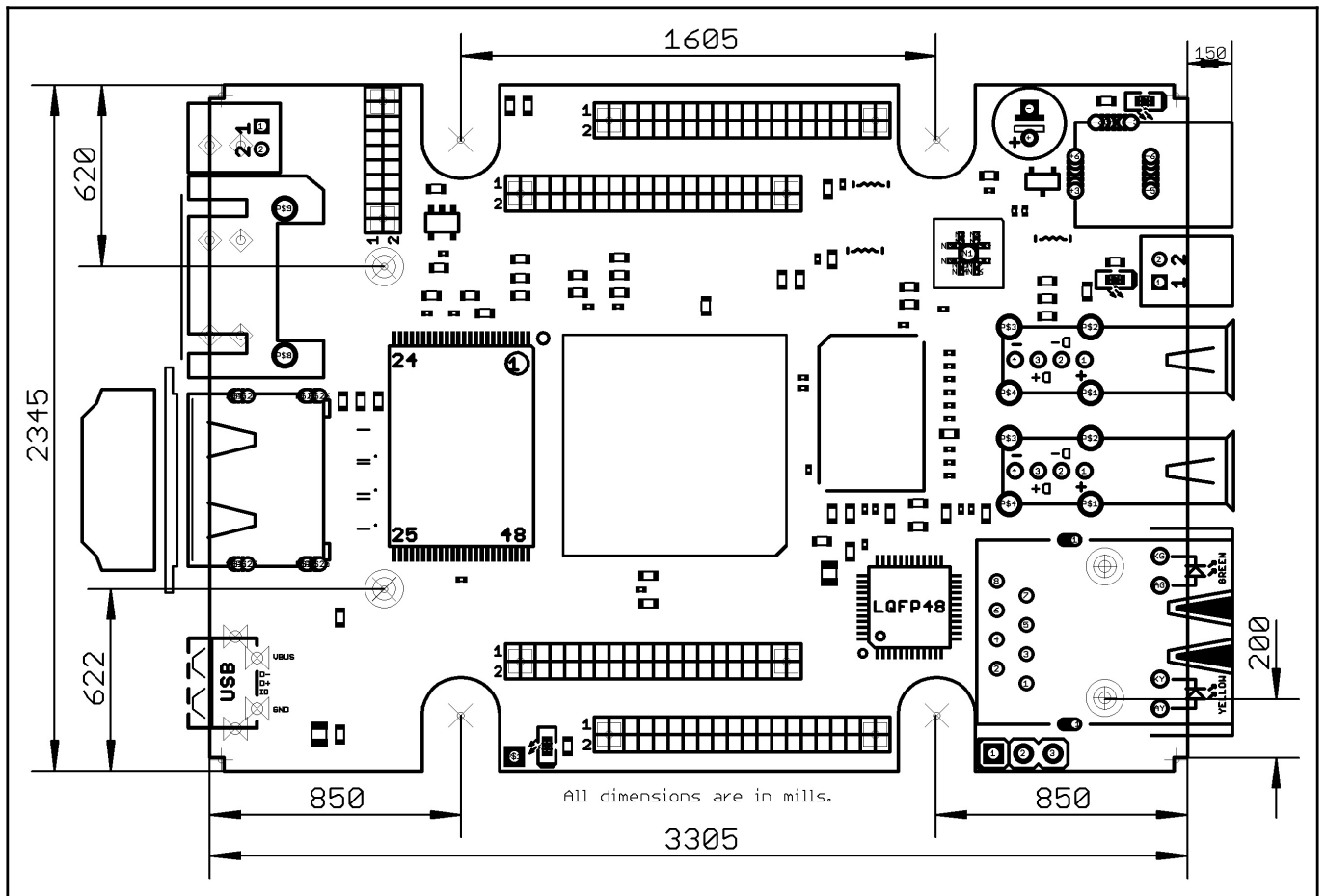

CHAPTER 8: REVISION HISTORY AND SUPPORT

8. Introduction to the chapter

In this chapter you will find the current and the previous version of the document you are reading. Also the web-page for your device is listed. Be sure to check it after a purchase for the latest available updates and examples.

8.1 Document revision

Document revision	Changes	Modified pages
A, 27.02.15	Initial manual release	All
B, 17.03.15	Updated HDMI part according to the latest schematic;	31
	Updated DDR3 memory according to the latest schematic;	40
C, 30.11.15	Made it more obvious that there are differences in the layout of LIME2 and LIME connector board layout;	33, 37;
	Clarified that the 4GB version of the board is now sold without Android;	5, 6;
	Updated hardware board revision changes	43
D, 23.12.15	Clarified that we no longer load Android on the 4GB version of the board; Added information about Debian nandinstall	All
E, 27.10.16	Added info that default memory clock of 384Mhz in the latest official images	40
F, 07.02.17	Fixed wrong pinout in GPIO-3 table	36
G, 08.09.17	Fixed a number of typos; added information about the new hardware revision; added information about different variants of the board	All
H, 20.05.22	Fixed and deleted big chunks of outdated information but the document still needs major overhaul	All

8.2 Board revision

Remember to check the schematics and the board design files to compare the differences.

Board revision	Notable changes
C (released)	Initial release of the board
D (not released)	<ol style="list-style-type: none"> 1. Added eMMC option (can be used instead of NAND). By default everything is set to NAND; 2. Added C224 and C232 (47uF/6.3V/0805) in parallel to the 5V_SATA_PWR connector; 3. Changed L1, L2, L3 from FB/600R/0805 to 0R/0805 – the power supply seems more stable with the new values; 4. Capacitors C84, C85 changed from 100nF/0402 to 22uF/0603; 5. Fixed the white print at the bottom of the board, now it properly says “A20-OLinuXino-LIME2”; 6. Completely re-routed the Ethernet and the EEPROM in order to reduce noise;
E (not released)	<ol style="list-style-type: none"> 1. Small improvements in routing, libraries and cream layer; 2. The 3-pin SMD jumper EMMC_PWR now gets a white print for the different positions; 3. Board's revision name was changed to Rev_E. 4. U15 and U17 were changed from SY8008C(AA)C to SY8009AAAC(SOT23-5).
F (not released)	<ol style="list-style-type: none"> 1. PHY changed to RTL8211E-VB-CG1 2. Rx pullups moved before the serial matrix for better routing.
G (released)	<ol style="list-style-type: none"> 1. Added four mount holes 3.3mm like on A20-olinuxino-Micro, connected to GND, odd milling shape changed to rectangular. 2. R109 change from 47k/0402 to 470k/0402, R107 changed from 470k/0402 to capacitor 220nF/0402, because new PHY consumes too much current at startup.

8.3 Useful web links and purchase codes

The web page you can visit for more information about your device are:

*Product page: <https://www.olimex.com/Products/OLinuXino/A20/A20-OLinuXino-LIME2/>

*Wiki article of the board: <https://www.olimex.com/wiki/A20-OLinuXino-LIME2>

*A place for general questions, FAQ or friendly talk: <https://www.olimex.com/forum/>.

*You can get the latest updates on the software at: <https://github.com/OLIMEX/OLINUXINO>.

*You may may join our IRC channel #olimex @ freenode.net (<http://webchat.freenode.net/?channels=olimex>).

*The sunxi community is behind the Allwinner Linux support: http://linux-sunxi.org/Main_Page.

ORDER CODES:

A20-OLinuXino-LIME2 – base version of the board, with no extra flash

A20-OLinuXino-LIME2-e4GB – the product for which this manual is about

A20-OLinuXino-LIME2-n4GB – the product for which this manual is about

A20-OLinuXino-LIME2-n8GB – the product for which this manual is about

USB-SERIAL-CABLE-F – USB serial console cable female

USB-MINI-CABLE – standard USB type A to USB type mini cable

SY0605E – reliable power supply adapter 50Hz (EU) 5V/1A for A20-OLinuXino-LIME2

SY0605E-CHINA – cheaper power supply adapter 50Hz (EU) 5V/1A for A20-OLinuXino-LIME2

A20-LIME2-ANDROID-SD – a tested class 10 micro SD card with the latest (by the time of leaving the Olimex facilities) official Android release

A20-LIME2-DEBIAN-SD – a tested class 10 micro SD card with the latest (by the time of leaving Olimex facilities) official Debian Linux release

A20-OLinuXino-LIME2-UEXT – an adapter from 0.05" step connector to 0.1" step one; also suitable for LCD adapting

LCD-OLINUXINO-4.3TS – low-cost 4.3" LCD display with touchscreen component – 480×272

LCD-OLINUXINO-7TS – low-cost 7" LCD display with optional touchscreen component – 800×480

LCD-OLINUXINO-10TS – low-cost 10" LCD display with optional touchscreen component – 1024×600

LCD-OLINUXINO-15.6 – low-cost 15.6" LCD display – 1366×768

LCD-OLINUXINO-15.6FHD – low-cost Full HD 15.6" LCD display – 1920×1080

CABLE-IDC40-15cm – cable for LCD to LCD_CON connection

SATA-HDD-2.5-500GB – 500GB 2.5" SATA hard disk

SATA-CABLE-SET – cables that allow the connection of a 2.5" hard disk to the board

ALUMINIUM-HEATSINK-20×20×6MM – heatsink radiator for better processor heat dissipation

How to purchase?

You can purchase directly from our online shop at <https://www.olimex.com/>

You can purchase from any of our distributors. Sometimes it is faster and cheaper to purchase Olimex products from our distributors. List of confirmed Olimex LTD distributors and resellers: <https://www.olimex.com/Distributors>

8.4 Frequently asked questions

Q: I power my board, it shows a logo and then nothing happens.

A: This might be due to a number of reasons but it is recommended to try the following:

1. Download latest official image from our wiki (either Android or Debian for SD card), and upload it to an SD card again. There are instructions how to do it in the other questions below. Try if the board works now.
2. Check if your power supply provides enough current, try with different/better power supply.
3. Check the USB hub you are using, plug the USB cable directly to the back of your personal computer, check the USB cable.
4. The board might enter sleep mode very fast (especially if the Android was turned off without the "Quick Boot" mode being ticked on). Try pressing or holding down the PWR button for a couple of seconds to wake it up.

Q: What is the operating temperature range of A20-OLinuXino-LIME2?

A: The board works in the commercial temperature range 0+70C.

Q: How long this board will be available?

A: This board will be available [forever](#).

Q: I use LCD_CON for video output. There is some screen flickering under Debian. What could be the reason?

A: This is usually caused by either a loose cable connection or badly configured script.bin. Double check if all cables are properly connected. Also check if there is a change in the behavior if you either twist the cables carefully or press different components at the back.

If the above doesn't fix the flickering problem, edit the script bin parameter `lcd_io_cfg0` – make sure that it is set to `= 0x10000000 (1x1 and 7x0)`.

Q: How do I write the Linux image to a micro SD card to use with my A20 board?

A: To write a Linux image to an SD card under Windows we use Win32 Disk Imager:

Download Win32 Disk Imager software

Insert card

Start program

Select file

Click "write"

To write a Linux image to an SD card under Linux:

For instance you have an image with the file name of "debian_2g.img". It would be downloaded to the SD card connected to a Linux machine using one of the following commands:

```
# dd bs=4M oflag=sync if=debian_2g.img of=/dev/sdX
```

or

```
# cp debian_2g.img /dev/sdX
```

where X is the uSD card.

Q: How to detect and enable the Ethernet controller (if it is disabled by default)?

A: You can enable it by following these two steps:

1. To check under what name the LAN is associated write "ifconfig -a"
2. If, for example, it is under eth0 name, then write: "dhclient eth0"

This should enable the Ethernet and then SSH would also be available.

You can also enable auto detection of Ethernet on power-up by removing the comment `#auto eth0` in `/etc/network/interfaces` in the Linux image.

Q: How to install Android on an SD-card?

A: First download one of the official Android images, which might be found in the Android section above.

Make sure that the download link you visit clearly indicates that the image is suitable for the microSD card since there are images suitable for NAND memory also. The images suitable for the microSD memory and those suitable for NAND card are different. However, the upload method is almost identical – using PhoenixSuit.

There are two types of Android images for microSD card that we usually provide and each of them has to be downloaded to a microSD card using a different method. The image provided for microSD card is either the native Android image that can be downloaded to the card via a software tool like PhoenixSuit (through the board) or an image taken from an already prepared microSD card that requires to simply write the image (through a microSD card reader).

It is more likely that you have an Android image that requires a simple copy to a card. If that is the case you can follow the exact steps as for Linux (e.g. using "Win32 Disk Imager" or "dd" command).

In order to prepare a microSD card with a native Android you will need a software tool called PhoenixSuit and then:

- Install and run PhoenixSuit.
- Go to the firmware tab of the program and point to a valid Android image (note that the images on Gdrive are compressed and you have to extract the archives to .img files to be able write them with PhoenixSuit)
- Disconnect the power supply and USB cable from the A20 board. Put an SD card in micro SD holder. We recommend 4GB class 10 card.
- Press and hold RECOVERY button, apply power supply 5V, release RECOVERY button.
- Connect USB cable to the mini USB connector.
- You will be asked for drivers for the boot-loader. Navigate to the folder where you extracted the PhoenixSuit and install the drivers from the respective executables (or manually point the installer to

the drivers folder in the PhoenixSuit installation path).

- PhoenixSuit will detect the board and would ask for the method of writing the image. Choose method of writing the image and confirm your wish to write the image.
- Wait till upgrade succeeds

Note that it is not recommended to have your mini USB connected to an external USB hub. This might cause delays and might distort the signal levels. Always test with the USB connected straight to the USB ports of your computer.

Important: When Android runs for very first time it takes several minutes to initialize all files and buffers please do not cut the power supply during this process! Also when fresh image is installed fast boot may be disabled, which means that when you apply power supply after few seconds Android will go in sleep mode and you have to press PWR button to start it, you can change to fast boot when you power off there is dialog box asking you if you want next boot to be fast boot, you have to check this box before you power off. Also note that you must do touch screen calibration when you run Android for very first time which might require a mouse.

Q: How to edit board configurations and definitions in the official Debian Linux?

A: Do you want a custom video resolution output? Do you need a different port definition? Do you need to change the hardware definitions of the board?

It is explained above in the manual. But you can also visit this wiki article: [wiki article](#).

Q: How to edit board configurations and definitions in the official Android images?

A: There is a wiki article about that, please visit: [wiki article](#).

Q: Is it possible to boot Debian from NAND? Do you provide such image?

A: Yes, it is possible. Use the latest Debian Jessie image and write "nandinstall". If there are problems try to upload Android first to the NAND and then try "nandinstall" again. More information can be found in this wiki article: [installing Debian Jessie to the 4GB NAND memory](#).

There are other people who are also successful in booting Debian from the NAND. Make sure to check on the forum. Make sure to check the number of very good and optimized A20-OLinuXino Debian images by Igor Pečovnik. There are also his instructions for NAND installation of Debian: [link to his web-site](#).

Q: Is it possible to boot Debian from eMMC? Do you provide such image?

A: Yes, it is possible. Use the latest Debian Jessie image and type `"/emmc.sh"`. More information can be found in this wiki article: [installing Debian Jessie to the eMMC memory](#).

Q: How to generate boot-able SD-card Debian Linux image for A20-OLinuXino-LIME?

A: Build instructions and required files for the latest Debian images can be found in our GitHub repository.

Building Debian Wheezy images:

<https://github.com/OLIMEX/OLINUXINO/tree/master/SOFTWARE/A20/A20-build-3.4.90>

Building Debian Jessie images:

<https://github.com/OLIMEX/OLINUXINO/tree/master/SOFTWARE/A20/A20-build-3.4.103>

Note that Linux-Sunxi kernel is a work-in-progress, this means you can try the current stage/sunxi-x.x branch but if something is broken and doesn't work just revert to the git tags we give in the blog and they would work for sure.

Q: Can I use mainline kernel instead of Sunxi kernel?

A: You can. However, most kernels are headless – no audio or video output are supported. If you don't need audio or video – go for it – it had been tested and confirmed working (there are installation reports even) here: <https://wiki.debian.org/InstallingDebianOn/Allwinner>

Q: I have a 4GB version of the board. The board doesn't seem to have Android loaded.

A: We no longer load Android on the NAND memory of the boards. You can upload Android following the advice above in this document.

8.5 Product support

For product support, hardware information and error reports mail to: support@olimex.com. All document or hardware feedback is welcome. Note that we are primarily a hardware company and our software support is limited. Please consider reading the paragraph below about the warranty of Olimex products.

All goods are checked before they are sent out. In the unlikely event that goods are faulty, they must be returned, to OLIMEX at the address listed on your order invoice.

OLIMEX will not accept goods that have clearly been used more than the amount needed to evaluate their functionality.

If the goods are found to be in working condition, and the lack of functionality is a result of lack of knowledge on the customers part, no refund will be made, but the goods will be returned to the user at their expense.

All returns must be authorized by an RMA Number. Email support@olimex.com for authorization number before shipping back any merchandise. Please include your name, phone number and order number in your email request.

Returns for any unaffected development board, programmer, tools, and cables permitted within 7 days from the date of receipt of merchandise. After such time, all sales are considered final.

Returns of incorrect ordered items are allowed subject to a 10% restocking fee. What is unaffected? If you hooked it to power, you affected it. To be clear, this includes items that have been soldered to, or have had their firmware changed. Because of the nature of the products we deal with (prototyping electronic tools) we cannot allow returns of items that have been programmed, powered up, or otherwise changed post shipment from our warehouse.

All returned merchandise must be in its original mint and clean condition. Returns on damaged, scratched, programmed, burnt, or otherwise 'played with' merchandise will not be accepted.

All returns must include all the factory accessories which come with the item. This includes any In-Circuit-Serial-Programming cables, anti-static packing, boxes, etc.

With your return, enclose your PO#. Also include a brief letter of explanation of why the merchandise is being returned and state your request for either a refund or an exchange. Include the authorization number on this letter, and on the outside of the shipping box.

Please note: It is your responsibility to ensure that returned goods reach us. Please use a reliable form of shipping. If we do not receive your package we will not be held liable.

Shipping and handling charges are not refundable. We are not responsible for any shipping charges of merchandise being returned to us or returning working items to you.

The full text might be found at <https://www.olimex.com/wiki/GTC#Warranty> for future reference.

X-ON Electronics

Largest Supplier of Electrical and Electronic Components

Click to view similar products for [Single Board Computers](#) category:

Click to view products by [Olimex](#) manufacturer:

Other Similar products are found below :

[EMB-IB897-I45P](#) [5962-8872609LA](#) [BLKNUC7I3DNHNC1978015](#) [IOT-LS1012A-OXALIS](#) [NITX-300-ET-DVI](#) [UPN-EHLX4E-A10-0432](#)
[UP-APL03C2FLH-A10-0232](#) [NANO-EHL-J6412C-R10](#) [HYPER-EHL-J6412B-R10](#) [iDPM-LVDS-R10](#) [E38F540100](#) [SDM510L-I5H-3H1](#)
[HUMMINGBOARD-I2EX BASE + WIFI/BT](#) [HUMMINGBOARD-I4 PRO + WIFI/BT](#) [VAB-600-B](#) [RT5350F-OLINUXINO-EVB](#) [MITX-](#)
[440-DVI-2E](#) [NITX-315-DEVKIT](#) [A13-SOM-512](#) [AM3359-SOM-EVB-IND](#) [1996](#) [AIMB-223G2-S0A1E](#) [AIMB-562VG-GRA1E](#) [MIO-](#)
[5270DZ-2GS0A1E](#) [PCE-5126QVG-00A1E](#) [PCE-5125QG2-00A1E](#) [MIO-5251E-S3A1E](#) [MIO-2261Z-2GS6A1E](#) [SIMB-M22-2G2S0A1E](#)
[ASMB-823I-00A1E](#) [MIO-5251J-U0A1E](#) [AIMB-502WG2-00A1E](#) [BBB01-SC-505](#) [UPS-APLC2-A10-0432](#) [PICO300VGA-N3060](#)
[PICO300HGA-N3710](#) [W65C265QBX](#) [DFR0444](#) [DFR0419](#) [UPS-APLP4-A10-0864](#) [UPS-APLP4-A10-08128](#) [DFR0418](#) [DFR0546](#) [Nit6Q_i](#)
[M2M \(TELIT\)](#) [RELAY](#) [PROFESSIONAL](#) [A20-OLINUXINO-LIME-E16GS16M](#) [A20-OLINUXINO-LIME-S16M](#) [A20-OLINUXINO-](#)
[LIME2-E16GS16M](#)