

Delay OFF Rocker Switch A8GS-T

Minimum size class in the industry Remote Reset Rocker Switch with Delay OFF Function

- Rocker switch with Delay OFF Function. Switch is kept to turn ON, even if button is operated to turn OFF, and Switch is turned OFF by external signal.
- Zero standby power with Reset function, switching OFF by external signal.
- Preventing from application trouble such as a data lost or circuit damage by forced power OFF.
- Timing control of main power switch turn OFF for safety application design with Delay OFF function.
- Contact gap of 3 mm minimum.
- UL and cUL standard approved, Conforming to EN standards.



NEW

RoHS Compliant (Please refer the Precautions)

Usage example

Saving energy by cutting standby power.
 Saving energy by preventing forgetting turn OFF main power.
 Turning OFF main power by remote.
 Turning OFF main power of many equipments at the same time.
 Timing control of main power switch turn OFF for safety design.
 Preventing from circuit and data damage by power flicker.

* There are 2 kinds of main models A8GS. (Delay OFF Function model and Remote Reset model) With regard to the models with Delay OFF Function, please refer to the other catalog.

List of Models

Contact Form 1 to 4: Power contact terminal a, b: Signal contact terminal +, -: Coil terminal		Signal Contact Terminal: SPST + Power Contact Terminal: DPST		Quantity per box
		Signal Contact Terminal × 1 + Power Contact Terminal × 2		
Terminals		Signal Contact Terminal: CT Connector Power Contact Terminal: Quick-connect terminals #187(t=0.8)	Signal Contact Terminal: CT Connector Power Contact Terminal: Solder terminals	
Marking on caps	No Marking	A8GS-T1185K	A8GS-T1115K	50
		A8GS-T1285K	A8GS-T1215K	
		A8GS-T1385K	A8GS-T1315K	

Note: 1. This is not general 3 pole switch.
 (1) Signal contact terminal is only for detecting button ON/OFF.
 (2) Power contact terminal is for turning ON/OFF of circuit. Switch is turned OFF by external signal only, after turning OFF of button.

A8GS-T

Ratings

Contact Ratings

	Rated voltage	Rated current (Resistive load)
Power Contact Terminal	125 VAC	16 A
	250 VAC	10 A
Signal Contact Terminal	5 VDC	0.2 A

Note: 1. The above ratings were tested under the following conditions:

- (1) Ambient temperature : 20 ± 2 °C
- (2) Ambient humidity : 65 ± 5 % RH
- (3) Switching frequency : 7 times/min

Reset Coil Ratings

Rated voltage, current	Operating voltage range	Rated usage cycle	Coil resistance (Coil temperature: 20 ± 2 °C)
5 VDC 455 mA	4.5 to 5.5 VDC	ON: 50 to 100 ms OFF: Min 5 sec	$11 \Omega \pm 20$ %

Note: 1. Voltage for coil should be set within operating voltage range and applied time should be within rated usage cycle. Otherwise the performance of the coil may be deteriorated.

Note: 2. In case of applying voltage within the range from 5.5 to 24 VDC to the coil, contact your OMRON sales representative.

Contact specifications

	Signal contact	Power contact
Material	Gold alloy	Silver alloy
Contact gap	3 mm	3 mm
Minimum applicable load (Reference value) *	3 VDC 1 mA	5 VDC 200 mA

* Please refer to "Using Micro loads" in "Precautions" for more information on the minimum applicable load.

Characteristics

Permissible operating frequency	Mechanical	Switch operation: 20 times/min max, Coil operation: 7 times/min max
	Electrical	7 times/min max
Insulation resistance		100 M Ω min (at 500 VDC with insulation tester)
Contact resistance (initial value)	Power contact terminal	100 m Ω max (6 VDC to 8 V, 1 A Voltage drop method)
	Signal contact terminal	100 m Ω max (6 VDC to 8 V, 0.1 A Voltage drop method)
Dielectric strength	Between terminals of the same polarity	2,000 VAC 50/60 Hz 1 min
	Between terminals of the different polarity	2,000 VAC 50/60 Hz 1 min
	Between each terminals of the switch and terminals of coil	4,000 VAC 50/60 Hz 1 min
	Between each terminals of switch and ground	4,000 VAC 50/60 Hz 1 min
Vibration resistance *	Malfunction	10 to 55 Hz 1.5 mm double amplitude (Malfunction 1 ms max)
	Destruction	300 m/s ² min (Malfunction 1 ms max)
Shock resistance *	Malfunction	1000 m/s ² max
	Destruction	
Ambient operating temperature		-10 to +55 °C (with no icing or condensation, 60 % RH max)
Ambient operating humidity		90 % RH max (+5 to 35 °C with no icing or condensation)
Durability	Mechanical	Switch operation: 30,000 operations min, Coil operation: 10,000 operations min
	Electrical	Switch operation: 10,000 operations min, Coil operation: 10,000 operations min
Degree of protection		IEC IP40
Contact release time **		100 ms max
Weight		A8GS-TxxxxK: Around 15 g

Note: 1. Above specification values are initial values.

* For the testing condition in individual specification, contact your OMRON sales representative.

** Time from voltage applied to reset coil to actual contacts opening.

Approved Safety Standards

UL (UL61058-1)

	Approved safety standards ratings
Power contact terminal	16 A 125 VAC
Signal contact terminal	10 A 250 VAC
	–

TÜV (EN61058-1)

	Approved safety standards ratings
Power contact terminal	10(4) A 250 VAC
Signal contact terminal	0.2 A 5 VDC

Note: 1. There are no approved models of TV-8 rating for Delay OFF Function models.

Connector for Signal Switch Circuit and Coil Circuit

CT connectors produced by Tyco Electronics Corporation or XR connectors produced by JST shall be used for connection of Signal and Coil circuit. Other connectors shall not be used.

	Connector Terminal no.	Connection with Switch	Tyco Electronics Corporation: CT connector				JST: XR Connector	
			Pressure welding type		Cramping type			
			Housing	Contact				
			AWG #30-26	AWG #26-22	AWG #28-26	AWG #24	AWG #28-26	
Signal contact terminal	1	a (Switch COM)	179228-3	179609-1	179227-1	173977-3	2-179694-3	03XR-6□-P*
	2	---						
	3	b (Switch NO)						
Coil terminal	1	+ (Coil)	179228-2			173977-2	2-179694-2	02XR-6□-P*
	2	- (Coil)						

* □ indicates Housing color.

Operation

Delay OFF Function

Power contacts are kept in ON status, even if button is operated to turn OFF by manual operation of button.
And Switch is turned OFF by external signal to coil embedded in switch.

- (1) Signal contact terminal and Power contact terminal are turned ON by manual operation of button.
- (2) Power contact terminal is kept in ON status, even if button is operated to turn OFF by manual operation.
Only Signal contact terminal is turned OFF.
- (3) Power contact terminal is turned OFF when external signal is applied to coil.
Furthermore, it is able to turn OFF both signal and power contact terminals from manual ON condition at the same time by applying voltage to coil as Remote Reset Function.

Delay OFF Function Operation

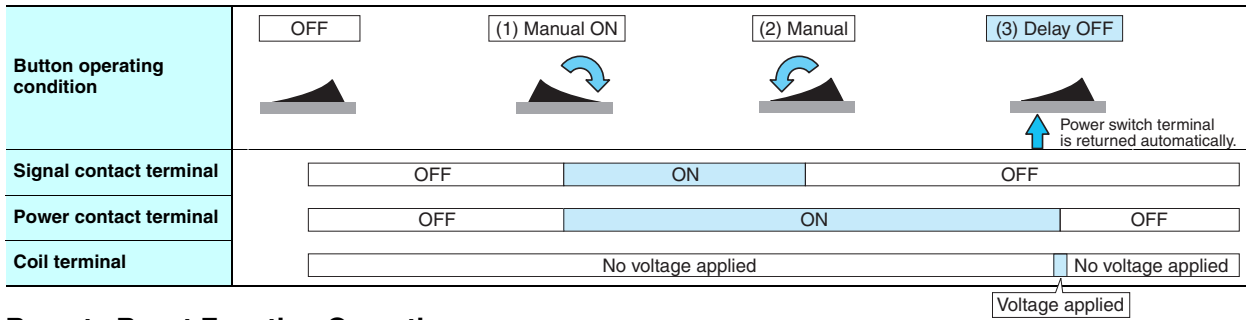

Remote Reset Function Operation

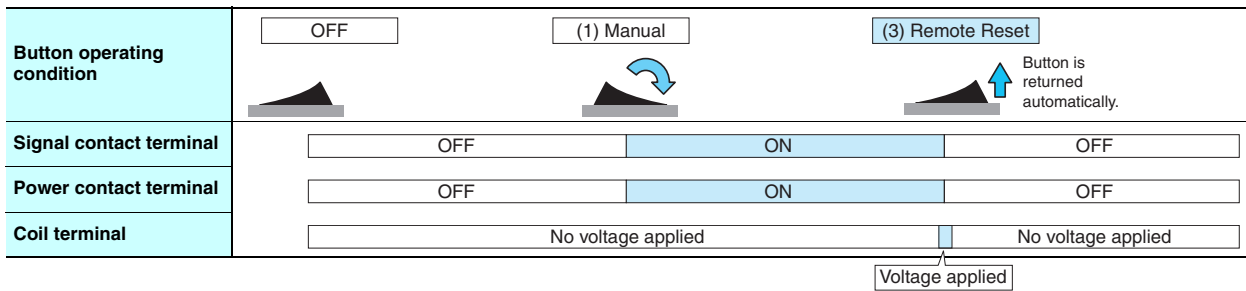

Note: 1. Once switch is turned ON, Power contact terminal is not able to be turned OFF by manual operation.
Please apply the voltage to the coil in order to turn OFF Power switch circuit.

Switch circuit and operating condition

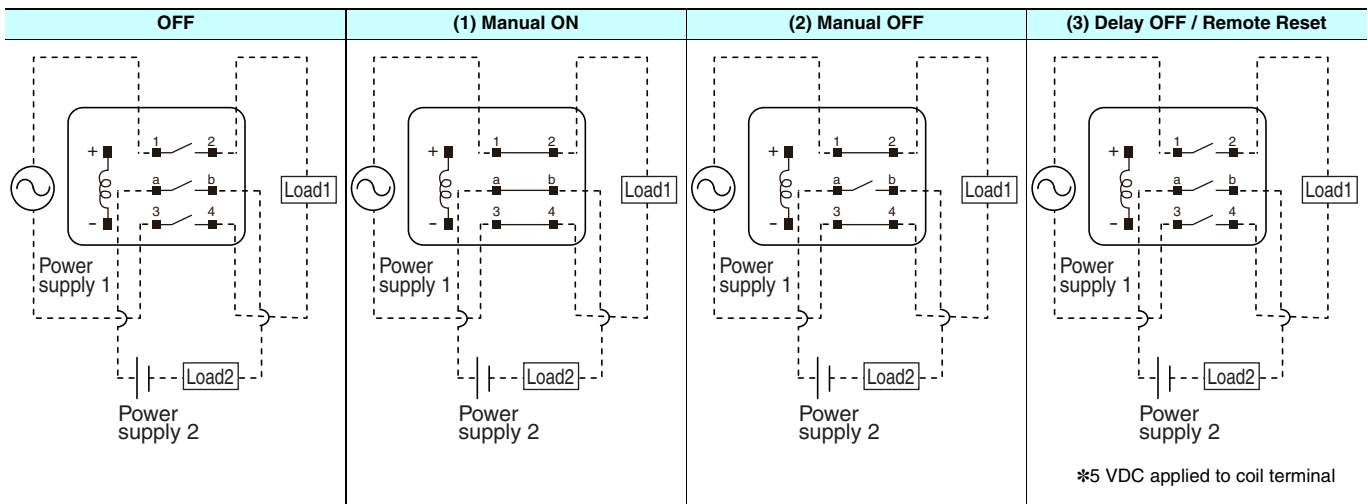

Dimensions (Unit: mm)/Operating Characteristics

A8GS-T1□85K

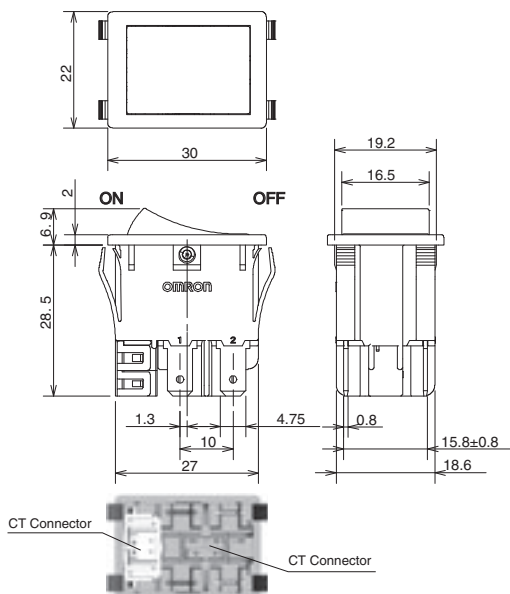

- Note:** 1. Unless otherwise specified, a tolerance of ± 0.4 mm applies to all dimensions.
Note: 2. At initial operation or operation after reset, operating force is increased, due to switch structure.
Note: 3. Solder terminals model has different hole shape, comparing with Quick-connect terminals. Outline and characteristics are same.
Note: 4. No models of switch without delay off function (without coil), due to product design.

Panel Cutout

Panel thickness: 0.8 to 2.3 mm

Panel cutout design is for prevention of false insertion.
 Please be careful about the direction of the protrusion.

The rollover of the panel shall be on the front face.
 And panel back side shall be Edge shape by processing.

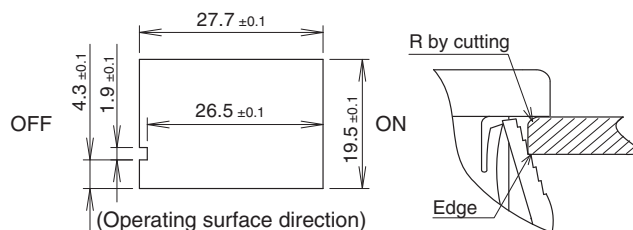

- Note:** 1. Recommendation panel material is "SPCC", however, in case of soft material or Panel back side shape is not edge, mounting strength may down. Please check and try by actual mounting panel and set the Panel thickness and hole dimension.

A8GS-T

Precautions

⚠ WARNING

Do not wire the switch or touch any terminal of the Switch while power is being supplied. Or it may result in electric shock.



Cautions

Use the switch within the rated voltage and current ranges, otherwise the switch may have deteriorated durability radiate heat, or burn out. This particularly applies to the instantaneous voltages and currents when switching.

Caution of usage

●Mounting

- Easy to mount by snap fitting.
- Do not impose excessive force on switch at the time of panel mounting.
- Do not detach the switch after installed. Otherwise, the holding strength may be loose.
- Apply the force to housing when installing to panel. Do not apply the force to the button (rocker) part when installing to the panel.

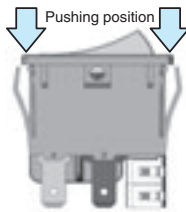

●Wiring

- Confirm the size of the receptacles and be sure to connect them firmly.
- Use an appropriate wire allowable to carry current.
- Be sure that there is no mechanical stress on terminals and coil terminals. Otherwise, the switch may malfunction and/or damaged. (Example: Too strong wiring)

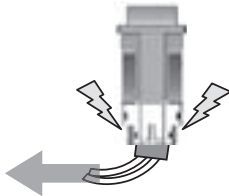

- Take appropriate insulation distance between switch terminal and other metal parts after wiring.
- Coil has polarity, please confirm polarity when wiring.
- Do not apply continuous voltage more than 10 seconds at any time. Otherwise, insulation deterioration may occur by heat of coil. Please consider the circuit design.
- Reverse voltage may cause of accurate discrete semiconductor devices. In case of controlling by accurate discrete semiconductor devices, Please consider the circuit design. (Example : add the surge absorbing circuit)
- In case of manual soldering, soldering time is max 4 sec by soldering iron (Max 350 °C at the iron tip) and do not add the stress to terminals.
- In case of touching the soldering iron to the root of terminals, it may cause Housing parts melt.

●Handling

- Do not apply excessive operating force to the switch.
- Do not drop or apply the excessive shock. Otherwise the switch may be damaged or deformed.
- Do not impose force to operating part from an angle, Otherwise the switch may be damaged or deformed.

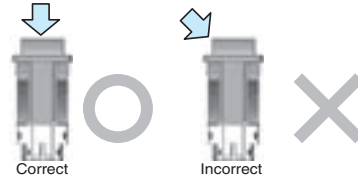

●Environment for storage and use

- To prevent the terminals color change and others while storage, Do not keep for a long term in the following conditions.
 - (1) High temperature, high humid environment
 - (2) Corrosive gas
 - (3) The place where the direct rays of the sun
 - (4) The place where the sea breeze
 - (5) Environmental with a sudden temperature changeThis switch is not sealed to prevent from entering dust and liquid. Do not use under dust and liquid condition.
- Switch shall not be icing or condensation.
- Strong magnetic field may cause malfunction. Check function is recommended under practical use conditions.

●Using Micro Loads

In case of using the switch under the micro loads, please refer the Minimum applicable load and set the load more than minimum applicable load.

Even when using micro load within the operating range, inrush current occurs, it may increase contact wear and so deteriorate durability. Therefore, insert a contact protection circuit where necessary.

The minimum applicable load is the L-level reference value. This value indicates the malfunction reference level for the reliability level of 60 %. ($\lambda 60$)

The equation, $\lambda 60 = 0.5 \times 10^{-6} / \text{operations}$ indicates that the estimated malfunction rate is less than 1/2,000,000 operations with a reliability level of 60 %.

●RoHS Compliant

The "RoHS Compliant" designation indicates that the listed models do not contain the six hazardous substances covered by the RoHS Directive.

Reference: The following standards are used to determine compliance for the six substances.

Lead	: 1,000 ppm max.
Mercury	: 1,000 ppm max.
Cadmium	: 100 ppm max.
Hexavalent chromium	: 1,000 ppm max.
PBB	: 1,000 ppm max.
PBDE	: 1,000 ppm max.

- Application examples provided in this document are for reference only. In actual applications, confirm equipment functions and safety before using the product.
- Consult your OMRON representative before using the product under conditions which are not described in the manual or applying the product to nuclear control systems, railroad systems, aviation systems, vehicles, combustion systems, medical equipment, amusement machines, safety equipment, and other systems or equipment that may have a serious influence on lives and property if used improperly. Make sure that the ratings and performance characteristics of the product provide a margin of safety for the system or equipment, and be sure to provide the system or equipment with double safety mechanisms.

Note: Do not use this document to operate the Unit.

X-ON Electronics

Largest Supplier of Electrical and Electronic Components

Click to view similar products for [Rocker Switches](#) category:

Click to view products by [Omron](#) manufacturer:

Other Similar products are found below :

[LTILA6E-1S-WH-RC-FN12VXCR1](#) [6-1571986-9](#) [8007K26N324V52](#) [8055K23Z7V](#) [8055K32Z7V](#) [8055K52Z7V](#) [8138K20E6M50](#) [84206L](#)
[84312LX](#) [PREDD5-07F-BB0GW](#) [999-16716-002](#) [999-16716-003](#) [999-16716-004](#) [A101J1V3Q004](#) [A101J2ZQ004](#) [A101J4ZQ004](#)
[A101J51CB0004](#) [A103J1ZQ004](#) [A201J1AQ004](#) [A201J3ZB004](#) [A201J50ZQ004](#) [A203J51ZQ0004](#) [A435S1YZQ](#) [H8500XBBBBL-A](#)
[H8653VBBG2577W](#) [HB130CHNWWNAAC](#) [R13112ABB-602W](#) [1251.0303](#) [AE205J60V3B004](#) [1352.0107](#) [1500G51E](#) [1571099-3](#)
[1571987-4](#) [1571987-5](#) [1571989-7](#) [1571988-5](#) [B123J77V7B2](#) [B226J50W4Q22P](#) [B433J37ZQ22M](#) [160212E](#) [1634200-7](#) [1801.1164](#) [1839.1502](#)
[PANEL-PLUG-VHP-BLACK](#) [PANEL-PLUG-VHP-WT](#) [K1ABBSCADN](#) [K2ABAAAAAA](#) [KG312A2DXD246X](#) [250011E714](#) [2600HM11E](#)